



2018 Multifamily Uniform Application

NOTICE: For Applicants planning to submit an Application on or before January 26, 2018, ANYTHING that would have been due on March 1, 2018 will be due on January 26, 2018. Anything due after March 1, 2018 maintains its original due date.



TEXAS DEPARTMENT OF HOUSING AND COMMUNITY AFFAIRS

221 E. 11th St., Austin, TX 78701 Main Number: 512-475-3800 Email: Info@tdhca.state.tx.us
P.O. Box 13941, Austin, TX 78711 Toll Free: 800-525-0657 Web: www.tdhca.state.tx.us

Equal Opportunity Employer/Program. Auxiliary aids and services are available upon request to individuals with disabilities.
Relay Texas: 800-735-2989 (TTY) and 711 (Voice).





TEXAS DEPARTMENT OF
HOUSING & COMMUNITY AFFAIRS
Building Homes. Strengthening Communities.

2018

Multifamily Direct Loan

**Arlinda Gardens
Supportive Housing**



**TEXAS DEPARTMENT OF
HOUSING & COMMUNITY AFFAIRS**
Building Homes. Strengthening Communities.

TAB 1

Application Certification



2018 Multifamily Uniform Application Certification
Mailing Address: P.O. Box 13941, Austin, TX 78711-3941
Physical Address: 221 East 11th Street, Austin, TX 78701

Development Name: Arlinda Gardens Supportive Housing

The undersigned hereby makes an Application to Texas Department of Housing and Community Affairs. The Applicant affirms that they have read and understand the Uniform Multifamily Rules (Title 10, Texas Administrative Code, Chapter 10) and Qualified Allocation Plan (Title 10, Texas Administrative Code, Chapter 11). Specifically, the undersigned understands the requirements under 10 TAC §10.101 of the Uniform Multifamily Rules, Site and Development Requirements and Restrictions, as well as Internal Revenue Code Section 42. By signing this document, Applicant is affirming that all statements and representations made in this certification and application, including all supporting materials, are true and correct under penalty of law, including Chapter 37 of the Texas Penal Code titled Perjury and Other Falsification and subject to criminal penalties as defined by the State of Texas. Applicant is also affirming understanding of §10.2(e) of the Uniform Multifamily Rules, relating to Public Information Requests, specifically that the filing of an Application with Department is deemed as consent to release any and all information contained therein.

The undersigned further certifies that he/she has the authority to execute this certification.

Arlinda Gardens, Ltd

Applicant Entity Name

By:

[Signature]

Signature of Authorized Representative

Rick Sims

Printed Name

Managing Partner

Title

2-28-18

Date

Sworn to and subscribed before me on the

by Rick Sims

(Personalized Seal)



28th day of

February, 2018

[Signature]

Notary Public Signature

SHANNON M. RUPERT

Louisiana

Notary Public, State of

Webster Parish

County of

at least

My Commission Expires:

2-28-18

Date

#049054



Required for Tax Exempt Bond Developments only

4% Multifamily Housing Tax Credit Program Board Meeting Selection Form

Mailing Address: P.O. Box 13941, Austin, TX 78711-3941

Physical Address: 221 East 11th Street, Austin, TX 78701

Development Name: _____

Based on the expiration date of the bonds as reflected in the Certificate of Reservation issued by the Texas Bond Review Board, the above referenced Development must be scheduled for one of the TDHCA Board meetings noted below for consideration of the issuance of a Determination Notice. Therefore, as required in §10.201(2)(B) of the Uniform Multifamily Rules, all remaining Parts of the Application, including the ESA, the Market Study, Property Condition Assessment and Appraisal, if applicable, must be submitted at least 75 days prior to the Board meeting. It is important to note that submission of the documents 75 days in advance does not ensure that your Application will be placed on the meeting agenda as requested and changes to an Application (e.g. submission of new financing terms sheets) subsequent to submission may delay completion of Department staff's review or underwriting of the Application and presentation to the Board. Moreover, staff may choose to delay presentation to the Board in instances in which an Applicant is not reasonably expected to close within sixty (60) days of the issuance of a Determination Notice or may recommend the award be conditioned upon closing within a reasonable timeframe after Board approval. Further, the Applicant is encouraged to review §10.201(2)(B), the 2018 4% HTC and Tax Exempt Bond Process Manual and 2018 Multifamily Programs Procedures Manual for any requirements that need to be met prior to submission of the remaining Parts of the Application.

I request to be on the Board agenda selected below and pursuant to §10.201(2)(B) of the Uniform Multifamily Rules I understand that I must provide the remaining parts of the Application by the applicable corresponding deadline:

Board Meeting Date:

- January 18, 2018
- February 22, 2018
- March 22, 2018
- April 26, 2018
- May 24, 2018
- June 28, 2018
- July 12, 2018
- July 26, 2018
- September 6, 2018
- October 11, 2018
- November 8, 2018
- December 6, 2018

75 Day Deadline:

- November 3, 2017
- December 8, 2017
- January 5, 2018
- February 9, 2018
- March 9, 2018
- April 13, 2018
- April 27, 2018
- May 11, 2018
- June 22, 2018
- July 27, 2018
- August 24, 2018
- September 21, 2018

An Inducement Resolution has been approved by the Bond Issuer and a copy has been provided behind Tab 8.



**TEXAS DEPARTMENT OF
HOUSING & COMMUNITY AFFAIRS**
Building Homes. Strengthening Communities.

TAB 2

**Certification
of
Development Owner**

Certification, Acknowledgement, and Consent of Development Owner- §10.204(1)

The *Certification, Acknowledgement, and Consent of Development Owner* is included behind this tab.

****The form should be executed, notarized, and included in the full application document.****

The form for the certification will be posted to the Department's website at <http://www.tdhca.state.tx.us/multifamily/apply-for-funds.htm>

Please indicate whether any of the following required disclosure on the *Certification, Acknowledgement, and Consent of Development Owner* (to be used for data capture for application processing):

§10.101(a)(2) - Undesirable Site Features

§10.101(a)(3) - Undesirable Neighborhood Characteristics

§10.202(1)(M) - Termination of Relationship in an Affordable Housing Transaction

§10.901(17) - Unused Credit or Penalty Fee

Note: If any disclosures are indicated regarding §10.101(a)(3), submit the *Undesirable Neighborhood Characteristics Report Packet (UNCR)* located on the Department's website

<http://www.tdhca.state.tx.us/multifamily/apply-for-funds.htm>

Development Owner Certification, Acknowledgement and Consent

All defined terms used in this certification and not specifically defined herein have the meanings ascribed to them in Chapter 2306 of the Tex. Gov't Code, §42 of the Internal Revenue Code, and §10.3 of the Uniform Multifamily Rules.

The undersigned, in each and all of the following capacities in which it may serve or exist -- Applicant, Development Owner, Developer, Guarantor of any obligation of the Applicant, and/or Principal of the Applicant and hereafter referred to as "Applicant" or "Development Owner," whether serving in one or more such capacities, is hereby submitting its Application to the Department for consideration of Department funding.

Applicant hereby represents, warrants, acknowledges and certifies to the Department and to the State of Texas that:

The Development will adhere to the Texas Property Code relating to security devices and other applicable requirements for residential tenancies, and will adhere to local building codes or, if no local building codes are in place, then to the most recent version of the International Building Code.

This Application and all materials submitted to the Department constitute records of the Department subject to Tex. Gov't Code, Chapter 552. This includes all Third Party reports, which will be posted in their entirety on the Department's website, as they constitute a part of the Application. The Application is in compliance with all requirements related to the eligibility of an Applicant, Application and Development as further defined in 10 TAC §§10.101 and 10.202 of the Uniform Multifamily Rules. Any issues of non-compliance have been disclosed.

All representations, undertakings and commitments made by Applicant in the Application process for Development assistance expressly constitute conditions to any Commitment, Determination Notice, Carryover Allocation, or Direct Loan Commitment for such Development which the Department may issue or award, and the violation of any such condition shall be sufficient cause for the cancellation and rescission of such Commitment, Determination Notice, Carryover Allocation, or Direct Loan Award Letter, Commitment or Contract by the Department. To the extent allowed under Tex. Gov't Code §2306.6720, if any such representations, undertakings and commitments concern or relate to the ongoing features or operation of the Development, they shall each and all be enforceable even if not reflected in the Land Use Restriction Agreement. All such representations, undertakings and commitments are also

enforceable by the Department and the tenants of the Development, including enforcement by administrative penalties for failure to perform, in accordance with the Land Use Restriction Agreement.

When providing a Pre-Application, Application or other materials to a state representative, local governmental body, Neighborhood Organization, or anyone else to secure support or approval that may affect the Applicant's competitive posture, an Applicant must disclose that in accordance with the Department's rules the aspects of the Development may not have been determined or selected or may be subject to change, such as changes in the amenities ultimately selected and provided.

The Development Owner is and will remain in compliance with state and federal laws, including but not limited to, fair housing laws, including Chapter 301, Property Code, Title VIII of the Civil Rights Act of 1968 (42 U.S.C. §§3601 et seq.), the Fair Housing Amendments Act of 1988 (42 U.S.C. §§3601 et seq.), the Civil Rights Act of 1964 (42 U.S.C. §2000a et seq.), the Americans with Disabilities Act of 1990 (42 U.S.C. §§12101 et seq.), the Rehabilitation Act of 1973 (29 U.S.C. §§701 et seq.), Fair Housing Accessibility, the Texas Fair Housing Act; and the Development is designed consistent with the Fair Housing Act Design Manual produced by HUD, and the Texas Accessibility Standards. (§2306.257; §2306.6705(7))

The Development Owner has read and understands the Department's fair housing educational materials posted on the Department's website as of the beginning of the Application Acceptance Period.

All Applications proposing Rehabilitation (including Reconstruction) will be treated as substantial alteration, in accordance with 10 TAC Chapter 1, Subchapter B.

The Development Owner will establish a reserve account consistent with Tex. Gov't Code §2306.186, and as further described in §10.404 of the Uniform Multifamily Rules, relating to Replacement Reserve Account requirements.

The Development will operate in accordance with the applicable compliance monitoring requirements found in Chapter 10, Subchapter F.

The Development Owner agrees to implement a plan to use Historically Underutilized Businesses (HUB) in the development process consistent with the Historically Underutilized Business Guidelines for contracting with the State of Texas. The Development Owner will be required to submit a report of the success of the plan as part of the cost certification documentation, in order to receive IRS Forms 8609 or, if the Development does not have Housing Tax Credits, release of retainage.

The Applicant will attempt to ensure that at least 30% of the construction and management businesses with which the Applicant contracts in connection with the Development are Minority Owned Businesses as further described in Tex. Gov't Code §2306.6734.

The Development Owner will specifically market to veterans through direct marketing or contracts with veteran's organizations. The Development Owner will be required to identify how they will specifically market to veterans and report to the Department in the annual housing report on the results of the marketing efforts to veterans. Exceptions to this requirement must be approved by the Department.

Accessibility Requirements

The Development Owner understands that in accordance with Section 504 of the Rehabilitation Act of 1973 and implemented at 24 C.F.R. Part 8, if the Development includes the New Construction or substantial rehabilitation of multifamily units (4 or more units per building), at least five percent (5%) of all dwelling units will be designed and built to be accessible for persons with mobility impairments. A unit that is on an accessible route and is adaptable and otherwise compliant with the 2010 ADA Standards with the exceptions listed in "Nondiscrimination on the Basis of Disability in Federally Assisted Programs and Activities" (Federal Register 79 FR 29671) meets this requirement. In addition, at least two percent (2%) of all dwelling units will be designed and built to be accessible for persons with hearing or vision impairments.

The Development Owner understands that regardless of building type, all Units accessed by the ground floor or by elevator ("affected units") must meet the requirements at 10 TAC §10.101(b)(8)(B)..

The Development Owner certifies that all accessible Units under 10 TAC Chapter 1, Subchapter B, will be dispersed throughout the Development.

The Development Owner certifies that representations made in the Architect Certification are true and correct, and understands that the Department evaluation of architectural drawings may not include an assessment of accessibility. The Development Owner is responsible for any modifications necessary to meet accessibility requirements identified at the final construction inspection.

Unused Credit or Penalty Fee *(select one box as applicable)*

The Applicant returned a full credit allocation after the Carryover Allocation deadline required for that allocation and is subject to the Unused Credit or Penalty Fee pursuant to §10.901(17) of the Uniform Multifamily Rules.

The Applicant certifies that no disclosure regarding §10.901(17) of the Uniform Multifamily Rules is necessary.

Termination of Relationship in an Affordable Housing Transaction *(select one box as applicable)*

The Applicant has disclosed, in the Application, any Principal or any entity or Person in the Development ownership structure who was or is involved as a Principal in any other affordable housing transaction that has terminated, voluntarily or involuntarily, within the past 10 years or plans to or is negotiating to terminate their relationship with any other affordable housing development. The disclosure identified the person or persons and development involved, the identity of each other development and contact information for the other Principals of each such development, a narrative description of the facts and circumstances of the termination or proposed termination, and any appropriate supporting documents. The Applicant has read and understands §10.202(1)(M) of the Uniform Multifamily Rules related to such disclosure.

The Applicant certifies that no disclosure regarding §10.202(1)(M) of the Uniform Multifamily Rules is necessary.

The Applicant certifies that, for any Development proposing New Construction or Reconstruction and located within the one-hundred (100) year floodplain as identified by the Federal Emergency Management Agency (FEMA) Flood Insurance Rate Maps, the Development Site will be developed in full compliance with the National Flood Protection Act and all applicable federal and state statutory and regulatory requirements so that all finished ground floor elevations are at least one foot above the floodplain and parking and drive areas are no lower than six inches below the floodplain, subject to more stringent local requirements. The Applicant certifies that, floodplain maps will be used and the Development Site will comply with regulations as they exist at the time of commencement of construction. Applicant further certifies that, for any Development proposing Rehabilitation (excluding Reconstruction) that is not a HUD or TRDO-USDA assisted property, the Development Site is not located in the one-hundred year floodplain unless the existing structures already meet the requirements for New Construction or Reconstruction, as certified to by a Third Party engineer, or unless the state or

local government has undertaken and can substantiate sufficient mitigation efforts and such documentation is submitted in the Application.

Undesirable Site Features *(select one of the boxes as applicable)*

X The Development **is not** located in an area with undesirable site features as further described in §10.101(a)(2) of the Uniform Multifamily Rules.

The proposed Development is Rehabilitation (excluding Reconstruction) with ongoing and existing federal assistance from HUD, USDA, or Veterans Affairs (“VA”) and an exemption was requested prior to the filing of an Application or is being requested with the Application in accordance with §10.101(a)(2) of the Uniform Multifamily Rules.

The proposed Development is Historic Preservation pursuant to §11.9(e)(6) of the QAP, is located in an area with an undesirable site feature and an exemption was requested prior to the filing of an Application or is being requested with the Application.

The proposed Development is New Construction, is located in an area with an undesirable site feature and a copy of the local ordinance that regulates the proximity of such feature to a multifamily development is included in the Application.

The proposed Development **is** located in an area with an undesirable site feature and mitigation to be considered by staff and the Board is included in the Application.

Undesirable Neighborhood Characteristics *(select one of the main boxes as applicable)*

X The Development Owner certifies that the Development **is not** located in an area with any of the undesirable neighborhood characteristics described in §10.101(a)(3) of the Uniform Multifamily Rules and that no disclosure is necessary;

The Development Owner certifies that the Development **is** located in an area with the following undesirable neighborhood characteristic(s) and the Undesirable Neighborhood Characteristics Report is submitted with the Application (select all that apply):

in a census tract with a poverty rate above 40% for individuals (or 55% for Developments in regions 11 and 13);

in a census tract or within 1,000 feet of any census tract in an Urban Area and the rate of Part I violent crimes is greater than 18 per 1,000 persons (annually) as reported on neighborhoodscout.com;

_____ is located within 1,000 feet of a blighted or abandoned area as further described in §10.101(a)(3)(B)(iii) of the Uniform Multifamily Rules;

_____ is located in the attendance zones of an elementary, middle, or high school that does not have a 2017 Met Standard rating by the Texas Education Agency, unless the Development Site is subject to an Elderly Limitation.

The Development will include all of the mandatory Development amenities required in §10.101(b)(4) of the Uniform Multifamily Rules at no charge to all tenants (market rate and low-income) and written notice of such amenities will be provided to the tenants.

The Development will satisfy the minimum point threshold for common amenities as further described in §10.101(b)(5) of the Uniform Multifamily Rules. These amenities must be for the benefit of all tenants (market rate and low-income), meet accessibility standards, be sized appropriately to serve the proposed Target Population, be made available throughout normal business hours, and be maintained throughout the Affordability Period. The tenant must be provided written notice of the amenity elections made by the Development Owner.

The Development will meet the minimum size of Units as further described §10.101(b)(6)(A) of the Uniform Multifamily Rules.

The Development (excluding competitive Housing Tax Credit Applications) will include enough unit and development construction features to meet the minimum number of points as further described in §10.101(b)(6)(B) of the Uniform Multifamily Rules.

The Development (excluding competitive Housing Tax Credit Applications) will include enough tenant services, at no charge to the tenants, be accessible to all (market rate and low-income), and maintained throughout the Affordability Period, to meet the required minimum number of points as further described in §10.101(b)(7) of the Uniform Multifamily Rules, and offered in accordance with §10.619 of the Uniform Multifamily Rules. The tenant must be provided written notice of the elections made by the Development Owner.

If the Applicant is applying for Multifamily Direct Loan funds and the Development consists of New Construction, the Applicant further certifies that the Development meets the Construction Site Standards in 24 C.F.R §983.57(e).

If the Development has an existing LURA with the Department, the Development Owner will comply with the existing restrictions.

The Development Owner will comply with any and all notices required by the Department.

None of the criteria in subparagraphs (A) – (M) of §10.202(1) of the Uniform Multifamily Rules, related to ineligible Applicants, applies to those identified on the organizational chart for the Applicant, Developer and Guarantor.

The individual whose name is subscribed hereto, in his or her individual capacity, on behalf of Applicant, and in all other related capacities described above, as applicable, expressly represents, warrants, and certifies that all information contained in this certification and in the Application, including any and all supplements, additions, clarifications, or other materials or information submitted to the Department in connection therewith as required or deemed necessary by the materials governing the multifamily funding programs are true and correct and the Applicant has undergone sufficient investigation to affirm the validity of the statements made. Further, the Applicant hereby expressly represents, warrants, acknowledges and certifies that the individual whose name is subscribed hereto has read and understands all the information contained in this form of the Application.

By signing this document, the undersigned, in their individual capacity, on behalf of Applicant, whether formed or to be formed, and in all other related capacities described above, is affirming under penalty of Chapter 37 of the Texas Penal Code titled Perjury and Other Falsification, and subject to criminal penalties as defined by Tex. Penal Code §§37.01 et seq., and subject to any and all other state or federal laws regarding the making of false statements to governmental bodies or the providing of false information in connection with the procurement of allocations or awards, that the Application and all materials relating thereto constitute government documents and that the Application and all materials relating thereto are true, correct, and complete in all material respects.

2017 Multifamily Direct Loan Certification

By: _____

[Handwritten Signature]
Signature of Authorized Representative

Rick Sims

Printed Name

Executive Director

Title

2/22/2017
Date

THE STATE OF TEXAS §
COUNTY OF Dallas §

I, the undersigned, a Notary Public in and for said County and State, do hereby certify that name is signed to the foregoing statement, and who is known to be one in the same, has acknowledged before me on this date, that being informed of the contents of this statement, executed the same voluntarily on the date same foregoing statement bears.

GIVEN UNDER MY HAND AND SEAL OF OFFICE this 22 day of February 17

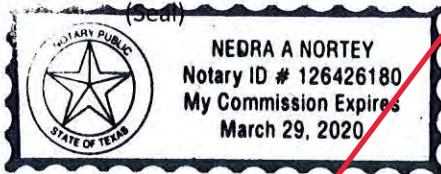

Nedra Northey
Notary Public Signature

2018 Development Owner Certification, Acknowledgement and Consent

By:



Signature

Rick Sims

Printed Name

Executive Director

Title

8-31-2018

Date

THE STATE OF Louisiana §
Parish §
COUNTY OF Ouachita §

Before me, a notary public, on this day personally appeared Rick Sims, known to me to be the person whose name is subscribed to the foregoing document and, being by me first duly sworn, declared and certified that the statements therein contained are true and correct.

GIVEN UNDER MY HAND AND SEAL OF OFFICE this 30th day of August, 2018

(Seal)

Notary Public Signature

ROBBY D. WILLIAMS
#51566



**TEXAS DEPARTMENT OF
HOUSING & COMMUNITY AFFAIRS**
Building Homes. Strengthening Communities.

TAB 3

Certification of Applicant Eligibility

Applicant Eligibility Certification-§10.204(2)

The *Applicant Eligibility Certification(s)* is included behind this tab.

§10.202 of the Uniform Multifamily Rules identifies situations in which an Application or Applicant may be ineligible for Department funding. Applicants must provide disclosure of all potential instances of ineligibility, along with evidence of appropriate corrective action taken and accepted by the Department or mitigating factors to be considered. Documentation should be attached behind this tab.

n/a Disclosure of all potential instances of ineligibility, along with evidence of appropriate corrective action is included behind this tab.

Applicant Eligibility Certification

All defined terms used in this certification and not specifically defined herein have the meanings ascribed to them in Chapter 2306 of the Tex. Gov't Code, §42 of the Internal Revenue Code, and §10.3 of the Uniform Multifamily Rules.

The undersigned, in each and all of the following capacities in which it may serve or exist or be contemplated to bring a new entity into existence-- Applicant, Development Owner, Developer, Guarantor of any obligation of the Applicant, and/or Principal of the Applicant and hereafter referred to as "Applicant," whether serving in one or more such capacities, is hereby submitting its Application to the Department for consideration of multifamily funding.

Applicant hereby represents, warrants, agrees, acknowledges and certifies to the Department and to the State of Texas that:

It has obtained all necessary consents and approvals, and conducted all necessary diligence to enable it to make these certifications and to perform any all agreements and to give all consents provided for or made herein.

All representations, undertakings and commitments made by Applicant in the Application process for a Development, whether with respect to Threshold Criteria, selection criteria or otherwise, expressly constitute conditions to any Commitment, Determination Notice, Carryover Allocation, or Direct Loan Commitment for such Development which the Department may issue or award, and the violation of any such condition shall be sufficient cause for the cancellation and rescission of such Commitment, Determination Notice, Carryover Allocation, or Direct Loan Commitment by the Department. To the extent allowed under §2306.6720 Tex. Gov't Code, if any such representations, undertakings and commitments concern or relate to the ongoing features or operation of the Development, they shall each and all shall be enforceable even if not reflected in the Land Use Restriction Agreement. All such representations, undertakings and commitments are also enforceable by the Department and/or the tenants of the Development, including but not limited to enforcement by assessment of administrative penalties for failure to perform, in accordance with the Land Use Restriction Agreement, the entry of orders by the Department's Governing Board requiring strict performance, or the obtaining of injunctive relief.

Neither Applicant nor any other member of the Development Team has been or is barred, suspended, or terminated from procurement in a state or Federal program or listed in HUD's System for Award Management (SAM).

Neither Applicant nor any other member of the Development Team has been convicted of a

2018 Applicant Eligibility Certification

state or federal felony crime involving fraud, bribery, theft, misrepresentation of material fact, misappropriation of funds, or other similar criminal offenses within fifteen (15) years preceding the Application submission.

Neither Applicant nor any other member of the Development Team is, at the time of Application, subject to an enforcement or disciplinary action under state or federal securities law or by the NASD; is subject to a federal tax lien; and/or is the subject of a proceeding in which a Governmental Entity has issued an order to impose penalties, suspend funding, or take adverse action based on an allegation of financial misconduct or uncured violation of material laws, rules, or other legal requirements governing activities considered relevant by the Governmental Entity.

Neither Applicant nor any other member of the Development Team has breached a contract with a public agency and failed to cure that breach within the timeframe provided or allowed by contract. If such breach is permitted to be cured under the contract, notice of the breach has been given and a reasonable opportunity to cure.

Neither Applicant nor any other member of the Development Team has misrepresented to a subcontractor the extent to which the Developer has benefited from contracts or financial assistance that has been awarded by a public agency, including the scope of the Developer's participation in contracts with the agency and the amount of financial assistance awarded to the Developer by the agency.

Neither Applicant nor any other member of the Development Team has been found by the Board to be ineligible based on a previous participation review performed in accordance with 10 TAC Chapter 1 Subchapter C.

Neither Applicant nor any other member of the Development Team is delinquent in any loan, fee, or escrow payments to the Department in accordance with the terms of the loan, as amended, or is otherwise in default with any provisions of such loans.

Neither Applicant nor any other member of the Development Team has failed to cure any past due fees owed to the Department within the time frame provided by notice from the Department and at least ten (10) days prior to the Board meeting at which the decision for an award is to be made.

Neither Applicant nor any other member of the Development Team is in violation of a state revolving door or other standard of conduct or conflict of interest statute, including §2306.6733 of the Tex. Gov't Code, or a provision of Chapter 572 of the Tex. Gov't Code, that would prohibit the Person from participating in the Application in the manner and capacity they are participating.

2018 Applicant Eligibility Certification

Neither Applicant nor any other member of the Development Team has previous Contracts or Commitments that have been partially or fully de-obligated during the twelve (12) months prior to the submission of the Application and through the date of final allocation due to a failure to meet contractual obligations, and the Person is not on notice that such de-obligation results in ineligibility under 10 TAC Chapter 10.

Neither Applicant nor any other member of the Development Team has provided false or misleading documentation or made other intentional or negligent material misrepresentations or omissions in or in connection with an Application (and certifications contained therein), Commitment, or Determination Notice for a Development..

Neither Applicant nor any other member of the Development team has been the owner or Affiliate of the owner of a Department assisted rental development for which the federal affordability requirements were prematurely terminated and the affordability requirements have not re-affirmed or Department funds repaid. .

Neither Applicant nor any other member of the Development Team has participated in the dissemination of misinformation about affordable housing and the persons it serves or about a competing Applicant that would likely have the effect of fomenting opposition to an Application where such opposition is not based on substantive and legitimate concerns that do not implicate potential violations of fair housing laws.

The Applicant will not violate §2306.1113 of the Tex. Gov't Code relating to Ex Parte Communication and further explained in §10.202(2)(A) of the Uniform Multifamily Rules.

For any Development utilizing Housing Tax Credit or Tax-Exempt Bonds, at all times during the two-year period preceding the date the Application Round begins (or for Tax-Exempt Bond Developments any time during the two-year period preceding the date the Application is submitted to the Department), the Applicant or a Related Party is not or has not been a member of the Board or employed by the Department as the Executive Director, Chief of Staff, General Counsel, a Deputy Executive Director, the Director of Multifamily Finance, the Chief of Compliance, the Director of Real Estate Analysis, a manager over the program for which an Application has been submitted, or any person exercising such responsibilities regardless of job title; or in violation of §2306.6733 of the Tex. Gov't Code.

For any Development utilizing Housing Tax Credits, the Applicant will not propose to replace in less than fifteen (15) years any private activity bond financing of the Development described by the Application, unless the exceptions in §2306.6703(a)(2) of the Tex. Gov't Code are met.

All the instances in which any Principal or any entity or Person in the Development ownership structure who was or is involved as a Principal in any other affordable housing transaction, that

2018 Applicant Eligibility Certification

has terminated voluntarily or involuntarily within the past ten years or is negotiating to terminate their relationship with any other affordable housing development have been fully disclosed pursuant to §10.202(1)(M) of the Uniform Multifamily Rules. Applicant understands that failure to disclose is grounds for termination.

All housing developments with which Applicant, Development Owner, Developer, Guarantor and/or Principal thereof participating, are in compliance with: state and federal fair housing laws, including Chapter 301, Property Code, the Texas Fair Housing Act; Title VIII of the Civil Rights Act of 1968 (42 U.S.C. Section 3601 et seq.); and the Fair Housing Amendments Act of 1988 (42 U.S.C. Section 3601 et seq.); the Civil Rights Act of 1964 (42 U.S.C. Section 2000a et seq.); the Americans with Disabilities Act of 1990 (42 U.S.C. Section 12101 et seq.); and the Rehabilitation Act of 1973 (29 U.S.C. Section 701 et seq.).

The making of an allocation or award by the Department does not constitute a finding or determination that the Development is deemed qualified to receive such allocation or award. Applicant agrees that the Department or any of its directors, officers, employees, and agents will not be held responsible or liable for any representations made to the undersigned or its investors relating to the Housing Tax Credit Program; therefore, Applicant assumes the risk of all damages, losses, costs, and expenses related thereto and agrees to indemnify and hold harmless the Department and any of its officers, employees, and agents against any and all claims, suits, losses, damages, costs, and expenses of any kind and of any nature that the Department may hereinafter suffer, incur, or pay arising out of its decisions and actions concerning this Application for Housing Tax Credits or the use of information concerning the Housing Tax Credit Program.

Applicant, Development Owner, Developer, Guarantor or other Related Party is not subject to any pending criminal proceedings and if any such proceeding or any other charges which would invalidate the certifications are finally adjudicated or otherwise disposed of prior to Carryover, the Applicant will immediately notify the Department. Such notification must be presented to the Board for consideration at the next available Board meeting.

The individual whose name is subscribed hereto, in his or her individual capacity, on behalf of Applicant, and in all other related capacities described above, as applicable, expressly represents, warrants, and certifies that all information contained in this certification and in the Application, including any and all supplements, additions, clarifications, or other materials or information submitted to the Department in connection therewith as required or deemed necessary by the materials governing the multifamily funding programs are true and correct and the Applicant has undergone sufficient investigation to affirm the validity of the statements made. The Applicant agrees that the Department may, at its discretion, request additional information and/or documentation in its evaluation of this Application and is authorized but

2018 Applicant Eligibility Certification

not obligated under this document to conduct its own investigation regarding any information required requested and or provided in relation to the Application or the Development. Further, the Applicant hereby expressly represents, warrants, and certifies that the individual whose name is subscribed hereto has read and understands all the information contained in this form of the Application.

By signing this document, the undersigned, in their individual capacity, on behalf of Applicant, whether formed or to be formed, and in all other related capacities described above, is affirming under penalty of Chapter 37 of the Texas Penal Code titled Perjury and Other Falsification and subject to criminal penalties as defined by the State of Texas. TEX. PENAL CODE ANN. §§37.01 et seq. (Vernon 2011) and subject to any and all other state or federal laws regarding the making of false statements to governmental bodies or the false statements or the providing of false information in connection with the procurement of allocations or awards that the Application and all materials relating thereto constitute government documents and that the Application and all materials relating thereto are true, correct, and complete in all material respects.

Falsification and subject to criminal penalties as defined by the State of Texas. TEX. PENAL CODE ANN. §§37.01 et seq. (Vernon 2011) and subject to any and all other state or federal laws regarding the making of false statements to governmental bodies or the false statements or the providing of false information in connection with the procurement of allocations or awards that the Application and all materials relating thereto constitute government documents and that the Application and all materials relating thereto are true, correct, and complete in all material respects.

By: [Signature]
Signature of Authorized Representative
Rick Sims
Printed Name
Executive Director
Title
2.28.17
Date

THE STATE OF Texas §
COUNTY OF Dallas §

I, the undersigned, a Notary Public in and for said County and State, do hereby certify that name is signed to the foregoing statement, and who is known to be one in the same, has acknowledged before me on this date, that being informed of the contents of this statement, executed the same voluntarily on the date same foregoing statement bears.

GIVEN UNDER MY HAND AND SEAL OF OFFICE this 28th day of February, 17

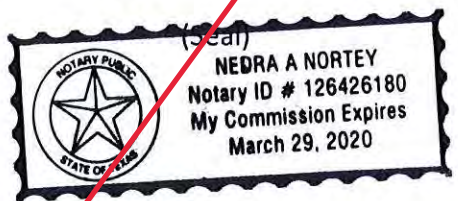

Nedra Northey
Notary Public Signature

2017 Applicant Eligibility Certification

Falsification and subject to criminal penalties as defined by the State of Texas. TEX. PENAL CODE ANN. §§37.01 et seq. (Vernon 2011) and subject to any and all other state or federal laws regarding the making of false statements to governmental bodies or the false statements or the providing of false information in connection with the procurement of allocations or awards that the Application and all materials relating thereto constitute government documents and that the Application and all materials relating thereto are true, correct, and complete in all material respects.

By: *Tomi Johnson*
Signature of Authorized Representative

Tomi Johnson

Printed Name

Secretary Vice-President

Title

2-26-17

Date

THE STATE OF Texas §
COUNTY OF Dallas §

I, the undersigned, a Notary Public in and for said County and State, do hereby certify that name is signed to the foregoing statement, and who is known to be one in the same, has acknowledged before me on this date, that being informed of the contents of this statement, executed the same voluntarily on the date same foregoing statement bears.

GIVEN UNDER MY HAND AND SEAL OF OFFICE this 26th day of February, 2017

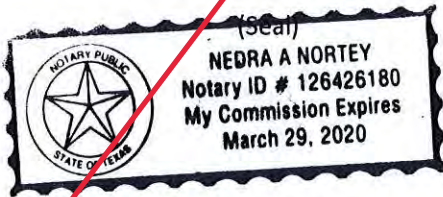

Nedra A. Northey
Notary Public Signature

2017 Applicant Eligibility Certification

Falsification and subject to criminal penalties as defined by the State of Texas. TEX. PENAL CODE ANN §§37.01 et seq. (Vernon 2011) and subject to any and all other state or federal laws regarding the making of false statements to governmental bodies or the false statements or the providing of false information in connection with the procurement of allocations or awards that the Application and all materials relating thereto constitute government documents and that the Application and all materials relating thereto are true, correct, and complete in all material respects.

By: *[Signature]*
Signature of Authorized Representative

Alethea Smith
Printed Name
Member
Title
02/26/2017
Date

THE STATE OF Texas §
COUNTY OF Dallas §

I, the undersigned, a Notary Public in and for said County and State, do hereby certify that name is signed to the foregoing statement, and who is known to be one in the same, has acknowledged before me on this date, that being informed of the contents of this statement, executed the same voluntarily on the date same foregoing statement bears.

GIVEN UNDER MY HAND AND SEAL OF OFFICE this 26th day of February, 2017
(Seal)

[Signature]
Notary Public Signature

2017 Applicant Eligibility Certification

Falsification and subject to criminal penalties as defined by the State of Texas. TEX. PENAL CODE ANN. §§37.01 et seq. (Vernon 2011) and subject to any and all other state or federal laws regarding the making of false statements to governmental bodies or the false statements or the providing of false information in connection with the procurement of allocations or awards that the Application and all materials relating thereto constitute government documents and that the Application and all materials relating thereto are true, correct, and complete in all material respects.

By: 
Signature of Authorized Representative

Lisa Mitchell
Printed Name
Director
Title
2-26-17
Date

THE STATE OF Texas §
COUNTY OF Dallas §

I, the undersigned, a Notary Public in and for said County and State, do hereby certify that name is signed to the foregoing statement, and who is known to be one in the same, has acknowledged before me on this date, that being informed of the contents of this statement, executed the same voluntarily on the date same foregoing statement bears.

GIVEN UNDER MY HAND AND SEAL OF OFFICE this 26th day of February, 2017

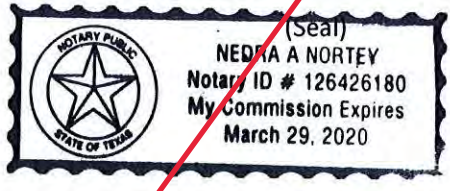

Nedra A. Northey
Notary Public Signature

2018 Applicant Eligibility Certification

By: [Signature]

Signature of Authorized Representative

Toni Smith

Printed Name

Treasurer

Title

5/17/18

Date

THE STATE OF Texas §

COUNTY OF Williamson §

Before me, a notary public, on this day personally appeared Toni Smith, known to me to be the person whose name is subscribed to the foregoing document and, being by me first duly sworn, declared and certified that the statements therein contained are true and correct.

GIVEN UNDER MY HAND AND SEAL OF OFFICE this 17th day of May, 2018

(Seal)

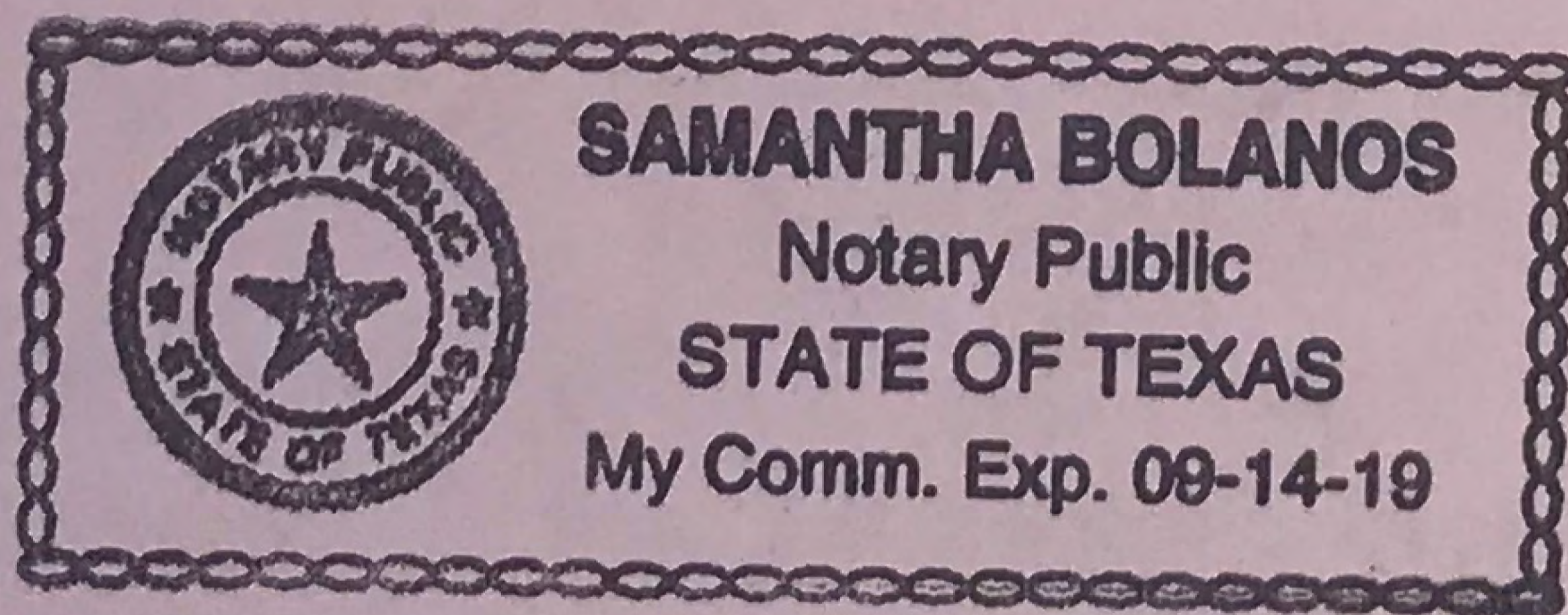

[Signature]
Notary Public Signature

2018 Applicant Eligibility Certification

By: [Signature]
Signature of Authorized Representative

ALETHA F. SMITH
Printed Name

BOARD MEMBER
Title

05/16/2018
Date

THE STATE OF Texas §
COUNTY OF Brazos §

Before me, a notary public, on this day personally appeared Aletha F. Smith, known to me to be the person whose name is subscribed to the foregoing document and, being by me first duly sworn, declared and certified that the statements therein contained are true and correct.

GIVEN UNDER MY HAND AND SEAL OF OFFICE this 16 day of May, 2018

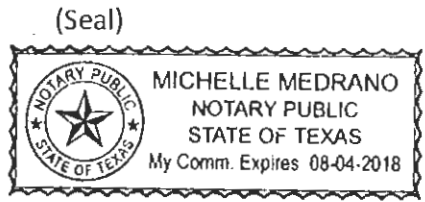

[Signature]
Notary Public Signature

2018 Applicant Eligibility Certification

By: [Signature]
Signature of Authorized Representative

Tomi R. Johnson
Printed Name

Title
May 17, 2018
Date

THE STATE OF Texas §
COUNTY OF Brazos §

Before me, a notary public, on this day personally appeared Tomi Johnson, known to me to be the person whose name is subscribed to the foregoing document and, being by me first duly sworn, declared and certified that the statements therein contained are true and correct.

GIVEN UNDER MY HAND AND SEAL OF OFFICE this 17 day of May, 2018



[Signature]
Notary Public Signature

2018 Applicant Eligibility Certification

By: Warren Roberts
Signature of Authorized Representative

WARREN Roberts
Printed Name

President
Title

5-15-2018
Date

THE STATE OF TX §
§
COUNTY OF BRAZOS §

Before me, a notary public, on this day personally appeared WARREN ROBERTS, known to me to be the person whose name is subscribed to the foregoing document and, being by me first duly sworn, declared and certified that the statements therein contained are true and correct.

GIVEN UNDER MY HAND AND SEAL OF OFFICE this 15th day of MAY, 2018

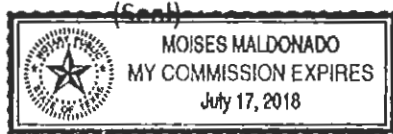

[Signature]
Notary Public Signature



**TEXAS DEPARTMENT OF
HOUSING & COMMUNITY AFFAIRS**
Building Homes. Strengthening Communities.

TAB 4

Multifamily Direct Loan Certification

Multifamily Direct Loan Certification

Multifamily Direct Loan Certification is included behind this tab.

****The form should be executed, notarized, and included in the full application document.****

The form for the certification will be posted to the Department's website at

<http://www.tdhca.state.tx.us/multifamily/apply-for-funds.htm>

Multifamily Direct Loan Certification

I (We) hereby make application to the Texas Department of Housing and Community Affairs (the "Department") for an award of Multifamily Direct Loan funds, which may be composed of HOME Investment Partnerships Program ("HOME"), Tax Credit Assistance Program Repayment Funds "TCAP RF," Neighborhood Stabilization Program Round 1 Program Income ("NSP1 PI"), and/or National Housing Trust Fund ("NHTF"). The undersigned hereby acknowledges that an award by the Department does not warrant that the Development is deemed qualified to receive such award. I (We) agree that the Department or any of its directors, officers, employees, and agents will not be held responsible or liable for any representations made to the undersigned or its investors relating to the Multifamily Direct Loan; therefore, I (We) assume the risk of all damages, losses, costs, and expenses related thereto and agree to indemnify and save harmless the Department and any of its officers, employees, and agents against any and all claims, suits, losses, damages, costs, and expenses of any kind and of any nature that the Department may hereinafter suffer, incur, or pay arising out of its decision concerning this application for Multifamily Direct Loan funds or the use of information concerning the Multifamily Direct Loan.

On behalf of the Applicant and all affiliates of the Applicant (hereinafter "Applicant"), I (We) hereby certify that the Applicant is familiar with the state Rules, as published in 10 TAC Chapters 1, 2, 10, and 13, as well as Chapters 11 and 12 as applicable. I (We) hereby acknowledge that this Application is subject to disclosure under Chapter 552, Texas Government Code, the Texas Public Information Act, unless a valid exception exists.

I (We) hereby assert that the information contained in this Application as required or deemed necessary by the materials governing the Multifamily Direct Loan are true and correct and that I (We) have undergone sufficient investigation to affirm the validity of the statements made and the Department may rely on any such statements.

Further, I (We) hereby assert that I (We) have read and understand all the information contained in the application. By signing this document, I (We) affirm that all statements made in this government document are true and correct under penalty of Chapter 37 of the Texas Penal Code titled Perjury and Other Falsification and subject to criminal penalties as defined by the State of Texas. TEX. PENAL CODE ANN. §37.01 et seq. (Vernon 2011).

I (We) understand and agree that if false information is provided in this Application which has the effect of increasing the Applicant's competitive advantage, the Department will disqualify the Applicant and may hold the Applicant ineligible to apply for Multifamily Direct Loan funds or until any issue of restitution is resolved. If false information is discovered after the award of

Multifamily Direct Loan funds, the Department may terminate the Applicant's written agreement and recapture all Multifamily Direct Loan funds expended.

I (We) shall not, in the provision of services, or in any other manner discriminate against any person on the basis of age, race, color, religion, sex, national origin, familial status, or disability. Verification of any of the information contained in this application may be obtained from any source named herein.

I (We) have written below the name of the individual authorized to execute the Multifamily Direct Loan agreement and any and all future Multifamily Direct Loan commitments and contracts related to this application. If this individual is replaced by the organization, I (We) must inform the Department within 30 days of the person authorized to execute agreements, commitment and/or contracts on behalf of the Applicant.

I (We) certify that no person or entity that would benefit from the award of Multifamily Direct Loan funds has committed to providing a source of match.

I (We) certify that I (We) will meet, Texas Minimum Construction Standards, 2010 ADA Standards for Accessible Design, as well as the Fair Housing Accessibility Standards and Section 504 of the Rehabilitation Act of 1973 as further detailed in 10 TAC Chapter 1, Subchapter B. I (We) certify that the Development will meet all local building codes or standards that may apply as well as the Uniform Physical Conditions Standards in 24 CFR §5.705

I (We) certify that if Department funds have a first lien position in the project for which assistance is being requested, assurance of completion of the development will be provided in the form of payment and performance bonds in the full amount of the construction contract, running to the Department as obligee, or equivalent guarantee in the sole determination of the Department.

I (We) certify that if refinancing is a component of the proposed development the Applicant must confirm that Multifamily Direct Loan funds will not be used to replace loans, grants or other financing by any other Federal program, or in violation of the provisions of 10 TAC §13.3(e).

I (We) certify that if other federal or governmental assistance is used in the financing of this development I (We) will notify the Texas Department of Housing and Community Affairs.

I (We) certify that I (We) do not and will not knowingly employ an undocumented worker, where "undocumented worker" means an individual who, at the time of employment, is not lawfully admitted for permanent residence to the United States or authorized under law to be employed in that manner in the United States.

If, after receiving a public subsidy, I (We), am convicted of a violation under 8 U.S.C Section 1324a (f), I (We) shall repay the amount of the public subsidy with interest, at the rate and according to the other terms provided by an agreement under Texas Government Code Section 2264.053, not later than the 120th day after the date TDHCA notifies Name of Applicant of the violation.

On behalf of the Applicant, I (We) hereby certify that the Applicant is familiar with the provisions of the federal HOME Final Rule, as published in 24 CFR Part 92, and other related administrative rules and regulations and court rulings issued by the Federal government or State of Texas with respect to the HOME Investment Partnerships Program and all Developments eligible to receive HOME funds will comply with such rules during the application process and, in the event of award of HOME funds, for the duration of the proposed Development.

If applying under the Supportive Housing/Soft Repayment set-aside, on behalf of the Applicant, I (We) hereby certify that the Applicant is familiar with the provisions of the interim Housing Trust Fund rule, as published in 24 CFR Part 93, and other related administrative rules and regulations and court rulings issued by the Federal government or State of Texas with respect to the NHTF and all Developments eligible to receive NHTF funds will comply with such rules during the application process and, in the event of award of NHTF funds, for the duration of the proposed Development

Lead Based Paint

I (We) certify that documentation of compliance with the Texas Environmental Lead Reduction Rules in 25 TAC Chapter 295, Subchapter I or 24 CFR Part 35 (Lead Safe Housing Rule), as applicable, will be maintained in project files. I (We) understand that for Developments subject to 24 CFR Part 25, standard forms are available in the Federal Register , as indicated by the sources noted below.

- 1) Applicability 24 CFR §35.115 – A copy of a statement indicating that the property is covered by or exempt from Lead Safe Housing Rule.
 - a) If the property is exempt, the file should include the reason for the exemption and no further documentation is required.
 - b) if the property is covered by the Rule, the file should include the appropriate documentation to indicate basic compliance, as listed below:
 - i) Summary Paint Testing Report or Presumption Notice 24 CFR §35.930(a) – A copy of any report to indicate the presence of lead-based paint (LBP) for projects receiving up to \$5,000 per unit in rehabilitation assistance. If no testing was performed, then LBP is presumed to be on all disturbed surfaces;

- ii) Notice of Evaluation 24 CFR §35.125(a) – A copy of a notice demonstrating that an evaluation summary was provided to residents following a lead-based-paint inspection, risk assessment or paint testing;
- iii) Clearance Report 24 CFR §35.930(b) (3) – A report indicating a “clearance examination” was performed of the work site upon completion; and
- iv) Notice of Hazard Reduction Completion 24 CFR §35.125(b) – Upon completion, a copy of a notice to show that a LBP remediation summary was provided to residents.

Threshold Certification

On behalf of the Applicant and all affiliates of the Applicant (hereinafter “Applicant”), I (We) hereby certify that the Applicant is familiar with the provisions and requirements of the Multifamily Direct Loan Notice of Funding Availability (NOFA) approved by the Department’s Governing Board on December 15, 2016, for which I (We) am applying.

I (We) understand that housing units subsidized by Multifamily Direct Loan funds must be affordable to low, very low or extremely low-income persons. I (We) understand that mixed income rental developments may only receive funds for units that meet the Multifamily Direct Loan affordability standards. I (We) understand that all Applications intended to serve persons with disabilities must adhere to the Department’s Integrated Housing Rule at 10 TAC §1.15.

I (We) understand that, pursuant to 10 TAC §13.11(p), all contractors, consulting firms, Borrowers, Development Owners and Contract Administrators must sign and submit the appropriate documentation with each draw to attest that each request for payment of Multifamily Direct Loan funds is for the actual cost of providing a service and that the service does not violate any conflict of interest provisions in 24 CFR Part 92.

I (We) certify that I (We) am eligible to apply for funds or any other assistance from the Department. I (We) certify that all audits are current at the time of application. I (We) certify that any Audit Certification Forms have been submitted to the Department in a satisfactory format on or before the application deadline for funds or other assistance pursuant to 10 TAC §1.3(b). I (We) certify that, the Development will meet the broadband infrastructure requirements of 81 FR 92626, and that these costs are included in the Application.

All applicants applying under the 2018-1 Multifamily Direct Loan Notice of Funding Availability (NOFA) must read and initial after each of the following sections regarding federal cross cutting requirements in the boxes below.

HUD Section 3

I (We) hereby agree that the work to be performed in connection with any award of HOME or NHTF funds is subject to the requirements of section 3 of the Housing and Urban Development Act of 1968, as amended, 12 U.S.C. 1701u (“Section 3”). The purpose of Section 3 is to ensure that employment and other economic opportunities generated by HUD assistance or HUD-assisted projects covered by Section 3, shall, to the greatest extent feasible, be directed to low- and very low-income persons, particularly persons who are recipients of HUD assistance for housing. I (We) agree to comply with HUD's regulations in 24 CFR Part 135, which implement Section 3. For more information about HUD Section 3, please reference the TDHCA website dedicated to Section 3 at: <http://www.tdhca.state.tx.us/program-services/hud-section-3/index.htm>



(initial)

Environmental

I (We) understand that the environmental effects of each activity carried out with an award of HOME funds must be assessed in accordance with the provisions of National Environmental Policy Act of 1969 (NEPA) (42 U.S.C. §4321 et seq.) and the related activities listed in HUD’s implementing regulations at 24 C.F.R. parts 50, 51, 55 and 58 (NEPA regulations). Each such activity must have an environmental review completed and support documentation prepared complying with the NEPA and NEPA regulations. **No loan may close or funds be committed to an activity before the completion of the environmental review process, including the requirements of 24 CFR Part 58, and the Department has provided written clearance.**

The Department as the Responsible Entity must ensure that environmental effects of the property are assessed in accordance with the provisions of the National Environmental Policy Act of 1969 and the related authorities listed in HUD’s implementing regulations at 24 CFR Parts 50 and 58.

I (We) certify that all parties involved in any aspect of the development process began the project with no intention of using Federal assistance.

I (We) certify that as of the date of the Multifamily Direct Loan application all project work, other than as allowed in 24 CFR. Part 58, has ceased.

I (We) understand that the environmental effects of each activity carried out with an award of NHTF funds must be assessed in accordance with the provisions of CPD Notice 16-14.

I (We) certify that I (we) have read and understand the requirements in 24 CFR §58.22 or CPD Notice 16-14, and I (we) understand that **acquisition of the site, even with non-HUD funds, prior to completion of the environmental review process will jeopardize any federal funding.**

I (We) certify that we will not engage in any choice limiting actions until the site has achieved Environmental Clearance as required in CPD Notice 16-14 or 24 CFR. Part 58, as applicable. **Choice-limiting activities include but are not limited to these examples:**

- Acquisition of land, except through the use of an option agreement, regardless of funding source;
- Closing on loans including loans for interim financing;
- Signing a construction contract.



(initial)

Relocation and Anti-Displacement

The property proposed for this Application is _____ is not occupied. (check one)

If occupied, the occupant(s) are owners _____ tenants _____

Displacement of Existing Tenants

I (We) certify that that the work to be performed in connection with any award of federal funds is subject to Uniform Relocation Assistance and Real Property Acquisition Policies Act of 1970 (“URA”), as amended, and implementing regulations at 49 CFR Part 24. Consistent with the goals and objectives of activities assisted under the Act and HUD Handbook 1378, if the Development is eligible for federal funds the Applicant must prepare and submit the following to TDHCA with the Multifamily Uniform Application:

- 1) A detailed explanation of the reasons for displacement relocation;
- 2) A detailed plan of the relocation, including evidence of comparable replacement housing;
- 3) A copy of the General Information Notice (signed by the tenant or sent Certified Mail, return recipient requested) sent to all tenants on the Rent Roll listed with the Multifamily Direct Loan Application, and
- 4) Estimated costs and funding sources available to complete the permanent relocation.

Demolition and Conversion

I (We) certify that that the work to be performed in connection with any award of federal funds is subject to 24 CFR Part 42 and Development Owner will replace all occupied and vacant

occupiable low-income housing that is demolished or converted to a use other than low-income housing as a direct result of the project. All replacement housing will be provided within three (3) years after the commencement of the demolition or conversion. Before receiving a commitment of federal funds for a project that will directly result in demolition or conversion, the project owner will make the information public in accordance with 24 CFR Part 42 and submit the information to TDHCA along with the following information in writing at application:

- 1) The location map, address, and number of dwelling units by bedroom size of lower income housing that will be demolished or converted to use other than as lower income housing as a direct result of the project;
- 2) A time schedule for the commencement and completion of the demolition and conversion;
- 3) To the extent known, the location, map, address, and number of dwelling units by bedroom size of the replacement housing that has been or will be provided;
- 4) The amount and source of funding and a time schedule for the provision of the replacement housing;
- 5) The basis for concluding that the replacement housing will remain lower income housing beyond the date of initial occupancy;
- 6) Information demonstrating that any proposed replacement of housing units with similar dwelling units (e.g. a 2-bedroom unit with two 1-bedroom units) or any proposed replacement of efficiency or SRO units with units of a different size is appropriate and consistent with the housing needs of the community; and
- 7) The name and title of the person or persons responsible for tracking the replacement of lower income housing and the name and title of the person responsible for providing relocation payments and other relocation assistance to any lower-income person displaced by the demolition of any housing or the conversion of lower-income housing to another use.

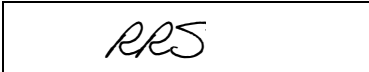

(initial)

2017 Multifamily Direct Loan Certification

By: [Signature]

Signature of Authorized Representative

Rick R. Sims

Printed Name

Executive Director

Title

2-28-2017

Date

THE STATE OF TEXAS

COUNTY OF Dallas

I, the undersigned, a Notary Public in and for said County and State, do hereby certify that name is signed to the foregoing statement, and who is known to be one in the same, has acknowledged before me on this date, that being informed of the contents of this statement, executed the same voluntarily on the date same foregoing statement bears.

GIVEN UNDER MY HAND AND SEAL OF OFFICE this 28th day of February, 17

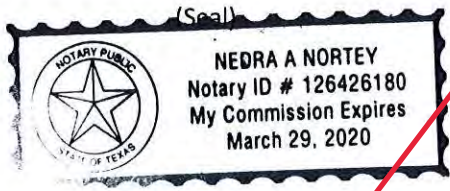

Nedra Northey
Notary Public Signature

2018 Multifamily Direct Loan Certification

By: [Signature]

Signature of Authorized Representative

Rick Sims

Printed Name

Executive Director

Title

8.31.2018

Date

THE STATE OF ~~TEXAS~~ Louisiana §

Parish §

COUNTY OF Ouachita §

Before me, a notary public, on this day personally appeared Rick Sims, known to me to be the person whose name is subscribed to the foregoing document and, being by me first duly sworn, declared and certified that the statements therein contained are true and correct.

GIVEN UNDER MY HAND AND SEAL OF OFFICE this 30th day of August, 2018

(Seal)

[Signature]

Notary Public Signature

ROBBY D. WILLIAMS

#51566



**TEXAS DEPARTMENT OF
HOUSING & COMMUNITY AFFAIRS**
Building Homes. Strengthening Communities.

TAB 5

Applicant Information Page



**TEXAS DEPARTMENT OF
HOUSING & COMMUNITY AFFAIRS**
Building Homes. Strengthening Communities.

TAB 6

Self – Score

Competitive Housing Tax Credit Selection Self-Score

This form will self-populate based on scoring selections made throughout the Application. Applicant should refer to this form to ensure that scoring selections are accurate prior to submitting the Application. Corrections must be made in the applicable section(s) of the Application. Highlighted rows indicate scoring items for both 9% HTC and Direct Loan applications. Additional scoring for Direct Loan applications can be found at 10 TAC §13.6.

Criteria Promoting Development of High Quality Housing

Point Item Description	QAP Reference	Points Selected
Unit Sizes	§11.9(b)(1)(A)	0
Unit and Development Features	§11.9(b)(1)(B)	0
Sponsor Characteristics	§11.9(b)(2)	0
High Quality Housing Total		0

Criteria to Serve and Support Texans Most In Need

Point Item Description	QAP Reference	Points Selected
Income Levels of Tenants	§11.9(c)(1)	0
Rent Levels of Tenants	§11.9(c)(2)	0
Tenant Services	§11.9(c)(3)	11
Opportunity Index	§11.9(c)(4)	7
Underserved Area	§11.9(c)(5)	5
Tenant Populations with Special Needs	§11.9(c)(6)	0
Proximity to the Urban Core	§11.9(c)(7)	0
Readiness to Proceed in Disaster Impacted Counties	§11.9(c)(8)	
Serve and Support Texans Most in Need Total		23

Criteria Promoting Community Support and Engagement

Point Item Description	QAP Reference	Points Selected
Local Government Support	§11.9(d)(1)	
Commitment of Development Funding by Local Political Subdivision	§11.9(d)(2)	0
Declared Disaster Area	§11.9(d)(3)	0
Quantifiable Community Participation	§11.9(d)(4)	
Community Support from State Representative	§11.9(d)(5)	
Input from Community Organizations	§11.9(d)(6)	
Concerted Revitalization Plan	§11.9(d)(7)	
Community Support and Engagement Total		0

Criteria Promoting the Efficient Use of Limited Resources and Applicant Accountability

Point Item Description	QAP Reference	Points Selected
Financial Feasibility	§11.9(e)(1)	0
Cost of Development per Square Foot	§11.9(e)(2)	12
Pre-application Participation	§11.9(e)(3)	0
Leveraging of Private, State, and Federal Resources	§11.9(e)(4)	0
Extended Affordability	§11.9(e)(5)	0
Historic Preservation	§11.9(e)(6)	0
Right of First Refusal	§11.9(e)(7)	0
Funding Request Amount	§11.9(e)(8)	0
Efficient Use of Limited Resources and Applicant Accountability Total		12
Point Deductions	§11.9(f)	
Total Application Self Score		35



**TEXAS DEPARTMENT OF
HOUSING & COMMUNITY AFFAIRS**
Building Homes. Strengthening Communities.

TAB 7

Site Information Form (Part I)

Site Information Form Part I

Self Score Total: 35

1. Development Address (All Programs)

Aproximate 2008 HWY 21 East Bryan
 Address City

8 76086 Brazos Urban
 Region Zip County Rural/Urban

2. Census Tract Information (All Programs)

48041000300 No Median Household Income: 45,313 ~~44804.00~~ Quartile: 3q Poverty Rate: 13.4 ~~17.5~~

Census Tract Number QCT? The poverty rate for the census tract is above 40% (55% for Regions 11 or 13), and the Undesirable Neighborhood Characteristics Report and required documentation has been submitted.
 (11 digits)

3. Resolutions (All Programs, if applicable) - §11.3

Check the boxes of true statements below. Resolutions must be provided to demonstrate eligibility for any **unchecked** item.

- Twice the State Average Per Capita.** The proposed Development is **NOT** located in a municipality or a county that has more than twice the state average of units per capita supported by Tax Credits or Private activity Bonds. (QAP §11.3(c))
- One Mile Three Year Rule.** The proposed Development is located outside an MSA or in a county with a population of less than one million **OR** is **NOT** a New Construction or Adaptive Reuse development that will be located one mile or less from a new construction or terminated/withdrawn HTC or Bond development serving the same type of household. (QAP §11.3(d))
- Limitations on Developments in Certain Census Tracts.** The proposed Development is **NOT** a New Construction or Adaptive Reuse development that will be located in a census tract that has more than 20% HTC units per total households. (QAP §11.3(e))

4. Zoning [§10.204(11)] and Flood Zone Designation [§10.101(a)(1)] (All Programs)

Development Site is appropriately zoned? No Zoning Designation: C-3 (Commercial)

Flood Zone Designation: x Entire Development Site is outside the 100 year floodplain. Yes

5. School Rating [§2306.6710(a)]; [§10.101(a)(3)(B)(iv)] (All Programs)

Residents of the proposed development will attend:

School Name	Grades X through X	Met Standard Rating?		
		2015	2016	2017
Bonham Elementary	PK through 6	Yes	Yes	Yes
Arthur L. Davila	7 through 8	Yes	Yes	Yes
James Earl Rudder	9 through 12	Yes	No	Yes
	through			
	through			

- School district has no attendance zones and the closest schools are listed.
- The Development Site is located within the attendance zone of an elementary school, a middle school or a high school that does not have a 2017 Met Standard rating by the Texas Education Agency, and the Undesirable Neighborhood Characteristics Report and required documentation has been submitted.

If revised form submitted, date of submission: _____







**TEXAS DEPARTMENT OF
HOUSING & COMMUNITY AFFAIRS**
Building Homes. Strengthening Communities.

TAB 8

Supporting Documentation for the Information (Part I)

Supporting Documentation for the Site Information Form Part I

- Street Map with Site Drawn and Identified 
- Census Tract Map with Development Site Identified 
<https://factfinder.census.gov/faces/nav/jsf/pages/searchresults.xhtml?refresh=t>
- Twice the State Average of Units Per Capita Resolution
- One Mile Three Year Resolution or evidence of other exception
- Housing Tax Credit Units per Total Household Resolution
- Evidence of Zoning and/or Evidence of Re-Zoning Process
- Evidence of Flood Zone Designation 
- Educational Quality (all Applications)
 - School Attendance Zone Map with Development labeled;
 - 2017 TEA accountability information for each school, and 
 - UNCR if a school in the attendance zone has not achieved Met Standard for three consecutive years and has failed by at least one point in the most recent year. 
- For Tax-Exempt Bond Applications the resolution of no objection to satisfy requirements of §10.204(4) of the Uniform Multifamily Rules is included
- For Tax-Exempt Bond Applications the resolution of no objection to satisfy requirements of §10.204(4) of the Uniform Multifamily Rules is not included and will be provided under separate cover no later than 14 days prior to the Board meeting selected in Tab 1b

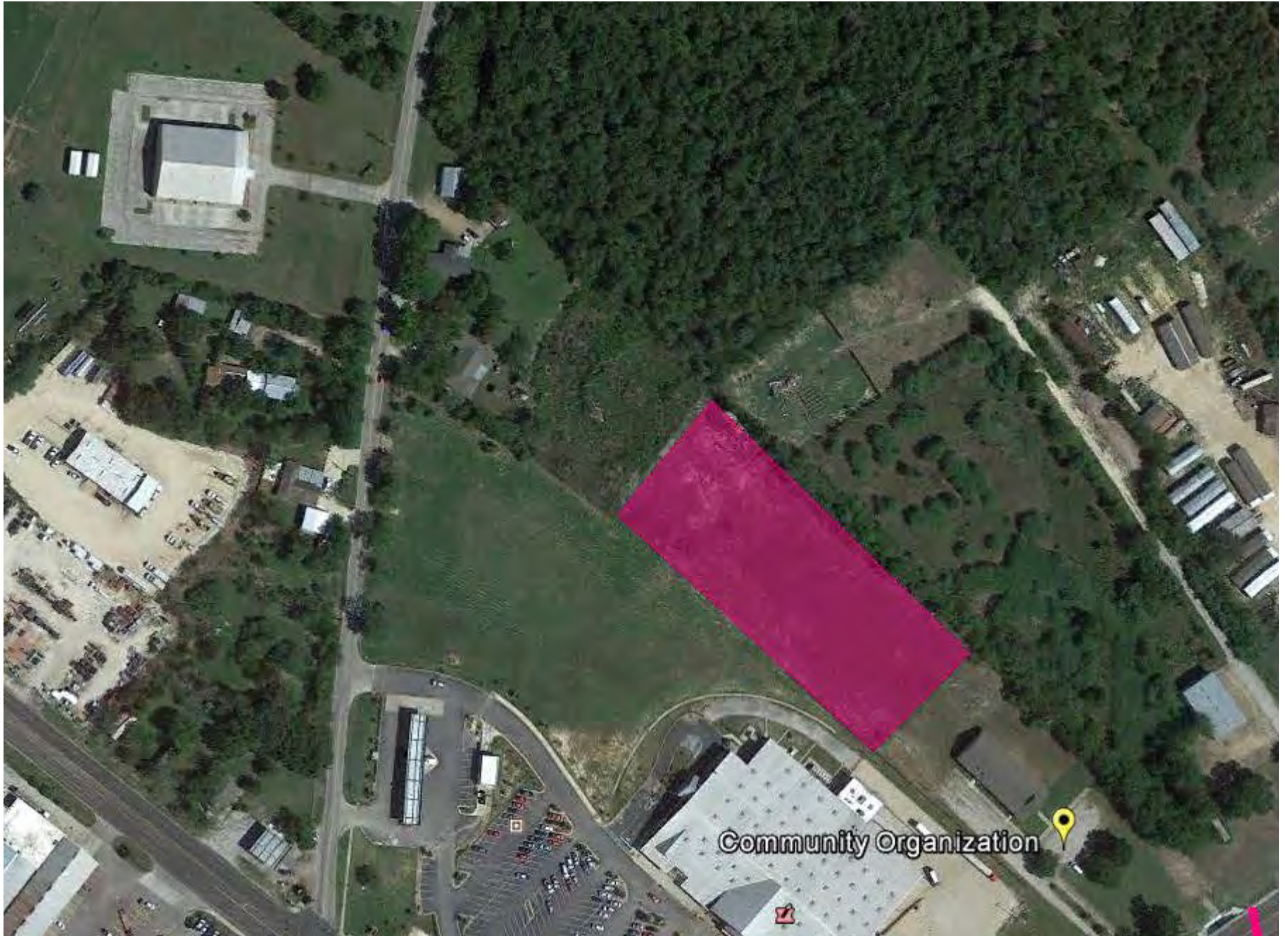

May 4, 2018

Mr. Terry Roberts
No Limits IEDC
2002 Highway 21 East
Bryan, TX 77803



Re: zoning verification for land and improvements located at **2002 Highway 21 East** specifically being Lot 3 and 6 of Block 16 in the SFA #10 League in Bryan, Brazos County, Texas.

Mr. Roberts,

We are the authority responsible for the enforcement of zoning matters in the geographic area in which the above-referenced property is situated.

This letter is to verify that the referenced property is zoned a mixture of Commercial District (C-3) which extends northwest approximately 490-520 feet from East State Highway 21 and Agricultural-Open District (A-O) for the remainder of the property (see attached zoning map). There are no overlay districts which affect this property. The adjacent properties are also zoned A-O and C-3, as well as Retail District (C-2).

The A-O District allows for the development of a single-family detached dwelling by right. This includes the installation of a modular home, but excludes manufactured or mobile homes. The installation of a manufactured home can only occur with prior approval of a Conditional Use Permit from the Planning and Zoning Commission. The C-3 District does not allow for the development of a single-family detached dwelling.

This information was researched on **May 4, 2018**, by the undersigned, per request and as a public service. The undersigned certifies that the above information contained herein is believed to be accurate and is based upon, or relates to the information supplied by the requestor. The Authority assumes no liability for errors and omissions. All information was obtained from public records, which may be inspected during regular business hours.

Please feel free to contact me if you have any questions regarding this letter at (979) 209-5030 or at akay@bryantx.gov.

Thank you,

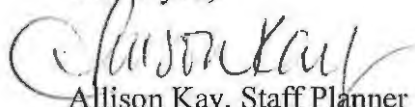
Allison Kay, Staff Planner
Development Services
City of Bryan



- HOME
- ABOUT PD&R
- RESEARCH & PUBLICATIONS
- DATA SETS
- INITIATIVES
- QUICK LINKS
- EVENTS
- Share



2017 and 2018 Small DDAs and QCTs

Map Options : Clear | Reset | Full Screen

- QCT Legend Tract Outline LIHTC Project 2018 Qualified Census Tracts
- SADDA Legend (%) FMR Boundary SADDA Boundary 2018 Small DDA (Entire ZIP code) Split ZCTA*

*SDDA designation for split ZCTAs is not shown on map. Please refer to the Metro SDDA designation list to determine designation status (DDA2018M.pdf).

Hide the overview of SADDA

The 2018 Qualified Census Tracts (QCTs) and Difficult Development Areas (DDAs) are effective January 1, 2018. The 2018 designations use data from the 2010 Decennial census and three releases of 5-year tabulations from the American Community Survey (ACS): 2009-2013; 2010-2014; and 2011-2015. The designation methodology is explained in the federal Register notice published September 11, 2017.

Map Options

- 17 Current Zoom Level
- Show SADDA Outlines (Zoom 10+)
- Color QCT Qualified Tracts (Zoom 7+)
- Show Tracts Outline (Zoom 11+)
- Show FMR Outlines (Zoom 4+)
- Show LIHTC Projects (Zoom 11+)

Click here for full screen map

Select Year

- 2018
- 2017



QCT for 2018	
Tract	3.00
County	Brazos County
State	TX
Status (2018)	Not Qualified
Poverty Rate	13.8%
Ratio of Tract Median Income to Tract Income Limit	0.721
Full Tract Number	48041000300

About PD&R

- Delegations of Authority and Order of Succession
- Events
- HUD at 50
- HUD Secretary's Awards
- PD&R Careers

Initiatives

- Aging Research and Resources
- Aligning Affordable Rental Housing
- Interagency Physical Inspection Alignment

Research

- Case Studies
- Data Sets
- Periodicals
- Regulatory Barriers Clearinghouse
- Reports

City of Bryan Zoning Map

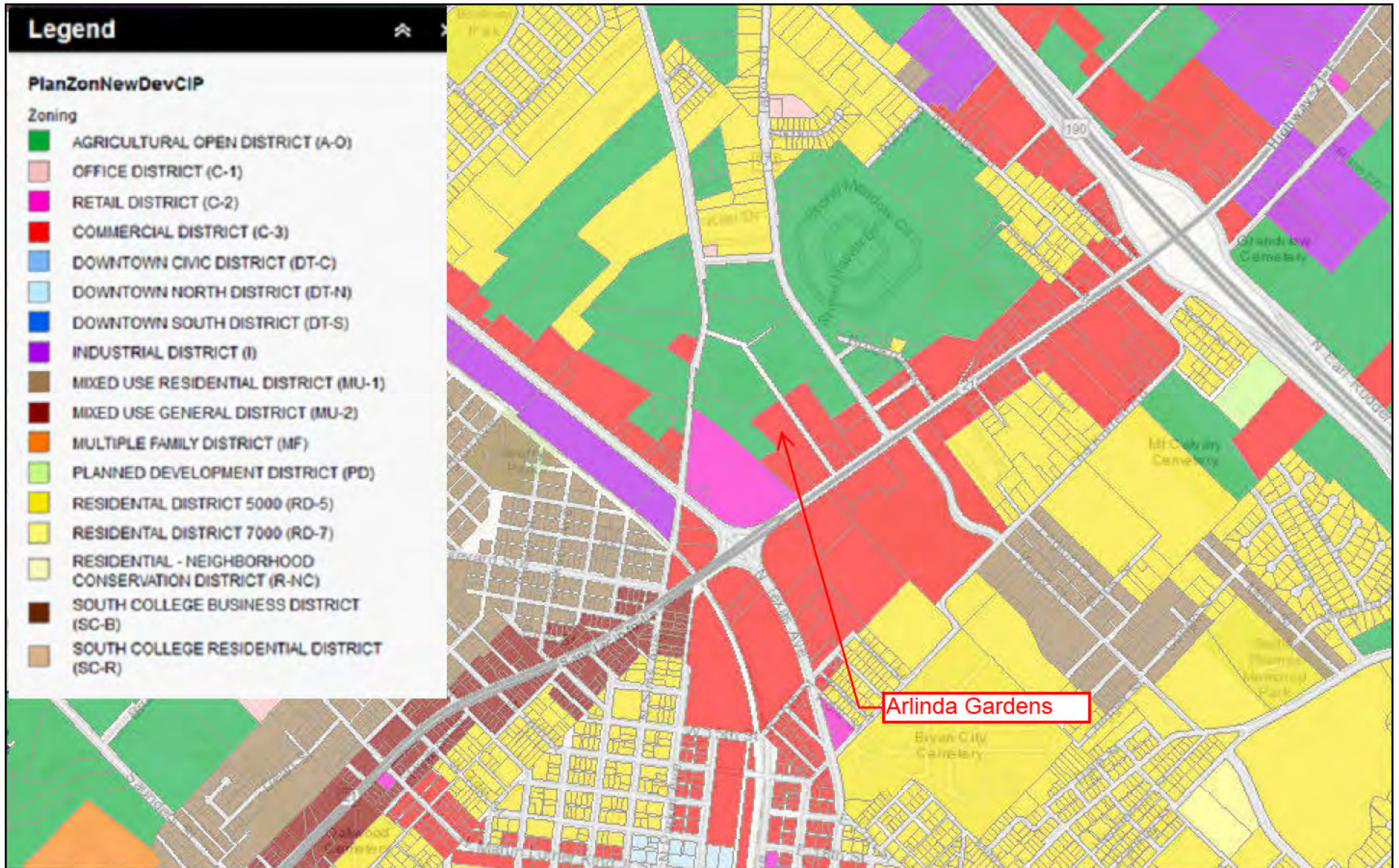

February 26, 2017

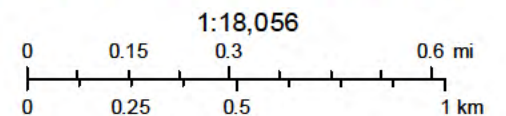

Sources: Esri, HERE, DeLorme, Intermap, increment P Corp., GEBCO, USGS, FAO, NPS, NRCAN, GeoBase, IGN, Kadaster NL, Ordnance Survey,

City of Bryan Geographic Information Services
For Reference Purposes Only - © 2016 City of Bryan, Texas

Section 130-15. C-3, Commercial District.

(a) *General purpose and description.* The C, Commercial District is intended predominantly for heavy retail and commercial uses of a service nature which typically have operating characteristics or traffic service requirements generally compatible with typical retail or shopping, but generally not with residential environments. Operating characteristics which may be typical of uses permitted in the Commercial District include service oriented, may sell used goods, require warehouse storage and delivery areas, and have a greater service radius than retail stores.

(b) *Permitted uses:*

Any permitted use allowed in the Retail District with the addition of:

- Amusement arcade (video arcade);
- Automobile repair;
- Automobile sales/rental/service;
- Boat sales/rental/service;
- Bus terminal/station;
- Commercial amusement, (indoor);
- Commercial amusement, (outdoor);
- Commercial bakery;
- Farm equipment sales and service;
- Feed store;
- Fraternity/sorority house;
- Gaming establishments;
- Ice company (sales);
- Ice company (wholesale);
- Indoor archery and shooting range;
- Landscape service;
- Laundries, commercial;
- Lumberyard;
- Manufactured home display and sales;
- Mini-warehouse/self-storage;
- Motorcycle sales/rental/service;
- Nightclub or tavern;
- Office--Showroom/warehouse;
- Theater--Outdoor (amphitheater);
- Overnight delivery company;
- Paper/chemical suppliers;
- Parking lots (non-paid for nonresidential use);
- Plumbing service;
- Portable/small commercial structures--Permanent;
- Portable/small commercial structures--Seasonal;
- Printing company;
- Private utility company (with outside storage);

- Recycling collection point;
- Recreational vehicle (RV) park;
- Tool and machinery rental;
- Truck repair/truck stop;
- Veterinary services (no outdoor runs or pens).

(c) *Conditional uses:*

Any conditional use allowed in the Retail District with the addition of:

- Cabinet shop;
- Cemetery;
- College or university;
- Flea market;
- Golf course or country club;
- Heliport or helistop;
- Manufacturing;
- Machine shop;
- Moving company;
- Multifamily dwelling;
- Refuse systems;
- Rodeo grounds;
- Stable--Commercial.

(d) *Height regulations.* Refer to building setbacks and lot standards, article IV, chapter 62.

(e) *Lot area and setback requirements.* Refer to building setbacks and lot standards, article IV, chapter 62.

(f) *Parking regulations.* Refer to access and off-street parking, article VI, chapter 62.

(g) *Other regulations:*

- (1) As established in all other applicable sections and/or ordinances.
- (2) Establishments selling alcoholic beverages shall not be located within 300 feet of a public school, church, or a public hospital. The distance shall be measured as specified in the city Code.
- (3) Detached Dwelling Units permitted in this district shall conform to standards as specified in the RD-5 district. Duplex, townhouse, and patio home dwellings permitted conditionally in this district shall conform to standards as specified in section 130-33.
- (4) Where activity has ceased for one or more years on a property where the most recent land use is a permitted use in this district, a site plan shall be filed in accordance with the provisions of nonresidential and multifamily development, article III of chapter 62, before activity on the property may resume. Detached Dwelling Units, patio homes, townhouses, and duplexes are exempt from this provision.
- (5) No temporary structures, such as recreational vehicles, travel trailers, construction trailers, or mobile homes may be used for on-site dwelling purposes.

- (6) The following regulations are to control contamination of the air, water, or the environment and to safeguard the health, safety, and general welfare of the public. No machine, process or procedure shall be employed on any property in the city, in which:
- a. Emission of smoke, dust, noxious, toxic, or lethal gasses are detectable beyond the perimeter of the property.
 - b. Vibration is discernible beyond the property line.
 - c. Noise above the average intensity of street traffic is discernible beyond the property line.
 - d. Materials are stored or accumulated in such a way that they may be carried by rainwater in natural drainage channels beyond the limits of the property, which are noxious, toxic, radioactive, or contain oil or grease.
- (7) Wireless telecommunication facilities shall be allowed only as provided for in section 130-34.
- (8) The following regulations pertain to portable/small commercial structures-permanent which are permitted in this district.
- a. Refer to building setbacks and lot standards, article IV, chapter 62.
 - b. All fire code requirements must be met.
 - c. A written agreement with the property owner for trash pickup must be provided.
 - d. All parking requirements must be met.
 - e. No portable/small commercial structures shall be allowed in parking lots that do not meet current construction standards or do not presently have an excess of parking for the existing structures utilizing the lot.
 - f. The site development review committee must approve vehicle circulation.
 - g. The structure must be properly anchored, either to the surface of the lot or it must be on a permanent foundation.
 - h. Landscaping must front a minimum of ten percent of the building's facade. Acceptable landscaping of portable/small commercial structures includes the following: raised planter boxes and at grade planting beds.
 - i. Restroom facilities for the employer and employees must be provided either inside the structure or via an agreement with the owner of the main structure on the site.
- (9) The following regulations pertain to portable/small commercial structures-seasonal which are permitted in this district. Certificate of occupancies for portable/small commercial structures-seasonal shall be granted for a maximum of 60 days, after which time the structure must be removed from the site. An additional certificate of occupancy shall not be granted for the same business for a minimum of six months.
- (10) Open storage is prohibited (except for materials for the resident's personal use or consumption, e.g., firewood, gardening materials, etc.).

- KEY TO NUMBERED STREETS
 1. CONROY ST
 2. GEORGE ST
 3. TISDALE ST
 4. MASON ST
 5. HOOPER ST
 6. FRANKFORT ST

10240000 FT

Still Creek
Tributary A

MCHANEY DR

TABOR ROAD

OLD HEARNE RD

Tributary A
West Fork

LIMIT OF
STUDY

Carters Creek
Tributary 27.3

NUCHES LANE

ZONE A

PROFILE
BASELINE

MORSE
COURT

ZONE AE

Carters Cree
Tributary B

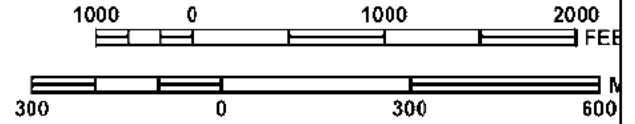

PANEL 0205F

FIRM
FLOOD INSURANCE RATE MAP
BRAZOS COUNTY,
TEXAS
AND INCORPORATED AREAS

PANEL 205 OF 475
 (SEE MAP INDEX FOR FIRM PANEL LAYOUT)

CONTAINS:

COMMUNITY	NUMBER	PANEL	SUFFIX
BRAZOS COUNTY	481195	0205	F
BRYAN, CITY OF	483082	0205	F

Notice to User: The Map Number shown below should be used when placing map orders; the Community Number shown above should be used on insurance applications for the subject community.



MAP NUMBER
48041C0205F

MAP REVISED
APRIL 2, 2014

Federal Emergency Management Agency

NATIONAL FLOOD INSURANCE PROGRAM

Arlinda Gardens



30° 41' 15"

96° 22' 30"

07 52 000mE

This is an official copy of a portion of the above referenced flood map. It was extracted using F-MIT On-Line. This map does not reflect changes or amendments which may have been made subsequent to the date on the title block. For the latest product information about National Flood Insurance Program flood maps check the FEMA Flood Map Store at www.msc.fema.gov

Elementary School Attendance Zones 2017-18

Arlinda Gardens Supportive Housing

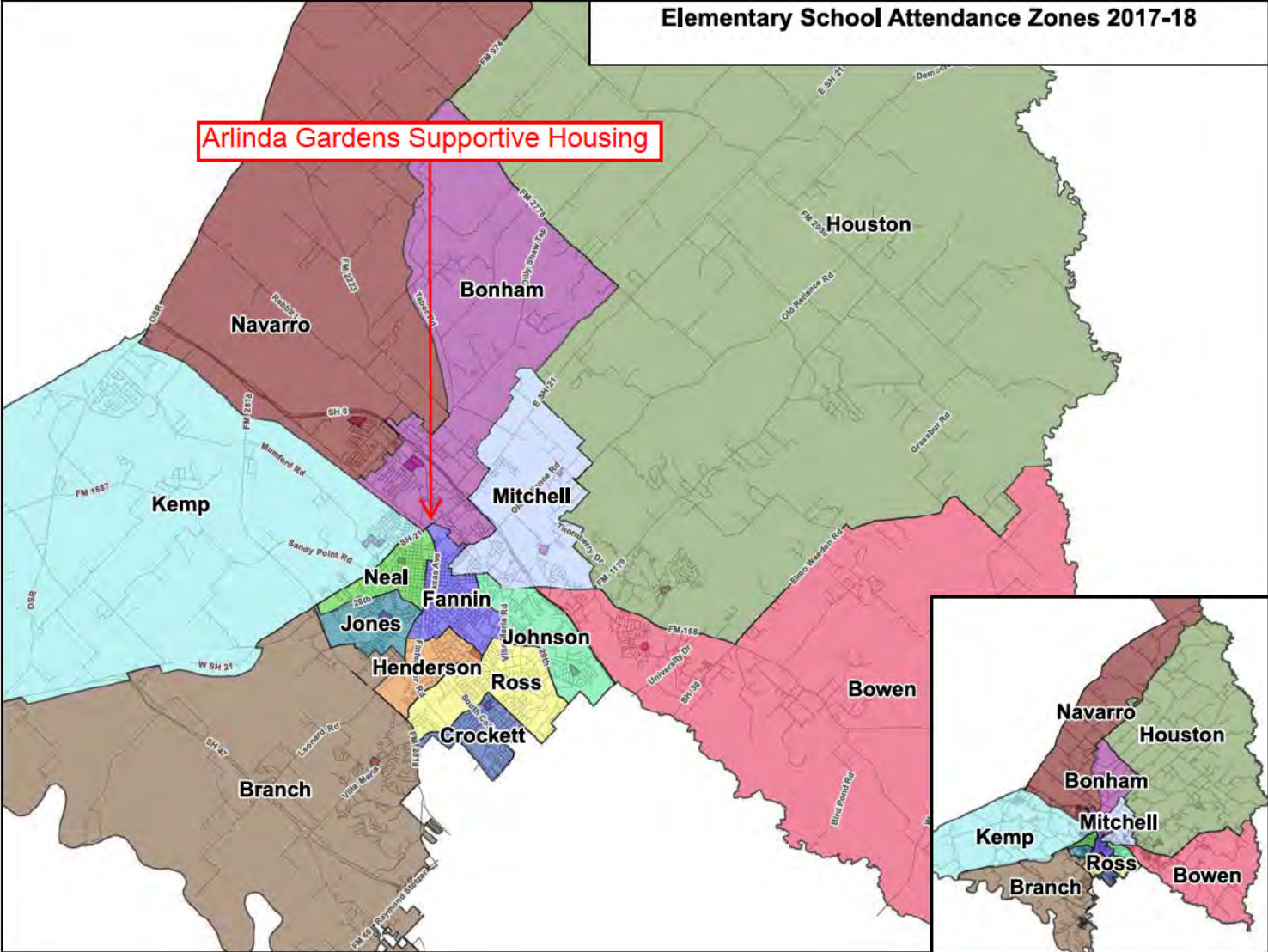

Middle School Attendance Zones 2017-18

Arlinda Gardens Supportive Housing

Davila

SFA

Davila

SFA

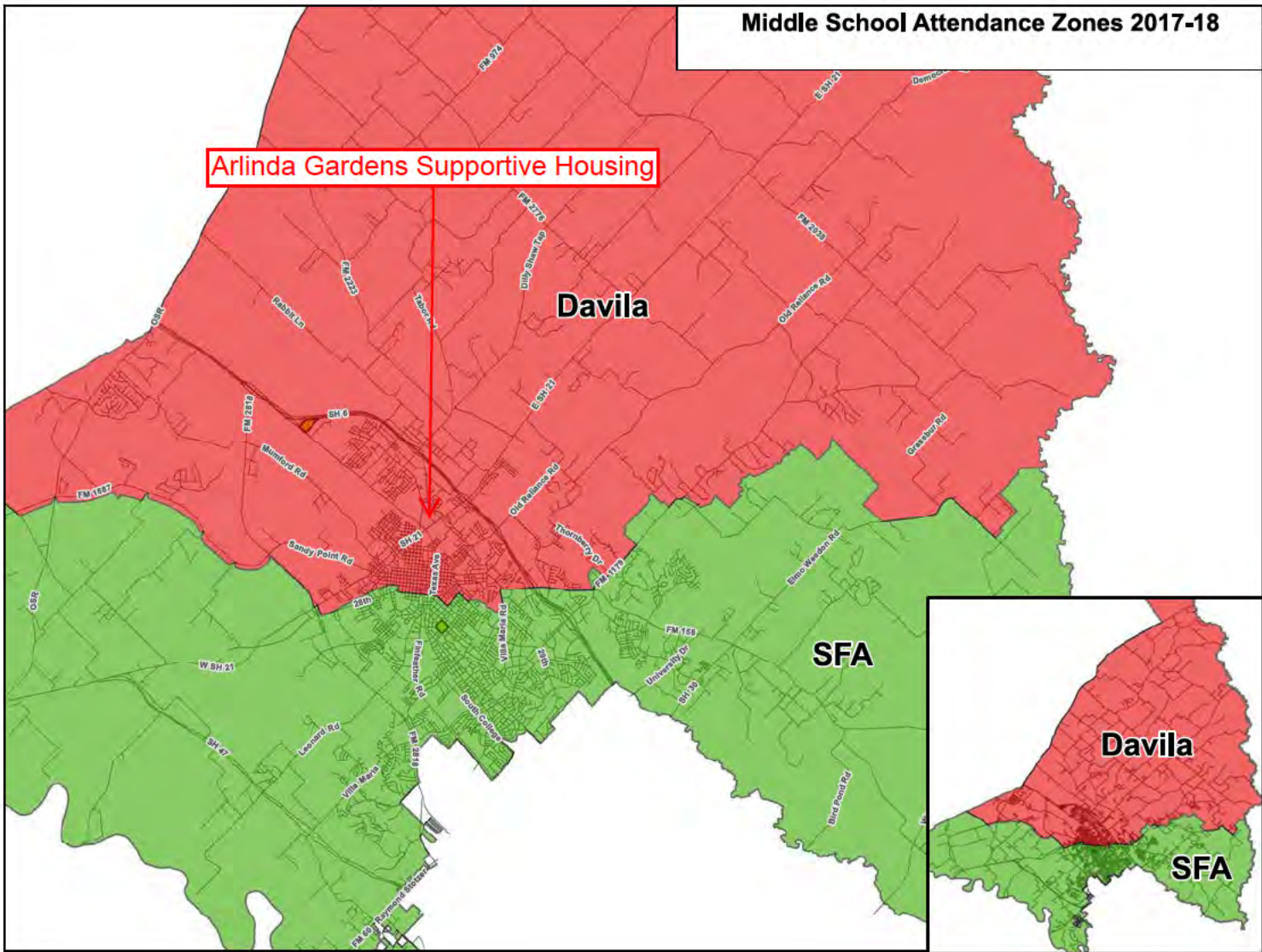

High School Attendance Zones 2017-18

Arlinda Gardens Supportive Housing

Rudder

Bryan

Rudder

Bryan

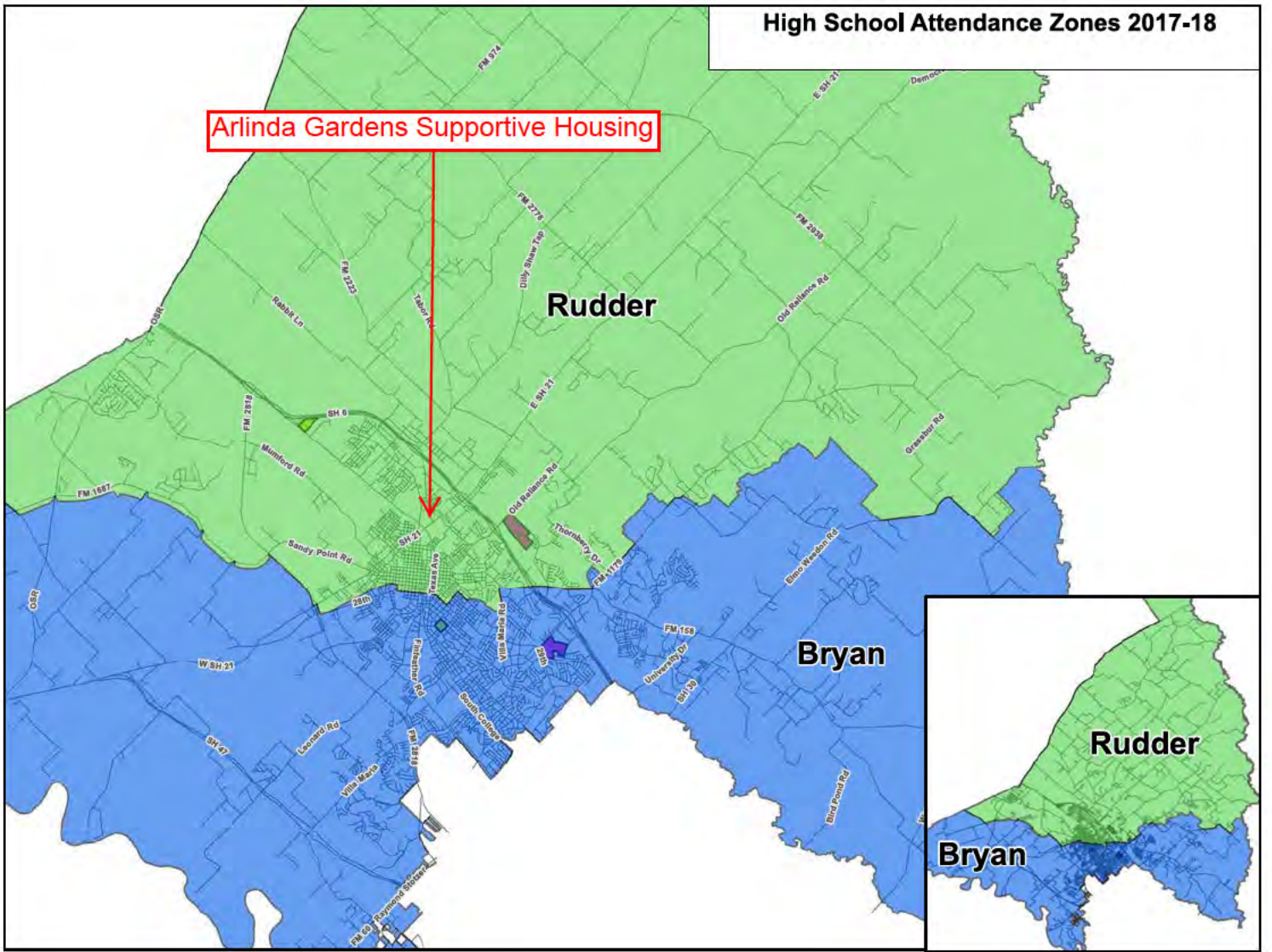

TEXAS EDUCATION AGENCY

2017 Accountability Summary

BONHAM EL (021902103) - BRYAN ISD

Accountability Rating

Met Standard

Met Standards on	Did Not Meet Standards on
<ul style="list-style-type: none"> - Student Achievement - Student Progress - Closing Performance Gaps - Postsecondary Readiness 	<ul style="list-style-type: none"> - NONE
In 2017, to receive a Met Standard or Met Alternative Standard rating, districts and campuses must meet targets on three indexes: Index 1 or Index 2 and Index 3 and Index 4.	

Distinction Designation

Academic Achievement in ELA/Reading	NO DISTINCTION EARNED
Academic Achievement in Mathematics	NO DISTINCTION EARNED
Academic Achievement in Science	NO DISTINCTION EARNED
Academic Achievement in Social Studies	NOT ELIGIBLE
Top 25 Percent Student Progress	NO DISTINCTION EARNED
Top 25 Percent Closing Performance Gaps	NO DISTINCTION EARNED
Postsecondary Readiness	NO DISTINCTION EARNED

Performance Index Report

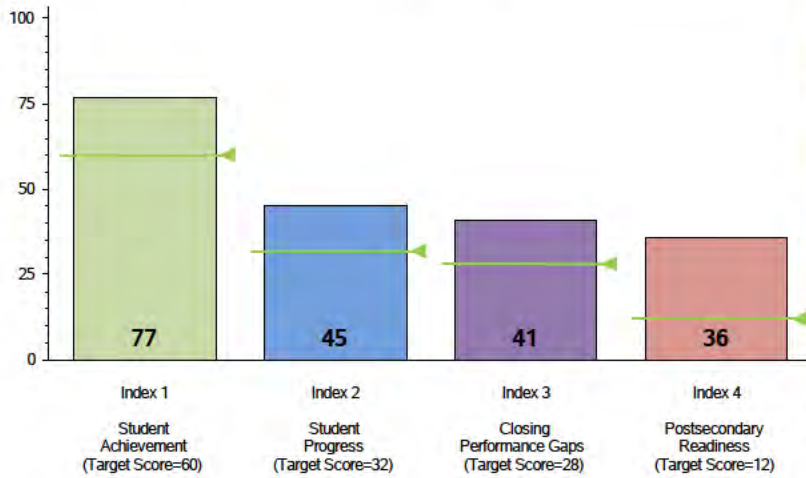

Campus Demographics

Campus Type	Elementary
Campus Size	808 Students
Grade Span	PK - 05
Percent Economically Disadvantaged	75.0
Percent English Language Learners	32.8
Mobility Rate	11.9
Percent Served by Special Education	6.2
Percent Enrolled in an Early College High School Program	0.0

Performance Index Summary

Index	Points Earned	Maximum Points	Index Score
1 - Student Achievement	774	1,009	77
2 - Student Progress	536	1,200	45
3 - Closing Performance Gaps	812	2,000	41
4 - Postsecondary Readiness			
STAAR Score	36.3		
Graduation Rate Score	N/A		
Graduation Plan Score	N/A		
Postsecondary Component Score	N/A		36

System Safeguards

Number and Percentage of Indicators Met

Performance Rates	18 out of 24 = 75%
Participation Rates	14 out of 14 = 100%
Graduation Rates	N/A
Total	32 out of 38 = 84%

For further information about this report, please see the Performance Reporting website at <https://rptsvr1.tea.texas.gov/perfreport/account/2017/index.html>

TEXAS EDUCATION AGENCY
2017 Accountability Summary
 ARTHUR L DAVILA MIDDLE (021902047) - BRYAN ISD

Accountability Rating

Met Standard

Met Standards on	Did Not Meet Standards on
<ul style="list-style-type: none"> - Student Achievement - Student Progress - Closing Performance Gaps - Postsecondary Readiness 	<ul style="list-style-type: none"> - NONE
In 2017, to receive a Met Standard or Met Alternative Standard rating, districts and campuses must meet targets on three indexes: Index 1 or Index 2 and Index 3 and Index 4.	

Distinction Designation

Academic Achievement in ELA/Reading	NO DISTINCTION EARNED
Academic Achievement in Mathematics	NO DISTINCTION EARNED
Academic Achievement in Science	NO DISTINCTION EARNED
Academic Achievement in Social Studies	NO DISTINCTION EARNED
Top 25 Percent Student Progress	NO DISTINCTION EARNED
Top 25 Percent Closing Performance Gaps	NO DISTINCTION EARNED
Postsecondary Readiness	NO DISTINCTION EARNED

Performance Index Report

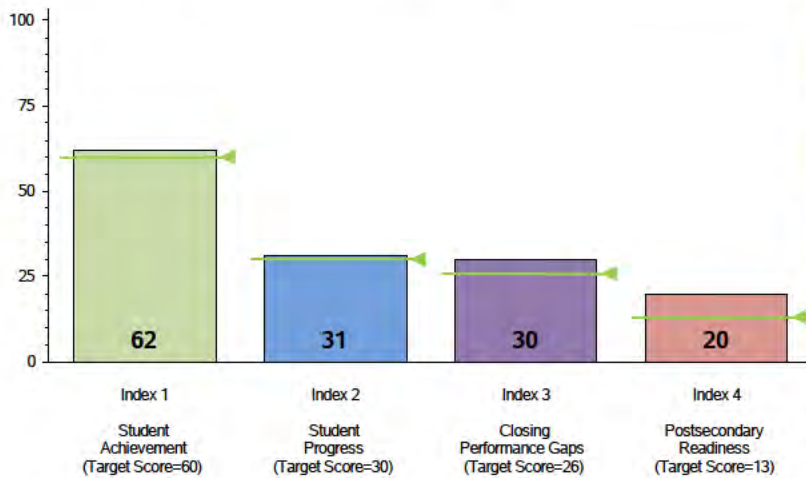

Campus Demographics

Campus Type	Middle School
Campus Size	661 Students
Grade Span	06 - 08
Percent Economically Disadvantaged	80.3
Percent English Language Learners	27.2
Mobility Rate	18.8
Percent Served by Special Education	15.0
Percent Enrolled in an Early College High School Program	0.0

Performance Index Summary

Index	Points Earned	Maximum Points	Index Score
1 - Student Achievement	1,119	1,812	62
2 - Student Progress	372	1,200	31
3 - Closing Performance Gaps	780	2,600	30
4 - Postsecondary Readiness			
STAAR Score	19.5		
Graduation Rate Score	N/A		
Graduation Plan Score	N/A		
Postsecondary Component Score	N/A		20

System Safeguards

Number and Percentage of Indicators Met

Performance Rates	14 out of 33 = 42%
Participation Rates	14 out of 14 = 100%
Graduation Rates	N/A
Total	28 out of 47 = 60%

For further information about this report, please see the Performance Reporting website at <https://rptsrv1.tea.texas.gov/perfreport/account/2017/index.html>

TEXAS EDUCATION AGENCY
2017 Accountability Summary
 JAMES EARL RUDDER H S (021902002) - BRYAN ISD

Accountability Rating

Met Standard

Met Standards on

- Student Progress
- Closing Performance Gaps
- Postsecondary Readiness

Did Not Meet Standards on

- Student Achievement

In 2017, to receive a Met Standard or Met Alternative Standard rating, districts and campuses must meet targets on three indexes: Index 1 or Index 2 and Index 3 and Index 4.

Distinction Designation



Academic Achievement in ELA/Reading

NO DISTINCTION EARNED

Academic Achievement in Mathematics

NO DISTINCTION EARNED

Academic Achievement in Science

NO DISTINCTION EARNED

Academic Achievement in Social Studies

DISTINCTION EARNED

Top 25 Percent Student Progress

NO DISTINCTION EARNED

Top 25 Percent Closing Performance Gaps

NO DISTINCTION EARNED

Postsecondary Readiness

NO DISTINCTION EARNED

Performance Index Report

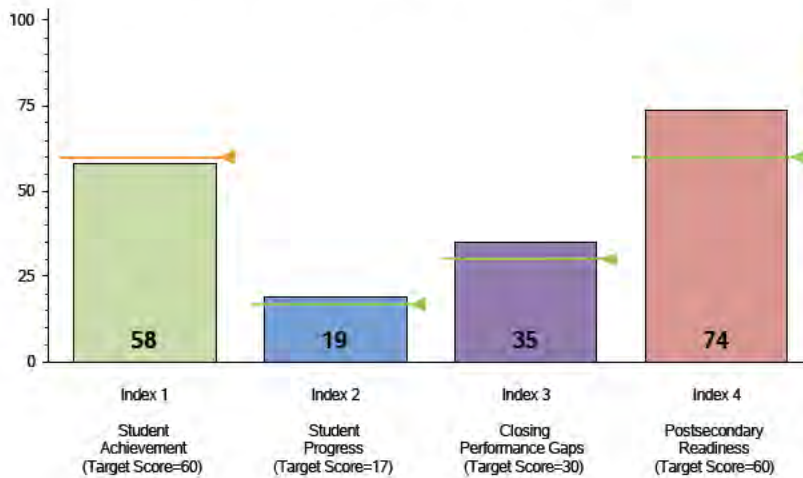

Campus Demographics

Campus Type	High School
Campus Size	1,627 Students
Grade Span	09 - 12
Percent Economically Disadvantaged	71.8
Percent English Language Learners	11.4
Mobility Rate	20.3
Percent Served by Special Education	9.0
Percent Enrolled in an Early College High School Program	0.0

Performance Index Summary

Index	Points Earned	Maximum Points	Index Score
1 - Student Achievement	1,624	2,792	58
2 - Student Progress	233	1,200	19
3 - Closing Performance Gaps	834	2,400	35
4 - Postsecondary Readiness			
STAAR Score	10.5		
Graduation Rate Score	23.0		
Graduation Plan Score	23.6		
Postsecondary Component Score	16.9		74

System Safeguards

Number and Percentage of Indicators Met

Performance Rates	13 out of 28 = 46%
Participation Rates	14 out of 14 = 100%
Graduation Rates	6 out of 6 = 100%
Total	33 out of 48 = 69%

For further information about this report, please see the Performance Reporting website at <https://rptsvr1.tea.texas.gov/perfreport/account/2017/index.html>

TEXAS EDUCATION AGENCY

2016 Accountability Summary

BONHAM EL (021902103) - BRYAN ISD

Accountability Rating

Met Standard

Met Standards on	Did Not Meet Standards on
<ul style="list-style-type: none"> - Student Achievement - Student Progress - Closing Performance Gaps - Postsecondary Readiness 	<ul style="list-style-type: none"> - NONE
In 2016, to receive a Met Standard or Met Alternative Standard rating, districts and campuses must meet targets on three indexes: Index 1 or Index 2 and Index 3 and Index 4.	

Distinction Designation

Academic Achievement in ELA/Reading	NO DISTINCTION EARNED
Academic Achievement in Mathematics	NO DISTINCTION EARNED
Academic Achievement in Science	NO DISTINCTION EARNED
Academic Achievement in Social Studies	NOT ELIGIBLE
Top 25 Percent Student Progress	NO DISTINCTION EARNED
Top 25 Percent Closing Performance Gaps	NO DISTINCTION EARNED
Postsecondary Readiness	NO DISTINCTION EARNED

Performance Index Report

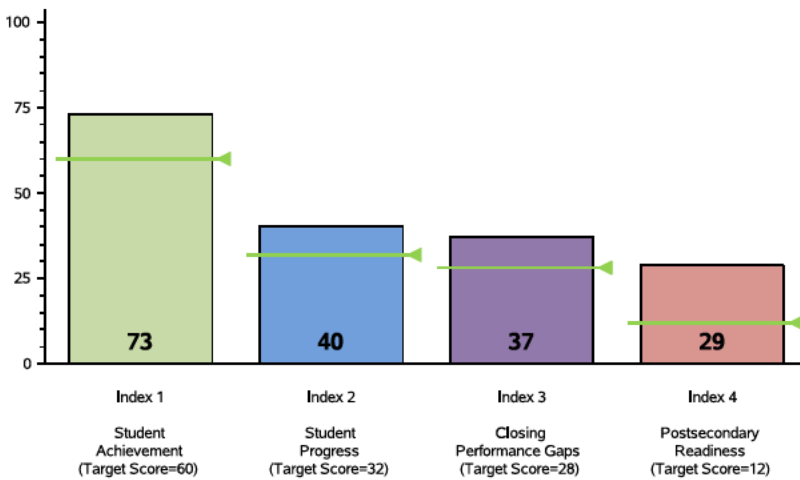

Campus Demographics

Campus Type	Elementary
Campus Size	834 Students
Grade Span	PK - 05
Percent Economically Disadvantaged	71.7
Percent English Language Learners	31.4
Mobility Rate	11.6

Performance Index Summary

Index	Points Earned	Maximum Points	Index Score
1 - Student Achievement	752	1,025	73
2 - Student Progress	483	1,200	40
3 - Closing Performance Gaps	742	2,000	37
4 - Postsecondary Readiness			
STAAR Score	29.3		
Graduation Rate Score	N/A		
Graduation Plan Score	N/A		
Postsecondary Component Score	N/A		29

System Safeguards

Number and Percentage of Indicators Met	
Performance Rates	20 out of 24 = 83%
Participation Rates	14 out of 14 = 100%
Graduation Rates	N/A
Total	34 out of 38 = 89%

For further information about this report, please see the Performance Reporting Division website at <https://rptsrv1.tea.texas.gov/perfreport/account/2016/index.html>

TEXAS EDUCATION AGENCY
2016 Accountability Summary
 ARTHUR L DAVILA MIDDLE (021902047) - BRYAN ISD

Accountability Rating

Met Standard

Met Standards on	Did Not Meet Standards on
- Student Achievement - Student Progress - Closing Performance Gaps - Postsecondary Readiness	- NONE
In 2016, to receive a Met Standard or Met Alternative Standard rating, districts and campuses must meet targets on three indexes: Index 1 or Index 2 and Index 3 and Index 4.	

Distinction Designation

Academic Achievement in ELA/Reading	NO DISTINCTION EARNED
Academic Achievement in Mathematics	NO DISTINCTION EARNED
Academic Achievement in Science	NO DISTINCTION EARNED
Academic Achievement in Social Studies	NO DISTINCTION EARNED
Top 25 Percent Student Progress	NO DISTINCTION EARNED
Top 25 Percent Closing Performance Gaps	NO DISTINCTION EARNED
Postsecondary Readiness	NO DISTINCTION EARNED

Performance Index Report

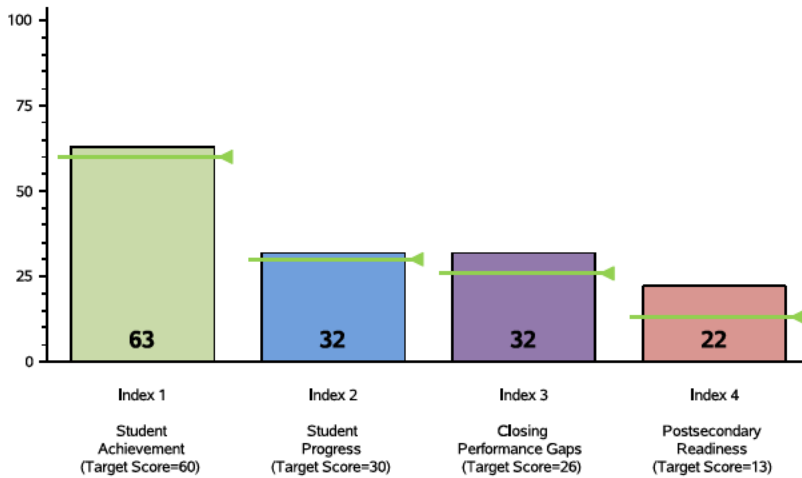

Campus Demographics

Campus Type	Middle School
Campus Size	613 Students
Grade Span	06 - 08
Percent Economically Disadvantaged	80.8
Percent English Language Learners	22.8
Mobility Rate	20.5

Performance Index Summary

Index	Points Earned	Maximum Points	Index Score
1 - Student Achievement	1,080	1,727	63
2 - Student Progress	387	1,200	32
3 - Closing Performance Gaps	897	2,800	32
4 - Postsecondary Readiness			
STAAR Score	21.8		
Graduation Rate Score	N/A		
Graduation Plan Score	N/A		
Postsecondary Component Score	N/A		22

System Safeguards

Number and Percentage of Indicators Met

Performance Rates	18 out of 31 = 58%
Participation Rates	14 out of 14 = 100%
Graduation Rates	N/A
Total	32 out of 45 = 71%

For further information about this report, please see the Performance Reporting Division website at <https://rptsrv1.tea.texas.gov/perfreport/account/2016/index.html>

TEXAS EDUCATION AGENCY
2016 Accountability Summary
 JAMES EARL RUDDER H S (021902002) - BRYAN ISD

Accountability Rating

Improvement Required

Met Standards on - Closing Performance Gaps - Postsecondary Readiness	Did Not Meet Standards on - Student Achievement - Student Progress
In 2016, to receive a Met Standard or Met Alternative Standard rating, districts and campuses must meet targets on three indexes: Index 1 or Index 2 and Index 3 and Index 4.	

Distinction Designation

Academic Achievement in ELA/Reading	NO DISTINCTION EARNED
Academic Achievement in Mathematics	NO DISTINCTION EARNED
Academic Achievement in Science	NO DISTINCTION EARNED
Academic Achievement in Social Studies	NO DISTINCTION EARNED
Top 25 Percent Student Progress	NO DISTINCTION EARNED
Top 25 Percent Closing Performance Gaps	NO DISTINCTION EARNED
Postsecondary Readiness	NO DISTINCTION EARNED

Performance Index Report

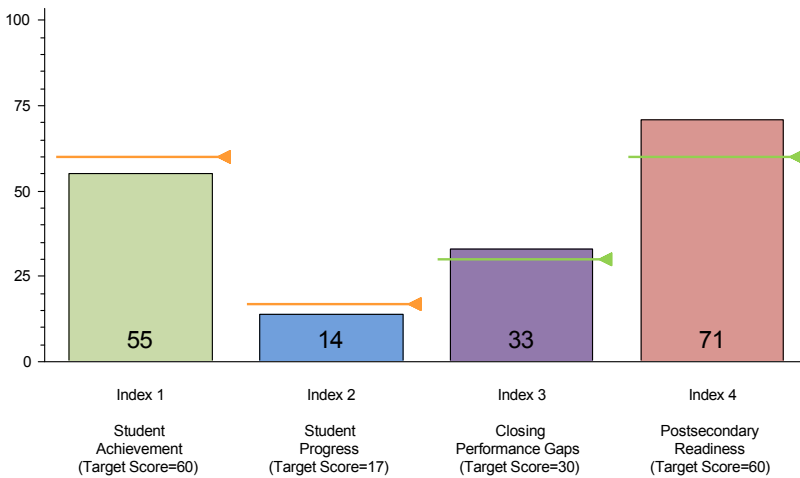

Campus Demographics

Campus Type	High School
Campus Size	1,646 Students
Grade Span	09 - 12
Percent Economically Disadvantaged	69.6
Percent English Language Learners	8.5
Mobility Rate	20.8

Performance Index Summary

Index	Points Earned	Maximum Points	Index Score
1 - Student Achievement	1,578	2,844	55
2 - Student Progress	166	1,200	14
3 - Closing Performance Gaps	797	2,400	33
4 - Postsecondary Readiness			
STAAR Score	9.0		
Graduation Rate Score	22.8		
Graduation Plan Score	23.6		
Postsecondary Component Score	15.3		71

System Safeguards

Number and Percentage of Indicators Met	
Performance Rates	14 out of 28 = 50%
Participation Rates	14 out of 14 = 100%
Graduation Rates	5 out of 5 = 100%
Total	33 out of 47 = 70%

For further information about this report, please see the Performance Reporting Division website at <https://rptsvr1.tea.texas.gov/perfreport/account/2016/index.html>

TEXAS EDUCATION AGENCY
2015 Accountability Summary
 BONHAM EL (021902103) - BRYAN ISD

Accountability Rating

Met Standard

Met Standards on	Did Not Meet Standards on
- Student Achievement	- NONE
- Student Progress	
- Closing Performance Gaps	
- Postsecondary Readiness	
In 2015, to receive a Met Standard or Met Alternative Standard rating, districts and campuses must meet targets on three indexes: Index 1 or Index 2 and Index 3 and Index 4.	

Distinction Designation

Academic Achievement in Reading/ELA	NO DISTINCTION EARNED
Academic Achievement in Mathematics	NOT ELIGIBLE
Academic Achievement in Science	NO DISTINCTION EARNED
Academic Achievement in Social Studies	NOT ELIGIBLE
Top 25 Percent Student Progress	NO DISTINCTION EARNED
Top 25 Percent Closing Performance Gaps	NO DISTINCTION EARNED
Postsecondary Readiness	NO DISTINCTION EARNED

Performance Index Report

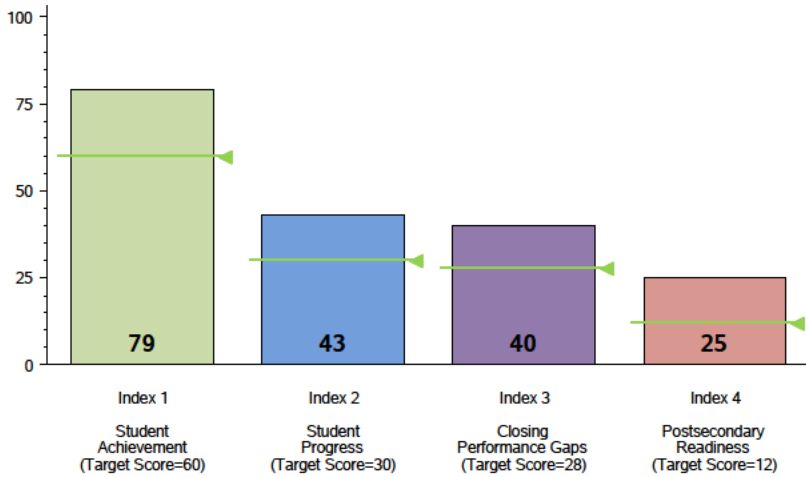

Campus Demographics

Campus Type	Elementary
Campus Size	844 Students
Grade Span	PK - 05
Percent Economically Disadvantaged	73.1
Percent English Language Learners	30.9
Mobility Rate	10.7

Performance Index Summary

Index	Points Earned	Maximum Points	Index Score
1 - Student Achievement	484	615	79
2 - Student Progress	429	1,000	43
3 - Closing Performance Gaps	558	1,400	40
4 - Postsecondary Readiness			
STAAR Score	24.5		
Graduation Rate Score	N/A		
Graduation Plan Score	N/A		
Postsecondary Component Score	N/A		25

State System Safeguards

Number and Percent of Indicators Met

Performance Rates	15 out of 16 = 94%
Participation Rates	6 out of 6 = 100%
Graduation Rates	N/A
Total	21 out of 22 = 95%

For further information about this report, please see the Performance Reporting Division website at <http://ritter.tea.state.tx.us/perfreport/account/2015/index.html>

TEXAS EDUCATION AGENCY
2015 Accountability Summary
 ARTHUR L DAVILA MIDDLE (021902047) - BRYAN ISD

Accountability Rating

Met Standard

Met Standards on - Student Achievement - Student Progress - Closing Performance Gaps - Postsecondary Readiness	Did Not Meet Standards on - NONE
In 2015, to receive a Met Standard or Met Alternative Standard rating, districts and campuses must meet targets on three indexes: Index 1 or Index 2 and Index 3 and Index 4.	

Distinction Designation

Academic Achievement in Reading/ELA NO DISTINCTION EARNED
Academic Achievement in Mathematics NO DISTINCTION EARNED
Academic Achievement in Science NO DISTINCTION EARNED
Academic Achievement in Social Studies NO DISTINCTION EARNED
Top 25 Percent Student Progress NO DISTINCTION EARNED
Top 25 Percent Closing Performance Gaps NO DISTINCTION EARNED
Postsecondary Readiness NO DISTINCTION EARNED

Performance Index Report

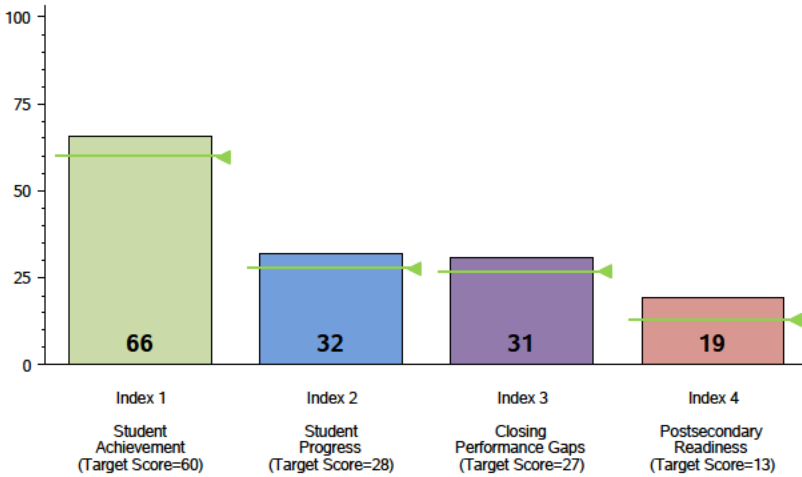

Campus Demographics

Campus Type	Middle School
Campus Size	651 Students
Grade Span	06 - 08
Percent Economically Disadvantaged	77.6
Percent English Language Learners	20.3
Mobility Rate	18.3

Performance Index Summary

Index	Points Earned	Maximum Points	Index Score
1 - Student Achievement	779	1,187	66
2 - Student Progress	322	1,000	32
3 - Closing Performance Gaps	746	2,400	31
4 - Postsecondary Readiness			
STAAR Score	18.8		
Graduation Rate Score	N/A		
Graduation Plan Score	N/A		
Postsecondary Component Score	N/A		19

State System Safeguards

Number and Percent of Indicators Met	
Performance Rates	14 out of 25 = 56%
Participation Rates	8 out of 8 = 100%
Graduation Rates	N/A
Total	22 out of 33 = 67%

For further information about this report, please see the Performance Reporting Division website at <http://ritter.tea.state.tx.us/perfreport/account/2015/index.html>

TEXAS EDUCATION AGENCY
2015 Accountability Summary
 JAMES EARL RUDDER H S (021902002) - BRYAN ISD

Accountability Rating

Met Standard

Met Standards on

- Student Achievement
- Closing Performance Gaps
- Postsecondary Readiness

Did Not Meet Standards on

- Student Progress

In 2015, to receive a Met Standard or Met Alternative Standard rating, districts and campuses must meet targets on three indexes: Index 1 or Index 2 and Index 3 and Index 4.

Distinction Designation



Academic Achievement in Reading/ELA

NO DISTINCTION EARNED

Academic Achievement in Mathematics

NO DISTINCTION EARNED

Academic Achievement in Science

DISTINCTION EARNED

Academic Achievement in Social Studies

DISTINCTION EARNED

Top 25 Percent Student Progress

NO DISTINCTION EARNED

Top 25 Percent Closing Performance Gaps

NO DISTINCTION EARNED

Postsecondary Readiness

NO DISTINCTION EARNED

Performance Index Report

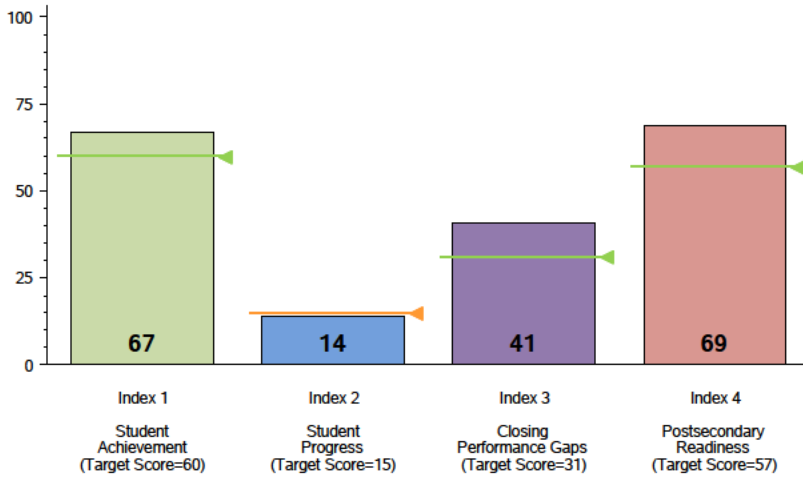

Campus Demographics

Campus Type	High School
Campus Size	1,559 Students
Grade Span	09 - 12
Percent Economically Disadvantaged	64.8
Percent English Language Learners	6.2
Mobility Rate	21.7

Performance Index Summary

Index	Points Earned	Maximum Points	Index Score
1 - Student Achievement	1,511	2,241	67
2 - Student Progress	135	1,000	14
3 - Closing Performance Gaps	972	2,400	41
4 - Postsecondary Readiness			
STAAR Score	10.5		
Graduation Rate Score	20.9		
Graduation Plan Score	22.8		
Postsecondary Component Score	15.0		69

State System Safeguards

Number and Percent of Indicators Met

Performance Rates	16 out of 24 = 67%
Participation Rates	13 out of 13 = 100%
Graduation Rates	6 out of 6 = 100%
Total	35 out of 43 = 81%

For further information about this report, please see the Performance Reporting Division website at <http://ritter.tea.state.tx.us/perfreport/account/2015/index.html>



**TEXAS DEPARTMENT OF
HOUSING & COMMUNITY AFFAIRS**
Building Homes. Strengthening Communities.

TAB 9

Site Information Form (Part II)

Site Information Form Part II

1. §11.9(c)(4) - Opportunity Index (Competitive HTC and Direct Loan Applications Only)

Development Site is located entirely within a census tract that has a poverty rate that is less than 20% **or** that is less than the median poverty rate for the region, whichever is higher.

AND

The census tract has a median household income rate in the two highest quartiles within the region.

OR

The census tract has a median household income in the third quartile within the region, **and** is contiguous to a census tract in the first or second quartile without physical barriers such as highways or rivers between, **and** the Development Site is no more than 2 miles from the boundary between the census tracts. A map showing the Development Site, location of the border, scale showing distance, and other applicable evidence is included.

Contiguous Census Tract #

Contiguous Tract Quartile

Development is Urban and Development Site is within the required radius of eligible amenities and/or services, pursuant to §11.9(c)(4)(B)(i) of the QAP. A map showing the Development Site, scale showing radius, location of the amenities, and evidence that the amenity meets all requirements of the rule, as applicable, is included.

full service grocery store (1 mile)

health-related facility (3 miles)

licensed center serving children (2 miles)

pharmacy (1 mile)

university or community college (5 miles)

indoor recreation facility available to public (1 mile)

outdoor recreation facility available to public (1 mile)

community, civic or service organization (1 mile)

Development is Rural or USDA and Development Site is within the required distance of eligible amenities and/or services pursuant to §11.9(c)(4)(B)(ii) of the QAP. A map showing the Development Site, scale showing radius, location of the amenities, and evidence that the amenity meets all requirements of the rule, as applicable, is included.

No members of the Applicant or Affiliates had an ownership position in a selected amenity or served on the board or staff of a nonprofit that owned or managed a selected amenity within the year preceding the Pre-Application Final Delivery Date.

Application is seeking points for Opportunity Index.

Total Points Claimed:



7

If necessary, provide a brief summary of how the Development Site is justifying the points selected:

2. **§11.9(c)(5) - Underserved Area (Competitive HTC and Direct Loan Applications Only)**

Applications may qualify for up to five (5) points for proposed Developments located in one of the following areas:

- Wholly or partially within a Colonia (Note: Not eligible if application qualifies for Opportunity Index points);
- Entirely within the boundaries of an Economically Distressed Area (Note: Not eligible if application qualifies for Opportunity Index points);
- Entirely within a census tract that does not have a Development that was awarded less than 30 years ago according to the Department's property inventory tab of the Site Demographic Characteristics Report;
- Entirely within a census tract that does not have a Development that was awarded less than 15 years ago according to the Department's property inventory tab of the Site Demographic Characteristics Report;
- Entirely within a census tract whose boundaries are wholly within an incorporated area and the census tract itself and all of its contiguous census tracts do not have a Development that was awarded less than 15 years ago according to the Department's property inventory tab of the Site Demographic Characteristics Report. This item will apply in Places with a population of 150,000 or more, and will not apply in the At-Risk Set-Aside.

Contiguous Census Tract #	<input type="text"/>	Contiguous Census Tract #	<input type="text"/>
Contiguous Census Tract #	<input type="text"/>	Contiguous Census Tract #	<input type="text"/>
Contiguous Census Tract #	<input type="text"/>	Contiguous Census Tract #	<input type="text"/>

Application is seeking points for Underserved Area. Total Points Claimed:

3. **§11.9(c)(7) - Proximity to the Urban Core (Competitive HTC Applications Only)**

- Development Site is located in a Place with a population over 200,000 and is *not* in the At-Risk Set-Aside.
- AND
- Population of Place is 200,000-499,999 and Development is located w/in 2 miles of the main municipal government administration building. OR
- Population of Place is 500,000 or more and Development is located w/in 4 miles of the main municipal government administration building.

Application is seeking points for Proximity to the Urban Core. Total Points Claimed:

4. **§11.9(d)(7) - Concerted Revitalization Plan (Competitive HTC Applications Only)**

Region:

- Development is in an Urban Area.
- Application includes a copy of the plan or a link to the online plan and a description of where specific information required can be found in the plan.
- Plan is current at the time of Application and officially continues for a minimum of three years thereafter.
- Plan has been adopted by the municipality or county and resolution or certification is attached.
- Letter from appropriate local official, target area map, and supporting documentation are provided.
- Development is explicitly identified by the municipality or county as contributing more than any other to the concerted revitalization efforts of the municipality, county or distinct district; resolution stating such is provided.
- Evidence of sufficient, documented and committed funding to accomplish the plan's purposes on its established timetable is provided.
- No points were claimed for Opportunity Index, but location would qualify for at least 4 points under §11.9(c)(4)(B):

<input type="text"/>	<input type="text"/>
<input type="text"/>	<input type="text"/>

- A map showing the Development Site, scale showing radius, location of the amenities, and evidence that the amenity meets all requirements of the rule, as applicable, is included.
- No members of the Applicant or Affiliates had an ownership position in a selected amenity or served on the board or staff of a nonprofit that owned or managed a selected amenity within the year preceding the Pre-Application Final Delivery Date.

OR

Development is in a Rural Area. Rehabilitation Demolition/Reconstruction

Development has been leased at 85% or more for the six months preceding Application by low income households (excluding unlivable units identified in CNA);

AND

Development was constructed 25 or more years prior to Application submission as either public housing or as affordable housing with support from USDA, HUD, HOME, or CDBG;

AND, if applicable,

demolition and relocation of units has been determined locally to be necessary to comply with Affirmatively Furthering Fair Housing Rule or to create acceptable distance from Undesirable Neighborhood Characteristics.

Development is explicitly identified in a resolution by the municipality or county as contributing more than any other to the concerted revitalization efforts of the municipality or county; letter from Governing Body stating such is provided behind this tab.

No points were claimed for Opportunity Index, but location would qualify for at least 4 points under §11.9(c)(4)(B):

A map showing the Development Site, scale showing radius, location of the amenities, and evidence that the amenity meets all requirements of the rule, as applicable, is included behind this tab.

No members of the Applicant or Affiliates had an ownership position in a selected amenity or served on the board or staff of a nonprofit that owned or managed a selected amenity within the year preceding the Pre-Application Final Delivery Date.

Application is seeking points for Concerted Revitalization.

Total Points Claimed:



5. §11.9(d)(3) - Declared Disaster Area Scoring (Competitive HTC Applications ONLY)

Development is located in an area that qualifies as a Declared Disaster Area as defined in §11.9(d)(3).

Application is seeking points for Declared Disaster Area.

Total Points Claimed:

6. §11.9(c)(8) - Readiness to Proceed in Disaster Impacted Counties (Competitive HTC Applications ONLY)

Application meets all of the following requirements:

Application is for a proposed Development located in a county declared by FEMA to be eligible for individual assistance within the year preceding the Full Application Delivery Date.

Application includes evidence that the Applicant will close all financing on or before October 31, 2018.

Application includes evidence that the Applicant will fully execute the construction contract on or before October 31, 2018.

Application includes evidence that appropriate zoning will be in place at award.

Application includes a DETAILED narrative description of each piece of evidence provided and how that evidence proves that the Applicant will close all financing and fully execute the construction contract on or before October 31, 2018.

Application is seeking points for Readiness to Proceed.

Total Points Claimed:















**TEXAS DEPARTMENT OF
HOUSING & COMMUNITY AFFAIRS**
Building Homes. Strengthening Communities.

TAB 10



Supporting Documentation for the Information (Part II)

Supporting Documentation for the Site Information Form Part II

- Opportunity Index (Competitive HTC and Direct Loan Only)** 
- Map with Development Site boundaries indicated, relative to census tract boundaries 
- Map with Development Site boundaries indicated, relative to census tract boundaries; and contiguous census tract with evidence of no physical barriers between the tracts 
- Map(s) of Community Assets with Development, radius, and each asset labeled 
- Distances are measured from the nearest boundary of the Development Site to the nearest boundary of the property or easement containing the facility, unless otherwise noted. All measurements include ingress/egress and any easements
- For each amenity, supporting documentation to evidence how the amenity meets each requirement for the amenity
- Print-out from DFPS website confirming daycare licensed to serve relevant age groups
(http://www.dfps.state.tx.us/Child_Care/Search_Texas_Child_Care/ppFacilitySearchDayCare.asp)
- Crime rate information for census tract from Neighborhood Scout or local data source dated after October 1, 2017, including the computation used to determine the crime rate
(<https://www.neighborhoodscout.com>)
- Print-out from THECB website confirming accreditation of university or community college
<http://www.txhighereddata.org/Interactive/Institutions.cfm>
- Evidence of regular and recurring substantive services provided by community, civic or service organization, as applicable
- Evidence amenity is operational or has started site work (for instance: website postings, news paper ads, etc.); evidence of costs or membership fees, age restrictions, as applicable
- Evidence of Underserved Area (Competitive HTC and Direct Loan Only)**
- For Colonia: 
- Evidence from Attorney General of Colonia boundaries; *and*
<https://www.texasattorneygeneral.gov/cpd/colonias>
- Letter from the appropriate local government official or other evidence that the colonia lacks infrastructure and the Development will enable the current dwellings to connect to such infrastructure; *and*
- Map showing development site boundaries, relative to Colonia boundaries, and distance from Rio Grande river border. 
- For Economically Distressed Areas:
<http://www.twdb.texas.gov/financial/programs/EDAP/index.asp>
- A letter or correspondence from Texas Water Development Board indicating the boundaries of the EDA; *and*
- Map showing development site boundaries, relative to EDA boundaries. 
- For other items:
Development must be awarded 2002 or earlier for 15-year threshold and 1987 or earlier for 30-year threshold.
The Site Demographic Characteristics Report is posted on the Department's website at
<http://www.tdhca.state.tx.us/multifamily/apply-for-funds.htm>
- Map with Development Site boundaries indicated, relative to census tract boundaries 
- Map with census tract boundaries indicated, relative to boundaries of incorporated area, if applicable 
- Map with all contiguous census tracts, if applicable 
- Proximity to Urban Core (Competitive HTC Only)**
- Map with the appropriate radius, City Hall location, and evidence of meetings regularly scheduled for City Council, City Commission, or similar governing body. 

n/a Concerted Revitalization Plan (Competitive HTC Only)

Urban:

- n/a Copy of the plan, or link to electronic copy. Plan must document that 11.9(d)(7)(A)(i)(I-V) are met. 
- n/a Map of target area(s) with location of Development Site clearly identified. 
- n/a Resolution adopting the Concerted Revitalization Plan or resolution of delegation and other documentation.
- n/a Resolution identifying Development as contributing more than any other to revitalization effort
- n/a Letter from appropriate local official providing documentation of measurable improvements.
- n/a Evidence of committed funding
- n/a For each amenity, supporting documentation to evidence that the amenity meets each Opportunity Index requirement for the amenity

Rural:

- n/a Current rent roll
- n/a Evidence Development constructed 25 or more years prior to application (1992 or earlier) 
- n/a Evidence Development is public housing or affordable housing supported by USDA, HUD, HOME or CDBG
- Evidence demolition and relocation of units has been determined locally to be necessary to comply with Affirmatively Furthering Fair Housing Rule or to create acceptable distance from Undesirable Neighborhood Characteristics, if applicable.
- n/a Resolution from appropriate Governing Body describing concerted revitalization effort and identifying Development as contributing more than any other to such effort.
- n/a For each amenity, supporting documentation to evidence that the amenity meets each Opportunity Index requirement for the amenity

Declared Disaster Area:

- x The county in which the Development Site is located is listed on the 2018 List of Declared Disaster Areas (no further documentation is required).
The List of Declared Disaster Areas is posted on the Department's website at <http://www.tdhca.state.tx.us/multifamily/apply-for-funds.htm>
- x Applicant believes the county in which the Development Site is located was omitted from the list and should be listed. Application includes evidence that the Development Site is located in an area declared to be a disaster area under Tex. Gov't Code §418.014 at the time of early Application submission (January 26, 2018), at the Full Application Delivery Date, or at any time within the two-year period preceding the Full Application Delivery Date (as of March 1, 2016).

Readiness to Proceed

- x The county in which the Development Site is located is listed on the 2018 List of Declared Disaster Areas eligible for points under 10 TAC §11.9(c)(8) (no further documentation is required).
- x Evidence that the Applicant meets the requirements for Readiness to Proceed. Pursuant to 10 TAC 11.9(c)(8), the Application must include evidence that appropriate zoning will be in place at award (July 26, 2018).
- x Application includes evidence that appropriate zoning will be in place at award. 

Further, the Application must include evidence that the Applicant will close all financing and fully execute the construction contract on or before the last business day of October 2018. Examples of the kinds of documentation that may be used to evidence those milestones are listed below. Applicants may select any of these items, or use the "Other" selections to describe the evidence presented.

Each piece of evidence provided must be accompanied by a detailed narrative describing how that piece of evidence will allow the Applicant to meet the requirements. If evidence is not included behind this tab, use the space to describe where in the Application the evidence can be found. Evidence may include, but is not limited to:

- Loan or equity commitments with evidence of completed due diligence

- Confirmation from lender that non-refundable application and/or due diligence fee has been paid to lender and/or equity provider

Amenity Map For Points - 1 Mile

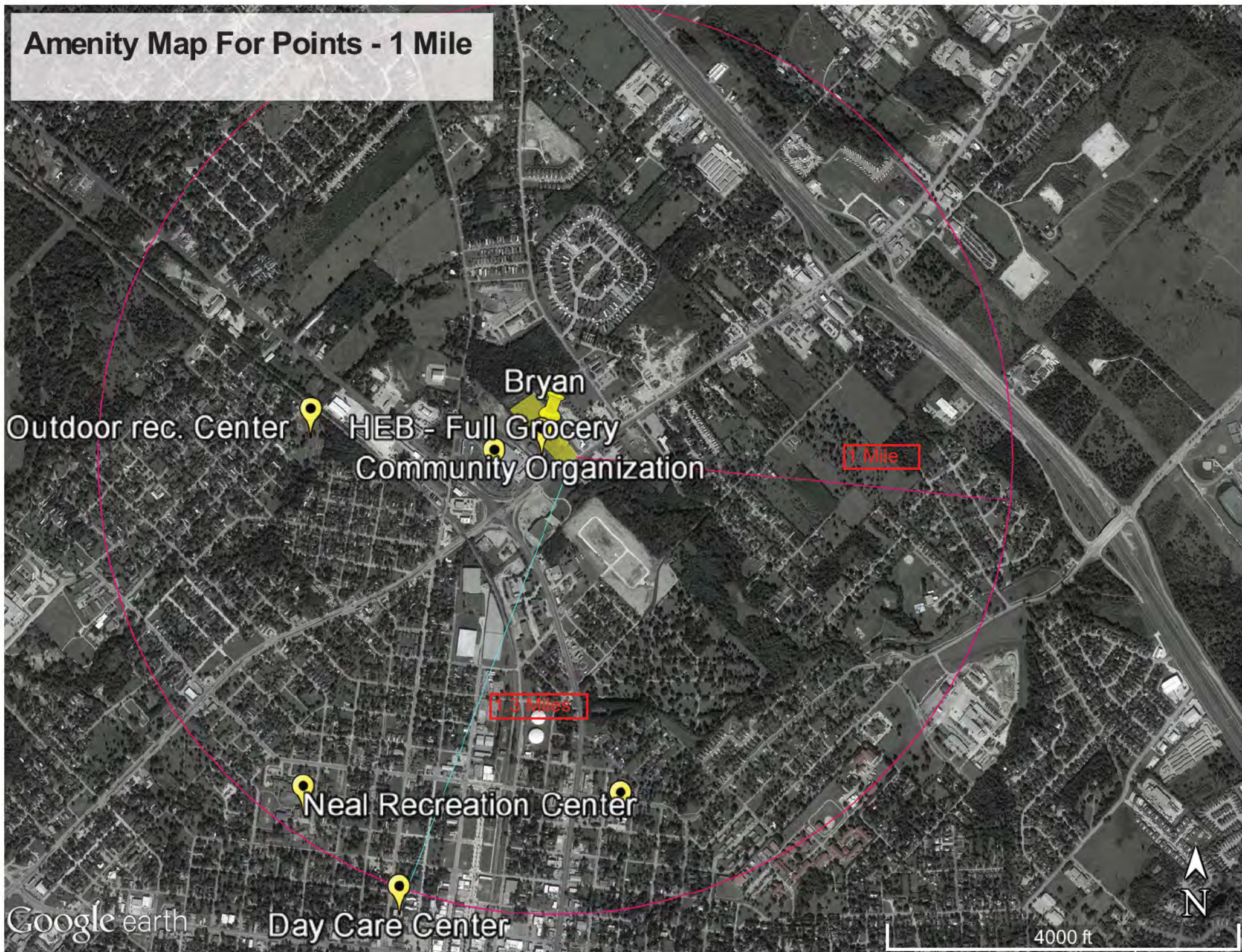

Amenity Map - 1 Miles

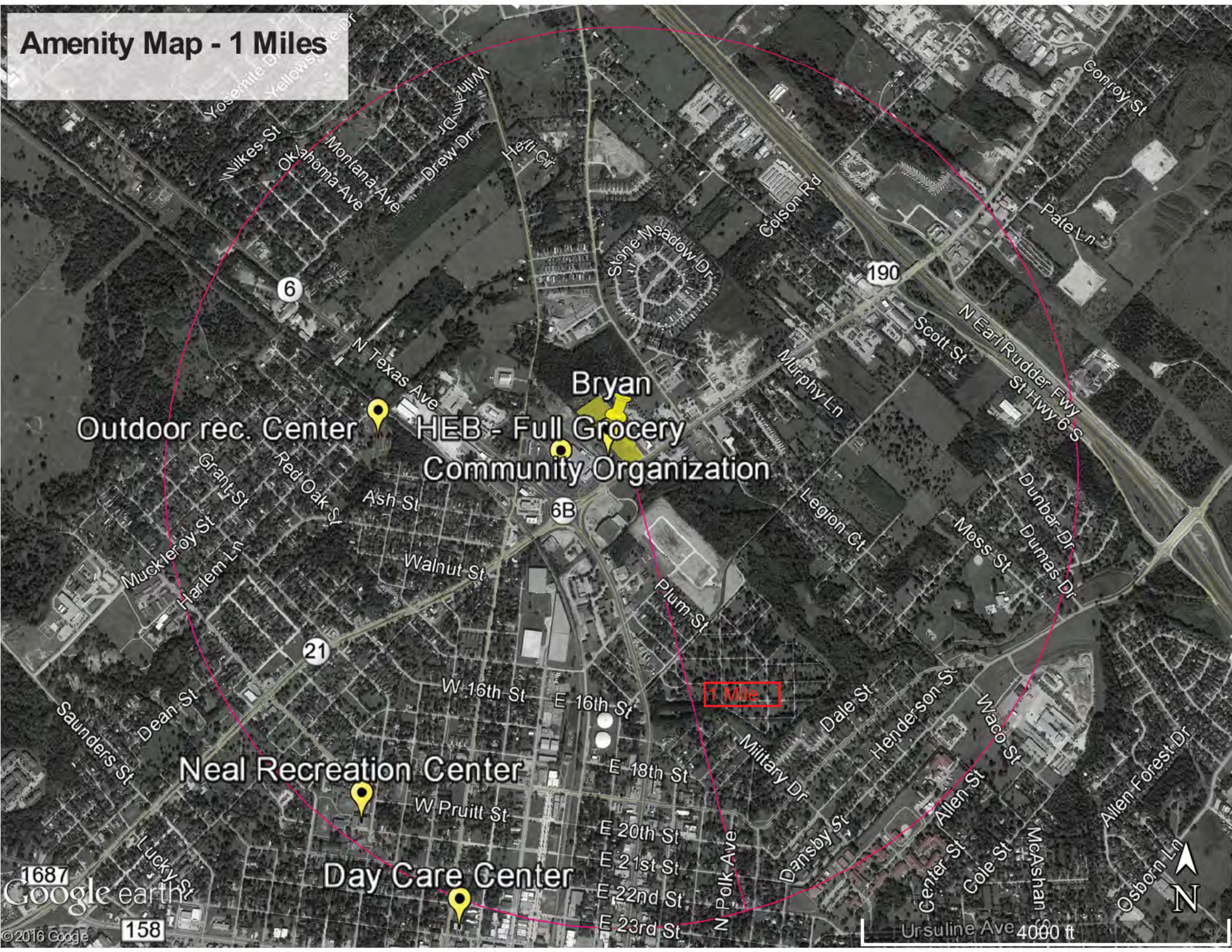

Outdoor rec. Center

HEB - Full Grocery
Community Organization

Neal Recreation Center

Day Care Center

Bryan

1 Mile

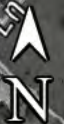

1687
Google earth

© 2016 Google 158

Ursuline Ave 4000 ft

Amenity Map - 3 Miles

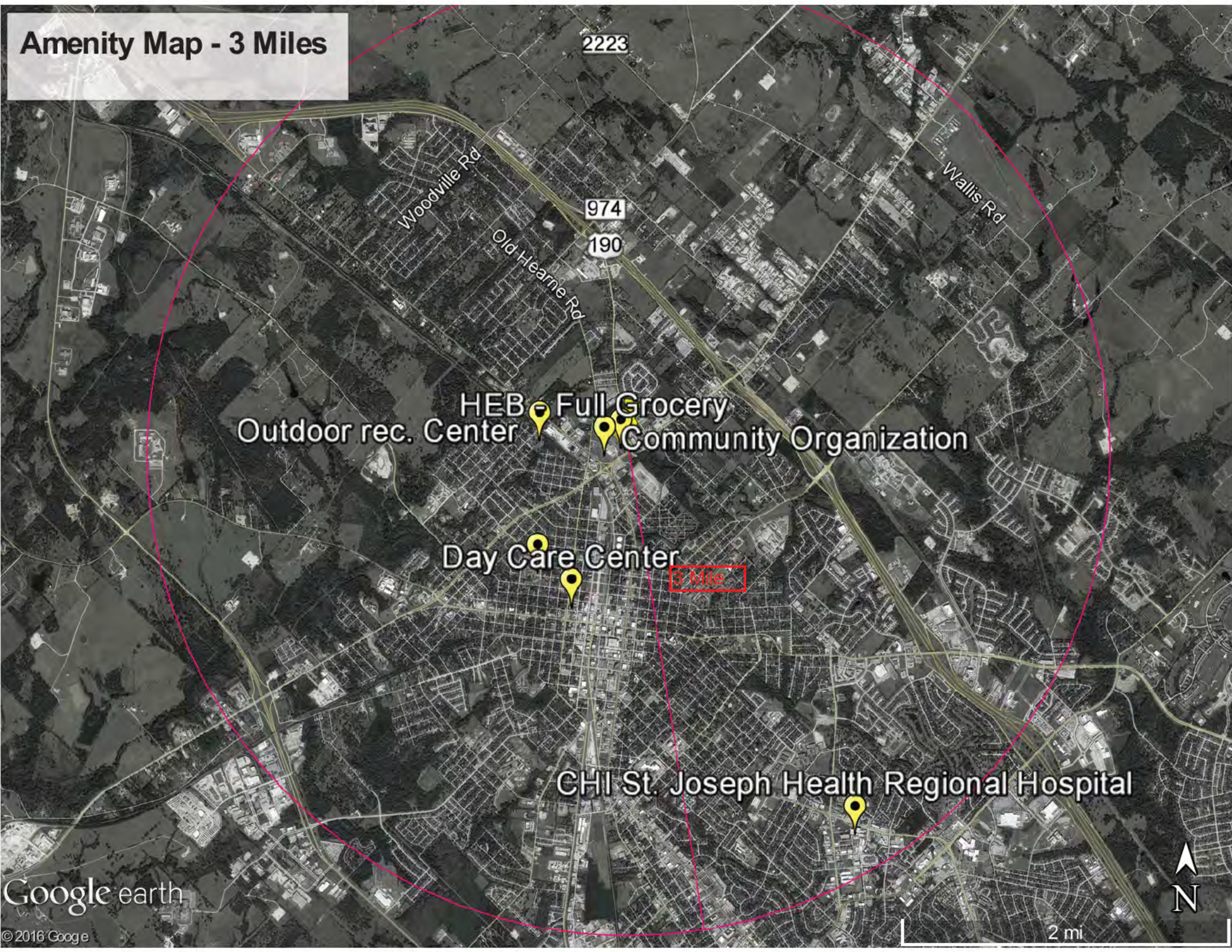

2223

Woodville Rd

974

Wallis Rd

190

Old Hearne Rd

HEB Full Grocery
Outdoor rec. Center Community Organization

Day Care Center

3 Miles

CHI St. Joseph Health Regional Hospital



Amenity Map - 5 Miles

- HEB - Full Grocery
- Outdoor rec. Center
- Community Organization
- Day Care Center
- Neal Recreation Center
- CHI St. Joseph Health Regional Hospital
- Public University
- Public University

Highway 21 W

21

6

5 Mile

4 mi



Amenity Map - 1, 2 & 5 Miles

HEB - Full Grocery
Outdoor rec. Center
Community Organization
Day Care Center
Neal Recreation Center
CHI St. Joseph Health Regional Hospital
Public University
Public University

N Texas Ave
(21)

1 Mile
5 Mile
5 Mile



Brazos Valley Community Church - Church

2002 State Hwy 21 E

Bryan, TX 77803

(979) 778-7680

bvccog.org

H-E-B Grocery & Pharmacy — Pharmacy & Full Grocery

1609 N Texas Ave

Bryan, TX 77803

(979) 778-2074

Opens at 9:00 AM

heb.com

Scurry Park — Park Outdoor recreation

1501 Wellington Ave

Bryan, TX 77803

(979) 209-5528

Open until 11:00 PM

bryantx.gov

Neal Recreation Center - Recreation Center

600 N Randolph Ave

Bryan, TX 77803

(979) 209-5210

bryantx.gov

Brazos Valley Kidz Academy - Day Care Center

306 W 24th St

Bryan, TX 77803

(979) 779-5439

bvkidzacademy.com

CHI St. Joseph Health Regional Hospital - General Hospital

2801 Franciscan St

Bryan, TX 77802

(979) 776-3777

chistjoseph.org

Texas A&M University - University

College Station, TX 77840

(979) 845-2261

Support

2002 E STATE HWY 21, BRYAN, TX 77803

Generated: Wed 02/28/18

✓ SAVE
📄
↻
✓ UNLOCKED REPORT

NEIGHBORHOOD CRIME DATA

[▶ Crime Data Tutorial](#)

NEIGHBORHOOD CRIME DATA



NEIGHBORHOOD ANNUAL CRIMES

	VIOLENT	PROPERTY	TOTAL
Number of Crimes	25	208	233
Crime Rate (per 1,000 residents)	3.61	30.00	33.61

NEIGHBORHOOD VIOLENT CRIME

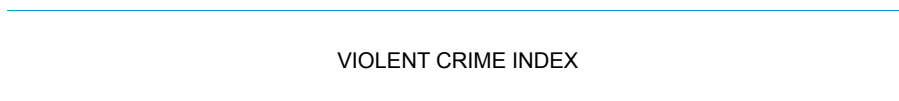



Child Care Search Result Details

[DFPS Home](#) / [Child Care](#) / [Search Texas Child Care](#) / This Page

◀ 2

Operation Details

You may click on the question mark image (?) to view the [Frequently Asked Questions \(FAQ\)](#) page.

Operation Number:	881533
Operation Type:	Licensed Center
Program Provided:	Child Care Program
Operation/Caregiver Name:	Brazos Valley Kidz Academy
Location Address:	306 W 24TH ST BRYAN, TX 77803
Mailing Address:	PO BOX 351 BRYAN, TX 77806
Phone Number:	979-779-5439
County:	BRAZOS
Website Address:	
Email Address:	alicia@bvkidzacademy.com
Administrator/Director Name:	Alicia Sanchez
Type of Issuance: ?	Full Permit
Issuance Date:	11/3/2008
Conditions on Permit: ?	No
Accepts Child-Care Subsidies: ?	Yes
Hours of Operation:	07:15 AM-05:30 PM
Days of Operation:	Monday - Friday
Total Capacity:	75
Licensed to Serve Ages:	Infant, Toddler, Pre-Kindergarten, School
Total Capacity:	75
Number Of Admin Penalties:	0
Corrective Action: ?	No
Adverse Action: ?	No
Temporarily Closed:	No

Two Year Inspection Summary

- Inspectors routinely monitor compliance with Licensing standards, rules and law. At a minimum, licensed and certified operations are inspected at least once a year; Registered Child Care Homes ? are inspected at least once every two years, Listed Family Homes ? are inspected only if there is a report of abuse/neglect or if we receive a report that the home is caring for too many children.



[Home](#)

[Mission](#)

[Learn More](#)

[About Us](#)

[M](#)



Enrollment

Fill out our enrollment form. Our staff is available to answer your questions.

[Read More](#)

Academics

We offer a full range of classes that foster your child's individual growth.

[Read More](#)

Testimonial

Check out our testimonial section for comments and feedback.

[Read More](#)

Child-First Curriculum

We believe that every child is unique and will grow at his or her own pace. Our teachers spend time nurturing children's strengths and encouraging them to reach new heights.

[Read More](#)



Call us today for a tour! 979.779.KIDZ(5439)
306 W. 24th St. Bryan Texas 77803.



Home Find a Store Bryan H-E-B

Bryan H-E-B

Bryan H-E-B

1609 NORTH TEXAS AVENUE
BRYAN, TX 77803-1828
Corporate #644

[Get directions to this Store](#)

Store Hours & Phone Numbers

Main

(979) 778 - 1077

Store Hours

Mon-Sun 06:00 AM - 12:00 AM

Pharmacy

(979) 778 - 2074

Pharmacy Hours

Mon-Fri 09:00 AM - 09:00 PM

Sat 09:00 AM - 06:00 PM

Sun 10:00 AM - 05:00 PM



Here Everything's Better

[View](#)

Available Departments and Services

No Store Does More™ to bring Texas Families the very best locally grown produce, 100 products made around the world - all at great low prices. [Learn More](#)

Store Features

Pharmacy

- Compounding
- Drive Thru
- Immunizations
- Pharmacy

Bakery

- Bakery
- Custom Image Cakes
- Mexican Pastries
- Scratch Bakery
- Tortilleria

Deli

- Deli

Drug and General Merchandise Produce

- Beauty
- Fresh C

Flower Shop

- Floral

Food Services

- Flaming Bird
- Hot Deli
- Take and Bake Pizza

Market

- Bundle Pack

Seafood

- Sushi

Store Se

- Bissell (
- Busines
- Car Wa
- Coin St
- Gas St
- Key Cu

Select your Preferred H-E-B Store >



Home Weekly Ad Weekly Ad Print

Weekly Ad Deals

Stores near [75165-1884](#)

Deals This Week

at **Waxahachie H-E-B**

[Make this my store](#) | [View Nearby Stores](#)

Prices Expire 3/06/2018 Prices valid 2/28/2018 — 3/06/2018

Category View

Print View

Feedback

z19

H-E-B

shop **heb.com** |     

DEALS. RECIPES. COUPONS. MORE.

ON SALE THIS WEEK

Sign up for H-E-B emails at **heb.com** for even more savings! Takes less than one minute!

 <p>Jumbo Cantaloupe</p> <p>98¢ ea.</p>	 <p>Extra Large Greenhouse Tomatoes</p> <p>\$1.28 lb.</p>  <p>Kanzi Apples</p> <p>\$1.97 lb.</p>	 <p>Minneola Tangelos</p> <p>98¢ ea.</p>  <p>Asparagus</p> <p>\$1.99 lb.</p>
 <p>Yellow Nectarines</p> <p>88¢ lb.</p>	 <p>Sweet Onions</p> <p>68¢ lb.</p>  <p>Iceberg Lettuce</p> <p>78¢ ea.</p>	 <p>Organic Yellow Potatoes</p> <p>\$3.99 5 lb.</p>  <p>Organic Large Tangelos</p> <p>\$1.99 lb.</p>

<p>YOUR CHOICE! St. Louis Style Pork Spareribs previously frozen or FRESH! H-E-B Seasoned Boneless, Skinless Chicken Breasts for Fajitas value pack</p>  <p>\$2.49 lb.</p>	<p>FRESH! Assorted Pork Chops bone-in, value pack</p>  <p>\$1.99 lb.</p>	<p>H-E-B Natural Cheese 8 oz. assorted</p>  <p>2 \$1.99 for 2</p>
<p>YOUR CHOICE! FRESH! Country Style Pork Ribs boneless Boston butt cut, or Pork Butt Steaks boneless, Club Pack</p>  <p>\$1.99 lb.</p>	<p>FRESH! Hill Country Fare Split Boneless Skinless Chicken Breast with Rib Meat Fresh! Seasoned Boneless Split Chicken Breasts, \$2.49 lb.</p>  <p>1.99 lb.</p> <p>FRESH! Texas Style Beef Ribs, boneless shoulder USDA Select, value pack</p>  <p>\$2.99 lb.</p>	<p>SAVE \$1! H-E-B Texas Heritage® Smoked Sausage Ring, 12 - 13 oz. assorted varieties</p>  <p>\$2.99 with in-store coupon</p> <p>H-E-B Premium Bacon 12 oz., assorted varieties</p>  <p>2 \$1.99 for 2</p>

<p>FRESH! Atlantic Salmon Fillets boneless farm raised</p>  <p>\$6.97 lb.</p>	<p>WILD! Large Texas Gulf Shrimp 31 - 40 ct. per pound previously frozen</p>  <p>\$6.77 lb.</p>	<p>BUY H-E-B! H-E-B Meal Simple™ Cod Portions with Parmesan Grilled Beans, 5 oz. GET FREE! Ken's Steak House® Tartar Sauce, 4 oz. SAVE UP TO \$5!</p> 
--	---	--

SAVE ON THE ITEMS YOU USE MOST

<p>Nice 'N Clean Moist Wipes 42 - 180 ct.</p>  <p>SAVE 50¢ with in-store coupon</p>	<p>Chinet Paper Plates or Platters 15 ct. assorted varieties</p>  <p>SAVE \$1 with in-store coupon</p>	<p>SAVE \$3! H-E-B Pets® Adult Complete Dry Dog Food 50 lb.</p>  <p>\$16.28 ea.</p>
<p>SAVE \$2! Seventh Generation Liquid Laundry Detergent 54 - 56 loads assorted varieties</p>  <p>\$10.54 ea. with in-store coupon</p>	<p>SAVE \$1.50! Clorox Disinfecting Wipes 70 - 75 ct. assorted varieties</p>  <p>\$3.48 ea. with in-store coupon</p>	<p>Glade Candles, 3 oz. Spray Refill, 6.2 oz. Wax Melts, 8 - 8 ct. assorted varieties (excludes Warmers, Aerosol, 8 oz., and 50 oz.)</p>  <p>SAVE \$3 with in-store coupon when you buy 3</p>
<p>Huggies Baby Wipes 68 - 240 ct. assorted varieties</p>  <p>2 \$10 with in-store coupon when you buy 2</p>	<p>when you buy \$20 of Depend or Poise Products (includes Poise Impressa)</p>  <p>SAVE \$2.50 off your basket with in-store coupon</p>	<p>when you buy \$15 of TRE Semolina or Dove Men + Care Hair Care, Body or Deodorant Products (excludes antiperspirant)</p>  <p>SAVE \$5 off your basket with in-store coupon</p>

Feedback

Our Services

- Curbside & Home Delivery
- Ship to Home
- Order Ahead: Bakery & Deli
- Pharmacy
- Optical by H-E-B
- Restaurants
- Business Center
- Gift Cards

Customer Service

- Contact Us
- Help & FAQs
- Coupon Policy
- Refund Policy
- Product Recalls

More from H-E-B

- My H-E-B Texas Life Magazine
- Primo Picks
- Recipes & Cooking



Feedback

[Participate in H-E-B Customer Research](#)



Don't Let The Flu Catch You

Immunization is the best way to protect yourself and loved ones.

[Get Flu Shot ▶](#)



Refill Prescription



Check Refill Status



Refill Xpress

Need to order a refill?

Simply enter the information as printed on your current prescription label.

Refill two or more prescriptions

First Name *

Last Name *

Date of Birth *

Corp # *

Prescription # *

[Continue](#)

Feedback



New H-E-B Pharmacy App
 Now Available for Download!



Pharmacy Services



Specialty Pharmacy

Prescription Delivery

Prescription Compounding

Prescription Flavoring

Pet Medications

\$4 Generics

Health Services

Feedback



Immunizations

Health Screenings

Nutrition Services

Medicare

Lab Services

Diabetes Products

Rx Advantage for Employers

[H-E-B Retail Health Care Services Notice of Privacy Practice](#) | [Health Care Nondiscrimination](#)
[Texas State Board of Pharmacy](#) | [How to Dispose of Unused Medicines](#)

SIGN UP FOR
EMAIL UPDATES

Sign up to receive exclusive email-only savings and information.

Enter your email address

Go

Feedback

Company

- Find a Store
- About Us
- Careers

- Community
- Newsroom
- Corporate Responsibility
- Our Brands
- Store Openings

Our Services

- Curbside & Home Delivery
- Ship to Home
- Order Ahead: Bakery & Deli
- Pharmacy
- Optical by H-E-B
- Restaurants
- Business Center
- Gift Cards

Customer Service

- Contact Us
- Help & FAQs
- Coupon Policy
- Refund Policy
- Product Recalls

More from H-E-B

- My H-E-B Texas Life Magazine
- Primo Picks
- Recipes & Cooking



area that is specifically designed for physically handicapped individuals, including a running cable for the visually impaired. (23 acres)

Scurry Park

Address: 1501 Wellington Street

Amenities:

- Pavilion
- Restrooms
- Basketball Court
- Playground
- Picnic Tables with BBQ Grills
- Jogging/Walking Trail
- Softball/Baseball Backstop
- BBQ Grill
- Area Lighting
- Parking

This is the oldest park in Bryan established in the 1890's and originally named Oak Grove Park. Some of the city's most beautiful Post Oaks are located here. The neighborhood park is located on Wellington St., adjacent to the Southern Pacific Railroad tracks. The park has two playground units, swings, restrooms, a picnic pavilion and picnic tables with BBQ grills, a practice baseball/softball backstop, a lighted basketball court and a 1/2 mile jogging/walking trail.(7 acres)

HELP >

- [Contact Us](#)
- [Menus](#)
- [Search](#)

Address: 1929 Country Club Drive
Phone: (979) 776-0133

Neal Recreation Center

Address: 600 N. Randolph

Phone: (979) 209-5210

Hours:

- **Monday – Thursday:** 8 a.m. - 9 p.m.
- **Friday:** 8 a.m. - 7 p.m.

Amenities:

- Full-service activity center with a large gymnasium and several activity rooms.

The Gymnasium is designed for multi-use programming and is equipped with a curtain, which allows it to divide in half. The meeting rooms and gymnasium are available for rental.

A state-of-the-art Fitness Room, with the latest in Cybex exercise equipment, is open to patrons 16 years and older throughout the day.

The Teen Room is available to individuals 13 years and up, featuring two foosball tables, two pool tables, and air hockey.

The Classrooms include an arts and crafts room, multi-media room, and multi-purpose room.

Admission Fees (Resident; Non-Resident)

- **Daily:** \$2; \$4
- **School Year Individual:** \$55; \$66
- **School Year Family (up to 2):** \$82; \$98
- **Each additional family member:** \$20; \$24
- **Summer Individual (end of school to beginning of school):** \$40; \$48
- **Summer Family (up to 2 — end of school to beginning of school):** \$60; \$72
- **Each additional family member:** \$15; \$18
- **Fitness Room – 16 years and older only (annual membership):** \$108; \$137
- **Fitness Room – 16 years and older only (monthly membership):** \$9; \$12

Room/Building Rental Fees (Resident; Non-Resident)

- **Gym (hourly):** \$50; \$60
- **1/2 Gym (hourly):** \$25; \$30
- **Gym (8 hours):** \$375; \$450
- **Arts and Crafts Room:** \$20; \$24
- **Multi-media Room:** \$20; \$24
- **Multi-purpose Room w/kitchen:** \$40; \$48
- **Building Rental (hourly):** \$150; \$180
- **Set up/Take down (optional):** \$75; \$89
- **Cleaning Deposit*:** \$50; \$60

includes TVWCR

Table and chairs will be available for an additional fee.

Rental agreement – Please read (PDF)

User must also comply with rental agreement, which may require additional security or guidelines as determined by the Division Manager or his/her designee.

*Cleaning Deposit refundable if rental rooms left in clean condition.

Open Gym for Pickup Basketball – Recreation Play

Beginning Oct. 4, the gym will be open for basketball on the following dates and times:

- **Wednesday:** 6 p.m. - 9 p.m.
- **Sunday:** 5 p.m. - 8 p.m.
- **Cost:** \$2 Resident; \$4 Non-Resident; Free to NRC Members
- **Ages:** 16 and up

Services



 [SCHEDULE A DOCTOR'S APPOINTMENT](#)

[Home](#) > [Services](#)

- Assisted Living
- Cancer
- Children's Care
- Diabetes
- Ear Nose & Throat
- Emergency
- General Surgery
- Heart Care
- Imaging & Radiology
- Laboratory
- Long Term Care
- Mammography
- Maternity
- Neurology
- Neurosurgery
- Occupational Medicine
- Orthopedic Care
- Pain Management
- Palliative & Supportive Care
- Pediatrics
- Primary Care
- Therapy
- Robotic Surgery
- Seniors
- Sleep Disorders
- Skilled Nursing
- Stroke Care
- Trauma
- Weight Loss
- Wellness
- Wound Care
- Urology



Find businesses

e.g. Tesla Motors

business name

all states

city, state, or zip code

Search



Allen, TX: This Brilliant Company Is Disrupting A \$200 Billion Industry

EVERQUOTE

[Texas](#)
[BR](#)
[BRAZOS VALLEY COMMUNITY CHURCH OF GOD ...](#)

Business Directory of Texas. BRAZOS VALLEY COMMUNITY CHURCH OF GOD ...

[← BRAZOS VALLEY COAL CLAY&MANUFACTURING CO](#)

[BRAZOS VALLEY CONCRETE SERVICES LLC →](#)

BRAZOS VALLEY COMMUNITY CHURCH OF GOD

Bryan, TX

Industry:

Religious Organization

Doing business as:

Brazos Valley Community Church of God, Inc

Brazos Valley Community Church of God

Bryan Church of God Inc

Registration:

May 10, 1982

Phone:

(979) 778-7680

Addresses:

2002 Highway 21 E, Bryan, TX 77803 (Mailing)

2206 Highway 21 E, Bryan, TX 77803

PO Box 1296, Bryan, TX 77806

State ID:

0060732001

Business type:

Domestic Nonprofit Corporation

Members (12):

Warren Roberts (Principal, Pastor)

Sheldon T. Smith (President)

Sandra Coleman (Treasurer)

Cynthia J. Roberts (Secretary)

Charli M. Jones (Director)

...

Agent:

Terrence B. Roberts

2002 Hwy 21 E., Bryan, TX 77806 (Physical)

TIN:

30006591033

Categories:



Brazos Valley Community Church of God @brazosvalleycommunitycog

- Home
Posts
Reviews
Photos
About
Community



Like Follow Share

Send Message

INSTANT GAMES and YOUR GAMES section with game icons like Sweet's, W3, and Super!

- Michelle Jones
Emmanuel Will
Christina Spencer
Josh Albillo
Karrel Koll Bell
Amgrateful Grate Lyfe
Cindy Love
Zenzo Matoga
Amanda Banda
Javier Maga Ben
Charese Nicole Mathh
Jordache Vincent Grant
Cheryl Fombon Delo
Baron Bacon
Bernetta Nearhood K
Emmanuel Ogiozee
Briana Shaw-Collins
Simone Doss
AJ Gum
Daniel Phillips
Gina Soda
Sondra Ortega
MORE CONTACTS (19)
Anna Hinda

Public Posts at Brazos Valley Community Church of God

Deshonda Payton Smith shared a post to Brazos Valley Community Church of God's timeline. August 5, 2017



Deshonda Payton Smith added 24 new photos. August 5, 2017

Like Comment Share
Write a comment...

Deshonda Payton Smith Brazos Valley Community Church of God August 5, 2017
Come join us for our Back to School with the Right Tools Bash!!

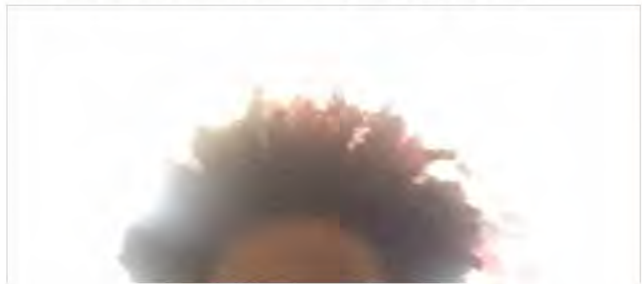

43 Total Likes To

- Invite your friends to like Brazos Valley Community Church of God
Audry Owens
Valeria Rispoli
Nina Botchway Montoya
See All Friends

English (US) Español Português Français (France) Deutsch
Privacy Terms Advertising Ad Cookies More - Facebook © 2018

Brazos Valley Community Church of God
@brazosvalleycommunitycog

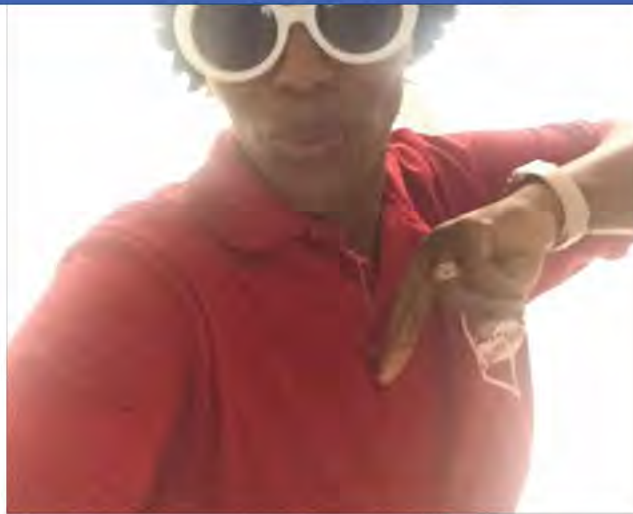

Like Comment Share

5

Chronological



Tomi R Johnson I love it sis!!

Like Reply 29w



Write a comment...



Tomi R Johnson Brazos Valley Community Church of God

July 12, 2017

Aww yea: It's that time of year!! Bring your kids out for some food, fun & fellowship that will equip them for the upcoming school year. Tag a friend, share, but by all means join us!!

👍👏👍 — with Martin Aguilar Jr. and 2 others.

BACK TO SCHOOL WITH THE

August 5th
2pm - 5pm

Brazos Valley Community Church Of God
2002 Hwy 21 East, Bryan TX 77803

WORDS OF ENCOURAGEMENT BY
APOSTLE TONY
HERNANDEZ

RIGHT TOOLS

Knockerballs, Food, Games & School Supplies

Live performance by **LIL' DRE**

"His divine power has given us everything we need for a godly life through our knowledge of him who called us by his own glory and goodness."
2 Peter 1:3

Like Comment Share

10

INSTANT GAMES MORE







YOUR GAMES MORE



- Michelle Jones
 - Emmanuel Will
 - Christina Spencer
 - Josh Albillo
 - Karrel Koll Bell
 - Amgrateful Grate Lyfe
 - Cindy Love
 - Zenzo Matoga
 - Amanda Banda
 - Javier Maga Ben
 - Charese Nicole Math
 - Jordache Vincent Grant
 - Cheryl Fombon Delo
 - Baron Bacon
 - Bernetta Nearhood K
 - Emmanuel Ogiozee
 - Briana Shaw-Collins
 - Simone Doss
 - AJ Gum
 - Daniel Phillips
 - Gina Soda
 - Sondra Ortega
- MORE CONTACTS (19)
- Anna Hinda

Search Settings

Write a comment...    

See More ▾

**Brazos Valley
Community Church
of God**
@brazosvalleycommunity
cog

INSTANT GAMES MORE



























YOUR GAMES MORE





-  Michelle Jones ●
 -  Emmanuel Will ●
 -  Christina Spencer ●
 -  Josh Albillo ●
 -  Karrel Koll Bell ●
 -  Amgrateful Grate Lyfe ●
 -  Cindy Love ●
 -  Zenzo Matoga ●
 -  Amanda Banda ●
 -  Javier Maga Ben ●
 -  Charese Nicole Mathh ●
 -  Jordache Vincent Grant ●
 -  Cheryl Fombon Delo ●
 -  Baron Bacon ●
 -  Bernetta Nearhood K ●
 -  Emmanuel Ogiozee ●
 -  Briana Shaw-Collins ●
 -  Simone Doss ●
 -  AJ Gum ●
 -  Daniel Phillips ●
 -  Gina Soda ●
 -  Sondra Ortega ●
- MORE CONTACTS (19)**
-  Anna Hinda ●

T * E * X * A * S HIGHER EDUCATION DATA

Search

GO

Overview (Quick Links) | External Data Resources | Online Applications | Workforce | Higher Education Topics | High School to College (P-16) | Reporting to THECB | A-Z Index

Policymakers

Accountability, almanac, financials...

Parents, Students & K-12 Educators

Online Resume, H.S. to college stats...

Media

Overview, Almanac, Press Releases...

Institutions and Researchers

Reporting data, statistics...

Career and Workforce Educators

Perkins, WECM, Workforce Topics...

Public Universities

[Download the Excel Version](#)

Institution	Administrative Officer	Main Telephone
Angelo State University 2601 W. Avenue N San Angelo, TX 76909	Brian J. May President	(325) 942-2073
Lamar University 4400 Martin L. King Boulevard Beaumont, TX 77710	Kenneth Evans President	(409) 880-7011
Midwestern State University 3410 Taft Boulevard Wichita Falls, TX 76308-2099	Suzanne Shipley President	(940) 397-4000
Prairie View A&M University FM 1098 & University Drive Prairie View, TX 77446	Ruth J. Simmons Interim President	(936) 857-3311
Sam Houston State University 1806 Avenue J Huntsville, TX 77341	Dana G. Hoyt President	(866) 294-1111
Stephen F. Austin State University 1936 North Street Nacogdoches, TX 75962	Baker Pattillo President	(936) 468-2011
Sul Ross State University East Highway 90 Alpine, TX 79832	William (Bill) Kibler President	(432) 837-8011
Sul Ross State University Rio Grande College Route 3, Box 1200 Eagle Pass, TX 78852	William (Bill) Kibler President	(830) 278-3339
Tarleton State University 1333 West Washington Stephenville, TX 76402	F. Dominic Dottavio President	(254) 968-9000
Texas A&M International University 5201 University Boulevard Laredo, TX 78041	Pablo Arenaz President	(956) 326-2001
Texas A&M University 1265 TAMU College Station, TX 77843-1265	Michael K. Young President	(979) 845-3211
Texas A&M University at Galveston Seawolf Parkway Galveston, TX 77553	Robert Smith III President	(877) 322-4443
Texas A&M University System Moore Connally Bldg 301 Tarrow College Station, TX 77840-7896	John Sharp Chancellor	(979) 458-6000
Texas A&M University-Central Texas 1001 Leadership Place Killeen, TX 76549	Marc Nigliazzo President	(254) 519-5400
Texas A&M University-Commerce 1700 Hwy 24 Commerce, TX 75429	Ray M. Keck III President	(903) 886-5014
Texas A&M University-Corpus Christi 6300 Ocean Drive Corpus Christi, TX 78412	Kelly M. Quintanilla Interim President	(361) 825-5700
Texas A&M University-Kingsville 700 University Boulevard Kingsville, TX 78363	Steven H. Tallant President	(361) 593-3207
Texas A&M University-San Antonio One University Way San Antonio, TX 78224	Cynthia Teniente-Matson President	(210) 932-6299
Texas A&M University-Texarkana 7101 University Avenue Texarkana, TX 75503	Emily F. Cutrer President	(903) 223-3000
Texas Southern University 3100 Cleburne Avenue Houston, TX 77004	Austin A. Lane President	(713) 313-7011
Texas State University 601 University Drive San Marcos, TX 78666	Denise Trauth President	(512) 245-2111
Texas State University System 200 East 10th Street Suite 600 Austin, TX 78701	Brian McCall Chancellor	(512) 245-2111
Texas Tech University 2500 Broadway Lubbock, TX 79409	Lawrence Schovanec President	(806) 742-2011

Latest News

02/20/2018	Applicants Acceptance Enrollment Updated for 2017
02/12/2018	Longitudinal Degrees and Enrollment Updated for 2017
02/12/2018	Certified Fall 2017 Texas Higher Ed Enrollment Data
02/06/2018	Dual Credit Enrollment Data Updated for 2017
02/01/2018	2015-2016 HS Grads GPA in Higher Ed Report

e-UPDATES

subscribe to updates

Texas Tech University System P.O. Box 42013 Lubbock, TX 79409	Robert L. Duncan Chancellor	(806) 742-2011
Texas Woman's University 304 Administration Drive Denton, TX 76204-5589	Carine M. Feyten Chancellor/President	(940) 898-3201
The University of Texas at Arlington 701 S. Nedderman Drive Arlington, TX 76019	Vistasp M. Karbhari President	(817) 272-2011
The University of Texas at Austin University Station Austin, TX 78712	Gregory L. Fennes President	(512) 471-3434
The University of Texas at Dallas 800 West Campbell Road Richardson, TX 75080-3021	Richard C. Benson President	(972) 883-2111
The University of Texas at El Paso 500 West University Avenue El Paso, TX 79968	Diana Natalicio President	(915) 747-5000
The University of Texas at San Antonio One UTSA Circle San Antonio, TX 78249-0601	Taylor Eighmy President	(210) 458-4011
The University of Texas at Tyler 3900 University Boulevard Tyler, TX 75799	Michael V. Tidwell President	(903) 566-7000
The University of Texas of the Permian Basin 4901 East University Odessa, TX 79762	Sandra K. Woodley President	(432) 552-2020
The University of Texas Rio Grande Valley 1201 West University Drive Edinburg, TX 78541	Guy Bailey President	(956) 381-2011
The University of Texas System 601 Colorado Austin, TX 78701-2982	William H. McRaven Chancellor	(512) 499-4201
University of Houston 4800 Calhoun Road Houston, TX 77204	Renu Khator President	(713) 743-8820
University of Houston System 3100 Cullen Boulevard Suite 205 Houston, TX 77204-6001	Renu Khator Chancellor	(713) 743-1000
University of Houston-Clear Lake 2700 Bay Area Boulevard Houston, TX 77058-1098	Ira K. Blake President	(281) 283-7600
University of Houston-Downtown One Main Street Houston, TX 77002	Juan Sánchez Muñoz President	(713) 221-8000
University of Houston-Victoria 3007 N. Ben Wilson Victoria, TX 77901-5731	Vic Morgan President	(361) 570-4848
University of North Texas 1155 Union Circle #311277 Denton, TX 76203	Neal J. Smatresk President	(940) 565-2000
University of North Texas at Dallas 7300 University Hills Boulevard Dallas, TX 75241	Robert Mong President	(972) 780-3602
University of North Texas System 1901 Main Street Dallas, TX 75201	Lesa Roe Chancellor	(940) 565-2000
UNT Dallas College of Law 1901 Main Street Dallas, TX 75201	Royal Furgeson Dean	(214)752-3232
West Texas A&M University 2501 4th Avenue Canyon, TX 79016	Walter Wendler President	(806) 651-2000



DEGREES AND PROGRAMS OFFERED

Degree Programs Tables

Undergraduate, Graduate and Professional Degree Programs

Approved by the Texas Higher Education Coordinating Board

Interdisciplinary Degree Programs

Degree Program	Baccalaureate	Masters	Doctorate	Professional
Agribusiness		MAB		
Agribusiness and Managerial Economics			PhD	
Biotechnology		MBIOT		
Ecology and Evolutionary Biology			PhD	
Energy		MS		
Environmental Studies	BS			
Genetics ¹		MS	PhD	
Marine Biology ²		MS	PhD	
Molecular and Environmental Plant Sciences		MS	PhD	
Neuroscience		MS	PhD	
Spatial Sciences	BS			
Toxicology		MS	PhD	
University Studies	BA, BS			
Water Management and Hydrological Science		MS, MWM	PhD	

¹ Administered by the Colleges of Agriculture and Life Sciences, Medicine, Science and Veterinary Medicine and Biomedical Sciences.
² Joint program with Texas A&M University, Texas A&M University at Galveston and Texas A&M University–Corpus Christi.

College of Agriculture and Life Sciences

Degree Program	Baccalaureate	Masters	Doctorate	Professional
Renewable Natural Resources	BS			
Department of Agricultural Economics				
Agribusiness	BS			
Agricultural Economics	BS	MS, MAgr	PhD	
Department of Agricultural Leadership, Education and Communications				
Agricultural Communication and Journalism	BS			
Agricultural Development		MAgr		

Agricultural Education			Edd ¹	
Agricultural Leadership and Development ²	BS			
Agricultural Leadership, Education, and Communication ²		MS, MEd	PhD	
Agricultural Science ²	BS			
Department of Animal Science				
Animal Breeding		MS	PhD	
Animal Science	BS	MS, MAgr	PhD	
Equine Industry Management		MEIM		
Physiology of Reproduction		MS	PhD	
Department of Biochemistry and Biophysics				
Biochemistry	BS	MS	PhD	
Genetics	BS			
Department of Biological and Agricultural Engineering				
Agricultural Systems Management	BS	MS, MAgr		
Biological and Agricultural Engineering	BS	MS, MEngr	PhD	
Department of Ecosystem Science and Management				
Ecological Restoration	BS			
Ecosystem Science and Management		MS, MAgr	PhD	
Forestry	BS			
Natural Resources Development		MNRD		
Rangeland Ecology and Management	BS			
Spatial Sciences	BS			
Department of Entomology				
Entomology	BS	MS	PhD	
Forensic and Investigative Sciences	BS			
Department of Horticultural Sciences				
Horticulture	BA, BS	MS, MAgr	PhD ³	
Plant Breeding		MS	PhD	

Department of Nutrition and Food Science

Food Science and Technology	BS	MS, MAgr	PhD
Nutrition	BS	MS	PhD

Department of Plant Pathology and Microbiology

Bioenvironmen Sciences	BS		
Plant Pathology		MS	PhD

Department of Poultry Science

Poultry Science	BS	MS, MAgr	PhD
-----------------	----	----------	-----

Department of Recreation, Park and Tourism Sciences

Natural Resources Development		MNRD	
Recreation, Park and Tourism Sciences	BS	MS	PhD
Recreation and Resources Development		MRRD	

Department of Soil and Crop Sciences

Agronomy		MS	PhD
Plant Breeding		MS	PhD
Plant and Environmental Soil Science	BS		
Soil Science		MS	PhD
Turfgrass Science	BS		

Department of Wildlife and Fisheries Sciences

Natural Resources Development		MNRD	
Wildlife and Fisheries Sciences	BS	MS	PhD
Wildlife Science		MWSC	

- ¹ Also offered as joint program with Texas Tech University when offered by Distance Education.
- ² Joint Program with College of Education and Human Development. Degrees conferred in College of Agriculture and Life Sciences.
- ³ Also offered as cooperative program with Texas A&M University–Kingsville.

College of Architecture

Degree Program	Baccalaureate	Masters	Doctorate	Professional
Department of Architecture				
Architecture		MS, MArch	PhD	

Environmental Design Architectural Studies BED

Department of Construction Science

Construction Science	BS		
Construction Management		MS	

Department of Landscape Architecture and Urban Planning

Landscape Architecture	BLA	MLA	
Land and Property Development		MLPD	
Urban and Regional Planning	BS	MUP	
Urban and Regional Science			PhD

Department of Visualization

Visualization	BS	MS, MFA	
---------------	----	---------	--

Mays Business School

Degree Program	Baccalaureate	Masters	Doctorate	Professional
Business Administration				
Business Administration	BBA	MBA	PhD	
Business Honors	BBA			

Department of Accounting

Accounting	BBA	MS	
------------	-----	----	--

Department of Finance

Finance	BBA	MS	
Financial Management		MFM	
Land Economics and Real Estate		MRE	

Department of Information and Operations Management

Management Information Systems	BBA	MS	
Supply Chain Management	BBA		

Department of Management

Entrepreneurial Leadership		MS	
Human Resource Management		MS	
Management	BBA		PhD

Department of Marketing

Marketing	BBA	MS		
-----------	-----	----	--	--

College of Dentistry

Degree Program	Baccalaureate	Masters	Doctorate	Professional
Dentistry				DDS
Oral Biology		MS	PhD	

Department of Biomedical Sciences

Caruth School of Dental Hygiene

Dental Hygiene BS

Department of Diagnostic Sciences

Department of Endodontics

Department of General Dentistry

Department of Oral and Maxillofacial Surgery

Department of Orthodontics

Department of Pediatric Dentistry

Department of Periodontics

Department of Public Health Sciences

Department of Restorative Sciences

College of Education and Human Development

Degree Program	Baccalaureate	Masters	Doctorate	Professional
----------------	---------------	---------	-----------	--------------

Department of Educational Administration and Human Resource Development

Educational Administration MS, MEd PhD, EdD¹

Educational Human Resource Development MS PhD

Human Resource Development BS

Technology Management BS

Department of Educational Psychology

Bilingual Education MS, MEd

Counseling Psychology PhD

Educational Psychology MS, MEd PhD

Educational Technology MEd

School Psychology PhD

Special Education		MS, MEd		
-------------------	--	---------	--	--

Department of Health and Kinesiology

Athletic Training		MS		
-------------------	--	----	--	--

Community Health BS

Health BS

Health Education MS PhD

Kinesiology BS MS PhD

Sport Management BS MS

Department of Teaching, Learning and Culture

Curriculum and Instruction MS, MEd² PhD, EdD¹

Interdisciplinary Studies BS

¹ Also offered as a Cooperative Doctoral Program with Texas A&M International University.

² Also offered as a dual degree program with Qatar University.

College of Engineering

Degree Program	Baccalaureate	Masters	Doctorate	Professional
----------------	---------------	---------	-----------	--------------

Engineering MEngr DEngr

Interdisciplinary Engineering BS MS PhD

Safety Engineering MS

Systems Engineering MEngr

Department of Aerospace Engineering

Aerospace Engineering BS MS, MEngr PhD

Department of Biomedical Engineering

Biomedical Engineering BS MS, MEngr PhD

Artie McFerrin Department of Chemical Engineering

Chemical Engineering BS MS, MEngr PhD

Zachry

Department of Civil Engineering

Civil Engineering BS MS, MEngr PhD

Department of Computer Science and Engineering

Computer Engineering BS MS, MEngr PhD

Computer Science BS MS, MCS PhD

Department of Electrical and Computer Engineering

Computer Engineering	BS	MS, MEngr	PhD
Electrical Engineering	BS	MS, MEngr	PhD

Department of Engineering Technology and Industrial Distribution

Electronic Systems Engineering Technology	BS		
Industrial Distribution	BS	MID	
Manufacturing and Mechanical Engineering Technology	BS		
Multidisciplinary Engineering Technology	BS		
Technical Management		METM	

Department of Industrial and Systems Engineering

Engineering Systems Management		MS	
Industrial Engineering	BS	MS, MEngr	PhD

Department of Materials Science and Engineering

Materials Science and Engineering		MS, MEngr	PhD
-----------------------------------	--	-----------	-----

Department of Mechanical Engineering

Mechanical Engineering	BS	MS, MEngr	PhD
------------------------	----	-----------	-----

Department of Nuclear Engineering

Nuclear Engineering	BS	MS, MEngr	PhD
---------------------	----	-----------	-----

Department of Ocean Engineering

Ocean Engineering	BS	MS, MEngr	PhD
-------------------	----	-----------	-----

Harold Vance Department of Petroleum Engineering

Petroleum Engineering	BS	MS, MEngr	PhD
-----------------------	----	-----------	-----

College of Geosciences

Degree Program	Baccalaureate	Masters	Doctorate	Professional
Environmental Geoscience	BS			

Environmental Studies	BS		
Geoscience		MGsc	

Department of Atmospheric Sciences

Atmospheric Sciences		MS	PhD
Meteorology	BS		

Department of Geography

Geographic Information Science and Technology	BS		
Geography	BS	MS	PhD

Department of Geology and Geophysics

Geology	BA, BS	MS	PhD
Geophysics	BS	MS	PhD

Department of Oceanography

Ocean Science and Technology		MOST	
Oceanography	BS	MS	PhD

The Bush School of Government and Public Service

Degree Program	Baccalaureate	Masters	Doctorate	Professional
----------------	---------------	---------	-----------	--------------

Department of International Affairs

International Affairs		MIA		
-----------------------	--	-----	--	--

Department of Public Service and Administration

Public Service and Administration		MPSA		
-----------------------------------	--	------	--	--

School of Law

Degree Program	Baccalaureate	Masters	Doctorate	Professional
----------------	---------------	---------	-----------	--------------

Health Care Law		JM		
Intellectual Property		LLM, MJur		
Jurisprudence		MJur		
Law				JD
Laws		LLM		

College of Liberal Arts

Degree Program	Baccalaureate	Masters	Doctorate	Professional
----------------	---------------	---------	-----------	--------------

Women's and Gender Studies	BA			
----------------------------	----	--	--	--

Department of Anthropology

Anthropology	BA	MA	PhD
Maritime Archaeology and Conservation		MS	

Department of Communication

Communication	BA	MA	PhD
Telecommunication and Media Studies	BA, BS		

Department of Economics

Economics	BA, BS	MS	PhD
-----------	--------	----	-----

Department of English

English	BA	MA	PhD
---------	----	----	-----

Department of Hispanic Studies

Hispanic Studies		MA	PhD ¹
Spanish	BA		

Department of History

History	BA	MA	PhD
---------	----	----	-----

Department of International Studies

Classics	BA		
International Studies	BA		
Modern Languages	BA		

Department of Performance Studies

Performance Studies	BA	MA	
---------------------	----	----	--

Department of Philosophy and Humanities

Philosophy	BA	MA	PhD
------------	----	----	-----

Department of Political Science

Political Science	BA, BS	MA	PhD
-------------------	--------	----	-----

Department of Psychology

Clinical Psychology			PhD
Industrial/Organizational Psychology			PhD
Psychology	BA, BS	MS	PhD

Department of Sociology

Sociology	BA, BS	MS	PhD
-----------	--------	----	-----

¹ Step 1 Doctoral Program with Texas A&M International University, Texas A&M University – Corpus Christi and Texas A&M University – Kingsville.

College of Medicine

Degree Program	Baccalaureate	Masters	Doctorate	Professional
Education for Health Care Professionals		MS		
Medical Sciences		MS	PhD	
Medicine				MD

Department of Anesthesiology

Department of Clinical Translational Medicine

Department of Emergency Medicine

Department of Family and Community Medicine

Department of Humanities in Medicine

Department of Internal Medicine

Department of Medical Physiology

Department of Microbial Pathogenesis and Immunology

Department of Molecular and Cellular Medicine

Department of Neurosciences and Experimental Therapeutics

Department of Obstetrics and Gynecology

Department of Pathology

Department of Pediatrics

Department of Psychiatry and Behavioral Science

Department of Radiology

Department of Surgery

College of Nursing

Degree Program	Baccalaureate	Masters	Doctorate	Professional
Family Nurse Practitioner		MSN		
Forensic Nursing		MSN		
Nursing	BSN			
Nursing Education		MSN		

Irma Lerma Rangel College of Pharmacy

Degree Program	Baccalaureate	Masters	Doctorate	Professional
Pharmacy				PharmD

Department of Pharmaceutical Sciences

Department of Pharmacy Practice

School of Public Health

Degree Program	Baccalaureate	Masters	Doctorate	Professional
Epidemiology and Environmental Health			DrPH	
Health Administration		MHA		
Health Policy and Management		MSPH		
Health Services Research			PhD	

Occupational Safety and Health	MPH		
Department of Epidemiology and Biostatistics			
Biostatistics	MPH		
Epidemiology	MPH		
Department of Environmental and Occupational Health			
Environmental Health	MPH		
Department of Health Policy and Management			
Health Policy and Management	MPH		
Department of Health Promotion and Community Health Sciences			
Health Promotion and Community Health Sciences	MPH	DrPH	
Department of Public Health Studies			
Public Health	BS		

College of Science

Degree Program	Baccalaureate	Masters	Doctorate	Professional
Department of Biology				
Biology	BA, BS	MS	PhD	
Microbiology	BS	MS	PhD	
Molecular and Cell Biology	BS			
Zoology	BS			
Department of Chemistry				
Chemistry	BA, BS	MS	PhD	
Department of Mathematics				
Applied Mathematical Sciences	BS			
Mathematics	BA, BS	MS	PhD	
Department of Physics and Astronomy				
Astronomy		MS	PhD	
Physics	BA, BS	MS	PhD	
Applied Physics			PhD	
Department of Statistics				
Analytics		MS		
Statistics	BS	MS	PhD	

College of Veterinary Medicine and Biomedical Sciences

Degree Program	Baccalaureate	Masters	Doctorate	Professional
Biomedical Sciences	BS	MS	PhD	

Science and Technology Journalism	MS		
Veterinary Medicine			DVM
Department of Veterinary Integrative Biosciences			
Veterinary Public Health - Epidemiology	MS		
Department of Veterinary Large Animal Clinical Sciences			
Department of Veterinary Pathobiology			
Department of Veterinary Physiology and Pharmacology			
Department of Veterinary Small Animal Clinical Sciences			

Texas A&M University Galveston Campus

Degree Program	Baccalaureate	Masters	Doctorate	Professional
University Studies	BA, BS			
Department of Liberal Studies				
Maritime Studies	BA			
Department of Marine Biology				
Marine Biology	BS	MS ¹	PhD ¹	
Marine Fisheries	BS			
Department of Marine Engineering Technology				
Marine Engineering Technology	BS			
Department of Marine Sciences				
Marine Resources Management		MMRM		
Marine Sciences	BS			
Ocean and Coastal Resources	BS			
Department of Maritime Administration				
Maritime Administration	BS			
Maritime Administration and Logistics		MMAL		
Department of Maritime Systems Engineering				

**Department
of Maritime
Transportation**

Marine Transportation	BS
--------------------------	----

¹ Joint program between Texas A&M University, Texas A&M University at Galveston and Texas A&M University – Corpus Christi.

Texas A&M University Qatar Campus

Degree Program	Baccalaureate	Masters	Doctorate	Professional
College of Engineering				
Chemical Engineering	BS	MS, MEngr		
Electrical Engineering	BS			
Mechanical Engineering	BS			
Petroleum Engineering	BS			

Degree Programs Via Distance Education

Texas A&M University currently offers the following programs by distance education:

Undergraduate Degree Program

- Bachelor of Science in Nursing (BSN) in Nursing

Graduate Degree Programs

- Doctor of Education (EdD) in Agricultural Education
- Doctor of Education (EdD) in Curriculum and Instruction
- Doctor of Philosophy (PhD) in Plant Breeding
- Master of Agriculture (MAgr) in Agricultural Development
- Master of Agriculture (MAgr) in Poultry Science
- Master of Education (MEd) in Bilingual Education
- Master of Education (MEd) in Curriculum and Instruction
- Master of Education (MEd) in Educational Administration
- Master of Education (MEd) in Educational Psychology
- Master of Education (MEd) in Educational Technology
- Master of Education (MEd) in Special Education
- Master of Engineering (MEng) in Aerospace
- Master of Engineering (MEng) in Biological and Agricultural Engineering
- Master of Engineering (MEng) in Computer Engineering
- Master of Engineering (MEng) in Electrical Engineering
- Master of Engineering (MEng) in Engineering
- Master of Engineering (MEng) in Industrial Engineering
- Master of Engineering (MEng) in Mechanical Engineering
- Master of Engineering (MEng) in Petroleum Engineering
- Master of Engineering Technical Management (METM) in Technical Management
- Master of Geoscience (MGSC) in Geoscience
- Master of Industrial Distribution (MID) in Industrial Distribution
- Master of Jurisprudence (MJur) in Jurisprudence
- Master of Laws (LLM) in Laws

- Master of Maritime Administration and Logistics (MMAL) in Maritime Administration and Logistics
- Master of Natural Resource Development (MNRD) in Natural Resource Development
- Master of Public Health (MPH) in Epidemiology
- Master of Public Service and Administration (MPSA) in Public Service and Administration
- Master of Recreation and Resources Development (MRRD) in Recreation and Resources Development
- Master of Science (MS) in Agricultural Systems Management
- Master of Science (MS) in Analytics
- Master of Science (MS) in Bilingual Education
- Master of Science (MS) in Education for Health Care Professionals
- Master of Science (MS) in Educational Human Resource Development
- Master of Science (MS) in Educational Psychology
- Master of Science (MS) in Energy
- Master of Science (MS) in Engineering Systems Management
- Master of Science (MS) in Health Education
- Master of Science (MS) in Mathematics
- Master of Science (MS) in Plant Breeding
- Master of Science (MS) in Safety Engineering
- Master of Science (MS) in Special Education
- Master of Science (MS) in Sport Management
- Master of Science (MS) in Statistics
- Master of Science in Nursing (MSN) in Family Nurse Practitioner
- Master of Science in Nursing (MSN) in Forensic Nursing
- Master of Science in Nursing (MSN) in Nursing Education
- Master of Wildlife Science (MWSC) in Wildlife Science

A limited number of graduate certificate programs are available by distance education. Please review Transcribed Graduate Certificate Programs.

The delivery platform differs among these programs. Most are available 100% online, some are web-supported with interactive video and others require periodic campus visits. The delivery platform in most programs changes depending on the course/program content, needs of the students and their geographic locations. Students should carefully consider distance education and address any specific questions to the department offering the program of interest.

Only a student who is admitted to Texas A&M University may enroll in these distance education programs and the associated courses. A student wishing to enroll in any of the distance education programs must be admitted as a degree-seeking graduate student or as a post-baccalaureate non-degree seeking student. Please see <http://admissions.tamu.edu> for graduate admissions information.

A student may take up to 12 hours in non-degree-seeking post-baccalaureate status and apply these hours to a master's program with the approval of the student's advisory committee, the head of the department (or Chair of the Intercollegiate Faculty, if appropriate), and the Office of Graduate and Professional Studies if all admission requirements to the selected master's program are fulfilled. Courses offered for extension credit may not be used on the student's degree plan. Post-baccalaureate non-degree status does not establish eligibility for admission to degree-seeking status.

Texas A&M University provides students pursuing a graduate degree by distance a wide variety of student support services, including access to library resources, advising, technology support and course materials acquisition through the online bookstore. A complete listing of services, degree program descriptions, appropriate points of contact within each program, and costs are available through the distance education website at <http://distance.tamu.edu>. Additional distance education programs are in development. Interested students should check the website periodically for updates. Students should contact the department offering the program for any questions.

Graduate Certificate Programs

Transcribed Graduate Certificate Programs

- Advanced International Affairs Certificate (<http://catalog.tamu.edu/graduate/colleges-schools-interdisciplinary/government-public-service/international-affairs/advanced-certificate>)¹
- Advanced Pedagogy in Agriculture Certificate (<http://catalog.tamu.edu/graduate/colleges-schools-interdisciplinary/agriculture-life-sciences/agricultural-leadership-education-communications/advanced-pedagogy-agriculture-certificate>)
- Africana Studies Certificate (<http://catalog.tamu.edu/graduate/colleges-schools-interdisciplinary/liberal-arts/interdepartmental-degree-programs/africana-studies-certificate>)
- Agriculture eLearning Development Certificate (<http://catalog.tamu.edu/graduate/colleges-schools-interdisciplinary/agriculture-life-sciences/agricultural-leadership-education-communications/agriculture-elearning-development-certificate>)¹
- Applied Behavior Analysis Certificate (<http://catalog.tamu.edu/graduate/colleges-schools-interdisciplinary/education-human-development/educational-psychology/applied-behavior-analysis-certificate>)¹
- Applied Statistics Certificate (<http://catalog.tamu.edu/graduate/colleges-schools-interdisciplinary/science/statistics/applied-statistics-certificate>)¹
- Business Data Analytics Certificate (<http://catalog.tamu.edu/graduate/colleges-schools-interdisciplinary/business/interdepartmental/business-data-analytics-certificate>)
- Business Intelligence and Analytics Certificate (<http://catalog.tamu.edu/graduate/colleges-schools-interdisciplinary/business/information-operations-management/business-intelligence-analytics-certificate>)
- Business Management Certificate (<http://catalog.tamu.edu/graduate/colleges-schools-interdisciplinary/business/interdepartmental/business-management-certificate>)
- Community Development Certificate (<http://catalog.tamu.edu/graduate/colleges-schools-interdisciplinary/agriculture-life-sciences/recreation-park-tourism-sciences/community-development-certificate>)
- Computational Sciences Certificate (<http://catalog.tamu.edu/graduate/colleges-schools-interdisciplinary/engineering/computer-science/computational-sciences-certificate>)
- Conservation Training Certificate (<http://catalog.tamu.edu/graduate/colleges-schools-interdisciplinary/liberal-arts/anthropology/conservation-training-certificate>)
- Dietetic Internship Certificate (<http://catalog.tamu.edu/graduate/colleges-schools-interdisciplinary/agriculture-life-sciences/nutrition-food-science/dietetic-internship-certificate>)
- Digital Humanities Certificate (<http://catalog.tamu.edu/graduate/colleges-schools-interdisciplinary/interdisciplinary/digital-humanities-certificate>)
- Education for Health Care Professionals Certificate (<http://catalog.tamu.edu/graduate/colleges-schools-interdisciplinary/medicine/interdepartmental/education-healthcare-professionals-certificate>)¹
- Education and Social Sciences Advanced Research Methods (ARM) Certificate (<http://catalog.tamu.edu/graduate/colleges-schools-interdisciplinary/education-human-development/interdepartmental/education-social-sciences-arm-certificate>)
- Energy Certificate (<http://catalog.tamu.edu/graduate/colleges-schools-interdisciplinary/interdisciplinary/energy-certificate>)¹
- Energy Sustainability Engineering Certificate (<http://catalog.tamu.edu/graduate/colleges-schools-interdisciplinary/engineering/petroleum/energy-sustainability-engineering-certificate>)¹
- Engineering Therapeutics Manufacturing Certificate (<http://catalog.tamu.edu/graduate/colleges-schools-interdisciplinary/engineering/biomedical/engineering-therapeutics-manufacturing-certificate>)
- Entrepreneurship Certificate (<http://catalog.tamu.edu/graduate/colleges-schools-interdisciplinary/business/management/entrepreneurship-certificate>)
- Environmental Hazard Management Certificate (<http://catalog.tamu.edu/graduate/colleges-schools-interdisciplinary/architecture/environmental-hazard-management-certificate>)
- Extension Education Certificate (<http://catalog.tamu.edu/graduate/colleges-schools-interdisciplinary/agriculture-life-sciences/agricultural-leadership-education-communications/extension-education-certificate>)
- Facility Management Certificate (<http://catalog.tamu.edu/graduate/colleges-schools-interdisciplinary/architecture/facility-management-certificate>)
- Film and Media Studies Certificate (<http://catalog.tamu.edu/graduate/colleges-schools-interdisciplinary/liberal-arts/interdepartmental-degree-programs/film-media-studies-certificate>)
- Finance Certificate (<http://catalog.tamu.edu/graduate/colleges-schools-interdisciplinary/business/interdepartmental/finance-certificate>)
- Food Safety Certificate (<http://catalog.tamu.edu/graduate/colleges-schools-interdisciplinary/agriculture-life-sciences/animal-science/food-safety-certificate>)
- Forensic Healthcare Certificate (<http://catalog.tamu.edu/graduate/colleges-schools-interdisciplinary/nursing/forensic-healthcare-certificate>)¹
- Geographic Information Science (GIS) Certificate (<http://catalog.tamu.edu/graduate/colleges-schools-interdisciplinary/interdisciplinary/gis-certificate>)
- Health Coaching for Chronic Disease Prevention and Management Certificate (<http://catalog.tamu.edu/graduate/colleges-schools-interdisciplinary/public-health/health-promotion-community-health-sciences/health-coaching-chronic-disease-prevention-management-certificate>)

- Health Systems and Design Certificate (<http://catalog.tamu.edu/graduate/colleges-schools-interdisciplinary/interdisciplinary/health-systems-design-certificate>)
- Health Systems Management Certificate (<http://catalog.tamu.edu/graduate/colleges-schools-interdisciplinary/public-health/health-policy-management/health-systems-management-certificate>)
- Hispanic Bilingual Education Certificate (<http://catalog.tamu.edu/graduate/colleges-schools-interdisciplinary/education-human-development/educational-psychology/hispanic-bilingual-education-certificate>)¹
- Historic Preservation Certificate (<http://catalog.tamu.edu/graduate/colleges-schools-interdisciplinary/architecture/historic-preservation-certificate>)
- Homeland Security Certificate (<http://catalog.tamu.edu/graduate/colleges-schools-interdisciplinary/government-public-service/public-service-administration/homeland-security-certificate>)¹
- Industrial Data Analytics Certificate (<http://catalog.tamu.edu/graduate/colleges-schools-interdisciplinary/engineering/industrial-systems/industrial-data-analytics-certificate>)¹
- International Agriculture and Resource Management (IARM) Certificate (<http://catalog.tamu.edu/graduate/colleges-schools-interdisciplinary/agriculture-life-sciences/interdepartmental/iarm-certificate>)
- International Business (Mays MBA Students Only) Certificate (<http://catalog.tamu.edu/graduate/colleges-schools-interdisciplinary/business/interdepartmental/international-business-certificate-mba>)
- International Business (Mays MS Students Only) Certificate (<http://catalog.tamu.edu/graduate/colleges-schools-interdisciplinary/business/interdepartmental/international-business-certificate-ms>)
- International Communication and Public Diplomacy Certificate (<http://catalog.tamu.edu/graduate/colleges-schools-interdisciplinary/liberal-arts/communication/international-communication-public-diplomacy-certificate>)
- International Education Certificate (<http://catalog.tamu.edu/graduate/colleges-schools-interdisciplinary/education-human-development/interdepartmental/international-education-certificate>)
- International Petroleum Management Certificate (<http://catalog.tamu.edu/graduate/colleges-schools-interdisciplinary/interdisciplinary/international-petroleum-management-certificate>)
- Latino/a and Mexican American Studies Certificate (<http://catalog.tamu.edu/graduate/colleges-schools-interdisciplinary/liberal-arts/interdepartmental-degree-programs/latino-and-mexican-american-studies-certificate>)
- Leadership Education, Theory and Practice Certificate (<http://catalog.tamu.edu/graduate/colleges-schools-interdisciplinary/agriculture-life-sciences/agricultural-leadership-education-communications/leadership-education-theory-practice-certificate>)
- Marketing Certificate (<http://catalog.tamu.edu/graduate/colleges-schools-interdisciplinary/business/interdepartmental/marketing-certificate>)
- Meat Science Certificate (<http://catalog.tamu.edu/graduate/colleges-schools-interdisciplinary/agriculture-life-sciences/animal-science/meat-science-certificate>)
- Military Land Sustainability Certificate (<http://catalog.tamu.edu/graduate/colleges-schools-interdisciplinary/agriculture-life-sciences/interdepartmental/military-land-sustainability-certificate>)¹
- National Security Affairs Certificate (<http://catalog.tamu.edu/graduate/colleges-schools-interdisciplinary/government-public-service/interdepartmental/national-security-affairs-certificate>)¹
- Nonprofit Management Certificate (<http://catalog.tamu.edu/graduate/colleges-schools-interdisciplinary/government-public-service/public-service-administration/nonprofit-management-certificate>)¹
- Nuclear Security Certificate (<http://catalog.tamu.edu/graduate/colleges-schools-interdisciplinary/engineering/nuclear/nuclear-engineering-certificate>)
- Ocean Observing Systems Certificate (<http://catalog.tamu.edu/graduate/colleges-schools-interdisciplinary/geosciences/oceanography/ocean-observing-systems-certificate>)
- Petroleum Geoscience Certificate (<http://catalog.tamu.edu/graduate/colleges-schools-interdisciplinary/geosciences/geology-geophysics/petroleum-geoscience-certificate>)
- Prevention Science Certificate (<http://catalog.tamu.edu/graduate/colleges-schools-interdisciplinary/interdisciplinary/prevention-science-certificate>)
- Public Health Certificate (<http://catalog.tamu.edu/graduate/colleges-schools-interdisciplinary/public-health/interdepartmental/public-health-certificate>)¹
- Public Management Certificate (<http://catalog.tamu.edu/graduate/colleges-schools-interdisciplinary/government-public-service/public-service-administration/public-management-certificate>)¹
- Quality Engineering for Regulated Medical Technologies Certificate (<http://catalog.tamu.edu/graduate/colleges-schools-interdisciplinary/engineering/biomedical/quality-engineering-regulated-medical-technologies-certificate>)
- Regulatory Science in Food Systems Certificate (<http://catalog.tamu.edu/graduate/colleges-schools-interdisciplinary/agriculture-life-sciences/soil-crop-sciences/regulatory-science-food-systems-certificate>)¹
- Remote Sensing (RS) Certificate (<http://catalog.tamu.edu/graduate/colleges-schools-interdisciplinary/interdisciplinary/rs-certificate>)
- Safety Engineering Certificate (<http://catalog.tamu.edu/graduate/colleges-schools-interdisciplinary/engineering/interdepartmental-degree-programs/safety-engineering-certificate>)¹
- Science, Technology, Engineering and Mathematics (STEM) Education Certificate (<http://catalog.tamu.edu/graduate/colleges-schools-interdisciplinary/education-human-development/teaching-learning-culture/science-technology-engineering-mathematics-education-certificate>)
- Space Life Sciences (<http://catalog.tamu.edu/graduate/colleges-schools-interdisciplinary/interdisciplinary/space-life-sciences-certificate>)
- Supply Chain and Operations Certificate (<http://catalog.tamu.edu/graduate/colleges-schools-interdisciplinary/business/interdepartmental/supply-chain-operations-certificate>)
- Supply Chain Management (Mays MBA and MS Students Only) Certificate (<http://catalog.tamu.edu/graduate/colleges-schools-interdisciplinary/business/information-operations-management/supply-chain-management-certificate>)
- Sustainable Urbanism Certificate (<http://catalog.tamu.edu/graduate/colleges-schools-interdisciplinary/architecture/landscape-architecture-urban-planning/sustainable-urbanism-certificate>)

- Transportation Planning Certificate (<http://catalog.tamu.edu/graduate/colleges-schools-interdisciplinary/interdisciplinary/transportation-planning-certificate>)
- Women's and Gender Studies Certificate (<http://catalog.tamu.edu/graduate/colleges-schools-interdisciplinary/liberal-arts/interdepartmental-degree-programs/womens-gender-studies-certificate>)

Graduate Clinical Certificate Programs

- Advanced Education in General Dentistry Certificate (<http://catalog.tamu.edu/graduate/colleges-schools-interdisciplinary/dentistry/general-dentistry/advanced-education-certificate>)
- Dental Public Health Certificate (<http://catalog.tamu.edu/graduate/colleges-schools-interdisciplinary/dentistry/public-health-sciences/dental-public-health-certificate>)
- Endodontics Certificate (<http://catalog.tamu.edu/graduate/colleges-schools-interdisciplinary/dentistry/endodontics/endodontics-certificate>)
- Oral and Maxillofacial Surgery Certificate (<http://catalog.tamu.edu/graduate/colleges-schools-interdisciplinary/dentistry/oral-maxillofacial-surgery/maxillofacial-surgery-certificate>)
- Oral and Maxillofacial Pathology Certificate (<http://catalog.tamu.edu/graduate/colleges-schools-interdisciplinary/dentistry/diagnostic-sciences/oral-maxillofacial-pathology-certificate>)
- Oral and Maxillofacial Radiology Certificate (<http://catalog.tamu.edu/graduate/colleges-schools-interdisciplinary/dentistry/diagnostic-sciences/oral-maxillofacial-radiology-certificate>)
- Orthodontics Certificate (<http://catalog.tamu.edu/graduate/colleges-schools-interdisciplinary/dentistry/orthodontics/orthodontics-certificate>)
- Pediatric Dentistry Certificate (<http://catalog.tamu.edu/graduate/colleges-schools-interdisciplinary/dentistry/pediatric-dentistry/pediatric-dentistry-certificate>)
- Periodontics Certificate (<http://catalog.tamu.edu/graduate/colleges-schools-interdisciplinary/dentistry/periodontics/periodontics-certificate>)
- Prosthodontics Certificate (<http://catalog.tamu.edu/graduate/colleges-schools-interdisciplinary/dentistry/restorative-sciences/prosthodontics-certificate>)

¹ Also offered via online Distance Education.

A graduate certification program represents an emphasis area within a particular field or it could be interdisciplinary and involve several fields. Other certificate programs may exist in the various colleges or schools. Inquiries should be addressed to these colleges. For more information on graduate certificate programs, please visit the Office of the Registrar (<http://registrar.tamu.edu/Our-Services/Curricular-Services/Curricular-Approvals/Program-Approvals/Approved-Certificate-Programs>) website.



**TEXAS DEPARTMENT OF
HOUSING & COMMUNITY AFFAIRS**
Building Homes. Strengthening Communities.

TAB 11

Site Information Form (Part III)

Site Information Form Part III

Self Score Total: 35

1. Site Acreage

Please identify site acreage as listed in each of the following exhibits/documents.

Site Control: 4 Site Plan: 4 Appraisal: ESA: 6.1

(*) Should equal acreage indicated in site control documents less acreage intended to be dedicated, sold or used for public purpose and not to be encumbered by LURA (net acreage). The net acreage will be used for calculating density for all purposes.

Please provide an explanation of any discrepancies in site acreage below:

The ESA refers to the acres of the entire tract the lease is just for a 4ac portion of the tract

2. Site Control - §10.204(10)

The current owner of the Development Site is (If scattered site & more than one owner refer to Tab 13):

John Hale & Ola Kay Hale

Entity Name

Contact Name

P.O. Box 188

Address

North Zulch

TX

77872

7/19/1991

City

State

Zip

Date of Last Sale

Is the seller affiliated with the Applicant, Principal, sponsor, or any Development Team member?

No

If "Yes," please explain:

Did the seller acquire the property through foreclosure or deed in lieu of foreclosure?

No

Identify all of the sellers of the proposed property for the 36 months prior to the first day of the Application Acceptance Period and their relationship, if any, to members of the Development Team:

Name:

Relationship:

Site Control is in the form of:

Contract for sale.

Recorded Warranty Deed with corresponding executed closing/settlement statement.

Contract for lease.

Expiration of Contract or Option: 12/31/2115

Anticipated Closing Date:

Title Commitment or Title Policy is included behind this tab (per §10.204(12)).

3. **Site Control - §10.204(10)**

Ingress/Egress and Easements (9% and 4% HTC Only) - §11.7

Is land for ingress and/or egress and any easements held separate from the property described in the site control documents?

If yes, describe how any such land is held. Identify the land owner and describe any agreements the Applicant has or will enter into with the land owner.

4. **30% increase in Eligible Basis "Boost" (9% and 4% HTC Only) - §11.4(c)**

Development qualifies for the boost for:

- Qualified Census tract that has less than 20% HTC Units per household
- Development is located in a Small Area Difficult Development Area (SADDA)
- Rural Development (**Competitive HTC only**)
- X Development is entirely Supportive Housing (**Competitive HTC Only**)
- X Development meets the criteria for the Opportunity Index as identified in §11.9(c)(4) of the Qualified Allocation Plan (**Competitive HTC only**)
- Development is in an area covered by a concerted revitalization plan and elects and is eligible for points under §11.9(d)(7), is not Elderly, and is not located in a QCT. (**Competitive HTC only**)
- Development includes an additional 10% of units at 30% AMI. *Must be in addition to the number of units needed for any scoring item or any other funding source from MF Direct Loan requirements. (Competitive HTC only)*
- Development is in a QCT with 20% or greater Housing Tax Credit Units per household, and a resolution from the Governing Body of the appropriate municipality or county allowing the construction of the Development is included behind Tab 8**

** Resolution not due until Resolutions Delivery Date for Tax-Exempt Bond Developments

If a revised form is submitted, date of submission:



TEXAS DEPARTMENT OF
HOUSING & COMMUNITY AFFAIRS
Building Homes. Strengthening Communities.

TAB 12

Supporting Documentation from Site Information (Part III)

Support Documentation from Site Information Part III Should be Included Behind this Tab.

- Site Control Documentation
- Title Commitment or Policy
- Each of the Direct Loan exhibits identified below (as applicable)



Increase in Eligible Basis (30% Boost)

- Resolution from the Governing Body of the appropriate municipality or county allowing the construction of the Development, if applicable.
- Census tract map that includes the 11-digit census tract number and clearly shows that the proposed Development is located within a QCT, if applicable
- SADDA map clearly showing the Development is located within the boundaries of a SADDA, if applicable



Site & Neighborhood Standards (New Construction Direct Loan only)

Confirm the following supporting documents are provided behind this tab.

- Letters on company letterhead from local utility providers confirming the site has access to the following services: water and wastewater/sewer, electricity, garbage disposal and natural gas, if applicable.
- Statement explaining how the Development will promote greater choice of housing opportunities and avoid undue concentration of assisted persons in areas containing a high proportion of low-income persons.
- DP-1 Profile of General Demographic Characteristics (2010) Census data for the census tract and city (and county if proposed site is located in a rural area) where the proposed site will be located. DP-1 Census data can be accessed using the Advanced Search option at www.census.gov.
- A statement confirming that travel time and cost via public transportation or private automobile, from the neighborhood to places of employment providing a range of jobs for lower-income workers, is not excessive. This is not applicable for Developments proposing to serve Elderly.



GROUND LEASE

This Lease is entered into on _____ [date], Brazos Valley Community Church of God, Inc. ("Landlord"), whose address is P.O. Box 1296 Bryan, Texas 77806, and No Limits International Development Corp ("Tenant"), whose address is 2002 Hwy 21 E., Bryan, Texas 77803.

ARTICLE 1. DEMISE OF LEASED PREMISES

In consideration of the mutual covenants and agreements of this lease, and other good and valuable consideration, Landlord demises and leases to Tenant, and Tenant leases from Landlord, the premises in Bryan, Brazos County, Texas, depicted by cross-hatching on Exhibit "A" attached to this lease, and made a part of this lease, for all purposes (collectively referred to as "the premises" or "the leased premises" in this lease) and consisting of 4 acre to be surveyed out of the 6.1 acres reflected on Exhibit A.

Tenant is to have and to hold the premises, together with all rights, privileges, easements, appurtenances, and immunities belonging to or in any way appertaining to them.

ARTICLE 2. LEASE TERM

Fixed Beginning and Termination Date

§ 2.01. The term of this lease is 99 years, beginning on January 1, 2017, and ending on December 31, 2115, unless terminating sooner as provided in this lease.

Termination

§ 2.03. This lease will terminate without further notice when the term specified in § 2.01 expires, and any holding over by Tenant after that term expires, other than as provided in § 2.02, will not constitute a renewal of the lease or give Tenant any rights under the lease in or to the premises.

Holdover

§ 2.05. If Tenant holds over and continues in possession of the premises after the lease term (or any extension) expires, other than as provided in § 2.02, Tenant will be considered to be occupying the premises at will, subject to all the terms of this lease.

ARTICLE 3. RENT

Minimum Yearly Rent

§ 3.01. Tenant will pay Landlord \$1.00 per year during the term of this lease as annual rent for using and occupying the premises.

Time and Manner of Payment

§ 3.02. Tenant will pay all rent due under this article on an annual basis. Such annual rent is due and payable in one annual monthly installment, on the first calendar day of the year. Payments must be in lawful money of the United States to the Landlord.

ARTICLE 4. UTILITIES

Tenant will pay or cause to be paid all charges, if any, for water, heat, gas, electricity, sewers, and all other utilities used on the premises, if any, throughout the lease term, including any connection fees.

**ARTICLE 5.
USE OF PREMISES**

Permitted and Prohibited Use of Premises

§ 5.01. Tenant may use the premises for the purpose of constructing a Community Center on the Property and surrounding parking lot.

Prohibited Use of Premises

§ 5.02. Under no circumstances during the term of this lease will Tenant use or cause to be used in the business operated on the premises any hazardous or toxic substances or materials, or store or dispose of any such substances or materials on the premises.

Illegal Use Not Permitted

§ 5.03. Tenant may not use all or any part of the premises or any building situated on them for any use or purpose that violates any valid and applicable law, regulation, or ordinance of the United States, the State of Texas, the County of Brazos, Bryan, Texas, or other lawful authority with jurisdiction over the premises. Tenant is not considered to have violated this provision unless:

- a. Landlord has notified Tenant in a writing specifying the alleged violation;
- b. There has been a final adjudication by a court of competent jurisdiction that the specified use violates the law, regulation, or ordinance specified in the notice;
- c. The specified law, regulation, or ordinance is valid and applies to the premises; and
- d. Tenant has had a reasonable time after the final adjudication to cure the specified violation.

**ARTICLE 6.
CONSTRUCTION BY TENANT**

General Conditions

§ 6.01. Tenant may, at any time and from time to time during the lease term, construct the Community Center and maintain said improvements including a parking lot consisting of parking spaces, driveways, etc., and correct and change the contour of the premises, subject to the following:

- a. Tenant bears the cost of any such work.
- b. The premises must at all times be kept free of mechanics' and materialmen's liens.

Ownership of Improvements

§ 6.02. Any improvements, additions, and alterations constructed, placed, or maintained on any part of the leased premises during the lease term are considered part of the real property of the premises and must remain on the premises and become Landlord's property when the lease terminates.

**ARTICLE 7.
ENCUMBRANCE OF LEASEHOLD ESTATE**

Tenant shall not have the Right to Encumber

Tenant may not, at any time, encumber the leasehold interest, by deed of trust, mortgage, or other security instrument.

**ARTICLE 8.
REPAIRS, MAINTENANCE, AND RESTORATION**

Tenant's Duty to Maintain and Repair

At all times during the lease term, Tenant will keep and maintain, or cause to be kept and maintained, all improvements erected on the premises in a good state of appearance and repair (except for reasonable wear and tear) at Tenant's own expense.

**ARTICLE 9.
MECHANICS' LIENS**

Tenant will not cause or permit any mechanics' liens or other liens to be filed against the fee of the premises or against Tenant's leasehold interest (excluding any leasehold mortgage) in the land or any buildings or improvements on the premises by reason of any work, labor, services, or materials supplied or claimed to have been supplied to Tenant or anyone holding the premises or any part of them through or under Tenant. If such a mechanic's lien or materialman's lien is recorded against the premises or any buildings or improvements on them, Tenant must either cause it to be removed or, if Tenant in good faith wishes to contest the lien, take timely action to do so, at Tenant's sole expense. If Tenant contests the lien, Tenant will indemnify Landlord and hold it harmless from all liability for damages occasioned by the lien or the lien contest and will, in the event of a judgment of foreclosure on the lien, cause the lien to be discharged and removed before the judgment is executed.

**ARTICLE 10.
INDEMNIFICATION**

Landlord is not liable for any loss, damage, or injury of any kind to any person or property arising from any use of the premises (or any part of them), or caused by any defect in any structure, improvement, or facility on the premises or caused by or arising from any act or omission of Tenant, or of any of its agents, employees, licensees, or invitees, or by or from any accident, fire, or other casualty on the land, or brought about by Tenant's failure to maintain the premises in safe condition.

**ARTICLE 11.
ASSIGNMENT AND SUBLEASE**

Tenant may assign its leasehold estate in its entirety or any portion of it if it sells its adjacent property known as Primrose Schools Franchising Company, or may sublet the premises or any portion of them or any portion of any building or other improvement erected on the premises, at any time and from time to time, and the rights of Tenant or its successor or assignee, may pass by operation of law. But each such transfer, assignment, or sale is subject to Tenant's obligations to Landlord under this lease and will not release Tenant from its obligations under this lease.

**ARTICLE 12.
DEFAULT AND REMEDIES**

Termination on Default

§ 13.01. If Tenant defaults in performing any covenant or term of this lease and does not correct the default within 30 after receipt of written notice from Landlord to Tenant and any lender as required by § 8.02, Landlord may declare this lease, and all rights and interest created by it, terminated. If Landlord elects to terminate, this lease will cease as if the day of Landlord's election were the day originally fixed in the lease for its expiration. Landlord or its agent or attorney may resume possession of the premises and relet them for the remainder of the term at the best rent obtainable for the account of Tenant, who must make good any deficiency.

Other Remedies

§ 13.02. Any termination of this lease as provided in this article will not relieve Tenant from paying any sum or sums due and payable to Landlord under the lease at the time of termination, or any claim for damages then or

previously accruing against Tenant under this lease. Any such termination will not prevent Landlord from enforcing the payment of any such sum or sums or claim for damages by any remedy provided for by law, or from recovering damages from Tenant for any default under the lease. All Landlord's rights, options, and remedies under this lease will be construed to be cumulative, and no one of them is exclusive of the other. Landlord may pursue any or all such remedies or any other remedy or relief provided by law, whether or not stated in this lease. No waiver by Landlord of a breach of any of the covenants or conditions of this lease may be construed a waiver of any succeeding or preceding breach of the same or any other covenant or condition of this lease.

ARTICLE 13.
LANDLORD'S WARRANTIES AND COVENANTS

Warranty of Title

§ 14.01. Landlord warrants that it is the owner in fee simple absolute of the premises, subject only to the following covenants, conditions, easements, and other matters of record: none known.

Warranty of Quiet Enjoyment

§ 14.02. Landlord covenants that as long as Tenant pays the rent and other charges under this lease and observes the covenants and terms of this lease, Tenant will lawfully and quietly hold, occupy, and enjoy the premises during the lease term without being disturbed by Landlord or any person claiming under Landlord, except for any portion of the premises that is taken under the power of eminent domain.

ARTICLE 14.
GENERAL PROTECTIVE PROVISIONS

No Partnership or Joint Venture

§ 15.01. The relationship between Landlord and Tenant is at all times solely that of landlord and tenant and may not be deemed a partnership or a joint venture.

Force Majeure

§ 15.02. If curing any default (other than failure to pay rent, insurance premiums, or ad valorem taxes) or performing any other covenant or term is delayed by reason of war, civil commotion, act of God, governmental restrictions, regulations, or interference, fire or other casualty, or any other circumstances beyond Tenant's control or that of the party obligated or permitted under this lease to do or perform the term or covenant, regardless of whether the circumstance is similar to any of those enumerated or not, each party so delayed is excused from performance during the delay period.

No Termination on Bankruptcy

§ 15.03. Bankruptcy, insolvency, assignment for the benefit of creditors, or the appointment of a receiver will not affect this lease as long as Tenant and Landlord or their respective successors or legal representatives continue to perform all covenants of this lease.

No Waiver

§ 15.04. No waiver by either party of any default or breach of any covenant or term of this lease may be treated as a waiver of any subsequent default or breach of the same or any other covenant or term of this lease.

Joint and Several Liability

§ 15.05. If this lease names more than one Tenant or Landlord, the obligation of all such Tenants or Landlords is joint and several.

**ARTICLE 15.
MISCELLANEOUS**

Delivery of Rents and Notices

§ 16.01. All rents or other sums, notices, demands, or requests from one party to another may be personally delivered or sent by mail, certified or registered, postage prepaid, to the addresses stated in this section and are considered to have been given at the time of personal delivery or of mailing. All payments, notices, demands, or requests from Tenant to Landlord should be mailed to Landlord at 3501 S. Texas Avenue, Suite 300, Bryan, Texas 77803, or at such other address or fax number as Landlord requests in writing.

All payments, notices, demands, or requests from Landlord to Tenant should be mailed to Tenant at 1021 Arrington Road, College Station, Texas 77845, or at such other address or fax number as Tenant requests in writing.

Multiple Parties

§ 16.02. If this lease names more than one Landlord or Tenant, service of any notice on any one Tenant or Landlord is considered service on all Tenants or Landlords, respectively.

Parties Bound

§ 16.03. This agreement binds, and inures to the benefit of, the parties to the lease and their respective heirs, executors, administrators, legal representatives, successors, and assigns.

Texas Law to Apply

§ 16.04. This agreement is to be construed under Texas law, and all obligations of the parties created by this lease are performable in Brazos County, Texas.

Legal Construction

§ 16.05. If any one or more of the provisions contained in this agreement are for any reason held to be invalid, illegal, or unenforceable in any respect, the invalidity, illegality, or unenforceability will not affect any other provision of the lease, which will be construed as if it had not included the invalid, illegal, or unenforceable provision.

Prior Agreements Superseded

§ 16.06. This agreement constitutes the parties' sole agreement and supersedes any prior understandings or written or oral agreements between the parties with respect to the subject matter.

Amendment

§ 16.07. No amendment, modification, or alteration of this lease is binding unless in writing, dated subsequent to the date of this lease, and duly executed by the parties.

Rights and Remedies Cumulative

§ 16.08. The rights and remedies provided by this lease agreement are cumulative, and either party's using any right or remedy will not preclude or waive its right to use any other remedy. The rights and remedies are given in addition to any other rights the parties may have by law, statute, ordinance, or otherwise.

Attorney's Fees and Costs

§ 16.09. If, as a result of either party's breaching this agreement, the other party employs an attorney to enforce its rights under this lease, then the breaching or defaulting party will pay the other party the reasonable attorney's fees and costs incurred to enforce the lease.

Time of Essence

§ 16.10. Time is of the essence of this agreement.

Further Documents

§ 16.11. Landlord will from time to time and at any reasonable time execute and deliver to Tenant, when Tenant reasonably requests, other instruments and assurances approving, ratifying, and confirming this lease and the leasehold estate created by it and certifying that the lease is in full force and that no default under the lease on Tenant's part exists. But if any default on Tenant's part does exist, Landlord must specify in any such instrument each such default.

(SIGNATURES APPEARING ON NEXT PAGE)

THIS LEASE has been executed by the parties on the date and year first above written.

LANDLORD

BRAZOS VALLEY COMMUNITY CHURCH OF GOD, INC

By:

Ozell Roberts

Ozell Roberts

President

Date: 12-30-2016

Kiffany Pool

Kiffany Pool

Secretary

Date: 12-30-2016

TENANT

**NO LIMITS INTERNATIONAL ECONOMIC
DEVELOPMENT CORP**

By:

Wamen Roberts *President*

(Name)

(Title)

Date: 12-30-2016

COMMITMENT FOR TITLE INSURANCE T-7

ISSUED BY

COMMONWEALTH LAND TITLE INSURANCE COMPANY

SCHEDULE A

GF No. 36089

Effective Date: February 20, 2017, 07:00 am

Commitment issued February 24, 2017, 05:00 pm

1. The policy or policies to be issued are:

- a. **OWNER'S POLICY OF TITLE INSURANCE (Form T-1)**
(Not applicable for improved one-to-four family residential real estate)
Policy Amount: \$1,000,000.00
PROPOSED INSURED: No Limits International Economic Development Corp
- b. **TEXAS RESIDENTIAL OWNER'S POLICY OF TITLE INSURANCE**
ONE-TO-FOUR FAMILY RESIDENCES (Form T-1R)
Policy Amount:
PROPOSED INSURED:
- c. **LOAN POLICY OF TITLE INSURANCE (Form T-2)**
Policy Amount:
PROPOSED INSURED:
Proposed Borrower:
- d. **TEXAS SHORT FORM RESIDENTIAL LOAN POLICY OF TITLE INSURANCE (Form T-2R)**
Policy Amount:
PROPOSED INSURED:
Proposed Borrower:
- e. **LOAN TITLE POLICY BINDER ON INTERIM CONSTRUCTION LOAN (Form T-13)**
Binder Amount:
PROPOSED INSURED:
Proposed Borrower:
- f. **OTHER**
Policy Amount:
PROPOSED INSURED:

2. The interest in the land covered by this Commitment is: Fee Simple

3. Record title to the land on the Effective Date appears to be vested in:
John W. Hale and Ola Kay Hale

4. Legal description of land:
SEE ATTACHED EXHIBIT "A"

Continuation of Schedule A

EXHIBIT "A"

All that certain tract or parcel of land lying and being situated in the STEPHEN F. AUSTIN No. 10 LEAGUE, ABSTRACT No. 63, City of Bryan, Brazos County, Texas. Said tract being all of a called 4.99 acre tract of land as described by a deed to John W. Hale and Wife, Ola Kay Hale recorded in Volume 1299, page 128 of the Official Public Records of Brazos County, Texas. Said 4.99 acre tract being a portion of Lot R1, Block 14, Revised plat of CHATHAM NORTHEAST SUBDIVISION according to the plat recorded in Volume 144, page 613 of the Deed Records of Brazos County, Texas.

Said tract being more particularly described by metes and bounds as follows:

BEGINNING at a 1/2 inch iron rod found (N:10237010.56, E:3542276.12) on the northwest line of State Highway 21 (100' R.O.W.) and the southwest line of Calhoun Street (50' R.O.W.). Said iron rod found marking the east corner of said Lot R1. Coordinates and bearing system shown herein are NAD83 (Texas State Plane Central Zone Grid North) based on the published coordinates of the City of Bryan Control Monument GPS-118 (N:10237315.64, E:3542837.12) and as established by GPS observation;

THENCE: S 52° 44' 53" W along the northwest line of State Highway No. 21 for a distance of 175.51 feet (Deed Call: S 52° 45' 25" W - 175.49 feet, 1299/128) to a 1/2 inch iron rod found marking the east corner of a called 6.16 acre tract of land as described by a deed to Bryan Church of God recorded in Volume 587, page 388 of the Deed Records of Brazos County, Texas;

THENCE: N 47° 38' 55" W along the northeast line of said 6.16 acre tract for a distance of 870.07 feet (Deed Call: N 47° 40' 00" W - 870.08 feet, 1299/128) to a 1/2 inch iron rod found marking the south corner of a called 1.194 acre tract of land as described by a deed to James Vavra and Marie Vavra recorded in Volume 10934, page 277 of the Official Public Records of Brazos County, Texas;

THENCE: N 52° 45' 28" E along the southeast line of the said 1.194 acre tract for a distance of 332.74 feet (Deed Call: N 52° 45' 25" E - 332.91 feet, 1299/128) to a 1/2 inch iron rod found on the southwest line of Calhoun Street;

THENCE: S 37° 14' 15" E along the southwest line of Calhoun Street for a distance of 855.73 feet (Deed Call: S 37° 14' 35" E - 855.72 feet, 1299/128) to the POINT OF BEGINNING containing 4.992 acres of land, more or less, as surveyed on the ground February, 2017. See plat prepared February, 2017, for more descriptive information. Distances shown herein are grid distances. To determine surface distances multiply by a combined scale factor of 1.000099975483388 (calculated using GEOID 12A).

Note: The Company is prohibited from insuring the area or quantity of the land described herein. Any statement in the above legal description of the area of land is not a representation that such area or quantity is correct, but is made only for informational and/or identification purposes and does not override Item No. 2 of Schedule B.

COMMITMENT FOR TITLE INSURANCE T-7

ISSUED BY

COMMONWEALTH LAND TITLE INSURANCE COMPANY

SCHEDULE B

EXCEPTIONS FROM COVERAGE

In addition to the Exclusions and Conditions and Stipulations, your Policy will not cover loss, costs, attorney's fees, and expenses resulting from:

1. ~~The following restrictive covenants of record itemized below (We must either insert specific recording data or delete this exception):~~
2. Any discrepancies, conflicts, or shortages in area or boundary lines, or any encroachments or protrusions, or any overlapping of improvements. **Company has approved the current land title survey and upon request, and payment of any promulgated premium, this item will be amended in the policy(ies) to be issued to read: 'shortages in area'.**
3. Homestead or community property or survivorship rights, if any of any spouse of any insured. (Applies to the Owner's Policy only.)
4. Any titles or rights asserted by anyone, including, but not limited to, persons, the public, corporations, governments or other entities,
 - a. to tidelands, or lands comprising the shores or beds of navigable or perennial rivers and streams, lakes, bays, gulfs or oceans, or
 - b. to lands beyond the line of the harbor or bulkhead lines as established or changed by any government, or
 - c. to filled-in lands, or artificial islands, or
 - d. to statutory water rights, including riparian rights, or
 - e. to the area extending from the line of mean low tide to the line of vegetation, or the rights of access to that area or easement along and across that area.(Applies to the Owner's Policy only.)
5. Standby fees, taxes and assessments by any taxing authority for the year 2016, and subsequent years; and subsequent taxes and assessments by any taxing authority for prior years due to change in land usage or ownership, but not those taxes or assessments for prior years because of an exemption granted to a previous owner of the property under Section 11.13, Texas Tax Code, or because of improvements not assessed for a previous tax year. (If Texas Short Form Residential Loan Policy of Title Insurance (T-2R) is issued, that policy will substitute "which become due and payable subsequent to Date of Policy" in lieu of "for the year ____ and subsequent years.")
6. The terms and conditions of the documents creating your interest in the land.
7. Materials furnished or labor performed in connection with planned construction before signing and delivering the lien document described in Schedule A, if the land is part of the homestead of the owner. (Applies to the Loan Title Policy Binder on Interim Construction Loan only, and may be deleted if satisfactory evidence is furnished to us before a binder is issued.)
8. Liens and leases that affect the title to the land, but that are subordinate to the lien of the insured mortgage. (Applies to Loan Policy (T-2) only.)
9. The Exceptions from Coverage and Express Insurance in Schedule B of the Texas Short Form Residential Loan Policy of Title Insurance (T-2R). (Applies to Texas Short Form Residential Loan Policy of Title Insurance (T-2R) only.) Separate exceptions 1 through 8 of this Schedule B do not apply to the Texas Short Form Residential Loan Policy of Title Insurance (T-2R).

Continuation of Schedule B

10. The following matters and all terms of the documents creating or offering evidence of the matters (We must insert matters or delete this exception.):
- a. The Company assumes no liability for reason of the following matter(s) shown on survey dated February 21, 2017, prepared by Brad Kerr, RPLS No. 4502:
 - a) fence does not follow property line(s)
 - b) aerial electric line not located in utility easement(s)
 - b. This policy covers only the land described in Schedule A, and does not insure title to any personal property, including the Manufactured Housing Unit(s), mobile home(s) and/or trailer(s) located on the herein described property. No portion of the policy amount includes the value of the Manufactured Housing Unit(s), mobile home(s) and/or trailer(s). The coverage of this policy does not extend to any lien on such Manufactured Housing Unit, mobile home(s) and/or trailer(s) or to any consequences of foreclosure or attempted foreclosure of any such lien
 - c. Easements and Building Setback Lines as shown or noted on revised plat recorded in Volume 144, page 613, Deed Records of Brazos County, Texas.
 - d. Mineral Deed executed by Spartan Drilling, Inc., a Texas corporation to 21 Oil & Gas Inc., a Texas corporation, dated March 6, 1986 and recorded in Volume 869, page 644, Official Public Records of Brazos County, Texas. Title to said interest has not been investigated subsequent to the aforesaid instrument.
 - e. Mineral and Royalty Deed executed by First City, Texas - Bryan, N.A. formerly known as First City National Bank of Bryan, Texas, as successor in interest to City National Bank of Bryan, Texas to William P. Martindale, dated May 31, 1989 and recorded in Volume 1120, page 231, Official Public Records of Brazos County, Texas. Title to said interest has not been investigated subsequent to the aforesaid instrument.
 - f. Estate created by oil, gas and mineral lease granted to MCZ, Inc. by Spartan Drilling, Inc. by instrument dated May 13, 1981, recorded in Volume 39, page 216, Oil, Gas and Mineral Lease Records of Brazos County, Texas, and all terms, conditions and stipulations contained therein. Title to this lease has not been investigated subsequent to date thereof.
 - g. Rights of Tenants, as tenants only, under terms and conditions contained in any unrecorded leases.
 - h. Rights of parties in possession.

COMMITMENT FOR TITLE INSURANCE T-7

ISSUED BY

COMMONWEALTH LAND TITLE INSURANCE COMPANY

SCHEDULE C

Your Policy will not cover loss, costs, attorneys' fees, and expenses resulting from the following requirements that will appear as Exceptions in Schedule B of the Policy, unless you dispose of these matters to our satisfaction, before the date the Policy is issued:

1. Documents creating your title or interest must be approved by us and must be signed, notarized and filed for record.
2. Satisfactory evidence must be provided that:
 - a. no person occupying the land claims any interest in that land against the persons named in paragraph 3 of Schedule A,
 - b. all standby fees, taxes, assessments and charges against the property have been paid,
 - c. all improvements or repairs to the property are completed and accepted by the owner, and that all contractors, sub-contractors, laborers and suppliers have been fully paid, and that no mechanic's, laborer's or materialmen's liens have attached to the property,
 - d. there is legal right of access to and from the land,
 - e. (on a Loan Policy only) restrictions have not been and will not be violated that affect the validity and priority of the insured mortgage.
3. You must pay the seller or borrower the agreed amount for your property or interest.
4. Any defect, lien or other matter that may affect title to the land or interest insured, that arises or is filed after the effective date of this Commitment.
5. We require from No Limits International Economic Development Corporation the following documents for examination and possible additional requirements: 1) Certificate of Incorporation; 2) Certificate of Good Standing; 3) Copy of Articles of Incorporation; 4) Copy of By-Laws; and, 5) Corporate Resolution indicating authority and identity of person(s) representing said company in this transaction.
6. If we are to include coverage for a mobile home or manufactured housing unit situated upon the herein described property, we require the following:
 1. The seller must obtain, in their own name, an SOL having designated the subject MHU as real property prior to closing the transaction.
 2. The real property status must be perfected by filing a certified copy of the SOL in the real property records in Brazos County. A copy of the filed instrument must be returned to TDHCA.
 3. Copies of the recorded SOL must be sent to the Tax Assessor-Collector for the property. The MHU must be removed from the personal property tax roll and added to the real property tax roll as an improvement to the land.
 4. All personal property taxes due at the time of designating the property as real property must be paid to the Tax Assessor-Collector.

The above items **MUST BE** completed **PRIOR TO CLOSING**.
7. We reserve the right to search buyer name in the real property records and make additional requirements, if any, in the event that the contract for sale is assigned.

Continuation of Schedule C

NOTE: We find no outstanding voluntary liens of record affecting the subject property. Inquiry should be made concerning the existence of any recorded or unrecorded lien or other indebtedness which could give rise to any security interest claim in the subject property.

Countersigned
Aggieland Title Company

By *[Handwritten Signature]*

**COMMITMENT FOR TITLE INSURANCE T-7
SCHEDULE D**

Effective Date: February 20, 2017, 07:00 am

GF No. 36089

Pursuant to the requirements of Rule P-21, Basic Manual of Rules, Rates and Forms for the writing of Title Insurance in the State of Texas, the following disclosures are made:

1. The following individuals are directors and/or officers, as indicated, of the Title Insurance Company issuing this Commitment

The issuing Title Insurance Company, Commonwealth Land Title Insurance Company, is a corporation whose shareholders owning or controlling, directly or indirectly, 10% of said corporation, directors and officers are listed below:

Shareholders: Chicago Title Insurance Company, which is owned 100% by Fidelity National Title Group, Inc. which is owned 100% by FNTG Holdings, LLC which is owned 100% by Fidelity National Financial, Inc.

Directors: Raymond Randall Quirk, Anthony John Park, Roger S. Jewkes, Theodore L. Kessner, Erika Meinhardt.

Officers: President, Randal Raymond Quirk, Executive Vice President, Anthony John Park, Secretary Michael Louis Gravelle, Treasurer, Daniel Kennedy Murphy

2. The following disclosures are made by the Title Insurance Agent issuing this Commitment: **Luna Buyer, LLC dba Aggieland Title Company**
 - (a) A listing of each shareholder, owner, partner, or other person having, owning or controlling one percent (1%) or more of the Title Insurance Agent that will receive a portion of the premium.
Underway One Texas, LLC, Jason Parnell Bienski, Douglas Darwood French, Dennis Herbert Goehring, Lance Greer Luna, Otie Carl Luna, Scott Lloyd Luna, AG Title Company, LLC, Chris William Peterson, Page Dane Thornton.
 - (b) A listing of each shareholder, owner, partner, or other person having, owning or controlling 10 percent (10%) or more of an entity that has, owns or controls one percent (1%) or more of the Title Insurance Agent that will receive a portion of the premium. None
 - (c) If the Agent is a corporation: (i) the name of each director of the Title Insurance Agent, and (ii) the names of the President, the Executive or Senior Vice-President, the Secretary and the Treasurer of the Title Insurance Agent.
Officers/Directors: CEO, Scott Lloyd Luna; President, Page Dane Thornton; Secretary, Dennis Herbert Goehring; Treasurer, Otie Carl Luna.
 - (d) The name of any person who is not a full-time employee of the Title Insurance Agent and who receives any portion of the title insurance premium for services performed on behalf of the Title Insurance Agent in connection with the issuance of a title insurance form; and, the amount of premium that any such person shall receive. None.
 - (e) For purposes of this paragraph 2, "having, owning or controlling" includes the right to receipt of a percentage of net income, gross income, or cash flow of the Agent or entity in the percentage stated in subparagraphs (a) or (b).

3. You are entitled to receive advance disclosure of settlement charges in connection with the proposed transaction to which this commitment relates. Upon your request, such disclosure will be made to you. Additionally, the name of any person, firm or corporation receiving a portion of the premium from the settlement of this transaction will be disclosed on the closing or settlement statement.

Continuation of Schedule D

You are further advised that the estimated title premium* is:

	<u>\$5,861.00</u>
Owner's Policy	<u>\$0.00</u>
Loan Policy	<u>\$0.00</u>
Endorsement Charges	<u>\$0.00</u>
Other	<u>\$5,861.00</u>
Total	

Of this total amount: 15% will be paid to the policy issuing Title Insurance Company; 60% will be retained by the issuing Title Insurance Agent; and the remainder of the estimated premium will be paid to other parties as follows:

<u>Amount</u>	<u>To Whom</u>	<u>For Services</u>
25.00%	J. Fred Bayliss	Closing Fee Attorney

" *The estimated premium is based upon information furnished to us as of the date of this Commitment for Title Insurance. Final determination of the amount of the premium will be made at closing in accordance with the Rules and Regulations adopted by the Commissioner of Insurance."

DELETION OF ARBITRATION PROVISION
(Not applicable to the Texas Residential Owner's Policy)

ARBITRATION is a common form of alternative dispute resolution. It can be a quicker and cheaper means to settle a dispute with your Title Insurance Company. However, if you agree to arbitrate, you give up your right to take the Title Insurance Company to court and your rights to discovery of evidence may be limited in the arbitration process. In addition, you cannot usually appeal an arbitrator's award.

Your policy contains an arbitration provision (shown below). It allows you or the Company to require arbitration if the amount of insurance is \$2,000,000 or less. If you want to retain your right to sue the Company in case of a dispute over a claim, you must request deletion of the arbitration provision before the policy is issued. You can do this by signing this form and returning it to the Company at or before the closing of your real estate transaction or by writing to the Company.

The arbitration provision in the Policy is as follows:

"Either the Company or the Insured may demand that the claim or controversy shall be submitted to arbitration pursuant to the Title Insurance Arbitration Rules of the American Land Title Association ("Rules"). Except as provided in the Rules, there shall be no joinder or consolidation with claims or controversies of other persons. Arbitrable matters may include, but are not limited to, any controversy or claim between the Company and the Insured arising out of or relating to this policy, any service in connection with its issuance or the breach of a policy provision, or to any other controversy or claim arising out of the transaction giving rise to this policy. All arbitrable matters when the Amount of Insurance is \$2,000,000 or less shall be arbitrated at the option of either the Company or the Insured, unless the Insured is an individual person (as distinguished from an Entity). All arbitrable matters when the Amount of Insurance is in excess of \$2,000,000 shall be arbitrated only when agreed to by both the Company and the Insured. Arbitration pursuant to this policy and under the Rules shall be binding upon the parties. Judgment upon the award rendered by the Arbitrator(s) may be entered in any court of competent jurisdiction."

SIGNATURE

DATE

THE FOLLOWING COMMITMENT FOR TITLE INSURANCE IS NOT VALID UNLESS YOUR NAME AND THE POLICY AMOUNT ARE SHOWN IN SCHEDULE A, AND OUR AUTHORIZED REPRESENTATIVE HAS COUNTERSIGNED BELOW.

COMMITMENT FOR TITLE INSURANCE T-7
ISSUED BY

COMMONWEALTH LAND TITLE INSURANCE COMPANY

We (COMMONWEALTH LAND TITLE INSURANCE COMPANY) will issue our title insurance policy or policies (the Policy) to You (the proposed insured) upon payment of the premium and other charges due, and compliance with the requirements in Schedule C. Our Policy will be in the form approved by the Texas Department of Insurance at the date of issuance, and will insure your interest in the land described in Schedule A. The estimated premium for our Policy and applicable endorsements is shown on Schedule D. There may be additional charges such as recording fees, and expedited delivery expenses.

This Commitment ends ninety (90) days from the effective date, unless the Policy is issued sooner, or failure to issue the Policy is our fault. Our liability and obligations to you are under the express terms of this Commitment and end when this Commitment expires.

COMMONWEALTH LAND TITLE INSURANCE COMPANY

AGGIELAND TITLE COMPANY
3740 Copperfield Dr., Suite 101
Bryan, TX 77802
979 / 731-8400

Agent

[Handwritten Signature]
Authorized Countersignature



By: *[Handwritten Signature]*
Attest: *[Handwritten Signature]*

President
Secretary

CONDITIONS AND STIPULATIONS

1. If you have actual knowledge of any matter which may affect the title or mortgage covered by this Commitment, that is not shown in Schedule B, you must notify us in writing. If you do not notify us in writing, our liability to you is ended or reduced to the extent that your failure to notify us affects our liability. If you do notify us, or we learn of such matter, we may amend Schedule B, but we will not be relieved of liability already incurred.
2. Our liability is only to you, and others who are included in the definition of Insured in the Policy to be issued. Our liability is only for actual loss incurred in your reliance on this Commitment to comply with its requirements, or to acquire the interest in the land. Our liability is limited to the amount shown in Schedule A of this Commitment and will be subject to the following terms of the Policy: Insuring Provisions, Conditions and Stipulations, and Exclusions.

**COMMITMENT FOR TITLE INSURANCE
(Form T-7) TEXAS TITLE INSURANCE
INFORMATION**

Title insurance insures you against loss resulting from certain risks to your title.

The commitment for Title Insurance is the title insurance company's promise to issue the title insurance policy. The commitment is a legal document. You should review it carefully to completely understand it before your closing date.

El seguro de título le asegura en relación a pérdidas resultantes de ciertos riesgos que pueden afectar el título de su propiedad.

El Compromiso para Seguro de Título es la promesa de la compañía aseguradora de títulos de emitir la póliza de seguro de título. El Compromiso es un documento legal. Usted debe leerlo cuidadosamente y entenderlo completamente antes de la fecha para finalizar su transacción.

Your Commitment for Title Insurance is a legal contract between you and us. The Commitment is not an opinion or report of your title. It is a contract to issue you a policy subject to the Commitment's terms and requirements.

Before issuing a Commitment for Title Insurance (the Commitment) or a Title Insurance Policy (the Policy), the Title Insurance Company (the Company) determines whether the title is insurable. This determination has already been made. Part of that determination involves the Company's decision to insure the title except for certain risks that will not be covered by the Policy. Some of these risks are listed in Schedule B of the attached Commitment as Exceptions. Other risks are stated in the Policy as Exclusions. These risks will not be covered by the Policy. The Policy is not an abstract of title nor does a Company have an obligation to determine the ownership of any mineral interest.

- **MINERALS AND MINERAL RIGHTS** may not be covered by the Policy. The Company may be unwilling to insure title unless there is an exclusion or an exception as to Minerals and Mineral Rights in the Policy. Optional endorsements insuring certain risks involving minerals, and the use of improvements (excluding lawns, shrubbery and trees) and permanent buildings may be available for purchase. If the title insurer issues the title policy with an exclusion or exception to the minerals and mineral rights, neither this Policy, nor the optional endorsements, ensure that the purchaser has title to the mineral rights related to the surface estate.

Another part of the determination involves whether the promise to insure is conditioned upon certain requirements being met. Schedule C of the Commitment lists these requirements that must be satisfied or the Company will refuse to cover them. You may want to discuss any matters shown in Schedules B and C of the Commitment with an attorney. These matters will affect your title and your use of the land.

When your Policy is issued, the coverage will be limited by the Policy's Exceptions, Exclusions and Conditions, defined below.

- **EXCEPTIONS** are title risks that a Policy generally covers but does not cover in a particular instance. Exceptions are shown on Schedule B or discussed in Schedule C of the Commitment. They can also be added if you do not comply with the Conditions section of the Commitment. When the Policy is issued, all Exceptions will be on

Schedule B of the Policy.

EXCLUSIONS are title risks that a Policy generally does not cover. Exclusions are contained in the Policy but not shown or discussed in the Commitment.

CONDITIONS are additional provisions that qualify or limit your coverage. Conditions include your responsibilities and those of the Company. They are contained in the Policy but not shown or discussed in the Commitment. The Policy Conditions are not the same as the Commitment Conditions.

You can get a copy of the policy form approved by the Texas Department of Insurance by calling the Title Insurance Company at 1-(800) 442-7067 or by calling the title insurance agent that issued the Commitment. The Texas Department of Insurance may revise the policy form from time to time.

You can also get a brochure that explains the policy from the Texas Department of Insurance by calling 1-800-252-3439.

Before the Policy is issued, you may request changes in the policy. Some of the changes to consider are:

- Request amendment of the "area and boundary" exception (Schedule B, paragraph 2). To get this amendment, you must furnish a survey and comply with other requirements of the Company. On the Owner's Policy, you must pay an additional premium for the amendment. If the survey is acceptable to the Company and if the Company's other requirements are met, your Policy will insure you against loss because of discrepancies or conflicts in boundary lines, encroachments or protrusions, or overlapping of improvements. The Company may then decide not to insure against specific boundary or survey problems by making special exceptions in the Policy. Whether or not you request amendment of the "area and boundary" exception, you should determine whether you want to purchase and review a survey if a survey is not being provided to you.

- Allow the Company to add an exception to "rights of parties in possession." If you refuse this exception, the Company or the title insurance agent may inspect the property. The Company may except to and not insure you against the rights of specific persons, such as renters, adverse owners or easement holders who occupy the land. The Company may charge you for the inspection. If you want to make your own inspection, you must sign a Waiver of Inspection form and allow the Company to add this exception to your Policy.

The entire premium for a Policy must be paid when the Policy is issued. You will not owe any additional premiums unless you want to increase your coverage at a later date and the Company agrees to add an Increased Value Endorsement.

DELETION OF ARBITRATION PROVISION

(Not applicable to the Texas Residential Owner's Policy)

ARBITRATION is a common form of alternative dispute resolution. It can be a quicker and cheaper means to settle a dispute with your Title Insurance Company. However, if you agree to arbitrate, you give up your right to take the Title Insurance Company to court and your rights to discovery of evidence may be limited in the arbitration process. In addition, you cannot usually appeal an arbitrator's award.

Your policy contains an arbitration provision (shown below). It allows you or the Company to require arbitration if the amount of insurance is \$2,000,000 or less. If you want to retain your right to sue the Company in case of a dispute over a claim, you must request deletion of the arbitration provision before the policy is issued. You can do this by signing this form and returning it to the Company at or before the closing of your real estate transaction or by writing to the Company.

The arbitration provision in the Policy is as follows:

"Either the Company or the Insured may demand that the claim or controversy shall be submitted to arbitration pursuant to the Title Insurance Arbitration Rules of the American Land Title Association ("Rules"). Except as provided in the Rules, there shall be no joinder or consolidation with claims or controversies of other persons. Arbitrable matters may include, but are not limited to, any controversy or claim between the Company and the Insured arising out of or relating to this policy, any service in connection with its issuance or the breach of a policy provision, or to any other controversy or claim arising out of the transaction giving rise to this policy. All arbitrable matters when the Amount of Insurance is \$2,000,000 or less shall be arbitrated at the option of either the Company or the Insured, unless the Insured is an individual person (as distinguished from an Entity). All arbitrable matters when the Amount of Insurance is in excess of \$2,000,000 shall be arbitrated only when agreed to by both the Company and the Insured. Arbitration pursuant to this policy and under the Rules shall be binding upon parties. Judgment upon the award rendered by the Arbitrator(s) may be entered in any court of competent jurisdiction."

SIGNATURE

DATE

AGGIELAND TITLE COMPANY
Privacy Policy Notice

PURPOSE OF THIS NOTICE

Title V of the Gramm-Leach-Bliley Act (GLBA) generally prohibits any financial institution, directly or through its affiliates, from sharing nonpublic personal information about you with a nonaffiliated third party unless the institution provides you with a notice of its privacy policies and practices, such as the type of information that it collects about you and the categories of persons or entities to whom it may be disclosed. In compliance with the GLBA, we are providing you with this document, which notifies you of the privacy policies and practices of **COMMONWEALTH LAND TITLE INSURANCE COMPANY AND AGGIELAND TITLE COMPANY.**

We may collect nonpublic personal information about you from the following sources:

- Information we receive from you such as on applications or other forms.
- Information about your transactions we secure from our files or from our affiliates or others.
- Information we receive from a consumer reporting agency.
- Information that we receive from others involved in your transaction, such as the Real Estate Agent or Lender.

Unless it is specifically stated otherwise in an amended Privacy Policy Notice, no additional nonpublic personal information will be collected about you.

We may disclose any of the above information that we collect about our customers or former customers to our affiliates or to nonaffiliated third parties as permitted by law.

We also may disclose this information about our customers or former customers to the following types of nonaffiliated companies that perform services on our behalf or with whom we have joint marketing agreements:

- Financial service providers such as companies engaged in banking, consumer finance, securities and insurance.
- Non-financial companies such as envelope stuffers and other fulfillment service providers.

WE DO NOT DISCLOSE ANY NONPUBLIC PERSONAL INFORMATION ABOUT YOU WITH ANYONE FOR ANY PURPOSE THAT IS NOT SPECIFICALLY PERMITTED BY LAW.

We restrict access to nonpublic personal information about you to those employees who need to know that information in order to provide products or services to you. We maintain physical, electronic and procedural safeguards that comply with federal regulations to guard your personal information.

AGGIELAND
& TITLE COMPANY
Where Experience and Relationships are Key!

NORMAL CURATIVE MATTERS

 First American Title	Commitment for Title Insurance (T-7)
	ISSUED BY First American Title Insurance Company
Commitment	

THE FOLLOWING COMMITMENT FOR TITLE INSURANCE IS NOT VALID UNLESS YOUR NAME AND THE POLICY AMOUNT ARE SHOWN IN **SCHEDULE A** AND OUR AUTHORIZED REPRESENTATIVE HAS COUNTERSIGNED BELOW.

We FIRST AMERICAN TITLE INSURANCE COMPANY will issue our title insurance policy or policies (the Policy) to You (the proposed insured) upon payment of the premium and other charges due, and compliance with the requirements in Schedule B and Schedule C. Our Policy will be in the form approved by the Texas Department of Insurance at the date of issuance, and will insure your interest in the land described in Schedule A. The estimated premium for our Policy and applicable endorsements is shown on Schedule D. There may be additional charges such as recording fees, and expedited delivery expenses.

This Commitment ends ninety (90) days from the effective date, unless the Policy is issued sooner, or failure to issue the Policy is our fault. Our liability and obligations to you are under the express terms of this Commitment and end when this Commitment expires.

First American Title Insurance Company



Dennis J. Gilmore

Dennis J. Gilmore
President

Timothy Kemp

Timothy Kemp
Secretary

TEXAS TITLE INSURANCE INFORMATION

<p>Title insurance insures you against loss resulting from certain risks to your title.</p> <p>The commitment for Title Insurance is the title insurance company's promise to issue the title insurance policy. The commitment is a legal document. You should review it carefully to completely understand it before your closing date.</p>	<p>El seguro de título le asegura en relación a pérdidas resultantes de ciertos riesgos que pueden afectar el título de su propiedad.</p> <p>El Compromiso para Seguro de Título es la promesa de la compañía aseguradora de títulos de emitir la póliza de seguro de título. El Compromiso es un documento legal. Usted debe leerlo cuidadosamente y enterderlo completamente antes de la fecha para finalizar su transacción.</p>
--	---

Your Commitment for Title Insurance is a legal contract between you and us. The Commitment is not an opinion or report of your title. It is a contract to issue you a policy subject to the Commitment's terms and requirements.

Before issuing a Commitment for Title Insurance (the Commitment) or a Title Insurance Policy (the Policy), the Title Insurance Company (the Company) determines whether the title is insurable. This determination has already been made. Part of that determination involves the Company's decision to insure the title except for certain risks that will not be covered by the Policy. Some of these risks are listed in Schedule B of the attached Commitment as Exceptions. Other risks are stated in the Policy as Exclusions. These risks will not be covered by the Policy. The Policy is not an abstract of title nor does a Company have an obligation to determine the ownership of any mineral interest.

- **MINERALS AND MINERAL RIGHTS** may not be covered by the Policy. The Company may be unwilling to insure title unless there is an exclusion or an exception as to Minerals and Mineral Rights in the Policy. Optional endorsements insuring certain risks involving minerals, and the use of improvements (excluding lawns, shrubbery and trees) and permanent buildings may be available for purchase. If the title insurer issues the title policy with an exclusion or exception to the minerals and mineral rights, neither this Policy, nor the optional endorsements, ensure that the purchaser has title to the mineral rights related to the surface estate.

Another part of the determination involves whether the promise to insure is conditioned upon certain requirements being met. Schedule C of the Commitment lists these requirements that must be satisfied or the Company will refuse to cover them. You may want to discuss any matters shown in Schedules B and C of the Commitment with an attorney. These matters will affect your title and your use of the land.

When your Policy is issued, the coverage will be limited by the Policy's Exceptions, Exclusions and Conditions, defined below.

- **EXCEPTIONS** are title risks that a Policy generally covers but does not cover in a particular instance. Exceptions are shown on Schedule B or discussed in Schedule C of the Commitment. They can also be added if you do not comply with the Conditions section of the Commitment. When the Policy is issued, all Exceptions will be on Schedule B of the Policy.

- **EXCLUSIONS** are title risks that a Policy generally does not cover. Exclusions are contained in the Policy but not shown or discussed in the Commitment.

- **CONDITIONS** are additional provisions that qualify or limit your coverage. Conditions include your responsibilities and those of the Company. They are contained in the Policy but not shown or discussed in the Commitment. The Policy Conditions are not the same as the Commitment Conditions.

You can get a copy of the policy form approved by the Texas Department of Insurance by calling the Title Insurance Company at 1-888-632-1642 or by calling the title insurance agent that issued the Commitment. Texas Department of Insurance may revise the policy form from time to time.

You can also get a brochure that explains the policy from the Texas Department of Insurance by calling 1-800-252-3439.

Before the Policy is issued, you may request changes in the policy. Some of the changes to consider are:

- Request amendment of the "area and boundary" exception (Schedule B, paragraph 2). To get this amendment, you must furnish a survey and comply with other requirements of the Company. On the Owner's Policy, you must pay an additional premium for the amendment. If the survey is acceptable to the Company and if the Company's other requirements are met, your Policy will insure you against loss because of discrepancies or conflicts in

boundary lines, encroachments or protrusions, or overlapping of improvements. The Company may then decide not to insure against specific boundary or survey problems by making special exceptions in the Policy. Whether or not you request amendment of the "area and boundary" exception, you should determine whether you want to purchase and review a survey if a survey is not being provided to you.

- Allow the Company to add an exception to "rights of parties in possession." If you refuse this exception, the Company or the title insurance agent may inspect the property. The Company may except to and not insure you against the rights of specific persons, such as renters, adverse owners or easement holders who occupy the land. The Company may charge you for the inspection. If you want to make your own inspection, you must sign a Waiver of Inspection form and allow the Company to add this exception to your Policy.

The entire premium for a Policy must be paid when the Policy is issued. You will not owe any additional premiums unless you want to increase your coverage at a later date and the Company agrees to add an Increased Value Endorsement.

CONDITIONS AND STIPULATIONS

1. If you have actual knowledge of any matter which may affect the title or mortgage covered by this Commitment, that is not shown in Schedule B, you must notify us in writing. If you do not notify us in writing, our liability to you is ended or reduced to the extent that your failure to notify us affects our liability. If you do notify us, or we learn of such matter, we may amend Schedule B, but we will not be relieved of liability already incurred.
2. Our liability is only to you, and others who are included in the definition of Insured in the Policy to be issued. Our liability is only for actual loss incurred in your reliance on this Commitment to comply with its requirements or to acquire the interest in the land. Our liability is limited to the amount shown in Schedule A of this Commitment and will be subject to the following terms of the Policy: Insuring Provisions, Conditions and Stipulations, and Exclusions.





First American Title

Important Notice

ISSUED BY:

First American Title Insurance Company

IMPORTANT NOTICE

To obtain information or make a complaint:

You may call First American Title Insurance Company's toll-free telephone number for information or to make a complaint at:

1-888-632-1642

You may also write to First American Title Insurance Company at:

**1 First American Way
Santa Ana, California 92707**

You may contact the Texas Department of Insurance to obtain information on companies, coverages, rights or complaints at:

1-800-252-3439

You may write the Texas Department of Insurance:

P.O. Box 149104
Austin, TX 78714-9104
Fax: (512) 475-1771
Web: <http://www.tdi.state.tx.us>
E-mail: ConsumerProtection@tdi.state.tx.us

PREMIUM OR CLAIM DISPUTES:

Should you have a dispute concerning your premium or about a claim you should contact First American Title Insurance Company first. If the dispute is not resolved, you may contact the Texas Department of Insurance.

ATTACH THIS NOTICE TO YOUR POLICY:

This notice is for information only and does not become a part or condition of the attached document.

AVISO IMPORTANTE

Para obtener informacion o para someter una queja:

Usted puede llamar al numero de telefono gratis de First American Title Insurance Company's para informacion o para someter una queja al:

1-888-632-1642

Usted tambien puede escribir a First American Title Insurance Company:

**1 First American Way
Santa Ana, California 92707**

Puede comunicarse con el Departamento de Seguros de Texas para obtener informacion acerca de companias, coberturas, derechos o quejas al:

1-800-252-3439

Puede escribir al Departamento de Seguros de Texas:

P.O. Box 149104
Austin, TX 78714-9104
Fax: (512) 475-1771
Web: <http://www.tdi.state.tx.us>
E-mail: ConsumerProtection@tdi.state.tx.us

DISPUTAS SOBRE PRIMAS O RECLAMOS:

Si tiene una disputa concerniente a su prima o a un reclamo, debe comunicarse con el First American Title Insurance Company primero. Si no se resuelve la disputa, puede entonces comunicarse con el departamento (TDI).

UNA ESTE AVISO A SU POLIZA:

Este aviso es solo para proposito de informacion y no se convierte en parte o condicion del documento adjunto.

COMMITMENT FOR TITLE INSURANCE T-7
ISSUED BY

FIRST AMERICAN TITLE INSURANCE COMPANY

SCHEDULE A

Effective Date: **April 30, 2018, 8:00 am**

GF No. **BC1807150**

Commitment No. issued **May 10, 2018, 8:00 am**

1. The policy or policies to be issued are:

- a. OWNER'S POLICY OF TITLE INSURANCE (Form T-1)
(Not applicable for improved one-to-four family residential real estate)
Policy Amount: **\$0.00**
PROPOSED INSURED: **No Limits International Development Corporation**
- b. TEXAS RESIDENTIAL OWNER'S POLICY OF TITLE INSURANCE
ONE-TO-FOUR FAMILY RESIDENCES (Form T-1R)
Policy Amount:
PROPOSED INSURED:
- c. LOAN POLICY OF TITLE INSURANCE (Form T-2)
Policy Amount: **\$0.00**
PROPOSED INSURED:
Proposed Borrower: **No Limits International Development Corporation**
- d. TEXAS SHORT FORM RESIDENTIAL LOAN POLICY OF TITLE INSURANCE (Form T-2R)
Policy Amount:
PROPOSED INSURED:
Proposed Borrower:
- e. LOAN TITLE POLICY BINDER ON INTERIM CONSTRUCTION LOAN (Form T-13)
Binder Amount:
PROPOSED INSURED:
Proposed Borrower:
- f. OTHER
Policy Amount:
PROPOSED INSURED:

2. The interest in the land covered by this Commitment is: **Leasehold Estate**

3. Record title to the land on the Effective Date appears to be vested in:

Brazos Valley Community Church of God, Inc.

4. Legal description of land:

Being a remainder portion of all that certain 6.186 acre tract or parcel of land, more or less, lying and being situated in the S. F. Austin League, No. 10, Abstract No. 63, Bryan, Brazos County, Texas, and being out of and a part of that called 6.16 acre tract conveyed from Somerville Church of God, Inc. to Bryan Church of God, Inc., as described by Deed recorded in Volume 587, page 389, Deed Records of Brazos County, Texas, said remainder tract being more particularly described by metes and bounds to be provided. (see Schedule C requirements)

NOTE: The Company is prohibited from insuring the area or quantity of the land described herein. Any statement in the above legal description of the area or quantity of land is not a representation that such area or quantity is correct, but is made only for informational and/or identification purposes and does not override item 2 of Schedule B hereof.

**COMMITMENT FOR TITLE INSURANCE T-7
ISSUED BY**

GF No. **BC1807150**

FIRST AMERICAN TITLE INSURANCE COMPANY

SCHEDULE B

EXCEPTIONS FROM COVERAGE

In addition to the Exclusions and Conditions and Stipulations, your Policy will not cover loss, costs, attorney's fees, and expenses resulting from:

1. The following restrictive covenants of record itemized below (We must either insert specific recording data or delete this exception):

ITEM 1 OF SCHEDULE "B" IS HEREBY DELETED IN ITS ENTIRETY.

2. Any discrepancies, conflicts, or shortages in area or boundary lines, or any encroachments or protrusions, or any overlapping of improvements.
3. Homestead or community property or survivorship rights, if any of any spouse of any insured. (Applies to the Owner's Policy only.)
4. Any titles or rights asserted by anyone, including, but not limited to, persons, the public, corporations, governments or other entities,
 - a. to tidelands, or lands comprising the shores or beds of navigable or perennial rivers and streams, lakes, bays, gulfs or oceans, or
 - b. to lands beyond the line of the harbor or bulkhead lines as established or changed by any government, or
 - c. to filled-in lands, or artificial islands, or
 - d. to statutory water rights, including riparian rights, or
 - e. to the area extending from the line of mean low tide to the line of vegetation, or the rights of access to that area or easement along and across that area.(Applies to the Owner's Policy only.)
5. Standby fees, taxes and assessments by any taxing authority for the year **2018**, and subsequent years; and subsequent taxes and assessments by any taxing authority for prior years due to change in land usage or ownership, but not those taxes or assessments for prior years because of an exemption granted to a previous owner of the property under Section 11.13, Texas Tax Code, or because of improvements not assessed for a previous tax year. (If Texas Short Form Residential Loan Policy of Title Insurance (T-2R) is issued, that policy will substitute "which become due and payable subsequent to Date of Policy" in lieu of "for the year **2018** and subsequent years.")
6. The terms and conditions of the documents creating your interest in the land.
7. Materials furnished or labor performed in connection with planned construction before signing and delivering the lien document described in Schedule A, if the land is part of the homestead of the owner. (Applies to the Loan Title Policy Binder on Interim Construction Loan only, and may be deleted if satisfactory evidence is furnished to us before a binder is issued.)
8. Liens and leases that affect the title to the land, but that are subordinate to the lien of the insured mortgage. (Applies to Loan Policy (T-2) only.)
9. The Exceptions from Coverage and Express Insurance in Schedule B of the Texas Short Form Residential Loan Policy of Title Insurance (T-2R). (Applies to Texas Short Form Residential Loan Policy of Title Insurance (T-2R) only.) Separate exceptions 1 through 8 of this Schedule B do not apply to the Texas Short Form Residential Loan Policy of Title

Continuation of Schedule B

GF No. **BC1807150**

Insurance (T-2R).

10. The following matters and all terms of the documents creating or offering evidence of the matters (We must insert matters or delete this exception.):

- a. **Rights of Parties in possession. (Owner's Policy Only)**
- b. **Easements, or claims of easements, which are not recorded in the public records. (Owner's Policy Only)**
- c. **Subject to any and all visible and or apparent easements over, under or across subject property, which a survey or physical inspection may disclose.**
- d. **Any encroachment, encumbrance violation, variation or adverse circumstance affecting the title that would be disclosed by an accurate and complete land survey of the land.**
- e. **Any portion of the subject property lying within the boundaries of a public or private roadway, whether dedicated or not.**
- f. **Roadway easement as reserved in Deed executed to E.A. Gerke, recorded in Volume 126, Page 408, Deed Records of Brazos County, Texas.**
- g. **Easement granted to General Telephone Company of the Southwest, as set out and described in instrument recorded in Volume 863, Page 455 of the Official Records of Brazos, County, Texas.**
- h. **Easement granted to City of Bryan as set out and described in instrument recorded in Volume 1485, Page 313 of the Official Records of Brazos, County, Texas.**
- i. **Easement granted to City of Bryan as set out and described in instrument recorded in Volume 4506, Page 226 of the Official Records of Brazos, County, Texas.**
- j. **Easement granted to City of Bryan as set out and described in instrument recorded in Volume 4506, Page 231 of the Official Records of Brazos, County, Texas.**
- k. **Mineral interest in and to all coal, lignite, oil, gas and other minerals, and all rights incident thereto, contained in Deed from E.A. Gerke, a/k/a Manuel Gerke, and wife, Mattie Pearl Gerke to Somerville Church of God, Inc. dated July 20, 1978, recorded in Volume 404, page 650, Deed Records of Brazos County, Texas. Reference to which instrument is here made for particulars. No further search of title has been made as to the interest(s) evidenced by this instrument and the Company makes no representation as to the ownership or holder of such interest(s).**
- l. **Estate created by Oil and Gas Lease from E.A. Gerke and wife, Mattie Pearl Gerke to MCZ, Inc., dated April 21, 1981, recorded in Volume 38, page 455, Oil, Gas and Mineral Lease Records of Brazos County, Texas. Title to said lease has not been traced subsequent to the date of the above-cited instrument.**
- m. **Estate created by Oil and Gas Lease from Somerville Church of God, Inc. to MCZ, Inc., dated January 27, 1982, recorded in Volume 52, page 68, Oil, Gas and Mineral Lease Records of Brazos County, Texas. Title to said lease has not been traced subsequent to the date of the above-cited instrument.**
- n. **Estate created by Oil and Gas Lease from Nancy Ann Krolczyk to Halcon Energy Properties, Inc., dated September 18, 2013, as disclosed in Memorandum of Oil and Gas Lease recorded in Volume 11621, page 240, Official Records of Brazos County, Texas. Title to said lease has not been traced subsequent to the date of the above-cited instrument.**
- o. **Estate created by Oil and Gas Lease from Charles G. Gerke to Halcon Energy Properties, Inc., dated**

Continuation of Schedule B

GF No. **BC1807150**

- September 18, 2013, as disclosed in Memorandum of Oil and Gas Lease recorded in Volume 11621, page 241, Official Records of Brazos County, Texas. Title to said lease has not been traced subsequent to the date of the above-cited instrument.
- p. Estate created by Oil and Gas Lease from Mattie Pearl Gerke to Halcon Energy Properties, Inc., dated September 18, 2013, as disclosed in Memorandum of Oil and Gas Lease recorded in Volume 11621, page 272, Official Records of Brazos County, Texas. Title to said lease has not been traced subsequent to the date of the above-cited instrument.
- q. Estate created by Oil and Gas Lease from Brazos Valley Community Church of God, Inc. to Halcon Energy Properties, Inc., dated September 18, 2013, as disclosed in Memorandum of Oil and Gas Lease recorded in Volume 11650, page 57, Official Records of Brazos County, Texas. Title to said lease has not been traced subsequent to the date of the above-cited instrument.
- r. All leases, grants, exceptions or reservations of coal, lignite, oil, gas and other minerals, together with all rights, privileges and immunities relating thereto, appearing in the Public Records whether listed in Schedule B or not. There may be leases, grants, exceptions or reservations of mineral interests that are not listed.
- s. Terms and conditions contained in Boundary Line Agreement by and between E.A. Gerke and Mattie P. Gerke, and Robert C. Stallworth and Dorothy D. Stallworth, in instrument dated May 8, 1980, recorded in Volume 451, page 167, Deed Records of Brazos County, Texas.
- t. Terms, conditions and stipulations contained in that certain Conditional General Warranty Deed, as set out in instrument dated February 1, 2007, recorded in Volume 8490, Page 229 of the Official Records of Brazos County, Texas.
- u. Terms, conditions and stipulations contained in that certain Ground Lease, as set out in instrument dated _____, 2018, to be recorded in Volume _____, Page ____ of the Official Records of Brazos County, Texas.
- v. Deed of Trust dated November 17, 2003, recorded on November 18, 2003 in Volume 5730, page 12, Official Records of Brazos County, Texas, executed by Brazos Valley Community Church of God to Robert K. Nordhaus, securing the payment of one note dated November 17, 2003 in the sum of \$251,595.18, payable to First American Bank, SSB; said note and lien having been assigned to First State Bank, a Nebraska corporation by instrument dated June 20, 2014 and recorded in Volume 12208, page 70, Official Records of Brazos County, Texas.
- w. Deed of trust dated February 1, 2007, recorded in Volume 8490, page 221, Official Records of Brazos County, Texas, executed by Sheldon T. Smith and Cynthia Roberts, acting as President and Secretary, respectively, of the Brazos Valley Community Church of God, Inc. to Richard A. Shuman, Trustee, securing the payment of one note dated February 1, 2007 in the sum of \$63,240.00, payable to Texas Revolving Loan Fund of the Church of God, a Texas non-profit corporation.
- x. Any and all liens arising by reason of unpaid bills or claims for work performed or materials furnished in connection with improvements placed, or to be placed, upon the subject land. However, the Company does insure the Insured against loss, if any, sustained by the Insured under this Policy if such liens have been filed with the County Clerk of Brazos County, Texas.
- y. Pending disbursement of the full proceeds of the loan secured by the lien instrument set forth under Schedule A hereof, this policy insures only to the extent of the amount actually disbursed, but increases as each disbursement is made in good faith and without knowledge of any defects in, or objections to, the title up to the face amount of the policy. Nothing contained in this paragraph shall be construed as limiting any exception under Schedule B, or any printed provisions of this policy. (Loan Title Policy Only)

Continuation of Schedule B

GF No. **BC1807150**

- z. The tax certificate furnished by the taxing authorities is issued on real estate only. It does not include minerals and/or personal property, therefore, no liability is assumed herein for the payment of said mineral and/or personal property tax.**

**COMMITMENT FOR TITLE INSURANCE T-7
ISSUED BY**

GF No. **BC1807150**

**FIRST AMERICAN TITLE INSURANCE COMPANY
SCHEDULE C**

Your Policy will not cover loss, costs, attorneys' fees, and expenses resulting from the following requirements that will appear as Exceptions in Schedule B of the Policy, unless you dispose of these matters to our satisfaction, before the date the Policy is issued:

1. Documents creating your title or interest must be approved by us and must be signed, notarized and filed for record.
2. Satisfactory evidence must be provided that:
 - a. no person occupying the land claims any interest in that land against the persons named in paragraph 3 of Schedule A,
 - b. all standby fees, taxes, assessments and charges against the property have been paid,
 - c. all improvements or repairs to the property are completed and accepted by the owner, and that all contractors, sub-contractors, laborers and suppliers have been fully paid, and that no mechanic's, laborer's or materialmen's liens have attached to the property,
 - d. there is legal right of access to and from the land,
 - e. (on a Loan Policy only) restrictions have not been and will not be violated that affect the validity and priority of the insured mortgage.
3. You must pay the seller or borrower the agreed amount for your property or interest.
4. Any defect, lien or other matter that may affect title to the land or interest insured, that arises or is filed after the effective date of this Commitment.
5. NOTE: Procedural Rule P-27 as provided for in Article 9.39A of the Texas Insurance Code requires that "Good Funds" be received and deposited before a Title Agent may disburse from its Trust Fund Account..
6. **NOTE: We find no outstanding voluntary liens of record affecting the subject (Leasehold) property. Inquiry should be made concerning the existence of any unrecorded lien or other indebtedness which could give rise to any security interest claim in the subject property.**
7. **Company must be furnished a properly executed corporate resolution in recordable form of the Board of Directors of Brazos Valley Community Church of God, Inc. authorizing the proposed transaction and establishing authority of the officers to act on behalf of the corporation. Evidence must be furnished establishing the current corporate standing of said Company.**
8. **Company must be furnished with evidence documenting the type and registration of the business entity known as No Limits International Development Corp. Upon receipt and review of said entity documentation, further requirements may be made.**
9. **Provide to Company a new survey and metes and bounds Legal Description of the proposed subject Leasehold tract, for its review and for possible further requirements.**
10. **Provide to Company a Lease Agreement in original, recordable form, evidencing pertinent terms and conditions of said Lease, and including a Legal Description emulating that which must be approved by the Company, said Agreement being executed by Brazos Valley Community Church of God, Inc., as Landlord, and No Limits International Development Corp., as Tenant, subject to Company review and approval. Said instrument to be recorded in the Official Records of Brazos County, Texas, prior to closing the instant**

Continuation of Schedule C

GF No. **BC1807150**

transaction.

NOTE: Said fee owner, as of the date hereof, is Brazos Valley Community Church of God, Inc., as evidenced in Warranty Deed recorded in Volume 587, Page 388, Deed Records; and as evidenced in instrument recorded in Volume 5730, Page 24, Official Records, both of Brazos County, Texas.

11. **Company requires a Non-Disturbance and Attornment Agreement, executed by and between No Limits International Development Corp. as Leasehold Estate holder, and First State Bank, as holder of Beneficial Interest in Deed of Trust recorded in Volume 5730, Page 12, and as assigned by instrument recorded in Volume 12208, Page 70, of the Official Records, Brazos County, Texas. Said Agreement instrument to be recorded in the Official Public Records of Brazos County, Texas, prior to, or at closing of the instant transaction. Additional Requirements may be made.**
12. **Company requires a Non-Disturbance and Attornment Agreement, executed by and between No Limits International Development Corp. as Leasehold Estate holder, and Texas Revolving Loan Fund of the Church of God, a Texas non-profit corporation, as holder of Beneficial Interest in Deed of Trust recorded in Volume 8490, Page 221, of the Official Records, Brazos County, Texas. Said Agreement instrument to be recorded in the Official Public Records of Brazos County, Texas, prior to, or at closing of the instant transaction. Additional Requirements may be made.**
13. **Company requires proof that the subject property qualified for each ad valorem tax exemption that was granted to it for the last five tax years.**
14. **No work is to be performed or materials delivered to the site prior to the recording of the construction mortgage.**
15. **If any party to the transaction will execute documents based on a Statutory Durable Power of Attorney, Company requires the agent presenting such power of attorney to provide the Company with a Certification of Durable Power of Attorney by Agent, pursuant to Sec. 751.203 of the Texas Estates Code, before the date of closing.**
16. **Company will require tax certificates on the subject property showing all taxes paid up to and including the year 2018.**
17. **Company will require a properly executed Waiver of Inspection.**
18. **Company requires an Affidavit as to Debts and Liens to be executed at closing.**
19. **"The title insurance policy being issued to you contains an Arbitration Provision. It allows you or the Company to require arbitration if the amount of Insurance is \$2,000,000 or less. If you want to retain your right to sue the Company in case of a dispute over a claim, you must request deletion of the Arbitration Provision before the policy is issued. If you are the purchaser in the transaction and elect deletion of the Arbitration Provision, a form will be presented to you at closing for execution. If you are the lender in the transaction and desire deletion of the Arbitration Provision, please inform us through your Closing Instructions."**

INFORMATIONAL NOTE:

1. When an Owner Policy of Title Insurance (Form T-1) is to be issued on a leasehold estate in the land, the Company shall attach to the said Owner Policy (Form T-1) the Leasehold Owner Policy Endorsement. When a Residential Owner Policy of Title Insurance -- One-To-Four Family Residences (Form T-1R) is to be issued on a leasehold estate in the land, the Company shall attach the Residential Leasehold Endorsement form to the Residential Owner Policy -- One-To-Four Family Residences (Form T-1R). The Owner Policy shall show that the estate being insured is a leasehold and exceptions shall be shown under Schedule B to all of the terms,

provisions, and conditions of said lease creating such leasehold estate.

2. When an insured under an Owner Policy shall have satisfied the Company as to the current value of the estate or interest insured by such Owner Policy, and shall have paid the premium provided for in Rule R-3.c., the Company shall attach to the said Owner Policy endorsement form T-34.

3. When an Owner Policy is issued in the manner provided in Rule P-8.a., and the coverage thereunder increases as provided in Rule R-2, Rule P-8 or otherwise as provided in these Rules, upon request and compliance with Rule R-15, the title insurance company which issued the Owner Policy may extend the effective date of the said Owner Policy and state the amount then existing under such Policy by issuing the endorsement provided for in Form T-3, Instruction VIII, Items (a) 1, 2 and 3 of the endorsement may not be deleted.

Countersigned
South Land Title, LLC

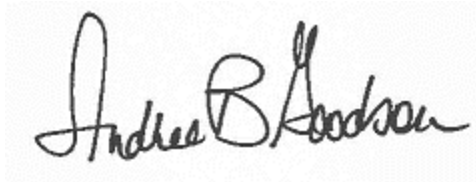
A handwritten signature in black ink that reads "Andree B. Anderson". The signature is written in a cursive style with a large initial 'A'.

By
Authorized Countersignature

COMMITMENT FOR TITLE INSURANCE

SCHEDULE D

GF No. **BC1807150**

Effective Date: **April 30, 2018, 8:00 am**

Pursuant to the requirements of Rule P-21, Basic Manual of Rules, Rates and Forms for the writing of Title Insurance in the State of Texas, the following disclosures are made:

1. The following individuals are directors and/or officers, as indicated, of the Title Insurance Company issuing this Commitment **UNDERWRITER: First American Title Insurance Company, a Nebraska Corporation.**

Shareholder owning or controlling, directly or indirectly, ten percent or more of the share of the Underwriter: First American Title Insurance Company is a wholly owned subsidiary of First American Financial Corporation, a public Company formed in Delaware.

Directors: Dennis J. Gilmore, Christopher M. Leavell, Jeffrey S. Robinson, Mark E. Seaton, Ellen C. Albrecht

Officers: President, Chief Executive Officer: Dennis J. Gilmore; Senior Vice President, Secretary: Jeffrey S. Robinson; and Chief Financial Officer: Mark E. Seaton

2. The issuing Title Insurance Agent, **South Land Title, LLC** a Texas Limited Liability Company, whose members owning or controlling, directly or indirectly, 1% or more of said company (or owning or controlling 10% or more of an entity that owns 1% or more of the Agent), and managers are listed below:

Patrick F. Doyle, President

South Land Title, LLC is owned 100% by Texan Title Holdings, LLC which is owned 100% by Patrick F. Doyle.

3. You are entitled to receive advance disclosure of settlement charges in connection with the proposed transaction to which this commitment relates. Upon your request, such disclosure will be made to you. Additionally, the name of any person, firm or corporation receiving a portion of the premium from the settlement of this transaction will be disclosed on the closing or settlement statement.

You are further advised that the estimated title premium* is:

Owner's Policy	<u>\$0.00</u>
Loan Policy	<u>\$238.00</u>
Endorsement Charges	<u>\$0.00</u>
Other	<u>\$0.00</u>
Total	<u>\$238.00</u>

Of this total amount: 15% will be paid to the policy issuing Title Insurance Company, 85 % will be retained by the issuing Title Insurance Agent; and the remainder of the estimated premium will be paid to other parties as follows:

<u>Amount</u>	<u>To Whom</u>	<u>For Services</u>
---------------	----------------	---------------------

" *The estimated premium is based upon information furnished to us as of the date of this Commitment for Title Insurance. Final determination of the amount of the premium will be made at closing in accordance with the Rules and Regulations adopted by the Commissioner of Insurance."

COMMITMENT FOR TITLE INSURANCE (Form T-7)

TEXAS TITLE INSURANCE INFORMATION

Title insurance insures you against loss resulting from certain risks to your title.

The commitment for Title Insurance is the title insurance company's promise to issue the title insurance policy. The commitment is a legal document. You should review it carefully to completely understand it before your closing date.

El seguro de título le asegura en relación a pérdidas resultantes de ciertos riesgos que pueden afectar el título de su propiedad.

El Compromiso para Seguro de Título es la promesa de la compañía aseguradora de títulos de emitir la póliza de seguro de título. El Compromiso es un documento legal. Usted debe leerlo cuidadosamente y entenderlo completamente antes de la fecha para finalizar su transacción.

Your Commitment of Title insurance is a legal contract between you and us. The Commitment is not an opinion or report of your title. It is a contract to issue you a policy subject to the Commitment's terms and requirements.

Before issuing a Commitment for Title Insurance (the Commitment) or a Title Insurance Policy (the Policy), the Title Insurance Company (the Company) determines whether the title is insurable. This determination has already been made. Part of that determination involves the Company's decision to insure the title except for certain risks that will not be covered by the Policy. Some of these risks are listed in Schedule B of the attached Commitment as Exceptions. Other risks are stated in the Policy as Exclusions. These risks will not be covered by the Policy. The Policy is not an abstract of title nor does a Company have an obligation to determine the ownership of any mineral interest.

- **MINERALS AND MINERAL RIGHTS** may not be covered by the Policy. The Company may be unwilling to insure title unless there is an exclusion or an exception as to Minerals and Mineral Rights in the Policy. Optional endorsements insuring certain risks involving minerals, and the use of improvements (excluding lawns, shrubbery and trees) and permanent buildings may be available for purchase. If the title insurer issues the title policy with an exclusion or exception to the minerals and mineral rights, neither this Policy, nor the optional endorsements, ensure that the purchaser has title to the mineral rights related to the surface estate.

Another part of the determination involves whether the promise to insure is conditioned upon certain requirements being met. Schedule C of the Commitment lists these requirements that must be satisfied or the Company will refuse to cover them. You may want to discuss any matters shown in Schedules B and C of the Commitment with an attorney. These matters will affect your title and your use of the land.

When your policy is issued, the coverage will be limited by the Policy's Exceptions, Exclusions and Conditions, defined below.

- **EXCEPTIONS** are title risks that a Policy generally covers but does not cover in a particular instance. Exceptions are shown on Schedule B or discussed in Schedule C of the Commitment. They can also be added if you do not comply with the Conditions section of the Commitment. When the Policy is issued, all Exceptions will be on Schedule B of the Policy.

- **EXCLUSIONS** are title risks that a Policy generally does not cover. Exclusions are contained in the Policy but not shown or discussed in the Commitment.

- **CONDITIONS** are additional provisions that qualify or limit your coverage. Conditions include your responsibilities and those of the Company. They are contained in the Policy but not shown or discussed in the Commitment. The Policy Conditions are not the same as the Commitment Conditions.

Continuation of Texas Title Insurance Information

GF No. **BC1807150**

You can get a copy of the policy form approved by the Texas Department of Insurance by calling the Title Insurance Company at (800) 347-7826 or by calling the title insurance agent that issued the Commitment. The Texas Department of Insurance may revise the policy form from time to time.

You can also get a brochure that explains the policy from the Texas Department of Insurance by calling 1-800-252-3439.

Before the Policy is issued, you may request changes in the policy. Some of the changes to consider are:

- Request amendment of the "area and boundary" exception (Schedule B, paragraph 2). To get this amendment, you must furnish a survey and comply with other requirements of the Company. On the Owner's Policy, you must pay an additional premium for the amendment. If the survey is acceptable to the Company and if the Company's other requirements are met, your Policy will insure you against loss because of discrepancies or conflicts in boundary lines, encroachments or protrusions, or overlapping of improvements. The Company may then decide not to insure against specific boundary or survey problems by making special exceptions in the Policy. Whether or not you request amendment of the "area and boundary" exception, you should determine whether you want to purchase and review a survey if a survey is not being provided to you.
- Allow the Company to add an exception to "rights of parties in possession." If you refuse this exception, the Company or the title insurance agent may inspect the property. The Company may except to and not insure you against the rights of specific persons, such as renters, adverse owners or easement holders who occupy the land. The Company may charge you for the inspection. If you want to make your own inspection, you must sign a Waiver of Inspection form and allow the Company to add this exception to your Policy.

The entire premium for a Policy must be paid when the Policy is issued. You will not owe any additional premiums unless you want to increase your coverage at a later date and the Company agrees to add an Increased Value Endorsement.

DELETION OF ARBITRATION PROVISION
(Not applicable to the Texas Residential Owner's Policy)

ARBITRATION is a common form of alternative dispute resolution. It can be a quicker and cheaper means to settle a dispute with your Title Insurance Company. However, if you agree to arbitrate, you give up your right to take the Title Insurance Company to court and your rights to discovery of evidence may be limited in the arbitration process. In addition, you cannot usually appeal an arbitrator's award.

Your policy contains an arbitration provision (shown below). It allows you or the Company to require arbitration if the amount of insurance is \$2,000,000 or less. If you want to retain your right to sue the Company in case of a dispute over a claim, you must request deletion of the arbitration provision before the policy is issued. You can do this by signing this form and returning it to the Company at or before the closing of your real estate transaction or by writing to the Company.

The arbitration provision in the Policy is as follows:

"Either the Company or the Insured may demand that the claim or controversy shall be submitted to arbitration pursuant to the Title Insurance Arbitration Rules of the American Land Title Association ("Rules"). Except as provided in the Rules, there shall be no joinder or consolidation with claims or controversies of other persons. Arbitrable matters may include, but are not limited to, any controversy or claim between the Company and the Insured arising out of or relating to this policy, any service in connection with its issuance or the breach of a policy provision, or to any other controversy or claim arising out of the transaction giving rise to this policy. All arbitrable matters when the Amount of Insurance is \$2,000,000 or less shall be arbitrated at the option of either the Company or the Insured, unless the Insured is an individual person (as distinguished from an Entity). All arbitrable matters when the Amount of Insurance is in excess of \$2,000,000 shall be arbitrated only when agreed to by both the Company and the Insured. Arbitration pursuant to this policy and under the Rules shall be binding upon the parties. Judgment upon the award rendered by the Arbitrator(s) may be entered in any court of competent jurisdiction."

SIGNATURE

DATE

(Not applicable to the Texas Residential Owner's Policy)

First American Title Insurance Company

Premium Amount	Rate Rules	Property Type	County Code	Liability at Reissue Rate	6	7	8
1 \$238.00	2 3000	3 3	4 41	5	6	7	8

**DISCLOSURE TO SELLER, BUYER/BORROWER ABOUT
PATRICK F. DOYLE AND DOYLE LAW FIRM, PLLC**

I. REPRESENTATION OF INTERESTS

In connection with the transaction you are closing today, a document of conveyance and/or curative documents have been prepared on behalf of Seller and Buyer/Borrower, and/or a loan has been obtained from a lending institution (or individual owner under an owner-finance) to finance all or part of the purchase price of Borrower's property, or to refinance an earlier loan made to Borrower, or which Borrower assumed, that is secured on the subject property. Seller, Buyer/Borrower or and/or lender is using the services of the law firm of **DOYLE LAW FIRM, PLLC** in the preparation of various legal instruments and loan documents in connection with this transaction, and you must pay for such services. By signing below, Borrower is acknowledging that **DOYLE LAW FIRM, PLLC** has not represented Borrower's interests or given Borrower any legal advice concerning the contract to sell and purchase the property, if applicable, or otherwise related to the property or to the legal instruments and loan documents executed in connection with the home loan transaction or the closing of the transaction itself.

II. RELATIONSHIP OF PATRICK F. DOYLE AND DOYLE LAW FIRM, PLLC

PATRICK F. DOYLE is the sole owner of the law firm of **DOYLE LAW FIRM, PLLC**.

III. RELATIONSHIP OF TITLE COMPANY AND PATRICK F. DOYLE

PATRICK F. DOYLE is the sole owner of **Texan Title Holdings, LLC**, which is the parent company of **SOUTH LAND TITLE, LLC**, located in **Bryan, Texas**

IV. RELATIONSHIP OF TAX SERVICE PROVIDER AND PATRICK F. DOYLE

PATRICK F. DOYLE is the sole owner of **Realty Tax Search, Inc.**, which provides ad valorem tax searches and collects, stores and disseminates real estate information regarding your transaction and a standard fee for services related thereto.

VI. FREEDOM TO HIRE A LAWYER

By signing below, each party hereto acknowledges that they have had the opportunity to consult independent counsel or hire an attorney to represent them regarding this transaction and its consequences.

VII. OBLIGATION TO PAY LEGAL FEES

By signing below, each party acknowledges that they must pay at the time of closing, or on demand, the legal fees of **DOYLE LAW FIRM, PLLC** as each party may have agreed to pay in the contract of sale and purchase or in the loan application or any other document they may have signed. The charges for the services of **DOYLE LAW FIRM, PLLC** are set forth on the closing statement or settlement statement furnished by the closing agent. You have not been charged any fee for preparation of any Truth-in-Lending Statement or RESPA Good Faith Estimate of closing costs. Attached hereto as **Exhibit "A"** and incorporated herein is **PATRICK F. DOYLE**'s Affiliated Business Arrangement Disclosure Statement, which sets forth **DOYLE LAW FIRM, PLLC**'s relationship to **PATRICK F. DOYLE** and Settlement Service Charge or range of charges.

VIII. DESCRIPTION OF LEGAL SERVICES

In representing the lender's interest in this loan transaction, **DOYLE LAW FIRM, PLLC** provided a variety of services of a legal nature. **DOYLE LAW FIRM, PLLC** reviews as necessary the sales contract, survey, title report or commitment of title insurance, various documents of record such as restrictions and easements, and typically prepares such instruments as the Note, Deed of Trust, Affidavits and various miscellaneous documents required by the lender.

Furthermore, each party hereto acknowledges that **DOYLE LAW FIRM, PLLC** may have prepared certain documents upon the request of **South Land Title, LLC**, and has not in any manner, undertaken to assist or render legal advice to the undersigned, with respect to this transaction. The attorney preparing the documents represents **South Land Title, LLC**.

Each party hereto has been provided with an opportunity to examine the title commitment issued by the title company in this transaction, and are satisfied with the contents of such commitment. Further, each party hereto agrees and understands that this transaction is not "closed" until all disbursements are made on behalf of all parties. In the event there are any additional charges for anyone furnishing services, requiring payoff, or by any taxing authority, each party hereto will pay such charges upon written request.

The undersigned understand and agree that the parties may allocate payment of legal fees between themselves as they may agree.

IX. ACKNOWLEDGEMENT/WHAT SIGNING THIS MEANS

By signing below, you acknowledge to the lender, **DOYLE LAW FIRM, PLLC** and **PATRICK F. DOYLE** that you have received a copy of this disclosure, that you have read all of the above statements, that you understand them, and that what has been stated in this disclosure is accurate and truthful. Furthermore, you acknowledge that you have read this disclosure form and understand that **PATRICK F. DOYLE** is referring you to purchase the settlement services as described herein on **Exhibit "A"** and may receive a financial or other benefit as the result of this referral.

EXHIBIT "A"

**AFFILIATED BUSINESS ARRANGEMENT DISCLOSURE STATEMENT
NOTICE**

FROM: PATRICK F. DOYLE

GF#: BC1807150

This is to give you notice that **PATRICK F. DOYLE** has a business relationship with and ownership interest in **REALTY TAX SEARCH, INC.** and **TEXAN TITLE HOLDINGS, LLC**, which is the parent company of **SOUTH LAND TITLE, LLC**. **PATRICK F. DOYLE**, sole owner of the law firm of **DOYLE LAW FIRM, PLLC**, is also the sole owner of **TEXAN TITLE HOLDINGS, LLC**, which is the parent company of **SOUTH LAND TITLE, LLC** (real estate closing services) .

Set forth below is the estimated charge or range of charges of the settlement services listed. You are **NOT** required to use the listed providers as a condition for closing your transaction of the subject property. **THERE ARE OTHER SETTLEMENT SERVICE PROVIDERS AVAILABLE WITH SIMILAR SERVICES. YOU ARE FREE TO SHOP AROUND TO DETERMINE THAT YOU ARE RECEIVING THE BEST SERVICES AND THE BEST RATE FOR THESE SERVICES.**

Provider and Settlement Services Charge or Range of Charges:

SOUTH LAND TITLE, LLC (premium fees as set by
State Board of Insurance
and vary depending on
value of transaction and
credits available to
consumer)

Realty Tax Search **\$81.19**

ACKNOWLEDGEMENT

I/we have read this disclosure form, and understand that Patrick F. Doyle is referring me/us to purchase the above-described settlement services and may receive a financial or other benefit as the result of this referral.

**SOUTH LAND TITLE, LLC
PRIVACY POLICY**

PURPOSE OF THIS NOTICE

Title V of the Gramm-Leach-Bliley Act (GLBA) generally prohibits any financial institution, directly or through its affiliates, from sharing nonpublic personal information about you with a non-affiliated third party unless the institution provides you with a notice of its privacy policies and practices, such as the type of information that it collects about you and the categories of persons or entities to whom it may be disclosed. In compliance with the GLBA, we are providing you with this document, which notifies you of the privacy policies and practices of **SOUTH LAND TITLE, LLC**.

We may collect nonpublic personal information about you from the following sources:

- Information we receive from you, such as on applications or other forms
- Information about your transactions we secure from our files, or from our affiliates or others
- Information we receive from a consumer reporting agency
- Information that we receive from others involved in your transaction, such as the real estate agent or lender

Unless it is specifically stated otherwise in an amended Privacy Policy Notice, no additional nonpublic personal information will be collected about you.

WE DO NOT DISCLOSE ANY NONPUBLIC PERSONAL INFORMATION ABOUT OUR CUSTOMERS OR FORMER CUSTOMERS TO ANYONE, EXCEPT AS PERMITTED BY LAW.

WE RESTRICT ACCESS TO NONPUBLIC PERSONAL INFORMATION ABOUT YOU TO THOSE EMPLOYEES WHO NEED TO KNOW THAT INFORMATION TO PROVIDE THE PRODUCTS OR SERVICES REQUESTED BY YOU OR YOUR LENDER.

WE MAINTAIN PHYSICAL, ELECTRONIC, AND PROCEDURAL SAFEGUARDS THAT COMPLY WITH APPROPRIATE FEDERAL AND STATE REGULATIONS.

NO PERSON, ENTITY OR FIRM WHO IS NOT A PARTY TO YOUR CONTRACT IS PERMITTED TO RECEIVE ANY INFORMATION FROM THIS COMPANY ON ANY MATTER RELATED TO YOUR CONTRACT.

**DOYLE LAW FIRM, PLLC
PRIVACY POLICY NOTICE**

PURPOSE OF THIS NOTICE

Title V of the Gramm-Leach-Bliley Act (GLBA) generally prohibits any financial institution, directly or through its affiliates, from sharing nonpublic personal information about you with a nonaffiliated third party unless the institution provides you with a notice of its privacy policies and practices, such as the type of information that it collects about you and the categories of persons or entities to whom it may be disclosed. In compliance with the GLBA, we are providing you with this document, which notifies you of the privacy policies and practices of **DOYLE LAW FIRM, PLLC**

We may collect nonpublic personal information about you from the following sources:

- Information we receive from you, such as on applications or other forms
- Information about your transactions we secure from our files, or from our affiliates or others
- Information we receive from a consumer reporting agency
- Information that we receive from others involved in your transaction, such as the real estate agent or lender

Unless it is specifically stated otherwise in an amended Privacy Policy Notice, no additional nonpublic personal information will be collected about you.

WE DO NOT DISCLOSE ANY NONPUBLIC PERSONAL INFORMATION ABOUT YOU WITH ANYONE FOR ANY PURPOSE THAT IS NOT SPECIFICALLY PERMITTED BY LAW.

We restrict access to nonpublic personal information about you to those employees who need to know that information in order to provide products or services to you. We maintain physical, electronic and procedural safeguards that comply with federal regulations to guard your nonpublic personal information.

Brazos Valley Community Church of God, Inc.
6.19 Acres
S. F. Austin Survey, A-63
Bryan, Brazos County, Texas

Field notes of a 6.19 acre tract or parcel of land, lying and being situated in the S. F. Austin Survey, Abstract No. 63, Bryan, Brazos County, Texas, and being all of the 6.186 acre tract described in the deed from Sheldon T. Smith and Cynthia Roberts, acting as President and Secretary respectively of the Brazos Valley Community Church of God, Inc., for and in behalf of the Brazos Valley Community Church of God, Inc., to The Texas Revolving Loan Fund of the Church of God, recorded in Volume 8490, Page 229, of the Official Records of Brazos County, Texas, and said 6.19 acre tract being more particularly described as follows:

BEGINNING at a 1/2" iron rod and cap set in the northwest right-of-way line of State Highway No. 21 - 100' wide right-of-way, at the common corner between the beforementioned 6.186 acre tract and Lot 1R, Block 1, Old Hearne Road Subdivision - 14.747 acres, according to the plat recorded in Volume 10073, Page 226, of the Official Records of Brazos County, Texas;

THENCE along the common line between the beforementioned 6.816 acre tract, and the beforementioned Lot 1R, Block 1, as follows:

N 50° 23' 44" W for a distance of 382.19 feet to a 1/2" iron rod and cap set,
N 50° 29' 45" W for a distance of 569.81 feet to a 1/2" iron rod and cap set,
N 57° 07' 22" W at a distance of 351.35 feet, pass the north corner of Lot 1R, Block 1, continue on, for a total distance of 368.47 feet, to a 1/2" iron rod found bent, in the east right-of-way line of Old Hearne Road, and at the west corner of the said 6.186 acre tract;

THENCE N 03° 59' 13" E along the common line between the beforementioned 6.186 acre tract and Old Hearne Road, for a distance of 119.23 feet to a 1/2" iron rod found marking the common corner between the said 6.186 acre tract and a 1.07 acre tract described in the deed to Freddie D. Moody, recorded in Volume 8817, Page 38, of the Official Records of Brazos County, Texas;

THENCE along the common line between the beforementioned 6.186 acre tract and the beforementioned 1.07 acre tract, as follows:

S 58° 52' 18" E at a distance of 14.53 feet, pass a 5/8" iron rod and cap found, continue on, for a total distance of 211.46 feet to a 1/2" iron rod found bent,
N 29° 02' 03" E at a distance of 149.65 feet, pass a 1/2" iron rod found, continue on, for a total distance of 152.81 feet and corner in the southwest line of Lot Y-1, Block 14, Chatham-Northview, according to the plat recorded in Volume 144, Page 613, of the Deed Records of Brazos County, Texas, said lot described in the deed Kent Louis Lyons, recorded in Volume 9005, Page 257, of the Official Records of Brazos County, Texas, from which a 3/8" iron rod found bears N 41° 35' E - 0.5 feet;

THENCE S 47° 40' 03" E along the common line between the beforementioned 6.186 acre tract, lying to the southwest, and the following three tracts, lying to the northeast: the beforementioned Lot Y-1, Block 14, a 1.194 acre tract, described in the deed to Angelica Campos, recorded in Volume 14006, Page 218, of the Official Records of Brazos County, Texas, and a 4.99 acre tract described in the deed to John W. Hale, recorded in Volume 1299, Page 128, of the Official Records of Brazos County, Texas, adjacent to a fence, for a distance of 1248.50 feet to a 1/2" iron rod and cap found in the northwest right-of-way line of the beforementioned State Highway No. 21, at the common corner between the said 6.186 acre tract and the 4.99 acre tract;

THENCE S 52° 45' 23" W along the common line between the beforementioned 6.181 acre tract and State Highway No. 21, for a distance of 179.44 feet to the **PLACE OF BEGINNING**, containing 6.19 acres of land, more or less.

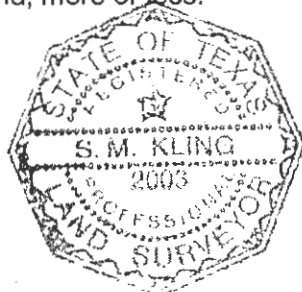

Surveyed: January, 2018
By: *S.M.Kling*
S. M. Kling
R.P.L.S. No. 2003

Prepared 01/31/18
Brazos Valley Church of God - 6.19ac - 601200
BCS Proj_2018-E0601200 - field notes file



Oncor Electric Delivery Company LLC
a Delaware limited liability company

December 8, 2017

Donna McGinnis
Oncor Electric Delivery
308 S. 7th Street
Temple, Texas 76504

Arlinda Gardens Supportive Housing,
Bryan, Texas
Attn: Rick Sims

Re: 2002 Hwy 21 East, Bryan, Texas

Please be advised that Oncor Electric Delivery Company LLC, a Delaware limited liability company, can provide electric service to the above referenced site. Service will be provided upon request in accordance with our tariffs and service regulations on file with the Public Utility Commission of Texas.

If you have questions or need additional information, please feel free to contact me.

Sincerely,

A handwritten signature in black ink that reads "Donna McGinnis". The signature is written in a cursive, flowing style.

Donna McGinnis
New Construction Manager

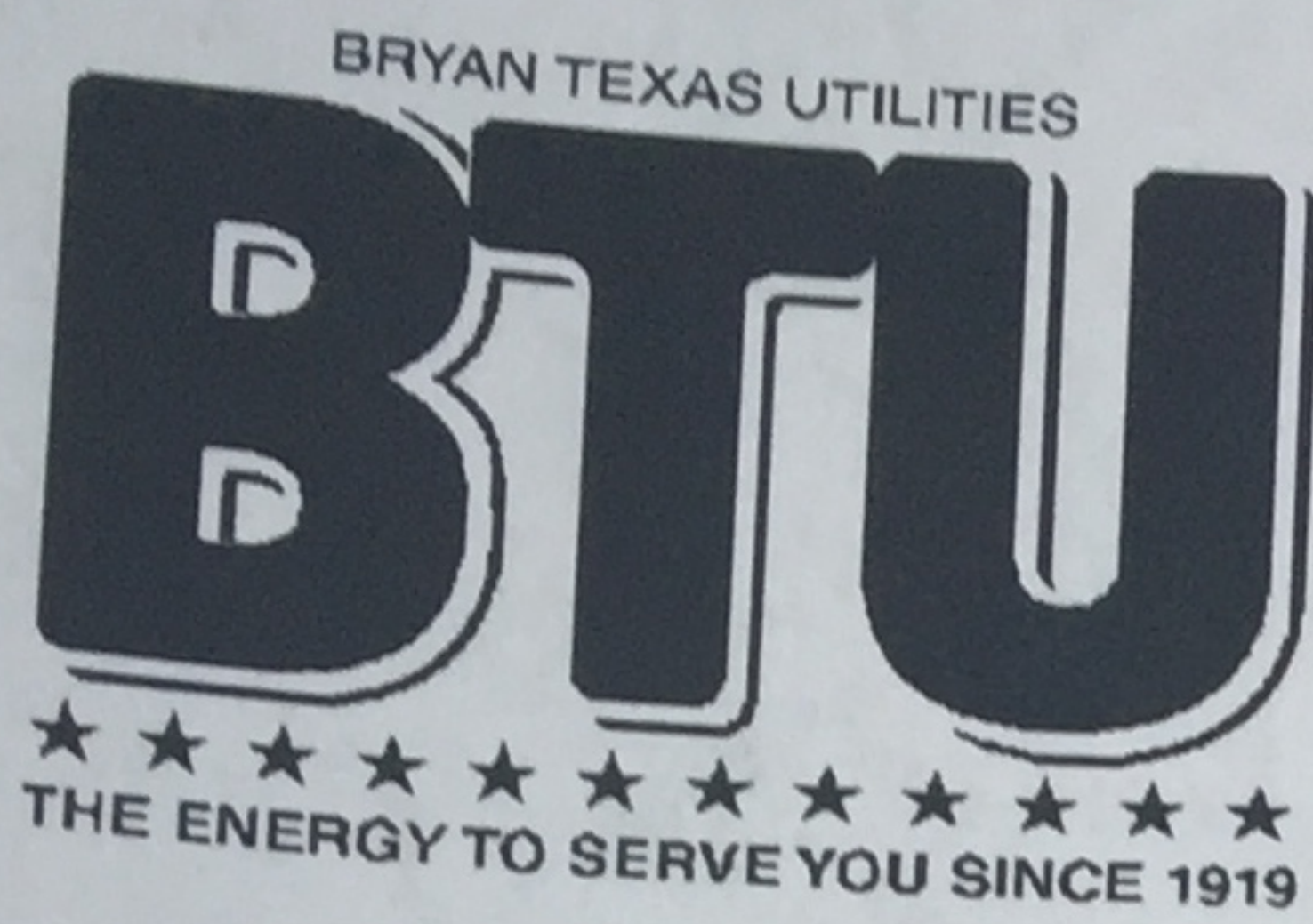

February 28, 2018

Brazos Valley Community Church of God
2002 E State Highway 21
Bryan, TX 77803

Re: Utility Account

To Whom It May Concern:

This letter is to verify that the City of Bryan provides the following services to the above stated location (Electric, Water, Waste Water, Solid Waste and Drainage & Transportation). If you have any questions, please contact our office at 979-821-5700

Sincerely,

April Bonifazi
Bryan Texas Utilities
Customer Service
979-821-5700

SERVICE CONTRACT

The applicant whose name appears on the front side of this form applies for and agrees to pay for available utility service furnished by Bryan Texas Utilities at the requested location at the rate established by the City of Bryan as now existing or as may be enacted by City Ordinance. This agreement is binding until applicant gives proper notice to discontinue service.

The applicant also agrees that if at any time there is failure to pay when due, any charge for service or repairs, BTU may discontinue service to any or all meters in the name of the applicant until arrears are paid, plus an additional service charge for turning all utilities back on. I agree that BTU may hold me responsible for the past unpaid utility bills of any additional locations or buildings that had utility services in my name. I authorize BTU to transfer the balances of such unpaid utility bills to my active account and to disconnect my utilities if those balances are not paid in full. The City of Bryan is not responsible for loss resulting from interrupted service. The applicant also acknowledges that meters are the property of BTU, and that they may be turned on and off only by authorized City Employees. Any unauthorized connection of a meter is illegal and will result in immediate termination of service. I, the undersigned applicant, hereby grant to the City of Bryan the right of access to its meters whenever necessary.

The applicant also agrees to abide by and consider as part of this contract any ordinance, rules, and regulations the City adopts concerning BTU – Municipal and Rural.

I hereby apply for service in accordance with the terms of this Service Contract, and affirm that the information that I have provided on this form is, to my knowledge, true and correct. I understand that BTU is relying on this information to furnish me utility service and that if any of this information is determined to be false or incorrect for the purpose of misleading or defrauding BTU, my utility service may be terminated immediately without any further notice to me.

Signature of Authorized Person

Title

Date

Confidentiality

The Texas Utilities Code, Chapter 182, provides that a customer may request that personal information and any information relating to the volume or units of utility usage, including amounts billed to or collected from, is kept confidential.* If you wish to request confidentiality of that information, check this box:

*Notwithstanding your request, the information may be released to (1) an official or employee of the state, a political subdivision of the state, or the United States acting in an official capacity; (2) an employee of a utility acting in connection with the employee's duties; (3) a consumer reporting agency; (4) a contractor or subcontractor approved by and providing services to the utility, the state, a political subdivision of the state, or the United States; (5) a person for whom the customer has contractually waived confidentiality for personal information; or (6) another entity that provides water, wastewater, sewer, gas, garbage, electricity, or drainage service for compensation.



DP-1

Profile of General Population and Housing Characteristics: 2010

2010 Demographic Profile Data

NOTE: For more information on confidentiality protection, nonsampling error, and definitions, see <http://www.census.gov/prod/cen2010/doc/dpsf.pdf>.

Geography: Bryan city, Texas

Subject	Number	Percent
SEX AND AGE		
Total population	76,201	100.0
Under 5 years	6,325	8.3
5 to 9 years	5,473	7.2
10 to 14 years	4,798	6.3
15 to 19 years	6,098	8.0
20 to 24 years	10,075	13.2
25 to 29 years	7,455	9.8
30 to 34 years	5,546	7.3
35 to 39 years	4,613	6.1
40 to 44 years	4,265	5.6
45 to 49 years	4,375	5.7
50 to 54 years	4,144	5.4
55 to 59 years	3,346	4.4
60 to 64 years	2,730	3.6
65 to 69 years	1,969	2.6
70 to 74 years	1,546	2.0
75 to 79 years	1,272	1.7
80 to 84 years	1,032	1.4
85 years and over	1,139	1.5
Median age (years)	28.5	(X)
16 years and over	58,648	77.0
18 years and over	56,689	74.4
21 years and over	51,308	67.3
62 years and over	8,563	11.2
65 years and over	6,958	9.1
Male population	38,255	50.2
Under 5 years	3,173	4.2
5 to 9 years	2,772	3.6
10 to 14 years	2,438	3.2
15 to 19 years	3,249	4.3
20 to 24 years	5,525	7.3
25 to 29 years	3,850	5.1
30 to 34 years	2,894	3.8
35 to 39 years	2,302	3.0
40 to 44 years	2,112	2.8
45 to 49 years	2,184	2.9
50 to 54 years	2,031	2.7
55 to 59 years	1,655	2.2
60 to 64 years	1,261	1.7

Subject	Number	Percent
65 to 69 years	868	1.1
70 to 74 years	674	0.9
75 to 79 years	517	0.7
80 to 84 years	393	0.5
85 years and over	357	0.5
Median age (years)	27.4	(X)
16 years and over	29,378	38.6
18 years and over	28,389	37.3
21 years and over	25,428	33.4
62 years and over	3,544	4.7
65 years and over	2,809	3.7
Female population	37,946	49.8
Under 5 years	3,152	4.1
5 to 9 years	2,701	3.5
10 to 14 years	2,360	3.1
15 to 19 years	2,849	3.7
20 to 24 years	4,550	6.0
25 to 29 years	3,605	4.7
30 to 34 years	2,652	3.5
35 to 39 years	2,311	3.0
40 to 44 years	2,153	2.8
45 to 49 years	2,191	2.9
50 to 54 years	2,113	2.8
55 to 59 years	1,691	2.2
60 to 64 years	1,469	1.9
65 to 69 years	1,101	1.4
70 to 74 years	872	1.1
75 to 79 years	755	1.0
80 to 84 years	639	0.8
85 years and over	782	1.0
Median age (years)	29.7	(X)
16 years and over	29,270	38.4
18 years and over	28,300	37.1
21 years and over	25,880	34.0
62 years and over	5,019	6.6
65 years and over	4,149	5.4
RACE		
Total population	76,201	100.0
One Race	74,240	97.4
White	48,939	64.2
Black or African American	13,748	18.0
American Indian and Alaska Native	420	0.6
Asian	1,313	1.7
Asian Indian	549	0.7
Chinese	202	0.3
Filipino	94	0.1
Japanese	37	0.0
Korean	117	0.2
Vietnamese	155	0.2
Other Asian [1]	159	0.2
Native Hawaiian and Other Pacific Islander	52	0.1
Native Hawaiian	11	0.0
Guamanian or Chamorro	22	0.0
Samoan	4	0.0

Subject	Number	Percent
Other Pacific Islander [2]	15	0.0
Some Other Race	9,768	12.8
Two or More Races	1,961	2.6
White; American Indian and Alaska Native [3]	263	0.3
White; Asian [3]	184	0.2
White; Black or African American [3]	399	0.5
White; Some Other Race [3]	725	1.0
Race alone or in combination with one or more other races: [4]		
White	50,613	66.4
Black or African American	14,374	18.9
American Indian and Alaska Native	814	1.1
Asian	1,623	2.1
Native Hawaiian and Other Pacific Islander	101	0.1
Some Other Race	10,733	14.1
HISPANIC OR LATINO		
Total population	76,201	100.0
Hispanic or Latino (of any race)	27,617	36.2
Mexican	24,699	32.4
Puerto Rican	228	0.3
Cuban	99	0.1
Other Hispanic or Latino [5]	2,591	3.4
Not Hispanic or Latino	48,584	63.8
HISPANIC OR LATINO AND RACE		
Total population	76,201	100.0
Hispanic or Latino	27,617	36.2
White alone	16,167	21.2
Black or African American alone	342	0.4
American Indian and Alaska Native alone	245	0.3
Asian alone	35	0.0
Native Hawaiian and Other Pacific Islander alone	12	0.0
Some Other Race alone	9,690	12.7
Two or More Races	1,126	1.5
Not Hispanic or Latino	48,584	63.8
White alone	32,772	43.0
Black or African American alone	13,406	17.6
American Indian and Alaska Native alone	175	0.2
Asian alone	1,278	1.7
Native Hawaiian and Other Pacific Islander alone	40	0.1
Some Other Race alone	78	0.1
Two or More Races	835	1.1
RELATIONSHIP		
Total population	76,201	100.0
In households	73,104	95.9
Householder	27,725	36.4
Spouse [6]	10,920	14.3
Child	21,504	28.2
Own child under 18 years	16,506	21.7
Other relatives	6,118	8.0
Under 18 years	2,628	3.4
65 years and over	455	0.6
Nonrelatives	6,837	9.0
Under 18 years	289	0.4
65 years and over	101	0.1
Unmarried partner	1,835	2.4
In group quarters	3,097	4.1

Subject	Number	Percent
Institutionalized population	2,822	3.7
Male	1,673	2.2
Female	1,149	1.5
Noninstitutionalized population	275	0.4
Male	118	0.2
Female	157	0.2
HOUSEHOLDS BY TYPE		
Total households	27,725	100.0
Family households (families) [7]	16,702	60.2
With own children under 18 years	8,279	29.9
Husband-wife family	10,920	39.4
With own children under 18 years	5,023	18.1
Male householder, no wife present	1,504	5.4
With own children under 18 years	639	2.3
Female householder, no husband present	4,278	15.4
With own children under 18 years	2,617	9.4
Nonfamily households [7]	11,023	39.8
Householder living alone	7,784	28.1
Male	3,529	12.7
65 years and over	528	1.9
Female	4,255	15.3
65 years and over	1,503	5.4
Households with individuals under 18 years	9,448	34.1
Households with individuals 65 years and over	5,041	18.2
Average household size	2.64	(X)
Average family size [7]	3.31	(X)
HOUSING OCCUPANCY		
Total housing units	30,582	100.0
Occupied housing units	27,725	90.7
Vacant housing units	2,857	9.3
For rent	1,597	5.2
Rented, not occupied	123	0.4
For sale only	222	0.7
Sold, not occupied	76	0.2
For seasonal, recreational, or occasional use	188	0.6
All other vacants	651	2.1
Homeowner vacancy rate (percent) [8]	1.6	(X)
Rental vacancy rate (percent) [9]	9.9	(X)
HOUSING TENURE		
Occupied housing units	27,725	100.0
Owner-occupied housing units	13,370	48.2
Population in owner-occupied housing units	37,550	(X)
Average household size of owner-occupied units	2.81	(X)
Renter-occupied housing units	14,355	51.8
Population in renter-occupied housing units	35,554	(X)
Average household size of renter-occupied units	2.48	(X)

X Not applicable.

[1] Other Asian alone, or two or more Asian categories.

[2] Other Pacific Islander alone, or two or more Native Hawaiian and Other Pacific Islander categories.

[3] One of the four most commonly reported multiple-race combinations nationwide in Census 2000.

[4] In combination with one or more of the other races listed. The six numbers may add to more than the total population, and the six

percentages may add to more than 100 percent because individuals may report more than one race.

[5] This category is composed of people whose origins are from the Dominican Republic, Spain, and Spanish-speaking Central or South American countries. It also includes general origin responses such as "Latino" or "Hispanic."

[6] "Spouse" represents spouse of the householder. It does not reflect all spouses in a household. Responses of "same-sex spouse" were edited during processing to "unmarried partner."

[7] "Family households" consist of a householder and one or more other people related to the householder by birth, marriage, or adoption. They do not include same-sex married couples even if the marriage was performed in a state issuing marriage certificates for same-sex couples. Same-sex couple households are included in the family households category if there is at least one additional person related to the householder by birth or adoption. Same-sex couple households with no relatives of the householder present are tabulated in nonfamily households. "Nonfamily households" consist of people living alone and households which do not have any members related to the householder.

[8] The homeowner vacancy rate is the proportion of the homeowner inventory that is vacant "for sale." It is computed by dividing the total number of vacant units "for sale only" by the sum of owner-occupied units, vacant units that are "for sale only," and vacant units that have been sold but not yet occupied; and then multiplying by 100.

[9] The rental vacancy rate is the proportion of the rental inventory that is vacant "for rent." It is computed by dividing the total number of vacant units "for rent" by the sum of the renter-occupied units, vacant units that are "for rent," and vacant units that have been rented but not yet occupied; and then multiplying by 100.

Source: U.S. Census Bureau, 2010 Census.



DP-1

Profile of General Population and Housing Characteristics: 2010

2010 Demographic Profile Data

NOTE: For more information on confidentiality protection, nonsampling error, and definitions, see <http://www.census.gov/prod/cen2010/doc/dpsf.pdf>.

Geography: Census Tract 3, Brazos County, Texas

Subject	Number	Percent
SEX AND AGE		
Total population	7,211	100.0
Under 5 years	690	9.6
5 to 9 years	703	9.7
10 to 14 years	632	8.8
15 to 19 years	621	8.6
20 to 24 years	541	7.5
25 to 29 years	597	8.3
30 to 34 years	546	7.6
35 to 39 years	484	6.7
40 to 44 years	445	6.2
45 to 49 years	411	5.7
50 to 54 years	409	5.7
55 to 59 years	341	4.7
60 to 64 years	280	3.9
65 to 69 years	170	2.4
70 to 74 years	128	1.8
75 to 79 years	96	1.3
80 to 84 years	61	0.8
85 years and over	56	0.8
Median age (years)	28.7	(X)
16 years and over	5,056	70.1
18 years and over	4,797	66.5
21 years and over	4,450	61.7
62 years and over	684	9.5
65 years and over	511	7.1
Male population	3,534	49.0
Under 5 years	331	4.6
5 to 9 years	345	4.8
10 to 14 years	346	4.8
15 to 19 years	311	4.3
20 to 24 years	274	3.8
25 to 29 years	301	4.2
30 to 34 years	276	3.8
35 to 39 years	219	3.0
40 to 44 years	211	2.9
45 to 49 years	207	2.9
50 to 54 years	182	2.5
55 to 59 years	184	2.6
60 to 64 years	121	1.7

Subject	Number	Percent	
65 to 69 years	75	1.0	
70 to 74 years	54	0.7	
75 to 79 years	44	0.6	
80 to 84 years	28	0.4	
85 years and over	25	0.3	
Median age (years)	27.7	(X)	
16 years and over	2,456	34.1	
18 years and over	2,326	32.3	
21 years and over	2,148	29.8	
62 years and over	303	4.2	
65 years and over	226	3.1	
Female population	3,677	51.0	
Under 5 years	359	5.0	
5 to 9 years	358	5.0	
10 to 14 years	286	4.0	
15 to 19 years	286	4.0	
20 to 24 years	310	4.3	
25 to 29 years	267	3.7	
30 to 34 years	296	4.1	
35 to 39 years	270	3.7	
40 to 44 years	265	3.7	
45 to 49 years	234	3.2	
50 to 54 years	40 to 44 years	204	2.8
55 to 59 years	45 to 49 years	227	3.1
60 to 64 years	50 to 54 years	157	2.2
65 to 69 years	55 to 59 years	159	2.2
70 to 74 years	60 to 64 years	95	1.3
75 to 79 years	65 to 69 years	74	1.0
80 to 84 years	70 to 74 years	52	0.7
85 years and over	75 to 79 years	33	0.5
Median age (years)	80 to 84 years	31	0.4
	85 years and over		
	29.5	(X)	
16 years and over	2,600	36.1	
18 years and over	2,471	34.3	
21 years and over	2,302	31.9	
62 years and over	381	5.3	
65 years and over	285	4.0	
RACE			
Total population	7,211	100.0	
One Race	6,996	97.0	
White	4,393	60.9	
Black or African American	1,304	18.1	
American Indian and Alaska Native	35	0.5	
Asian	25	0.3	
Asian Indian	3	0.0	
Chinese	2	0.0	
Filipino	4	0.1	
Japanese	3	0.0	
Korean	1	0.0	
Vietnamese	9	0.1	
Other Asian [1]	3	0.0	
Native Hawaiian and Other Pacific Islander	0	0.0	
Native Hawaiian	0	0.0	
Guamanian or Chamorro	0	0.0	
Samoan	0	0.0	

Subject	Number	Percent
Other Pacific Islander [2]	0	0.0
Some Other Race	1,239	17.2
Two or More Races	215	3.0
White; American Indian and Alaska Native [3]	38	0.5
White; Asian [3]	15	0.2
White; Black or African American [3]	34	0.5
White; Some Other Race [3]	89	1.2
Race alone or in combination with one or more other races: [4]		
White	4,577	63.5
Black or African American	1,355	18.8
American Indian and Alaska Native	87	1.2
Asian	49	0.7
Native Hawaiian and Other Pacific Islander	7	0.1
Some Other Race	1,361	18.9
HISPANIC OR LATINO		
Total population	7,211	100.0
Hispanic or Latino (of any race)	3,550	49.2
Mexican	3,153	43.7
Puerto Rican	30	0.4
Cuban	1	0.0
Other Hispanic or Latino [5]	366	5.1
Not Hispanic or Latino	3,661	50.8
HISPANIC OR LATINO AND RACE		
Total population	7,211	100.0
Hispanic or Latino	3,550	49.2
White alone	2,125	29.5
Black or African American alone	33	0.5
American Indian and Alaska Native alone	23	0.3
Asian alone	3	0.0
Native Hawaiian and Other Pacific Islander alone	0	0.0
Some Other Race alone	1,235	17.1
Two or More Races	131	1.8
Not Hispanic or Latino	3,661	50.8
White alone	2,268	31.5
Black or African American alone	1,271	17.6
American Indian and Alaska Native alone	12	0.2
Asian alone	22	0.3
Native Hawaiian and Other Pacific Islander alone	0	0.0
Some Other Race alone	4	0.1
Two or More Races	84	1.2
RELATIONSHIP		
Total population	7,211	100.0
In households	7,211	100.0
Householder	2,269	31.5
Spouse [6]	1,192	16.5
Child	2,702	37.5
Own child under 18 years	2,037	28.2
Other relatives	705	9.8
Under 18 years	347	4.8
65 years and over	50	0.7
Nonrelatives	343	4.8
Under 18 years	30	0.4
65 years and over	7	0.1
Unmarried partner	170	2.4
In group quarters	0	0.0

Subject	Number	Percent
Institutionalized population	0	0.0
Male	0	0.0
Female	0	0.0
Noninstitutionalized population	0	0.0
Male	0	0.0
Female	0	0.0
HOUSEHOLDS BY TYPE		
Total households	2,269	100.0
Family households (families) [7]	1,784	78.6
With own children under 18 years	990	43.6
Husband-wife family	1,192	52.5
With own children under 18 years	632	27.9
Male householder, no wife present	164	7.2
With own children under 18 years	87	3.8
Female householder, no husband present	428	18.9
With own children under 18 years	271	11.9
Nonfamily households [7]	485	21.4
Householder living alone	378	16.7
Male	174	7.7
65 years and over	36	1.6
Female	204	9.0
65 years and over	84	3.7
Households with individuals under 18 years	1,127	49.7
Households with individuals 65 years and over	391	17.2
Average household size	3.18	(X)
Average family size [7]	3.58	(X)
HOUSING OCCUPANCY		
Total housing units	2,435	100.0
Occupied housing units	2,269	93.2
Vacant housing units	166	6.8
For rent	52	2.1
Rented, not occupied	6	0.2
For sale only	31	1.3
Sold, not occupied	20	0.8
For seasonal, recreational, or occasional use	10	0.4
All other vacants	47	1.9
Homeowner vacancy rate (percent) [8]	1.9	(X)
Rental vacancy rate (percent) [9]	7.1	(X)
HOUSING TENURE		
Occupied housing units	2,269	100.0
Owner-occupied housing units	1,598	70.4
Population in owner-occupied housing units	4,975	(X)
Average household size of owner-occupied units	3.11	(X)
Renter-occupied housing units	671	29.6
Population in renter-occupied housing units	2,236	(X)
Average household size of renter-occupied units	3.33	(X)

X Not applicable.

[1] Other Asian alone, or two or more Asian categories.

[2] Other Pacific Islander alone, or two or more Native Hawaiian and Other Pacific Islander categories.

[3] One of the four most commonly reported multiple-race combinations nationwide in Census 2000.

[4] In combination with one or more of the other races listed. The six numbers may add to more than the total population, and the six

03/01/2017

percentages may add to more than 100 percent because individuals may report more than one race.

[5] This category is composed of people whose origins are from the Dominican Republic, Spain, and Spanish-speaking Central or South American countries. It also includes general origin responses such as "Latino" or "Hispanic."

[6] "Spouse" represents spouse of the householder. It does not reflect all spouses in a household. Responses of "same-sex spouse" were edited during processing to "unmarried partner."

[7] "Family households" consist of a householder and one or more other people related to the householder by birth, marriage, or adoption. They do not include same-sex married couples even if the marriage was performed in a state issuing marriage certificates for same-sex couples. Same-sex couple households are included in the family households category if there is at least one additional person related to the householder by birth or adoption. Same-sex couple households with no relatives of the householder present are tabulated in nonfamily households. "Nonfamily households" consist of people living alone and households which do not have any members related to the householder.

[8] The homeowner vacancy rate is the proportion of the homeowner inventory that is vacant "for sale." It is computed by dividing the total number of vacant units "for sale only" by the sum of owner-occupied units, vacant units that are "for sale only," and vacant units that have been sold but not yet occupied; and then multiplying by 100.

[9] The rental vacancy rate is the proportion of the rental inventory that is vacant "for rent." It is computed by dividing the total number of vacant units "for rent" by the sum of the renter-occupied units, vacant units that are "for rent," and vacant units that have been rented but not yet occupied; and then multiplying by 100.

Source: U.S. Census Bureau, 2010 Census.

Travel time from the site to places of employment is from 2 to 18 minutes by automobile. The cost of travel is determined by the cost of gas and the type of automobile used it would approximately be between \$5.00 to \$10.00. If we calculate gas prices at \$2.00 per gallon and multiply by the maximum 5 miles to employment and assuming 1 mile per gallon

How Development Promotes Greater Choice in Housing

The Noah Arc Community Development Inc is a nonprofit corporation organized in the state of Louisiana and Texas. The Noah Arc Community Development Inc. mission is to provide capacity building to community based organizations in the rural areas of both Louisiana and Texas in the area of affordable housing.

The proposed development is a capacity building project involving two communities based non profits seeking CHDO certification.

The organization meet the qualifications for CHDO's, first they are organized and registered non profits. Each organization has at least one year of community service in their desired geographical areas. Each organization has at least 1/3 of the board of directors composed with low income representation. Each organization during the pre development process conducted meeting for low income input. And finally each organization has contracted Rick Sims as Executive Director for the day to day operation of the CHDO's.

During this pre development stage both non profits with low income input and low income representation selected the site for the proposed development that would provide a greater choice to the residents of Bryan. The proposed development Arlinda Gardens Supportive Housing will be the only rental housing sub- division of this type in the City of Bryan.

The low income residents on the board of directors of both non profits pride themselves on creating this multi family development for the low income residents in the City of Bryan.

The community will consist of 29 detached cottage style homes, meaning each unit will have its own individual lot. This difference allows residents to feel a part of a community while maintaining their individual privacy from their other neighbors.

There are very few options for affordable housing that meets the standard has habitable in Bryan, the low income residents decided that a development with 4 or more units per building carries a negative stigma of being government housing. The low income residents decided this proposed development has a positive image for the individuals and the city. By providing high quality rental detached housing to this rural community gives the residents a greater choice in housing and to residents that will help they and their families, especially disabled residents, are truly given the choice to live in an integrated setting that fits their needs to live safe and healthy lives.

This development will not create an undue concentration as assisted persons in the area due to the fact that there are numerous uninhabitable blighted dilapidated houses and trailer that family

with children resides. The development can only give the current low income residents a much greater choice in the city of Bryan.



TEXAS DEPARTMENT OF
HOUSING & COMMUNITY AFFAIRS
Building Homes. Strengthening Communities.

TAB 13

**Multiple Site
Information Form**

Multiple Site Information Form

This exhibit is required if a development site is assembled by aggregating noncontiguous tracts conveyed by one contract, or tracts conveyed by more than one contract whether contiguous or not. For each contract, list the address, legal description and acreage of each tract. The sum of the acreages must equal or exceed the acreage of the corresponding site plan(s) before dedications and other foreseeable reductions. Provide a reconciliation of any discrepancy (dedications, takings, reserves for other uses, etc.). **Behind this form, provide a plat of the acquisitions that correspond to each distinct development site. The plat should state the dimensions of each tract and identify the address, legal description and acreage. If the development site boundaries do not match the boundaries of the platted acquisitions, provide an overlay plat of the development site.**

1

<input type="text"/>	<input type="text"/>	<input type="text"/>	<input type="text"/>
Contract Number	Census Tract	Acreage	Date of Sale
<input type="text"/>		<input type="text"/>	
Street Address		City	
<input type="text"/>		<input type="text"/>	
Contact Name for Seller		Name of Seller Entity	
<i>Only list if owner has owned <36 mos.</i>		<i>Only list if owner has owned <36 mos.</i>	
<input type="text"/>		<input type="text"/>	
Contact Name for Previous Seller		Name of Previous Seller Entity	
<input type="text"/>		<input type="text"/>	
Seller Address		City	State Zip
<input type="text"/>		<input type="text"/>	<input type="text"/>

Did the seller acquire the property through foreclosure or deed in lieu of foreclosure?

Is the seller affiliated with the Applicant, Principal, sponsor, or Development Team?

If yes above, describe relationship:

Contract includes more than one tract/lot. Address, legal description, and acreage are below.

a.	<i>Address</i>	<i>Abbreviated Legal</i>	<i>Acres</i>
b.	<i>Address</i>	<i>Abbreviated Legal</i>	<i>Acres</i>
c.	<i>Address</i>	<i>Abbreviated Legal</i>	<i>Acres</i>

2

<input type="text"/>	<input type="text"/>	<input type="text"/>	<input type="text"/>
Contract Number	Census Tract	Acreage	Date of Sale
<input type="text"/>		<input type="text"/>	
Street Address		City	
<input type="text"/>		<input type="text"/>	
Contact Name for Seller		Name of Seller Entity	
<i>Only list if owner has owned <36 mos.</i>		<i>Only list if owner has owned <36 mos.</i>	
<input type="text"/>		<input type="text"/>	
Contact Name for Previous Seller		Name of Previous Seller Entity	
<input type="text"/>		<input type="text"/>	
Seller Address		City	State Zip
<input type="text"/>		<input type="text"/>	<input type="text"/>

Did the seller acquire the property through foreclosure or deed in lieu of foreclosure?

Is the seller affiliated with the Applicant, Principal, sponsor, or Development Team?

If yes above, describe relationship:

Contract includes more than one tract/lot. Address, legal description, and acreage are below.

a.	<i>Address</i>	<i>Abbreviated Legal</i>	<i>Acres</i>
b.	<i>Address</i>	<i>Abbreviated Legal</i>	<i>Acres</i>
c.	<i>Address</i>	<i>Abbreviated Legal</i>	<i>Acres</i>

If a revised form is submitted, date of submission:



**TEXAS DEPARTMENT OF
HOUSING & COMMUNITY AFFAIRS**
Building Homes. Strengthening Communities.

TAB 14

Elected Officials

Elected Officials

Elected officials were identified in the **Pre-Application** , and there have been no changes.
(If box above is checked, these forms may be left **BLANK** .)

Please identify all elected officials which represent the Development Site.

** US Representative District

<input type="text"/>	<input type="text"/>
State Senator	District
<input type="text"/>	
Support Letter	
<input type="text"/>	
<input type="text"/>	
City Mayor	

<input type="text"/>	<input type="text"/>
State Representative	District
<input type="text"/>	
Support Letter	
<input type="text"/>	
<input type="text"/>	
County Judge	

School Superintendent District Name Email

Address City Zip

Presiding officer of Board of Trustees Email

Address City Zip

** While Applicants are not required to notify US Representatives, the Department is required to notify them. Therefore, Applicant must identify the appropriate US Representative of the district containing the Development.

Elected Officials (Continued)

Reuben Marin	1	(979) 209-5000
City Council Member	District/Precinct	Email or Phone
Prentiss Madison	2	(979) 209-5000
City Council Member	District/Precinct	Email or Phone
Greg Owens	3	(979) 209-5000
City Council Member	District/Precinct	Email or Phone
Mike Southerland	4	(979) 209-5000
City Council Member	District/Precinct	Email or Phone
Ben Hardeman	5	(979) 209-5000
City Council Member	District/Precinct	Email or Phone
Buppy Simank	6	(979) 209-5000
City Council Member	District/Precinct	Email or Phone
Steve Aldrich	1	(979) 361-4106
County Commissioner	District/Precinct	Email or Phone
Sammy Catalena	2	(979) 361-4115
County Commissioner	District/Precinct	Email or Phone
Nancy Berry	3	(979) 361-4105
County Commissioner	District/Precinct	Email or Phone
Irma Cauley	4	(979) 361-4111
County Commissioner	District/Precinct	Email or Phone
	District/Precinct	Email or Phone
	District/Precinct	Email or Phone
	District/Precinct	Email or Phone



**TEXAS DEPARTMENT OF
HOUSING & COMMUNITY AFFAIRS**
Building Homes. Strengthening Communities.

TAB 15

Neighborhood Organizations

Neighborhood Organizations

Identify all Neighborhood Organizations on record with the county or Texas Secretary of State as of the beginning of the Application Acceptance Period whose boundaries include the Development Site.

- Organizations were identified in the Pre-Application, and there have been no changes.
(If above is checked, these forms may be left **BLANK**)

1.

Name of Organization		Contact Name
Address		City
Zip	Phone	Fax or Email

2.

Name of Organization		Contact Name
Address		City
Zip	Phone	Fax or Email

3.

Name of Organization		Contact Name
Address		City
Zip	Phone	Fax or Email

4.

Name of Organization		Contact Name
Address		City
Zip	Phone	Fax or Email

5.

Name of Organization		Contact Name
Address		City
Zip	Phone	Fax or Email

Neighborhood Organizations

Identify all Neighborhood Organizations on record with the county or Texas Secretary of State as of the beginning of the Application Acceptance Period whose boundaries include the Development Site.

- Organizations were identified in the Pre-Application, and there have been no changes.
 (If above is checked, these forms may be left **BLANK**)

1.

WE C U Civic Club of Bryan			
Name of Organization		Contact Name	
2002 Hwy 21 E.		Bryan	
Address		City	
77803			
Zip	Phone	Fax or Email	

2.

Name of Organization		Contact Name	
Address		City	
Zip	Phone	Fax or Email	

3.

Name of Organization		Contact Name	
Address		City	
Zip	Phone	Fax or Email	

4.

Name of Organization		Contact Name	
Address		City	
Zip	Phone	Fax or Email	

5.

Name of Organization		Contact Name	
Address		City	
Zip	Phone	Fax or Email	



**TEXAS DEPARTMENT OF
HOUSING & COMMUNITY AFFAIRS**
Building Homes. Strengthening Communities.

TAB 16

Certification of Notifications

CERTIFICATION OF NOTIFICATIONS (ALL PROGRAMS)

Pursuant to §10.203 of the Uniform Multifamily Rules, evidence of notifications includes this sworn affidavit, and the Elected Officials and Neighborhood Organizations Forms. All Applicants, or persons with signing authority, must complete Part 1 or Part 2 below:

Part 1. **Notifications made at Pre-Application (Competitive HTC only):**

I (We) certify that The pre-application included evidence of these notifications pursuant to §10.203 of the Uniform Multifamily Rules, the pre-application met all threshold requirements, and no additional notifications were required with this full application.

Re-notifications made at Application (Competitive HTC only):

The pre-application for this full Application met all threshold requirements, but all required entities were re-notified as required by §10.203 of the Uniform Multifamily Rules. As applicable, all changes in the Application have been made on the *Elected Officials and/or Neighborhood Organizations Form(s)*.

Notifications made at Application:

No pre-application was submitted, and all required entities were notified as required by §10.203 of the Uniform Multifamily Rules.

Part 2. **Notifications - Form and Content:**

I (we) certify that the notifications are not older than 3 months from the first day of the Application Acceptance Period for Competitive HTC Applications and not older than three (3) months prior to the date Parts 5 and 6 of the Application are submitted for Tax Exempt Bond Developments, and not older than three (3) months prior to the date the Application is submitted for all other Applications.

I (we) certify that the notifications do not contain any false or misleading statements. Without limiting the generality of the foregoing, the notification does not create the impression that the proposed Development will serve a Target Population exclusively or as a preference without such targeting or preference being documented in the Application and is or will be in full compliance with all applicable state and federal laws, including state and federal fair housing laws.

I (we) certify that the notifications or any other communications do not contain any statement that violates Department rules, statute, code, or federal requirements.

I (We) certify that, in addition to all of the required neighborhood organizations, the following entities were notified in accordance with §10.203 of the Multifamily Uniform Rules. The notifications were in the format provided in the *Application Notification Template*. All of the following entities were notified and are correctly listed on the *Elected Officials Form* and *Neighborhood Organizations Form*:

- Superintendent of the school district containing the Development;
- Presiding officer of the board of trustees of the school district containing the Development;
- Mayor of any municipality containing the Development;
- All elected members of the Governing Body of any municipality containing the Development;
- Presiding officer of the Governing Body of the county containing the Development;
- All elected members of the Governing Body of the county containing the Development;
- State senator of the district containing the Development; and
- State representative of the district containing the Development.

While not required to be submitted in this Application, I have kept evidence of all notifications made and this evidence may be requested by the Department at any time during the Application review.

Part 3. **No Neighborhood Organizations exist (competitive HTC only):**

I (We) certify that no Neighborhood Organizations exist for which this Application would be eligible to receive points under §11.9(d)(4) of the QAP or for which notification is required.

Part 4. Certification

By:

[Signature]
Signature of Applicant/Development Owner

Date

2.28.18

Rick Sims
Printed Name

Notarize on next page

CERTIFICATION OF NOTIFICATIONS (continued)

Louisiana
Notary Public, State of

at death
My Commission expires

Webster
County of
Parish

I, the undersigned, a Notary Public in and for said County and State, do hereby certify that name is signed to the foregoing statement, and who is known to be one in the same, has acknowledged before me on this date, that being informed of the contents of this statement, executed the same voluntarily on the date same foregoing statement bears.

GIVEN UNDER MY HAND AND SEAL OF OFFICE this

28th day of

February, 2018

[Signature]
Notary Public Signature

SHANNON M. RUPERT





**TEXAS DEPARTMENT OF
HOUSING & COMMUNITY AFFAIRS**
Building Homes. Strengthening Communities.

TAB 17

Development Narrative

Development Narrative

1. The proposed Development is: (Check all that apply)

New Construction

and/or:

(adaptive reuse select New Construction here and adaptive reuse in next box)

Previous TDHCA #

If Acquisition/Rehab or Rehab, original construction year:

If Reconstruction,

Units Demolished

Units Reconstructed

If Adaptive Reuse, Additional Phase, or Scattered Site, include detailed information in the Narrative (4.) below.

2. The Target Population will be:

Supportive Housing

Applicants seeking to be scored as Supportive Housing **must** select Supportive Housing as the population.

§10.3(46) If Elderly Preference is selected, complete the statement below and submit supporting documentation behind this tab.

Elderly Preference is based on funding from:

3. Staff Determinations regarding definitions of development activity obtained?

n/a

If a determination under §10.3(b) of the Uniform Multifamily Rules was made prior to Application submission, provide a copy of such determination behind this tab.

4. Narrative

Briefly describe the proposed Development, including any relevant information not already identified above.

This is a proposed 29 Units Supportive Housing project located in Bryan Texas. project consists of 30 detached units single family homes. The project deep target 13 units at 30 percent ami and 16 units at 80% of the ami. This units are exempt from the fair housing due to the units design. This project is planned for the person with disability population to have accessibilty and affordability.

If a revised form is submitted, date of submission:

5. Funding Request:

Complete the table below to describe this Application's funding request. If applying for Multifamily Direct Loan funds, please select only one type of loan.

Department Funds applying for with this Application	Requested Amount	If funds will be in the form of a Direct Loan by the Department or for Private Activity Bonds, the terms will be:		
		Interest Rate (%)	Amortization (Years)	Permanent Term (Years)
Multifamily Direct Loan: Const. to Perm. (Repayable)			30	
Multifamily Direct Loan: Construction Only (Repayable)				
Multifamily Direct Loan: Const. to Perm. (Soft Repayable)	\$2,000,000 \$ 1,000,000	0.00%		40
CHDO Operating Expenses Grant	\$ 50,000			
Housing Tax Credits				
Private Activity Mortgage Revenue				

6. §11.5 - Set-Aside (For Competitive HTC & Multifamily Direct Loan Applications Only)

Identify any and all set-asides the application will be applying under with an "x".
Set-Asides can not be added or dropped from pre-application to full Application for Competitive HTC Applications.

Competitive HTC Only				Multifamily Direct Loan Only			
At-Risk	Nonprofit	USDA		CHDO	SH/SR		
						x	

By selecting the set-aside above, I, individually or as the general partner(s) or officers of the Applicant entity, confirm that I (we) are applying for the above-stated Set-Aside(s) and Allocations. To the best of my (our) knowledge and belief, the Applicant entity has met the requirements that make this Application eligible for this (these) Set-Aside(s) and Allocations and will adhere to all requirements and eligibility standards for the selected Set-Aside(s) and Allocations.

7. Previously Awarded State and Federal Funding

Has this site/activity previously applied for TDHCA funds? Yes No

Has this site/activity previously received TDHCA funds? Yes No

If "Yes" Enter Project Number: 17069 and TDHCA funding source: _____

Has this site/activity previously received non-TDHCA federal funding? Yes No

If yes, source: _____

Will this site/activity receive non-TDHCA federal funding for costs described in this Application? Yes No

8. Qualified Low Income Housing Development Election (HTC Applications only)

Pursuant to §42(g)(1)(A) & (B), the term "qualified low income housing development" means any project or residential rental property, if the Development meets one of the requirements below, whichever is elected by the taxpayer." Once an election is made, it is irrevocable. Select only one:

- At least 20% or more of the residential units in such development are both rent restricted and occupied by individuals whose income is 50% or less of the area median gross income, adjusted for family size.
- At least 40% or more of the residential units in such development are both rent restricted and occupied by individuals whose income is 60% or less of the median gross income, adjusted for family size.

If a revised form is submitted, date of submission: _____



**TEXAS DEPARTMENT OF
HOUSING & COMMUNITY AFFAIRS**
Building Homes. Strengthening Communities.

TAB 18

Development Activities Part I

Development Activities

1. Common Amenities (ALL Multifamily Applications §10.101(b)(5))

of Units must qualify for Points

Development will provide sufficient common amenities to qualify for the number of points indicated above, pursuant to §10.101(b)(5) of the Uniform Multifamily Rules. Applications for scattered site developments should refer to §10.101(b)(5)(B) of the Uniform Multifamily Rules.

2. Unit Requirements (ALL Multifamily Applications §10.101(b)(6)(A) and (B))

A. Unit Sizes

Development is New Construction or Reconstruction and will meet the minimum Unit Size requirements:

Bedroom Size	0	1	2	3	4
Square Footage	500	600	800	1,000	1,200

OR:

Development is proposing Rehabilitation (excluding Reconstruction) or Supportive Housing, and does not adhere to the size requirements above.

B. Unit Amenities (For Competitive HTC Applications, see Tab 19 for Unit and Development Features)

Application is a Tax Exempt Bond Development and will meet a minimum of seven (7) points as outlined in §10.101(b)(6)(B) of the Uniform Multifamily Rules.

Application is HOME only or other Department Direct Loan and will meet a minimum of four (4) points as outlined in §10.101(b)(6)(B) of the Uniform Multifamily Rules.

**** Rehabilitation Developments will start with a base score of three (3) points and Supportive Housing Developments will start with a base score of five (5) points.****

3. Tenant Supportive Services (For Competitive HTC Applications and Direct Loan Applications seeking to qualify for points under §13.6, see Tab 19 for Tenant Services elections)

Application is a **Tax Exempt Bond Development** and will meet a minimum of eight (8) points as outlined in §10.101(b)(7) of the Uniform Multifamily Rules.

Application is **only requesting Direct Loan funds** and will meet a minimum four (4) points as outlined in §10.101(b)(7) of the Uniform Multifamily Rules.

4. Development Accessibility Requirements (ALL Multifamily Applications)

Development will meet all specifications and accessibility requirements reflected in the Certification of Development Owner form pursuant to §10.101(b)(8) of the Uniform Multifamily Rules.

Yes

All Units accessed by the ground floor or by elevator ("affected units") comply with the visitability requirements in clauses (i) – (iii) of 10 TAC §10.101(b)(8)(B).

and

Development will meet all specifications and accessibility requirements reflected in 10 TAC Chapter 1, Subchapter B, §1.207.

Yes

Development has a minimum of 5% of all units in the development set aside for the mobility impaired and an additional 2% set aside for the hearing and/or visually impaired.

Regardless of building type, all Units accessed by the ground floor or by elevator ("affected units") must comply with the visitability requirements in clauses (i) – (iii) of 10 TAC §10.101(b)(8)(B).



**TEXAS DEPARTMENT OF
HOUSING & COMMUNITY AFFAIRS**
Building Homes. Strengthening Communities.

TAB 19

Development Activities Part II

Development Activities (Continued)

self score 35

1. Size and Quality of Units (Competitive HTC Applications only) [§11.9(b)]

Development is Rehabilitation and either Supportive Housing or USDA financed OR meets the minimum size requirements identified below: Points claimed: 0

Bedroom Size	0	1	2	3	4
Square Footage	550	650	850	1,050	1,250

Specific amenities and quality features will be provided in every Unit at no extra charge to the tenant; Development will maintain the points selected and associated with those amenities as outlined in §10.101(b)(6)(B) of the Uniform Multifamily Rules.* Points claimed: 0

** Direct Loan applicants proposing new construction or rehabilitation should be prepared to comply with requirements of the newly published Federal rule at 81 FR 92626, which requires installation of broadband infrastructure at the time of new construction or substantial rehabilitation of multifamily rental housing that is funded or supported by HUD.*

2. Rent Levels of Tenants and Tiebreaker (Direct Loan Applications only) [§13.6(e) and (f)]

At least 20 percent of all low-income Units at 30% or less of AMGI* Direct Loan Points: 13

At least 10 percent of all low-income Units at 30% or less of AMGI or, for a Development located in a Rural Area, 7.5 percent of all low-income Units at 30% or less of AMGI* Direct Loan Points: 0

At least 5 percent of all low-income Units at 30% or less of AMGI* Direct Loan Points: 0

In the event of a tie with another application or applications, this percentage of 30% AMGI MFDL units within the Development would be converted to be available to households at 15% AMGI.

** Applicants electing to restrict units at 30% AMGI for Competitive HTC purposes may not count those units for point scoring under §13.6(e). However, 50% AMGI and 60% AMGI units that are layered with 30% AMGI units for Direct Loan purposes may count for point scoring under §13.6(e). Points claimed here will not appear on the Self Score tab.*

3. Income Levels of Tenants (Competitive HTC Applications only) [§11.9(c)(1)]

0 Total Number of Units at 50% or less of AMGI

Number of 30% Units used to score points under §11.9(c)(2)* CHECK YOUR MATH!

Number of 30% Units used under §11.4(c)(3)(D) regarding an Increase in Eligible Basis (30% boost)

0 Number of Units at 50% or less of AMGI available to use for points under §11.9(c)(1)

0.00% Percentage used for calculation of eligible points under §11.9(c)(1)

Mark **only one** box below:

Development is located in a Non-Rural Area of the Dallas, Fort Worth, Houston, San Antonio or Austin MSA; or Points Claimed: 0

Developments proposed in all other areas. Points Claimed: 0

** Applicants electing the 30% boost for additional 30% units are advised to ensure the units used to support the boost are not included in the units needed to achieve the Application's scoring elections.* Points Claimed: 0

4. Rent Levels of Tenants (Competitive HTC Applications only) [§11.9(c)(2)]

Mark **only one** box below:

At least 20% (less Units used for eligibility for boost) of all low-income Units are restricted at 30% or less of AMGI; development is Supportive Housing proposed by a Qualified Nonprofit Organization. Points Claimed: 0

Development is urban and at least 10% (less Units used for eligibility for boost) of all low-income Units are restricted at 30% or less of AMGI; or Points Claimed: 0

Development is located in a Rural Area and 7.5% (less Units used for eligibility for boost) of all low-income Units are restricted at 30% or less of AMGI; or Points Claimed: 0

At least 5% of all low-income Units at 30% or less of AMGI Points Claimed: 0

Points Claimed: 0

5. Tenant Services (Competitive HTC Applications and Direct Loan Applications) [§11.9(c)(3) and §13.6(6)]

Development will provide a combination of supportive services as identified in §10.101(b)(7) and those services will be recorded in the Development's LURA.

Supportive Housing Development proposed by a Qualified Nonprofit Points Claimed: 10

All other Developments. Points Claimed: 0

The Applicant certifies that the Development will contact local service providers, and will make Development community space available to them on a regularly-scheduled basis to provide outreach services and education to the tenants. Points Claimed:

6. Tenant Populations with Special Housing Needs (Competitive HTC, MFDL, and Section 811 Applications) [§11.9(c)(7); §13.6(6)]

Applicants scoring points under the Section 811 PRA program should pay close attention to the URA requirements included in Tab 21, Davis Bacon requirements under TAB 44 and the environmental clearance requirements included in Tab 47.

If pursuing these points, Applicants must try to score first with subparagraph (A) and then subparagraph (B). Only if an Applicant or Affiliate cannot meet the requirements of subparagraphs (A) or (B) may an Application qualify for points under subparagraph (C). Select **only one** scoring scenario below:

A Applicant or Affiliate Owns or Controls an **Existing Development** that is included on the List of Eligible Existing Developments for Participation in the Section 811 PRA Program (See 10 TAC §8.3 and 10 TAC 8.4)

Existing Development Name: _____ TDHCA #: _____

Attached behind this tab is the executed Certification for Section 811 PRA Program Participation. Points Claimed:

OR

B If not scoring under A above, Applicant or Affiliate is committing at least 10 Units in the proposed Development for participation in the Section 811 PRA Program

Applicant or Affiliate has attached behind this tab an explanation and documentation regarding the Applicant's or Affiliate's lack of Ownership interest or Control of any Existing Development that is included on the List of Qualified Existing Developments for Multifamily Programs:

AND

Attached behind this tab is the executed Certification for Section 811 PRA Program Participation. Points Claimed:

OR

C If cannot score under A or B above, Applicant elects to set-aside at least 5 percent of the total Units for Persons with Special Needs. **MFDL Applications that are not layered with 2018 9% HTC cannot elect to score points under this item.** The Department will require an initial minimum twelve-month period during which Units must either be occupied by Persons with Special Needs or held vacant, unless the units receive HOME funds from any source.

Applicant or Affiliate has attached behind this tab an explanation and documentation regarding the Applicant's or Affiliate's lack of Ownership interest or Control of any Existing Development that is included on the List of Qualified Existing Developments for Multifamily Programs; and the Development applying for funding has a disqualifying factor described below:

Mark **any** of the following factors that disqualify the development applying for funding from participating in the Section 811 PRA Program and provide documentation supporting the selection:

The Development is not proposing to use and previously did not use federal funding (such as HOME or CDBG funds), and the Development was originally constructed before 1978;

Development only has units available that have existing or proposed project-based rental or long-term operating assistance that will be in effect when the property is operating or within six months of receiving Section 811 PRA Program assistance;

Development only has units available that are restricted for persons with disabilities.

A Development having a **preference** for Persons with Disabilities or a use restriction for Special Needs Populations is **not a disqualifying factor** for purposes of this scoring item.

Development only has units with an existing or proposed 62 or more age restriction.

Development is not located in Austin-Round Rock MSA, Brownsville-Harlingen MSA, Corpus Christi MSA, Dallas-Fort Worth-Arlington MSA, El Paso MSA, Houston-The Woodlands-Sugar Land MSA, McAllen-Edinburg-Mission MSA, or San Antonio-New Braunfels MSA.

The Development is a new construction project and located in the mapped 500-year floodplain or in the 100-year floodplain according to FEMA's most current Flood Insurance Rate Maps.

The Development is located in a coastal high hazard area (V Zone) or regulatory floodway.

Other disqualifying factor (please explain) _____

Points Claimed:

Application is seeking points for Tenant Populations. Points Claimed:

7. **Pre-Application Participation (Competitive HTC Applications only) [§11.9(e)(3)]**

Development is requesting Pre-Application Points.

8. **Extended Affordability (Competitive HTC Applications only) [§11.9(e)(5)]**

Development will maintain a 35 year Affordability Period.

9. **Historic Preservation (Competitive HTC Applications only) [§11.9(e)(6)]**

Application requests points for Historic Preservation.

Application contains a letter from the Texas Historical Commission (THC) determining preliminary eligibility for federal or state historic (rehabilitation) tax credits.

Application includes documentation from the Texas Historical Commission that the property is currently a Certified Historic Structure or determining preliminary eligibility for status as a Certified Historic Structure.

Development will be able to document receipt of historic tax credits by the time Forms 8609 are issued.

At least 75% of the residential units will be within the Certified Historic Structure.

Attached behind this tab are the THC letter and other documentation described above.

Application is eligible for five (5) points. 

10. **Right of First Refusal (Competitive HTC Applications only) [§11.9(e)(7)]**

Development Owner agrees to provide a Right of First Refusal to purchase the Development upon or following the end of the Compliance Period.

11. **Funding Request Amount (Competitive HTC Applications only) [§11.9(e)(8)]**

Application reflects funding request for no more than 100% of the amount available in the subregion or set-aside as of 12/5/2017.



**TEXAS DEPARTMENT OF
HOUSING & COMMUNITY AFFAIRS**
Building Homes. Strengthening Communities.

TAB 20

Acquisition and Rehabilitation Information

EXISTING DEVELOPMENT INFORMATION

1. At-Risk Set-Aside (*Competitive HTC Applications Only*) [§11.5(3)]

- Qualification: Must meet the requirements of an At-Risk Development in §11.5(3) of the Qualified Allocation Plan. Documentation must be submitted behind this tab showing that the Development meets the requirements of Texas Government Code §2306.6702(a)(5) and §11.5(3) of the 2017 Qualified Allocation Plan.

PART A: DOCUMENTATION MUST SHOW THAT THE SUBSIDY OR BENEFIT IS FROM ONE OF THE FOLLOWING APPROVED PROGRAMS (mark all that apply):

- Sections 221(d)(3) and (5), National Housing Act (12 U.S.C. Section 1715l)
- Section 236, National Housing Act (12 U.S.C. Section 1715z-1)
- Section 202, Housing Act of 1959 (12 U.S.C. Section 1701q)
- Section 101, Housing and Urban Development Act of 1965 (12 U.S.C. Section 1701s)
- The Section 8 Additional Assistance Program for housing developments with HUD-Insured and HUD-Held Mortgages administered by the U.S. Department of Housing and Urban Development as specified in 24 CFR Part 886, Subpart A.
- The Section 8 Housing Assistance Program for the Disposition of HUD-Owned Projects administered by the U.S. Department of Housing and Urban Development as specified by 24 CFR Part 886, Subpart C.
- Sections 514, 515, and 516, Housing Act of 1949 (42 U.S.C. Sections 1484, 1485 and 1486)
- Section 42, of the Internal Revenue Code of 1986 (26 U.S.C. Section 42)

IN ADDITION, THE SUBSIDY OR BENEFIT IS SUBJECT TO THE FOLLOWING CONDITIONS (mark all that apply):

- The stipulation to maintain affordability in the contract granting the subsidy is nearing expiration (i.e. expiration will occur within two (2) calendar years of July 31, 2018). See §11.5(3)(E) and (F) of the 2018 QAP concerning At-Risk developments qualifying under Section 42 of the Internal Revenue Code.
- The subsidy marked above is a HUD-insured or HUD-held mortgage nearing the end of its mortgage term (the term will end within two (2) calendar years of July 31, 2018), **AND** the mortgage is eligible for prepayment or has been prepaid.

PART B: DOCUMENTATION MUST SHOW THAT THE APPLICATION PROPOSES TO REHABILITATE OR RECONSTRUCT HOUSING UNITS THAT:

- Are owned by a public housing authority or a public facility corporation created by a public housing authority under Chapter 303, Local Government Code and receive assistance under Section 9, United States Housing Act of 1937 (42 U.S.C. Section 1437g); **OR**
- Received assistance under Section 9, United States Housing Act of 1937 (42 U.S.C. Section 1437g) **AND**
- Are proposed to be disposed of or demolished by a public housing authority or a public facility corporation created by a public housing authority under Chapter 303, Local Government Code; **OR**
- Were disposed of or demolished within the 2 years preceding the application by a public housing authority or a public facility corporation created by a public housing authority under Chapter 303, Local Government Code; **OR**
- Receive assistance or will receive assistance through the Rental Assistance Demonstration (RAD) program of HUD as specified by the Consolidated and Further Continuing Appropriations Act of 2012 (Pub. L. No. 112-55) and its subsequent amendments, if the application for assistance through RAD is included in the applicable public housing authority's plan that was most recently approved by HUD as specified by 24 C.F.R. Section 903.23.

PART C: THE APPLICATION PROPOSES RELOCATION OF EXISTING UNITS IN AN OTHERWISE QUALIFYING AT-RISK DEVELOPMENT AND DOCUMENTATION MUST SHOW THAT:

- The affordability restrictions and any At-Risk eligible subsidies are approved to be transferred with the Units proposed for Rehabilitation or Reconstruction prior to the tax credit Carryover deadline; **AND**
- The Application proposes the same number of restricted units;
AND EITHER

At-Risk Set-Aside (continued)

The new Development Site qualifies for points under §11.9(c)(4) related to Opportunity Index; **OR**

The local Governing Body of the applicable municipality or county (if completely outside of a municipality) in which that Development is located must submit a resolution confirming that the proposed Development is supported by the municipality or county in order to carry out a previously adopted plan that meets the requirements of §11.9(d)(7) related to Concerted Revitalization Plans.

PART D: REGULATORY BARRIERS NECESSITATE ELIMINATION OF ALL OR A PORTION OF THE FINANCIAL BENEFIT FOR THE DEVELOPMENT, AND:

Evidence of the legal requirements that will unambiguously cause the loss of affordability is included.

Development qualifies under §2306.6702(a)(5)(B); **AND**

No less than 25 percent of the proposed Units are public housing units supported by public housing operating subsidy, **AND**

Less than 100 percent of the public housing benefits are being transferred to the proposed Development and the Application includes an explanation of the disposition of the remaining public housing benefits along with a copy of the HUD-approved plan for demolition and disposition.

PART E: THE PROPOSED DEVELOPMENT IS ELIGIBLE TO REQUEST A QUALIFIED CONTRACT UNDER §42, AND THE APPLICATION INCLUDES:

A copy of the recorded LURA and the first years' IRS Forms 8609 for all buildings showing Part II of the form completed; **AND**

If applicable, documentation from the original application regarding the right of first refusal.

Applications proposing the demolition and Reconstruction of Units will be considered New Construction.

2. Existing Development Assistance On Housing Rehabilitation Activities¹

Part A.

The existing Property is expected to have or continue the following benefit:

Provide a brief description of the restrictions or subsidies the existing Property will have or continue in the space below:

A copy of the contract or agreement securing the funds identified above is provided behind this form.

The source of funds is:

The annual amount of funds is:

The number of units receiving assistance:

The term of the contract or agreement is (date):

The expiration of the contract or agreement is (date):

Part B. Acquisition Of Existing Buildings (applicable only to HTC applications with Acquisition credits requested)

Date of the most recent sale or transfer of the building(s):

In the last ten years, did the previous owner perform rehabilitation work greater than 25% of the building's adjusted basis?

Was the building occupied at any time during the last ten years?

Was the building occupied or suitable for occupancy at the time of purchase?

Will the acquisition meet the requirements of §42(d)(2)(B)(ii) relating to the 10-year placed in service rule?

If "Yes", provide a copy of a title commitment that the Development meets the requirements of §42(d)(2)(B)(ii) as to the 10 year period.

If "No", does the property qualify for a waiver under §42(d)(6)?

If "Yes", provide the waiver and/or other documentation.

How many buildings will be acquired for the Development? 

Existing Development Assistance (continued)

Are all the buildings currently under control by the Development Owner?

If "No", how many buildings are under control by the Development Owner?

When will the remaining buildings be under control?

¹Per §2306.008, TDHCA shall support the preservation of affordable housing for individuals with special needs and individuals and families of low income at any location considered necessary by TDHCA.

Identification or address(es) of Building(s) under Owner's Control	Type of Control (Ownership, Option, Purchase Contract)	Expiration Date	# of Units	Acquisition Cost of Building

Provide the information listed below concerning the acquisition of building(s) for the Development:

1. Building(s) acquired or to be acquired from: Related Party Unrelated Party

2. Building(s) acquired or to be acquired with Buyer's Basis:

Determined with reference to Seller's Basis Not Determined with reference to Seller's Basis

List below by building address, the date the building was placed in service (PIS), the date the building was or is planned for acquisition, and the number of years between the date the building was placed in service and acquisition. Attach separate sheet(s) with additional information if necessary.

Building Address(es)	PIS date of building by most recent owner	Proposed Acquisition date by the Applicant	Years between PIS & Acquisition

3. Lead Based Paint (Direct Loan Applications Only)

Development constructed before January 1, 1978

Check each of the following that applies [24 CFR 35.115]:

Emergency repairs to the property are being performed to safeguard against imminent danger to human life, health or safety, or to protect the property from further structural damage due to natural disaster, fire or structural collapse. The exemption applies only to repairs necessary to respond to the emergency.

The property will not be used for human residential habitation. This does not apply to common areas such as hallways and stairways of residential and mixed-use properties.

Housing "exclusively" for the elderly or persons with disabilities, with the provision that children less than six years of age will not reside in the dwelling unit.

An inspection performed according to HUD standards found the property contained no lead-based paint.

According to documented methodologies, lead-based paint has been identified and removed; and the property has achieved clearance.

The rehabilitation will not disturb any painted surface.

The property has no bedrooms.

The property is currently vacant and will remain vacant until demolition.



**TEXAS DEPARTMENT OF
HOUSING & COMMUNITY AFFAIRS**
Building Homes. Strengthening Communities.

TAB 21

Occupied Rehabilitation

Occupied Developments

Pursuant to §10.204(8)(G) of the Uniform Multifamily Rules, for any Application where any structure on the Development Site is occupied at any time after the beginning of the Application Acceptance Period, even if demolition is proposed, the following items must be provided.

- Historical monthly operating statements of the Development for twelve (12) consecutive months ending no more than three (3) months from the first day of the Application Acceptance Period; or
 - The two (2) most recent consecutive annual operating statement summaries; or 
 - The most recent consecutive six (6) months of operating statements and the most recent available annual operating summary; or
 - All monthly or annual operating summaries available.
- AND**
- A rent roll not more than six (6) months old as of the first day of the Application Acceptance Period that discloses the terms and rate of the lease, rental rates offered at the date of the rent roll, Unit mix, and tenant names or vacancy; and
 - A written explanation of the process used to notify and consult with the tenants in preparing the Application; (§2306.6705(6)); and
 - If applicable, evidence that the relocation plan has been submitted to the appropriate legal or governmental agency. (§2306.6705(6)); and
 - A relocation plan outlining relocation requirements and a budget with an identified funding source that clearly describes relocation process, actions, and costs to the displaced and those not (§2306.6705(6)).
 - Optional, but only available to developments with no Section 811 PRA or Direct Loan funds. The current property owner is unwilling to provide one or more of the required documents above, and a signed statement from the Applicant attesting to that fact is submitted behind this tab.

Uniform Relocation Act (URA) Applicability for Section 811 PRA and Direct Loan Applications

- Participation in the Section 811 PRA program is by way of the occupied Rehabilitation (including reconstruction or Adaptive Reuse) Development proposed in the Application.
- Participation in the Section 811 PRA program is by way of the New Construction Development proposed in the Application, and includes the demolition of an occupied structure (e.g. single family house or mobile home).
- Application includes a request for Direct Loan funding (except for Supportive Housing and Soft Repayment TCAP-RF only).

(if none of the three boxes above is checked, you may skip the remainder of this section)

Each of the following items, as applicable, is provided behind this tab:

- Identification of any business, nonprofit organization, or farm on the site (that is not owned or controlled by the Seller);
- Dated General Information Notice(s) given to current occupants (other than owner occupied structures) including verification of tenant receipt;
- Dated Voluntary Acquisition Notification to Owner; and 
- HUD Relocation Brochure issued to tenants that will be displaced (if known).

Relocation Certification for Section 811 PRA and Direct Loan Applications

The New Construction, Rehabilitation (including Adaptive Reuse), or demolition and Reconstruction of the proposed Development must be carried out in accordance with policies and procedures governing implementation of the Uniform Relocation Assistance and Real Property Acquisition Policies Act of 1970 ("URA"), as amended, for the Section 811 PRA program under (49 CFR Part 24); and for Direct Loans under the Section 104(d) of the Housing and Community Development Act of 1974 ("Section 104(d)), and the optional relocation policies adopted pursuant to 24 CFR 92.253(d).

A displaced person, business, farm, or nonprofit is covered under URA, regardless of income, if they are displaced by acquisition, rehabilitation, or demolition.

Signature of Applicant

Printed Name

Date

Relocation Certification for Direct Loan Applications

For Direct Loan Applications (except for Supportive Housing and Soft Repayment Funds, which do not have to complete the rest of this section): A displaced person is covered under Section 104(d) if they are a low-income person displaced by demolition (including acquisition involving demolition) OR conversion (if market rent of the dwelling did not exceed the fair market rent before conversion).

Check all that apply:

- The activity involves demolition of existing occupied structures.
- The activity involves conversion of occupied rental property occupied by any tenant.

Applicants for Direct Loan funds that plan to rehabilitate, demolish and/or reconstruct occupied housing units must comply with the Section 104(d). By signing below, the Applicant certifies that they will comply with the Residential Anti-Displacement and Relocation Assistance Plan (RARAP) approved by the Department on June 1, 2012.

The RARAP, as approved follows the Housing and Community Development Act of 1974, and HUD regulations at 24 CFR §42.325. The Department, through its subgrantees, will offer relocation assistance for lower-income tenants who, in connection with an activity assisted under a Direct Loan move permanently or move personal property from real property as a direct result of the demolition of any dwelling unit or the conversion of a lower-income dwelling unit in accordance with the requirements of 24 CFR §42.350

The purpose and goals of the RARAP is to:

- (1) Provide (through its subgrantees) Relocation Assistance
- (2) Minimize Displacement
- (3) Ensure a One-for-One Replacement of Lower-Income Dwelling Units

I (we) certify that I (we) have read and understand the Department's approved Residential Anti-Displacement and Relocation Assistance Plan (RARAP), and I (we) will comply will all parts of the plan as they apply to this Application.

Signature of Applicant

Printed Name

Date



**TEXAS DEPARTMENT OF
HOUSING & COMMUNITY AFFAIRS**
Building Homes. Strengthening Communities.

TAB 22

**Architectural
Drawings**

Architectural Drawings Must be Submitted Behind this Tab [§10.204(b)(9)]

(If development is scattered site, consult staff.)

- Site Plan which:
 - states the size of the site on its face
 - includes a unit and building type table matrix that is consistent with the Rent Schedule and Building and Unit Configuration forms in labeling the buildings, stating sizes, etc.
 - identifies all residential and common buildings and labels them consistently with the Building/Unit Type Configuration form
 - clearly delineates the flood plain boundary lines or states there is no floodplain
 - identifies all easements, regardless of how they are held
 - indicates placement of detention/retention pond(s) or states there are no detention ponds
 - indicates the location and number of parking spaces, garages and carports
 - indicates the location and number of accessible parking spaces (review application webinar)
 - includes information regarding local parking requirements
 - indicates compliant accessible routes
 - includes a unit and building type table matrix that indicates the distribution of accessible Units
 - describes if applicable how flood mitigation or other required mitigation will be accomplished.
- Residential Building floor plans should include the following, building by building:
 - separate tabulation of the square footage of each of these areas: breezeways, corridors, utility closets, porches and patios, and any other square footage not included in NRA
 - location of accessible units
- Common Building floor plans should include the following, building by building:
 - tabulation of the square footage of conditioned (heated and cooled) spaces that are accessible to tenants, e.g., offices for tenant/management contact, clubrooms, kitchens, exercise rooms, laundries, etc. (state each area separately).
 - tabulation of the square footage of conditioned areas that are restricted to employees, only, e.g., administrative offices, maintenance areas, etc. (state each area separately).
 - tabulation of the square footage of unconditioned areas that are accessible to tenants, e.g., porches, patios, mailbox areas, etc. (state each area separately)
 - tabulation of the square footage of unconditioned areas that are restricted to employees, only, e.g., maintenance areas, equipment rooms, storage, etc. (state each area separately)
 - For Supportive Housing only**, specification of space to be used for 50 sq ft/unit common space
- Unit floor plans for each type of Unit
 - 5% of each Unit type are accessible to tenants with a mobility impairment, and 2% are accessible to tenants with a vision or hearing impairment
 - All Units accessed by the ground floor or by elevator comply with the visitability requirements of 10.101(b)(8)(B)(iii)
- Elevations for each side of each building type and must include:
 - a percentage estimate of the exterior composition of each elevation
 - roof pitch
- Photos of building elevations (Rehab and Adaptive Reuse not altering the unit configuration)

SITE PLAN NOTE:

A) THE HCP UNITS REPRESENT 5% OF THE UNITS REQUIRED TO BE MOBILITY ACCESSIBLE.

B) THE HEARING/VISUAL ACCESSIBLE UNITS REPRESENT 2% REQUIRED

C) SITE PLAN MATERIALLY ADHERES TO ALL APPLICABLE ZONING, SITE DEVELOPMENT, AND BUILDING CODE ORDINANCES

UNIT LABEL	# OF BEDROOMS	# OF BATHROOMS	SQ. FT. PER UNITS	# OF UNITS	TOTAL SQ. FT. PER UNITS	TOTAL SQ. FT. FOR ALL UNITS
1R3	3	2	1,070	14	14,980	
1R4	3	2	1,140	15	17,100	32,080

BUILDING LABEL	1R3	1R4	TOTAL OF BUILDINGS
# OF STORIES	1	1	
# OF BUILDINGS	14	15	29

TOTAL OF LOTS 29

DEVELOPED ACREAGE: 4.18 ACRES
 TOTAL ACREAGE FOR ENTIRE SITE: 6.19 ACRES

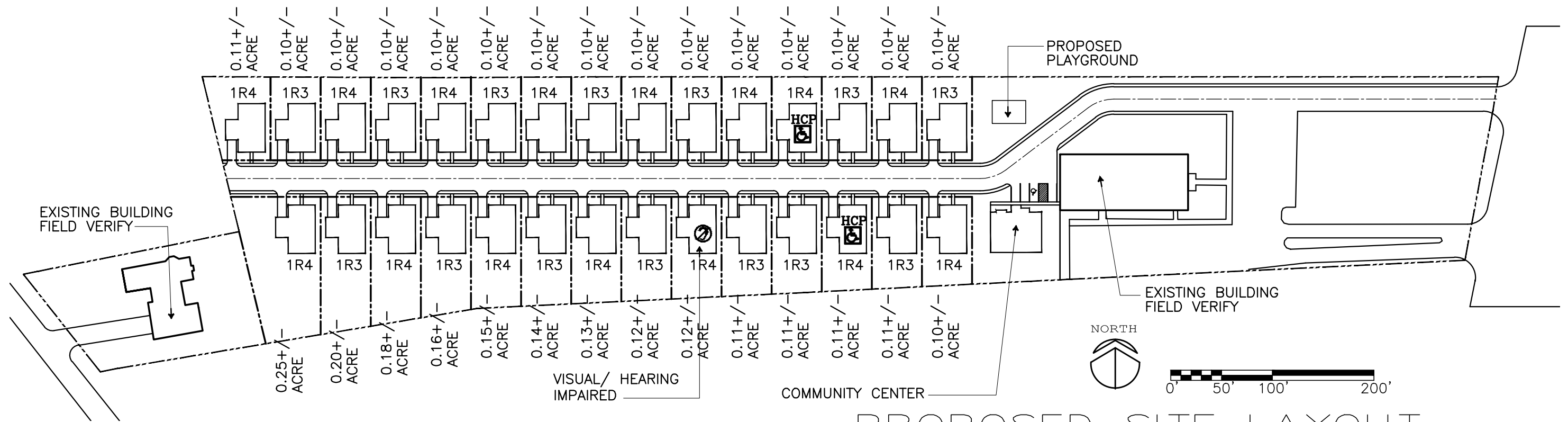

PROPOSED SITE LAYOUT

SCALE: 1"=100'-0"

©LUBULA KANYINDA COPYRIGHTS 2017

PROJECT TITLE:

HOUSING PROJECT

STREET # ADDRESS
 BRYAN, TEXAS

KANYINDA LLC

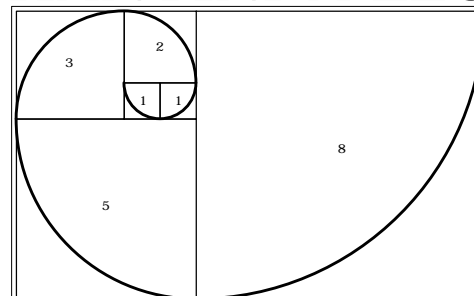

RESIDENTIAL & LAND DEVELOPMENT CONSULTANCY

7420 FRONT LAKE TRAIL
 ARLINGTON, TEXAS 76002
 PH: 682.551.6960

EMAIL: dixon.kanyinda@live.com

SHEET#:

DRAWN BY:

PROJ DESIGNER:

PROJ COORD.:

SITE

COMMUNITY CENTER AREA DATA:

AIR CONDITIONED SPACE: 1,690 SQ. FT.
 COVERED TERRACE: 275 SQ. FT.

 TOTAL GROSS SQ. FT.: 1,965 SQ. FT.

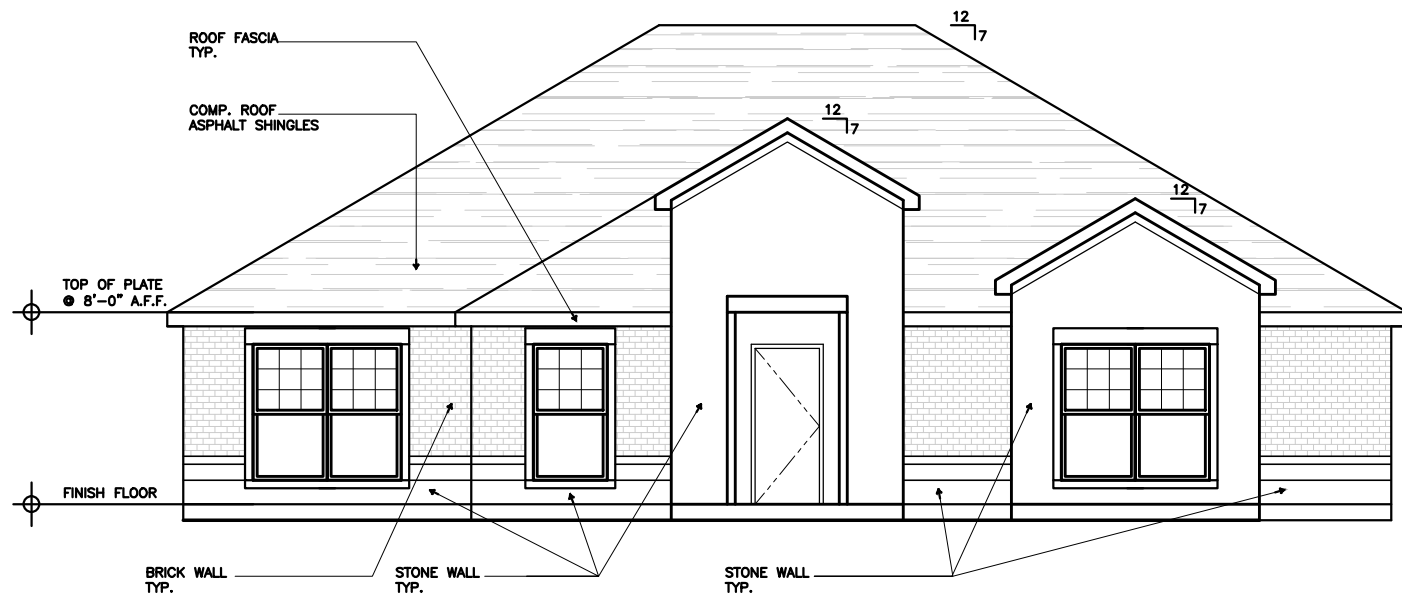

FRONT ELEVATION

SCALE: 1/8"=1'-0"

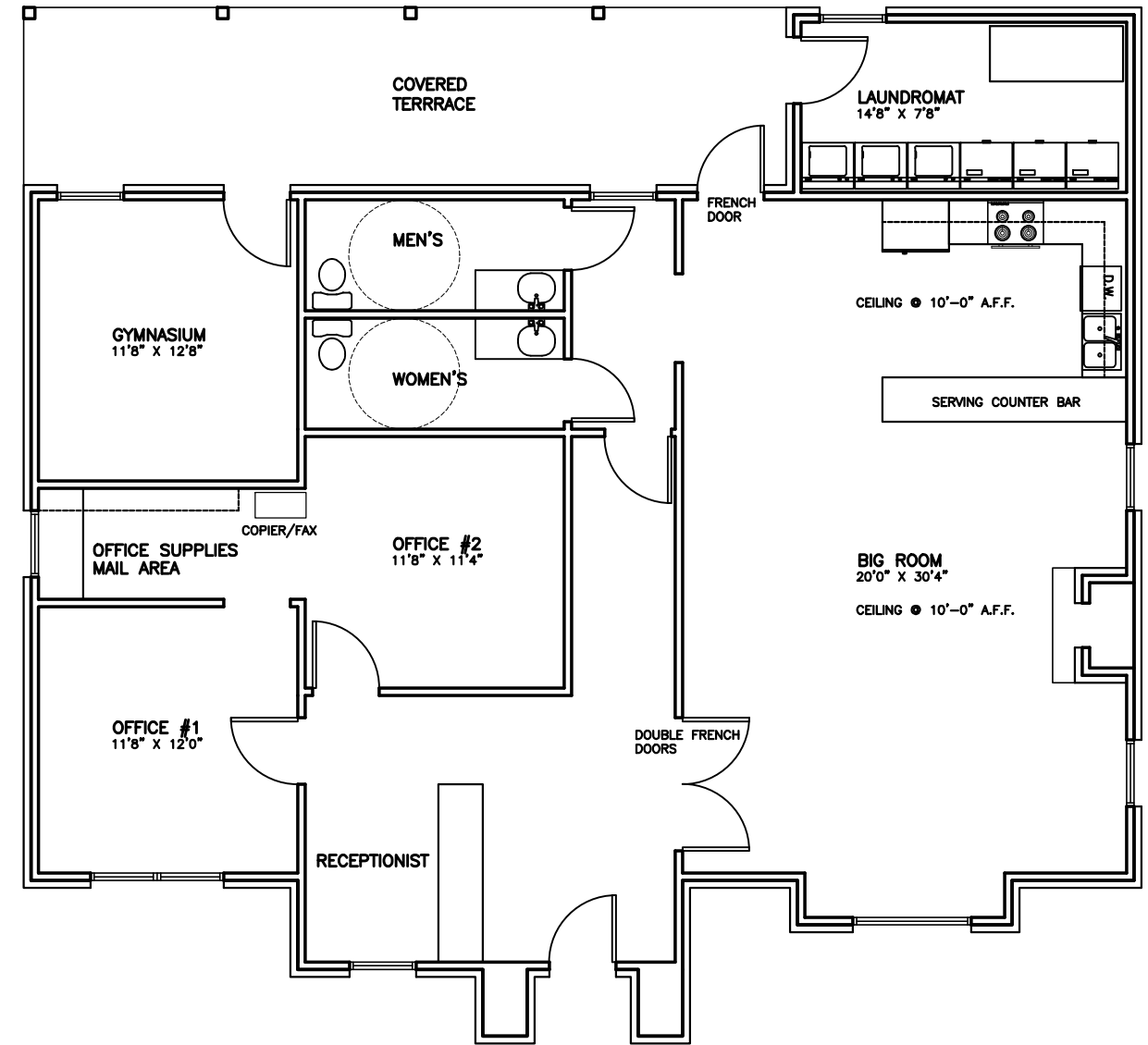

FLOOR PLAN

SCALE: 1/8"=1'-0"

©LUBULA KANYINDA COPYRIGHTS 2017

PROJECT TITLE:

HOUSING PROJECT

STREET # ADDRESS
 BRYAN, TEXAS

KANYINDA LLC

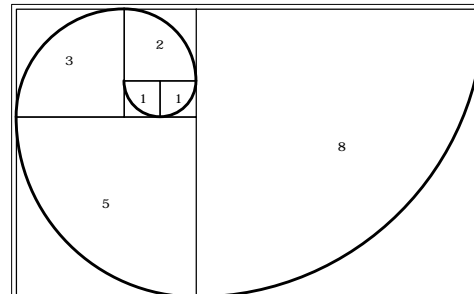

RESIDENTIAL & LAND DEVELOPMENT CONSULTANCY

7420 FRONT LAKE TRAIL
 ARLINGTON, TEXAS 76002
 PH: 682.551.6960

EMAIL: dixon.kanyinda@live.com

DRAWN BY:

PROJ DESIGNER:

PROJ COORD.:

SHEET#:

1

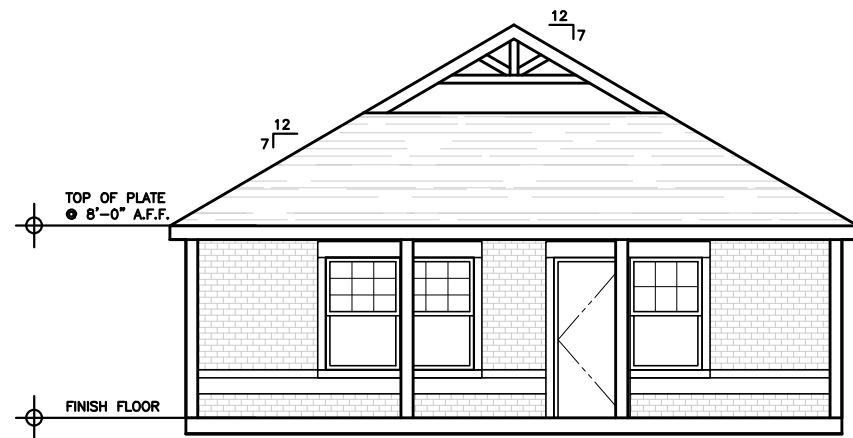

HOUSE DATA:

AIR CONDITIONED SPACE:	1,070 SQ. FT.
FRONT PORCH:	164 SQ. FT.
CAR PORT:	240 SQ. FT.
TOTAL GROSS SQ. FT.:	1,474 SQ. FT.

FRONT ELEVATION

SCALE: 1/8" = 1'-0"

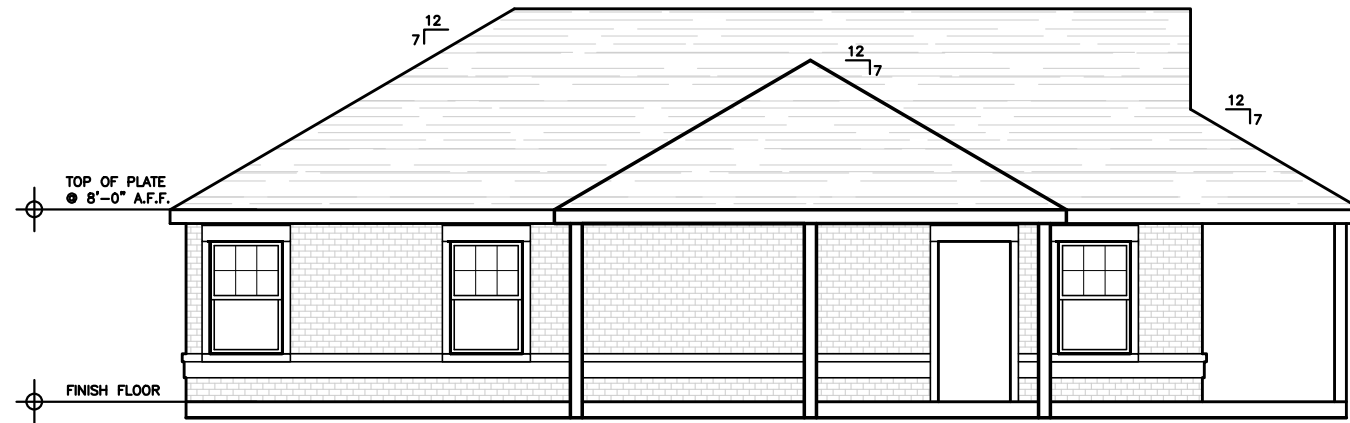

SIDE ELEVATION (SIM.)

SCALE: 1/8" = 1'-0"

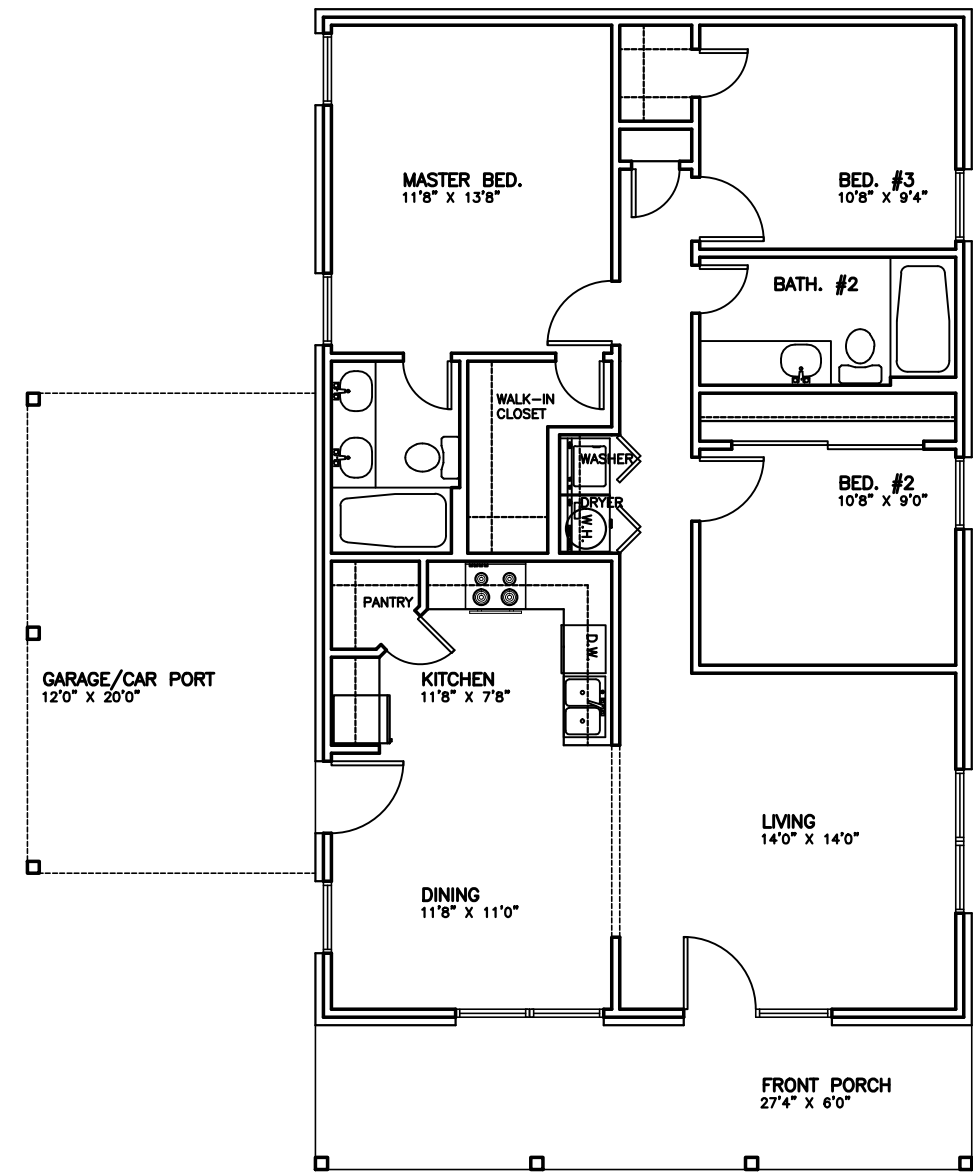

FLOOR PLAN

MODEL # 1R3

SCALE: 1/8" = 1'-0"

©LUBULA KANYINDA COPYRIGHTS 2017

PROJECT TITLE:

HOUSING PROJECT

STREET # ADDRESS
BRYAN, TEXAS

KANYINDA LLC

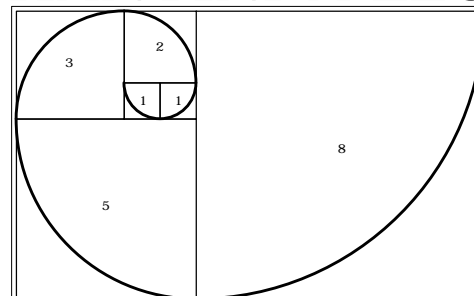

RESIDENTIAL & LAND DEVELOPMENT CONSULTANCY

7420 FRONT LAKE TRAIL
ARLINGTON, TEXAS 76002
PH: 682.551.6960

EMAIL: dixon.kanyinda@live.com

DRAWN BY:

PROJ DESIGNER:

PROJ COORD.:

SHEET#:

2

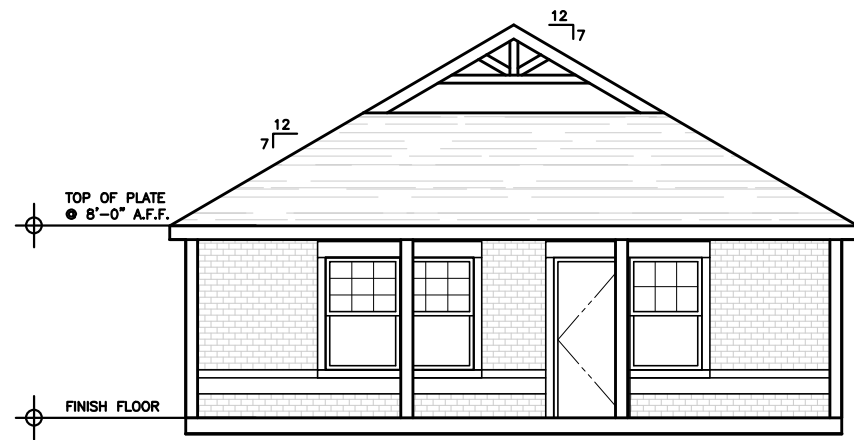

FRONT ELEVATION

SCALE: 1/8"=1'-0"

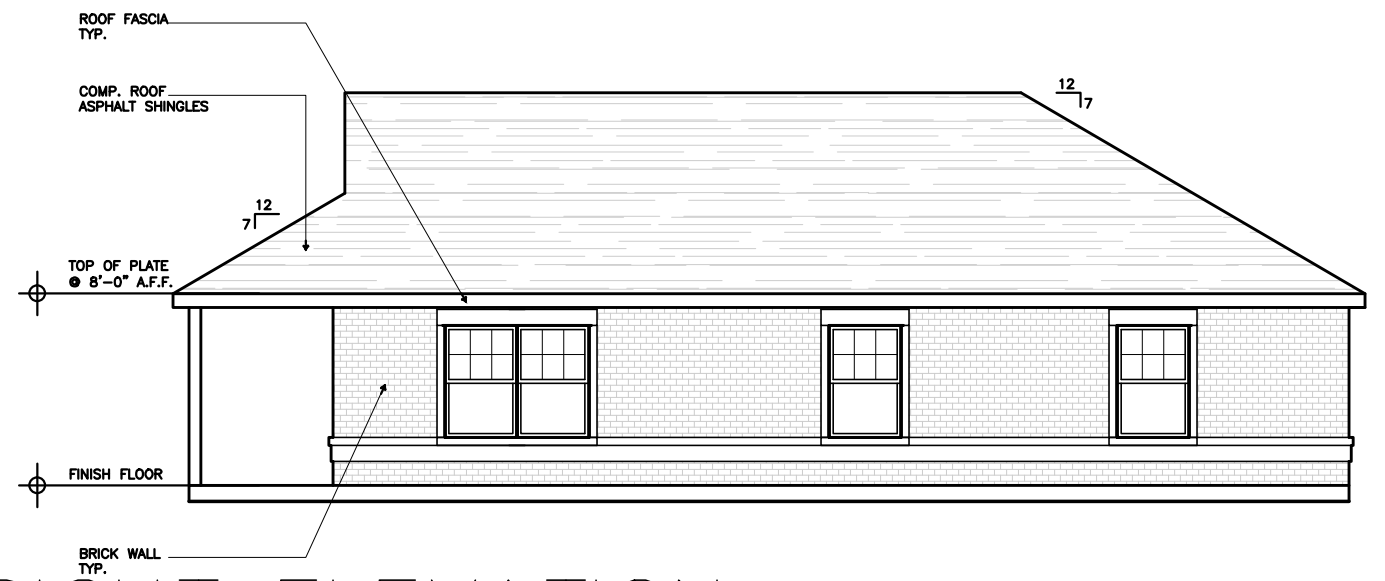

RIGHT ELEVATION

SCALE: 1/8"=1'-0"

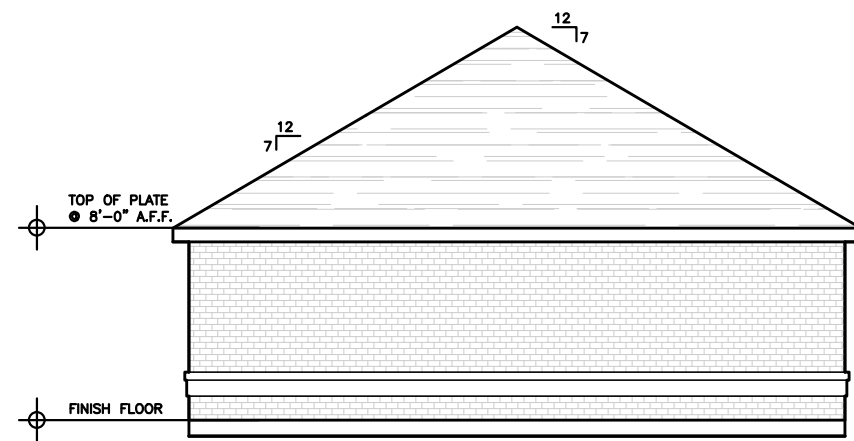

REAR ELEVATION

SCALE: 1/8"=1'-0"

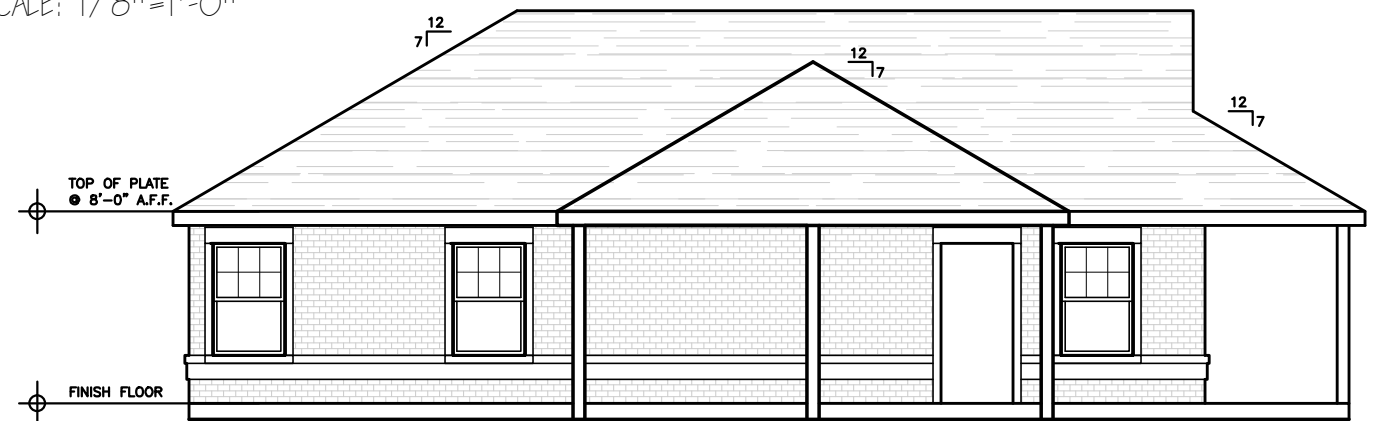

LEFT ELEVATION

SCALE: 1/8"=1'-0"

MODEL # 1R3

©LUBULA KANYINDA COPYRIGHTS 2017

PROJECT TITLE:

HOUSING PROJECT

STREET # ADDRESS
BRYAN, TEXAS

KANYINDA LLC

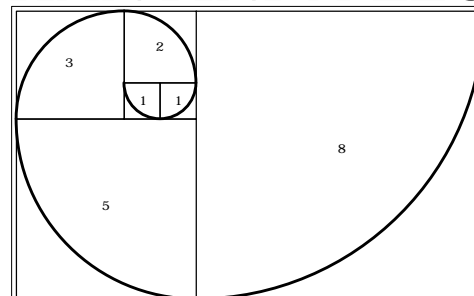

RESIDENTIAL & LAND DEVELOPMENT CONSULTANCY

7420 FRONT LAKE TRAIL
ARLINGTON, TEXAS 76002
PH: 682.551.6960

EMAIL: dixon.kanyinda@live.com

DRAWN BY:

PROJ DESIGNER:

PROJ COORD.:

SHEET#:

3

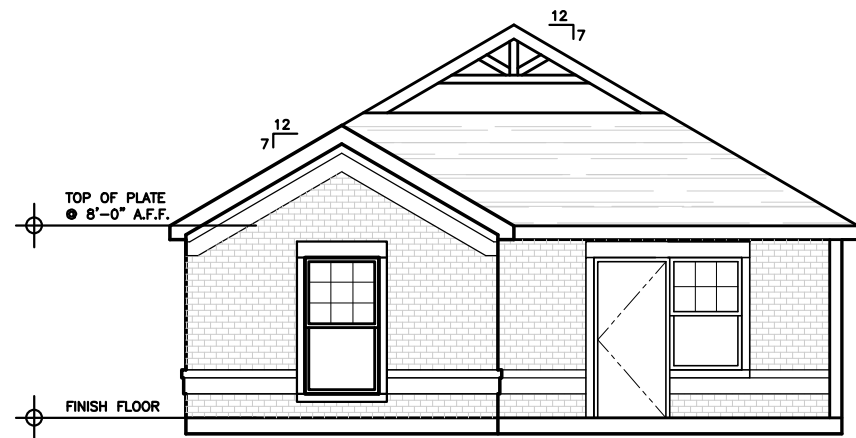

HOUSE DATA:

AIR CONDITIONED SPACE:	1,140 SQ. FT.
FRONT PORCH:	94 SQ. FT.
CAR PORT:	240 SQ. FT.
TOTAL GROSS SQ. FT.:	1,474 SQ. FT.

FRONT ELEVATION

SCALE: 1/8"=1'-0"

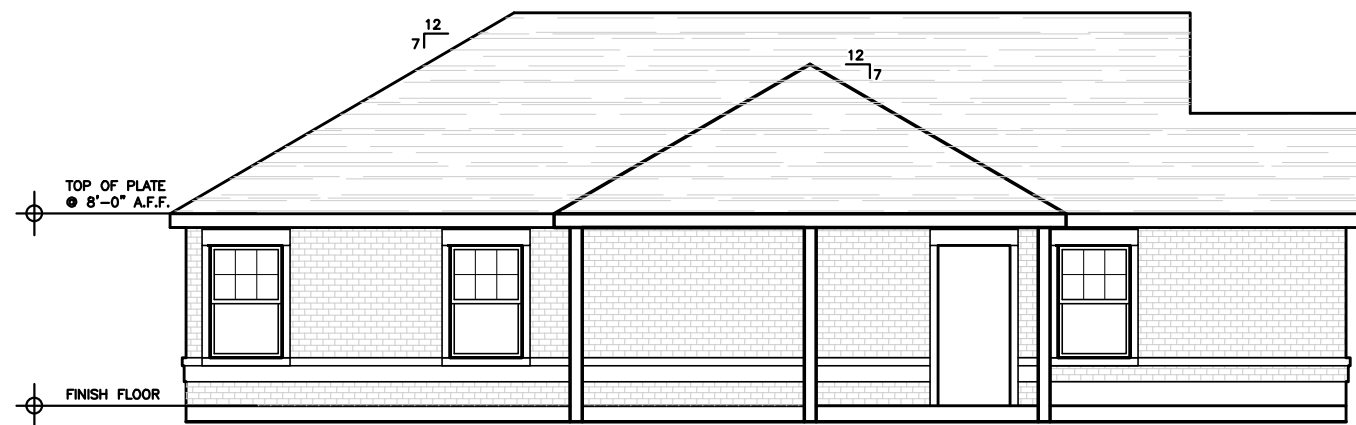

SIDE ELEVATION (SIM.)

SCALE: 1/8"=1'-0"

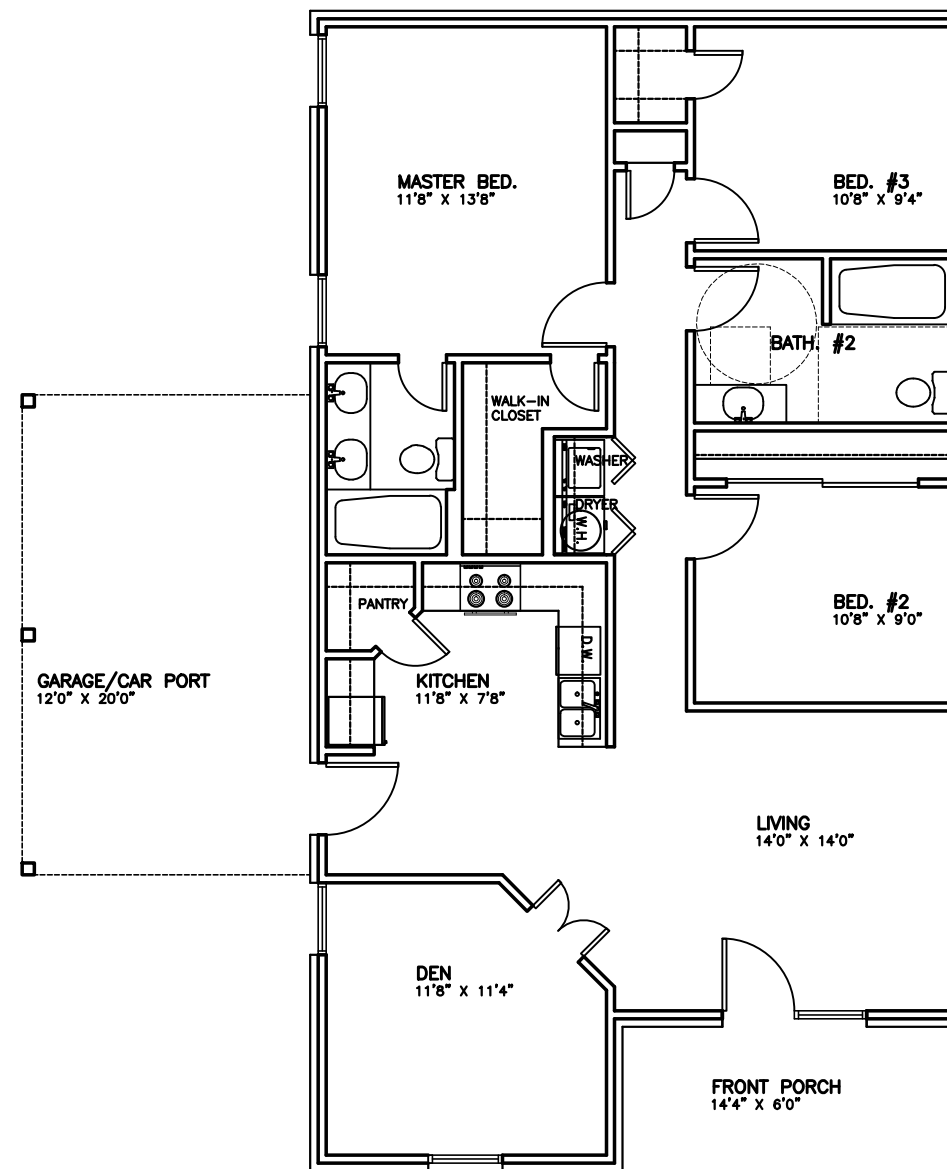

FLOOR PLAN

SCALE: 1/8"=1'-0"

MODEL # 1R4

©LUBULA KANYINDA COPYRIGHTS 2017

PROJECT TITLE:

HOUSING PROJECT

STREET # ADDRESS
BRYAN, TEXAS

KANYINDA LLC

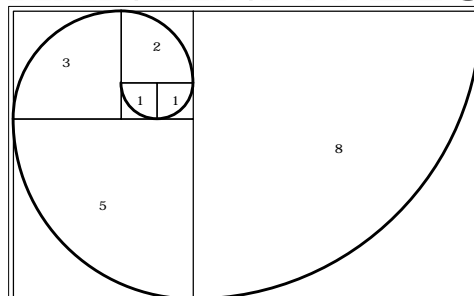

RESIDENTIAL & LAND DEVELOPMENT CONSULTANCY

7420 FRONT LAKE TRAIL
ARLINGTON, TEXAS 76002
PH: 682.551.6960

EMAIL: dixon.kanyinda@live.com

DRAWN BY:

PROJ DESIGNER:

PROJ COORD.:

SHEET#:

4

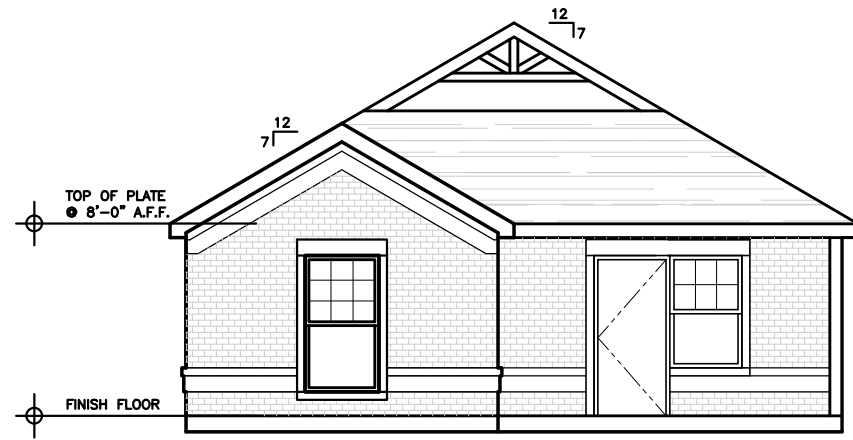

FRONT ELEVATION

SCALE: 1/8"=1'-0"

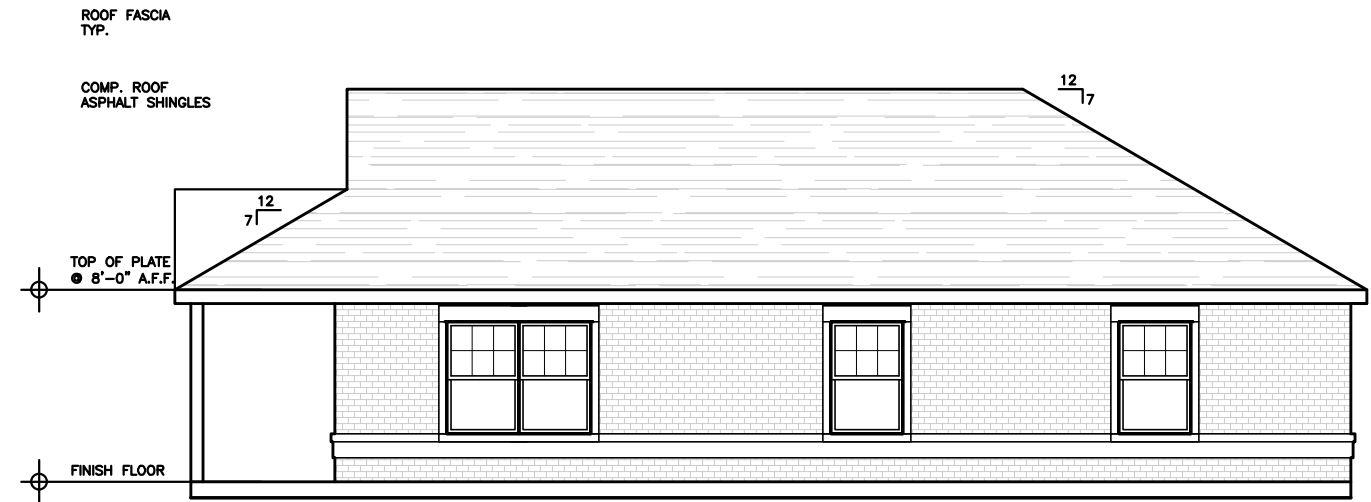

RIGHT ELEVATION

SCALE: 1/8"=1'-0"

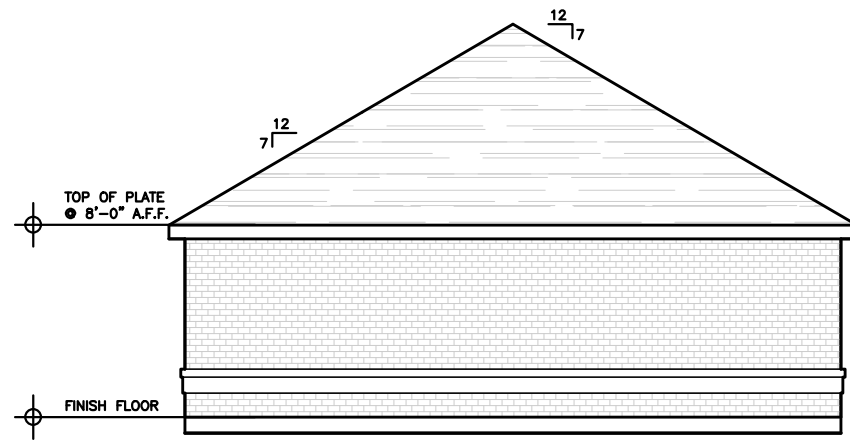

REAR ELEVATION

SCALE: 1/8"=1'-0"

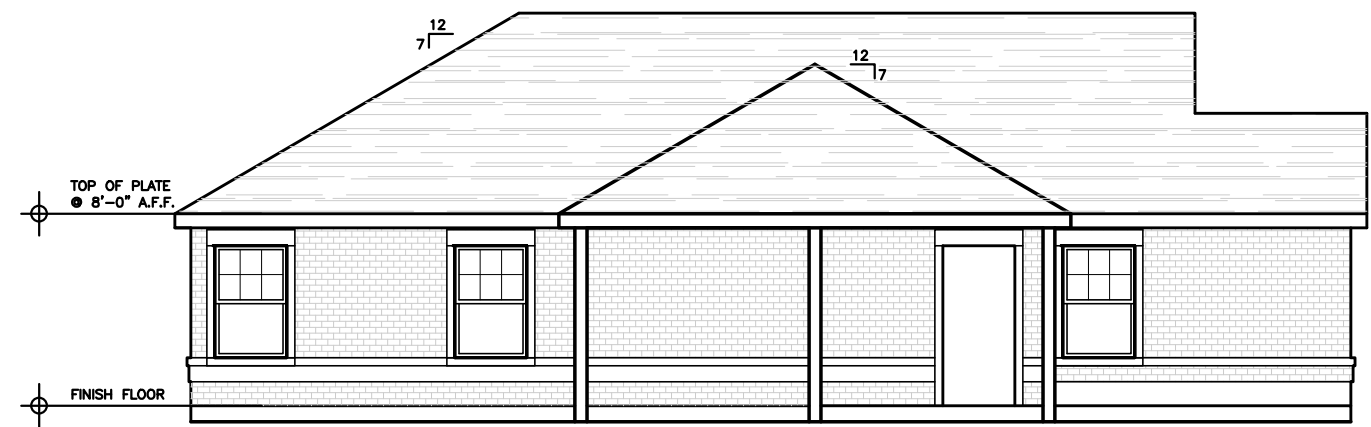

LEFT ELEVATION MODEL # 1R4

SCALE: 1/8"=1'-0"

©LUBULA KANYINDA COPYRIGHTS 2017

PROJECT TITLE:

HOUSING PROJECT

STREET # ADDRESS
BRYAN, TEXAS

KANYINDA LLC

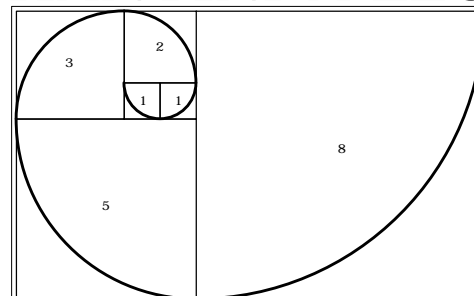

RESIDENTIAL & LAND DEVELOPMENT CONSULTANCY

7420 FRONT LAKE TRAIL
ARLINGTON, TEXAS 76002
PH: 682.551.6960

EMAIL: dixon.kanyinda@live.com

DRAWN BY:

PROJ DESIGNER:

PROJ COORD.:

SHEET#:

5



TAB 23

Specifications and Building/Unit Configuration



**TEXAS DEPARTMENT OF
HOUSING & COMMUNITY AFFAIRS**
Building Homes. Strengthening Communities.

TAB 24

Rent Schedule

Rent Schedule (Continued)

		% of LI	% of Total	
HOUSING TAX CREDITS	TC30%			0
	TC40%			0
	TC50%			0
	TC60%			0
	HTC LI Total			0
	EO			0
	MR			0
	MR Total			0
Total Units				0
MORTGAGE REVENUE BOND	MRB30%			0
	MRB40%			0
	MRB50%			0
	MRB60%			0
	MRB LI Total			0
	MRBMR			0
	MRBMR Total			0
	MRB Total			0

BEDROOMS	0			0
	1			0
	2			0
	3			29
	4			0
	5			0

		% of LI	% of Total	
NATIONAL HOUSING TRUST FUND	HTF30%			0
	HTF40%			0
	HTF50%			0
	HTF60%			0
	HTF80%			0
	HTF LI Total			0
	MR			0
	MR Total			0
HTF Total				0
DIRECT LOAN	30%	45%	45%	13
	LH/50%			0
	HH/60%			0
	HH/80%	55%	55%	16
	Direct Loan LI Total			29
	EO			0
	MR			0
	MR Total			0
Direct Loan Total				29
OTHER	Total OT Units			0

ACQUISITION + HARD		DO NOT USE THIS CALCULATION TO SCORE POINTS UNDER 11.9(e)(2). At the end of the Development Cost Schedule, you will have the ability to adjust your eligible costs to qualify. Points will be entered there.
Cost Per Sq Ft	\$ 88.43	
HARD		DO NOT USE THIS CALCULATION TO SCORE POINTS UNDER 11.9(e)(2). At the end of the Development Cost Schedule, you will have the ability to adjust your eligible costs to qualify. Points will be entered there.
Cost Per Sq Ft	\$ 88.43	
BUILDING		DO NOT USE THIS CALCULATION TO SCORE POINTS UNDER 11.9(e)(2). At the end of the Development Cost Schedule, you will have the ability to adjust your eligible costs to qualify. Points will be entered there.
Cost Per Sq Ft	\$ 55.88	



**TEXAS DEPARTMENT OF
HOUSING & COMMUNITY AFFAIRS**
Building Homes. Strengthening Communities.

TAB 25

Utility Allowances

Utility Allowances [§10.614]

Applicant must attach to this form as documentation to support the "Utility Allowance" estimate used in completing the Rent Schedule provided in the Application. Where the Applicant uses any method that requires Department review, such review must have been requested prior to submission of the Application. Please see 10 TAC §10.614. This exhibit must clearly indicate which utility costs are included in the estimate.

If tenants will be required to pay any other mandatory fees (e.g. renter's insurance) please provide an estimate, description and documentation of those as well.

Utility	Who Pays	Energy Source	0BR	1BR	2BR	3BR	4BR	Source of Utility Allowance & Effective Date
Heating	Tenant	Electric				\$ 34		Brazos Valley Council of Governments
Cooking	Tenant	Electric				\$ 9		Brazos Valley Council of Governments
Other Electric	Tenant					\$ 46		Brazos Valley Council of Governments
Air Conditioning	Tenant	Electric				\$ 39		Brazos Valley Council of Governments
Water Heater	Tenant	Electric				\$ 24		Brazos Valley Council of Governments
Water	Tenant					\$ 67		Brazos Valley Council of Governments
Sewer	Tenant					\$ 39		Brazos Valley Council of Governments
Trash	Tenant					\$ 15		Brazos Valley Council of Governments
Flat Fee								
Other								
Total Paid by Tenant			\$ -	\$ -	\$ -	\$ 273	\$ -	



Other (Describe)

If a revised form is submitted, date of submission:

U.S. Department of Housing
and Urban Development
Office of Public and Indian Housing

OMB Approval No. 2577-0169

**Allowances for Tenant
Furnished Utilities and other
Services**

Locality: Brazos Valley Council of Governments		Unit Type: Single Family House				Effective Date: 6/1/17	
Utility or Service - BRAZOS COUNTY		Monthly Dollar Allowances					
		0 BR	1 BR	2 BR	3 BR	4 BR	5 BR
Heating	a. Natural Gas	\$32	\$34	\$36	\$37	\$38	\$40
	b. Bottle Gas	\$41	\$49	\$53	\$58	\$62	\$66
	c. Electric	\$28	\$30	\$32	\$34	\$36	\$38
	d. Oil / Other						
Cooking	a. Natural Gas	\$2	\$3	\$4	\$5	\$6	\$7
	b. Bottle Gas	\$7	\$9	\$12	\$15	\$19	\$23
	c. Electric	\$4	\$5	\$7	\$9	\$11	\$13
	d. Coal / Other						
Other Electric		\$22	\$26	\$36	\$46	\$56	\$66
Air Conditioning		\$9	\$11	\$25	\$39	\$52	\$66
Water Heating	a. Natural Gas	\$6	\$7	\$10	\$13	\$16	\$19
	b. Bottle Gas	\$18	\$22	\$31	\$41	\$50	\$60
	c. Electric	\$11	\$13	\$17	\$21	\$24	\$28
	d. Oil / Other						
Water Service Only (not water well)		\$31	\$33	\$46	\$67	\$89	\$111
Sewer Service Only (not septic tank)		\$28	\$30	\$39	\$39	\$39	\$39
Trash Collection		\$15	\$15	\$15	\$15	\$15	\$15
Range / Microwave		\$10	\$10	\$10	\$10	\$10	\$10
Refrigerator		\$12	\$12	\$12	\$12	\$12	\$12
Other							
Actual Family Allowances					Utility or Service		per month cost
To be used by the family to compute allowance. <i>Complete below for the actual unit rented.</i>					Heating		\$
					Cooking		\$
Name of Family					Other Electric		\$
					Air Conditioning		\$
					Water Heating		\$
Address of Unit					Water		\$
					Sewer		\$
					Trash Collection		\$
City, State, Zip Code					Range / Microwave		\$
					Refrigerator		\$
					Natural Gas Flat Fee		\$
Number of Bedrooms							
					Total		\$



**TEXAS DEPARTMENT OF
HOUSING & COMMUNITY AFFAIRS**
Building Homes. Strengthening Communities.

TAB 26

Annual Operating Expenses

ANNUAL OPERATING EXPENSES

General & Administrative Expenses				
Accounting	\$	1,000		
Advertising	\$			
Legal fees	\$	1,500		
Leased equipment	\$			
Postage & office supplies	\$			
Telephone	\$			
Other	\$	<i>describe</i>		
Other	\$	<i>describe</i>		
Total General & Administrative Expenses:				\$ 2,500
Management Fee:	Percent of Effective Gross Income:	2.70%		\$ 6,906
Payroll Payroll Tax & Employee Benefits				
Management	\$			
Maintenance	\$			
Other	\$	<i>describe</i>		
Other	\$	<i>describe</i>		
Total Payroll, Payroll Tax & Employee Benefits:				\$ -
Repairs & Maintenance				
Elevator	\$			
Exterminating	\$			
Grounds	\$	12,000		
Make-ready	\$	1,000		
Repairs	\$			
Pool	\$			
Other	\$	<i>describe</i>		
Other	\$	<i>describe</i>		
Total Repairs & Maintenance:				\$ 13,000
Utilities (Enter Only Property Paid Expense)				
Electric	\$	<i>SOURCE USED FOR ESTIMATE</i>	15,000	
Natural gas	\$			
Trash	\$	<i>SOURCE USED FOR ESTIMATE</i>	3,000	
Water/Sewer	\$	<i>SOURCE USED FOR ESTIMATE</i>	5,000	
Other	\$	<i>describe</i>		
Other	\$	<i>describe</i>		
Total Utilities:				\$ 23,000
Annual Property Insurance:	Rate per net rentable square foot:	\$	0.00	
Property Taxes:				
Published Capitalization Rate:		Source:		
Annual Property Taxes	\$			
Payments in Lieu of Taxes	\$			
Total Property Taxes:				\$ -
Reserve for Replacements:	Annual reserves per unit:	\$	\$ 300	\$ 9,000
Other Expenses				
Cable TV	\$	2,000		
Supportive Services (Staffing/Contracted Services)	\$	30,000		
TDHCA Compliance fees	\$			
TDHCA Bond Administration Fees (TDHCA as Bond Issuer <u>Only</u>)	\$			
Security	\$			
Other	\$	<i>FICA</i>		
Other	\$	<i>describe</i>		
Total Other Expenses:				\$ 32,000
TOTAL ANNUAL EXPENSES	Expense per unit:	\$	2880	\$ 86,406
	Expense to Income Ratio:		33.74%	
NET OPERATING INCOME (before debt service)				\$ 169,682
Annual Debt Service				
<i>Rockhall Funding</i>	\$	130,000		
<i>TDHCA</i>	\$			
	\$			
	\$			
TOTAL ANNUAL DEBT SERVICE	Debt Coverage Ratio:		1.31	\$ 130,000
NET CASH FLOW				\$ 39,682

If a revised form is submitted, date of submission:



**TEXAS DEPARTMENT OF
HOUSING & COMMUNITY AFFAIRS**
Building Homes. Strengthening Communities.

TAB 27

**15 Year
Pro Forma**

15 Year Rental Housing Operating Pro Forma (All Programs)

The pro forma should be based on the operating income and expense information for the base year (first year of stabilized occupancy using today's best estimates of market rents, restricted rents, rental income and expenses), and principal and interest debt service. The Department uses an annual growth rate of 2% for income and 3% for expenses. Written explanation for any deviations from these growth rates or for assumptions other than straight-line growth made during the proforma period should be attached to this exhibit.

INCOME	YEAR 1	YEAR 2	YEAR 3	YEAR 4	YEAR 5	YEAR 10	YEAR 15
POTENTIAL GROSS ANNUAL RENTAL INCOME	\$256,692	\$261,826	\$267,062	\$272,404	\$277,852	\$306,771	\$338,700
Secondary Income	\$ 20,160	\$ 20,563	\$ 20,974	\$ 21,394	\$ 21,822	\$ 24,093	\$ 26,601
POTENTIAL GROSS ANNUAL INCOME	\$276,852	\$282,389	\$288,037	\$293,798	\$299,674	\$330,864	\$365,300
Provision for Vacancy & Collection Loss	(\$20,764)	(\$21,179)	(\$21,603)	(\$22,035)	(\$22,476)	(\$24,815)	(\$27,398)
Rental Concessions	\$0						
EFFECTIVE GROSS ANNUAL INCOME	\$256,088	\$261,210	\$266,434	\$271,763	\$277,198	\$306,049	\$337,903
EXPENSES							
General & Administrative Expenses	\$2,500	\$2,575	\$2,652	\$2,732	\$2,814	\$3,262	\$3,781
Management Fee	\$ 6,906	\$ 7,044	\$ 7,185	\$ 7,329	\$ 7,475	\$ 8,253	\$ 9,112
Payroll, Payroll Tax & Employee Benefits	\$ -	\$ -	\$ -	\$ -	\$ -	\$ -	\$ -
Repairs & Maintenance	\$ 13,000	\$ 13,390	\$ 13,792	\$ 14,205	\$ 14,632	\$ 16,962	\$ 19,664
Electric & Gas Utilities	\$ 15,000	\$ 15,450	\$ 15,914	\$ 16,391	\$ 16,883	\$ 19,572	\$ 22,689
Water, Sewer & Trash Utilities	\$ 8,000	\$ 8,240	\$ 8,487	\$ 8,742	\$ 9,004	\$ 10,438	\$ 12,101
Annual Property Insurance Premiums	\$ -	\$ -	\$ -	\$ -	\$ -	\$ -	\$ -
Property Tax	\$ -	\$ -	\$ -	\$ -	\$ -	\$ -	\$ -
Reserve for Replacements	\$ 9,000	\$ 9,270	\$ 9,548	\$ 9,835	\$ 10,130	\$ 11,743	\$ 13,613
Other Expenses	\$ 32,000	\$ 32,960	\$ 33,949	\$ 34,967	\$ 36,016	\$ 41,753	\$ 48,403
TOTAL ANNUAL EXPENSES	\$86,406	\$88,929	\$91,527	\$94,200	\$96,953	\$111,983	\$129,363
NET OPERATING INCOME	\$169,682	\$172,281	\$174,908	\$177,562	\$180,245	\$194,066	\$208,540
DEBT SERVICE							
First Deed of Trust Annual Loan Payment	\$130,000	\$130,000	\$130,000	\$130,000	\$130,000	\$130,000	\$130,000
Second Deed of Trust Annual Loan Payment							
Third Deed of Trust Annual Loan Payment							
Other Annual Required Payment							
Other Annual Required Payment							
ANNUAL NET CASH FLOW	\$39,682	\$42,281	\$44,908	\$47,562	\$50,245	\$64,066	\$78,540
CUMULATIVE NET CASH FLOW	\$39,682	\$81,963	\$126,870	\$174,433	\$224,677	\$510,455	\$866,969
Debt Coverage Ratio	1.31	1.33	1.35	1.37	1.39	1.49	1.60
Other (Describe)							
Other (Describe)							

By signing below I (we) are certifying that the above 15 Year pro forma, is consistent with the unit rental rate assumptions, total operating expenses, net operating income, and debt service coverage based on the bank's current underwriting parameters and consistent with the loan terms indicated in the term sheet and preliminarily considered feasible pending further diligence review. The debt service for each year maintains no less than a 1.15 debt coverage ratio. (Signature only required if using this pro forma for points under §11.9(e)(1) relating to Financial Feasibility)

Signature, Authorized Representative, Construction or Permanent Lender

Frank J. Mahan

Printed Name
02/27/2018

Date

Phone: 469-730-9159
Email: franker@aptfinanceusa.com

Signature, Authorized Representative, Syndicator

Printed Name

Date

If a revised form is submitted, date of submission: _____



**TEXAS DEPARTMENT OF
HOUSING & COMMUNITY AFFAIRS**
Building Homes. Strengthening Communities.

TAB 28

Offsite Costs Breakdown



**TEXAS DEPARTMENT OF
HOUSING & COMMUNITY AFFAIRS**
Building Homes. Strengthening Communities.

TAB 29

Site Work Costs Breakdown

Site Work Cost Breakdown

This form must be submitted with the Development Cost Schedule as justification of Site Work costs.

Column A: The Site Work activity reflected here must match the Site Work activity reflected in the Development Cost Schedule.

Columns B and C: In determining actual construction cost, two different methods may be used:

The construction costs may be broken into labor (Column B) and materials (Column C) for the activity; **OR**

The use of unit price (Column B) and the number of units (Column C) data for the activity.

Column D: To arrive at total construction costs in Column D:

If based on labor and materials, add Column B and Column C together to arrive at total construction costs.

If based on unit price measures, Column B is multiplied by Column C to arrive at total construction costs.

Column E: Any proposed activity involving the acquisition of real property, easements, rights-of-way, etc., must have the projected costs of this acquisition for the activity.

Column F: Engineering/architectural costs must be broken out by the Site Work activity.

Column G: Figures for Column G, Total Activity Cost, are obtained by adding together Columns D, E, and F to get the total costs.



Bijay Aryal

****This form must be completed by a Third-Party engineer licensed to practice in the State of Texas. His or her signature and registration seal must be on the form.****

For Site Work costs that exceed \$15,000 per Unit and are included in Eligible Basis, a CPA letter allocating which portions of those site costs should be included in Eligible Basis and which ones may be ineligible must be submitted behind this tab.

A. Activity	B. Labor or Unit Price	C. Materials or # of Units	D. Total Construction Costs	E. Acquisition Costs	F. Engineering / Architectural Costs	G. Total Activity Costs
Rough grading	lump sum		\$ 89,000.00			\$ 89,000
On-site concrete	lump sum		\$ 90,000.00			\$ 90,000
On-site utilities	lump sum		\$ 90,000.00			\$ 90,000
Electrical			\$ 60,000.00			\$ 60,000
Total						\$ 329,000

Signature of Registered Engineer

Printed Name

Seal

Date

If a revised form is submitted, date of submission: _____



**TEXAS DEPARTMENT OF
HOUSING & COMMUNITY AFFAIRS**
Building Homes. Strengthening Communities.

TAB 30

Development Cost Schedule

Development Cost Schedule

Self Score Total: 12

This Development Cost Schedule must be consistent with the Summary Sources and Uses of Funds Statement. All Applications must complete the total development cost column and the Tax Payer Identification column. Only HTC applications must complete the Eligible Basis columns and the Requested Credit calculation below:

TOTAL DEVELOPMENT SUMMARY		
Total Cost	Eligible Basis (If Applicable)	
	Acquisition	New/Rehab.

Scratch Paper/Notes

ACQUISITION

Site acquisition cost	0		
Existing building acquisition cost			
Closing costs & acq. legal fees			
Other (specify) - see footnote 1			
Other (specify) - see footnote 1			
Subtotal Acquisition Cost	\$0	\$0	\$0

OFF-SITES²

Off-site concrete			
Storm drains & devices			
Water & fire hydrants			
Off-site utilities			
Sewer lateral(s)			
Off-site paving			
Off-site electrical			
Other (specify) - see footnote 1			
Other (specify) - see footnote 1			
Subtotal Off-Sites Cost	\$0	\$0	\$0

SITE WORK³

Demolition			
Asbestos Abatement (Demolition Only)			
Detention			
Rough grading	89,000		89,000
Fine grading			
On-site concrete	90,000		90,000
On-site electrical	60,000		60,000
On-site paving			
On-site utilities	90,000		90,000
Decorative masonry			
Bumper stops, striping & signs			
Other (specify) - see footnote 1			
Subtotal Site Work Cost	\$329,000	\$0	\$329,000

SITE AMENITIES

Landscaping	60,000		60,000
Pool and decking	30,000		30,000
Athletic court(s), playground(s)			
Fencing	90,000		90,000
Other (specify) - see footnote 1			
Subtotal Site Amenities Cost	\$180,000	\$0	\$180,000

OTHER FINANCING COSTS³

Tax credit fees			
Tax and/or bond counsel			
Payment bonds			
Performance bonds			
Credit enhancement fees			
Mortgage insurance premiums	30,000		30,000
Cost of underwriting & issuance			
Syndication organizational cost			
Tax opinion			
Other (specify) - see footnote 1			
Other (specify) - see footnote 1			
Subtotal Financing Cost	\$299,140	\$0	\$259,140

DEVELOPER FEES³

Housing consultant fees ⁴	50,000		50,000
General & administrative	125,000		125,000
Profit or fee	340,000		340,000
Subtotal Developer Fees 15.49%	\$515,000	\$0	\$515,000 15.49%

Vanguard Consultants 100%
Noah Arc 50,000 AAOCC 75,000
NLIEDC 60% AAOCC 40 %

RESERVES

Rent-up	58,320		
Operating	85,048		
Replacement	20,000		
Escrows			
Subtotal Reserves	\$163,368	\$0	\$0

TOTAL HOUSING DEVELOPMENT COSTS⁵

	\$4,067,303	\$0	\$3,838,935
--	--------------------	------------	--------------------

The following calculations are for HTC Applications only.

Deduct From Basis:

Federal grants used to finance costs in Eligible Basis			
Non-qualified non-recourse financing			
Non-qualified portion of higher quality units §42(d)(5)			
Historic Credits (residential portion only)			
Total Eligible Basis		\$0	\$3,838,935
**High Cost Area Adjustment (100% or 130%)			125%
Total Adjusted Basis		\$0	\$4,798,669
Applicable Fraction			4%
Total Qualified Basis	\$191,947	\$0	\$191,947
Applicable Percentage ⁶			100.00%
Credits Supported by Eligible Basis (May be greater than actual request)	\$191,947	\$0	\$191,947

*11.9(c)(2) Cost Per Square Foot: DO NOT ROUND! Applicants are advised to ensure that figure is not rounding down to the maximum dollar figure to support the elected points.

Requested Score for 11.9(e)(2)

12

Name of contact for Cost Estimate: Rick Sims

Phone Number for Contact: (318) 349-1588

If a revised form is submitted, date of submission: _____



**TEXAS DEPARTMENT OF
HOUSING & COMMUNITY AFFAIRS**
Building Homes. Strengthening Communities.

TAB 31

Financing Narrative and Summary of Sources and Uses

Financing Narrative and Summary of Sources and Uses

Describe all sources of funds. Information must be consistent with the information provided throughout the Application (i.e. Financing Narrative, Term Sheets and Development Cost Schedule).

Financing Participants	Funding Description	Construction Period		Lien Position	Permanent Period					Lien Position
		Loan/Equity Amount	Interest Rate (%)		Loan/Equity Amount	Interest Rate (%)	Amort - ization	Term (Yrs)	Syndication Rate	
Debt										
TDHCA	MF Direct Loan Const. to Perm. (Repayable)	\$0	4.00%		\$ -	4.00%	30	40		1
TDHCA	MF Direct Loan Const. Only (Repayable)	\$0	2.00%							
TDHCA	Multifamily Direct Loan (Soft Repayable)	\$0	0.00%		\$ -	0.00%		40		
TDHCA	Mortgage Revenue Bond	\$0	0.00%		\$ -	0.00%	0	0		
	Private Loan									1
Third Party Equity										
	HTC	\$ -								
Housing Assistance Council		\$ 2,500,000		1	\$ 1,250,000	4.75%	5	30		1
Grant										
TDHCA HTF				2	\$ 2,000,000	0.00%	0	40		2
Deferred Developer Fee										
NLIEDC										
Other										
	Direct Loan Match									
Builder Profit and Overhead					\$ 185,619					
Contingency					\$ 32,663					
Total Sources of Funds		\$ 2,500,000			\$ 3,468,282					
Total Uses of Funds					\$ 3,468,282					

INSTRUCTIONS: Describe the sources of funds that will finance Development. The description must include construction, permanent, and bridge loans, and all other types of funds to be used for development. The information must be consistent with all other documentation in this section. Provide sufficient detail to identify the source and explain the use (in terms of the timing and any specific uses) of each type of funds to be contributed. In addition, describe/explain replacement reserves. Finally, describe/explain operating items. The narrative must include rents, operating subsidies, project based assistance, and all other sources of funds for operations. In the foregoing discussion of both development and operating funds, specify the status (dates and deadlines) for applications, approvals and closings, etc., associated with the commitments.

Describe the sources and uses of funds (specify the status (dates and deadlines) for applications, approvals and closings, etc., associated with the commitments). For Direct Loan or Tax-Exempt Bond Applications that contemplate an FHA-insured loan, this includes the anticipated date that FHA application will be submitted to HUD (if not already submitted).

The total development cost are \$3,468,282 The Const/Perm: Housing Assistance Council have committed to provide financing in the form of a CDFI Equity Loan in the amount of \$2,500,000./\$1,250,000 The term and rates are 5/30 at 4.75 percent. The applicant is applying for CHDO certification and is requesting \$2,000,000 in /NHTF Funds . As a construction loan takeout commitment The remainder of the financing will consist of shared risk from the non profit developer and builder in the amount of \$218,282 The applicant is applying for CHDO Certification with the certification the Texas Government Code 11.182 provides 100% tax abatement for CHDO that have cash flow are for Supportive Services for persons with disabilities, the property taxes for Bryan is 1% of the assessed value equals 40,000 per years the owners AAOCC equity based upon present T-Bill is \$ 962,032.43 @ 30 yrs

Describe the replacement reserves:

The will be an annual replacement of \$300.00 per units per year for a total of \$9000.00.

Describe the operating items (rents, operating subsidies, project based assistance, etc., and specify the status (dates and deadlines) for applications, approvals and closings, etc., associated with the commitments:

Rents are deep targeted for the 30 percent ami, (13) of the 29 units. This is mainly units design is low maintenace and easliy convertible for any type of modification of the structure for the special needs population. Using the upkeep for this type of development his lawn work and annual power wash of the housing units

By signing below I acknowledge that the amounts and terms of all anticipated sources of funds as stated above are consistent with the assumptions of my institution as one of the providers of funds.

Signature, Authorized Representative, Construction or Permanent Lender

Printed Name

Date

Telephone: _____

Email address: _____

If a revised form is submitted, date of submission: _____

INSTRUCTIONS: Describe the sources of funds that will finance Development. The description must include construction, permanent, and bridge loans, and all other types of funds to be used for development. The information must be consistent with all other documentation in this section. Provide sufficient detail to identify the source and explain the use (in terms of the timing and any specific uses) of each type of funds to be contributed. In addition, describe/explain replacement reserves. Finally, describe/explain operating items. The narrative must include rents, operating subsidies, project based assistance, and all other sources of funds for operations. In the foregoing discussion of both development and operating funds, specify the status (dates and deadlines) for applications, approvals and closings, etc., associated with the commitments.

Describe the sources and uses of funds (specify the status (dates and deadlines) for applications, approvals and closings, etc., associated with the commitments). For Direct Loan or Tax-Exempt Bond Applications that contemplate an FHA-insured loan, this includes the anticipated date that FHA application will be submitted to HUD (if not already submitted).

The total development cost are \$4,067,303 The Const/Perm: Rock Hall Funding have committed to provide financing in the form of a USDA 538 Loan in the amount of 2.15 million. The term and rates are 40/40 at 4.00 percent. The applicant is applying for CHDO certification and is requesting \$1,000,000 in HOME/NHTF Funds . The remainder of the financing will consist of shared risk from the non profit developer and builder in the amount of \$467,303..00 The applicant is applying for CHDO Certification with the certification the Texas Government Code 11.182 provides 100% tax abatement for CHDO that have cash flow are for Supportive Services for persons with disabilities, the property taxes for Bryan is 1% of the assessed value equals 40,000 per years the owners AAOCC equity based upon present T-Bill is \$ 962,032.43 @ 30 yrs

Describe the replacement reserves:

The will be an annual replacement of \$300.00 per units per year for a total of \$9000.00.

Describe the operating items (rents, operating subsidies, project based assistance, etc., and specify the status (dates and deadlines) for applications, approvals and closings, etc., associated with the commitments:

Rents are deep targeted for the 30 percent ami, (13) of the 30 units. This is mainly units design is low maintenance and easliy convertible for any type of modification of the structure for the special needs population. Using the upkeep for this type of development his lawn work and annual power wash of the housing units

By signing below I acknowledge that the amounts and terms of all anticipated sources of funds as stated above are consistent with the assumptions of my institution as one of the providers of funds.

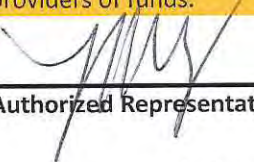

Signature, Authorized Representative, Construction or Permanent Lender

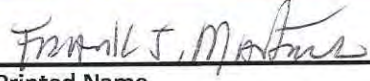

Printed Name



Date

Telephone: 469-730-4159
Email address: frankie@aptfinanceusa.com

If a revised form is submitted, date of submission: _____



TEXAS DEPARTMENT OF
HOUSING & COMMUNITY AFFAIRS
Building Homes. Strengthening Communities.

TAB 32

**HOME Applications Only
Financial Capacity
and
Construction Oversight**

Financial Capacity, Owner Equity, and Appraisal Requirements (Multifamily Direct Loan Applications Only, if applicable) [§13.8(c)(5) and (6)]

Financial Capacity (10 TAC §13.8(c)(5))

If the Department's Direct Loan amounts to more than 50% of the Total Housing Development Cost, except for Direct Loan Developments also financed through the USDA §515 program, the Application **MUST** include:

- A letter from a Third Party CPA verifying the capacity of the Applicant, Developer, or Development Owner to provide at least 10% of the Total Housing Development Cost as a short term loan for Development; **OR**
- Evidence of a line of credit or equivalent tool equal to at least 10% of the Total Housing Development Cost from a financial institution that is available for use during the proposed development activities.

Owner Equity and Appraisal Requirements (10 TAC §13.8(c)(6))

If the Direct Loan is the only source of Department funding for the Development (no HTC being requested), the Development Owner **MUST** provide:

- equity in an amount not less than 20% of Total Housing Development Costs; and
- if proposing new construction, an "as completed" appraisal pursuant to 10 TAC §10.304 which results in a repayable loan to value of not greater than 80%; or
- if proposing rehabilitation, the "as is" appraisal required by 10 TAC §10.205(4) may meet this requirement without needing an "as completed" appraisal provided the loan to value is not greater than 80%

As a result of providing owner equity in an amount greater than 5% of Total Housing Development Costs, the following must be provided in accordance with 10 TAC §10.204(7)(C):

- A letter - not older than 6 months from the date of Application submission - from a Third Party CPA verifying the capacity of the Development Owner to provide the proposed financing with funds that are not otherwise committed or pledged; and
- A letter - not older than 6 months from the date of Application submission - from the Development Owner's bank or banks confirming that such funds are and will remain available at commitment and until the required investment is completed.





TEXAS DEPARTMENT OF
HOUSING & COMMUNITY AFFAIRS
Building Homes. Strengthening Communities.

TAB 33

**HOME Applications Only
Matching Funds**

Match Funds (Multifamily Direct Loan Applications Only) [§10.204(7)(E)]

Match in the amount of at least 5% of the Multifamily Direct Loan funds requested must be documented with a letter from the anticipated provider of Match indicating the provider's willingness and ability to make a financial commitment should the Development receive an award of Multifamily Direct Loan funds. The information provided must be consistent with all other documentation in the Application.

Indicate the amount and source of Match funds in the appropriate spaces in the table below.

Generally, a Related Party contribution to the Development is not considered eligible Match. Please see 10 TAC §13.2(8) as well as the Match Guidance below.

Type of Match Pledged	Pledged Amount	Source of Funds
Non-Federal Grants		
Waived, foregone or deferred fees and charges (ex: debris removal and container fees, tap fees, building permits, other mandatory fees charged by the local municipality) **CANNOT INCLUDE DEVELOPER FEES**		
Below Market Interest Rate Loan		
Property Tax Abatement	\$ 125,000	Brazos County
Donated Non-Professional Labor		
Non-Federally Funded Infrastructure		
Rental Value of Donated Use of Site Preparation or Construction Equipment		
Donated Construction Materials		
Donated Site Preparation		
Donated Demolition Services		
Donated Real Property	\$ 2,000,000	Appraisal
Total Value of Match Pledged	\$ 2,125,000	
Total Amount of MF Direct Loan funds Requested	\$ 1,000,000	
Percentage of MF Direct Loan Funds to be Matched (Total Value of Match /MF Direct Loan Funds Requested)	212.50%	



[Home](#) > [Individual](#)

Growth Calculator Results

This calculator is for estimation purposes only.

Initial Investment Amount:	\$20,000.00
Expected Interest Rate:	3.00%
Periodic Investment:	\$10,000.00
How Often:	Annually
Years Invested:	30
Your Federal Tax Rate:	0%

GROWTH CALCULATOR RESULTS

By purchasing **U.S. Savings Bonds**, in **30 year(s)**, your investment could be worth (after federal taxes):
\$524,299.41

Tax debitment

Education Savings:

If you use your Savings Bonds to pay for educational costs, your earnings may be tax free (provided you meet certain [qualifications](#)).

Your investment could be worth as much as:
\$524,299.41

matching contribution Bryan

Why Buy Bonds?

[Savings Bonds](#) make it easy and affordable to begin investing in your future goals.

[Back to Growth Calculator](#)

Because interest and tax rates can't be predicted, these calculators are only intended to give you an idea of what your investment could be worth based on the assumptions you make. Actual earnings may be different.

Instructions

[How to Use the Growth Calculator](#)

Purchase Limits

[Savings Bonds Purchase Limits](#)

[Freedom of Information Act](#) | [Law & Guidance](#) | [Privacy & Legal Notices](#) | [Website Terms & Conditions](#) | [Web API Documentation](#) | [Plug-ins & Viewers](#) | [Accessibility](#) | [Data Quality](#)

U.S. Department of the Treasury, Bureau of the Fiscal Service

Harris County Appraisal District

Check List for Organization Exemptions

The items listed below are the basic items needed to process most applications for total exemption for groups or organizations.

- Attach complete copies of the organization's articles of incorporation and bylaws. (Attach bylaws or other governing documents if the organization is not a corporation.)
- Attach a Schedule A (or Schedule AR), Description of Real Property, for each parcel requested to be exempt.
- Attach a Schedule B (or Schedule BR), Description of Personal Property, for all personal property requested to be exempt.
- Attach a copy of the warranty deed(s) that give the organization ownership of the property.
- If applying for a project that is under "active construction", attach documentation showing that site work, architectural work, soil studies, or other preparation has begun, along with a timetable for completion.
- If applying under Sec. 11.18 (Charitable Organization), the organization must perform at least one of the activities listed under Step 2, number 4. Be sure to check the appropriate box(es).

Please visit www.hcad.org, click Forms, and see Charitable, Non-profit, Schools & Miscellaneous forms to find the suitable application for your organization.

Please note: you must apply using the application form appropriate to your organization's primary function. If HCAD requires additional documentation you will be notified by mail. Please ensure that a correct mailing address is submitted on the application.

Harris County Appraisal District
 Exemption Center
 13013 Northwest Fwy.
 P. O. Box 922012
 Houston, TX. 77292-2012
 (713) 812-5830
11.1825 (08/04)



Application for Constructing or Rehabilitating Low-Income Housing Property Tax Exemption for _____

Final Exemption
 Preliminary Determination of Exemption

This application covers property you owned on January 1 of this year. You must file the completed form between January 1 and no later than April 30 of this year. If the chief appraiser grants the final exemption, you do not need to reapply annually, but you must reapply if the chief appraiser requires you to do so. You must notify the chief appraiser in writing if and when your right to this exemption ends. Be sure to attach any additional documents requested. Return the completed form to the address above.

*You are required to give us this information on this form, in order to perform tax related functions for this office. Section 11.43 of the Tax Code authorizes this office to request this information to determine tax compliance. The chief appraiser is required to keep the information confidential and not open to public inspection, except to appraisal office employees who appraise property and as authorized by Section 11.48(b), Tax Code.

Step 1: Name and Address of Organization

Name of Organization (please print) _____

Current Mailing Address _____

City, Town, Post Office, State, ZIP Code + 4 _____

Telephone (area code and number) _____

Name of person preparing this application _____

Driver's License, Personal ID Certificate, or
 Social Security Number *

Title _____

Step 2: Form of Organization

1. Type of Organization: a. Individual b. Foundation c. Corporation
 d. Trust e. Limited Partnership f. Entity of the Organization

Note: Entity of the organization is an entity whose parent organization is a charitable organization that meets the requirements of Tax Code Section 11.18(e) and (f).

2. If owner of the property is a "Limited Partnership," answer the following questions:

- a. Is the general partner controlled 100 percent by a charitable organization? a. Yes No
 1. If "Yes", complete Step 3 below concerning the charitable organization.
- b. Is the limited partnership organized under the laws of Texas? b. Yes No
- c. Is the limited partnership's principal place of business in Texas? c. Yes No

3. If owner of the property is an "Equity of the organization," answer the following questions:

- a. Is the entity organized under the laws of Texas? a. Yes No
- b. Is the entity's principal place of business in Texas? b. Yes No
- c. Complete Step 3 below concerning the parent organization.

Step 3: Answer the Following Questions About the Organization

4. For the preceding three years (note years) _____, answer these questions:

- a. Has the organization been exempt from federal income taxation under Section 501(a), Internal Revenue Code of 1986, as amended, as an exempt entity under Section 501(c)(3) of that Code? a. Yes No
- b. Has the organization operated, or its charter permit to operate, in a manner that permits the accrual of profits or distribution of any form of private gain? b. Yes No
 1. If "Yes", explain on a separate attached page.
- c. Has the organization used its assets in providing low-income housing? c. Yes No
- d. In the past year has the organization loaned funds to, borrowed funds from, sold property to or bought property from a shareholder, director or member of the organization, or has a shareholder or member sold his interest in the organization for a profit? d. Yes No

Step 3: Answer the Following Questions About the Organization (continued)

- 1. If "Yes," attach a description of each transaction. For sales, give buyer, seller, price paid, value of the property sold and date of sale. For loans give lender, borrower, amount borrowed, interest rate and term of loan. Attach a copy of note, if any.
- e. Attach a list of salaries and other compensation for services paid in the last year. List any funds distributed to members, shareholders or directors in the last year. In each case, give recipient's name, type of service rendered or reason for payment and amounts paid.

5. About the board of directors, answer these questions:

- a. Does a majority of the members of the organization's board of directors of the organization have their principal place of residence in Texas? a. Yes No

1. Attach a list of the board members and their principal places of residence.

- b. Do two or more directors on the board whose principal place of residence is located in Texas meet one of the following requirements: an individual of low income as defined by Section 2306.004, Government Code; or an individual whose residence is located in an economically disadvantaged census tract in Texas, as defined by Section 783.009(b), Government Code; or is a representative appointed by neighborhood organization in Texas that represents low-income households? b. Yes No

1. Note on attached list of board members those directors that meet one of these provisions, and indicate which provisions.

6. About policies, bylaws, or charter, answer these questions:

- a. Does the organization have a formal policy containing procedures for giving notice to and receiving advice from low-income households residing in the county in which a housing project is located regarding the design, siting, development and management of affordable housing projects? a. Yes No

1. If "Yes", attach a copy of the formal policy.

- b. Does the organization perform, or does its charter permit it to perform, any functions other than those of providing low-income housing? b. Yes No

1. If "Yes", attach a statement describing the other functions in detail.

- c. Do the by-laws or charter direct that on the discontinuance of the organization the organization's assets are to be transferred to the State of Texas, to the United States, or to an educational, religious, charitable or other similar organization that is qualified for exemption under Section 501(c)(3), Internal Revenue Code, as amended? c. Yes No

1. If "Yes", give the page and paragraph numbers. Page _____ Paragraph _____

- 2. If "No," do these documents direct that on discontinuance of the organization the organization's assets are to be transferred to members who have promised in their membership applications to immediately transfer them to the State of Texas, to the United States or to an educational, religious, charitable or other similar organization that is qualified for exemption under Section 501(c)(3), Internal Revenue Code, as amended? 2. Yes No

3. If "Yes", give the page and paragraph numbers. Page _____ Paragraph _____

- 4. If "Yes", was the two-step transfer required for the organization to qualify for exemption under Section 501(c)(12), Internal Revenue Code, as amended? 4. Yes No

Step 4: Audit

Property may not be exempt for a tax year unless the organization owning or controlling the owner of the property has an audit prepared by an independent auditor covering the organization's most recent fiscal year. The audit must include (1) an opinion on whether the organization's financial statements present fairly, in all material respects and in conformity with generally accepted accounting principles, the financial position, changes in net assets, and cash flows of the organization; and (2) that the organization has complied with all of the terms and conditions under Tax Code Section 11.1825. If the property contains less than 36 dwelling units, the organization may deliver a detailed report and certification as an alternative to an audit. Attach the audit or deliver within 180 days after the last day of the organization's most recent fiscal year.

Step 5: Describe the Property

Property To Be Exempt

- Attach Schedule A (Constructing) form for each parcel of land and each building of real property to be exempt for constructing low-income housing.
Attach Schedule B (Rehabilitating) form for each parcel of land and building to be exempt for rehabilitating low-income housing.
- If the organization receives this exemption and acquires additional improved or unimproved real property at any time during the year, the organization must file a Schedule A or Schedule B for that property not later than the 30th day after the date of acquisition. For that tax year, the exemption is applicable only to that portion of the year in which the property qualifies for exemption. Please indicate with the Schedule A or Schedule B that the organization currently qualifies for this exemption.

Step 6: Sign the Application

By signing this application you certify that the property described in the attached Schedules A and B as the property against which this exemption may be claimed in this appraisal district.

You certify that this information is true and correct to the best of your knowledge and belief.

On behalf of (name of organization)	Date
Authorized signature sign  here	Title

If you make a false statement on this form, you could be found guilty of a Class A misdemeanor or a state jail felony under Texas Penal Code Section 37.10.

Schedule A: Constructing Low-Income Housing

[11.1825, Rule 9.415]

Complete one Schedule A form for EACH land parcel of improved (with building) and unimproved real property qualified for exemption. Attach all completed schedules to your application for exemption.

Name of Owner (please print): _____

Property Address _____

City, Town, Post Office, State, ZIP code +4 _____

Legal Description of Property _____

Account Number _____

1. Describe the primary use of the property _____

2. Date of acquisition of property ____ / ____ / ____

3. Is this property reasonably necessary for operation of the organization? 3. Yes No

4. Answer these questions about the property listed above.

a. Is this property under "active construction" or "physical preparation?" a. Active Construction Physical Preparation

1. If "active construction," when will construction be completed? 1. ____ / ____ / ____

2. If "physical preparation," what has been done? _____

"Physical preparation" is when the organization has engaged in architectural or engineering work, soil testing, land clearing activities, or site improvement work necessary for constructing the project or has conducted an environmental or land use study for constructing the project.

5. Does the organization plan to rent or sell dwelling units in this building to individuals or families? 5. Rent Sell

6. Questions regarding renting dwelling units:

a. Do/will the individuals and families have a median income that is not more than 60 percent of either the area or statewide median family income? a. Yes No
(check one)

1. Area median family income for the household's place of residence, as adjusted for family size and as established by the United States Department of Housing and Urban Development, which is \$ _____.

OR

2. Statewide area median family income, as adjusted for family size and as established by the United States Department of Housing and Urban Development, which is \$ _____.

b. What is the annual total of the monthly rent charged or to be charged for each dwelling unit in this building that is reserved for an individual or family? b. \$ _____ /year

c. Will the organization be renting or offering to rent the applicable square footage of dwelling units in this building to qualified individuals and families by the third anniversary of the date the organization acquired this property? c. Yes No

9. Questions regarding selling dwelling units

a. Do/will the individuals and families have a median income that is below either the area or statewide median family income? a. Yes No
(check one)

1. Area median family income for the household's place of residence, as adjusted for family size and as established by the United States Department of Housing and Urban Development, which is \$ _____.

OR

2. Statewide area median family income, as adjusted for family size and as established by the United States Department of Housing and Urban Development, which is \$ _____.

b. How many dwelling units does/will the above describe property have? b. _____ units

c. What percentage of the total square footage of the dwelling units in this building described above are/will be reserved for individuals or families noted in question number 5 above? c. _____ %

Schedule B: Rehabilitating Buildings for Low-Income Housing

[11.1825, Rule 9.415]

Complete one Schedule B form for EACH building and land qualified for exemption. Attach all completed schedules to your application for exemption.

Name of Owner (please print): _____

Property Address _____

City, Town, Post Office, State, ZIP code +4 _____

Legal Description of Property	Account Number
-------------------------------	----------------

1. Describe the primary use of the property _____ 2. Date of acquisition of property ____ / ____ / ____

3. Is this property reasonably necessary for operation of the organization? 3. Yes No

4. Answer these questions about the property listed above

a. When did actual rehabilitation of this property begin? a. ____ / ____ / ____

b. When will rehabilitation of this property be completed? b. ____ / ____ / ____

c. When was the original construction of this housing project completed? c. ____ / ____ / ____

d. If the organization acquired this property from another person/organization, how long did the person/organization own the property? d. \$ _____ /year

e. Has the organization spent the greater of: (check one)

- 1. \$5,000 or
- 2. amount required by the financial lender for each dwelling unit in the project for the rehabilitation of this property?

f. Does the organization maintain a reserve fund for replacements? In what amount:

- 1. amount required by the financial lender for each dwelling unit in the project or
- 2. \$300 for each dwelling unit in the project or
- 3. _____ amount for each dwelling unit in the project adjusted for cost-of-living (for tax years 2005 or later)

g. Has the organization made withdrawals from the reserve? g. Yes No

1. if "Yes," was it: (check one)

- a. authorized by the financial lender or
- b. to pay the cost of capital improvements needed to maintain habitability under the Minimum Property Standards of the U. S. Department of Housing and Urban Development. "Capital improvement" is a property improvement that has a depreciable life of at least five years, excluding typical "make ready" expenses such as plaster repair, interior paint, or floor coverings.

h. Does the organization plan to rent or sell dwelling units in this building to individuals or families? h. Yes No

5. Questions regarding renting dwelling units:

a. Do/will the individuals and families have a median income that is not more than 60 percent of either the area or statewide median family income: (check one)

1. Area median family income for the household's place of residence, as adjusted for family size and as established by the United States Department of Housing and Urban Development, which is \$ _____.

OR

2. Statewide area median family income, as adjusted for family size and as established by the United States Department of Housing and Urban Development, which is \$ _____.

b. What is the annual total of the monthly rent charged or to be charged for each dwelling unit in this building that is reserved for an individual or family noted in question 4b above? b. \$ _____ /year

c. Will the organization be renting or offering to rent the applicable square footage of dwelling units in this building to qualified individuals and families by the third anniversary of the date the organization acquired this property? c. Yes No

6. Questions regarding selling dwelling units

a. Do/will the individuals and families have a median income that is below either the area or statewide median family income: (check one)

1. Area median family income for the household's place of residence, as adjusted for family size and as established by the United States Department of Housing and Urban Development, which is \$ _____.

OR

2. Statewide area median family income, as adjusted for family size and as established by the United States Department of Housing and Urban Development, which is \$ _____.

b. How many dwelling units does/will the above describe property have? b. _____ units

c. What percentage of the total square footage of the dwelling units in this building described above are/will be reserved for individuals or families noted in question number 4b above? c. _____ %

Harris County Appraisal District
 Exemption Center
 P. O. Box 922010
 Houston, TX. 77292-2010
 (713) 812-5830
11.181 (01/2012)



Application for Charitable Organizations Improving Property For Low-Income Housing Property Tax Exemption for _____ Year

This application covers property you owned on January 1 of this year. You must file the completed form between January 1 and no later than April 30 of this year. Please note, the Supplemental Application for Charitable Organizations Improving Property for Low-Income Housing covers improved and unimproved real property acquired at any time during the year, and must be filed not later than the 30th day after you acquire the property. Be sure to attach any additional documents requested. You must apply for this exemption every year; it will not be automatically renewed. **Once you have filled out the on-line form, you must print it, sign it, and return the form to the address above**

Step 1. Name and Address of Organization

Name of Organization		
Present Mailing Address (number and street)		
City, Town or Post Office, State, ZIP Code		Phone (area code and number)
Name of Person Preparing this Application	Driver's License, Personal I. D. Certificate, or Social Security Number*	Title

If this application is for an exemption from ad valorem taxation of property owned by a charitable organization with a federal tax identification number, that number may be provided here in lieu of a driver's license number, personal identification certificate number, or social security number:

* Unless the applicant is a charitable organization with a federal tax identification number, the applicant's driver's license number, personal identification certificate number, or social security account number is required. Pursuant to Tax Code Section 11.48(a), a driver's license number, personal identification certificate number, or social security account number provided in an application for an exemption filed with a chief appraiser is confidential and not open to public inspection. The information may not be disclosed to anyone other than an employee of the appraisal office who appraises property, except as authorized by Tax Code Section 11.48(b). If the applicant is a charitable organization with a federal tax identification number, the applicant may provide the organization's federal tax identification number in lieu of a driver's license number, personal identification certificate number, or social security account number.

Step 2. Form of Organization

1. Operator of Organization (check appropriate box) Individual Foundation Corporation Trust
2. If operated by a corporation, is the corporation non-profit as defined by the Texas Non-Profit Corporation Act (art.1396-1.01 VACS et seq.)? 2. YES NO

Step 3. Answer These Questions About the Organization

3. Does the organization own the property for the purpose of building or repairing housing on it primarily with the use of volunteer labor, and to sell without profit to an individual or family satisfying the organization's low-income and other eligibility requirements? 3. YES NO
4. Does the organization engage exclusively in the building, repair, and sale of housing as described above, and related activities? 4. YES NO
5. Does the organization perform or does its charter permit it to perform, any functions other than those checked in question 2? 5. YES NO
 - a. If "Yes," attach a statement describing the other functions in detail.
6. In the past year has the organization loaned funds to, borrowed funds from, sold property to or bought property from a shareholder, director or member of the organization, or has a shareholder or member sold his interest in the organization for a profit? 6. YES NO
 - a. If "Yes," attach a description of each transaction. For sales, give buyer, seller, price paid, value of the property sold and date of sale. For loans, give lender, borrower, amount borrowed, interest rate and term of loan. Attach a copy of note, if any.
7. Attach a list of salaries and other compensation for services paid in the last year. Also list any funds distributed to members, shareholders or directors in the last year. In each case, give recipient's name, type of service rendered or reason for payment and amounts paid.
8. Does the organization operate, or its charter permit it to operate, in a manner which permits the accrual of profits or distribution of any form of private gain? 8. YES NO
 - a. If "Yes," please explain on a separate attached page.

Step 4. Answer These Questions About the Organization Bylaws or Charter

9. Attach a copy of the charter, bylaws or other documents adopted by the organization which govern its affairs, and answer the following questions.
10. Do these documents pledge the organization's assets for use in performing the organization's charitable functions? 10. YES NO
- a. If "Yes," give the page and paragraph numbers. Page _____ Paragraph _____
11. Do these documents direct that on the discontinuance of the organization the organization's assets are to be transferred to the State of Texas or to an educational, religious, charitable or other similar organization that is qualified for exemption under Sec. 501(c)(3), Internal Revenue Code, as amended? 11. YES NO
- a. If "Yes," give the page and paragraph numbers. Page _____ Paragraph _____
- b. If "No," do these documents direct that on discontinuance of the organization the organization's assets are to be transferred to its members who have promised in their membership application to immediately transfer them to the State of Texas or to an educational, religious, charitable or other similar organization that is qualified for exemption under Sec. 501(c)(3), Internal Revenue code, as amended? b. YES NO
- c. If "Yes," give the page and paragraph numbers. Page _____ Paragraph _____
- d. If "Yes," was this two-step transfer required for the organization to qualify for exemption under Sec. 501(c)(3), Internal Revenue Code, as amended? d. YES NO

Step 5. Describe Your Property

PROPERTY TO BE EXEMPT:

- Attach one Schedule A (REAL PROPERTY) form for **EACH** parcel of real improved and unimproved property to be exempt.
- Attach one Schedule B (BUILDINGS) form for **EACH** building to be exempt.
- Attach one Schedule C (PERSONAL PROPERTY) form listing **ALL** personal property to be exempt.
- List only property owned by the organization.

Step 6. Sign the Application

- **By signing this application, you designate the property described in the attached Schedules A, B and C as the property against which the charitable organizations improving property for low-income housing exemption may be claimed in this appraisal district.**
- **You certify that this information is true and correct to the best of your knowledge and belief.**

On behalf of (name of organization)	Date
Authorized Signature sign here →	Title

If you make a false statement on this application, you could be found guilty of a Class A misdemeanor or a state jail felony under Texas Penal Code Section 37.10.



**TEXAS DEPARTMENT OF
HOUSING & COMMUNITY AFFAIRS**
Building Homes. Strengthening Communities.

TAB 34

Financing Scoring

Finance Scoring (for Competitive HTC Applications ONLY)

Self Score Total: 35

1. Commitment of Development Funding by Local Political Subdivision (§11.9(d)(2))

Name of the Local Political Subdivision providing the funding:

- A letter from an official of the political subdivision stating that the political subdivision will provide a loan, grant, reduced fees or contribution of other value type, and the terms under which it will be provided is in the application.
- The dollar value of the contribution must be in the letter and must equal \$500 or more if Urban and \$250 or more if Rural or USDA.
- The commitment of development funding is reflected in the Application as a financial benefit to the Development, i.e. reported as a source of funds on the Sources and Uses Form and/or reflected in a lower cost in the Development Cost Schedule, such as notation of a reduction in building permits and related costs.

Total Points Claimed: 0

2. Financial Feasibility (§11.9(e)(1))

- Eligible Pro-Forma and letter stating the Development is financially feasible. 0
- Eligible Pro-Forma and letter stating Development and Principals are acceptable. 0

Total Points Claimed: 0

3. Leveraging of Private, State, and Federal Resources (§2306.6725(a)(3); §11.9(e)(4))

Percent of Units restricted to serve households at or below 30% of AMGI 0.00%

HTC funding request as a percent of Total Housing Development Cost 0.00%

Eligibility for points:

- Development Leverages CDBG Disaster Recovery, HOPE VI, RAD or Choice Neighborhood Funding 0
- Housing Tax Credit Request 0
- Housing Tax Credit Request 0
- Housing Tax Credit Request 0

** Be sure no more than 50% of Developer fees are deferred.*

Total Points Claimed:



**TEXAS DEPARTMENT OF
HOUSING & COMMUNITY AFFAIRS**

Building Homes. Strengthening Communities.

TAB 35

**Supporting
Documentation**

Supporting Documents Should be Included Behind this Tab

ALL SUPPORTING DOCUMENTS MUST BE CONSISTENT WITH THE SOURCES AND USES

- Executed Pro Forma from Permanent or Construction Lender
- Letter from lender regarding approval of Principals (consistent with Template)
- Evidence of all Permanent and Construction Financing (term sheets, loan agreements)
- Evidence of any Gap Financing, terms included
- Evidence of any Owner Contributions, with financial support if required
- Evidence of Equity Financing (HTC applications only)
- Letter from Texas Historical Commission (THC) indicating preliminary eligibility for historic (rehabilitation) tax credits and documentation of Certified Historic Structure status as detailed in QAP §11.9(e)(6) was submitted behind TAB 19.
- Letter from Local Political Subdivision evidencing a loan, grant, reduced fees or contribution of other value to benefit the Development. [QAP §11.9(d)(2)]
- Evidence of Rental Assistance/Subsidy





8710 Greenville Ave. Suite A
Dallas, TX 75243
(469) 730-4159 Ext. 1003
FMartinez@rockhallfunding.com

February 28, 2018

Arlinda Homes Supportive Housing
Attn: Mr. Rick Sims
2002 Hwy 21 East
Bryan Texas 77803

Re: Arlinda Homes Supportive Housing

Dear Mr. Sims:

Rockhall Funding Corp is pleased to provide the following term sheet for construction and permanent financing to Arlinda Homes Limited LTD (the "Borrower") for the development of Arlinda Homes Supportive Housing, a Supportive Housing 30-unit HOME project to be built in Bryan, Texas. The proposed term and conditions are as follows:

Summary of Terms

- Borrower:** Arlinda Homes Limited LTD
- Guaranty:** Rick Sims and/or a corporate entity will provide construction loan and completion guarantees. The permanent loan will be non-recourse except as to "bad-boy" carve outs.
- Project:** Arlinda Homes Supportive Housing 30 Units
- Credit Facilities:**
- A) Construction loan of up to \$2,500,000
 - Priced at a variable rate of Prime Floating subject to a minimum all-in rate of 5.25% (floor of 4.75%)
 - 30-month construction loan term
 - One 6-month extension subject to 1) completion of project, 2) project sources and uses being balanced, 3) receipt of required HOME payments, 4) No event of default has occurred or potential for default to occur, 5) 85% occupancy and 6) No material adverse change in the financial condition of the Project, Borrower and Guarantor(s).
 - Interest only due monthly during construction period
 - Total construction loan period includes extension is 36-months

- B) Permanent loan of approximately \$2,500,000 at an assumed underwriting rate of interest of 5.25%
- Permanent loan rate to be locked at no later than construction loan closing of 30-month construction loan. The permanent loan rate would be 5.25% locked today.
 - 40-year term upon conversion to permanent status based on 90% occupancy for 90 days and a 1.15:1 debt service coverage.
 - Zero pre-payment penalty – you may pre-pay the construction or permanent loan off at any time without penalty.
 - Principal and interest due monthly during permanent period based on a 40-year amortization; balloon payment due at maturity
 - Replacement reserves to be \$300 per unit per year with agreed upon increases for future years. Operating deficit and other reserve requirements subject to Bank review and approval. It is expected that these reserve requirements will mirror the equity LOI.

Note: Construction draws will be processed through the Lender, Title Company, and with approval of a 3rd party construction engineering firm hired by or acceptable to the Lender.

- Loan-to-value:**
- 1) Actual loan amount will be based on LTV not to exceed 80% during construction period, based on rent-restricted values plus value of the tax credits;
 - 2) LTV not to exceed 80% during permanent period, based on stabilized tent-restricted value. Appraisal report will be in form and substance acceptable to the Lender.
- Collateral:**
- 1st lien deed of trust and assignment of leases and rents on the subject property
 - UCC filing on furniture, fixtures, and equipment
 - Assignment of Tax Credit
 - Security interest in operating and replacement reserve funds
 - Assignment and subordination of deferred developer fee and other management fees collected by general partner or a related entity
 - Assignment and subordination of management, construction, architectural contracts, etc...
- Fees:**
- Origination fee of 1.00% of the construction loan (payable at construction loan closing), a .25% fee for the extension (payable upon exercise) and a 1.00% fee for the permanent loan (payable at construction loan closing). Borrower will also pay for all reasonable costs incurred by the Lender in connection with the loans including, but not limited to, legal fees and expenses, appraisal/ survey fees, title insurance premiums and search fees, UCC searches, environmental assessment fees, and inspecting architect fees, and inspecting architect fees, whether or not the facilities contemplated herein are funded. This obligation will survive whether or not the loans are approved.

Reporting Requirements: Include but are not limited to:

- Annual audited financial statements of Borrower

- Annual financial statements of Guarantor
- Annual evidence of TDHCA compliance
- Monthly operating statements on the property once construction is complete
- Quarterly operating statements on the property during the permanent loan period

Summary of Conditions

This proposal is subject to all of the following conditions being met prior to construction closing:

HOME Funding Allocation:	Receipt of an allocation of HOME Funding from the Texas Department of Housing & Community Affairs (TDHCA) is a minimum amount of \$2,500,000
HOME Funding:	HOME Funding and any other equity terms (include price and pay-in schedule) subject to Lender approval.
Development Fee:	Timing of payment of developer profit to be mutually agreed upon between Lender and Borrower. It is expected that the developer fee payment will mirror the developer fee payment schedule negotiated in equity LOI.
Project Budget:	The Lender's current understanding of the project is based on the budget and pro forma numbers provided in the TDHCA HOME application. The Lender acknowledges that this project budget is subject chance. However, significant changes to the budget that materially affect the project may result in changes to the terms and conditions proposed herein.
Other Conditions:	Receipt and approval of those items listed in the Due Diligence Checklist.

Please note that in providing this proposal for submission to TDHCA as part of the applications process to get an award of HOME Funding, the Lender acknowledges the following:

- 1) Lender has reviewed the sponsor's application for the proposed development and finds that the project is feasible for financing the 30-year pro forma that the Lender finds acceptable which demonstrates a debt service coverage of no less than 1.15x for 30 years.
- 2) Lender has reviewed the creditworthiness and quality of the principals involved and has determined that the principals are acceptable to the Lender.
- 3) Lender has reviewed in substance, the credit worthiness and quality of the financial strength by the guarantors as noted above and finds such guarantors acceptable as part of the financing outlined in this proposal.

In summary, the Lender's assessment find both the Development and the Principals are acceptable.



This discussion letter does not represent a commitment by the Lender for the proposed financing, nor does it define all the terms and conditions of loan documents, but is framework upon which a loan request may be submitted and considered. Issuance of a commitment by the Lender is subject to the approval of the loan request under the Lender's internal approval process, which includes, but not limited to, a review of the Borrower's then current financial condition and review and approval of all third party reports, in addition to completion of loan documents in form and substance acceptable to the Lender.

If you should have any questions concerning these terms and conditions, please feel free to call me at (469) 730-4159. Rick, thank you for giving us the opportunity to consider financing for this project.

Sincerely,

A handwritten signature in blue ink, appearing to read 'Frank J. Martinez', written over a horizontal line.

By: _____
Name: Frank J. Martinez, Regional Senior Loan Consultant

Agreed to: Arlinda Homes Limited LTD:

By: Arlinda Homes Limited LTD its general partner

By: _____
Rick Sims, Managing Partner



**TEXAS DEPARTMENT OF
HOUSING & COMMUNITY AFFAIRS**
Building Homes. Strengthening Communities.

TAB 36

Sponsor Characteristics

Sponsor Characteristics (Competitive HTC Only)

Self Score Total: **124**

Pursuant to §11.9(b)(2) of the Qualified Allocation Plan, an Application may qualify to receive up to one (1) point provided the ownership structure meets one of the following requirements in parts 1 or 2 below;

1. Application is attempting to score as a Qualified Nonprofit and meets the criteria below:

Yes Application is applying under the Nonprofit Set-Aside, and

Yes The Qualified Nonprofit has some combination of ownership interest, cash flow from operations, and developer fee which taken together equal at least 80% and no less than 5% for any category.

Ownership Interest: 80.000%

Cash flow from operations: 80.000%

Developer Fee: 80.000%

Total: 240.00%

Yes The Qualified Nonprofit will materially participate in the Development and the operation of the Development throughout the Compliance Period. 

The Qualified Nonprofit has experience directly related to the housing industry. (mark all that apply)

Property Management Construction Development Financing Compliance

No Principals of the Qualified Nonprofit are related Parties to any other Principals of the Applicant or Developer.

Evidence of experience in the housing industry and a statement regarding material participation are provided behind this tab.

Eligible Points: **1**

2. Application is attempting to score as a HUB and meets the criteria below:

The ownership structure contains a HUB, and evidence from the Texas Comptroller of Accounts is provided behind this Tab.

No The HUB has some combination of ownership interest, cash flow from operations, and developer fee which taken together equal at least 80% and no less than 5% for any category.

Ownership Interest: **CANNOT BE LESS THAN 5%**

Cash flow from operations: **CANNOT BE LESS THAN 5%**

Developer Fee: **CANNOT BE LESS THAN 5%**

Total: 0.00%

The HUB will materially participate in the Development and the operation of the Development throughout the Compliance Period. 

The HUB has experience directly related to the housing industry. (mark all that apply)

Property Management Construction Development Financing Compliance

No Principals of the HUB are related Parties to any other Principal of the Applicant or Developer. 

Evidence of experience in the housing industry and a statement regarding material participation are provided behind this tab.

Eligible Points: **0**

Total Points Claimed: **1**



**TEXAS DEPARTMENT OF
HOUSING & COMMUNITY AFFAIRS**
Building Homes. Strengthening Communities.

TAB 37

**Applicant and
Development
Ownership Charts**

Owner and Developer Organization Charts

Applicants should note that subsequent changes to the Development Ownership structure presented in this section will require the written consent of the Department.

Pursuant to §10.204(13)(A) of the Uniform Multifamily Rules, submit three separate charts. One showing the complete organizational structure of each of the following entities: Development Owner, Developer, and Guarantor.

The organization charts must include:

- The names and ownership percentages of all Persons having an ownership interest in the Development Owner, Developer, and/or Guarantor.
- Nonprofit entities, public housing authorities, publicly traded corporations, individual board members and executive directors must be included in Organization charts.
- Any and all trusts must list all beneficiaries that have the legal ability to control or direct activities of the trust and are not just financial beneficiaries.

In the case of:

- (A) Partnerships - Principals include all general Partners and Special LPs (any LP that is not the Syndicator is a "Special LP");
- (B) Corporations - Principals include the executive director and all members of the board (shown with "0%" ownership as applicable). For to-be formed instrumentalities of PHAs, where the executive director and board remain to be determined, include the PHA, itself, and its members;
- (C) Limited liability companies - Principals include all the managing members and all other members.

Org. Chart Example:

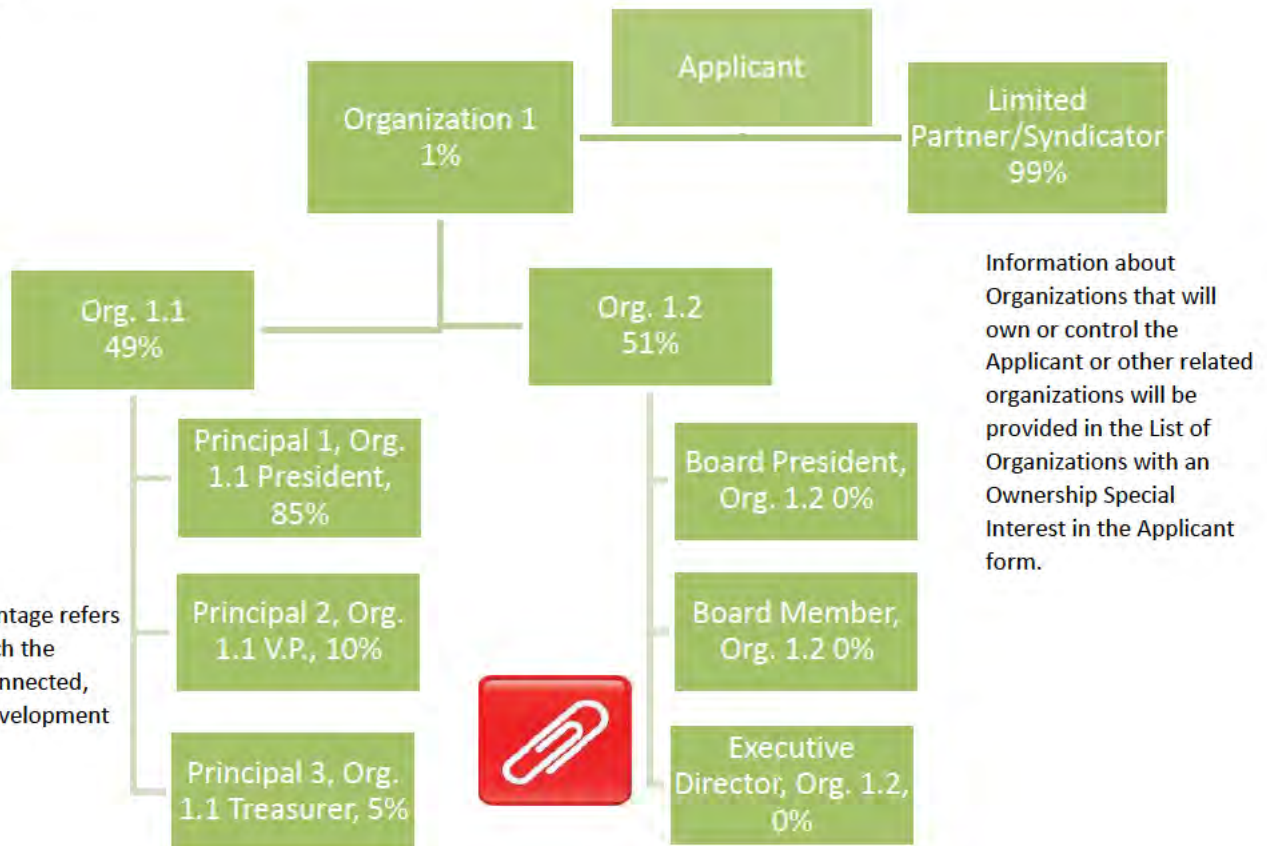

DEVELOPMENT CHART

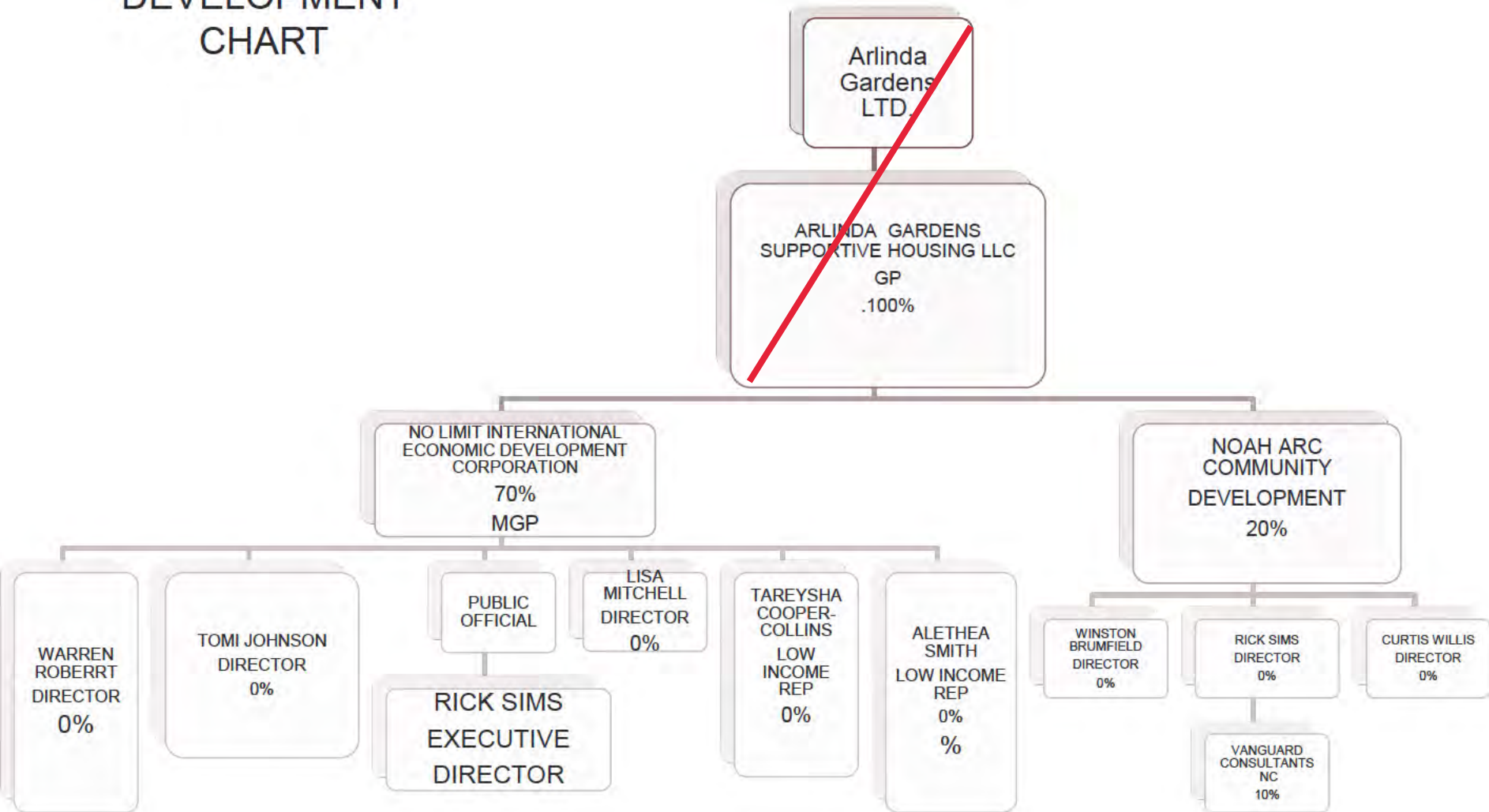

OWNERSHIP CHART

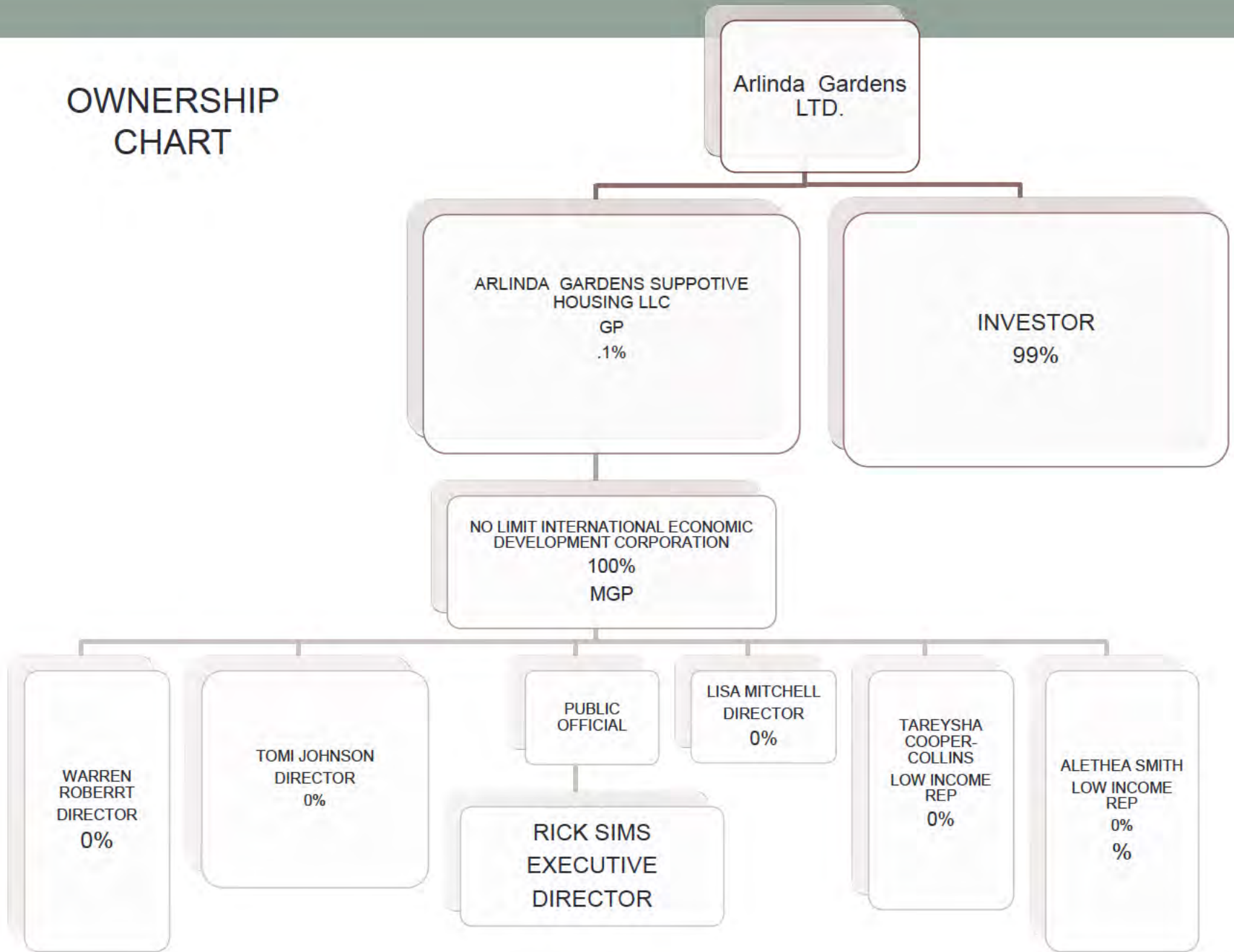



**TEXAS DEPARTMENT OF
HOUSING & COMMUNITY AFFAIRS**
Building Homes. Strengthening Communities.

TAB 38

List of Organizations and Principals

List of Organizations and Principals

Provide the requested information for all partnerships, corporations, limited liability companies, trusts, or any other public or private entity and their Affiliates identified on the Owner and Developer Organization Charts. Organizations that own or control other organizations should also be identified until the only remaining sub-entity would be natural persons. Organizations that are Developers and/or Guarantors must also be listed on this form as must any organization (and natural person whose ownership interest in an applicable entity is direct instead of via membership in an organization) that will receive more than 10% of the developer fee. (Note - Entity Names, Principals, and ownership percentage should coincide with the Owner and Developer Organization Charts)

Applicant Legal Name: <u>Arlinda Gardens, LTD</u>	
Address: <u>420 Walnut St.</u>	City: <u>Minden</u> State: <u>LA</u> Zip: <u></u>
Name(s) of Entities the Organization Owns or Controls: <u></u>	
Organization legally formed? <u>No</u>	Date formed: <u>TBD</u> Legal Org is or will be: <u>Non-Profit</u>
Previous TDHCA Experience? <u>No</u>	Phone: <u>#####</u> Email: <u>rrsims90@aol.com</u>

Org. 1

Organization Legal Name: <u>Arlinda Gardens Supportive Housing, LLC</u>		Role/Title: <u>General Partner</u>
Address: <u>420 Walnut St.</u>	City: <u>Mindaen</u> State: <u>LA</u> Zip: <u></u>	
Name(s) of Entities the Organization Owns or Controls: <u>Arlinda Gardens, LTD</u>		
Organization legally formed? <u>No</u>	Date formed: <u>TBD</u>	Legal Org is or will be: <u>Limited Liability Company</u>
Previous TDHCA Experience? <u>No</u>	Phone: <u>3183491588</u>	Email: <u>rrsims90@aol.com</u>
Organization is identified on Org. Chart: <u>Yes</u>	Ability to exercise Control over the Development? <u>Yes</u>	
List of Sub-Entities or Principals:		
1. <u>Noah Arc Community Development Corporation</u>	2. <u>International Economic Development (</u>	3. <u>Rick Sims</u>
TDHCA Experience: <u>No</u>	TDHCA Experience: <u>No</u>	TDHCA Experience: <u>Yes</u>
4. <u></u>	5. <u></u>	6. <u></u>
TDHCA Experience: <u></u>	TDHCA Experience: <u></u>	TDHCA Experience: <u></u>

Org.

Organization Legal Name: <u>No Limits International Economic Development Corporation</u>		Role/Title: <u>Member</u>
Address: <u>2002 Highway 21 East</u>	City: <u>Bryan</u> State: <u>TX</u> Zip: <u>77803</u>	
Name(s) of Entities the Organization Owns or Controls: <u>Arlinda Gardens Supportive Housing, LLC</u>		
Organization legally formed? <u>Yes</u>	Date formed: <u>5/24/2007</u>	Legal Org is or will be: <u>Non-Profit</u>
Previous TDHCA Experience? <u>No</u>	Phone: <u>9795754577</u>	Email: <u>tbroberts40@yahoo.com</u>
Organization is identified on Org. Chart: <u>Yes</u>	Ability to exercise Control over the Development? <u>Yes</u>	
List of Sub-Entities or Principals:		
1. <u>Warren Roberts</u>	2. <u>Tomi Johnson</u>	3. <u>Lisa Mitchell</u>
TDHCA Experience: <u>No</u>	TDHCA Experience: <u>No</u>	TDHCA Experience: <u>No</u>
4. <u>Rick R. Sims</u>	5. <u></u>	6. <u></u>
TDHCA Experience: <u>Yes</u>	TDHCA Experience: <u></u>	TDHCA Experience: <u></u>

Org.

Organization Legal Name: <u>Noah Arc Community Development Corporation</u>		Role/Title: <u>Member</u>
Address: <u>420 Walnut St</u>	City: <u>Minden</u> State: <u>LA</u> Zip: <u>71055</u>	
Name(s) of Entities the Organization Owns or Controls: <u>n/a</u>		
Organization legally formed? <u>Yes</u>	Date formed: <u>12/10/2015</u>	Legal Org is or will be: <u>Non-Profit</u>
Previous TDHCA Experience? <u>No</u>	Phone: <u>3183491588</u>	Email: <u>rrsims90@aol.com</u>
Organization is identified on Org. Chart: <u></u>	Ability to exercise Control over the Development? <u>Yes</u>	
List of Sub-Entities or Principals:		
1. <u>Rick Sims</u>	2. <u>Winston Brumfield</u>	3. <u>Mark Dones</u>
TDHCA Experience: <u>Yes</u>	TDHCA Experience: <u>No</u>	TDHCA Experience: <u>No</u>
4. <u></u>	5. <u></u>	6. <u></u>
TDHCA Experience: <u></u>	TDHCA Experience: <u></u>	TDHCA Experience: <u></u>

Org.

Organization Legal Name: _____ Role/Title _____

Address: _____ City: _____ State: _____ Zip: _____

Name(s) of Entities the Organization Owns or Controls: _____

Organization legally formed? Date formed: _____ Legal Org is or will be: _____

Previous TDHCA Experience? Phone: _____ Email: _____

Organization is identified on Org. Chart: Ability to exercise Control over the Development?

List of Sub-Entities or Principals:

1. _____	2. _____	3. _____
TDHCA Experience: _____	TDHCA Experience: _____	TDHCA Experience: _____
4. _____	5. _____	6. _____
TDHCA Experience: _____	TDHCA Experience: _____	TDHCA Experience: _____

Org.

Organization Legal Name: _____ Role/Title _____

Address: _____ City: _____ State: _____ Zip: _____

Name(s) of Entities the Organization Owns or Controls: _____

Organization legally formed? Date formed: _____ Legal Org is or will be: _____

Previous TDHCA Experience? Phone: _____ Email: _____

Organization is identified on Org. Chart: Ability to exercise Control over the Development?

List of Sub-Entities or Principals:

1. _____	2. _____	3. _____
TDHCA Experience: _____	TDHCA Experience: _____	TDHCA Experience: _____
4. _____	5. _____	6. _____
TDHCA Experience: _____	TDHCA Experience: _____	TDHCA Experience: _____

Org.

Organization Legal Name: _____ Role/Title _____

Address: _____ City: _____ State: _____ Zip: _____

Name(s) of Entities the Organization Owns or Controls: _____

Organization legally formed? Date formed: _____ Legal Org is or will be: _____

Previous TDHCA Experience? Phone: _____ Email: _____

Organization is identified on Org. Chart: Ability to exercise Control over the Development?

List of Sub-Entities or Principals:

1. _____	2. _____	3. _____
TDHCA Experience: _____	TDHCA Experience: _____	TDHCA Experience: _____
4. _____	5. _____	6. _____
TDHCA Experience: _____	TDHCA Experience: _____	TDHCA Experience: _____

Org.

Organization Legal Name: _____ Role/Title _____

Address: _____ City: _____ State: _____ Zip: _____

Name(s) of Entities the Organization Owns or Controls: _____

Organization legally formed? Date formed: _____ Legal Org is or will be: _____

Previous TDHCA Experience? Phone: _____ Email: _____

Organization is identified on Org. Chart: Ability to exercise Control over the Development?

List of Sub-Entities or Principals:

1. _____	2. _____	3. _____
TDHCA Experience: _____	TDHCA Experience: _____	TDHCA Experience: _____
4. _____	5. _____	6. _____
TDHCA Experience: _____	TDHCA Experience: _____	TDHCA Experience: _____



**TEXAS DEPARTMENT OF
HOUSING & COMMUNITY AFFAIRS**
Building Homes. Strengthening Communities.

TAB 39

**Previous Participation
Form**

Previous Participation Form

Form must be completed separately for each entity (i.e. person, organization, etc.) that has or will have a controlling interest or oversight in the contract, award, agreement, or ownership transfer being considered. This form should also be completed for each board member, individual with

Person/Role: Rick Sims

Email Address: rrsims90@aol.com

City & State of Home Addr: Minden, LA

Applicant Legal Name: Arlinda Gardens, LTD

1. List experience with all TDHCA rental development programs (including: HTC, HTC Exchange, Direct Loan (HOME, TCAP, RHD), and BOND) that you have controlled at any time.

By selecting this box I certify that I have no prior experience with any TDHCA administered affordable rental program.

TDHCA ID#	Property Name	Property City	Program	Control began (mm/yy)	Control End (mm/yy)
7306	Zion Village Senior Apartments	Houston	9%	Dec-17	
10035	Zion Garden	Houston	9%	Dec-17	

2. Identify all Community Affairs and Single Family department programs that you have participated in within the last three(3) years by placing an "x" next to the program name.

By selecting this box I certify that I have no prior experience with any TDHCA Single Family or Community Affairs Programs.

Community Affairs:	CEAP		DOE		HHSP		WAP	
	CSBG		ESG		LIHEAP			
HOME:	CFDC		HBA		PWD		TBRA	
	DR		HRA		SFD			
HTF/OCI:	AYBR		Bootstrap		CFDC		Self-Help	
Other:							NSP	



**TEXAS DEPARTMENT OF
HOUSING & COMMUNITY AFFAIRS**
Building Homes. Strengthening Communities.

TAB 40

Nonprofit Participation

Nonprofit Participation

Nonprofit Set-Aside (Competitive HTC Applications Only)

Qualification: Must meet the definition of a Qualified Nonprofit Development pursuant to §10.3(a)(102) of the Uniform Multifamily Rules, §42(h)(5) of the code, and the requirements of §11.5(1) of the Qualified Allocation Plan.

Documentation: Eligibility will be confirmed based upon completion of the Nonprofit Participation and Additional Nonprofit Documentation requirements in this section.

By selecting this box the Applicant affirms the election to be included in the Nonprofit Set-Aside and certifies that they expect to receive a benefit in the allocation of tax credits as a result of being affiliated with a nonprofit.

By selecting this box the Applicant affirms the election to be excluded from the Nonprofit Set-Aside and certifies that they do not expect to receive a benefit in the allocation of tax credits as a result of being affiliated with a nonprofit.

ERROR: Nonprofit Set-Aside must be elected on Dev. Narr. Tab if electing to participate in the Set-Aside.

Nonprofit Information (ALL Applications)

Only nonprofit organizations will complete this section. All nonprofit Applicants or Principals must complete this form without regard to their level of ownership or the set-aside under which the Application was made.

Organization Name: No Limits International Economic Development Corporation

Is the Organization a 501(c)(3) or (4) as of the beginning of the Application Acceptance Period? Yes

If no to the question above, what is its current legal status?

If "Other" please specify:

Date of legal formation of Nonprofit Organization: 5/24/2007

1) Is Applicant comprised of a joint venture between a Nonprofit and for-profit entity? No

If "Yes", will this nonprofit organization Control the Applicant? Yes

What is the ownership percentage of this nonprofit organization? 99

2) Describe the nonprofit's participation: The CHDO is the primary participant

3) Describe the nonprofit's participation in the operation of the Development throughout the Compliance and/or extended use period:

The CHDO will carryout the development accoring to it Bylaws and accounting policies and procedures policies

4) Will the nonprofit receive part of the development fees paid in connection with the development?

If "Yes," explain: The CHDO has decided that the deve;loper fees are to first finance lowe rent

LIST OF THE NONPROFIT ORGANIZATION'S BOARD MEMBERS, DIRECTORS AND OFFICERS

Warren Roberts		President	
Name	Title		
2017 Old Hearne Rd	Bryan	TX	77803
Address	City	State	Zip
	tbroberts40@yahoo.com	Pastor	
Phone	Ext.	Fax or Email	Occupation
Tomi Johnson		Vice President	
Name	Title		
2326 Yellowstone Dr	Bryan	TX	77803
Address	City	State	Zip
		Administration	
Phone	Ext.	Fax or Email	Occupation
Lisa Mitchell		Director	
Name	Title		
1007 S FM 908	Rockdale	TX	76567
Address	City	State	Zip
(512) 867-1323		Administration	
Phone	Ext.	Fax or Email	Occupation
Alethea Smith		Low Income Representative	
Name	Title		
5004 Stevenson St	Bryan	Tx	77807
Address	City	State	Zip
		Clerical	
Phone	Ext.	Fax or Email	Occupation
Tareysha Cooper-Collins		Low Income Rep	
Name	Title		
6694 Allen Rd	Bryan	TX	77807
Address	City	State	Zip
		Clerical	
Phone	Ext.	Fax or Email	Occupation
Name	Title		
		State	Zip
Address	City		
		Occupation	
Phone	Ext.	Fax or Email	
Name	Title		
		State	Zip
Address	City		
		Occupation	
Phone	Ext.	Fax or Email	



**TEXAS DEPARTMENT OF
HOUSING & COMMUNITY AFFAIRS**
Building Homes. Strengthening Communities.

TAB 41

**Nonprofit Support
Documentation**

Nonprofit Supporting Documents Should be Included Behind this Tab

Applications involving a Qualified Nonprofit Organization pursuant to Texas Government Code, §2306.6706 that have a 501(c)(3) or 501(c)(4) designation at the time of Application and competitive 9% HTC Applications electing to compete under the Nonprofit Set-aside must provide the following documentation behind this tab:

- IRS determination letter
- Third Party legal opinion (not applicable to Tax-Exempt Bond Developments)
- The Nonprofit's most recent financial statement as prepared by a Certified Public Accountant (not applicable to Tax-Exempt Bond Developments)
- Certification regarding Board member residence (not applicable to Tax-Exempt Bond Developments)



INTERNAL REVENUE SERVICE
P. O. BOX 2508
CINCINNATI, OH 45201

DEPARTMENT OF THE TREASURY

Date: **MAR 12 2012**

NO LIMITS INTERNATIONAL ECONOMIC
DEVELOPMENT CORPORATION
C/O WARREN ROBERTS
2002 HIGHWAY 21 EAST
BRYAN, TX 77806

Employer Identification Number:
26-1604610
DLN:
17053032399012
Contact Person:
WILLIAM SCHRODER ID# 31694
Contact Telephone Number:
(877) 829-5500
Accounting Period Ending:
December 31
Public Charity Status:
170(b)(1)(A)(vi)
Form 990 Required:
Yes
Effective Date of Exemption:
May 15, 2011
Contribution Deductibility:
Yes
Addendum Applies:
Yes

Dear Applicant:

We are pleased to inform you that upon review of your application for tax exempt status we have determined that you are exempt from Federal income tax under section 501(c)(3) of the Internal Revenue Code. Contributions to you are deductible under section 170 of the Code. You are also qualified to receive tax deductible bequests, devises, transfers or gifts under section 2055, 2106 or 2522 of the Code. Because this letter could help resolve any questions regarding your exempt status, you should keep it in your permanent records.

Organizations exempt under section 501(c)(3) of the Code are further classified as either public charities or private foundations. We determined that you are a public charity under the Code section(s) listed in the heading of this letter.

Please see enclosed Publication 4221-PC, Compliance Guide for 501(c)(3) Public Charities, for some helpful information about your responsibilities as an exempt organization.

Letter 947 (DO/CG)

NO LIMITS INTERNATIONAL ECONOMIC

Sincerely,

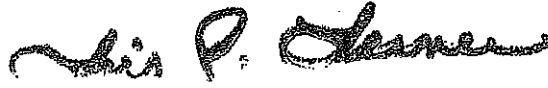
A handwritten signature in cursive script, appearing to read "Lois G. Lerner".

Lois G. Lerner
Director, Exempt Organizations

Enclosure: Publication 4221-PC

NO LIMITS INTERNATIONAL ECONOMIC

We considered and approved your request for retroactive reinstatement under Notice 2011-43.

OGDEN UT 84201-0038

In reply refer to: 0437870217
Feb. 13, 2013 LTR 4168C 0
26-1604610 000000 00
00035726
BODC: TE

NO LIMITS INTERNATIONAL ECONOMIC
DEVELOPMENT CORPORATION
% WARREN ROBERTS
2002 HIGHWAY 21 E
BRYAN TX 77803-2830

032029

Employer Identification Number: 26-1604610
Person to Contact: Exempt Organizations
Toll Free Telephone Number: 1-877-829-5500

Dear Taxpayer:

This is in response to your Feb. 04, 2013, request for information regarding your tax-exempt status.

Our records indicate that you were recognized as exempt under section 501(c)(3) of the Internal Revenue Code in a determination letter issued in March, 2012.

Our records also indicate that you are not a private foundation within the meaning of section 509(a) of the Code because you are described in section(s) 509(a)(1) and 170(b)(1)(A)(vi).

Donors may deduct contributions to you as provided in section 170 of the Code. Bequests, legacies, devises, transfers, or gifts to you or for your use are deductible for Federal estate and gift tax purposes if they meet the applicable provisions of sections 2055, 2106, and 2522 of the Code.

Please refer to our website www.irs.gov/eo for information regarding filing requirements. Specifically, section 6033(j) of the Code provides that failure to file an annual information return for three consecutive years results in revocation of tax-exempt status as of the filing due date of the third return for organizations required to file. We will publish a list of organizations whose tax-exempt status was revoked under section 6033(j) of the Code on our website beginning in early 2011.

OGDEN UT 84201-0038

032029.156028.0141.003 1 MB 0.405 536
|||...|||



NO LIMITS INTERNATIONAL ECONOMIC
DEVELOPMENT CORPORATION
% WARREN ROBERTS
2002 HIGHWAY 21 E
BRYAN TX 77803-2830

032029

CUT OUT AND RETURN THE VOUCHER AT THE BOTTOM OF THIS PAGE IF YOU ARE MAKING A PAYMENT,
EVEN IF YOU ALSO HAVE AN INQUIRY.



The IRS address must appear in the window.

Use for payments

BODCD-TE

0437870217

Letter Number: LTR4168C
Letter Date : 2013-02-13
Tax Period : 000000

INTERNAL REVENUE SERVICE

OGDEN UT 84201-0038

|||...|||



261604610

NO LIMITS INTERNATIONAL ECONOMIC
DEVELOPMENT CORPORATION
% WARREN ROBERTS
2002 HIGHWAY 21 E
BRYAN TX 77803-2830

261604610 SW NOLI 00 2 000000 670 000000000000

**No Limits International Economic
Development Corporation**

Financial Statements
For the Year Ended December 31, 2015



Ingram, Wallis & Co., P.C.

No Limits International Economic
Development Corporation

Financial Statements

For the Year Ended December 31, 2015



Ingram, Wallis & Co., P.C.

CERTIFIED PUBLIC ACCOUNTANTS

To the Board of Directors of
No Limits International Economic Development Corporation

Management is responsible for the accompanying financial statements of No Limits International Economic Development Corporation (a nonprofit organization), which comprise the statement of financial position as of December 31, 2015, and the related statement of activities for the year then ended in accordance with accounting principles generally accepted in the United States of America. We have performed a compilation engagement in accordance with Statements on Standards for Accounting and Review Services promulgated by the Accounting and Review Services Committee of the AICPA. We did not audit or review the financial statements nor were we required to perform any procedures to verify the accuracy or completeness of the information provided by management. Accordingly, we do not express an opinion, a conclusion, or provide any form of assurance on these financial statements.

Management has elected to omit substantially all of the disclosures and the statement of cash flows required in financial statements prepared in accordance with accounting principles generally accepted in the United States of America. If the omitted disclosures and the statement of cash flows were included in the financial statements, they might influence the user's conclusions about the Organization's financial position, changes in net assets, and cash flows. Accordingly, the financial statements are not designed for those who are not informed about such matters.

Bryan, Texas
October 28, 2016

Ingram, Wallis & Company

No Limits International Economic Development Corporation
Statement of Financial Position
December 31, 2015

Assets

Current Assets

Cash	\$ 20,902
Inventory - Construction in Progress	<u>69,523</u>

Total Current Assets	<u>90,425</u>
----------------------	---------------

Property and Equipment

Buildings	110,266
Equipment	851
Accumulated Depreciation	<u>(4,297)</u>

Net Property & Equipment	<u>106,820</u>
--------------------------	----------------

Other Assets

Note Receivable	<u>15,600</u>
-----------------	---------------

Total Assets	<u><u>\$ 212,845</u></u>
--------------	--------------------------

Liabilities and Net Assets

Current Liabilities

Construction Loan - 6102779	<u>\$ 2,014</u>
-----------------------------	-----------------

Noncurrent Liabilities

Construction Loan - 6102430	17,595
Note Payable - Pruitt	<u>81,268</u>

Total Noncurrent Liabilities	<u>98,863</u>
------------------------------	---------------

Total Liabilities	<u>100,877</u>
-------------------	----------------

Net Assets

Unrestricted	<u>111,968</u>
--------------	----------------

Total Liabilities and Net Assets	<u><u>\$ 212,845</u></u>
----------------------------------	--------------------------

See accountants' compilation report.

No Limits International Economic Development Corporation
Statement of Activities
For the Year Ended December 31, 2015

	<u>Unrestricted</u>
Revenue and Other Support	
Home Sales	\$ 379,110
Less: Cost of Sales	<u>(352,844)</u>
Net Gain/(Loss)	<u>26,266</u>
Miscellaneous	669
Rent	<u>10,283</u>
Total Revenue and Other Support	<u>37,218</u>
Expenses	
Utilities	142
Fees	202
Website	1,050
Property Taxes	3
Insurance	3,436
Interest	10,266
Depreciation	2,757
Professional Fees	4,855
Maintenance	3,205
Office Supplies	41
Contract Labor	15,000
Travel	489
Administrative	<u>23</u>
Total Expenses	<u>41,469</u>
Change in Net Assets	(4,251)
Net Assets at Beginning of Year	<u>116,219</u>
Net Assets at End of Year	<u><u>\$ 111,968</u></u>

See accountants' compilation report.

BY-LAWS
Of
NO LIMITS INTERNATIONAL
ECONOMIC DEVELOPMENT CORPORATION

ARTICLE I
NAME AND OFFICE

Section 1. Name. The name of the Corporation shall be **No Limits International Economic Development Corporation.**

Section 2. Offices. The principal office of the Corporation shall be located in Brazos County, Bryan, Texas, as shall be determined by the Board of Directors. Other places of business may be established within or without the State of Texas as designed by the Board of Directors.

Article II
PURPOSE

No Limits International Economic Development Corporation is organized and shall be operated exclusively for charitable and educational purposes, including for such purposes but without limitation:

- A. "To stimulate, create, develop, manage and provide safe, quality, affordable housing and supportive services which benefit low-income families, extremely low income families and other disadvantaged persons including but not limited to supportive housing for Veterans and Homeless Veterans, supportive housing for the Elderly, supportive housing for Persons with Disabilities and modernized supportive Housing Opportunities for Persons with AIDS."
- B. To provide a full service housing counseling agency and business counseling agency to the public in need of such services.
- C. To provide or make available the technical skills and knowledge needed to successfully undertake the construction or rehabilitation of residential or commercial property of the operation of a business consistent with the purpose of the Corporation.
- D. To establish and operate business enterprises consistent with the purpose of the Corporation.
- E. To conduct any other legal charitable and educational activities.

**ARTICLE III
CORPORATION POWERS**

The Corporation shall have all the powers which are not inconsistent with the law.

**ARTICLE IV
BOARD OF DIRECTORS**

Section 1. Power and Authority of the Board of Directors. Except as otherwise provided by law, all of the authority of the Corporation shall vest in and be exercised by the Board of Directors.

Section 2. Number. The number of Directors of the Corporation shall not be less than three (3) nor more than fifteen (15).

Section 3. Composition.

Every effort shall be made to insure that the Board composition is balanced with respect to: race and ethnicity; gender; age; geography; rural/urban; needed skills, experience and relationships.

- At least one Board of Directors will be a Certified Educator with a degree in Education, Counseling, or Child Development. This person needs to have worked education system as teacher, principal, or counselor for at least five years.
- At least one Board of Directors will be a Professional Business Owner with at least five years experience operating his/her own business.
- At least one Board of Directors will be a Licensed Real Estate Professional with at least five years experience in the Real Estate Field in the area of a Broker, Developer, Inspector, Appraiser, etc.
- At least one Board of Directors will be a Accounting / finance professional with a Bachelors Degree in Accounting or Finance and with at least five years experience in the accounting / finance field.
- At least one Board of Directors will be a Certified Medical Professional with a Degree in Nursing, Medicine, Biology, or any medical field and with at least five years experience in the medical field.

Section 4. Other qualifications.

- At least one-third of the board members must live in the community this corporation is serving.
- At least one Board of Directors shall be low-to-moderate income individual.
- Not more than one Board of Directors may be a Board of Directors of the same church.
- No two board members can be relatives to each other

Section 5. Term of Office. The term of office shall be three (3) years. Members of the initial board shall be elected to serve for first staggered term of office, then the Secretary of the Corporation shall assign each Director to a numbered group and shall make a chance selection between or among the numbered group (by selecting among numbered lots or by some other chance selection procedure.) The group corresponding to the number so chosen shall be subject to election to a staggered term at the meeting.

Section 6. Appointed / Election. The initial Board of Directors shall be appointed by the Corporation's Initial Registered Agent. Afterwards, the Directors shall be elected at the annual meeting by the Regular members for staggered two-year terms, but, when the annual meeting is not held or directors are not elected at the annual meeting, they may be elected at a special meeting called and held for that purpose.

Section 7. Vacancies. Any vacancy occurring in the Board of Directors shall be filled by majority vote of the Board of Directors for the remainder of the unexpired term.

Section 8. Resignations. Any Director may resign, which resignation shall be effective on giving written notice to the Secretary or within one week thereafter as may be specified in the notice. Any Director who shall be absent from three consecutive regular meetings of the Board or four regular meetings whether consecutive or not during the year shall be regarded as thereby resigning from the Board and shall be so notified by the Secretary.

Section 9. Removal. Any Director, except the Corporation's Initial Registered Agent, may be removed with or without cause by majority vote of the Board at a regular or special meeting of the Board upon 30 days written notice to the member to be considered for removal.

Section 10. Conflict of Interest. No Director shall vote on any matter in which, to his or her knowledge, the Director, the Director's immediate family or partner, or an organization in which the Director is serving as officer, trustee, partner, employee, or independent contractor has a direct or indirect financial interest as defined by the policies of the Board of Directors. A Director shall disclose fully the nature of any potential conflict of interest. Failure to do so shall cause removal from the Board.

Section 11. Compensation. No compensation shall be paid to Directors for their service as Directors.

Section 12. Reimbursement. Directors may be reimbursed by the Corporation solely for out-of-pocket expenses incurred in the performance of their duties for the Corporation.

ARTICLE V

BOARD OF DIRECTORS MEETINGS

Section 1. Quorum and Manner of Acting. A simple majority of the whole Board of Directors, a majority of whom shall be low-income persons or representatives of the low-income community, shall constitute a quorum. The act of the majority of the Directors present at a meeting which a quorum is present shall be the act of the Board of Directors except as otherwise required by statute, the Article of Incorporation, or these By-Laws. If no quorum is present, a majority of the Directors present may adjourn the meeting from time to time without notice.

Section 2. Annual Meeting. Annual meetings of the Board of Directors shall be held at such time and on such date in May of each fiscal year as may be fixed by the Board and stated in the notice of the meeting for the consideration of reports to be laid before such meeting; to review the annual audit, to elect members to the Board and to elect the officers of the Corporation and to transact such other business as may properly come before the meeting.

Section 3. Regular Meeting. The Board of Directors shall meet monthly. The Board of Directors, upon resolution, may provide the time and place for regular meetings of the Board, without special notice other than such resolution. Except as otherwise provided by statute, the Article of Incorporation, or these By-Laws, and all business may be transacted at any regular meeting.

Section 4. Special Meetings. The President of the corporation or any three (3) Directors may call special meetings of the Board of Directors. Special meetings shall be held in person at the date and time set by the President and shall be held at such times and places as may be specified in such call.

Section 5. Notice. Notice of any special meetings of the Board of Directors shall be provided by mail or telegram to each Director at the address indicated by the records of the Corporation at least ten (10) days not more than twenty-five (25) days prior to such meeting. This notice shall contain the date, time and place of such meetings, as well as a brief statement of purpose for the meeting. Attendance of a Director at any meeting shall constitute waiver of notice of such meeting.

Section 6. Action Without Meeting. Any action which may be taken at any meeting of the Board, or of any committee, may be taken without such meeting by one or more written documents signed by all directors sitting forth the action to be taken. The written action shall be filed with the secretary of the Corporation in the permanent records.

Section 7. Voting. Each member of the Board shall have one vote. There shall be no proxy voting.

ARTICLE VI COMMITTEES

Section 1. Standing Committees. There shall be three (3) standing committees, each of which shall consist of at least (2) Directors appointed by the Board of Directors, plus such other persons as the Board of Directors may appoint; provided, however, the total number of voting, non-Director committee members shall always be less than the number of voting Director committee members. The Board of Directors may appoint any number of non-voting committee members. A majority of voting members of each committee present at any committee meeting shall constitute a quorum. Vacancies in such committee shall be filled by the Board of by such other procedure as approved by the board.

Such committees, to the extent provided in said resolution, shall have and exercise the authority of the Board of Directors in the management of the Corporation. However, no such committee shall have the authority of the Board of Directors in reference to amending, altering, or repealing, the By-Laws, electing, appointing, or removing any member of any such committee or any Director or officer of the Corporation; amending the Article of Incorporation; adopting a plan of merger or adopting a plan of consolidation with another Corporation; authorizing the sale, lease, exchange or mortgage, or all or substantially all of the property and assets of the Corporation, or amending, altering, or repealing any resolution amended, altered or repealed by such committee. The designation and appointment of any such committee and the delegation thereto of authority shall not operate to relieve the Board of Directors, or any individual director, of any responsibility imposed on it, him or her, by law.

The names and general functions of the standing committees are as follows:

- 1) **Finance and Budget Committee.** The Finance and Budget Committee shall be responsible for fundraising, setting annual budgets, and overseeing the financial aspects of the Corporation.
- 2) **Operation Committee.** The Operation Committee shall monitor the general operation, activities and effectiveness of the Corporation including: developing personnel policies and procedures, office space and operations, evaluations of program components, liaison with other organizations, work program development; development of the annual work plan; and development and revision the strategic plan.
- 3) **Acquisition and Development Committee.** The Acquisition and Development Committee shall be responsible for locating undeveloped and developed properties and to coordinate with the Finance and Budget Committee for the acquisition and development of the properties.

Section 2. Other Board Committees. The Board of Directors may provide for such other standing of special committees as it deems desirable and discontinue these committees at its pleasure. Each such committee shall consist of two or more directors elected by the Board. Non-Directors may be appointed to committees with the consent of the Board. committees shall have such powers and perform such duties or functions, not inconsistent with law, as may be delegated to them by the Board. A majority of members of each committee present at any committee meeting shall constitute a quorum. Vacancies in such committees shall be filled by the Board.

Section 3. Other Committees and Advisory Groups. The Board of Directors may provide for such other committees and advisory groups, consisting in whole or in part of non-Directors, as it deems desirable and discontinue these committee and groups at its pleasure. Each such committee and group shall be advisory to the Board and shall have no power to act on behalf of the Corporation. Appointments to the filling of vacancies on such committees and groups shall be the responsibility of the Board of Directors.

The Advisory of the corporation is a community of residents in a specific geographical location appointed by the Board. The purpose of the group is to interpret the needs and interests of the community they represent and the corporation regarding programs, ideas, and activities that satisfy these needs and/or interests.

Section 4. Committee Reporting. Any action by any committee or group shall be reported to the Board at its next meeting after such action. Actions taken by any committee or group shall be subject to control, revision and alteration by the Board provided that no rights of third persons shall be prejudicially affected.

ARTICLE VII OFFICERS

Section 1. Officers. Officers of the Corporation shall be President, Vice President, Secretary, and Treasurer. The President may not hold, simultaneously, and other office of the Corporation. All officers shall be Board Members.

Section 2. Selection of Officers. The officers of the Corporation shall be elected by a majority of the Board of Directors at the Annual meeting.

Section 3. Term of Office. The term of office of any elected officer of the Corporation shall begin immediately following election and such officers shall serve for a period of one year or until his/her successor takes office.

Section 4. Removal of Officers. Any officer may be removed with or without cause by affirmative vote of a majority of the Board, accept the Corporation's Initial Registered Agent.

Section 5. Resignation. Any officer may resign at any time by giving written notice to the Board of Directors or the President or Secretary of the Corporation. Any such resignation shall take effect at the date of reception of such notice or at any later date specified therein and unless otherwise specified, the acceptance of a resignation shall not be necessary to make it effective.

Section 6. Duties of Officers.

(a) The President shall be the chief elected officer of the Corporation, shall preside at all business meetings, and shall be President of and preside at meeting of the Board. The President shall appoint the members of all committees except as otherwise specified in the By-Laws of the Corporation, and shall be ex-officio member of all committees without vote. She/he may sign with the secretary or any other proper officer of the Corporation authorized by the Board of

Directors, any deed, mortgage, bonds, contracts, or other instruments which the Board of Directors has authorized to be executed, except in cases where the signing and execution thereof shall be expressly delegated to some other officer or agent of the Corporation; and in general she/he shall perform all duties incident to the office of President and such other duties as shall be prescribed by Board of Directors from time to time.

(b) The Vice President shall serve as the President for meeting in absence of the President or in the event of his/her inability or refusal to act, conduction business as provided by the By-Laws of the Corporation.

(c) The Secretary shall keep the minutes of the meetings of the Board of Directors in one or more books provided for that purpose and shall submit these minutes for approval by the respective bodies; see that all notices are given in accordance with the By-Laws; be custodian of the Corporation's records; keep a register of the post-officer address for each member; and in general perform all the duties incident to the office of Secretary and such other duties as from time to time may be assigned by the Board of Directors. The Secretary shall be under such bond as may be determined by the Board.

(d) The Treasurer shall have charge and custody and be responsible for all funds and securities of the Corporation from any source whatsoever and deposit such monies in the name of the Corporation in such financial institution or investments as shall be elected in accordance with these By-Laws; and in general perform all the duties incident to the office of Treasurer and such other duties as from time to time may be assigned by the Board of Directors. The Treasurer shall be under such bond as may be determined by the Board.

ARTICLE VIII CONDUCT OF THE BUSINESS OF THE CORPORATION

Section 1. Raising of Funds. The Board of Directors shall be responsible for the solicitation and raising of funds to finance the operations of the Corporation.

Section 2. Distribution of Funds. The Board of Directors shall determine the allocation of funds for each fiscal year and reallocation during the year.

Section 3. Contracts. The Board of Directors may authorize and officer or agent of the Corporation in addition to the officers authorized by these By-Laws, to enter into any contract or execute and deliver any instrument in the name of and on the behalf of the Corporation, and such authority may be general or confined to specific instances.

Section 4. Checks, Drafts, Etc. All checks, drafts, or orders for the payment of money, notes, or other evidence of indebtedness issued in the name of the Corporation, shall be signed by such persons and manner as shall from time to time be determined by resolution of the Board of Directors. In the absence of such determination by the Board of Directors, such instrument shall be signed by the Treasurer or Assistant Treasurer and countersigned by the President or Vice President of the Corporation.

Section 5. Deposits. All funds of the Corporation shall be deposited from time to time to the credit of the Corporation in such banks, savings and loan associations, trust companies, and other depositories as the Board of Directors may elect.

Section 6. Investments. The Corporation shall have the right to retain all or any part of any property, real, personal, tangible, acquired by it in whatever manner, and pursuant to the direction and judgment of the Board, to invest and reinvest any funds held by it without being restricted to the class of investments available to directors by law or any similar restriction; provided, however, that no action shall be taken by or on behalf of the Corporation if such action would result in denial or revocation of the Corporation's exemption from federal income taxation under the Internal Revenue Code and its regulations.

Section 7. Gifts and Loans. The Board of Directors may accept on behalf of the Corporation any contribution, gift, bequest, devise, or loan for the general purpose or for any special purposes of the Corporation.

Section 8. Annual Report. Not less than thirty (30) days and more than forty-five (45) days prior to the annual meeting, the Secretary of the Corporation shall cause to be printed and published an annual report and financial statement. The Secretary shall transmit at least one (1) copy of the annual report and financial statement to each Director not less than twenty-one (21) days prior to the annual meeting.

ARTICLE IX EXECUTIVE DIRECTOR

Section 1. Day-to-Day Management. The Board of Directors may appoint or hire an Executive Director to be primarily responsible for the day-to-day operations of the Corporation.

Section 2. Record Keeping. The Executive Director shall be made primarily responsible for keeping current and accurate records for the operations of the Corporation.

Section 3. Board Member. The Executive Director shall be an ex-official member of the Board and shall be an official Board of Directors without voting rights. The Executive Director shall be an unofficial member of all committees.

Section 4. Term. The Executive Director shall serve until she/he resigns or is removed by a majority vote of the Board of Directors.

Section 5. Employees. The Executive director shall be solely responsible for hiring, firing and supervising of employees of the Corporation. The Executive Director may fill only positions approved by the Board of Directors.

Section 6. Performance Review. The Executive Director shall be subject to performance reviews by the Board of directors at least every six months in the first year of employment and at least once per year thereafter.

**ARTICLE X
LEGAL COUNSEL**

The Board of Directors shall appoint legal counsel. All legal matters shall be promptly referred by the Board of Directors to counsel for opinion and advice. No director may also serve as legal counsel.

**ARTICLE XI
FINANCIAL AUDIT**

The books of the Corporation shall be audited annually by a certified public accountant appointed by the Board of Directors. No director may also serve as auditor. The auditor report shall be filed with the records of the Corporation and the auditor shall meet with the Board of Directors to present his/her finding and recommendations.

**ARTICLE XII
DISSOLUTION**

Upon the dissolution of the Corporation, the Board shall, after paying or making provision for the payment of all liabilities of the Corporation, distribute any remaining assets of the Corporation exclusively for charitable or educational purpose to such "qualified" organization or organizations as the Board of Directors shall determine. An organization shall be deemed to be a "qualified" organization if at the time of the distribution of such assets it is organized and operated exclusively for the purpose described in Section 17 (c)(2)(B) of the Internal Revenue Code and is described in Section 509 (a)(91), (2) or (3) of the Code.

**ARTICLE XIII
NO PRIVATE INUREMENT PROVISION**

No part of the net income or net assets of the corporation shall inure to the benefit of, or be distributable to, its directors, officers, members or other private persons. However, the corporation is authorized to pay reasonable compensation for services actually rendered and to make payments and distributions in furtherance of its tax-exempt purposes.

**ARTICLE XIV
INDEMNIFICATION OF ADVISORS**

The Board, officers, employees, and advisors of the Corporation shall not, in their capacity as Directors, officers, employees and advisors, be liable for the obligations of the Corporation. The Corporation shall indemnify and hold harmless each Director for any and all liability which may be imposed upon him/her as a Director of the Corporation, provided, however that this right of indemnify any Director for the commission of any unlawful act. The Corporation may purchase such "Directors and Officers" liability and corporate reimbursement insurance as the Board may deem appropriate to cover the Corporation's obligations and prerogatives.

**ARTICLE XV
BOOK AND RECORDS**

The Corporation shall keep correct and complete books and records of accounts and shall keep minutes of the proceedings of its members, Board of Directors, and committees having any of the authority of the Board of Directors, and shall keep a record of the Corporation may be inspected by any member, or his/her agent of attorney for any proper purpose at any reasonable time where such inspection does not infringe upon the rights of clients of the Corporation.

**ARTICLE XVI
FISCAL YEAR**

The fiscal year shall be the calendar year.

**ARTICLE XVII
SEVERABILITY**

If any part of these By-Laws shall be found to be invalid or ineffective, the validity and the effectiveness of the remaining provisions shall not be affected.

**ARTICLE XVIII
AMENDMENTS**

These By-Laws may be amended or repealed by two-thirds vote of the whole Board.

ARTICLE XIX

BOARD MEMBERS AND SIGNATURES

Board Member Names and Signatures are located on following pages.

SIGNATURE PAGE OF INITIAL BOARD OF DIRECTORS

Warren Roberts

DATE: 4/14/13

WARREN ROBERTS, President:
2017 Old Hearne Road
Bryan, Texas 77803

Lisa Mitchell

DATE: 4/14-13

Lisa Mitchell, Development Director
7301 Old Jones Road
College Station, Texas 77845

Tom Johnson

DATE: 9/14/13

Tom Johnson, Board Member
2326 Yellowstone Dr.
Bryan, Texas 77803

Angela Marks

DATE: 4/16/13

Angela Marks, Secretary
2406 Blanco Dr. Apt B.
College Station, Texas 77845

Toni Smith

DATE: 4/14/13

Toni Smith, Treasurer
2311 Bristol
Bryan, Texas 77802

I certify the above to be true and give witness by my signature that I Angela Marks
at 2002 Highway 21 East, Bryan, Texas 77806 am the current and/or acting Secretary of No Limits IEDC
which is located at 2002 Highway 21 East, Bryan, Texas 77806.
PH: (979) 778-7680; FAX: (979) 778-1388

Signed the 14th day of APRIL, 2013

President: Warren Roberts

Signature: Warren Roberts

Address: 2017 Old Hearne Road, Bryan, Texas 77803

PH: (979) 778-6063; FX: (979) 778-1388

Email: jrobertsb2@msn.com



**TEXAS DEPARTMENT OF
HOUSING & COMMUNITY AFFAIRS**
Building Homes. Strengthening Communities.

TAB 42

**Development Team
Members**

Development Team Members

The requested information on all known Development Team members must be provided. In addition to the categories listed below, the "Other" category should be used to list all known Development Team members that are included in the "Development Cost Schedule." If the team member that will be utilized is not yet known, indicate "TBD." If it is anticipated that the Development Team category will not be utilized, indicate "N/A."

** If there is a direct or indirect, financial, or other interest with Applicant or other team members, provide an attachment behind this form in the Application that explains the relationship(s).*

Developer:

Arlinda Gradens, LTD	Rick Sims	(318) 349-1588
	Contact Name	Phone
rrsims90@aol.com	TBD	n/a
Email	Proposed Fee	Tax ID Number (TIN)
Certified Texas HUB?	<input type="checkbox"/> No	
This is a direct or indirect, financial, or other interest with Applicant or other team members*		
<input type="checkbox"/> Yes		

Housing General Contractor:

SDC Construction, LLC	Adolphus Oji	(214) 342-1400
	Contact Name	Phone
adolphus@sdcus.com	TBD	20-7805054
Email	Proposed Fee	Tax ID Number (TIN)
Certified Texas HUB?	<input type="checkbox"/> No	
This is a direct or indirect, financial, or other interest with Applicant or other team members*		
<input type="checkbox"/> No		

Infrastructure General Contractor:

SDC Construction, LLC	Adolphus Oji	(214) 342-1400
	Contact Name	Phone
adolphus@sdcus.com	TBD	
Email	Proposed Fee	Tax ID Number (TIN)
Certified Texas HUB?	<input type="checkbox"/> No	
This is a direct or indirect, financial, or other interest with Applicant or other team members*		
<input type="checkbox"/> No		

Cost Estimator:

	Contact Name	Phone
	TBD	
Email	Proposed Fee	Tax ID Number (TIN)
Certified Texas HUB?	<input type="checkbox"/>	
This is a direct or indirect, financial, or other interest with Applicant or other team members*		
<input type="checkbox"/>		

Architect:

Kanyinda, LLC	Dixon Lubula	(682) 551-6960
	Contact Name	Phone
dixon.kanyinda@live.com	TBD	
Email	Proposed Fee	Tax ID Number (TIN)
Certified Texas HUB?	<input type="checkbox"/> No	
This is a direct or indirect, financial, or other interest with Applicant or other team members*		
<input type="checkbox"/> No		

Engineer:

FIF Engineering	Bijay Aryal, P.E.	(832) 341-9726
	Contact Name	Phone
bijayaryal@gmail.com	TBD	
Email	Proposed Fee	Tax ID Number (TIN)
Certified Texas HUB?	<input type="checkbox"/> No	
This is a direct or indirect, financial, or other interest with Applicant or other team members*		<input type="checkbox"/> No

Civil Engineer:

FIF Engineering	Bijay Aryal, P.E.	(832) 341-9726
	Contact Name	Phone
bijayaryal@gmail.com	TBD	
Email	Proposed Fee	Tax ID Number (TIN)
Certified Texas HUB?	<input type="checkbox"/> No	
This is a direct or indirect, financial, or other interest with Applicant or other team members*		<input type="checkbox"/> No

Market Analyst:

Gibson Consulting, LLC & GIBCO	Cynthia Gibson Bullard	
	Contact Name	Phone
ford@fgibsonconsulting.com	TBD	
Email	Proposed Fee	Tax ID Number (TIN)
Certified Texas HUB?	<input type="checkbox"/> No	
This is a direct or indirect, financial, or other interest with Applicant or other team members*		<input type="checkbox"/> No

Appraiser:

	Contact Name	Phone
Email	Proposed Fee	Tax ID Number (TIN)
Certified Texas HUB?	<input type="checkbox"/>	
This is a direct or indirect, financial, or other interest with Applicant or other team members*		<input type="checkbox"/>

Attorney:

	Contact Name	Phone
Email	Proposed Fee	Tax ID Number (TIN)
Certified Texas HUB?	<input type="checkbox"/>	
This is a direct or indirect, financial, or other interest with Applicant or other team members*		<input type="checkbox"/>

Accountant:

	Contact Name	Phone
Email	Proposed Fee	Tax ID Number (TIN)
Certified Texas HUB?	<input type="checkbox"/>	
This is a direct or indirect, financial, or other interest with Applicant or other team members*		<input type="checkbox"/>

Property Manager:

Sphinx Residential. LLC	Nedra Nortey	(214) 342-1400
	Contact Name	Phone
nedra@sdcus.com	TBD	45-1965665
Email	Proposed Fee	Tax ID Number (TIN)
Certified Texas HUB?	<input type="checkbox"/> No	
This is a direct or indirect, financial, or other interest with Applicant or other team members*		<input type="checkbox"/> No

Originator of Underwriter:

Rockhall Funding	Frank Martinez	(469) 730-4159
	Contact Name	Phone
fmartinez@rockhallfunding.com		
Email	Proposed Fee	Tax ID Number (TIN)
Certified Texas HUB?	<input type="checkbox"/> No	
This is a direct or indirect, financial, or other interest with Applicant or other team members*		<input type="checkbox"/> No

Bond Issuer:

	Contact Name	Phone
Email	Proposed Fee	Tax ID Number (TIN)
Certified Texas HUB?	<input type="checkbox"/>	
This is a direct or indirect, financial, or other interest with Applicant or other team members*		<input type="checkbox"/>

Syndicator:

	Contact Name	Phone
Email	Proposed Fee	Tax ID Number (TIN)
Certified Texas HUB?	<input type="checkbox"/>	
This is a direct or indirect, financial, or other interest with Applicant or other team members*		<input type="checkbox"/>

Supportive Services Provider:

	Contact Name	Phone
Email	Proposed Fee	Tax ID Number (TIN)
Certified Texas HUB?	<input type="checkbox"/>	
This is a direct or indirect, financial, or other interest with Applicant or other team members*		<input type="checkbox"/>

Supportive Services Provider:

	Contact Name	Phone
Email	Proposed Fee	Tax ID Number (TIN)
Certified Texas HUB?	<input type="checkbox"/>	
This is a direct or indirect, financial, or other interest with Applicant or other team members*		<input type="checkbox"/>

Title Company

Contact Name		Phone
Email	Proposed Fee	Tax ID Number (TIN)
Certified Texas HUB?		
This is a direct or indirect, financial, or other interest with Applicant or other team members*		

Application Consultant:

Vanguard Consultants Inc		
Vanessa Hardy		(972) 832-8489
Contact Name		Phone
vanguardconsultantsinc@gmail.com		
Email	Proposed Fee	Tax ID Number (TIN)
Certified Texas HUB?	No	
This is a direct or indirect, financial, or other interest with Applicant or other team members*		

ESA Provider:

Reed Engineering Group		
Xiaohong Wang		(214) 350-5600
Contact Name		Phone
xwang@reed-engineering.com		
Email	Proposed Fee	Tax ID Number (TIN)
Certified Texas HUB?		
This is a direct or indirect, financial, or other interest with Applicant or other team members*		

PCA Provider:

Contact Name		Phone
Email	Proposed Fee	Tax ID Number (TIN)
Certified Texas HUB?		
This is a direct or indirect, financial, or other interest with Applicant or other team members*		

Other:

Contact Name		Phone
Email	Proposed Fee	Tax ID Number (TIN)
Certified Texas HUB?		
This is a direct or indirect, financial, or other interest with Applicant or other team members*		

Other:

Contact Name		Phone
Email	Proposed Fee	Tax ID Number (TIN)
Certified Texas HUB?		
This is a direct or indirect, financial, or other interest with Applicant or other team members*		



**TEXAS DEPARTMENT OF
HOUSING & COMMUNITY AFFAIRS**
Building Homes. Strengthening Communities.

TAB 43

Architect Certification

Architect Certification Form

x

The Architect Certification is included behind this tab.

The form for the certification will be posted to the Department's website at
<http://www.tdhca.state.tx.us/multifamily/apply-for-funds.htm>.

The form for the certification will be posted to the Department's website at
<http://www.tdhca.state.tx.us/multifamily/apply-for-funds.htm>.

NOTE: The certification requires a separate statement be submitted that describes how the accessibility requirements for the physically accessible /hearing and visual impaired Units will be met, along with related parking requirements.

Be sure this statement is attached to this certification.

Architect Certification

I (We) certify that the Development will be designed and built to meet the accessibility requirements of the Federal Fair Housing Act as implemented by HUD at 24 C.F.R. Part 100 and the Fair Housing Act Design Manual, Titles II and III of the Americans with Disabilities Act (42 U.S.C. Sections 12131-12189) as implemented by the Department of Justice regulations at 28 C.F.R. Parts 35 and 36, and the Department's Accessibility rules in 10 TAC Chapter 1, Subchapter B, in effect at the time of certification.

I (we) certify that all materials submitted to the Department by the Architect or Applicant constitute records of the Department subject to Chapter 552, Tex. Gov't Code, and the Texas Public Information Act.

I (We) certify that in accordance with Section 504 of the Rehabilitation Act of 1973 and implemented at 24 C.F.R. Part 8, if the Development includes the New Construction or substantial rehabilitation of multifamily units (4 or more units per building), at least five percent (5%) of all dwelling units will be designed and built to be accessible for persons with mobility impairments. A unit that is on an accessible route and is adaptable and otherwise compliant with the 2010 ADA Standards with the exceptions listed in "Nondiscrimination on the Basis of Disability in Federally Assisted Programs and Activities" (Federal Register 79 FR 29671) meets this requirement. In addition, at least two percent (2%) of all dwelling units will be designed and built to be accessible for persons with hearing or vision impairments.

I (We) have attached a statement describing how the requirements Section 504 of the Rehabilitation Act of 1973 and implemented at 24 C.F.R. Part 8 will be met as described in 10 TAC Chapter 1, Subchapter B. At a minimum, the statement will include (1) The total number of Units (2) Number and description of Unit types, the number of Units of each Type, (3) Number of Units of each Type that will meet the accessibility requirements, and (4) a description of how the accessibility requirements relating to Unit distribution will be met.

I (We) certify that if the Development includes the New Construction or Rehabilitation of single family units (1 to 3 units per building), every unit will be designed and built to meet the accessibility requirements of Tex. Gov't Code §2306.514, as it may be amended from time to time.

I (We) have attached a statement describing how, regardless of building type, all Units accessed by the ground floor or by elevator ("affected units") meet the requirements at 10 TAC §10.101(b)(8)(B).

I(We) certify that all accessible Units under 10 TAC Chapter 1, Subchapter B, and all affected Units meeting the requirements under 10 TAC 10.101(b)(8)(B) will be dispersed throughout the Development.

2018 Architect Certification

If the Applicant is applying for HOME funds and the Development consists of New Construction, I (We) further certify that the Development meets the Construction Site Standards in 24 C.F.R §983.57(e)(1).

This certification meets the requirement that the Applicant provide a certification from the Development engineer or an accredited architect. A similar certification will also be required after the Development is completed from an inspector, architect, or accessibility specialist.

By: *Kanyinda*
Signature

2/27/2018
Date

LUBULA K. KANYINDA
Printed Name

N/A
License Number and State

N/A
Firm Name (If applicable)

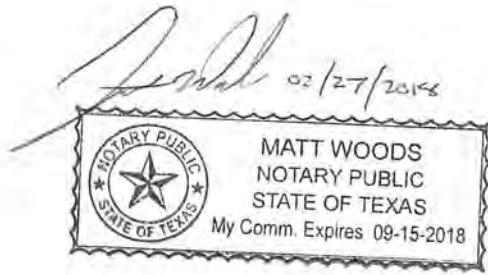



**TEXAS DEPARTMENT OF
HOUSING & COMMUNITY AFFAIRS**
Building Homes. Strengthening Communities.

TAB 44

Experience Certificate

Evidence of Experience Must be Provided Behind this Tab

Pursuant to §10.204(6) of the Uniform Multifamily Rules, a Principal of the Developer, Development Owner, or General Partner must establish that they have experience in the development of 150 units or more.

Evidence of experience behind this tab includes:



- An Experience certificate issued by the Department under the 2014-2018 Uniform Multifamily Rules.
- An Application for experience and supporting documentation in accordance with §10.204(6)(A)(i) through (ix)
- Evidence from the Department that the application for experience was received and is being processed by the Department.

Alternatively, pursuant to §13.5(d)(1) of the Multifamily Direct Loan Rule, Applicants requesting MFDL as the only source of Department funds may meet the Experience Requirement by providing evidence of the successful development and operation for at least 5 years of at least twice as many affordability restricted units as requested in the Application.

- Documentation provided behind this tab meets the alternative Experience Requirement in §13.5(d)(1).

DUNS Number and System for Award Management (SAM.gov) registration (Direct Loan Applications Only)

The Office of Management and Budget (OMB) requires grant applicants to provide a Dunn and Bradstreet (D&B) Data Universal Numbering System (DUNS) number when applying for Federal grants, including Direct Loan funds, on or after October 1, 2003. The DUNS number will supplement other identifiers required by statute or regulation, such as tax identification numbers. To apply for a DUNS number applicants can go to the Dunn & Bradstreet website:

<http://fedgov.dnb.com/webform>

Once applicants have obtained a DUNS number, they must register with the SAM database:

<https://sam.gov/portal/public/SAM>

Applicants may provide this information with the Application or upon award.



- Evidence of SAM.gov registration for the applicant entity is attached behind this tab.

Davis Bacon Labor Standards (Section 811 PRA Program and Direct Loan Applications)

24 CFR §92.354, Davis-Bacon Act (40 U.S.C. §§276(a)-276(a)(5), the Davis-Bacon Related Acts, the Contract Work Hours and Safety Standards Act, and the Copeland (Anti-Kickback) Act (40 U.S.C. §276(c)) apply to developments being assisted with Direct Loan funds if (Select all that apply):

- Twelve (12) or more Direct Loan or Section 811 PRA-assisted units will be rehabilitated or constructed under one construction contract.

The Section 811 PRA units and Direct Loan Units **are not cumulative**. For example, if a proposed development has ten Section 811 PRA units and ten Direct Loan-assisted units, Davis Bacon would not be triggered.

- Community Development Block Grant (CDBG) funds are being used to support the Development, which requires a lower number of units (8) be used as a threshold.

Applicants electing to participate in the Section 811 PRA Program either by committing an Existing Development to the Section 811 PRA Program or by committing a Proposed Development in this Application are encouraged to review §PRA.213 Davis Bacon Labor Standards in the Section 811 Program Guidelines, found on the TDHCA webpage at

<http://www.tdhca.state.tx.us/section-811-pra/resource-documents.htm>

Existing Developments where construction is fully complete before an application for a Proposed Development is submitted to the Department to receive assistance under the 811 PRA program are not subject to Davis-Bacon or Contract Work Hours and Safety Standards Act requirements.

Affirmative Marketing Plan (Direct Loan Applications Only)

Complete and submit HUD's Affirmative Marketing Plan form (Form 935.2 or successors). This form may be found on the Department's website at

<http://www.tdhca.state.tx.us/home-division/mf-home/index.htm>

The Affirmative Marketing Plan must comply with the Affirmative Marketing requirements in the Compliance Rules.

HUD approval is not necessary unless the property receives project-based Section 8 assistance.



Affirmative Fair Housing Marketing (AFHM) Plan - Single Family Housing

U.S. Department of Housing and Urban Development
Office of Fair Housing and Equal Opportunity

OMB Approval No. 2529-0013
(exp. 12/31/2016)

1a. Applicant's Name, Address (including City, State & Zip code) & Phone Number Arlinda Gardens, LTD 420 Walnut St. Minden, LA 318-349-1588	1c. Development Number	1d. Number of Units 30
	1e. Price Range From \$ 394.00 To \$ 957.00	1f. Type of Housing <input checked="" type="checkbox"/> Development <input type="checkbox"/> Scattered Site
	1g. Approximate Starting Dates (mm/dd/yyyy) Advertising 02/01/2019 Occupancy 05/30/2019	

1b. Development's Name, Location (including City, State and Zip code) Arlinda Gardens Supportive Housing 2002 Hwy 21 E. Bryan, TX 76086	1h. Housing Market Area College Station-Bryan, TX	1i. Census Tract 48041000300
	1j. Sales Agent's Name & Address (including City, State and Zip Code) n/a	

2. Type of Affirmative Marketing Area (check all that apply) <input checked="" type="checkbox"/> White (non-minority) Area <input type="checkbox"/> Minority Area <input type="checkbox"/> Mixed Area (with _____ % minority residents)	3. Direction of Marketing Activity (Indicate which group(s) in the housing market area are least likely to apply for the housing because of its location and other factors without special outreach efforts) <input type="checkbox"/> White <input type="checkbox"/> American Indian or Alaskan Native <input checked="" type="checkbox"/> Asian <input type="checkbox"/> Black or African American <input type="checkbox"/> Native Hawaiian or Other Pacific Islander <input checked="" type="checkbox"/> Hispanic or Latino <input checked="" type="checkbox"/> Persons with Disabilities <input type="checkbox"/> Families with Children <input type="checkbox"/> Other _____ Specify _____ (e.g. specific ethnic group, religion, etc.)
---	--

4a. **Marketing Program: Commercial Media** (Check the type of media to be used to advertise the availability of this housing)

Newspapers/Publications
 Radio
 TV
 Billboards
 Other (specify) Flyers

Name of Newspaper, Radio or TV Station	Group Identification of Readers/Audience	Size/Duration of Advertising
n/a		

4b. **Marketing Program: Brochures, Signs, and HUD's Fair Housing Poster**

(1) Will brochures, letters, or handouts be used to advertise? Yes No If "Yes", attach a copy or submit when available.

(2) For development site sign, indicate sign size _____ x _____; Logo type size _____ x _____. Attach a photograph of sign or submit when available.

(3) HUD's Fair Housing Poster must be conspicuously displayed wherever sales/rentals and showings take place. Fair Housing Posters will be displayed in the Sales Office Real Estate Office Model Unit Other (specify) Club House

4c. **Marketing Program: Community Contacts.** To further inform the group(s) least likely to apply about the availability of the housing, the applicant agrees to establish and maintain contact with the groups/organizations listed below which are located in the housing market area. If more space is needed, attach an additional sheet. Notify HUD-Housing of any changes in this list. Attach a copy of correspondence to be mailed to these groups/organizations. (Provide all requested information.)

Name of Group/Organization	Group Identification	Approximate Date (mm/dd/yyyy)	Person Contacted (or to be Contacted)
The Hispanic Forum	Hispanic	02/01/2019	TBD
Texas A&M Chinese Student Association	Asian	02/01/2019	Christina Jiang
Beautiful Abilities	Persons w/ Disa	02/01/2019	TBD

Address & Phone Number	Method of Contact	Indicate the specific function the Group/Organization will undertake in implementing the marketing program
P.O. Box 4690 Bryan, Texas 77805	Postal Service	they will distribute information/flyers to their members
125 John J. Koldus Building College Station, TX 77843	Postal Service	they will distribute information/flyers to their members
4202 E. 29th St. Bryan, TX 77802	Postal Service	they will distribute information/flyers to their members

<p>5. Reserved</p>	<p>6. Experience and Staff Instructions (See instructions)</p> <p>6a. Staff has affirmative marketing experience. <input type="checkbox"/> No <input checked="" type="checkbox"/> Yes</p> <p>6b. On separate sheets, indicate training to be provided to staff on Federal, State and local fair housing laws and regulations, as well as this AFHM Plan. Attach a copy of the instructions to staff regarding fair housing.</p>
---------------------------	---

7. **Additional Considerations** Attach additional sheets as needed.

8. **Compliance with AFHM Plan Regulations:** By signing this form, the applicant agrees to ensure compliance with HUD's Affirmative Fair Housing Marketing Regulations (24 CFR 200.620).

Signature of person submitting this Plan & Date of Submission (mm/dd/yyyy)

Name (type or print)
Rick Sims

Title & Name of Company
Managing Member, Arlinda Gardens, LTD

For HUD-Office of Housing Use Only	For HUD-Office of Fair Housing and Equal Opportunity Use Only
Approved _____ Disapproved _____ (Check One)	
Signature & Date (mm/dd/yyyy)	Signature & Date (mm/dd/yyyy)
Name (type or print)	Name (type or print)
Title	Title

Public reporting burden for this collection of information is estimated to average 3 hours per response, including the time for reviewing instructions, searching existing data sources, gathering and maintaining the data needed, and completing and reviewing the collection of information. This agency may not collect this information, and you are not required to complete this form, unless it displays a currently valid Office of Management and Budget (OMB) control number.

In General: The Affirmative Fair Housing Marketing (AFHM) Plan is used to ensure that Federal Housing Administration (FHA)-insured single family housing developers are taking necessary steps to eliminate discriminatory practices and to overcome the effects of past discrimination involving Federally insured housing. No application for any housing development insured under the Department of Housing and Urban Development's (HUD) housing programs, shall be funded without a HUD-approved AFHM Plan (See the "Applicability" section in the instructions below.) Single family housing developers complete the AFHM Plan only during the application process and the AFHM Plan is in effect until after initial occupancy. The responses are required to obtain or retain benefits under the Fair Housing Act, Section 808(e)(5) & (6) and 24 CFR Part 200, Subpart M. The form contains no questions of a confidential nature.

Applicability: Single family developers should answer the following two questions to determine if they need to complete an AFHM Plan or if they should complete block 11 on Form HUD-92541, Builder's Certification of Plans, Specifications, & Site. (See HUD Mortgagee Letter 1995-18 dated April 28, 1995 and 2001-09 dated April 2, 2001 for further instructions).

Question 1. (Check if applicable)

- a. Did you sell five (5) or more houses in the last twelve (12) months with HUD mortgage insurance?
- b. Do you intend to sell five (5) or more houses within the next twelve (12) months with HUD mortgage insurance?

If you did **not** check 1a or 1b, you do **not** have to complete an AFHM Plan. You should complete block 11 on the HUD-92541.

If you checked 1a and/or 1b, you must go to Question 2.

Question 2. (Check if applicable)

- a. I am a signatory in good standing to a Voluntary Affirmative Marketing Agreement (VAMA).
- b. I have an AFHM Plan that HUD approved.
- c. I have contracted with a company that has an AFHM Plan or who is a signatory to a VAMA to market my houses.
- d. I certify that I will comply with the following: (a) Carry out an affirmative marketing program to attract all minority and majority groups to the housing for initial sale. Such a program shall typically involve publicizing to minority persons the availability of housing opportunities regardless of race, color, religion, sex, disability, familial status or national origin, through the type of media customarily utilized by the applicants; (b) Maintain a nondiscriminatory hiring policy in recruiting from both minority and majority groups; (c) Instruct all employees and agents in writing and orally of the policy of nondiscrimination and fair housing; (d) Conspicuously display the Fair Housing Poster in all Sales Offices, include the Equal Housing Opportunity logo, slogan and statement in all printed material used in connection with sales, and post in a prominent position at the project site a sign that displays the Equal Opportunity logo, slogan or statement, as listed in 24 CFR 200.620 and appendix to subpart M to part 200. I understand that I am obliged to develop and maintain records on these activities, and make them available to HUD upon request.

If you checked "a, b, c, or d" in Question 2, you do **not** have to complete an AFHM Plan. You should complete block 11 on the HUD-92541.

If you did **not** check “a, b, c or d” in Question 2, you must complete an AFHM Plan.

Each applicant is required to carry out an affirmative program to attract prospective buyers of all minority and non-minority groups in the housing market area regardless of their race, color, religion, sex, national origin, disability or familial status (24 CFR 200.620). Racial groups include White, Black or African American, American Indian or Alaska Native, Asian, Native Hawaiian or Other Pacific Islander. Other groups in the housing market area who may be subject to housing discrimination include, but are not limited to, Hispanic or Latino, persons with disabilities, families with children, or persons of different religious affiliations. The applicant shall describe in the AFHM Plan the proposed activities to be carried out during advance marketing, where applicable, and the initial sales period. The affirmative marketing program also should ensure that any group(s) of persons ordinarily **not** likely to apply for this housing without special outreach (See Part 3), know about the housing, feel welcome to apply and have the opportunity to buy.

INSTRUCTIONS

Send completed form to: your local HUD Office
Attention: Director, Office of Housing

Part 1-Applicant and Project Identification.

Blocks 1a thru 1f-Self-Explanatory. Block 1g-the applicant should specify the approximate date for starting the marketing activities and the anticipated date of initial occupancy. Block 1h-the applicant should indicate the housing market area, in which the housing will be located. Block 1i - the applicant may obtain census tract location information from local planning agencies, public libraries and other sources of census data. Block 1j the applicant should complete only if a Sales Agent (the agent can not be the applicant) is implementing the AFHM Plan.

Part 2-Type of Affirmative Marketing Area:

The AFHM Plan should indicate the approximate racial composition of the housing market area in which the housing will be located by checking one of the three choices. Single family scattered site builder should submit an AFHM Plan that reflects the approximate racial composition of each housing market area in which the housing will be located. For example, if a builder plans to construct units in both minority and non-minority housing market areas, a separate AFHM Plan shall be submitted for each housing market area.

Part 3-Direction of Marketing Activity. Indicate which group(s) the applicant believes are least likely to apply for this housing without special outreach. Consider factors such as price or rental of

housing, sponsorship of housing, racial/ethnic characteristics of housing market area in which housing will be located, disability, familial status, or religious affiliation of eligible population, public transportation routes, etc.

Part 4-Marketing Program. The applicant shall describe the marketing program to be used to attract all segments of the eligible population, especially those groups designated in Part 3 of this AFHM Plan present in the housing marketing area that are least likely to apply. The applicant shall state: the type of media to be used, the names of newspaper/call letters of radio or TV stations; the identity of the circulation or audience of the media identified in the AFHM Plan (e.g., White, Black or African American, American Indian or Alaska Native, Asian, Native Hawaiian or Other Pacific Islander, Hispanic or Latino, persons with disabilities, families with children, and religious affiliation), and the size or duration of newspaper advertising or length and frequency of broadcast advertising. Community contacts include individuals or organizations that are well known in the housing market area or the locality that can influence persons within groups considered least likely to apply. Such contacts may include, but need not be limited to: neighborhood, minority and women’s organizations, grass roots faith-based or other community based organizations, labor unions, employers, public and private agencies, disability advocates, schools and individuals who are connected with these organizations and/or are well-known in the community. Applicants should notify their local HUD–Office of Housing of any changes to the list in Part 4c of this AFHM Plan.

Part 5-Reserved

Part 6-Experience and Staff Instructions.

- 6a. The applicant should indicate whether he/she has had previous experience in marketing housing to group(s) identified as least likely to apply for the housing.
- 6b. Describe the instructions and training provided or to be provided to sales staff. This guidance to staff must include information regarding Federal, State and local fair housing laws and this AFHM Plan.

Copies of any written materials should be submitted with the AFHM Plan, if such materials are available.

Part 7-Additional Considerations. In this section describe other efforts not previously mentioned which are planned to attract persons least likely to apply for the housing.

Part 8-Compliance with AFHM Plan Regulation.

By signing, the applicant assumes full responsibility for implementing the AFHM Plan. HUD may monitor the implementation of this AFHM Plan at any time and request modification in its format or content, where deemed necessary.

Notice of Intent to Begin Marketing. No later than 90 days prior to the initiation of sales marketing activities, the applicant with an approved AFHM Plan shall submit notice of intent to begin marketing. The notification is required by the Affirmative Fair Housing Marketing Plan Compliance Regulations (24 CFR Part 108.15). It is submitted either orally or in writing to the Office of Housing in the appropriate HUD Office servicing the locality in which the proposed housing will be located.

OMB approval of the Affirmative Fair Housing Plan includes approval of this notification procedure as part of the AFHM Plan. The burden hours for such notification are included in the total designated for this AFHM Plan form.



**TEXAS DEPARTMENT OF
HOUSING & COMMUNITY AFFAIRS**
Building Homes. Strengthening Communities.

TAB 45

9% Applicant Credit Limit Documentation and Certification

Applicant Credit Limit Documentation and Certification (Competitive HTC Only)

Pursuant to §11.4(a) of the Qualified Allocation Plan, the Department shall not allocate more than \$3 million of Competitive Housing Tax Credits from the current Application Round to any Applicant, Developer, Affiliate or Guarantor (unless the Guarantor is also the General Contractor, and is not a Principal of the Applicant, Developer, or Affiliate of the Development Owner). All Applications must be identified herein to ensure that the Department is advised of all Applications, Applicants, Affiliates, Developers, General Partners or Guarantors involved to avoid any statutory violation of Texas Government Code, §2306.6711(b).

Instructions:

Complete Part I of this form. For each person or entity in Part I that answers "Yes" to Part I b., a Part II form must be submitted (i.e. if 4 persons/entities answer "Yes" to Part I b., then 4 separate Part II forms must be provided).

Part I. Applicant Credit Limit Documentation

a. Applicant, Developers, Affiliates, and Guarantors - List below all entities or Persons meeting the definition of Applicant, Affiliate, Developer or Guarantor.	b. Person/entity has at least one other application in the current Application Round.	
1.		
2.		
3.		
4.		
5.		
6.		
7.		
8.		
9.		
10.		
11.		
12.		
13.		
14.		
15.		
16.		
17.		
18.		
19.		
20.		
21.		
22.		
23.		
24.		
25.		
26.		
27.		
28.		
29.		
30.		

Individually, or as the General Partner(s) of officer(s) of the Applicant entity, I (we) certify that we are submitting behind this tab one signed Credit Limit Certification form for each person and/or entity that answered "Yes" to Part b. above.

By: _____ Date: _____ Its: _____
Signature of Applicant
Date

Part II. Credit Limit Certification

Instructions:

Each Person and/or Entity that answered "Yes" to Part 1 (b) must complete this form.

Name and role of Person or Entity completing this form: Should be the same as listed in Part I.

- Which is: the Applicant (Entity that generally manages or controls the "Applicant," i.e. General Partner, Managing Partner, etc.)
- a Special Limited Partner or Class B Limited Partner or equivalent of the Applicant
- a Developer for the Applicant for this specific Application
- an Affiliate to the Applicant
- a Guarantor on the Application

Pursuant to §11.4(a) of the Qualified Allocation Plan, the Department shall not allocate more than \$3 million of tax credits from the current Application Round to any Applicant, Developer, Affiliate or Guarantor. The undersigned represents to the Department that the following is a list of all developments for which the Applicant, the Developer, Affiliate, or Guarantor, has applied for an allocation of tax credit authority from the Department in the current Application Round.

Development Name:	Region:	City:	% Ownership:	% of Dev. Fee:

I acknowledge that Should be same as signer of Development Owner Certification. is authorized to terminate the Application in the event of a conflict with §11.4(a) of the Qualified Allocation Plan.

I hereby certify that the foregoing is a complete list of Developments with respect to which I am seeking a current allocation of tax credit authority from the Department. I certify that, if the Department makes a recommendation to the Board or issues a commitment which may cause Applications for which I am the Applicant, the Developer, Affiliate or Guarantor, to receive credits in excess of \$3 million, I will notify the Department in writing within three business days of the recommendation or issuance of the Commitment.

I acknowledge that if the Department determines that an Applicant, Developer, Affiliate or Guarantor, has received (in the aggregate) allocations in the current Application Round from the Department exceeding \$3 million, the Department must refuse to issue one or more Commitments or Carryover Allocations, or must terminate one or more Commitments or Carryover Allocations.

Under penalty of perjury, I certify that this information and these statements are true, complete, and accurate:

By: Should be the same as listed in Part I.

Signature of Applicant, Developer, Affiliate or Guarantor (as appropriate) *Printed Name* *Date*



**TEXAS DEPARTMENT OF
HOUSING & COMMUNITY AFFAIRS**

Building Homes. Strengthening Communities.

TAB 46

Community Input

Community Input Scoring Items

TDHCA#:

1. Local Government Support - §11.9(d)(1)

- Resolution(s) of either "no objection" or "support" is included behind this tab.**
** Note that resolutions are due March 1, 2018

2. Community Support from State Representative - §11.9(d)(5)

- Letter of either "support" or "opposition" is included behind this tab.**
** Note that letters are due March 1, 2018

3. Input from Community Organizations - §11.9(d)(6)

- Applicant has included one or more letters of support or opposition behind this tab.

List information for each of the letters below:

- A.
Name of Community Organization Support
 Opposition
Contact Name
- B.
Name of Community Organization Support
 Opposition
Contact Name
- C.
Name of Community Organization Support
 Opposition
Contact Name
- D.
Name of Community Organization Support
 Opposition
Contact Name
- E.
Name of Community Organization Support
 Opposition
Contact Name
- F.
Name of Community Organization Support
 Opposition
Contact Name



**TEXAS DEPARTMENT OF
HOUSING & COMMUNITY AFFAIRS**

Building Homes. Strengthening Communities.

TAB 47

Third Party Reports

Required Third Party Reports

Be advised that all third party reports will be posted on the Department's website along with the Application.

Complete the information below as applicable [§10.205].

1. Environmental Site Assessment (ESA) (All Multifamily Applications)

Prepared by: Reed Engineering Group

Date of Report: 2/23/2018

Report recommends further studies or establishes environmental hazards that currently exist on the Property or off-site with the potential to affect the Property.

If the above box is checked, a statement is provided behind this tab signed by the Development Owner, that certifies the Development Owner will comply with any and all recommendations made by the ESA preparer.

Development is funded by USDA and is not required to supply an ESA.

2. Environmental Clearance (Section 811 PRA and Direct Loan applications only)

All Applications selecting Points for Section 811 PRA Program participation under the Competitive Housing Tax Credit program or Direct Loans must review the Environmental Requirements and Environmental Assurance section of the Section 811 PRA Program Guidelines (§PRA.215) and provide adequate material to meet the tenets. A Phase I Environmental Site Assessment (ESA) will not satisfy the environmental clearance required for use of the Section 811 PRA Program.

All Applications for Direct Loans by the Department must complete an environmental clearance process in accordance with 24 CFR Parts 50 and 58 prior to engaging in choice limiting activities such as closing on land, loans, beginning demolition or construction activities, or entering into construction contracts. A Phase I Environmental Site Assessment (ESA) will not satisfy the environmental clearance required for use of Multifamily Direct Loan funds.

Application selected points for the Section 811 PRA Program and includes documentation for the project participating in the Section 811 PRA Program that the project meets the tenets of HUD environmental policy and the requirements of applicable statutes and authorities. 

Applicant has submitted an environmental packet to TDHCA and determination is pending.

Applicant has reviewed the Environmental Requirements and Environmental Assurance section of the Section 811 PRA Program Guidelines (§PRA.215) and understands that a determination must be received prior to signing the Rental Assistance Contract. 

MFDL Development has already received Environmental Clearance from HUD under 24 CFR Parts 50 or 58.

Documentation of HUD Environmental Clearance is included behind this tab.

Applicant has submitted an environmental packet to TDHCA and clearance is pending. 

Applicant has reviewed the environmental clearance materials available on the Department's website and understands that clearance must be received prior to closing on the loan.
<http://www.tdhca.state.tx.us/program-services/environmental/index.htm>

A Third Party will aid in the completion of the environmental clearance process. If checked, complete the following:

Name of Firm: _____

Contact Person: _____

Contact Telephone: _____

Email: _____

3. Primary Market Area Map

Primary Market Area (PMA) map with definition of PMA is included behind this tab.

Prepared by: Gibson Consulting, LLC & GIBCO Environmental, LLC

Date of Report: _____

4. Property Condition Assessment (PCA)

Prepared by: --Complete on Development Team (Tab 42)--

Date of Report: 12/22/2017

Multifamily Finance Division staff will place scanned copies of deficiency documents behind this tab in the application .pdf

Multifamily Finance Division staff will place scanned
copies of scoring notices behind this tab in the
application .pdf

Multifamily Finance Division staff will place documents related to Requests for Administrative Deficiencies behind this tab in the application .pdf

Real Estate Analysis Division staff will place scanned
copies of RFI documents behind this tab in the
application .pdf

Multifamily Finance Division staff will place scanned copies of appeal documents behind this tab in the application .pdf

Multifamily Finance Division staff will place scanned copies of public comment received behind this tab in the application .pdf

Multifamily Finance Division staff will place scanned copies of Commitment or Determination Notice documents behind this tab in the application .pdf

Multifamily Finance Division staff will place scanned copies of Direct Loan Program Award Letters behind this tab in the application .pdf

Multifamily Finance Division staff will place scanned copies of Carryover Allocation Agreement documents behind this tab in the application .pdf

(d) Criteria promoting community support and engagem

(1) Local Government Support. (§2306.6710(b)(1)(B))

~~seventeen (17) points for a resolution or resolutions~~

Conflict of Interest

CFR §92.356

(A) Within a municipality, the Application will receive:

(i) seventeen (17) points for a resolution from the Governing Body of that municipality expressly setting forth that the municipality supports the Application or Development; or

(ii) fourteen (14) points for a resolution from the Governing Body of that municipality expressly setting forth that the municipality has no objection to the Application or Development.

2017 CHDO Certification

NO LIMITS INTERNATIONAL ECONOMIC DEVELOPMENT CORPORATION May 24, 2007
Name of CHDO Date of Formation

On behalf of the Community Housing Development Organization ("CHDO") Applicant (hereinafter "Applicant"), I hereby certify that Applicant is familiar with the provisions of the federal HOME Final Rule, as published in 24 CFR §92, the state Uniform Multiple Housing Rules, as published in 10 TAC Chapters 1, 2, and 10, 13, or 20 and 23 as applicable, and other related administrative rules, regulations and court rulings issued by the Federal government or state of Texas with respect to CHDOs and the HOME Investment Partnerships Program and will comply with such rules during the application process and in the event of award, for the duration of the development process and/or affordability period.

- I hereby certify that the Applicant will comply with the applicable requirements of the conflict of interest provisions state. CFR §92.356 and 24 CFR §200.12.
- I hereby certify that the Applicant meets the requirements of the CHDO definition in 24 CFR §92.2.
- I hereby certify that no person or entity that would benefit from the award of HOME funds has provided a source of funds defined in 24 CFR §92.220 or has satisfied the Applicant's obligation pursuant to 10 TAC §10.307(a)(5) or made prom connection therewith.
- I hereby certify any funds granted to the CHDO as CHDO Operating Expenses will be expended in compliance with 24 CFR §92.208, and 24 CFR §§200.32 and 200.33.
- I hereby certify the CHDO will create and follow a tenant participation plan as required in 24 CFR §92.303 for development activities.
- I hereby certify that all statements I have provided in this application and in the Sections herein are true; that I am authorized to sign this application, and to make these statements, on behalf of the applicant organization; and that the organization understands that misrepresentation of any facts which lead to the improper allocation and expenditure of public funds result in legal action against the organization for retrieval of any such funds and appropriate penalties.
- I agree the Department may, at its discretion, request additional information and/or documentation in its evaluation Application.
- I hereby certify that (I) we, as a CHDO, will qualify as the owner of rental housing as defined in 24 CFR §92.300(a)(2)-(5) or will qualify as the owner and developer of housing for homeownership as defined in 24 CFR §92.300(a)(6).



 Signature of Authorized CHDO Representative
 Rick Sims

 Printed Name of Individual

Executive Director

 Title
 2/27/2017

 Date

Office of the Secretary, HUD

§ 92.356

(c) The prevailing wage provisions of paragraph (a) of this section do not apply to members of an eligible family who provide labor in exchange for acquisition of a property for homeownership or provide labor in lieu of, or as a supplement to, rent payments.

§ 92.355 Lead-based paint.

Housing assisted with HOME funds is subject to the Lead-Based Paint Poisoning Prevention Act (42 U.S.C. 4821-4846), the Residential Lead-Based Paint Hazard Reduction Act of 1992 (42 U.S.C. 4851-4856), and implementing regulations at part 35, subparts A, B, J, K, M and R of this title.

[64 FR 50224, Sept. 15, 1999]

§ 92.356 Conflict of interest.

(a) In the procurement of property and services by participating jurisdictions, State recipients, and subrecipients, the conflict of interest provisions in 24 CFR 85.36 and 24 CFR 84.42, respectively, apply. In all cases not governed by 24 CFR 85.36 and 24 CFR 84.42, the provisions of this section apply.

(b) No persons described in paragraph (c) of this section who exercise or have exercised any functions or responsibilities with respect to activities assisted with HOME funds or who are in a position to participate in a decisionmaking process or gain inside information with regard to these activities, may obtain a financial interest or benefit from a HOME-assisted activity, or have an interest in any contract, subcontract or agreement with respect thereto, or the proceeds thereunder, either for themselves or those with whom they have family or business ties, during their tenure or for one year thereafter.

(c) The conflict of interest provisions of paragraph (b) of this section apply to any person who is an employee, agent, consultant, officer, or elected official or appointed official of the participating jurisdiction, State recipient, or subrecipient which are receiving HOME funds.

(d) Upon the written request of the participating jurisdiction, HUD may grant an exception to the provisions of para-

graph (b) of this section on a case-by-case basis when it determines that the exception will serve to further the purposes of the HOME Investment Partnerships Program and the effective and efficient administration of the participating jurisdiction's program or project. An exception may be considered only after the participating jurisdiction has provided the following:

(1) A disclosure of the nature of the conflict, accompanied by an assurance that there has been public disclosure of the conflict and a description of how the public disclosure was made; and

(2) An opinion of the participating jurisdiction's or State recipient's attorney that the interest for which the exception is sought would not violate State or local law.

(e)

In determining whether to grant a requested exception after the participating jurisdiction has satisfactorily met the requirements of paragraph (d) of this section, HUD will consider the cumulative effect of the following factors, where applicable:

(1) Whether the exception would provide a significant cost benefit or an essential degree of expertise to the program or project which would otherwise not be available;

(2) Whether the person affected is a member of a group or class of low-income persons intended to be the beneficiaries of the assisted activity, and the exception will permit such person to receive generally the same interests or benefits as are being made available or provided to the group or class;

(3) Whether the affected person has withdrawn from his or her functions or responsibilities, or the decisionmaking process with respect to the specific assisted activity in question;

(4) Whether the interest or benefit was present before the affected person was in a position as described in paragraph (c) of this section;

(5) Whether undue hardship will result either to the participating jurisdiction or the person affected when weighed against the public interest served by avoiding the prohibited conflict; and

(6) Any other relevant considerations.

§ 92.357

(f) (1) No owner, developer or sponsor of a project assisted with HOME funds (or officer, employee, agent, elected or appointed official or consultant of the owner, developer or sponsor) whether private, for-profit or non-profit (including a community housing development organization (CHDO) when acting as an owner, developer or sponsor) may occupy a HOME-assisted affordable housing unit in a project. This provision does not apply to an individual who receives HOME funds to acquire or rehabilitate his or her principal residence or to an employee or agent of the owner or developer of a rental housing project who occupies a housing unit as the project manager or maintenance worker.

(2) Upon written request of a housing owner or developer, the participating jurisdiction (or State recipient, if authorized by the State participating jurisdiction) may grant an exception to the provisions of paragraph (f)(1) of this section on a case-by-case basis when it determines that the exception will serve to further the purposes of the HOME program and the effective and efficient administration of the owner's or developer's HOME-assisted project. In determining whether to grant a requested exception, the participating jurisdiction shall consider the following factors:

(i) Whether the person receiving the benefit is a member of a group or class of low-income persons intended to be the beneficiaries of the assisted housing, and the exception will permit such person to receive generally the same interests or benefits as are being made available or provided to the group or class;

(ii) Whether the person has withdrawn from his or her functions or responsibilities, or the decisionmaking process with respect to the specific assisted housing in question;

(iii) Whether the tenant protection requirements of § 92.253 are being observed;

(iv) Whether the affirmative marketing requirements of § 92.351 are being observed and followed; and

(v) Any other factor relevant to the participating jurisdiction's determina-

24 CFR Subtitle A (4-1-05 Edition)

tion, including the timing of the requested exception.

[61 FR 48750, Sept. 16, 1996, as amended at 62 FR 28930, May 28, 1997]

§ 92.357 Executive Order 12372.

(a) Executive Order 12372, as amended by Executive Order 12416 (3 CFR, 1982 Comp., p. 197 and 3 CFR, 1983 Comp., p. 186) (Intergovernmental Review of Federal Programs) and HUD's implementing regulations at 24 CFR part 52, allow each State to establish its own process for review and comment on proposed Federal financial assistance programs.

(b) Executive Order 12372 applies to applications submitted with respect to HOME funds being competitively reallocated under subpart J of this part to units of general local government.

§ 92.358 Consultant activities.

No person providing consultant services in an employer-employee type relationship shall receive more than a reasonable rate of compensation for personal services paid with HOME funds. In no event, however, shall such compensation exceed the limits in effect under the provisions of any applicable statute (e.g., annual HUD appropriations acts which have set the limit at the equivalent of the daily rate paid for Level IV of the Executive Schedule, see the Departments of Veterans Affairs and Housing and Urban Development, and Independent Agencies Appropriations Act, 1997, Pub. L. 104-204 (September 26, 1996)). Such services shall be evidenced by written agreements between the parties which detail the responsibilities, standards, and compensation. Consultant services provided under an independent contractor relationship are not subject to the compensation limitation of Level IV of the Executive Schedule.

[62 FR 28930, May 28, 1997]

Subpart I—Technical Assistance

§ 92.400 Coordinated Federal support for housing strategies.

(a) HUD will provide assistance in accordance with Subtitle C of the Act.

2017 Affidavit of CHDO Participation

I certify that I am an authorized representative of the below named CHDO, and that the CHDO will own the rental housing that it develops in fee simple absolute or have a long term ground lease for a period at least equal to the federal affordability period. If the CHDO will not be developing the rental housing, the CHDO will hire and oversee the developer, or at a minimum, hire or contract with an experienced project manager to oversee all aspects of development, while still maintaining ownership of the rental housing in fee simple absolute or having a long term ground lease for a period at least equal to the federal affordability period. If the CHDO will not be owning or developing the rental housing directly, the CHDO will sponsor a limited partnership or limited liability company, of which the CHDO or its subsidiary will be the sole general partner or sole managing member that wholly owns the limited partnership or limited liability company, to own or develop the rental housing. If the limited partnership or limited liability company agreement permits the CHDO to be removed as general partner or sole managing member, the agreement must provide that the removal must be for cause and that the CHDO must be replaced with another CHDO.

I certify that the above statement is true and correct. I understand that any misstatement or falsification of information shall be grounds for denial or revocation of certification for CHDO status.

By: 

Signature of Authorized Representative
Rick Sims

Printed Name
Executive Director

Title

2/22/2017

Date

I, the undersigned, a Notary Public in and for said County and State, do hereby certify that signed Rick Sims who signed the foregoing statement, and who is known to be one in the same, has acknowledged before me on this date, that being informed of the contents of this statement, executed the same voluntarily on the date same foregoing statement bears.

GIVEN UNDER MY HAND AND SEAL OF OFFICE this 22 day of February 20 17

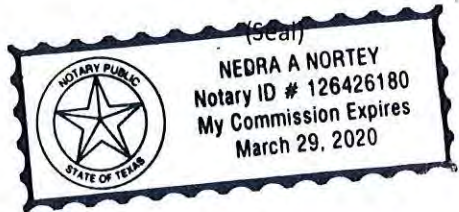

Nedra Northey

Notary Public Signature
Texas

Notary Public, State of
Dallas

County of
03.29.2020

My commission expires

2017 Affidavit of Low-Income Board Representation - Authorized Representative

I hereby certify that the individuals identified in the following affidavits are residents of a low income neighborhood, other low-income community resident, or elected representative of a low income neighborhood organization and is an active member of the Board of Directors of No Limit International Economic Development Corporation, a private nonprofit corporation.

"Low income" is defined as households whose annual incomes do not exceed 80% of the median income for the area, as determined by HUD with adjustments for smaller and larger families.

I certify that the above statement is true and correct. I understand that any misstatement or falsification of information shall be grounds for denial or revocation of certification for CHDO status.

By: 
Signature of Authorized Representative
Rick Sims
Printed Name
Executive Director
Title
2/22/2017
Date

I, the undersigned, a Notary Public in and for said County and State, do hereby certify that Rick Sims who signed the foregoing statement, and who is known to be one in the same, has acknowledged before me on this date, that being informed of the contents of this statement, executed the same voluntarily on the date same foregoing statement bears.

GIVEN UNDER MY HAND AND SEAL OF OFFICE this 22 day of February 20 17

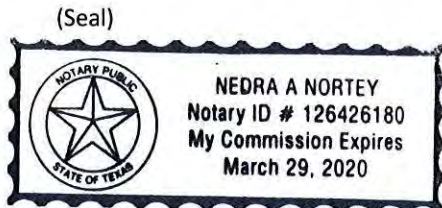

Notary Public Signature
Texas
Notary Public, State of
Dallas
County of
03/29/2020
My comission expires

2017 Affidavit of Standards for Financial Management Systems

Date: 2/22/2017

Affiant: Rick Sims

Recipient: No Limit International Economic Development
(Exact Legal Name of Organization)

Affiant on oath swears that the following statements are true and are within the personal knowledge of Affiant:

1. Affiant is the President AND/OR Chief Financial Officer of the Applicant and is authorized to make this affidavit on behalf of Applicant.
2. Applicant's financial management systems conform to the financial accountability standards that provide for and incorporate the following:
 - a. Accurate, current, and complete disclosure of the financial results of each federally-sponsored project;
 - b. Records which identify the source and application of funds for federally-sponsored activities. These records contain information pertaining to Federal awards, authorizations, obligations, un-obligated balances, assets, outlays, income, and interest;
 - c. Control over and accountability for all funds, property and other assets; adequate safeguards of all such assets shall be adopted to assure that all assets are used solely for authorized purposes;
 - d. Comparison of outlays with budget amounts for each award;
 - e. Written procedures to minimize the time elapsing between the receipt of funds and the issuance or redemption of checks for program purposes by the recipient;
 - f. Written procedures for determining the reasonableness, allocability, and allowability of costs in accordance with the provisions of Federal cost principles and the terms and conditions of the award;
 - g. Accounting record, including cost accounting records that are supported by source documentation.
 - h. Applicant's fiscal year period is 1-Jan to 31-Dec and its total operating budget is \$ 50,000 for FY 2017. Applicant will receive \$ - from other Participating Jurisdictions in CHDO Operating funds, and/or educational support funds, and \$ 50,000 in total CHDO Operating funds from the Department.

By: 
Signature of Authorized Representative
 Rick Sims
Printed Name
2/22/2017
Date

I, the undersigned, a Notary Public in and for said County and State, do hereby certify that Rick Sims who signed the foregoing statement, and who is known to be one in the same, has acknowledged before me on this date, that being informed of the contents of this statement, executed the same voluntarily on the date same foregoing statement bears.

GIVEN UNDER MY HAND AND SEAL OF OFFICE this 22 day of February 20 17

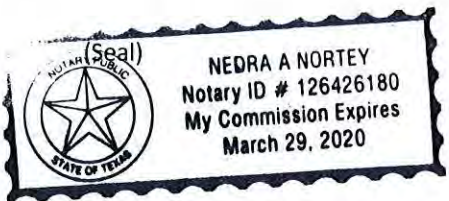

Notary Public Signature
Texas
Notary Public, State of
Dallas
County of
03.29.2020
My Commission Expires

2017 Affidavit of Low-Income Board Representation - Low Income Representative

Board members meeting Low Income Representation requirement must complete this affidavit

I represent the interests of low-income families in this organization's targeted service area. I have checked the below manner in which I meet the qualification as a low-income representative.

- I qualify as a low-income resident under the HOME Program definition. The gross annual income of my household of 2 people is at or below 80% of the Brazos county area median income in the amount of \$37,000.00 (80% AMI limit); OR
- I live in a low-income area (where 51% or more of the households in my US Census tract have incomes at or below 80% of the median household income, as defined by HUD), which is part of the CHDO's targeted service area. My census tract is _____ (census tract number). The Census tract data must accompany this certification. OR
- I am an elected representative of _____ (name of low-income neighborhood organization), located within _____ (name of neighborhood and city) which is part of the CHDO's targeted service area. A signed resolution or signed minutes and election roster from the neighborhood organization naming the individual as its representative on the CHDO's board of directors must be provided.

AND

- Further, I have completed an accompanying CHDO Board Member Certification as to my status as a Public Official/Governmental Employee and re-affirm here that I am not a public official, employee, or appointee of a governmental entity. (Note: Board members who are public officials/governmental employees may not be counted as a Low Income Representatives for purposes of CHDO qualification.)

I certify that the above statement is true and correct. I understand that any misstatement or falsification of information shall be grounds for denial or revocation of certification for CHDO status. If my status as a Low Income Representative changes at any time during my tenure on the board, I will immediately notify the board chair and executive director in writing and update my certification.

By: 

 Signature of Authorized Representative
 Alethea Smith

 Printed Name
 Board Member

 Title
02/26/2017

 Date

I, the undersigned, a Notary Public in and for said County and State, do hereby certify that is signed Alethea Smith who signed the foregoing statement, and who is known to be one in the same, has acknowledged before me on this date, that being informed of the contents of this statement, executed the same voluntarily on the date same foregoing statement bears.

GIVEN UNDER MY HAND AND SEAL OF OFFICE this 26th day of February 20 17

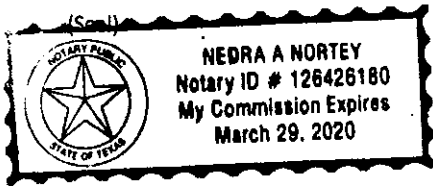

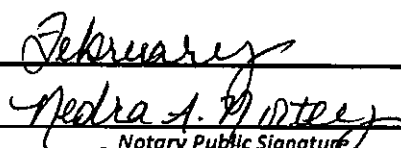

 Notary Public Signature
Texas

 Notary Public, State of
Dallas

 County of
03.29.2020

 My commission expires

2017 Affidavit of Low-Income Board Representation - Authorized Representative

I hereby certify that the individuals identified in the following affidavits are residents of a low income neighborhood, other low-income community resident, or elected representative of a low income neighborhood organization and is an active member of the Board of Directors of No Limit IEDC, a private nonprofit corporation.

"Low income" is defined as households whose annual incomes do not exceed 80% of the median income for the area, as determined by HUD with adjustments for smaller and larger families.

I certify that the above statement is true and correct. I understand that any misstatement or falsification of information shall be grounds for denial or revocation of certification for CHDO status.

By: [Signature]
Signature of Authorized Representative
Arlthea Smith
Printed Name
Director
Title
February 17 2017
Date

I, the undersigned, a Notary Public in and for said County and State, do hereby certify that Arlthea Smith who signed the foregoing statement, and who is known to be one in the same, has acknowledged before me on this date, that being informed of the contents of this statement, executed the same voluntarily on the date same foregoing statement bears.

GIVEN UNDER MY HAND AND SEAL OF OFFICE this 26th day of February 20 17

(Seal)

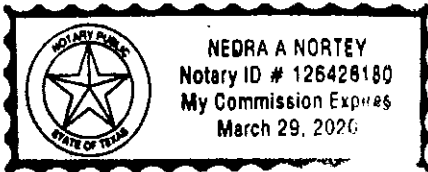

[Signature]
Notary Public Signature
Texas
Notary Public, State of
Dallas
County of
03.29.2020
My comission expires

2017 Affidavit of Low-Income Board Representation - Low Income Representative

Board members meeting Low Income Representation requirement must complete this affidavit

I represent the interests of low-income families in this organization's targeted service area. I have checked the below manner in which I meet the qualification as a low-income representative.

- I qualify as a low-income resident under the HOME Program definition. The gross annual income of my household of 3 people is at or below 80% of the Brazos county area median income in the amount of \$42,000.00 (80% AMI limit); OR
- I live in a low-income area (where 51% or more of the households in my US Census tract have incomes at or below 80% of the median household income, as defined by HUD), which is part of the CHDO's targeted service area. My census tract is _____ (census tract number). The Census tract data must accompany this certification. OR
- I am an elected representative of _____ (name of low-income neighborhood organization), located within _____ (name of neighborhood and city) which is part of the CHDO's targeted service area. A signed resolution or signed minutes and election roster from the neighborhood organization naming the individual as its representative on the CHDO's board of directors must be provided.

AND

Further, I have completed an accompanying CHDO Board Member Certification as to my status as a Public Official/Governmental Employee and re-affirm here that I am not a public official, employee, or appointee of a governmental entity. (Note: Board members who are public officials/governmental employees may not be counted as a Low Income Representatives for purposes of CHDO qualification.)

I certify that the above statement is true and correct. I understand that any misstatement or falsification of information shall be grounds for denial or revocation of certification for CHDO status. If my status as a Low Income Representative changes at any time during my tenure on the board, I will immediately notify the board chair and executive director in writing and update my certification.

By: Tareysha Cooper-Collins
 Signature of Authorized Representative
 Tareysha Cooper-Collins
 Printed Name
 Board Member
 Title
2-26-2017
 Date

I, the undersigned, a Notary Public in and for said County and State, do hereby certify that is signed Tareysha Cooper-Collins who signed the foregoing statement, and who is known to be one in the same, has acknowledged before me on this date, that being informed of the contents of this statement, executed the same voluntarily on the date same foregoing statement bears.

GIVEN UNDER MY HAND AND SEAL OF OFFICE this 26th day of February 2017

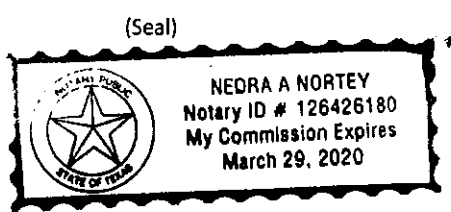

Nedra A. Northey
 Notary Public Signature
Texas
 Notary Public, State of
Dallas
 County of
03.29.2020
 My commission expires

2017 Affidavit of Low-Income Board Representation - Authorized Representative

I hereby certify that the individuals identified in the following affidavits are residents of a low income neighborhood, other low-income community resident, or elected representative of a low income neighborhood organization and is an active member of the Board of Directors of No Limit IEDC, a private nonprofit corporation.

"Low Income" is defined as households whose annual incomes do not exceed 80% of the median income for the area, as determined by HUD with adjustments for smaller and larger families.

I certify that the above statement is true and correct. I understand that any misstatement or falsification of information shall be grounds for denial or revocation of certification for CHDO status.

By: Tareysha Cooper-Collins
Signature of Authorized Representative
Tareysha Cooper-Collins
Printed Name
Director
Title
February 17 2017
Date

I, the undersigned, a Notary Public in and for said County and State, do hereby certify that Tareysha Cooper-Collins who signed the foregoing statement, and who is known to be one in the same, has acknowledged before me on this date, that being informed of the contents of this statement, executed the same voluntarily on the date same foregoing statement bears.

GIVEN UNDER MY HAND AND SEAL OF OFFICE this 26 day of February 20 17

(Seal)

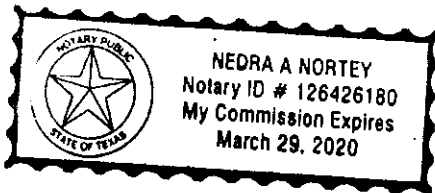

Nedra Northey
Notary Public Signature
Texas
Notary Public, State of
Dallas
County of
03.29.2020
My commission expires

Formal Process for State and Local Government Input

No Limit IEDC

RESOLUTION NO 201702261

The Chairman of the Board submits the following resolution for consideration by the Board of Directors:

FORMAL PROCESS FOR State or Local Government Input

NO LIMIT IEDC will provide a formal process for State and Local government to appoint collectively no greater than 1/3 membership of the organization governing body . The process will include beneficiary input in the design, siting, development, and management the affordable housing the organization participates in developing or owning.

NO LIMIT IEDC at a minimum will implement the formal process for public input by holding neighborhood advisory meetings at least bi-annually. Also, the organization will make the community aware of any housing developments it undertakes through broadcast media, flyers, contacts with a broad array of social service agencies, and newspaper articles. It will also accept public comment at all times via telephone, mail, e-mail, and other forms of communication. Comment may be directed to the organization's Executive Director, Rick Sims, via regular mail at 2002 Hwy 21 S. Bryan Texas 75667, or by telephone at(318)349-1588 or by e-mailatRrsim s90@aol.com .

Signed:

Tomi R. Johnson Tomi R. Johnson
(Name)
Secretary
(Title)

Approved by No Limit IEDC (Applicant's) Board meeting on
Feb. 26, 2017 as witnessed by: [Signature] (Name),
Rick Sims (Board Secretary). ED

Formal Process for Low-Income Input

No Limit IEDC

RESOLUTION NO 20170226Z

The Chairman of the Board submits the following resolution for consideration by the Board of Directors:

FORMAL PROCESS FOR PUBLIC INPUT

NO LIMIT IEDC will provide a formal process for low-income beneficiaries to advise the organization. The process will include beneficiary input in the design, siting, development, and management the affordable housing the organization participates in developing or owning.

NO LIMIT IEDC at a minimum will implement the formal process for public input by holding neighborhood advisory meetings at least bi-annually. Also, the organization will make the community aware of any housing developments it undertakes through broadcast media, flyers, contacts with a broad array of social service agencies, and newspaper articles. It will also accept public comment at all times via telephone, mail, e-mail, and other forms of communication. Comment may be directed to the organization's Executive Director, Rick Sims, via regular mail at 2002 Hwy 21 S. Bryan Texas 75667, or by telephone at (318) 349-1588 or by e-mail at Rrsim s90@aol.com.

Signed:

Tomi R. Johnson Dani R. Johnson
(Name)
Secretary
(Title)

Approved by No Limit IEDC (Applicant's) Board meeting on
Feb 26 2017 as witnessed by: [Signature] (Name),
Rick Sims (Board Secretary) E.D.

LIST OF THE NONPROFIT ORGANIZATION'S BOARD MEMBERS, DIRECTORS AND OFFICERS

Warren Roberts		President	
Name		Title	
2017 Old Hearne Rd		Bryan	TX 77803
Address		City	State Zip
		Pastor	
Phone		Ext.	Fax or Email
		Occupation	
Tomi Johnson		Vice President	
Name		Title	
2326 Yellowstone Dr		Bryan	TX 77803
Address		City	State Zip
		Administration	
Phone		Ext.	Fax or Email
		Occupation	
Lisa Mitchell		Director	
Name		Title	
1007 S FM 908		Rockdale	TX 76567
Address		City	State Zip
(512) 867-1323		Administration	
Phone		Ext.	Fax or Email
		Occupation	
Alethea Smith		Low Income Representative	
Name		Title	
5004 Stevenson St		Bryan	Tx 77807
Address		City	State Zip
		Clerical	
Phone		Ext.	Fax or Email
		Occupation	
Tareysha Cooper-Collins		Low Income Rep	
Name		Title	
6694 Allen Rd		Bryan	Tx 77807
Address		City	State Zip
		Clerical	
Phone		Ext.	Fax or Email
		Occupation	
Vacant		State Rep-	
Name		Title	
Address		City	State Zip
Phone		Ext.	Fax or Email
		Occupation	
Vacant		City Council	
Name		Title	
Address		City	State Zip
Phone		Ext.	Fax or Email
		Occupation	

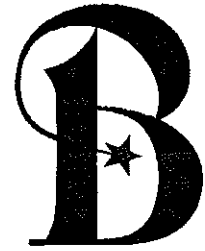

CITY OF BRYAN
The Good Life, Texas Style.

September 24, 2009

Mr. Terry Roberts, Executive Director
No Limits IEDC
2002 Hwy 21 East
Bryan, TX 77806

Re: Community Housing Development Organization Application

Dear Mr. Roberts:

The City of Bryan has evaluated and approved the No Limits International Economic Development Corporation (IEDC) Community Development Housing Organization (CHDO) application. This evaluation of No Limits IEDC finds that all Community Housing Development Organization (CHDO) requirements have been met, and that the agency is eligible for Home Investment Partnerships Program (HOME) CHDO allocations and funding.

The following criteria were evaluated in compliance with the Home Investment Partnerships Program Section 92.2 Subpart G:

I. Legal Status:

- A. Excluded Parties List System search for all board members, officers, and business names reveals no debarred parties.
- B. Articles of incorporation (A Texas, non-profit corporation) as evidenced by a certificate of formation filed with the Office of the Secretary of State of Texas.
- C. Statement of non-injuring benefits to members, founders, contributors or individuals is contained in the articles of the Certificate of Formation, Article 5, Section 3, page 3.
- D. Tax exempt status as evidenced by 501(c)(3) certificate #31125 issued October 16, 2008 by the Internal Revenue Service.

II. Capacity:

- A. Conforms to the financial accountability standards of 24 CFR 84.21, as evidenced by a Notarized Statement from the Chief Financial Officer.
- B. Has demonstrated capacity for carrying out activities similar to projects to be assisted with HOME funds by providing resume's and statements of key staff members, and by successful construction and sale of two prior low-moderate income single-family housing projects: 708 W MLK, and 805 N Congress, both completed February 26, 2008.
- C. Has a history of serving the community where housing to be assisted by HOME funds will be used, as evidenced by documents and statements reflecting at least one year of experience in serving the community.

III. Organizational Structure:

- A. Maintains at least one-third of its governing board's membership for residents of low income neighborhoods, other low income community residents, or representatives of low income neighborhood organizations, as evidenced by the organizations bylaws, a current roster of board representation, an affidavit of board representation, individual affidavits of low-mod income status, and census-tract verification of low-moderate income neighborhood residency.
- B. Provides a formal process for low-income, program beneficiaries to advise the organization in its decisions regarding the design, siting, development, and management of all affordable housing projects, as evidenced by a corporate resolution.
- C. The State or local government may not appoint more than one-third of the membership of the organization's governing body and no more than one-third of the organization's governing board membership are public officials, as evidenced by the organization's bylaws, the roster of board representation, the affidavit of board representation, and individual affidavits.

IV. Relationship with For-Profit Entities:

The organization is not controlled, nor receives directions from individuals, or entities seeking profit from the organization, as evidenced by the organization's by-laws.

No Limits will be informed of CHDO training opportunities as they become available. Key staff will be strongly encouraged to attend. In the meantime, please refer to the resources enclosed for information regarding regulatory compliance for CHDO's. Community Development Services staff are available to assist with all aspects of project planning and implementation, including acquisition procedures, required federal notices, environmental review, income verification, and all other project regulatory and technical requirements.

CHDO funding availability will be announced in October through a competitive Request for Proposals process for certified CHDO's in the City of Bryan. We are available to answer any questions you may have, and look forward to your organization's participation in the development of affordable housing in the City of Bryan.

Sincerely, -

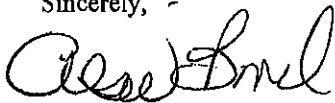

Alsie Bond, Manager
Community Development Services Department

cc: Art Roach, Assistant Manager, Community Development Services
Eric Barton, Construction Project Specialist
File

Enc/1 CHDO/Nonprofit Development Resources

CHDO/Nonprofit Development Resources

CHDO Toolbox for HOME PJs:

<http://www.hud.gov/offices/cpd/affordablehousing/library/modelguides/2004/200408.pdf>

DEVELOPING PROJECTS WITH HOME FUNDS

<http://www.hud.gov/offices/cpd/library/relocation/publications/nonprofitrelocation.pdf>

Real Estate Acquisition and Relocation Policy and Guidance HUD Handbook 1378

<http://www.hud.gov/offices/cpd/library/relocation/policyandguidance/handbook1378.cfm>

49 CFR Part 24 Code of Federal Regulations – Uniform Relocation Assistance and Real Property Acquisition

<http://ecfr.gpoaccess.gov/cgi/t/text/text-idx?c=ecfr&sid=4b130c71709cf33dd27a942ac4e391be&rgn=div5&view=text&node=49:1.0.1.1.17&idno=49>

Income Limits (60% for initial occupancy, Low Income (80%) for subsequent occupants)

<http://www.hud.gov/offices/cpd/affordablehousing/programs/home/limits/income/2009/tx.pdf>

Technical Guide For Determining Income – HUD Calculator

<https://webapps1.hud.gov/hfc/calculator/>

RESOLUTION NO. 3445

A RESOLUTION OF THE CITY OF BRYAN, TEXAS: APPROVING CONTRACTS FOR THE ALLOCATION OF HOME INVESTMENT PARTNERSHIPS PROGRAM FUNDS TO QUALIFIED COMMUNITY HOUSING DEVELOPMENT ORGANIZATIONS; AUTHORIZING THE MAYOR TO EXECUTE THE CONTRACTS; AND PROVIDING AN EFFECTIVE DATE.

WHEREAS, the City of Bryan, Texas ("City") is a home rule municipality duly incorporated and chartered under the Constitution and laws of Texas; and

WHEREAS, the City has the objective of providing for the development of low-to-moderate-income housing for citizens of the City; and

WHEREAS, the City is required by federal Department of Housing and Urban Development (HUD) regulations to reserve no less than fifteen percent (15%) of its annual HOME Investment Partnerships Program (HOME) Grant for use by Community Housing Development Organizations (CHDO's) for the development of affordable housing; and

WHEREAS, the non-profit recipients, Elder Aid, Inc. and No Limits International Economic Development, Inc., have been determined to meet the requirements of a Community Housing Development Organization; and

WHEREAS, these CHDO's have submitted proposals for the development of affordable housing in response to RFP #12-032; and

WHEREAS, the construction of affordable housing through the CHDO is in accordance with the City's current 5-Year Consolidated Plan and current Annual Action Plan;

NOW, THEREFORE, BE IT RESOLVED BY THE CITY COUNCIL OF THE CITY OF BRYAN, TEXAS:

SECTION 1

That the City Council of the City of Bryan, Texas, hereby officially determines that the City is authorized to contract for the allocation of HOME funds for the development of low to moderate income housing with the following Non-Profit CHDO recipients:

Elder Aid, Inc.:\$70,782 from 2010 HOME CHDO Set-Aside Funds

No Limits International Economic Development, Inc.: \$62,662 from 2011 HOME CHDO Set-Aside Funds and \$8,120 from 2010 HOME funds.

SECTION 2

That the attached contracts for HOME Programs with Community Housing Development Organizations are hereby approved.

SECTION 3

That the Mayor is hereby authorized to execute the contracts for HOME Programs.

SECTION 4

That this Resolution shall become effective immediately upon adoption.

APPROVED AND ADOPTED at a Regular City Council Meeting, this 28th day of August, 2012.

ATTEST:

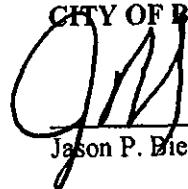

Mary Lynne Stratta, City Secretary

CITY OF BRYAN

Jason P. Dzienski, Mayor

APPROVED AS TO FORM:

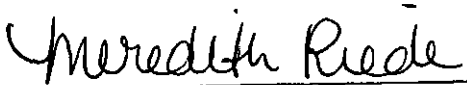
for 

Janis K. Hampton, City Attorney

VENDOR NAME	CHECK NO.	DATE	TOTAL
NO LIMITS INTERNATIONAL	432007	Jan-08-2013	\$65,123.44

VOUCHER NO.	AMOUNT	VENDOR INV	DESCRIPTION	DATE
PI5430	30,844.65	705 E. PRUITT #1	BUILDING MAINTENANCE/REP	01/02/13
PI5431	34,278.79	606 W. 21 #1	BUILDING MAINTENANCE/REP	01/02/13

FOR INQUIRIES CALL (979) 209-5080

CHECK IS VOID IF ANY OF THE FOLLOWING SECURITY FEATURES ARE ABSENT: ORIGINAL DOCUMENT PRINTED ON CHEMICAL REACTIVE PAPER



City of Bryan
 CENTRAL DISBURSEMENT
 P.O. Box 1000
 Bryan, Texas 77805

Citibank, N.A.
 1111 Briarcrest Dr.
 Bryan, TX 77802

88-9353 Check No. **432007**
 1131

DATE	AMOUNT
Jan-08-2013	\$65,123.44

VOID AFTER 120 DAYS

PAY EXACTLY *** **65,123dols44cts** ***
 SIXTY FIVE THOUSAND ONE HUNDRED TWENTY THREE AND 44/100 DOLLARS

TO THE ORDER OF

NO LIMITS INTERNATIONAL
 ECONOMIC DEVELOPMENT, INC.
 2002 HWY 21 EAST
 BRYAN TX 77806

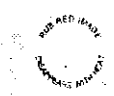

By *Jason Brenshi*
 By *[Signature]*
 AUTHORIZED SIGNATURES

RUB RED IMAGE. - DISAPPEARS WITH HEAT.

SECURITY FEATURES INCLUDED, DETAILS ON BACK.

SEE BACK FOR ARTIFICIAL WATERMARK

⑈432007⑈ ⑆113193532⑆ 9773995977⑈

**CONTRACT FOR
HOME PROGRAMS
Community Housing Development Organization**

Article I. PARTIES

Section 1.01 This HOME Investment Partnerships Program (HOME) Community Housing Development Organization (CHDO) Contract for HOME Programs (the "Contract") is between the City of Bryan ("City"), a political subdivision of the State of Texas, and, **No Limits International Economic Development, Inc.**, ("Recipient"), a Texas Non-Profit Corporation (collectively referred to herein as the "Parties").

Article II. CONTRACT PERIOD

Section 2.01 This Agreement shall commence when executed by all parties and terminate on August 27, 2014, unless extended by agreement of the Parties in writing.

Article III. RECIPIENT PERFORMANCE

Section 3.01 Recipient shall act in the role of Non-Profit Owner and Developer of affordable single-family homebuyer or rental housing in accordance with the HOME INVESTMENT PARTNERSHIPS ACT OF 1990, 42 U.S.C. 12701 ET SEQ. (THE ACT) and the implementing regulations, 24 CFR PART 92, TEXAS LOCAL GOVERNMENT CODE SECTION 373.001 ET SEQ., and the HOME INVESTMENT PARTNERSHIPS PROGRAM RULES. Recipient shall perform all activities in accordance with the terms of the Performance Statement, ("Exhibit A" attached hereto); the Budget, ("Exhibit B" attached hereto); the Project Implementation Schedule, ("Exhibit C" attached hereto); the Applicable Laws and Regulations, ("Exhibit D" attached hereto); the Certifications, ("Exhibit E" attached hereto); the Community Development Services Residential Construction Standards ("Exhibit F" attached hereto), Volunteer Release and Indemnification Agreement ("Exhibit G" attached hereto), the Land Use Restriction Agreement for rental developments ("Exhibit H" attached hereto) the assurances, covenants, warranties, certifications, and all other statements made by Recipient in its application for the project funded under this Agreement; and with all other terms, provisions, and requirements set forth in this Agreement.

Section 3.02 Recipient shall perform all activities in the Performance Statement within two (2) years of date of execution of this Agreement.

Section 3.03 In the event the affordability requirements of 24 CFR Part 92 are not satisfied by Recipient hereunder, Recipient shall bear ultimate responsibility for repayment of HOME funds.

Section 3.04 In the event that there is program income, repayments, and/or recaptured funds, the funds must be used in accordance with the requirements of 24 CFR 92.503, as outlined in the Performance Statement, "Exhibit A".

Section 3.05 Recipient agrees to maintain itself as a CHDO in accordance with Title II of the National Affordable Housing Act (1990), as it may be amended, concerning the HOME Investment Partnership program (HOME) and 24 CFR 92.300.

Section 3.06 Recipient agrees that all applicants for housing funded under this agreement will be initially qualified and approved by the City of Bryan Community Development Services Department.

**CONTRACT FOR
HOME PROGRAMS
Community Housing Development Organization**

Article I. PARTIES

Section 1.01 This HOME Investment Partnerships Program (HOME) Community Housing Development Organization (CHDO) Contract for HOME Programs (the "Contract") is between the City of Bryan ("City"), a political subdivision of the State of Texas, and, **No Limits International Economic Development, Inc.**, ("Recipient"), a Texas Non-Profit Corporation (collectively referred to herein as the "Parties").

Article II. CONTRACT PERIOD

Section 2.01 This Agreement shall commence when executed by all parties and terminate on August 27, 2014, unless extended by agreement of the Parties in writing.

Article III. RECIPIENT PERFORMANCE

Section 3.01 Recipient shall act in the role of Non-Profit Owner and Developer of affordable single-family homebuyer or rental housing in accordance with the HOME INVESTMENT PARTNERSHIPS ACT OF 1990, 42 U.S.C. 12701 ET SEQ. (THE ACT) and the implementing regulations, 24 CFR PART 92, TEXAS LOCAL GOVERNMENT CODE SECTION 373.001 ET SEQ., and the HOME INVESTMENT PARTNERSHIPS PROGRAM RULES. Recipient shall perform all activities in accordance with the terms of the Performance Statement, ("Exhibit A" attached hereto); the Budget, ("Exhibit B" attached hereto); the Project Implementation Schedule, ("Exhibit C" attached hereto); the Applicable Laws and Regulations, ("Exhibit D" attached hereto); the Certifications, ("Exhibit E" attached hereto); the Community Development Services Residential Construction Standards ("Exhibit F" attached hereto), Volunteer Release and Indemnification Agreement ("Exhibit G" attached hereto), the Land Use Restriction Agreement for rental developments ("Exhibit H" attached hereto) the assurances, covenants, warranties, certifications, and all other statements made by Recipient in its application for the project funded under this Agreement; and with all other terms, provisions, and requirements set forth in this Agreement.

Section 3.02 Recipient shall perform all activities in the Performance Statement within two (2) years of date of execution of this Agreement.

Section 3.03 In the event the affordability requirements of 24 CFR Part 92 are not satisfied by Recipient hereunder, Recipient shall bear ultimate responsibility for repayment of HOME funds.

Section 3.04 In the event that there is program income, repayments, and/or recaptured funds, the funds must be used in accordance with the requirements of 24 CFR 92.503, as outlined in the Performance Statement, "Exhibit A".

Section 3.05 Recipient agrees to maintain itself as a CHDO in accordance with Title 11 of the National Affordable Housing Act (1990), as it may be amended, concerning the HOME Investment Partnership program (HOME) and 24 CFR 92.300.

Section 3.06 Recipient agrees that all applicants for housing funded under this agreement will be initially qualified and approved by the City of Bryan Community Development Services Department.

Section 3.07 Recipient Insurance Recipient agrees to obtain and maintain, at a minimum, the insurance coverage, endorsements, and limits as set forth below for the duration of the contract:

- (a) **Workers' Compensation Insurance & Employers' Liability Insurance** – Statutory & \$500,000/\$500,000/\$500,000. Recipient agrees to maintain Worker's Compensation Insurance & Employers Liability. Waiver of subrogation in favor of the City required. This requirement may be waived with satisfactory evidence that the Recipient is a sole proprietor(s) having no employees and/or has no employees working on this construction project. This requirement may also be waived for volunteers with a signed Volunteer Release and Indemnification Agreement.
- (b) **Commercial General Liability Insurance** – Limit of liability not less than \$500,000 per occurrence. Recipient agrees to maintain a standard ISO version Commercial General Liability occurrence form, or its equivalent providing coverage for, but not limited to, Bodily Injury and Property Damage, Premises/Operations, Products/Completed Operations, Independent Contractors. Additional insured endorsement required.
- (c) **BUILDER'S RISK** – Limit not less than 100% of the total projected construction value at completion of the project. Recipient agrees to maintain Builder's Risk insurance providing coverage to protect the interests of the City, Recipient, sub-contractors, including property in transit and property on or off-premises, which shall become a part of the building or project. Coverage shall be written on an All-Risk, Replacement Cost, and Completed Value Form basis. Loss Payee endorsement required. This requirement may be waived with satisfactory evidence that the Recipient has contracted for all construction activities, and the contractor and subcontractors have obtained the required insurance policies and coverage.

Section 3.08 The Recipient shall include, in addition to provisions to define a sound and complete agreement, the following provisions in all contracts as specified:

- (a) For those contracts or subcontracts which exceed \$25,000, a payment bond on the part of the contractor or subcontractor shall be issued for the protection of the CHDO for 100 percent of the contract or subcontract price.
- (b) For those contracts or subcontracts which exceed \$100,000, a performance bond on the part of the contractor or subcontractor shall be issued for the protection of the City of Bryan in the amount of the contract or subcontract, conditioned on the faithful performance of the work in accordance with the plans, specifications, and contract documents.
- (c) Contractor agrees to obtain and maintain the insurance coverage, endorsements, and limit as set forth below for the duration of the contract:
 - (a) **Workers' Compensation Insurance & Employers' Liability Insurance** – Statutory & \$500,000/\$500,000/\$500,000. Contractor agrees to maintain Worker's Compensation Insurance & Employers Liability. In the event any work is sublet, the Contractor shall require the subcontractor similarly to provide the same coverage and shall himself acquire evidence of such coverage on behalf of the subcontractor. Waiver of subrogation in favor of the CHDO required. This requirement may be waived with satisfactory evidence that the contractor is a sole proprietor(s) having no employees.
 - (b) **Commercial General Liability Insurance** – Limit of liability not less than \$500,000 per occurrence. Contractor agrees to maintain a standard ISO version Commercial General Liability occurrence form, or its equivalent providing coverage for, but not limited to, Bodily Injury and Property Damage, Premises/Operations, Products/Completed

Operations, Independent Contractors. Additional insured endorsement naming the Recipient is required.

Article IV. CITY OBLIGATIONS

Section 4.01 Measure of Liability. In consideration of full and satisfactory performance of the activities referred to in Article V of this Agreement, City shall be liable for actual and reasonable costs incurred by Recipient during the Agreement period for performances rendered under this Agreement by Recipient, subject to the limitations set forth in this Article IV.

- (a) The Parties agree that City's obligations to meet City's liabilities under Article IV of this Agreement are contingent upon the actual receipt of adequate local and/or federal funds. If adequate funds are not available to make payments under this Agreement, City shall notify Recipient in writing within a reasonable time after such fact is determined. City shall then terminate this Agreement and shall not be liable for failure to make payments to Recipient under this Agreement.
- (b) City shall not be liable to Recipient for any costs incurred by Recipient, or any portion thereof, which have been paid to Recipient or which are subject to payment to Recipient, or which have been reimbursed to Recipient, or are subject to reimbursement to Recipient, by any source other than City or Recipient.
- (c) City shall not be liable to Recipient for any costs incurred by Recipient which are not eligible project costs, as set forth in 24 CFR 92.206(A) and Article VI of this Agreement. Funds provided under this Agreement shall not be used nor shall City be liable for payment of costs associated directly or indirectly incurred because of prohibited activities as defined in 24 CFR 92.214.
- (d) City shall not be liable to Recipient for any costs incurred by Recipient or for any performances rendered by Recipient which are not strictly in accordance with the terms of this Agreement, including the terms of Exhibits A, B, C, D, E F and G of this Agreement.
- (e) City shall not be liable for costs incurred or performance rendered by Recipient before commencement or after termination of this Agreement.

Section 4.02 LIMIT OF LIABILITY. NOTWITHSTANDING ANY OTHER PROVISION OF THIS AGREEMENT, THE TOTAL OF ALL PAYMENTS AND OTHER OBLIGATIONS INCURRED BY CITY UNDER THIS AGREEMENT SHALL UNDER NO CIRCUMSTANCES EXCEED SEVENTY THOUSAND, SEVEN HUNDRED EIGHTY-TWO AND NO/100, (\$70,782.00), FROM THE FY 2012 BUDGET (\$62,662 FROM HUD GRANT YEAR 2011 AND \$8,120 FROM HUD GRANT YEAR 2010).

Article V. DISBURSEMENT OF FUNDS

Section 5.01 City shall pay costs incurred which it determines are eligible and which are properly submitted under this Agreement in accordance with the requirements of 24 CFR 92.502. Recipient may not request disbursement of funds under this Agreement until the funds are needed for payment of eligible costs. The amount of each request must be limited to the amount of money needed to pay eligible costs actually incurred, and may not include amounts for prospective or future needs. Reimbursement requests shall contain an itemization of each expense item, and documentation, including paid receipts, invoices, signed draw requests, signed change orders, and canceled checks. Recipient may use up to ten percent (10%) of the grant amount for eligible program delivery expenses but in no case shall program delivery

expenses exceed 10% of the project cost or funded amount, whichever is less, as determined by the City. These costs may include but are not limited to: Architectural, engineering or related professional services required to prepare plans, drawings, specifications, or work write-ups, costs to process and settle financing, such as private lender origination fees, credit reports, fees for title evidence, fees for recordation and filing of legal documents, building permits, impact fees, attorney's fees, private appraisal fees and fees for an independent cost estimate, builders or developers fees, staff and overhead costs directly related to carrying out the project, such as work specifications preparation, loan processing inspections, and other services related to assisting potential owners, tenants, and homebuyers. General administrative expenses of the CHDO are not eligible program delivery expenses.

Section 5.02 Any and all Program Income as defined by 24 CFR 84.2 must be disbursed by Recipient prior to requesting a disbursement of funds from the City. CHDO proceeds from the sale of properties developed under this agreement are not to be considered program income but may be retained by the CHDO as allowed under 24 CFR 92.300(a)(2), however, all such proceeds must be used for future HOME-eligible projects within the jurisdictional boundaries of the City of Bryan.

Section 5.03 The Parties agree that City's obligations to make payments under this Agreement are contingent upon Recipient's full and satisfactory performance of its obligations under this Agreement. City reserves the right to recover, recapture or offset funds paid under this Agreement in the event City determines that Recipient will be unable to commit or expend funds within the prescribed time, as determined by City. Recipient agrees to refund to the City all funds that the City in its sole discretion determines to have been used for ineligible and/or unapproved purposes. Such refunds will be made within thirty (30) days of notification by the City of the ineligible expenditure.

Section 5.04 The Parties agree that any right or remedy provided for in this Article V or in any other provision of this Agreement is cumulative, and shall not preclude the exercise of any other right or remedy under this Agreement or under any provision of law, nor shall any action taken in the exercise of any right or remedy be deemed a waiver of any other rights or remedies. Failure to exercise any right or remedy hereunder shall not constitute a waiver of the right to exercise that or any other right or remedy at any time.

Article VI. UNIFORM ADMINISTRATIVE REQUIREMENTS, COSTS PRINCIPLES AND PROGRAM INCOME FOR GOVERNMENT ENTITIES AND NON-PROFITS

Section 6.01 Recipient shall comply with the requirements of OMB Circulars Number. A-122 "COST PRINCIPALS FOR NON PROFIT ORGANIZATIONS", OMB Circular Number A-110 "UNIFORM ADMINISTRATIVE REQUIREMENTS FOR GRANTS AND OTHER AGREEMENTS WITH INSTITUTIONS OF HIGHER EDUCATION, HOSPITALS, AND OTHER NON PROFIT ORGANIZATIONS, and 24 CFR Part 84 "UNIFORM ADMINISTRATIVE REQUIREMENTS FOR GRANTS AND AGREEMENTS WITH INSTITUTIONS OF HIGHER EDUCATION, HOSPITALS, AND OTHER NON PROFIT ORGANIZATIONS", and any other OMB Circulars which may apply either prospectively or retroactively. Recipient nonprofit organization must comply with applicable OMB Circulars pursuant to 24 CFR 92.505 and any other applicable regulations.

Article VII. RETENTION AND ACCESSIBILITY OF RECORDS

Section 7.01 Recipient must establish and maintain sufficient records, including those listed under 24 CFR 92.508. The sufficiency of the records will be determined by City.

Section 7.02 Recipient shall give HUD, the Comptroller General of the United States, the City of
Contract for Home Programs: No Limits IEDC

Bryan Auditor, or any of their duly authorized representatives, access to and the right to examine all books, accounts, records, reports, files, and other papers, things, or property belonging to or in use by Recipient pertaining to this Agreement. Such rights to access shall continue as long as the records are retained by Recipient. Recipient agrees to maintain such records in a location accessible to the above-named persons and entities.

Section 7.03 All records pertinent to this Agreement shall be retained by Recipient for five calendar years after the date of termination of this Agreement or of submission of the final close-out report, whichever is later, with the following exceptions:

- (a) If any litigation, claim or audit is started before the expiration of the five-year period and extends beyond the five-year period, the records will be maintained until all litigation, claims or audit findings involving the records have been finally resolved, including all legal and administrative appeals.
- (b) Records relating to real property acquisition shall be retained for the period of affordability required under 24 CFR Part 92.
- (c) Records covering displacement and acquisitions must be retained for at least five years after the date by which all persons displaced from the property and all persons whose property is acquired for the project have received the final payment to which they are entitled in accordance with 24 CFR 92.353.

Section 7.04 Recipient shall require the substance of this Article VII to be included in all subcontracts.

Section 7.05 Recipient must provide citizens, public agencies, and other interested parties with reasonable access to records consistent with the TEXAS PUBLIC INFORMATION ACT.

Article VIII. REPORTING REQUIREMENTS

Section 8.01 Recipient shall submit to City such reports on the operation and performance of this Agreement as may be required by City including but not limited to the reports specified in this Article VIII. Recipient shall provide City with all reports necessary for City's compliance with 24 CFR Sections 92.508, 92.509 and 24 CFR SUBPART J or any other applicable statute, law or regulation. Recipient agrees to furnish the City with information on program participants, including: income verifications, race, ethnicity, age, sex, family status, disability status and head-of-household status. Recipient will report any project and/or program delays or modifications and await City approval before proceeding. Recipient will also report any instances of client fraud or program abuse to the City. Recipient agrees to meet with the City to discuss progress or concerns as the need arises and at the City's request. Recipient also agrees to report on a bi-annual basis to the City on program/project status. This must be a written report of the status on recently completed, ongoing, and pre-approved programs and/or projects and must include information for the reporting period to include the status on: applicant approvals/denials; projects/programs approved; fund disbursements; project bidding information; property sales; contractor/subcontractor utilization to include: race, sex, ethnicity, addresses, social security numbers and amounts billed and paid; use of program income, repayments, and recaptured funds; and other information as specified by the City.

Section 8.02 In addition to the limitations on liability otherwise specified in this Agreement, it is expressly understood and agreed by the Parties hereto that if Recipient fails to submit to City in a timely and satisfactory manner any report required by this Agreement, City may, at its sole option and in its sole

discretion, withhold any or all payments otherwise due or requested by Recipient hereunder. If City withholds such payments, it shall notify Recipient in writing of its decision and the reasons therefore. Payments withheld pursuant to this paragraph may be held by City until such time as Recipient fully cures or performs any and all delinquent obligations which are identified as the reason funds are withheld.

Article IX. MONITORING

Section 9.01 The City reserves the right to carry out regular and periodic field inspections to ensure compliance with the requirements of this Agreement. Monitoring inspections may examine site work, project files, financial records, client files, intake records, or any other information as deemed applicable by the City. After each monitoring visit, City shall provide Recipient with a written report of the monitor's findings. If the monitoring reports note deficiencies in Recipient's performances under the terms of this Agreement, the monitoring report shall include requirements for the timely correction of such deficiencies by Recipient. Failure by Recipient to take action specified in the monitoring report may be cause for suspension or termination of this Agreement, as provided in Article XVIII and XIX of this Agreement.

Article X. INDEPENDENT CONTRACTOR

Section 10.01 It is expressly understood and agreed by the Parties hereto that City is contracting with Recipient as an Independent Contractor and not any employee, or agent of City. This Agreement does not establish or constitute a joint venture or enterprise between City and Recipient.

Section 10.02 By entering into this Agreement, City and Recipient do not intend to create a joint enterprise.

Article XI. INDEMNIFICATION

Section 11.01. RECIPIENT AGREES TO AND SHALL INDEMNIFY AND HOLD HARMLESS CITY, ITS PUBLIC OFFICIALS, OFFICERS, AGENTS AND EMPLOYEES FROM AND AGAINST ANY AND ALL CLAIMS, LOSSES, DEMANDS, JUDGMENTS AND CAUSES OF ACTION OF EVERY KIND AND CHARACTER INCLUDING REASONABLE ATTORNEY FEES, COSTS AND EXPERT FEES, WHICH MAY BE ASSERTED BY ANY THIRD PARTY OCCURRING OR IN ANY WAY INCIDENT TO, ARISING OUT OF, OR IN CONNECTION WITH THE SERVICES AND WORK TO BE PERFORMED BY RECIPIENT UNDER THIS AGREEMENT.

SECTION 11.02. BY ENTERING INTO THIS AGREEMENT THE CITY DOES NOT WAIVE ITS GOVERNMENTAL IMMUNITY, THE LIMITATIONS AS TO DAMAGES CONTAINED IN THE TEXAS TORT CLAIMS ACT OR CONSENT TO SUIT.

Article XII. SUBCONTRACTS

Section 12.01 Except for subcontracts to which the federal labor standards requirements apply (12 or more units), Recipient may not subcontract for performances of any obligation required or described in this Agreement without obtaining City's prior written approval. Recipient shall only subcontract for performance obligations required or described in this Agreement to which the federal labor standards requirements apply after Recipient has submitted a Subcontractor Eligibility form, as specified by City, for each such proposed subcontract and Recipient has obtained City's prior written approval, based on the information submitted, of Recipient's intent to enter into such proposed subcontract. Recipient, in

subcontracting for the performance of any obligation required as described in this Agreement, expressly understands that in entering into such subcontracts, City is in no way liable to Recipient's subcontractor(s).

Section 12.02 In no event shall any provision of this Article XII, specifically the requirement that Recipient obtain City's prior written approval of a subcontractor's eligibility, be construed as relieving Recipient of the responsibility for ensuring that the performances rendered under all subcontracts are rendered so as to comply with all of the terms of this Agreement, as if such performances rendered were rendered by Recipient. City's approval under Article XII does not constitute adoption, ratification, or acceptance of Recipient's or subcontractor's performance hereunder. City maintains the right to insist upon Recipient's full compliance with the terms of this Agreement, and by the act of approval under Article XII, City does not waive any rights or remedies which, may exist or which may subsequently accrue to City under this Agreement.

Section 12.03 Recipient shall comply with all applicable federal, state, and local laws, regulations, and ordinances for making procurement under this Agreement.

Section 12.04 Recipient shall submit a subcontractor utilization report prior to beginning work and prior to hiring any additional subcontractors.

Section 12.05 Recipient may utilize volunteer labor to accomplish the project, in which case the Recipient is responsible to ensure that the Volunteer Release and Indemnification Agreement (Exhibit G) shall be completed by each volunteer, and the original submitted to the City.

Article XIII. CONFLICT OF INTEREST

Section 13.01 No person who (a) is an employee, agent, consultant, officer or elected or appointed official of City or of any applicant that receives funds and who exercises or has exercised any functions or responsibilities with respect to activities assisted with funds provided under this Agreement or (b) who is in a position to participate in a decision-making process or gain inside information with regard to such activities may obtain a personal or financial interest or benefit from a HOME assisted activity, or have an interest in any contract, subcontract or agreement (or the proceeds thereof) with respect to a HOME assisted activity either for themselves or those with whom they have family or business ties, during their tenure or for one year thereafter. Recipient shall ensure compliance with applicable provisions under 24 CFR Sections 84.40 - 84.48 and OMB Circular A-110 in the procurement of property and services.

Article XIV. NONDISCRIMINATION AND SECTARIAN ACTIVITY

Section 14.01 Equal Opportunity. Recipient shall ensure that no person shall on the grounds of race, color, religion, sex, handicap, family status, or national origin be excluded from participation in, be denied the benefits of, or be subjected to discrimination under any program or activity funded in whole or in part with funds provided under this Agreement. In addition, funds provided under this Agreement must be made available in accordance with the requirements of Section 3 of the HOUSING AND URBAN DEVELOPMENT ACT OF 1968 (12USC1701u) that:

- (a) To the greatest extent feasible, opportunities for training and employment arising in connection with the planning and carrying out of any project assisted with HOME funds provided under this Agreement be given to low-income persons residing within the general local government area in which the project is located; and

- (b) To the greatest extent feasible, contracts for work to be performed in connection with any such project be awarded to business concerns, including, but not limited to, individuals or firms doing business in the field of planning, consulting, design, architecture, building construction, rehabilitation, maintenance, or repair, which are located in or owned in substantial part by persons residing in the same metropolitan area or non-metropolitan City as the project.

Section 14.02 Religious Organizations. Funds provided under this Agreement may not be provided to primarily religious organizations, such as churches, for any activity, including secular activities. In addition, funds provided under this Agreement may not be used to rehabilitate or construct housing owned by primarily religious organizations, such as churches, for any activity, including secular activities. In addition, funds provided under this Agreement may not be used to rehabilitate or construct housing owned by primarily religious organizations or to assist primarily religious organizations in acquiring housing. The completed housing project must be used exclusively by the owner entity for secular purposes and must be available to all persons regardless of religion. There must be no religious or membership criteria for tenants of the property as specified under 24 CFR 92.257.

Article XV. LEGAL AUTHORITY

Section 15.01 Recipient assures and guarantees that Recipient possesses the legal authority to enter into this Agreement, to receive funds authorized by this Agreement, and to perform the services Recipient has obligated itself to perform hereunder.

Section 15.02 The person or persons signing and executing this Agreement on behalf of Recipient, or representing themselves as signing and executing this Agreement on behalf of Recipient, do hereby warrant and guarantee that he, she or they have been duly authorized by Recipient to execute this Agreement on behalf of Recipient and to validly and legally bind Recipient to all terms, performances, and provisions herein set forth.

Section 15.03 Recipient shall not employ, award contract to, or fund any person that has been debarred, suspended, proposed for debarment, or placed on ineligibility status by U.S. Department of Housing and Urban Development. In addition, City shall have the right to suspend or terminate this Agreement if Recipient is debarred, suspended, proposed for debarment, or ineligible to participate in the HOME Program.

Article XVI. LITIGATION AND CLAIMS

Section 16.01 Recipient shall give City immediate notice in writing of a) any action, including any proceeding before an administrative agency, brought or filed against Recipient in connection with this Agreement; and b) any claim against Recipient, the cost and expense of which Recipient may be entitled to be reimbursed by City.

Except as otherwise directed by City, Recipient shall furnish immediately to City copies of all documents received by Recipient with respect to such action, proceeding, or claim.

Article XVII. CHANGES AND AMENDMENTS

Section 17.01 Except as specifically provided otherwise in this Agreement, any alterations, additions, or deletions to the terms of this Agreement shall be by amendment hereto in writing and executed by both the Parties to this Agreement.

Section 17.02 It is understood and agreed by the Parties hereto that any performance under this Agreement must be rendered in accordance with the Act, the regulations promulgated under the Act, the assurances and certifications made to City by Recipient, and the assurances and certifications made to the United States Department of Housing and Urban Development by the City with regard to the operation of the HOME Program.

Section 17.03 Any alterations, additions, or deletions to the terms of this Agreement which are required by changes in Federal or state law or regulations are automatically incorporated into this Agreement without written amendment hereto, and shall become effective on the date designated by such law or regulations. All other amendments to the Agreement must be in writing and signed by both Parties, except as provided in paragraphs 17.02 and 17.03.

Article XVIII. SUSPENSION

Section 18.01 In the event Recipient fails to comply with any term of this Agreement, City may, upon written notification to Recipient, suspend this Agreement in whole or in part and withhold further payments to Recipient, and prohibit Recipient from incurring additional obligations of funds under this Agreement.

Article XIX. TERMINATION

Section 19.01 The City may terminate this Agreement in whole or in part, in accordance with 24 CFR 85.43 and this Article or as provided in this Agreement. In the event Recipient materially fails as determined by City, to comply with any term of this Agreement, whether stated in a Federal statute or regulation, an assurance, in a City plan or application, a notice of award, or elsewhere, City may take one or more of the following actions:

- (a) Temporarily withhold cash payments pending correction of the deficiency or default by the Recipient.
- (b) Disallow all or part of the cost of the activity or action not in compliance; and require immediate repayment of such disallowed costs.
- (c) Withhold further HOME awards from Recipient.
- (d) Exercise other rights and remedies that may be legally available as determined by the City to comply with the terms of this Agreement.
- (e) City may terminate this Agreement for convenience in accordance with 24 CFR 85.44.

Article XX. AUDIT

Section 20.01 Unless otherwise directed by City, Recipient shall arrange for the performance of an annual financial and compliance audit of funds received and performances rendered under this Agreement, subject to the following conditions and limitations:

- (a) Recipient shall have an audit made in accordance with 24 CFR 92.506, THE SINGLE AUDIT ACT OF 1984, 31 U.S.C. 7501 et. seq., and OMB Circular No.133, "AUDITS OF STATES, LOCAL Contract for Home Programs: No Limits IEDC

GOVERNMENTS, AND NON-PROFIT ORGANIZATIONS", for any of its fiscal years included within the Agreement Period, in which Recipient receives more than \$300,000.00 in federal financial assistance provided by a federal agency in the form of grants, contracts, loans, loan guarantees, property, cooperative agreements, interest subsidies, insurance or direct appropriations, but does not include direct federal cash assistance to individuals. The term includes awards of federal financial assistance received directly from federal agencies, or indirectly through other units of State and local government;

- (b) At the option of Recipient, each audit required by this Article may cover either Recipient's entire operations or each department, agency, or establishment of Recipient which received, expended, or otherwise administered federal funds;
- (c) Unless otherwise specifically authorized by City in writing, Recipient shall submit the complete and final report of such audit to City within thirty (30) days after completion of the audit, but no later than one (1) year after the end of each fiscal period included within the period of this Agreement. Audits performed under Subsection A of this Article XX are subject to review and resolution by City or its authorized representative.
- (d) As part of its audit, Recipient shall verify expenditures according to the Budget attached as Exhibit B.

Section 20.02 Notwithstanding Paragraph 20.01 City reserves the right to conduct an annual financial and compliance audit of funds received and performances rendered under this Agreement. Recipient agrees to permit City or its authorized representative to audit Recipient's records and to obtain any documents, materials, or information necessary to facilitate such audit.

Section 20.03 Recipient understands and agrees that it shall be liable to City for any costs disallowed pursuant to financial and compliance audit(s) of funds received under this Agreement. Recipient further understands and agrees that reimbursement to City of such disallowed costs shall be paid by Recipient from funds which were not provided or otherwise made available to Recipient under this Agreement.

Section 20.04 Recipient shall take all necessary actions to facilitate the performance of such audit or audits conducted pursuant to this Article XX as City may require of Recipient.

Section 20.05 All approved HOME audit reports shall be made available for public inspection within 30 days after completion of the audit.

Article XXI. ENVIRONMENTAL CLEARANCE REQUIREMENTS

Section 21.01 Recipient understands and agrees that by the execution of this Agreement, City shall assume the responsibilities for environmental review, decision making, and other action which would otherwise apply to City in accordance with and to the extent specified in 24 CFR, PART 58. In accordance with 24 CFR 58.77(b), Recipient further understands and agrees that City shall handle inquiries and complaints from persons and agencies seeking redress in relation to environmental reviews covered by approved certifications.

Section 21.02 Funds provided under this Agreement may not be obligated and expended before the actions specified in this Article occur.

Section 21.03 City shall prepare and maintain a written Environmental Review Record for this project
Contract for Home Programs: No Limits IEDC

in accordance with 24 CFR PART 58 to ensure compliance with the NATIONAL ENVIRONMENTAL POLICY ACT (NEPA). Recipient must also maintain a copy of the Environmental Review Record in Recipient's project file. City must comply with all other applicable environmental requirements as specified in Exhibit D of this Agreement. City shall document its compliance with such other requirements in its environmental review file.

Article XXII. SPECIAL CONDITIONS

Section 22.01 City shall not release any funds for any costs incurred by Recipient under this Agreement until City has received certification from Recipient that its fiscal control and fund accounting procedures are adequate to assure the proper disbursement and accounting for funds provided under this Agreement. City shall specify the content and form of such certification.

Section 22.02 Affordability. Funds provided under this Agreement must meet the affordability requirement of 24 CFR Part 92 and the HOME rules as applicable. The City shall reduce HOME investment amount to be recaptured on a pro-rata basis for the time the unit is in compliance with 24 CFR 92 and the HOME rules as applicable.

Section 22.03 Repayment. Recipient agrees that all repayments, including all interest and any other return on the investment of HOME funds will be made to City pro-rata. The formula for repayment is the funds received which are subject to repayment divided by the number of months in the period of affordability multiplied by the number of months that a home is not operated in accordance with the affordability requirement.

Section 22.04 Housing Quality Standards. Recipient shall ensure that all housing assisted with funds provided under this Agreement shall meet the requirements of 24 CFR 92.251 for the duration of this Agreement.

Section 22.05 Affirmative Marketing. Should funds from this Agreement be used in the construction of five (5) or more dwelling units, Recipient shall adopt Affirmative Marketing procedures and requirements. The Affirmative Marketing procedures and requirements shall include, but need not be limited to, those specified in 24 CFR 92.351. City will assess the efforts of the Recipient during the marketing of the units by use of compliance certification. Where a Recipient fails to follow the Affirmative Marketing procedures and requirements, corrective actions shall include extensive outreach efforts to appropriate contacts to achieve the occupancy goals or other sanctions the City may deem necessary. Recipient must provide City with an annual assessment of the Affirmative Marketing program of the development, if and Affirmative Marketing program is required under this section. The assessment must include:

- (a) Method used to inform the public and potential residents about Federal Fair Housing laws and Affirmative Marketing policy. Recipient's advertising of housing must include the Equal Housing Opportunity logo or statement. Advertising media may include newspaper, radio, television, brochures, leaflets, or signage. Recipient may wish to use community organizations, places of worship, employment centers, fair housing groups, housing counseling agencies, social service centers or medical service centers as resources for this outreach.
- (b) Records describing actions taken by the Recipient to affirmatively market housing and records to assess the results of these actions. Recipient must maintain a file containing all marketing efforts (i.e. copies of newspaper ads, memos of phone calls, copies of letters) to be available for inspection at least annually by City.

- (c) Recipient shall solicit applications for housing from persons in the housing market who are least likely to apply for housing without benefit of special outreach efforts. In general, persons who are not of the race/ethnicity of the residents of the neighborhood in which the housing is located shall be considered those least likely to apply.
- (d) Recipient shall maintain a listing of all residents residing in each home through the end of the compliance period.
- (e) The Recipient will take all necessary affirmative steps to assure that minority firms, women's business enterprises, and labor surplus area firms are used when possible. Affirmative steps shall include: Placing qualified small and minority businesses and women's business enterprises on solicitation lists; Assuring that small and minority businesses, and women's business enterprises are solicited whenever they are potential sources; Dividing total requirements, when economically feasible, into smaller tasks or quantities to permit maximum participation by small and minority business, and women's business enterprises; Establishing delivery schedules, where the requirement permits, which encourage participation by small and minority business, and women's business enterprises; Using the services and assistance of the Small Business Administration, and the Minority Business Development Agency of the Department of Commerce; and requiring the prime contractor, if subcontracts are to be let, to take the affirmative steps listed in the preceding paragraph.

Section 22.06 Enforcement of Affordability. For each activity assisted under this Agreement, agreements preserving the required affordability period shall be recorded in the real property records of Brazos County.

- (a) **Homebuyer Activities:** For homebuyer activities, City shall provide a legally enforceable agreement consisting of a Real Estate Lien Note and Deed of Trust, containing remedies adequate to enforce the affordability requirements of 24 CFR 92.254. The note and deed of trust will have a term of fifteen (15) years. Funds recaptured because housing no longer meets the affordability requirements under 24 CFR 92.254(a)(5) are subject to the requirements of 24 CFR 92.503.
- (b) **Rental Activities:** For rental activities, City shall provide a legally enforceable Land Use Restriction Agreement (LURA) containing remedies adequate to enforce the affordability requirements of 24 CFR 92.252. The LURA will have a term of twenty (20) years. Funds recaptured because housing no longer meets the affordability requirements under 24 CFR 92.252(e) are subject to the requirements of 24 CFR 92.503.

Section 22.07 Reversion of Assets. Upon termination of this Agreement, all funds remaining on hand on the date of termination and all accounts receivable attributable to the use of funds received under this agreement shall revert to City. Recipient shall return these assets to City within seven (7) days after the date of termination. This section does not refer to CHDO proceeds from the sale of property.

Section 22.08 Flood Hazards. Funds provided under this Agreement may not be used in connection with acquisition, rehabilitation, or construction of a development located in an area identified by the Federal Emergency Management Agency (FEMA) as having special flood hazards.

Section 22.09 Fair Housing. Recipient participating in the HOME program shall use affirmative fair housing marketing practices in determining eligibility and concluding all transactions. These

requirements apply to all projects of five (5) or more units. Each participating entity must affirmatively further fair housing in accordance with 24 CFR 92.350.

Section 22.10 Displacement, Relocation, and Acquisition. Recipient must ensure that it has taken all reasonable steps to minimize the displacement of persons (families, business and nonprofit organizations) as a result of a project assisted with funds provided under this Agreement. Recipient must comply with the applicable provisions of 24 CFR 92.353.

Section 22.11 Property Standards. Recipient shall ensure that all housing assisted with funds provided under this Agreement (1) shall meet the lead-based paint requirements in 24 CFR 92.355 upon project completion and (2) shall meet the requirements of 24 CFR 92.355 for the duration of this Agreement.

Section 22.12 All documents necessary for the conveyance of real property, pursuant to the Agreement, must be approved, prior to execution, by the City. (i.e. deeds, notes, Deed of Trust, leases, etc.)

Section 22.13 Funding under this Agreement is contingent upon Recipient meeting all terms, conditions of this Agreement.

Section 22.14 This Agreement and the performance hereunder may not be assigned without the express written consent of City.

Section 22.15 This Agreement is binding on Recipient's assigns and successors-in-interest.

Article XXIII. ORAL AND WRITTEN CONTRACTS

Section 23.01 All oral and written contracts between the Parties relating to the subject matter of this Agreement that were made prior to the execution of this Agreement have been reduced to writing and are contained in this Agreement.

Section 23.02 The attachments enumerated and denominated below are hereby made a part of this Agreement, and constitute promised performances by Recipient in accordance with Article III of this Agreement.

- | | | |
|-----|------------|---|
| (a) | Exhibit A. | Performance Statement |
| (b) | Exhibit B. | Budget |
| (c) | Exhibit C. | Project Implementation Schedule |
| (d) | Exhibit D. | Applicable Laws and Regulations |
| (e) | Exhibit E. | Certifications |
| (f) | Exhibit F. | Community Development Services Residential Construction Standards |
| (g) | Exhibit G. | Volunteer Release and Indemnification Agreement |

Article XXIV. VENUE

Section 24.01 For purposes of litigation pursuant to this Agreement, venue shall lie in Brazos County, Texas.

Article XXV. COMPLIANCE WITH FEDERAL, STATE AND LOCAL LAWS

Section 25.01 Recipient shall comply with all federal, state and local laws, statutes, ordinances, rules, regulations, orders and decrees of any court or administrative body or tribunal related to the activities and performances of contractor under this Agreement. Upon request by City, Recipient shall furnish satisfactory proof of its compliance herein.

EXECUTED AND EFFECTIVE on this _____ day of _____, 2012.

CITY OF BRYAN

**NO LIMITS INTERNATIONAL
ECONOMIC DEVELOPMENT,
INC.**

Jason P. Bienski, Mayor

Warren Roberts

Warren Roberts, Board President

ATTEST:

Mary Lynne Stratta, City Secretary

APPROVED AS TO FORM:

Janis Hampton, City Attorney

**EXHIBIT A
PERFORMANCE STATEMENT**

NO LIMITS INTERNATIONAL ECONOMIC DEVELOPMENT, INC.

- (1) Award. Recipient is awarded \$70,782.00 from the City of Bryan FY 2012 Budget (\$62,662 FROM HUD GRANT YEAR 2011 AND \$8,120 FROM HUD GRANT YEAR 2010) Community Development Services Department HOME Investment Partnerships Program funds. These funds must be used for: Acquisition and construction of Affordable Housing on the undeveloped property described as Lot 2, Block 199, City of Bryan Townsite, Bryan, Brazos County, Texas, also known as 606 W. 21st St. The home(s) constructed shall be of a design approved by the City.
 - (2) Design and Construction.
 - a. Exterior construction shall consist of a minimum of 25% brick or stone veneer, with any remainder being fiber-cement siding. The brick portion will either be on the entire front of the home, or may be applied in wainscot fashion around the complete exterior, with the brick or stone veneer extending from the slab up to a reasonable and aesthetically appropriate height. Recipient shall submit final plans and specifications to the City's Community Development Services Department.
 - b. In addition to meeting minimum code requirements, the following features shall be installed:
 - i. AS SPECIFIED IN RESPONSE TO RFP #12-032
 - ii. Storage structure, garage, or exterior-access storage room with a minimum unobstructed open area of 80 square feet.
 - c. Preconstruction Conference Required: At least ten (10) days prior to applying for a building permit, Recipient shall attend a preconstruction conference with the City of Bryan Community Development Services Department to discuss the following issues:
 - i. Plans and Specifications Preview
 - ii. Press Release and Signage
 - iii. Draw Procedures
 - (3) Substantially as in Response to RFP. Uses of funds, design, and construction, and all other elements of the project shall be to accomplish the development and sale or lease of property to income-eligible households, substantially as submitted by the CHDO in the Proposal submitted in response to the City of Bryan Request for Competitive Sealed Proposals RFP #12-032.
 - (4) Codes. All work must be in compliance with current City of Bryan Building Codes. All required permits must be obtained prior to any work commencing. All required inspections must be performed by the City of Bryan Building Inspectors.
 - (5) Easements. Recipient shall dedicate any easements required by City including blanket easements which shall be substituted with as-built easements for all City utilities.
 - (6) Recipient must provide written notification of all subcontractors to City on the Subcontractor Utilization Report form with all required subcontractor information, and required information on program participants.
- Contract for Home Programs: No Limits IEDC Page 15 of 28

- (7) Completion. The project must be substantially completed within one (1) year of the date of this contract. Upon completion of such construction Recipient must submit a copy of all receipts paid for the work associated with this contract. At that point, the City will have 30 days to make payment on said receipts, not to exceed maximums established in Exhibit B, Budgets.
- (8) Occupancy. Within six (6) months from issuance of the Certificate of Occupancy, said HOME unit must be occupied by an eligible resident. Recipient is not prohibited from conducting background check on credit history or criminal history.
- (9) Recapture, Repayment, Program Income, and Project Proceeds. Income does not constitute program income, recaptured funds, or repayment of funds. However, any program income, recaptured funds, repaid funds, or repayment of any funds must be immediately returned to the City of Bryan Community Development Services Department - HOME Investment Partnerships Program. The City grants the Recipient the authority for the right to maintain all project proceeds. Any/All program income, recaptured funds, repaid funds, project proceeds, etc., are subject to this contract.

**EXHIBIT B
BUDGET**

NO LIMITS INTERNATIONAL ECONOMIC DEVELOPMENT, INC.

SOURCES OF FUNDS:

Maximum Proceeds of Grant Under the Contract	\$70,782.00
--	-------------

USES OF FUNDS:

Eligible Acquisition and Construction Costs	\$ 63,703.80
Maximum Program Delivery Expense (10% of Proceeds)	\$ 7,078.20

EXHIBIT C

PROJECT IMPLEMENTATION SCHEDULE

CONTRACT START DATE: August 28, 2012

CONTRACT END DATE: August 27, 2014

Acquisition Phase – Acquisition of the property shall be completed by September 28, 2012.

Pre-Construction Phase – Pre-construction survey, title, and design activities shall be completed by December 31, 2012.

Construction Phase – Construction for this project is scheduled to begin no later than January 1, 2013, with completion, certificate of occupancy, and final reimbursement draw request date no later than August 27, 2014. The issuance of a building permit will constitute start of construction.

Marketing and Occupancy – Marketing of the completed project will begin no later than the date of issuance of the Certificate of Occupancy. Placement of a print advertisement in Bryan-College Station Eagle newspaper or a listing in the Bryan College Station Regional Association of Realtors Multiple Listing Service shall constitute the initiation of marketing. Occupancy of the completed project by a qualified homebuyer or renter household shall be within six months of the issuance of the Certificate of Occupancy.

EXHIBIT D

THE APPLICABLE LAWS AND REGULATIONS

Recipient shall comply with all federal, state, and local laws and regulations applicable to the activities and performances rendered by Recipient under this contract including but not limited to the laws, and the regulations specified in Section I through VI of this Exhibit D.

I. CIVIL RIGHTS

THE FAIR HOUSING ACT (42 U.S.C. 3601-20) AND IMPLEMENTING REGULATIONS AT 24 CFR PART 100; EXECUTIVE ORDER 11063, AS AMENDED BY EXECUTIVE ORDER 12259 (3 CFR, 1958-1963 COMP., P. 652 AND 3 CFR, 1980 COMP., P. 307) (EQUAL OPPORTUNITY IN HOUSING) AND IMPLEMENTING REGULATIONS AT 24 CFR, PART 107; AND TITLE VI OF THE CIVIL RIGHTS ACT OF 1964 (42 U.S.C. 2000D) (NONDISCRIMINATION IN FEDERALLY ASSISTED PROGRAMS) AND IMPLEMENTING REGULATIONS ISSUED AT 24 CFR, PART 1;

EXECUTIVE ORDER 11063, AS AMENDED BY EXECUTIVE ORDER 12259, AND 24 CFR PART 107, "NONDISCRIMINATION AND EQUAL OPPORTUNITY IN HOUSING UNDER EXECUTIVE ORDER 11063". THE FAILURE OR REFUSAL OF RECIPIENT TO COMPLY WITH THE REQUIREMENTS OF EXECUTIVE ORDER 11063 OR 24 CFR, PART 107 SHALL BE A PROPER BASIS FOR THE IMPOSITION OF SANCTIONS SPECIFIED IN 24 CFR 107.60;

THE PROHIBITION AGAINST DISCRIMINATION ON THE BASIS OF AGE UNDER THE AGE DISCRIMINATION ACT OF 1975 (42 U.S.C. 6101-07) AND IMPLEMENTING REGULATIONS AT 24 CFR, PART 146, AND THE PROHIBITIONS AGAINST DISCRIMINATION AGAINST HANDICAPPED INDIVIDUALS UNDER SECTION 504 OF THE REHABILITATION ACT OF 1973 (29 U.S.C. 794) AND IMPLEMENTING REGULATIONS AT 24 CFR, PART 8;

THE PROHIBITION AGAINST DISCRIMINATION ON THE BASIS OF SEXUAL ORIENTATION OR GENDER IDENTITY BY HUD POLICY RULE AS PUBLISHED IN FR-5359.

THE REQUIREMENTS OF EXECUTIVE ORDER 11246 (3 CFR 1964-65, COMP., P. 339) (EQUAL EMPLOYMENT OPPORTUNITY) AND THE IMPLEMENTING REGULATIONS ISSUED AT 41 CFR, CHAPTER 60.

THE REQUIREMENTS OF 24 CFR 92.351 (MINORITY OUTREACH), EXECUTIVE ORDERS 11625 AND 12432 (CONCERNING MINORITY BUSINESS ENTERPRISE), AND 12138 (CONCERNING WOMEN'S BUSINESS ENTERPRISE). CONSISTENT WITH HUD'S RESPONSIBILITIES UNDER THESE ORDERS, RECIPIENT MUST MAKE EFFORTS TO ENCOURAGE THE USE OF MINORITY AND WOMEN'S BUSINESS ENTERPRISES IN CONNECTION WITH HOME FUNDED ACTIVITIES. RECIPIENT MUST PRESCRIBE PROCEDURES ACCEPTABLE TO THE CITY TO ESTABLISH ACTIVITIES TO ENSURE THE INCLUSION, TO THE MAXIMUM EXTENT POSSIBLE, OF MINORITIES AND WOMEN, AND ENTITIES OWNED BY MINORITIES AND WOMEN. THE CONTRACTOR / SUBCONTRACTOR WILL BE REQUIRED TO IDENTIFY CONTRACTS WHICH HAVE BEEN BID BY MINORITY OWNED, WOMEN OWNED, AND/OR SMALL DISADVANTAGED BUSINESSES.

THE AGE DISCRIMINATION ACT OF 1975 (42 U.S.C., SECTION 6101 ET SEQ.);

SECTION 504 OF THE REHABILITATION ACT OF 1973 (29 U.S.C., SECTION 794) AND "NONDISCRIMINATION BASED ON HANDICAP IN FEDERALLY-ASSISTED PROGRAMS AND

ACTIVITIES OF THE DEPARTMENT OF HOUSING AND URBAN DEVELOPMENT", 24 CFR, PART 8. BY SIGNING THIS CONTRACT, RECIPIENT UNDERSTANDS AND AGREES THAT THE ACTIVITIES FUNDED HEREIN SHALL BE OPERATED IN ACCORDANCE WITH 24 CFR, PART 8; AND THE ARCHITECTURAL BARRIERS ACT OF 1968 (42 U.S.C., SECTION 4151 ET. SEQ.) INCLUDING THE USE OF A TELECOMMUNICATIONS DEVICE FOR DEAF PERSONS (TDDs) OR EQUALLY EFFECTIVE COMMUNICATION SYSTEM.

SECTION 3 OF THE HOUSING AND URBAN DEVELOPMENT ACT OF 1968(24 CFR PART 135.38) CHDO'S ARE ENCOURAGED, TO THE GREATEST EXTENT FEASIBLE, TO PROVIDE OPPORTUNITIES FOR TRAINING AND EMPLOYMENT FOR LOWER INCOME RESIDENTS AND BUSINESSES OF THE PROJECT AREA.

PATENT AND COPYRIGHT INFRINGEMENT NOTICE: SERVICE PROVIDER SHALL COMPLY WITH REGULATIONS PERTAINING TO COPYRIGHTS AND RIGHTS IN DATA AND REQUIREMENTS PERTAINING TO PATENT RIGHTS WITH RESPECT TO ANY DISCOVERY OR INVENTION WHICH ARISES OR IS DEVELOPED IN THE COURSE OF OR UNDER SUCH CONTRACT.

II. LEAD-BASED PAINT

TITLE IV OF THE LEAD-BASED PAINT POISONING PREVENTION ACT (42 U.S.C. SEC. 4831).

III. ENVIRONMENTAL STANDARDS

NATIONAL ENVIRONMENTAL POLICY ACT OF 1969 (42 U.S.C. SEC. 4321 ET. SEQ.) AND 40 CFR PARTS 1500-1508;

THE NATIONAL HISTORIC PRESERVATION ACT OF 1966 (16 U.S.C. SEC. 470 ET. SEQ.) AS AMENDED; PARTICULARLY SECTION 106 (16 U.S.C. SEC. 470F);

EXECUTIVE ORDER 11593, PROTECTION AND ENHANCEMENT OF THE CULTURAL ENVIRONMENT, MAY 13, 1971 (36 FED. REG. 8921), PARTICULARLY SECTION 2(C);

THE RESERVOIR SALVAGE ACT OF 1960 (16 U.S.C. SEC. 469 ET SEQ.). PARTICULARLY SECTION 3 (16 U.S.C. SEC. 469A-1), AS AMENDED BY THE ARCHEOLOGICAL AND HISTORIC PRESERVATION ACT OF 1974; FLOOD DISASTER PROTECTION ACT OF 1973, (42 U.S.C. SEC. 4001 ET. SEQ.) AS AMENDED, PARTICULARLY SECTIONS 102(A) AND 202(A) (42 U.S.C. SEC. 4012A (A) AND SEC. 4106(A);

EXECUTIVE ORDER 11988, FLOODPLAIN MANAGEMENT, MAY 24, 1977 (42 FED. REG. 26951), PARTICULARLY SECTION 2(A).

EXECUTIVE ORDER 11990 PROTECTION OF WETLANDS, MAY 24, 1977 (42 FED. REG. 26961), PARTICULARLY SECTIONS 2 AND 5.

THE SAFE DRINKING WATER ACT OF 1974, (42 U.S.C. SEC. 201, 300(F) ET SEQ.) AND (21 U.S.C. SEC. 349) AS AMENDED, PARTICULARLY SECTION 1424(E) (42 U.S.C. SEC. 300H-303(E);

THE ENDANGERED SPECIES ACT OF 1973, (16 U.S.C. SEC. 1531 ET. SQ.) AS AMENDED, PARTICULARLY SECTION 7 (16 U.S.C. SEC. 1536);

THE WILD AND SCENIC RIVERS ACT OF 1968, (16 U.S.C. SEC. 1271 ET SEQ.) AS AMENDED, PARTICULARLY SECTION 7(B) AND (C) (16 U.S.C. SEC. 1278 (B) AND (C));

THE CLEAN AIR ACT (41 U.S.C. SEC. 7401 ET SEQ.) AS AMENDED, PARTICULARLY SECTION 176(C) AND (D) (42 U.S.C. SEC. 7506 (C) AND (D));

FARMLANDS PROTECTION AND POLICY ACT OF 1981, (7 U.S.C. SEC. 4201 ET SEQ.)

24 CFR PART 51, ENVIRONMENTAL CRITERIA AND STANDARDS.

IV. ACQUISITION/RELOCATION

THE UNIFORM RELOCATION ASSISTANCE AND REAL PROPERTY ACQUISITION POLICIES ACT OF 1970 (42 U.S.C., SEC. 4601 ET. SEQ.), 49 CFR PART 24, AND 24 CFR SECTION 570.496A (55 FED. REG. 29309 (JULY 18, 1990)

ANTI-DRUG ABUSE ACT OF 1988 (42 U.S.C. 11901 ET. SEQ.) REGARDING TERMINATION OF TENANCIES FOR DRUG RELATED OFFENSES IN ASSISTED HOUSING.

V. LABOR REQUIREMENTS

CONTRACT WORK HOURS AND SAFETY STANDARDS ACT, AS AMENDED (40 USC 327-333), COPELAND (ANTI-KICKBACK) ACT (40 USC 276C), FAIR LABOR STANDARDS ACT OF 1938, AS AMENDED (29 USC 201, ET. SEQ.), AND DAVIS-BACON AND RELATED ACTS (40 USC 276(A)-7) (12 OR MORE UNITS ONLY).

EMPLOYMENT OF CERTAIN PERSONS PROHIBITED: NO PERSON UNDER THE AGE OF SIXTEEN YEARS AND NO PERSON WHO, AT THE TIME, IS SERVING SENTENCE IN A PENAL OR CORRECTIONAL INSTITUTION SHALL BE EMPLOYED IN THE WORK OF THIS PROJECT.

H.B. 275, THE TEXAS PROMPT PAYMENT ACT: SERVICE PROVIDER SHALL COMPLY WITH THE TEXAS PROMPT PAYMENT ACT, EFFECTIVE JULY 1, 1986, WHICH IN PART, REQUIRES THE SERVICE PROVIDER TO PAY THEIR SUBCONTRACTORS WITHIN TEN (10) CALENDARS DAYS AFTER THEY RECEIVE PAYMENT FROM THE CITY OF BRYAN.

EXHIBIT E

**CERTIFICATION REGARDING LOBBYING FOR
CONTRACTS, GRANTS, LOANS, AND COOPERATIVE AGREEMENTS**

The undersigned certified, to the best of its knowledge and belief, that:

1. No federal appropriated funds have been paid or will be paid, by or on behalf of the undersigned, to any person for influencing or attempting to influence an officer or employee of an agency, a member of congress, an officer or employee of congress, or an employee of a member of congress in connection with the awarding of any federal contract, the making of any federal grant, the making of any federal loan, the entering into of any cooperative agreement or modification of any federal contract, grant, loan, or cooperative agreement.
2. If any funds other than federal appropriated funds have been paid or will be paid to any person for influencing or attempting to influence an officer or employee of any agency, a member of congress, an officer or employee of congress, or an employee of a member of congress in connection with this federal contract, grant, loan, or cooperative agreement, the undersigned shall complete and submit standard form LLL, "Disclosure Form to Report Lobbying", in accordance with its instructions.

The undersigned shall require that the language of this certification be included in the award documents for all sub-awards at all tiers (including subcontracts, sub-grants, and contracts under grants, loans, and cooperative agreements) and that all sub recipients shall certify and disclose accordingly.

This certification is material representation of fact which reliance was placed when this transaction was made or entered into. Submission of this certification is a prerequisite for making or entering into this transaction imposed by section 1352, Title 31, U.S. Code. Any person who fails to file the required certification shall be subject to a civil penalty of not less than \$10,000 and not more than \$100,000 for each such failure.

Signed: BY: Warren Roberts
Warren Roberts, Board President
No Limits International Economic Development, Inc.

DATE: _____

Exhibit F

CITY OF BRYAN
COMMUNITY DEVELOPMENT SERVICES
RESIDENTIAL CONSTRUCTION STANDARDS

I. GENERAL

- a. All standards listed herein that are in conflict with applicable City ordinances and/or building codes, shall be rejected and the applicable development standards shall prevail if more restrictive. All standards listed herein that are in conflict with applicable property deed restrictions, shall be rejected and the applicable property deed restrictions shall prevail if more restrictive.
- b. These Residential Building Development Standards are the City of Bryan's basic minimum standards by which a residential structure may be approved for development.
- c. Any conflict between these standards and the City's codes and ordinances shall be brought to the attention of the Community Development Services Department.

II. SITE

- a. Building foundation finished grade shall be formed to a minimum of 6" higher than the highest point of existing topographical gradient within the building footprint. In the cases where a building is constructed partially or completely in a flood plain, applicable national building standards for building in a flood plain shall prevail.
- b. Finished grade around the building perimeter shall be a minimum of 4" below brick ledge or bottom of siding, and all site grading shall be manipulated and sloped to move water away from building foundation, and towards a natural flow drainage area. Site drainage grading shall meet the approval of the City's Drainage Engineer.
- c. All yard area shall be sodded or hydro-seeded with Bermuda grass (native to Brazos Valley area climate) and kept alive and maintained until the house is conveyed to a qualified buyer.
- d. A minimum of one - 2" diameter tree (native to Brazos Valley area climate) shall be placed in the front yard and kept alive and maintained until the house is conveyed to a qualified buyer.
- e. Sanitary sewer, water, gas and rainwater drainage utility service lines shall be buried at minimum bury depths in accordance with applicable City codes and ordinances. Aerial phone, cable and electrical utility service lines shall be installed at heights that comply with City codes and ordinances and shall not interfere with typical equipment common to residential neighborhoods.

- f. Site plantings of trees, bushes and shrubs shall be installed in accordance with applicable City codes and ordinances, and shall not obstruct traffic vision of neighborhood driveways and pedestrians.
- g. If property landscape development is regulated by deed restrictions, deed restrictions shall prevail.

III. FOUNDATION

- a. Foundations shall be constructed in compliance with the most currently adopted City residential building codes and ordinances. However, it is a good practice for an engineer to design foundation plans and details based upon the soil beneath the foundation, and the loads that will be imposed upon the foundation.
- b. Foundation footprints shall be established within the property building set-back lines, unless a variance has been requested and granted by the appropriate City board or commission prior to construction. City staff may not always support a contractor/developer variance request, but reasons regarding staff opposition to the variance shall be explained to the contractor/developer prior to the variance hearing.
- c. Recessed brick ledges shall be installed at all exterior masonry veneer locations. No recessed brick ledge shall be installed in areas where siding is used at the base of the exterior wall.
- d. No block and pad pier and beam-type foundations shall be allowed on new construction homes. Architect and/or engineer-approved drilled pier foundations may be used.

IV. EXTERIOR BUILDING ENVELOPE

- a. Builders are encouraged to incorporate the City of Bryan and Bryan Texas Utilities Green Plus energy rebate program into their home design.
- b. Exterior wall area shall be composed of a minimum of 25% brick, stone or stucco veneer. Remaining exterior wall area shall be composed of Hardie® brand lap siding or an equivalent product in material composition to the Hardie® brand.
- c. Exterior walls shall be rated at R-13 minimum and the attic space shall be rated at R-30 as per City codes.
- d. Windows shall be double insulated, low-E designed windows that comply and are installed in accordance with the currently adopted International Energy Conservation Code, and shall be sized in accordance with the International Residential Code for emergency egress.
- e. Exterior doors shall be six-panel, metal insulated, foam core doors. Front and rear doors may have a half-moon window or other door top window which is out of reach of the door locks for security purposes. A peep-hole shall be installed in front door if a solid front door is selected. All exterior doors shall be weather-stripped, pre-hung units with one of the doors (preferably front) required to be a 3068 door.

- f. Exterior wall sheathing shall be 7/16" OSB or 1/2" plywood, covered with IECC recommended house wrap, spliced, taped and appropriately folded and sealed into exterior wall openings, and all wall penetrations properly sealed.
- g. All pipe penetrations through the exterior walls shall be sleeved with steel pipe or galvanized sleeves the thickness of the penetrated areas, and penetrate as close to the equipment as possible, or as low as possible for proper discharge. No pipes or HVAC line-sets shall run down the brick face to equipment, or covered with a shroud. All gaps between sleeves and pipes shall be filled with latex caulk to match as close as possible the color of the brick grout. Expanding foam may also be used, but foam or caulk shall have smooth finish with sleeve opening NO BEADS OR PROTRUSIONS.
- h. All exterior wall bottom plates shall be wolmanized treated 2" x 4" nominal sized #2 southern yellow pine lumber material. All exterior wall studs shall be #2 kiln-dried southern yellow pine lumber material. Top plates shall be 2" x 4" nominal sized southern yellow pine lumber material. Multi-story homes shall use nominally sized southern pine lumber material and/or engineered laminated products sized to the support load.
- i. Soffits shall be constructed of HardieSoffit® brand perforated soffit, and all exterior brick frieze and trim materials shall be HardieTrim® brand materials (or approved equals).
- j. Roof sheathing shall be 15/32" Georgia Pacific Plytanium® Thermostat® plywood radiant barrier sheathing or an approved equal. Foil face side of the sheathing shall face attic.
- k. Roof sheathing shall be covered with at least 15# roofing felt. Galvanized D-drip edge shall be installed around roof edge perimeter. A ridge vent and a minimum of one wind turbine shall be installed as per manufacturer's recommendations on the roof sheathing prior to felt coverage. All roof pipe and metal vent penetrations shall be appropriately flashed, collared, capped and sealed prior to roof felt coverage. Roof shingles shall be 30-year architectural dimensional shingles with a light, neutral color to reflect heat.
- l. Exterior siding and trim cracks, seams and joints shall be caulked with an exterior 30 year latex caulk, and all exterior paint surfaces shall be primed and painted with a minimum of two coats durable exterior acrylic latex paint carrying a 30 year or more warranty.
- m. Front porches, rear porches and stoops shall be designed to provide ample cover and protection from inclement weather for the occupants opening the exterior doors.
- n. A 15-1/4" x 9-1/4" limestone address block with black numbers shall be installed in a conspicuous location on the front of the house, easily observed from the frontage street if a solid front brick, stone or stucco veneer is used. If siding is used on the front of the structure, a decorative brass address house plate (or approved equal) with minimum of 4" numbers shall be installed, and located as stated above.
- o. A lighted doorbell shall be installed at the front door location.
- p. Exterior decorative lights shall be installed at all exterior door locations and a front and rear 2-way flood light shall be installed under soffit corners to illumine the front, rear and side yards for security. Flood lights shall also be switched at nearest exterior door locations for easy access.

V. INTERIOR

- a. Structure shall be a minimum of 1,000 square feet of conditioned air space, or, upon approval of the City, may be smaller to accommodate lot requirements or the space needs and affordability requirements of the household.
- b. Single Family structures shall be a minimum of 2 bedrooms, 1-1/2 baths.
- c. Structure shall have a minimum of a one car garage or carport (unobstructed open space of 10' W x 20' L). In lieu of the garage, a storage structure or storage room may be substituted with a minimum unobstructed open area of 80 square feet and six foot width.
- d. Structure shall be equipped with a name brand HVAC split-system or heat pump, sized in accordance with applicable codes and carrying a minimum of 13 SEER rating.
- e. All interior walls shall be framed with 2" x 4" nominal size Temple® brand #2 southern yellow pine studs (or equal), with wolmanized sole plates and double top plates. Ceiling joists and rafters shall be sized in accordance with City codes and ordinances. Wet walls shall be sized to accommodate piping holes and notches in accordance with City codes and ordinances. Blocking shall be installed securely at all cabinetry and hardware locations.
- f. A folding attic stair or scuttle hole shall be installed in garage or hallway, sized to accommodate the replacement of largest equipment to be serviced in the attic space.
- g. All plumbing faucets and valves shall be builder grade or better, and finish of faucets and valves shall match finish of electrical fixtures and hardware in bathrooms and kitchen areas.
- h. All bedrooms and living room shall be equipped with cable TV and telephone jacks.
- i. Appliance spaces shall be Energy Star-rated, and mechanically fitted to receive either gas or electrical appliances at the stove, oven, water heater, dryer and air handler locations.
- j. An icemaker stop or recessed box shall be supplied to all refrigerator or ice maker locations.
- k. All vent-a-hoods requiring ducts shall be vented through the roof. Charcoal filter, non-vented vent-a-hoods are permissible.
- l. Kitchen sinks shall be a minimum of satin finish, stainless steel double basin, seven inches (7") deep with a one-half (1/2") horsepower food disposer.
- m. Flooring materials shall be strong and durable products carrying a minimum of 15 year warranty. Flooring products containing recycled materials are preferred. No long shag carpet shall be allowed. Ceramic tile or vinyl flooring is required in all wet areas.

- n. Exterior mounted instantaneous gas water heaters are preferred, but if not used, a well-insulated Energy Star rated 40 gallon tank heater is the required minimum.
- o. Dryers shall be vented out a side wall only...no venting upwards is allowed.
- p. Ceilings shall be a minimum of 8' (designed 9' vaulted, boxed or chamfered ceilings are encouraged).
- q. All bedroom and bathroom doors shall have minimum of KwikSet Valiant (equal or better) privacy knobs, closets shall have passage knobs, and exterior doors shall be keyed alike and equipped with a keyed entry knob and a keyed entry-single cylinder deadbolt lock.
- r. Kitchen counter tops shall be minimum quality of Wilson Art laminated plywood countertops with 4" or rolled backsplash. No pre-formed countertops shall be allowed.
- s. All bath lavatories, vanities, tub/shower and shower units shall be at minimum Lasco Fiberglass units or better.
- t. All kitchen and bath cabinetry units shall be, at minimum, Leedo Oakview units.
- u. Energy Star rated ceiling fans shall be installed in all bedrooms and living area.
- v. Hard-wired smoke detectors, wired in series, shall be installed in accordance to City codes. All smoke detectors shall sound off when one is activated.

EXHIBIT G

VOLUNTEER RELEASE AND INDEMNIFICATION AGREEMENT

I, _____, a volunteer work group member of _____ (Print Name)

_____, a Texas, Non-Profit Corporation, will be providing _____ (Non-Profit Agency)

Volunteer labor on the dwelling located at _____, Bryan, Brazos County, Texas. (Property Address)

I, THE UNDERSIGNED agree to and shall indemnify and hold harmless THE CITY OF BRYAN, its public officials, officers, agents and employees from and against any and all claims, losses, demands, judgments and causes of action of every kind and character including reasonable attorney fees, costs and expert fees, which may be asserted by any third party occurring or in any way incident to, arising out of, or in connection with the services and work to be performed. I understand that the City of Bryan is not responsible for the work being conducted on this project. I understand that the labor may involve a risk of injury to myself or others, and that the City of Bryan is not responsible for those risks nor does the City have any duty to mitigate those risks or make me aware of same. I understand that the City does not waive its governmental immunity, the limitations as to damages contained in the Texas Tort Claims Act or consent to suit. I hereby waive any claim I may have now, or that may arise in the future, against the City of Bryan arising out of or in connection with the services and work to be performed.

Signature of Volunteer Participant Date

Printed Name of Volunteer Participant TX Driver's License or ID # (Required)

Home Address # Street City State Zip

Phone # Email

**CONTRACT FOR
HOME PROGRAMS
Community Housing Development Organization**

Article I. PARTIES

Section 1.01 This HOME Investment Partnerships Program (HOME) Community Housing Development Organization (CHDO) Contract for HOME Programs (the "Contract") is between the **City of Bryan** ("City"), a political subdivision of the State of Texas, and, **No Limits International Economic Development, Inc.**, ("Recipient"), a Texas Non-Profit Corporation (collectively referred to herein as the "Parties").

Article II. CONTRACT PERIOD

Section 2.01 This Agreement shall commence when executed by all parties and terminate on August 27, 2014, unless extended by agreement of the Parties in writing.

Article III. RECIPIENT PERFORMANCE

Section 3.01 Recipient shall act in the role of Non-Profit Owner and Developer of affordable single-family homebuyer or rental housing in accordance with the HOME INVESTMENT PARTNERSHIPS ACT OF 1990, 42 U.S.C. 12701 ET SEQ. (THE ACT) and the implementing regulations, 24 CFR PART 92, TEXAS LOCAL GOVERNMENT CODE SECTION 373.001 ET SEQ., and the HOME INVESTMENT PARTNERSHIPS PROGRAM RULES. Recipient shall perform all activities in accordance with the terms of the Performance Statement, ("Exhibit A" attached hereto); the Budget, ("Exhibit B" attached hereto); the Project Implementation Schedule, ("Exhibit C" attached hereto); the Applicable Laws and Regulations, ("Exhibit D" attached hereto); the Certifications, ("Exhibit E" attached hereto); the Community Development Services Residential Construction Standards ("Exhibit F" attached hereto), Volunteer Release and Indemnification Agreement ("Exhibit G" attached hereto), the Land Use Restriction Agreement for rental developments ("Exhibit H" attached hereto) the assurances, covenants, warranties, certifications, and all other statements made by Recipient in its application for the project funded under this Agreement; and with all other terms, provisions, and requirements set forth in this Agreement.

Section 3.02 Recipient shall perform all activities in the Performance Statement within two (2) years of date of execution of this Agreement.

Section 3.03 In the event the affordability requirements of 24 CFR Part 92 are not satisfied by Recipient hereunder, Recipient shall bear ultimate responsibility for repayment of HOME funds.

Section 3.04 In the event that there is program income, repayments, and/or recaptured funds, the funds must be used in accordance with the requirements of 24 CFR 92.503, as outlined in the Performance Statement, "Exhibit A".

Section 3.05 Recipient agrees to maintain itself as a CHDO in accordance with Title II of the National Affordable Housing Act (1990), as it may be amended, concerning the HOME Investment Partnership program (HOME) and 24 CFR 92.300.

Section 3.06 Recipient agrees that all applicants for housing funded under this agreement will be initially qualified and approved by the City of Bryan Community Development Services Department.

Section 3.07 Recipient Insurance Recipient agrees to obtain and maintain, at a minimum, the insurance coverage, endorsements, and limits as set forth below for the duration of the contract:

- (a) **Workers' Compensation Insurance & Employers' Liability Insurance** – Statutory & \$500,000/\$500,000/\$500,000. Recipient agrees to maintain Worker's Compensation Insurance & Employers Liability. Waiver of subrogation in favor of the City required. This requirement may be waived with satisfactory evidence that the Recipient is a sole proprietor(s) having no employees and/or has no employees working on this construction project. This requirement may also be waived for volunteers with a signed Volunteer Release and Indemnification Agreement.
- (b) **Commercial General Liability Insurance** – Limit of liability not less than \$500,000 per occurrence. Recipient agrees to maintain a standard ISO version Commercial General Liability occurrence form, or its equivalent providing coverage for, but not limited to, Bodily Injury and Property Damage, Premises/Operations, Products/Completed Operations, Independent Contractors. Additional insured endorsement required.
- (c) **BUILDER'S RISK** – Limit not less than 100% of the total projected construction value at completion of the project. Recipient agrees to maintain Builder's Risk insurance providing coverage to protect the interests of the City, Recipient, sub-contractors, including property in transit and property on or off-premises, which shall become a part of the building or project. Coverage shall be written on an All-Risk, Replacement Cost, and Completed Value Form basis. Loss Payee endorsement required. This requirement may be waived with satisfactory evidence that the Recipient has contracted for all construction activities, and the contractor and subcontractors have obtained the required insurance policies and coverage.

Section 3.08 The Recipient shall include, in addition to provisions to define a sound and complete agreement, the following provisions in all contracts as specified:

- (a) For those contracts or subcontracts which exceed \$25,000, a payment bond on the part of the contractor or subcontractor shall be issued for the protection of the CHDO for 100 percent of the contract or subcontract price.
- (b) For those contracts or subcontracts which exceed \$100,000, a performance bond on the part of the contractor or subcontractor shall be issued for the protection of the City of Bryan in the amount of the contract or subcontract, conditioned on the faithful performance of the work in accordance with the plans, specifications, and contract documents.
- (c) Contractor agrees to obtain and maintain the insurance coverage, endorsements, and limit as set forth below for the duration of the contract:
 - (a) **Workers' Compensation Insurance & Employers' Liability Insurance** – Statutory & \$500,000/\$500,000/\$500,000. Contractor agrees to maintain Worker's Compensation Insurance & Employers Liability. In the event any work is sublet, the Contractor shall require the subcontractor similarly to provide the same coverage and shall himself acquire evidence of such coverage on behalf of the subcontractor. Waiver of subrogation in favor of the CHDO required. This requirement may be waived with satisfactory evidence that the contractor is a sole proprietor(s) having no employees.
 - (b) **Commercial General Liability Insurance** – Limit of liability not less than \$500,000 per occurrence. Contractor agrees to maintain a standard ISO version Commercial General Liability occurrence form, or its equivalent providing coverage for, but not limited to, Bodily Injury and Property Damage, Premises/Operations, Products/Completed

Operations, Independent Contractors. Additional insured endorsement naming the Recipient is required.

Article IV. CITY OBLIGATIONS

Section 4.01 Measure of Liability. In consideration of full and satisfactory performance of the activities referred to in Article V of this Agreement, City shall be liable for actual and reasonable costs incurred by Recipient during the Agreement period for performances rendered under this Agreement by Recipient, subject to the limitations set forth in this Article IV.

- (a) The Parties agree that City's obligations to meet City's liabilities under Article IV of this Agreement are contingent upon the actual receipt of adequate local and/or federal funds. If adequate funds are not available to make payments under this Agreement, City shall notify Recipient in writing within a reasonable time after such fact is determined. City shall then terminate this Agreement and shall not be liable for failure to make payments to Recipient under this Agreement.
- (b) City shall not be liable to Recipient for any costs incurred by Recipient, or any portion thereof, which have been paid to Recipient or which are subject to payment to Recipient, or which have been reimbursed to Recipient, or are subject to reimbursement to Recipient, by any source other than City or Recipient.
- (c) City shall not be liable to Recipient for any costs incurred by Recipient which are not eligible project costs, as set forth in 24 CFR 92.206(A) and Article VI of this Agreement. Funds provided under this Agreement shall not be used nor shall City be liable for payment of costs associated directly or indirectly incurred because of prohibited activities as defined in 24 CFR 92.214.
- (d) City shall not be liable to Recipient for any costs incurred by Recipient or for any performances rendered by Recipient which are not strictly in accordance with the terms of this Agreement, including the terms of Exhibits A, B, C, D, E F and G of this Agreement.
- (e) City shall not be liable for costs incurred or performance rendered by Recipient before commencement or after termination of this Agreement.

Section 4.02 LIMIT OF LIABILITY. NOTWITHSTANDING ANY OTHER PROVISION OF THIS AGREEMENT, THE TOTAL OF ALL PAYMENTS AND OTHER OBLIGATIONS INCURRED BY CITY UNDER THIS AGREEMENT SHALL UNDER NO CIRCUMSTANCES EXCEED SEVENTY THOUSAND, SEVEN HUNDRED EIGHTY-TWO AND NO/100, (\$70,782.00), FROM THE FY 2012 BUDGET (\$62,662 FROM HUD GRANT YEAR 2011 AND \$8,120 FROM HUD GRANT YEAR 2010).

Article V. DISBURSEMENT OF FUNDS

Section 5.01 City shall pay costs incurred which it determines are eligible and which are properly submitted under this Agreement in accordance with the requirements of 24 CFR 92.502. Recipient may not request disbursement of funds under this Agreement until the funds are needed for payment of eligible costs. The amount of each request must be limited to the amount of money needed to pay eligible costs actually incurred, and may not include amounts for prospective or future needs. Reimbursement requests shall contain an itemization of each expense item, and documentation, including paid receipts, invoices, signed draw requests, signed change orders, and canceled checks. Recipient may use up to ten percent (10%) of the grant amount for eligible program delivery expenses but in no case shall program delivery

expenses exceed 10% of the project cost or funded amount, whichever is less, as determined by the City. These costs may include but are not limited to: Architectural, engineering or related professional services required to prepare plans, drawings, specifications, or work write-ups, costs to process and settle financing, such as private lender origination fees, credit reports, fees for title evidence, fees for recordation and filing of legal documents, building permits, impact fees, attorney's fees, private appraisal fees and fees for an independent cost estimate, builders or developers fees, staff and overhead costs directly related to carrying out the project, such as work specifications preparation, loan processing inspections, and other services related to assisting potential owners, tenants, and homebuyers. General administrative expenses of the CHDO are not eligible program delivery expenses.

Section 5.02 Any and all Program Income as defined by 24 CFR 84.2 must be disbursed by Recipient prior to requesting a disbursement of funds from the City. CHDO proceeds from the sale of properties developed under this agreement are not to be considered program income but may be retained by the CHDO as allowed under 24 CFR 92.300(a)(2), however, all such proceeds must be used for future HOME-eligible projects within the jurisdictional boundaries of the City of Bryan.

Section 5.03 The Parties agree that City's obligations to make payments under this Agreement are contingent upon Recipient's full and satisfactory performance of its obligations under this Agreement. City reserves the right to recover, recapture or offset funds paid under this Agreement in the event City determines that Recipient will be unable to commit or expend funds within the prescribed time, as determined by City. Recipient agrees to refund to the City all funds that the City in its sole discretion determines to have been used for ineligible and/or unapproved purposes. Such refunds will be made within thirty (30) days of notification by the City of the ineligible expenditure.

Section 5.04 The Parties agree that any right or remedy provided for in this Article V or in any other provision of this Agreement is cumulative, and shall not preclude the exercise of any other right or remedy under this Agreement or under any provision of law, nor shall any action taken in the exercise of any right or remedy be deemed a waiver of any other rights or remedies. Failure to exercise any right or remedy hereunder shall not constitute a waiver of the right to exercise that or any other right or remedy at any time.

Article VI. UNIFORM ADMINISTRATIVE REQUIREMENTS, COSTS PRINCIPLES AND PROGRAM INCOME FOR GOVERNMENT ENTITIES AND NON-PROFITS

Section 6.01 Recipient shall comply with the requirements of OMB Circulars Number. A-122 "COST PRINCIPALS FOR NON PROFIT ORGANIZATIONS", OMB Circular Number A-110 "UNIFORM ADMINISTRATIVE REQUIREMENTS FOR GRANTS AND OTHER AGREEMENTS WITH INSTITUTIONS OF HIGHER EDUCATION, HOSPITALS, AND OTHER NON PROFIT ORGANIZATIONS, and 24 CFR Part 84 "UNIFORM ADMINISTRATIVE REQUIREMENTS FOR GRANTS AND AGREEMENTS WITH INSTITUTIONS OF HIGHER EDUCATION, HOSPITALS, AND OTHER NON PROFIT ORGANIZATIONS", and any other OMB Circulars which may apply either prospectively or retroactively. Recipient nonprofit organization must comply with applicable OMB Circulars pursuant to 24 CFR 92.505 and any other applicable regulations.

Article VII. RETENTION AND ACCESSIBILITY OF RECORDS

Section 7.01 Recipient must establish and maintain sufficient records, including those listed under 24 CFR 92.508. The sufficiency of the records will be determined by City.

Section 7.02 Recipient shall give HUD, the Comptroller General of the United States, the City of
Contract for Home Programs: No Limits IEDC

Bryan Auditor, or any of their duly authorized representatives, access to and the right to examine all books, accounts, records, reports, files, and other papers, things, or property belonging to or in use by Recipient pertaining to this Agreement. Such rights to access shall continue as long as the records are retained by Recipient. Recipient agrees to maintain such records in a location accessible to the above-named persons and entities.

Section 7.03 All records pertinent to this Agreement shall be retained by Recipient for five calendar years after the date of termination of this Agreement or of submission of the final close-out report, whichever is later, with the following exceptions:

- (a) If any litigation, claim or audit is started before the expiration of the five-year period and extends beyond the five-year period, the records will be maintained until all litigation, claims or audit findings involving the records have been finally resolved, including all legal and administrative appeals.
- (b) Records relating to real property acquisition shall be retained for the period of affordability required under 24 CFR Part 92.
- (c) Records covering displacement and acquisitions must be retained for at least five years after the date by which all persons displaced from the property and all persons whose property is acquired for the project have received the final payment to which they are entitled in accordance with 24 CFR 92.353.

Section 7.04 Recipient shall require the substance of this Article VII to be included in all subcontracts.

Section 7.05 Recipient must provide citizens, public agencies, and other interested parties with reasonable access to records consistent with the TEXAS PUBLIC INFORMATION ACT.

Article VIII. REPORTING REQUIREMENTS

Section 8.01 Recipient shall submit to City such reports on the operation and performance of this Agreement as may be required by City including but not limited to the reports specified in this Article VIII. Recipient shall provide City with all reports necessary for City's compliance with 24 CFR Sections 92.508, 92.509 and 24 CFR SUBPART J or any other applicable statute, law or regulation. Recipient agrees to furnish the City with information on program participants, including: income verifications, race, ethnicity, age, sex, family status, disability status and head-of-household status. Recipient will report any project and/or program delays or modifications and await City approval before proceeding. Recipient will also report any instances of client fraud or program abuse to the City. Recipient agrees to meet with the City to discuss progress or concerns as the need arises and at the City's request. Recipient also agrees to report on a bi-annual basis to the City on program/project status. This must be a written report of the status on recently completed, ongoing, and pre-approved programs and/or projects and must include information for the reporting period to include the status on: applicant approvals/denials; projects/programs approved; fund disbursements; project bidding information; property sales; contractor/subcontractor utilization to include: race, sex, ethnicity, addresses, social security numbers and amounts billed and paid; use of program income, repayments, and recaptured funds; and other information as specified by the City.

Section 8.02 In addition to the limitations on liability otherwise specified in this Agreement, it is expressly understood and agreed by the Parties hereto that if Recipient fails to submit to City in a timely and satisfactory manner any report required by this Agreement, City may, at its sole option and in its sole

discretion, withhold any or all payments otherwise due or requested by Recipient hereunder. If City withholds such payments, it shall notify Recipient in writing of its decision and the reasons therefore. Payments withheld pursuant to this paragraph may be held by City until such time as Recipient fully cures or performs any and all delinquent obligations which are identified as the reason funds are withheld.

Article IX. MONITORING

Section 9.01 The City reserves the right to carry out regular and periodic field inspections to ensure compliance with the requirements of this Agreement. Monitoring inspections may examine site work, project files, financial records, client files, intake records, or any other information as deemed applicable by the City. After each monitoring visit, City shall provide Recipient with a written report of the monitor's findings. If the monitoring reports note deficiencies in Recipient's performances under the terms of this Agreement, the monitoring report shall include requirements for the timely correction of such deficiencies by Recipient. Failure by Recipient to take action specified in the monitoring report may be cause for suspension or termination of this Agreement, as provided in Article XVIII and XIX of this Agreement.

Article X. INDEPENDENT CONTRACTOR

Section 10.01 It is expressly understood and agreed by the Parties hereto that City is contracting with Recipient as an Independent Contractor and not any employee, or agent of City. This Agreement does not establish or constitute a joint venture or enterprise between City and Recipient.

Section 10.02 By entering into this Agreement, City and Recipient do not intend to create a joint enterprise.

Article XI. INDEMNIFICATION

Section 11.01. RECIPIENT AGREES TO AND SHALL INDEMNIFY AND HOLD HARMLESS CITY, ITS PUBLIC OFFICIALS, OFFICERS, AGENTS AND EMPLOYEES FROM AND AGAINST ANY AND ALL CLAIMS, LOSSES, DEMANDS, JUDGMENTS AND CAUSES OF ACTION OF EVERY KIND AND CHARACTER INCLUDING REASONABLE ATTORNEY FEES, COSTS AND EXPERT FEES, WHICH MAY BE ASSERTED BY ANY THIRD PARTY OCCURRING OR IN ANY WAY INCIDENT TO, ARISING OUT OF, OR IN CONNECTION WITH THE SERVICES AND WORK TO BE PERFORMED BY RECIPIENT UNDER THIS AGREEMENT.

SECTION 11.02. BY ENTERING INTO THIS AGREEMENT THE CITY DOES NOT WAIVE ITS GOVERNMENTAL IMMUNITY, THE LIMITATIONS AS TO DAMAGES CONTAINED IN THE TEXAS TORT CLAIMS ACT OR CONSENT TO SUIT.

Article XII. SUBCONTRACTS

Section 12.01 Except for subcontracts to which the federal labor standards requirements apply (12 or more units), Recipient may not subcontract for performances of any obligation required or described in this Agreement without obtaining City's prior written approval. Recipient shall only subcontract for performance obligations required or described in this Agreement to which the federal labor standards requirements apply after Recipient has submitted a Subcontractor Eligibility form, as specified by City, for each such proposed subcontract and Recipient has obtained City's prior written approval, based on the information submitted, of Recipient's intent to enter into such proposed subcontract. Recipient, in

subcontracting for the performance of any obligation required as described in this Agreement, expressly understands that in entering into such subcontracts, City is in no way liable to Recipient's subcontractor(s).

Section 12.02 In no event shall any provision of this Article XII, specifically the requirement that Recipient obtain City's prior written approval of a subcontractor's eligibility, be construed as relieving Recipient of the responsibility for ensuring that the performances rendered under all subcontracts are rendered so as to comply with all of the terms of this Agreement, as if such performances rendered were rendered by Recipient. City's approval under Article XII does not constitute adoption, ratification, or acceptance of Recipient's or subcontractor's performance hereunder. City maintains the right to insist upon Recipient's full compliance with the terms of this Agreement, and by the act of approval under Article XII, City does not waive any rights or remedies which, may exist or which may subsequently accrue to City under this Agreement.

Section 12.03 Recipient shall comply with all applicable federal, state, and local laws, regulations, and ordinances for making procurement under this Agreement.

Section 12.04 Recipient shall submit a subcontractor utilization report prior to beginning work and prior to hiring any additional subcontractors.

Section 12.05 Recipient may utilize volunteer labor to accomplish the project, in which case the Recipient is responsible to ensure that the Volunteer Release and Indemnification Agreement (Exhibit G) shall be completed by each volunteer, and the original submitted to the City.

Article XIII. CONFLICT OF INTEREST

Section 13.01 No person who (a) is an employee, agent, consultant, officer or elected or appointed official of City or of any applicant that receives funds and who exercises or has exercised any functions or responsibilities with respect to activities assisted with funds provided under this Agreement or (b) who is in a position to participate in a decision-making process or gain inside information with regard to such activities may obtain a personal or financial interest or benefit from a HOME assisted activity, or have an interest in any contract, subcontract or agreement (or the proceeds thereof) with respect to a HOME assisted activity either for themselves or those with whom they have family or business ties, during their tenure or for one year thereafter. Recipient shall ensure compliance with applicable provisions under 24 CFR Sections 84.40 - 84.48 and OMB Circular A-110 in the procurement of property and services.

Article XIV. NONDISCRIMINATION AND SECTARIAN ACTIVITY

Section 14.01 Equal Opportunity. Recipient shall ensure that no person shall on the grounds of race, color, religion, sex, handicap, family status, or national origin be excluded from participation in, be denied the benefits of, or be subjected to discrimination under any program or activity funded in whole or in part with funds provided under this Agreement. In addition, funds provided under this Agreement must be made available in accordance with the requirements of Section 3 of the HOUSING AND URBAN DEVELOPMENT ACT OF 1968 (12USC1701u) that:

- (a) To the greatest extent feasible, opportunities for training and employment arising in connection with the planning and carrying out of any project assisted with HOME funds provided under this Agreement be given to low-income persons residing within the general local government area in which the project is located; and

- (b) To the greatest extent feasible, contracts for work to be performed in connection with any such project be awarded to business concerns, including, but not limited to, individuals or firms doing business in the field of planning, consulting, design, architecture, building construction, rehabilitation, maintenance, or repair, which are located in or owned in substantial part by persons residing in the same metropolitan area or non-metropolitan City as the project.

Section 14.02 Religious Organizations. Funds provided under this Agreement may not be provided to primarily religious organizations, such as churches, for any activity, including secular activities. In addition, funds provided under this Agreement may not be used to rehabilitate or construct housing owned by primarily religious organizations, such as churches, for any activity, including secular activities. In addition, funds provided under this Agreement may not be used to rehabilitate or construct housing owned by primarily religious organizations or to assist primarily religious organizations in acquiring housing. The completed housing project must be used exclusively by the owner entity for secular purposes and must be available to all persons regardless of religion. There must be no religious or membership criteria for tenants of the property as specified under 24 CFR 92.257.

Article XV. LEGAL AUTHORITY

Section 15.01 Recipient assures and guarantees that Recipient possesses the legal authority to enter into this Agreement, to receive funds authorized by this Agreement, and to perform the services Recipient has obligated itself to perform hereunder.

Section 15.02 The person or persons signing and executing this Agreement on behalf of Recipient, or representing themselves as signing and executing this Agreement on behalf of Recipient, do hereby warrant and guarantee that he, she or they have been duly authorized by Recipient to execute this Agreement on behalf of Recipient and to validly and legally bind Recipient to all terms, performances, and provisions herein set forth.

Section 15.03 Recipient shall not employ, award contract to, or fund any person that has been debarred, suspended, proposed for debarment, or placed on ineligibility status by U.S. Department of Housing and Urban Development. In addition, City shall have the right to suspend or terminate this Agreement if Recipient is debarred, suspended, proposed for debarment, or ineligible to participate in the HOME Program.

Article XVI. LITIGATION AND CLAIMS

Section 16.01 Recipient shall give City immediate notice in writing of a) any action, including any proceeding before an administrative agency, brought or filed against Recipient in connection with this Agreement; and b) any claim against Recipient, the cost and expense of which Recipient may be entitled to be reimbursed by City.

Except as otherwise directed by City, Recipient shall furnish immediately to City copies of all documents received by Recipient with respect to such action, proceeding, or claim.

Article XVII. CHANGES AND AMENDMENTS

Section 17.01 Except as specifically provided otherwise in this Agreement, any alterations, additions, or deletions to the terms of this Agreement shall be by amendment hereto in writing and executed by both the Parties to this Agreement.

Section 17.02 It is understood and agreed by the Parties hereto that any performance under this Agreement must be rendered in accordance with the Act, the regulations promulgated under the Act, the assurances and certifications made to City by Recipient, and the assurances and certifications made to the United States Department of Housing and Urban Development by the City with regard to the operation of the HOME Program.

Section 17.03 Any alterations, additions, or deletions to the terms of this Agreement which are required by changes in Federal or state law or regulations are automatically incorporated into this Agreement without written amendment hereto, and shall become effective on the date designated by such law or regulations. All other amendments to the Agreement must be in writing and signed by both Parties, except as provided in paragraphs 17.02 and 17.03.

Article XVIII. SUSPENSION

Section 18.01 In the event Recipient fails to comply with any term of this Agreement, City may, upon written notification to Recipient, suspend this Agreement in whole or in part and withhold further payments to Recipient, and prohibit Recipient from incurring additional obligations of funds under this Agreement.

Article XIX. TERMINATION

Section 19.01 The City may terminate this Agreement in whole or in part, in accordance with 24 CFR 85.43 and this Article or as provided in this Agreement. In the event Recipient materially fails as determined by City, to comply with any term of this Agreement, whether stated in a Federal statute or regulation, an assurance, in a City plan or application, a notice of award, or elsewhere, City may take one or more of the following actions:

- (a) Temporarily withhold cash payments pending correction of the deficiency or default by the Recipient.
- (b) Disallow all or part of the cost of the activity or action not in compliance; and require immediate repayment of such disallowed costs.
- (c) Withhold further HOME awards from Recipient.
- (d) Exercise other rights and remedies that may be legally available as determined by the City to comply with the terms of this Agreement.
- (e) City may terminate this Agreement for convenience in accordance with 24 CFR 85.44.

Article XX. AUDIT

Section 20.01 Unless otherwise directed by City, Recipient shall arrange for the performance of an annual financial and compliance audit of funds received and performances rendered under this Agreement, subject to the following conditions and limitations:

- (a) Recipient shall have an audit made in accordance with 24 CFR 92.506, THE SINGLE AUDIT ACT OF 1984, 31 U.S.C. 7501 et. seq., and OMB Circular No.133, "AUDITS OF STATES, LOCAL Contract for Home Programs: No Limits IEDC

GOVERNMENTS, AND NON-PROFIT ORGANIZATIONS", for any of its fiscal years included within the Agreement Period, in which Recipient receives more than \$300,000.00 in federal financial assistance provided by a federal agency in the form of grants, contracts, loans, loan guarantees, property, cooperative agreements, interest subsidies, insurance or direct appropriations, but does not include direct federal cash assistance to individuals. The term includes awards of federal financial assistance received directly from federal agencies, or indirectly through other units of State and local government;

- (b) At the option of Recipient, each audit required by this Article may cover either Recipient's entire operations or each department, agency, or establishment of Recipient which received, expended, or otherwise administered federal funds;
- (c) Unless otherwise specifically authorized by City in writing, Recipient shall submit the complete and final report of such audit to City within thirty (30) days after completion of the audit, but no later than one (1) year after the end of each fiscal period included within the period of this Agreement. Audits performed under Subsection A of this Article XX are subject to review and resolution by City or its authorized representative.
- (d) As part of its audit, Recipient shall verify expenditures according to the Budget attached as Exhibit B.

Section 20.02 Notwithstanding Paragraph 20.01 City reserves the right to conduct an annual financial and compliance audit of funds received and performances rendered under this Agreement. Recipient agrees to permit City or its authorized representative to audit Recipient's records and to obtain any documents, materials, or information necessary to facilitate such audit.

Section 20.03 Recipient understands and agrees that it shall be liable to City for any costs disallowed pursuant to financial and compliance audit(s) of funds received under this Agreement. Recipient further understands and agrees that reimbursement to City of such disallowed costs shall be paid by Recipient from funds which were not provided or otherwise made available to Recipient under this Agreement.

Section 20.04 Recipient shall take all necessary actions to facilitate the performance of such audit or audits conducted pursuant to this Article XX as City may require of Recipient.

Section 20.05 All approved HOME audit reports shall be made available for public inspection within 30 days after completion of the audit.

Article XXI. ENVIRONMENTAL CLEARANCE REQUIREMENTS

Section 21.01 Recipient understands and agrees that by the execution of this Agreement, City shall assume the responsibilities for environmental review, decision making, and other action which would otherwise apply to City in accordance with and to the extent specified in 24 CFR, PART 58. In accordance with 24 CFR 58.77(b), Recipient further understands and agrees that City shall handle inquiries and complaints from persons and agencies seeking redress in relation to environmental reviews covered by approved certifications.

Section 21.02 Funds provided under this Agreement may not be obligated and expended before the actions specified in this Article occur.

Section 21.03 City shall prepare and maintain a written Environmental Review Record for this project
Contract for Home Programs: No Limits IEDC

in accordance with 24 CFR PART 58 to ensure compliance with the NATIONAL ENVIRONMENTAL POLICY ACT (NEPA). Recipient must also maintain a copy of the Environmental Review Record in Recipient's project file. City must comply with all other applicable environmental requirements as specified in Exhibit D of this Agreement. City shall document its compliance with such other requirements in its environmental review file.

Article XXII. SPECIAL CONDITIONS

Section 22.01 City shall not release any funds for any costs incurred by Recipient under this Agreement until City has received certification from Recipient that its fiscal control and fund accounting procedures are adequate to assure the proper disbursement of and accounting for funds provided under this Agreement. City shall specify the content and form of such certification.

Section 22.02 Affordability. Funds provided under this Agreement must meet the affordability requirement of 24 CFR Part 92 and the HOME rules as applicable. The City shall reduce HOME investment amount to be recaptured on a pro-rata basis for the time the unit is in compliance with 24 CFR 92 and the HOME rules as applicable.

Section 22.03 Repayment. Recipient agrees that all repayments, including all interest and any other return on the investment of HOME funds will be made to City pro-rata. The formula for repayment is the funds received which are subject to repayment divided by the number of months in the period of affordability multiplied by the number of months that a home is not operated in accordance with the affordability requirement.

Section 22.04 Housing Quality Standards. Recipient shall ensure that all housing assisted with funds provided under this Agreement shall meet the requirements of 24 CFR 92.251 for the duration of this Agreement.

Section 22.05 Affirmative Marketing. Should funds from this Agreement be used in the construction of five (5) or more dwelling units, Recipient shall adopt Affirmative Marketing procedures and requirements. The Affirmative Marketing procedures and requirements shall include, but need not be limited to, those specified in 24 CFR 92.351. City will assess the efforts of the Recipient during the marketing of the units by use of compliance certification. Where a Recipient fails to follow the Affirmative Marketing procedures and requirements, corrective actions shall include extensive outreach efforts to appropriate contacts to achieve the occupancy goals or other sanctions the City may deem necessary. Recipient must provide City with an annual assessment of the Affirmative Marketing program of the development, if and Affirmative Marketing program is required under this section. The assessment must include:

- (a) Method used to inform the public and potential residents about Federal Fair Housing laws and Affirmative Marketing policy. Recipient's advertising of housing must include the Equal Housing Opportunity logo or statement. Advertising media may include newspaper, radio, television, brochures, leaflets, or signage. Recipient may wish to use community organizations, places of worship, employment centers, fair housing groups, housing counseling agencies, social service centers or medical service centers as resources for this outreach.
- (b) Records describing actions taken by the Recipient to affirmatively market housing and records to assess the results of these actions. Recipient must maintain a file containing all marketing efforts (i.e. copies of newspaper ads, memos of phone calls, copies of letters) to be available for inspection at least annually by City.

- (c) Recipient shall solicit applications for housing from persons in the housing market who are least likely to apply for housing without benefit of special outreach efforts. In general, persons who are not of the race/ethnicity of the residents of the neighborhood in which the housing is located shall be considered those least likely to apply.
- (d) Recipient shall maintain a listing of all residents residing in each home through the end of the compliance period.
- (e) The Recipient will take all necessary affirmative steps to assure that minority firms, women's business enterprises, and labor surplus area firms are used when possible. Affirmative steps shall include: Placing qualified small and minority businesses and women's business enterprises on solicitation lists; Assuring that small and minority businesses, and women's business enterprises are solicited whenever they are potential sources; Dividing total requirements, when economically feasible, into smaller tasks or quantities to permit maximum participation by small and minority business, and women's business enterprises; Establishing delivery schedules, where the requirement permits, which encourage participation by small and minority business, and women's business enterprises; Using the services and assistance of the Small Business Administration, and the Minority Business Development Agency of the Department of Commerce; and requiring the prime contractor, if subcontracts are to be let, to take the affirmative steps listed in the preceding paragraph.

Section 22.06 Enforcement of Affordability. For each activity assisted under this Agreement, agreements preserving the required affordability period shall be recorded in the real property records of Brazos County.

- (a) Homebuyer Activities: For homebuyer activities, City shall provide a legally enforceable agreement consisting of a Real Estate Lien Note and Deed of Trust, containing remedies adequate to enforce the affordability requirements of 24 CFR 92.254. The note and deed of trust will have a term of fifteen (15) years. Funds recaptured because housing no longer meets the affordability requirements under 24 CFR 92.254(a)(5) are subject to the requirements of 24 CFR 92.503.
- (b) Rental Activities: For rental activities, City shall provide a legally enforceable Land Use Restriction Agreement (LURA) containing remedies adequate to enforce the affordability requirements of 24 CFR 92.252. The LURA will have a term of twenty (20) years. Funds recaptured because housing no longer meets the affordability requirements under 24 CFR 92.252(e) are subject to the requirements of 24 CFR 92.503.

Section 22.07 Reversion of Assets. Upon termination of this Agreement, all funds remaining on hand on the date of termination and all accounts receivable attributable to the use of funds received under this agreement shall revert to City. Recipient shall return these assets to City within seven (7) days after the date of termination. This section does not refer to CHDO proceeds from the sale of property.

Section 22.08 Flood Hazards. Funds provided under this Agreement may not be used in connection with acquisition, rehabilitation, or construction of a development located in an area identified by the Federal Emergency Management Agency (FEMA) as having special flood hazards.

Section 22.09 Fair Housing. Recipient participating in the HOME program shall use affirmative fair housing marketing practices in determining eligibility and concluding all transactions. These
Contract for Home Programs: No Limits IEDC

requirements apply to all projects of five (5) or more units. Each participating entity must affirmatively further fair housing in accordance with 24 CFR 92.350.

Section 22.10 Displacement, Relocation, and Acquisition. Recipient must ensure that it has taken all reasonable steps to minimize the displacement of persons (families, business and nonprofit organizations) as a result of a project assisted with funds provided under this Agreement. Recipient must comply with the applicable provisions of 24 CFR 92.353.

Section 22.11 Property Standards. Recipient shall ensure that all housing assisted with funds provided under this Agreement (1) shall meet the lead-based paint requirements in 24 CFR 92.355 upon project completion and (2) shall meet the requirements of 24 CFR 92.355 for the duration of this Agreement.

Section 22.12 All documents necessary for the conveyance of real property, pursuant to the Agreement, must be approved, prior to execution, by the City. (i.e. deeds, notes, Deed of Trust, leases, etc.)

Section 22.13 Funding under this Agreement is contingent upon Recipient meeting all terms, conditions of this Agreement.

Section 22.14 This Agreement and the performance hereunder may not be assigned without the express written consent of City.

Section 22.15 This Agreement is binding on Recipient's assigns and successors-in-interest.

Article XXIII. ORAL AND WRITTEN CONTRACTS

Section 23.01 All oral and written contracts between the Parties relating to the subject matter of this Agreement that were made prior to the execution of this Agreement have been reduced to writing and are contained in this Agreement.

Section 23.02 The attachments enumerated and denominated below are hereby made a part of this Agreement, and constitute promised performances by Recipient in accordance with Article III of this Agreement.

- (a) Exhibit A. Performance Statement
- (b) Exhibit B. Budget
- (c) Exhibit C. Project Implementation Schedule
- (d) Exhibit D. Applicable Laws and Regulations
- (e) Exhibit E. Certifications
- (f) Exhibit F. Community Development Services Residential Construction Standards
- (g) Exhibit G. Volunteer Release and Indemnification Agreement

Article XXIV. VENUE

Section 24.01 For purposes of litigation pursuant to this Agreement, venue shall lie in Brazos County, Texas.

Article XXV. COMPLIANCE WITH FEDERAL, STATE AND LOCAL LAWS

Section 25.01 Recipient shall comply with all federal, state and local laws, statutes, ordinances, rules, regulations, orders and decrees of any court or administrative body or tribunal related to the activities and performances of contractor under this Agreement. Upon request by City, Recipient shall furnish satisfactory proof of its compliance herein.

EXECUTED AND EFFECTIVE on this 5th day of September, 2012.

CITY OF BRYAN

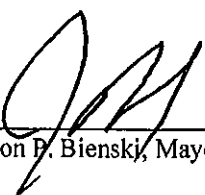

Jason P. Bienski, Mayor

**NO LIMITS INTERNATIONAL
ECONOMIC DEVELOPMENT,
INC.**



Warren Roberts, Board President

ATTEST:



Mary Lynne Stratta, City Secretary

APPROVED AS TO FORM:

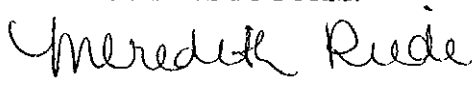

for Janis Hampton, City Attorney

**EXHIBIT A
PERFORMANCE STATEMENT**

NO LIMITS INTERNATIONAL ECONOMIC DEVELOPMENT, INC.

- (1) Award. Recipient is awarded \$70,782.00 from the City of Bryan FY 2012 Budget (\$62,662 FROM HUD GRANT YEAR 2011 AND \$8,120 FROM HUD GRANT YEAR 2010) Community Development Services Department HOME Investment Partnerships Program funds. These funds must be used for: Acquisition and construction of Affordable Housing on the undeveloped property described as Lot 2, Block 199, City of Bryan Townsite, Bryan, Brazos County, Texas, also known as 606 W. 21st St. The home(s) constructed shall be of a design approved by the City.
- (2) Design and Construction.
 - a. Exterior construction shall consist of a minimum of 25% brick or stone veneer, with any remainder being fiber-cement siding. The brick portion will either be on the entire front of the home, or may be applied in wainscot fashion around the complete exterior, with the brick or stone veneer extending from the slab up to a reasonable and aesthetically appropriate height. Recipient shall submit final plans and specifications to the City's Community Development Services Department.
 - b. In addition to meeting minimum code requirements, the following features shall be installed:
 - i. AS SPECIFIED IN RESPONSE TO RFP #12-032
 - ii. Storage structure, garage, or exterior-access storage room with a minimum unobstructed open area of 80 square feet.
 - c. Preconstruction Conference Required: At least ten (10) days prior to applying for a building permit, Recipient shall attend a preconstruction conference with the City of Bryan Community Development Services Department to discuss the following issues:
 - i. Plans and Specifications Preview
 - ii. Press Release and Signage
 - iii. Draw Procedures
- (3) Substantially as in Response to RFP. Uses of funds, design, and construction, and all other elements of the project shall be to accomplish the development and sale or lease of property to income-eligible households, substantially as submitted by the CHDO in the Proposal submitted in response to the City of Bryan Request for Competitive Sealed Proposals RFP #12-032.
- (4) Codes. All work must be in compliance with current City of Bryan Building Codes. All required permits must be obtained prior to any work commencing. All required inspections must be performed by the City of Bryan Building Inspectors.
- (5) Easements. Recipient shall dedicate any easements required by City including blanket easements which shall be substituted with as-built easements for all City utilities.
- (6) Recipient must provide written notification of all subcontractors to City on the Subcontractor Utilization Report form with all required subcontractor information, and required information on program participants.

- (7) Completion. The project must be substantially completed within one (1) year of the date of this contract. Upon completion of such construction Recipient must submit a copy of all receipts paid for the work associated with this contract. At that point, the City will have 30 days to make payment on said receipts, not to exceed maximums established in Exhibit B, Budgets.
- (8) Occupancy. Within six (6) months from issuance of the Certificate of Occupancy, said HOME unit must be occupied by an eligible resident. Recipient is not prohibited from conducting background check on credit history or criminal history.
- (9) Recapture, Repayment, Program Income, and Project Proceeds. Income does not constitute program income, recaptured funds, or repayment of funds. However, any program income, recaptured funds, recaptured funds, or repayment of any funds must be immediately returned to the City of Bryan Community Development Services Department - HOME Investment Partnerships Program. The City grants the Recipient the authority for the right to maintain all project proceeds. Any/All program income, recaptured funds, repaid funds, project proceeds, etc., are subject to this contract.

**EXHIBIT B
BUDGET**

NO LIMITS INTERNATIONAL ECONOMIC DEVELOPMENT, INC.

SOURCES OF FUNDS:

Maximum Proceeds of Grant Under the Contract	\$70,782.00
--	-------------

USES OF FUNDS:

Eligible Acquisition and Construction Costs	\$ 63,703.80
Maximum Program Delivery Expense (10% of Proceeds)	\$ 7,078.20

EXHIBIT C

PROJECT IMPLEMENTATION SCHEDULE

CONTRACT START DATE: August 28, 2012

CONTRACT END DATE: August 27, 2014

Acquisition Phase – Acquisition of the property shall be completed by September 28, 2012.

Pre-Construction Phase – Pre-construction survey, title, and design activities shall be completed by December 31, 2012.

Construction Phase – Construction for this project is scheduled to begin no later than January 1, 2013, with completion, certificate of occupancy, and final reimbursement draw request date no later than August 27, 2014. The issuance of a building permit will constitute start of construction.

Marketing and Occupancy – Marketing of the completed project will begin no later than the date of issuance of the Certificate of Occupancy. Placement of a print advertisement in Bryan-College Station Eagle newspaper or a listing in the Bryan College Station Regional Association of Realtors Multiple Listing Service shall constitute the initiation of marketing. Occupancy of the completed project by a qualified homebuyer or renter household shall be within six months of the issuance of the Certificate of Occupancy.

EXHIBIT D

THE APPLICABLE LAWS AND REGULATIONS

Recipient shall comply with all federal, state, and local laws and regulations applicable to the activities and performances rendered by Recipient under this contract including but not limited to the laws, and the regulations specified in Section I through VI of this Exhibit D.

I. CIVIL RIGHTS

THE FAIR HOUSING ACT (42 U.S.C. 3601-20) AND IMPLEMENTING REGULATIONS AT 24 CFR PART 100; EXECUTIVE ORDER 11063, AS AMENDED BY EXECUTIVE ORDER 12259 (3 CFR, 1958-1963 COMP., P. 652 AND 3 CFR, 1980 COMP., P. 307) (EQUAL OPPORTUNITY IN HOUSING) AND IMPLEMENTING REGULATIONS AT 24 CFR, PART 107; AND TITLE VI OF THE CIVIL RIGHTS ACT OF 1964 (42 U.S.C. 2000D) (NONDISCRIMINATION IN FEDERALLY ASSISTED PROGRAMS) AND IMPLEMENTING REGULATIONS ISSUED AT 24 CFR, PART 1;

EXECUTIVE ORDER 11063, AS AMENDED BY EXECUTIVE ORDER 12259, AND 24 CFR PART 107, "NONDISCRIMINATION AND EQUAL OPPORTUNITY IN HOUSING UNDER EXECUTIVE ORDER 11063". THE FAILURE OR REFUSAL OF RECIPIENT TO COMPLY WITH THE REQUIREMENTS OF EXECUTIVE ORDER 11063 OR 24 CFR, PART 107 SHALL BE A PROPER BASIS FOR THE IMPOSITION OF SANCTIONS SPECIFIED IN 24 CFR 107.60;

THE PROHIBITION AGAINST DISCRIMINATION ON THE BASIS OF AGE UNDER THE AGE DISCRIMINATION ACT OF 1975 (42 U.S.C. 6101-07) AND IMPLEMENTING REGULATIONS AT 24 CFR, PART 146, AND THE PROHIBITIONS AGAINST DISCRIMINATION AGAINST HANDICAPPED INDIVIDUALS UNDER SECTION 504 OF THE REHABILITATION ACT OF 1973 (29 U.S.C. 794) AND IMPLEMENTING REGULATIONS AT 24 CFR, PART 8;

THE PROHIBITION AGAINST DISCRIMINATION ON THE BASIS OF SEXUAL ORIENTATION OR GENDER IDENTITY BY HUD POLICY RULE AS PUBLISHED IN FR-5359.

THE REQUIREMENTS OF EXECUTIVE ORDER 11246 (3 CFR 1964-65, COMP., P. 339) (EQUAL EMPLOYMENT OPPORTUNITY) AND THE IMPLEMENTING REGULATIONS ISSUED AT 41 CFR, CHAPTER 60.

THE REQUIREMENTS OF 24 CFR 92.351 (MINORITY OUTREACH), EXECUTIVE ORDERS 11625 AND 12432 (CONCERNING MINORITY BUSINESS ENTERPRISE), AND 12138 (CONCERNING WOMEN'S BUSINESS ENTERPRISE). CONSISTENT WITH HUD'S RESPONSIBILITIES UNDER THESE ORDERS, RECIPIENT MUST MAKE EFFORTS TO ENCOURAGE THE USE OF MINORITY AND WOMEN'S BUSINESS ENTERPRISES IN CONNECTION WITH HOME FUNDED ACTIVITIES. RECIPIENT MUST PRESCRIBE PROCEDURES ACCEPTABLE TO THE CITY TO ESTABLISH ACTIVITIES TO ENSURE THE INCLUSION, TO THE MAXIMUM EXTENT POSSIBLE, OF MINORITIES AND WOMEN, AND ENTITIES OWNED BY MINORITIES AND WOMEN. THE CONTRACTOR / SUBCONTRACTOR WILL BE REQUIRED TO IDENTIFY CONTRACTS WHICH HAVE BEEN BID BY MINORITY OWNED, WOMEN OWNED, AND/OR SMALL DISADVANTAGED BUSINESSES.

THE AGE DISCRIMINATION ACT OF 1975 (42 U.S.C., SECTION 6101 ET SEQ.);

SECTION 504 OF THE REHABILITATION ACT OF 1973 (29 U.S.C., SECTION 794) AND "NONDISCRIMINATION BASED ON HANDICAP IN FEDERALLY-ASSISTED PROGRAMS AND

ACTIVITIES OF THE DEPARTMENT OF HOUSING AND URBAN DEVELOPMENT", 24 CFR, PART 8. BY SIGNING THIS CONTRACT, RECIPIENT UNDERSTANDS AND AGREES THAT THE ACTIVITIES FUNDED HEREIN SHALL BE OPERATED IN ACCORDANCE WITH 24 CFR, PART 8; AND THE ARCHITECTURAL BARRIERS ACT OF 1968 (42 U.S.C., SECTION 4151 ET. SEQ.) INCLUDING THE USE OF A TELECOMMUNICATIONS DEVICE FOR DEAF PERSONS (TDDs) OR EQUALLY EFFECTIVE COMMUNICATION SYSTEM.

SECTION 3 OF THE HOUSING AND URBAN DEVELOPMENT ACT OF 1968(24 CFR PART 135.38) CHDO'S ARE ENCOURAGED, TO THE GREATEST EXTENT FEASIBLE, TO PROVIDE OPPORTUNITIES FOR TRAINING AND EMPLOYMENT FOR LOWER INCOME RESIDENTS AND BUSINESSES OF THE PROJECT AREA.

PATENT AND COPYRIGHT INFRINGEMENT NOTICE: SERVICE PROVIDER SHALL COMPLY WITH REGULATIONS PERTAINING TO COPYRIGHTS AND RIGHTS IN DATA AND REQUIREMENTS PERTAINING TO PATENT RIGHTS WITH RESPECT TO ANY DISCOVERY OR INVENTION WHICH ARISES OR IS DEVELOPED IN THE COURSE OF OR UNDER SUCH CONTRACT.

II. LEAD-BASED PAINT

TITLE IV OF THE LEAD-BASED PAINT POISONING PREVENTION ACT (42 U.S.C. SEC. 4831).

III. ENVIRONMENTAL STANDARDS

NATIONAL ENVIRONMENTAL POLICY ACT OF 1969 (42 U.S.C. SEC. 4321 ET. SEQ.) AND 40 CFR PARTS 1500-1508;

THE NATIONAL HISTORIC PRESERVATION ACT OF 1966 (16 U.S.C. SEC. 470 ET. SEQ.) AS AMENDED; PARTICULARLY SECTION 106 (16 U.S.C. SEC. 470F);

EXECUTIVE ORDER 11593, PROTECTION AND ENHANCEMENT OF THE CULTURAL ENVIRONMENT, MAY 13, 1971 (36 FED. REG. 8921), PARTICULARLY SECTION 2(C);

THE RESERVOIR SALVAGE ACT OF 1960 (16 U.S.C. SEC. 469 ET SEQ.). PARTICULARLY SECTION 3 (16 U.S.C. SEC. 469A-1), AS AMENDED BY THE ARCHEOLOGICAL AND HISTORIC PRESERVATION ACT OF 1974; FLOOD DISASTER PROTECTION ACT OF 1973, (42 U.S.C. SEC. 4001 ET. SEQ.) AS AMENDED, PARTICULARLY SECTIONS 102(A) AND 202(A) (42 U.S.C. SEC. 4012A (A) AND SEC. 4106(A);

EXECUTIVE ORDER 11988, FLOODPLAIN MANAGEMENT, MAY 24, 1977 (42 FED. REG. 26951), PARTICULARLY SECTION 2(A).

EXECUTIVE ORDER 11990 PROTECTION OF WETLANDS, MAY 24, 1977 (42 FED. REG. 26961), PARTICULARLY SECTIONS 2 AND 5.

THE SAFE DRINKING WATER ACT OF 1974, (42 U.S.C. SEC. 201, 300(F) ET SEQ.) AND (21 U.S.C. SEC. 349) AS AMENDED, PARTICULARLY SECTION 1424(E) (42 U.S.C. SEC. 300H-303(E);

THE ENDANGERED SPECIES ACT OF 1973, (16 U.S.C. SEC. 1531 ET. SQ.) AS AMENDED, PARTICULARLY SECTION 7 (16 U.S.C. SEC. 1536);

THE WILD AND SCENIC RIVERS ACT OF 1968, (16 U.S.C. SEC. 1271 ET SEQ.) AS AMENDED, PARTICULARLY SECTION 7(B) AND (C) (16 U.S.C. SEC. 1278 (B) AND (C));

THE CLEAN AIR ACT (41 U.S.C. SEC. 7401 ET SEQ.) AS AMENDED, PARTICULARLY SECTION 176(C) AND (D) (42 U.S.C. SEC. 7506 (C) AND (D));

FARMLANDS PROTECTION AND POLICY ACT OF 1981, (7 U.S.C. SEC. 4201 ET SEQ.)

24 CFR PART 51, ENVIRONMENTAL CRITERIA AND STANDARDS.

IV. ACQUISITION/RELOCATION

THE UNIFORM RELOCATION ASSISTANCE AND REAL PROPERTY ACQUISITION POLICIES ACT OF 1970 (42 U.S.C., SEC. 4601 ET. SEQ.), 49 CFR PART 24, AND 24 CFR SECTION 570.496A (55 FED. REG. 29309 (JULY 18, 1990)

ANTI-DRUG ABUSE ACT OF 1988 (42 U.S.C. 11901 ET. SEQ.) REGARDING TERMINATION OF TENANCIES FOR DRUG RELATED OFFENSES IN ASSISTED HOUSING.

V. LABOR REQUIREMENTS

CONTRACT WORK HOURS AND SAFETY STANDARDS ACT, AS AMENDED (40 USC 327-333), COPELAND (ANTI-KICKBACK) ACT (40 USC 276C), FAIR LABOR STANDARDS ACT OF 1938, AS AMENDED (29 USC 201, ET. SEQ.), AND DAVIS-BACON AND RELATED ACTS (40 USC 276(A)-7) (12 OR MORE UNITS ONLY).

EMPLOYMENT OF CERTAIN PERSONS PROHIBITED: NO PERSON UNDER THE AGE OF SIXTEEN YEARS AND NO PERSON WHO, AT THE TIME, IS SERVING SENTENCE IN A PENAL OR CORRECTIONAL INSTITUTION SHALL BE EMPLOYED IN THE WORK OF THIS PROJECT.

H.B. 275, THE TEXAS PROMPT PAYMENT ACT: SERVICE PROVIDER SHALL COMPLY WITH THE TEXAS PROMPT PAYMENT ACT, EFFECTIVE JULY 1, 1986, WHICH IN PART, REQUIRES THE SERVICE PROVIDER TO PAY THEIR SUBCONTRACTORS WITHIN TEN (10) CALENDARS DAYS AFTER THEY RECEIVE PAYMENT FROM THE CITY OF BRYAN.

EXHIBIT E

**CERTIFICATION REGARDING LOBBYING FOR
CONTRACTS, GRANTS, LOANS, AND COOPERATIVE AGREEMENTS**

The undersigned certified, to the best of its knowledge and belief, that:

1. No federal appropriated funds have been paid or will be paid, by or on behalf of the undersigned, to any person for influencing or attempting to influence an officer or employee of an agency, a member of congress, an officer or employee of congress, or an employee of a member of congress in connection with the awarding of any federal contract, the making of any federal loan, the entering into of any cooperative agreement or modification of any federal contract, grant, loan, or cooperative agreement.
2. If any funds other than federal appropriated funds have been paid or will be paid to any person for influencing or attempting to influence an officer or employee of any agency, a member of congress, an officer or employee of congress, or an employee of a member of congress in connection with this federal contract, grant, loan, or cooperative agreement, the undersigned shall complete and submit standard form LLL, "Disclosure Form to Report Lobbying", in accordance with its instructions.

The undersigned shall require that the language of this certification be included in the award documents for all sub-awards at all tiers (including subcontracts, sub-grants, and contracts under grants, loans, and cooperative agreements) and that all sub recipients shall certify and disclose accordingly.

This certification is material representation of fact which reliance was placed when this transaction was made or entered into. Submission of this certification is a prerequisite for making or entering into this transaction imposed by section 1352, Title 31, U.S. Code. Any person who fails to file the required certification shall be subject to a civil penalty of not less than \$10,000 and not more than \$100,000 for each such failure.

Signed: BY:

Warren Roberts

Warren Roberts, Board President
No Limits International Economic Development, Inc.

DATE: _____

Exhibit F

CITY OF BRYAN
COMMUNITY DEVELOPMENT SERVICES
RESIDENTIAL CONSTRUCTION STANDARDS

I. **GENERAL**

- a. All standards listed herein that are in conflict with applicable City ordinances and/or building codes, shall be rejected and the applicable development standards shall prevail if more restrictive. All standards listed herein that are in conflict with applicable property deed restrictions, shall be rejected and the applicable property deed restrictions shall prevail if more restrictive.
- b. These Residential Building Development Standards are the City of Bryan's basic minimum standards by which a residential structure may be approved for development.
- c. Any conflict between these standards and the City's codes and ordinances shall be brought to the attention of the Community Development Services Department.

II. **SITE**

- a. Building foundation finished grade shall be formed to a minimum of 6" higher than the highest point of existing topographical gradient within the building footprint. In the cases where a building is constructed partially or completely in a flood plain, applicable national building standards for building in a flood plain shall prevail.
- b. Finished grade around the building perimeter shall be a minimum of 4" below brick ledge or bottom of siding, and all site grading shall be manipulated and sloped to move water away from building foundation, and towards a natural flow drainage area. Site drainage grading shall meet the approval of the City's Drainage Engineer.
- c. All yard area shall be sodded or hydro-seeded with Bermuda grass (native to Brazos Valley area climate) and kept alive and maintained until the house is conveyed to a qualified buyer.
- d. A minimum of one - 2" diameter tree (native to Brazos Valley area climate) shall be placed in the front yard and kept alive and maintained until the house is conveyed to a qualified buyer.
- e. Sanitary sewer, water, gas and rainwater drainage utility service lines shall be buried at minimum bury depths in accordance with applicable City codes and ordinances. Aerial phone, cable and electrical utility service lines shall be installed at heights that comply with City codes and ordinances and shall not interfere with typical equipment common to residential neighborhoods.

- f. Site plantings of trees, bushes and shrubs shall be installed in accordance with applicable City codes and ordinances, and shall not obstruct traffic vision of neighborhood driveways and pedestrians.
- g. If property landscape development is regulated by deed restrictions, deed restrictions shall prevail.

III. FOUNDATION

- a. Foundations shall be constructed in compliance with the most currently adopted City residential building codes and ordinances. However, it is a good practice for an engineer to design foundation plans and details based upon the soil beneath the foundation, and the loads that will be imposed upon the foundation.
- b. Foundation footprints shall be established within the property building set-back lines, unless a variance has been requested and granted by the appropriate City board or commission prior to construction. City staff may not always support a contractor/developer variance request, but reasons regarding staff opposition to the variance shall be explained to the contractor/developer prior to the variance hearing.
- c. Recessed brick ledges shall be installed at all exterior masonry veneer locations. No recessed brick ledge shall be installed in areas where siding is used at the base of the exterior wall.
- d. No block and pad pier and beam-type foundations shall be allowed on new construction homes. Architect and/or engineer-approved drilled pier foundations may be used.

IV. EXTERIOR BUILDING ENVELOPE

- a. Builders are encouraged to incorporate the City of Bryan and Bryan Texas Utilities Green Plus energy rebate program into their home design.
- b. Exterior wall area shall be composed of a minimum of 25% brick, stone or stucco veneer. Remaining exterior wall area shall be composed of Hardie® brand lap siding or an equivalent product in material composition to the Hardie® brand.
- c. Exterior walls shall be rated at R-13 minimum and the attic space shall be rated at R-30 as per City codes.
- d. Windows shall be double insulated, low-E designed windows that comply and are installed in accordance with the currently adopted International Energy Conservation Code, and shall be sized in accordance with the International Residential Code for emergency egress.
- e. Exterior doors shall be six-panel, metal insulated, foam core doors. Front and rear doors may have a half-moon window or other door top window which is out of reach of the door locks for security purposes. A peep-hole shall be installed in front door if a solid front door is selected. All exterior doors shall be weather-stripped, pre-hung units with one of the doors (preferably front) required to be a 3068 door.

- f. Exterior wall sheathing shall be 7/16" OSB or 1/2" plywood, covered with IECC recommended house wrap, spliced, taped and appropriately folded and sealed into exterior wall openings, and all wall penetrations properly sealed.
- g. All pipe penetrations through the exterior walls shall be sleeved with steel pipe or galvanized sleeves the thickness of the penetrated areas, and penetrate as close to the equipment as possible, or as low as possible for proper discharge. No pipes or HVAC line-sets shall run down the brick face to equipment, or covered with a shroud. All gaps between sleeves and pipes shall be filled with latex caulk to match as close as possible the color of the brick grout. Expanding foam may also be used, but foam or caulk shall have smooth finish with sleeve opening NO BEADS OR PROTRUSIONS.
- h. All exterior wall bottom plates shall be wolmanized treated 2" x 4" nominal sized #2 southern yellow pine lumber material. All exterior wall studs shall be #2 kiln-dried southern yellow pine lumber material. Top plates shall be 2" x 4" nominal sized southern yellow pine lumber material. Multi-story homes shall use nominally sized southern pine lumber material and/or engineered laminated products sized to the support load.
- i. Soffits shall be constructed of HardieSoffit® brand perforated soffit, and all exterior brick frieze and trim materials shall be HardieTrim® brand materials (or approved equals).
- j. Roof sheathing shall be 15/32" Georgia Pacific Plytanium® Thermostat® plywood radiant barrier sheathing or an approved equal. Foil face side of the sheathing shall face attic.
- k. Roof sheathing shall be covered with at least 15# roofing felt. Galvanized D-drip edge shall be installed around roof edge perimeter. A ridge vent and a minimum of one wind turbine shall be installed as per manufacturer's recommendations on the roof sheathing prior to felt coverage. All roof pipe and metal vent penetrations shall be appropriately flashed, collared, capped and sealed prior to roof felt coverage. Roof shingles shall be 30-year architectural dimensional shingles with a light, neutral color to reflect heat.
- l. Exterior siding and trim cracks, seams and joints shall be caulked with an exterior 30 year latex caulk, and all exterior paint surfaces shall be primed and painted with a minimum of two coats durable exterior acrylic latex paint carrying a 30 year or more warranty.
- m. Front porches, rear porches and stoops shall be designed to provide ample cover and protection from inclement weather for the occupants opening the exterior doors.
- n. A 15-1/4" x 9-1/4" limestone address block with black numbers shall be installed in a conspicuous location on the front of the house, easily observed from the frontage street if a solid front brick, stone or stucco veneer is used. If siding is used on the front of the structure, a decorative brass address house plate (or approved equal) with minimum of 4" numbers shall be installed, and located as stated above.
- o. A lighted doorbell shall be installed at the front door location.
- p. Exterior decorative lights shall be installed at all exterior door locations and a front and rear 2-way flood light shall be installed under soffit corners to illumine the front, rear and side yards for security. Flood lights shall also be switched at nearest exterior door locations for easy access.

V. INTERIOR

- a. Structure shall be a minimum of 1,000 square feet of conditioned air space, or, upon approval of the City, may be smaller to accommodate lot requirements or the space needs and affordability requirements of the household.
- b. Single Family structures shall be a minimum of 2 bedrooms, 1-1/2 baths.
- c. Structure shall have a minimum of a one car garage or carport (unobstructed open space of 10' W x 20' L). In lieu of the garage, a storage structure or storage room may be substituted with a minimum unobstructed open area of 80 square feet and six foot width.
- d. Structure shall be equipped with a name brand HVAC split-system or heat pump, sized in accordance with applicable codes and carrying a minimum of 13 SEER rating.
- e. All interior walls shall be framed with 2" x 4" nominal size Temple® brand #2 southern yellow pine studs (or equal), with wolmanized sole plates and double top plates. Ceiling joists and rafters shall be sized in accordance with City codes and ordinances. Wet walls shall be sized to accommodate piping holes and notches in accordance with City codes and ordinances. Blocking shall be installed securely at all cabinetry and hardware locations.
- f. A folding attic stair or scuttle hole shall be installed in garage or hallway, sized to accommodate the replacement of largest equipment to be serviced in the attic space.
- g. All plumbing faucets and valves shall be builder grade or better, and finish of faucets and valves shall match finish of electrical fixtures and hardware in bathrooms and kitchen areas.
- h. All bedrooms and living room shall be equipped with cable TV and telephone jacks.
- i. Appliance spaces shall be Energy Star-rated, and mechanically fitted to receive either gas or electrical appliances at the stove, oven, water heater, dryer and air handler locations.
- j. An icemaker stop or recessed box shall be supplied to all refrigerator or ice maker locations.
- k. All vent-a-hoods requiring ducts shall be vented through the roof. Charcoal filter, non-vented vent-a-hoods are permissible.
- l. Kitchen sinks shall be a minimum of satin finish, stainless steel double basin, seven inches (7") deep with a one-half (½") horsepower food disposer.
- m. Flooring materials shall be strong and durable products carrying a minimum of 15 year warranty. Flooring products containing recycled materials are preferred. No long shag carpet shall be allowed. Ceramic tile or vinyl flooring is required in all wet areas.

- n. Exterior mounted instantaneous gas water heaters are preferred, but if not used, a well-insulated Energy Star rated 40 gallon tank heater is the required minimum.
- o. Dryers shall be vented out a side wall only...no venting upwards is allowed.
- p. Ceilings shall be a minimum of 8' (designed 9' vaulted, boxed or chamfered ceilings are encouraged).
- q. All bedroom and bathroom doors shall have minimum of KwikSet Valiant (equal or better) privacy knobs, closets shall have passage knobs, and exterior doors shall be keyed alike and equipped with a keyed entry knob and a keyed entry-single cylinder deadbolt lock.
- r. Kitchen counter tops shall be minimum quality of Wilson Art laminated plywood countertops with 4" or rolled backsplash. No pre-formed countertops shall be allowed.
- s. All bath lavatories, vanities, tub/shower and shower units shall be at minimum Lasco Fiberglass units or better.
- t. All kitchen and bath cabinetry units shall be, at minimum, Leedo Oakview units.
- u. Energy Star rated ceiling fans shall be installed in all bedrooms and living area.
- v. Hard-wired smoke detectors, wired in series, shall be installed in accordance to City codes. All smoke detectors shall sound off when one is activated.

EXHIBIT G

VOLUNTEER RELEASE AND INDEMNIFICATION AGREEMENT

I, _____, a volunteer work group member of _____ (Print Name)

_____, a Texas, Non-Profit Corporation, will be providing _____ (Non-Profit Agency)

Volunteer labor on the dwelling located at _____, Bryan, Brazos County, Texas. (Property Address)

I, THE UNDERSIGNED agree to and shall indemnify and hold harmless THE CITY OF BRYAN, its public officials, officers, agents and employees from and against any and all claims, losses, demands, judgments and causes of action of every kind and character including reasonable attorney fees, costs and expert fees, which may be asserted by any third party occurring or in any way incident to, arising out of, or in connection with the services and work to be performed. I understand that the City of Bryan is not responsible for the work being conducted on this project. I understand that the labor may involve a risk of injury to myself or others, and that the City of Bryan is not responsible for those risks nor does the City have any duty to mitigate those risks or make me aware of same. I understand that the City does not waive its governmental immunity, the limitations as to damages contained in the Texas Tort Claims Act or consent to suit. I hereby waive any claim I may have now, or that may arise in the future, against the City of Bryan arising out of or in connection with the services and work to be performed.

Signature of Volunteer Participant

Date

Printed Name of Volunteer Participant

TX Driver's License or ID #
(Required)

Home Address # Street City State Zip

Phone # Email

Multifamily Finance Division staff will place scanned copies of deficiency documents behind this tab in the application .pdf

Multifamily Finance Division staff will place scanned
copies of scoring notices behind this tab in the
application .pdf

Multifamily Finance Division staff will place documents related to Requests for Administrative Deficiencies behind this tab in the application .pdf

Real Estate Analysis Division staff will place scanned
copies of RFI documents behind this tab in the
application .pdf

Multifamily Finance Division staff will place scanned copies of appeal documents behind this tab in the application .pdf

Multifamily Finance Division staff will place scanned copies of public comment received behind this tab in the application .pdf

Multifamily Finance Division staff will place scanned copies of Commitment or Determination Notice documents behind this tab in the application .pdf

Multifamily Finance Division staff will place scanned copies of Direct Loan Program Award Letters behind this tab in the application .pdf

Multifamily Finance Division staff will place scanned copies of Carryover Allocation Agreement documents behind this tab in the application .pdf