

Photoelectric effect, a common fundamental error

This content has been downloaded from IOPscience. Please scroll down to see the full text.

1973 Phys. Educ. 8 382

(<http://iopscience.iop.org/0031-9120/8/6/005>)

View [the table of contents for this issue](#), or go to the [journal homepage](#) for more

Download details:

IP Address: 128.6.229.87

This content was downloaded on 10/12/2013 at 22:33

Please note that [terms and conditions apply](#).

beam. However it is not necessary to use laser light for the reconstruction and a small monochromatic source such as that formed by an iris diaphragm in front of a sodium lamp may be used. This method is not only safer but if only a low power laser is available yields brighter reconstructions. It is also instructive to observe the reconstructed image using a small white light source. Fine grain film holograms use relatively low spacial frequencies and thus have a small dispersive power compared with conventional holograms, so a quite well defined image may still be seen using white light and exhibiting coloured fringes.

As has been previously mentioned, the effects of external vibration are reduced to a minimum by mounting all components on a single optical bench. Further precautions to reduce vibration should also be taken.

(1) The optical bench may be mounted on rubber bungs and should be placed on a single laboratory bench or table.

(2) If the laboratory bench or table is free standing, it too may be further insulated by screwing rubber door stops under its legs.

(3) Although not experienced by the author, some shutters may give rise to appreciable vibration in which case they should be mounted off the optical bench in a retort stand which in turn is insulated in a manner similar to that of the optical bench.

(4) Common sense precautions should also be observed to cut down obvious sources of vibration such as running motors and people walking nearby. However, as exposure times are short this should not cause serious inconvenience.

Acknowledgment

The author wishes to express his thanks to Dr A Thetford of the Department of Physics, Reading University, for his willing advice and encouragement.

REFERENCES

Graham R W 1972 *Proc. Inst. Printing* 16
Williams G T and Owen T C 1967 *Physics Education* 2 278

Figure 4 Photographs of the reconstructed images from a complete hologram. Note that the zero order has been masked out and that the camera was focused on the virtual image



Photoelectric effect, a common fundamental error

A N JAMES

Oliver Lodge Laboratory, University of Liverpool

The results of experiments on the photoelectric effect commonly form the basis of the introduction of quantum phenomena in the teaching of physics. This approach is attractive not only because of the interesting historical associations but also because the photoelectric experiments demonstrate the properties elegantly and with a simple explanation. In the discussions of the experiments which are found in textbooks it is very common to encounter a description along the following lines.

The experiment performed with the apparatus of figure 1 is to shine light of frequency ν (energy quanta $h\nu$) on the metallic electrode A and to collect the photoelectrons emitted from the surface of A with another metallic electrode B (details of the geometrical construction are not important for the theoretical description of the phenomena but are important experimentally). The photocurrent I recorded on a low impedance current meter is measured as a function of the applied potential difference V measured by a voltmeter. The result of the experiment is recorded in the graph of figure 2. The voltage at which the photocurrent becomes zero is called V_s .

The most energetic electrons just outside the surface of A have an energy equal to the photon energy minus the energy necessary to pull an electron out through the surface of metal A (the work function $e\phi_A$ of metal A with ϕ_A measured in volts). The photocurrent becomes zero when these electrons have insufficient kinetic energy to overcome the electric field between A and B.

The argument then continues either explicitly or by implication to the equation

$$h\nu - e\phi_A = eV_s. \quad (1)$$

This equation is in fact not correct. The error is due to an inconsistent application of the work function concept. If the theoretical model being used to explain the photoelectric phenomena attributes a work function ϕ_A to metal A then it must also attribute a work function ϕ_B to metal B. The correct relation is

$$h\nu - e\phi_B = eV_s. \quad (2)$$

In a cursory examination of twenty different text books I have discovered that more than half of them are satisfied with equation (1). A disturbing feature of this survey is that the majority of the incorrect texts have publication dates later than 1960. A peak in the understanding of these phenomena occurred in the nineteen twenties and thirties after which interest in the details of real experiments declined. A significant renaissance, however, has occurred amongst research physicists using photoelectron spectroscopy as a tool (Siegbahn *et al* 1967).

It would appear that authors of incorrect texts have attempted to keep the complication of the explanation to a minimum. This strategy is poor in this case since it is no more difficult to give a correct treatment. A correct treatment also contributes positively to understanding the behaviour of electrons in metals.

The energy diagram given in figure 3 shows the potential energy of an electron as a function of position just inside and outside a metal surface. The energy levels of the conduction band are filled with electrons from the bottom upwards until the metal is electrically neutral. The electrons with maximum energy have an energy very close to the Fermi energy. The action of photons of energy $h\nu$ on the metal is that some of them are totally absorbed with a complete transfer of their energy to an individual electron. Provided the electrons have no further interaction with the metal they will escape through the surface and have a kinetic energy E just outside the surface. The value of E will depend on the energy level of the electron in the solid before the photon was absorbed. The distribution of numbers of elec-

Figure 1

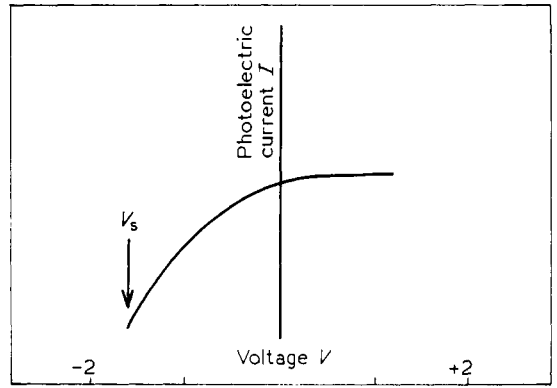
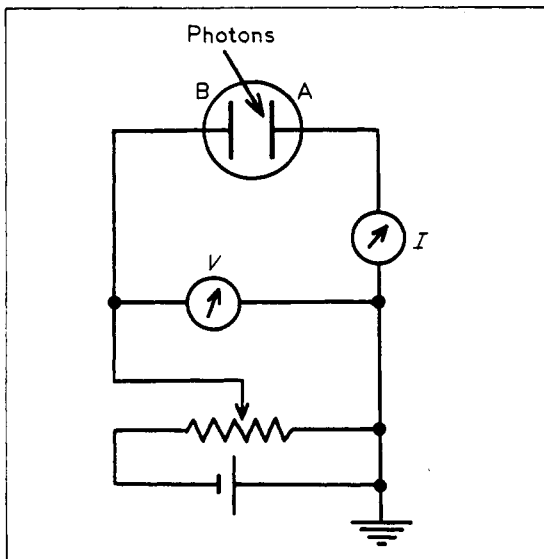

Figure 2

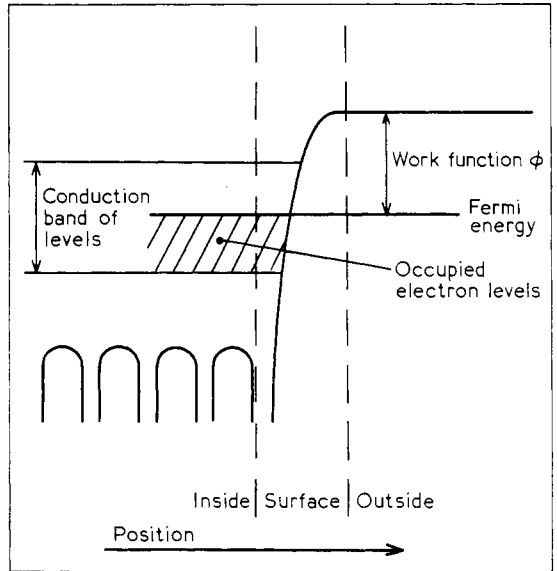
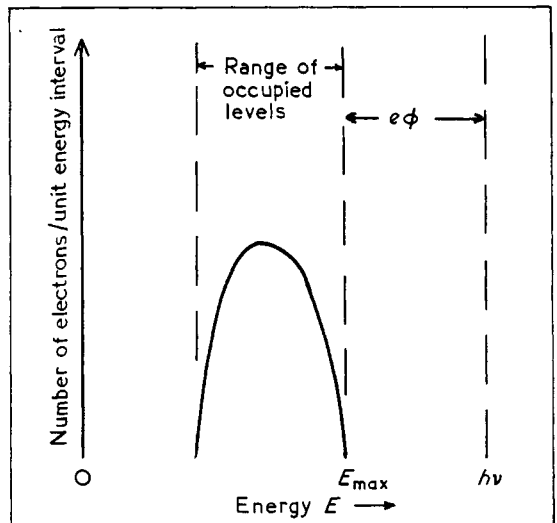

Figure 3

Figure 4



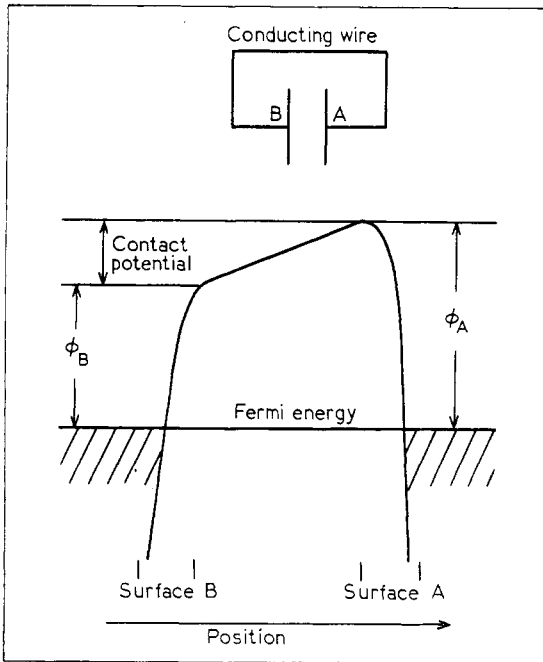

Figure 5

trons with energy E will be like that shown in figure 4. Secondary processes can easily reduce the electron kinetic energy but it is highly improbable that the energy will be increased above E_{\max} .

When two metals are connected electrically by a conducting wire a few electrons flow from one to the other until an equilibrium is reached where the maximum energy electrons in both metals have the same energy. If there are vacant levels in one metal below the energy of occupied levels in the other, electrons will move so as to occupy the lower levels; this charges one metal positively and the other negatively and raises or lowers the entire energy diagram (figure 3) of one metal relative to the energy diagram of the other metal. The resulting composite energy

Figure 6

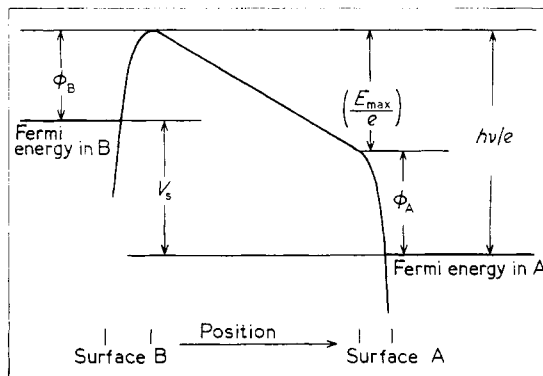

diagram showing the potential energy of an electron in the space between the two metals is shown in figure 5. In order that the potential may be a continuous function of position the potential changes smoothly from ϕ_B at one surface to ϕ_A at the other and there is an electric field between the metal plates A and B. The field is a consequence of the contact potential difference ($\phi_B - \phi_A$) of the metals and may be measured by vibrating plate A relative to plate B.

A voltmeter (such as in figure 1) reads the energy difference between the Fermi levels at its two terminals. This can be understood by imagining a battery generating exactly the voltage V indicated on the voltmeter, connected across the voltmeter; there is no current flow through the battery and electrons in the battery must be in equilibrium. An electron being forced from the positive plate of the battery to the negative plate gains potential energy eV . Since the electrons are in equilibrium throughout the battery electrons at the top of the occupied levels in one metal must correspond after passage through the battery with electrons at the top of the filled levels in the other metal.

An energy diagram corresponding to the potential V_s being applied between the two metals is shown in figure 6. At the surface of the metal B the kinetic energy of the most energetic photoelectrons just becomes zero. The kinetic energy E_{\max} is lost by the electrons in crossing from A to B by overcoming both the field due to the battery and the field due to the contact potential. Equation (2) is obvious and indicates that by repeating the experiment at different values of v both h and ϕ_B can be measured.

It is possible to discuss all the qualitative features of the photoelectric effect that lead to the idea of energy quanta without the detailed discussion of work functions given above. If one merely demands that removing an electron from a metal A uses up a certain energy $e\phi_A$ then photons have to be at least as energetic as this before the photoeffect releases electrons. An experiment where metal B is held at large positive voltage, to ensure collection of all photoelectrons, will detect photocurrent for light with a wavelength less than a certain critical value, but not for light of greater wavelength. This experiment measures the effect of ϕ_A but does not measure h .

Finally it is worth pointing out that the above discussion indicates that if the experiment measures ϕ_B then the metal surface which must be clean and have a uniform work function is that of metal B. Conversely if the experiment depends on ϕ_A then metal A must have a uniform surface.

REFERENCE

Siegbahn K *et al* 1967 'ESCA Atomic, Molecular and Solid State Structure' *Nova Acta. Reg. Soc. Sci. Upsal.* Series 4 20