

MANAGEMENT POLICY – QUALITY & ENVIRONMENT

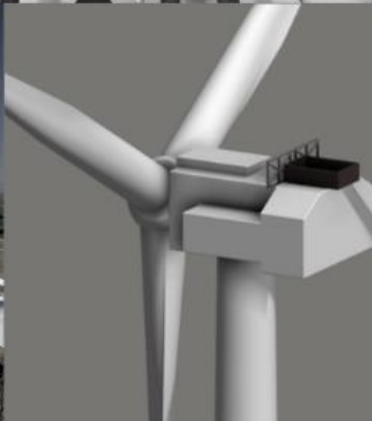

CORP-NWH-23-0003-R00

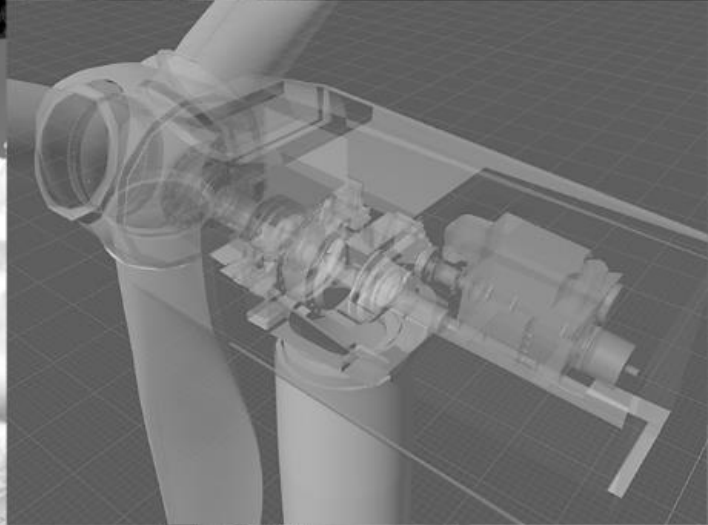

DOCUMENT DESCRIPTION

Client: NWH A.G.

Project: MANAGEMENT POLICY – QUALITY & ENVIRONMENT

Code: CORP-NWH-23-0003-R00

Section: Governance

Record of Changes: R00: 2023-09-19

- Initial Issue

PREPARED

Nabla Wind Power S.L.U.
Business Development

Nabla Wind Power S.L.U.
Proposals Manager

Nabla Wind Hub A.G.
Digital Communication Manager

CHECKED

Nabla Wind Hub A.G.
Head of Business Development

Nabla Wind Hub A.G.
Head of Finance

APPROVED

Nabla Wind Hub A.G.
CEO

TABLE OF CONTENTS

DOCUMENT DESCRIPTION.....	3
TABLE OF CONTENTS.....	4
MANAGEMENT POLICY – QUALITY & ENVIRONMENT	5

MANAGEMENT POLICY – QUALITY & ENVIRONMENT

Nabla Wind Hub A.G. is an independent engineering solutions provider for the wind industry specialized in Wind Assets' Optimization, through techniques that combine Life Extension, Performance Improvement and O&M Optimization.

Considering the need of assuring an optimal quality for all the activities developed inhouse, as well as committing to the respect for the environment, Nabla Wind Hub A.G. develops quality and environmental policies to achieve the goals of the company and to comply with the requirements of Stakeholders, based on the next principles:

- Improvement of the reliability and qualification of the team through internal and external trainings, and the implementation of new techniques and technologies, with the required accuracy for fulfilling our clients' needs.
- Respect the legal requirements and pre-established rules, as well as those set by our clients.
- Continuous dedication to improving our suppliers' quality standards. Assuring that quality is present in every aspect of the business.
- Commitment to improving continuously our organization management through an integrated quality and environmental management plan, using performance and goals indicators, as well as periodic reviews of the whole system, which will result on improving and reinforcing the efficiency and consistency of our company.
- Commitment to maintain an environmental management plan, devoting efforts to the protection of the environment (biodiversity and ecosystems) and the pollution prevention through a continuous improvement mindset.
- Clients' and Stakeholders' satisfaction, through the assurance of high-quality services. To achieve such objective, we will improve our process and services, always market-oriented being flexible to meet Client's requirements and specifications.

This policy has been approved by Nabla Wind Hub A.G.'s CEO, Carlo Durante, as of 19/09/2023. It will be reviewed periodically on an annual basis by the Head of Finance, Nelson Paquete, in order to include modifications and updates as necessary at the time, with the aim of improving its operation.

These policies will be available to all employees in the common media of all departments, in addition to the corporate website.

