

FLAT DILATOMETER MANUAL

by

Silvano Marchetti ^a

and

David K. Crapps ^b

^aVisiting Assoc.Prof. Univ.of Florida,Gainesville,Fla

^bSchmertmann & Crapps,Inc.,Consulting Geotechnical Engrs,Gainesville,Fla

June 8 , 1981

UNIT CONVERSIONS

1 mm = 0.0394 in
1 cm = 0.394 in
1 m = 3.28 ft

1 bar = 100 kPa = 1.044 tsf = 14.51 psi
1 kg/cm² = 98.1 kPa = 1.024 tsf = 14.23 psi

1 t (ton) = 1000 kg = 2205 lb

FLAT DILATOMETER MANUAL

INDEX

PART A. EQUIPMENT

CHAPTER

1.	GENERAL INFORMATION	
1.1	INTRODUCTION	1.1
1.2	PURPOSE OF THE INSTRUMENT	1.1
1.3	DESCRIPTION AND NOMENCLATURE	1.1
1.4	BASIC MEASURING PRINCIPLE	1.9
1.5	CHECKS TO CONFIRM CONDITION OF EQUIPMENT	1.11
2.	INSTRUCTIONS	
2.1	TEST PROCEDURE	2.1
2.2	DETERMINATION OF MEMBRANE CORRECTIONS ΔA AND ΔB	2.8
2.3	MEMBRANE MAINTENANCE AND REPLACEMENT	2.12
2.4	CHECKS BEFORE LEAVING FOR A SITE AND CHECKLIST	2.14
2.5	PERFORMING DMT WITH VARIOUS FIELD EQUIPMENT	2.19
3.	OFFICE MAINTENANCE	
3.1	DISASSEMBLING & CLEANING DILATOMETER TIPS	3.1
3.2	SERVICE OF DILATOMETER TIPS UPON RETURN FROM FIELD ..	3.9
3.3	SERVICE OF CONTROL UNIT UPON RETURN FROM THE FIELD ..	3.10
3.4	SERVICE OF PNEUMATIC-ELECTRIC CABLES UPON RETURN FROM THE FIELD	3.11
3.5	TROUBLESHOOTING GUIDE	3.13

PART B. RESULTS

4.	REDUCTION AND INTERPRETATION	
4.1	CHECK OF DATA BEFORE REDUCTION	4.1
4.2	DATA REDUCTION	4.2
4.3	CORRELATIONS FOR SOIL PARAMETERS	4.4
4.4	TIPS FOR THE REDUCTION OF DATA BY COMPUTER	4.6
4.5	COMMENTS ON DATA INTERPRETATION	4.8
4.6	RELIABILITY AND USABILITY OF PARAMETERS FROM DMT	4.11
4.7	PRESENTATION OF RESULTS	4.12
4.8	DATA SHEETS, SAMPLE CALCULATIONS, SAMPLE GRAPHS OF RESULTS	4.16
5.	ENGINEERING METHODS	
5.1	SETTLEMENT ANALYSIS BASED ON M	5.1
5.2	HORIZONTAL STRESSES AGAINST PILES DRIVEN IN SAND ...	5.8
6.	APPENDIXES	
6.1	DERIVATIONS OF THE FORMULAS FOR p_0 , p_1 , E_D	6.1
6.2	DERIVATION OF DRAINED CLAY MODULUS FROM UNDRAINED MEMBRANE EXPANSION	6.4
6.3	E_D AS A RELOADING MODULUS	6.7
6.4	SENSITIVITY IN M AND C_u DETERMINATIONS	6.9

PART A. EQUIPMENT

CHAPTER 1. GENERAL INFORMATION

1.1 Introduction

The Flat Dilatometer was developed in Italy by Silvano Marchetti, Prof. of Soil Mechanics at L'Aquila University. This manual describes the use of the Dilatometer, its care, theoretical background and correlations with geotechnical parameters, analysis of data and presentation of results. An extensive bibliography is provided for the interested reader.

1.2 Purpose of the Instrument

The purpose of the Flat Dilatometer is to determine insitu geotechnical parameters for engineering design. The instrument is usable in fine to coarse grained soils (clays, silts, sands) but is not suitable for gravels, where the results have no significance. (Often gravel lenses are recognized by a first reading A that is "too" low).

1.3 Description and Nomenclature

The equipment (see Fig. 1) consists of 3 main items:

1. Control unit (see Fig. 2)
2. Tips (see Fig. 3)
3. Pneumatic-electric cables (see Fig. 4)

and two additional auxiliary items:

4. Calibration device (see Fig. 5)
5. Tool box containing special tools (see Fig. 6)

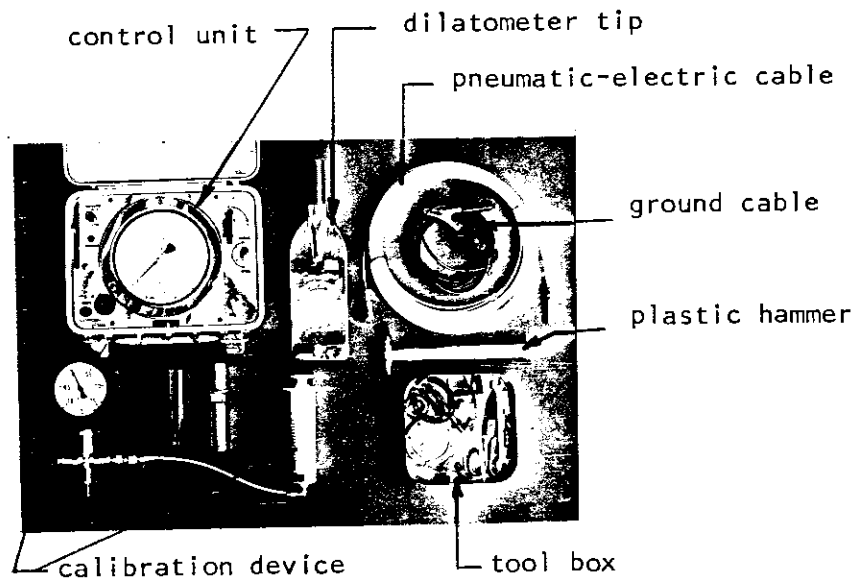

a. Dilatometer Components

FIGURE 1 COMPONENTS OF THE DILATOMETER EQUIPMENT

1.3.1. Control unit

Fig. 2 illustrates the various indicators and controls on the front panel. The following comments should be noted.

- a. Maximum operating pressure: the standard control unit is provided with a 40 bar capacity pressure gauge, suitable for most testing. However, when very weak soils are to be tested and if maximum accuracy is desired (as in research tests) it is better to replace this gauge with a more sensitive one having 16 bar capacity. The replacement is rapid and simple because the two gauges (both available from the manufacturer) have the same physical dimensions and the gauges are connected to the rest of the circuit with only one pneumatic connection.

On the other hand, when testing very strong soils (such as hard clay shales), the second reading B can exceed 40 bar and a gauge capable of 80 bar should be used. However, in this case a special control unit must be used that can retain and measure high pressures. Therefore the 80 bar capacity control unit with an 80 bar capacity gauge (available as an option from the manufacturer) should be used in such cases.

- b. Pressure source: in order to avoid damage to the gauge, the pressure source (usually reduced from a higher level with a pressure regulator) should always be less than or equal to the full scale of the gauge.
- c. Audio signal switch: should be off during storage periods and on during testing.

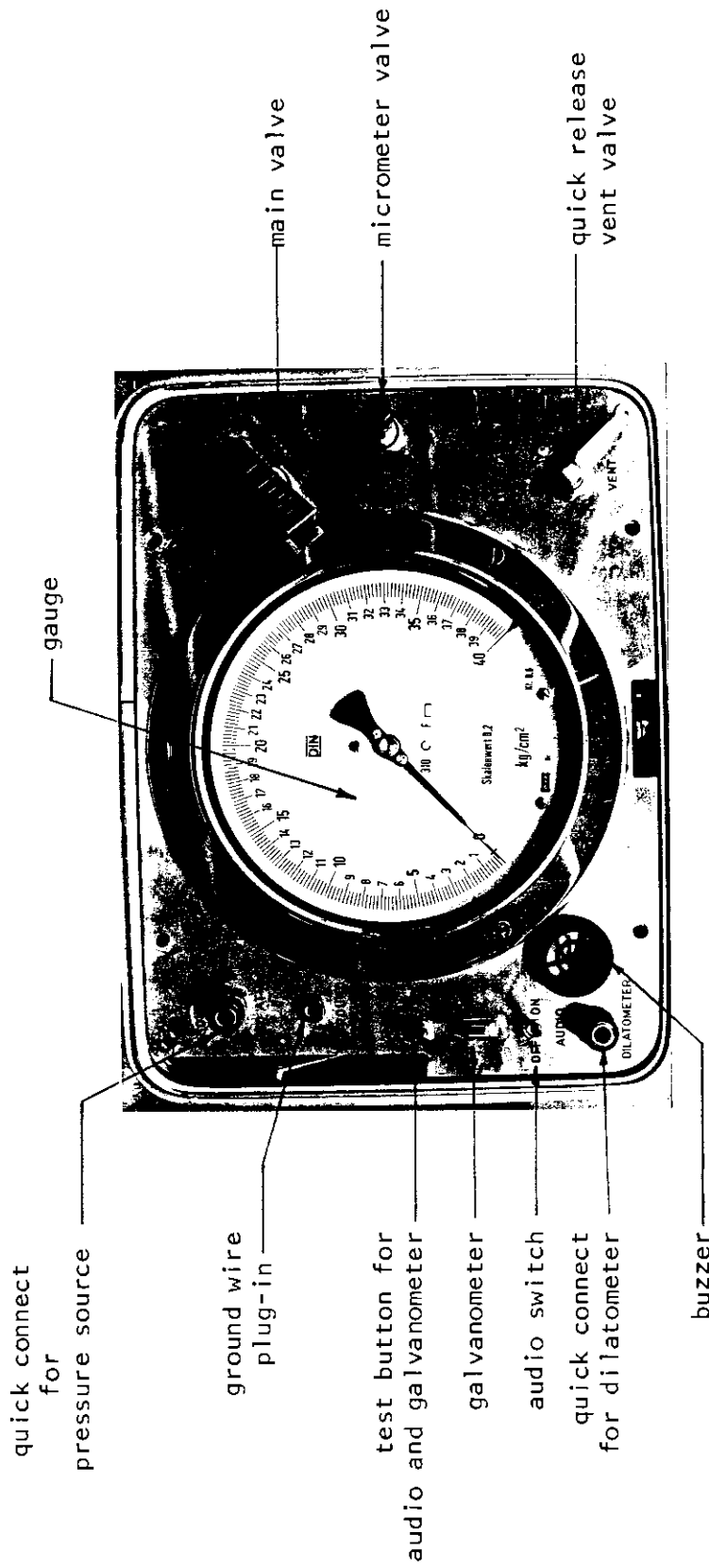

FIGURE 2 DILATOMETER CONTROL BOX

1.3.2. Dilatometer tips

Fig. 3 shows the dilatometer tip and rod adaptors used with CPT rods.

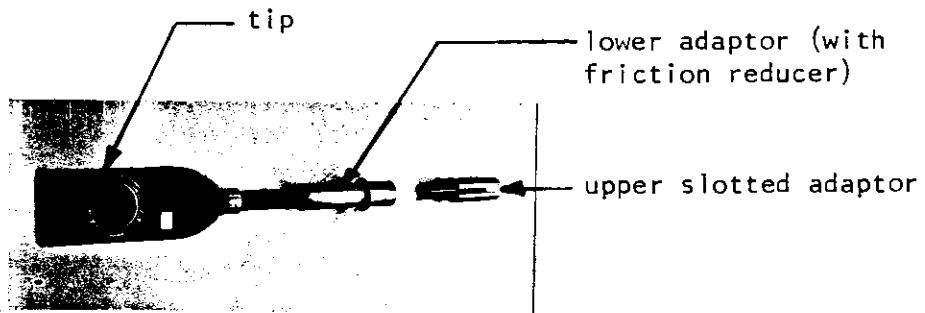

FIGURE 3 TIP AND ADAPTORS

1.3.3. Pneumatic-electrical cables

Three types of cable may be used:

- a. Non extendable: such as the one on the left hand side of Fig. 4a . Once the test depth is such that all the cable is inside the soil, the cable cannot be extended and the test must be stopped. This inconvenience is balanced by the simplicity of the cable and its lower cost.
- b. Extendable: such as the one on the right side of Fig.4a. Once all the cable is inside the soil, a new length of cable can be added. Note that the upper end of the extension cable is a female stainless steel terminal. This terminal cannot fit directly into the corresponding quick connector in the control unit. Therefore a short section of connector cable permitting such a connection (see next section (c.) and Fig. 4a) must be used in conjunction with this cable. This short adapter section is removed when a new cable is added (Fig. 4b).
- c. Short Connector Cable: differs from the type described in a. (non extendable) only by the length of the tubing, which is 10-20 cm (Fig.4a lower right). Its purpose is described in section b. above.

Short cables are easier to handle, but they require junctions. (Fig.4c). Junctions normally work very well and do not represent a problem as long as care is exercised to avoid all particles of soils getting into the conduits. For the same reason the terminals and connectors, when disconnected, must always be protected with the caps provided. (Fig. 4d).

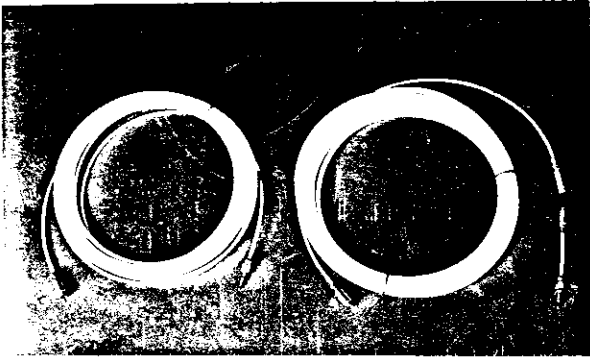

(a) Non-extendable Cable (left) and Extendable Cable (right) with Short Connector Cable (lower right)

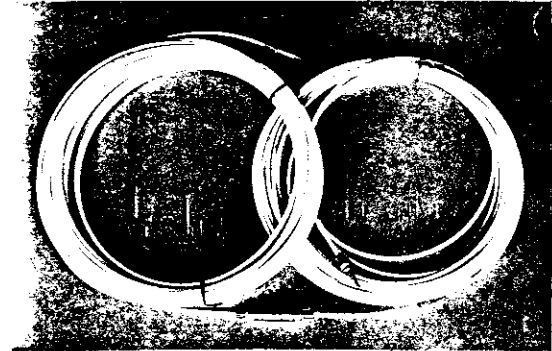

(b) Two Cables Connected Together

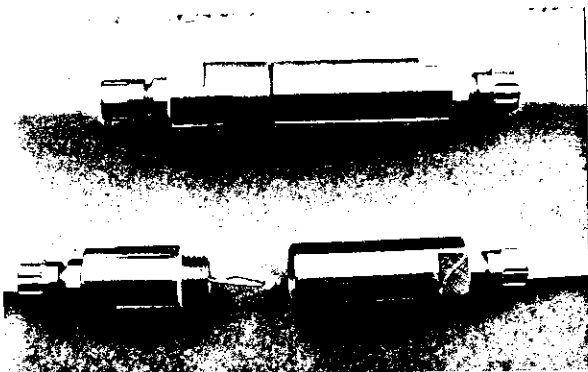

(c) Close^{up} View of Cable Connectors. Screwed Together (top) and Open (bottom) Showing Electrical Connector.

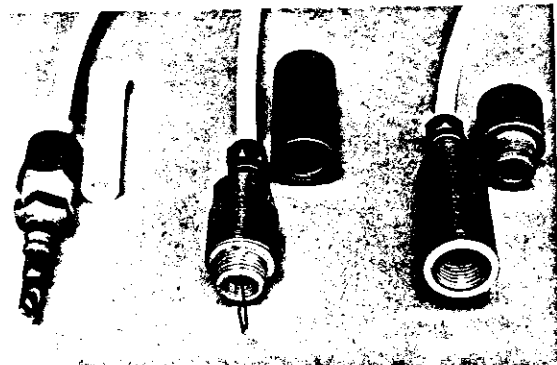

(d) Male Quick Connector (left), Male Stainless Steel Terminal (center) and Female Stainless Steel Terminal (right) with Protector Caps.

FIGURE 4 TYPES OF CABLES, CABLE CONNECTIONS AND CAPS

1.3.4 Calibration device

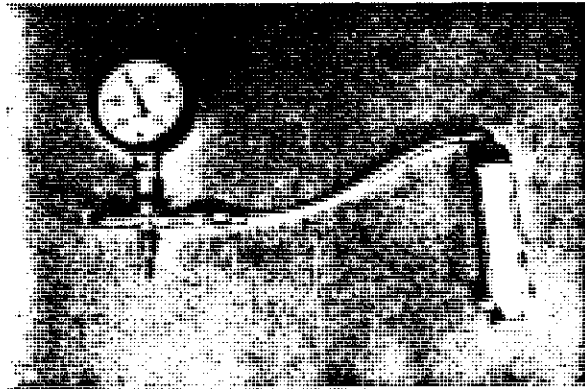

FIGURE 5 CALIBRATION DEVICE. Vacuummeter (left) and Calibration Syringe (right) Connected to Cross-Shaped Fitting.

1.3.5 Tool Box

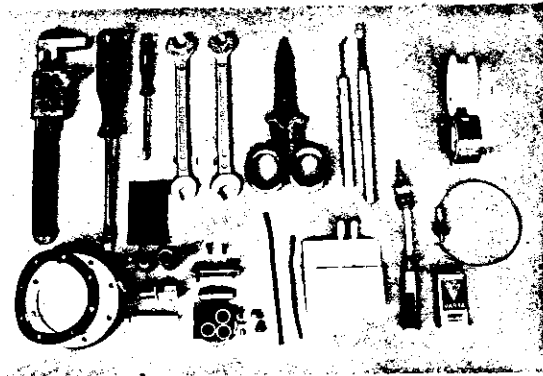

FIGURE 6 TYPICAL TOOL BOX CONTENTS

1.4 Basic Measuring Principle of the Instrument

Fig. 7 illustrates the basic measuring principle of the instrument.

The insulating seat prevents contact of the sensing disc with the underlying steel body of the dilatometer. The dimensions are such that the sensing disc is press-fitted and stationary inside the insulating seat. The sensing disc is grounded (and the control unit emits a sound) under one of the following circumstances:

1. The membrane rests against the sensing disc (as prior to membrane expansion).
2. The center of the membrane has moved 1 mm into the soil (thereby signaling the end of the dilatometer test). When the expansion is 1 mm, the springloaded steel cylinder makes contact with the overlying sensing disc.

There is no electrical contact and no sound during intermediate positions of the membrane. The illustrated dilatometer tip measuring system insures membrane expansion tolerances of ± 0.01 mm and cannot be varied by the operator.

Comments

- (a) The instrument works on a simple mechanical-electrical principle allowing rugged usage. However the parts of the instrument inside the membrane (disc, spring, metal cylinder, cylinder housing) must be clean to insure proper electrical contacts.
- (b) Only calibrated plexiglass cylinders (height 4.10 ± 0.01 mm) should be used to insure accuracy of the prefixed movement.

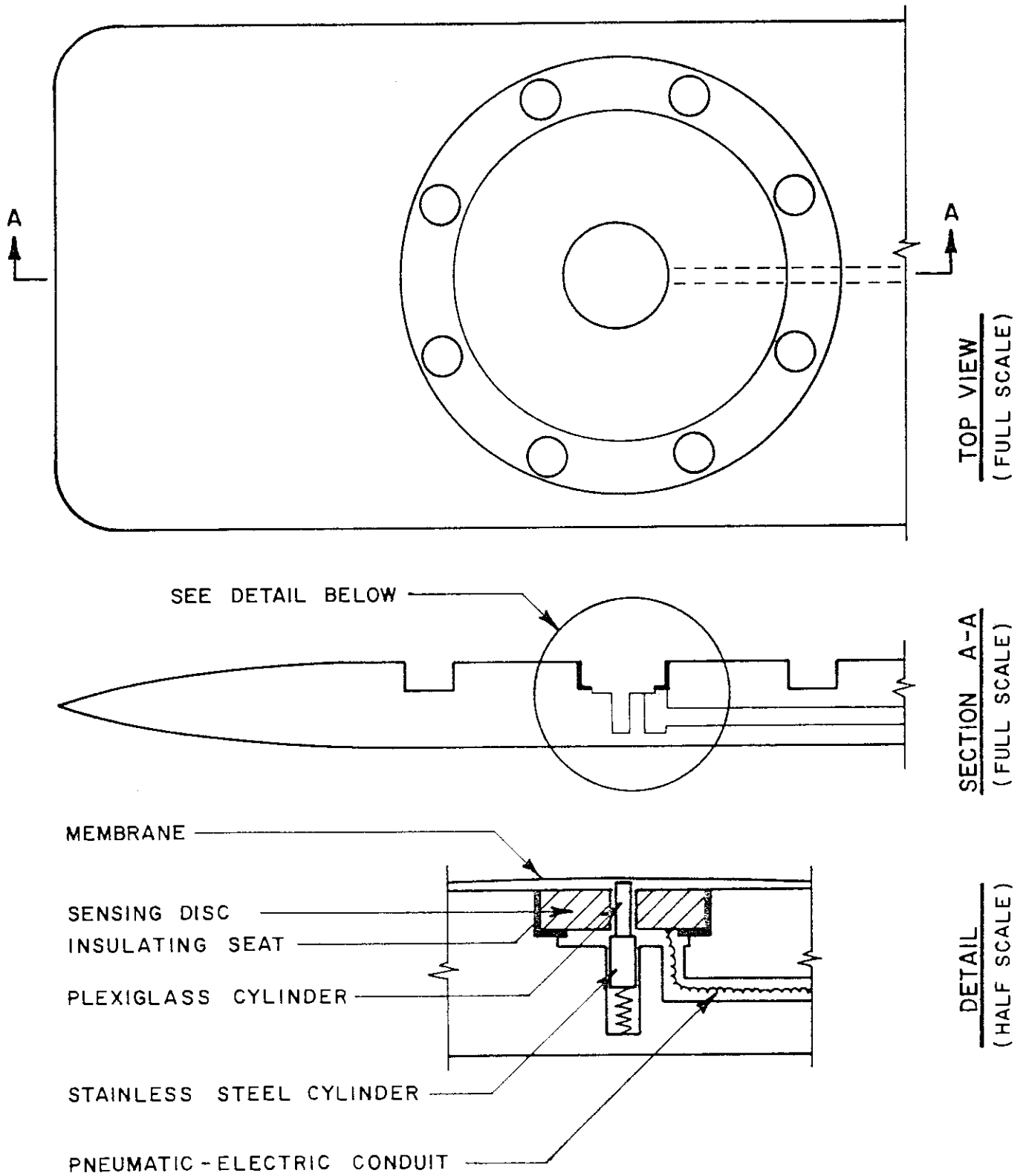

FIGURE 7
DILATOMETER TIP MEASURING SYSTEM

1.5 Checks to Confirm Condition of Equipment

The following checks should be performed to insure that the equipment has not suffered transportation damages. These steps are also useful to familiarize oneself with the equipment.

- a. General conditions: check the general conditions of the delicate items. These are the pressure gauge and the galvanometer on the front panel of the control unit and the pressure gauge of the calibration device. Inspect to make sure there is no obvious damage.
- b. Remove transportation screw: remove from the rear of the control unit pressure gauge the red transportation (copper) screw and replace it with the small plug screw. (Remove the large screws in the control unit to gain access to the back of the gauge).
- c. Zero of the gauges: insure that the zero of the gauge of the control unit Z_M is in the range of 0-0.4 bar (for a standard 40 bar control unit). To determine Z_M open the Vent valve and take a reading while tapping gently on the control glass. If $Z_M > 0.4$, Z_M should be reduced by turning the needle adjustment screw. This operation requires removing the control glass and is relatively delicate, and therefore should be performed by a suitable technician.

Similarly insure that the zero reading of the vacuomanometer (in vertical position) is nearly zero.

- d. Audio-visual signal: set the audio switch on the front panel of the control unit to the ON position. Press the push button on the front panel. The galvanometer should be activated and the buzzer should emit a sound.
- e. Proper functioning: a convenient way of insuring that the system is working properly is to perform the series of operations required to measure the membrane corrections ΔA and ΔB . The procedure is described in section 2.2. For this check it is convenient to use the shortest available cable. Remove the caps of the cable and connect all elements as shown in Fig. 9. Note that ΔA and ΔB do not need to exactly match the factory measured values written on the sticker on the dilatometer. However, they must be within the following ranges: $\Delta A = 0.15 \pm 0.05$ bar, $\Delta B = 0.4 \pm 0.3$ bar. Rectify the values on the sticker with the values determined by this operation. If difficulties are encountered, refer to section 3.5 (Troubleshooting Guide).

CHAPTER 2. INSTRUCTIONS

2.1 Test Procedure

2.1.1 Preliminary Operations

Connect the various elements of the equipment as shown schematically in Fig. 8, according to the following step by step procedure:

- a. Uncoil the pneumatic-electric cable making sure that there are no remaining twists in the cable that may result in kinks when the cable is stretched. Stretch the cable as straight as possible behind the rig used to install the dilatometer. The rods should be threaded onto the pneumatic cable and while one person holds the cable tight another person should slide the rods toward the rig, walking along beside the cable. The rods should then be stacked in a convenient manner for insertion by the rig. Make certain that the rods are threaded so that the proper connections are provided (both electric and pneumatic as well as between the rods). Experience has shown that it is better to walk the rods along the pneumatic electric cable rather than threading the electric pneumatic cable through the rods. During this operation the pneumatic electric cables should be protected from dirt with the caps provided.
- b. Insert the male quick connector of the pneumatic-electric cable into the female quick connector of the control unit.
- c. Insert the male stainless steel terminal of the pneumatic-electric cable into the threaded throat of the Dilatometer, making sure that the electrical hooked plug wire gets into the steel tablet inside the Dilatometer (Fig. 4c).
- d. Insert the electrical ground cable plug into the jack of the control unit. Attach the electrical alligator clip (on the other end of the electrical cable) to the upper slotted adapter at the top of the penetrometer rod.

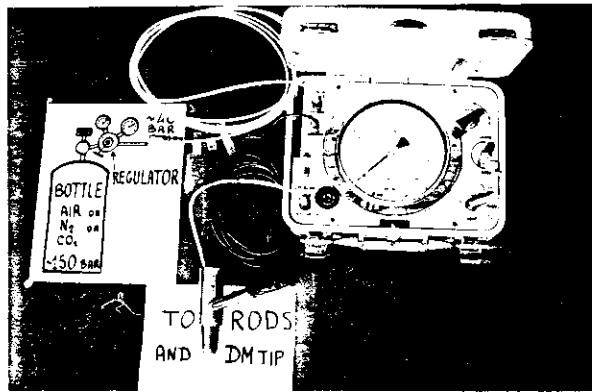

FIGURE 8 SCHEMATIC DIAGRAM OF DILATOMETER CONNECTIONS DURING TESTING

- e. Check to make sure that the electrical connections have been properly made. The galvanometer and the buzzer should activate when pressing on the center of the dilatometer membrane.
- f. Turn the valve designated "General" to the "0" position.
- g. Turn the Micrometer valve to the "0" position.
- h. Insert the pneumatic male quick connector coming from the pressure regulator (air, carbon dioxide, or nitrogen, maximum 40 bar in regular control units) into the control unit female quick connector marked "source".
- i. Adjust the pressure regulator (mounted on the pressure bottle so as to increase the output pressure up to a value equal to or less than the maximum capacity of the control unit (usually 40 bar)).
- j. Open the pressure regulator outlet valve to feed compressed gas into the control unit.
- k. Record the zero of the gauge Z_M (Z_M = reading at the gauge for zero pressure). To determine Z_M open the Vent valve and take a reading while tapping gently on the control glass of the gauge.

2.1.2 Current Test Procedure

- a. Push the dilatometer into the ground until the galvanometer and buzzer activate (this normally occurs 20 to 40 cm below ground surface). The test depth should be recorded with reference to the center of the membrane.
- b. Make certain that the Micrometer valve is closed. Open the General valve. During the rest of the test the General valve normally remains open.
- c. Slowly open the Micrometer valve so that the pressure monitored by the gauge increases slowly. When the galvanometer and the buzzer deactivate, write the first pressure reading, "A" (or memorize "A" if you are taking the readings alone).

- d. Continue applying pressure until the galvanometer and buzzer reactivate. At this moment do the following 4 operations: 1) Open the Vent valve which releases the pressure from the dilatometer, 2) Close the Micrometer valve which prevents further supply of pressure, 3) Signal the rig operator that he may begin advancing the dilatometer to the next test depth, 4) Write the second reading, 'B'. It is important that operations 1 and 2 be performed quickly after obtaining the reading. B. Otherwise, the membrane may be damaged.
- e. When the dilatometer has advanced to the next test depth (normally 20 cm below the previous test) close the Vent valve. Then repeat the above, beginning with item c. Note that during penetration the Vent valve must remain open to prevent damage of the membrane that would occur if the membrane remained inflated.

2.1.3 Remarks

- a. Pressures A and B must be reached slowly. The increase from 0 pressure to A should take approximately 15 sec. and increase from A to B an additional 15 sec. Note that the above time intervals result in very low pressure application rates for weak soils. These low rates are necessary to insure accurate results.
- b. If the soil is homogenous and the value of A predictable from previous readings the time interval from 0 to A may be decreased by using a faster rate of flow to a pressure level somewhat below A and then slowly reaching A for the last part of the interval. The time interval of 15 sec. between A and B instead should not be reduced substantially because this is the time during which the movement of the membrane and the soil is taking place. However, experience has shown that a variation by a factor of 2 in rate of pressure increase does not substantially alter the results.

- c. The time intervals given in a. and discussed in b. typically apply for cables lengths up to approximately 30 m. For longer cables the flow rate may have to be reduced to allow pressure equalization along the cable. The operator may check the adequacy of the flow rate that he has selected by occasionally closing the Micro-meter valve and observing how the pressure gauge reacts. If the gauge reading drops when closing the valve the operator is using too fast an application rate and it should be slowed.
- d. The alligator clip of the ground cable should be attached to the upper slotted adapter or to one of the pushrods and not to the metal frame of the rig (the frame of the rig is not always in firm electrical contact with the pushrods). When working in salt water it is usually sufficient that the alligator clip be simply immersed underwater to complete the circuit.
- e. If the dilatometer is advanced by driving, the vibrations could loosen the connection between the terminal of the cable and the dilatometer, letting water into it. In such cases, wrap the threads of the stainless steel terminal of the cable with teflon tape before tightening it into the dilatometer.
- f. Communication is important between the rig operator and the dilatometer operator. The two operators should position themselves so that they always have visual contact and can exchange control from one to the other. The rig operator must wait until the dilatometer test is complete and the dilatometer operator indicates "go" (meaning to advance to the next test depth). The dilatometer operator then has to wait until the rig operator signals that the next depth of test has been reached. It is important that the electrical connection be maintained throughout the dilatometer test or there is danger that the dilatometer operator may damage the

membrane due to lack of a signal. For this reason the rig operator should never attempt to add a section of rod which requires removing the electrical alligator ground clip during the test.

- g. The dilatometer operator should record a mark on the data sheet whenever a new rod is attached. The mark should be in a position intermediate between the depths before adding the rod and after adding the rod. This provides an additional check of the correctness of the recorded depths.
- h. Always leave the Vent valve open when leaving the dilatometer unit temporarily unattended so that, in case of a leaking feed valve, uncontrolled pressurization of the dilatometer may be avoided.
- i. Do not leave the dilatometer below the ground water table overnight if possible. A slight leak, unimportant in normal operations, may cause problems if it remains below the water table for an extended period of time.
- j. A test button is provided adjacent to the galvanometer which enables the operator to check the condition of the battery and galvanometer to make sure they are working properly. If the battery is low replace it with a new one (9V).
- k. The galvanometer is much more sensitive than the buzzer. Therefore when the excitation voltage is low (e.g. low battery, long lines, etc.) the sound of the buzzer may be inaudible, but the galvanometer still provides a well defined signal.
- l. The operator should always insure an adequate supply of gas in the field to last during the estimated testing interval. Gas consumption may be estimated as follows: a 10 liter bottle charged to 150 bars is sufficient for about 200 m of testing with readings every 20 cm in a soil of *medium* consistency and 30 m of tubing. The consumption increases with tubing length and with pressure B.

- m. Make certain that the terminals of the pneumatic-electric tubing are clean. Check to make certain that the small holes in the cylindrical pvc plugs inside the connectors are free of dirt. A small brush and a needle probe are convenient tools to clean the connectors while holding them in a downward position.
- n. It is very important that the rig operator tighten the rods to the point that they shoulder properly. Normally if the rods are free from rust and soil, hand tightness is adequate. However, in some cases wrenches may be required to insure the proper contact. If a gap is left between the rods there is a great danger of the rods breaking at the threads thereby resulting in loss of the dilatometer tip.
- o. A needle valve located inside the control unit is provided in series with the Micrometer valve. This needle valve is preset at the factory so that the pressure increases from 0 to 20 bars in approximately 7 to 8 sec when using a 30 m cable and with the Micrometer valve fully open. This needle valve may be adjusted if the operator determines that it is convenient to have a faster flow rate.
- p. The pressure inside the quick connectors must always be vented before disconnecting them, otherwise the O-ring inside the female quick connector can be blown out and lost. If the old O-ring can be located it may be replaced in its seat. Otherwise it may be necessary to replace the female quick connector. Warning: disconnecting quick connectors under pressure can be dangerous, resulting in serious injury or loss of sight. Therefore, always first vent the pressure before disconnecting.

2.2 Determination of Membrane Corrections ΔA and ΔB

2.2.1 Background

ΔA is the external pressure (or internal vacuum) required to keep the membrane in contact with its seating. ΔB is the internal pressure which lifts the membrane center 1 mm in free air.

Experience has shown that ΔA does not vary appreciably ($\Delta A \approx 0.15 \pm 0.05$ bar). However, ΔB does vary appreciably with the condition of the membrane and can be as high as 2 bar for a new membrane. Use of the membrane results in a decrease of ΔB tending to decrease at a faster rate when new and at a slower rate with use. ΔB generally stabilizes at a value in the range 0.4 ± 0.3 bar. When a new membrane is installed, it is necessary to exercise it in order to decrease ΔB to a value within the above range so that no further appreciable variation occurs during the sounding. The membrane corrections ΔA and ΔB must be determined accurately because they are used to correct all the readings of a sounding. Their accurate determination is particularly important in very weak soils where ΔA and ΔB may be an appreciable fraction of the readings. In order to achieve the required accuracy, ΔA and ΔB must be determined both before and after each sounding.

If for some reason (e.g. breakage of the membrane) field determinations of ΔA and ΔB are not possible then the average values $\Delta A = 0.12$ and $\Delta B = 0.4$ bars may be used to reduce the data. However while these average values may be acceptable in relative stiff soils ($E_D > 50$ bar), they can introduce appreciable errors in weak soils.

2.2.2 Procedure

1. Make certain that the pneumatic tubing from the pressure bottle is disconnected from the control unit. The control unit must be vented (open the vent valve for at least 10 secs.) from high pressure that would damage the vacuo-manometer.
2. Close the "General" valve.
3. Connections: Arrange the connections between the control unit, the dilatometer tip, the pneumatic cable, the calibration device and the ground cable as shown in Fig. 9.

In particular, note that:

- a. The calibration device is inserted into the front female quick connector of the control unit (not into the quick connector marked "Source!").
 - b. The ground cable should have one end (the plug) inserted into the jack of the control unit and the alligator clip connected to the dilatometer.
4. Open the Vent valve.
 5. Push the piston completely into the syringe.
 6. Close the Vent valve.
 7. Quickly retract (in one or two sec) the syringe piston as far as possible (near to the rim) in order to apply the maximum vacuum possible.

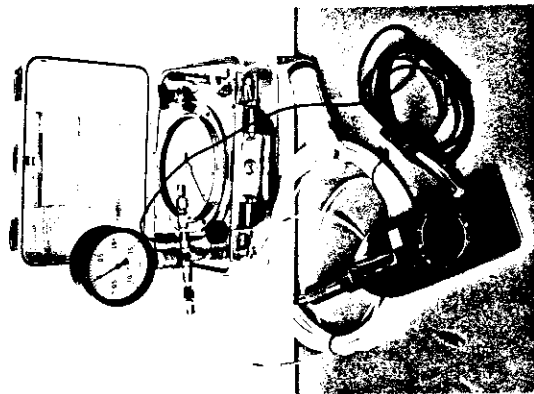
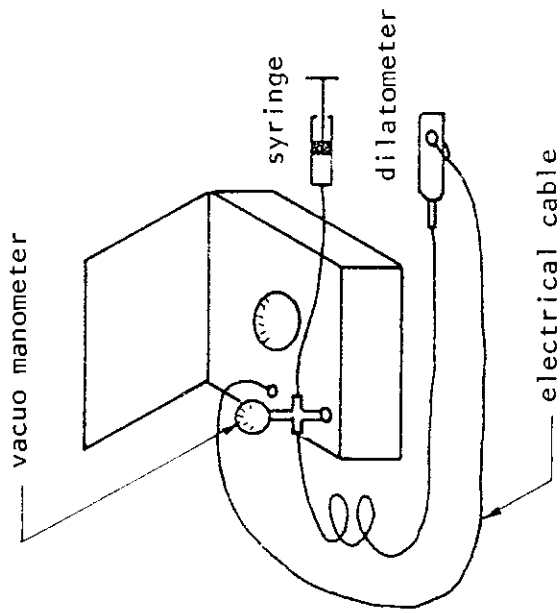

FIGURE 9 SETUP FOR MEMBRANE CORRECTION DETERMINATION. (Note dilatometer pneumatic- electric cable, calibration syringe and calibration gauge connected to calibration "cross". Also note electrical ground cable hooked to dilatometer).

8. Hold the piston for sufficient time (at least 10 sec) for the vacuum to equalize in the system. During this time the galvanometer and buzzer should be activated.
9. Slowly (this operation should last 10 to 20 sec) let the piston go down thereby releasing the vacuum and note the vacuum at which the galvanometer and buzzer are deactivated. Note this vacuum as a positive ΔA value (e.g. a vacuum of .15 bar should be reported as $\Delta A = 0.15$). The equations take into account the sign of this pressure.
10. Repeat two or three times steps 4-9 for ΔA . Record for ΔA a suitable average.
11. Open the Vent valve.
12. Retract the syringe piston as far as possible (near to the rim).
13. Close the Vent valve.
14. Push the piston slowly (this operation should last 10 to 20 sec) into the syringe thereby increasing the pressure up to the point that the galvanometer and buzzer are activated. Note this pressure as ΔB .
15. Repeat two or three times steps 11-14 thus obtaining various determinations of ΔB . Record for ΔB a suitable average.
16. ΔA and ΔB are considered normal if they are within $\Delta A = 0.15 \pm 0.05$ bar and $\Delta B = 0.4 \pm 0.3$ bar.
17. If ΔA is too high (more than 0.20 bar vacuum needed to retract the membrane) refer to the Troubleshooting Guide, item 3.5.1d. If ΔB is too low or negative refer to Note a. at the end of section 3.1. If ΔB is too high the membrane must be exercised (Refer to section 3.1.12).

2.3 Membrane Maintenance and Replacement

2.3.1 Possible Damages to the Membrane

- a. The Membrane needs to be replaced when it is torn, severely wrinkled, or overstressed. In all cases the necessity of changing the membrane will be apparent from the anomalous values of ΔA and ΔB . Therefore, if the operator is unsure about the condition of the membrane he should recheck ΔA and ΔB values. The need for replacement of torn membranes is usually apparent. Severely wrinkled membranes are defined as those with "dimples" or sharp bends affecting an area of 1 mm or more. Overstressed membranes are those whose permanent curvature is so pronounced that they emit a snapping sound when pushed and released.

It is unusual to tear a membrane when testing normal strength clays, silts and sands and one membrane can accomplish several hundred meters of testing. However, dense coarse sands produce wrinkles in the membrane resulting in its replacement at 100 m or less of testing. Sharp edged stones can cause membrane tearing. Smooth gravel usually does not produce membrane tearing. However, the dilatometer is not suited for testing gravel materials.

Maximum care must be exercised to avoid damaging the membrane by excessive inflation beyond the second reading (B). If the membrane is overinflated, this would alter ΔA and ΔB . The altered ΔA and ΔB values will be apparent only upon checking after the sounding is over. Therefore, in soft soils accurate results cannot be obtained if the membrane has been overstressed at one or more elevations during a sounding. One can be sure of maximum accuracy in weak soils only when the before and after test ΔA and ΔB values are similar (up to 0.2 bar difference between the before and after test $\Delta A + \Delta B$ sum).

2.3.2 Membrane replacement

When the membrane needs to be replaced but the nature of the damage (or of the soil) is such that no water or mud has entered beneath the sensing disc, the membrane can be easily replaced in the field. The steps

to be performed are part of those listed in section 3.1 describing the full disassembling and cleaning procedure. They are:

- a. Remove ring (see Step 1 in section 3.1)
- b. Remove membrane (see Step 2 in section 3.1)
- c. Carefully clean all exposed parts
- d. Make sure the plexiglass cylinder is in place
- e. Reassemble membrane and ring (see Step 10 in section 3.1)
- f. Check air tightness (see Step 11 in section 3.1)
- g. Exercise membrane (see Step 12 in section 3.1)
- h. Determine ΔA and ΔB (see section 2.2)
- i. Mark ΔA and ΔB on sticker (see Step 14 in section 3.1)

If the inside of the dilatometer is full of mud and water, it should be returned to the office for full service. Such service must be performed by a technician familiar with the instrument and Chapter 3 of this manual (Office maintenance).

2.4 Checks Before Leaving for a Site and Checklist

2.4.1 Checks before leaving:

- a. Use the checklist in the next section (2.4.2) to insure that the equipment is complete. Mark the quantity of each item on the checklist. Retain a copy to be used when the equipment is returned to the office.
- b. Make sure that the thread of the lower adapter and the thread of the tips match. Do this check by tightening them completely. Use a metal brush to remove dirt or rust from threads.
- c. Measure the corrections ΔA , ΔB of each tip. Record them on the checklist and rectify the values on the sticker attached to the tips if appropriate. This operation, besides supplying updated values of the corrections, is an additional check of the proper working conditions of the tips.
- d. If the pressure bottle is procured by the people at the site, be sure that sufficient information is exchanged between the office and the site so that the regulator of the Dilatometer equipment will fit into the pressure bottle outlet. Alternatively a pressure regulator of appropriate capacity and fitting to the bottle outlet can be procured by the people on the site. However in this case the pressure line from the regulator must end with a fitting that can be readily connected with the pressure line to the control unit (Fig. 8).
- e. Make sure that the rig on the site has sufficient rods (= maximum test depth + a few m sticking out of the ground) and spare rods. If rods other than CPT rods are used, appropriate upper and lower adapters must be available (Fig. 10).
- f. An evaluation of the maximum test depth that can be reached by pushing the Dutch cone CPT rods with the friction ring (if no obstructions are found) is possible based on the following information:
 - (22 kips)
 - Max reaction 10 t, in stiff clay or loose to medium sand:
10 to 20 m
 - (11 kips)
 - Max reaction 5 t, in NC clay: 30 m

(a) LOWER ADAPTOR FOR SPT RODS

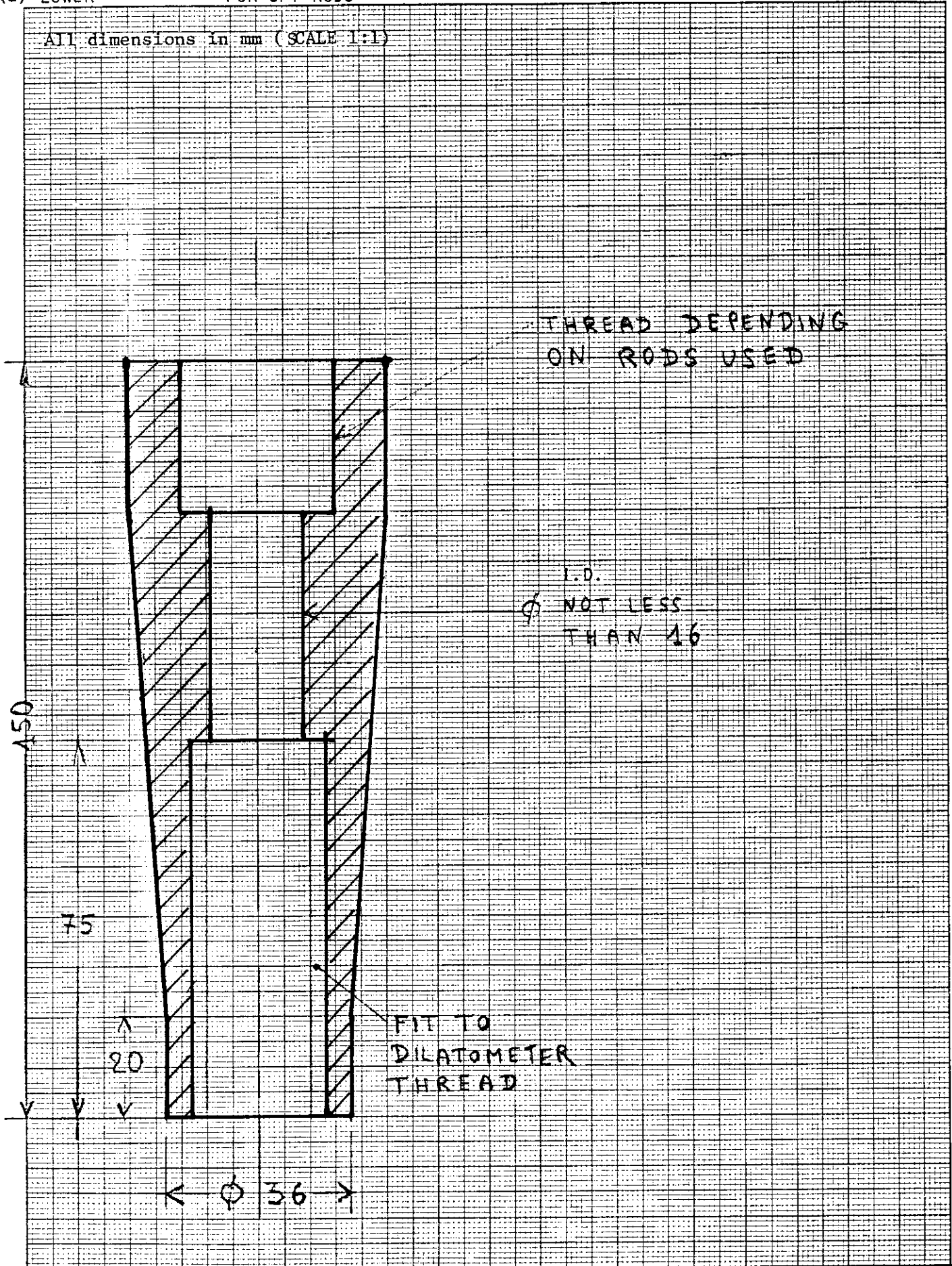

(b) SLOTTED ADAPTOR FOR SPT RODS

SECT. AA

All edges well rounded

All dimensions in mm (SCALE 1:1)

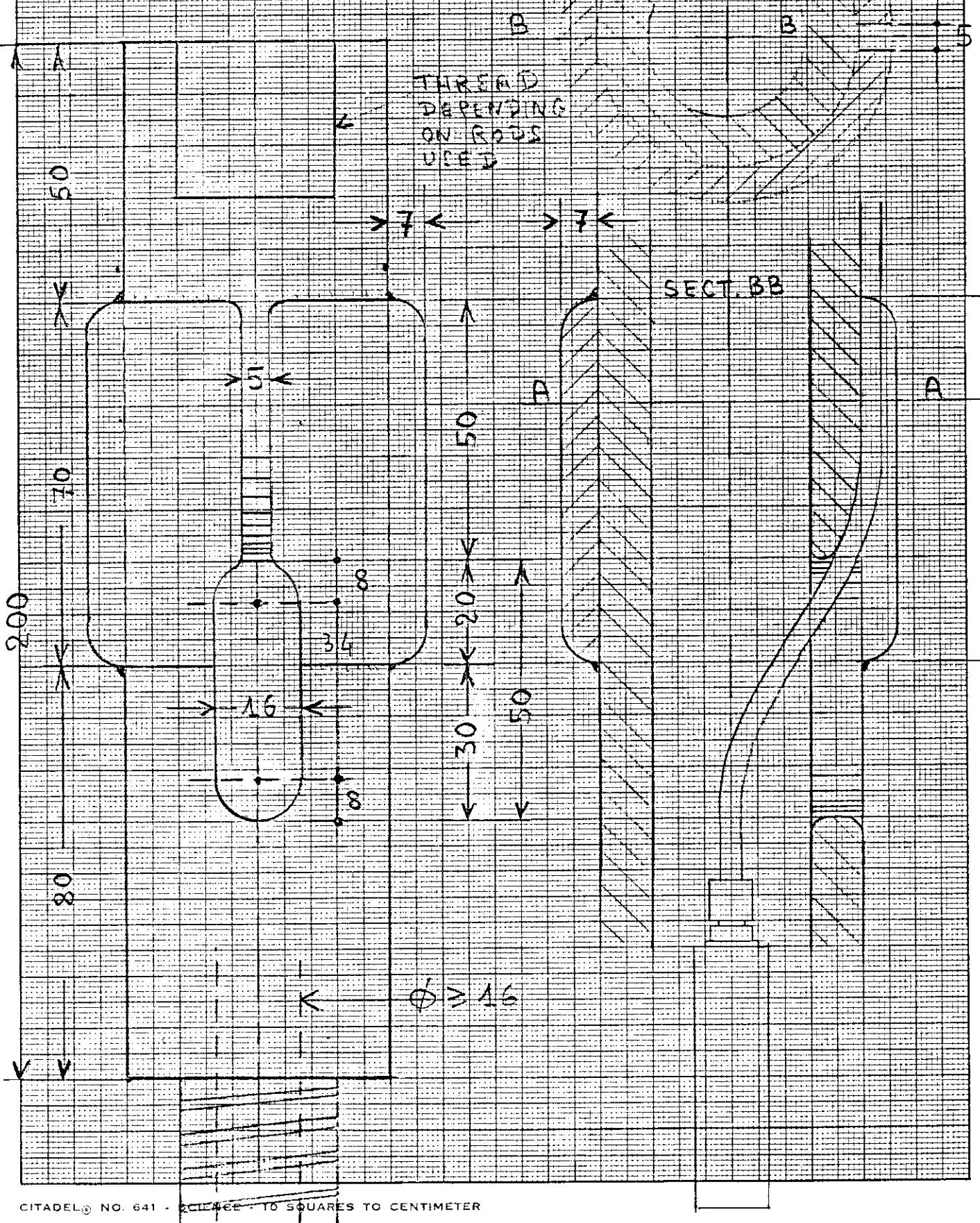

2.4.2 Dilatometer Check List

Item Number	Item Description	Suggested Number	Actual Number
Items in carrying case			
1.1.	control unit	1	_____
1.2.	dilatometer tips (record serial no)	2	_____
1.3.	pressure regulator	1	_____
1.3.1	regulator tubing (4 meters long)	1	_____
1.4.	pneumatic-electrical cable	[as needed	_____
1.4.1	short pneumatic-electrical connector cable		_____
1.5.	electrical ground cable (4 meters long)	1	_____
1.6.	upper slotted adaptor	2	_____
1.7.	lower adaptor	2	_____
1.8.	data sheets	≥ 10	_____
1.9.	user's manual	1	_____
1.10.	tool box (see below for contents)	1	_____
1.11.	calibrator (plastic syringe + vacuomanometer)	1	_____
1.12.	plastic hammer	1	_____
1.13.	adjustable wrench	1	_____
1.14.	large metal syringe (optional)	1	_____
Items in tool box			
1.10.1	small screwdriver	1	_____
1.10.2	large screwdriver	1	_____
1.10.3	11 mm wrenches	2	_____
1.10.4	puller for removing sensing disc	1	_____
1.10.5	scotch tape	1	_____
1.10.6	q-tips	3	_____
1.10.7	tissue paper	3	_____
1.10.8	gasket for membrane	1	_____
1.10.9	membranes	8	_____
1.10.10	small plexiglass box (see next page for contents)	1	_____

Item Number	Item Description	Suggested Number	Actual Number
1.10.11	spare female quick connector	1	_____
1.10.12	scissors	1	_____
1.10.13	tie wires	6	_____
1.10.14	small brush	1	_____
1.10.15	spare 9V battery	1	_____
1.10.16	spare male plastic protector	1	_____
1.10.17	spare female plastic protector	1	_____
1.10.18	spare transparent covers for male connectors	3	_____
1.10.19	special tool to remove threaded inner-plastic retainer cylinder from inside dilatometer throat	1	_____
1.10.20	fine sand paper	8	_____
1.10.21	tweezers	1	_____
1.10.22	needle probe	1	_____
1.10.23	teflon ribbon		_____
Items in small plexiglass box			
1.10.10a	spare retaining ring screws	2	_____
1.10.10b	spare nylon washers	3	_____
1.10.10c	plexiglass spare cylinders	3	_____
1.10.10d	stainless steel spring	1	_____
1.10.10e	small stainless steel cylinder	1	_____
1.10.10f	brass ferrules for control unit	not indispensable	_____
1.10.10g	spare screws for puller	2	_____
2.	pressure cylinders	≥ 1	_____

Additional tools (normally left in the office)

- Teflon sheet for lifting sensing disc
- Tripod with dial gauge for checking tolerances
- Closed terminal for pressurizing cables

Options

- Large metal syringe
- Gauge 16 bar
- Gauge 80 bar

2.5 Performing DMT With Various Field Equipment

Fig. 11 shows various methods of advancing the dilatometer. In Fig. 11 (a) and (b) the dilatometer is pushed. In Fig. 11 (c) and (d) the dilatometer is driven. If it is possible to choose methods of penetration, quasi static penetration is preferred over dynamic penetration.

If the soil is penetrable and the site is accessible, by far the most effective equipment for performing the DMT is a CPT truck (Fig. 11 a). This equipment greatly reduces the delay time between the end of one sounding and the beginning of the next. This delay time encountered with other types of equipment is often an important proportion (if not the largest) of the total testing time. When obstructions are anticipated, a conventional drill rig may be the best solution since, it is required anyway to get past the obstruction. (Fig. 11b). However, the pushing capability of the drill rigs is usually limited to no more than 2 or 3 t due to the eccentricity of the reaction and only a penetration of a few m below the bottomhole can be expected.

Fig. 11 (c) and (d) illustrate dynamic penetration of the Dilatometer. Fig. 11 (c) shows an arrangement making use of the widely used SPT equipment. Fig. 11 (d) shows the use of a light equipment whose dimensions and weight are interesting when testing in sites of difficult access. Fig. 12 shows DMT performed offshore from barge, with the dilatometer driven using the SPT hammer.

DMT PERFORMED WITH STANDARD FIELD EQUIPMENT

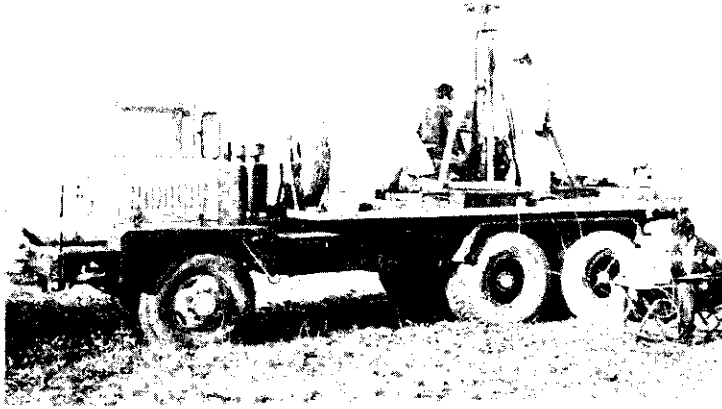

(a) DILATOMETER PUSHED BY CONE PENETRATION TEST EQUIPMENT

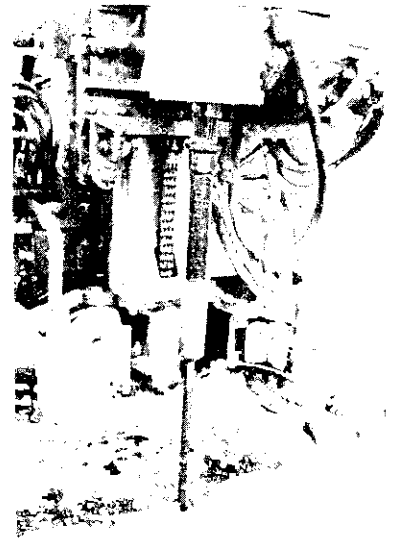

(b) DILATOMETER PUSHED BY HYDRAULIC JACK OF DRILL RIG

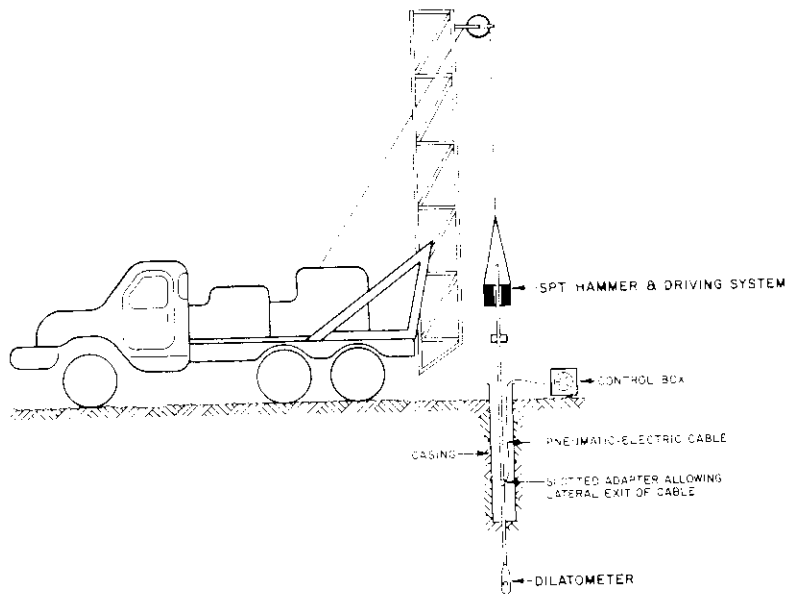

(c) DILATOMETER ADVANCED WITH STANDARD PENETRATION TEST EQUIPMENT

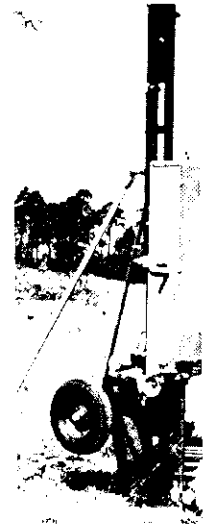

(d) DILATOMETER ADVANCED BY LIGHT WEIGHT RAM SOUNDING APPARATUS

DMT PERFORMED OFFSHORE FROM BARGE

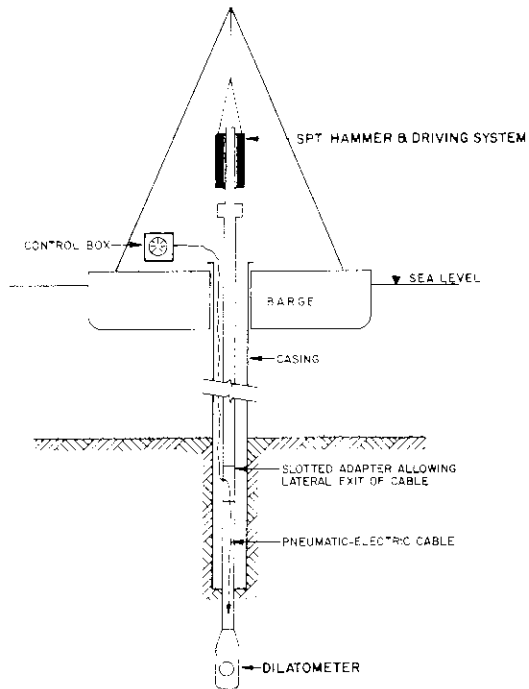

Offshore applications of the DMT have been made in water depths up to 30 meters to total depths of 60 meters. The dilatometer is usually advanced up to 4 meters below the casing tip before advancing the casing. Individual tests are made at 20 cm intervals thereby providing a nearly continuous profile of soil properties.

(a) DILATOMETER ADVANCED BY STANDARD PENETRATION TEST EQUIPMENT FROM BARGE



(b) TECHNICANS PREPARING TO INSERT DILATOMETER INTO CASING THROUGH BARGE

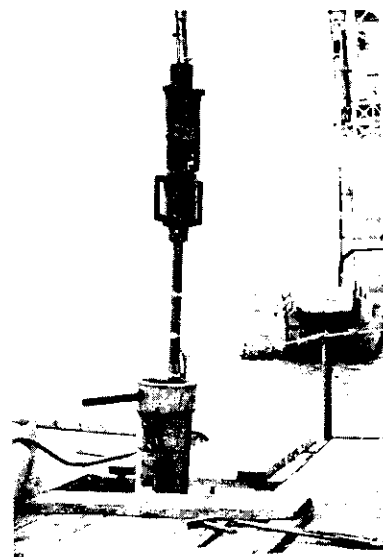

(c) SPT HAMMER ADVANCING THE DILATOMETER SHOWN IN PHOTO TO LEFT

CHAPTER 3. OFFICE MAINTENANCE

This Chapter starts with the complete step-by-step procedure to be applied in its entirety when a dilatometer needs to be cleaned internally or to be checked. Note however that in many cases only some of these steps are needed to solve a particular problem (see e.g. section 2.3.2 on membrane replacement) or to check dilatometers upon return from the field (see section 3.2).

3.1 Disassembling and Cleaning Dilatometer Tips

1. Remove ring: Clean the probe and remove the desiccated soil from the slot of the screws using the small screwdriver and the brush (Fig. 13a). Remove the 8 screws from the retaining ring with the large screwdriver. Note that there are 2 threaded holes through the ring into which the same screws may be screwed to be used as ring pullers (Fig. 13b). If necessary tap on the ring with a plastic hammer to break the desiccated soil. Remove the ring and clean carefully.
2. Remove membrane: The small screwdriver may be used to gently pry around the edge of the membrane, being careful not to damage the gasket while the membrane is loosened. Then lift out the membrane. Make certain that the small plexiglass cylinder (Fig. 13d) is not lost in the event that it comes out with the membrane. Replace the membrane if necessary. Use the membrane for holding all the small components as they are removed.
3. Remove sensing disc: Place the special pulling tool over the sensing disc (Fig. 13c). Screw down the two small (inner) screws into the disc (make certain that the proper length screws are used to insert into the sensing disc, otherwise the "half moon-shaped" spring underneath the sensing disc will be damaged). During extraction prevent the insulating seat from lifting by pressing down with a screwdriver.

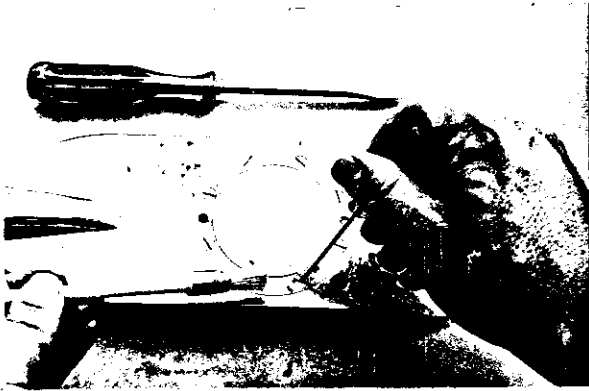

(a) Remove All Soil Around Screws & Then Remove 8 Screws Through Retaining Ring.

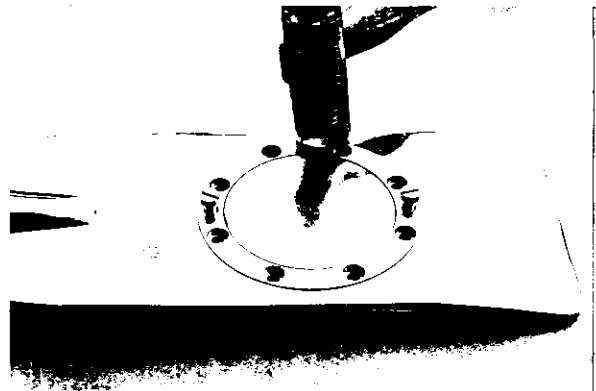

(b) Place Two Screws in Threaded Holes in Retaining Ring. Tap Ring Lightly, and Then Remove Ring by Lifting Up on Screws.

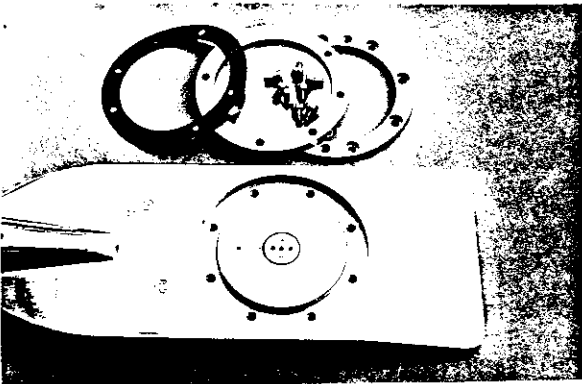

(c) Remove Retaining Ring, Membrane, and Gasket.

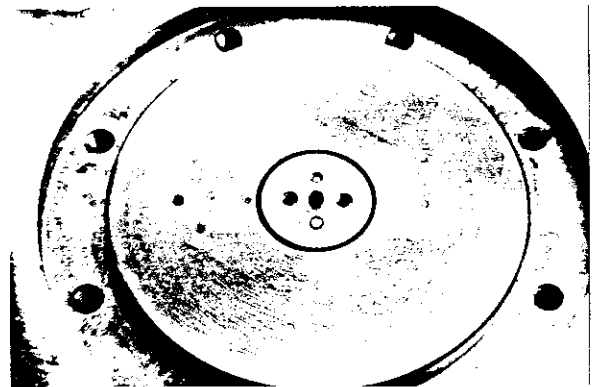

(d) Close View of Control Sensing Disc. (Note: Do not lose plexiglass cylinder which may stick to membrane).

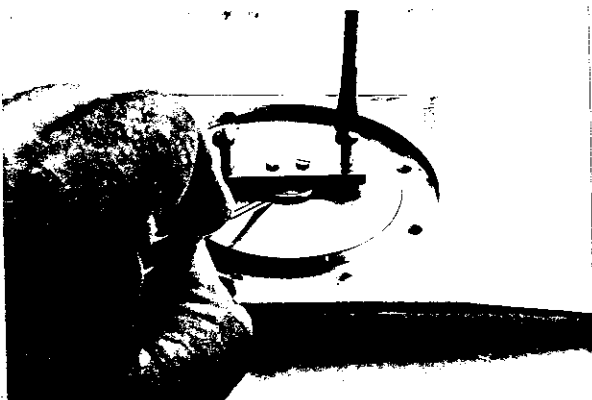

(e) Remove Control Sensing Disc Using Special Puller.

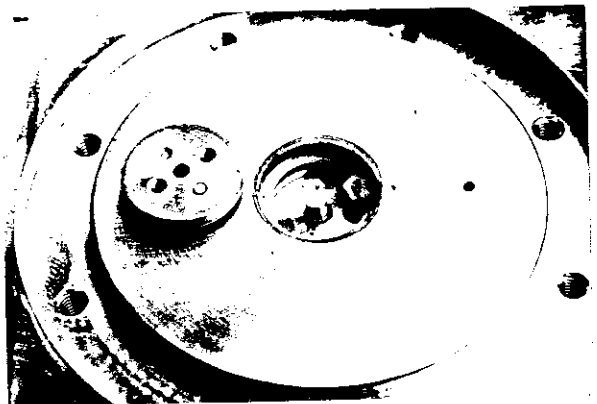

(f) View Inside Dilatometer Below Central Sensing Disc (Note: remove stainless steel cylinder and spring).

FIGURE 13 CLEANING DILATOMETER

4. Remove steel cylinder and spring: Remove the steel cylinder and spring inside the center hole using tweezers. (Fig. 13f).
5. Clean: Scrape inside the center hole using the needle probe (Fig. 13g). Clean the hole using a tissue and the small screwdriver (Fig. 13h). Scrub both bases of steel cylinder and spring using sand paper. Remove dust with a tissue. Scrub with hand brush on both sides of the sensing disc. Use tissues and q-tips to carefully clean all the exposed parts.
6. Checks: Make certain that the connector wire does not touch any part of the dilatometer but rather lies entirely on the inside of the insulating seat (Fig. 13i). Brush the end of the wires to make sure that they fall out now during the cleaning operations if any are almost broken. Tap with the plastic hammer on the backside of the dilatometer while holding the sensing side down so that any particles that are loose will fall out. Make certain that the "half moon-shaped" spring underneath the sensing disc actually spring-loads the feeler (Fig. j and k). If the "half moon-shaped" spring has been damaged, remove the small screw retaining it and flatten the spring with the plastic hammer. Then the spring may be reused.
7. Replace conductor inside the dilatometer: If there are reasons to believe that the conductor inside the dilatometer (Fig. 13(l)) is worn, it should be replaced. This can be done by removing the pvc cylinder inside the threaded stem of the dilatometer with the special tool, thereby removing the wire. Replace the wire, thread it through the dilatometer and the hole in the insulating seat. Remove approximately 3.5 mm of insulation and divide the wires into 2 sections spreading them on the inside of the insulating seat. Then press the wires with a small flat ended dowel of approximately 2 mm diameter thereby pushing the wiring flat into place.

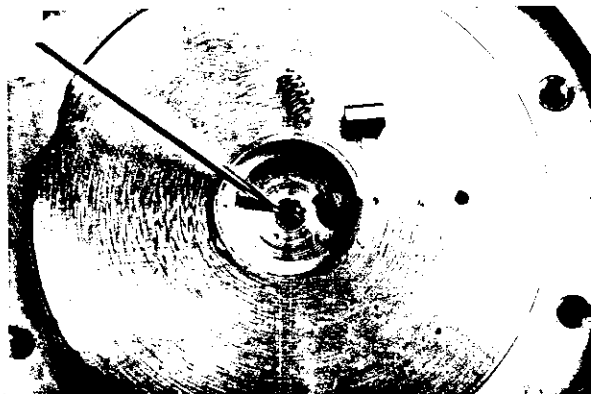

(g) Scratch Sides and Bottom of Hole in Center of Dilatometer With Needle Probe to Insure Good Electrical Contact.

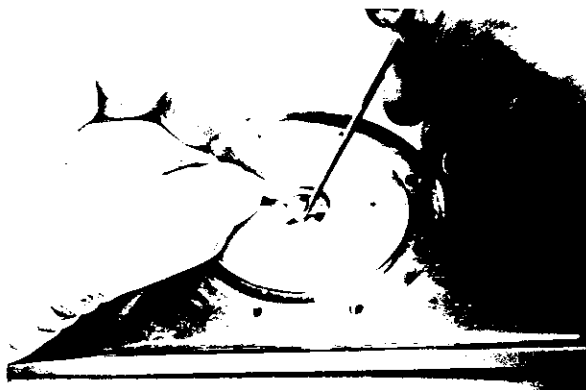

(h) Clean Central Hole With Tissue.

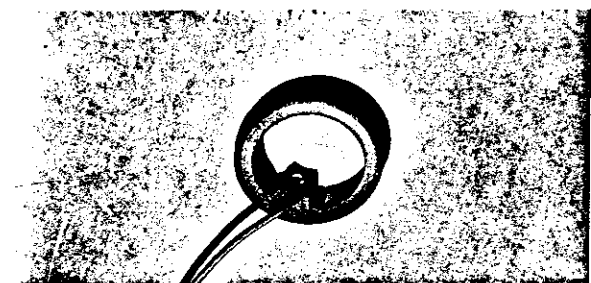

(i) Insulating Seat and Electrical Wire That Makes Contact With Central Sensing Disc.



(j) Check to Make Sure "Feeler" is Spring Loaded.

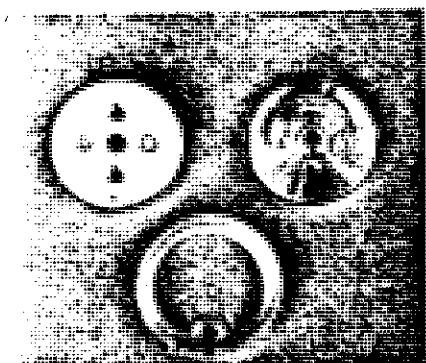

(k) Top View (top left) of Central Sensing Disc, Bottom View (top right) and Insulating Seat (bottom).

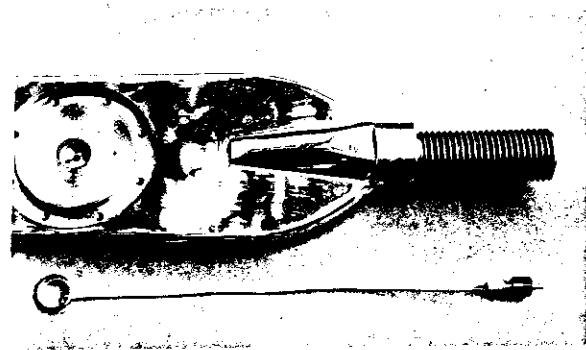

(l) Electrical Wire (bottom) That Leads Between the Central Sensing Disc and the Dilatometer Throat.

8. Reassemble: Reinsert the inner spring and the steel cylinder in the central hole. Insert the sensing disc insuring that the punch marks on the dilatometer and cylinder line up (at least approximately). Drive the sensing disc with the plastic hammer flush with the dilatometer (Fig. 13m). Note that the insulating seat and the sensing disc are matched for a particular dilatometer and, in general, should not be interchanged.

9. Check elevations of sensing disc and feeler: The nominal values of the elevations of the sensing disc and feeler above the surrounding plane are 0.05 mm and 0.10 mm respectively (Fig. 13n). However dimensions within the following ranges are acceptable:

The sensing disc must protrude from the surrounding plane
1 to 7 mm/100 (preferably 3 to 5)

The feeler must protrude from the plate 6 ± 2 mm/100

To measure the elevations and make sure then are within tolerance use the special tool (Fig. 13o). If the sensing disc is too high, remove extraneous material (chips of insulating seat, soil particles, etc.) possibly trapped beneath or above the insulating seat. If the sensing disc is too low insert layers of teflon beneath the insulating seat (Fig. 13p). Then trim the excess teflon. The feeler elevation is normally either correct or low. If it is low, remove the sensing disc, turn it over and remove dirt between the flat end of the feeler and the sensing disc. When the elevations are within tolerance, proceed to the next step.

10. Reassembling the membrane and ring: Make sure the plexiglass cylinder is in place. Put gasket, membrane and ring in their place. Insert the screws in the holes of the ring, snug them down, then alternatively tighten them as tight as practical (by hand) with the larger screwdriver supplied.

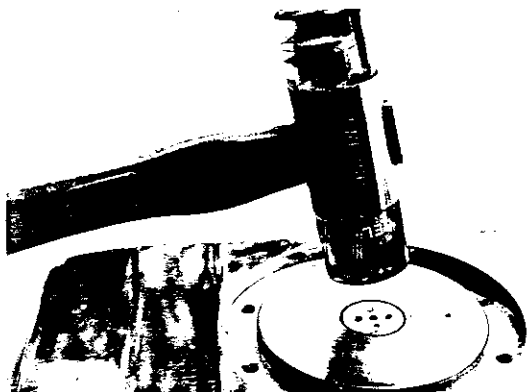

(m) Replace Spring and Stainless Steel Cylinder and Then Place Central Sensing Disc and Drive Into Position With Plastic Hammer. (Make sure "punch marks" are aligned).

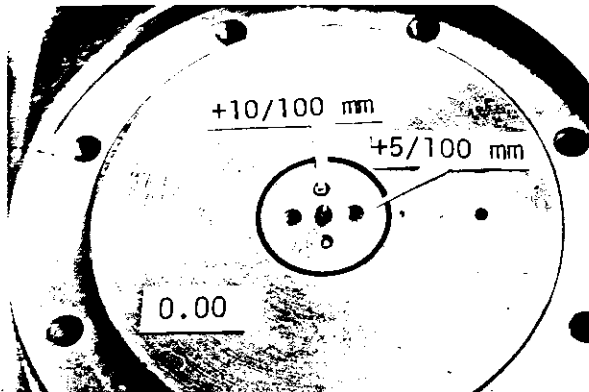

(n) Ideal Relative Elevations.

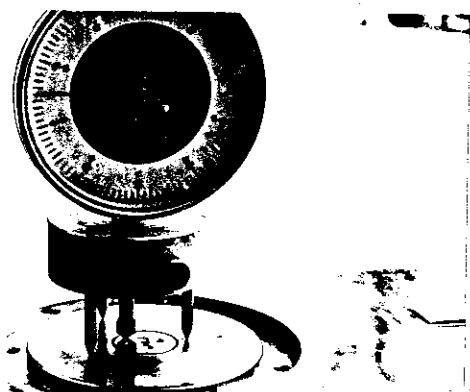

(o) Check Tolerances with Tripod and Dial Gauge.



(p) If Central Sensing Disc is Too Low Raise Using Teflon "Shims". (Trim excess insulating seat with razor blade.

11. Check air tightness: Immerse the tip in a bucket of water and pressurize the tip slightly (no more than 3 bar). If there are leaks, bubbles will appear. However leaks are usually easily recognized even without water. To do this, pressurize the tip as above (no more than 3 bar) using the control box. Then close the micrometer valve. If the pressure gauge does not decrease in one minute, there are usually no leaks.

12. Exercise the membrane: If the membrane is new (or $\Delta B > 0.7$ bar) then the membrane must be exercised in order to reduce ΔB to the required 0.4 ± 0.3 bar. The procedure follows:
 - (a) Set up the equipment in the same arrangement as it is when performing a test (Fig. 8), except that the dilatometer is now in free air.
 - (b) Slowly pressurize the membrane. Note on the gauge of the control box the pressure at which the galvanometer and the buzzer are activated. This pressure, which is the initial value of ΔB , is generally not higher than 3 bar. (If at 3 bar still no signal is emitted, check if the connections are correct. If the connections are correct, pressing on the center of the membrane should activate the signals). If the recorded ΔB is within tolerance, there is no need to exercise, in which case proceed to Step 13.

 - (c) Exercise the membrane several times, with a maximum pressure in the cycle of 3 bar. Each time the pressure is increased starting from zero, the new value of ΔB should be noted. If ΔB falls to a value within tolerance then no further exercising is needed, in which case proceed to Step. 13.

 - (d) If ΔB is still too high, exercise the membrane raising the maximum pressure in the cycle to 3.5 bar, and exercise several times noting the ΔB value each time as before.

Repeat the exercise adding 0.5 bar to the maximum pressure in the cycle, until ΔB decreases to a value less than 0.7 bar or, better still, to approximately 0.4 bar. Maximum pressures less than 6 bar are normally sufficient to reduce ΔB as required. Pressures beyond 6 bar may be dangerous (may blow out the membrane and should not be used.

(e) When ΔB has dropped to an acceptable value according to the gauge of the control unit, proceed to Step 13.

13. Determine membrane corrections ΔA and ΔB : Follow the procedure described in section 2.2, requiring the use of the calibration device.
14. Mark $\Delta A, \Delta B$ on sticker on Dilatometer: The membrane corrections marked on the sticker will be useful to the next user of the tip. Also the presence of the sticker means that that tip has not been used after servicing and therefore is ready to be sent to the field.

Notes

- a. Sometimes during the exercising procedure the membrane may be mistakenly overinflated. Overinflation is recognized because ΔB measured with the calibration unit is very small or in some extreme cases a vacuum may be required to activate the signal. In such event it is sometimes possible to salvage the membrane by carefully hammering on the membrane periphery (just inside the retaining ring) with the plastic hammer. After this operation check ΔA and ΔB again to make sure they are within acceptable limits.
- b. Pressures as high as 3 bar cannot be produced with the syringe provided with the membrane equipment. Therefore the pressure bottle is required for the exercise operation. However an optional pneumatic piston may be obtained from the manufacturer which allows exercise of the membrane without the use of a pressure bottle.

3.2 Service of Dilatometer Tips Upon Return from Field

1. No problems reported: If (a) no problems with the dilatometer are reported (b) the membrane is in good shape, (c) the membrane corrections are within tolerance, there is no need for dismantling. In such a case just perform Steps 13 and 14 of the maintenance procedure described in section 3.1.

2. Membrane must be replaced but interior of the dilatometer is clean:
If the membrane needs to be replaced but no water or mud has entered inside the dilatometer, follow the membrane replacement procedure described in section 2.2.

3. Dilatometer interior needs cleaning: Follow the entire maintenance procedure described in section 3.1.

Notes:

- a. From time to time the tips should be checked to make sure they are straight. To perform this check the adapter is screwed to the dilatometer and a square is placed against the side of the adapter. The distance from the blade to the side of the square over the tip is marked. The tip is then rotated 180° and the difference checked again. The measurements should agree within 4 mm (when the tips are new they agree within 2 mm). If the bend is not serious, the tip may be straightened using a hydraulic press or a lever.

- b. If the tip of the dilatometer is bent, due to some obstruction, the edge should be sharpened using a file. However, before filing, straighten major undulations.

3.3 Service of Control Unit Upon Return From Field

If no problems with the control unit are reported, there is no strict need of checking the unit for proper working conditions. However, as a precaution, the following routine checks are recommended:

1. Using an electrical continuity tester (a battery in series with a light may do the job), check that the female quick connector marked "Dilatometer" is insulated from the metal front panel.
2. Using an electrical continuity tester check that the inside of the ground jack is insulated from the metal front panel.
3. Press the push button on the control box, with the audio switch in the ON position. The galvanometer and the buzzer should be activated.
4. Using a wire, connect the inside of the ground jack with the female quick connector marked "Dilatometer". The galvanometer and the buzzer should be activated.
5. If a gas leakage is suspected pressurize the control unit to check for air tightness. This check is described in section 3.5 (Troubleshooting Guide).

3.4 Service of Pneumatic-Electric Cables Upon Return from the Field

1. Mechanical checks: Inspect to determine if the tubing has been pinched or broken. Pinched cables may be used if they pass the checks 2, 3, 4 below.
2. Electrical checks: Check either the electrical continuity or the electrical insulation between the terminals as appropriate. The male quick connectors should be in contact with the inner wire while the stainless steel terminals should be insulated from the wire. Use an electrical continuity tester to perform the checks (Fig. 14a and b).
3. Pneumatic check: Block the male stainless steel terminal of the cable with the closed terminal provided. Use the control unit to pressurize the cable to the capacity of the unit (normally 40 bar). Place the cable and the fittings underwater to check for air leaks.
4. Check for obstructions: (This check must be performed on repaired or pinched cables): Use the control unit pressurized with a 40 bar source. Insert the male quick connector of the cable into the corresponding female quick connector of the control unit. The other end of the cable is left open. Open the Micrometer valve completely. The pressure build-up, read at the gauge, should not be more than 10 bar for a 30 m cable, 8 bar for a 30 m cable, 1 or 2 bar for the short connector cable (10 to 20 cm long).

If the above checks are not satisfactory, the cable should be returned to the service representative for repairing, which requires a relatively complex procedure. Some details of the terminals are shown in Fig. 14c. If in an emergency situation a cable repair has been attempted, the above 4 checks should be performed.

If a cable has satisfactorily passed the checks, place a small strip of "label" paper across terminal and cap (Fig. 14d). The presence of the strip means that the cable has not been used since servicing and is ready to be sent to the field.

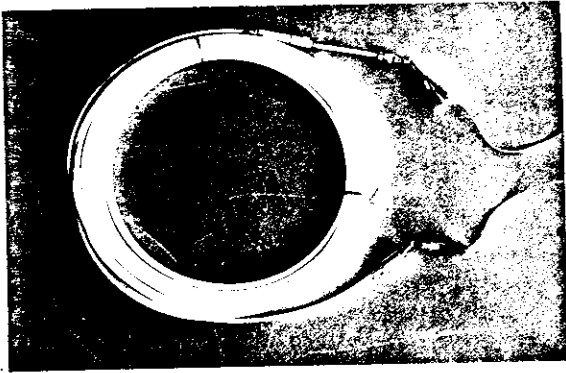

(a) Check for Proper Electrical Continuity (current should flow through cable when hooked as shown).

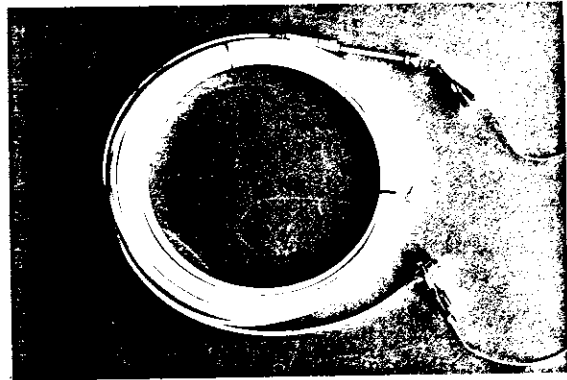

(b) Check for Proper Electrical Insulation (current should not flow through cable when hooked as shown).

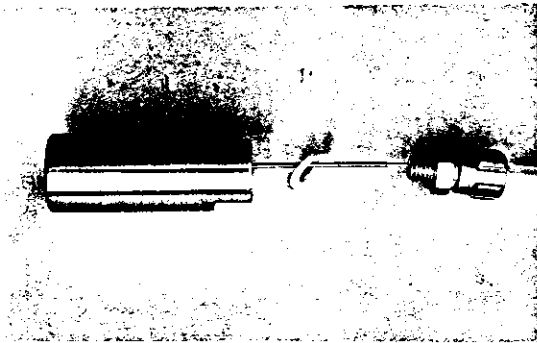

(c) Expanded View of Female Stainless Steel Connector. (Note teflon cover insulating electrical wire).

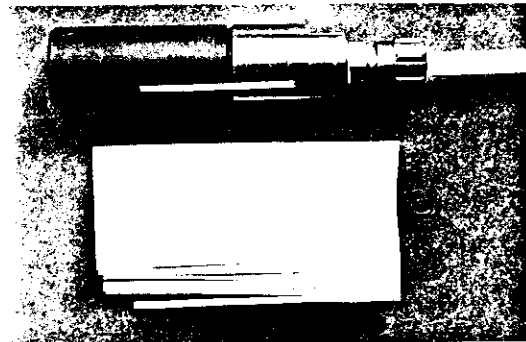

(d) Place Small Strip of "Label" Paper Across Terminal and Cap After Cable Has Passed Checks.

FIGURE 14 CHECKS ON PNEUMATIC-ELECTRIC CABLES UPON RETURN FROM THE FIELD

3.5 Troubleshooting Guide

In case of malfunction, the operator should first determine if the malfunction originates from the (a) dilatometer, (b) cables, or (c) control unit. This identification is generally performed easily by successive replacements of the dilatometer and of the cable. The operator should always bring to the field more than one tip and several cables, both for the reason just mentioned and to allow test continuation with the back up component in case of malfunction. The control unit is not likely to present problems.

The following guide gives a list of potential problems, probable causes and corrective actions suggested.

3.5.1 Dilatometer

a. Short circuit (a continuous signal is emitted). Possible causes are:

- (1) insulation of internal conductor (Fig. 13 l) damaged
- (2) some wires left beneath plastic insulator as in Fig. 13i
- (3) metal particles between sensing disc and underlying body of the dilatometer
- (4) the plexiglass cylinder is missing
- (5) water is inside the dilatometer. However in this case the signal is generally low and fluctuating

Identify the cause and correct as appropriate.

b. Absence of signal (no signal is emitted). Possible causes are:

- (1) internal conductor (Fig. 13 l) is broken
- (2) the spread wires beneath sensing disc (Fig. 13g) are missing
- (3) the bottom of the center hole and/or the bases of the steel cylinder and spring and/or the rear of the sensing disc are dirty

Identify the cause and correct as appropriate.

c. Reading B not signaled (second reading only not obtained) Possible causes are:

- (1) plexiglass cylinder is not sliding freely in the center hole of the sensing disc
- (2) the bottom cylinder is not sliding freely in the center hole of the dilatometer body.
- (3) the steel cylinder and/or the spring are missing

Identify the cause and correct as appropriate.

d. Excessive correction ΔA : $\Delta A > 0.2$ is irregular. Possible causes are:

- (1) the rim of the insulating seat is too high and protrudes above the surrounding plane. If so, after hammering down the sensing disc, trim flush with a razor blade.
- (2) the half-moon shaped spring on the rear of the sensing disc is damaged (see section 3.1.6) so that the feeler is not effectively spring supported.
- (3) the elevation of the sensing disc is too low. Check it as described in section 3.1.9. If the elevation is not within tolerance, correct as described in 3.1.9.
- (4) Dirt is interposed between the flat end of the feeler and the rear of the sensing disc.

Identify the cause and correct as appropriate.

3.5.2 Cables

- a. Circuit interrupted: If the cable does not carry the electrical signal the internal wire may be broken. Check its integrity especially in the vicinity of the terminals. Replace the cable.
- b. Short Circuit: If a cable produces an electrical short circuit the wire must make contact with the stainless steel terminals. Replace the cable. The short circuit may also be due to water in the cable. If so, dry by blowing air through the cable.
- c. Leakage: If the cable is not air tight this is usually due to a breakage in the nylon tubing. If so replace the cable. Also lack of air tightness may be due to wearing (or absence) of the nylon washer between the stainless steel terminals. If so, replace nylon washer.

3.5.3 Control Unit

- a. venting too slow: if venting (from whatever pressure indicated by the gauge) requires more than 2 to 3 sec (with a \sim 30 m cable), there is probably some obstruction in the Vent valve or in the line leading to it. Remove obstruction. If necessary, replace Vent valve.
- b. gauge increases by jerks: If, in the pressurizing stage, the pressure increases by "jerks", rather than at a smooth rate, there is probably some obstruction in the internal needle valve. Disconnect the line exiting from this valve, unscrew the needle in order to open the valve as much as possible, then let some gas flow through it, observing if metal or dirt particles exit. Alternatively replace this needle valve.
- c. air tightness: If a leak is suspected, pressurize the unit (without any cable inserted in the female quick connector marked "Dilatometer") to a pressure between 30 and 40 bar (standard unit). Then close the General valve. If the gauge does not decrease more than 5 bar in 5 min the air tightness is satisfactory. Otherwise try to locate the leak and repair it. If a complete repair is needed, ship to service representative. Also check for the presence of the O-rings in the female connectors.

3.5.4 System

- a. Absence of signal: Possible causes are:
 - (1) insufficient horizontal pressure exerted by the soil
(At larger depths the problem should disappear).
 - (2) ground cable improperly connected
 - (3) battery inside the control unit disconnected or exhausted or broken wire.
- b. Lack of air tightness: Air tightness is easily checked during testing by closing the Micrometer valve and observing if the pressure gauge remains constant. In case of leakage identify the responsible component and see preceding sections. If the dilatometer is advanced by driving, see Remark 2.1.3e.

CHAPTER 4. REDUCTION AND INTERPRETATION

4.1 Check of Data Before Reduction

Before reducing the data, the operator must perform a preliminary check to insure compatibility between the selected calibration constants and the A and B readings. He must check that, for each pair of A, B, the following condition is satisfied.

$$B-A \geq (\Delta A + \Delta B) \quad (4.1)$$

This condition derives from the fact that in free air (or in a fluid) $B-A = (\Delta A + \Delta B)$. Therefore even in nearly fluid soils the difference $B-A$, reflecting stiffness, should be at least $(\Delta A + \Delta B)$. (The above condition for $B-A$ is equivalent to the condition $E_D \geq 0$, which is satisfied when Eq. 4.1 is satisfied, see Eqs. 4.3a and 4.6). If, as recommended earlier, ΔA and ΔB have been chosen as the average between the carefully measured values before and after each sounding, Eq. 4.1 is usually satisfied and the operator, after making sure of it, can proceed to the data reduction.

If at some depth Eq. 4.1 is not satisfied, the operator must decrease ΔA and/or ΔB in order to reduce the sum $\Delta A + \Delta B$ and satisfy Eq. 4.1. Since this check results in a condition for the sum $\Delta A + \Delta B$ and not for the individual values of ΔA and ΔB , the operator must still decide if the reduction of the sum $\Delta A + \Delta B$ is to be accomplished by reduction of ΔA or ΔB or both. The following indications may be of help in such a decision.

The value of ΔA has been observed, in the great majority of the cases, to be between .10 and .12 bar. Therefore if the average measured $\Delta A > .12$ and if a reduction in $\Delta A + \Delta B$ is needed, it is suggested that, to start with, ΔA be reduced to .12 - .10. Then, if necessary, reduce ΔB .

Consider the following example in which a nearly fluid clay is found beneath a hard crust. Suppose that $\Delta B_{\text{before}} = .60$ and $\Delta B_{\text{after}} = .30$. The arithmetic average ΔB would be .45. However, considering that (a) most of the ΔB decrease probably occurred in the hard crust so that ΔB_{after} was probably effective when testing the soft clay (b) it is much more important to have the calibration constants correct in the soft clay than in the hard crust, a more suitable value for ΔB might be about .35 (a "logical" average may be more appropriate than the "arithmetic" average).

4.2 Data Reduction

This Section gives the equations to determine the corrected readings p_0 and p_1 and intermediate parameters I_D , K_D , E_D used later in the correlation equations for soil parameters. These equations follow:

$$p_0 = 1.05 (A - Z_M + \Delta A) - 0.05 (B - Z_M - \Delta B) \dots \dots \dots (4.2)$$

$$p_1 = B - Z_M - \Delta B \dots \dots \dots (4.3)$$

$$\Delta p = p_1 - p_0 = 1.05 [B - A - (\Delta A + \Delta B)] \dots \dots \dots (4.3a)$$

$$I_D = (p_1 - p_0) / (p_0 - u_0) \dots \dots \dots (4.4)$$

$$K_D = (p_0 - u_0) / \bar{\sigma}_v \dots \dots \dots (4.5)$$

$$E_D = 34.7 (p_1 - p_0) \dots \dots \dots (4.6)$$

where:

p_0 = corrected first reading

p_1 = corrected second reading

I_D = Material Index

K_D = Horizontal Stress Index

E_D = Dilatometer modulus

u_0 = pore water pressure prior to dilatometer insertion

$\bar{\sigma}_v$ = vertical effective stress prior to dilatometer insertion

A = first dilatometer reading

B = second dilatometer reading

ΔA = free air correction to A

ΔB = free air correction to B

Z_M = control unit reading when system is vented

Note that $\bar{\sigma}_v$ and u_0 are the values prior to insertion of the dilatometer and have to be known at least approximately. The ground water table (or pore water pressure distribution if not hydrostatic) should be determined and recorded while in the field. A rough estimate of the soil unit weight (γ) necessary for calculating $\bar{\sigma}_v$ may be obtained from the chart of Fig 15 if more accurate data is not available.

FIG. 15 CHART FOR SOIL DESCRIPTION AND γ EVALUATION $[\gamma] = t/m^3$

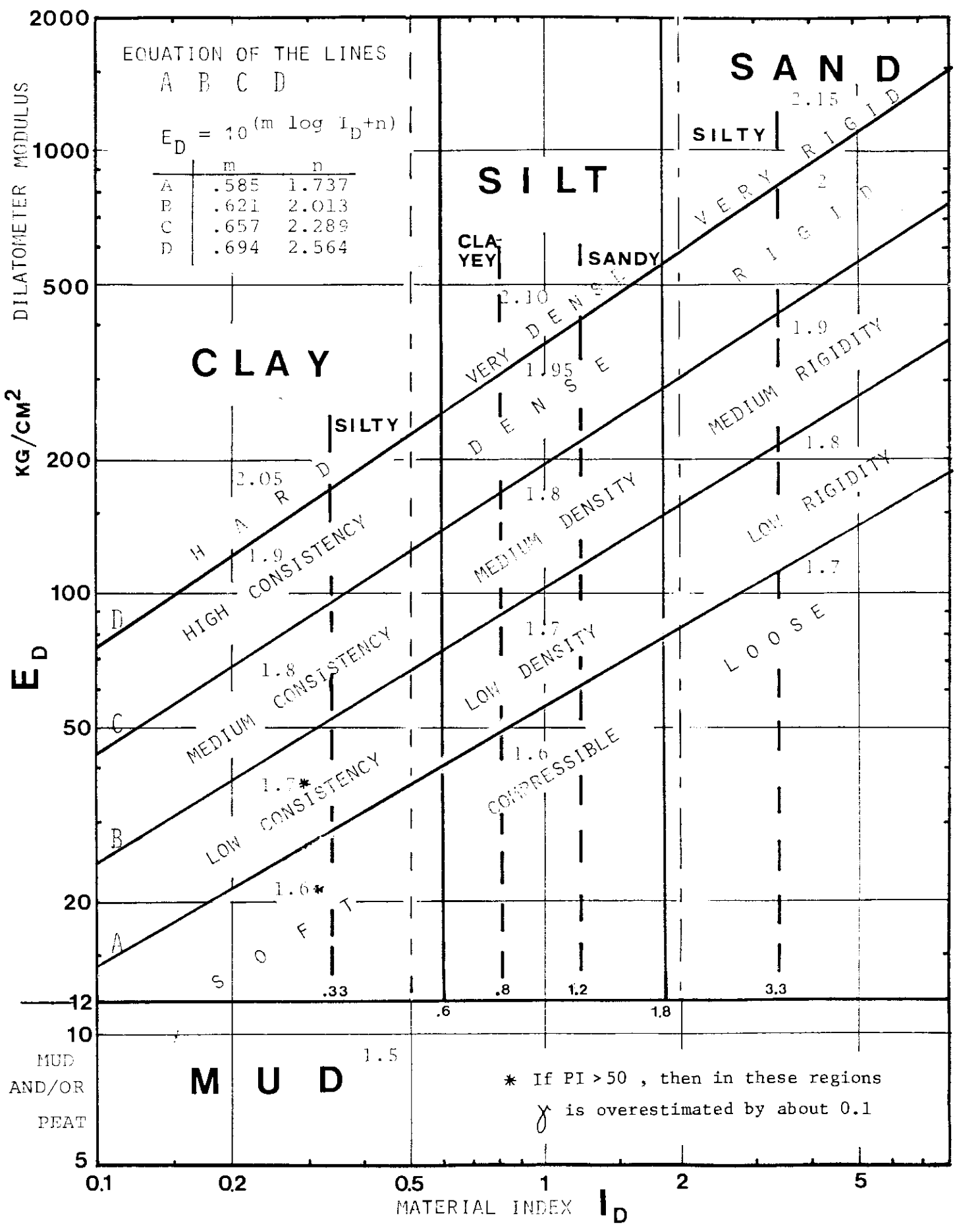

4.3 Correlations for Soil Parameters

4.3.1 OCR - Overconsolidation ratio

If $I_D < 1.2$ $OCR = (0.5 K_D)^{1.56}$ (4.7)

If $I_D > 2$ $OCR = (0.67 K_D)^{1.91}$ (4.8)

If $1.2 < I_D < 2$ $OCR = (mK_D)^n$ (4.9)

Where: $p = (I_D - 1.2)/0.8$ (4.9a)

$m = 0.5 + 0.17p$ (4.9b)

$n = 1.56 + 0.35 p$ (4.9c)

If OCR values are less than 0.8 the results should be reported as $OCR < 0.8$, because outside the range of the correlations.

4.3.2 K_o - Coefficient of earth pressure insitu

$K_o = (K_D/1.5)^{0.47} - 0.6$ (4.10)

If $K_o < 0.3$ values result from the above calculation, report as $K_o < 0.3$ for the reason previously explained in 4.3.1.

4.3.3 M - Vertical drained constrained modulus

$M = R_M E_D$ (4.11)

Where: If $I_D \leq 0.6$ $R_M = 0.14 + 2.36 \log K_D$ (4.11a)

If $I_D \geq 3$ $R_M = 0.5 + 2 \log K_D$ (4.11b)

If $0.6 < I_D < 3$ $R_M = R_{M,0} + (2.5 - R_{M,0}) \log K_D$ (4.11c)

with $R_{M,0} = 0.14 + 0.36 \frac{I_D - 0.6}{2.4}$ (4.11d)

If Eqs. 10 provide a value for $R_M < 0.85$, then use $R_M = 0.85$.

4.3.4 c_u - Undrained Shear Strength (calculate only if $I_D \leq 1.2$)

$$c_u = 0.22 \bar{\sigma}_v (0.5 K_D)^{1.25} \dots \dots \dots (4.12)$$

If $I_D > 1.2$, the soil is cohesionless and the value should not be calculated.

4.3.5 ϕ' - friction angle, drained (calculate only if $I_D > 1.2$)

$$\phi' = 25 + 0.19 \cdot \sqrt{P-100} \dots \dots \dots (4.13)$$

where: $P = I_D R_c \dots \dots \dots (4.13a)$

If $\bar{\sigma}_v < 0.5$ bar and $R > 500$ then

$$R_c = 500 + \frac{R-500}{1 + \frac{R-500}{1500}} \dots \dots \dots (4.13b)$$

If $R \leq 500$ or $\bar{\sigma}_v \geq 0.5$ bar

then $R_c = R \dots \dots \dots (4.13c)$

where: $R = \frac{E_D}{\bar{\sigma}_v} \dots \dots \dots (4.13d)$

Note: these correlations are based on very few data points and therefore are preliminary in nature.

4.3.6 p_c - Preconsolidation stress

$$p_c = OCR \bar{\sigma}_v \dots \dots \dots (4.14)$$

If $p_c < \bar{\sigma}_v$ report as $p_c < \bar{\sigma}_v \dots \dots \dots$

4.3.7 q = Difference between preconsolidation stress and present overburden stress (eroded overburden above present ground surface)

$$q = \bar{\sigma}_v (OCR-1) \dots \dots \dots (4.15)$$

If $q < 0$ report as $q < 0$

4.4 Tips for the Reduction of Data by Computer

The operations necessary to reduce the data, though relatively simple, are rather numerous. Therefore a computer can greatly reduce the computation time. Depending on the capacity of the computer available, the operator can assign various tasks to it.

a. Pocket calculator (preferably programmable).

The data are reduced as in the hand computation procedure. The Table containing the results is filled in by hand and the diagrams are also plotted by hand.

Programmable calculators offer the considerable advantage of not requiring writing down and reentering intermediate results. The Table is then greatly simplified because it can contain only the input data and the data to be plotted (I_D , M , C_u , ϕ and possibly K_D , OCR , K_o). The automatic selection of the soil description based on the chart is often not possible with these calculators. However the plot of I_D vs. depth (see sample presentation) is even more effective in providing the same information. Even when a large computer is available in the office, the availability of a pocket calculator based reduction procedure is useful, e.g. for rapid data reduction on the site.

A computer program in this category is the program "D" written by John Schmertmann for the Hewlett Packard pocket calculator 41C. This program uses approximately 500 programmable steps and 40 storage registers. The user first inputs a set of general preliminary data ($\Delta A, \Delta B, Z_M, Z_{initial}, Z_{water}, \bar{\sigma}_v initial$). Then at each depth the user enters A, B and gets all the computed parameters.

b. Medium capacity computer (say 32K): the computer can perform calculations and store in memory all the data and the interpreted parameters relative to one sounding. If a printer is available, the tabular output is printed automatically. The diagrams must then be plotted manually.

A computer program in this category is the program "DILLY", written by David Crapps and Gary Schmertmann, in Fortran, also

providing approximate plots using the printer. Documentation of this program is presented in a separate report.

- c. Same computer as in b but with a plotter. the additional advantage is that the diagrams are plotted automatically.

A series of computer programs in Basic (interactive) for a Hewlett Packard system including a plotter, providing results in the form of the ones displayed in the Closure to the ASCE paper (June , 1981, GED), has been written by Silvano Marchetti and is documented in a separate report.

A very desirable feature, for whichever computer is used, is the possibility of recording the data for each sounding on a storage medium (for example on a cassette or magnetic card).

More details and recommendations for writing computer programs for the dilatometer are given in the Appendix 6.5. Reports including computer program listings are referenced to in the Bibliography.

4.5 Comments on Data Interpretation

Since DMT results are expressed in terms of conventional soil parameters, once the engineer has the DMT results available, he will use them in conjunction with the same methods he normally uses and in which such soil parameters are the necessary input.

Some comments on the practical use in design of DMT estimates of soil parameters are given in the conclusions of Marchetti's ASCE paper and in the Closure to the same paper. Some of the most relevant to design are listed below:

4.5.1. I_D is an index remarkably constant in an homogeneous formation. It reflects very sensitively changes in formation. Its normal range extends over two log cycles, from 0.1 to 10. I_D seems related to the Rigidity Index I_R (or reduced rigidity index I_{RR}) introduced by Vesic (Vesic A.S. 1972 "Expansion of Cavities in Infinite Soil Mass", ISMFD, ASCE, Vol. 98, No. SM3, See p. 268) as an index of the stiffness/strength ratio. This is apparent in the case of soft to medium clays where $p_o - u_o$ (in the denominator of I_D) is generally 8 to 10 times c_u (*) and Δp (in the numerator of I_D) is proportional to stiffness.

4.5.2. Estimates of c_u are generally somewhat conservative and in principle can be used unmodified in design, with the exception of sensitive clays. In sensitive clays the only available data (Onsøy site) indicate close agreement (within a few %) of $(c_u)_{DMT}$ with $(c_u)_{FIELD VANE}$. Since in sensitive clays FIELD VANE may overestimate $(c_u)_{DESIGN}$, DMT may overestimate $(c_u)_{DESIGN}$ in those clays as well.

*An equivalent way of writing the Equation for c_u/σ_v in Fig. 13 of the ASCE paper is

$$c_u = \frac{p_o - u_o}{10.8} \cdot \left(\frac{p_o - u_o}{\sigma_v} \right)^{0.25}$$

The second term varies little in NC or moderately OC clays, where its value is usually in the range 1.1 to 1.4. Thus, in those clays, the equation above becomes

$$c_u = \frac{p_o - u_o}{8 \text{ to } 10}$$

4.5.3 K_D (from which OCR is inferred) is a parameter which increases as the summation of the effects of the following phenomena increases:

- a. Horizontal stress higher than the $K_{O,NC}$ value.
- b. Cementation and aging
- c. Cycles of prestressing (*)
- d. Vibrations (sand)
- e. Stiffer structure/packing, interlocking (for a given void ratio or D_r , sand)
- f. Density (or relative density D_r , sand)
- g. Natural one dimensional overconsolidation caused by an eroded overburden (however g. can be regarded as a combination of a. and c.)

In those NC clays in which none of the above phenomena has taken place, K_D is typically 2. This is in fact the typical minimum value of K_D found in natural deposits of NC clay. In NC sands deposited underwater (with estimated $D_r \approx 60-70\%$) the value $K_D \approx 1.5$ (constant with depth) has commonly been observed (Torre Oglio, Damman and many others). Hence $K_D = 1.5$ seems a typical value for NC sands deposited underwater with $D_r \approx 60-70\%$. However in very loose sand deposits ($D_r = 20\%$) values of K_D as low as 0.7 (Jacksonville, FL) have been observed (0.7 is the minimum value of K_D so far found in sand, after testing in scores of sand sites).

Thus when $K_D < 1.5-1.6$, then D_r is likely to be less than 60-70% and liquefaction is likely to be a ^{problem.} Note that when $K_D = 2$ in clay (or $K_D = 1.5$ in sand), the OCR inferred via Fig. 11b of the ASCE paper is unity. Thus $OCR < 1$ ^{in clay denotes underconsolidation, $OCR < 1$} in sand means tendency to liquefaction. When $K_D > 2$ in clay (or $K_D > 1.5$ in sand) one or more of the phenomena above must have taken place (and the inferred $OCR > 1$). But in general the knowledge of K_D alone does not permit one to separately evaluate the intensity with which each phenomenon has acted (see however p. 316 of the ASCE paper). Since the dilatometer correlations for K_D and OCR were derived in mechanically overconsolidated uncemented natural deposits, if in addition to OCR some other of the phenomena above has contributed to increase K_D , then OCR and K_O (inferred from K_D through these correlations) will be overestimated. In such cases OCR estimated by the dilatometer must be regarded as an "equivalent" overconsolidation ratio reflecting the combined effect of the phenomena listed above. If the inferred OCR is 1, none of the above phenomena has taken place. If it is > 1 , one or more of the phenomena above have occurred.

*Recent research with the University of Florida calibration chamber has shown that a pure K_O prestressing cycle (pure prestressing = overconsolidation without additional horizontal stresses left applied to the sample) on a K_O N.C. sand sample to $OCR = 2$ was reflected by an increase in K_D by a factor of about 2.

Note that all of the phenomena listed above are "beneficial" from the standpoint of many practical problems (settlement analysis, sand liquefaction, etc). For such problems a high K_D (or an inferred $OCR > 1$) is "welcome" regardless of its cause. Conversely the engineer must be concerned when K_D assumes its minimum values (or inferred $OCR \leq 1$), because then none of the above "overconsolidating agents" has improved his foundation soil.

- 4.5.4. M is the tangent incremental one dimensional modulus ($1/m_v$) correspondent to the vertical effective stress (in situ $\bar{\sigma}_v$)

$$M = \left(\frac{\Delta \sigma}{\Delta \epsilon_v} \right) \epsilon_h = 0 \quad \text{at } \bar{\sigma}_v$$

In general M can be used with satisfactory approximation even for stress increments not infinitesimal, such as the ones usually of interest to the engineer. However in lightly OC clays the engineer should always check if the final vertical effective stress which will be reached in the soil, after the foundation load has been applied, exceeds the maximum past pressure p_c . If this is the case, the DMT estimates of M are no longer applicable. In fact once p_c is exceeded the stiffness drops substantially and considerably reduced M values should be used. (DMT provides no estimates of such reduced moduli). A short summary of methods in use for settlement analysis based on M is given in Section 5.1.

4.6 Reliability and usability of parameters from DMT (June 1981)

4.6.1 Satisfactory

- M (constrained tangent modulus): max. deviation from straight line through data points less than 35%, in both cohesive and cohesionless soils. However in lightly OC clays if p_c is exceeded, M drops after p_c - DMT provides no estimate for such reduced moduli.
- Cu Clays of moderate sensitivity OK. $(Cu)_{DMT}$ compares well (usually is slightly less) with $(Cu)_{FIELD\ VANE}$ already reduced for Bjerrum correction. Hence $(Cu)_{DMT}$ has been used many times in design-unmodified. In sensitive clays (say $St > 5$) sufficient information is not available yet.
- I_D Material index: I_D has proven to be a very useful and sensitive index. I_D is remarkable constant in a uniform formation. It reflects very sensitively changes in formation. It extends over two log cycles (from 0.1 to 10). However the consequences of description being inferred from mechanical behavior must be appreciated and understood: e.g. a mixture of clay and sand will probably be described as silt.

4.6.2 Satisfactory Under Conditions

- OCR clays: The predictions are satisfactory only in uncemented clays in simple unloading. Otherwise OCR is almost always overpredicted.
- K_o clays: The predictions are satisfactory only in uncemented clays.

4.6.3 Unsatisfactory

- OCR in sand (usually overpredicted)
- K_o in sand

4.6.4 Under Study

- ϕ' in sand: see preliminary note by Schmertmann, based on Mitchell theory for wedge capacity. Note: requires knowledge of sand resistance against tip.
- Low D_r Sand liquefaction: when K_D (in sand) is less than 1.5-1.6, D_r is typically less than 60 - 70% (= potential liquefaction problems). Investigation: can the range $D_r = 20 - 70\%$ (common range of potential liquefaction problems) be associated to a corresponding range of K_D (e.g. 0.70 to 1.60)?

4.6.5 Reproducibility of Results

very good. See Fig. 17 in the Closure to the ASCE paper GED June 1981).

4.7 Presentation of Results

Results are displayed both in tabular form (one Table) and in a graphical form (one graph sheet). Sometimes an optional second graph sheet, when appropriate, is produced. These recommendations apply both to hand and computer calculations.

4.7.1 Table - The Table in Fig. 21 shows the recommended way of displaying in a tabular form all parameters of interest. The last column contains a soil description based on the chart previously described.

4.7.2 Graphs - In general one graph sheet is sufficient to display the most interesting soil parameters (I_D , M , C_u , ϕ). Sometimes a second graph sheet is added when it is felt that the shape of the graphs (in particular the K_D vs. depth graph) may provide some additional indication (see p. 316 of the ASCE paper). The main graph sheet contains graphs of I_D , M , C_u , ϕ . As discussed before, a value of C_u is plotted only for $I_D \leq 1.2$ (but then no ϕ value is plotted) and a value of ϕ is plotted only for $I_D > 1.2$ (but then no C_u value is plotted).

A convenient spacing separating each one of the 4 graphs from the adjacent ones is 1 cm.

a. Vertical Axis

The following scales are recommended for the depth Z , depending on the maximum test depth below ground surface Z_{\max}

If $Z_{\max} < 6.5$ m	1 cm = 0.5 m
If $6.5 < Z_{\max} < 13$ m	1 cm = 1 m
If $13 < Z_{\max} < 39$ m	1 cm = 3 m

b. I_D plot - A fixed log scale, physically occupying 5 cm, is recommended. The upper and the lower horizontal sides of the graph should display the ticks and the numbers as indicated in Fig. 16 a & b including the indications CLAY SILT SAND to facilitate understanding this graph.

Note that the physical abscissa X (cm) from the left vertical side of this graph for a given I_D (for a 5 cm wide scale) is provided by the formula:

$$X \text{ (cm)} = 2.5 \text{ cm} \log \frac{I_D}{0.1}$$

Hence the ticks locate themselves at the following abscissas

I _D	.1	.2	.3	.4	.5	2	3	4	5	10
X(cm)	0	.75	1.19	1.51	1.75	3.25	3.69	4.01	4.25	5

and the two vertical dotted lines, corresponding to I_D = 0.6 and I_D = 1.8, at the abscissas 1.95 cm and 3.14 cm.

If I_D is plotted by hand the operator may find it convenient to use (a copy of) the card in Fig. 16a to identify the position of the data point at each depth.

c. M plot - The scale should be chosen in such a way to utilize the horizontal available space as much as possible but without leaving too many data points out of the graph. In general the most convenient scale is the one for which the number of data points falling outside the graph (and not plotted) is approximately 10% of the total number.

An arithmetic scale for M is recommended for the following reasons:

The arithmetic scale permits one to recognize particular laws of increase of M (e.g. a linear increase with depth) which may provide useful indications to the Engineer.

The arithmetic scale expresses more effectively the real variations of M in the various layers.

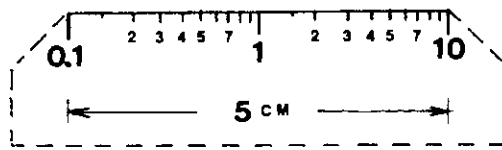

Fig. 16a "Cutout" scale for plotting I_D in a log scale.

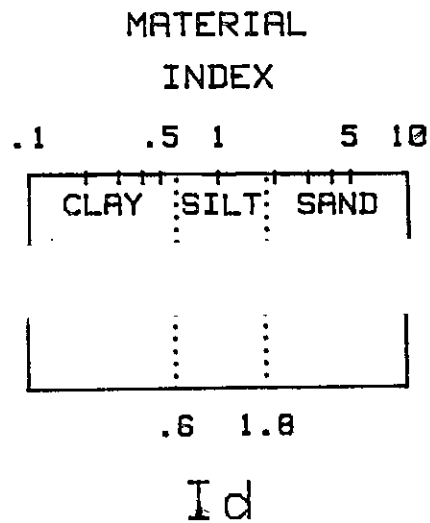

Fig. 16b "Cutouts" for top and bottom of I_D graph. Photocopy onto transparency material, trim and glue on graph sheet.

Experience has shown that a horizontal M scale physically occupying 5 cm of the sheet is convenient, in connection with one of the following full scale values (in bar): 50 100 250 500 1000 2500.

d. C_u plot - As above except that it may be better to choose the scale so that a smaller proportion (say 5% rather than 10%) of the data points is left outside the graph.

It is recommended that a horizontal C_u scale physically occupying 5 cm of the sheet, in connection with one of the following full scale values (in bar): .25 .5 1 2.5 5.

e. ϕ plot - A fixed scale physically occupying 4 cm of the sheet is recommended, extending from 25° to 45° .

NOTES

1. When at a given site more than one DMT test has been performed, it is convenient to adopt, for all the graphs, a unique scale both for the depth and all the involved parameters, in order to facilitate comparisons of the results.
2. The values of the various parameters in the Table should be rounded to avoid an unreasonable number of digits after the decimal point. The Table in Fig. 21 can be used as an example.
3. The data points falling outside the space allocated to each graph should not be plotted. However, the portion inside the graph of the straight line joining two points (one of which is outside the graph) should be plotted correctly (i.e. taking into account the proper position of the point outside the graph). If, at a given depth, a data point is available but the one above and the one below are not available, that data point should be plotted (isolated) and no joining lines should be drawn through that point.

4.8 Data Sheets, Sample Calculations, Sample Graphs of Results

This section contains:

- | | |
|---------|---|
| Fig. 17 | Field data sheet (blank) |
| Fig. 18 | Field data sheet, filled with sample data |
| Fig. 19 | Form for performing the data manually (blank) |
| Fig. 20 | Computer printout showing all input data and some preliminary calculation |
| Fig. 21 | Sample tabular output printed by computer |
| Fig. 22 | Sample diagrams plotted by computer. |

Figs. 18 20 21 22

all refer to the same example.

Firm: _____ Client: _____

Location: _____ Job: _____

Test Number _____

Date: _____ Comment _____

Depth to water _____ m Ground Elevation _____ m

	before	after
ΔA		
ΔB		

bar

Tip No. _____ Zero Gauge, Z_m _____ bar GAMTOP: t/m^3

0	A	B	7		14		21		28		35	
.2			.2		.2		.2		.2		.2	
.4			.4		.4		.4		.4		.4	
.6			.6		.6		.6		.6		.6	
.8			.8		.8		.8		.8		.8	
1			8		15		22		29		36	
.2			.2		.2		.2		.2		.2	
.4			.4		.4		.4		.4		.4	
.6			.6		.6		.6		.6		.6	
.8			.8		.8		.8		.8		.8	
2			9		16		23		30		37	
.2			.2		.2		.2		.2		.2	
.4			.4		.4		.4		.4		.4	
.6			.6		.6		.6		.6		.6	
.8			.8		.8		.8		.8		.8	
3			10		17		24		31		38	
.2			.2		.2		.2		.2		.2	
.4			.4		.4		.4		.4		.4	
.6			.6		.6		.6		.6		.6	
.8			.8		.8		.8		.8		.8	
4			11		18		25		32		39	
.2			.2		.2		.2		.2		.2	
.4			.4		.4		.4		.4		.4	
.6			.6		.6		.6		.6		.6	
.8			.8		.8		.8		.8		.8	
5			12		19		26		33		40	
.2			.2		.2		.2		.2		.2	
.4			.4		.4		.4		.4		.4	
.6			.6		.6		.6		.6		.6	
.8			.8		.8		.8		.8		.8	
6			13		20		27		34		41	
.2			.2		.2		.2		.2		.2	
.4			.4		.4		.4		.4		.4	
.6			.6		.6		.6		.6		.6	
.8			.8		.8		.8		.8		.8	

FIGURE 18

Firm: Schmertmann & Crapps Client: University of Florida

Location: GAINESVILLE, 16 NW 29th ST Job: Research project - FHA House

Test Number

D-1

Date: March 18-1981 Comment _____

Depth to water > 10 m

Ground Elevation / m

	before	after
ΔA	.15	.10
ΔB	.19	.32

bar assumed
.13
.23

Tip No. 61 Zero Gauge, Z_m .2 bar

0	A	B	7		14		21		28		35
.2	/	/	.2		.2		.2		.2		.2
.4	1.7	3.7	.4		.4		.4		.4		.4
.6	1.85	3.7	.6		.6		.6		.6		.6
.8	1.45	2.5	.8		.8		.8		.8		.8
1	1.55	2.55	8		15		22		29		36
.2	1.70	2.80	.2		.2		.2		.2		.2
.4	3.0	5.0	.4		.4		.4		.4		.4
.6	4.5	7.3	.6		.6		.6		.6		.6
.8	5.7	10.2	.8		.8		.8		.8		.8
2	8.3	12.4	9		16		23		30		37
.2	10.3	18.6	.2		.2		.2		.2		.2
.4	6.5	11	.4		.4		.4		.4		.4
.6	7.2	13.8	.6		.6		.6		.6		.6
.8	12.2	22.2	.8		.8		.8		.8		.8
3	13.1	23.3	10		17		24		31		38
.2	12.6	25.5	.2		.2		.2		.2		.2
.4	10.6	22.1	.4		.4		.4		.4		.4
.6	7.8	15.6	.6		.6		.6		.6		.6
.8	13.6	25.2	.8		.8		.8		.8		.8
4	14.8	29.5	11		18		25		32		39
.2	16.4	34.4	.2		.2		.2		.2		.2
.4	21.2	40	.4		.4		.4		.4		.4
.6			.6		.6		.6		.6		.6
.8			.8		.8		.8		.8		.8
5			12		19		26		33		40
.2			.2		.2		.2		.2		.2
.4			.4		.4		.4		.4		.4
.6			.6		.6		.6		.6		.6
.8			.8		.8		.8		.8		.8
6			13		20		27		34		41
.2			.2		.2		.2		.2		.2
.4			.4		.4		.4		.4		.4
.6			.6		.6		.6		.6		.6
.8			.8		.8		.8		.8		.8

```

REGISTR.n 22  Ditta$=UNIVERSITY OF FLORIDA  Numerova$=D-1  Giorno$=13 March 198
1
Committ$=SCHMERTMANN & CRAPPS  A1$=RESEARCH PROJECT-FHA HOUSE
A2$=GAINESVILLE,16 NW 29th Str.  Commento$=  N= 20
Zi= .4  Zf= 4.4  Zw= 10  Zass= 0  Multiolic= 37
Gamsup= 1.  Zm= .2  Deltaa= .13  Deltab= .23  Deltaagam= 0
mt.4  A( 0)= 1.7  B( 0)= 3.7  Po= 1.5  Pi= 3.3  Ed= 63.7
mt.6  A( 1)= 1.9  B( 1)= 3.7  Po= 1.7  Pi= 3.3  Ed= 57.9
mt.8  A( 2)= 1.5  B( 2)= 2.5  Po= 1.3  Pi= 2.1  Ed= 26.8
mt1.0  A( 3)= 1.6  B( 3)= 2.6  Po= 1.4  Pi= 2.1  Ed= 24.9
mt1.2  A( 4)= 1.7  B( 4)= 2.8  Po= 1.6  Pi= 2.4  Ed= 28.7
mt1.4  A( 5)= 3.0  B( 5)= 5.0  Po= 2.9  Pi= 4.6  Ed= 63.7
mt1.6  A( 6)= 4.5  B( 6)= 7.3  Po= 4.3  Pi= 6.9  Ed= 94.8
mt1.8  A( 7)= 5.7  B( 7)= 10.2  Po= 5.4  Pi= 9.8  Ed= 160.8
mt2.0  A( 8)= 8.3  B( 8)= 12.4  Po= 8.0  Pi=12.0  Ed= 145.3
mt2.2  A( 9)= 10.7  B( 9)= 18.6  Po= 9.8  Pi=18.2  Ed= 308.5
mt2.4  A(10)= 8.5  B(10)= 11.0  Po= 6.2  Pi=10.6  Ed= 160.8
mt2.6  A(11)= 7.2  B(11)= 13.8  Po= 6.8  Pi=13.4  Ed= 242.4
mt2.8  A(12)= 12.2  B(12)= 22.2  Po=11.6  Pi=21.8  Ed= 374.5
mt3.0  A(13)= 13.1  B(13)= 23.3  Po=12.5  Pi=22.9  Ed= 382.3
mt3.2  A(14)= 12.6  B(14)= 25.5  Po=11.9  Pi=25.1  Ed= 487.2
mt3.4  A(15)= 10.6  B(15)= 22.1  Po=10.0  Pi=21.7  Ed= 432.8
mt3.6  A(16)= 7.8  B(16)= 15.6  Po= 7.4  Pi=15.2  Ed= 239.0
mt3.8  A(17)= 13.6  B(17)= 25.2  Po=13.0  Pi=24.8  Ed= 436.7
mt4.0  A(18)= 14.8  B(18)= 29.5  Po=14.0  Pi=29.1  Ed= 557.1
mt4.2  A(19)= 16.4  B(19)= 34.4  Po=15.4  Pi=34.0  Ed= 695.3
mt4.4  A(20)= 21.2  B(20)= 40.0  Po=20.2  Pi=39.6  Ed= 716.4

```

Fig.20 Example of computer printout showing all input data and some preliminary calculation, including E_D values. (Note all $E_D > 0$).

UNIVERSITY OF FLORIDA
SCHMERTMANN & DRAPPS
GAINESVILLE, 16 NW 29th Str.

DILATOMETER TEST N.D-1
RESEARCH PROJECT-FHA HOUSE

TEST PERFORMED 13 March 1981
Test depth: m 4 to m 4.4
Water table m 10

Po = Corrected A reading Kg/sqcm
P1 = Corrected B reading Kg/sqcm
Gamma = Bulk unit weight t/cu m
Sigma' = Effective overb. stress Kg/sqcm
U = Pore pressure Kg/sqcm
Id = Material Index (-)
Kd = Horizontal stress index (-)
Ed = Dilatometer modulus Kg/sqcm

INTERPRETED GEOTECHNICAL PARAMETERS

Ko = In situ earth press. coeff. (-)
Ocr = Overconsolidation ratio (-)
q = Eroded overburden above p.s. Kg/sqcm
M = Constrained modulus (Sigma') Kg/sqcm
Cu = Undrained cohesion (cohesive) Kg/sqcm
Fi = Friction angle (cohesionless) (-)

m	Po	P1	Gamma	Sigma'	U	Id	Kd	Ed	Ko	Ocr	q	M	Cu	Fi	DESCRIPTION
.4	1.5	3.3	1.70	.07	0.0	1.11	22.8	64	3.0	44.4	3.0	209	.31		SILT, LOW DENSITY
.6	1.7	3.3	1.70	.10	0.0	.92	16.7	58	2.5	27.5	2.7	173	.32		SILT, LOW DENSITY
.8	1.3	2.1	1.60	.14	0.0	.54	9.9	27	1.8	12.1	1.5	67	.22		SILTY CLAY, SOFT
1.0	1.4	2.1	1.60	.17	0.0	.46	8.6	25	1.7	9.9	1.5	58	.23		SILTY CLAY, SOFT
1.2	1.6	2.4	1.60	.20	0.0	.49	8.0	29	1.6	8.6	1.5	55	.25		SILTY CLAY, SOFT
1.4	2.8	4.6	1.70	.23	0.0	.60	12.3	64	2.1	17.0	3.7	172	.49		CLAYEY SILT, LOW DENSITY
1.6	4.3	6.9	1.80	.27	0.0	.59	16.2	95	2.5	26.1	6.7	284	.80		SILTY CLAY MED CONSIST
1.8	5.4	9.8	1.80	.30	0.0	.80	18.0	161	2.6	30.7	9.0	491	1.03		SILT, MEDIUM DENSITY
2.0	8.0	12.0	1.90	.34	0.0	.49	23.8	145	3.1	47.6	15.8	492	1.64		SILTY CLAY GOOD CONSIST
2.2	9.8	18.2	1.95	.38	0.0	.85	26.2	308	3.2	55.2	20.4	1052	2.06		SILT, DENSE
2.4	6.2	10.6	1.95	.42	0.0	.70	15.0	161	2.4	23.2	9.2	464	1.13		CLAYEY SILT, DENSE
2.6	6.8	13.4	1.95	.45	0.0	.96	15.0	242	2.4	23.2	10.1	699	1.24		SILT, DENSE
2.8	11.6	21.8	2.10	.49	0.0	.87	23.6	375	3.1	47.1	22.7	1241	2.38		SILT, VERY DENSE
3.0	12.5	22.9	2.10	.54	0.0	.82	23.4	382	3.0	46.5	24.3	1264	2.55		SILT, VERY DENSE
3.2	11.9	25.1	2.10	.58	0.0	1.11	20.6	487	2.8	38.1	21.4	1552	2.35		SILT, VERY DENSE
3.4	10.0	21.7	2.10	.62	0.0	1.17	16.1	473	2.5	25.9	15.4	1277	1.85		SILT, VERY DENSE
3.6	7.4	15.2	1.95	.66	0.0	1.06	11.1	289	2.0	14.6	9.0	752	1.24		SILT, DENSE
3.8	13.0	24.8	2.10	.70	0.0	.91	18.5	437	2.7	32.2	21.9	1347	2.49		SILT, VERY DENSE
4.0	14.0	29.1	2.10	.74	0.0	1.07	18.9	557	2.7	33.2	23.9	1720	2.70		SILT, VERY DENSE
4.2	15.4	34.0	2.10	.78	0.0	1.20	19.7	685	2.8	35.5	27.0	2153	3.01		SILT, VERY DENSE
4.4	20.2	39.6	2.10	.83	0.0	.96	24.5	716	3.1	49.7	40.2	2398	4.16		SILT, VERY DENSE
m	Po	P1	Gamma	Sigma'	U	Id	Kd	Ed	Ko	Ocr	q	M	Cu	Fi	DESCRIPTION

FIGURE 21 TABULAR OUTPUT PRINTED BY COMPUTER

INTERPRETED GEOTECHNICAL PARAMETERS

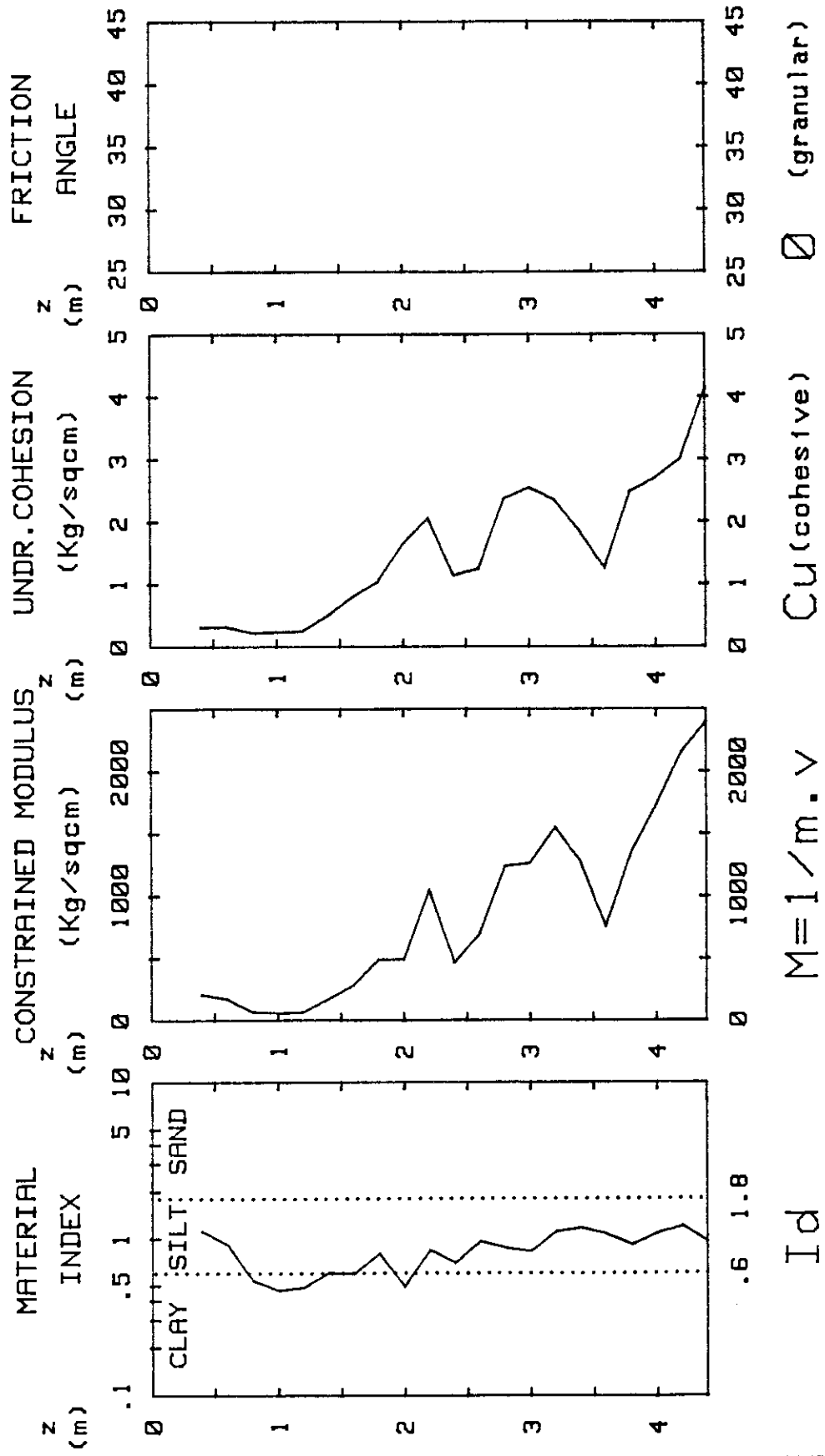

FIGURE 22 SAMPLE RESULTS PLOTTED BY COMPUTER

5.1 Settlement Analysis Based on M(*)

5.1.1 "One dimensional" method: This method is the most widely used for settlement computation when oedometer results are available. The compressible soil under the foundation is first subdivided into a number of layers so that in each layer (of thickness ΔZ_i) M_i (determined either by oedometer or by DMT) is approximately constant. Then the settlement ρ_{od} (od = one dimensional) is calculated as:

$$\rho_{od} = \sum \frac{\Delta \bar{\sigma}_{zi}}{M_i} \Delta Z_i \quad (5.1)$$

In Eq.5.1 $\Delta \bar{\sigma}_{zi}$ is the increase of vertical stress at mid-height of the layer, estimated using the Boussinesq influence coefficients for vertical stress according to the formula

$$\Delta \bar{\sigma}_{zi} = I_{\sigma_z} \cdot \Delta p \quad (5.2)$$

where

- Δp = surface load applied by the foundation (often only the increase from pre-construction to post-construction is considered)
- I_{σ_z} = influence coefficient for vertical stress increase, function of the relative depth H/R (circular footing) or H/B (rectangular footing). These coefficients are reproduced in Fig. 23a and b. Note that they refer to the center of the foundation, where the maximum settlement usually occurs.

*Comments on the choice of $M = 1/m_v$ from dilatometer results are given in section 4.5.3.

(a) Circular area of radius R $I_{\sigma_z} = 1 - [1 + (R/Z)^2]^{-1.5}$

(b) Rectangular area

Z/B	L/B = 1	L/B = 2	L/B = 3	L/B = 4	L/B = 5
0	1.0000	1.0000	1.0000	1.0000	1.0000
0.1	0.9943	0.9966	0.9966	0.9968	0.9968
0.2	0.9604	0.9757	0.9768	0.9772	0.9768
0.3	0.8903	0.9304	0.9350	0.9356	0.9331
0.5	0.7009	0.7998	0.8136	0.8167	0.8176
1.0	0.3361	0.4807	0.5249	0.5398	0.5451
1.5	0.1774	0.2910	0.3467	0.3705	0.3820
3.0	0.0502	0.0943	0.1294	0.1542	0.1714

Fig. 23 Influence coefficients I_{σ_z} to be used with Eq. 5.2 for computing vertical stress under the center of uniformly loaded areas

<u>Circular footing</u>	Flexible, center	1	
	Flexible, periphery	0.64	
	Rigid	0.785	
<u>Rectangular footing</u>	L/B	Center	Corner
(L > B)	1	1.12	0.56
	1.5	1.36	0.68
	2	1.53	0.76
	3	1.77	0.88
	4	1.95	0.98
	5	2.1	1.05

Fig. 24 Coefficients I for computing settlements with Eq. 5.6 for homogeneous compressible layer of infinite thickness

Notes

- (1) The key points on which the "one dimensional method" is based are:
- Ignore the influence of the variation of horizontal stresses on vertical strain.
 - Use the constrained modulus M instead of Young's modulus E , thereby compensating, at least partially, for point a.
- (2) When oedometer results are available, Eq. 5.1 is more frequently written in the (equivalent) form:

$$\rho_{od} = \sum \Delta Z \frac{C}{1+e} \log \frac{p+\Delta p}{p} \quad (5.3)$$

Alternatively M is calculated from the relevant portion of the oedometer curve (having compression index C) as:

$$M = 2.3 p(1+e)/C \quad (5.4)$$

and then is used with Eq. 5.1.

- (3) If the load is applied at some depth below ground surface, the Fox depth reduction factor should be applied to ρ_{od} . This factor varies between 0.5 (very deep foundation) to 1. In shallow foundation this factor is usually very close to 1. If the foundation is rigid, the stiffness correction factor should be applied to the settlement calculated under the center of the foundation using the hypothesis of uniform applied load. This factor is typically in the range of 0.7 to 0.9.
- (4) In sands, ρ_{od} is the total expected settlement. This settlement occurs as the load is applied.

(5) In clays, if 3 dimensional effects are important (say if thickness of compressible layer is more than twice ^{the} footing width) the total final settlement is given by

$$\rho_t = \rho_i + \mu_{SK} \rho_{od} \quad (5.5)$$

where

ρ_i = initial settlement occurring in undrained conditions. According to Burland (State-of-the-Art: "Behavior of Foundations and Structures", 9th ICSMFE, Tokyo, 1977, pp. 513, 514, 518) ρ_i/ρ_{od} is usually in the range of 0.5 to 2 (the fraction assumes the higher values when the compressible layer is thick compared to the footing width).

μ_{SK} = reduction factor (Skempton, A.W. and Bjerrum L., "A Contribution to the settlement analysis of foundations on clay", Geotechnique, Vol. 7, No. 4, pp. 168-178) accounting for 3D loading effects. This factor is a function of the shape of the loaded area (circular, strip load), of the relative thickness of the layer and of the Skempton A parameter. Typical values of μ_{SK} are: for lightly OC clays 0.6 to 0.8, for heavily OC clays 0.2 to 0.4.

A form facilitating the computations according to the outlined procedure is reproduced in Fig. 25. The form can handle up to 5 layers. For each one soil properties are considered uniform. The upper table of the form contains:

- (1) depths
- (2) relative depths to centers of each layer (to be entered in Boussinesq charts)
- (3) Which fraction of the surface load reaches the center of each layer (= influence values read from Boussinesq charts)
- (4) increase in vertical stress at the center of each layer
- (5) effective stress due to the self weight of each layer
- (6) Initial effective vertical geostatic stress (accumulation of 5)
- (7) Repeats (4)
- (8) Final effective vertical stress $\bar{\sigma}'_{v_2}$ (6+7)

The lower table repeats some of the information above. Then:

- (6) Maximum past pressure p_{CD} from DMT
- (7) Ratio p_{CD} over final effective vertical stress σ'_{v_2}
This ratio must be somewhat higher than unity e.g. $p_{CD}/\sigma'_{v_2} > 1.2$.
Otherwise p_c is exceeded and M from dilatometer is not applicable (too high).
- (8) Vertical strain ϵ
- (9) Compression (reduction in thickness) of each layer $\epsilon \Delta Z$

The summation of column (9) is the conventional one dimensional consolidation settlement, to which the Skempton-Bjerrum correction and others if appropriate are then applied.

The form allows calculations for two applied loadings. Note that while many of the calculated quantities for two loadings are related (e.g. stress increments and strains are directly proportional to load) the condition $p_{CD}/\sigma'_{v_2} > 1.2$ may be verified for the lighter loading and not for the heavier one. Therefore that condition must be checked independently for both loadings.

FIGURE 25

SCHMERTMANN & CRAPPS, INC. Job No. _____

ANALYSIS p. _____ of _____

Problem: CALCULATIONS FOR $\Delta\rho$ FROM DMT
DATA AT SOUNDING NO. _____

Work by: _____ date: _____

Check by: _____ date: _____

CALC. OF $\Delta\sigma_v$ @ z

$B_{load\ I} =$ _____ ft _____ m
 $B_{load\ II} =$ _____ ft _____ m

(assumes elastic, surface load, uniform load,
 can calc. for 2 loadings, 5 sublayers)

depth (elev)	$L/B =$	z/B	$\frac{\Delta\sigma_v}{q}$	q ()	$\Delta\sigma_v$ ()	$\sum \Delta\sigma_v + \sigma_{v1}' = \sigma_{v2}'$ ()
Sublayer ①	z_1	I				
		LOAD I				
		LOAD II				
Sublayer ②	z_2	I				
Sublayer ③	z_3	I				
Sublayer ④	z_4	I				
Sublayer ⑤	z_5	I				
		II				

elev/depth (ft)(m)(cm)	sub-layer No.	Δz cm in	$\sum \Delta\sigma_v$	σ_{v2}' ()	ρ_{CD}	$\frac{\rho_{CD}}{\sigma_{v2}'}$	\bar{M}_D ()	$\bar{E} = \frac{\Delta\sigma_v}{M}$	$\sigma_{\rho} = E \Delta z$	Notes
	①									
	②									
	③									
	④									
	⑤									

$\Delta\rho =$ _____ cm
 _____ in

CORRECTIONS TO $\Delta\rho$ - 1D method

1. 3-D OC effects ($Sk-B_j$)

3. Layering E_1/E_2 effects on $\Delta\sigma_v$

2. addit./removal overburden

4. Other

CORR. $\Delta\rho =$ _____ cm
 _____ in

5.1.2 "Integral formulae method": When the modulus M of the compressible layer is approximately constant, the total final drained settlement can be calculated faster using elastic theory integral formulae having the form

$$s_t = I \frac{\Delta p (1 - \bar{\mu}^2)}{\bar{E}} \cdot B \quad (5.6)$$

where B is the short side (or diameter) of the footing. These formulae apply both to sands and clays, provided \bar{E} and $\bar{\mu}$ are the Young's modulus and Poisson's ratio respectively of the soil skeleton. Eq. 5.6 requires a value for $\bar{\mu}$ (in absence of specific determinations the value 0.3 is often used). Then \bar{E} can be computed from M using the theory of elasticity:

$$\bar{E} = \frac{(1 + \bar{\mu})(1 - 2\bar{\mu})}{(1 - \bar{\mu})} M \quad (5.7)$$

For $\bar{\mu} = 0.3$, $\bar{E} = 0.74 M$.

The coefficients I to be used with Eq. 5.6 are available for a wide variety of combinations of shape of footing/depth of the compressible layer. Fig. 24 reproduces some I values for the case of homogeneous compressible layer of infinite depth. A useful series of I values for the case of a homogeneous soil layer of finite thickness, computed by Ueshita and Meyerhof, is reproduced on p. 117 of the book: "Elastic Solutions for Soil and Rock Mechanics" byoulos and Davis, John Wiley & Sons.

The notes (3), (4), (5) ending the previous section (5.1.1) apply even if the settlement computed by this method, noting however that Eq. 5.1 provides s_{od} , Eq. 5.6 provides s_t .

5.2 Horizontal Stresses Against Piles Driven in Sand

Various methods for the evaluation of the ultimate lateral skin friction f_s of piles driven through sand are based on the formula:

$$f_s = K\bar{\sigma}_v \tan\delta = \bar{\sigma}_{hp} \tan\delta \quad (5.8)$$

where:

$$K = \bar{\sigma}_{hp} / \bar{\sigma}_v \text{ (ratio after pile driving)}$$

$\bar{\sigma}_v$ = vertical effective stress

$\bar{\sigma}_{hp}$ = horizontal effective stress applied by sand to pile

δ = friction angle between sand and pile material

The use of Eq. 5.8 requires the evaluation of K, whose selection is sometimes problematic. It is suggested herein that the product $K\bar{\sigma}_v = \bar{\sigma}_{hp}$ in Eq. 5.8 be evaluated as:

$$\bar{\sigma}_{hp} = C(p_o - u_o) \quad (5.9)$$

where:

p_o = corrected first reading of dilatometer (see Eq. 4.2)

u_o = pore water pressure prior to dilatometer insertion

Note: p_o and u_o can be read directly from the DMT tabular output

C = reduction factor accounting for relaxation with time of the horizontal stress against the pile sides as a consequence of sand creep. Suggested value for C is 0.75

Eq. 5.9 is proposed only for freely draining sands. In such sands $p_o - u_o$ is the effective horizontal stress against the dilatometer. Since $\bar{\sigma}_h$ increases with the cross section of the penetration body, the assumption $\bar{\sigma}_{hp} = p_o - u_o$ is conservative. On the other hand, in sands where an excess Δu is still present at the time of p_o reading, Eq. 5.9 is not applicable. However in such sands the DMT can be performed at a slower rate, so that test conditions are drained. One way of insuring drained test conditions is to perform subsequent DMT soundings, increasing each time the delay time between end of penetration and p_o reading. When the delay time is such that a further increase in delay time does not alter p_o appreciably, test conditions are drained and the p_o values obtained from such tests can be used in Eq. 5.9.

6.1 Derivation of the Formulas for p_0 , p_1 , E_D

The function of the feeler (Fig. 26) is to improve the definition of the instant at which the electrical circuit is interrupted. However the fact that the feeler is 0.05 mm above the disc must be accounted for when evaluating p_0 (total horizontal soil pressure against side of dilatometer or contact pressure at soil membrane interface before any displacement of the membrane). Fig. 26 shows the geometry of the sensing disc. The value of p_0 can be calculated by reverse extrapolation (Fig. 27) assuming a linear relationship between contact pressure at soil membrane interface and movement of the membrane center(*).

At the instant of the first reading (A) the contact pressure is $A - Z_M + \Delta A$ (Fig. 27). At the instant of the second reading (B) the contact pressure is $B - Z_M - \Delta B$. By reverse extrapolation, as shown in Fig. 27), the contact pressure for zero movement p_0 is:

$$p_0 = (A - Z_M + \Delta A) - \frac{5}{105} [(B - Z_M - \Delta B) - (A - Z_M + \Delta A)] \quad (6.1)$$

or

$$p_0 \approx 1.05 (A - Z_M + \Delta A) - 0.05 (B - Z_M - \Delta B) \quad (6.2)$$

$$p_1 \text{ is simply } B - Z_M - \Delta B \quad (6.3)$$

(*) The (axis to axis) distance between feeler and plexiglass cylinder is small (35 mm) compared to the diameter of the membrane (60 mm). Moreover both feeler and cylinder are in the zone where the displacement of the membrane is maximum and has ^{minimum} variability. Hence it may be assumed, with good approximation, that both elements monitor the movement of the center of the membrane.

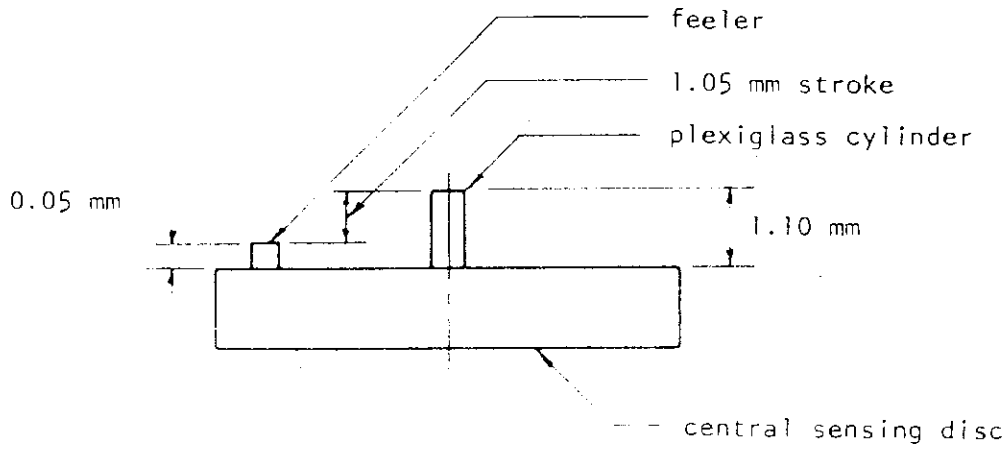
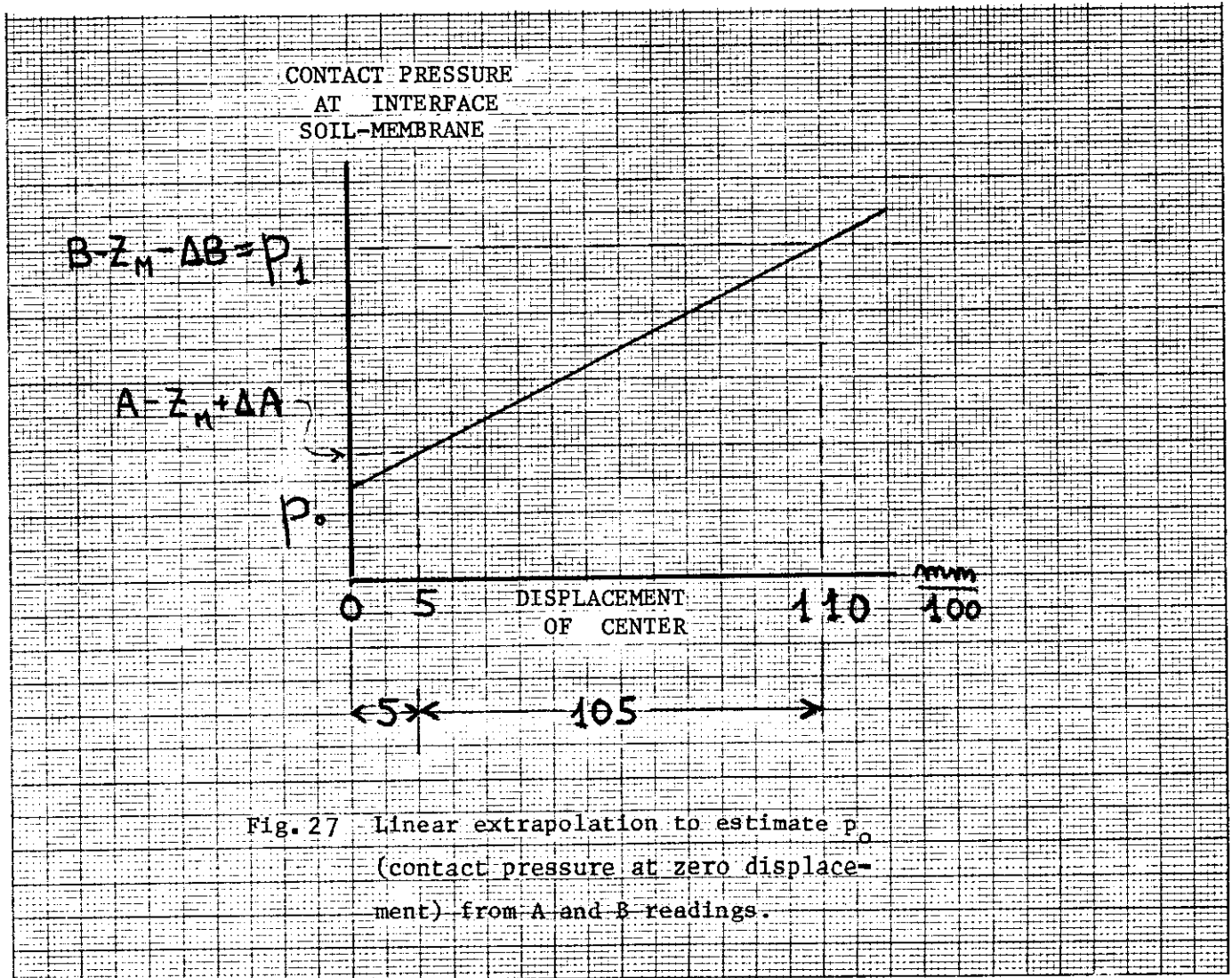

FIGURE 26 VERTICAL DIMENSIONS ABOVE SENSING DISC OF FEELER AND PLEXIGLASS CYLINDER AT "B" READING



Since the displacement of the membrane center corresponding to the pressure increase from p_o to p_1 is $S_o = 1.10$ mm, Eq. 3 of the ASCE paper becomes

$$E_D = 34.7 \Delta p \quad (6.4)$$

Note: In a previous design, the outer surface of the sensing disc was slightly tapered, the disc being 0.10 mm thicker at center than at the periphery. For that geometry the appropriate expressions for p_o , p_1 , E_D are the following:

$$p_o = A - Z_M + \Delta A \quad (6.5)$$

$$p_1 = B - Z_M - \Delta B \quad (6.6)$$

$$E_D = 37 \Delta p \quad (6.7)$$

6.2 Derivation of Drained Clay Modulus From Undrained Membrane Expansion

Considering the duration of the test, both dilatometer penetration and membrane expansion in clay occur in undrained conditions. A question of considerable interest is why the modulus inferred from the undrained expansion of the membrane correlates well with the tangent constrained modulus M which is a drained modulus. A possible qualitative explanation is offered below.

During the penetration, the maximum lateral soil displacement is 7 mm. During membrane expansion the maximum lateral soil displacement is 1 mm. Therefore, compared with what happened before, the membrane expansion produces small strains, which suggests the use of elastic theory to interpret membrane expansion. Also, if several expansion cycles are performed or a given depth, ^{the measured} Δp values (and moduli) do not vary considerably in subsequent cycles, lending support to the use of elastic theory to interpret membrane expansion. According to the elastic theory, undrained and drained elastic constants are related. In fact the undrained shear modulus G_u is equal to the drained shear modulus \bar{G} (water cannot take shear stress) (*). Since the general expression of G in terms of E and μ is $G = 1/2 E/(1+\mu)$, the equation $G_u = \bar{G}$ is equivalent to

$$\frac{E_u}{1+\mu_u} = \frac{\bar{E}}{1+\bar{\mu}} \quad (6.8)$$

where $\mu_u = 0.5$.

According to the elastic theory the confined modulus M and the Young's modulus \bar{E} of the skeleton are related by the following equation:

$$M = \frac{\bar{E}}{1 - \frac{2\bar{\mu}}{1 - \bar{\mu}}} \quad (6.9)$$

*It is well established that Eq. 6.8, derived from the theory of elasticity, "does not work" when loading two identical samples drained and undrained respectively. However the membrane expansion considered herein occurs in reloading (see Section 6.3). Skempton and Sowa (Geotechnique, 1963) showed that weald clay specimens, when reloaded, exhibited $A = 1/3$, typical of elastic materials. This evidence supports the applicability of Eq. 6.8 to reloading, at least for approximate evaluations.

Since the dilatometer modulus E_D provides in general the ratio $E/(1-\mu^2)$ of the soil facing the membrane and since the controlling E and μ during DMT in clay are E_U and $\mu_U = 0.5$, E_D provides in undrained conditions the ratio $E_U/(1-\mu_U^2) = E_U/0.75$ or:

$$E_U = 0.75 E_D \quad (6.10)$$

If this expression of E_U is substituted for E_U in Eq. 6.8 and \bar{E} is eliminated by combining Eqs. 6.8 and 6.9, the following expression for the ratio $R_M = M/E_D$ is obtained:

$$R_M = \frac{M}{E_D} = \frac{0.5(1+\bar{\mu})}{1-2\frac{\bar{\mu}^{-2}}{1-\bar{\mu}}} \quad (6.11)$$

according to which R_M increases with $\bar{\mu}$ as follows

$\bar{\mu}$	0.30	0.35	0.40	0.45
R_M	0.88	1.08	1.50	2.75

These "theoretical" R_M values are in good agreement with the experimental data points in Fig. 13a of the ASCE paper, especially if it is accepted that $\bar{\mu}$ increases with OCR, as often suggested (OCR increases soil tendency to dilate).

Notes:

1. The above reasoning simply lends some support to the existence of a theoretical relationship between E_D (determined in undrained conditions) and the drained modulus of the soil in the "bulb" facing the membrane (Fig. 28). However this soil has been prestrained by the penetration and, in order to derive a direct correlation between M of the original soil and E_D , the prestraining should be accounted for. Until a quantitative interpretation of the prestraining becomes available,

the most useful way of relating M to E_D remains the direct experimental correlation.

2. In soils having appreciable structure/cementation/interlocking (in such soils K_D is high) it is expectable that prestrain due to penetration will considerably decrease the original modulus. This may be one of the reasons why R_M (factor to be applied to E_D to get M) is observed to increase with K_D (see data points in Fig. 13a of the ASCE paper).

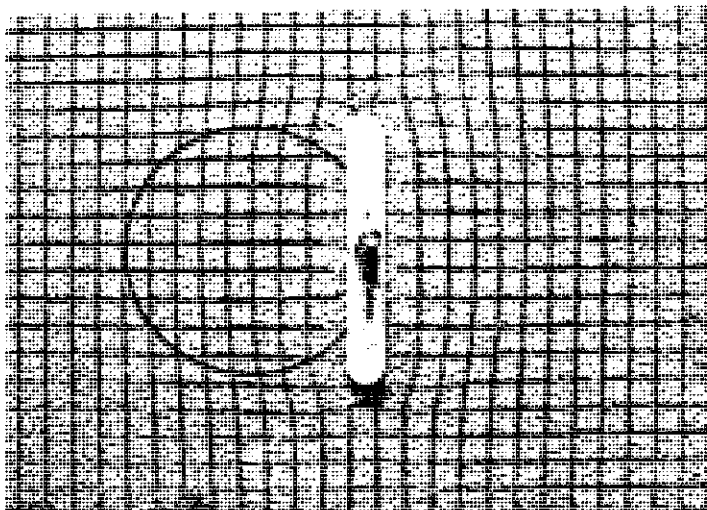

Fig. 28 Distorsions due to penetration in the "bulb" facing the membrane.

6.3 E_D as a Reloading Modulus

Illustrated below are ~~three~~ considerations all indicating that the membrane expansion tests the soil in reloading.

1. Fig.29_a shows that, as the dilatometer penetrates, the adjacent soil elements are imposed a curvature whose sign is later reversed. Therefore the membrane expansion produces "reloading" of the soil.
2. An apparent contradiction when testing sands is the following:
 - a. The horizontal pressure p_0 against the dilatometer, which displaces horizontally the soil initially on the vertical axis of 7 mm, is relatively low (e.g. 3 bar)
 - b. To displace the membrane (and soil) an additional 1 mm requires a Δp quite high (e.g. 20 bar), seemingly disproportionate compared with the modest increase in displacement (from 7 to 8 mm).

This apparent disproportion suggests that the low pressure p_0 against the plate is a consequence of an unloading situation.

3. ^{There} can be little doubt that the contact pressure in points such as B (Fig.29a) is much higher than in A.

* The^s stress strain considerations are of a very broad nature. For instance the "average" soil element to which these considerations refer is not readily identifiable. In fact the membrane loads a soil "bulb" which is only a portion of the soil mass affected by the penetration. Also the distortion imposed by the membrane expansion is not the "continuation" of the distortion imposed by the penetration.

A possible shape of the stress-strain curve for the "average" soil element tested by DMT is shown in Fig. 29b. One consequence of E_D being a reloading modulus (following the formation of the cavity open by the DM penetration) is the possible existence of a correlation between E_D and the reloading modulus determined by SBPM (Self boring pressuremeter) as shown in Fig. 29c. Investigations are in progress (at UBC) to find out the degree of correlation between these moduli.

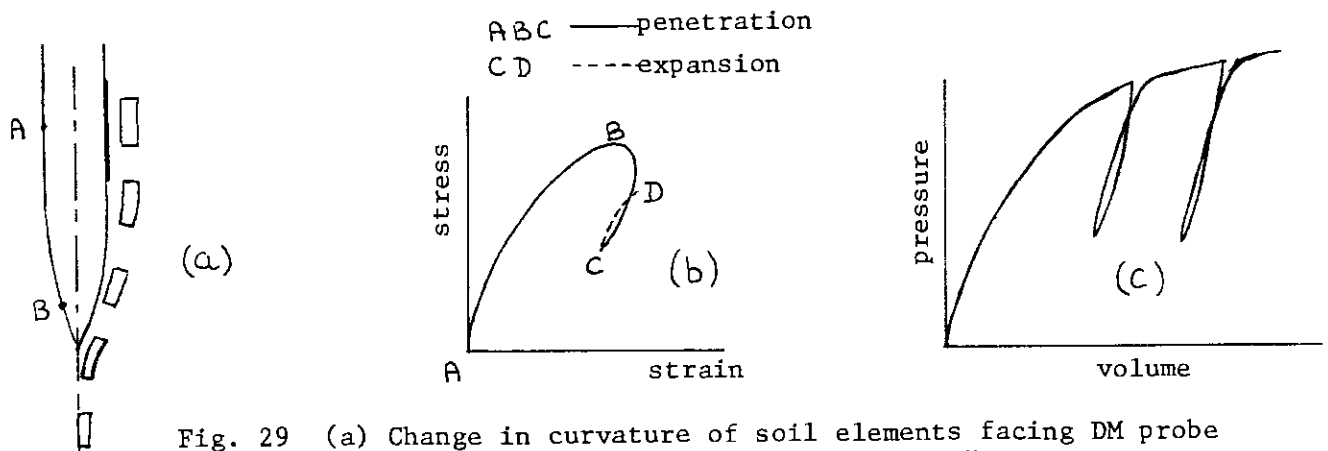

Fig. 29 (a) Change in curvature of soil elements facing DM probe
(b) Stress-strain curve for the "average" soil element tested by DMT.
(c) SBPM p-v curve, with loading/reloading cycles.

6.4 Sensitivity in M and C_u Determinations

6.4.1 Sensitivity in M determinations: The sensitivity (minimum detectable difference) in the M (or E_D) determination is substantially controlled by the uncertainty of the sum $(\Delta A + \Delta B)$. In fact E_D (see Eq. 4.3a and 4.6) is proportional to $[B - A - (\Delta A + \Delta B)]$ and the uncertainty in $B - A$ is usually smaller than the uncertainty in $(\Delta A + \Delta B)$. In most cases the change in the sum $(\Delta A + \Delta B)$ before and after testing is within 0.10 bar. However, to be safe, consider the extreme case of a change equal to 0.20 bar (i.e. ± 0.10 bar from the average value of $\Delta A + \Delta B$ used for calculating E_D). According to Eq. 4.6, the uncertainty of ± 0.10 bar in $(\Delta A + \Delta B)$ is reflected in an uncertainty of ± 3.5 bar in the figures expressing E_D (and a similar uncertainty applies to M). A more typical value of the uncertainty in E_D and M is ± 2 bar.

6.4.2 Sensitivity in c_u determinations: The value of c_u provided by DMT is based on p_o (see footnote on section 4.5). The quantity p_o (see Eq. 4.2) is essentially a function of A, Z_M and ΔA . The varia-

bility of ΔA is very small (usually less than 0.03 bar before and after testing). Also Z_M is not likely to vary to a discernable extent during a sounding. Therefore the uncertainty in p_o is controlled by the uncertainty in A and therefore by the accuracy of the gauge. The typical accuracy with which A is measured with the 40 bar gauge is ± 0.10 bar, which, considering that in many clays $c_u = 1/8$ to $1/10$ of $p_o - u_o$, is reflected in an uncertainty in c_u of ± 0.01 bar.

However to insure this high accuracy the operator must keep the rate of pressure increase within the limits specified in section 2.13.

6.5 Recommendations for Computer Programs for Dilatometer

This section provides recommendations independent of the particular computer used. Sometimes reference is made to the set of computer programs written by Marchetti for the system Hewlett Packard 9845B, but only for illustration purposes.

These recommendations refer to the more general case of a computer configuration as indicated in item 4.4c. If a smaller capacity is available ignore the recommendations referring to computer capabilities (e.g. plotting) which are not available.

A convenient way of organizing the automatic reduction of the data is to use 5 distinct computer programs performing the tasks illustrated below.

6.5.1 Program No. 1 (input of data, e.g. HP "REG" program) The functions of this program are as follows:

6.5.1.1 Input of data: all the data relative to one sounding are introduced. These are:

- Headlines and titles
- Calibration constants ΔA and ΔB
- Zero of the pressure gauge Z_M
- Initial test depth (Z_i) and final test depth (Z_f) below ground level (where $Z = 0$)
- Depth of ground water table Z_w below ground level
- Average bulk natural unit weight (measured or estimated) of soil above initial test depth Z_i . This unit weight is necessary to calculate the total soil vertical stress σ_v at Z_i (alternatively, σ_v at Z_i may be input).

6.5.1.2 Print data: all the data relative to one sounding are printed to enable checking to see if they have been inputted correctly. Moreover, a preliminary partial calculation should be performed and the results printed. The printout should include:

number of negative values of E_D , the minimum (negative) value of E_D , the values of ΔA and ΔB and their sum, how much this sum should be reduced (reduction = $E_{D, \min}/36.4$ or $\Delta P \min/1.05$) in order to get all E_D positive. If some negative E_D values are produced, the operator, after having rechecked the correctness of the input data, will select improved values of ΔA and ΔB , following the criteria illustrated in the manual, so as to reduce the sum $\Delta A + \Delta B$ as needed.

6.5.1.3 Correction of data: at this stage, with all the input data in the central memory, the operator can rectify, if necessary, the data. He can also ask a new printout of the rectified data as described in 6.5.1.2. When all the input data are satisfactory, the operator gives the command to proceed.

6.5.1.4 Storage of the data: all the data relative to one sounding are stored on tape (or other storage device) in a location identified by an address (registration number) associated with that sounding. The operator must keep a table of the correspondence between the registration numbers and the soundings, for later use. Alternatively he can get an updated Table from the computer using the program in Section 6.5.5. The Hewlett Packard system (9845B+2631G printer + 7225A plotter) for which the HP programs were developed uses cassettes each containing the data of more than 100 soundings 40 m long (approximate cost of a cassette \$30).

6.5.2 Program No. 2 (rectifications of data, e.g. HP "CORREZ" program) Sometime after the data relative to one sounding have been stored on tape the operator may desire to rectify some of them (e.g. Z_w = depth of ground water table when piezometric readings become available, or some of the titles etc.). This program permits these rectifications through the following steps:

- 6.5.2.1 The operator selects and inputs the registration number of the sounding he desires to rectify.
- 6.5.2.2 The data of that sounding are read from the tape.
- 6.5.2.3 The old data are displayed or printed and the operator rectifies them as needed.
- 6.5.2.4 The new data are overwritten on the same tape location.

6.5.3 Program No. 3 (data reduction and tabular output, e.g. HP "ELAB" program)

- 6.5.3.1 The operator selects and inputs the registration number identifying the sounding he wants to reduce.
- 6.5.3.2 All data relative to that sounding are read from tape.

6.5.3.3 The following calculation loop is performed at each test depth Z:

- calculate p_o, p_1, u_o, I_D, E_D at depth Z
- based on I_D, E_D and using a calculation routine equivalent to the chart in the manual, select gamma and soil description
- update σ_v (total vertical soil stress) by addition of gamma x depth interval
- calculate $\bar{\sigma}_v = \sigma_v - u_o, K_D, K_o, OCR, q, M$
- if $I_D > 1.2$ calculate ϕ , if $I_D \leq 1.2$ calculate C_u
- check if calculated values are within the range of the correlations. Report values outside the range as specified in the manual. An example of subroutine performing this check is found at the end of the "ELAB" program. Example:

```

if  $K_D > 99.9$  the printout will be "> 99.9"
 $I_D < 0$  " " " " 0

```

All parameters which are inherently positive are put equal to zero if the calculated value is negative

- Print one line of the tabular output

6.5.3.4 The values of the parameters to be plotted in the next program are stored.

The calculation loop in 6.5.3.3 is central to the data reduction process. It is also probably the most readily adaptable to various computer languages.

6.5.4 Program No. 4 (plot diagrams, e.g. HP "PLOT" program)

This program can either be separated or attached to the previous one. In any case the linkage must be such as to permit the use of the parameters stored in memory at the end of the previous program. This program plots diagrams according to the recommendations indicated in the manual.

In the diagrams whose scale is not fixed, the computer selects automatically by trial and error a convenient scale. For a given scale the percentage of data points which would fall outside the diagram is calculated. If this percentage is as specified that particular scale is adopted.

In general it is convenient that the vertical axis of the diagrams extend from $Z = 0$ to $Z = Z_f$ (in this case in the depth interval between $Z = 0$ and $Z = Z_i$ there will be no profile). However a desirable option is the possibility of having the diagrams plotted starting from a specified depth Z_0 below ground level.

6.5.5 Program No. 5 (prints a "catalogue" of the soundings on the tape.
E.g. HP "LISTA" program)

This program does the following:

- 6.5.5.1 Reads from the tape, starting from the address (registration number) specified by the operator, the main headlines or titles characterizing the sounding recorded at that address.
- 6.5.5.2 Prints on paper the address (registration number) and the information listed in 6.4.5.1.
- 6.5.5.3 Advances the tape to the next address and starts again as in 6.4.5.1, up to the last sounding on the tape or to a second address specified by the operator.

The printout is an up to date catalogue of the correspondence between registration numbers and soundings.

6.6 BIBLIOGRAPHY

- 1975 Marchetti, S., "A New In Situ Test for the Measurement of Horizontal Soil Deformability," Proceedings Conference on In Situ Measurement of Soil Properties, ASCE Specialty Conference, Raleigh, N.C., Vol. 2, June, 1975, pp. 255-259.
- 1977 Marchetti, S., "Devices for in situ determination of Soil Modulus E_s ," Specialty Session N.10, IX International Conf. on Soil Mech. and Found. Engineering, Tokyo, July 1977.
- 1979 Marchetti, S., "The In Situ Determination of an "Extended" Overconsolidation Ratio," Proceedings, 7th European Conference on Soil Mechanics and Foundation Engineering, Vol. 2, Sept., 1979, Brighton, England, pp. 239-244.
- 1979 Marchetti, S., "Determination of Design Parameters of Sands by means of Quasi-Statically Pushed Probes," Proceedings, 7th European Conference on Soil Mechanics and Foundation Engineering, Panel Presentation, Main Session C, Sept., 1979, Brighton, England.
- 1979 Bellotti, R., Bizzi, G., Ghionna, V., Jamiolkowski, M., Marchetti, S., and Pasqualini, E., "Preliminary Calibration Tests of Electrical Cone and Flat Dilatometer in Sand," Proceedings, 7th European Conference on Soil Mechanics and Foundation Engineering, Vol. 2, Sept., 1979, Brighton, England, pp. 195-200.
- 1979 Marchetti S., "Stress History of Clay Deposits", Proceedings, 7th European Conference on Soil Mechanics and Foundation Engineering, Discussion Session 4: Design Parameters for Stiff Clays, Discussion Vol., Sept., 1979, Brighton, England, pp. 143-145.
- 1979 Marchetti S., "On the Determination of In Situ K_0 in Sand", Proceedings, 7th European Conference on Soil Mechanics and Foundation Engineering, Discussion Session 7: Design Parameters for Sands, Discussion Vol., Sept., 1979, Brighton, England.
- 1979 Szabo G., "In situ Talajvizsgálatok Lapdilatometerrel" Melyepítéstudományi Szemle, Különlenyomat 1979 Evfolyam 5 Szamból, Budapest. (In Hungarian).
- 1980 Marchetti, S., "In Situ Tests by Flat Dilatometer", Journal of the Geotechnical Engineering Division, ASCE, Vol. 106, No. GT3, Proc. Paper 15290, Mar. 1980, pp. 299-321.
- 1980 Marchetti, S., "In Situ Tests by Flat Dilatometer", Presentation Annual Meeting, ASCE North Florida Section at Clearwater Beach, Sept. 12, 1980 (unpublished report).
- 1981 Schmertmann, J., discussion of "In Situ Tests by Flat Dilatometer", Journal of the Geotechnical Engineering Division, ASCE Vol. 107, No. GT6, Proc. Paper 15290, Jun 1980.
- 1981 Marchetti, S., Closure of "In Situ Tests by Flat Dilatometer", Journal of the Geotechnical Engineering Division, ASCE, Vol. 107, No. GT6, Proc. Paper 15290, Jun 1980.
- 1981 D'Antonio, V., "Soil Investigations and Stability Analysis of Gravity Quaywalls" (In Italian), to be published in the Giornale del Genio Civile, Consiglio Superiore dei Lavori Pubblici, Roma, 1981.
- 1981 Marchetti, S., and Panone, C., "Distorsions Induced in Sands by Probes of different Shapes" (In Italian), to be published in the Rivista Italiana di Geotecnica, Vol. 15, 1981.
- 1981 Marchetti, S., "Hewlett Packard System 9845B Computer Program to Reduce Dilatometer Data with Plotter Routines", Internal Report.
- 1981 Crapps, D. and Schmertmann, G., "DILLY", Fortran Computer Program to Reduce Dilatometer Data, Schmertmann & Crapps, Inc., Internal Report, Gainesville, Fla.
- 1981 Schmertmann, J.H., "D", Hewlett Packard Model 41C Computer Program to Reduce Dilatometer Data, Schmertmann & Crapps, Inc., Internal Report, Gainesville, Fla.
- 1981 GPE, Marchetti, S., "Outline of An Investigation To Establish Correlations Between Dilatometer Results and ϕ' in Sands", Internal Report, Gainesville, Fla.
- 1981 Boghrat, A. and Marchetti, S., "Preliminary Report on Development of a Piezoblade: Design and Construction", University of Florida, Department of Civil Engineering, Gainesville, Fla.