

THEME SECTION

Marine biodiversity: current understanding and future research

Idea: M. Solan

Coordination: M. Solan, P. van Avesaath, H. Hummel, C. H. R. Heip

Marine Ecology Progress Series Vol. 396, pages 165–306

CONTENTS

Solan M Introduction	166–168
De Voogd NJ, Becking LE, Cleary DFR Sponge community composition in the Derawan Islands, NE Kalimantan, Indonesia	169–180
Guidi-Guilvard LD, Thistle D, Khripounoff A, Gasparini S Dynamics of benthic copepods and other meiofauna in the benthic boundary layer of the deep NW Mediterranean Sea	181–195
Danovaro R, Bianchelli S, Gambi C, Mea M, Zeppilli D α -, β -, γ -, δ - and ϵ -diversity of deep-sea nematodes in canyons and open slopes of Northeast Atlantic and Mediterranean margins.....	197–209
Kochzius M, Seidel C, Hauschild J, Kirchhoff S, Mester P, Meyer-Wachsmuth I, Nuryanto A, Timm J Genetic population structures of the blue starfish <i>Linckia laevigata</i> and its gastropod ectoparasite <i>Thyca crystallina</i>	211–219
Christie H, Norderhaug KM, Fredriksen S Macrophytes as habitat for fauna	221–233
Blight AJ, Allcock AL, Maggs CA, Johnson M Intertidal molluscan and algal species richness around the UK coast	235–243
Hawkins SJ, Sugden HE, Mieszkowska N, Moore PJ, Poloczanska E, Leaper R, Herbert RJH, Genner MJ, Moschella PS, Thompson RC, Jenkins SR, Southward AJ, Burrows MT Consequences of climate-driven biodiversity changes for ecosystem functioning of North European rocky shores	245–259
Salo T, Gustafsson C, Boström C Effects of plant diversity on primary production and species interactions in brackish water angiosperm communities	261–272
Godbold JA, Solan M Relative importance of biodiversity and the abiotic environment in mediating an ecosystem process	273–282
Josefson AB Additive partitioning of estuarine benthic macroinvertebrate diversity across multiple spatial scales.....	283–292
Webb TJ, Tyler EHM, Somerfield PJ Life history mediates large-scale population ecology in marine benthic taxa	293–306



Introduction

Martin Solan^{1,*}

Oceanlab, University of Aberdeen, Main Street, Newburgh, Aberdeenshire, AB41 6AA, UK

ABSTRACT: Human activity extensively, and often irreversibly, alters marine biodiversity and ecosystems on a global scale. Notwithstanding a substantial research effort on the ecosystem consequences of altered biodiversity, it is vital that the marine community summarise and communicate its knowledge to policy makers. This Theme Section celebrates the establishment of the World Conference on Marine Biodiversity as a vehicle for integrating marine biodiversity science and co-ordinating future research efforts.

KEY WORDS: Biodiversity · Ecosystem functioning · Ecosystem processes · Macroecology · Spatial scale · Statistical partitioning

—Resale or republication not permitted without written consent of the publisher—

The status of global biodiversity fundamentally determines levels of ecosystem functioning and, ultimately, human well-being (see Naeem et al. 2009). Yet, the synergistic effects of multiple causes of biodiversity loss that is linked to human activities are causing serious threats to the functioning and viability of marine ecosystems (Halpern et al. 2008, Rockström et al. 2009). In Europe, the general consensus that marine systems are at significant risk led to the development of the Marine Biodiversity and Ecosystem Functioning Network of Excellence (MarBEF; www.marbef.org/) and the establishment of the first World Conference on Marine Biodiversity, held in Valencia, Spain during November 2008 (for reviews, see Webb 2009, Miloslavich & Klein 2009). At this meeting, a consensus on the current position of marine biodiversity research was agreed upon, based on contributions involving >1000 marine scientists and formulated as the Valencia Declaration (Box 1).

This Theme Section celebrates the establishment of this conference as the vehicle for integrating marine biodiversity science and co-ordinating future research efforts. It starts with contributions which document the spatial and temporal extent of particular species (de Voogd et al. 2009, Guidi-Guilvard et al. 2009, Danovaro et al. 2009), reminding us that little is known about the distribution of many species and highlighting the need for maintaining taxonomic expertise. Kochzius et al. (2009) uses comparative analyses of the

genetic population structure of a starfish and its associated parasite in order to establish which evolutionary and ecological processes led to the realised distribution of these and other species across the Indo-Malay Archipelago. Next, Christie et al. (2009) use data compiled from a number of sources to examine the role of macrophytes as habitat for other fauna and highlight how the presence of some species are important for the persistence of others. The documentation of change in species distributions in existing (Blight et al. 2009) and future (Hawkins et al. 2009) environments is essential for understanding how climate change affects marine communities, as are experimental manipulations of model communities in the laboratory and field for establishing the importance of biodiversity for ecosystem functioning (Salo et al. 2009). These concepts are extended to account for the role of other components of natural systems that influence ecosystem properties: Godbold & Solan (2009) use statistical partitioning to distinguish the relative importance of biodiversity and environmental variables along a gradient of organic enrichment for an important ecosystem process, whilst Josefson (2009) uses similar methodology to examine how diversity and environmental parameters change across spatial scales that extend to the km level. Finally, Webb et al. (2009) introduce the use of a macroecological framework for understanding how local and regional scale processes interact and how species traits may influence large scale patterns in diversity.

*Email: m.solan@abdn.ac.uk

Box 1. The Valencia Declaration: a plea for the protection of marine biodiversity (MarBEF; www.marbef.org/worldconference/docs/The_Valencia_Declaration_20081115.pdf)

Recognising the fundamental importance of marine biodiversity to human well-being,

Concerned that the convergence of global environmental pressures pose critical threats to the sustainability of marine biodiversity in the oceans,

Acknowledging efforts by many agencies to give increased attention to marine biodiversity, but aware that the current pace of efforts to protect marine biodiversity is insufficient,

We, the community of scientists engaged in research relevant to marine biodiversity and ecosystem functioning and ocean management gathered in the City of Arts and Sciences of Valencia, Spain at the World Conference on Marine Biodiversity, November 2008 agree, on the basis of the overwhelming scientific evidence presented, that:

- Marine biodiversity and ecosystems are essential to the functioning of our biosphere and hence to human well-being.

- The pace and scale of anthropogenic changes occurring in the oceans and the impact of these changes on marine biodiversity and ecosystems are cause for grave concern.

- When effectively designed, managed and enforced, marine protected areas can deliver many ecological and socio-economic benefits as well as building the resilience of marine ecosystems in the face of increasing global pressures

- Emerging human activities, such as geo-engineering of the oceans to mitigate climate change, may deliver negative impacts to marine ecosystems.

- Research efforts to explore marine biodiversity and assess its status are insufficient, lagging well behind similar effort on terrestrial biodiversity.

- To be effective, networks of marine protected areas must be ecologically coherent and should be embedded in integrated ocean management frameworks that address the range of human activities and impacts both within and beyond the protected areas.

- Deep sea ecosystems differ significantly from coastal ones such that the dynamics of most deep-sea fish stocks are so fragile and slow to recover that they should be approached with an exceptionally high degree of precaution.

We urge that:

- Integrated ocean management be put in place covering human activities impacting on marine biodiversity and ecosystems both within and beyond national jurisdiction.

- Ecologically coherent networks of marine protected areas be developed at an urgent and accelerated pace based on existing scientific data and understanding.

- Participative management structures be developed, where they do not exist, engaging those involved in the exploitation of marine living resources with the goal of sustainable use of marine biodiversity.

- Research efforts to explore and better understand marine biodiversity be enhanced and promoted to provide the knowledge base necessary to underpin an adaptive management process.

- Mechanisms be established to enhance cooperation between scientists, governments and relevant organizations to identify and protect ecologically and biologically significant areas based on the scientific criteria adopted by the Parties to the Convention on Biological Diversity for the open ocean and deep seas.

- Deep-sea fisheries be authorised only where evidence has been gathered to conclusively demonstrate that a stock can be sustainably exploited in full compliance with FAO Technical Guidelines for deep-sea fishing in the high seas.

- The United Nations General Assembly builds on the Law of the Sea and the Convention of Biological Diversity to achieve an international governance regime for the effective stewardship of marine areas beyond national jurisdiction and the fair and equitable use of living resources for the benefit of human kind.

Looking to the future, it is clear that impending environmental problems, often of considerable magnitude and complexity, require a portfolio of information from a variety of disciplines (Benton et al. 2007). It is also essential, however, that the marine community communicates knowledge as it accrues, even when it is incomplete or the advice is uncertain (Solan et al. 2009). For a variety of cultural reasons (Raffaelli et al. 2005), discussions with policy makers and the public have been dominated by terrestrial ecologists; the influence of the marine scientific community on environmental policy is comparatively poor (Hendriks et al. 2006). A commitment to an intergovernmental science-policy platform on biodiversity and ecosystem services

(<http://ipbes.net/>) is yet to be fully embraced by scientists and policymakers alike (Loreau et al. 2006, Mooney & Mace 2009), but such a consultation is necessary to ensure that efforts to sustain biodiversity do not continue to fall short of targets (Walpole et al. 2009) and that marine systems are appropriately protected. An immediate challenge for the marine community is to provide a policy-relevant consensus of opinion that is based on the latest portfolio of evidence, which recognises and incorporates levels of uncertainty. The 2nd World Conference on Marine Biodiversity (www.abdn.ac.uk/marine-biodiversity/), scheduled for September 2011, provides the next opportunity and platform to do so.

LITERATURE CITED

- Benton TG, Solan M, Travis J, Sait SM (2007) Microcosm experiments can inform global ecological problems. *Trends Ecol Evol* 22:516–521
- Blight AJ, Allcock AL, Maggs CA, Johnson M (2009) Intertidal molluscan and algal species richness around the UK coast. *Mar Ecol Prog Ser* 396:235–243
- Christie H, Norderhaug KM, Fredriksen S (2009) Macrophytes as habitat for fauna. *Mar Ecol Prog Ser* 396:221–233
- Danovaro R, Bianchelli S, Gambi C, Mea M, Zeppilli D (2009) α -, β -, γ -, δ - and ε -diversity of deep-sea nematodes in canyons and open slopes of Northeast Atlantic and Mediterranean margins. *Mar Ecol Prog Ser* 396:197–209
- de Voogd NJ, Becking LE, Cleary DFR (2009) Sponge community composition in the Derawan Islands, NE Kalimantan, Indonesia. *Mar Ecol Prog Ser* 396:169–180
- Godbold JA, Solan M (2009) Relative importance of biodiversity and the abiotic environment in mediating an ecosystem process. *Mar Ecol Prog Ser* 396:273–282
- Guidi-Guilvard LD, Thistle D, Khrpounoff A, Gasparini S (2009) Dynamics of benthic copepods and other meiofauna in the benthic boundary layer of the deep NW Mediterranean Sea. *Mar Ecol Prog Ser* 396:181–195
- Halpern BS, Walbridge S, Selkoe KA, Kappel CV and others (2008) A global map of human impact on marine ecosystems. *Science* 319:948–952
- Hawkins SJ, Sugden HE, Mieszkowska N, Moore PJ and others (2009) Consequences of climate-driven biodiversity changes for ecosystem functioning of North European rocky shores. *Mar Ecol Prog Ser* 396:245–259
- Hendriks IE, Duarte CM, Heip CHR (2006) Biodiversity research still grounded. *Science* 312:1715
- Josefson AB (2009) Additive partitioning of estuarine benthic macroinvertebrate diversity across multiple spatial scales. *Mar Ecol Prog Ser* 396:283–292
- Kochzius M, Seidel C, Hauschild J, Kirchhoff S, Mester P, Meyer-Wachsmuth I, Nuryanto A, Timm J (2009) Genetic population structures of the blue starfish *Linckia laevigata* and its gastropod ectoparasite *Thyca crystallina*. *Mar Ecol Prog Ser* 396:211–2219
- Loreau M, Oteng-Yeboah A, Arroyo MTK, Babin D and others (2006) Diversity without representation. *Nature* 442:245–246
- Miloslavich P, Klein E (2009) The World Conference on Marine Biodiversity: current global trends in marine biodiversity research. *Mar Biodiv* 39:147–152
- Mooney H, Mace G (2009) Biodiversity policy challenges. *Science* 325:1474
- Naeem S, Bunker DE, Hector A, Loreau M, Perrings C (2009) Biodiversity, ecosystem functioning and human wellbeing: an ecological and economic perspective. Oxford University Press
- Raffaelli D, Solan M, Webb TJ (2005) Do marine ecologists do it differently? *Mar Ecol Prog Ser* 304:283–289
- Rockström J, Steffen W, Noone K, Persson A and others (2009) A safe operating space for humanity. *Nature* 461:472–475
- Salo T, Gustafsson C, Boström C (2009) Effects of plant diversity on primary production and species interactions in brackish water angiosperm communities. *Mar Ecol Prog Ser* 396:261–272
- Solan M, Godbold JA, Symstad A, Flynn DFB, Bunker D (2009) Biodiversity-ecosystem function research and biodiversity futures: early bird catches the worm or a day late and a dollar short? In: Naeem S, Bunker DE, Hector A, Loreau M, Perrings C (eds) Biodiversity, ecosystem functioning and human wellbeing: an ecological and economic perspective. Oxford University Press, p 30–45
- Walpole M, Almond REA, Besancon C, Butchart SHM and others (2009) Tracking progress toward the 2010 biodiversity target and beyond. *Science* 325:1503–1504
- Webb TJ (2009) Biodiversity research sets sail: showcasing the diversity of marine life. *Biol Lett* 5:145–147
- Webb TJ, Tyler EHM, Somerfield PJ (2009) Life history mediates large-scale population ecology in marine benthic taxa. *Mar Ecol Prog Ser* 396:293–306



Sponge community composition in the Derawan Islands, NE Kalimantan, Indonesia

Nicole J. de Voogd^{1,*}, Leontine E. Becking¹, Daniel F. R. Cleary²

¹National Museum of Natural History, PO Box 9517, 2300 RA Leiden, The Netherlands

²Departamento de Biologia, Centro de Estudos do Ambiente e do Mar (CESAM), Universidade de Aveiro, Campus Universitário de Santiago, 3810-193 Aveiro, Portugal

ABSTRACT: Coral reef ecosystems in Indonesia are among the most diverse in the world. Conservation, restoration and management of marine biodiversity hotspots such as Indonesia's coral reefs require accurate baseline knowledge of the constituent species and the environmental conditions under which these species thrive. Here we present a study on the habitat structure and diversity, composition and abundance of reef sponges in the Derawan Islands, East Kalimantan, Indonesia. Mean live coral cover across depths and sites was just under 30%, while the mean cover of rubble and dead coral exceeded 40%. The distribution of live coral cover was patchy; the inshore sites had the lowest cover, while some offshore sites also had very low coral cover due to the effects of blast fishing. Rubble cover was highest inshore and beyond the barrier reef, whereas dead coral was most abundant in shallow-water and midshore reefs. A total of 168 sponge species or morphospecies were identified, of which *Stelletta clavosa*, *Lamellodysidea herbacea*, *Niphates* sp., *Ircinia ramosa* and *Petrosia nigricans* were the most common. Sponge composition varied in relation to distance from the Berau River and water visibility, in addition to sand cover and cover of encrusting corals. Importantly, sponges in the Derawan Islands appeared to thrive in inshore reefs that already had depauperate coral communities. This is in marked contrast to findings elsewhere in Indonesia (NW Java, SW Sulawesi) where inshore communities were depauperate for all taxa sampled.

KEY WORDS: Sponges · Coral reefs · Marine diversity · East Kalimantan · Berau

Resale or republication not permitted without written consent of the publisher

INTRODUCTION

The coral reefs of Indonesia are among the most diverse, but also most threatened reefs in the world. Proper conservation and management of Indonesia's coral reefs requires accurate baseline studies of the constituent taxa and environmental conditions (Mora et al. 2003). The acquisition of spatially explicit environmental data is essential to understand how spatial and environmental processes (including human-induced disturbance) interact to structure marine assemblages.

Most reef surveys have tended to focus on charismatic groups such as corals or fishes and have generally taken place in areas which have already experienced massive biodiversity losses and shifts in composition as a result of historical disturbances. In the

Thousands Islands, NW Java, for example, historical coral collections were compared with recent reef surveys (van der Meij et al. 2009) and revealed that the diversity of corals has declined dramatically over a time span of only ca. 70 yr. Once diverse reefs close to the city of Jakarta had in fact virtually disappeared by 1995. Other studies, close to the city of Makassar (SW Sulawesi), reflected these findings in identifying a strong onshore–offshore gradient in composition with depauperate communities close to the city (Cleary et al. 2005, Becking et al. 2006). In addition to studying a wide array of coral reef taxa and using the limited historical data available to compare coral reef environments, it is also important to study the few remaining relatively undisturbed areas.

The Berau Delta and barrier reef system in East Kalimantan (Derawan Islands), Indonesia, is an intricate

*Email: voogd@naturalis.nnm.nl

coastal system with a variety of coastal landforms and associated ecosystems. The Berau River basin and delta is composed of 2 major estuaries and is surrounded by mangrove forest. At the delta-front there is a barrier reef system that extends to the offshore islands of Kakaban and Maratua with oceanic reefs that border the Makassar Strait (Tomascik et al. 1997). Although the coastal region is reported to still have a number of relatively pristine characteristics, fish and shrimp ponds are gradually replacing the natural coastal vegetation and offshore reefs are becoming increasingly damaged by destructive, albeit illegal, fishing techniques such as blast fishing (Estradivari 2008). Furthermore, the Derawan Islands are unique and of global interest due to the presence of several anchialine lakes located within the islands of Kakaban and Maratua (Tomascik et al. 1997, Becking & Lim 2009). In addition to the lakes, the Derawan chain contains one of Indonesia's largest nesting grounds of the endangered green sea turtle.

In the present study, we assessed the habitat structure (e.g. cover of branching coral, massive coral, sand or rubble), abiotic environmental variables (e.g. temperature, salinity, pH) and composition and abundance of larger reef sponges. Sponges have often been left out of biodiversity surveys because of difficulties in identifying taxa, even at higher taxonomic levels. They are, however, an important coral reef benthic group, and play a key role in nutrient cycling, water filtering, bioerosion, reef stabilization, spatial competition and as habitat for other reef invertebrates (Aerts & van Soest 1997, Skilleter et al. 2005, Wulff 2006, Bell 2008). The loss of sponge species could accelerate declines in coral reefs as they are fundamental in increasing water clarity, binding live corals to the reef frame and facilitating reef regeneration (Wulff 2006, Bell 2008). The aims of the present study were to (1) assess to what extent the reefs of the Derawan Islands are undisturbed by quantifying the area of live coral cover and other structural components, including coral rubble and dead coral; (2) quantify spatial variation in sponge composition, abundance and species richness across a large spatial scale; and (3) quantify to what extent variation in composition can be explained by abiotic environmental variables, habitat structure variables or purely spatial variables.

MATERIALS AND METHODS

Study area. Research for the present study took place in the Derawan Islands, NE Kalimantan, Indonesia. Coral reefs in this area are found across a water gradient from fluvially influenced to fully oceanic, separated by a barrier reef. The reefs inside the barrier reef are

under direct influence of the Berau River, and the river plume can extend 15 to 30 km from the mainland during the rainy season. The depth of the coral reefs inside the barrier reef varies from 10 m close to the river mouth to more than 150 m close to the barrier. Inshore reefs have a relatively low coral cover, with high densities of filter feeders such as sponges, soft corals and crinoids, and the rubble is covered by fine mud and silt (Renema 2006a). The outside barrier is comprised of diverse reef types, dominated by dense stands of corals and coarse sand. Annual precipitation averages 2400 mm with no clear rainy season.

Sponges. Sampling took place using SCUBA diving from 10 to 23 August 2008. Surveys were made at 2 depths (5 and 10 m) at 18 different sites (Fig. 1, Table 1). Sponge species and their abundance were noted in 1 m² quadrats laid every 1 m along a 30 m line-transect. Smaller (cryptic, boring and thinly encrusting) sponge specimens were excluded from the present study. Species were visually identified in the field, and fragments of all species were collected for closer examination and identification to species level by N. J. de Voogd. Voucher specimens were preserved in 70% ethyl alcohol and deposited in the sponge collection of The National Museum of Natural History, 'Naturalis' (RMNH Porifera).

Environmental variables. Vertical water visibility, temperature, pH, salinity and depth were assessed as local abiotic environmental variables. Vertical water visibility was measured using a Secchi disc following English et al. (1997) at around 12:00 h near the surveyed sites. Depth was measured using a computerized depth meter (Suunto). Geographic coordinates were recorded at each transect with a handheld GPS device (Garmin GPS 60). Temperature, salinity and pH were measured in duplicate per site with an YSI Model 63 handheld pH, conductivity, salinity and temperature system. In addition to these variables, we also include the distance of each site to the mouth of the Berau River. We assumed this was a proxy of processes including sedimentation and land-based contamination, as the Berau River is the main conduit of these factors into the research area.

Habitat structure. The habitat structure was assessed using the line intercept transect (LIT) method for surveys (English et al. 1997, Edinger & Risk 2000). In the present study, the cover of 28 life forms (see English et al. 1994) was assessed along two 30 m line transects located at 5 and 10 m depth in each site. The life forms (including non-living substrate) were hard dead coral (dead coral, dead coral with algae), *Acropora* corals (branching, encrusting, submassive, digitate, tabular), non-*Acropora* corals (branching, encrusting, foliose, massive, submassive, mushroom, *Heliopora*, *Millepora*, *Tubipora*); other fauna (soft corals, sponges, zoanthids

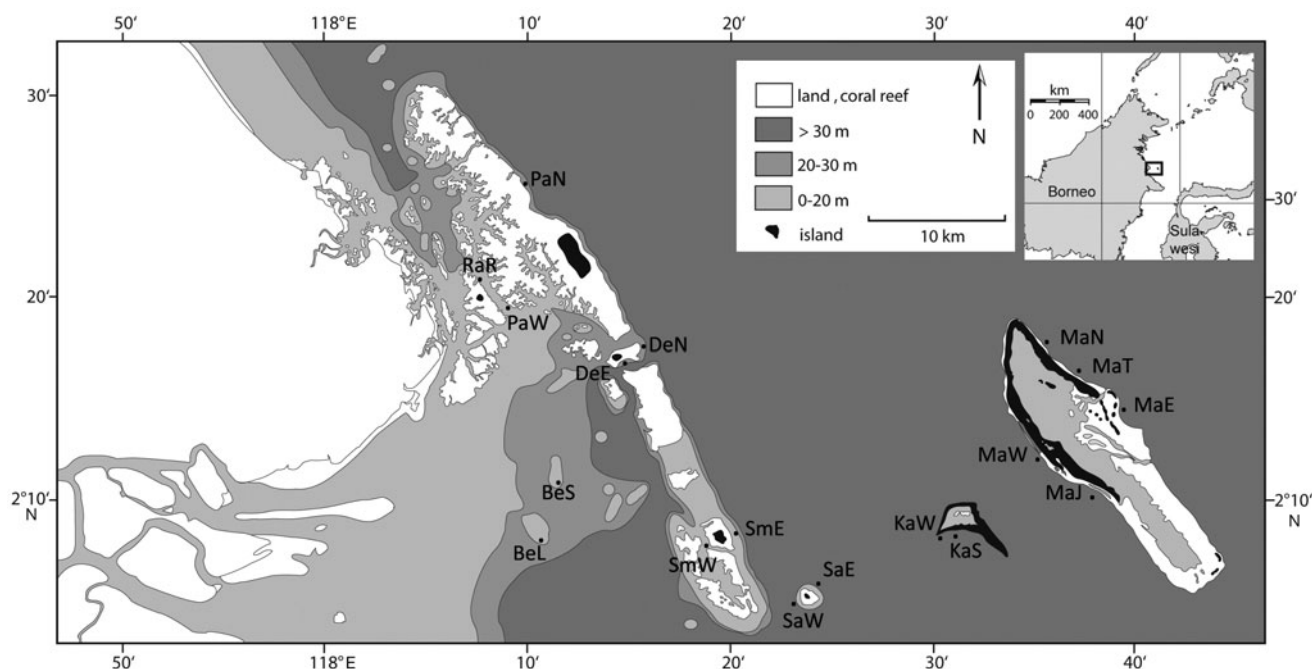

Fig. 1. Derawan Islands, East Kalimantan, Indonesia. BeL: Berau 'Lighthouse'; BeS: Berau South; DeE: Derawan 'Jetty Point'; DeN: Derawan 'Coral Garden'; KaS: Kakaban Southwest; KaW: Kakaban West; MaN: Maratua Northwest; MaE: Maratua 'Midnight Snapper'; MaW: Maratua 'Traffic'; MaT: Maratua 'Parade'; MaJ: Maratua 'Johnny's Reef'; PaW: Panjang West; PaN: Panjang Northeast; RaR: Rabu Rabu; SmE: Samama East; SmW: Samama West; SaE: Sangalaki East; SaW: Sangalaki West. Map adapted from Renema (2006a) with permission

and other invertebrate taxa); algae (algal assemblages, coralline algae, *Halimeda*, macroalgae, turf algae); and abiotic (sand, rubble, rock). The LIT method was used to estimate the cover of a life form and non-living substrate, in this case along a 30 m transect. The cover or percentage was calculated by the fraction of the length of the line that was intercepted by the life form in question.

Analytical framework. All analyses were performed and figures were made using R (www.r-project.org). For rarefaction and estimation of species richness using the Chao1 and Chao2 richness estimators, we used the *vegan* and *fossil* packages, respectively. Two ordination techniques were used to analyse the species: environmental and spatial data matrices. Principal components analysis (PCA) was used as an unconstrained ordination technique to explore the major axes of variation in the species \times sites data matrix. Redundancy analysis (RDA) was used as a constrained ordination technique to relate sponge species to environmental variables (Legendre & Gallagher 2001). Input for the PCA and RDA consisted of $\log_e(x+1)$ species abundance data that were first transformed using the *decostand* function in the *vegan* package. Through this transformation, the species abundance data were adjusted so that the PCA and RDA preserved the chosen distance among objects (sample sites). In the present case, the Hellinger distance was

used, as recommended by Legendre & Gallagher (2001).

Spatial variation in the study area was modelled using principal coordinates of neighbour matrices (PCNM). PCNM is a novel method for quantifying spatial trends across a range of scales and is based on eigenvalue decomposition of a truncated matrix of geographic distances among sampling sites (Borcard & Legendre 2002). For a detailed description of PCNM, see Borcard & Legendre (2002) and Dray et al. (2006). Significant PCNM eigenvectors were selected using the *quickPCNM* function with 999 permutations. Significant environmental and habitat structure variables were selected using the *forward.sel* function in the *packfor* package with 999 permutations. (Both *quickPCNM* in the *PCNM* library and *packfor* are available at the website of Pierre Legendre, www.bio.umontreal.ca/legendre/indexEn.html). The forward selection test used was based on a novel forward selection procedure that corrects for the inflated Type I error and overestimation of explained variance associated with classical forward selection (Blanchet et al. 2008). All significant PCNM, environmental and spatial variables were used in an RDA using the *rdaTest* function (www.bio.umontreal.ca/legendre/indexEn.html). Finally, we used variance partitioning (with the *varpart* function in *vegan*) to partition the variance explained by spatial, environmental and habitat structure variables.

Table 1. Characteristics of all transects sampled during the course of this study. Distance river: distance from the mouth of the River Berau, Lat: latitude in decimal degrees, Long: longitude in decimal degrees. Abundance: number of individual sponges sampled, Richness: rarefied number of species observed based on the minimum number of individuals sampled on a transect (n = 35). Life form data representing the percentage cover of coralline algae, turf algae, dead corals, rubble, sand, sponges and all live corals combined are also presented

Site code	Location	Depth (m)	Visibility (m)	pH	Temperature (°C)	Salinity (ppt)	Distance river (km)	Lat (°N)	Long (°E)	Abundance	Richness	Coralline algae (%)	Turf algae (%)	Dead coral (%)	Rubble (%)	Sand (%)	Sponge (%)	Total coral (%)
BeL	Berau	5	6.5	8.24	28.8	33	9.66	2.16	118.17	161	14.79	0.00	3.00	6.00	5.33	8.00	16.00	25.67
BeL	'Lighthouse'	10	6.5	8.21	28.9	33.55	9.66	2.16	118.17	231	18.29	1.17	0.50	0.00	38.50	7.17	16.33	4.50
RaR	Rabu-Rabu	5	7.5	8.25	28.85	33.8	11.02	2.35	118.13	163	19.48	0.00	2.00	9.67	24.33	9.00	9.67	34.67
RaR		10	7.5	8.215	28.9	33.8	11.02	2.35	118.13	205	21.05	1.50	8.00	5.67	33.50	10.83	3.50	30.00
BeS	Berau 'South'	5	8	8.24	28.95	32.95	12.43	2.20	118.19	321	18.54	1.00	0.33	5.70	19.50	17.00	12.47	22.67
BeS		10	8	8.195	28.85	33.35	12.43	2.20	118.19	270	13.13	2.67	0.00	1.83	11.00	10.33	10.63	53.37
PaW	West Panjang	5	11	8.235	28.75	33.6	13.86	2.33	118.18	224	15.54	0.00	0.00	8.33	18.00	9.00	11.50	41.00
PaW		10	11	8.18	28.6	33.6	13.86	2.33	118.18	141	20.85	0.00	0.67	1.00	57.00	7.33	3.17	22.83
PaN	NE Panjang	5	21	8.285	28.9	33.95	16.66	2.43	118.16	100	14.60	4.97	0.00	10.47	47.67	4.27	1.27	23.73
PaN		10	21	8.255	28.95	33.9	16.66	2.43	118.16	283	15.52	3.27	2.27	4.10	36.60	2.60	6.27	16.17
DeE	Derawan	5	21.5	8.29	28.6	34	19.40	2.28	118.25	106	15.45	0.00	0.00	19.33	54.33	11.17	0.67	9.00
DeE	'Jetty Point'	10	21.5	8.25	28.6	34	19.40	2.28	118.25	132	13.13	5.77	0.20	12.70	33.10	17.50	2.40	27.33
DeN	Derawan	5	26	8.295	29.4	34.1	21.00	2.30	118.26	110	14.48	3.00	0.00	24.67	9.33	9.33	4.33	35.33
DeN	'Coral Garden'	10	26	8.26	28.9	34.05	21.00	2.30	118.26	312	18.41	8.20	0.00	17.67	16.33	3.00	3.80	33.50
SmW	W Samama	5	13	8.225	28.75	33.6	26.18	2.13	118.32	174	13.49	0.00	0.33	19.33	8.33	6.33	3.80	51.83
SmW		10	13	8.185	28.65	33.8	26.18	2.13	118.32	135	15.26	4.50	0.00	8.00	23.00	20.00	1.33	34.50
SmE	E Samama	5	24.5	8.26	28.85	33.9	28.86	2.13	118.34	122	16.40	2.33	1.83	11.17	11.77	1.33	0.17	33.17
SmE		10	24.5	8.21	28.8	33.75	28.86	2.13	118.34	211	15.23	1.17	0.17	10.17	25.90	32.00	4.33	14.50
SaW	W Sangalaki	5	25	8.23	28.65	34	34.49	2.09	118.39	58	14.35	0.00	0.67	52.33	19.00	0.33	0.00	23.50
SaW		10	25	8.195	28.7	34.05	34.49	2.09	118.39	140	10.81	1.67	2.67	47.00	10.33	10.00	3.67	20.00
SaE	E Sangalaki	5	28.5	8.26	28.7	33.15	35.89	2.09	118.40	101	14.63	0.00	0.00	63.33	6.67	0.00	2.33	20.33
SaE		10	28.5	8.21	28.75	34.1	35.89	2.09	118.40	187	16.47	3.17	1.00	23.17	15.33	2.67	5.33	36.00
KaS	SW Kakaban	5	41.5	8.25	28.45	34.15	47.11	2.14	118.51	117	18.63	1.80	0.00	16.47	16.17	0.00	4.23	54.27
KaS		10	41.5	8.205	28.25	34.05	47.11	2.14	118.51	444	19.62	11.53	0.00	4.50	14.60	0.00	17.90	34.40
KaW	W Kakaban	5	40	8.27	28.15	34.15	48.02	2.14	118.51	953	2.83	0.00	0.00	8.67	71.67	0.33	1.67	15.83
KaW		10	40	8.24	28.05	34.1	48.02	2.14	118.51	794	5.87	2.67	0.33	12.00	35.67	3.00	1.00	42.67
MaW	W Maratua	5	45.5	8.265	28.8	33.95	56.69	2.20	118.59	159	14.45	0.00	1.00	36.00	33.67	0.00	2.17	21.00
MaW	'Turtle traffic'	10	45.5	8.24	28.8	33.75	56.69	2.20	118.59	199	17.00	2.17	0.67	13.00	31.33	0.67	8.50	31.83
MaJ	SW Maratua	5	41	8.29	28.8	34	61.88	2.17	118.64	194	14.26	14.33	0.00	7.67	14.33	3.00	5.00	42.00
MaJ	'Johnny's Reef'	10	41	8.245	28.2	34.1	61.88	2.17	118.64	260	16.34	14.17	0.67	8.33	9.00	0.67	6.67	32.83
MaN	NE Maratua	5	42.5	8.245	28.9	33.65	56.87	2.29	118.59	114	13.03	1.67	2.00	38.00	26.67	0.00	0.33	29.67
MaN	'Macronesia'	10	42.5	8.225	28.9	33.45	56.87	2.29	118.59	259	16.60	4.33	1.67	6.00	32.00	0.67	3.33	27.67
MaT	E Maratua	5	46.5	8.295	29	33.9	60.57	2.26	118.63	35	14.00	1.33	4.67	13.67	13.00	0.00	3.67	55.67
MaT	'Turtle parade'	10	46.5	8.255	29	33.9	60.57	2.26	118.63	170	16.04	3.67	28.67	14.33	21.67	0.00	1.67	13.67
MaE	SE Maratua	5	27.5	8.225	29.3	33.6	63.63	2.24	118.65	65	6.11	1.00	5.00	22.00	48.00	2.00	0.00	7.67
MaE	'Midnight snapper'	10	27.5	8.22	29.05	33.65	63.63	2.24	118.65	160	13.45	5.00	8.33	19.33	23.67	4.00	5.00	19.17

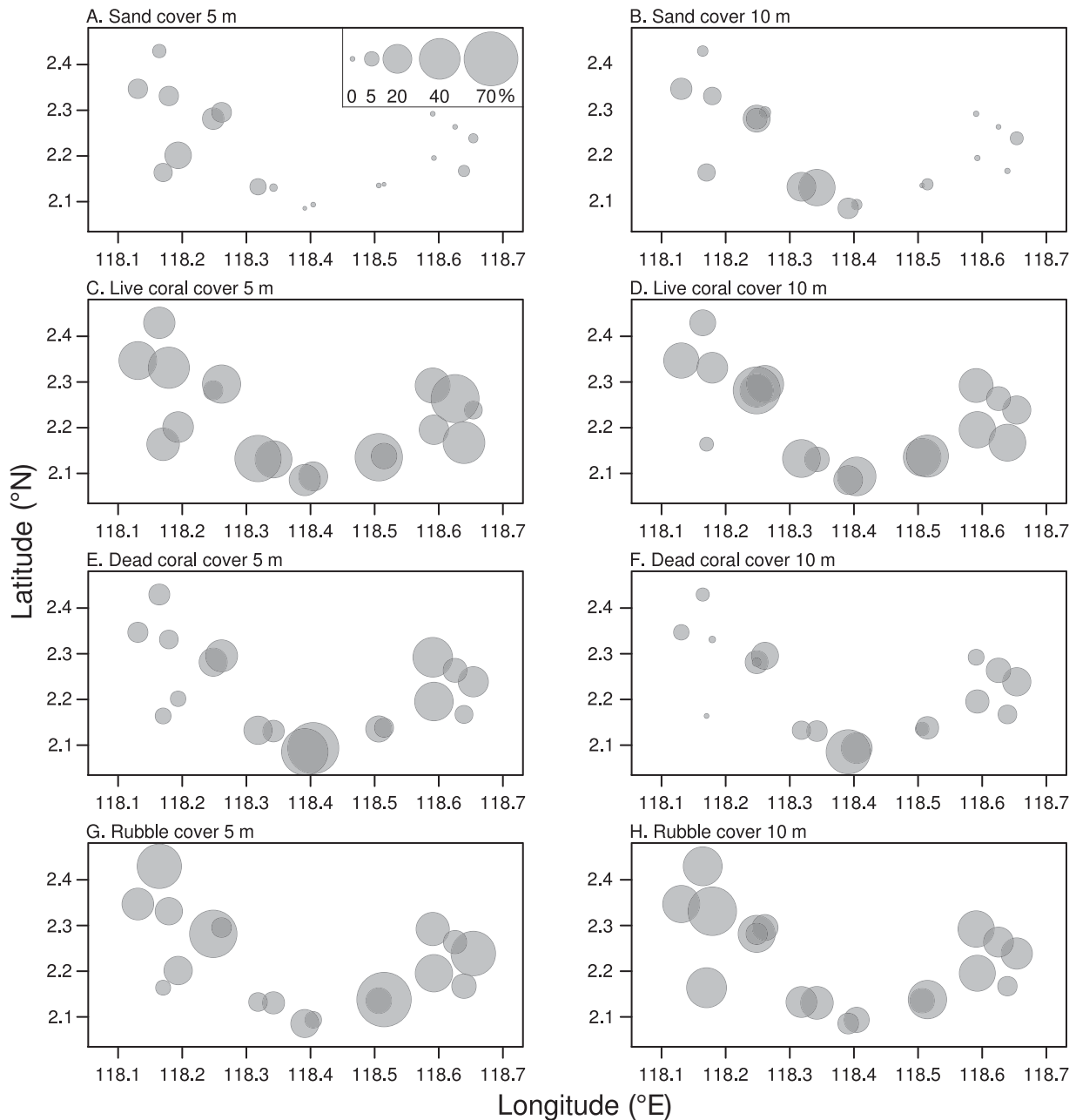

Fig. 2. Cover of sand, live coral cover, dead coral and rubble across the Derawan Islands. (A) Sand at 5 m (range = 0 to 17.0%), (B) sand at 10 m (0 to 32.0%), (C) live scleractinian coral at 5 m (7.7 to 55.7%), (D) live scleractinian coral at 10 m (4.5 to 54.4%), (E) dead coral at 5 m (5.7 to 63.3%), (F) dead coral at 10 m (0 to 19.3%), (G) rubble at 5 m (5.3 to 71.7%) and (H) rubble at 10 m (9 to 57%)

RESULTS

Live scleractinian coral cover ranged from 7.7 to 55.7% at 5 m and 5.7 to 63.3% at 10 m depth (Fig. 2, Table 1). Average live coral cover across sites and depths was 28.9%. The percentage cover of rubble was highest inshore and offshore and markedly less midshore, and across all sites ranged from 5.3 to 71.7% (at KaS; see Fig. 1 for site abbreviations) with a mean of

25.4%. Dead coral cover appeared to have quite a different pattern to rubble. Dead coral cover was higher midshore than inshore or offshore and was also somewhat higher at 5 than 10 m depth (Fig. 2). Overall, dead coral cover ranged from 0 to 63.3% with a mean of 16.1%. We sampled 7810 individual sponges and identified a total of 168 sponge species belonging to 62 genera and 37 families (see the complete species list in Table S1 in the electronic supplement at

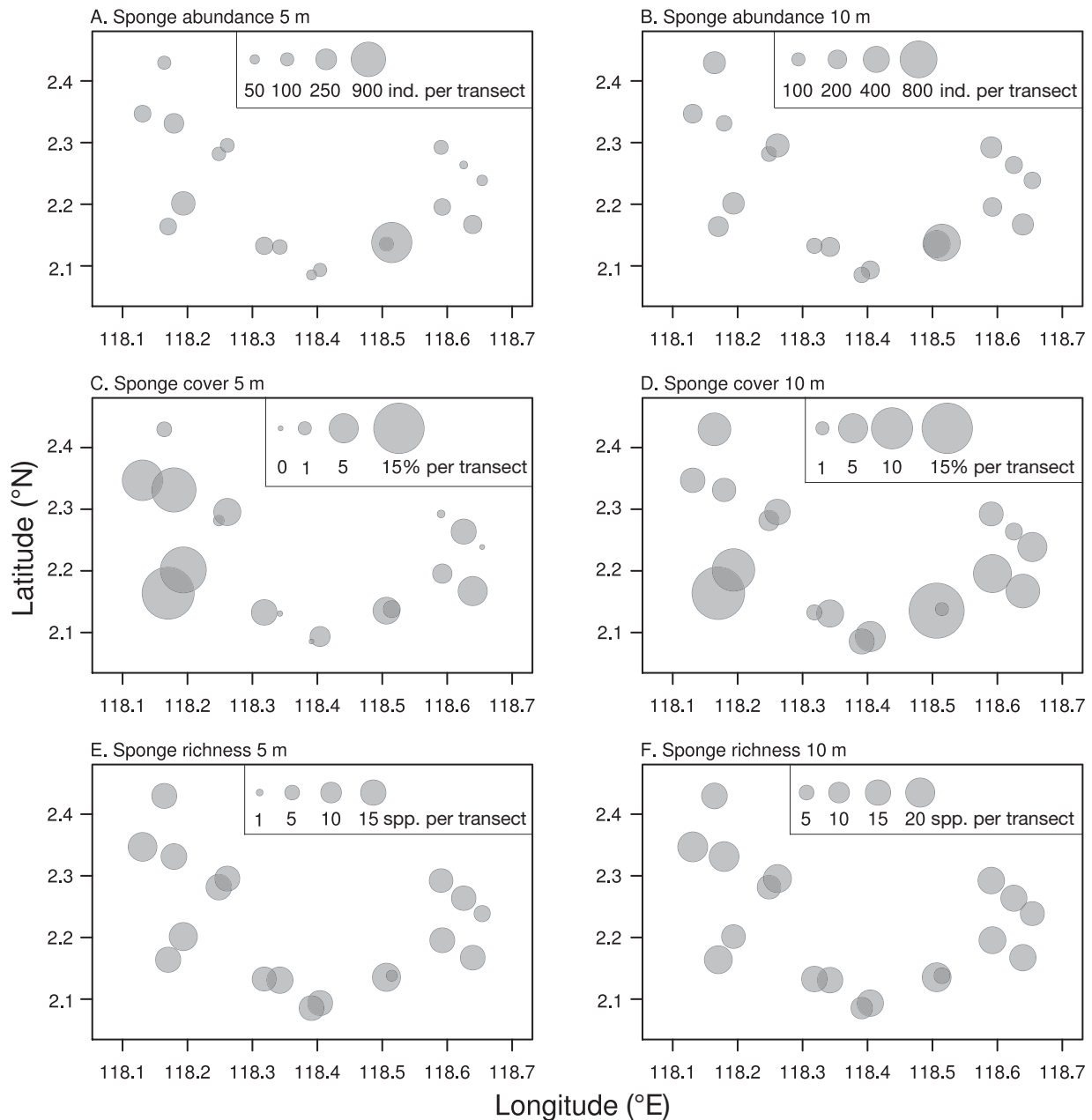

Fig. 3. Abundance, cover and species richness of sponges in the Derawan Islands. (A) Sponge abundance at 5 m (range = 35 to 953 individuals per transect) and (B) 10 m across sampling sites (132 to 794 individuals per transect). (C) Sponge cover as percentage of total cover at 5 m (range = 0 to 16% per transect) and (D) 10 m across sampling sites (1 to 17.9% per transect). (E) Sponge rarefied ($n = 35$ individuals) species richness at 5 m (range = 2.83 to 19.48 species per transect) and (F) 10 m across sampling sites (5.87 to 21.05 species per transect)

www.int-res.com/articles/suppl/m396p169_app.pdf). The median number of individuals recorded per transect was 119.5 (range = 35 to 953 individuals) at 5 m depth and 202 (range = 132 to 794 individuals) at 10 m depth (Fig. 3). Mean sponge cover varied from 4.40% (range = 0 to 16%) at 5 m depth to 5.37% (range = 1 to 17.9%) at 10 m depth. Rarefied species richness varied from 14.17 species (range = 2.83 to 19.48 species) at 5 m

depth to 15.73 species (range = 5.87 to 21.05 species) at 10 m depth (Fig. 3). Only 8 species were common (as defined by Kaandorp 1986), i.e. co-occurred in >23 different transects of the total of 36 transects (66% level of transects), namely *Carteriospongia foliascens*, *Cinachyrella* spp., *Clathria reinwardti*, *Hyrtios erectus*, *Ircinia ramosa*, *Lamellodysidea herbacea*, *Niphates* sp. 'blue' and *Petrosia nigricans*. The 10 most abundant species

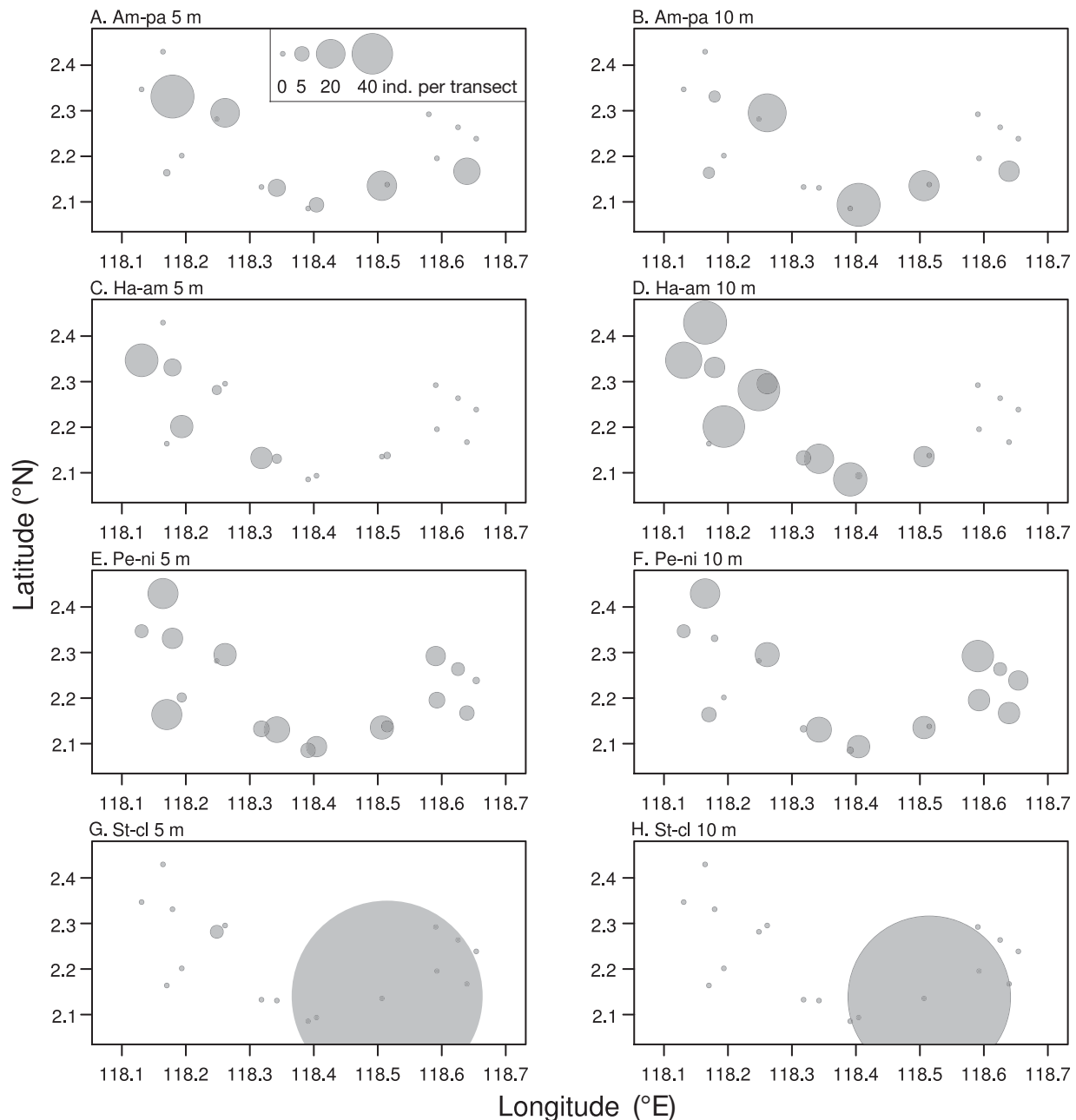

Fig. 4. Variation in the abundance of selected species across the Derawan Islands. (A) *Amphimedon paraviridis* (Am-pa) at 5 m (range = 0 to 45 individuals per transect) and (B) 10 m across sampling sites (range: 0 to 26 individuals per transect). (C) *Haliclona* aff. *amboinensis* (Ha-am) at 5 m (0 to 26 individuals per transect) and (D) 10 m across sampling sites (0 to 45 individuals per transect). (E) *Petrosia nigricans* (Pe-Ni) at 5 m (0 to 22 individuals per transect) and (F) 10 m across sampling sites (0 to 24 individuals per transect). (G) *Stelletta clavosa* (St-cl) at 5 m (0 to 891 individuals per transect) and (H) 10 m across sampling sites (0 to 645 individuals per transect)

sampled during the present study were *Amphimedon paraviridis* (234), *Clathria reinwardti* (237), *Carteriospongia foliascens* (250), *Hyrtios erectus* (254), *Haliclona* aff. *amboinensis* (280), *Petrosia nigricans* (298), *Niphates* sp. 'blue' (304), *I. ramosa* (327), *L. herbacea* (603) and *Stelletta clavosa* (1540). The distribution of 4 of these species is shown in Fig. 4. *Haliclona* aff.

amboinensis had a pronounced preference for inshore sites whereas *A. paraviridis* was more patchily distributed, although it attained high local abundance. The sponge *P. nigricans* was found in most sites in moderate densities. *Stelletta clavosa*, the most abundant species overall, was curiously enough only recorded in 3 transects. In one transect (DeE 5 m) only 4 individuals

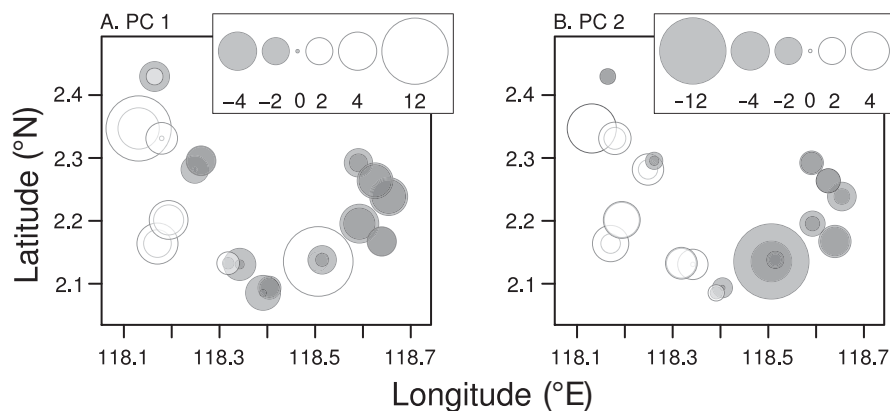

Fig. 5. Variation in site scores of (A) PC1 (range: -4.12 to 13.26) and (B) PC2 (-15.44 to 6.60). Open symbols indicate positive values and shaded symbols negative values. The size of the symbol is proportional to the score

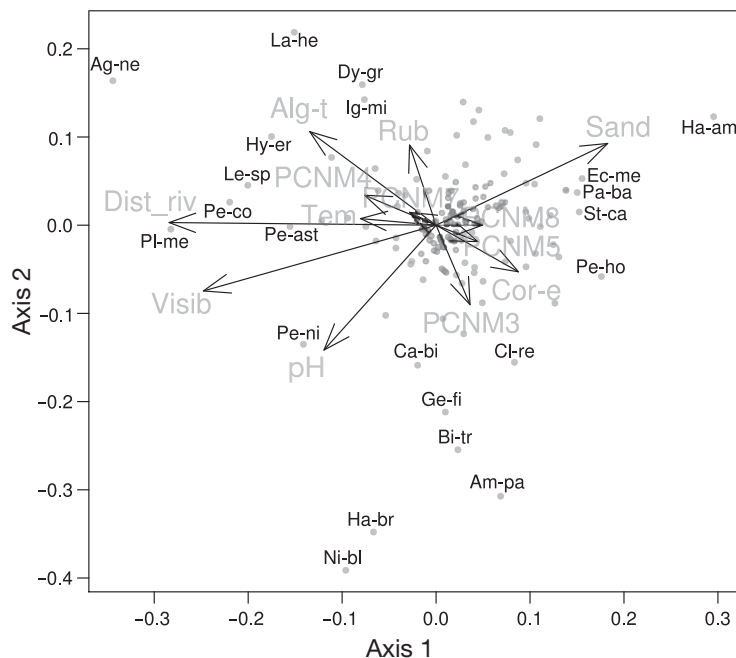

Fig. 6. Ordination of sponges based on redundancy analysis. Arrows represent significant spatial, habitat and environmental variables, and their direction and length indicates their contribution to variation along those axes. Significant variables include principal coordinates of neighbour matrices (PCNM) 3, 4, 5, 7 and 8, the cover of sand, encrusting corals (Cor-e), turf algae (Alg-t) and rubble (Rub), temperature (Tem), pH, water transparency/visibility (Visib) and the distance from the Berau River (Dist_riv). Species are indicated by dots; selected species are indicated by codes: Ag-ne: *Agelas* aff. *nemoechinata*; Am-pa: *Amphimedon paraviridis*; Bi-tr: *Biemna triraphis*; Ca-bi: *Callyspongia biru*; Cl-re: *Clathria reinwardti*; Dy-gr: *Dysidea granulosa*; Ec-me: *Echinodictyum mesenterinum*; Ge-fi: *Gelliodes fibulata*; Ha-am: *Haliclona* aff. *amboinensis*; Ha-br: *Haliclona* (*Soestella*) sp.; Hy-er: *Hyrtios erectus*; Ig-mi: *Igernella mirabilis*; La-he: *Lamellodysidea herbacea*; Le-sp: *Lendenfeldia* sp.; Ni-bl: *Niphates* sp.; Pa-ba: *Paratetilla* aff. *bacca*; Pe-ast: *Petrosia* aff. *strongylata*; Pe-co: *Petrosia corticata*; Pe-ho: *Petrosia hoeksemai*; Pe-ni: *Petrosia nigricans*; Pl-me: *Placospongia melobesioidea*; St-ca: *Stelletta clavosa*

were recorded, whereas 645 to 891 individuals were recorded in the other 2 transects (KaW 5 m and KaW 10 m).

Species composition, based on the first 2 axes of a PCA, showed a largely inshore–offshore gradient in composition along the first (8.69% of total variation explained) and second axes (7.59% of total variation explained) (Fig. 5). The most distinct sponge assemblages were found at sites RaR 10 m (score on PC1 = 11.63) and KaS 10 m (score on PC1 = 13.28; PC2 = -15.44). Both sites had a number of species that were not recorded in any other transect (5 for RaR 10 m and 6 for KaS 10 m). One species, *Axinyssa* sp. '118', was represented by 9 individuals at KaS 10 m. In total, 38 species were only recorded at a single transect, indicating that actual diversity was higher than recorded. In addition, a total of 26 singletons and 11 duplicates were recorded at the study area. Estimates using the Chao1 and Chao2 richness estimators both yielded an expected lower bound richness of 198 species compared to the 168 species we observed.

There was a significant relationship between space and community composition. Using a forward selection procedure, 5 PCNM variables were selected out of a total of 11. Significant PCNM variables are shown in Fig. S1 in the supplement. The same technique yielded 4 significant environmental variables and 4 significant habitat structure variables. Significant environmental variables included the distance from the river ($F = 3.259$, $p < 0.001$, $R^2_{adj} = 0.061$), water transparency/visibility ($F = 1.925$, $p = 0.002$, $R^2_{adj} = 0.025$), tempera-

ture ($F = 1.855$, $p = 0.002$, $R^2_{\text{adj}} = 0.023$) and pH ($F = 1.447$, $p = 0.028$, $R^2_{\text{adj}} = 0.012$). The variation in visibility is shown in Fig. S1 in the supplement, revealing an increase in visibility away from the river. Significant habitat structure variables included cover of sand ($F = 2.135$, $p < 0.001$, $R^2_{\text{adj}} = 0.031$), encrusting coral ($F = 1.643$, $p = 0.007$, $R^2_{\text{adj}} = 0.018$), turf algae ($F = 1.549$, $p = 0.011$, $R^2_{\text{adj}} = 0.016$) and rubble ($F = 1.372$, $p = 0.050$, $R^2_{\text{adj}} = 0.011$).

The spatial variation in community composition in relation to environmental variables is shown in Fig. 6. There was a highly significant relationship between the set of spatial, environmental and habitat structure variables and community composition ($F = 1.916$, $p < 0.001$, $R^2 = 0.531$, $R^2_{\text{adj}} = 0.254$). Space, environment and habitat structure together thus explained more than 25% of the variation in composition. Space, environment and habitat structure alone explained 9, 10 and 5% of total variation in composition, respectively. The major axis of variation was determined by sites with high sand cover versus sites that were distant from the river and had good water transparency/visibility. More or less perpendicular to this axis, there was a gradient from sites with a high cover of encrusting corals to sites with high turf algae cover. Species with high values along axis 1 (high sand cover) included *Haliclona* aff. *amboinensis*, *Echinodictyum mesenterinum*, *Paratetilla* aff. *bacca* and *Stylissa carteri*, whereas species with low values along axis 1 (good water visibility) included *Placospongia melobesioides* and *Petrosia corticata*. Species with low values along axis 2 included *Niphates* sp. 'blue', *Haliclona* (*Soestella*) 'brown' and *Amphimedon paraviridis*, whereas species with high values along axis 2, thus associated with areas of relatively high rubble and turf algae cover, included *Hyrtios erectus*, *Lamellodysidea herbacea* and *Agelas* aff. *nemoechinata*.

DISCUSSION

In general, coastal coral reefs are being increasingly exposed to elevated nutrient and sediment loads. Terrestrial runoff is therefore a growing concern for many coral reefs across the globe and can, if unabated, lead to serious degradation (Fabricius 2005). Although the coral reefs of the Derawan Islands have always been subjected to fluctuating sedimentation rates originating from the Berau River, particle influx may have gradually increased in recent years due to intensified terrestrial runoff into the river following large-scale deforestation as a result of logging and forest fires (Siegert et al. 2001, Cleary 2003, Cleary & Mooers 2004). The combination of terrestrial-based pollution and other sources of disturbance such as blast fishing

appear to have adversely affected the coral reefs of the Derawan Islands.

Average live coral cover across sites and depths was only 28.9%, hardly what one would consider pristine. The combined mean cover of rubble and dead coral (41.6%) was in fact well above the mean of live coral cover. Only 4 of the 36 transects, furthermore, had more than 50% live coral cover and would thus fall into the 'good' category of Gomez & Yap (1988), whereas 15 of the 36 transects had less than 25% live coral cover and would be classified as 'poor'. Various and possibly different scenarios may be responsible for the high cover of rubble. On the more offshore islands, the rubble is almost certainly the result of illegal blast fishing, a nefarious practice that has shifted to more remote sites following increased policing of the more accessible reefs (Erdmann 1998). Inshore, in contrast, the rubble may be the remnant vestiges of coral reefs that died in the more distant past; the exact sources of disturbance that led to this demise remain unknown. The large cover of dead coral midshore and in more shallow reefs suggests a different mechanism. Among other things, this may be the result of severe coral bleaching (Brown & Suharsono 1990), a crown-of-thorns starfish outbreak (DeVantier & Done 2007), pollution such as chronic oil spills, or a combination of these factors. In NW Java, Cleary et al. (2008) also observed high dead coral cover offshore. They also noted that offshore live coral cover had dropped dramatically between surveys conducted there in 1985 and 1995. As is probably the case in the Berau region, they attributed this loss to a number of documented sources of environmental stress including a marked increase in the number of crown-of-thorns starfish observed during that time period. In the present study, the highest number of sponge species (between 45 and 57) was found at the offshore sites of Kakaban (KaS) and some inshore reefs (BeL, BeS, RaR) at both depth intervals. These results are in concordance with the high sponge cover at those locations. The inshore sites of BeL, BeS and RaR are under the direct influence of the Berau River, and were typified by low visibility (less than 6 m); these reefs were also covered by a fine layer of sand, mud and silt. Large coral colonies were scarce in these sites with only small patches of encrusting and massive corals present; the dense fields of branching and tabular corals characteristic of many offshore sites were virtually absent. The marked absence of branching and tabular corals such as *Montipora* spp. and *Acropora* spp. from inshore sites is in line with findings that these species are less resilient to environmental stress than other corals such as the massive *Porites* (Edinger & Risk 2000).

In contrast to corals, environmental conditions in the Derawan Islands appeared to have a positive effect on

filter-feeding heterotrophic benthic taxa. Not only did we observe the highest number of species, including numerous records of unique species, at the inshore reefs, the sponge individuals also tended to be larger at these sites. In particular, the species *Echinodictyum mesenterinum*, *Ianthella basta*, *Iotrochota purpurea* and *Xestospongia testudinaria* attained larger sizes close to the river. This pattern was in marked contrast to other studies of the inshore sponge fauna in NW Java and SW Sulawesi (de Voogd et al. 2006, de Voogd & Cleary 2008). In both of these areas, the inshore sponge fauna was markedly depauperate compared to the offshore fauna, indicating that urban-related disturbances have had an overwhelming impact on all taxa of inshore reefs adjacent to the large cities of Jakarta and Makassar. The inshore reefs of the Derawan Islands had very low live coral cover, but the lack of a major conurbation and thus severe environmental stress has enabled other taxa to flourish and to a large extent occupy space that presumably was previously occupied by coral. In inshore sites close to Jakarta, for example, the majority of the substrate consisted of sand and turf algae (Cleary et al. 2008).

The lowest number of sponge species was found at several sites at the eastern side of the offshore Maratua atoll. The eastern side of Maratua borders the Makassar Strait, and has a narrow reef crest with a well-developed spur-and-groove zone in contrast to the wide reef on the western side (up to 300 m) (Tomascik et al. 1997). The eastern reef crest abruptly drops to several hundred meters and has a maximum visibility of more than 45 m. The reefs of the southeastern sides of Maratua have, however, been heavily damaged by blast fishing, and long patches of unstable coral rubble probably prevent recolonization of benthic taxa (Fox & Caldwell 2006). Some sites had very high rubble cover including MaE (almost 50% rubble) due to blast fishing, but this did not appear to have a pronounced effect on sponge composition. However, the sponges that we observed in these rubble fields were, in general, small and had the tendency to glue loose pieces of rubble together. These species may therefore play a hitherto undescribed, but important, role in consolidating the coral rubble and thus facilitating reef regeneration.

A total of 38 (22%) unique species (only found in a single transect) and a high number of singletons (26 species) were observed indicating that actual diversity is higher than recorded. Many of these unique species and singletons are new records for Indonesia or have not yet been described. Van Soest (1989) showed that different geographic regions within the Indo-West Pacific all have some endemic species but are, in the complement of their common species, very similar. Indeed, many of 59 mentioned common species

observed by van Soest (1989) at various localities were found in the Berau region. Within a sponge community, some species can be self-seeding and are important for maintaining the local sponge population, whereas others may act as a source for downstream regions. For example, *Amphimedon paraviridis* showed a more patchy distribution across the Derawan Islands and was sometimes locally abundant. This species was also very common in the Spermonde Archipelago, whereas it has only been sporadically observed from other regions within Indonesia. *Haliclona* aff. *amboinensis* had a pronounced preference for the more inshore sites, whereas *Petrosia nigricans* was found in most sites in moderate densities.

The species *Stelletta clavosa* accounted for a very high proportion of the total sponge abundance; however, this was largely due to very high abundances on 2 transects, at 5 and 10 m depth, near the island of Kakaban (KaS), where more than 500 individuals were recorded at both depth intervals. The southeastern side of Kakaban consists of a steep carbonate wall, where to the east the coral reef is interrupted by valleys of fine coral rubble overgrown with macroalgae (Renema 2006a,b). The fine coral rubble is highly unstable, and the small globular *S. clavosa* seems good at attaching to this substrate and as such is able to dominate the local sponge assemblage.

Quantitative studies on sponges in the Indo-Pacific region remain rare. However, in the Dampier Archipelago, Fromont et al. (2006) observed pronounced spatial heterogeneity in species composition. Composition varied with environmental factors such as substrate type, aspect, substrate configuration and depth. Likewise, in the central Torres Strait, Duckworth & Wolff (2007) found pronounced variation in the composition of dictyoceratid sponges across small spatial scales. They concluded that these patterns were largely species-specific and were explained by localised disturbance events, differences in food availability and patterns of water transport affecting larval dispersal.

Space, abiotic environmental conditions and habitat all contributed to structuring sponge assemblages across the Derawan Islands. Both spatial and abiotic environmental variables, however, explained more variation than local habitat structure. The most important habitat structure variables were sand cover and encrusting coral cover. There appeared to be a clear effect of the river on the cover of sand, with sites closer to the river having a higher sand cover. The cover of encrusting corals and turf algae was, in contrast, patchier, while the cover of coral rubble was higher at the most inshore and offshore sites. Generally, sand-dominated sites are associated with a low density and diversity of constituent species (Nakamura & Sano 2005, Carballo 2006). Sand cover in the Derawan

Islands, however, did not exceed 17% at 5 m depth and 32% at 10 m depth, compared to a high of >90% for inshore reefs in Jakarta Bay (Cleary et al. 2008). The most important abiotic environmental variables were distance from the Berau River and water visibility. Depth proved to be a poor predictor of variation in composition, in contrast to expectations: in previous studies, the diversity of coral reef sponges increased with depth (Adjeroud 1997, Hooper & Kennedy 2002, de Voogd et al. 2006, Fromont et al. 2006). Lesser (2006) suggested that food supply and, therefore, bottom-up processes significantly influenced the distribution and abundance of sponges with increasing depth in coral reefs located in Florida, Belize and the Bahamas. In the present study, rarefied species richness did not vary much between the 2 depth intervals. Remarkably, at a depth of 5 m, sponge cover was higher at the sites closer to the river than further away from the river. Our results may be explained by the pronounced onshore–offshore gradient in water visibility; much less light, for example, reached inshore reefs at 5 m than reached offshore reefs at 10 m. In marine environments, there are often pronounced depth-related gradients in a number of environmental parameters, including current velocity and temperature, but one of the most biologically important parameters is the amount of photic energy, which generally decreases with depth.

Although our set of spatial, environmental and habitat structure variables were able to explain a significant amount of spatial variation in sponge composition, a large amount of variation remained unexplained. In addition to previously mentioned factors that may be operating at different spatial scales, there are a number of unmeasured sources of variation. Biotic processes such as predation and competitive interaction play an important role in the population dynamics and size structure of sponges on coral reefs (Duffy & Paul 1992, Aerts & van Soest 1997). In addition to biotic processes, large-scale oceanographic processes or local physical differences that change with depth, such as flow velocities, might also structure sponge assemblages (Wilkinson & Evans 1989, Lesser 2006).

In conclusion, we found a highly significant relationship between the variation in sponge species composition and a set of spatial, environmental and habitat structure variables in the research area. Sponge diversity and abundance is notably high when compared to other surveyed coral reefs within the Indonesian Archipelago (van Soest 1989, Bell & Smith 2004, de Voogd et al. 2006, Cleary & de Voogd 2007).

Although disturbances, including riverine transport of sediments and nutrients inshore and blast fishing offshore, have adversely affected coral cover and composition, these disturbances do not appear to have had

a seriously adverse effect on sponge diversity and composition. The distinct difference in the impact of disturbance on corals and other benthic taxa differs from that found in areas close to major conurbations and merits further study.

Acknowledgements. We thank the following people for their help in various ways: M. Christianen, B. W. Hoeksema, J. van Oijen, N. Santodomingo, R. W. M. van Soest and the staff of Derawan Diver Resort and Nabucco Island Dive Resort. Fieldwork in Indonesia was made possible through financial support from the Schure-Beijerinck-Popping Foundation of the Royal Dutch Academy of Science (KNAW), the A. M. Buitendijk Fund and the J. J. ter Pelkwijk Fund. This work is part of L.E.B.'s PhD project, funded by The Netherlands Organisation for Scientific Research (ALW IPJ-07002). We are grateful to the Indonesian Institute of Science (LIPI) and Kementerian Negara Riset dan Teknologi (RISTEK) for providing permits for sampling in all localities in Indonesia.

LITERATURE CITED

- Adjeroud M (1997) Factors influencing spatial patterns on coral reefs around Moorea, French Polynesia. *Mar Ecol Prog Ser* 159:105–119
- Aerts LAM, van Soest RWM (1997) Quantification of sponge/coral interactions in a physically stressed reef community, NE Colombia. *Mar Ecol Prog Ser* 148:125–134
- Becking LE, Lim SC (2009) A new *Suberites* (Demospongiae: Hadromerida: Suberitidae) from the tropical Indo-West Pacific. *Zool Meded (Leiden)* 83:853–862
- Becking LE, Cleary DFR, de Voogd NJ, Renema W, de Beer M, van Soest RWM, Hoeksema BW (2006) Beta-diversity of tropical marine assemblages in the Spermonde Archipelago, Indonesia. *PSZN I: Mar Ecol* 27:76–88
- Bell JJ (2008) The functional roles of marine sponges. *Estuar Coast Shelf Sci* 79:341–353
- Bell JJ, Smith DKA (2004) Ecology of sponges in the Wakatobi region, south-eastern Sulawesi, Indonesia: richness and abundance. *J Mar Biol Assoc UK* 84:581–591
- Blanchet FG, Legendre P, Borcard D (2008) Forward selection of explanatory variables. *Ecology* 89:2623–2632
- Borcard D, Legendre P (2002) All-scale spatial analysis of ecological data by means of principal coordinates of neighbour matrices. *Ecol Model* 153:51–68
- Brown BE, Suharsono (1990) Damage and recovery of coral reefs affected by El Niño-related seawater warming in the Thousand Islands, Indonesia. *Coral Reefs* 8:163–170
- Carballo JL (2006) Effect of natural sedimentation on the structure of tropical rocky sponge assemblages. *Ecoscience* 13:119–130
- Cleary DFR (2003) An examination of scale of assessment, logging and ENSO-induced fires on butterfly diversity in Borneo. *Oecologia* 135:313–321
- Cleary DFR, De Vantier L, Giyanto, Vail L and others (2008) Relating variation in species composition to environmental variables: a multitaxon study in an Indonesian coral reef complex. *Aquat Sci* 70:419–431
- Cleary DFR, de Voogd NJ. (2007) Environmental determination of sponge assemblages in the Spermonde Archipelago, Indonesia. *J Mar Biol Assoc UK* 87:1669–1676
- Cleary DFR, Mooers AØ (2004) Butterfly species richness and community composition in forests affected. *J Trop Ecol* 20:359–367

- Cleary DFR, Becking LE, de Voogd NJ, Renema W, de Beer M, van Soest RWM, Hoeksema BW (2005) Cross-shelf diversity of sea urchins, sponges, mushroom corals and foraminifera in the Spermonde Archipelago, Indonesia. *Estuar Coast Shelf Sci* 65:557–570
- de Voogd NJ, Cleary DFR (2008) An analysis of sponge biodiversity and distribution at three taxonomic levels in the Thousand Islands/Jakarta Bay reef complex, West-Java, Indonesia. *PSZN I: Mar Ecol* 29:205–215
- de Voogd NJ, Cleary DFR, Hoeksema BW, Noor A, van Soest RWM (2006) Sponge beta diversity in the Spermonde Archipelago, Indonesia. *Mar Ecol Prog Ser* 309:131–142
- DeVantier LM, Done TJ (2007) Inferring past outbreaks of the crown-of thorns seastar from scar patterns on coral heads. In: Aronson R (ed) *Geological approaches to coral reef ecology*. Springer, New York, p 85–125
- Dray S, Legendre P, Peres-Neto PR (2006) Spatial modelling: a comprehensive framework for principal coordinate analysis of neighbour matrices (PCNM). *Ecol Model* 196: 483–493
- Duckworth AR, Wolff CW (2007) Patterns of abundance and size of Dictyoceratid sponges among neighbouring islands in central Torres Strait, Australia. *Mar Freshw Res* 58: 204–212
- Duffy JE, Paul VJ (1992) Prey nutritional quality and the effectiveness of chemical defenses against tropical reef fishes. *Oecologia* 90:333–339
- Edinger EN, Risk MJ (2000) Reef classification by coral morphology predicts coral reef conservation value. *Biol Conserv* 92:1–13
- English S, Wilkinson C, Baker V (1997) *Survey manual for tropical marine resources*. Australian Institute of Marine Science, Townsville
- Erdmann MW (1998) Status of coral communities of Pulau Seribu, 1985–1995. In: *Contending with global change*. Soemodijhardjo S (ed) *Proceedings: coral reef workshop, Pulau Seribu, Jakarta, Indonesia, 11–20 Sep 1995*. UNESCO, Jakarta, p 84–89
- Estradivari (2008) *Trouble or paradise: a scenario analysis of Berau's coastal zone*. MSc thesis, Vrije Universiteit Amsterdam, The Netherlands
- Fabricius KE (2005) Effects of terrestrial runoff on the ecology of corals and coral reefs: review and synthesis. *Mar Pollut Bull* 50:125–146
- Fox HE, Caldwell RL (2006) Recovery from blast fishing on coral reefs: a tale of two scales. *Ecol Appl* 16:1631–1635
- Fromont J, Vanderklift MA, Kendrick GA (2006) Marine sponges of the Dampier Archipelago, Western Australia: patterns of species distributions, abundance and diversity. *Biodivers Conserv* 15:3731–3750
- Gomez ED, Yap HT (1988) Monitoring reef condition. In: Kenchington RA, Hudson BET (eds) *Coral reef management handbook*. UNESCO regional office for science and technology for Southeast Asia (ROSTSEA), Jakarta, p 171–178
- Hooper JNA, Kennedy JA (2002) Small-scale patterns of sponge biodiversity (Porifera) on Sunshine Coast reefs, eastern Australia. *Invertebr Syst* 16:637–653
- Kaandorp JA (1986) Rocky substrate communities of the infralittoral fringe of the Boulonnais coast, NW France: a quantitative survey. *Mar Biol* 92:255–265
- Legendre P, Gallagher ED (2001) Ecologically meaningful transformations for ordination of species data. *Oecologia* 129:271–280
- Lesser MP (2006) Benthic–pelagic coupling on coral reefs: feeding and growth of Caribbean sponges. *J Exp Mar Biol Ecol* 328:277–288
- Mora C, Chittaro PM, Sale PF, Kritzer JP, Ludsin SA (2003) Patterns and processes in reef fish diversity. *Nature* 421: 933–936
- Nakamura Y, Sano M (2005) Comparison of invertebrate abundance in a seagrass bed and adjacent coral and sand areas at Amitori Bay, Iriomote Islands, Japan. *Fish Sci* 71: 543–550
- Renema W (2006a) Habitat variables determining the occurrence of large benthic foraminifera in the Berau area (East Kalimantan, Indonesia). *Coral Reefs* 25:351–359
- Renema W (2006b) Large benthic foraminifera from the deep photic zone of a mixed siliciclastic-carbonate shelf off East Kalimantan, Indonesia. *Mar Micropaleontol* 58:73–82
- Siegert F, Ruecker G, Hinrichs A, Hoffmann AA (2001) Increased damage from fires in logged forests during droughts caused by El Niño. *Nature* 414:437–440
- Skilleter GA, Russell BD, Degnan BM, Garson MJ (2005) Living in a potentially toxic environment: comparisons of endofauna in two congeneric sponges from the Great Barrier Reef. *Mar Ecol Prog Ser* 304:67–75
- Tomascik T, Mah AJ, Nontji A, Moosa MK (1997) *The ecology of Indonesia seas, Part two*. Periplus Editions, Singapore, p 643–1388
- van der Meij SET, Moolenbeek RG, Hoeksema BW (2009) Decline of the Jakarta Bay molluscan fauna linked to human impact. *Mar Pollut Bull* 59:101–107
- van Soest RWM (1989) *The Indonesian sponge fauna: a status report*. *Neth J Sea Res* 23:223–230
- Wilkinson CR, Evans EA (1989) Sponge distribution across Davies Reef, Great Barrier Reef, relative to location, depth, and water movement. *Coral Reefs* 8:1–7
- Wulff JL (2006) Ecological interactions of marine sponges. *Can J Zool* 84:146–166

Submitted: May 6, 2009; Accepted: September 30, 2009

Proofs received from author(s): November 30, 2009



Dynamics of benthic copepods and other meiofauna in the benthic boundary layer of the deep NW Mediterranean Sea

L. D. Guidi-Guilvard^{1,2,*}, D. Thistle³, A. Khripounoff⁴, S. Gasparini^{1,2}

¹CNRS, and ²Université Pierre et Marie Curie, Laboratoire d'Océanographie de Villefranche, 06234 Villefranche/Mer, France

³Department of Oceanography, Florida State University, Tallahassee, Florida 32306-4320, USA

⁴IFREMER centre de Brest, Laboratoire Environnement Profond, 29280 Plouzané, France

ABSTRACT: A continuous high-resolution time-series survey of the hyperbenthic community and local environmental conditions was conducted in the benthic boundary layer (BBL) of the DYFAMED-BENTHOS station (43° 24.61' N, 7° 51.67' E at 2347 m depth in the NW Mediterranean) between January 1996 and April 1998 using bottom-moored sediment traps and a current meter. Sediment traps were set 4 m above the bottom. Hyperbenthos was collected as 'swimmers', i.e. those organisms that are alive when they enter the traps but are not part of the particle flux. Identification of these organisms showed that ~90% were meiobenthic. Copepods dominated and comprised on average 75% of total swimmers. They were followed by nauplii (12%), annelids (7.8%), nematodes and bivalves (1.8% each), ostracods, isopods, and amphipods (1.2% altogether). Of the 3930 copepods examined, 4% were calanoids, 15% were harpacticoids and 81% were cyclopoids. Among the non-calanoid copepods, 25 species or groups of species were distinguished. Two benthic copepod species outnumbered all others: the cyclopinid genus *Barathricola* represented 90% of the cyclopoids, and the tisbid genus *Tisbe* represented 57% of the harpacticoids. Temporal variations, both intra- and interannual, in swimmer fluxes were high (26 to 361 ind. m⁻² d⁻¹), but not all groups/taxa/species were equally affected. Statistical analyses showed that these variations were the result of variability in both physical (near-bottom current) and trophic (particle flux) environmental factors. Organisms had both immediate and delayed responses, which involved passive (i.e. erosion, suspension) and active (i.e. emergence) reactions, as well as population growth. Most of the dispersal mechanisms previously reported for shallow-water benthic organisms were encountered, denoting the remarkable similarities in the general processes between coastal and deep-sea environments.

KEY WORDS: Deep sea · Swimmers · Hyperbenthos · Benthic storms · Resuspension · Emergence · Population growth · Biodiversity

Resale or republication not permitted without written consent of the publisher

INTRODUCTION

In the past several decades, there has been a considerable increase in knowledge about the functioning of open oceans, from surface waters to the deep-sea floor. Time-series observations with sediment traps, which collect material as it settles through the water column, have demonstrated that seasonal and episodic varia-

tions in surface productivity result in highly variable amounts of organic matter arriving at the seafloor (e.g. Karl et al. 2003), which is moreover subject to variable hydrodynamic conditions (e.g. Lampitt et al. 2001). The rapid delivery of fresh organic material to the deep-sea floor has important implications for life cycles of the benthos. In the food-limited deep sea, the abundance and biomass of benthic organisms depend on the

*Email: laurence.guidi@obs-vlfr.fr

amount of food reaching the sediment surface (e.g. Gooday 2002). For example, pulses of organic-rich detritus to the seafloor appear to be responsible for seasonal growth and reproduction in some megafaunal invertebrates (Billet et al. in press) and seasonal changes in macrofaunal densities (Drazen et al. 1998), sediment community respiration rates (Smith et al. 2002), bacterial densities (e.g. Lochte 1992), some foraminiferan species densities (Gooday 1988) and sediment geochemistry (Soetaert et al. 1996). But there is still little evidence that metazoan meiofaunal abundances increase following sedimentation events (Kalogeropoulou et al. 2009).

While deep-sea benthic ecology temporal surveys have focused on organisms living on and in the sediment, little attention has been paid within these studies to the invertebrate fauna present in the near-bottom waters. Single time-point investigations have brought insights on community and food-web structure as well as metabolism of these communities (e.g. Bühring & Christiansen 2001); however, many aspects concerning the ecology of this fauna are still unknown, in particular its dynamics and responses to local environmental variability.

Here we report the first continuous high-resolution time series for more than 2 annual cycles of the small hyperbenthos collected as 'swimmers' in sediment traps set 4 m above bottom (mab) in the benthic boundary layer (BBL) of the deep NW Mediterranean. Temporal variations of organism fluxes and species composition were analyzed and related to the simultaneously measured environmental variables.

MATERIALS AND METHODS

Study site. The present study was part of a long benthic time-series, the DYFAMED-BENTHOS survey (Guidi-Guilvard 2002), that was established in 1991 at the DYFAMED permanent station in the NW Mediterranean (Fig. 1) to investigate benthic–pelagic coupling. This 2300 m-deep station is relatively close to land (~52 km off Nice, France), but presents many of the characteristics of the open ocean with strong seasonal signals in surface productivity and essentially vertical particle fluxes. It was the site of the French Joint Global Ocean Flux Study (JGOFS) activities (Marty 2002, Karl et al. 2003) and is an ongoing permanent observatory of atmospheric and water column biogeochemical fluxes and processes (www.obs-vlfr.fr/sodyf/). The DYFAMED benthic site is situated on the side of the lower median fan valley of the Var Canyon. At the site, the terrain is relatively flat with muddy surface sediments (the silt-clay fraction comprises >94% of sediment dry weight) derived primarily from pelagic

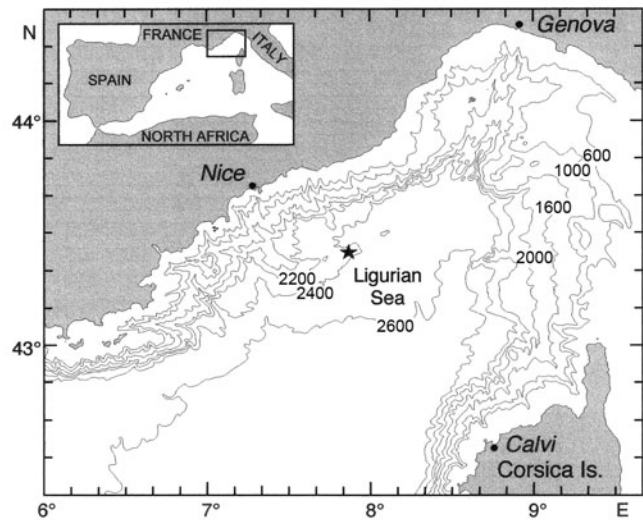

Fig. 1. Ligurian Sea, NW Mediterranean, showing the location of the DYFAMED station (2347 m depth)

sedimentation. The bottom water temperature is high (12.7°C), salinity is elevated (38.4‰) and average dissolved oxygen concentration is 4.7 ml l⁻¹ (Guidi-Guilvard 2002).

Sediment traps. The near-bottom sediment-trap mooring was deployed at the DYFAMED benthic site at a bottom depth of 2347 m (see Guidi-Guilvard 2002). Between January 1996 and April 1998, it was deployed 11 times, i.e. every 1.5 to 3.5 mo (Table 1). The mooring included 3 cylindro-conical (cylinder height 50 cm, cone height 60 cm, collection area 0.07 m², aspect ratio 3.66:1), baffled (cell diameter 10 mm), multisample sediment traps (labeled A, B, and C) supported in a rectangular frame (Fig. 2). Each trap had 5 bottles that were rotated under the collecting apparatus at predetermined intervals by a timer. Collection period per bottle varied between 5.5 and 21 d (mean = 14 d). All traps collected particles simultaneously at 4 mab. To inhibit biological activity, bottles were filled with 4% sodium borate-buffered formaldehyde in filtered seawater. Near-bottom current velocities were determined with an Aanderaa current meter every 120 min at a height of 12 mab until mid-June 1997.

Sample treatment. When the mooring was serviced, the collecting bottles were retrieved and replaced by clean ones. The samples were stored refrigerated. In the laboratory, the contents were gently rinsed with cold filtered seawater on a 100 µm sieve. Organisms and particles retained on the sieve were transferred to a Dolfus counting tray and swimmers were identified to the lowest possible taxon, counted and removed under an Olympus SZH dissecting microscope (96× magnification). The specimens were stored in a 4% buffered formaldehyde-filtered seawater solution until

Table 1. Station, deployment and sampling data for the near-bottom sediment trap of the DYFAMED station. Sediment traps were equipped with 5 collecting bottles. Abundance of swimmers in each bottle of sediment trap B is indicated in parentheses

Mooring bottle no.	Position	Start	Stop	No. days per bottle (No. swimmers)				
				1	2	3	4	5
Z6	43°25.32'N, 07°51.84'E	18/01/96	04/03/96	9 (39)	10 (18)	10 (34)	10 (38)	7 (22)
Z7	43°25.31'N, 07°51.91'E	06/03/96	07/05/96	12 (37)	12 (31)	12 (66)	12 (27)	14 (73)
Z8	43°25.26'N, 07°51.88'E	09/05/96	22/08/96	21 (177)	21 (223)	21 (115)	21 (73)	21 (51)
Z9	43°25.30'N, 07°51.87'E	28/08/96	12/11/96	17 (82)	15 (83)	15 (46)	15 (118)	14 (38)
Z10	43°25.32'N, 07°51.92'E	19/11/96	11/01/97	12 (105)	12 (55)	12 (30)	12 (76)	5.5 (44)
Z11	43°25.25'N, 07°51.80'E	16/01/97	08/04/97	14 (109)	17 (148)	17 (152)	17 (145)	17 (130)
Z12	43°25.21'N, 07°51.79'E	11/04/97	16/06/97	12 (86)	12 (98)	14 (112)	14 (95)	14 (84)
Z13	43°25.33'N, 07°51.86'E	18/06/97	27/08/97	14 (119)	14 (354)	14 (167)	14 (116)	14 (117)
Z14	43°25.26'N, 07°51.88'E	28/08/97	05/11/97	14 (184)	14 (278)	14 (194)	15 (199)	12 (80)
Z15	43°25.33'N, 07°51.86'E	19/11/97	18/01/98	14 (46)	14 (44)	12 (25)	12 (81)	8.7 (59)
Z16	43°25.30'N, 07°51.90'E	06/02/98	15/04/98	14 (125)	14 (57)	14 (41)	14 (51)	12 (56)

analyzed. The swimmer-free particles were immediately transferred back to the corresponding bottles and kept refrigerated. Further processing of the particles

included desalting, freeze-drying, estimation of dry mass and analyses of chemical compounds following the procedures described in Khrpounoff et al. (1998).

Identification. The benthic copepods from Trap B (Fig. 2) were identified. For counting, specimens were transferred to drops of glycerol on microscope slides and separated to order: Calanoida, Cyclopoida, Harpacticoida. The distinction between Cyclopoida and Poecilostomatoida was not made, following Boxshall & Halsey (2004). The copepod fauna of the deep Mediterranean is far from completely described, so for the cyclopoid and harpacticoid species encountered, we noted important taxonomic characters and drew a lateral habitus view of an adult female (or male when a female was not available) with the aid of a Nikon Labophot-2 compound microscope equipped with a drawing tube. With this information, we created a key and identified individuals in copepodite stages I through VI to working species. For the harpacticoid families Ectinosomatidae, Miraciidae (formerly Diosaccidae) and Ameiridae, the species-distinguishing characters do not appear until the adult molt. Therefore, the specimens of each of these families were treated as single units. To associate a working species with a described taxon, a specimen was dissected, its appendages mounted and important characters were recorded and illustrated. The keys in Huys et al. (1996), Boxshall & Halsey (2004) and the primary literature were used to determine the described taxon that came closest to matching the species.

Data and statistics. Because sampling durations were unequal, swimmer abundances were converted to fluxes, i.e. ind. $m^{-2} d^{-1}$. In the graphs of maximum current velocities (V_{max}) and swimmer fluxes, the representative point was plotted at the centre of the corresponding collection period.

Relationships between organism fluxes and environmental variables were analyzed using principal component analysis (PCA); environmental variables were

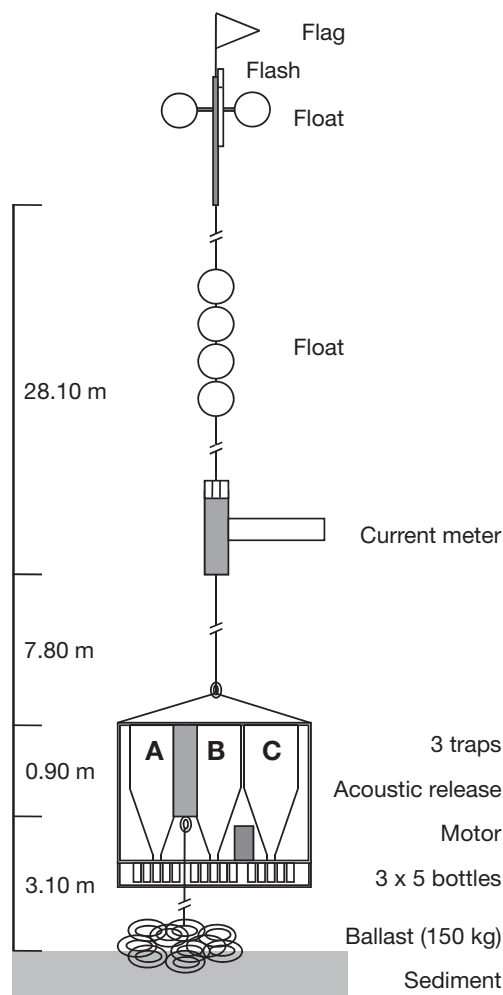

Fig. 2. Schematic representation (not to scale) of the near-bottom mooring deployed on the DYFAMED station between January 1996 and April 1998

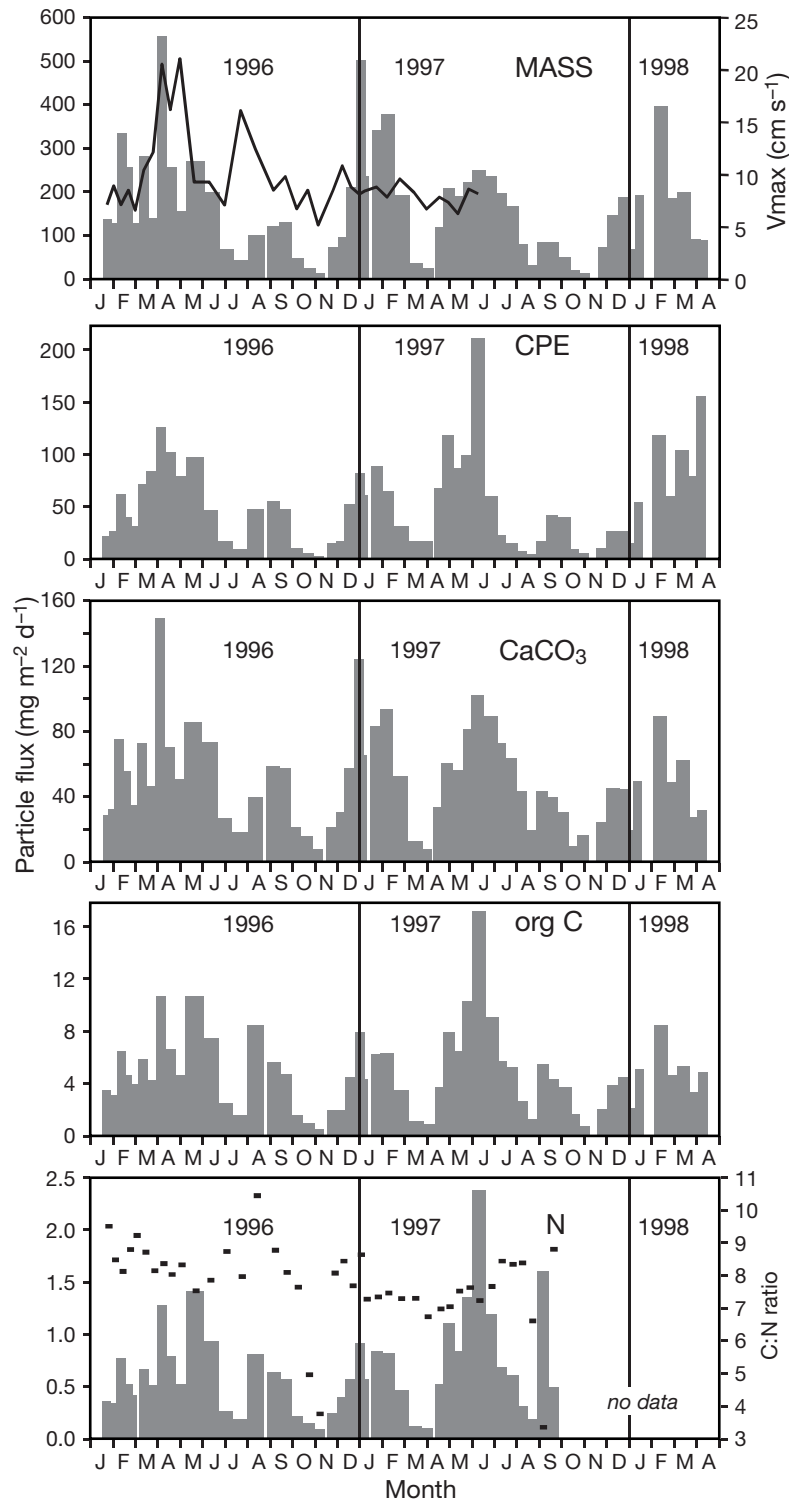

Fig. 3. Particle flux measured 4 m above bottom between 18 January 1996 and 15 April 1998 (histograms, units on the left): total dry flux (MASS), flux of chloroplast pigment equivalents (CPE, measured fluorometrically), calcium carbonate (CaCO_3), organic carbon (org C) and nitrogen (N). Black symbols in bottom panel are the corresponding C:N ratios (scale on the right). Black curve in the top panel is the maximum current velocity (V_{\max}) recorded 12 m above bottom during each collection period between 18 January 1996 and 16 June 1997 (units on the right)

set as active, while swimmer fluxes were projected as supplementary variables in the resulting factorial space. To compare particulate matter fluxes to fluxes of dominant copepod life-history stages, we used cross-correlation analyses followed by Spearman rank tests. Each dataset (factorial axis and swimmer fluxes) was treated as a stationary time series, and paired correlations in 14-d increments were computed from 0 to 84 d (i.e. the lag of the second data set relative to the first data set). Flux data were not transformed. Missing values (V_{\max} after 16 June 1997, nitrogen fluxes and C:N ratios after 25 September 1997) were replaced by the average value of the corresponding variable. All analyses were performed with TANAGRA (Rakotomalala 2005).

RESULTS

Environmental variables

Environmental variables will be described briefly in this section and will only be discussed further from the perspective of the swimmers.

Fig. 3 (top panel) shows the maximum current velocities recorded during each collection period between mid-January 1996 and mid-June 1997. At the DYFAMED station, bottom current speed rarely exceeds 10 cm s^{-1} . For example, in 1995, the same mooring measured a mean bottom current speed of 3.70 cm s^{-1} with only one value reaching a maximum of 10.18 cm s^{-1} (A. Khripounoff unpubl. data). In 1996 however, bottom current speed was higher, with an annual mean of 5.28 cm s^{-1} . A total of 4 benthic storms (see Aller 1989) with peak velocities between 13 and 21 cm s^{-1} occurred in April, and maximum current speed rose again (16 cm s^{-1}) at the end of July. In 1997, the incomplete data set (mean current speed = 3.73 cm s^{-1} , maximum speed = 9.42 cm s^{-1}) nevertheless suggests that the bottom hydrodynamic conditions were comparable to those observed in 1995.

Fig. 3 also shows the particle fluxes measured in the samples after removal of the swimmers. There were strong seasonal signals in the input of particles to the bottom, with marked peaks in winter through spring, and lower secondary pulses at the end of

summer. Mass and calcium carbonate (CaCO_3) fluxes distributions were comparable, with a maximum value (554.59 and 149.73 $\text{mg m}^{-2} \text{d}^{-1}$, respectively) recorded in early April 1996 at the onset of the first benthic storm. For all the other fluxes measured, i.e. chloroplastic pigment equivalents (CPE), organic carbon (org C) and nitrogen (N), the maximum input occurred in June 1997 (212.45 $\mu\text{g m}^{-2} \text{d}^{-1}$, 17.23 and 2.38 $\text{mg m}^{-2} \text{d}^{-1}$, respectively). A second N-flux peak, corresponding to a very low C:N ratio (3.36), occurred 3 mo later (1.60 $\text{mg m}^{-2} \text{d}^{-1}$).

Interannual variability between 1996 and 1997 occurred in the magnitude, timing and duration of the input peaks (Fig. 3); however, concerning the overall annual fluxes it was low. Fig. 4 shows that while the CPE and org C annual fluxes were equivalent in both years, mass and CaCO_3 annual fluxes were slightly higher in 1996, probably reflecting resuspension by strong bottom currents.

Swimmer composition

A total of 5253 organisms were removed from the 55 collecting bottles, each containing between 18 and 354 swimmers larger than 100 μm (Table 1). Copepods (excluding nauplii) largely dominated (Table 2). Nauplii were the second most abundant group and appeared to belong almost exclusively to the harpacticoids. Annelids were essentially larval polychaetes.

Of the 3949 copepods sorted, 19 were damaged and were not considered further. Of the 3930 copepods examined, 4% were calanoids, 15% were harpacticoids and 81% were cyclopoids. Among the non-

calanoid copepods, 25 working species/groups were distinguished, 2 of which were cyclopoids (SP101 and SP102) and 23 harpacticoids (SP1 to SP22, Cer and Unk) (Table 3); 5 taxa were groups of species, i.e. the oncaeids SP102, the ectinosomatids SP5, the miraciids SP1121, the ameiriids SP13 and a group of unidentifiable specimens (Unk). All the others were single species, for 6 of which we could not establish the family name; 2 are new species, the cyclopinid *Barathricola* (SP101) and the huntermanniid *Talpina* (SP7) (Martínez Arbizu pers. comm.). Most harpacticoid species/groups were poorly represented (1 to 54 individuals). Among all the copepods listed in Table 3, 2 species were particularly abundant: SP101 represented 90% of the cyclopoids, and SP1 (the tisbid *Tisbe*) represented 57% of the harpacticoids. Juvenile individuals (copepodites) comprised 42% of both the total cyclopoids and harpacticoids (Table 3). However, they were more represented in the oncaeids (SP102) and in *Tisbe* (SP1) (65 and 62% of the total individuals, respectively) than in *Barathricola* (SP101) (39%). Adult females outnumbered adult males in the cyclopoids (sex ratio = 0.63), while the situation was reversed in harpacticoids (sex ratio = 0.37).

The most remarkable feature of the copepod community structure was the numerical dominance of only 2 benthic copepod species, *Barathricola* and *Tisbe* which together represented ~93% of the benthic copepods and 61% of the total swimmers. Considering that among the taxa examined only the calanoids and SP102 were planktonic, we can conclude that over 90% of the swimmers collected were benthic.

Swimmer temporal fluctuations

Fig. 5A shows the temporal distribution of total swimmer, total copepod and nauplii fluxes. Total swimmer

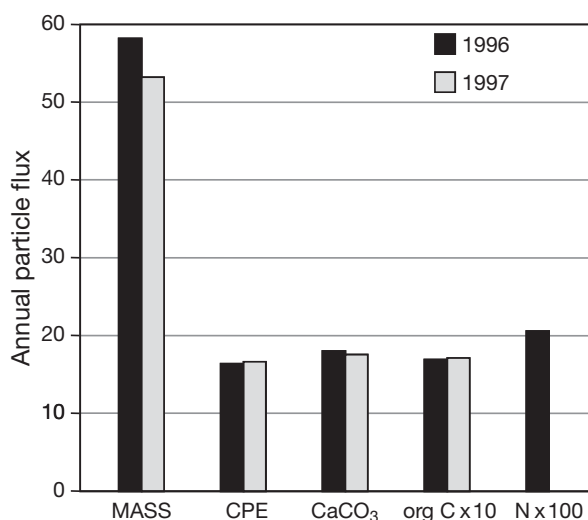

Fig. 4. Annual particle fluxes measured 4 m above bottom in 1996 and 1997. Units for MASS, CaCO_3 , org C and N flux are $\text{g m}^{-2} \text{yr}^{-1}$. Units for CPE flux are $\text{mg m}^{-2} \text{yr}^{-1}$. Values multiplied by 10 for org C flux, and by 100 for N flux. N flux for 1997 not calculated due to missing data

Table 2. Taxonomic composition, abundance and contribution to total swimmers collected 4 m above bottom between 18 January 1996 and 15 April 1998 at the DYFAMED station. Others: cumaceans, tanaids, gastropods, sea stars, chaetognaths and appendicularians

Taxon	Abbreviation	Number	%
Copepods	Cop	3949	75.2
Nauplii	Nau	608	11.6
Annelids	Ann	409	7.8
Nematodes	Nem	101	1.9
Bivalves	Biv	96	1.8
Ostracods	Ost	29	0.6
Isopods	Iso	20	0.4
Amphipods	Amp	14	0.3
Others	Oth	27	0.5
Total		5253	100

Table 3. General features of the non-calanoïd copepod species/groups. Single species are SP101 for cyclopoids, SP1 to 4, SP6 to 10, SP12, SP14 to 20, SP22 and Cer for harpacticoids; groups are SP102 for cyclopoids, SP5, SP1121, SP13 and Unk for harpacticoids. Sex ratio was calculated as the proportion of females to total adults. The immature copepodite stages are grouped under juveniles

Family	Genus	Working species or group	Number				Sex ratio
			Females	Males	Juveniles	Total	
Cyclopoida							
Cyclopinidae	<i>Barathricola</i>	SP101	1095	633	1120	2848	0.63
Oncaeidae	<i>Oncaea</i>	SP102	70	44	211	325	0.61
Total			1165	677	1331	3173	0.63
Harpacticoida							
Tisbidae	<i>Tisbe</i>	SP1	55	75	210	340	0.42
?		SP2	9	18	1	28	0.33
?		SP3	2	3	1	6	0.40
?		SP4	3	1	5	9	0.75
Ectinosomatidae		SP5	20	26	8	54	0.43
Huntermanniidae	<i>Talpina</i>	SP7	6	7	0	13	0.46
Canthocamptidae		SP8	4	1	1	6	0.80
Canthocamptidae		SP9	1	5	1	7	0.17
Canthocamptidae		SP10	4	6	1	11	0.40
Miraciidae		SP1121	2	1	0	3	0.67
Ameiridae		SP13	2	3	0	5	0.40
Argestidae		SP6	5	0	1	6	1.00
Argestidae	<i>Mesocletodes</i>	SP12	3	0	0	3	1.00
Argestidae	<i>Stylicletodes</i>	SP14	1	0	0	1	1.00
Argestidae		SP15	2	2	0	4	0.50
Argestidae		SP16	2	0	1	3	1.00
Argestidae		SP17	1	2	1	4	0.33
Argestidae		SP19	1	0	0	1	1.00
Argestidae	<i>Mesocletodes</i>	SP22	0	18	0	18	0.00
?		SP18	1	1	0	2	0.50
?		SP20	1	1	0	2	0.50
Cerviniidae	<i>Pontostatiotes</i>	Cer	0	3	10	13	0.00
?		Unk	0	43	11	54	0.00
Total			125	216	252	593	0.37

fluxes varied greatly over time (26 to 361 ind. $m^{-2} d^{-1}$). Their distribution generally matched that of total copepods. Major copepod flux peaks occurred in early June 1996, early July 1997 and late September 1997. Nauplii fluxes were more or less out of phase with those of copepods, with one major peak in late October 1996. Nauplii were not always present in the samples, nor were annelids, bivalves or nematodes (Fig. 5B). Major annelid and bivalve flux peaks were concomitant in late November 1996, early July 1997 and early September 1997. Bivalves also peaked in early April 1996, but annelids did not. Mean nematode flux was generally low (<2 ind. $m^{-2} d^{-1}$), but the occurrence of these organisms increased in early April and May 1996 (8 ind. $m^{-2} d^{-1}$). The fluxes of the 3 copepod orders, cyclopoids, harpacticoids and calanoids, followed different patterns (Fig. 5C). The cyclopoid flux pattern roughly followed that of total copepods, matching the same 3 main peaks. Harpacticoid fluxes were low in 1996 with a peak in late November. In 1997, the first flux peak in early July occurred at the same time as that of the cyclopoids, but the second occurred earlier

in September. Calanoïd fluxes were low and never exceeded 10 ind. $m^{-2} d^{-1}$. Fig. 5D shows the fluxes of the 2 dominant copepod species, SP101 and SP1. Due to the outstanding dominance of SP101 within the cyclopoids, its temporal flux pattern coincided with that of the order. For SP1, only the flux peak in early July 1997 was concomitant with that of the harpacticoids. Other main peaks occurred either 1 mo earlier (in late October 1996) or later in the month (in September 1997) than those of the order.

Temporal variations in swimmer fluxes were high within years as well as between years. Fig. 6 shows that the mean annual flux of copepods and annelids in 1997 was more than twice that measured in 1996. The trend was reversed for nematodes, which were slightly more abundant in the 1996 samples. Nauplii, bivalve and calanoïd mean annual fluxes were roughly the same in both years. In contrast, those of the 2 dominant copepod species differed greatly. They increased by a factor of 3 for SP101 and by a factor of more than 4 for SP1. Among the non-calanoïd copepods, species/groups composition also varied between 1996 and

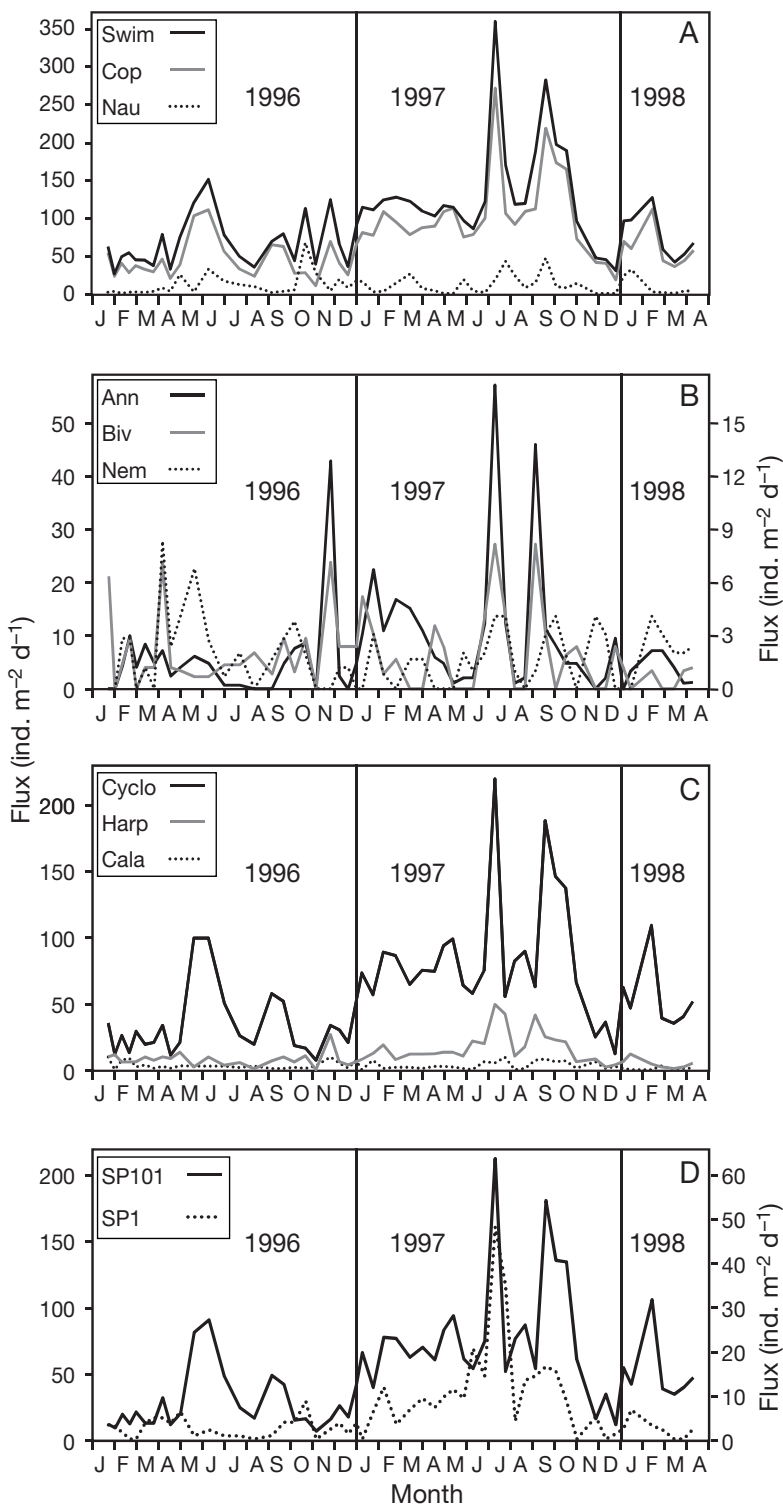

Fig. 5. Swimmer flux measured 4 m above bottom between 18 January 1996 and 15 April 1998. (A) total swimmers (Swim), total copepods (Cop) and nauplii (Nau); (B) annelids (Ann) (units on left), bivalves (Biv) and nematodes (Nem) (units on right); (C) cyclopoids (Cyclo), harpacticoids (Harp) and calanoids (Cala); (D) flux of the 2 dominant copepod species, the cyclopoid *Barathricola* (SP101) and the harpacticoid *Tisbe* (SP1) (units on right)

1997. Of the 25 species/groups distinguished (Table 3), 3 (SP4, SP6, SP20) only occurred during the first year of the study, and 6 (SP1121, SP12, SP14, SP15, SP18, SP19) only during the second year. Since more harpacticoid species/groups were present in 1997, harpacticoid species diversity was higher in 1997 than in 1996. Moreover, while only the oncaeids (SP102) were equally represented in both years, out of the 15 remaining species/groups, 3 (SP2, SP3, SP9) were more abundant in 1996 and 12 were more abundant in 1997.

Swimmers and environmental variables

To understand the swimmer temporal variations, we ran PCA in which active variables were those of the environment. The first 3 factorial axes explained 86.28% of environmental variability (Table 4). Axis 1 (57.35%) was strongly correlated to the different particle fluxes, and to V_{\max} to a much lesser extent, in the negative values. Axis 2 (17.63%) was strongly correlated to C:N ratios and V_{\max} in the negative values, and to N-fluxes in the positive values. Axis 3 (11.30%) was significantly correlated to V_{\max} in the positive values, and to C:N ratios in the negative values. Axis 1 can thus be interpreted as representing 'particle flux' increasing in the negative values, Axis 2 'current velocities that decrease particle quality' increasing in the negative values and Axis 3 'current velocities that increase particle quality' increasing in the positive values. Because strong near-bottom flow is likely to erode and resuspend refractory sediment, it will increase both near-bottom particle fluxes (Axis 1) and the C:N ratio of trapped particles by incorporating 'old' particles into the 'fresh' influx (Axis 2) (see Lampitt 1985). On the other hand, current velocities in excess of 7 cm s^{-1} are sufficient to elicit resuspension of loose, freshly deposited, high quality aggregates (rebound flux) (see Lampitt et al. 2001), thereby decreasing the C:N ratio of trapped particles (Axis 3). Consequently, Axis 2 would correspond to 'erosion current' and Axis 3 to 'rebound current'.

Fluxes of 33 swimmer taxa/groups/species (i.e. 8 higher taxa/groups, calanoids and 24 out of the 25 working species/groups) were projected as supplementary variables in the planes defined by the first 3 factorial axes (Fig. 7). Highest dispersion of swimmer fluxes occurred along Axis 2. Of the 99 resulting correlation

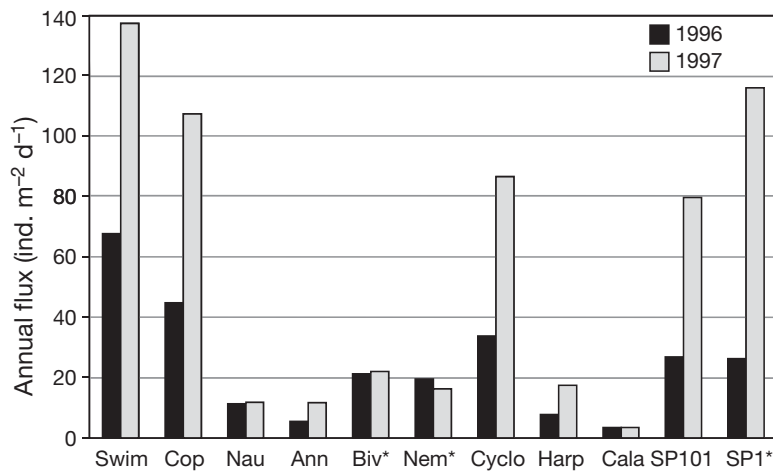

Fig. 6. Mean annual swimmer flux (ind. m⁻² d⁻¹) measured 4 m above bottom in 1996 and 1997. Total swimmers (Swim), total copepods (Cop), nauplii (Nau), annelids (Ann), bivalves (Biv*), nematodes (Nem), total cyclo-pods (Cyclo), harpacticoids (Harp), calanoids (Cala), *Barathricola* (SP101) and *Tisbe* (SP1). *values multiplied by 10

coefficients, 22 (involving 14 taxa/groups/species) were significant ($p \leq 0.05$). Nematode (Nem) and SP6 fluxes increased with increasing particle flux ($r = -0.36$ and -0.30 , respectively). They also increased with increasing erosion current ($r = -0.23$ and -0.24 , respectively), as did SP2 and SP4 fluxes ($r = -0.22$ and -0.43 , respectively). This indicates that these benthic taxa/species were passively resuspended by strong bottom flow. Nematode and SP4 fluxes, along with those of nauplii, ostracods, isopods, 'others', SP7, SP18 and SP20 increased with increasing rebound current ($r = 0.27$, 0.32 , 0.22 , 0.24 , 0.24 , 0.37 , 0.26 , 0.23 and 0.23 , respectively), indicating that they entered the water column on rebound aggregates. The fluxes of nauplii, ostracods and SP5 increased when particle flux was low ($r = 0.28$, 0.30 and 0.25 , respectively), probably because these organisms entered the water column actively in response to food shortage. The fluxes of ostracods, SP10 and SP18 increased when erosion current decreased ($r = 0.26$, 0.29 and 0.25 , respectively), revealing avoidance of resuspension by strong bottom flow. Only SP102 fluxes were negatively correlated to rebound current ($r = -0.34$).

Fig. 8 shows the temporal patterns of environmental conditions summarized by the observation coordinates on the 3 factorial axes (top) along with those of SP101 and SP1 fluxes (bottom). It suggests that the temporal fluctuations in these 2 species' fluxes involved lagged reactions. Because PCA Axis 1 includes the food for deep-living organisms, any improved correlation in the negative values of this axis after lagging the swimmer fluxes by 1 and 2 collection periods would reveal a population growth response. This was indeed observed for SP101 and SP1 fluxes ($r = -0.22$ and -0.38 ,

respectively), and for annelid and SP4 fluxes ($r = -0.24$ and -0.27 , respectively) after 28 d. Concerning the former, a cross-correlation analysis (Fig. 9) confirmed a growth response. It showed that a peak of SP101 juveniles within 14 d following the food influx led to a peak of adults within the next 14 d, and that a peak of SP1 juveniles between 14 and 28 d led to a peak of adults between 28 and 42 d. Moreover, the 14-d lagged PCA displayed effects that persisted in time. The correlation coefficients of SP5, SP17 and SP22 fluxes with Axis 1 in the positive values (low particle flux) were improved ($r = 0.33$, 0.25 and 0.26 , respectively), suggesting that aggravated food shortage enhanced the active entry into the water column of these groups/species. The correlation coefficient of some species fluxes with increasing erosion current (Axis 2 in the negative values) were either improved (SP3, $r = -0.29$; SP6, $r =$

-0.41) or remained significant (SP4, $r = -0.34$), indicating that once eroded by strong bottom current, these species accumulated in the water column and did not re-enter the benthos within the following 2 wk. The correlation coefficients of nematodes, SP17 and SP18 fluxes with increasing rebound current (Axis 3 in the positive values) were also improved ($r = 0.30$, 0.29 and 0.35 , respectively), indicating that these organisms accumulated in the water column on rebound aggregates. Finally, increased erosion current (Axis 2 in the negative values) led to a significant decrease in the fluxes of annelids, bivalves, calanoids, SP101, SP1, SP8, SP10, SP17, SP18 and SP22 ($r = 0.33$, 0.25 , 0.34 , 0.34 , 0.26 , 0.24 , 0.23 , 0.40 , 0.34 and 0.41 , respectively) within the following 2 wk. This suggests that the organisms either avoided the water column (active behavior) or that erosion had a lethal effect on them (passive). Table 5 summarizes the different responses revealed by the statistical analyses for 23 of the 33 swimmer taxa examined.

Table 4. Correlation coefficients between active variables and principal components analysis factorial axes. Bold: $p < 0.05$. MASS: total dry flux; CPE: chloroplastic pigment equivalents; Org C: organic carbon; V_{\max} : maximum current velocity

Active variables	Axis 1	Axis 2	Axis 3
MASS	-0.85	-0.14	-0.15
CPE	-0.84	+0.12	+0.05
CaCO ₃	-0.94	-0.07	-0.07
Org C	-0.95	+0.13	-0.06
N	-0.83	+0.36	+0.12
C:N	-0.20	-0.80	-0.48
V_{\max}	-0.29	-0.64	+0.71

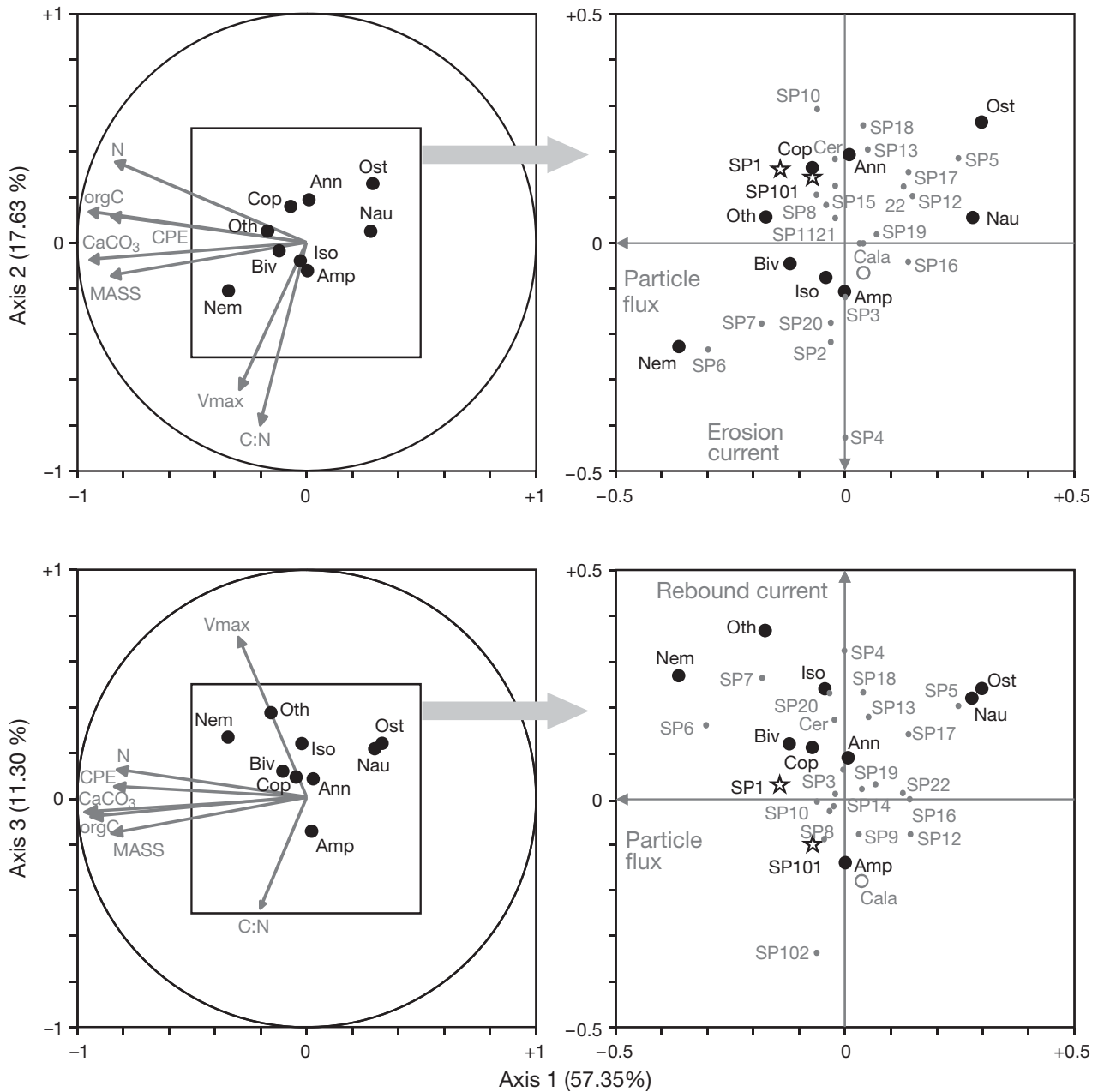

Fig. 7. Principal component analysis correlation circles showing the distribution of the different swimmer taxa projected as supplementary variables (dots and stars indicate tips of vectors) in the planes defined by the first 3 factorial axes explaining 86.28% of environmental variability. Left panels display only major taxa (large dots). Right panels are close-ups that display all taxa except total cyclopoids, harpacticoids and unidentified specimens (small grey dots are species/groups, stars are the 2 dominant species). In the close-up of Axes 1 and 2 (top), labels of SP9, SP14 (near the centre) and SP102 (near SP101) were omitted. Likewise for SP2, SP15 and SP1121 (near the centre) in the close-up of Axes 1 and 3 (bottom). MASS: total dry flux; CPE: chloroplatic pigment equivalents; Org C: organic carbon; V_{\max} : maximum current velocity. See Tables 2 & 3 for other abbreviations

DISCUSSION

General considerations

In bathyal and abyssal habitats, the benthopelagic community or hyperbenthos (see Mees & Jones 1997) has typically been sampled with specially designed

plankton nets, benthic trawls and nets or pumps on submersibles. These techniques have been used to collect samples for species descriptions, community structure (e.g. Wishner 1980) and food-web analyses (e.g. Bühring & Christiansen 2001), as well as metabolism measurements (e.g. Smith et al. 1987). They have led to the general agreement that the near-bottom plank-

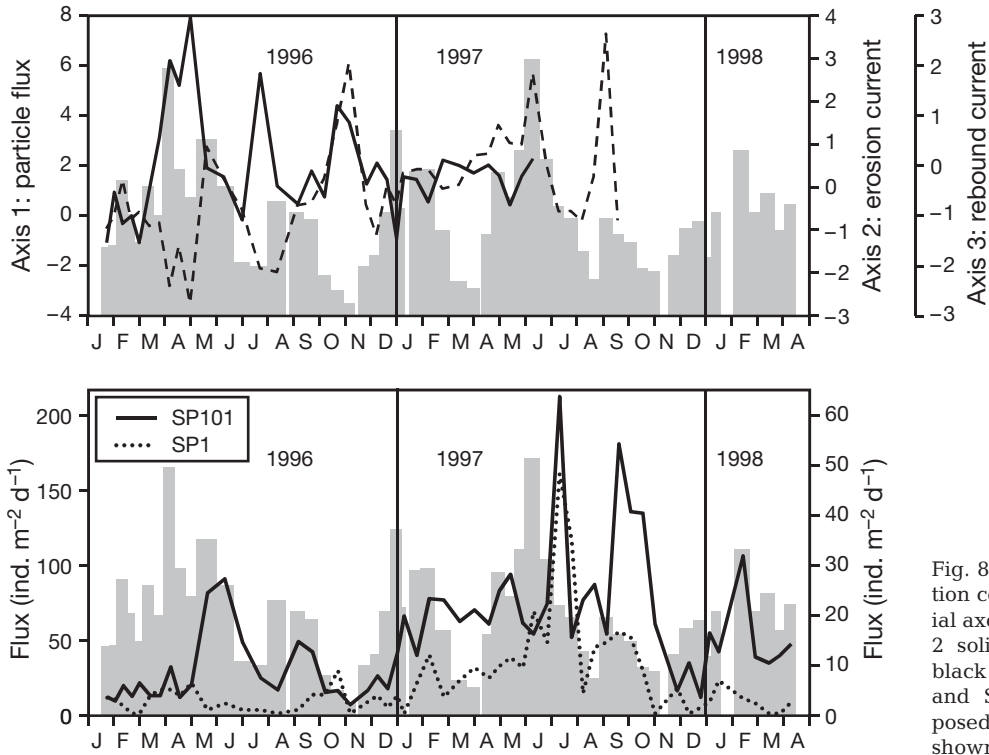

Fig. 8. Temporal pattern of observation coordinates on the 3 first factorial axes (top) (Axis 1 histogram, Axis 2 solid black line, Axis 3 dashed black line; arbitrary units). SP101 and SP1 fluxes (bottom) superimposed on pattern of Axis 1 (units not shown) (SP1 flux units on the right)

ton of most deep-sea environments is numerically dominated by copepods, which contribute between 50 and >90% of the benthopelagic community. The present study in the deep NW Mediterranean, with a different sampler (i.e. sediment traps) also showed a high dominance of copepods, which comprised on average 75% of the organisms collected. While previous investigations essentially sampled planktonic organisms, the great majority (90%) of the organisms collected in the present study were benthic. This discrepancy could be caused by the large mesh sizes used in traditional benthopelagic studies ($\geq 183 \mu\text{m}$) and/or by the

different heights above the bottom sampled (generally ≥ 10 mab, but see Smith et al. 1987). The differences could also result from the gear itself or from specificities of the deep Mediterranean. Note that virtually none of the traditional benthopelagic studies sampled the same location more than once, probably because of logistic constraints. Sediment traps currently used to measure oceanic particle fluxes, inevitably collect swimmers (see Karl & Knauer 1989). While these are usually removed (and discarded) because they artificially augment the trap contents, one may be missing a chance to obtain time-series samples of an organism of

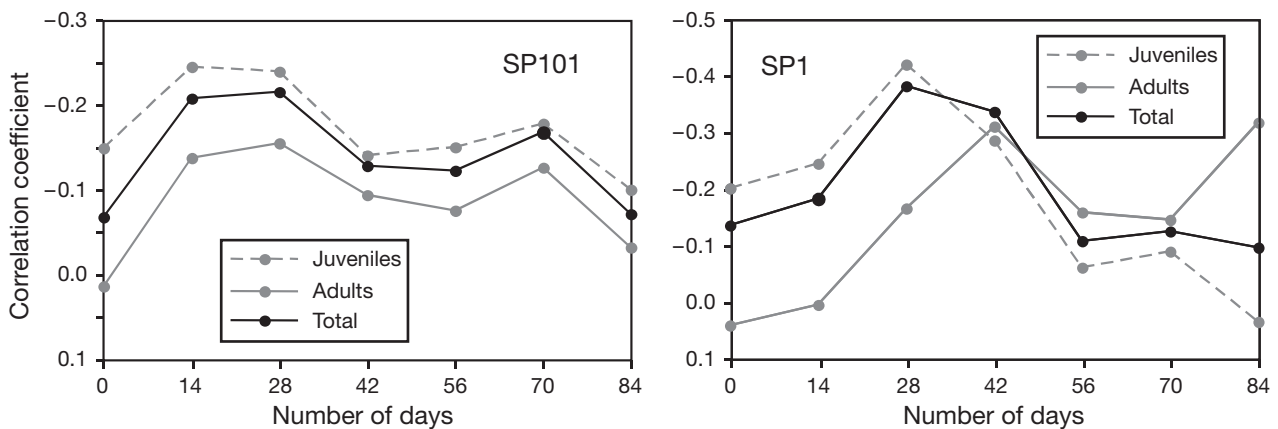

Fig. 9. Correlations between principal component analysis Axis 1 and fluxes of the different life history stages of SP101 and SP1 lagged in 14-d increments

Table 5. Summary of the responses to environmental variability in 23 swimmer taxa/groups/species. Principal component analyses axes information is in italics and the corresponding sign in parentheses. Only the significant ($p \leq 0.05$) correlation coefficients are displayed. In the lagged responses, only the improved coefficients are indicated, unless they are in parentheses. Cala: calanoids; see Tables 2 & 3 for other abbreviations

Taxon/ group/ species	Immediate responses				Delayed responses			
	Passive resuspension Erosion	Entry into water column	Active swimming Avoidance of Erosion	Growth (28 d lag)	Active Entry	Enhancements (14 d lag) Passive	Avoidance/ lethal effect	
	<i>Increased erosion Axis 1 (-)</i>	<i>Increased rebound Axis 3 (+)</i>	<i>Increased erosion Axis 2 (-)</i>	<i>Increased particle flux Axis 1 (-)</i>	<i>Decreased particle flux Axis 1 (+)</i>	<i>Increased erosion Axis 2 (-)</i>	<i>Increased erosion Axis 2 (-)</i>	
Nau	+0.22	+0.28					+0.33	
Ann				-0.24		+0.30	+0.25	
Nem	-0.36	+0.27						
Biv								
Ost	+0.24	+0.30	+0.26					
Iso	+0.24							
Oth	+0.37							
Cala							+0.34	
SP101				-0.22			+0.34	
SP102					-0.34			
SP1				-0.38			+0.26	
SP2	-0.22							
SP3						-0.29		
SP4	-0.43	+0.32		-0.27		(-0.34)		
SP5		+0.25			+0.33			
SP6	-0.30					-0.41		
SP7		+0.26						
SP8							+0.24	
SP10			+0.29				(+0.23)	
SP17					+0.25		+0.40	
SP18	+0.23		+0.25			+0.29	+0.34	
SP20	+0.23					+0.35		
SP22					+0.26		+0.41	

interest. On a few occasions, sediment traps have been used to study seasonal variations of mid-water zooplankton in 'hostile' environments such as the polar regions (Hargrave et al. 1989, Seiler & Brandt 1997, Willis et al. 2006). Most studies have focused on the analysis of the 'contaminating' effect of swimmers on particle flux organic content (e.g. Steinberg et al. 1998). A few studies have used sediment traps to investigate the occurrence of meiofaunal taxa in the water column of shallow coastal settings (e.g. Hagerman & Rieger 1981, Shanks & Edmondson 1990). None have previously been conducted in the BBL of the deep sea.

The BBL, i.e. the layer of water typically tens of metres thick above the seabed, is a highly variable environment. According to Lampitt (1985) and Lampitt et al. (2000, 2001), material collected in near-bottom sediment traps gives a measure of apparent flux as opposed to the primary flux measured higher in the water column. Traps set within the BBL collect material that is a mixture of particles from 3 sources: (1) particles that have settled directly from the overlying water column (primary flux), (2) mineral particles that have been eroded from the sediment (erosion flux) and (3) freshly deposited particles that have been resuspended from the local seabed (i.e. rebound flux). The contribution of the latter 2 to the former depends on bottom current speed, which can be highly variable, as shown in the present study. Gardner & Richardson (1992) reported that burst events lift particles off the seafloor and resuspension occurs primarily when bottom current speed exceeds a critical value, i.e. ~ 11 to 12 cm s^{-1} for sediment erosion and $\sim 7 \text{ cm s}^{-1}$ (at 1 mab, Lampitt 1985) for resuspension of newly arrived detrital aggregates. These authors suspected that quite subtle changes in the near-bottom current regime would have substantial effects on the structure of both benthic and benthopelagic communities.

The metazoan meiobenthic community at the DYFAMED station is typical of deep-sea muddy bottoms (see Giere 2009), with densities ranging from 133 to 770 ind. per 10 cm^2 (Guidi-Guilvard 2002). Nematodes dominate (88.8%) and are followed by copepods (harpacticoids and cyclopoids) along with their nauplii (9.6%) and annelids (1.1%). Other groups are rare (<0.6%). The vertical distribution of organisms in the sediment column is also typical of the deep sea. About 94% of the ostracods, 80% of the copepods and the nauplii, 52% of the annelids and 40% of the nematodes occur in the top 1 cm of sediment (L. D. Guidi-Guilvard unpubl. data), the layer most exposed to physical reworking. Thistle et al. (1991) reported that during benthic storms, near-bottom current speeds similar to those measured at the DYFAMED site in April 1996 ($\geq 20 \text{ cm s}^{-1}$) could erode as much as 1 cm of sediment. So, given the hydrodynamic context, it is not

surprising that the benthopelagic community was largely composed of the benthic taxa that tend to concentrate near the sediment surface.

Organism responses to environmental variability

The behaviour and reactions of deep-sea invertebrates to their environment are poorly known. The interpretation of our results is therefore partly based on what has previously been reported for their counterparts in shallow-water and laboratory studies. We found that the organisms collected 4 mab in the deep NW Mediterranean had both immediate and delayed responses to environmental variability (Table 5). These responses involved both passive and active behavioural reactions, as well as population growth.

Nematodes are typically weakly or non-swimming organisms (e.g. Shanks & Edmondson 1990). In the present study, they were eroded by strong bottom currents. Passive erosion of nematodes has previously been reported from both shallow-water (e.g. review by Palmer 1988, Guidi-Guilvard & Buscail 1995) and deep-sea (e.g. Aller 1989) environments. However, after having been eroded, the nematodes did not accumulate in the water column, which indicates rapid settlement. Hagerman & Rieger (1981) reported that nematodes had a particularly high settling velocity, probably because they cling to resuspended mineral particles. We found that nematodes also entered the water column after having colonized rebound aggregates, and in this case, did accumulate in the water column. Colonization of fresh phytodetrital aggregates by nematodes was observed on top of sediment cores from the deep NE Atlantic by Thiel et al. (1989), and Shanks & Edmondson (1990) noted that nematodes collected by sediment traps set ~ 12 mab in a shallow coastal bay were strongly associated with marine snow. According to these authors, marine snow is a sediment-like habitat suspended in the water column, in which nematodes reside (Shanks & Walters 1997). Despite their high abundance in the sediment, nematode fluxes were comparatively low at 4 mab (maximum of $8 \text{ ind. m}^{-2} \text{ d}^{-1}$). This value nevertheless is similar to that reported by Hagerman & Rieger (1981) from 1.5 mab in the shallow subtidal (i.e. $10 \text{ m}^{-2} \text{ d}^{-1}$). Among the numerous nematode species present in deep-sea sediments, probably only a few feed on fresh phytodetritus (see Iken et al. 2001), because most nematodes are linked to a short detrital or bacterial-based food chain within the sediment (Giere 2009). Moreover, they can avoid physical disturbance by moving deeper (e.g. Palmer 1988, Galéron et al. 2001).

Three harpacticoid species (SP2, SP4 and SP6) were also eroded by strong bottom currents. In contrast to

the nematodes that rapidly settled, SP4 and SP6 accumulated in the water column in the following weeks, as did SP3. All 4 harpacticoid species were either more abundant in 1996 than in 1997 (SP2 and SP3) or only present in 1996 (SP4 and SP6) when benthic storms occurred. Among these harpacticoids, only SP4 was found to colonize rebound aggregates, along with SP7, SP18 and SP20. The huntermanniid *Talpina* (SP7) has been observed in the sub-surface layers of sediment cores at the DYFAMED station (L. D. Guidi-Guilvard pers. obs.). Although its morphology shows strong adaptations for burrowing, our results suggest that it moves upwards in the sediment to feed on freshly deposited detritus. Our analyses show that only a few harpacticoid species found in the water column were associated with rebound aggregates. Likewise, Shanks & Edmondson (1990) reported that only 25% of the vertical flux of harpacticoids was due to individuals on marine snow. Most harpacticoids in the water column only 'visit' aggregates and actively swim away (Shanks & Walters 1997). In the present study, other invertebrates were found to colonize rebound aggregates, i.e. isopods, tanaids, gastropods and sea stars (the 3 latter were included in 'others'). Isopods (in Gage & Tyler 1991) and tanaids (in Higgins & Thiel 1988), which are detritivores, probably feed on freshly deposited aggregates, and phytodetritus was found in the gut of deep-sea asteroids (Thiel et al. 1989).

Freshly deposited aggregates were colonized by cumaceans (included in 'others'), ostracods and nauplii that have good swimming abilities. The 2 latter groups, along with SP5 (ectinosomatids) were also more abundant in the water column when particle flux (food for the benthos) was low. In coastal habitats, many benthic taxa that are good swimmers, e.g. amphipods, ostracods, polychaetes (Mees & Jones, 1997) and harpacticoid species (e.g. Bell et al. 1988) make excursions into the water column (emergence). Ectinosomatids are good swimmers, and within this harpacticoid family, many species have been identified as emergers, both in shallow water (e.g. Thistle 2003) and in the deep-sea (Thistle et al. 2007). In the present study, emergence of ostracods, nauplii and SP5 was probably a response to a local decline in food, a reason often invoked to explain harpacticoid emergence (e.g. Thistle et al. 2007). When low food conditions persisted, this response was enhanced for SP5, as well as for SP17 and SP22.

The 2 dominant copepod species, SP1 (*Tisbe*) and SP101 (*Barathricola*), also emerged. Both were present in trap samples and in sediment cores (L. D. Guidi-Guilvard pers. obs.). Following Thistle (2003) and Thistle & Sedlacek (2004), SP1 has the morphology of an emerger. We are not aware of equivalent rules for benthic cyclopoids, but the genus *Barathricola* is known to lead an epibenthic lifestyle (Boxshall & Halsey 2004).

These 2 species exhibited a clear population growth in response to food pulses, but SP101 responded faster than SP1. Development time found in the present study for SP1 is within the range of those reported for *Tisbe* species reared in the laboratory at equivalent temperatures (Hicks & Coull 1983). Such a lag response, although strongly expected in deep-sea benthic ecology studies, had never been shown before for meiobenthic copepods (review by Gooday 2002, Kalogeropoulou in press). Our statistical analyses furthermore showed that fluxes of annelids (essentially larval polychaetes) and SP4 also increased within the month following a food pulse. Similarly, Vanreusel et al. (2001) described a mass recruitment of opheliid polychaete juveniles in response to a phytodetrital input in the surface sediment of the deep NE Atlantic. In the present study, the increases in abundance were found in the water column, but they most certainly reflected those that were taking place in the benthos. At least for the 3 copepod species, the individuals could have emerged as a result of overcrowding, another reason often invoked in shallow-water studies to explain harpacticoid emergence. Walters (1991) observed that *Tisbe furcata* exhibited increased emergence frequency with increased harpacticoid density in the surface sediment. Reproductive activity has also been suggested as a possible explanation for emergence (e.g. Bell et al. 1988). In our trap samples, males of SP1 outnumbered females, which is in agreement with observations on shallow water harpacticoids. Immature individuals were moreover very abundant (copepodites accounted for 62% of the SP1 population). Because in harpacticoids, adult males mate with subadult females (Hicks & Coull 1983), the dominance of these 2 stages suggests that they were mating in the water column. However, from a study conducted on a shelf site, Thistle (2003) concluded that harpacticoids do not emerge primarily to find mates. Emergence behaviour would favour dispersal. The individuals collected at a site, especially high above the bottom like in the present study, do not originate from the local seabed. They come from some distance away from where they were advected in. As suggested by Bell et al. (1989), the co-occurrence of males and potential mates (copepodites) in the water column may be a strategy for re-establishment of a new population when the fauna actively re-enter the benthos on new grounds.

Concerning benthic cyclopoids, very little information is available in the literature. Most ecological studies are limited to planktonic species (e.g. Turner 1986, Uye & Sano 1998). The population of SP101 in our samples was dominated by females. This is in agreement with what is reported for planktonic cyclopoids. However, its behaviour and responses to environmental variability were closer to those of the harpacticoid SP1

than to those of SP102, a group of holoplanktonic cyclopoids. In the present study, SP102 was the only group that avoided rebound aggregates. Shanks & Edmondson (1990) also noted that cyclopoid copepods were weakly associated with marine snow. Although oncaeids have been observed feeding on these structures (e.g. Lampitt et al. 1993), they can also be carnivores (e.g. Turner 1986).

Our statistical analyses showed that ostracods, the canthocamptid SP10 and SP18 avoided resuspension by strong bottom flows. Moreover, the fluxes of the 2 latter species, along with those of 2 argestids (SP17 and SP22), another canthocamptid (SP8), SP1, SP101, calanoids, bivalves and annelids decreased in the following weeks. Many benthic organisms are capable of avoiding physical disturbance by moving deeper into the sediment (e.g. Galéron et al. 2001). This could explain our results for the benthic fauna, but for calanoids rough hydrodynamic conditions could have enhanced mortality. Most of the above benthic taxa were designated as emergers by our statistical analyses. Thus our results confirm Thistle's (2003) conclusion that energetic flows suppress emergence. This view is moreover supported by the strong interannual variation found in the present study, i.e. swimmer fluxes were much lower in the year of energetic flows. Of the 10 taxa for which the statistical analyses produced no information, 5 (i.e. the miraciids SP1121 and the argestids SP12, SP14, SP15 and SP19) were absent in that year, perhaps indicating that they, too, were emergers.

CONCLUSIONS

This investigation, based on an often overlooked sampling technique, produced the most comprehensive time series of hyperbenthos (meiobenthos) ever conducted in the deep sea. In a single study, most of the dispersal mechanisms, both by passive erosion/suspension or active emergence, previously reported for intertidal and shallow-water benthic organisms were encountered at 2347 m depth in the NW Mediterranean. The present study has led to new insights on the behaviour of deep-dwelling species, most of which have not yet been described, particularly within the typical deep-sea family Argestidae, some of which actively perform emergence. Some deep-sea species displayed a clear and rapid population growth in response to pulses of organic-rich detritus to the seafloor, a response that has never been shown before for deep-sea meiobenthic copepods. Moreover, our results underline the highly dynamic nature of deep-sea meiofauna populations, which could, in part, explain the (absence of) temporal variability generally

observed in sediment communities. Overall, the present study emphasizes the remarkable similarities in the general processes, whether physical or biological, between coastal and deep-sea environments.

Acknowledgements. This work was part of the French JGOFS program funded by the CNRS/INSU (France). L.G.G. thanks the officers and crews of RV 'Professeur George Petit' and 'Tethys II', as well as the technical team from EEP/LEP IFREMER for their assistance at sea. She gratefully acknowledges P. Crassous for performing the chemical analyses and P. Martinez Arbizu for advice on taxonomy.

LITERATURE CITED

- Aller JY (1989) Quantifying sediment disturbance by bottom currents and its effect on benthic communities in a deep-sea western boundary zone. *Deep-Sea Res Part A* 36: 901–934
- Bell SS, Hicks GRF, Walters K (1988) Active swimming in meiobenthic copepods of seagrass beds: geographic comparisons of abundance and reproduction characteristics. *Mar Biol* 98:351–358
- Bell SS, Hicks GRF, Walters K (1989) Experimental investigations of benthic reentry by migrating meiobenthic copepods. *J Exp Mar Biol Ecol* 130:291–303
- Billett DSM, Bett BJ, Reid WDK, Boorman B, Priede IG (in press) Long-term change in the abyssal NE Atlantic: the 'Amperima Event' revisited. *Deep Sea Res Part II* doi: 10.1016/j.dsr2.2009.02.001
- Boxshall GA, Halsey SH (2004) An introduction to copepod diversity. The Ray Society, London
- Bühning SI, Christiansen B (2001) Lipids in selected abyssal benthopelagic animals: links to the epipelagic zone? *Prog Oceanogr* 50:369–382
- Drazen JC, Baldwin RJ, Smith KL Jr (1998) Sediment community response to a temporally varying food supply at an abyssal station in the NE Pacific. *Deep-Sea Res Part II* 45: 893–913
- Gage JD, Tyler PA (1991) *Deep-sea biology: a natural history of organisms at the deep-sea floor*. Cambridge University Press, Cambridge
- Galéron J, Sibuet M, Vanreusel A, Mackenzie K, Gooday AJ, Dinet A, Wolff GA (2001) Temporal patterns among meiofauna and macrofauna taxa related to changes in sediment geochemistry at an abyssal NE Atlantic site. *Prog Oceanogr* 50:303–324
- Gardner WD, Richardson MJ (1992) Particle export and resuspension fluxes in the western north Atlantic. In: Rowe GT, Pariente V (eds) *Deep-sea food chains and the global carbon cycle*. Kluwer, Dordrecht, p 339–364
- Giere O (2009) *Meiobenthology. The microscopic fauna in aquatic sediments*, 2nd edn. Springer, Berlin
- Gooday AJ (1988) A response by benthic foraminifera to phytodetritus deposition in the deep sea. *Nature* 332:70–73
- Gooday AJ (2002) Biological responses to seasonally varying fluxes of organic matter to the ocean floor: a review. *J Oceanogr* 58:305–332
- Guidi-Guilvard LD (2002) DYFAMED-BENTHOS, a long time-series benthic survey at 2347-m depth in the NW Mediterranean: general introduction. *Deep-Sea Res Part II* 49:2183–2193
- Guidi-Guilvard LD, Buscail R (1995) Seasonal survey of meta-zoan meiofauna and surface sediment organics in a non-

- tidal turbulent sublittoral prodelta (northwestern Mediterranean). *Cont Shelf Res* 15:633–653
- Hagerman GM, Rieger RM (1981) Dispersal of benthic meiofauna by wave and current action in Bogue Sound, North Carolina, USA. *PSZNI: Mar Ecol* 2:245–270
- Hargrave BT, von Bodungen B, Conover RJ, Fraser AJ, Phillips G, Vass WP (1989) Seasonal changes in sedimentation of particulate matter and lipid content of zooplankton collected by sediment trap in the Arctic Ocean off Axel Heiberg Island. *Polar Biol* 9:467–475
- Hicks GRF, Coull BC (1983) The ecology of marine meiobenthic harpacticoid copepods. *Oceanogr Mar Biol Annu Rev* 21:67–175
- Higgins RP, Thiel H (1988) Introduction to the study of meiofauna. The Smithsonian Institution Press, Washington, DC
- Huys R, Gee JM, Moore CG, Hamond R (1996) Marine and brackish water harpacticoid copepods. Part 1. In: Barnes RSK, Crothers JH (eds) *Synopses of the British fauna*, No. 51. Field Studies Council, Shrewsbury
- Iken K, Brey T, Wand U, Voigt J, Jungsham P (2001) Food web structure of the benthic community at the Porcupine Abyssal plain (NE Atlantic): a stable isotope analysis. *Prog Oceanogr* 50:383–405
- Kalogeropoulou V, Bett BJ, Gooday AJ, Lampadariou N, Martinez Arbizu P, Vanreusel A (in press) Temporal changes (1989–1999) in deep-sea metazoan meiofaunal assemblages on the Porcupine Abyssal Plain, NE Atlantic. *Deep-Sea Res Part II* doi:10.1016/j.dsr2.2009.02.002
- Karl DM, Knauer GA (1989) Swimmers: a recapitulation of the problem and a potential solution. *Oceanography* 2:32–35
- Karl DM, Bates N, Emerson S, Harrison PJ and others (2003) Temporal studies of biogeochemical processes determined from ocean time-series observations during the JGOFS Era. In: Fasham MJR (ed) *Ocean biogeochemistry. The role of the ocean carbon cycle in global change*. Springer, Berlin, p 239–267
- Khripounoff A, Vangriesheim A, Crassous P (1998) Vertical and temporal variations of particle fluxes in the deep tropical Atlantic. *Deep-Sea Res Part I* 45:193–216
- Lampitt RS (1985) Evidence for the seasonal deposition of detritus to the deep-sea floor and its subsequent resuspension. *Deep-Sea Res Part A* 32:885–897
- Lampitt RS, Wishner KF, Turley CM, Angel MV (1993) Marine snow studies in the Northeast Atlantic Ocean: distribution, composition and role as a food source for migrating plankton. *Mar Biol* 116:689–702
- Lampitt RS, Newton PP, Jickels TD, Thomson J, King P (2000) Near-bottom particle flux in the abyssal northeast Atlantic. *Deep-Sea Res Part II* 47:2051–2071
- Lampitt RS, Bett BJ, Kiriakoulakis K, Popova EE, Ragueneau O, Vangriesheim A, Wolff GA (2001) Material supply to the abyssal seafloor in the Northeast Atlantic. *Prog Oceanogr* 50:27–63
- Lochte K (1992) Bacterial standing stock and consumption of organic carbon in the benthic boundary layer of the abyssal North Atlantic. In: Rowe GT, Pariente V (eds) *Deep-sea food chains and the global carbon cycle*. Kluwer, Dordrecht, p 1–10
- Marty JC (2002) The DYFAMED time-series program (French-JGOFS). *Deep-Sea Res Part II* 49:1963–1964
- Mees J, Jones MB (1997) The hyperbenthos. *Oceanogr Mar Biol Annu Rev* 35:221–255
- Palmer MA (1988) Dispersal of marine meiofauna: a review and conceptual model explaining passive transport and active emergence with implications for recruitment. *Mar Ecol Prog Ser* 48:81–91
- Rakotomalala R (2005) TANAGRA: un logiciel gratuit pour l'enseignement et la recherche. Actes des cinquièmes journées Extraction et Gestion des Connaissances EGC'2005, Rev Nouvel Technol Inform (E-3) 2:697–702
- Seiler D, Brandt A (1997) Seasonal occurrence of planktic crustacea in sediment trap samples at three depth horizons in the Greenland Sea. *Polar Biol* 17:337–349
- Shanks AL, Edmondson EW (1990) The vertical flux of metazoans (holoplankton, meiofauna, and larval invertebrates) due to their association with marine snow. *Limnol Oceanogr* 35:455–463
- Shanks AL, Walters K (1997) Holoplankton, meroplankton, and meiofauna associated with marine snow. *Mar Ecol Prog Ser* 156:75–86
- Smith KL Jr, Carlucci AF, Jahnke RA, Craven DB (1987) Organic carbon mineralization in the Santa Catalina Basin: benthic boundary layer metabolism. *Deep-Sea Res Part A* 34:185–211
- Smith KL Jr, Baldwin RJ, Karl DM, Boetius A (2002) Benthic community responses to pulses in pelagic food supply: North Pacific Subtropical Gyre. *Deep-Sea Res Part I* 49:971–990
- Soetaert K, Herman PMJ, Middelburg JJ (1996) Dynamic response of deep-sea sediments to seasonal variations: a model. *Limnol Oceanogr* 41:1651–1668
- Steinberg DK, Pilskaln CH, Silver MW (1998) Contribution of zooplankton associated with detritus to sediment trap 'swimmer' carbon in Monterey Bay, California, USA. *Mar Ecol Prog Ser* 164:157–166
- Thiel H, Pfannkuche O, Schriever G, Lochte K and others (1989) Phytodetritus on the deep-sea floor in a central ocean region of the Northeast Atlantic. *Biol Oceanogr* 6:203–239
- Thistle D (2003) Harpacticoid copepod emergence at a shelf site in summer and winter: implications for hydrodynamic and mating hypotheses. *Mar Ecol Prog Ser* 248:177–185
- Thistle D, Sedlacek L (2004) Emergent and non-emergent species of harpacticoid copepods can be recognized morphologically. *Mar Ecol Prog Ser* 266:195–200
- Thistle D, Ertman SC, Fauchald K (1991) The fauna of the HEBBLE site: patterns in standing stock and sediment-dynamic effects. *Mar Geol* 99:413–422
- Thistle D, Sedlacek L, Carman KR, Fleeger JW, Barry JP (2007) Emergence in the deep sea: evidence from harpacticoid copepods. *Deep-Sea Res Part I* 54:1008–1014
- Turner JT (1986) Zooplankton feeding ecology: contents of fecal pellets of the cyclopoid copepods *Oncaea venusta*, *Corycaeus mazonicus*, *Oithona plumifera*, and *O. simplex* from the northern Gulf of Mexico. *PSZNI: Mar Ecol* 7: 289–372
- Uye S, Sano K (1998) Seasonal variations in biomass, growth rate and production rate of the small cyclopoid copepod *Oithona davisae* in a temperate eutrophic inlet. *Mar Ecol Prog Ser* 163:37–44
- Vanreusel A, Cosson-Sarradin N, Gooday AJ, Paterson GJL, Galéron J, Sibuet M, Vincx M (2001) Evidence for episodic recruitment in a small opheleid polychaete species from the abyssal NE Atlantic. *Prog Oceanogr* 50:285–301
- Walters K (1991) Influences of abundance, behavior, species composition, and ontogenetic stage on active emergence of meiobenthic copepods in subtropical habitats. *Mar Biol* 108:207–215
- Willis K, Cottier F, Kwasniewski S, Wold A, Falk-Petersen S (2006) The influence of advection on zooplankton community composition in an Arctic fjord (Kongsfjorden, Svalbard). *J Mar Syst* 61:39–54
- Wishner KF (1980) Aspects of the community ecology of deep-sea, benthopelagic plankton, with special attention to gymnopleid copepods. *Mar Biol* 60:179–187



α -, β -, γ -, δ - and ϵ -diversity of deep-sea nematodes in canyons and open slopes of Northeast Atlantic and Mediterranean margins

R. Danovaro*, S. Bianchelli, C. Gambi, M. Mea, D. Zeppilli

Dipartimento di Scienze del Mare, Università Politecnica delle Marche, Via Brecce Bianche, 60131 Ancona, Italy

ABSTRACT: Meiofaunal biodiversity, with a special focus on nematodes, was investigated in 6 submarine canyons and 5 adjacent open slopes along bathymetric gradients (from ca. 200 to 5000 m depth) from 3 deep-sea regions (northeastern Atlantic, western and central Mediterranean) spanning >2500 km and across a wide gradient of trophic and physicochemical conditions. The analysis of local (α) diversity at equal depths showed the presence of similar values in the NE Atlantic and Mediterranean deep-sea sediments. The comparison of the α diversity between different deep-sea habitats (canyons versus adjacent open slopes) revealed the lack of significant differences in species richness in most of the investigated systems. However, the analysis of nematode species composition showed the presence of major differences among different sampling depths (i.e. 500 versus 1000 versus 2000 m depth) and habitats. Turnover (β) diversity was high in all of the investigated deep-sea systems, but was higher in the NE Atlantic (87%) than in the Mediterranean margins (range 51 to 60%), resulting in higher values of regional (γ) diversity in the Atlantic margin. Turnover diversity among regions (δ diversity) was highest (~91%) between the NE Atlantic and western Mediterranean, but still extremely high between the western and central Mediterranean margins (~80%), thus leading to similar values of biogeographical diversity (ϵ) in the NE Atlantic and Mediterranean deep biogeographical provinces. The results suggest that biogeographic differences in deep-sea species composition are related to differences in β and δ diversity and not to differences in α diversity, and that the analysis of the factors driving β diversity are crucial to understand the spatial patterns of biodiversity in the deep sea.

KEY WORDS: Deep-sea nematodes · Biogeography · Canyons · Open slopes · Mediterranean Sea · Atlantic Ocean

Resale or republication not permitted without written consent of the publisher

INTRODUCTION

Deep-sea sediments cover more than 65% of the Earth's surface. Research conducted in the last 2 decades has completely changed our perception of the characteristics and functioning of these ecosystems (Gage & Tyler 1991). We know now that deep-sea ecosystems can be highly complex, diverse and characterized by high spatial and temporal variability (Rex et al. 2001, 2005, Gaston 2000, Lambshead et al. 2000, Gage 2004, Danovaro et al. 2008a), but the knowledge of the factors controlling bathymetric, latitudinal and longi-

tudinal patterns is still very poor (Snelgrove & Smith 2002, Danovaro et al. 2004, Canals et al. 2006, Danovaro et al. 2008a). Among these factors, spatial heterogeneity of the deep-sea benthic habitats can significantly influence several biological variables including local (α) and turnover (β) biodiversity.

Continental margins are extremely heterogeneous, due to their high topographic complexity, and characterized by the presence of different habitats (such as canyons, open slopes and landslides; Canals et al. 2004, Weaver et al. 2004). Deep-sea topographic heterogeneity can affect regional hydrodynamics with

*Email: r.danovaro@univpm.it

important effects on the entire food chain, from phytoplankton to marine mammals (Gage et al. 1995, Vetter & Dayton 1998, Duineveld et al. 2001). Deep-sea canyons, for instance, are important pathways for the transport of organic carbon to the ocean's interior, and fast-track corridors for material rapidly transported from the land to the deep sea (Canals et al. 2006). The peculiar topographic and hydrodynamic features of deep-sea canyons (including bottom currents, sedimentation rates and vertical fluxes) contribute to create peculiar benthic habitats (Gili et al. 1999, Yoklavich et al. 1999), which support high rates of oxygen consumption, high values of benthic faunal biomass and diversity (Greene et al. 1988, Gage & Tyler 1991, Vetter 1995, Accornero et al. 2003). Moreover, these systems display a high level of endemism, possibly linked to conditions that promote speciation (Wilson & Hessler 1987, Jablonski & Bottjer 1990).

The high values and peculiarity of the biodiversity inhabiting canyons has led to identification of these systems as hot spots of deep-sea biodiversity (de Boveé et al. 1990, Soetaert & Heip 1995, Danovaro et al. 1999, Baguley et al. 2006, Garcia et al. 2007), but comprehensive comparisons among canyons and adjacent slopes under different regional settings are scant (Garcia et al. 2007, Van Gaever et al. 2009).

Meiofauna are the numerically dominant metazoan components of the deep-sea benthos (Vincx et al. 1994). Nematodes are the most abundant metazoan meiofaunal taxon, and their dominance increases with water depth (up to >90%; Thiel 1975, Heip et al. 1985, Cook et al. 2000, Lamshead & Schalk 2001, Danovaro et al. 2002). Nematodes are ubiquitous in all deep-sea regions and are characterized by potentially high species richness (Jensen 1988, Tietjen 1992). They play an important role in the benthic trophodynamics and their feeding ecology can be inferred from the morphology of their mouth cavity (Wieser 1953, Jensen 1987, Soetaert & Heip 1995), thus offering the opportunity to examine patterns of structural and functional (trophic) diversity in the deep sea (Danovaro et al. 2008b).

In the present study, we compared meiofaunal diversity (higher taxa) and nematode species richness from 3 deep-sea regions: the northeastern Atlantic Ocean and the western and central Mediterranean basin, characterized by different topographic settings, productivity and physicochemical conditions. We also investigated bathymetric patterns of biodiversity and compared the species richness (α -diversity) and turnover in species composition (β -diversity) of deep-sea canyons and adjacent open slopes in order to identify factors controlling deep-sea biodiversity along continental margins and the role of these in promoting regional (γ) diversity.

MATERIALS AND METHODS

Sampling. Samples were collected from the northeastern Atlantic Ocean (Portuguese margin) and the western (Catalan margin) and central (South Adriatic margin) Mediterranean Sea (Fig. 1). Overall, 6 deep-sea canyons and 5 adjacent open slopes were investigated. The same sampling strategy was utilised in all regions: sediment samples were collected from 44 stations at standard water depths, along the main axis of the canyons and the adjacent open slopes at standard depth (ca. 200, 500, 1000, 2000, 3000, 4000 and 5000 m depth, depending on the highest depth of the slope in each region). In the northeastern Atlantic, sediment samples were collected in September 2006 from 21 stations (at depths ranging from 416 to 4987 m) using the RV 'Pelagia'. Two canyons (the Nazaré and Cascais) and 2 adjacent open slopes (hereafter, the N and S Portuguese slopes) were investigated. In the western Mediterranean (Catalan margin), sediment samples were collected from 12 stations (at depths ranging from 334 to 2342 m) in October 2005 using the RV 'Universitat'. Two canyons (the Cap de Creus/Sete and Lacaze-Duthiers) and 2 adjacent open slopes (hereafter the N and S Catalan slopes) were compared. In the central Mediterranean (South Adriatic margin), sediment samples were collected in May 2006 using the RV 'Urania' from 11 stations (depths ranging from 196 to 908 m) in 2 canyons (canyons B and C) and adjacent open slope (hereafter the S Adriatic slope). In all deep-sea regions, sediment samples were collected using a multiple corer and/or a NIOZ-type box corer allowing the recovery of virtually undisturbed sediment samples. The 2 sampling devices proved to be equivalent in the sampling of sedimentary and biotic variables (Danovaro et al. 1998). At all sampling stations, 3 sediment cores (internal diameter 3.6 cm) from the independent deployments (whenever possible) were analysed for meiofaunal parameters (0 to 15 cm) and nematode diversity (0 to 1 cm). Sediment samples for organic matter analysis (the top 1 cm from 3 different cores) were preserved at -20°C until analysis in the laboratory.

Meiofaunal analyses. For meiofaunal extraction, sediment samples were sieved through 1000 μm mesh, and a 20 μm mesh was used to retain the smallest organisms. The fraction remaining on the latter sieve was resuspended and centrifuged 3 times with Ludox HS40 (density 1.31 g cm^{-3}) according to Heip et al. (1985). All meiobenthic animals were counted under a stereomicroscope and classified per higher taxon after staining with Rose Bengal (0.5 g l^{-1}). All animals except for nematodes were identified to higher taxa (sensu De Troch et al. 2006).

Nematode diversity. For nematode diversity analysis, 100 nematodes for each of the 3 replicates (or all nematodes when the abundance was lower than 100

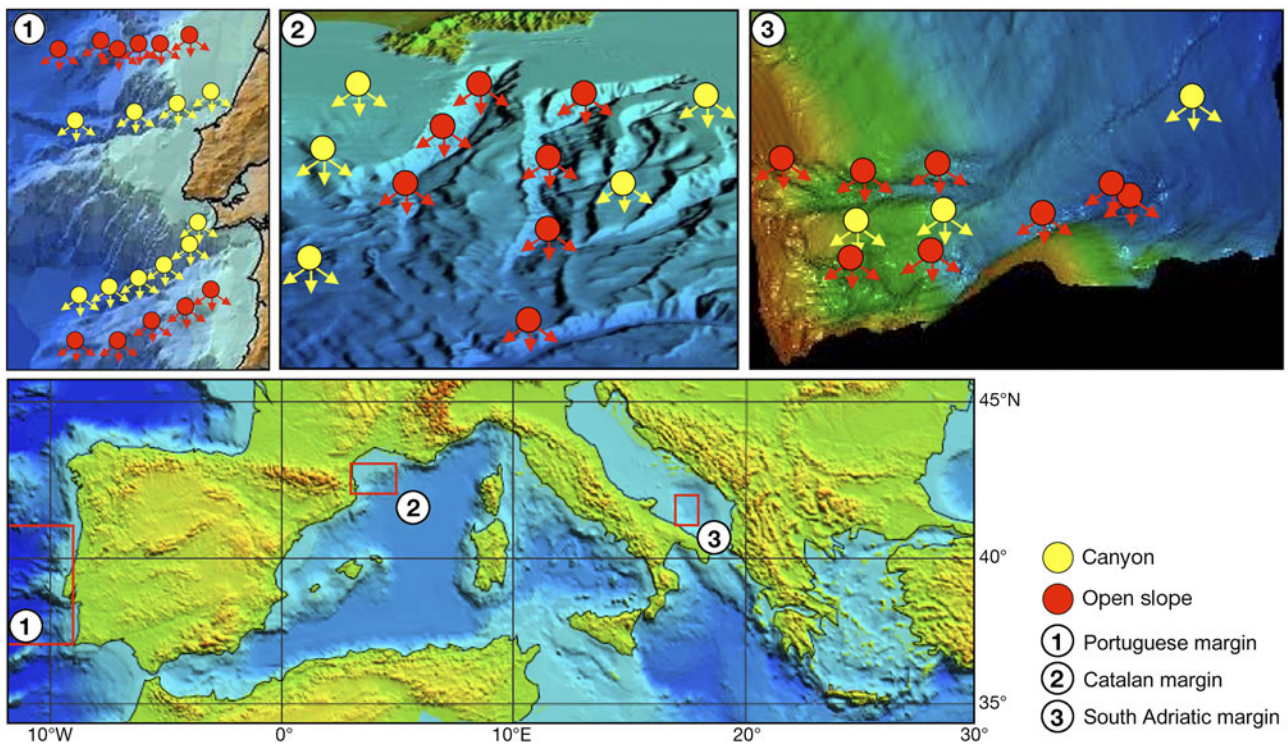

Fig. 1. Sampling areas and station locations. Arrows represent the 3 deployments performed at each station. Black in Panel 3: no bathymetric data

specimens per sample) were withdrawn and mounted on slides following the formalin-ethanol-glycerol technique described by Seinhorst (1959) to prevent dehydration. Nematodes were identified to species level (indicated as sp1, sp2, sp3, etc., due to the presence of several unknown deep-sea species) according to Platt & Warwick (1983, 1988), Warwick et al. (1998) and the recent literature dealing with new nematode genera and species (NeMys database, Deprez et al. 2005).

Nematode diversity was estimated using species richness (SR), defined as the total number of species identified at each station. Since species richness is strongly affected by the sample size, in order to standardise the values of nematode diversity, the expected number of species, $ES(x)$, was considered. At each site, the species abundance data were converted into rarefaction diversity indices (Sanders 1968, as modified by Hurlbert 1971). The expected number of species for a theoretical sample of 100 specimens, $ES(100)$, was selected to facilitate comparison of diversities from different regions. Species diversity (H' , using log-base 2, H'^2) was measured by the Shannon-Wiener information function and species evenness was measured using J' (Pielou 1975). All indices reported above were calculated using PRIMER v5 (Clarke 1993). All diversity indices were calculated from the sum of the individuals of the 3 replicates of each sampling station.

We measured point, local (α), regional (γ) and biogeographical (ϵ) diversity; as inventory diversity measures they provide information on the species richness in an area at different spatial scales. All of these measures are expressed as nematode species abundance (Gray 2000). We also measured turnover diversity among sample diversity measures (β diversity) and turnover diversity among γ diversity measures (δ diversity) as diversity-differentiation measures, as they provide indications of the change in species composition among samples (β diversity) and regions (δ diversity). β and δ diversity were measured using similarity percentage (SIMPER) analyses and expressed as percentage of dissimilarity, based on a Bray-Curtis similarity matrix (Gray 2000).

The trophic composition of nematode assemblages was defined according to Wieser (1953). Nematodes were divided into 4 original groups as follows: (1A) no buccal cavity or a fine tubular one, selective (bacterial) feeders; (1B) large but unarmed buccal cavity, non-selective deposit feeders; (2A) buccal cavity with scraping tooth or teeth, epistrate or epigrowth (diatom) feeders; (2B) buccal cavity with large jaws, predators/omnivores. Moens & Vincx (1997) and Moens et al. (1999) proposed a modified feeding-type classification based on: (1) microvores; (2) ciliate feeders; (3) deposit feeders sensu stricto; (4) epigrowth feeders; (5) facultative predators and (6) predators. However, in the present study, Wieser's (1953) classification was preferred because it

is still widely used and no feeding-type information was available for most genera encountered in deep-sea systems in order to use the classification by Moens & Vincx (1997) and Moens et al. (1999).

The index of trophic diversity (ITD) was calculated as $1 - ITD$, where $ITD = g_1^2 + g_2^2 + g_3^2 \dots + g_n^2$, where g is the relative contribution of each trophic group to the total number of individuals and n is the number of trophic groups (Gambi et al. 2003). For $n = 4$ (as in the present study) $1 - ITD$ ranges from 0.00 to 0.75.

To identify colonization strategies of nematodes, the maturity index (MI) was calculated according to the weighted mean of the individual genus scores: $MI = \sum v(i)f(i)$, where v is the $c - p$ value (colonisers – persisters) of genus i (as given in the Appendix of Bongers et al. 1991) and $f(i)$ is the frequency of that genus.

Statistical analyses. To test for bathymetric changes in the richness of higher meiofaunal taxa and nematode diversity indices in canyon and open slope sediments, a 1-way ANOVA was carried out for all of the measured indices separately for all of the canyons and open slopes, using stations (sampling depth) as random factors. When significant differences were encountered, a Student-Newman-Keuls (SNK) post hoc comparison test (at $\alpha = 0.05$) was also carried out to ascertain in which transect values significantly changed with water depth.

PRIMER v5 software (Clarke 1993) was used to calculate Bray-Curtis similarities between all sampling sites. The obtained similarity matrix was used to produce a non-metric multidimensional scaling (NMDS) 2-dimensional plot. SIMPER analyses (based on the Bray-Curtis similarity index) were performed to estimate the β and δ diversity (i.e. turnover diversity estimated as % Bray-Curtis dissimilarity; Gray 2000) in meiofaunal taxonomic composition and nematode species composition between sampling depths within the same transect, between canyons and open slopes within the same region and among different regions (PRIMER v5; Clarke 1993). Analysis of similarities (ANOSIM) was performed to test for the presence of statistical differences in meiofaunal taxonomic composition and nematode species composition between sampling depths within the same transect, between canyons and open slopes within the same region and among different regions (PRIMER v5; Clarke 1993). All absolute data were presence/absence transformed prior to the analysis.

In order to assess how well the environmental constraints explained changes in biodiversity indices, non-parametric multivariate multiple regression analyses based on Bray-Curtis distances were carried out using the routine DISTLM forward (McArdle & Anderson 2001). The forward selection of the predictor variables was carried out with tests by permutation; p -values were obtained using 4999 permutations of raw data for the marginal tests (tests of individual variables), while

for all of the conditional tests, the routine used 4999 permutations of residuals under a reduced model. We used water depth, bottom temperature, bottom salinity and sediment grain size as environmental parameters; phytopigment and biopolymeric C concentrations as indicators of the amount of trophic resources; and phytopigment to biopolymeric C ratio, protein to biopolymeric C ratio and carbohydrate to biopolymeric C ratio as indicators of the quality of trophic resources (for more details see Pusceddu et al. in press).

RESULTS

Bathymetric gradients of meiofaunal biodiversity along continental margins

Meiofaunal higher taxa richness and nematode diversity (expressed as SR, ES(100), H^2 , J' , $1 - ITD$ and MI) are reported in Table 1. SR of nematodes ranged between 29 and 111 in the Portuguese margins, between 57 and 81 in the Catalan margins and between 15 and 82 in the South Adriatic margin. Significant changes in nematode diversity with increasing water depth were observed only in ~50 % of the investigated systems, but the bathymetric patterns were not consistent between habitats (canyons versus slopes) or among regions (Table 2). In the S Portuguese and N Catalan slopes and the Cap de Creus/Sete and S Adriatic B canyons, the diversity indices decreased with increasing water depth, while they increased in the S Catalan slope and the Nazaré and S Adriatic C canyons. Finally, no significant bathymetric differences were observed in any of the other transects.

The SIMPER analysis, carried out for each transect, revealed that the dissimilarity among stations (β diversity) ranged from 32 to 57 % for meiofaunal higher taxa, and from 51 to 80 % for nematode species composition (Table 3). The ANOSIM analysis on each transect revealed the lack of significant differences in meiofaunal taxa composition among different depths ($p > 0.05$, ns; Table 3), but the presence of significant differences in terms of nematode species composition in almost all of the transects ($p < 0.01$; Table 3).

$1 - ITD$ (0.28 to 0.74) and MI (2.13 to 3.21) did not display clear spatial patterns along the bathymetric gradients in each region (Table 1).

Richness of meiofaunal higher taxa and nematode biodiversity

Canyons and open slopes

At approximately equal depths, the richness of meiofaunal higher taxa and nematode species richness did

Table 1. Richness of meiofaunal higher taxa and nematode diversity indices in the study regions. SR: species richness; ES(100): expected species number for 100 individuals; H'^2 : Shannon's index; J' : species evenness; 1 – ITD: index of trophic diversity; MI: maturity index

Transect	Depth (m)	Richness of meiofaunal higher taxa	SR	ES(100)	H'^2	J'	1 – ITD	MI
Portuguese margin								
Northern open slope	416	8	111	65.45	41.11	0.94	0.71	2.69
	959	13	95	58.10	36.64	0.92	0.66	2.69
	1463	8	75	63.31	35.11	0.95	0.71	2.81
	3475	9	102	63.30	39.22	0.94	0.72	2.71
	3981	7	94	55.63	35.43	0.91	0.69	2.66
	4902	7	93	54.80	34.55	0.90	0.72	2.75
Nazaré canyon	458	10	29	18.65	9.61	0.64	0.28	2.13
	897	7	50	33.46	22.70	0.84	0.74	2.87
	3231	8	50	33.90	21.75	0.83	0.69	2.69
	4363	5	49	35.30	23.15	0.86	0.71	2.80
Cascais	445	10	49	33.86	23.21	0.86	0.63	2.43
	1021	15	41	27.77	18.17	0.80	0.64	2.72
	2100	10	54	35.66	24.23	0.86	0.73	2.72
	2975	7	55	36.42	23.76	0.84	0.68	2.96
	3914	9	60	37.57	23.66	0.82	0.66	2.77
	4689	4	42	32.28	21.66	0.86	0.72	3.00
Southern open slope	1002	11	76	48.18	30.47	0.88	0.62	2.74
	2130	12	99	57.36	37.13	0.92	0.61	2.67
	2908	7	72	50.35	32.17	0.92	0.62	2.77
	3958	10	86	53.84	34.39	0.91	0.68	2.72
	4987	8	86	52.62	33.71	0.90	0.70	2.78
Catalan margin								
Northern open slope	334	14	80	49.18	33.30	0.91	0.71	2.78
	1022	6	66	43.00	29.36	0.90	0.73	2.90
Lacaze-Duthiers canyon	434	15	61	39.63	26.66	0.87	0.69	2.61
	990	14	62	39.14	25.98	0.86	0.69	2.60
	1497	9	64	43.25	27.77	0.88	0.71	2.78
Cap de Creus/ Sete canyon	960	8	81	47.56	31.45	0.88	0.71	3.04
	1434	7	59	36.86	24.13	0.84	0.66	2.69
	1874	5	57	43.14	27.38	0.90	0.71	2.82
	2342	10	70	44.02	29.91	0.89	0.70	2.97
Southern open slope	398	10	63	41.00	27.19	0.87	0.68	2.82
	985	11	68	42.33	27.64	0.86	0.69	2.73
	1887	10	80	48.53	32.73	0.90	0.70	2.93
South Adriatic margin								
Canyon B	370	5	65	48.69	29.81	0.91	0.71	3.02
	446	8	56	33.33	20.04	0.77	0.54	3.21
	590	7	56	40.85	26.82	0.89	0.65	2.77
Open slope	196	7	75	49.51	31.43	0.90	0.70	2.92
	406	7	57	39.19	25.50	0.87	0.72	2.63
	908	6	62	39.72	23.46	0.81	0.61	2.83
Canyon C	341	6	15	15.00	11.81	0.88	0.60	3.39
	435	7	47	39.16	25.16	0.90	0.67	2.69
	593	8	59	41.59	27.67	0.89	0.69	2.95
	618	7	54	34.55	21.62	0.81	0.59	2.90
	721	12	82	50.38	32.23	0.89	0.66	2.93

not display significant differences between canyons and adjacent open slopes within the same region (Table 1). The SIMPER and ANOSIM analyses, performed at 500, 1000 and 2000 m depths to assess the dissimilarity in meiofaunal higher taxa and nematode

species composition between canyons and open slopes (β diversity), are reported in Table 4. At all sampling depths, the dissimilarity between canyons and open slopes was extremely high—on average 87% in the Portuguese margin, 51% in the Catalan margin and 60% in the South Adriatic margin—whilst the dissimilarity in terms of meiofaunal higher taxa was much lower (Table 4).

The ANOSIM analysis between canyons and open slopes revealed the lack of significant differences in the meiofaunal taxa composition within each investigated region at equal depths (i.e. 500, 1000 and 2000 m; ANOSIM, $p > 0.05$, ns; Table 4). Conversely, the ANOSIM analysis revealed significant differences between canyons and open slopes in the nematode species composition only in the Portuguese margin (ANOSIM, $p < 0.01$; Table 4).

Deep-sea regions

The richness of meiofaunal higher taxa and nematode species richness, on average, slightly decreased from the northeastern Atlantic to the central Mediterranean margin (Fig. 2). The analysis of meiofaunal assemblage composition confirmed the dominance of nematodes, copepods and polychaetes at all of the investigated deep-sea regions, but nematode species composition demonstrated the dominance of different species in different regions (Table 5 & Appendix 1).

At each water depth (i.e. 500, 1000 and 2000 m), significant differences among different regions were observed in terms of meiofaunal higher taxa and nematode species composition (ANOSIM, $p < 0.01$; Table 6). The dissimilarity of nematode species composition among different deep-sea regions (δ diversity), measured using

the SIMPER analysis, was extremely high even when the analysis was restricted to equal water depths (i.e. 500, 1000 and 2000 m). The dissimilarity in species composition between the Portuguese margin and the Mediterranean regions was, on average, 90% and

Table 2. 1-way ANOVA carried out separately in all bathymetric transects testing for changes along a water depth gradient. SR: species richness; ES(100): expected species number for 100 individuals; H^2 : Shannon's index; J' : species evenness; SNK: Student-Newman-Keuls test; *** $p < 0.001$; ** $p < 0.01$; * $p < 0.05$; ns: not significant. +: increasing values with increasing water column depth; -: decreasing values with increasing water column depth

Transect	Richness of higher taxa			SR			ES(100)			H^2			J'		
	F	p	SNK	F	p	SNK	F	p	SNK	F	p	SNK	F	p	SNK
Portuguese margin															
N Portuguese slope	0.62	ns	ns	0.39	ns	ns	0.39	ns	ns	0.75	ns	ns	1.68	ns	ns
Nazaré canyon	2.21	ns	ns	13.87	***	+	13.87	***	+	53.56	***	+	24.84	***	+
Cascais canyon	2.46	ns	ns	1.94	ns	ns	1.97	ns	ns	1.83	ns	ns	1.60	ns	ns
Catalan margin															
S Portuguese slope	6.85	***	-	2.93	ns	ns	2.93	ns	ns	1.72	ns	ns	0.57	ns	ns
N Catalan slope	57.80	***	-	7.90	*	-	5.22	ns	ns	2.63	ns	ns	0.23	ns	ns
Lacaze-Duthiers canyon	3.82	ns	ns	0.57	ns	ns	0.52	ns	ns	0.41	ns	ns	0.47	ns	ns
Cap de Creus/Sete canyon	2.91	ns	ns	10.38	***	-	10.40	**	-	10.38	**	-	6.19	*	-
S Catalan slope	0.60	ns	ns	5.73	*	+	6.22	*	+	2.91	ns	ns	1.37	ns	ns
South Atlantic margin															
Canyon B	1.82	ns	ns	6.93	*	-	6.93	*	-	6.73	*	-	6.28	*	-
S Adriatic slope	1.95	ns	ns	0.85	ns	ns	0.85	ns	ns	1.32	ns	ns	2.05	ns	ns
Canyon C	14.56	***	+	14.58	***	+	14.58	***	+	14.09	***	+	1.54	ns	+

Table 3. ANOSIM and SIMPER to test for differences in meiofaunal higher taxonomic composition and nematode species composition along a bathymetric gradient in each transect. Avg. diss.: average dissimilarity; *** $p < 0.001$; ns: not significant

Transect	Meiofauna			Nematode		
	ANOSIM R	SIMPER p	Avg. diss. (%)	ANOSIM R	SIMPER p	Avg. diss. (%)
Portuguese margin						
N Portuguese slope	0.13	ns	40.18	0.09	ns	70.97
Nazaré	0.34	ns	27.38	0.39	***	79.83
Cascais	0.35	ns	34.71	0.28	ns	58.74
S Portuguese slope	0.16	ns	36.89	0.27	***	63.62
Catalan margin						
N Catalan slope	1.00	***	43.63	0.54	***	51.57
Lacaze-Duthiers	0.26	ns	42.73	0.28	ns	56.79
Cap de Creus/Sete	0.31	ns	36.74	0.61	***	55.43
S Catalan slope	0.74	***	43.70	0.92	***	51.31
Catalan margin						
B canyon	0.11	ns	56.54	0.63	***	55.74
S Adriatic slope	0.07	ns	34.83	0.87	***	70.43
C canyon	0.22	ns	32.30	0.62	***	67.10

between the western and central Mediterranean ~83%, whereas the dissimilarity of higher taxa composition was again lower (Table 6). The NMDS ordination plot based on these results pointed out that differences among deep-sea regions were more important than differences between habitats (e.g. canyon versus slope; Fig. 3).

The patterns of nematode species richness at larger spatial scales (i.e. habitat and regional scale) including all sampling depths are illustrated in Fig. 4a–c. The

habitat diversity was similar in open slopes and canyons of the Mediterranean regions (Fig. 4a), but not in the Atlantic margin, where it was higher in the open slopes. Regional diversity (γ -diversity, Fig. 4b) was higher in the Portuguese margin than the other 2 investigated regions. Overall, nematode ϵ diversity (biogeographical diversity) was higher in the northeastern Atlantic than in the Mediterranean Sea (Fig. 4c). The results of the multivariate multiple regression analyses (DISTML) carried out using the biodiversity indices from the entire data set revealed that most of the variance could be explained by temperature, bottom salinity, grain size and a combination of pigment, proteins and biopolymeric C concentration ('All sites' in Table 7).

DISCUSSION

Bathymetric gradients in α diversity in deep-sea margins

Several studies have hypothesised that different factors, such as habitat heterogeneity (Levin et al. 2001, Vanhove et al. 2004) and changes in food availability and supply (Lambshhead et al. 2000, 2002), can influence deep-sea biodiversity distribution. Since food in-

Table 4. ANOSIM and SIMPER to test for differences in meiofaunal higher taxonomic composition and nematode species composition at each selected water column depth (i.e. 500, 1000 and 2000 m) between canyons and open slopes within the same region. Avg. diss.: average dissimilarity; *** $p < 0.001$; ns: not significant; na: not available

Depth and transect	Meiofaunal			Nematode		
	ANOSIM R	p	SIMPER Avg. diss. (%)	ANOSIM R	p	SIMPER Avg. diss. (%)
500 m						
Portuguese	0.44	ns	28.72	0.83	***	83.28
Catalan	0.44	ns	28.07	0.83	ns	50.27
South Adriatic	0.44	ns	27.53	0.83	***	56.44
1000 m						
Portuguese	0.35	ns	41.24	0.69	***	84.97
Catalan	0.35	ns	41.02	0.69	ns	48.52
South Adriatic	0.35	ns	44.41	0.69	ns	59.01
2000 m						
Portuguese	0.64	ns	40.94	0.673	***	83.92
Catalan	0.64	ns	37.53	0.673	ns	54.19
South Adriatic	0.64	na	na	0.673	na	na

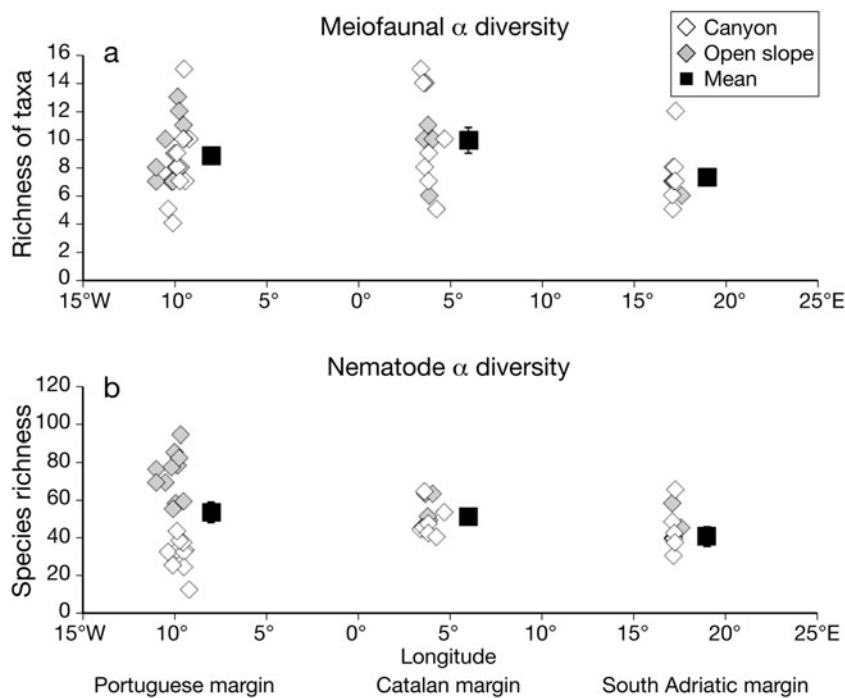

Fig. 2. α -diversity in different deep-sea regions measured as (a) richness of meiofaunal higher taxa and (b) nematode species richness. White diamonds indicate stations within canyons, grey diamonds indicate stations within open slopes and black squares indicate the mean \pm SE

puts can change with increasing water depth, bathymetric gradients could reflect changes in the amount and quality of available food (Danovaro et al. 1999). A recent study reported that nematode biodiversity changed with water depth, and that bathymetric gradients were higher than changes observed at large spatial scales (>2500 km distance) at equal depths (Dano-

varo et al. 2008a). However, investigations conducted in a hadal trench of the South Pacific Ocean revealed that differences in water depth were responsible for significant differences in nematode species richness when food availability was not a limiting factor (Gambi et al. 2003).

Results presented here indicate that meiofaunal higher taxa richness and nematode species richness changed significantly with increasing water depth in about half of the investigated transects, but did not show consistent patterns. In fact, in both open slopes and canyons, increasing and decreasing patterns in species richness were observed (Table 2). These results are in agreement with the lack of consistent patterns in trophic resources (Pusceddu et al. in press), which showed the presence of increasing or decreasing concentrations of sediment organic matter in different transects independently from the regions (northeastern Atlantic, western and central Mediterranean) or habitats (slopes, canyons) investigated. The multivariate, multiple regression analyses indicated that quantity and quality of organic matter explained an important portion of the variances of the diversity indices, but temperature and physicochemical conditions also played an important role in determining the observed patterns. In addition, the analysis of nematode biodiversity revealed the presence of significant differences in species composition at different depths at all of the investigated transects, indicating that, independently from the presence of a significantly different species richness or organic matter content, bathymetric differences were always associated with significant changes in species composition (Table 3).

α , β and γ diversity in deep-sea margins

The comparison of the nematode diversity (as nematode species richness) at equal depths (i.e. separately at 500, 1000 and 2000 m depth, Fig. 2) revealed that the Portuguese margin contained the highest point diversity (number of species in a single sample) and that

Table 5. Meiofaunal higher taxa found in the 3 study regions

Taxon	%
Portuguese margin	
Nematoda	89.414
Copepoda	7.201
Polychaeta	2.124
Kinorhyncha	0.420
Oligochaeta	0.242
Ostracoda	0.186
Tardigrada	0.088
Bivalvia	0.070
Isopoda	0.063
Nemerta	0.058
Cumacea	0.038
Turbellaria	0.028
Amphiopoda	0.015
Tanaidacea	0.010
Acarina	0.008
Echinodermata larvae	0.008
Gastrotricha	0.005
Priapulida	0.005
Priapulida larvae	0.005
Gnatostomulida	0.005
Sipunculida	0.003
Holothurians	0.003
Cnidaria	0.003
Catalan margin	
Nematoda	91.121
Copepoda	4.934
Polychaeta	1.600
Nemerta	1.136
Oligochaeta	0.271
Kinorhyncha	0.211
Ostracoda	0.129
Cumacea	0.120
Isopoda	0.108
Turbellaria	0.077
Bivalvia	0.069
Priapulida	0.056
Tardigrada	0.052
Echinodermata	0.043
Gastrotricha	0.030
Amphiopoda	0.026
Tanaidacea	0.013
Sipunculida	0.004
South Adriatic margin	
Nematoda	93.751
Copepoda	3.066
Polychaeta	1.029
Priapulida larvae	0.847
Tardigrada	0.504
Kinorhyncha	0.407
Decapoda larvae	0.150
Isopoda	0.086
Bivalvia	0.043
Ostracoda	0.032
Cnidaria	0.032
Oligochaeta	0.021
Cumacea	0.021
Acarina	0.011

such biodiversity showed a tendency to decrease moving eastward. However, despite such differences, the values of α diversity (richness of meiofaunal higher taxa or nematode species in 3 replicates from 1 site) were, on average, similar in all of the study regions.

The values of α diversity (nematode Shannon diversity) reported in the present study are higher than those reported by Garcia et al. (2007) for the Portuguese margin. Such a discrepancy could be due to different environmental factors, sampling seasons or sampling mesh sizes (20 versus 48 μm , respectively, which could have led to retain also the smallest organisms).

Overall, the richness of meiofaunal higher taxa and the biodiversity of nematodes did not show significant differences when canyons and adjacent open slopes were compared. Only along the Portuguese margin and at 500 m depth in the South Adriatic margin was nematode diversity significantly lower in canyons than in slopes (in agreement with Garcia et al. 2007, Ingels et al. 2009 who found lower diversity in the Nazaré canyon than in the adjacent open slope). Since higher concentrations of potential food resources were found in the Portuguese canyons than in the adjacent open slopes (for more details see Pusceddu et al. in press), the results of the present study provide further evidence that the amount of sediment organic matter is not sufficient to explain the observed changes in benthic biodiversity. The lower nematode biodiversity observed in canyons could be due to the presence of peculiar hydrodynamic conditions (Garcia et al. 2007), which could allow the colonization of a lower number of species. However, topographic features could also contribute to the differences as observed in the South Adriatic margin at 500 m depth; for instance, the lower nematode species richness in canyon C could be related to the presence of hard substrates (Trincardi et al. 2007). Overall, results presented here are in good agreement with previous studies, which reported that canyons were characterized by higher faunal abundance and biomass but lower diversity (Gage et al. 1995, Vetter & Dayton 1998, Curdia et al. 2004).

The analysis of functional (trophic) diversity and life strategies (1 – ITD and MI) did not display clear differences between canyons and slopes in any of the study regions. The maturity index always displayed intermediate values of 2.5 to 3.0, indicating that the nematode assemblages were characterized by a mixture of colonisers and persisters, both in canyons and open slopes of all regions (Gambi et al. 2003, Danovaro et al. 2008a).

Values of β diversity were always very high, but the dissimilarity in nematode species composition between canyons and open slopes of the Portuguese margin (~87%) was much higher than the dissimilarity measured in the margins of the Mediterranean Sea (range

Table 6. SIMPER and ANOSIM of the dissimilarity in meiofaunal higher taxonomic and nematode species composition between the study regions at equal sampling depths. Avg. diss.: average dissimilarity; ***p < 0.001; **p < 0.01; ns: not significant; na: not available

Depth	Region	Meiofauna			Nematode		
		ANOSIM R	p	SIMPER Avg. diss. (%)	ANOSIM R	p	SIMPER Avg. diss. (%)
500 m	Portuguese vs Catalan	0.1	ns	37.8	0.7	***	93.0
	Portuguese vs S Adriatic	0.3	**	38.0	0.6	***	91.0
	Catalan vs S Adriatic	0.7	**	50.0	0.9	***	83.0
1000 m	Portuguese vs Catalan	0.0	ns	24.5	0.6	***	91.0
	Portuguese vs S Adriatic	0.5	***	50.1	0.4	***	89.0
	Catalan vs S Adriatic	0.5	***	42.0	0.9	***	82.0
2000 m	Portuguese vs Catalan	0.7	**	50.4	0.8	***	89.0
	Portuguese vs S Adriatic	na	na	na	na	na	na
	Catalan vs S Adriatic	na	na	na	na	na	na

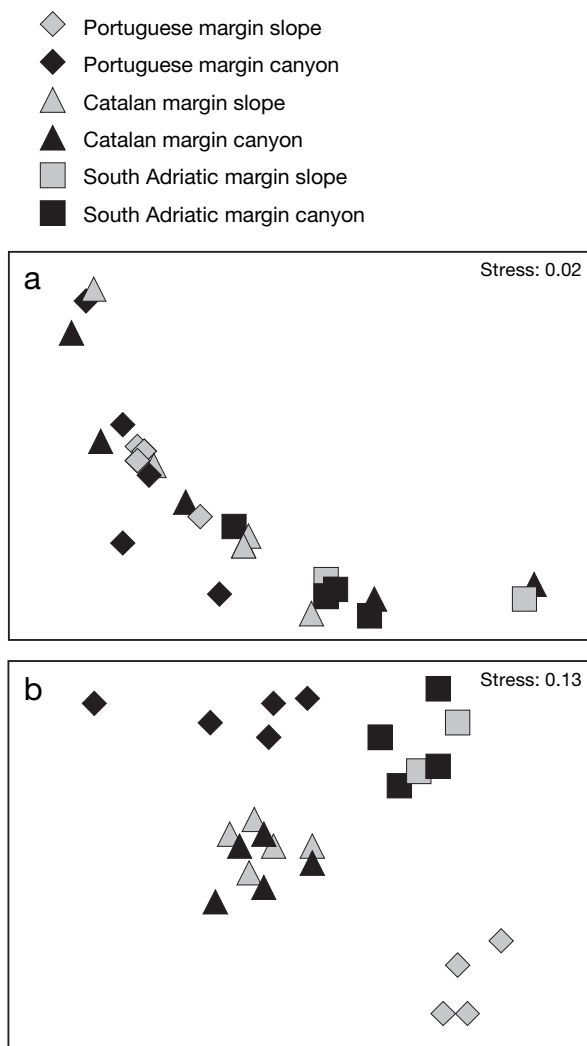

Fig. 3. Non-metric multidimensional scaling plot showing the similarity in (a) meiofaunal taxonomic composition and (b) nematode species composition between canyons and open slopes considering equal water column depths (i.e. 500, 1000 and 2000 m)

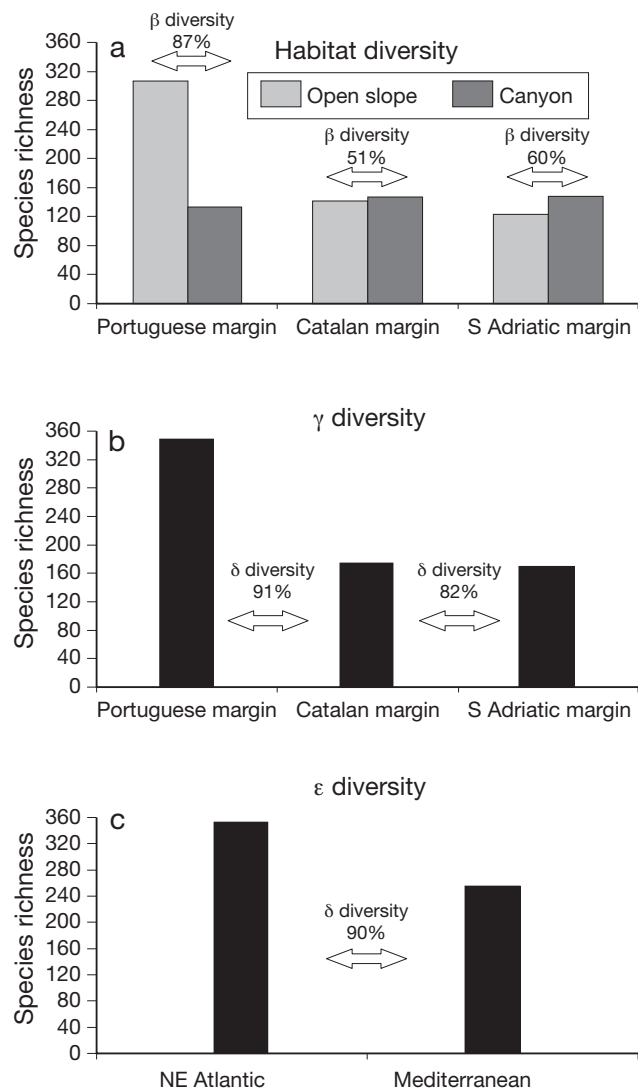

Fig. 4. Species richness of nematodes at different spatial scales: (a) habitat diversity; (b) γ diversity (regional) and (c) ϵ diversity (biogeographical). In (c), 'NE Atlantic' corresponds to the Portuguese margin and 'Mediterranean' includes the Catalan and South Adriatic margins

Table 7. Multivariate multiple regression analysis carried out on the values of the biodiversity indices at all sites, canyons and open slopes. % Var: percentage of explained variance. ***p < 0.001; **p < 0.01; *p < 0.05

Variable	SS	F	p	% Var	Cumulative %
All sites					
Pigment	4960.7	21.4	***	14.1	14.1
Silt %	3058.1	14.6	***	8.7	22.8
Bottom salinity	803.2	3.9	***	2.3	25.1
Bottom temperature	874.0	4.4	**	2.5	27.6
Biopolymeric C	1045.2	5.4	**	3.0	30.6
Protein to biopolymeric C ratio	243.4	1.3	**	0.7	31.3
Pigment to biopolymeric C ratio	123.8	0.6	ns	0.4	31.6
Water depth	71.3	0.4	ns	0.2	31.9
Protein to carbohydrate ratio	23.5	0.1	ns	0.1	31.9
Sand %	0.0	0.0	ns	0.0	31.9
Canyons					
Sand %	4308.9	16.7	***	18.6	18.6
Pigment	2626.7	11.6	***	11.3	29.9
Bottom salinity	567.8	2.6	ns	2.5	32.4
Protein to biopolymeric C ratio	392.0	1.8	ns	1.7	34.1
Biopolymeric C	299.7	1.4	ns	1.3	35.4
Pigment to biopolymeric C ratio	304.4	1.4	ns	1.3	36.7
Bottom temperature	95.5	0.4	ns	0.4	37.1
Water depth	22.8	0.1	ns	0.1	37.2
Silt %	0.0	0.0	ns	0.0	37.2
Protein to carbohydrate ratio	2.4	0.0	ns	0.0	37.2
Slopes					
Protein to carbohydrate ratio	695.2	7.3	**	11.7	11.7
Bottom salinity	158.5	1.7	ns	2.7	14.3
Pigment to biopolymeric C ratio	76.6	0.8	ns	1.3	15.6
Bottom temperature	283.1	3.1	ns	4.7	20.3
Pigment	64.2	0.7	ns	1.1	21.4
Protein to biopolymeric C ratio	55.8	0.6	ns	0.9	22.4
Silt %	46.5	0.5	ns	0.8	23.1
Biopolymeric C	10.3	0.1	ns	0.2	23.3
Water depth	7.7	0.1	ns	0.1	23.4
Sand %	0.0	0.0	ns	0.0	23.4

51 to 60%). Such differences in turnover diversity were responsible for the higher values of γ diversity (i.e. the regional diversity; Fig. 4b) of the Atlantic margin (349 species, ca. double that in the Catalan or the S Adriatic margins — 174 and 170 species, respectively).

δ and ϵ diversity in deep-sea margins

The δ -diversity, measured as turnover of nematode species among different regions (Portuguese versus Catalan versus S Adriatic) was always >80%, with highest differences between the 'cold' deep Atlantic and the

'warm' deep Mediterranean (>91%). Since the deep Atlantic and deep Mediterranean basins are physically separated by the Strait of Gibraltar and display enormous differences in terms of deep-water temperatures (~10°C), the differences in species composition between the 2 regions (δ diversity) are not surprising. But the high δ diversity between western and central Mediterranean systems (~82%) suggests that the difference in temperature is not the only driver of turnover diversity among regions. Rather, these results suggest that each deep-sea region is characterised by the presence of a specific assemblage and species composition. These results are confirmed by the NMDS analysis, which showed the presence of strong differences among the investigated regions in terms of richness of meiofaunal higher taxa and nematode species composition (Fig. 3), even when the analysis was performed at equal depths (i.e. 500, 1000 and 2000 m).

As a result of the important differences observed among the western and central Mediterranean regions, the overall differences in species richness (ϵ diversity) of the deep northeastern Atlantic and Mediterranean basins were less pronounced than those observed in terms of γ diversity. Overall, on the basis of the station samples (23 stations in the deep Mediterranean versus 21 in the deep Atlantic) the ϵ diversity of the deep Mediterranean basin was only 27% lower than that of the deep Atlantic. At the same time, it should be taken into account that the depth ranges of the 2 systems were different: 200 to 2000 m depth for the

Mediterranean stations and 500 to 5000 m depth for the Atlantic. Since we demonstrated here that bathymetric differences are a key source of turnover diversity, it is possible that the quantitative differences reported are also influenced by the differences in extensions and depth ranges between the Atlantic and the Mediterranean margins. Overall, the data on nematode ϵ diversity in the deep sea suggest that, conversely to what was expected, the meiofauna and, particularly, nematode diversity of the deep Mediterranean basin is highly diversified and, thus, the deep Mediterranean is not biodiversity-depleted, but rather a diversity-rich biogeographical province.

The results of the present study indicate that differences in β and δ diversity and not α diversity are crucial to set-up or describe the deep-sea biodiversity at a regional scale, and that the analysis of the factors driving turnover diversity are crucial for a predictive understanding of the spatial patterns and species composition of deep-sea assemblages in different biogeographic regions.

Acknowledgements. This study has been conducted in the framework of the EU Integrated Project HERMES (Hotspot Ecosystem Research on the Margins of European Seas, contract N. GOCE-CT-2005-511234-1). The authors are indebted to M. Canals, X. Durrieu De Madron, S. Heussner, H. de Stigter and F. Trincardi for support and useful discussion, and to the crews of the RVs 'Pelagia' (The Netherlands), 'Universitatis' and 'Urania' (Italy) for their help during sea-going activities.

LITERATURE CITED

- Accornero A, Picon P, de Bovée F, Charrière B, Buscail R (2003) Organic carbon budget at the sediment–water interface on the Gulf of Lions continental margin. *Cont Shelf Res* 23:79–92
- Baguley JG, Montagna PA, Hyde LJ, Kalke RD, Rowe GT (2006) Metazoan meiofauna abundance in relation to environmental variables in the northern Gulf of Mexico deep sea. *Deep-Sea Res I* 53:1344–1362
- Bongers T, Alkemade R, Yeates GW (1991) Interpretation of disturbance-induced maturity decrease in marine nematode assemblages by means of the Maturity Index. *Mar Ecol Prog Ser* 76:135–142
- Canals M, Casamor JL, Lastras G, Monaco A and others (2004) The role of canyons in strata formation. *Oceanography* 17:80–91
- Canals M, Puig P, Durrieu de Madron X, Heussner S, Palanques A, Fabres J (2006) Flushing submarine canyons. *Nature* 444:354–357
- Clarke KR (1993) Non-parametric multivariate analyses of changes in community structure. *Aust J Ecol* 18:117–143
- Cook AA, Lambshead PJD, Hawkins LE, Mitchell N, Levin LA (2000) Nematode abundance at the oxygen minimum zone in the Arabian Sea. *Deep-Sea Res II* 47:75–85
- Curdia J, Carvalho S, Ravara A, Gage JD, Rodrigues AM, Quintino V (2004) Deep macrobenthic communities from Nazaré submarine canyon (NW Portugal). *Sci Mar* 68:171–180
- Danovaro R, Marralle D, Della Croce N, Dell'Anno A, Fabiano M (1998) Heterotrophic nanoflagellates, bacteria and labile organic compounds in continental shelf and deep-sea sediments of the Eastern Mediterranean. *Microb Ecol* 35:244–255
- Danovaro R, Dinét A, Duineveld G, Tselepidis A (1999) Benthic response to particulate fluxes in different trophic environments: a comparison between the Gulf of Lions–Catalan Sea (western-Mediterranean) and the Cretan Sea (eastern-Mediterranean). *Prog Oceanogr* 44:287–312
- Danovaro R, Gambi C, Della Croce N (2002) Meiofauna hotspot in the Atacama Trench (southern Pacific Ocean). *Deep-Sea Res I* 49:843–857
- Danovaro R, Dell'Anno A, Pusceddu A (2004) Biodiversity response to climate change in a warm deep sea. *Ecol Lett* 7:821–828
- Danovaro R, Gambi C, Lampadariou N, Tselepidis A (2008a) Deep-sea biodiversity in the Mediterranean Basin: testing for longitudinal, bathymetric and energetic gradients. *Ecography* 31:231–244
- Danovaro R, Gambi C, Dell'Anno A, Corinaldesi C and others (2008b) Exponential decline of deep-sea ecosystem functioning linked to benthic biodiversity loss. *Curr Biol* 18:1–8
- de Bovée F, Guidi LD, Soyer J (1990) Quantitative distribution of deep-sea meiobenthos in the northwestern Mediterranean (Gulf of Lions). *Cont Shelf Res* 10:1123–1145
- Deprez T, Steyaert M, Vanaverbeke J, Speybroeck J and others (2005) NeMys, World Wide Web electronic publication, www.nemys.ugent.be. Department of Marine Biology, Ghent University
- De Troch M, Van Gansbeke D, Vincx M (2006) Resource availability and meiofauna in sediment of tropical seagrass beds: local versus global trends. *Mar Environ Res* 61:59–73
- Duineveld G, Lavaleye M, Berghuis E, de Wilde P (2001) Activity and composition of the benthic fauna in the Whittard Canyon and the adjacent continental slope (NE Atlantic). *Oceanol Acta* 24:69–83
- Gage JD (2004) Diversity in deep-sea benthic macrofauna: the importance of local ecology, the larger scale, history and the Antarctic. *Deep-Sea Res II* 51:1689–1708
- Gage JD, Tyler PA (1991) Deep-sea biology: a natural history of organisms at the deep-sea floor. Cambridge University Press, Cambridge
- Gage JD, Lamont PA, Tyler PA (1995) Deep-sea macrobenthic communities at contrasting sites off Portugal, preliminary results. 1. Introduction and diversity comparisons. *Int Rev Gesamten Hydrobiol* 80:235–250
- Gambi C, Vanreusel A, Danovaro R (2003) Biodiversity of nematode assemblages from deep-sea sediments of the Atacama Slope and Trench (south Pacific Ocean). *Deep-Sea Res I* 50:103–117
- García R, Koho KA, De Stigter HC, Epping E, Koning E, Thomsen L (2007) Distribution of meiobenthos in the Nazaré canyon and adjacent slope (western Iberian Margin) in relation to sedimentary composition. *Mar Ecol Prog Ser* 340:207–220
- Gaston KJ (2000) Global patterns in biodiversity. *Nature* 405:220–227
- Gili JM, Bouillon J, Pages E, Palanques A, Puig P (1999) Submarine canyons as habitats of prolific plankton populations: three new deep-sea Hydroidomedusae in the western Mediterranean. *Zool J Linn Soc* 125:313–329
- Gray JS (2000) The measurement of marine species diversity, with an application to the benthic fauna of the Norwegian continental shelf. *J Exp Mar Biol Ecol* 250:23–49
- Greene CH, Wiebe PH, Burczynski JE, Youngbluth MJ (1988) Acoustical detection of high-density demersal krill layers in the submarine canyons off Georges Bank. *Science* 241:359–361
- Heip C, Vincx M, Vranken G (1985) The ecology of marine nematodes. *Oceanogr Mar Biol Annu Rev* 23:399–489
- Hurlbert SH (1971) The non-concept of species diversity: a critique and alternative parameters. *Ecology* 52:577–586
- Ingels J, Kiriakoulakis K, Wolff GA, Vanreusel A (2009) Nematode diversity and its relation to the quantity and quality of sedimentary organic matter in the deep Nazaré Canyon, Western Iberian Margin. *Deep-Sea Res I* 56:1521–1539
- Jablonski D, Bottjer DJ (1990) The origin and diversification of major groups, environmental patterns and macroevolutionary lags. In: Taylor PD, Larwood GP (eds) Major evolutionary radiations. Clarendon Press, Oxford, p 17–57

- Jensen P (1987) Feeding ecology of free-living aquatic nematodes. *Mar Ecol Prog Ser* 35:187–196
- Jensen P (1988) Nematode assemblages in the deep-sea benthos of Norwegian Sea. *Deep-Sea Res I* 35:1173–1184
- Lambshhead PJD, Schalk P (2001) Overview of marine invertebrate biodiversity. In: Levin S (ed) *Encyclopaedia of biodiversity*, Vol 1. Academic Press, San Diego, CA, p 543–559
- Lambshhead PJD, Tietjen J, Ferrero T, Jensen P (2000) Latitudinal diversity gradients in the deep sea with special reference to North Atlantic nematodes. *Mar Ecol Prog Ser* 194:159–167
- Lambshhead PJD, Brown CJ, Ferrero TJ, Mitchell NJ, Smith CR, Hawkins LE, Tietjen J (2002) Latitudinal diversity patterns of deep-sea marine nematodes and organic fluxes: a test from the central equatorial Pacific. *Mar Ecol Prog Ser* 236:129–135
- Levin LA, Etter RJ, Rex MA, Gooday AJ and others (2001) Environmental influences on regional deep-sea species diversity. *Annu Rev Ecol Syst* 32:51–93
- McArdle BH, Anderson MJ (2001) Fitting multivariate models to community data: a comment on distance-based redundancy analysis. *Ecology* 82:290–297
- Moens T, Vincx M (1997) Observations on the feeding ecology of estuarine nematodes. *J Mar Biol Assoc UK* 77:211–227
- Moens T, Verbeec LK, Vincx M (1999) Feeding biology of a predatory and a facultative predatory nematode (*Enoploides longispiculosus* and *Adoncholaimus fucus*). *Mar Biol* 134:585–593
- Pielou EC (1975) *Ecological diversity*. John Wiley, New York
- Platt HM, Warwick RM (1983) A synopsis of the free-living marine nematodes. Part I: British enoplids. Cambridge University Press, Cambridge
- Platt HM, Warwick RM (1988) A synopsis of the free-living marine nematodes. Part II: British chromadorids. Cambridge University Press, Cambridge
- Pusceddu A, Gambi C, Zeppilli D, Bianchelli S, Danovaro R (2009) Organic matter composition, metazoan meiofauna and nematode biodiversity in Mediterranean deep-sea sediments. *Deep-Sea Res II* 56:755–762
- Pusceddu A, Bianchelli S, Canals M, Durrieu De Madron X and others (in press) Organic matter in sediments of canyons and open slopes along European continental margins. *Deep-Sea Res I*
- Rex MA, Stuart CT, Etter RJ (2001) Do deep-sea nematodes show a positive latitudinal gradient of species diversity? The potential role of depth. *Mar Ecol Prog Ser* 210:297–298
- Rex MA, Crame JA, Stuart CT, Clarke A (2005) Large-scale biogeographic patterns in marine mollusks: a confluence of history and productivity? *Ecology* 86:2288–2297
- Sanders HL (1968) Marine benthic diversity: a comparative study. *Am Nat* 102:243–282
- Seinhorst JW (1959) A rapid method for the transfer of nematodes from fixative to anhydrous glycerine. *Nematologica* 4:67–69
- Snelgrove PVR, Smith CR (2002) A riot of species in an environmental calm: the paradox of the species-rich deep-sea floor. *Oceanogr Mar Biol Annu Rev* 40:311–342
- Soetaert K, Heip C (1995) Nematode assemblages of deep-sea and shelf break sites in the North Atlantic and Mediterranean Sea. *Mar Ecol Prog Ser* 125:171–183
- Thiel H (1975) The size structure of the deep-sea benthos. *Int Rev Gesamten Hydrobiol* 60:575–606
- Tietjen JH (1992) Abundance and biomass of metazoan meiobenthos in the deep-sea. In: Rowe G, Pariente V (eds) *Deep-sea food chain and the global carbon cycle*, Vol 60. Kluwer Academic Publishers, Dordrecht, p 45–62
- Trincardi F, Fogliani F, Verdicchio G, Asioli A and others (2007) The impact of cascading currents on the Bari Canyon System, SW-Adriatic Margin (Central Mediterranean). *Mar Geol* 246:208–230
- Van Gaeveer S, Galéron J, Sibuet M, Vanreusel A (2009) Deep-sea habitat heterogeneity influences on meiofaunal communities in the Gulf of Guinea. *Deep-Sea Res II* (in press) doi:10.1016/j.dsr2.2009.04.008
- Vanhove S, Vermeeren H, Vanreusel A (2004) Meiofauna towards the south Sandwich Trench (750–6300 m), focus on nematodes. *Deep-Sea Res II* 51:1665–1687
- Vetter EW (1995) Detritus-based patches of high secondary production in the nearshore benthos. *Mar Ecol Prog Ser* 120:251–262
- Vetter EW, Dayton PK (1998) Macrofaunal communities within and adjacent to a detritus-rich submarine canyon system. *Deep-Sea Res II* 45:25–54
- Vincx M, Bett BJ, Dinert A, Ferrero T and others (1994) Meiobenthos of the deep Northeast Atlantic. In: Blaxter JHS, Southward AJ (eds) *Advances in marine biology*, Vol 30. Academic Press, London, p 2–88
- Warwick RM, Howard HM, Somerfield PJ (1998) A synopsis of the free-living marine nematodes. Part III: monhysterids. Field Studies Council, Shrewsbury
- Weaver PE, Billett DM, Boetius A, Danovaro R, Freiwald A, Sibuet M (2004) Hotspot ecosystem research on Europe's deep-ocean margins. *Oceanography* 17:132–143
- Wieser W (1953) Die Beziehung zwischen Mundhöhlen-gestalt, Ernährungsweise und Vorkommen bei freilebenden marinen Nematoden. *Arkiv Zool* 2-4:439–484
- Wilson GD, Hessler RR (1987) Speciation in the deep-sea. *Annu Rev Ecol Syst* 18:185–207
- Yoklavich M, Greene G, Calliet GM, Sullivan DE, Lea RN, Love MS (1999) Habitat associations of deep-water rockfishes in a submarine canyon: an example of a natural refuge. *Fish Bull* 98:625–641

Appendix 1. Nematode species found in the 3 study regions. Only those species comprising >0.5% of the total are reported

Species	%	Species	%	Species	%
Portuguese margin		Catalan margin		South Adriatic margin	
<i>Sabatieria</i> sp1	4.76	<i>Sabatieria</i> sp1	6.88	<i>Pierrickia</i> sp3	10.87
<i>Halalaimus</i> sp4	4.00	<i>Theristus</i> sp1	4.95	<i>Aegialoalaimus</i> sp4	5.56
<i>Halalaimus</i> sp1	3.46	<i>Sabatieria</i> sp2	4.25	<i>Halalaimus</i> sp4	5.05
<i>Acantholaimus</i> sp4	3.03	<i>Halalaimus</i> sp7	3.75	<i>Sphaerolaimus</i> sp2	4.45
<i>Acantholaimus</i> sp1	2.94	<i>Prochromadorella</i> sp1	3.63	<i>Pierrickia</i> sp4	4.36
<i>Actinonema</i> sp1	2.83	<i>Halalaimus</i> sp4	3.54	<i>Pierrickia</i> sp2	3.59
<i>Daptonema</i> sp1	2.34	<i>Sabatieria</i> sp3	3.49	<i>Halalaimus</i> sp1	2.95
<i>Metadesmolaimus</i> sp2	2.29	<i>Pierrickia</i> sp1	3.34	<i>Sabatieria</i> sp1	2.95
<i>Metalinhomoeus</i> sp1	2.29	<i>Sphaerolaimus</i> sp1	3.28	<i>Desmoscolex</i> sp2	2.87
<i>Pierrickia</i> sp1	2.14	<i>Aegialoalaimus</i> sp1	2.84	<i>Amphimonhystrella</i> sp1	2.57
<i>Linhystera</i> sp1	2.10	<i>Daptonema</i> sp1	2.64	<i>Spilophorella</i> sp1	2.52
<i>Pierrickia</i> sp3	2.06	<i>Desmoscolex</i> sp1	2.52	<i>Syringolaimus</i> sp4	2.48
<i>Aegialoalaimus</i> sp1	1.92	<i>Aponema</i> sp1	2.11	<i>Desmoscolex</i> sp1	2.23
<i>Amphimonhystrella</i> sp1	1.86	<i>Actinonema</i> sp1	1.93	<i>Pierrickia</i> sp1	1.97
<i>Pierrickia</i> sp2	1.73	<i>Acantholaimus</i> sp1	1.87	<i>Actinonema</i> sp1	1.88
<i>Sphaerolaimus</i> sp3	1.62	<i>Amphimonhystrella</i> sp1	1.76	<i>Sabatieria</i> sp3	1.88
<i>Longicyatholaimus</i> sp1	1.52	<i>Sphaerolaimus</i> sp3	1.76	<i>Innocuonema</i> sp1	1.63
<i>Theristus</i> sp3	1.49	<i>Cyartonema</i> sp3	1.70	<i>Sphaerolaimus</i> sp1	1.63
<i>Sphaerolaimus</i> sp4	1.26	<i>Theristus</i> sp3	1.58	<i>Sabatieria</i> sp4	1.37
<i>Praecanthonchus</i> sp1	1.19	<i>Elzalia</i> sp1	1.55	<i>Adoncholaimus</i> sp2	1.24
<i>Sphaerolaimus</i> sp1	1.19	<i>Acantholaimus</i> sp2	1.52	<i>Setosabatieria</i> sp1	1.16
<i>Theristus</i> sp5	1.15	<i>Pselionema</i> sp1	1.32	<i>Anoplostoma</i> sp1	1.03
<i>Syringolaimus</i> sp4	1.15	<i>Chromadora</i> sp1	1.26	<i>Acantholaimus</i> sp6	0.94
<i>Microlaimus</i> sp1	1.08	<i>Diplopetoides</i> sp1	1.26	<i>Hopperia</i> sp1	0.90
<i>Minolaimus</i> sp1	1.08	<i>Paracanthonchus</i> sp3	1.26	<i>Microlaimus</i> sp1	0.81
<i>Theristus</i> sp2	1.04	<i>Hopperia</i> sp1	1.23	<i>Linhystera</i> sp2	0.77
<i>Acantholaimus</i> sp12	1.00	<i>Syringolaimus</i> sp1	1.23	<i>Oxystomina</i> sp1	0.77
<i>Daptonema</i> sp2	1.00	<i>Longicyatholaimus</i> sp1	1.20	<i>Richtersia</i> sp1	0.77
<i>Theristus</i> sp1	1.00	<i>Tricoma</i> sp1	1.11	<i>Sphaerolaimus</i> sp3	0.77
<i>Microlaimus</i> sp2	0.95	<i>Halalaimus</i> sp1	1.08	<i>Halichoanolaimus</i> sp4	0.73
<i>Daptonema</i> sp3	0.89	<i>Paracanthonchus</i> sp2	0.88	<i>Acantholaimus</i> sp5	0.68
<i>Desmoscolex</i> sp5	0.86	<i>Dichromadora</i> sp1	0.76	<i>Desmoscolex</i> sp3	0.64
<i>Microlaimus</i> sp5	0.86	<i>Amphimonhystrella</i> sp3	0.73	<i>Desmodora</i> sp3	0.60
<i>Amphimonhystrella</i> sp2	0.76	<i>Elzalia</i> sp2	0.73	<i>Elzalia</i> sp2	0.60
<i>Linhystera</i> sp2	0.76	<i>Terschellingia</i> sp1	0.73	<i>Acantholaimus</i> sp4	0.56
<i>Marylynnia</i> sp1	0.76	<i>Metadesmolaimus</i> sp1	0.70	<i>Chromadorella</i> sp1	0.56
<i>Paralongicyatholaimus</i> sp1	0.74	<i>Leptolaimus</i> sp1	0.67	<i>Latronema</i> sp3	0.56
<i>Setosabatieria</i> sp1	0.74	<i>Setosabatieria</i> sp1	0.67	<i>Linhystera</i> sp1	0.56
<i>Spilophorella</i> sp1	0.73	<i>Oxystomina</i> sp1	0.64	<i>Diplopetoides</i> sp3	0.51
<i>Acantholaimus</i> sp3	0.67	<i>Sphaerolaimus</i> sp2	0.64	<i>Metacyatholaimus</i> sp1	0.51
<i>Diplopetoides</i> sp1	0.65	<i>Adoncholaimus</i> sp2	0.62	<i>Southerniella</i> sp1	0.51
<i>Halalaimus</i> sp5	0.65	<i>Innocuonema</i> sp1	0.62		
<i>Bathyeurystomina</i> sp1	0.61	<i>Platycoma</i> sp1	0.62		
<i>Oxystomina</i> sp1	0.61	<i>Sabatieria</i> sp5	0.62		
<i>Campylaimus</i> sp1	0.60	<i>Pierrickia</i> sp2	0.56		
<i>Halalaimus</i> sp6	0.58	<i>Acantholaimus</i> sp3	0.53		
<i>Monhystera</i> sp1	0.56	<i>Acantholaimus</i> sp6	0.50		
<i>Comesoma</i> sp1	0.54	<i>Aegialoalaimus</i> sp2	0.50		
<i>Desmoscolex</i> sp3	0.54	<i>Daptonema</i> sp2	0.50		
<i>Pomponema</i> sp1	0.54	<i>Theristus</i> sp4	0.50		



Genetic population structures of the blue starfish *Linckia laevigata* and its gastropod ectoparasite *Thyca crystallina*

M. Kochzius^{1,*,**}, C. Seidel^{1,2}, J. Hauschild^{1,3}, S. Kirchhoff¹, P. Mester¹,
I. Meyer-Wachsmuth¹, A. Nuryanto^{1,4}, J. Timm¹

¹Biotechnology and Molecular Genetics, FB2-UFT, University of Bremen, Leobenerstrasse UFT, 28359 Bremen, Germany

²Present address: Institute of Biochemistry, University of Leipzig, Brüderstrasse 34, 04103 Leipzig, Germany

³Present address: Friedrich-Loeffler-Institut, Bundesforschungsinstitut für Tiergesundheit, Institut für Nutztiergenetik, Höltystrasse 10, 31535 Neustadt, Germany

⁴Present address: Faculty of Biology, Jenderal Soedirman University, Dr. Suparno Street, Purwokerto 53122, Indonesia

ABSTRACT: Comparative analyses of the genetic population structure of hosts and parasites can be useful to elucidate factors that influence dispersal, because common ecological and evolutionary processes can lead to congruent patterns. We studied the comparative genetic population structure based on partial sequences of the mitochondrial cytochrome oxidase I gene of the blue starfish *Linckia laevigata* and its gastropod ectoparasite *Thyca crystallina* in order to elucidate evolutionary processes in the Indo-Malay Archipelago. AMOVA revealed a low fixation index but significant genetic population structure ($\phi_{ST} = 0.03$) in *L. laevigata*, whereas *T. crystallina* showed panmixing ($\phi_{ST} = 0.005$). According to a hierarchical AMOVA, the populations of *L. laevigata* could be assigned to the following groups: (1) Eastern Indian Ocean, (2) central Indo-Malay Archipelago and (3) Western Pacific. This pattern of a genetic break in *L. laevigata* between the Indian and Pacific Ocean, congruent to studies on other marine species in the Indo-Malay Archipelago, is likely due to allopatry caused by Pliocene and Pleistocene glacial sea level low stands.

KEY WORDS: COI · Coral Triangle · Coral reef · Phylogeography · Population expansion · Southeast Asia

Resale or republication not permitted without written consent of the publisher

INTRODUCTION

Comparative analyses of the genetic population structure of a host and its parasite can be used to elucidate factors that influence dispersal (Criscione 2008), because common ecological and evolutionary processes can lead to congruent patterns (Bermingham & Moritz 1998, Avise 2000). The blue starfish *Linckia laevigata* (Ophidiasteridea; Chao 1999) is widely distributed on Indo-Pacific coral reefs, from the Western Indian Ocean across the Indo-Malay Archipelago to southeastern Polynesia (Yamaguchi 1977). It is frequently parasitised by the obligate and strictly specific ectoparasitic gastropod *Thyca crystallina* (Eulimidae;

Warén 1980, Janssen 1985), which penetrates the radial hemal and perihemal system of *L. laevigata* with its proboscis to obtain nutrients (Egloff et al. 1988). *T. crystallina* seems to be co-distributed with its host, ranging from the Western Indian Ocean across the Indo-Malay Archipelago and northeastern Australia to Samoa and Fiji (Sloan et al. 1979, Warén 1980). Infection rates of *L. laevigata* with *T. crystallina* vary among populations, ranging from 14.3% in Fiji (Egloff et al. 1988), 15.7% (Troncoso & Van Goethem 1998) and 22.3% (Bouillon & Jangoux 1984) in eastern New Guinea to 62.0% in the Moluccas (Elder 1979).

Here we compare the genetic population structure of the host *Linckia laevigata* and its parasite *Thyca*

*Email: kochzius@uni-bremen.de

**All authors except M.K. and C.S. are in alphabetical order

crystallina in the Indo-Malay Archipelago. This highly dynamic region in terms of biodiversity, ecology, geology and oceanography is the centre of marine shallow water biodiversity (Briggs 1999, Hoeksema 2007). Molecular phylogenetic studies have shown a break between the Indian and Pacific Oceans, e.g. in lionfishes (Kochzius et al. 2003), clownfishes (Timm et al. 2008), and damselfishes (Froukh & Kochzius 2008). Additionally, a growing number of population genetic studies in the Indo-Malay Archipelago show a complex pattern of divergent lineages and restricted gene flow, e.g. in a clownfish (Timm & Kochzius 2008), giant clams (Kochzius & Nuryanto 2008, Nuryanto & Kochzius 2009), and a mushroom coral (Knittweis et al. 2009).

Plate tectonic movements in the Indo-Malay Archipelago and global fluctuation of sea level during multiple Pliocene and Pleistocene glaciations are the primary hypothesised triggers for this genetic separation of the 2 ocean basins. Most of the islands in the Indo-Malay Archipelago did not exist or were not at their current position about 30 million years ago. During that time, water masses of the Pacific South Equatorial Current (SEC) entered the Indian Ocean via the so-called Indonesian seaway. This current pattern started to change about 25 million years ago, due to the development of Sulawesi by the amalgamation of several fragments and the northward movement of New Guinea, the Bird's Head Peninsula, and Australia (Hall 1998). The Indonesian seaway was finally closed about 5 million years ago by the northward displacement of New Guinea (Cane & Molnar 2001). Since then, the major exchange of water masses between the 2 oceans has been facilitated by the Indonesian throughflow (ITF), which originates from the northern Pacific (Gordon & Fine 1996, Gordon 2005).

Additionally, multiple glaciations in the Pliocene and Pleistocene caused global fluctuations in sea level with low stands of up to 120 m below present sea level (Krantz 1991, Rohling et al. 1998, Siddall et al. 2003). Shallow shelf areas such as the Sunda shelf were exposed, and ocean basins were separated (Voris 2000; Fig. 1). Molecular clock estimates support the view of allopatric speciation in separate ocean basins during the Pliocene and Pleistocene in some species (Kochzius et al. 2003, Timm et al. 2008).

The present study aims to elucidate if common ecological and evolutionary processes lead to congruence in the genetic structure of *Linckia laevigata* and *Thyca crystallina* populations from the Indo-Malay Archipelago. The genetic marker used for both species in the present study is the cytochrome c oxidase I gene (COI), which is suitable to investigate the genetic population structure of starfishes (e.g. Harley et al. 2006) and snails (e.g. Reid et al. 2006).

MATERIALS AND METHODS

Sampling. Tissue samples from 270 specimens of the blue starfish *Linckia laevigata* and 324 specimens of its ectoparasite, the snail *Thyca crystallina*, were collected during several field trips from 2004 to 2007 at 24 sample sites across the Indo-Malay Archipelago (Fig. 1A,C, Table 1). Several colour morphs of *L. laevigata* are known, such as blue, orange, green, and violet. Since genetic studies indicated that colour variation is congruent to genetic variation (Williams & Benzie 1998) and that species boundaries in *Linckia* are difficult to define (Williams 2000), only blue colour morphs were analysed. Tissue samples were preserved in >96% ethanol and later stored at 4°C.

DNA extraction, amplification and sequencing. Extraction of genomic DNA from both species was done with the Chelex method, following the protocol of Walsh et al. (1991). A fragment of the mitochondrial COI gene was used for both species as molecular marker and amplified with the primers from Folmer et al. (1994). PCR was conducted in a volume of 50 µl and contained 2 µl DNA template, 10 mM Tris-HCl (pH 9), 50 mM KCl, 4 mM MgCl₂, 0.4 µM of each primer, 0.2 mM dNTPs, 2 µl BSA (2 mg/ml) and 1 U *Taq* polymerase. The following temperature profile was used for the PCR: 94°C for 5 min, followed by 35 cycles of 1 min at 94°C, 1.5 min at 45°C and 1 min at 72°C. Final extension was conducted at 72°C for 5 min. The PCR products were purified using the QIAquick spin column PCR purification kit (Qiagen), following the manufacturer's protocol. Sequencing was done using the DyeDeoxy terminator chemistry (PE Biosystem) and an automated sequencer (ABI PRISM 310 and 3100, Applied Biosystems). New primers were designed for cycle sequencing in *Linckia laevigata* (*Linckia* Seq Frw [forward]: 5'-AAA ATC AGA ATA AGT GCT GGA-3'; *Linckia* Seq Rev [reverse]: 5'-TTT GGA GCT TGA GCT GGA ATG-3') and *Thyca crystallina* (*Thyca* Seq Frw [forward]: 5'-TAT TGT AAC TGC TCA TGC TTT TG-3').

Genetic diversity. Sequences were edited with the programmes Sequence Navigator (version 1.0.1, Applied Biosystems) or Seqman (version 4.05, DNASTar). They were translated to amino acids with the program Bioedit (version 7.0.9.0, Hall 1999) in order to exclude mistakes in sequencing and to verify if a functional mitochondrial DNA sequence was obtained and not a nuclear pseudogene. Multiple alignment was done using Clustal W (Thompson et al. 1994) as implemented in the software Bioedit. Haplotype diversity *h* (Nei 1987) and nucleotide diversity (Nei & Jin 1989) were calculated with the programme Arlequin (<http://cmpg.unibe.ch/software/arlequin3>, version 3.11; Excoffier et al. 2005).

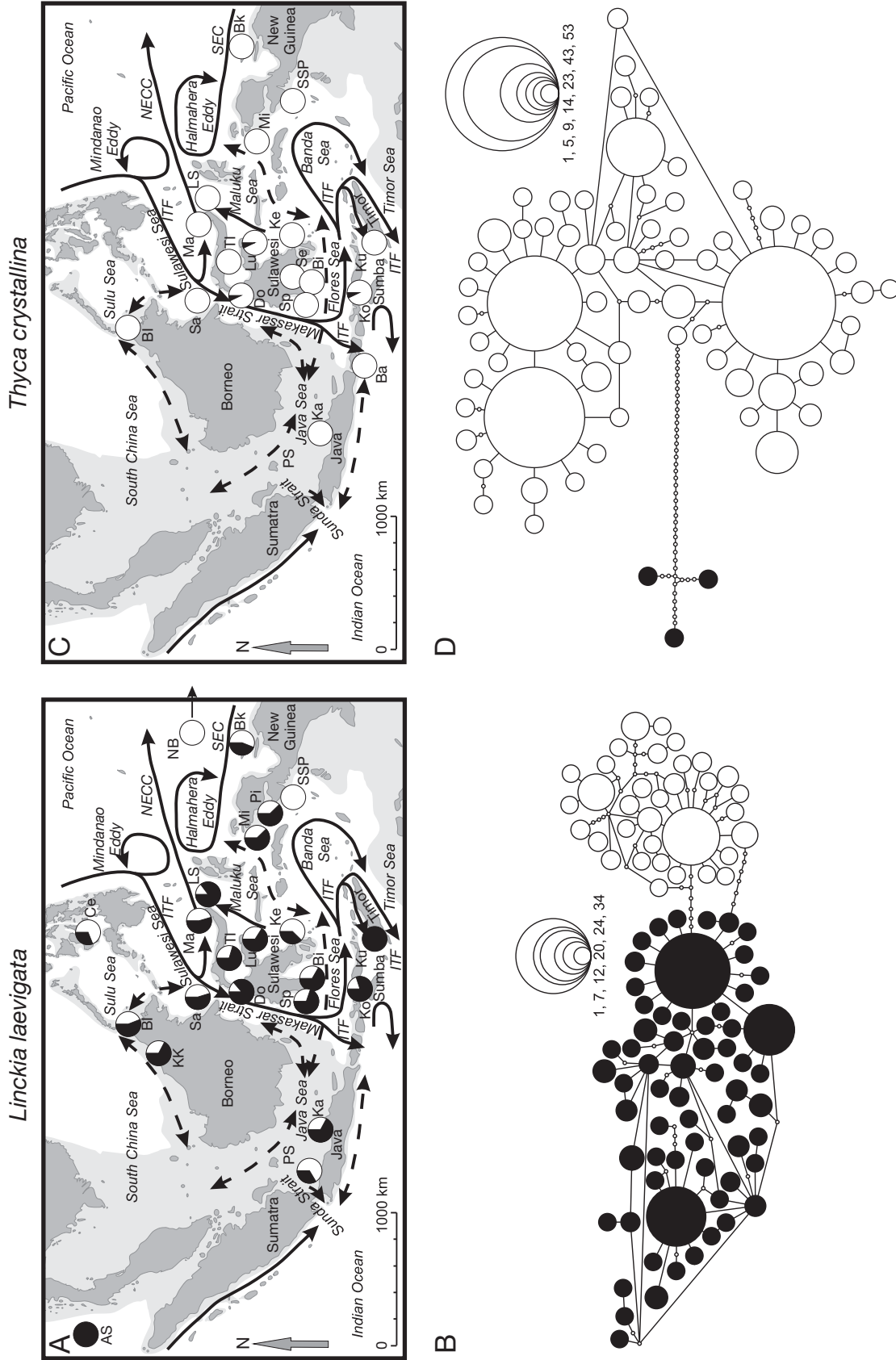

Fig. 1. *Linckia laevigata* (A, B) and *Thyca crystallina* (C, D). (A, C) Indo-Malay Archipelago with sample sites (for abbreviations see Table 1) as well as oceanographic patterns with dominant (solid lines) and seasonally changing (dashed lines) currents (Wyrki 1961, Gordon & Fine 1996, Gordon 2005). ITF: Indonesian throughflow; SEC: Southern Equatorial Current; NECC: Northern Equatorial Counter Current. Pleistocene maximum sea level low stand of 120 m is indicated by the light grey area (Voris 2000). Pie charts represent the proportion of clades defined in the network at the different sample sites. (B, D) Networks of mitochondrial cytochrome c oxidase I haplotypes. Large circles represent haplotypes and connecting lines between them one mutational step. The size of the circles is proportional to haplotype frequency. Small circles indicate missing intermediate haplotypes

Table 1. *Linckia laevigata* and *Thyca crystallina*. Sample sites in the Indo-Malay Archipelago, number of sequences (n), number of haplotypes (N_{hp}), number of haplotype diversity (h), nucleotide diversity (π), Tajima's D, Fu's Fs, sum of square deviation (SSD) and Harpending's raggedness index (HRI). *: 0.05 ≥ p ≥ 0.01; **: 0.01 > p ≥ 0.001; ***: p < 0.001; ns: not significant, -: not determined

Sample site	Code	n	N _{hp}	<i>Linckia laevigata</i>				<i>Thyca crystallina</i>							
				Genetic diversity	Neutrality tests	Mismatch distribution	HRI	Genetic diversity	Neutrality tests	Mismatch distribution	HRI				
		h	π (%)	Tajima's D	Fu's Fs	SSD	HRI	n	N _{hp}	h	π (%)	Tajima's D	Fu's Fs	SSD	HRI
Andaman Sea	AS	3	3	1.00	1.4	0.00 ^{ns}	0.59 ^{ns}	0.37 ^{ns}	1.11 ^{ns}	-	-	-	-	-	-
Bali	Ba	-	-	-	-	-	-	-	-	15	8	0.88	0.6	1.05 ^{ns}	-
Bira, Sulawesi	Bi	13	9	0.94	1.5	0.27 ^{ns}	-1.00 ^{ns}	0.03 ^{ns}	0.04 ^{ns}	14	6	0.80	0.6	1.33 ^{ns}	-2.43 ^{ns}
Bangi Islands, Borneo	BI	15	10	0.92	1.6	0.30 ^{ns}	-1.07 ^{ns}	0.01 ^{ns}	0.02 ^{ns}	29	17	0.95	0.9	-0.72 ^{ns}	-0.75 ^{ns}
Biak, New Guinea	Bk	9	9	1.00	1.8	0.10 ^{ns}	-3.44*	0.05 ^{ns}	0.07 ^{ns}	3	2	0.67	0.2	0.00 ^{ns}	-9.44***
Cebu, Visayas	Ce	10	8	0.96	1.7	0.38 ^{ns}	-1.04 ^{ns}	0.02 ^{ns}	0.03 ^{ns}	-	-	-	-	0.20 ^{ns}	0.09 ^{ns}
Donggala, Sulawesi	Do	11	6	0.84	0.8	-0.89 ^{ns}	0.06 ^{ns}	0.05 ^{ns}	0.11 ^{ns}	23	13	0.91	2.8	-2.01*	-1.71 ^{ns}
Karimunjawa, Java	Ka	10	9	0.98	1.9	-0.40 ^{ns}	-2.16 ^{ns}	0.10 ^{ns}	0.06 ^{ns}	2	2	1.00	1.1	0.00 ^{ns}	1.39 ^{ns}
Kendari, Sulawesi	Ke	11	8	0.93	1.9	-0.55 ^{ns}	-0.24 ^{ns}	0.02 ^{ns}	0.06 ^{ns}	17	9	0.89	0.7	-0.57 ^{ns}	-3.00*
Kota Kinabalu, Borneo	KK	6	6	1.00	2.1	-0.27 ^{ns}	-1.16 ^{ns}	0.09 ^{ns}	0.31 ^{ns}	-	-	-	-	-	-
Komodo	Ko	9	8	0.97	1.8	-0.50 ^{ns}	-1.65 ^{ns}	0.02 ^{ns}	0.05 ^{ns}	21	13	0.93	2.8	-2.08**	-2.18 ^{ns}
Kupang, Timor	Ku	8	7	0.96	0.9	-0.33 ^{ns}	-2.26 ^{ns}	0.03 ^{ns}	0.11 ^{ns}	21	12	0.90	0.8	-0.49 ^{ns}	-4.69**
Lembah Strait, Sulawesi	LS	12	10	0.97	1.4	-0.98 ^{ns}	-2.88 ^{ns}	0.01 ^{ns}	0.02 ^{ns}	11	8	0.95	1.1	-0.29 ^{ns}	-1.99 ^{ns}
Luwuk, Sulawesi	Lu	9	8	0.97	1.8	-0.23 ^{ns}	-1.62 ^{ns}	0.05 ^{ns}	0.18 ^{ns}	14	10	0.95	3.9	-1.83*	-0.76 ^{ns}
Manado, Sulawesi	Ma	13	10	0.95	2.2	0.44 ^{ns}	-1.09 ^{ns}	0.01 ^{ns}	0.03 ^{ns}	7	7	1.00	0.9	-0.61 ^{ns}	-3.86**
Misool, Moluccas	Mi	16	13	0.97	2.1	-0.51 ^{ns}	-3.12 ^{ns}	0.04 ^{ns}	0.06 ^{ns}	19	12	0.94	0.9	-1.39 ^{ns}	-5.04**
New Britain, New Guinea	NB	2	2	1.00	1.0	0.00 ^{ns}	1.39 ^{ns}	-	-	-	-	-	-	-	-
Pisang, New Guinea (NG)	Pi	13	11	0.96	1.7	-0.14 ^{ns}	-3.12 ^{ns}	0.02 ^{ns}	0.02 ^{ns}	-	-	-	-	-	-
Pulau Seribu, Java	PS	9	8	0.97	2.3	0.67 ^{ns}	-1.13 ^{ns}	0.03 ^{ns}	0.07 ^{ns}	-	-	-	-	-	-
Sangkalaki, Borneo	Sa	11	9	0.96	1.8	-0.32 ^{ns}	-1.45 ^{ns}	0.01 ^{ns}	0.02 ^{ns}	40	21	0.93	0.9	-1.44 ^{ns}	-11.2***
Sembilan, Sulawesi	Se	-	-	-	-	-	-	-	-	19	14	0.96	0.7	-1.29 ^{ns}	-10.2***
Spermonde, Sulawesi	Sp	52	30	0.95	1.7	-1.05 ^{ns}	-11.88**	0.01 ^{ns}	0.01 ^{ns}	19	15	0.97	0.9	-0.76 ^{ns}	-10.1***
Sebakor/Sanggala/Papisol, New Guinea	SSP	10	9	0.98	0.9	-1.49 ^{ns}	-4.30**	0.04 ^{ns}	0.08 ^{ns}	40	20	0.91	0.8	-1.48 ^{ns}	-12.4***
Togian Islands, Sulawesi	TI	20	13	0.91	1.7	-0.31 ^{ns}	-2.10 ^{ns}	0.03 ^{ns}	0.06 ^{ns}	10	7	0.93	0.8	-0.61 ^{ns}	-2.01 ^{ns}

Historical demography. The null hypothesis of neutral evolution of the marker was tested using Tajima's *D*-test (Tajima 1989) and Fu's *F_s*-test (Fu 1997). Negative Tajima's *D*-values can indicate selection, but also population bottlenecks or population expansions (Tajima 1989). The historical demography was analysed by mismatch distribution (Schneider & Excoffier 1999) of the sum of square deviation (Rogers & Harpending 1992) and Harpending's raggedness index (Harpending 1994), thus testing the model of sudden population expansion (Rogers 1995). The mismatch distribution, which is the distribution of the observed differences between haplotypes, is multimodal in populations under a demographic equilibrium and unimodal if a recent and fast demographic expansion of the population has taken place. All tests were conducted with 10 000 permutations as implemented in the programme Arlequin.

Genetic population structure and connectivity. Analysis of molecular variance (AMOVA; Excoffier et al. 1992) and pairwise ϕ_{ST} -values were used to test for significance of population structure. Both statistical calculations were carried out using the software Arlequin, applying the Tamura-Nei substitution model and gamma shape parameters of 0.3 (*Linckia laevigata*) and 0.2 (*Thyca crystallina*), based on the result obtained with the programmes PAUP (version 4.0b10; Swofford 1998) and Modeltest (version 3.7; Posada & Crandall 1998). Several groupings of *L. laevigata* and *T. crystallina* populations were tested in a hierarchical AMOVA ϕ_{CT} , considering the geography of the region.

Since the coverage of sample sites for the 2 species was different, AMOVA was also conducted with reduced data sets, containing only sites for which samples of both species were available. This was done in order to test if differences in the genetic population structure were due to unequal sampling. Based on an analysis with Modeltest, a gamma shape parameter of 0.2 and the Tamura-Nei substitution model were applied for both species.

Haplotype networks were calculated with the programme TCS (version 1.21; Clement et al. 2000). Clades were defined by the highest number of mutational steps found in a network.

RESULTS

Genetic diversity

Sequence alignments of the COI fragment of 473 and 401 bp lengths were obtained from 270 individuals of *Linckia laevigata* and 324 individuals of *Thyca crystallina*, respectively (Table 1). The observed number of haplotypes was 101 in *L. laevigata* and 68 in *T. crystal-*

lina. The sequences of these haplotypes are available at the EMBL sequence database under the accession numbers FN392698-FN392798 (*L. laevigata*) and FN392799-FN392866 (*T. crystallina*).

Genetic diversity within each population of *Linckia laevigata* showed high levels of haplotype and nucleotide diversity, ranging from 0.84 in the population from Donggala (Sulawesi) to 1.00 in Kota Kinabalu (Borneo), New Britain, and Biak (both New Guinea). Nucleotide diversity was between 0.8% in Donggala and 2.3% in Pulau Seribu (Java Sea) (Table 1).

In *Thyca crystallina*, haplotype diversity was similar to *Linckia laevigata*, but nucleotide diversity was generally lower in most populations. Haplotype diversity in *T. crystallina* ranged between 0.80 in Bira (Sulawesi) to 1.00 in Karimunjawa (Java Sea) and Manado (Sulawesi). Nucleotide diversity was between 0.2 in Donggala and 3.9% in Luwuk (Sulawesi) (Table 1).

Historical demography

The null hypothesis of neutral evolution of the COI marker in *Linckia laevigata* was not rejected for all sample sites based on Tajima's *D*-test, whereas the results of Fu's *F_s*-test rejected the null hypothesis for 3 sites. In *Thyca crystallina*, Tajima's *D*-test rejected the null hypothesis of neutral evolution in 3 cases; Fu's *F_s*-test rejected the null hypothesis in half of the cases. However, this could indicate population expansion in both species, which is supported by the mismatch distribution analysis and Rogers' test of sudden population expansion, except in the population of *T. crystallina* from Manado (Sulawesi) (Rogers 1995; Table 1).

Genetic population structure and connectivity

The evolutionary relationships among 101 *Linckia laevigata* haplotypes and 68 *Thyca crystallina* haplotypes are presented in networks, showing 2 clades in both *L. laevigata* (Fig. 1B) and *T. crystallina* (Fig. 1D). The distribution of clades across the Indo-Malay Archipelago is presented in Fig. 1A, C, respectively.

In *Linckia laevigata*, the 2 clades are separated by 6 mutational steps. The samples from the sites in the Andaman Sea and in Timor consisted only of haplotypes from the black clade, whereas the samples from New Britain and the southwestern coast of New Guinea were presented only by haplotypes of the white clade. All other sites showed haplotypes from both clades, >75% of them dominated by the black clade (Fig. 1A). AMOVA revealed a low fixation index, but significant genetic population structure ($\phi_{ST} = 0.03$, $p = 0.029$) across the Indo-Malay Archipelago. How-

ever, no significant genetic structure was found among sites in the Spermonde Archipelago ($\phi_{ST} = 0.01$, $p = 0.39$). Pairwise ϕ_{ST} -values between sample sites revealed homogeneity among most of them; only 13% showed significant differences (data not shown). A hierarchical AMOVA with several groupings of sample sites was carried out, but only the following rejected the hypothesis of panmixing ($\phi_{CT} = 0.07$, $p = 0.003$): (1) Eastern Indian Ocean (Andaman Sea and Kupang), (2) Western Pacific (Biak, New Britain) and (3) all remaining sites in the central Indo-Malay Archipelago.

The 2 clades in *Thyca crystallina* were separated by 35 mutational steps (Fig. 1D). All sample sites were dominated by the white clade, and haplotypes of the black clade were only present at sample sites from the central Indo-Malay Archipelago (Komodo, Donggala and Luwuk) (Fig. 1C). AMOVA revealed a very low and non-significant fixation index ($\phi_{ST} = 0.005$, $p = 0.24$) across the Indo-Malay Archipelago. Similar to *Linckia laevigata*, most pairwise ϕ_{ST} -values were not significant in *T. crystallina* and only 10% showed restricted gene flow (data not shown). A hierarchical AMOVA did not show any significant groupings of sample sites.

AMOVA of data sets reduced to sites for which samples of both species were available did not show significant population structures for *Linckia laevigata* ($\phi_{ST} = 0.02$, $p = 0.09$) or *Thyca crystallina* ($\phi_{ST} = 0.002$, $p = 0.33$).

DISCUSSION

Genetic diversity

Most populations of the starfish *Linckia laevigata* and its ectoparasite *Thyca crystallina* showed high levels of haplotype diversity. These values are comparable to other studies on invertebrate species in the Indo-Malay Archipelago using COI as a marker, such as the giant clams *Tridacna crocea* (DeBoer et al. 2008, Kochzius & Nuryanto 2008) and *Tridacna maxima* (Nuryanto & Kochzius 2009), as well as the mantis shrimp *Haptosquilla pulchella* (Barber et al. 2002). Nucleotide diversity was generally $>1\%$ in *L. laevigata*, but $<1\%$ in *T. crystallina*, a pattern also observed in another study (Crandall et al. 2008a). Levels of nucleotide diversity $<1\%$ were also detected in giant clams (DeBoer et al. 2008, Kochzius & Nuryanto 2008, Nuryanto & Kochzius 2009) and mantis shrimp (Barber et al. 2002).

Historical demography

The null hypothesis of neutral evolution was rejected by Tajima's *D* and Fu's *F_s* neutrality tests at some sample sites (Table 1), but these tests cannot distinguish be-

tween selection and changes in population size. Demographic growth was indicated by mismatch distribution analysis and Rogers' test of sudden population expansion (Rogers & Harpending 1992, Rogers 1995). Since large shelf areas, such as the Sunda shelf between Java and Borneo, fell dry during several Pliocene and Pleistocene glacial sea level low stands, the extent of coral reef habitats in the Indo-Malay Archipelago and, consequently, population sizes were reduced (Fig. 1). Because of rising sea level in interglacial periods, new habitats could be colonised, resulting in a demographic and spatial population expansion. Signals of population expansion in the Indo-Malay Archipelago have also been observed in another study on *Linckia laevigata* and *Thyca crystallina* (Crandall et al. 2008a), as well as giant clams (Kochzius & Nuryanto 2008, Nuryanto & Kochzius 2009) and the clownfish *Amphiprion ocellaris* (Timm & Kochzius 2008).

Genetic population structure and connectivity

Linckia laevigata showed a rather weak, but significant population structure ($\phi_{ST} = 0.03$) across the Indo-Malay Archipelago. However, analysis of the reduced data set indicated panmixing ($\phi_{ST} = 0.02$). This is probably due to the fact that populations from the margins of the study area, such as the Eastern Indian Ocean, Eastern New Guinea and the Philippines, have been removed. This indicates that there are high levels of gene flow in the central part of the Indo-Malay Archipelago and that populations at the margin are less well connected to the centre. Several studies based on allozyme data also showed low levels of genetic heterogeneity in *L. laevigata* on different geographic scales, ranging from panmixing (Williams & Benzie 1993, 1996) to significant but shallow genetic structures (Williams & Benzie 1998, Magsino et al. 2000, Juinio-Meñez et al. 2003). On large geographic scales in the Indo-West Pacific, PCR-restriction fragment length polymorphism analysis of mitochondrial DNA revealed a more prominent genetic population structure in *L. laevigata* (Williams & Benzie 1997, 1998) compared to the present study. Other invertebrate species, such as giant clams (DeBoer et al. 2008, Kochzius & Nuryanto 2008, Nuryanto & Kochzius 2009) and mantis shrimp (Barber et al. 2002), showed much higher ϕ_{ST} -values for the COI marker than *L. laevigata* in the present study. The less prominent genetic population structure in *L. laevigata* could be due to substantial gene flow resulting from its high dispersal potential (pelagic larval duration [PLD] = 22 d; Yamaguchi 1973). In contrast, the PLD for giant clams is only 9 d (Lucas 1988). A much stronger genetic population structure was also revealed based on other genetic

markers in clownfish ($\phi_{ST} = 0.24$; Timm & Kochzius 2008) with a PLD of 8 to 12 d (Fautin & Allen 1994), and a mushroom coral ($\phi_{ST} = 0.26$; Knittweis et al. 2009) with a PLD of 3 d (Abe 1937).

The significant genetic structure was more pronounced in the hierarchical analysis ($\phi_{CT} = 0.07$) with the following grouping: (1) Eastern Indian Ocean, (2) central Indo-Malay Archipelago and (3) Western Pacific. This pattern of a discontinuity between the Indian and Pacific Oceans was more or less similar in the giant clams *Tridacna crocea* (DeBoer et al. 2008, Kochzius & Nuryanto 2008) and *Tridacna maxima* (Nuryanto & Kochzius 2009), the clownfish *Amphiprion ocellaris* (Timm & Kochzius 2008) and the mushroom coral *Heliofungia actiniformis* (Knittweis et al. 2009). In another study (Crandall et al. 2008a) on *Linckia laevigata*, a genetic break between grouped sites from the (1) Eastern Indian Ocean and (2) the central Indo-Malay Archipelago, as well as the Western Pacific, showed the same ϕ_{CT} -value as the present analysis. Earlier large-scale studies using COI sequences also detected a genetic differentiation between the 2 ocean basins (Williams 2000, Williams et al. 2002). Such a break was also detected in the crown-of-thorns starfish *Acanthaster planci* based on allozymes (Benzie 1999) and COI sequences (Vogler et al. 2008).

This genetic break between the 2 ocean basins was also apparent in the distribution of the black and white clades in *Linckia laevigata*. Two populations in the Indian Ocean (Andaman Sea and Kupang) harboured only individuals carrying haplotypes of the black clade, whereas the populations in the Western Pacific either only consisted of white clade haplotypes (New Britain) or were dominated by them (Biak and Cebu). These clades showed a strong mixing in the central Indo-Malay Archipelago, but the black clade showed a higher frequency in most of the populations (Fig. 1). In contrast to other species that show a main route of dispersal from the Western Pacific into the Eastern Indian Ocean along the path of the ITF (Kochzius & Nuryanto 2008, Timm & Kochzius 2008, Knittweis et al. 2009, Nuryanto & Kochzius 2009), *L. laevigata* seems to enter the Western Pacific from the Eastern Indian Ocean against the ITF. This pattern can also be observed in other studies on *L. laevigata* (Williams et al. 2002, Crandall et al. 2008a). Dispersal against the strong ITF that transports up to 19 million m³ of water per second from the Pacific to the Indian Oceans (Gordon & Fine 1996, Gordon 2005) might be facilitated by seasonally changing currents in Makassar Strait along the coast of Borneo, which are directed to the north in October (Wyrtki 1961; Fig. 1). This coincides with the spawning period of *L. laevigata* in October on Heron Island, Great Barrier Reef (Laxton 1974).

Neither an AMOVA nor hierarchical AMOVA indicated restricted gene flow in *Thyca crystallina* across

the Indo-Malay Archipelago. This species produces in extended breeding periods probably planktonic larvae (Elder 1979) with a high dispersal potential, which is supported by the shallow genetic population structure. This lack of a genetic break between the Indian and Pacific Oceans has also been shown for other species, such as the bigeye tuna *Thunnus obesus* (Alvarado Bremer et al. 1998, Chow et al. 2000), the swordfish *Xiphias gladius* (Chow et al. 1997), the tasslefish *Polynemus sheridani* (Chenoweth & Hughes 2003), the snails *Echinolittorina reticulata* (Reid et al. 2006) and *Nerita plicata* (Crandall et al. 2008b), as well as the sea urchin *Diadema savignyi* (Lessios et al. 2001). However, mechanisms that lead to genetic homogeneity across the Indo-Malay Archipelago are expected to be different among species.

Even though no significant genetic population structure was observed, *Thyca crystallina* showed 2 highly divergent clades that were separated by 35 mutational steps (Fig. 1D). This deep divergence might indicate a cryptic species, but this hypothesis should be verified in an integrative taxonomy approach, including genetic, morphological and ecological data. Such an approach revealed, for instance, a new species of giant clam *Tridacna costata* in the Red Sea (Richter et al. 2008). Similar deep divergences have been observed in the giant clams *Tridacna crocea* (DeBoer et al. 2008, Kochzius & Nuryanto 2008) and *Tridacna maxima* (Nuryanto & Kochzius 2009) across the Indo-Malay Archipelago. It is possible that these 2 divergent clades in *T. crystallina* were affiliated to the Indian and Pacific Oceans, respectively, caused by sea level low stands. After the rise in sea level, the 2 clades came into contact again and the black clade was replaced by the white clade. Even though *Linckia laevigata* and *Thyca crystallina* are codistributed due to a host-parasite relationship, they showed differences in their genetic population structure. This is probably caused by differences in their mode of reproduction, showing that it is not only common ecological and evolutionary processes that are important in shaping the genetic population structure of the 2 species.

Acknowledgements. We thank the institutions and individuals that have made this study possible: German Federal Ministry of Education and Research (BMBF, grant nos. 03F0390B and 03F0427B), which funded this study in the framework of the joint German-Indonesian project SPICE (Science for the Protection of Indonesian Coastal Marine Ecosystems); German Academic Exchange Service (DAAD) for supporting A.N.; Centre for Tropical Marine Ecology (Bremen, Germany) for project coordination, especially C. Richter; GEO Magazine (Hamburg, Germany) for financing the research to Misool and New Guinea; G. Heiss and U. Krumme for providing samples; colleagues from Universitas Hasanuddin (Makassar, Indonesia) for logistical support in Spermonde, especially J. Jompa; and anonymous reviewers for constructive comments. The SPICE

project is conducted and permitted under the governmental agreement between the German Federal Ministry of Education and Research (BMBF) and the Indonesian Ministry for Research and Technology (RISTEK), Indonesian Institute of Sciences (LIPI), Indonesian Ministry of Maritime Affairs and Fisheries (DKP), and Agency for the Assessment and Application of Technology (BPPT). This work was carried out in cooperation with Hassanuddin University (UNHAS, Makassar, Indonesia), Agricultural University Bogor (IPB, Bogor, Indonesia), and Jenderal Soedirman University (Purwokerto, Indonesia).

LITERATURE CITED

- Abe N (1937) Post-larval development of *Fungia actiniformis*. Palao Trop Biol Stn Stud 1:73–79
- Alvarado Bremer JR, Stequert B, Robertson NW, Ely B (1998) Genetic evidence for inter-oceanic subdivision of bigeye tuna (*Thunnus obesus* Lowe) populations. Mar Biol 132: 547–557
- Avise JC (2000) Phylogeography: the history and formation of species. Harvard University Press, Cambridge, MA
- Barber PH, Palumbi SR, Erdmann MV, Moosa MK (2002) Sharp genetic breaks among populations of *Haptosquilla pulchella* (Stomatopoda) indicate limits to larval transport: patterns, causes and consequences. Mol Ecol 11:659–674
- Benzie JAH (1999) Major genetic differences between crown-of-thorns starfish (*Acanthaster planci*) populations in the Indian and Pacific Oceans. Evolution 53:1782–1795
- Bermingham E, Moritz C (1998) Comparative phylogeography: concepts and applications. Mol Ecol 7:367–369
- Bouillon J, Jangoux M (1984) Note sur l'association entre le mollusque parasite *Thyca crystallina* (Gould) (Gasteropoda, Prosobranchia) et l'astéride *Linckia laevigata* (L.) (Echinodermata) sur le récif de l'île de Laing (Papouasie-Nouvelle Guinée). Ann Soc R Zool Belg 114: 249–256
- Briggs JC (1999) Coincident biogeographic patterns: Indo-West Pacific Ocean. Evolution 53:326–335
- Cane MA, Molnar P (2001) Closing of the Indonesian seaway as a precursor to east African aridification around 3–4 million years ago. Nature 411:157–162
- Chao SM (1999) Revision of Taiwan starfish (Echinodermata: Asteroidea), with description of ten new records. Zool Stud 38:405–415
- Chenoweth SF, Hughes JM (2003) Oceanic interchange and nonequilibrium population structure in the estuarine dependent Indo-Pacific tasselfish, *Polynemus sheridani*. Mol Ecol 12:2387–2397
- Chow S, Okamoto H, Uozumi Y, Takeuchi Y, Takeyama H (1997) Genetic stock structure of the swordfish (*Xiphias gladius*) inferred by PCR-RFLP analysis of the mitochondrial DNA control region. Mar Biol 127:359–367
- Chow S, Okamoto H, Miyabe N, Hiramatsu K, Barut N (2000) Genetic divergence between Atlantic and Indo-Pacific stocks of bigeye tuna (*Thunnus obesus*) and admixture around South Africa. Mol Ecol 9:221–227
- Clement M, Posada D, Crandall KA (2000) TCS: a programme to estimate gene genealogies. Mol Ecol 9:1657–1660
- Crandall ED, Jones ME, Muñoz MM, Akinronbi B, Erdmann MV, Barber PH (2008a) Comparative phylogeography of two seastars and their ectosymbionts within the Coral Triangle. Mol Ecol 17:5276–5290
- Crandall ED, Frey MA, Grosberg RK, Barber PH (2008b) Contrasting demographic history and phylogeographical patterns in two Indo-Pacific gastropods. Mol Ecol 17:611–626
- Criscione CD (2008) Parasite co-structure: broad and local scale approaches. Parasite 15:439–443
- DeBoer TS, Subia MD, Ambariyanto, Erdmann MV, Kovitvongsa K, Barber PH (2008) Phylogeography and limited genetic connectivity in the endangered giant boring clam, *Tridacna crocea*, across the Coral Triangle. Conserv Biol 22:1255–1266
- Egloff DA, Smouse D, Pembroke E (1988) Penetration of the radial hemal and perihemal system of *Linckia laevigata* (Asteroidea) by the proboscis of *Thyca crystallina*, an ectoparasitic gastropod. Veliger 30:342–346
- Elder HY (1979) Studies on the host parasite relationship between the parasitic prosobranch *Thyca crystallina* and the asteroid starfish *Linckia laevigata*. J Zool 187: 369–391
- Excoffier L, Smouse PE, Quattro JM (1992) Analysis of molecular variance inferred from metric distances among DNA haplotypes: application to human mitochondrial DNA restriction data. Genetics 131:479–491
- Excoffier L, Laval G, Schneider S (2005) Arlequin (version 3.0): an integrated software package for population genetics data analysis. Evol Bioinform Online 1:47–50
- Fautin DG, Allen GR (1994) Anemonenfische und Ihre Wirte. Tetra-Verlag, Melle
- Folmer O, Black M, Lutz R, Vrijenhoek R (1994) DNA primers for amplification of mitochondrial cytochrome c oxidase subunit I from metazoan invertebrates. Mol Mar Biol Biotechnol 3:294–299
- Froukh T, Kochzius M (2008) Species boundaries and evolutionary lineages in the blue green damselfishes *Chromis viridis* and *C. atripectoralis* (Pomacentridae). J Fish Biol 72:451–457
- Fu YX (1997) Statistical test of neutrality of mutations against population growth, hitchhiking and background selection. Genetics 147:915–925
- Gordon AL (2005) Oceanography of the Indonesian seas and their throughflow. Oceanography 18:14–27
- Gordon AL, Fine RA (1996) Pathways of water between the Pacific and Indian Oceans in the Indonesian seas. Nature 379:146–149
- Hall R (1998) The plate tectonics of Cenozoic SE Asia and the distribution of land and sea. In: Hall R, Holloway JD (eds) Biogeography and geological evolution of SE Asia. Backhuys Publishers, Leiden, p 99–131
- Hall TA (1999) BioEdit: a user-friendly biological sequence alignment editor and analysis program for Windows 95/98/NT. Nucleic Acids Symp Ser 41:95–98
- Harley CDG, Pankey MS, Wares JP, Grosberg RK, Wonham MJ (2006) Color polymorphism and genetic structure in the sea star *Pisaster ochraceus*. Biol Bull 211:248–262
- Harpending HC (1994) Signature of ancient population growth in a low-resolution mitochondrial DNA mismatch distribution. Hum Biol 66:591–600
- Hoeksema BW (2007) Delineation of the Indo-Malayan centre of maximum marine biodiversity: the coral triangle. In: Renema W (ed) Biogeography, time and place: distributions, barriers and islands. Topics in Geobiology, Vol 29. Springer, Dordrecht, p 117–178
- Janssen HH (1985) Three epizoic gastropods from Malaysia and the Philippines. Parasitol Res 71:553–560
- Juinio-Meñez MA, Magsino RM, Ravago-Gotanco R, Yu ET (2003) Genetic structure of *Linckia laevigata* and *Tridacna crocea* populations in the Palawan shelf and shoal reefs. Mar Biol 142:717–726
- Knittweis L, Krämer WE, Timm J, Kochzius M (2009) Genetic structure of *Heliofungia actiniformis* (Scleractinia: Fungiidae) populations in the Indo-Malay Archipelago: implications for live coral trade management efforts. Conserv Genet 10:241–249

- Kochzius M, Nuryanto A (2008) Strong genetic population structure in the boring giant clam *Tridacna crocea* across the Indo-Malay Archipelago: implications related to evolutionary processes and connectivity. *Mol Ecol* 17: 3775–3787
- Kochzius M, Söller R, Khalaf MA, Blohm D (2003) Molecular phylogeny of the lionfish genera *Dendrochirus* and *Pterois* (Scorpaenidae, Pteroinae) based on mitochondrial DNA sequences. *Mol Phylogenet Evol* 28:396–403
- Krantz DE (1991) A chronology of Pliocene sea-level fluctuations: the US middle Atlantic coastal plain record. *Quat Sci Rev* 10:163–174
- Laxton JH (1974) A preliminary study of the biology and ecology of the blue starfish *Linckia laevigata* (L.) on the Australian Great Barrier Reef and an interpretation of its role in the coral reef ecosystem. *Biol J Linn Soc* 6:47–64
- Lessios HA, Kessing BD, Pearse JS (2001) Population structure and speciation in tropical seas: global phylogeography of the sea urchin *Diadema*. *Evolution* 55: 955–975
- Lucas JS (1988) Giant clams: description, distribution and life history. In: Copland JW, Lucas JS (eds) *Giant clams in Asia and the Pacific*. Australian Centre for International Agricultural Research, Canberra, p 21–32
- Magsino RM, Juinio-Meñez MAR, Ravago RV (2000) Development and application of genetic markers for population structure analysis of the blue coral reef starfish, *Linckia laevigata* (Linn.) (Echinodermata: Asteroidea). *Sci Diliman* 12:10–16
- Nei M (1987) *Molecular evolutionary genetics*. Columbia University Press, New York
- Nei M, Jin L (1989) Variances of the average numbers of nucleotide substitutions within and between populations. *Mol Biol Evol* 6:290–300
- Nuryanto A, Kochzius M (2009) Highly restricted gene flow and deep evolutionary lineages in the giant clam *Tridacna maxima*. *Coral Reefs* 28:607–619
- Posada D, Crandall KA (1998) Modeltest: testing the model of DNA substitution. *Bioinformatics* 14:817–818
- Reid DG, Lal K, Mackenzie-Dodds J, Kaligis F, Littlewood DTJ, Williams ST (2006) Comparative phylogeography and species boundaries in *Echinolittorina* snails in the central Indo-West Pacific. *J Biogeogr* 33:990–1006
- Richter C, Roa-Quiaioit H, Jantzen C, Al-Zibdah M, Kochzius M (2008) Collapse of a new living species of giant clam in the Red Sea. *Curr Biol* 18:1349–1354
- Rogers AR (1995) Genetic evidence for Pleistocene population expansion. *Evolution* 49:608–615
- Rogers AR, Harpending H (1992) Population growth makes waves in the distribution of pairwise genetics differences. *Mol Biol Evol* 9:552–569
- Rohling EJ, Fenton M, Jorissen FJ, Bertrand P, Ganssen G, Caulet JP (1998) Magnitudes of sea-level lowstands of the past 500,000 years. *Nature* 394:162–165
- Schneider S, Excoffier L (1999) Estimation of past demographic parameters from distribution of pairwise differences when the mutation rates vary among sites: application to human mitochondrial DNA. *Genetics* 152: 1079–1089
- Siddall M, Rohling EJ, Almogi-Labin A, Hemleben C, Meischner D, Schmelzer I, Smeed DA (2003) Sea-level fluctuations during the last glacial cycle. *Nature* 423:853–858
- Sloan NA, Clark AM, Taylor JD (1979) The echinoderms of Aldabra and their habitats. *Bull Br Mus (Nat Hist)* 37: 81–128
- Swofford DL (1998) PAUP*: phylogenetic analysis using parsimony (and other methods). Version 4.0b10. Sinauer & Associates, Sunderland, MA
- Tajima F (1989) Statistical method for testing the neutral mutation hypothesis by DNA polymorphism. *Genetics* 123:585–595
- Thompson JD, Higgins DG, Gibson TJ (1994) Clustal W: improving the sensitivity of progressive multiple sequence alignments through sequence weighting, position specific gap penalties and weight matrix choice. *Nucleic Acids Res* 22:4673–4680
- Timm J, Kochzius M (2008) Geological history and oceanography of the Indo-Malay Archipelago shape the genetic population structure in the false clown anemonefish (*Amphiprion ocellaris*). *Mol Ecol* 17:3999–4014
- Timm J, Figiel M, Kochzius M (2008) Contrasting patterns in species boundaries and evolution of anemonefishes (Amphiprioninae, Pomacentridae) in the centre of marine biodiversity. *Mol Phylogenet Evol* 49:268–276
- Troncoso JS, Van Goethem J (1998) Nuevos datos sobre la asociación de *Stilifer linckiae* y *Thyca crystallina* (Mollusca, Eulimidae) con *Linckia laevigata* (Linnaeus, 1758) (Echinodermata, Asteroidea) en la Isla de Laing (Bahía de Hansa, Provincia de Madang, N de Papua-Nueva Guinea). *NACC Nova Acta Cient Compostel Biol* 8: 201–208
- Vogler C, Benzie J, Lessios H, Barber P, Wörheide G (2008) A threat to coral reefs multiplied? Four species of crown-of-thorns starfish. *Biol Lett* 4:696–699
- Voris HK (2000) Maps of Pleistocene sea levels in Southeast Asia: shorelines, river systems and time duration. *J Biogeogr* 27:1153–1167
- Walsh PS, Metzger DA, Higushi R (1991) Chelex 100 as a medium for simple extraction of DNA for PCR-based typing from forensic material. *Biotechniques* 10:506–513
- Warén A (1980) Revision of the genera *Thyca*, *Stilifer*, *Scalenostoma*, *Mucronalia* and *Echineulima* (Mollusca, Prosobranchia, Eulimidae). *Zool Scr* 9:187–210
- Williams ST (2000) Species boundaries in the starfish genus *Linckia*. *Mar Biol* 136:137–148
- Williams ST, Benzie JAH (1993) Genetic consequences of long larval life in the starfish *Linckia laevigata* (Echinodermata: Asteroidea) on the Great Barrier Reef. *Mar Biol* 117:71–77
- Williams ST, Benzie JAH (1996) Genetic uniformity of widely separated populations of the coral reef starfish *Linckia laevigata* from the East Indian and West Pacific Oceans, revealed by allozyme electrophoresis. *Mar Biol* 126: 99–107
- Williams ST, Benzie JAH (1997) Indo-West Pacific patterns of genetic differentiation in the high-dispersal starfish *Linckia laevigata*. *Mol Ecol* 6:559–573
- Williams ST, Benzie JAH (1998) Evidence of a biogeographic break between populations of a high dispersal starfish: congruent regions within the Indo-West Pacific defined by color morphs, mtDNA, and allozyme data. *Evolution* 52:87–99
- Williams ST, Jara J, Gomez N, Knowlton N (2002) The marine Indo-West Pacific break: contrasting the resolving power of mitochondrial and nuclear genes. *Integr Comp Biol* 42:941–952
- Wyrtki K (1961) *Physical oceanography of the Southeast Asian waters*. University of California, La Jolla
- Yamaguchi M (1973) Early life histories of coral reef asteroids, with special reference to *Acanthaster planci* (L.). In: Jones OA, Endean R (eds) *Biology and geology of coral reefs*. Academic Press, New York and London, p 369–387
- Yamaguchi M (1977) Population structure, spawning, and growth of the coral reef asteroid *Linckia laevigata* (Linnaeus). *Pac Sci* 31:13–30



Macrophytes as habitat for fauna

Hartvig Christie^{1,*}, Kjell Magnus Norderhaug¹, Stein Fredriksen²

¹Norwegian Institute for Water Research, Gaustadalleen 21, 0349 Oslo, Norway

²Department of Biology, University of Oslo, PO Box 1069 Blindern, 0316 Oslo, Norway

ABSTRACT: Macrophyte systems, including kelp, seaweed and seagrasses, have revealed high diversity and abundance of associated fauna along the Norwegian coast. In the present study, data from a number of recent studies were assembled and supplemented with new data to elucidate the organisation of macrofaunal diversity on macrophytes. The aim was to compare faunal composition on macrophytes of different size, shape, longevity and function. Macrofaunal densities frequently exceed 100 000 individuals m⁻² in macrophyte beds. Commonly, high densities of amphipods and gastropods are found. The faunal composition depends mainly on habitat architecture at a spatial micro-scale, while faunal abundances depend on habitat size. These 2 patterns are consistent over larger spatial scales. Most faunal species show high mobility and dispersal rates, and they colonize available habitats rapidly. Macrophyte longevity may, in some cases, influence faunal composition. The macrophytes function both as a habitat and as a food source, but the feeding behaviour of the majority of the faunal components prevents the fauna from overgrazing their habitat and thus destroying the primary producer and foundation species of the community. The perennial macrophytes are mainly consumed as particulate organic matter. A high functional redundancy in both plants and animals is most likely important for the stability of the macrophyte system. The stability and diversity of macrophyte systems are found to be threatened in various ways by overgrazing, removal by storms and commercial harvesting, eutrophication and overfishing of top predators, with concurrent challenges for management.

KEY WORDS: Macroalgae · Seagrass · Fauna · Diversity · Stability

Resale or republication not permitted without written consent of the publisher

INTRODUCTION

Macrophytes are important primary producers along coasts worldwide, serving as habitat or functioning as ecological engineering species. Seaweed, kelp and seagrasses form small patches or larger vegetation beds which support epiphytic algae and animals, as well as a variety of associated mobile animals, including meiofauna, macrofauna and fish. There have been a number of studies on macrophytes as habitats, but they mainly focus on fauna associated with single species of small red algae (e.g. Dommasnes 1969, Norderhaug 2004), seaweeds (Colman 1940, Hagerman 1966, Edgar 1991), kelps (Jones 1971, Moore 1973, 1986, Edwards 1980, Schultze et al. 1990, Christie et al. 2003) or seagrasses (e.g. Nelson, 1980, Baden & Phil 1984, Edgar 1990, Baden & Boström 2000). It is unknown whether the same faunal species are associated with all macrophytes in a

coastal area, or whether macrophyte systems of high complexity support a higher diversity of fauna than less complex systems. Macrophytes differ in size, architectural structure and longevity. Differences in structural qualities of the habitat may affect its value as a refuge from predators (Martin-Smith 1993) and wave action (Fenwick 1976). Different animals prefer different substrates (Hacker & Steneck 1990, Norderhaug 2004, Christie et al. 2007), and structural differences between macrophyte communities may affect faunal species composition. All macrophytes provide habitats of limited duration, while most faunal species have a lifespan of approximately 1 yr. Small turf algae may live for some months, and although furoid, seagrass and kelp beds persist for many years, the turnover time of leaves or laminas may vary from weeks to months. The faunal species composition on macrophytes may thus be affected by macrophyte longevity and faunal colonisation rates.

*Email: hartvig.christie@niva.no

In addition to being important habitats for many organisms, macrophytes are important primary producers in coastal ecosystems, and are therefore a potential food resource for the associated animals. Overgrazing sometimes occurs, showing that grazers have the potential to consume their habitat. Most attention has been given to sea urchins grazing seaweeds, kelps and seagrasses (Lawrence 1975, Norderhaug & Christie 2009). The removal of the habitat-forming species leads to collapse of the ecosystem and a new ecological state (Elner & Vadas 1990). Thus, it is important for the persistence of the system that the grazers do not overexploit their habitat. On the other hand, a reduction in small grazers may lead to overgrowth by epiphytic algae and cause severe effects on the habitat-forming macrophytes (Moksnes et al. 2008). Both overgrazing and overgrowth by epiphytes are unusual events, and this suggests that self-regulation occurs in healthy macrophyte systems. Important factors for self-regulation may include food supply and predator refuge for grazers, feeding habits of the grazer and predation pressure, and persistence and resilience are expected to be dependent on diversity within the important functional groups (high functional redundancy, Duffy et al. 2001, 2003, Steneck et al. 2002).

A number of macrophyte species have a wide geographical distribution in the northeast Atlantic. Most fucoids, kelps and the seagrass *Zostera marina* L. are widely distributed from southern Europe to north of the polar circle. The Norwegian coastline, with fjords and islands, equals a distance of 2 times around the equator (83 000 km) and thus contributes to a significant part of the total European shoreline. The Norwegian coastline is dominated by intertidal and subtidal hard bottoms. These comprise substrate for large areas of diverse macroalgal beds from the shore down to 20 to 30 m depth, altogether estimated to cover an area greater than 10 000 km². Thus, it is important to identify the role of macrophyte beds as habitats for other organisms, and the Norwegian coast provides an opportunity to compare a variety of macrophytes over small and large spatial scales.

Four different functional groups of macrophytes dominate shallow coastal areas in Norway: fucoids, turf algae, kelp and seagrass. Fucoids are perennial, mostly intertidal species that create a 3-dimensional habitat by being upright during high tide. They form dense beds with a canopy height of 0.5 to 1 m and are structurally uniform. Fucoids provide shelter and moist conditions by covering the rocky shores when the tide is out. Some fucoids, including *Fucus serratus* L., may dominate the sublittoral zone to depths of 3 to 4 m (Fredriksen & Christie 2003). Estimates of primary production of fucoids are in the range 300 to 1300 g C m⁻² yr⁻¹ (Lüning 1990, Barrón et al. 2003).

Turf algae include a high number of red, green and brown algal species which are common from the littoral zone down to about 30 m depth. These are either annual algae occurring during the summer (many green and brown filamentous) or perennial species with reduced size during winter (many red algae species). Turf algae are small and may vary structurally from complex to uniform. In southern Norway, large areas of sugar kelp *Saccharina latissima* (L.) C.E. Lane, C. Mayes, Druehl & G.W. Saunders beds in protected areas have been replaced by turf algae (Moy et al. 2008).

Kelp beds are large and structurally complex habitats consisting of perennial species. The dominant macrophyte species along the wave-exposed Norwegian coast is the kelp *Laminaria hyperborea* (Gunn.) Foslie. This species is characterized by having an annual lamina and a perennial stipe and holdfast that may reach an age of more than 20 yr (Sjötun et al. 1995), while ~10 yr is a more usual longevity. The 1 to 3 m-long stipe is important for a number of associated epiphytic algae that will contribute to the total primary production in such kelp beds. The number of different epiphytic algal species recorded is in the range of 30 to 45 (Jorde 1966, Marstein 1997). Estimates of primary production in kelp forests are in the range of 1200 to 1900 g C m⁻² yr⁻¹. However, even higher numbers have been suggested (Abdullah & Fredriksen 2004).

Seagrass beds may last for many years, while seagrass leaves are short-lived. According to Pinnerup (1980), the leaves are renewed several times each summer. Seagrasses are found in shallow bays on sandy or muddy substrate. The dominant bottom type along the Norwegian coast is rocky shore, therefore seagrass beds are scattered within locations where soft bottoms are present. The dominant seagrass in Norway is *Zostera marina* (eelgrass). Investigations have shown that seagrasses and fucoids may be heavily overgrown by epiphytes (Fredriksen et al. 2005), and about 100 species of epiphytic algae have been found in these systems. Seagrass beds are also considered to be productive areas. According to Lüning (1990), they may produce up to 1000 g C m⁻² yr⁻¹.

In the present study, we combined data from a number of recently published studies and supplemented this with new data to compare the macrofauna composition on different types of macrophytes. One aim was to test similarities and dissimilarities in the fauna composition associated with macrophytes of different sizes, shapes and longevity, i.e. seagrass, fucoids, turf algae and kelp. Another aim was to analyse the functional importance of different macrophytes as habitats and carbon sources to associated fauna. These analyses should enable us to better understand regulatory processes responsible for the high persistence of macro-

phyte communities on the Norwegian coast. The data used are from a number of field studies and manipulations, mesocosm studies and laboratory experiments.

MATERIALS AND METHODS

For identification of fauna associated with habitat-forming macrophytes, we sampled whole or parts of plants with associated organisms *in situ* by SCUBA. Sampling took place along a coastline of more than 1000 km, between 58 and 64°N, and in 4 regions: Region 1, the Norwegian south coast between 58 and 59°N; Region 2, the west coast at about 60°N; Region 3, the west coast at about 63°N; and Region 4, at 64°N. Table 1 lists the species of macrophytes we focused on and in which region they were sampled. Faunal data from *Laminaria hyperborea* (Christie et al. 2003), *Zostera marina* and *Fucus serratus* samples from 2000 (Fredriksen & Christie 2003, Fredriksen et al. 2005) have been previously described. In the case of the large kelp *L. hyperborea*, we sampled holdfasts, stipes (with epiphytes) and laminas separately, because they represent different habitat structures. Smaller kelps

(*Saccarina latissima*) and fucoids were sampled individually, while turf algae and above-ground seagrasses were sampled by use of frames (20 × 20 or 50 × 50 cm, see Fredriksen et al. 2005). Macrophytes were carefully sampled and enclosed in fine mesh cotton bags and sealed *in situ*. Habitat size was determined by measuring displacement volume or wet weight of the macrophytes (1 ml displacement = 1 g wet weight). We then collected the fauna by washing and sieving (mesh size 250 µm). The number of animals were counted and identified to species or the lowest possible taxonomic level. By this method we collected a representative sample of mobile animals, while sessile animals were less represented and were not a focus of the analyses in the present study. Faunal densities are reported as number of individuals related to size or wet weight of the macrophyte, and also as numbers per m² for those sampled in quadrates. For estimations of faunal densities on macrophytes where single plants were sampled, we estimated *L. hyperborea*, *Ascophyllum nodosum* (L.) Le Jol. and *Sargassum muticum* (Yendo) Fensholt to densities of 10 plants m⁻², and *Fucus* spp. and *Saccharina latissima* to 25 m⁻² (based on authors' unpubl. data). These estimates provide conservative

Table 1. Mean (SE) and total number of fauna species in the macrophyte samples. Each sample consists of 3 or 4 replicate macrophyte individuals or quadrates (see 'Materials and methods') except for *Sargassum muticum*, where only 1 plant has been sampled. An estimate of mean (SE) faunal density (total no. animals m⁻²) is given based on extrapolations described in 'Materials and methods'

Macrophyte species	Site (region)	Year	Month	Mean number	Total number	Mean fauna density
<i>Laminaria hyperborea</i>	Froan V3 (4)	1993	8	88 (1.0)	103	621863 (113650)
	Froan V2 (4)	1993	8	72 (5.3)	107	24680 (5030)
	Froan V1 (4)	1993	8	60 (2.4)	92	15320 (4150)
	Seterøy (3)	1995	8	89 (2.8)	132	55500 (9490)
	Kvaløy (3)	1995	8	84 (3.8)	106	84273 (14741)
	Kvaløy (3)	1996	9	96 (0)	119	126596 (23656)
	Bergen (2)	1997	9	96 (4.6)	125	12783 (2123)
	Arendal (1)	1996	8	71 (7.0)	90	25700 (205)
<i>Saccharina latissima</i>	Arendal (1)	1996	8	42 (6.0)	62	110725 (18125)
<i>Fucus serratus</i>	Arendal (1)	1996	8	34 (5.2)	56	172450 (96600)
	Arendal (1)	2000	9	37 (7.4)	51	33625 (11400)
	Arendal (1)	2000	9	60 (5.3)	86	378250 (129 475)
<i>Ascophyllum nodosum</i>	Arendal (1)	1996	8	30 (3.7)	50	34920 (14 370)
<i>Sargassum muticum</i>	Arendal (1)	1996	8	–	37	681580
<i>Ceramium rubrum</i>	Arendal (1)	1996	8	24 (1.7)	44	115300 (27450)
<i>Rhodomela confervoides</i>	Arendal (1)	1996	8	37 (2.3)	67	143475 (13500)
<i>Scagelia</i> sp.	Arendal (1)	1996	5	25 (3.0)	50	8475 (3650)
<i>Spongomorpha</i> sp.	Arendal (1)	1996	5	17 (2.4)	35	8625 (3650)
<i>Zostera marina</i>	Arendal (1)	1996	8	43 (1.7)	70	31012 (1444)
	Arendal (1)	2000	9	72 (9.7)	110	12188 (1164)
	Arendal (1)	2000	9	54 (2.5)	75	53832 (5764)
<i>Fucus vesiculosus</i>	Hopavåg (4)	1998	8	23 (2.4)	33	21200 (7133)
	Hopavåg (4)	1998	10	19 (2.9)	27	19041 (7798)
<i>Saccharina latissima</i>	Grimstad (1)	2008	8	35 (4.0)	49	22750 (6536)
	Bergen (2)	2008	8	48 (8.3)	64	75832 (27122)
Mixed red turf algae	Arendal (1)	2005	8	24 (1.5)	35	23508 (4275)
	Arendal (1)	2008	8	27 (3.5)	36	32083 (13787)
Mixed brown turf algae	Hyllestad (2)	2005	8	33 (1.2)	45	11617 (2193)
	Bergen (2)	2008	8	31 (1.5)	42	30108 (6043)

data as we only recorded adult plants, not including juvenile understory vegetation and epiphytes.

Faunal mobility, colonisation rates, habitat preferences and habitat use were studied by use of artificial substrates exposed *in situ* for different time periods (hours to weeks) within and outside macrophyte beds (Kraufvelin et al. 2002, Norderhaug et al. 2002, 2007, Jørgensen & Christie 2003, Waage-Nielsen et al. 2003, Christie et al. 2007).

Different mimics and/or artificial substrates were used to imitate different algal structures (Christie et al. 2007). A small experiment with artificial substrate in a fjord overgrazed by sea urchins was performed to study colonization of fauna in an area completely cleared of sublittoral macrophytes (new data presented here from the Porsanger fjord). Trophic relationships were studied with feeding experiments of mesograsers in smaller aquarium tests (Norderhaug et al. 2003, Christie & Kraufvelin 2004, Kraufvelin et al. 2006a). Food chain analyses were performed using data from gillnet fishing and analysis of fish stomach contents and stable carbon isotope ratios (Fredriksen 2003, Norderhaug et al. 2003, 2005). Experimental tests of the functional relationships between seaweeds and associated fauna were performed in large intertidal mesocosms (Bokn et al. 2003, Kraufvelin et al. 2006b); these focused on fauna composition related to effects of eutrophication. We also had the opportunity to test the effects of physical disturbance on macrophytes by field sampling in areas trawled by commercial kelp harvesting (Christie et al. 1998).

Multidimensional scaling (MDS) (Shepard 1962, Kruskal 1964a,b) followed by SIMPER was used to analyse differences in the faunal composition between samples. Ordinations and clusters were based on similarity matrices using the PRIMER 5.2.1 computer package (Clarke 1993). We used the Bray-Curtis similarity index (Bray & Curtis 1957) and all data were log-transformed.

RESULTS AND DISCUSSION

Animal abundance and habitat size

Although there was variation between samples, there was a generally positive correlation between animal abundance and habitat size across all macrophyte species and regions. Fauna densities on kelps, furoids, turf algae and seagrass are listed in Table 1. Except for a few seasonal algae occurring only in the spring, the samples were taken in late summer when fauna abun-

Table 2. Epiphytic macrophytes from the kelp *Laminaria hyperborea*, site of collection, total number and abundance (ind. 100 g⁻¹, SE) of faunal species (n = 6)

Macrophyte species	Site, region 3	Year	Month	Total no. species	Faunal abundance (SE)
<i>Palmaria palmata</i>	Finnøy	2006	8	20	639 (69)
<i>Callophyllis laciniata</i>	Finnøy	2006	8	33	3580 (279)
<i>Phycodrys rubens</i>	Finnøy	2006	8	43	2924 (1089)
<i>Polysiphonia elongata</i>	Finnøy	2006	8	26	1196 (302)
<i>Rhodomela</i> sp.	Finnøy	2006	8	40	4508 (509)
<i>Ptilota gunneri</i>	Finnøy	2006	8	39	4379 (616)

dances peak (Christie et al. 2003). Variation in correlations between habitat size and animal abundances is probably partly due to the method used in calculating habitat volume, because the habitat does not only consist of the algal surface, but also the interstitial volume (Hacker & Steneck 1990). Animal density per 100 g of 6 epiphytic red algae on kelp stipes (Table 2) was higher on complex than structurally simple algae. *Palmaria palmata* (L.) Kuntze, with smooth surfaces, housed lower densities than the structurally more complex *Rhodomela* sp. and *Ptilota gunneri* P.C. Silva, Maggs & L.M. Irvine.

The highest macrofauna densities and largest habitat sizes were found in kelp forests in exposed coastal areas in mid-Norway: average fauna densities exceeded half a million animals per m² (Stn Froan V3, Table 1). The highest number of animals found on a single kelp occurred on the largest of the 4 replicate kelps from Stn Froan V3, which housed about 90 000 specimens. Kelp size and epiphyte volume increased with increasing wave exposure (Christie et al. 1998, 2003), which led to higher numbers of associated animals. At the Froan stations, which represent an exposure gradient, the kelp at the most exposed station, V3, was largest in size and had larger epiphytes (see Christie et al. 2003) and higher densities of animals than the moderately and less exposed Stns V2 and V1, respectively. Christie et al. (2003) also found a significant positive correlation between kelp size and fauna abundance within kelp plants sampled at the same site at Finnøy in Region 3, but no correlation between kelp size and number of associated animal species. To test the effect of habitat volume independently of macrophyte food value or differences in habitat complexity, we performed field experiments using uniform artificial habitat of different sizes (Norderhaug et al. 2007). We found that the faunal abundance increased with increasing habitat volume (Fig. 1). The increase in habitat size did not result in any significant increase in number of species. The increase in faunal abundance with increasing natural and artificial habitat size (volume) indicates that there is a strong need for habitats among the macrophyte fauna; the correlation between

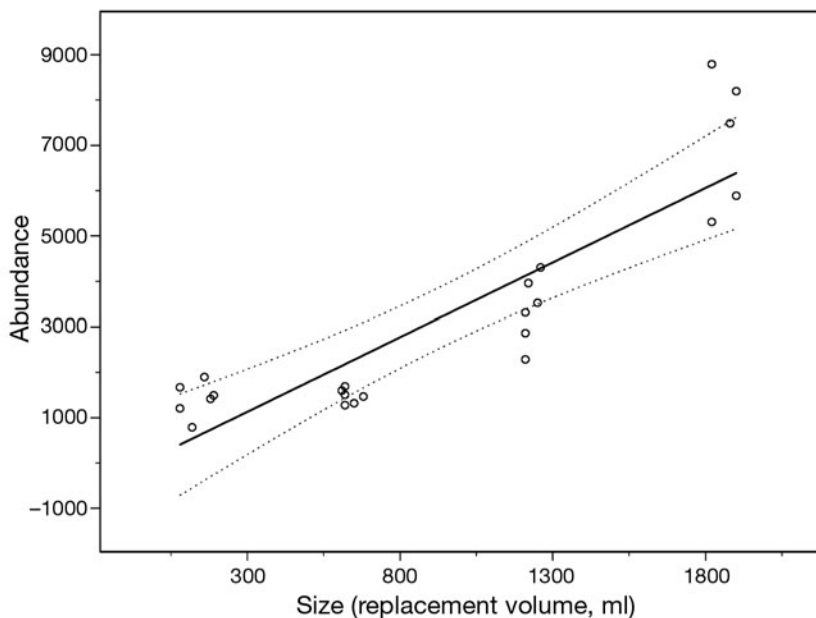

Fig. 1. Abundances (no. specimens) of mobile macrofauna in relation to habitat size (measured as replacement volume, ml) ($\pm 95\%$ CI) sampled on different natural (epiphytic red algae) and artificial (rope bundles) habitats. The samples grouped to the left in the plot (i.e. the samples with the lowest size) are natural habitats. The larger samples are samples with natural habitat and respectively one, two or three additional rope bundles, each of 600 ml. Data from Norderhaug et al. (2007)

faunal abundance and artificial habitat volume particularly indicates that habitat (and not food) is a limited resource in these systems.

Many of the sampled macrophyte communities had densities of about 100 000 animals m^{-2} . The lowest faunal densities (and also lowest species richness) were found in ephemeral turf algae of small size and low habitat complexity. These turfs dominated protected areas after disappearance of sugar kelp in southern Norway (Moy et al. 2008). Low densities of animals in these turf samples may also be due to high grazing pressures by small fish, since Moy et al. (2008) observed very high densities of Labridae and Gobiidae. Faunal densities were also lower in intertidal algae (like *Fucus vesiculosus*) than in structurally similar submerged species. This is expected since the littoral zone is a physically harsher environment than the sublittoral zone.

Animal diversity and habitat structure

While animal abundances correlated with habitat size, species richness was dependent on habitat structure. More species were associated with algae of high structural complexity (Tables 1 & 2; for further details see Christie et al. 2003, 2007). Further, the associated

faunal composition seems to be dependent on macrophyte form or structurally similar species. A comparison of faunal composition on 9 species of macrophytes (*Laminaria hyperborea* separated into holdfast, stipes and lamina) sampled at the same area (see Table 1) showed similarity (grouping) of 3 replicate samples within each macrophyte species (or kelp part), while the different macrophytes are separated (Fig. 2). The SIMPER test revealed that the most common (and ubiquitous) faunal species to a great extent explained both similarities and differences between the associated faunal communities on the different macrophytes, indicating that these species are present on most macrophytes, but at different scales of abundance. A consistent, common pattern of dominance of crustaceans and molluscs was found. However, the different macrophytes housed different numbers of species (Table 1) as well as different species (see below). Structurally similar species such as kelps and fucoids housed a rich faunal community and many similar species (e.g. *Rissoa parva* da Costa). The *Zostera marina* samples were also species-rich and housed other species of gastropods and amphipods (see below [p. 237]) and some species which may be more related to soft bottom habitats. Many of the turf algae are structurally uniform and the associated faunal communities were species-poor.

Fig. 3 shows an MDS plot of fauna on *Laminaria hyperborea* holdfast, stipes and lamina sampled at the 4 different regions of the Norwegian coast. The faunal composition differed between the 3 different parts of the kelp. Laminas from Region 1 are positioned close to the stipes. These laminas were overgrown by epiphytic red algae similar to that which had overgrown the stipes, and were thus structurally similar to the stipes. The faunal composition from each kelp part was similar across all 4 regions. This shows that the physical structure of the habitat is a more important factor than latitude (gradual change in species composition; vertically in plot) for the faunal community structure. Norderhaug et al. (2002) distinguished between holdfast fauna, stipe fauna and ubiquitous fauna, and SIMPER analysis from the present study shows which species contributed most in distinguishing between lamina, stipes and holdfast faunal assemblages (horizontally in the plot). While gastropods such as *Gibbula cineraria* (L.), *Ansates pellucida* (L.) and *Lacuna vincta*

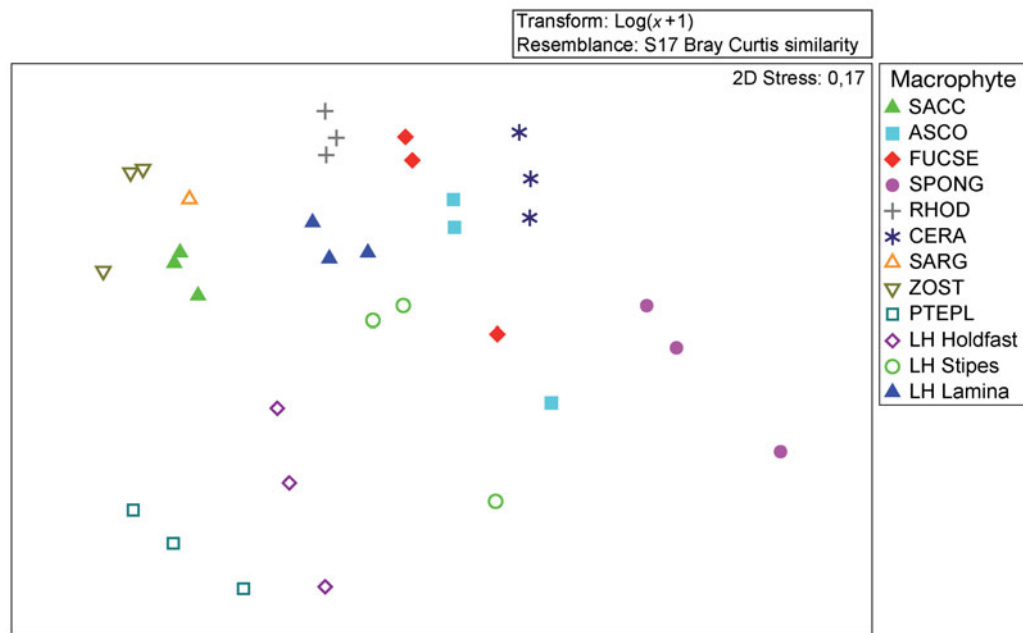

Fig. 2. Multidimensional scaling plot of fauna from 3 replicate samples of 10 different macrophytes sampled at Arendal in 1996. Differences in faunal composition between the macrophyte host species are shown. SACC: *Saccharina latissima*; ASCO: *Asco-phylum nodosum*; FUCSE: *Fucus serratus*; SPONG: *Spongomorpha* sp.; RHOD: *Rhodomela confervoides*; CERA: *Ceramium rubrum*; SARG; *Sargassum muticum* (only 1 sample); ZOST: *Zostera marina*; PTEPL: *Pterothamnion plumula*; LH: *Laminaria hyperborea* (holdfast, stipes, lamina separated)

(Montagu) dominated on the smooth lamina, mobile amphipods like *Jassa falcata* (Montagu), *Apherusa jurinei* (Milne-Edwards) and *A. bispinosa* (Bate) and rissoidae gastropods dominated the stipes, and more sedentary amphipods like *Corophium bonelli* (G.O. Sars) and burrowing polychaetes and mussels like *Hiatella arctica* (L.) dominated the holdfasts.

Sampling of individual epiphytic algae and comparisons with different mimics showed that the faunal composition differed between rough, bushy and smooth substrate regardless of whether the sample was algae or a mimic (Fig. 4; Christie et al. 2007). Also, samples of *Zostera marina* and *Fucus serratus* from different sites showed a high degree of similarity in epiphyte and

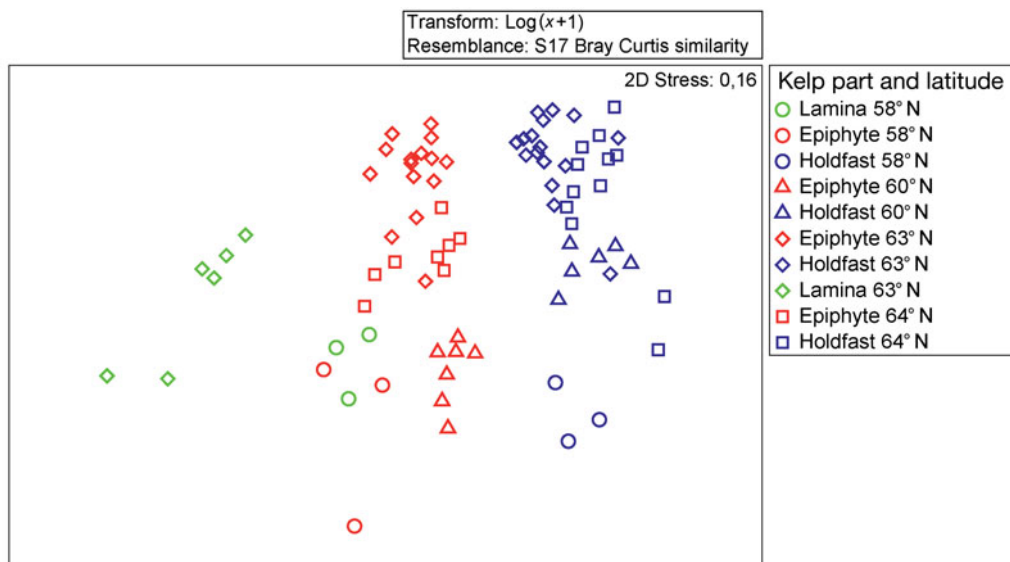

Fig. 3. Multidimensional scaling plot reflecting faunal composition on kelp lamina, holdfasts and epiphytic red algae on the kelp stipes from different regions on the Norwegian coast. Data from Christie et al. (2003)

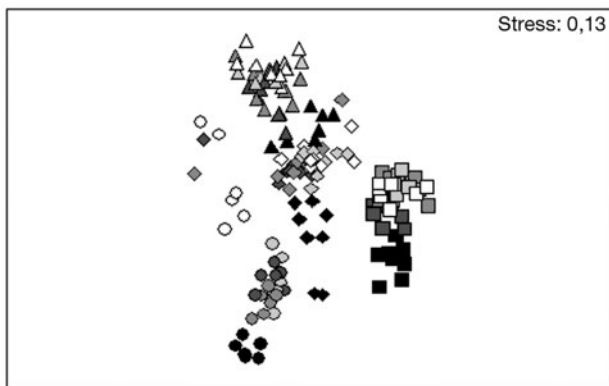

Fig. 4. Multidimensional scaling plot of faunal composition in kelp parts and mimics. Symbols indicate different substrates—circles: kelp parts; squares: bushy mimics; diamonds: rough mimics; triangles: smooth mimics. For each substrate, filled black symbols indicate the bottom level, grey shading the middle level (lighter at higher positions), and unfilled symbols the top level. For the kelp plants, black is used for the hold-fast, shading for stipe sections with epiphytes and white for the lamina. Data from Christie et al. (2007)

faunal content within macrophyte species (Fig. 5). Differences between associated organisms on these 2 macrophytes were clear even though they were sampled only a few meters apart at each station, and even though both macrophytes have relative smooth surfaces. More than 200 macrofaunal species have been identified in these 2 communities, and the density of animals was about 100 000 individuals m^{-2} in both the furoid and seagrass beds (Fredriksen et al. 2005). The differences in species composition are evidenced by the dominance of the gastropod *Rissoa parva* on *F. serratus* and *R. membranacea* (J. Adams) on *Z. marina*, while the closely related Ischyroceridean amphipods *Jassa falcata* (Montagu) and *Erichthonius difformis* (Milne Edwards) were similarly almost exclusively found at high abundances on *F. serratus* and *Z. marina*, respectively (see Fredriksen et al. 2005).

The data presented in Figs. 2 to 5 indicate that structural diversity is of great importance for the diversity of associated faunal species. In addition, Figs. 3 & 4 illustrate differences in the vertical distribution of fauna on upright habitats; there are different faunal compositions from the canopy layer downwards to the substratum level (see also Christie et al. 2003, 2007). This may be due to differences in macrophyte structure and longevity of the habitat and also other factors (see 'Faunal mobility').

The number of faunal species found in the samples of 3 or 4 replicate *Laminaria hyperborea* kelps varied between 90 and 132, while average number of species found on single kelps was about 80 to 90. By including fauna on 56 kelps (*L. hyperborea*), Christie et al. (2003)

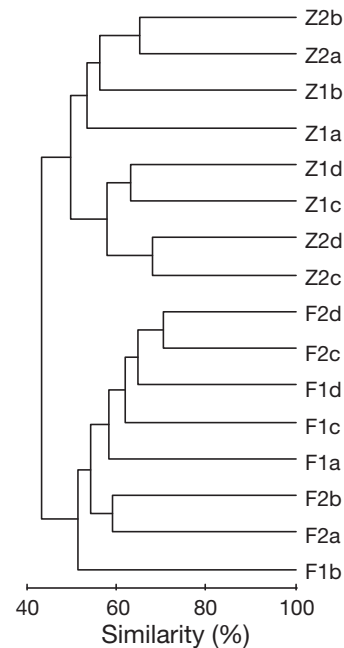

Fig. 5. Dendrogram comparing faunal composition in *Zostera marina* (Z) and *Fucus serratus* (F) at 3 m depth growing close to each other at 2 sites (1 and 2). Samples from April, June, September and November are indicated by a, b, c and d, respectively. Data from Fredriksen & Christie (2003)

identified a total of 238 species. The most abundant and species-rich faunal group was amphipods, with 60 species, while 48 species were identified in the second most abundant group, gastropods. In all macrophytes, amphipods and other crustaceans, gastropods, bivalves and polychaetes dominated most samples, both in number of species and abundance (Christie et al. 2003, 2007, Fredriksen et al. 2005, present study; Table 1). Most of the animal species were small, typically <10 mm. Although abundances varied with habitat size, the number of associated faunal species did not. However, species number was higher in the large and more complex macrophytes such as kelps than in the smaller turf algae (Table 1).

The number of species of associated fauna was found to depend on habitat architecture (complexity) as described above. The large number of faunal species on less complex habitats such as *Zostera marina* and *Fucus serratus* (Table 1, see Fredriksen et al. 2005) may be due to factors that increase the habitat complexity. Fredriksen et al. (2005) found more than 100 species of small epiphytic algae on *Z. marina* and *F. serratus*; these algae contribute to the habitat volume and complexity and thereby to higher diversity of associated fauna. Some of the variation in faunal composition within the same macrophyte species (Table 1) is probably due to differences in epiphytic load.

Macrophytes as habitat and food

Macrophytes in the present study were mainly used by fauna as habitat and were not grazed. As primary producers, macrophytes are among the most productive on the planet (Lüning 1990, Mann 2000, Barrón et al. 2003, Abdullah & Fredriksen 2004) and may thus be expected to be important as a food resource to associated fauna. A food chain from macrophytes via invertebrates to fish has been identified (Norderhaug et al. 2003, Fredriksen 2003, Norderhaug et al. 2005); however, the macrophyte carbon is not grazed directly, probably due to a high C:N ratio in the summer (Norderhaug et al. 2003). Consequently, carbon is released as dissolved organic matter (DOM) or particulate organic matter (POM), degraded (and enriched) by microorganisms and then made available as food to animals. This is shown by Norderhaug et al. (2003) for POM, where common kelp faunal species did not survive or grow when fed fresh kelp, but only when fed kelp degraded (or enriched) by microorganisms. Further, Norderhaug (2004) showed that kelp-associated amphipods selected habitat (red algal species) according to architectural structure and complexity and not according to food value, indicating that the habitat was mainly important for protection and not as a food source (see also Paul et al. 2001). Normally, as the macrophytes are not grazed, but rather support the fauna with food after being released as POM or DOM and degraded, the macrophytes are prevented from being overgrazed by their inhabitants. Kelp and other macroalgae release a high percentage of their carbon production as DOM (Barrón et al. 2003, Abdullah & Fredriksen 2004), and a proportion of this may form the mucus layer on algal surfaces that has been found to attract microorganisms (Gismervik 2004). This may be a nutrient source for, in particular, gastropods that are observed feeding on these surfaces; however, this must be further investigated.

Field data support the results discussed above. POM sampled in sediment traps in dense kelp forest showed a stable isotope ratio in the same range as kelp (–16 to –18‰, Fredriksen 2003). The POM C:N ratio from sediment traps was lower than in kelp, indicating a higher nutritional value. Stomach analysis from kelp forest fish revealed that these fish species mainly fed on kelp fauna (Norderhaug et al. 2005) and stable isotope analysis also showed kelp-derived carbon to be important (Fredriksen 2003). The kelps are thus the primary producer supplying the kelp forest ecosystem with carbon, but the kelps are mainly eaten by mesograzers as degraded (or N-enriched) POM or DOM rather than being grazed.

The mesograzers feeding on macrophyte surfaces remove smaller epiphytes like diatoms and foliose algae, and are thus important for keeping the larger

macrophytes free from being overgrown by epiphytic competitors (Moksnes et al. 2008). However, in some cases the grazers increase in density to an extent that they start to overgraze the macrophytes which are then grazed to extinction. This has been observed for kelp, although they are not preferred as food (see Christie & Rueness 1998). The most extensive event in Norwegian waters is the grazing of kelp by sea urchins, resulting in a marine desert along almost half the coastline (Sivertsen 1997). Smaller grazers (mesograzers) like the gastropod *Rissoa membranacea*, which is common on seagrass in southern Norway, have also been found to graze down seagrass beds when occurring in high densities (Fredriksen et al. 2004). Grazer densities seem to be regulated by fish predation in healthy macrophyte systems (Moksnes et al. 2008), and by dispersal out of the system (Jørgensen & Christie 2003, Christie & Kraufvelin 2004). Thus, the macrophytes may become vulnerable if grazers occur in too high numbers; for example, disappearance of regulatory processes by overfishing of top predators has been suggested as a reason for blooms of sea urchins, leading to overgrazing and decimation of kelp beds (Steneck et al. 2004).

Faunal mobility

High faunal mobility ensures rapid colonization and utilization of available habitats. The most abundant faunal components associated with macrophytes are highly mobile. They move frequently between plants (Norderhaug et al. 2002) and there is high dispersal out of macrophyte beds (Jørgensen & Christie 2003, Waage-Nielsen et al. 2003, Christie & Kraufvelin 2004). Mobility and dispersal patterns have emerged by exposing artificial substrates for study of colonization over short periods (hours to weeks). Fig. 6 shows numbers of kelp fauna collected on substrates exposed within the kelp forest and at different distances into sandy bottom habitat over 4 d. Waage-Nielsen et al. (2003) found rapid and abundant dispersal of kelp fauna to areas with no kelp. Most species dispersed rapidly and were found in high densities on artificial substrates inside and at different distances outside the kelp forest. High dispersal or export of mobile fauna from furoid communities has also been documented in controlled mesocosm studies (Christie & Kraufvelin 2004). Between 1 and 2% of the amphipod and isopod populations were lost from the mesocosms daily, while the populations and abundances still persisted throughout years (no dispersal into the mesocosms was observed).

There are, however, differences in the mobility of faunal species, and based on data comparing occur-

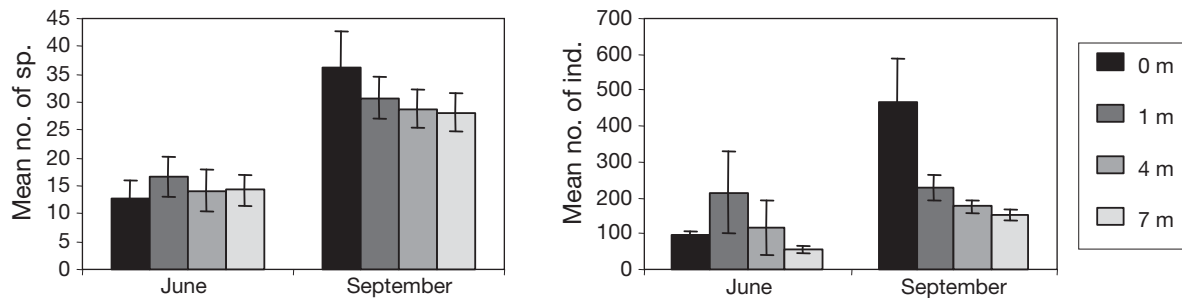

Fig. 6. Colonisation by kelp fauna of artificial substrate exposed for 4 d inside a kelp forest (0 m) and at different distances (1, 4 and 7 m) from the kelp on a sandy bottom in June and September, presented as mean number of species and mean number of individuals per artificial substrate. Error bars are SE. Data from Jørgensen & Christie (2003)

rences in natural habitats and artificial substrates exposed for short time periods (Norderhaug et al. 2002, Waage-Nielsen et al. 2003), the relative mobility of the different species groups was estimated. Amphipods and some other crustaceans had high relative mobility, as well as gastropods (by drifting, Vahl 1983, Christie et al. 2007). Other abundant faunal groups associated with macrophytes, such as polychaetes and bivalves, had lower relative mobilities. In the kelp forest, Norderhaug et al. (2002) found lower mobility among animals living in kelp holdfasts than animals living on epiphytes on the stipes. A high dispersal rate, even among gastropods and bivalves that are regarded as slow or sedentary, is most likely an adaptation to life associated with ephemeral habitats. As laminas and many epiphytic algae are annuals or of even shorter seasonal duration, animals need to move between available habitats to a greater extent than those living in the holdfast, which has a lifetime of 10 yr or more. While high mobility increases the ability to colonise habitats, it is also expected to be disadvantageous by increasing the exposure to predators like fish, and increasing the risk of being transported out of the macrophyte bed. Jørgensen & Christie (2003) found higher dispersal at night than during the day, probably to avoid visual predators like fish. High dispersal rates may also be a result of space limitation. Manipulations where artificial habitats of different sizes were anchored to kelp stipes showed correlations between faunal abundance and habitat size (see Fig. 1). Winder (1990) suggested that habitats can support more animals if the animals are in regular movement. Hence, the above mentioned studies indicate that space is limited.

Disturbances and macrophyte persistence

Disturbances in macrophyte systems may have great implications for the abundance and species composition of the associated fauna (see Table 1, Fig. 2). A

number of disturbances, including anthropogenic activities, negatively affect macrophyte systems and in some cases bring the systems out of equilibrium (Steenek & Carlton 2001). This may lead to a phase shift and a new stable state, but in other situations, stabilising mechanisms bring the system back towards its origin. Data from several studies have demonstrated both cases.

Storm events and kelp harvesting (kelp trawling, see Christie et al. 1998) are disturbances that have limited effect due to the high resilience of the kelp forest. Both storms (large wave actions) and kelp trawls remove the adult canopy plants, but an understory of kelp recruits respond to the removal of the canopy by increasing their growth rate, ensuring that kelp outcompetes other macrophytes (Christie et al. 1998). Kelp can grow to full canopy size in a few years, and harvesting in Norwegian waters is, depending on latitude, allowed every 4 or 5 yr. However, the kelp forest ecosystem has not fully recovered after 5 yr and, although the mobile fauna have potential for quick recolonization to the new kelp, the stipe epiphytes and thus important habitats do not recover fully for 5 to 7 yr.

In Norwegian waters, overgrazing by the sea urchin *Strongylocentrotus droebachiensis* O.F. Müller has been the most extensive threat to macrophyte beds (Sivertsen 1997). A sea urchin bloom some 40 yr ago resulted in destructive grazing of large areas of kelp forests (see Sivertsen 1997, Norderhaug & Christie 2009). The kelp forest system flipped to a new stable state (barren ground) that has persisted since then. The barren state will persist as long as the sea urchins can maintain their high population densities (see Norderhaug & Christie 2009). A decrease in sea urchin abundance will lead to reestablishment of the kelp forest (Christie et al. 1995, Leinaas & Christie 1996, Norderhaug & Christie 2009). While the kelp forest is a habitat for a rich fauna (see Table 1), the barren ground is almost totally depleted of all plants and animals (except sea urchins), and a comparison of production has shown a difference of 2 orders of magnitude

(Chapman 1981). We have performed similar studies of mobile fauna in kelp beds and on barren grounds by use of short-term artificial substrates. In kelp beds and adjacent to kelp beds, standardised rope bundles were colonized by an average of about 40 species and 500 individuals within 4 d (Fig. 6, see also Norderhaug et al. 2002, Waage-Nielsen et al. 2003) and during one night only, Jørgensen & Christie (2003) found an average of 21 species (SE = 0.8) and 178 (5.4) individuals dominated by amphipods and gastropods. In the large barren ground area in the Porsanger fjord, the average colonization to 15 rope bundles exposed for 1 d was only 4.7 (0.5) species and 52 (8.6) individuals (present study, August 2006). A majority of the colonizing animals were juvenile mussels and amphipods, probably dispersed from fucoids in the intertidal zone. This confirms the low faunal diversity and abundance in barren areas.

Shifts caused by eutrophication have been reported in a number of shallow benthic systems, where canopy-forming perennial macroalgae and seagrasses have been replaced by ephemeral filamentous algae (e.g. Duarte 1995, Schramm 1996, Valiela et al. 1997, Worm & Lotze 2006, Burkholder et al. 2007). Although these communities may be resistant to disturbances such as eutrophication, Bokn et al. (2003) reported no large effects on fucoid communities of nutrient additions during a 3-yr experimental mesocosm study. By prolonging the experiment performed by Bokn et al. (2003) for another 2 yr, Kraufvelin et al. (2006b) detected a sudden and dramatic shift from perennials to ephemerals (mainly *Ulva* spp.) in eutrophicated mesocosms, while the perennial communities persisted in the control mesocosms. After ending the experiment and terminating nutrient additions, the affected communities recovered within 1 to 2 yr. This shows that the system can be robust for a long period, showing no response to disturbance, but once a threshold is reached the community may flip to another state (delayed effects), and also show high resilience when the disturbance decreases. There may be similar mechanisms behind the dramatic *Saccharina latissima* decline in southern Norway, where large areas formerly covered by *S. latissima* have been replaced by turf algae communities (Moy et al. 2008). Synergetic effects including global warming, overfishing and eutrophication may be driving forces for this phase shift (Worm & Lotze 2006, Jackson 2008). On the Swedish Skagerrak coast, Moksnes et al. (2008) found that reduced grazing by mesograzers on ephemeral algae increased the effects of eutrophication in seagrass beds. Cascading effects caused by overfishing of larger predatory fish resulted in increased stocks of small fish, reduced mesograzers populations (and activity) and increased growth of ephemeral algae. So far

this has not been investigated on the Norwegian Skagerrak coast, but some data indicate a similar pattern (Moy et al. 2008). Coastal fish stocks including coastal cod stocks have been reduced (cod is on the Norwegian 'Red list'), and there has been a reduction in mesograzers abundance when macrophyte beds shift from perennial- to turf algae-dominated communities (Table 1).

CONCLUSIONS

Macrophyte habitats are highly productive systems which comprise rich associated faunal communities. They cover large areas of the Norwegian coast and provide habitat for macrofaunal communities, which typically exceed densities of 100 000 individuals m⁻². Habitat size was the most important factor in determining animal abundances, and small-scale structural complexity was the most important factor for the faunal diversity and composition; this trend was consistent over large areas. The macrofauna associated with macrophytes were generally highly mobile, and fauna associated with perennial habitats were typically less mobile than fauna associated with habitats of shorter duration. The species found in the kelp holdfasts, with longevity of 10 yr and more, are less mobile than species living on seasonal algae (Norderhaug et al. 2002).

High mobility increases exposure to visual predators such as fish and increases dispersal (loss) out of the system, but it may still be advantageous for macrophyte-associated animals. High mobility increases the ability to utilize available habitat. Sampling and manipulations in macrophyte systems indicated that space (and not food) is limited for the mobile macrofauna, and high mobility may be an advantage where this resource is limited (Winder 1990, Norderhaug et al. 2002, 2007, Christie & Kraufvelin 2004). Grazer control, as a factor contributing to the prevention of overgrazing, may be important for the persistence of the system.

A food chain structure has been found, where macrophyte POM—the kelp is not suitable food before it has been released as POM and degraded by bacteria (Norderhaug et al. 2003)—is used by invertebrates, which in turn are eaten by fish (Fredriksen 2003, Norderhaug et al. 2005) and also lost from the system by export. Habitat availability seems important in regulating mesograzers abundances. The result is an ecosystem with high persistence where the invertebrates are prevented from overgrazing their habitat. If the grazer control for some reason is removed, grazer populations may increase and overgrazing may occur.

Thus, the macrophyte system seems to be persistent due to a balance of regulatory mechanisms between

primary producers, grazers and/or herbivores and predators. The diversity of macrophyte species in terms of architecture (structural complexity) is, according to the data presented here, important for the diversity of associated invertebrates. The diversity of the macrophytes seems to be dependent on a balanced distribution and grazing activity among the grazers, which prefer different macrophytes (Duffy et al. 2001, 2003). A high functional redundancy will further increase the stability of the macrophyte system. If the grazer populations decline then the perennial macrophytes may be overgrown by filamentous algae (see Moksnes et al. 2008), resulting in decreasing diversity of algae and animals (Table 1). The last example has been described as a cascade (top-down) effect caused by overfishing of predatory fish and enhanced by other (synergetic) factors (see Jackson et al. 2001, Jackson 2008).

A growing awareness of the importance of macrophyte beds as habitats and producers for species-rich and abundant fauna has increased the focus on these systems. They are now regarded as an important part of the coastal ecosystem by nature and resource management authorities in Norway. As the persistence, resilience and vulnerability of these systems are dependent on interactions between large macrophytes, smaller epiphytes, grazers and animals higher up in the food web, knowledge of ecosystem structure and function is necessary for decision-making regarding kelp trawling-, fishery- and eutrophication-related management. Future research should, in particular, focus on the possible effects of overfishing in coastal areas.

LITERATURE CITED

- Abdullah MI, Fredriksen S (2004) Production, respiration and exudation of dissolved organic matter by the kelp *Laminaria hyperborea* along the west coast of Norway. *J Mar Biol Assoc UK* 84:887–894
- Baden SP, Boström C (2000) The leaf canopy of seagrass beds: faunal community structure and function in a salinity gradient along the Swedish coast. In: Reise K (ed) *Ecological comparisons of sedimentary shores*. Ecological Studies 151, Springer-Verlag, Berlin, p 213–236
- Baden SP, Phil L (1984) Abundance, biomass and production of mobile fauna in *Zostera marina* (L.) meadows, western Sweden. *Ophelia* 23:65–90
- Barrón C, Marbà N, Duarte CM, Pedersen MF and others (2003) High organic carbon export precludes eutrophication responses in experimental rocky shore communities. *Ecosystems* 6:144–153
- Bokn TL, Duarte CM, Pedersen MF, Marbà N and others (2003) The response of experimental rocky shore communities to nutrient additions. *Ecosystems* 6:577–594
- Bray JR, Curtis JT (1957) An ordination of the upland forest communities of southern Wisconsin. *Ecol Monogr* 27: 325–349
- Burkholder JA, Tomasko DA, Touchette BW (2007) Seagrasses and eutrophication. *J Exp Mar Biol Ecol* 350:46–72
- Chapman ARO (1981) Stability of sea urchin dominated barren grounds following destructive grazing of kelps in St. Margaret's Bay, eastern Canada. *Mar Biol* 62:307–311
- Christie H, Kraufvelin P (2004) Mechanisms regulating amphipod population density within macroalgal communities with restricted predator impact. *Sci Mar* 68:189–198
- Christie H, Rueness J (1998) Tareskog (kelp forests). In: Rinde E, Bjørge A, Eggereide A, Tuffeland G (eds) *Kystøkologi, den ressursrike norskekysten*. Universitetsforlaget, Oslo, p 164–189
- Christie H, Leinaas HP, Skadsheim A (1995) Local patterns in mortality of the green sea urchin, *Strongylocentrotus droebachiensis*, at the Norwegian coast. In: Skjoldal HR, Hopkins C, Erikstad KE, Leinaas HP (eds) *Ecology of fjords and coastal waters*. Elsevier, Amsterdam, p 573–584
- Christie H, Fredriksen S, Rinde E (1998) Regrowth of kelp and colonization of epiphyte and fauna community after kelp trawling at the coast of Norway. *Hydrobiologia* 375–376:49–58
- Christie H, Jørgensen NM, Norderhaug KM, Waage-Nielsen E (2003) Species distribution and habitat exploitation of fauna associated with kelp (*Laminaria hyperborea*) along the Norwegian coast. *J Mar Biol Assoc UK* 83:687–699
- Christie H, Jørgensen NM, Norderhaug KM (2007) Bushy or smooth, high or low; importance of habitat architecture and vertical position for distribution of fauna on kelp. *J Sea Res* 58:198–208
- Clarke KR (1993) Non-parametric multivariate analyses of changes in community structure. *Aust J Ecol* 18:117–143
- Colman J (1940) On the faunas inhabiting intertidal seaweeds. *J Mar Biol Assoc UK* 24:129–183
- Dommasnes A (1969) On the fauna of *Corallina officinalis* L. in western Norway. *Sarsia* 38:71–86
- Duarte CM (1995) Submerged aquatic vegetation in relation to different nutrient regimes. *Ophelia* 41:87–112
- Duffy JE, Macdonald KS, Rhode JM, Parker JD (2001) Grazer diversity, functional redundancy, and productivity in seagrass beds: an experimental test. *Ecology* 82:2417–2434
- Duffy JE, Richardson JP, Canuel EA (2003) Grazer diversity effects on ecosystem functioning in seagrass beds. *Ecol Lett* 6:637–645
- Edgar GJ (1990) The influence of plant structure on the species richness, biomass and secondary production of macrofaunal assemblages associated with Western Australian seagrass beds. *J Exp Mar Biol Ecol* 137:215–240
- Edgar GJ (1991) Artificial algae as habitats for mobile epifauna: factors affecting colonization in a Japanese *Sargassum* bed. *Hydrobiologia* 226:111–118
- Edwards A (1980) Ecological studies of the kelp, *Laminaria hyperborea*, and its associated fauna in south-west Ireland. *Ophelia* 19:47–60
- Elner RW, Vadas RL Sr (1990) Inference in ecology: the sea urchin phenomenon in the Northwestern Atlantic. *Am Nat* 136:108–125
- Fenwick GD (1976) The effect of wave exposure on the amphipod fauna of the algae *Caulerpa brownii*. *J Exp Mar Biol Ecol* 25:1–18
- Fredriksen S (2003) Food web studies in a Norwegian kelp forest based on stable isotope ($\delta^{13}\text{C}$ and $\delta^{15}\text{N}$) analysis. *Mar Ecol Prog Ser* 260:71–81
- Fredriksen S, Christie H (2003) *Zostera marina* (Angiospermae) and *Fucus serratus* (Phaeophyceae) as habitat for flora and fauna: seasonal and local variation. In: Chapman ARO, Anderson RJ, Vreeland VJ, Davison IR (eds) *Proc 17th Int Seaweed Symp, Cape Town, 28 Jan–2 Feb 2001*. Oxford University Press, Oxford, p 357–364

- Fredriksen S, Christie H, Bostrom C (2004) Deterioration of eelgrass (*Zostera marina* L.) through destructive grazing by the gastropod *Rissoa membranacea* (J. Adams). *Sarsia* 89:218–222
- Fredriksen S, Christie H, Sætre BA (2005) Species richness in macroalgae and macrofauna assemblages on *Fucus serratus* L. (Phaeophyceae) and *Zostera marina* L. (Angiospermae) in Skagerrak, Norway. *Mar Biol Res* 1:2–19
- Gismervik I (2004) Podite carrying ciliates dominate the benthic ciliate community in the kelp forest. *Aquat Microb Ecol* 36:305–310
- Hacker SD, Steneck RS (1990) Habitat architecture and the abundance and body-size-dependent habitat selection of a phytal amphipod. *Ecology* 71:2269–2285
- Hagerman L (1966) The macro and microfauna associated with *Fucus serratus* L. with some ecological remarks. *Ophelia* 3:1–43
- Jackson JBC (2008) Ecological extinction and evolution in the brave new ocean. *Proc Natl Acad Sci USA* 105:11458–11465
- Jackson JBC, Kirby MX, Berger WH, Bjorndal KA and others (2001) Historical overfishing and the recent collapse of coastal ecosystems. *Science* 293:629–638
- Jones DJ (1971) Ecological studies on macroinvertebrate populations associated with polluted kelp forests in the North Sea. *Helgol Wiss Meeresunters* 22:417–441
- Jorde I (1966) Algal associations of a coastal area south of Bergen, Norway. *Sarsia* 23:1–52
- Jørgensen NM, Christie H (2003) Diurnal, horizontal and vertical dispersal of kelp-associated fauna. *Hydrobiologia* 503:69–76
- Kraufvelin P, Christie H, Olsen M (2002) Macrofauna (secondary) responses to experimental nutrient addition to rocky shore mesocosms and a coastal lagoon. *Hydrobiologia* 484:149–166
- Kraufvelin P, Salovius S, Christie H, Moy FE, Karez R, Pedersen MF (2006a) Eutrophication-induced changes in benthic algae affect the behaviour and fitness of the marine amphipod *Gammarus locusta*. *Aquat Bot* 84:199–209
- Kraufvelin P, Moy FE, Christie H, Bokn TL (2006b) Nutrient addition to experimental rocky shore communities revisited: delayed responses, rapid recovery. *Ecosystems* 9:1076–1093
- Kruskal JB (1964a) Multidimensional scaling by optimizing goodness-of-fit to a nonmetric hypothesis. *Psychometrika* 29:1–28
- Kruskal JB (1964b) Nonmetric multidimensional scaling: a numerical method. *Psychometrika* 29:115–129
- Lawrence JM (1975) On the relationship between marine plants and sea urchins. *Oceanogr Mar Biol Annu Rev* 13:213–286
- Leinaas HP, Christie H (1996) Effects of removing sea urchins (*Strongylocentrotus droebachiensis*): stability of the barren state and succession of kelp forest recovery in the east atlantic. *Oecologia* 105:524–536
- Lüning K (1990) Seaweeds: their environment, biogeography, and ecophysiology. John Wiley & Sons, New York
- Mann KH (2000) Ecology of coastal waters: with implications for management. 2nd edition. Blackwell Science, Malden, MA
- Marstein AC (1997) Epiphytic algae on kelp stipes from Vega—an area with varying densities of sea urchins. *Blyttia* 55:123–129 (In Norwegian with English Abstract)
- Martin-Smith KM (1993) Abundance of mobile epifauna: the role of habitat complexity and predation by fishes. *J Exp Mar Biol Ecol* 174:243–260
- Moksnes PO, Gullstrom M, Tryman K, Baden S (2008) Trophic cascades in a temperate seagrass community. *Oikos* 117:763–777
- Moore PG (1973) The kelp fauna of northeast Britain. II. Multivariate classification: turbidity as an ecological factor. *J Exp Mar Biol Ecol* 13:127–163
- Moore PG (1986) Levels of heterogeneity and the amphipod fauna of kelp holdfasts. In: Moore PG, Seed R (eds) *The ecology of rocky coasts*. Columbia University Press, New York, p 274–290
- Moy F, Christie H, Steen H, Stålnacke P and others (2008) Final report from the sugar kelp project. SFT-rapport TA-2467/2008, NIVA-rapport 5709, NIVA, Oslo (in Norwegian)
- Nelson WG (1980) A comparative study of amphipods in seagrasses from Florida to Nova Scotia. *Bull Mar Sci* 30:80–89
- Norderhaug KM (2004) Use of red algae as hosts by kelp-associated amphipods. *Mar Biol* 144:225–230
- Norderhaug KM, Christie H (in press) Sea urchin grazing and kelp re-vegetation in the NE Atlantic. *Mar Biol Res*
- Norderhaug KM, Christie H, Rinde E (2002) Colonisation of kelp imitations by epiphyte and holdfast fauna; a study of mobility patterns. *Mar Biol* 141:965–973
- Norderhaug KM, Fredriksen S, Nygaard K (2003) Trophic importance of *Laminaria hyperborea* to kelp forest consumers and the importance of bacterial degradation to food quality. *Mar Ecol Prog Ser* 255:135–144
- Norderhaug KM, Christie H, Fosså JH, Fredriksen S (2005) Fish–macrofauna interactions in a kelp (*Laminaria hyperborea*) forest. *J Mar Biol Assoc UK* 85:1279–1286
- Norderhaug KM, Christie H, Fredriksen S (2007) Space limitation in a Norwegian kelp *Laminaria hyperborea* forest? Evidence from using artificial habitats. *J Sea Res* 58:120–124
- Paul VJ, Cruz-Rivera E, Thacker RW (2001) Chemical mediation of macroalgal–herbivore interactions: ecological and evolutionary perspectives. In: McClintock JB, Baker BJ (eds) *Marine chemical ecology*. CRC Press, Boca Raton, FL, p 227–265
- Pinnerup SP (1980) Leaf production of *Zostera marina* L. at different salinities. *Ophelia Suppl* 1:219–224
- Schramm W (1996) The Baltic Sea and its transition zones. In: Schramm W, Nienhuis PH (eds) *Marine benthic vegetation. Recent changes and effects of eutrophication*. Springer, Heidelberg, p 131–163
- Schultze K, Janke K, Krüß A, Weidemann W (1990) The macrofauna and macroflora associated with *Laminaria digitata* and *L. hyperborea* at the island of Helgoland (German Bight, North Sea). *Helgol Mar Res* 44:39–51
- Shepard RN (1962) The analysis of proximities: multidimensional scaling with an unknown distance function. II. *Psychometrika* 27:219–246
- Sivertsen K (1997) Geographical and environmental factors affecting the distribution of kelp beds and barren grounds and changes in biota associated with kelp reduction at sites along the Norwegian coast. *Can J Fish Aquat Sci* 54:2872–2887
- Sjötun K, Fredriksen S, Rueness J, Lein TE (1995) Ecological studies of the kelp *Laminaria hyperborea* (Gunnerus) Foslie in Norway. In: Skjoldal HR, Hopkins C, Erikstad KE, Leinaas HP (eds) *Ecology of fjords and coastal waters*. Elsevier, Amsterdam, p 525–536.
- Steneck RS, Carlton JT (2001) Human alterations of marine communities: Students beware. In: Bertness MD, Gaines SD, Hay ME (eds) *Marine community ecology*. Sinauer Associates, Sunderland, MA, p 445–468
- Steneck RS, Graham MH, Bourque BJ, Corbett D, Erlandson JM, Estes JA, Tegner MJ (2002) Kelp forest ecosystems:

- biodiversity, stability, resilience and future. *Environ Conserv* 29:436–459
- Steneck RS, Vavrinc J, Leland AV (2004) Accelerating trophic-level dysfunction in kelp forest ecosystems of the Western North Atlantic. *Ecosystems* 7:323–332
- Vahl O (1983) Mucus drifting in the limpet *Helcion (=Patina) pellucida* (Prosobranchia, Patellidae). *Sarsia* 68:209–211
- Valiela I, McClelland J, Hauxwell J, Behr PJ, Hersh D, Foreman K (1997) Macroalgal blooms in shallow estuaries: controls and ecophysiological and ecosystem consequences. *Limnol Oceanogr* 42:1105–1111
- Waage-Nielsen E, Christie H, Rinde E (2003) Short term dispersal of kelp fauna to cleared (kelp harvested) areas. *Hydrobiologia* 503:77–91
- Winder L (1990) Predation of cereal aphid *Sitobion avenae* by polyphagous predators on the ground. *Ecol Entomol* 15:105–110
- Worm B, Lotze HK (2006) Effects of eutrophication, grazing, and algal blooms on rocky shores. *Limnol Oceanogr* 51:569–579

Submitted: May 6, 2009; Accepted: September 30, 2009

Proofs received from author(s): November 27, 2009



Intertidal molluscan and algal species richness around the UK coast

Andrew J. Blight^{1,*}, A. Louise Allcock^{1,2}, Christine A. Maggs^{1,2}, Mark P. Johnson^{1,2}

¹School of Biological Sciences, Queen's University Belfast, Medical Biology Centre, 97 Lisburn Road, Belfast, BT9 7BL, UK

²The Martin Ryan Marine Science Institute, National University of Ireland, University Road, Galway, Ireland

ABSTRACT: Geographically referenced databases of species records are becoming increasingly available. Doubts over the heterogeneous quality of the underlying data may restrict analyses of such collated databases. We partitioned the spatial variation in species richness of littoral algae and molluscs from the UK National Biodiversity Network database into a smoothed mesoscale component and a local component. Trend surface analysis (TSA) was used to define the mesoscale patterns of species richness, leaving a local residual component that lacked spatial autocorrelation. The analysis was based on 10 km grid squares with 115 035 records of littoral algae (729 species) and 66 879 records of littoral molluscs (569 species). The TSA identified variation in algal and molluscan species richness with a characteristic length scale of approximately 120 km. Locations of the most species-rich grid squares were consistent with the southern and western bias of species richness in the UK marine flora and fauna. The TSA also identified areas which showed significant changes in the spatial pattern of species richness: breakpoints, which correspond to major headlands along the south coast of England. Patterns of algal and molluscan species richness were broadly congruent. Residual variability was strongly influenced by proxies of collection effort, but local environmental variables including length of the coastline and variability in wave exposure were also important. Relative to the underlying trend, local species richness hotspots occurred on all coasts. While there is some justification for scepticism in analyses of heterogeneous datasets, our results indicate that the analysis of collated datasets can be informative.

KEY WORDS: Hotspot · Headland · Trend surface analysis · Mesoscale · Autocorrelation · Local · Regional

Resale or republication not permitted without written consent of the publisher

INTRODUCTION

While broad latitudinal gradients have traditionally been a focus of biodiversity research, there are also mesoscale patterns of variation in species richness that are less well characterized (10^1 to 10^6 km²; Harrison & Cornell 2008). Such mesoscale patterns are important, as they interact with the typical dispersal scales of marine organisms (median 20 km, interquartile range 1 to 106 km; Kinlan & Gaines 2003) and the spacing of protected areas (median 21 km nearest neighbour distance, interquartile range 13 to 37 km; Johnson et al. 2008). Examples of variability in species richness include areas of high (or low) species richness, the variation be-

ing associated with features such as large estuaries and abrupt changes or 'breakpoints' in species richness. For the UK, a variety of regional features have been proposed (e.g. Crisp & Southward 1958, Lewis 1964, Briggs 1974, Lüning 1990). With the recent development of biodiversity data servers (e.g. the National Biodiversity Network [NBN] Gateway, <http://data.nbn.org.uk/>) it is now possible to revisit earlier work and examine the spatial patterns in a statistical model-fitting framework. Spatially explicit analyses of this sort are an important component of sustainability planning in marine spatial management programmes (Ehler & Douvere 2009).

Patterns of species diversity typically vary at multiple scales, reflecting the different processes involved

*Email: ablight01@qub.ac.uk

(Levin 1992, Willis & Whittaker 2002). Ideally one could separate out the components at different scales to gain a greater understanding of pattern. Unfortunately, 2 issues limit this approach: (1) processes at different scales are unlikely to be completely independent and cross-scale interactions occur (e.g. Gouhier & Guichard 2007); (2) methods such as spectral and wavelet analysis can be used to examine patterns at different scales, but each method has limitations (Saunders et al. 2005). In the context of species richness values along a coastline, the data are not in a regular unbroken sequence and are therefore unsuited to wavelet or spectral analyses. A practical solution to the multiscale nature of species diversity is to examine the patterns at a limited number of discrete scales. This approach is often associated with nested studies, where the allocation of effort can be standardized (Rivadeneira et al. 2002). A typical contrast has been one between regional and local diversity (Ricklefs 1987). In the present study, we made the same contrast, but the relationship between local and regional is defined using a regression-based smoother rather than by pooling samples. For consistency, we refer to the larger scale variation estimated by the regression-based smoother as regional or mesoscale variability. Local variation then refers to the pattern of residual variation at the 10 km grid scale. Regression-based smoothing avoids the correlation between local and regional richness that confounds many studies (Hillebrand & Blenckner 2002).

Data quality potentially influences the perceived spatial variation of biodiversity in datasets collated over many surveys. Survey effort varies due to the number of visits to particular areas, among other possible sources of variation such as the identification skills of observers. Our initial observations of the spatial patterns in untransformed species richness show peaks in the data that correspond to the major marine research stations around the UK. As abundance information and details of methodology were frequently absent in the collated dataset, it was not possible to attempt a correction for effort with a rarefaction procedure. The approach taken in the present study was not to correct the data prior to exploration, but to test for associations with proxies of collection effort following model fitting. We anticipated that variation in collection effort is a relatively local-scale process so that this variation will affect the residual pattern more strongly than the smoothed species richness. To test this idea we compared the spatial autocorrelation functions of smoothed data and collection effort, with a prediction that the spatial extent of autocorrelation will be greater in the smoothed data. We also predicted that variation in collection effort will have a significant effect on residual species richness. Other variables are likely to

influence local species richness, including mean wave exposure, length of coastline and variance in wave exposure. Associations between species richness and these additional predictor variables were examined in exploratory regression analyses.

In summary, the present study examined the spatial patterns in species richness of intertidal algae and molluscs around the coast of the UK. The spatial variation in species richness was partitioned, using a spatial smoothing function, into a mesoscale component and a residual component. In addition to a description of the mesoscale pattern, we present an identification of the sharpest transitions in species richness between grid squares. The residual components of species richness were compared to proxies of collection effort and other abiotic influences to identify sources of variation in recorded local species richness.

METHODS

Database construction. The NBN Gateway was accessed to retrieve data on UK marine surveys from a variety of sources. These sources included the Marine Nature Conservation Review (MNCR) dataset compiled by the Joint Nature Conservation Committee (JNCC), Countryside Council for Wales (CCW) and Scottish National Heritage (SNH); the British Phyco-logical Society (BPS) dataset; the Conchological Society of Great Britain and Ireland (ConchSoc) dataset; the Marine Life Information Network (MarLIN) dataset (both professional and volunteer); the Northern Ireland Littoral Survey (NILS) dataset; the Marine Conservation Society (MCS) Seasearch Marine Surveys and the Pembrokeshire Tide Influenced Communities dataset. The records were accessed and collated between March and May 2006 and periodically updated throughout 2007. These data included species richness (presence/absence) at a resolution of 10×10 km grid squares. Each grid square had a geographic coordinate based on its position in the Ordnance Survey (OSGB) grid system. Analyses were focused on patterns for littoral molluscs and algae, as these are the 2 most widely recorded groups and molluscs have been shown to act as surrogates for broader patterns in littoral assemblages (Smith 2005).

The NBN data included both littoral and sublittoral records and were filtered to produce littoral-only fauna and flora. Where information on record shore height was missing, site records were allocated to an appropriate level through a comparison of the list of species at that site against a list of known littoral/sublittoral species. These test species were drawn from complete records, provided they were found in their corresponding zone on more than 99% of occasions and had at

least 50 records in the database. All subsequent statistical analysis was carried out on littoral species richness data.

Spatial analysis of pattern. The subdivision of species richness patterns into a regional and local component was carried out using trend surface analysis (TSA). This is the oldest technique applied for producing smoothed maps (Legendre & Legendre 1998) and involves fitting a polynomial equation based on the geographic coordinates to the dependent variable (species richness in a 10×10 km grid square). Non-significant terms are removed from the polynomial by backwards elimination to produce the most parsimonious model (Legendre & Legendre 1998). The smoothing process emphasizes spatial gradients in richness and can be thought of as the regional signal. As the model-fitting process is not constrained by a particular expectation, the resultant regional pattern could be a latitudinal gradient or a more complex set of features. As well as a visual examination of the pattern in the smoother, the typical length scale of richness patterns in the intertidal was estimated using spatial autocorrelation. The smoother is anticipated to be less sensitive to changes in species richness that are related to local collection effort, so relatively abrupt changes in the predicted species richness were used to define the positions of breakpoints (sudden transitions in species richness). The mean change in species richness between adjacent squares was 2.28 for molluscs and 3.33 for algae. Transitions greater than the mean + 1 SD for each taxonomic group (molluscs = 4.29; algae = 4.37) highlighted large environmental or habitat changes such as major estuaries, cities, headlands or large islands, particularly those along the south coast of England and the west of Scotland. There were 50 transitions exceeding the mean + SD criterion for molluscs and 47 cases for algae. Though of regional interest, the relatively high number of mean + SD transitions may contain false positives and merits further investigation. For simplicity, we concentrated on the most extreme changes in species richness between grid squares. There were 3 changes in species richness between grid squares (4 for molluscs) that were outliers in terms of the magnitude of the transition (exceeding a change of 20 for mollusc species richness and 22 for algal species richness). These transition points are presented as breakpoints representing the largest grid square–grid square transitions in the smoothed data.

Having removed a mesoscale signal by fitting a trend surface, the remaining signal is contained in the residuals. This local signal was expected to reflect variation between 10 km squares in habitat and collection effort. The influences of the additional predictor variables of collection effort, wave exposure, variance in

wave exposure and coastline length were examined using multiple regression. The total number of records and the number of different record dates recorded in a grid square were taken as proxies for collection effort. For a first approximation, coastline length and variance in wave exposure were assumed to be measures of habitat diversity. A relatively long coastline length within a grid square implies indentations in the coastline, potentially leading to a diversity of habitats. Similarly, if a grid square has a relatively high variation in exposure, this implies a diversity of exposed and sheltered habitats. Wave exposure values were taken from the dataset produced by Burrows et al. (2008). Values are based on total fetch and are calculated at a spacing of every 200 m around the coast of the UK. Variables were natural log-transformed before model fitting, as examination of residual plots suggested this was appropriate. Wave exposure data were transformed using $x^{0.277}$, as a plot of variance against mean suggested that this transformation would minimize the dependency between the mean and variance (Legendre & Legendre 1998).

Trend surface fitting was carried out in the SAM software package (Rangel et al. 2006). An information theoretic approach based on comparisons of Akaike's information criterion (AIC) was used to choose an optimum level of complexity in multiple regression analyses (Burnham & Anderson 2004). The lowest value of AIC in a set of models defines the model with the best fit for the lowest level of model complexity. AIC values were also used in an averaging process when examining the influence of the potential predictor values on species richness. This averaging approach reflects the practicalities of comparing models that may have similar predictive power, such that a choice of the 'best' model may discard information in related models. When models are compared using AIC as a measure of fit, each model can be compared to the best model (lowest AIC) and given a weighting, equivalent to a probability that the model is the best one in the set of candidate models (Johnson & Omland 2004). The probability weighting based on relative AIC values reflects the origin of AIC in maximum likelihood theory and is known as an Akaike weight. Comparisons of Akaike weights among different models highlight the more consistently influential predictor variables. A more formal comparison of alternative predictor variables is made by comparing a quantity known as the average importance. The average importance of each variable is the sum of Akaike weights for all models containing that variable (Burnham & Anderson 2004). A high importance (up to a maximum of 1) for a variable therefore indicates that it occurred in the most powerful predictive models. We therefore present model comparisons using the average importance for

different predictor variables, alongside AIC values as a measure of model fit. Comparisons of AIC values used the small sample corrected version of the information criterion, AIC_c .

RESULTS

There are 852 squares of 10 km around the UK that include a stretch of coastline. For 615 of these squares, there were records of littoral algae, with 642 having information on littoral molluscs. Most of the surveyed squares with no littoral species records were along the east coast of England and Scotland, particularly Suffolk, Norfolk, Lincolnshire, Angus and Kincardineshire. These grid squares were treated as missing values rather than zeroes. There were 115 035 entries for littoral algae around the UK, consisting of a total of 729 species, and 66 879 entries for littoral molluscs with a total of 569 species.

Trend surface fits for first order polynomials demonstrated significant south–north and west–east declines in predicted species richness for both algae and molluscs. A simple linear decline with distance from the southwest was not a sufficient descriptor of the pattern, judging from the lower AIC_c values for more complex polynomial trend surfaces (Table 1). Final trend surfaces had 17 predictor variables for algae and 22 for molluscs. The fitted trend surfaces are a smoothed representation of the raw data, so it is unsurprising that

Table 1. Comparative trend surface model-fitting results for surfaces of increasing complexity. All terms were fitted in the polynomial models except the optimum, which was reached by backwards elimination of non-significant terms. All fitted models were statistically significant at $p < 0.05$.

AIC_c : corrected Akaike's information criterion

Response variable Fitted model	r^2	F	AIC_c	Predictor variables
Molluscan species richness (n = 642)				
1st order polynomial	0.031	10.3	1899.7	2
2nd order polynomial	0.088	12.3	1866.8	5
3rd order polynomial	0.139	11.4	1838.2	9
4th order polynomial	0.203	11.4	1799.4	14
5th order polynomial	0.252	10.5	1770.7	20
6th order polynomial	0.284	9.0	1757.9	27
Optimum model	0.282	11.1	1749.1	22
Algal species richness (n = 615)				
1st order polynomial	0.024	7.4	1869.2	2
2nd order polynomial	0.083	11.1	1836.3	5
3rd order polynomial	0.137	10.7	1807.3	9
4th order polynomial	0.205	11.1	1767.4	14
5th order polynomial	0.240	9.4	1752.6	20
6th order polynomial	0.250	7.2	1759.8	27
Optimum model	0.236	10.9	1749.1	17

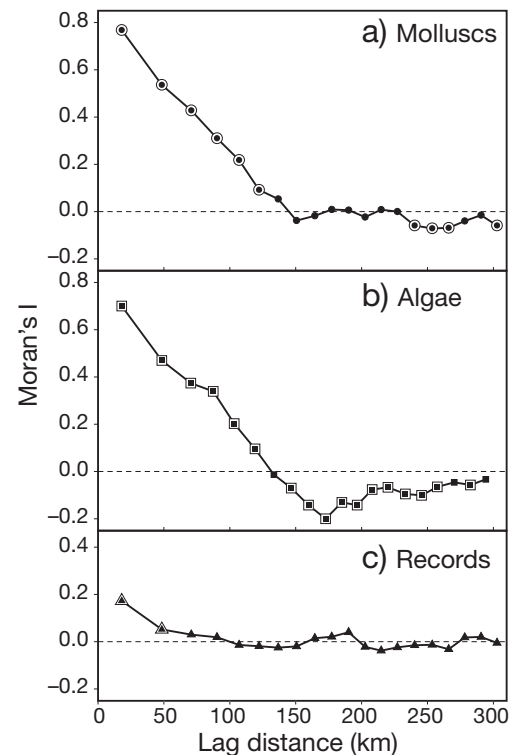

Fig. 1. Spatial autocorrelation (Moran's I) in the trend surface modelled for (A) molluscan species richness, (B) algal species richness and (C) records per grid cell. Symbols with a border represent significant autocorrelation at the related lag distance ($p < 0.05$), following a Bonferroni correction for multiple tests within each correlogram

predicted species richness values for algae and molluscs are autocorrelated (Fig. 1). Positive autocorrelation extended to approximately 120 km in algae and molluscs. The autocorrelation function is a mesoscale summary of spatial pattern, suggesting that, on average, the length scale for areas of relatively high or low species richness was about 120 km. The spatial patterns in fitted mollusc and algal species richness were more defined than those for collection effort. The autocorrelation of record numbers extended over approximately 50 km. Residuals from the trend surface analyses had no pattern of spatial autocorrelation.

The smoothed patterns of species richness for algae and molluscs were broadly congruent ($r = 0.582$, $df = 270.3$, $p < 0.001$; note that df is not in integer form, as the Dutilleul 1993 method was used to correct for spatial autocorrelation), with some small differences (Fig. 2). For molluscs, the most diverse squares were along the south coast of England, the Scilly Isles and in the Inner Hebrides, particularly around the Isle of Skye. Reducing the cut-off percentage from the top 10% to the top 5% of grid squares emphasized the richness of the south coast of England and the Scilly Isles. Algae were also diverse along the south and



Fig. 2. Spatial patterns of (A,B) molluscan and (C,D) algal species richness around the UK in the fitted trend surfaces. Symbols are scaled to emphasize areas with high predicted species richness. Dots represent 10 km grid squares where the corresponding taxon has been recorded. Large circles are given where a 10 km grid square falls within the most diverse squares in the database. Threshold values for the larger symbols are set to emphasize different cut-off points—(A,C) most diverse 10% of 10 km squares, (B,D) most diverse 5% of 10 km squares

southwestern coasts of England and the Scilly Isles, with additional areas of relatively high richness in southwest Wales, Northern Ireland and the east coast of Scotland.

The largest square–square transitions in species richness occurred between the Scilly Isles and Cornwall and along the southern coast of England (Fig. 3). These breakpoints represent drops in species richness moving eastwards from the Isles of Scilly and in the region of Start Point, Devon. There was also a sudden



Fig. 3. Locations of the largest changes in species richness (breakpoints) between adjacent 10 km grid squares for (A) molluscs and (B) algae: (1) Isles of Scilly and Cornwall, (2) Start Point, (3) Portland Bill and (4) Beachy Head. Moving from west to east, the patterns are: (1,2) sharp decrease in species richness; (3,4) sharp increase and then decrease in species richness

increase and subsequent drop in algal species richness around Beachy Head, Sussex. There was a similar rise and fall in species richness of molluscs in the region of Portland, Dorset.

The residual (local) variation in species richness around the fitted trend surfaces was related to collection effort proxies and local habitat variables, with the best-fitted model explaining a high proportion of the

Table 2. Model averaging results for variation in the trend surface analysis residuals for molluscan and algal species richness. A total of 31 models were compared, using Akaike weights to estimate the relative importance of different predictors and weighted average coefficient values. The best model for molluscs had 4 predictor variables with a corrected Akaike's information criterion (AIC_c) of 1042 and an r^2 of 0.65. The best model for algae also had the same 4 predictor variables with an AIC_c of 990 and an r^2 of 0.70

Predictor variable	Importance	Standardized coefficient	In best model?
Molluscan species richness			
Dates	0.951	-0.106	Y
Records	1	0.867	Y
Mean exposure	0.477	-0.04	N
Variance of exposure	0.606	-0.044	Y
Coastline length	0.759	0.059	Y
Algal species richness			
Dates	0.89	-0.089	Y
Records	1	0.886	Y
Mean exposure	0.419	-0.038	N
Variance of exposure	0.996	-0.1	Y
Coastline length	0.966	0.087	Y

residual variation ($r^2 = 0.65$ for molluscs, 0.70 for algae; Table 2). Proxies for collection effort were the most important variables, particularly the total number of records within a grid square. While the number of records had a positive effect on the number of species recorded, the number of survey dates had a weaker negative effect on the recorded richness. Coastline length had a positive effect on species richness and was generally the most important of the habitat variables examined. Exposure variables (mean and variance) had negative effects on species counts from grid squares. The importance of coastline and exposure variables in the averaged models indicates that the local variation in species richness was driven by more than just variability of sampling effort.

DISCUSSION

Fitting a trend surface to the dataset emphasizes the mesoscale variability in species richness around the coastline. Latitudinal gradients exist within the overall patterns, but their strength is altered at regional scales by other features, such as the response to large estuaries or areas of less species-rich habitat (Hillebrand 2004). The mesoscale features in the UK species richness dataset do not appear to be driven by collection effort, as the available proxies for collection show concentration of effort at smaller spatial scales. There was a marked influence of collection effort on the residual variation in species richness at grid square scales. Habitat variables, however, also had predictive power at these scales, implying that local variation in species richness may be influenced by variables such as habitat heterogeneity or area within a 10 km square.

The analyses presented in the present study differ from previous research in the source of distribution data. Desk-based studies have often used range limit data to define the richness in different areas (e.g. Macpherson 2002). This approach potentially biases patterns of species richness to the centre of the region considered, and does not contain data on gaps in species' distributions (Gaines & Lubchenco 1982). Ideally, patterns of variation in diversity would be defined from standardized surveys, reducing the potential for collection effort and other biases to influence the results. Unfortunately, the resources to carry out such surveys will always be limited. It is not surprising that the authors of large replicated studies of biodiversity describe the survey work as 'unprecedented' (Schoch et al. 2006, Blanchette et al. 2008). The database record approach presented in the present study emphasizes some of the same information that intensive field surveys can show. For example, Blanchette et al. (2008) concluded that biogeographical regions along the

Pacific coast of North America were separated by changes in coastline orientation and/or stretches of unfavourable habitat, a situation similar to the breakpoints identified along the southern coastline of England. The advantage with collating data from species records is that the analysis uses contiguous grid squares at a relatively fine resolution (10 km). This adds greater resolution to the identification of pattern when compared to field surveys that may have average separations between sites exceeding 70 km (Bus-tamante & Branch 1996, Blanchette et al. 2008). The disadvantage of using collated records is that sampling is not standardized; therefore, habitat-specific associations may be lost and analyses using abundance as well as species presence are not possible. Furthermore, using collated records introduced uncontrolled biases and errors in the spatial distribution of effort and skill.

The main proxies for collection effort in the present study were number of records and number of separate record dates. Not surprisingly, species richness was positively associated with collection effort proxies. For molluscs, the number of records was correlated with both the fitted TSA ($r = 0.378$) and the residuals from the TSA ($r = 0.799$). Equivalent correlations for algal richness were 0.467 for the smoothed surface and 0.822 for the residuals. Associations with collection effort were therefore much stronger in the residual pattern, implying that collection effort had a greater influence at the 10 km scale than in the smoothed patterns of the trend surface. As shown in Fig. 1, the TSA identifies features that extend over 100 km, while collection effort extends over a range of about 50 km. This implies that patches of high richness grid squares driven by phenomena such as the presence of a marine laboratory extend over a smaller area than the features identified by the trend surface. Taken together, the spatial autocorrelation evidence and relative strength of correlations coefficients both suggest that the smoothed data is less influenced by collection effort than the residual pattern and that the smoothed pattern therefore represents more than an artefact of historical sampling effort.

The causes of the mesoscale regional patterns of molluscs and algae are difficult to separate. Climate certainly plays a role. For example, the peak in mollusc species richness in the Inner Hebrides may reflect the warmer winters in the west and northwest of Scotland than in southern parts of the North Sea (Lewis et al. 1982). Habitat also seems likely to play a role, with regions of high diversity generally found away from estuaries (Burrows et al. 2008) or areas with extensive soft sediment. While habitat heterogeneity at 10 km grid cell scales (coastline length as a proxy) affected species richness (see also Archambault & Bourget 1996), the covari-

ance of climate makes it difficult to estimate the role of heterogeneity at larger scales. So it is unclear whether mesoscale species diversity is reduced as a result of the much less indented east coast of Great Britain when compared to the more complex west coast.

It is not clear why there should be a region of increased algal richness on the east coast of Scotland. This pattern does not appear to be associated with a particularly high collection effort. It may be that the quality of surveys in this area is relatively high, leading to more species per record. It is also relevant that the spacing of grid squares with records in this region is relatively sparse, so that the regional smoother is more influenced by the values from individual grid squares than elsewhere in the dataset.

Alternative methods of providing a smoother are possible: for example generalized additive models (GAMs) or a moving window. These methods do not suggest method-specific influences on the pattern identified. Fitted smoothers tended to produce very similar results to the trend surface analysis, with correlations between fitted values exceeding 0.88 (based on GAMs fitted with estimated df of 34.4 and 24.6 for molluscs and algae, respectively, and a square moving window of 13×13 grid squares).

The analyses in the present study are relevant to conservation-related attempts to define species diversity hotspots (Hiscock & Breckels 2007). There are no criteria for the deviation from the mean required to define a site as a hotspot. The fitted distributions for species richness were skewed to the right and we used a simple proportional approach to identify the most species-rich sites. By separating the spatial pattern into a regional and a local component, 2 levels can be used to define a hotspot. In Fig. 2, regions are shown to be species-rich (hotspot regions) or not. The residual score shows whether a grid square has relatively high or low species richness in comparison to the average species richness of that region. The more extreme residuals are scattered around the coastline. We extended this approach by making a correction for the number of records and using the residuals from this relationship to identify outlying grid squares of interest (Fig. 4). High richness regions do not generally contain further grid squares that are effort-corrected hotspots of relatively high diversity. If anything, the high diversity regions are more likely to contain local relative 'coldspots' of reduced diversity, although this is mostly an artefact of introducing a second predictor variable correlated to the TSA. What such analyses can do, however, is to highlight grid squares that may be of interest for conservation planning or further investigation.

An example of how different processes shape the relative variation in species richness can be given using the local estuarine hotspots (Fig. 4). There are at

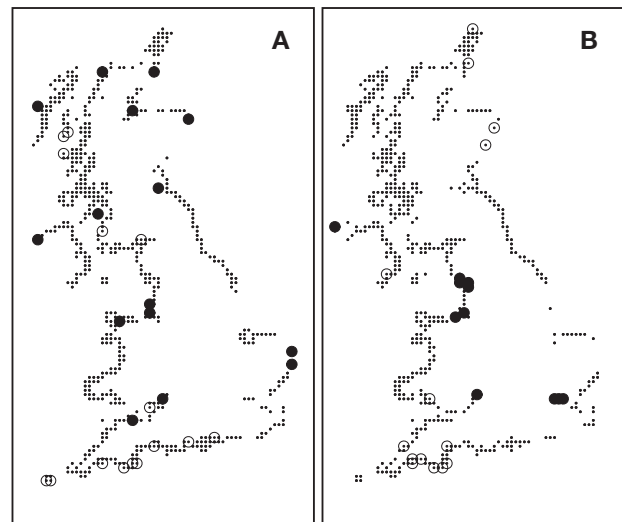

Fig. 4. Residual patterns of species richness following removal of the trend surface component in (A) molluscs and (B) algae. Large symbols are outliers falling in the upper or lower 5% of residual values following a regression to control for variation in record number within each 10 km square. (●) relatively high species richness hotspots; (○) relatively low species richness, 'cool spots'

least 3 hypotheses for why a 10 km square in an estuary may have relatively more species than the adjacent squares: (1) there may be a habitat such as an outcrop of rocky shore that adds to the local diversity compared to surrounding intertidal mud (this habitat may be artificial, such as marinas or harbour walls); (2) estuaries may have more introduced species due to an increased volume of shipping traffic; and (3) estuaries are closer to large conurbations and, therefore, may have had more detailed collection effort. Looking at species lists from the apparent estuarine hotspots in Fig. 4, Hypotheses 1 and 3 are supported, but the extent of support for each hypothesis varies in space. The apparent algal and molluscan hotspots in the Severn Estuary represent peaks in otherwise commonly recorded rocky shore species. These appear to reflect a 10 km square containing habitat otherwise rare in the estuary (one of the relevant site names is Aust Rocks). In contrast, the peak in mollusc species outside Edinburgh coincides with a Conchological Society field trip and includes records of widespread but rarely identified genera such as *Brachystomia*.

The most clearly defined changes in species richness between adjacent grid squares (breakpoints) occurred between the Scilly Isles and Great Britain and along the south coast of England. The Scilly Isles transition probably reflects the comparison between diverse exposed and sheltered habitats within a grid square to more uniform exposed habitat in the nearest grid square in southwest England. This large drop is there-

fore caused by the relatively low species richness at the southwestern tip of Great Britain. These squares did not feature in the most diverse 10% of sites. Therefore, there is no contradiction with the work of Turk & Seaward (1997). These authors found similar, if not higher, richness in southwest England compared to the Scilly Isles, but their study sites included the more species-rich areas beyond the southwestern tip of England. The breakpoint at Start Point also represents a marked decrease in species richness for algae and molluscs. Start Point is a barrier to the movement of mussel larvae (Gilg & Hilbish 2003), and east of the point there are large areas of beach. The brown alga *Bifurcaria bifurcata* also has a range limit in the region of Start Point (Mieszowska et al. 2006) and other species' range limits are also consistent with the breakpoints identified in the present study (e.g. Mieszowska et al. 2007). The features of potential hydrographic barriers and changes in habitat type or availability are present at the other breakpoints and have been identified by Herbert et al. (2009) as key features in restricting the distributions of intertidal species. Both Beachy Head and Portland Bill lie at the boundaries of coastal process cells, regions where sediment transport processes are largely independent (Motyka & Brampton 1993). Changes in habitat around Portland Bill include rock at the headland, but beaches to either side, particularly the extensive shingle bank to the west of Portland Head. Similarly, Beachy Head is formed by harder substrate, and likely represents better quality habitat for algae than the surrounding areas of softer bedrock.

Both species richness patterns and breakpoints are consistent with factors thought to limit the distribution of individual species. Lewis (1964) listed the unstable, erodible nature of substrata, turbidity, changes of aspect, small tidal ranges and strong currents (particularly those associated with headlands) as factors leading to limits of species ranges. Alongside broader climatic patterns, the factors listed by Lewis (1964) are consistent with the location and extent of the meso-scale patterns described in the present study. Our results support a view that much of the variability in intertidal diversity at mesoscales may be predicted from features of the physical environment (salinity, temperature, fetch; Zacharias & Roff 2001). Features of the coastline (length and fetch variation) also seemingly affect species diversity at smaller (local) scales. Aspects yet to be considered are the turnover of species between areas of differing diversity and how the mesoscale patterns translate into variation in the function and resilience of ecological communities. The latter approach requires abundance data, and it is encouraging that preliminary analyses indicate that separation of physical and trophic influences on community structure is possible (Burrows et al. 2008).

Acknowledgements. A.J.B. was funded by a Department of Employment and Learning studentship. We are grateful to the British Phycological Society, the Conchological Society of Great Britain and Ireland and the National Museums Northern Ireland for access to high resolution records held on the National Biodiversity Network.

LITERATURE CITED

- Archambault P, Bourget E (1996) Scales of coastal heterogeneity and benthic intertidal species richness, diversity and abundance. *Mar Ecol Prog Ser* 136:111–121
- Blanchette CA, Miner CM, Raimondi PT, Lohse D, Heady KEK, Broitman BR (2008) Biogeographical patterns of rocky intertidal communities along the Pacific coast of North America. *J Biogeogr* 35:1593–1607
- Briggs JC (1974) *Marine zoogeography*. McGraw-Hill, London
- Burnham KP, Anderson DR (2004) Multimodel inference: understanding AIC and BIC in model selection. *Sociol Methods Res* 33:261–304
- Burrows MT, Harvey R, Robb L (2008) Wave exposure indices from digital coastlines and the prediction of rocky shore community structure. *Mar Ecol Prog Ser* 353:1–12
- Bustamante RH, Branch GM (1996) Large scale patterns and trophic structure of southern African rocky shores: the roles of geographic variation and wave exposure. *J Biogeogr* 23:339–351
- Crisp DJ, Southward AJ (1958) The distribution of intertidal organisms along the coasts of the English Channel. *J Mar Biol Assoc UK* 37:157–208
- Dutilleul P (1993) Modifying the *t* test for assessing the correlation between two spatial processes. *Biometrics* 49: 305–314
- Ehler C, Douvère F (2009) *Marine spatial planning: a step-by-step approach toward ecosystem-based management*. IOC Manual and Guides No. 53, ICAM Dossier No. 6, UNESCO, Paris
- Gaines SD, Lubchenco J (1982) A unified approach to marine plant–herbivore interactions. 2. Biogeography. *Annu Rev Ecol Syst* 13:111–138
- Gilg MR, Hilbish TJ (2003) The geography of marine larval dispersal: coupling genetics with fine-scale physical oceanography. *Ecology* 84:2989–2998
- Gouhier TC, Guichard F (2007) Local disturbance cycles and the maintenance of heterogeneity across scales in marine metapopulations. *Ecology* 88:647–657
- Harrison S, Cornell H (2008) Toward a better understanding of the regional causes of local community richness. *Ecol Lett* 11:969–979
- Herbert RJH, Southward AJ, Clarke RT, Shearer M, Hawkins SJ (2009) Persistent border: an analysis of the geographic boundary of an intertidal species. *Mar Ecol Prog Ser* 379: 135–150
- Hillebrand H (2004) Strength, slope and variability of marine latitudinal gradients. *Mar Ecol Prog Ser* 273:251–267
- Hillebrand H, Blenckner T (2002) Regional and local impact on species diversity: from pattern to processes. *Oecologia* 132:479–491
- Hiscock K, Breckels M (2007) *Marine biodiversity hotspots in the UK. A report identifying and protecting areas for marine biodiversity*. WWF, Godalming
- Johnson JB, Omland KS (2004) Model selection in ecology and evolution. *Trends Ecol Evol* 19:101–108
- Johnson MP, Crowe TP, McAllen R, Allcock AL (2008) Characterising the marine Natura 2000 network for the Atlantic region. *Aquat Conserv* 18:86–97

- Kinlan BP, Gaines SD (2003) Propagule dispersal in marine and terrestrial environments: a community perspective. *Ecology* 84:2007–2020
- Legendre P, Legendre L (1998) Numerical ecology. Developments in Environmental Modelling 20. Elsevier Science, Amsterdam
- Levin SA (1992) The problem of pattern and scale in ecology. *Ecology* 73:1943–1967
- Lewis JR (1964) The ecology of rocky shores. English Universities Press, London
- Lewis JR, Bowman RS, Kendall MA, Williamson P (1982) Some geographical components in population dynamics: possibilities and realities in some littoral species. *Neth J Sea Res* 16: 18–28
- Lüning K (1990) Seaweeds: their environment, biogeography and ecophysiology. John Wiley, New York
- Macpherson E (2002) Large-scale species richness gradients in the Atlantic Ocean. *Proc Biol Sci* 269:1715–1720
- Mieszkowska N, Kendall MA, Hawkins SJ, Leaper R, Williamson P, Hardman-Mountford NJ, Southward AJ (2006) Changes in the range of some common rocky shore species in Britain: a response to climate change? *Hydrobiologia* 555:241–251
- Mieszkowska N, Hawkins SJ, Burrows MT, Kendall MA (2007) Long-term changes in the geographic distribution and population structures of *Osilinus lineatus* (Gastropoda: Trochidae) in Britain and Ireland. *J Mar Biol Assoc UK* 87:537–545
- Motyka JM, Brampton AH (1993) Coastal management: mapping of littoral cells. Report SR 328. HR Wallingford, Oxford
- Rangel TFLVB, Diniz-Filho JAF, Bini LM (2006) Towards an integrated computational tool for spatial analysis in macroecology and biogeography. *Glob Ecol Biogeogr* 15:321–327
- Ricklefs RE (1987) Community diversity: relative roles of local and regional processes. *Science* 235:167–171
- Rivadeneira MM, Fernández M, Navarrete SA (2002) Latitudinal trends of species diversity in rocky intertidal herbivore assemblages: spatial scale and the relationship between local and regional species richness. *Mar Ecol Prog Ser* 245:123–131
- Saunders SC, Chen JQ, Drummer TD, Gustafson EJ, Brosofske KD (2005) Identifying scales of pattern in ecological data: a comparison of lacunarity, spectral and wavelet analyses. *Ecol Complex* 2:87–105
- Schoch GC, Menge BA, Allison G, Kavanaugh M, Thompson SA, Wood SA (2006) Fifteen degrees of separation: latitudinal gradients of rocky intertidal biota along the California Current. *Limnol Oceanogr* 51:2564–2585
- Smith SDA (2005) Rapid assessment of invertebrate biodiversity on rocky shores: where there's a whelk there's a way. *Biodivers Conserv* 14:3565–3576
- Turk SM, Seaward DR (1997) The marine fauna and flora of the Isles of Scilly—Mollusca. *J Nat Hist* 31:555–633
- Willis KJ, Whittaker RJ (2002) Species diversity—scale matters. *Science* 295:1245–1248
- Zacharias MA, Roff JC (2001) Explanations of patterns of intertidal diversity at regional scales. *J Biogeogr* 28:471–483

Accepted: May 2, 2009; Submitted: October 20, 2009;

Proofs received from author(s): November 20, 2009



Consequences of climate-driven biodiversity changes for ecosystem functioning of North European rocky shores

S. J. Hawkins^{1,2,*}, H. E. Sugden¹, N. Mieszkowska², P. J. Moore^{2,3}, E. Poloczanska⁴, R. Leaper⁵, R. J. H. Herbert^{6,7}, M. J. Genner^{2,8}, P. S. Moschella^{2,9}, R. C. Thompson¹⁰, S. R. Jenkins^{1,2}, A. J. Southward^{2,†}, M. T. Burrows¹¹

¹School of Ocean Sciences, Bangor University, Menai Bridge, Anglesey LL59 5AB, UK

²Marine Biological Association of the UK, The Laboratory, Citadel Hill, Plymouth PL1 2PB, UK

³School of Natural Sciences, Edith Cowan University, Joondalup, Western Australia 6027, Australia

⁴Climate Adaptation Flagship, CSIRO Marine & Atmospheric Research, PO Box 120, Cleveland, Queensland 4163, Australia

⁵Commonwealth Environment Research Facilities Program Marine Biodiversity Hub: Prediction Program, Tasmanian Aquaculture and Fisheries Institute, University of Tasmania, Locked Bag 49, Hobart 7001, Australia

⁶Medina Valley Field Centre, Dodnor Lane, Newport, Isle of Wight PO30 5TE, UK

⁷School of Conservation Sciences, Bournemouth University, Christchurch House, Talbot Campus, Poole, Dorset BH12 5BB, UK

⁸School of Biological Sciences, University of Bristol, Woodland Road, Bristol BS8 1UG, UK

⁹CIESM – The Mediterranean Science Committee, 16 bd de Suisse, MC 98000, Monaco

¹⁰Marine Biology and Ecology Research Centre, Marine Institute, University of Plymouth, Drake Circus, Plymouth PL4 8AA, UK

¹¹Scottish Association for Marine Sciences, Dunstaffnage Marine Laboratory, Oban, Argyll PA37 1QA, UK

ABSTRACT: We review how intertidal biodiversity is responding to globally driven climate change, focusing on long-term data from rocky shores in the British Isles. Physical evidence of warming around the British Isles is presented and, whilst there has been considerable fluctuation, sea surface temperatures are at the highest levels recorded, surpassing previous warm periods (i.e. late 1950s). Examples are given of species that have been advancing or retreating polewards over the last 50 to 100 yr. On rocky shores, the extent of poleward movement is idiosyncratic and dependent upon life history characteristics, dispersal capabilities and habitat requirements. More southern, warm water species have been recorded advancing than northern, cold water species retreating. Models have been developed to predict likely assemblage composition based on future environmental scenarios. We present qualitative and quantitative forecasts to explore the functional consequences of changes in the identity, abundance and species richness of gastropod grazers and foundation species such as barnacles and canopy-forming algae. We forecast that the balance of primary producers and secondary consumers is likely to change along wave exposure gradients matching changes occurring with latitude, thereby shifting the balance between export and import of primary production. Increases in grazer and sessile invertebrate diversity are likely to be accompanied by decreasing primary production by large canopy-forming furoids. The reasons for such changes are discussed in the context of emerging theory on the relationship between biodiversity and ecosystem functioning.

KEY WORDS: Climate change · Intertidal · Range shifts · Biodiversity · Ecosystem functioning · Northeast Atlantic

Resale or republication not permitted without written consent of the publisher

INTRODUCTION

Marine biodiversity and ecosystems are responding to global climate change (Southward et al. 1995, Hawkins et al. 2003, Parmesan & Yohe 2003). Major shifts

in the distribution of plankton (Beaugrand et al. 2002, Beaugrand & Reid 2003), fish (Perry et al. 2005, Dulvy et al. 2006), subtidal benthic invertebrates (e.g. Ling et al. 2008, Ling et al. 2009) and intertidal species (see Harley et al. 2006, Helmuth et al. 2006 for reviews)

*Email: s.hawkins@bangor.ac.uk

†Deceased

have been recorded in recent years. Coastal and near-shore biodiversity loss is also occurring due to regional and local-scale impacts (see e.g. Ling 2008, Polunin 2008 for reviews) such as overfishing and its side effects (Kaiser et al. 2007), pollution (Terlizzi et al. 2005), recreational pressures (Gray 1997, Dayton et al. 2005) and habitat loss due to coastal development (Airoidi & Beck 2007). Direct responses of biodiversity to global climate-driven change are superimposed on these smaller-scale processes. There are growing local-scale impacts due to human mitigational responses to climate change (e.g. offshore windfarms) which will increase further as tidal and wave energy schemes come on stream. Human adaptation to climate change will also impact coastal ecosystems, particularly as coastal defences (Airoidi et al. 2005, Burcharth et al. 2007) proliferate in response to rising sea levels and stormier seas (Bindoff et al. 2007).

Here we take a synoptic view of changes in intertidal biodiversity in response to climate change (updating Helmuth et al. 2006) and explore the implications of these changes for ecosystem functioning, building on Hawkins et al. (2008). We draw on a combination of published and unpublished long-term studies, modelling and experiments to synthesize changes underway in intertidal biodiversity and forecast their likely consequences for ecosystem functioning. Our focus is the intertidal zone of the North East Atlantic, particularly the British Isles and Ireland, for which there are extensive historical data sets and a rich history of experimental studies (reviewed in Southward et al. 1995, 2005, Helmuth et al. 2006, Hawkins et al. 2008). Recent national (e.g. Marine Environmental Change Network and MarClim in the UK) and European networks (e.g. MarBEF LargeNet) have helped retrieve and collate much of the data discussed below. We only consider responses to temperature and associated environmental variables and increased storminess for which there are reasonable predictions of future states on a 25 to 100 yr time scale (summarised in IPCC 2007). To keep the review manageable, the impacts of reducing pH of the oceans are not considered. Furthermore, such impacts are also likely to act on a longer time scale (50 to 100+ yr), although recent work has emphasized that significant changes could occur much more rapidly than originally anticipated, and may even be under way (Wootton et al. 2008).

We first outline historic fluctuations and changes in abundance and geographic distribution that are underway at the species level, before suggesting potential trajectories over the next 50 to 100 yr. Contrasts are made between advancing southern species and northern species that are likely to retreat. The species-specific nature of these changes are highlighted (see also Helmuth et al. 2006). We consider

assemblage level changes by synthesising summaries of published work on the role of biological interactions in modulating climate change responses (Poloczanska et al. 2008) and give a preliminary report of statistically based modelling of the response of functionally important canopy-forming fucoids to rising temperatures and stormier seas. The mechanisms involved are discussed and gaps in knowledge and uncertainties identified. We speculate on the likely consequences for biodiversity of the loss of major habitat-forming canopy species as well as implications for the balance between primary and secondary production along wave action and latitudinal gradients. Present and future patterns and underlying processes are then placed in the context of emerging theory on the relationship between biodiversity and ecosystem functioning (Hector et al. 1999, Loreau et al. 2002, Hooper et al. 2005, Balvanera et al. 2006), derived primarily from terrestrial studies (e.g. Naeem et al. 1996, Tilman et al. 2006) but also aquatic systems (see Emmerson et al. 2001, Naeem 2006, Solan et al. 2006, Griffin et al. 2008). Counter to theory, increasing biodiversity of grazers is likely to be accompanied by decreasing productivity of canopy-forming algae—reasons for this apparent paradox are discussed.

SPECIES DISTRIBUTIONS: PAST AND PRESENT

Environmental context

Fig. 1 shows the sea surface temperatures (SST) since 1870 at key locations around the British Isles. Those for Plymouth are shown separately for clarity, as most ecological data are available for this region, with time series stretching back 50 to 100 yr (see Southward 1980, Southward et al. 1995, 2005, Hawkins et al. 2003 for reviews). These data illustrate that the western side of the UK is warmer than the colder waters of the North Sea and Eastern Channel (see also Sheppard 2004, Woehrling et al. 2005). Considerable interannual and interdecadal variation is also shown, with warm periods (end of the 19th and beginning of the 20th century, and the late 1950s) followed by switches to colder temperatures. From the 1920s onwards, there was a period of warming but with much fluctuation until 1962, when, following the extreme winter of 1962–1963 (Crisp 1964), conditions were generally much cooler until the mid-1980s. Since 1987, conditions have become much warmer, typified by milder winters due to prevalence of positive North Atlantic Oscillation index years, with predominantly westerly air flow in winter across northern Europe (Mackenzie & Schiedek 2007).

Over the last 100 yr, climate has driven major fluctuations and distributional shifts in this region (e.g. South-

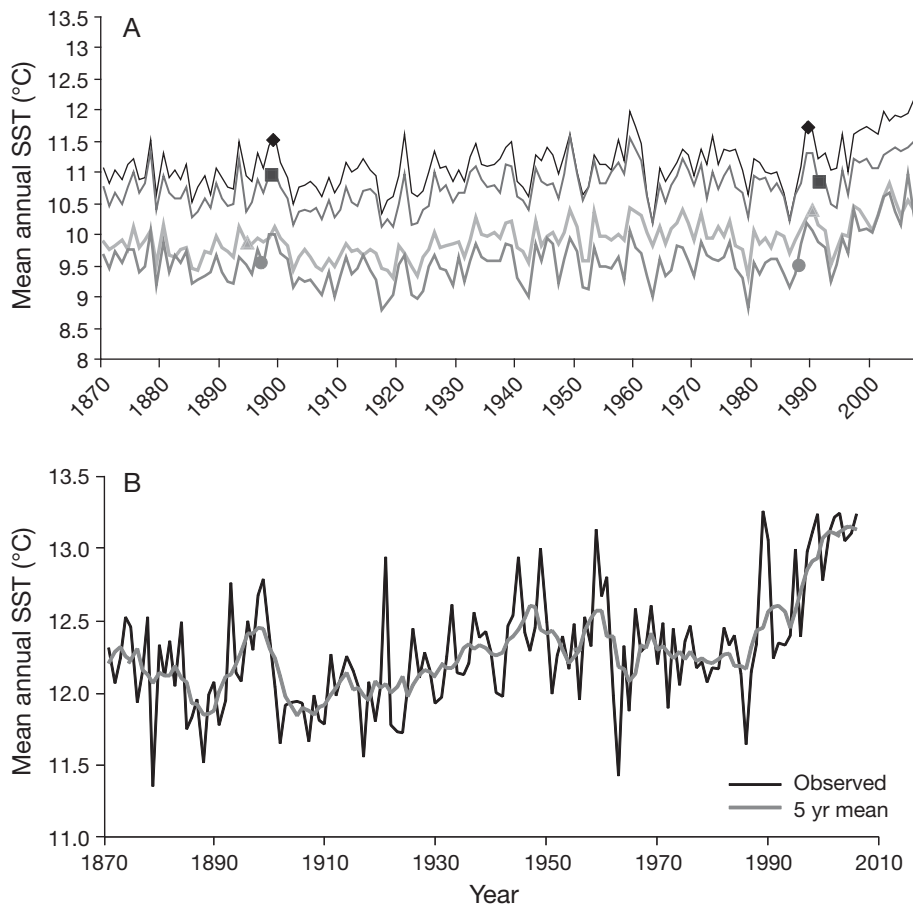

Fig. 1. Average yearly sea surface temperature (SST) from 1870 to 2008 at (A) 4 locations in the UK, marked on map: Isle of Man (\blacklozenge), southwest Scotland (\blacksquare), north Scotland (\blacktriangle) and southeast Scotland (\bullet); and (B) Plymouth ($*$) (note change of scale to highlight fluctuations), shown separately for clarity, as a high proportion of long-term ecological data are from this region. Data from the UK Met Office Hadley Centre HadSST2 data set (see also Sheppard 2004, Rayner et al. 2006)

ward 1980). In recent years, poleward shifts with associated increases in abundance of southern species and reductions in northern species have been observed in plankton (Beaugrand et al. 2001), fish (Beare et al. 2004, Genner et al. 2004, Perry et al. 2005) and benthos (Hiscock et al. 2004). Phenological shifts in relation to climatic fluctuations have been observed in plankton (Edwards & Richardson 2004) and nekton (Sims et al. 2001, 2004). Many of these changes in offshore systems have been paralleled onshore, which is perhaps not surprising given the prevalence of pelagic early life-stages of most intertidal species (Southward et al. 2005). Thus the intertidal zone can be considered a proxy for broad-scale changes in nearshore waters, with the added bonus of being easy to access, inexpensive to sample and experimentally tractable, allowing explorations of underlying processes. Hence we focus on intertidal systems in the present study.

Historical patterns

It has long been known that numerous marine species reach their biogeographic limits around the British Isles (Forbes 1858). Warm-water southern species ex-

tend northwards from the Atlantic coasts of North Africa and the Mediterranean, just reaching the coasts of Britain and Ireland, while a lesser number of cold-water northern boreal species have their southern distributional limits at the same latitudes (Southward & Crisp 1954a, Crisp & Southward 1958, Lewis 1964, Southward et al. 1995, Hiscock et al. 2004). Thus a boundary zone straddles the British Isles: many species reach their recorded poleward limits in the western English Channel between Plymouth and the Isle of Wight, between St. David's Head in South Wales and Anglesey in North Wales, on the northwest coast of Ireland or on the western and northern coasts of Scotland. Some species extend around the north of Scotland and penetrate into the colder waters of the North Sea (e.g. *Chthamalus* spp., Crisp et al. 1981). There are also some southern species which have reached northern France but have not crossed the Channel (e.g. *Haliotis tuberculata* and *Gibbula pennanti*). Conversely, some northern cold water species have become very rare in the south and west of Britain and Ireland, although they can re-appear in greater abundance further south in Europe in colder waters around Brittany (e.g. *Alaria esculenta*) and in areas with upwelling in northern Spain and Portugal (fucoid algae, *Semibalanus bala-*

noides). There are also boreal species such as *Strongylocentrotus droebachiensis* and the *Fucus distichus* complex that have been recorded as far south as Shetland and Orkney and the northern Scottish mainland (Lewis 1964, Southward et al. 1995).

Recent changes

Biogeographic range limits of many of the species described above were remarkably stable over much of the latter half of the 20th century (Crisp & Southward 1958, Lewis 1964, Southward et al. 1995), particularly in the region of the mid English Channel from Portland Bill to the Isle of Wight. Some trimming of ranges of southern species did take place following mortalities during the extremely cold winter of 1962–1963 (Crisp 1964), particularly in North Wales. During this period, some of the most striking changes were not in range shifts, but instead changes in abundance that took place in many species, including barnacles (Southward 1967, 1991) and limpets (Kendall et al. 2004).

Over the last decade, there have been some recent major range extensions in response to warming from the early 1990s onwards. In parallel, relative abundances of warm-water species have increased, and those of northern species have declined. Table 1 summarises these changes for key species. Southern trochids (*Osilinus lineatus*, *Gibbula umbilicalis*) have increased in abundance and their ranges have extended in northern Scotland, Northern Ireland, North Wales and the eastern English Channel (Mieszkowska et al. 2007). A southern species of limpet, *Patella depressa*, which decreased in abundance in the 1980s compared to the 1950s (Kendall et al. 2004), has largely recovered to the levels of abundance in the previous warm period in the 1950s. In some places it is now much more common, although it has not re-extended in great numbers beyond the Llyn Peninsula in North Wales. *Chthamalus* species have increased in abundance and *Semibalanus balanoides* has declined (Southward 1991). The recorded ranges of *Patella ulyssiponensis*, *Melarhapha neritoides* and *Perforatus (Balanus) perforatus* (Herbert et al. 2003) have also extended eastwards along the English Channel coast. The most spectacular advances have been in the trochid *G. umbilicalis* along the English Channel coast; it now reaches Kent, an eastward extension of over 240 km. In contrast, *Chthamalus* species have not breached the barrier of the Isle of Wight (Herbert et al. 2007, 2009).

Further south in Europe, there has been evidence of a northward range extension of southern species. *Patella rustica* was previously absent from the cold upwelling region of northern Portugal and Galicia, but reappeared on the warmer Basque coast (e.g. Fischer-

Piette 1936, 1955). Recently, this species has penetrated a dispersal barrier in northern Portugal associated with relaxation of upwelling (Lima et al. 2006, 2007b). Algal species have expanded or contracted northwards since the 1960s (Lima et al. 2007a). Southern species have generally advanced poleward; the picture is less clear for northern species, with both advances and retreats relative to baselines established by surveys during the 1950s and 1960s by Ardré (1971). Geographic range extensions and contractions are likely to continue into the future. The complex topography of the British Isles, with many sea gaps (i.e. between France and England, Ireland and Scotland) and stretches of soft coast providing barriers to dispersal, may hinder spread of rocky shore species which could live further north (Kendall et al. 1987).

Similar changes have been recorded in the intertidal and shallow subtidal zones in various other locations around the world such as North America, Europe and Australia (see Harley et al. 2006, Helmuth et al. 2006, Parmesan 2006, 2007, Poloczanska et al. 2007; for reviews, see also Ling et al. 2008, 2009). There have also been die-offs of intertidal (Harley 2008) and subtidal benthos due to episodes of extreme high temperatures, particularly in the Mediterranean (Coma et al. 2009). Furthermore, wholesale shifts in rocky reef ecology have been observed in the vicinity of the south-eastern Australian climate change hotspot (after Poloczanska et al. 2007), whereby range extension of the habitat-modifying sea urchin *Centrostephanus rodgersii* has occurred (Ling et al. 2008).

CHANGES WITHIN ASSEMBLAGES, AND FORECAST OF FUTURE COMMUNITY STATES

Most work on biological responses to climate change has concentrated on suites of individual species rather than on whole assemblages (but see Blight & Thompson 2008 for work on kelp holdfast assemblages). Hence there is a need to anticipate broader assemblage-level impacts by drawing inference from geographic comparisons reinforced by modelling and experimentation. In particular, the role of biological interactions in modelling climate-driven changes is crucial to fill this gap in understanding (Burrows & Hawkins 1998, Burrows et al. 2008, Poloczanska et al. 2008).

Climate and competitive interactions

The classic textbook example of competitive exclusion is the experimental work by Connell (1961) showing that the mid- and low-shore *Semibalanus balanoides* (then *Balanus balanoides*) outcompeted high

Table 1. Summary of range changes for key northern and southern rocky shore species around the British Isles and Ireland. Observations for species from further south in Europe are included where relevant for maps see Southward et al. 1995, updated from Helmuth et al. 2006)

Species	Previous range limits	New range limits	Extension/retreat	Comments	Source
<i>Gibbula umbilicalis</i>	North Scotland, Anglesey, Isle of Wight	Further east in north Scotland and north Wales	Extension	Breeding populations now present on the north coast of Scotland and along the English Channel beyond the Isle of Wight into Kent.	Mieszowska et al. (2006)
<i>Ostrea (Monodonta) lineatus</i>	Lyme Regis, Lleyn Peninsula	Spreading to Osmington, individual on Isle of Wight	Extension	Isolated individuals at Portland which disappeared in the 1960s. Breeding populations at Osmington and isolated individuals on Isle of Wight.	Mieszowska et al. (2007)
<i>Patella depressa</i>	Anglesey, Isle of Wight	Lleyn Peninsula Hayling Island	Limited re-extension	Dwelling populations on Anglesey in the 1980s compared to 1950s have not recovered north of Lleyn. South of Lleyn far more common. Limited extension in English Channel to Hayling.	Kendall et al. (2004)
<i>Chthamalus montagui</i>	Isle of Wight, Anglesey	Isle of Wight, Wirral	No change	Both <i>Chthamalus</i> species are more abundant up to range edges, but no major extensions despite suitable artificial habitat in English Channel. <i>C. montagui</i> found along north Wales coast to Wirral.	Crisp et al. (1981), Herbert et al. (2007, 2009), S. J. Hawkins (unpubl. data)
<i>Chthamalus stellatus</i>	Aberdeenshire, Isle of Wight, Anglesey	Fife Isle of Wight Isle of Man	Extension No change Extension	Previously absent from the Isle of Man, <i>C. stellatus</i> has recently been found.	Crisp et al. (1981), S. J. Hawkins (unpubl. data)
<i>Melarhaphe (Littorina) neritoides</i>	Isle of Wight, Flamborough Head	Kent Yarmouth Suffolk	Extension	Now found all around the UK. Present in East Anglia on sea defences and breakwaters.	S. J. Hawkins (unpubl. data)
<i>Perforatus (Balanus) perforatus</i>	Isle of Wight	Kent	Extension	Occurs both subtidally and on pier pilings.	Herbert et al. (2003)
<i>Bifurcaria bifurcata</i>	Dartmouth	Portland	Extension	Isolated populations found at Portland.	Mieszowska et al. (2006)
<i>Clibanarius erythropus</i>	Wembury	France	None to date	Expanded range at end of warm 1950s, eventually disappeared in late 1970s at end of cold spell. Has not yet recolonised.	Southward & Southward (1988)
<i>Tectura testudinalis</i>	Southern limit Irish Sea	Limits need verification	Retreat?	No longer found on south of the Isle of Man, possible retreat. Has been found on Anglesey and in Strangford.	Mieszowska et al. (2006), S. J. Hawkins, N. Mieszowska, Brazier (unpubl. data)
<i>Alaria esculenta</i>	Plymouth	Lizard Point	Retreat	Retreated in much of the western English Channel in the 1950s and did not recolonise in the colder 1960s–1980s. Further reduction in the abundance in the intertidal is occurring. Reductions in range and abundance in Ireland.	Simkanin et al. (2005), Mieszowska et al. (2006)
<i>Semibalanus (Balanus) balanoides</i>	Southern limit Galicia	Isolated population in Galicia	Retreat	Reduced abundance in the UK. Major reductions in southern limit.	Southward (1991), Wetthey & Woodin (2008)
<i>Patella vulgata</i>	Southern limit Portugal	Lower on Algarve	Retreat	Now less common in southwest England.	S. J. Hawkins (unpubl. data)
<i>Patella ulyssiponensis</i>	Isle of Wight	Beachey Head	Extension	Now found along south coast beyond Isle of Wight on artificial structures (Brighton Marina) and natural substrates.	S. J. Hawkins (unpubl. data)

shore *Chthamalus montagui* (then *C. stellatus*). Earlier, Southward & Crisp (1954a,b, 1956) had suggested that changes in climate mediate competition between these species (see Wethey 1980, 1982 for similar work on *S. balanoides* and *C. fragilis* in the UK and northeast USA). This work led to an extensive 40 yr time series (Southward 1967, 1991, Southward et al. 1995, 2005) encompassing 20 to 30 sites in southwest England, which showed fluctuations in counts of southern warm-temperature chthamalids (*C. stellatus* and *C. montagui* were split by Southward 1976) and the northern boreal-cold temperate *S. balanoides* were broadly linked to temperature with a lag of 1 to 2 yr on shores in southwest England.

Southward's data sets have been used as the basis of a statistical and mechanistic modelling study by Poloczanska et al. (2008) to make predictions of likely future climate scenarios on the outcomes of competition between these species (Fig. 2). A correlative study confirmed the lag of 2 yr with SST (Southward 1991), which was used as an integrative proxy for climatic conditions. This analysis also identified late spring/early summer as being the sensitive period. Moreover, using path analysis, the direct nature of the relationship of temperature with *Semibalanus balanoides* was highlighted; there was a highly significant negative effect of warm weather on numbers of *S. balanoides*, presumably acting on the vulnerable juvenile stage. In contrast, there was no significant direct effect on *Chthamalus* species (lumped in the analysis, but mainly *C. montagui* at the high and mid-levels analysed). There was, however, a very strong negative relationship with *S. balanoides*, indicating an indirect effect due to competition. Release from competition occurred in warm years.

Populations were simulated using a space-limited model based on the work of Roughgarden et al. (1985, 1994) and validated by hindcasting against the original time series. Various forms of the model were derived. A solely physically driven model simulated *Semibalanus* populations well, but *Chthamalus* numbers were only predicted accurately when interspecific competition was included in the model. On this basis, a model involving both temperature and competition was used to explore low and high emissions scenarios (UK Climate Impacts Programme [UKCIP], Hulme et al. 2002). Even under low emissions scenarios, *Semibalanus balanoides*, the species which was dominant in the southwest in the 1930s (Moore & Kitching 1939) is predicted to become locally extinct. It is, however, likely to persist in estuarine refuges and in coastal areas abutting deeper, colder water (Brittany, North Cornwall and Land's End; Crisp & Southward 1958) as it once did at the extreme south of its range in Spain (Wethey & Woodin 2008). Recent work by Wethey & Woodin

(2008) has shown that *S. balanoides* is virtually extinct in Galicia (northern Spain), just persisting in a few isolated locations. Under high emissions scenarios, *S. balanoides* will go locally extinct more quickly, scaling up to loss over much of the coastline of south and western Britain, southwest Ireland and Brittany. In estuaries, *S. balanoides* faces competition from *Elminius modestus*, which was not included in the models. This Australasian immigrant, that arrived and established 60 yr ago, has locally replaced *S. balanoides* as the dominant barnacle in areas of reduced salinity.

Responses of barnacles to changing climate have also been explored with other modelling approaches. Svensson et al. (2005) showed the importance of return frequency of failure years for population dynamics of the single annual brooding *Semibalanus balanoides*, drawing on data collected in a European-scale study of barnacle recruitment (Jenkins et al. 2000). Coupled matrix models of *Chthamalus montagui* (Hyder et al. 2001) and *S. balanoides* populations have also been used to explore future persistence in the face of recruitment variability (Svensson et al. 2006).

Changes in fucoïd canopies

In northern Europe, fucoïds predominate on sheltered shores, but can extend some way out into more exposed habitats (Lewis 1964). Further south they are more restricted to sheltered environments, with species such as *Fucus vesiculosus* eventually only being found in estuarine refuges (Ballantine 1961). In a warming world, the dynamic balance would be expected to shift from shores dominated by primary producing and shelter-providing fucoïds with their high associated biodiversity (Thompson et al. 1996), to suspension feeder (barnacles and mussels) dominated areas with many limpets and other grazers, as in southern Europe (Ballantine 1961, Southward et al. 1995). This trend would be reinforced by stormier seas which are also predicted (Bindoff et al. 2007). Thus we have undertaken preliminary statistically based modelling studies on how changes in wave action and temperature should influence the distribution of canopy-forming fucoïd species.

The MarClim project undertook broad-scale surveys of much of the coastline of the British Isles and Ireland. In parallel with this work, Burrows et al. (2008) derived an algorithmic tool to predict wave exposure based on an extension of the map-based method devised by Thomas (1986). This can predict exposure to wave action down to a resolution of approximately 200 m on a European scale. The MarClim data set of categorical abundance of fucoïds was then related to wave exposure using a multinomial logistic regression approach.

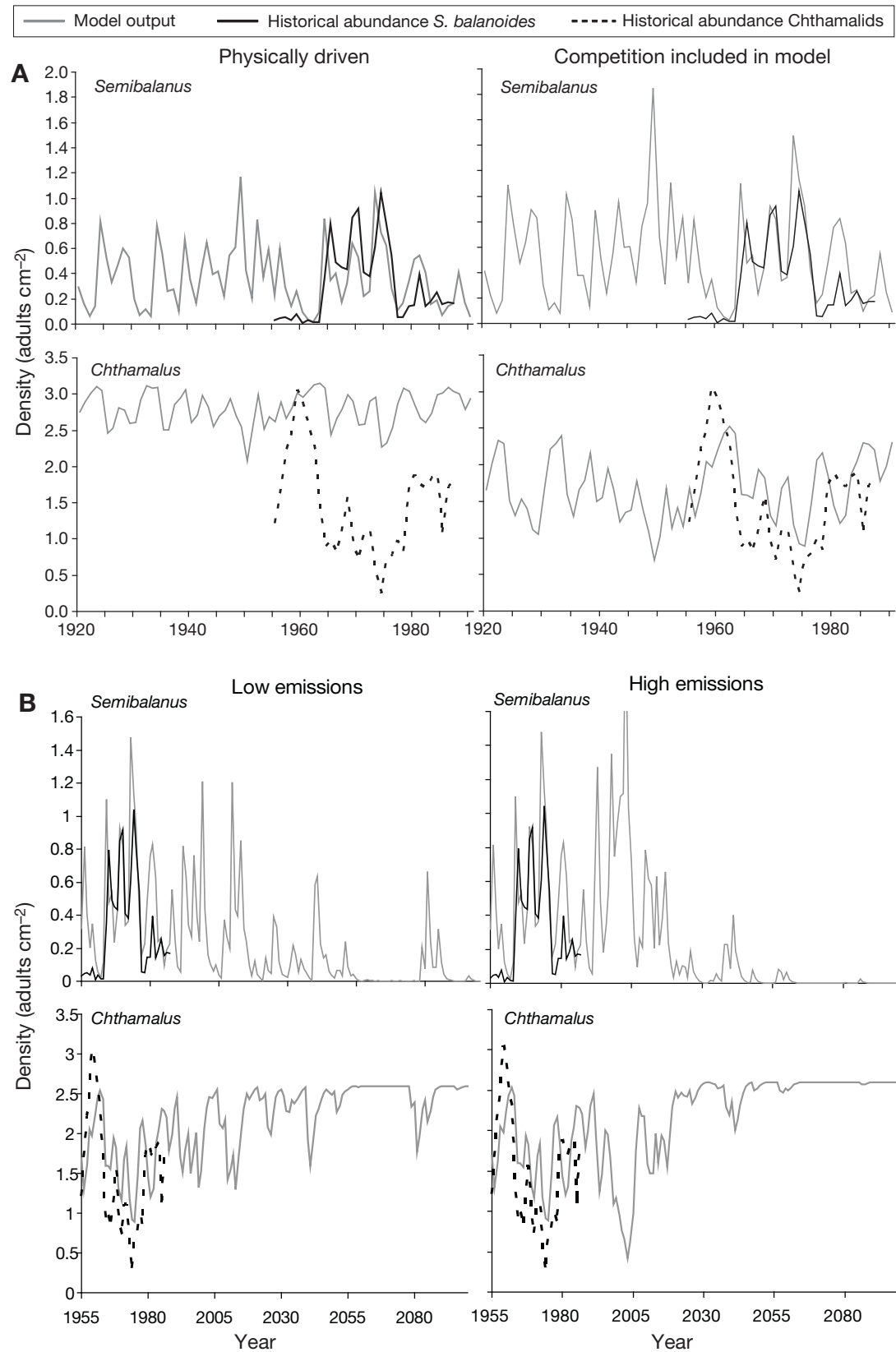

Fig. 2. (A) Models simulating densities of the northern species *Semibalanus balanoides* and southern species of *Chthamalus* with and without competition. These are compared against Southward's time series (B). Using the competition-based model which fitted best, simulations of the future under high and low emissions scenarios are shown (after Poloczanska et al. 2008)

The frequency of occurrence of shores with different categories of algal abundance was then related to wave exposure and winter minimum SST. Forecasts of the future abundance of canopy-forming fucoid algae could then be made using different scenarios of increasing temperature and wave action (i.e. UKCIP, Hulme et al. 2002, IPCC 2007).

Fig. 3 illustrates how the major canopy-forming algae, *Ascophyllum nodosum*, is forecast to respond to increasing temperatures and wave exposure driven by increasing wind speed. This approach has been extended to a suite of other canopy-forming fucoids. Table 2 shows the proportion of sites where *Ascophyllum* and others would be 'abundant' (>30% cover) on the Crisp & Southward (1958) abundance scale (the other categories are common, frequent, occasional, rare and not found). *Fucus serratus* is remarkably resilient, reflecting its ability to occur at moderately exposed to exposed sites low on the shore. *F. serratus* canopies reduce diversity of understory algae and invertebrates due to their sweeping action (Hawkins & Harkin 1985, Jenkins et al. 1999b), including markedly reducing recruitment of barnacles (Hawkins 1983, Jenkins et al. 1999c). *Ascophyllum* would appear to be surprisingly resilient, perhaps due to gradients in morphology, with stunted short plants being able to persist in surprisingly exposed conditions once established. This is despite the known susceptibility of its germlings to wave action (Miller & Vadas 1984). *F. vesiculosus* would be resilient to small changes, but exhibits a sharp threshold with further increases in wave action. *Pelvetia* would also be expected to decrease by over 10% with modest increases in wave action. *F. spiralis* appears most vulnerable, with a reduction greater than 20%. High shore

Fucus canopies are known to facilitate settling barnacles and protect high shore sub-canopy algae (Hawkins 1983, Leonard 2000, Ingolfsson & Hawkins 2008). *Ascophyllum* also facilitates a diverse algal understory which rapidly dies once the canopy is removed (Jenkins et al. 1999a). Patches of *F. vesiculosus* provide a refuge for a diverse assemblage of invertebrates and algae (Thompson et al. 1996) which would diminish if cover contracted. There are strong gradients of sea temperature across the British Isles that can fall as low as 6°C in the enclosed Irish Sea and continentally influenced southern North Sea. Thus we forecast that temperature rises along with increased wave action will act together to reduce fucoid canopy cover.

The balance between fucoid algae and suspension feeding barnacles has long been known to be modulated by limpet grazing (Southward 1964). Proliferation of algae occurs on more exposed shores when limpets are experimentally removed (Jones 1948, Hawkins 1981, Jenkins et al. 2005, Coleman et al. 2006) or killed by oil spills and their clean up (Southward & Southward 1978). Algal growth is also high during early successional stages after placement of new structures in the sea (Hawkins et al. 1983, Moschella et al. 2005). Recent work has also shown that *Ascophyllum* is vulnerable to limpet grazing (Davies et al. 2008), perhaps due to milder winters encouraging limpet recruitment coupled with increased wave action. Further south in Europe (Brittany), more anecdotal observations suggest *Ascophyllum* is being reduced due to limpet grazing (Lorenzen 2007, S. J. Hawkins & N. Mieszkowska pers. obs.). Such biological interactions will further compound the effects of rising temperatures and increased wave action. Subtle behavioural and facilitative effects

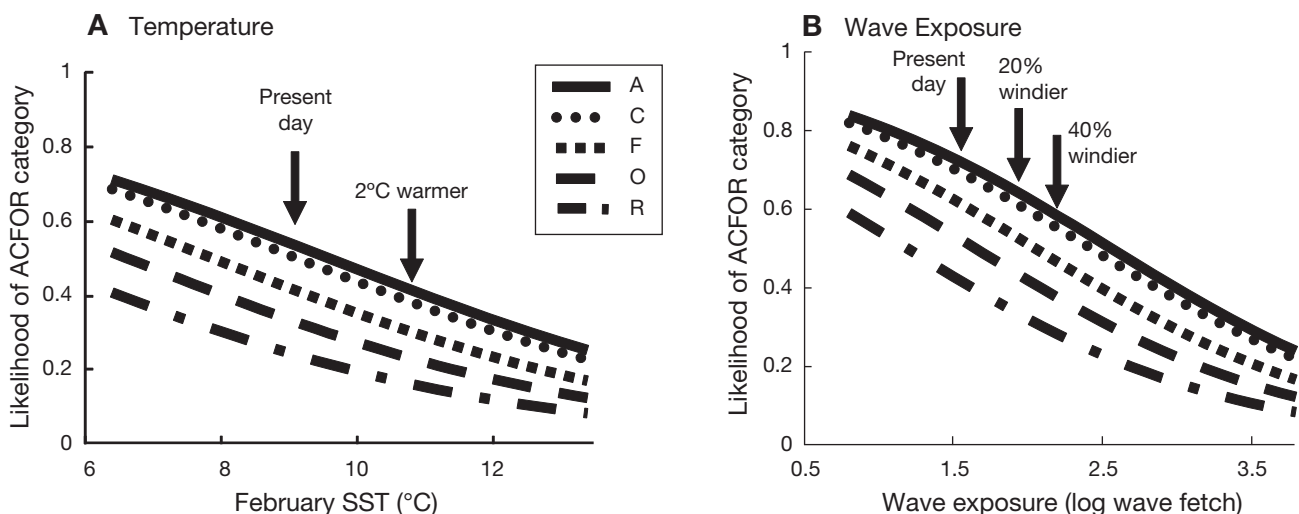

Fig. 3. *Ascophyllum nodosum*. Outputs of multinomial logistic regression modelling of present day distributions versus winter sea surface temperatures (SST; February) and wave fetch; a climate envelope model for *Ascophyllum nodosum*. The predicted shifts along the ACFOR category (Abundant, Common, Frequent, Occasional and Rare) with (A) increased SST of 2°C and (B) wind speeds of 120 and 140% are highlighted showing subsequent decreases in this key species

Table 2. Expected percentage loss of MarClim sites where listed species are presently Abundant (>30% cover) on the Crisp & Southward (1958) scale with 20 and 40% windier conditions

Species	Increase in wind speed (%)	
	20	40
<i>Ascophyllum nodosum</i>	6	11
<i>Fucus serratus</i>	No change	No change
<i>Fucus spiralis</i>	21	32
<i>Fucus vesiculosus</i>	8	20
<i>Pelvetia canaliculata</i>	11	18

may also occur. *Patella vulgata* aggregates under *Fucus* clumps and dies or migrates when fucoid clumps are removed (Hartnoll & Hawkins 1985, Moore et al. 2007a, Hawkins et al. 2008). This effect becomes more pronounced with increasing numbers of *P. depressa*, a southern species of limpet that does not aggregate under *Fucus* (Moore et al. 2007a). The consequences of *P. vulgata* aggregation behaviour have been modelled and greater cover of fucoids persists when aggregation occurs (Burrows & Hawkins 1998, Johnson et al. 1998). This, along with changes in species composition of dominant limpet grazers, has the potential to influence both the dynamics and structure of shores with fucoid and barnacle mosaics (Leonard 2000).

OVERVIEW AND DISCUSSION

Mechanisms driving change

At range edges there are ecological limits on the ability of adults to survive and reproduce, and of propagules and larvae to reach suitable sites for successful recruitment (Hutchins 1947). Range extensions are ultimately driven by increased abundance and reproductive success of populations within the range, which provide the propagules for consistent and successful recruitment at the range edges. This pattern has been recently demonstrated following the range extension of the sea urchin *Centrostephanus rodgersii* in Australia (Ling et al. 2008, 2009). Physical barriers to larval dispersal may be a proximate factor setting a particular limit (Gaines et al. 2007); however, new populations at range limits also need to establish sufficient numbers to overcome low density Allee effects, and thus become self-sustaining and/or inter-connected within a meta-population network (Hughes et al. 1997). Range contractions occur when species chronically fail to recruit or due to occasional extreme events, such as the 1962–1963 cold winter in northern Europe (Crisp 1964), or warm events such as have recently occurred in the Mediterranean (Coma et al. 2009) and the Pacific coast of North America (Harley et al. 2006). Clearly,

recruitment processes are ultimately responsible for range expansions in sessile marine species, but recruitment fluctuations are also important in determining the intensity of interactions within an assemblage of species and hence community structure.

The importance of recruitment driving change is clearly illustrated by population data for *Osilinus lineatus* (Mieszkowska et al. 2007). The range of this species retracted in North Wales from Anglesey to the south side of the Llyn Peninsula in 1962–1963, following the extremely cold winter. Subsequent recovery and recolonisation of sites was hindered by 25 yr of predominantly colder weather. In recent years, *O. lineatus* has breached the barrier of the Llyn and is now abundant on Anglesey, with odd individuals recruiting beyond the Great Orme ~52 km beyond previous records. In addition, range extensions of 2 chthamalid species have occurred in the Irish Sea. *Chthamalus stellatus* has extended ~77 km from the nearest populations in North Wales to the Isle of Man, and *C. montagui* has extensively colonised artificial structures and natural rock along the North Wales coast as far as the Wirral where only a single individual had been recorded in the 1950s by A. J. Southward (129 km, S. J. Hawkins pers. obs.). The range of *C. montagui* has also extended down the east coast of Scotland ~156 km from Aberdeen to Fife (M. T. Burrows pers. obs.). In contrast to the case in the North Sea and Irish Sea, both chthamalid species have failed to penetrate beyond the Isle of Wight, despite effective reproduction right up to the range edges (Herbert et al. 2007, 2009).

Our work, and that by other authors, demonstrates that responses are species- and habitat-specific (e.g. Lima et al. 2007a, Jones et al. 2009, Pearson et al. 2009). Together, this body of work suggests that the likelihood of range extensions will be determined by a combination of life history traits including reproductive mode, fecundity, larval behaviour and larval duration, all of which have the potential to influence dispersal capability (Gaines et al. 2007). Thus it seems unlikely that whole assemblages will shift simultaneously, in contrast to plankton in very open pelagic systems (Beaugrand et al. 2001). Interestingly, the greatest advances have been made by species such as *Gibbula umbilicalis* with a short larval life history stage (<3 d) and generalist habitat requirements (Mieszkowska et al. 2006). This species appears to have made repeated small advances to consolidate along the south coast of England, perhaps aided by artificial habitat provided by sea defences.

Southern advancers, northern persisters?

Meta-analyses of a variety of marine and terrestrial taxa have shown that more species are advancing

polewards than are retreating (Parmesan 1996, Parmesan & Yohe 2003). Studies of intertidal species in Portugal (Lima et al. 2007a) and the British Isles (summarized in Mieszkowska et al. 2005, Helmuth et al. 2006) reveal a similar pattern. This could just be an artefact of there being more southern species available to advance from a greater diversity of clades. There may, however, be a mechanistic explanation. Where warm-temperate and cold-temperate intertidal species coexist, it is likely that the colder water taxon may be competitively superior in terms of growth rates and maximum body size. This is certainly the case for barnacles and limpets. The boreal *Semibalanus balanoides* clearly grows faster and outcompetes Lusitanian chthamalids (Southward & Crisp 1954b, Connell 1961, Herbert et al. 2007, Poloczanska et al. 2008, Herbert et al. 2009), while *Patella vulgata* grows faster and outperforms *P. depressa* (Boaventura et al. 2002, Moore et al. 2007b). It has been known since Thorson (1950) that many cold-temperate and boreal species are single brooders/spawners with reproduction linked to spring blooms (e.g. *S. balanoides*) or the secondary autumn peak in production (e.g. *P. vulgata*). This can lead to boom or bust recruitment with occasional massive recruitment events (Connell 1961, Connell et al. 1984, Kendall et al. 1985, Hansson et al. 2003). In contrast, southern species are often multiple brooders/spawners (Burrows et al. 1992) with more trickle-like recruitment. Hot weather probably releases them from competition with colder water species (Poloczanska et al. 2008). A combination of greater competitive ability and occasional massive recruitment events may explain why northern species can still persist. However, several years of poor recruitment would be likely to lead to rapid non-linear decline of northern species (Svensson et al. 2006), unless there are refuges such as estuaries from which they can recolonise.

Implications for biodiversity and ecosystem functioning

Warmer temperatures with associated desiccation stress will reduce recruitment of fucoids by directly influencing survival, but also indirectly by suppressing growth and reducing the likelihood of escapes from grazing (Hawkins 1981, Thompson et al. 2004). Escapes of fucoids are more likely on dense barnacle cover (Hawkins 1981). Thus switches from *Semibalanus balanoides* to smaller chthamalids reduce the probability of escapes occurring which could scale up from patches to whole shores (Jenkins et al. 2005). Increases in gastropod diversity will also increase the diversity of grazing methods that are employed with habitat patches (Hawkins et al. 1989), combining to

increase mortality of germlings (O'Connor & Crowe 2005). Increased numbers of mid- to high shore *Osili- nus lineatus* (Mieszkowska et al. 2007) are likely to impact both *Fucus spiralis* and *Pelvetia canaliculata* at their lower limits, adding to mortality at their upper limit due to an increased frequency of extreme hot weather events (see Schonbeck & Norton 1978, Hawkins & Hartnoll 1985). *P. canaliculata* and *F. spiralis* are at risk from localised extinction events at hot spots (Helmuth et al. 2006), which may eventually scale up to whole sections of coastline.

As juvenile and adult fucoid mortality will increase due to both grazing and with wave action, exposed shorelines become characterised by a lower density of adult plants (Jonsson et al. 2006). Therefore, rougher seas and more frequent extreme events (Hulme et al. 2002), and greater grazer diversity as additional species are added, would be likely to reduce biomass and production of canopy-forming macroalgae. There could be a shift along wave exposure gradients leading to fewer areas dominated by large primary producers relative to those dominated by secondary producers, as currently occurs in southern Europe (Coleman et al. 2006). Additionally, it seems likely that fast-growing *Semibalanus balanoides* will be replaced by slower growing chthamalid barnacles, lowering secondary productivity of filter feeders. With fewer canopy species there would be less export of algal detritus from the system: many shores may become net importers of production from nearshore planktonic communities (Fig. 4, based on Hawkins et al. 1992).

The British Isles and Ireland are largely surrounded by shallow water, and major upwelling does not occur, in contrast to further south in Europe off the Portuguese and Spanish coasts and elsewhere in the world. Thus differences caused by changes in upwelling and recruitment regimes (e.g. Lima et al. 2006, Menge et al. 2009) are unlikely to occur around the British Isles, although regional-scale differences can occur due to differences in run-off and embayment influencing both nutrient status and larval retention (Burrows et al. 2009).

Higher biodiversity, lower production?

The general ecological literature abounds with studies exploring the links between biodiversity, ecological processes and ecosystem functioning (O'Connor & Crowe 2005, Bremner 2008, Griffin et al. 2008, 2009, Maggi et al. 2009). Many single trophic level studies have shown a positive relationship between assemblage diversity, usually quantified as species richness, and production using biomass as a proxy (e.g. Hector et al. 1999). Together, our forecast-based statistical modelling and comparisons with lower latitudes in

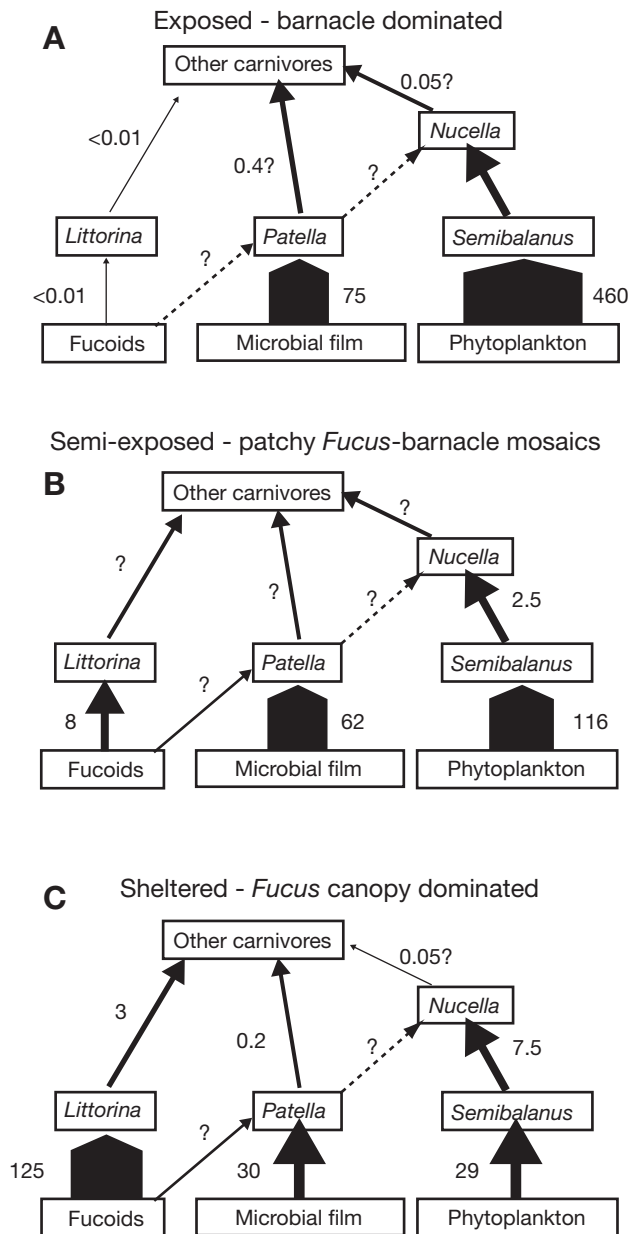

Fig. 4. Major flows of energy ($\text{gC m}^{-2} \text{yr}^{-1}$) on (A) exposed, barnacle-dominated shores; (B) semi-exposed, patchy *Fucus*-barnacle mosaic shores; and (C) sheltered, *Fucus* canopy-dominated shores on the Isle of Man, UK, typical of northern Britain where *Semibalanus* is the dominant mid-shore barnacle (adapted from Hawkins et al. 1992, Raffaelli & Hawkins 1999). Arrow width indicates relative size of energy flow. Dotted arrows indicate interactions needing further clarification. (?) Value unknown or uncertain

Europe indicates that grazer diversity is likely to increase whilst production of canopy-forming algae is expected to decrease. This pattern does not match emerging theory; there are, however, good explanations for this apparent paradox. Different processes are occurring at different trophic levels that are ultimately

driven by underlying physical forcing which biological processes modify. Warming and increased wave action are likely to favour grazing gastropods, many of which are from southern clades and are more diverse and abundant in southern Europe (Ballantine 1961, Lewis 1964, Hawkins & Hartnoll 1983, Hawkins et al. 1992, Southward et al. 1995). Even across the British Isles, grazer diversity is much less in north Britain than the southwest (Southward et al. 1995). Grazing limpets also predominate numerically on more exposed shores in Europe (Lewis 1964, Coleman et al. 2006, Burrows et al. 2009). Cooler, more sheltered conditions favour fucooids, a northern clade. Grazers prevent establishment of fucooids, but wave action primarily acts on persistence of adult plants (Jonsson et al. 2006), although adult plants can also be consumed (Davies et al. 2007). Increased grazer diversity would be expected to reduce the probability of fucooid algae escapes given the greater range of feeding mechanisms involved in a more diverse grazer guild (Hawkins et al. 1989). Warmer, drier weather is also likely to reduce fucooid recruitment and early survival (Thompson et al. 2004). There may be changes in productivity in microbial films with different diversity of grazers, but this remains unexplored to date and such production is likely to be much less than that of macroalgae (Hawkins et al. 1992). Theoretically driven studies of the relationship between biodiversity and ecosystem functioning are now beginning to address multitrophic interactions, but this work is in its infancy (e.g. O'Connor & Crowe 2005, Bremner 2008, Griffin et al. 2008). More work is needed on early stage survival of algae and interactions with a variety of grazers (but see Kordas & Dudgeon 2009). A combination of long-term observations with experiments and modelling should unravel these complex processes to turn forecasts into more precise predictions of future states of ecosystems, their structure and ultimately their functioning.

CONCLUSIONS

Rapid changes are occurring in the distribution patterns of rocky intertidal species on a European scale. Rocky shore species can serve as cost-effective sentinels for changes in nearshore ecosystems, such as in plankton and fish (Southward 1980, Southward et al. 1995, 2005). Key organisms, such as gastropod grazers, space-occupying barnacles and canopy-forming algae, make useful study taxa for predictive modelling due to experimentally derived knowledge of ecological processes that generate spatial and temporal changes in abundance. In a warming climate, the balance between grazers/suspension feeders and fucooids is likely to alter. With the probability of algal escapes from

grazing being lower, there will be increased interactions between environmentally induced stress and increased grazing pressure on early stages of multiple species (Jenkins et al. 2005, Coleman et al. 2006). There will be less shelter from canopy-forming species due to changes in identity and increasing diversity within the grazing guild, leading to lower biodiversity and productivity with reduced export of detritus.

Acknowledgements. S.J.H., P.J.M., M.T.B., E.P. and N.M. were funded by the MarClim consortium (www.mba.ac.uk/marclim); Countryside Council for Wales, The Crown Estate, Department for Environment and Rural Affairs, English Nature, Environment Agency, Joint Nature Conservation Committee, Scottish Executive, Scottish Natural Heritage, States of Jersey and the Worldwide Wildlife Foundation). S.J.H. was also supported by NERC via a grant-in-aid funded fellowship and the Oceans 2025 programme. S.J.H. and P.J.M. were also supported by NERC urgency grant no. NE/E000029/1 and S.J.H. and S.R.J. were supported by NERC small grant no. NE/E010482/1. M.J.G. was supported by a Great Western Research Fellowship. We thank all those who assisted with the fieldwork. H.E.S., S.J.H., N.M. and S.R.J. received support from the MarBEF consortium. The late A. J. Southward contributed much to this work right up until he passed away. We owe much to his pioneering efforts and dogged continuation of decadal time series.

LITERATURE CITED

- Airoldi L, Beck MW (2007) Loss, status and trends for coastal marine habitats of Europe. *Oceanogr Mar Biol Annu Rev* 45:345–405
- Airoldi L, Abbiati M, Beck MW, Hawkins SJ and others (2005) An ecological perspective on the deployment and design of low-crested and other hard coastal defence structures. *Coast Eng* 52:1073–1087
- Ardre F (1971) Contribution a l'etude des algues marines du Portugal. II. *Ecologie et Chorologie. Bull Cent Etud Rech Sci Biarritz* 8:359–574
- Ballantine WJ (1961) A biologically defined exposure scale for the comparative description of rocky shores. *Field Stud* 1:1–19
- Balvanera P, Pfisterer AB, Buchmann N, He JS, Nakashizuka T, Raffaelli D, Schmid B (2006) Quantifying the evidence for biodiversity effects on ecosystem functioning and services. *Ecol Lett* 9:1146–1156
- Beare D, Burns F, Jones E, Peach K and others (2004) An increase in the abundance of anchovies and sardines in the north-western North Sea since 1995. *Glob Change Biol* 10:1209–1213
- Beaugrand G, Reid PC (2003) Long-term changes in phytoplankton, zooplankton and salmon related to climate. *Glob Change Biol* 9:801–817
- Beaugrand G, Ibañez F, Lindley JA (2001) Geographical distribution and seasonal and diel changes in the diversity of calanoid copepods in the North Atlantic and North Sea. *Mar Ecol Prog Ser* 219:189–203
- Beaugrand G, Reid PC, Ibanez F, Lindley JA, Edwards M (2002) Reorganization of North Atlantic marine copepod biodiversity and climate. *Science* 296:1692–1694
- Bindoff NL, Willebrand J, Artale V, Cazenave A and others (2007) Observations: oceanic climate change and sea level. In: Solomon S, Qin D, Manning M, Chen Z and others (eds) *Climate change 2007: the physical science basis. Contribution of Working Group 1 to the Fourth Assessment Report of the Intergovernmental Panel on Climate Change*. Cambridge University Press, Cambridge
- Blight AJ, Thompson RC (2008) Epibiont species richness varies between holdfasts of a northern and a southerly distributed kelp species. *J Mar Biol Assoc UK* 88:469–475
- Boaventura D, da Fonseca LC, Hawkins SJ (2002) Analysis of competitive interactions between the limpets *Patella depressa* Pennant and *Patella vulgata* L. on the northern coast of Portugal. *J Exp Mar Biol Ecol* 271:171–188
- Bremner J (2008) Species' traits and ecological functioning in marine conservation and management. *J Exp Mar Biol Ecol* 366:37–47
- Burcharth HF, Hawkins SJ, Zanuttigh B, Lamberti A (2007) *Environmental design guidelines for low crested coastal structures*. Elsevier, Oxford
- Burrows MT, Hawkins SJ (1998) Modelling patch dynamics on rocky shores using deterministic cellular automata. *Mar Ecol Prog Ser* 167:1–13
- Burrows MT, Hawkins SJ, Southward AJ (1992) A comparison of reproduction in co-occurring chthamalid barnacles, *Chthamalus stellatus* (Poli) and *Chthamalus montagui* Southward. *J Exp Mar Biol Ecol* 160:229–249
- Burrows MT, Harvey R, Robb L (2008) Wave exposure indices from digital coastlines and the prediction of rocky shore community structure. *Mar Ecol Prog Ser* 353:1–12
- Burrows MT, Harvey R, Robb L, Poloczanska ES and others (2009) Spatial scales of variance in abundance of intertidal species: effects of region, dispersal mode, and trophic level. *Ecology* 90:1242–1254
- Coleman RA, Underwood AJ, Benedetti-Cecchi L, Åberg P and others (2006) A continental scale evaluation of the role of limpet grazing on rocky shores. *Oecologia* 147:556–564
- Coma R, Ribes M, Serrano E, Jimenez E, Salat J, Pascual J (2009) Global warming-enhanced stratification and mass mortality events in the Mediterranean. *Proc Natl Acad Sci USA* 106:6176–6181
- Connell JH (1961) The influence of interspecific competition and other factors on the distribution of the barnacle *Chthamalus stellatus*. *Ecology* 42:710–723
- Connell JH, Tracey JG, Webb LJ (1984) Compensatory recruitment, growth, and mortality as factors maintaining rain forest tree diversity. *Ecol Monogr* 54:141–164
- Crisp DJ (1964) The effects of the severe winter of 1962–63 on marine life in Britain. *J Anim Ecol* 33:179–210
- Crisp DJ, Southward AJ (1958) The distribution of intertidal organisms along the coasts of the English Channel. *J Mar Biol Assoc UK* 37:157–208
- Crisp DJ, Southward AJ, Southward EC (1981) On the distribution of the intertidal barnacles *Chthamalus stellatus*, *Chthamalus montagui* and *Euraphia depressa*. *J Mar Biol Assoc UK* 61:359–380
- Davies AJ, Johnson MP, Maggs CA (2007) Limpet grazing and loss of *Ascophyllum nodosum* on decadal time scales. *Mar Ecol Prog Ser* 339:131–141
- Davies AJ, Johnson MP, Maggs CA (2008) Subsidy by *Ascophyllum nodosum* increases growth rate and survivorship of *Patella vulgata*. *Mar Ecol Prog Ser* 366:43–48
- Dayton P, Curran S, Kitchingman A, Wilson M and others (2005) Coastal systems. In: Hassan R, Scholes R, Ash N (eds) *Ecosystems and human well-being: current state and trends, Vol I*. Island Press, Washington, DC, p 513–550
- Dulvy NK, Jennings S, Rogers SI, Maxwell DL (2006) Threat and decline in fishes: an indicator of marine biodiversity. *Can J Fish Aquat Sci* 63:1267–1275
- Edwards M, Richardson AJ (2004) Impact of climate change on marine pelagic phenology and trophic mismatch.

- Nature 430:881–884
- Emmerson MC, Solan M, Emes C, Paterson DM, Raffaelli D (2001) Consistent patterns and the idiosyncratic effects of biodiversity in marine ecosystems. *Nature* 411:73–77
- Fischer-Piette E (1936) Etudes sur la biogeographie intercotidale des deux rives de la Manche. *J Linn Soc Lond Zool* 40:181–272
- Fischer-Piette E (1955) Repartition, le long des cotes septentrionales de l'Espagne, des principales especes peuplant les rochers intercotidaux. *Ann Inst Ocenaogr Monaco* 31: 37–124
- Forbes E (1858) The distribution of marine life, illustrated chiefly by fishes and molluscs and radiata. In: Johnston AK (ed) *AK Johnston's physical atlas*. W & AK Johnston, Edinburgh, p 99–101
- Gaines SD, Gaylord B, Gerber LR, Hastings A, Kinlan BP (2007) Connecting places: the ecological consequences of dispersal in the sea. *Oceanography* 20:90–99
- Genner MJ, Sims DW, Wearmouth VJ, Southall EJ, Southward AJ, Henderson PA, Hawkins SJ (2004) Regional climatic warming drives long-term community changes of British marine fish. *Proc R Soc Lond B Biol Sci* 271: 655–661
- Gray JS (1997) Marine biodiversity: patterns, threats and conservation needs. *Biodivers Conserv* 6:153–175
- Griffin JN, de la Haye KL, Hawkins SJ, Thompson RC, Jenkins SR (2008) Predator diversity and ecosystem functioning: density modifies the effect of resource partitioning. *Ecology* 89:298–305
- Griffin JN, Mendez V, Johnson AF, Jenkins SR, Foggo A (2009) Functional diversity predicts overyielding effect of species combination on primary productivity. *Oikos* 118: 37–44
- Hansson LJ, Hudson IR, Seddon RJ, Shaw O, Thomason JC (2003) Massive recruitment of the barnacle *Semibalanus balanoides* in the Clyde Sea (Scotland, UK) in the spring of 2000. *J Mar Biol Assoc UK* 83:923–924
- Harley CDG (2008) Tidal dynamics, topographic orientation, and temperature-mediated mass mortalities on rocky shores. *Mar Ecol Prog Ser* 371:37–46
- Harley CDG, Hughes AR, Hultgren KM, Miner BG and others (2006) The impacts of climate change in coastal marine systems. *Ecol Lett* 9:228–241
- Hartnoll RG, Hawkins SJ (1985) Patchiness and fluctuations on moderately exposed rocky shores. *Ophelia* 24:53–64
- Hawkins SJ (1981) The influence of season and barnacles on algal colonization of *Patella vulgata* (L.) exclusion areas. *J Mar Biol Assoc UK* 61:1–15
- Hawkins SJ (1983) Interaction of *Patella* and macroalgae with settling *Semibalanus balanoides* (L.). *J Exp Mar Biol Ecol* 71:55–72
- Hawkins SJ, Harkin E (1985) Preliminary canopy removal in algal dominated communities low on the shore and in the shallow subtidal. *Bot Mar* 28:223–230
- Hawkins SJ, Hartnoll RG (1983) Grazing of intertidal algae by marine invertebrates. *Oceanogr Mar Biol Annu Rev* 21: 195–282
- Hawkins SJ, Hartnoll RG (1985) Factors determining the upper limits of intertidal canopy-forming algae. *Mar Ecol Prog Ser* 20:265–271
- Hawkins SJ, Southward AJ, Barrett RL (1983) Population structure of *Patella vulgata* during succession on rocky shores in south-west England. *Oceanol Acta Special Volume*:103–107
- Hawkins SJ, Watson DC, Hill AS, Harding SP, Kyriakides MA, Hutchinson S, Norton TA (1989) A comparison of feeding mechanisms in microphagus, herbivorous, intertidal, prosobranchs in relation to resource partitioning. *J Molluscan Stud* 55:151–165
- Hawkins SJ, Hartnoll RG, Kain JM, Norton TA (1992) Plant–animal interactions on hard substrata in northeast Atlantic. In: John DM, Hawkins SJ, Price JH (eds) *Plant–animal interactions in the marine benthos*. Oxford University Press, Oxford, p 1–32
- Hawkins SJ, Southward AJ, Genner MJ (2003) Detection of environmental change in a marine ecosystem: evidence from the western English Channel. *Sci Total Environ* 310: 245–256
- Hawkins SJ, Moore PJ, Burrows MT, Poloczanska E and others (2008) Complex interactions in a rapidly changing world: responses of rocky shore communities to recent climate change. *Clim Res* 37:123–133
- Hector A, Schmid B, Beierkuhnlein C, Caldeira MC and others (1999) Plant diversity and productivity experiments in European grasslands. *Science* 286:1123–1127
- Helmuth B, Mieszkowska N, Moore P, Hawkins SJ (2006) Living on the edge of two changing worlds: forecasting responses of rocky intertidal ecosystems to climate change. *Annu Rev Ecol Evol Syst* 37:373–404
- Herbert RJ, Hawkins SJ, Shearer M, Southward AJ (2003) Range extension and reproduction of the barnacle *Balanus perforatus* in the eastern English channel. *J Mar Biol Assoc UK* 83:73–82
- Herbert RJH, Southward AJ, Shearer M, Hawkins SJ (2007) Influence of recruitment and temperature on distribution of intertidal barnacles in the English Channel. *J Mar Biol Assoc UK* 87:487–499
- Herbert RJH, Southward AJ, Clarke RT, Shearer M, Hawkins SJ (2009) Persistent border: an analysis of the geographic boundary of an intertidal species. *Mar Ecol Prog Ser* 379: 135–150
- Hiscock K, Southward AJ, Tittley I, Hawkins SJ (2004) Effects of changing temperature on benthic marine life in Britain and Ireland. *Aquat Conserv* 14:333–362
- Hooper DU, Chapin FS, Ewel JJ, Hector A and others (2005) Effects of biodiversity on ecosystem functioning: a consensus of current knowledge. *Ecol Monogr* 75:3–35
- Hughes JB, Daily GC, Ehrlich PR (1997) Population diversity: its extent and extinction. *Science* 278:689–692
- Hulme M, Jenkins GJ, Lu X, Turnpenny JR and others (2002) Climate change scenarios for the United Kingdom: the UKCIP02 scientific report. Tyndall Centre for Climate Change Research, School of Environmental Sciences, University of East Anglia, Norwich
- Hutchins LW (1947) The basis for temperature zonation in geographical distribution. *Ecol Monogr* 17:325–335
- Hyder K, Aberg P, Johnson MP, Hawkins SJ (2001) Models of open populations with space limited recruitment: extension of theory and application to the barnacle *Chthamalus montagui*. *J Anim Ecol* 70:853–863
- Ingolfsson A, Hawkins SJ (2008) Slow recovery from disturbance: a 20 year study of *Ascophyllum* canopy clearances. *J Mar Biol Assoc UK* 88:689–691
- IPCC (2007) Climate change 2007: the physical science basis. Contribution of Working Group I to the Fourth Assessment Report of the Intergovernmental Panel on Climate Change. Cambridge University Press, Cambridge
- Jenkins SR, Hawkins SJ, Norton TA (1999a) Direct and indirect effects of a macroalgal canopy and limpet grazing in structuring a sheltered intertidal community. *Mar Ecol Prog Ser* 188:81–92
- Jenkins SR, Hawkins SJ, Norton T (1999b) Interaction between a fucoid canopy and limpet grazing in structuring a low shore intertidal community. *J Exp Mar Biol Ecol* 233:41–63
- Jenkins SR, Norton T, Hawkins SJ (1999c) Settlement and

- post-settlement interactions between *Semibalanus balanoides* (L.) (Crustacea: Cirripedia) and three species of fucoid canopy algae. *J Exp Mar Biol Ecol* 236:49–67
- Jenkins SR, Aberg P, Cervin G, Coleman RA and others (2000) Spatial and temporal variation in settlement and recruitment of the intertidal barnacle *Semibalanus balanoides* (L.) (Crustacea: Cirripedia) over a European scale. *J Exp Mar Biol Ecol* 243:209–225
- Jenkins SR, Coleman RA, Della Santina P, Hawkins SJ, Burrows MT, Hartnoll RG (2005) Regional scale differences in the determinism of grazing effects in the rocky intertidal. *Mar Ecol Prog Ser* 287:77–86
- Johnson MP, Hughes RN, Burrows MT, Hawkins SJ (1998) Beyond the predation halo: small scale gradients in barnacle populations affected by the relative refuge value of crevices. *J Exp Mar Biol Ecol* 231:163–170
- Jones NS (1948) Observations and experiments on the biology of *Patella vulgata* at Port St. Mary, Isle of Man. *Proc Trans Liverpool Biol Soc* 56:60–77
- Jones SJ, Mieszkowska N, Wethey DS (2009) Linking thermal tolerances and biogeography: *Mytilus edulis* (L.) at its southern limit on the east coast of the United States. *Biol Bull* 217:73–85
- Jonsson PR, Granhag L, Moschella PS, Aberg P, Hawkins SJ, Thompson RC (2006) Interactions between wave action and grazing control: the distribution of intertidal macroalgae. *Ecology* 87:1169–1178
- Kaiser MJ, Graham N, Rose CS, Wiebe PH (2007) Ecosystem-sensitive approaches to fishing: reconciling fisheries with conservation through improvements in fishing technology. *ICES J Mar Sci* 64:1610–1611
- Kendall MA, Bowman RS, Williamson P, Lewis JR (1985) Annual variation in the recruitment of *Semibalanus balanoides* on the north Yorkshire coast 1969–1981. *J Mar Biol Assoc UK* 65:1009–1030
- Kendall MA, Williamson P, Garwood PR (1987) Annual variation in recruitment and population structure of *Monodonta lineata* and *Gibbula umbilicalis* populations at Aberaeron, mid-Wales. *Estuar Coast Shelf Sci* 24:499–511
- Kendall MA, Burrows MT, Southward AJ, Hawkins SJ (2004) Predicting the effects of marine climate change on the invertebrate prey of the birds of rocky shores. *Ibis* 146: 40–47
- Kordas RL, Dudgeon S (2009) Modeling variation in interaction strength between barnacles and fucoids. *Oecologia* 158:717–731
- Leonard GH (2000) Latitudinal variation in species interactions: a test in the New England rocky intertidal zone. *Ecology* 81:1015–1030
- Lewis JR (1964) *The ecology of rocky shores*. Hodder & Stoughton, London
- Lima FP, Queiroz N, Ribeiro PA, Hawkins SJ, Santos AM (2006) Recent changes in the distribution of a marine gastropod, *Patella rustica* Linnaeus, 1758, and their relationship to unusual climatic events. *J Biogeogr* 33:812–822
- Lima FP, Ribeiro PA, Queiroz N, Hawkins SJ, Santos AM (2007a) Do distributional shifts of northern and southern species of algae match the warming pattern? *Glob Change Biol* 13:2592–2604
- Lima FP, Ribeiro PA, Queiroz N, Xavier R, Tarroso P, Hawkins SJ, Santos AM (2007b) Modelling past and present geographical distribution of the marine gastropod *Patella rustica* as a tool for exploring responses to environmental change. *Glob Change Biol* 13:2065–2077
- Ling SD (2008) Range expansion of a habitat-modifying species leads to a loss of taxonomic diversity: a new and impoverished reef state. *Oecologia* 156:883–894
- Ling SD, Johnson CR, Frusher S, King CK (2008) Reproductive potential of a marine ecosystem engineer at the edge of a newly expanded range. *Glob Change Biol* 14:907–915
- Ling SD, Johnson CR, Ridgeway K, Hobday AJ, Haddon M (2009) Climate-driven range extension of a sea urchin: inferring future trends by analysis of recent population dynamics. *Glob Change Biol* 15:719–731
- Loreau M, Naeem S, Inchausti P (2002) *Biodiversity and ecosystem functioning: synthesis and perspectives*. Oxford University Press, Oxford
- Lorenzen S (2007) The limpet *Patella vulgata* L. at night in air: effective feeding on *Ascophyllum nodosum* monocultures and stranded seaweeds. *J Molluscan Stud* 73:267–274
- Mackenzie BR, Schiedek D (2007) Daily ocean monitoring since the 1860s shows record warming of northern European seas. *Glob Change Biol* 13:1335–1347
- Maggi E, Bertocci I, Vaselli S, Benedetti-Cecchi L (2009) Effects of changes in number, identity and abundance of habitat-forming species on assemblages of rocky seashores. *Mar Ecol Prog Ser* 381:39–49
- Menge BA, Chan F, Nielsen KJ, Lorenzo ED, Lubchenco J (2009) Climatic variation alters supply-side ecology: impact of climate patterns on phytoplankton and mussel recruitment. *Ecol Monogr* 79:379–395
- Mieszkowska N, Leaper R, Moore P, Kendall MA and others (2005) Assessing and predicting the influence of climate change challenging intertidal rocky shore biota: final report for United Kingdom funders. Report No. 20, Marine Biological Association of the UK, Plymouth
- Mieszkowska N, Kendall MA, Hawkins SJ, Leaper R, Williamson P, Hardman-Mountford NJ, Southward AJ (2006) Changes in the range of some common rocky shore species in Britain: a response to climate change? *Hydrobiologia* 555:241–251
- Mieszkowska N, Hawkins SJ, Burrows MT, Kendall MA (2007) Long-term changes in the geographic distribution and population structures of *Osilinus lineatus* (Gastropoda: Trochidae) in Britain and Ireland. *J Mar Biol Assoc UK* 87:537–545
- Miller SL, Vadas RL (1984) The population biology of *Ascophyllum nodosum*: biological and physical factors affecting survivorship of germlings. *Br Phycol J* 19:198
- Moore HB, Kitching JA (1939) The biology of *Chthamalus stellatus* (Poli). *J Mar Biol Assoc UK* 23:521–541
- Moore P, Hawkins SJ, Thompson RC (2007a) Role of biological habitat amelioration in altering the relative responses of congeneric species to climate change. *Mar Ecol Prog Ser* 334:11–19
- Moore P, Thompson RC, Hawkins SJ (2007b) Effects of grazer identity on the probability of escapes by a canopy-forming macroalga. *J Exp Mar Biol Ecol* 344:170–180
- Moschella PS, Abbiati M, Aberg P, Airoldi L and others (2005) Low-crested coastal defence structures as artificial habitats for marine life: using ecological criteria in design. *Coast Eng* 52:1053–1071
- Naeem S (2006) Expanding scales in biodiversity-based research: challenges and solutions for marine systems. *Mar Ecol Prog Ser* 311:273–283
- Naeem S, Hakansson K, Lawton JH, Crawley MJ, Thompson LJ (1996) Biodiversity and plant productivity in a model assemblage of plant species. *Oikos* 76:259–264
- O'Connor NE, Crowe TP (2005) Biodiversity loss and ecosystems functioning: distinguishing between number and identity of species. *Ecology* 86:1783–1796
- Parmesan C (1996) Climate and species' range. *Nature* 382: 765–766
- Parmesan C (2006) Ecological and evolutionary responses to recent climate change. *Annu Rev Ecol Evol Syst* 37: 637–669

- Parmesan C (2007) Influences of species, latitudes and methodologies on estimates of phenological response to global warming. *Glob Change Biol* 13:1860–1872
- Parmesan C, Yohe G (2003) A globally coherent fingerprint of climate change impacts across natural systems. *Nature* 421:37–42
- Pearson GA, Lago-Leston A, Mota C (2009) Frayed at the edges: selective pressure and adaptive response to abiotic stressors are mismatched in low diversity edge populations. *J Ecol* 97:450–462
- Perry AL, Low PJ, Ellis JR, Reynolds JD (2005) Climate change and distribution shifts in marine fishes. *Science* 308:1912–1915
- Poloczanska E, Babcock RC, Butler A, Hobday A and others (2007) Climate change and Australian marine life. *Oceanogr Mar Biol Annu Rev* 45:407–478
- Poloczanska E, Hawkins SJ, Southward AJ, Burrows MT (2008) Modelling the response of populations of competing species to climate change. *Ecology* 89:3138–3149
- Polunin N (2008) Aquatic ecosystems: trends and global perspectives. Cambridge University Press, Cambridge
- Raffaelli D, Hawkins SJ (1999) Intertidal ecology. Kluwer, London
- Rayner NA, Brohan P, Parker DE, Folland CK and others (2006) Improved analyses of changes and uncertainties in sea surface temperatures measured *in situ* since the mid-nineteenth century: the HadSST2 data set. *J Clim* 19: 446–469
- Roughgarden J, Iwasa Y, Baxter C (1985) Demographic-theory for an open marine population with space-limited recruitment. *Ecology* 66:54–67
- Roughgarden J, Pennington T, Alexander S (1994) Dynamics of the rocky intertidal zone with remarks on generalisation in ecology. *Philos Trans R Soc Lond B Biol Sci* 343:79–85
- Schonbeck M, Norton TA (1978) Factors controlling upper limits of fucoid algae on shore. *J Exp Mar Biol Ecol* 31: 303–313
- Sheppard C (2004) Sea surface temperature 1871–2009 in 14 cells around the United Kingdom. *Mar Pollut Bull* 49: 12–16
- Simkanin C, Powers A, Myers A, McGrath D and others (2005) Using historical data to detect temporal changes in the abundances of intertidal species on Irish shores. *J Mar Biol Assoc UK* 85:1329–1340
- Sims DW, Genner MJ, Southward AJ, Hawkins SJ (2001) Timing of squid migration reflects North Atlantic climate variability. *Proc R Soc Lond B Biol Sci* 268:2607–2611
- Sims DW, Wearmouth VJ, Genner MJ, Southward AJ, Hawkins SJ (2004) Low-temperature-driven early spawning migration of a temperate marine fish. *J Anim Ecol* 73:333–341
- Solan M, Raffaelli DG, Paterson DM, White PCL, Pierce GJ (2006) Introduction. Marine biodiversity and ecosystem function: empirical approaches and future research needs. *Mar Ecol Prog Ser* 311:175–178
- Southward AJ (1964) Limpet grazing and the control of vegetation on rocky shores. In: Crisp DJ (ed) *Grazing in terrestrial and marine environments*. Blackwell, Oxford, p 265–273
- Southward AJ (1967) Recent changes in abundance of intertidal barnacles in south-west England, a possible effect of climatic deterioration. *J Mar Biol Assoc UK* 47:81–95
- Southward AJ (1976) On the taxonomic status and distribution of *Chthamalus stellatus* in the north east Atlantic region. *J Mar Biol Assoc UK* 56:1007–1028
- Southward AJ (1980) The western English Channel—an inconstant ecosystem? *Nature* 285:361–366
- Southward AJ (1991) 40 years of changes in species composition and population-density of barnacles on a rocky shore near Plymouth. *J Mar Biol Assoc UK* 71:495–513
- Southward AJ, Crisp DJ (1954a) The distribution of certain intertidal animals around the Irish coast. *Proc R Ir Acad B* 57:1–29
- Southward AJ, Crisp DJ (1954b) Recent changes in the distribution of the intertidal barnacles *Chthamalus stellatus* Poli and *Balanus balanoides* in the British Isles. *J Anim Ecol* 23:163–177
- Southward AJ, Crisp DJ (1956) Fluctuations and abundance in the distribution and abundance of intertidal barnacles. *J Mar Biol Assoc UK* 35:211–229
- Southward AJ, Southward EC (1978) Recolonisation of rocky shores in Cornwall after the use of toxic dispersants to clean up the Torrey Canyon oil spill. *J Fish Res Board Can* 35:682–706
- Southward AJ, Southward EC (1988) Disappearance of the warm-water hermit crab *Clibanarius erythropus* from southwest Britain. *J Mar Biol Assoc UK* 68:409–412
- Southward AJ, Hawkins SJ, Burrows MT (1995) 70 years observations of changes in distribution and abundance of zooplankton and intertidal organisms in the western English Channel in relation to rising sea temperature. *J Therm Biol* 20:127–155
- Southward AJ, Langmead O, Hardman-Mountford NJ, Aiken J and others (2005) Long-term oceanographic and ecological research in the western English Channel. *Adv Mar Biol* 47:1–105
- Svensson CJ, Jenkins SR, Hawkins SJ, Aberg PA (2005) Population resistance to climate change: modelling the effects of low recruitment in open populations. *Oecologia* 142: 117–126
- Svensson CJ, Johansson E, Aberg P (2006) Competing species in a changing climate: effects of recruitment disturbances on two interacting barnacle species. *J Anim Ecol* 75:765–776
- Terlizzi A, Scuderi D, Frascchetti S, Anderson MJ (2005) Quantifying effects of pollution on biodiversity: a case study of highly diverse molluscan assemblages in the Mediterranean. *Mar Biol* 148:293–305
- Thomas MLH (1986) A physically derived exposure index for marine shorelines. *Ophelia* 25:1–13
- Thompson RC, Wilson BJ, Tobin ML, Hill AS, Hawkins SJ (1996) Biologically generated habitat provision and diversity of rocky shore organisms at a hierarchy of spatial scales. *J Exp Mar Biol Ecol* 202:73–84
- Thompson RC, Norton TA, Hawkins SJ (2004) Physical stress and biological regulation control pattern and process in benthic biofilms. *Ecology* 85:1372–1382
- Thorson G (1950) Reproductive and larval ecology of marine bottom invertebrates. *Biol Rev Camb Philos Soc* 25:1–45
- Tilman D, Reich PB, Knops JMH (2006) Biodiversity and ecosystem stability in a decade-long grassland experiment. *Nature* 441:629–632
- Wetley DS (1980) Consequences of variation in settlement of inter-tidal barnacles. *Am Zool* 20:947
- Wetley DS (1982) Inter-tidal zonation and geographic limits: the barnacles *Balanus* and *Chthamalus* in New England. *Am Zool* 22:883
- Wetley DS, Woodin SA (2008) Ecological hindcasting of biogeographic responses to climate change in the European intertidal zone. *Hydrobiologia* 606:139–151
- Woehrling D, Lefebvre A, Fevre-Lehorff GL, Delesmont R (2005) Seasonal and longer term trends in sea temperature along the French North Sea coast 1975–2002. *J Mar Biol Assoc UK* 85:39–48
- Wootton JT, Pfister CA, Forester JD (2008) Dynamic patterns and ecological impacts of declining ocean pH in a high-resolution multi-year dataset. *Proc Natl Acad Sci USA* 105: 18848–18853



Effects of plant diversity on primary production and species interactions in brackish water angiosperm communities

Tiina Salo*, Camilla Gustafsson, Christoffer Boström

Åbo Akademi University, Environmental and Marine Biology, Artillerigatan 6, 20520 Åbo, Finland

ABSTRACT: Research on plant biodiversity and ecosystem functioning has mainly focused on terrestrial ecosystems, and our understanding of how plant species diversity and interactions affect processes in marine ecosystems is still limited. To investigate if plant species richness and composition influence plant productivity in brackish water angiosperm communities, a 14 wk field experiment was conducted. Using a replacement design with a standardized initial aboveground biomass, shoots of *Zostera marina*, *Potamogeton filiformis* and *P. perfoliatus* were planted on a shallow, sandy bottom in replicated monocultures and all possible species combinations. Response variables included aboveground and belowground biomass, shoot density, space occupation and porewater nutrients. To determine whether selection and/or complementarity controlled productivity, additive partitioning and D_i were calculated. Richness effects were species-specific and only increased the biomass production of *P. perfoliatus* and tuber production of *P. filiformis*, while species composition generally had a stronger effect on biomass production. Additive partitioning indicated a positive complementarity effect for the aboveground biomass production in bicultures in general, while a positive net effect was found in the *P. perfoliatus* and *P. filiformis* biculture. Despite the absence of significant results for other treatments and plant variables, a trend of positive complementarity and negative selection effects were present. Plant diversity had no clear effect on sediment porewater nutrient concentrations, indicating weak richness effects on resource use.

KEY WORDS: Seagrass · Ecosystem function · Complementarity · Selection · Resource use

Resale or republication not permitted without written consent of the publisher

INTRODUCTION

As the relationship between biodiversity and ecosystem function (BEF; usually primary production) has mainly been based on experimental work in terrestrial plant ecosystems (e.g. Hooper & Vitousek 1997, Hector et al. 1999, Loreau et al. 2001), it is still largely unknown to what extent terrestrial plant ecosystem processes are transferable to vegetated marine ecosystems (Solan et al. 2006). Experimental work manipulating different levels of diversity in marine systems have mostly shown significant effects of species richness. Specifically, these studies have shown the following: (1) in terms of primary producers and sessile animals, the effects of individual species are stronger than the role of diversity per se; (2) diverse communities

tend to be less variable, with enhanced resistance and faster recovery from disturbance compared to simple communities; and (3) diverse prey assemblages show higher resistance to predation compared to simple communities (Stachowicz et al. 2007). However, within BEF research, only about 10 field studies (e.g. Stachowicz et al. 2007) manipulating submerged macrophyte species (or genotypic) richness have been published, the majority being experiments with macroalgae, and only a couple of experiments have investigated effects of angiosperm (seagrass) species richness on ecosystem functioning (Parker et al. 2001, Moore & Fairweather 2006). This is surprising given the strong research emphasis on plants within terrestrial BEF work and the similarities between aquatic and terrestrial angiosperm assemblages (Duarte 2000).

*Email: tiina.salo@abo.fi

Seagrass meadows provide vital functions (primary production, nutrient cycling), goods (habitat, food resources) and services (erosion control, indicator of coastal health), but are lost at accelerating rates due to human pressures (Duarte 2000, Orth et al. 2006). Half of the documented seagrass meadows are multispecific and contain 2 to 3 co-occurring species, while Asian seagrass meadows may consist of >10 co-occurring species (Duarte et al. 2000). Interestingly, the angiosperm assemblages in the Baltic Sea have comparable plant species (>10) and functional richness (Kautsky 1988), and multispecific meadows commonly contain 3 to 6 plant species of marine and limnic origin (Boström et al. 2003). However, due to the scarcity of field manipulations, the extent to which plant species diversity influences biological processes in seagrass meadows is still largely unexplored (Williams 1990, Kautsky 1991, Duarte et al. 2000).

Because plant species affect biogeochemical processes differently, the species diversity in an ecosystem influences the processes of that system (Tilman et al. 1997, Hooper 1998). If species are complementary, communities with a large repertoire of different functional groups should either utilize available resources more efficiently and thus show greater productivity compared to simple communities, i.e. a niche-differentiation effect (Tilman 1999, Loreau 2000), or enhance ecosystem-level processes due to beneficial intra- or interspecific interactions, i.e. facilitation (Cardinale et al. 2002, Srivastava & Vellend 2005). However, while the relative role of individual species in a community may vary greatly, resource use and productivity is often expected to increase as diversity increases, simply because one or a few dominating species frequently affect a process the most, i.e. a selection effect (Hooper et al. 2005). Furthermore, species composition may affect processes in such a way that specific combinations of species have a higher impact on processes than other species combinations, though the number of species is the same (Stachowicz et al. 2007). Which of these mechanisms are important for ecosystem functioning of aquatic vegetated systems is still largely unknown (Duarte et al. 2000, Engelhardt & Ritchie 2002), thus limiting our ability to predict consequences of species loss and disturbance, as well as the resistance and recovery capacity of multispecific plant assemblages.

While work in terrestrial grasslands suggests that species with, for example, differing rooting depths and nutrient requirements should be able to coexist, exploit resources more fully and show higher productivity (Fargione & Tilman 2005), there is still limited information on the influence of plant diversity on resource use in marine environments.

The main aim of the present study was to investigate *in situ* how angiosperm species richness and composition influence plant primary production and resource use. We

assembled plots of the following 3 species: *Zostera marina* L., *Potamogeton perfoliatus* L. and *P. filiformis* Pers. These species differ markedly in terms of morphological traits, biomass allocation patterns and productivity (Kautsky 1988, 1991), and are considered able to coexist in the Baltic Sea due to differential resource use (Kautsky 1991). Thus, in addition to species richness, the number of different functional types was also manipulated, which allows for a better understanding of which species traits are important in competitive and/or complementary interactions (Tilman et al. 1997). Furthermore, as all combinations of the plant species were manipulated in a replicated field experiment, the relative importance of complementarity and selection effects in angiosperm assemblages was also assessed.

We hypothesized that species complementarity would result in more efficient resource use (decreased sediment nutrient pool concentrations) and higher production in mixed cultures compared to monocultures, while a positive selection effect would be present in mixtures containing *Potamogeton perfoliatus* and/or *Zostera marina* due to their high production capacity. In terms of spatial partitioning, *Z. marina* and *P. perfoliatus* were hypothesized to show extensive lateral spread, while *P. filiformis* was expected to show moderate space occupation capacity (see Kautsky 1988).

MATERIALS AND METHODS

Study area and site characteristics. The non-tidal northern Baltic Sea is characterized by low salinity (6 to 8 PSU), strong seasonal temperature fluctuations (0 to 20°C) and mixed macrophyte communities (Kautsky 1988, Kautsky & Kautsky 2000). The present study was conducted in the Archipelago Sea, SW Finland, where submerged sandbanks support diverse macrophyte assemblages (Boström et al. 2006). The average water depth at the study site (Fårö Island, 59° 55.219' N, 21° 47.711' E) was 1.3 m, and the area is relatively exposed to NE winds. The nearshore area is mostly unvegetated and consists of a sediment dominated by fine (~70% 0.125 mm) to very fine (~5% 0.0062 mm) sand with low (<0.5%) organic content. A seagrass meadow dominated by eelgrass *Zostera marina*, sago pondweed *Potamogeton pectinatus* L. and perfoliate pondweed *P. perfoliatus* grows from 2 to 6 m depth. Slender-leaved pondweed *P. filiformis* and horned pondweed *Zannichellia palustris* L. grow both within the meadow and in monocultures bordering the meadow, while Eurasian water-milfoil *Myriophyllum spicatum* L. and ditchgrass *Ruppia cirrhosa* (Petagna) Grande occur patchily within the meadow. During the present study, the water temperature ranged between 10°C (October) and 20°C (July).

Experimental setup and sampling. The plant species used in the experiment were *Zostera marina*, *Potamogeton filiformis* and *P. perfoliatus*. A replacement design with a standardized aboveground biomass was used (Harper 1977). Thus, the total start aboveground biomass in all plots was 30 g wet weight (WW), i.e. 30 g of a species in monocultures, 15 g of each component species in bicultures and 10 g of each component species in the triculture. This total biomass corresponded to 21, 26 and 37 shoots for *Z. marina*, *P. filiformis* and *P. perfoliatus*, respectively. Plants were grown in all possible combinations (7 treatments) in a randomized block design with 4 replicates of each treatment. The distance between plots was 2 m and the distance between blocks was 2.5 m. Two weeks prior to the start of the experiment, scattered plants and stones were removed from the unvegetated area.

When starting the experiment, experimental plants (ramets) were collected from the study site and transplanted within 8 h. To estimate the initial dry weight (DW) of aboveground and belowground biomass, 20 to 30 randomly chosen plants of each species were set aside. To standardize plant spacing and prevent uprooting, plants were carefully tied to a flexible 30 × 30 cm plastic grid (mesh size 30 mm). In mixed plots, individual component species were tied in a non-random, even spatial pattern, avoiding grouping of conspecifics. Plants were kept submerged during the handling process. Experimental units were planted 3 to 5 cm into the sediment using SCUBA diving. In addition, empty grids used as controls for sediment nutrients were positioned randomly within each block (n = 4). The experiment ran for 14 wk (10 July to 21 October 2007), representing one growing season.

To estimate the potential influence of plant species richness on organic matter deposition and mineralization, sediment cores (diameter 2.5 cm, depth 5 cm) were taken for sediment C:N determination 1 mo prior to the termination of the experiment (11 September). The C:N samples were sieved (0.5 mm), dried (105°C, 24 h) and ground, and subsequently analyzed in a certified lab according to the method of Kristensen & Andersen (1987) with an elemental analyzer (Carlo-Erba 1100EA). Three days prior to the termination of the experiment, (i.e. after ~13 wk, when plots had reached maximum development), the space occupation capacity through clonal growth of each species in each plot was assessed by measuring the maximum spatial expansion (cm) from the initial plot edge. All plots were also sampled for sediment porewater nutrients using Rhizon soil moisture samplers (type SMS: length 100 mm, Ø 2.5 mm, Eijelkamp Agrisearch Equipment) connected to 125 ml vacuum bottles. The sampler was inserted to 10 to 12 cm depth in the center

of each plot (thus covering the entire root layer) and connected to a vacuum bottle with a PVC tube and a syringe. Porewater samples were kept in the dark and deep-frozen (-20°C) upon arrival at the laboratory, and analyzed for NH₄⁺ and PO₄³⁻ in a certified lab. In addition, water column nutrient samples (total N, total P, NH₄⁺, PO₄³⁻) were taken from the experimental area on 20 August, 5 September and 2 and 21 October, and treated as outlined above.

At the termination of the experiment, all plant material including belowground parts in each plot was harvested (except for one replicate of the *Potamogeton perfoliatus* monoculture which was lost), transported to the laboratory and deep frozen (-18°C). In the laboratory, samples were thawed and plants were carefully cleansed from animals, algae, etc. The number of shoots, as well as the aboveground (shoots) and belowground (rhizomes, roots) biomass, was determined for each species. The biomass (DW) was determined on an analytical scale after drying to constant weight (48 h, 60°C). In addition, the number and biomass (DW) of overwintering organs was determined for all *P. filiformis* (tubers) and *P. perfoliatus* (turions) ramets. To compensate for the initial differences in planting biomasses, tuber and turion abundances were multiplied by 2 and 3 in bicultures and tricultures, respectively, see Engelhardt & Ritchie (2002).

Data analysis. To determine the mechanisms explaining observed patterns, additive partitioning of biodiversity effects was used to assess the importance of selection (SE), complementarity (CE) and net biodiversity effect (NE) in mixed cultures (Loreau & Hector 2001). In addition, D_i was calculated to describe how the yield of a species in polyculture differs from its expected yield (Loreau 1998):

$$D_i = (O_i - E_i)/E_i$$

where O_i and E_i are the observed and expected yields of species i , respectively.

One-way ANOVA and regression analysis were performed to detect differences in plant variables. Prior to analysis, Kolmogorov-Smirnov and Levene's tests were used to test if data fulfilled assumptions for parametric testing. In some cases data, were log-transformed to fulfill these assumptions. In case of heteroscedasticity and for calculations involving percentage values >100, a non-parametric Kruskal-Wallis test accompanied by a Mann-Whitney U -test was used. Additive partitioning and D_i were calculated for aboveground, belowground and total biomass production. The calculated indices were tested against a value of 0.0 with a 1-sample t -test. To correct for multiple comparisons, results from the t -tests were corrected using the Dunn-Sidak method (Sokal & Rohlf 1994). All means are given ±SE.

RESULTS

Biomass allocation patterns and species composition effects

The plant communities differed significantly from each other in terms of aboveground, belowground and total biomass ($H = 25.38$, $p = 0.017$; $H = 16.01$, $p = 0.014$ and $H = 15.44$, $p = 0.017$, respectively, Fig. 1). The number of shoots per plot varied between 14 ± 3 (*Potamogeton perfoliatus* monoculture) and 218 ± 31 (*P. filiformis* monoculture) (Fig. 1a). The final accumulated aboveground biomass ranged between 0.3 ± 0.1 (*P. perfoliatus* monoculture) and 4.3 ± 0.4 g DW (biculture of *Zostera marina* and *P. filiformis*), while belowground biomasses were generally higher and ranged from 1.2 ± 0.3 (*P. perfoliatus* monoculture) to 6.0 ± 1.6 g DW (*Z. marina* monoculture) (Fig. 1b,c). The total plot biomass ranged from 1.5 ± 0.3 (*P. perfoliatus* monoculture) to a maximum of 10 ± 2.6 g DW (*Z. marina* monoculture) (Fig. 1d). As root:shoot (R:S) ratios did not differ for individual species across treatments, ratios were pooled. Thus, *P. perfoliatus* and *Z. marina* invested most in belowground biomass, with R:S ratios of 2.9 ± 0.1 and 1.5 ± 0.1 , respectively, while *P. filiformis* allocated most of its production to shoots (R:S ratio of 0.9 ± 0.03). For *Z. marina*, the spatial expansion in terms of

clonal growth ranged between 25.8 ± 4.2 (biculture with *P. perfoliatus*) and 32.8 ± 2.8 cm (monoculture), and for *P. perfoliatus* from 18.3 ± 4.4 (biculture with *Z. marina*) to 25.0 ± 7.6 cm (biculture with *P. filiformis*). The highest space occupation capacity was recorded for *P. filiformis* (42.3 ± 6.2 [triculture] to 62.5 ± 2.2 cm [monoculture]).

Species composition had a strong effect on the community performance. When present, *Zostera marina* significantly increased the belowground and total biomass production of the plant communities by 42 and 34%, respectively (Table 1) ($F_{1,10} = 8.793$, $p = 0.014$; $F_{1,10} = 7.142$, $p = 0.023$). Similarly, *Potamogeton filiformis* contributed significantly to the shoot density, with 160% more shoots in communities with the species present ($F_{1,10} = 73.302$, $p < 0.001$), while the presence of *P. perfoliatus* led to 35% lower aboveground biomasses ($F_{1,10} = 15.876$, $p = 0.003$).

Temporal changes in plant communities and richness effects

When comparing the performance of individual species in different mixtures, the relative (%) temporal change in shoot density (ramet production), aboveground, belowground and total biomass production

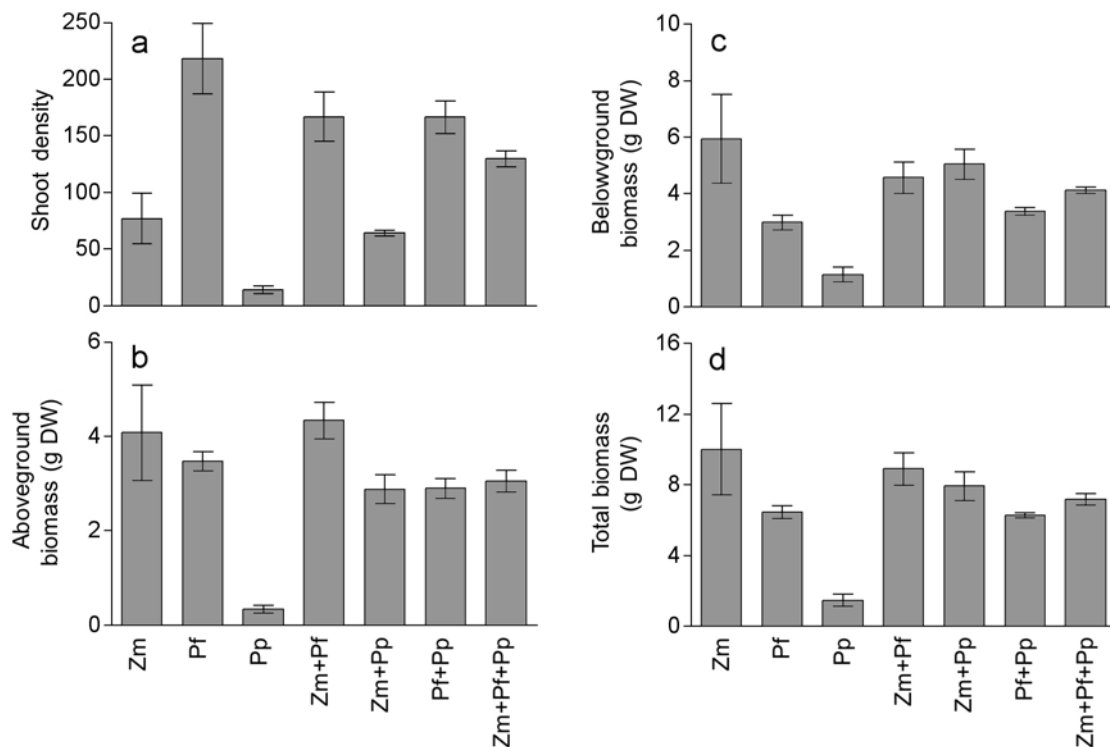

Fig. 1. *Zostera marina*, *Potamogeton filiformis* and *P. perfoliatus*. Mean (a) shoot densities, (b) aboveground biomass, (c) belowground biomass and (d) total biomass in the assembled plant communities. Zm: *Z. marina*; Pf: *P. filiformis*; Pp: *P. perfoliatus*. Error bars are \pm SE

Table 1. *Zostera marina*, *Potamogeton filiformis* and *P. perfoliatus*. Mean (\pm SE) shoot density, aboveground biomass, belowground biomass and total biomass in the presence and absence of each component species in the experimental communities. Asterisks indicate significant differences in community performance in the presence versus absence of a component species: * $p < 0.05$; ** $p < 0.005$. DW: dry weight

Species		Shoot density	Aboveground biomass (g DW)	Belowground biomass (g DW)	Total biomass (g DW)
<i>Z. marina</i>	Presence	115.6 \pm 21.9	3.6 \pm 0.4	4.8 \pm 0.4*	8.4 \pm 0.6*
	Absence	117.0 \pm 14.5	2.9 \pm 0.2	3.4 \pm 0.1	6.3 \pm 0.1
<i>P. filiformis</i>	Presence	166.9 \pm 12.1**	3.6 \pm 0.3	4.0 \pm 0.3	7.5 \pm 0.7
	Absence	64.3 \pm 2.8	2.9 \pm 0.3	5.0 \pm 0.5	7.9 \pm 0.8
<i>P. perfoliatus</i>	Presence	115.5 \pm 20.5	2.9 \pm 0.2**	4.2 \pm 0.4	7.1 \pm 0.5
	Absence	167.0 \pm 21.8	4.3 \pm 0.4	4.6 \pm 0.6	8.9 \pm 0.9

generally showed minor differences (Fig. 2). *Potamogeton filiformis* had the lowest production in monocultures, though this was non-significant, while *P. perfoliatus* performed significantly better in mixed cultures in terms of shoot density and aboveground biomass investment ($H = 9.7$, $p = 0.021$ and $H = 9.9$, $p = 0.019$, respectively). In particular, *P. perfoliatus* had a significantly higher ramet production in tricultures than in bicultures with *P. filiformis* ($U = 0.000$, $p = 0.029$, Fig. 2). Compared to its starting density, *P. filiformis* increased its shoot density by 1 order of magnitude (biculture with *P. perfoliatus*), while *P. perfoliatus* and *Zostera marina* reached, at maximum, ~ 0.5 and > 3

times their initial densities, respectively (Fig. 2a). The relative increase in aboveground biomass followed the shoot density pattern (Fig. 2b), while the change in belowground biomass was surprisingly uniform between species and across treatments (Fig. 2c).

When measuring the relative (%) temporal change in terms of shoot density and aboveground biomass production at the plot level in mixed cultures, the greatest change was found in the biculture of *Zostera marina* and *Potamogeton filiformis* (Fig. 3a,b). In terms of belowground biomass, the greatest change was recorded in the biculture of *Z. marina* and *P. perfoliatus* (Fig. 3c), while in terms of total biomass the biculture

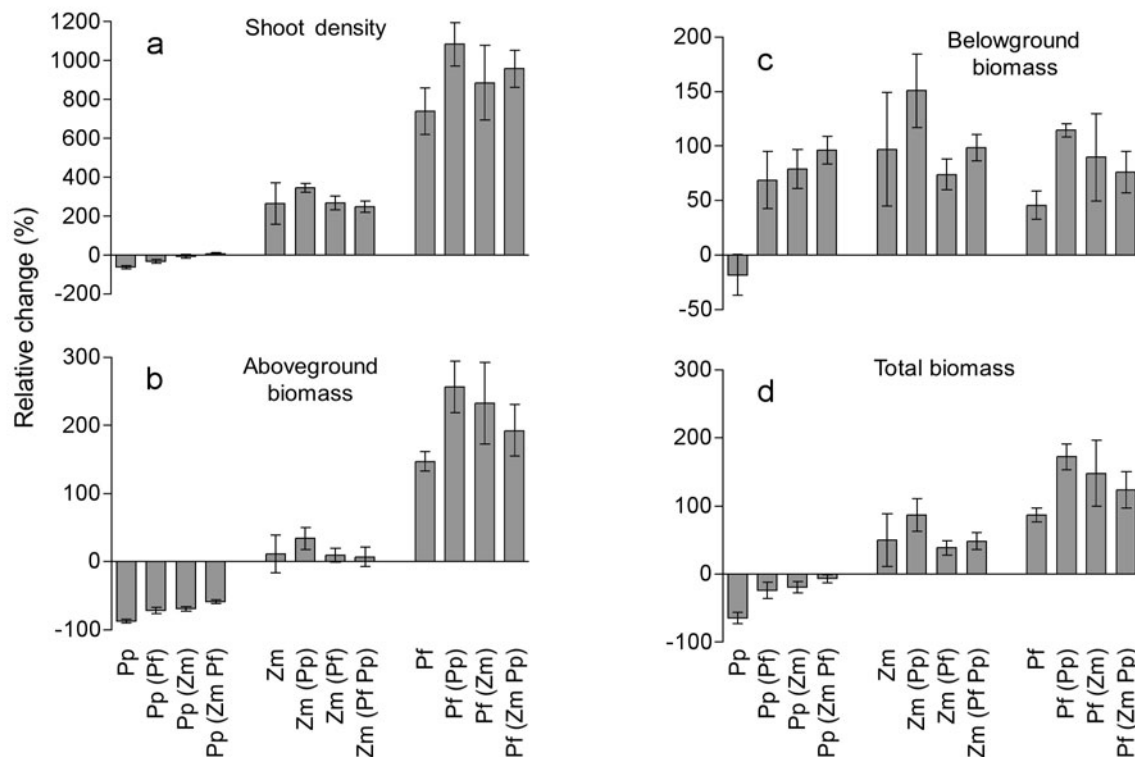

Fig. 2. *Zostera marina*, *Potamogeton filiformis* and *P. perfoliatus*. Relative (%) change in (a) shoot density, (b) aboveground biomass, (c) belowground biomass and (d) total biomass. Species in parentheses indicate other species present in the culture but not represented by the bars. Species abbreviations as in Fig. 1. Data are means \pm SE

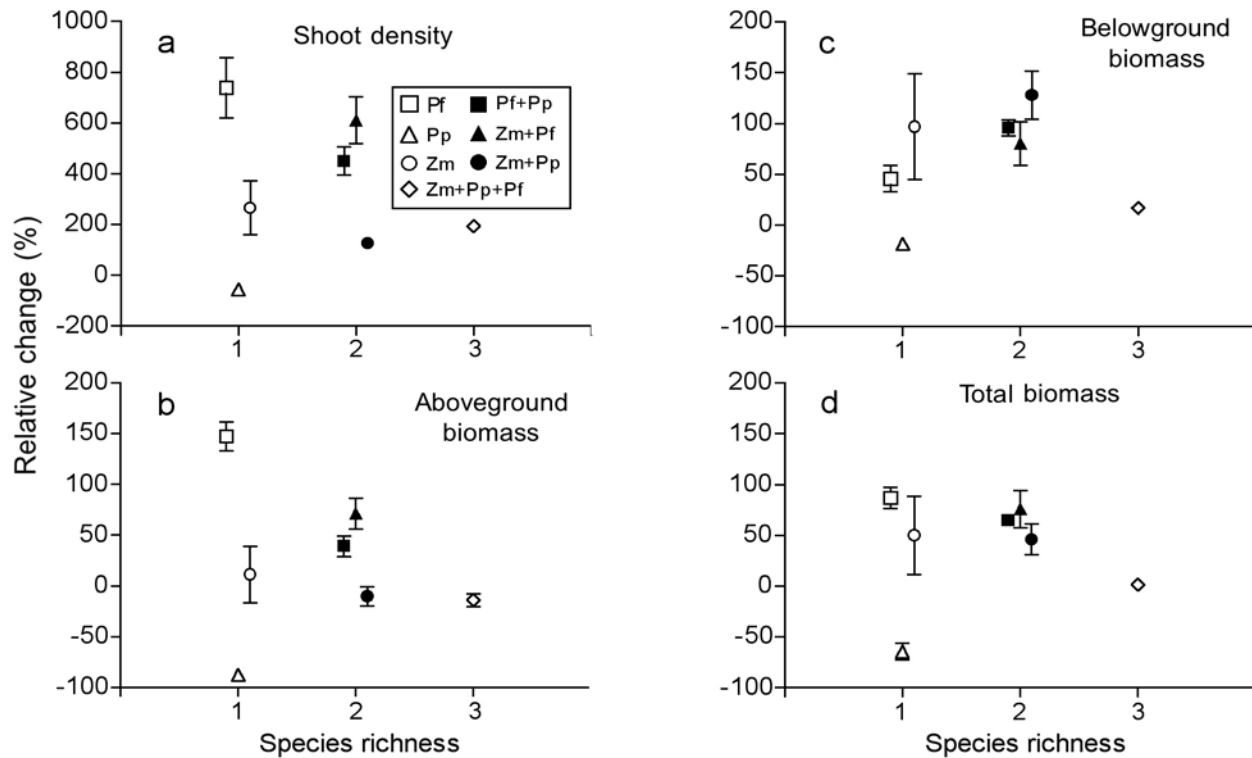

Fig. 3. *Zostera marina*, *Potamogeton filiformis* and *P. perfoliatus*. Relative (%) change in (a) shoot density, (b) aboveground biomass, (c) belowground biomass and (d) total biomass in relation to species richness. Species abbreviations as in Fig. 1. Data are means \pm SE (not visible for all treatments due to scale)

of *Z. marina* and *P. filiformis* expressed the greatest relative change (Fig. 3d). The different treatments differed significantly from each other in terms of shoot density ($H = 22.1$, $p = 0.001$), aboveground biomass ($H = 22.3$, $p = 0.001$), belowground biomass ($H = 16.0$, $p = 0.014$) and total biomass ($H = 15.6$, $p = 0.016$).

For *Potamogeton perfoliatus*, species richness enhanced all biomass production variables, while *P. filiformis* and *Zostera marina* showed nonlinear relation-

ships with increasing species number (Table 2, Fig. 4). The number of tubers and turions of *P. filiformis* and *P. perfoliatus*, respectively, correlated positively with species richness (tubers: $F_{1,14} = 8.882$, $p = 0.010$, $r^2 = 0.388$; turions: $F_{1,13} = 5.631$, $p = 0.034$, $r^2 = 0.302$) (Fig. 5).

Additive partitioning and D_i

The aboveground, belowground and total biomass production in biculture treatments showed similar, but non-significant, responses with positive CE and negative SE resulting in a positive NE. However, the biculture consisting of *Potamogeton filiformis* and *P. perfoliatus* showed a significant positive NE for total biomass production (t -test, $p = 0.004$). The triculture treatment also showed non-significant positive CE and negative SE for all the measured plant variables, resulting in a negative NE (Fig. 6). In terms of species richness, bicultures showed a significant positive CE for aboveground biomass (t -test, $p = 0.016$) (Fig. 6), while the other plant variables were non-significant and followed the same trend of positive CE and negative SE as described above.

Table 2. *Zostera marina*, *Potamogeton filiformis* and *P. perfoliatus*. Simple linear regression results for responses to increasing plant species richness in the field experiment

Species	Plant variable	df	F	p	r^2
<i>P. perfoliatus</i>	Shoot density	1,13	20.7	0.001	0.610
	Aboveground biomass	1,13	12.88	0.003	0.500
	Belowground biomass	1,13	34.35	<0.001	0.730
	Total biomass	1,13	17.26	0.001	0.570
<i>P. filiformis</i>	Shoot density	1,14	0.41	0.843	0.003
	Aboveground biomass	1,14	0.03	0.867	0.002
	Belowground biomass	1,14	0.001	0.972	0.000
	Total biomass	1,14	0.002	0.964	0.000
<i>Z. marina</i>	Shoot density	1,14	1.3	0.274	0.085
	Aboveground biomass	1,14	0.56	0.469	0.038
	Belowground biomass	1,14	0.76	0.399	0.051
	Total biomass	1,14	0.68	0.425	0.046

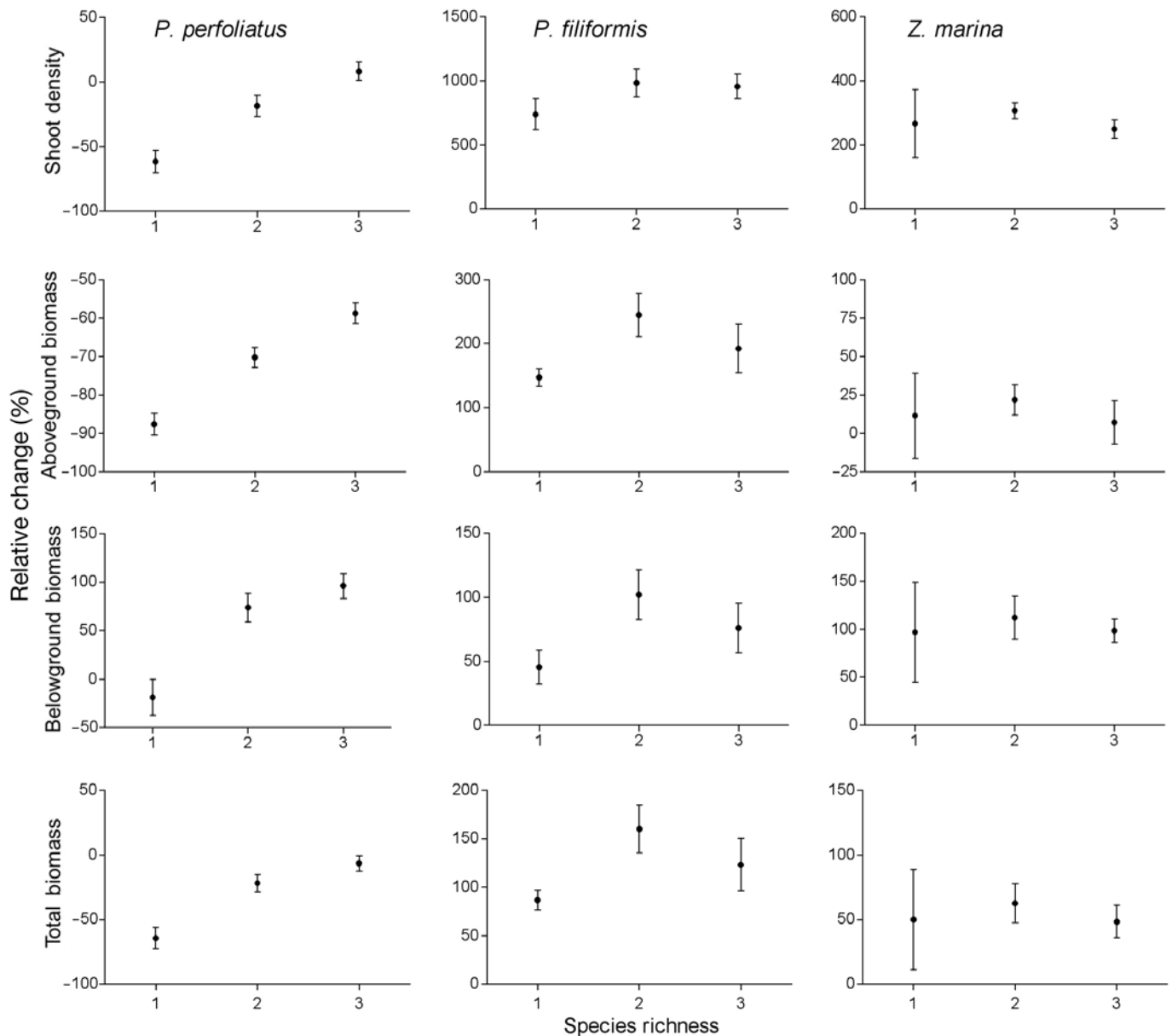

Fig. 4. *Zostera marina*, *Potamogeton filiformis* and *P. perfoliatus*. Relative (%) change in aboveground biomass, belowground biomass and total plant biomass and shoot density for each species in relation to species richness. Data are means \pm SE

All treatments showed positive D_i values indicating that all species performed better in mixes than expected (Table 3). However, none of these D_i values were statistically significant.

Sediment and water column nutrients

The C:N ratio was low in all treatments including controls, and ranged from 3.9 to 4.5, with no richness effects ($F_{1,29} = 4.0$, $p = 0.055$, $r^2 = 0.121$). The control plots revealed significantly higher porewater NH_4^+ concentra-

tions compared to other treatments ($F_{7,22} = 6.5$, $p < 0.001$), while none of the individual plant treatments differed in terms of porewater nutrient concentrations. Among plant treatments, the NH_4^+ concentration ranged between 12.6 ± 4.1 (*Potamogeton filiformis* monoculture) and 22.3 ± 9.0 μM (triculture). In terms of richness, the NH_4^+ concentration was highest in the control treatments (67.2 ± 13.5 μM), lowest in monocultures (14.4 ± 2.5 μM) and increased somewhat with increasing species richness (quadratic regression: $F_{2,27} = 15.95$, $p < 0.001$, $r^2 = 0.54$, Fig. 7a). The porewater PO_4^{3-} concentration ranged between 1.91 ± 0.78 (*Zostera marina* and *P. perfoliatus*

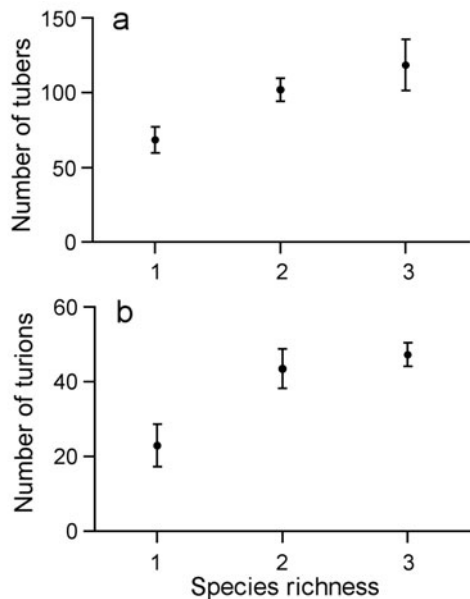

Fig. 5. *Potamogeton filiformis* and *P. perfoliatus*. Compensated number of (a) tubers (*P. filiformis*) and (b) turions (*P. perfoliatus*) in relation to species richness. Data are means \pm SE

biculture) and $0.63 \pm 0.19 \mu\text{M}$ (*P. perfoliatus* monoculture), but did not differ between treatments ($F_{7,22} = 0.89$, $p = 0.53$). The PO_4^{3-} concentration in the controls was $1.45 \pm 0.55 \mu\text{M}$. No relationship between species richness and porewater PO_4^{3-} concentration was found ($F_{1,28} = 0.05$, $p = 0.82$, $r^2 = 0.002$, Fig. 7b). Compared to the sediment nutrient pools, water column nutrient concentrations were substantially lower and ranged during the season from 0.17 to 0.38 μM (total N: 17.1 to 24.3 μM) and 0.05 to 0.17 μM (total P: 0.59 to 0.64 μM) for NH_4^+ and PO_4^{3-} , respectively.

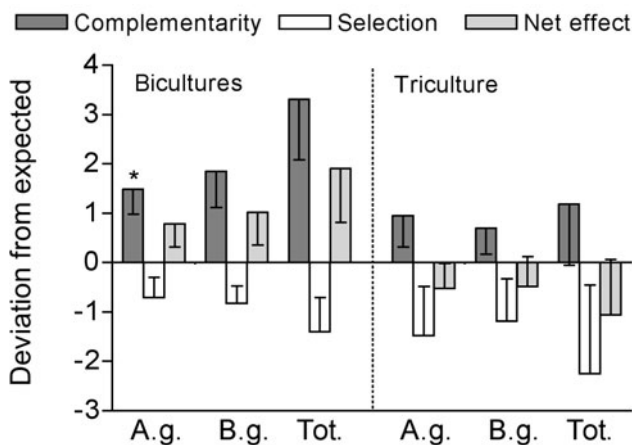

Fig. 6. *Zostera marina*, *Potamogeton filiformis* and *P. perfoliatus*. Additive partitioning of aboveground biomass (A.g.), belowground biomass (B.g.) and total biomass (Tot.) in the bicultures and the triculture. Asterisk denotes a significant ($p = 0.016$) effect. Data are means and SE

Table 3. *Zostera marina*, *Potamogeton filiformis* and *P. perfoliatus*. Species performance (D_i , mean \pm SE) calculated for aboveground, belowground and total biomass production in mixed cultures. Asterisks in parentheses indicate significant differences from 0.0 ($p < 0.05$) that disappeared after correcting for multiple comparisons. Zm: *Zostera marina*; Pf: *Potamogeton filiformis*; Pp: *P. perfoliatus*

Plant culture	Aboveground biomass	Belowground biomass	Total biomass
Zm bicultures	0.82 ± 0.68	1.00 ± 0.82	0.92 ± 0.76
Zm triculture	0.23 ± 0.37	0.51 ± 0.65	0.39 ± 0.53
Pf bicultures	0.43 ± 0.19	$0.39 \pm 0.12^*$	$0.40 \pm 0.14^*$
Pf triculture	0.21 ± 0.21	0.26 ± 0.20	0.22 ± 0.19
Pp bicultures	$1.56 \pm 0.50^*$	$1.27 \pm 0.45^*$	$1.34 \pm 0.46^*$
Pp triculture	2.77 ± 1.31	1.72 ± 0.95	1.96 ± 1.03

DISCUSSION

Species interactions among rooted macrophytes

The results obtained in the present study indicate that ecosystem processes in macrophyte assemblages are influenced by species composition. Among the species tested, positive CE and negative SE were recorded, thus leading to both a positive and negative NE depending on the treatment. While complementarity did not lead to a significant increase in resource use, facilitation is suggested to occur in the communities. We found no increase in total primary production with increasing plant richness. The richness effects recorded were weak and species-specific, i.e. an enhanced biomass production of *Potamogeton perfoliatus* and tuber production of *P. filiformis*, while *Zostera marina* appeared unaffected by the presence of other species. To our knowledge, this is the first manipulative aquatic *in situ* BEF study on interactions and resource use among angiosperm species.

In marine ecosystems, the relationship between macrophyte richness and primary productivity is strongly influenced by species composition, while richness effects are generally non-existent or weak (Stachowicz et al. 2007). In the present study, richness effects were only found for *Potamogeton perfoliatus*, which increased its shoot density and biomass production with increasing species richness. In addition, the tuber production of *P. filiformis* correlated positively with species number. Richness effects may be dependent on the duration of the experiment. In accordance with the present study, short-term terrestrial grassland experiments have not found a relationship between species richness and primary production (Naeem et al. 1996, Weigelt et al. 2007), while positive correlations have emerged from long-term studies (Hector et al. 1999, Roscher et al. 2007). Since the production of previous years may alter

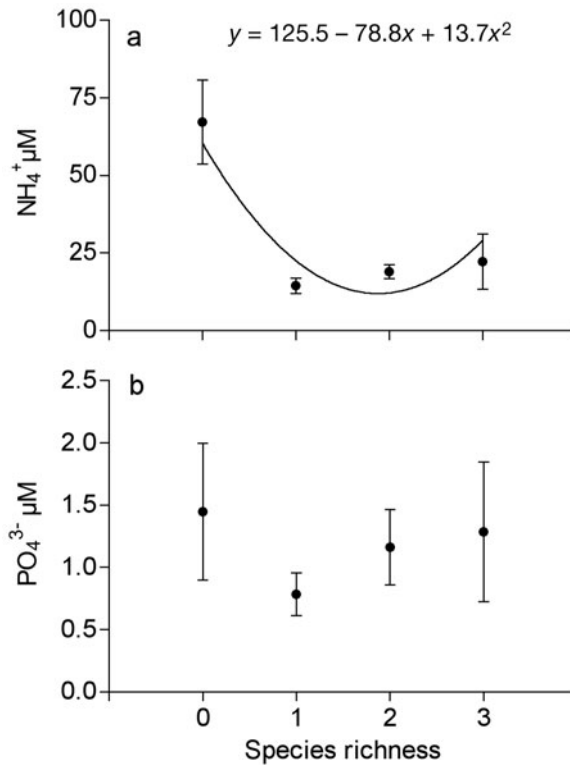

Fig. 7. *Zostera marina*, *Potamogeton filiformis* and *P. perfoliatus*. Relationships between sediment porewater nutrient concentration and plant species richness. (a) NH_4^+ (quadratic regression: $p < 0.001$, $r^2 = 0.54$). (b) PO_4^{3-} (no relationship was found). Data are means \pm SE

long-term patterns in plant communities, short-term experiments may fail to detect species complementarity (Hooper & Dukes 2004). Alternatively, biodiversity effects in marine plant communities may, compared to terrestrial ecosystems, be subordinated in comparison to more influential limiting factors such as irradiance, waves and currents, nutrients, epiphytes and sediment characteristics. Thus, in order to fully capture potential biodiversity effects in aquatic plant communities, future manipulations should preferentially span several years and include different environmental settings (Cardinale et al. 2000, 2007).

In accordance with macroalgal BEF studies (Bruno et al. 2005, 2006), compositional effects had a strong effect on primary production. For example, *Zostera marina* enhanced both the total community and belowground production, while *Potamogeton filiformis* significantly contributed to increased ramet production. Similarly, in tropical seagrass systems, the community composition is thought to be of greater importance for the maintenance of ecosystem functions than the number of species per se (Duarte 2000).

The positive CE recorded in the present study indicates the presence of either facilitation or niche parti-

tioning (Bertness & Callaway 1994, Loreau & Hector 2001, Duffy 2006). Our findings are supported by the results of Kautsky (1991), who observed complementarity between *Potamogeton filiformis* and *P. perfoliatus* and suggested this was due to the differences in rooting depths. Surprisingly, the sediment porewater nutrient concentrations were higher in the biculture and triculture treatments compared to the monocultures. Thus, complementary nutrient use is unlikely to explain this positive effect. Other forms of positive interactions, e.g. enhanced oxygen release to the rhizosphere (Caffrey & Kemp 1991, Callaway & King 1996) or increased nutrient use efficiency (van Ruijven & Berendse 2005), may possibly explain this result.

The frequent occurrences of negative SE among treatments indicate that the communities were dominated by species with lower than average monoculture biomass. In the triculture, this effect was strong enough to cancel out the positive CE, resulting in a negative NE. While the NE was positive in the bicultures, thus suggesting a positive effect of biodiversity, the additive partitioning of the triculture indicated that the production decreased with increasing plant species richness (Loreau & Hector 2001).

Biomass allocation patterns

Biomass allocation patterns were most likely explained by exposure rather than interspecific interactions (Kautsky 1991, Boström et al. 2006). *Potamogeton perfoliatus* invested more into belowground parts than into shoots, while *P. filiformis* tended to show less variable R:S ratios (Kautsky 1988, 1991). The higher relative change in shoot density and aboveground biomass of *P. filiformis* compared to the other species suggests that exposed sandy bottoms represent optimal growing conditions for this species. In contrast, the performance of *P. perfoliatus* monocultures indicate that, despite the morphological plasticity of the species, sediment stability and shelter provided by other plants seem to be a prerequisite for successful population establishment and maintenance in harsh environments (Kautsky 1988, 1991). In a transplantation study in the Baltic Sea (Worm & Reusch 2000), a similar pattern was recorded for young *Zostera marina* plants.

In temperate macrophytes, tuber and turion production is initiated when carbohydrate production exceeds growth demands, and usually peaks towards the end of the season (Santamaría & Llano García 2004). In the present study, species richness correlated positively with tuber and turion abundance, implicating a coupling between interspecific competition and resource investment. As the number of propagules determines the initial density, and thus the ability of a species to

compete for space, light and nutrients early in the following growth season (Kautsky 1990), *Potamogeton filiformis* and *P. perfoliatus* may possess a competitive advantage over other species.

Ramet production and space occupation

In terrestrial plant studies, aboveground and belowground space partitioning has been recorded, e.g. increasing shoot density and cover in mixtures relative to monocultures (Lorentzen et al. 2008). While establishment and ramet production in freshwater plants depends on nutrient status and population density (Wolfer & Straile 2004), little is known about the importance of interspecific competition for space during plant succession in seagrass ecosystems (Williams 1990). Due to the differing repertoire of functional traits among the species studied here, space occupation patterns through clonal growth were species-specific, but not significantly influenced by species richness. However, the shoot density of *Potamogeton filiformis* tended to be higher in mixes compared to monocultures, while the linear increase in shoot density of *P. perfoliatus* only reflected an increase from a negative (-61.4%) to slightly positive (8.5%) level (Fig. 4, see 'Discussion' subsection 'Biomass allocation patterns'). In the study area, *Zostera marina* is a biomass storer with low productivity (Kautsky 1988, Boström et al. 2004) and space occupation appeared to be unaffected by the presence of other species. Based on a mesocosm study, the space occupation of *P. perfoliatus* was suggested to be negatively density-dependent (Wolfer & Straile 2004), but such a pattern was not observed in the present study. The spatial spread of *P. filiformis* was highest in monocultures (>60 cm) compared to mixed cultures. Decreasing space occupation capacity in mixed communities can be explained by interspecific competition (Grime 2001); alternatively, complementarity in mixed communities may result in shorter rhizome spacer lengths and thus increased concentration and foraging ability of ramets in nutrient-rich patches (Wolfer 2008). However, sediment porewater nutrient levels were not significantly lower in the mixed communities, suggesting that interspecific competition is more important (than complementarity) for space occupation capacity.

Sediment porewater nutrients and resource use

Plant richness did not markedly affect the sediment organic deposition and mineralization, thus the C:N ratio did not differ between treatments. The low C:N ratios found in the present study indicate that the organic mat-

ter in the sediment is derived from benthic microalgae (as suggested by Hansen & Kristensen 1998), as seagrass detritus generally has a higher C:N ratio (Kristensen & Hansen 1995, Boschker et al. 2000). Because of differing biomass and penetration depth of rhizomes and roots (*Potamogeton filiformis*: slender roots, ~5 cm depth, *Zostera marina*: extensive rhizomes and roots, ~10 cm depth, *P. perfoliatus*: extensive rhizome, intermediate roots, ~15 cm depth; authors' pers. obs.), we expected to record complementary resource use. As water column nutrients were depleted throughout the productive season at the study site, sediment nutrients likely constituted the main source of nutrients for the plant communities (Hemminga 1998). When *Z. marina* grows on sandy sediments it is often considered N-limited (Short 1987). This is in accordance with the *Z. marina* treatments, with average NH_4^+ concentrations in porewater <100 μM (Fourqurean et al. 1992, present study). The highest porewater NH_4^+ concentration was recorded in unvegetated control plots, while surprisingly, the tri-culture had the highest NH_4^+ concentration among the plant treatments. Thus, in contrast to some terrestrial studies (e.g. Tilman et al. 1997), no resource use complementarity was recorded. This indicates weak richness effects on sediment porewater nutrient concentrations, i.e. plants in our mixed brackish water communities do not appear to use available nutrients more completely than in monocultures.

For some species, a more efficient nutrient use at high species richness has been recorded (van Ruijven & Berendse 2005), which may also explain the observations in the present study. However, in the present study, the leaf nutrient content was not analyzed, so the exact mechanism behind this observation requires further study. In contrast to NH_4^+ , PO_4^{3-} levels did not differ between vegetated and unvegetated plots. Similar patterns have been recorded in the study area (Boström et al. 2004). Surprisingly, the PO_4^{3-} concentration was highest in the biculture of *Zostera marina* and *Potamogeton perfoliatus*, suggesting that despite the non-significant CE found for biomass production, these species did not utilize porewater nutrients as efficiently as other species combinations.

CONCLUSIONS

Our results show that the effects of plant richness per se on primary production and resource use in brackish water plant communities are weak or non-existent. However, species composition appears to be important for both aboveground and belowground production in angiosperm communities. In earlier work (Engelhardt & Ritchie 2002), richness responses of these plant compartments have not been analysed separately for indi-

vidual component species. The present study shows that a substantial part of angiosperm species interactions occurs in the sediment, and that these interactions might differ from aboveground dynamics. Understanding the interactions in multispecific plant communities is challenging, but crucial for determining the consequences of species loss for the functioning of these valuable coastal ecosystems.

Acknowledgements. A. Hector, H. Setälä and J. Mikola provided valuable comments on the experimental design. M. Holmer is acknowledged for help with the C:N analysis. J. Nyström and E. Juslin assisted in the field and laboratory. Korpoström Archipelago Centre provided excellent working facilities. This study was conducted as a part of the project 'Biodiversity and Ecosystem Functioning Under Environmental Stress: Role of Biological Insurance in Aquatic Plant Communities' (C. Boström, Maj and Tor Nessling Foundation, Project 2008216). Additional funding was received from Societas Pro Fauna et Flora Fennica, the Riihi Foundation, the Åbo Akademi Foundation and the Swedish Cultural Foundation.

LITERATURE CITED

- Bertness MD, Callaway R (1994) Positive interactions in communities. *Trends Ecol Evol* 9:191–193
- Boschker HTS, Wielemaker A, Schaub BEM, Holmer M (2000) Limited coupling of macrophyte production and bacterial carbon cycling in the sediments of *Zostera* spp. meadows. *Mar Ecol Prog Ser* 203:181–189
- Boström C, Baden S, Krause-Jensen D (2003) The seagrasses of Scandinavia and the Baltic Sea. In: Green EP, Short FT, Spalding MD (eds) *World atlas of seagrasses: present status and future conservation*. University of California Press, Berkeley, CA, p 27–37
- Boström C, Roos C, Rönnerberg O (2004) Shoot morphometry and production dynamics of eelgrass in the northern Baltic Sea. *Aquat Bot* 79:145–161
- Boström C, O'Brien K, Roos C, Ekeboom J (2006) Environmental variables explaining structural and functional diversity of seagrass macrofauna in an archipelago landscape. *J Exp Mar Biol Ecol* 335:52–73
- Bruno JF, Boyer KE, Duffy JE, Lee SC, Kertesz JS (2005) Effects of macroalgal species identity and richness on primary production in benthic marine communities. *Ecol Lett* 8:1165–1174
- Bruno JF, Lee SC, Kertesz JS, Carpenter RC, Long ZT, Duffy JE (2006) Partitioning effects of algal species identity and richness on benthic marine primary production. *Oikos* 115:170–178
- Caffrey JM, Kemp WM (1991) Seasonal and spatial patterns of oxygen production, respiration and root rhizome release in *Potamogeton perfoliatus* and *Zostera marina*. *Aquat Bot* 40:109–128
- Callaway RM, King L (1996) Temperature-driven variation in substrate oxygenation and the balance of competition and facilitation. *Ecology* 77:1189–1195
- Cardinale BJ, Nelson K, Palmer MA (2000) Linking species diversity to the functioning of ecosystems: on the importance of environmental context. *Oikos* 91:175–183
- Cardinale BJ, Palmer MA, Collins SL (2002) Species diversity enhances ecosystem functioning through interspecific facilitation. *Nature* 415:426–429
- Cardinale BJ, Wright JP, Cadotte MW, Carroll IT and others (2007) Impacts of plant diversity on biomass production increase through time because of species complementarity. *Proc Natl Acad Sci USA* 104:18123–18128
- Duarte CM (2000) Marine biodiversity and ecosystem services: an elusive link. *J Exp Mar Biol Ecol* 250:117–131
- Duarte CM, Terrados J, Agawin NSR, Fortes MD (2000) An experimental test of the occurrence of competitive interactions among SE Asian seagrasses. *Mar Ecol Prog Ser* 197:231–240
- Duffy JE (2006) Biodiversity and the functioning of seagrass ecosystems. *Mar Ecol Prog Ser* 311:233–250
- Engelhardt AM, Ritchie ME (2002) The effect of aquatic plant species richness on wetland ecosystem processes. *Ecology* 83:2911–2924
- Fargione J, Tilman D (2005) Niche differences in phenology and rooting depth promote coexistence with a dominant C_4 bunchgrass. *Oecologia* 143:598–606
- Fourqurean JW, Zieman JC, Powell GVN (1992) Relationships between porewater nutrients and seagrasses in a subtropical carbonate environment. *Mar Biol* 114:57–65
- Grime JP (2001) *Plant strategies, vegetation processes, and ecosystem properties*. John Wiley & Sons, New York
- Hansen K, Kristensen E (1998) The impact of the polychaete *Nereis diversicolor* and enrichment of macroalgal (*Chaetomorpha linum*) detritus on benthic metabolism and nutrient dynamics in organic-poor and organic-rich sediment. *J Exp Mar Biol Ecol* 231:201–223
- Harper JL (1977) *Population biology of plants*. Academic Press, New York
- Hector A, Schmid B, Beierkuhnlein C, Caldeira MC and others (1999) Plant diversity and productivity experiments in European grasslands. *Science* 286:1123–1127
- Hemming MA (1998) The root/rhizome system of seagrasses: an asset and a burden. *J Sea Res* 39:183–196
- Hooper DU (1998) The role of complementarity and competition in ecosystem responses to variation in plant diversity. *Ecology* 79:704–719
- Hooper DU, Dukes JS (2004) Overyielding among functional groups in a long-term experiment. *Ecol Lett* 7:95–105
- Hooper DU, Vitousek PM (1997) The effects of plant composition and diversity on ecosystem processes. *Science* 277:1302–1305
- Hooper DU, Chapin FS III, Ewell JJ, Hector A and others (2005) Effects of biodiversity on ecosystem functioning: a consensus of current knowledge. *Ecol Monogr* 75:3–55
- Kautsky L (1988) Life strategies of aquatic soft bottom macrophytes. *Oikos* 53:126–135
- Kautsky L (1990) Seed and tuber banks of aquatic macrophytes in the Askö area, northern Baltic proper. *Holarct Ecol* 13:143–148
- Kautsky L (1991) *In situ* experiments on the interrelationships between six brackish macrophyte species. *Aquat Bot* 39:159–172
- Kautsky L, Kautsky N (2000) The Baltic Sea, including Bothnian Sea and Bothnian Bay. In: Sheppard CRC (ed) *Seas at the millennium: an environmental evaluation*, Vol I. Regional chapters: Europe, The Americas and West Africa. Elsevier Science, Oxford, p 121–134
- Kristensen E, Andersen FØ (1987) Determination of organic carbon in marine sediments: a comparison of two CHN-analyzer methods. *J Exp Mar Biol Ecol* 109:15–23
- Kristensen E, Hansen K (1995) Decay of plant detritus in organic-poor marine sediment: production rates and stoichiometry of dissolved C and N compounds. *J Mar Res* 53:675–702
- Loreau M (1998) Separating sampling and other effects in biodiversity experiments. *Oikos* 82:600–602

- Loreau M (2000) Biodiversity and ecosystem functioning: recent theoretical advances. *Oikos* 91:3–17
- Loreau M, Hector A (2001) Partitioning selection and complementarity in biodiversity experiments. *Nature* 412:72–76
- Loreau M, Naeem S, Inchausti P, Bengtsson J and others (2001) Biodiversity and ecosystem functioning: current knowledge and future challenges. *Ecology* 294:804–808
- Lorentzen S, Roscher C, Schumacher J, Schulze ED, Schmid B (2008) Species richness and identity affect the use of aboveground space in experimental grasslands. *Perspect Plant Ecol Evol Syst* 10:73–87
- Moore TN, Fairweather PG (2006) Decay of multiple species of seagrass detritus is dominated by species identity, with an important influence of mixing litters. *Oikos* 114: 329–337
- Naeem S, Håkansson K, Lawton JH, Crawley MJ, Thompson LJ (1996) Biodiversity and plant productivity in a model assemblage of plant species. *Oikos* 76:259–264
- Orth RJ, Carruthers TJB, Dennison WC, Duarte CM and others (2006) A global crisis for seagrass ecosystems. *BioScience* 56:987–996
- Parker JD, Duffy JE, Orth RJ (2001) Plant species diversity and composition: experimental effects on marine epifaunal assemblages. *Mar Ecol Prog Ser* 224:55–67
- Roscher C, Schumacher J, Weisser WW, Schmid B, Schulze ED (2007) Detecting the role of individual species for overyielding in experimental grassland communities composed of potentially dominant species. *Oecologia* 154: 535–549
- Santamaría L, Llano García AI (2004) Latitudinal variation in tuber production in an aquatic pseudo-annual plant, *Potamogeton pectinatus*. *Aquat Bot* 79:51–64
- Short FT (1987) Effects of sediment nutrients on seagrasses: literature review and mesocosm experiment. *Aquat Bot* 27:41–57
- Sokal RR, Rohlf FJ (1994) *Biometry: the principles and practice of statistics in biological research*, 3rd edn. W. H. Freeman, New York
- Solan M, Raffaelli DG, Paterson DM, White PCL, Pierce GJ (2006) Marine biodiversity and ecosystem function: empirical approaches and future research needs. *Mar Ecol Prog Ser* 311:175–178
- Srivastava DS, Vellend M (2005) Biodiversity-ecosystem function research: Is it relevant to conservation? *Annu Rev Ecol Evol Syst* 36:267–294
- Stachowicz JJ, Bruno JF, Duffy JE (2007) Understanding effects of marine biodiversity on communities and ecosystems. *Annu Rev Ecol Evol Syst* 38:739–766
- Tilman D (1999) The ecological consequences of changes in biodiversity: a search for general principles. *Ecology* 80: 1455–1474
- Tilman D, Knops D, Wedin P, Reich M, Ritchie M, Sieman E (1997) The influence of functional diversity and composition on ecosystem processes. *Science* 277:1300–1302
- van Ruijven J, Berendse F (2005) Diversity-productivity relationships: initial effects, long-term patterns, and underlying mechanisms. *Proc Natl Acad Sci USA* 102:695–700
- Weigelt A, Schumacher J, Walther T, Bartelheimer M, Steinlein T, Beyschlag W (2007) Identifying mechanisms of competition in multispecies communities. *J Ecol* 95:53–64
- Williams SL (1990) Experimental studies of Caribbean seagrass bed development. *Ecol Monogr* 60:449–469
- Wolfer SR (2008) Clonal architecture and patch formation of *Potamogeton perfoliatus* L. in response to environmental conditions. PhD thesis, Wageningen University, Wageningen
- Wolfer SR, Straile D (2004) Spatio-temporal dynamics and plasticity of clonal architecture in *Potamogeton perfoliatus*. *Aquat Bot* 78:307–318
- Worm B, Reusch TBH (2000) Do nutrient availability and plant density limit seagrass colonization in the Baltic Sea? *Mar Ecol Prog Ser* 200:159–166

Submitted: May 5, 2009; Accepted: September 17, 2009

Proofs received from author(s): November 27, 2009



Relative importance of biodiversity and the abiotic environment in mediating an ecosystem process

J. A. Godbold*, M. Solan

Oceanlab, Institute of Biological and Environmental Sciences, University of Aberdeen, Newburgh,
Aberdeenshire AB41 6AA, UK

ABSTRACT: Whilst there is a wealth of empirical studies that indicate negative ecosystem consequences of biodiversity loss, much debate remains over the existence, strength and importance of the same patterns in natural systems. We used a gradient of organic enrichment as a means of defining non-random species loss in the marine benthos and, using partial linear regression, determined the relative importance of macrofaunal biodiversity and the abiotic environment in affecting a benthic ecosystem process (bioturbation intensity; indicated by sediment mixing depth), that is important in mediating benthic functioning. Of the abiotic and biotic variables tested ($n = 8$), species richness and sediment total organic carbon (TOC) content together explained 65 % of the variability in this ecosystem process, with more than half of this variability explained solely by species richness. Importantly, the relative importance of biodiversity decreased at low levels of species richness and/or high levels of TOC. These results have profound implications for manipulative field experiments, where environmental factors are likely to dominate ecosystem processes, because the extent and importance of biological mediation could be underestimated. Our results also revealed that a large proportion of the explained variability in the ecosystem process is explained by the underlying reciprocal relationship (shared variability) between biodiversity and sediment TOC, highlighting the importance of species–environment interactions. If we are to fully appreciate the role of biodiversity in natural systems, our findings suggest that the intimate relationship between species and their environment needs to be more prominently featured in future studies that consider the ecosystem consequences of biodiversity loss.

KEY WORDS: Biodiversity · Ecosystem processes · Species richness · Ecosystem functioning · Partial linear regression · Gradient

Resale or republication not permitted without written consent of the publisher

INTRODUCTION

The effects of biodiversity loss on ecosystem processes have now been well established and numerous experimental studies have shown that, irrespective of the system under study, biodiversity loss has a negative effect on ecosystem properties (Balvanera et al. 2006, Cardinale et al. 2006, Worm et al. 2006). There has been much debate and controversy over how realistic the experimental approach for investigating the relationship between biodiversity and ecosystem processes is, due to the highly controlled conditions of the mesocosm environment and the simplifying assumption that species loss is random (e.g. Hooper et al. 2005, Srivastava & Vellend 2005). Despite the fact that

researchers have steadily improved designs to make experimental studies more closely resemble natural systems (see Fig. 1.3 in Godbold 2008, Naeem 2008, Solan et al. 2009), there is a fundamental difference between being able to demonstrate biodiversity effects under assembled conditions and showing that such effects are just as strong and important in natural systems (Srivastava & Vellend 2005). Observational studies, in which correlations between regional gradients in biodiversity and ecosystem processes are performed (e.g. McNaughton 1993, Wardle et al. 1997), have been valuable in this regard, but direct cause–effect relationships cannot generally be determined because covarying environmental factors (e.g. temperature, soil fertility, rainfall, area, fire frequency) may also affect

*Email: j.a.godbold@abdn.ac.uk

ecosystem processes (Tilman et al. 1997, Grace et al. 2007). A further complication is the debate over whether diversity is the cause or consequence of ecosystem functioning (Flint & Kalke 2005, Cardinale et al. 2009). Consequently, although there is a long tradition in ecology of recognising that abiotic factors can significantly affect ecosystem functioning (e.g. primary production, Botkin & Malone 1968), few attempts have been made to determine the relative importance of biodiversity and environmental factors in affecting ecosystem properties in natural systems (but see Grace et al. 2007, Healy et al. 2008) because these ecosystems are structured by multiple and simultaneously operating abiotic and biotic factors that are difficult to dissociate (Angermeier & Winston 1998). Nonetheless, overcoming these difficulties is an essential step in fully understanding the consequences of altered diversity in natural systems where the role of diversity has likely been understated (Duffy 2009).

Accounting for the effects of (multi)collinearity between explanatory variables and/or spatial autocorrelation between sampling points is not trivial (but see e.g. Galbraith et al. 2008, Jones et al. 2008). Even low amounts of collinearity can bias analyses (Graham 2003), causing inaccurate model parameterisation and decreased statistical power that can lead to ambiguous interpretations of the underlying relationships (Legendre 1993, Legendre & Legendre 1998, MacNally 2000, Graham 2003). In addition, (multi)collinearity between explanatory variables may result in ecologically more plausible explanatory variables being excluded from, for example, a stepwise multiple regression analysis, if other correlated explanatory variables statistically better explain the observed variability in the response variable (MacNally 2000, Graham 2003). Several approaches can be adopted to overcome problems of collinearity within data from natural systems (e.g. Graham 2003). These range from the exclusion of some of the most collinear variables to using statistical techniques such as variation partitioning (canonical correspondence analysis, Borcard et al. 1992; partial linear regression, Legendre 1993), hierarchical partitioning (Chevan & Sutherland 1991, Mac Nally 2000), principal components regression (Jolliffe 2002) or structural equation modelling (Grace 2006), but these techniques have seldom been applied within the biodiversity–ecosystem functioning framework.

Despite the statistical and interpretational drawbacks of investigating natural ecological systems, the use of anthropogenic and natural gradients has been vital for improving our understanding of long-term community and ecosystem dynamics (for review see Fukami & Wardle 2005). For example, the use of elevation gradients has improved our understanding of the effects of global warming on ecosystem processes such as soil de-

composition and nutrient mineralisation (Vitousek et al. 1994). Similarly, CO₂ gradients from natural springs have been used to illustrate the long-term effects of CO₂ enrichment on the ecosystem storage of carbon and nitrogen (e.g. Ross et al. 2000). Such observational studies, in which the number of confounding factors that may influence ecosystem properties are limited (e.g. Vitousek et al. 1994, Troumbis & Memtsas 2000), are of vital importance, as long as their limitations are explicitly recognised, because they can allow causal relationships to be inferred (Fukami & Wardle 2005). Indeed, natural gradients of species diversity have been used to infer how species loss may affect ecosystem functioning, in particular productivity, although confounding factors have not always been constrained (but see Troumbis & Memtsas 2000, Thompson et al. 2005) and, consequently, results have been variable. Some studies suggest a generally positive relationship between plant diversity and productivity (Troumbis & Memtsas 2000, Mittelbach et al. 2001), whilst others find no such effect and instead suggest that abiotic factors are more important in natural systems (Wardle et al. 1997, Thompson et al. 2005). Indeed, some (e.g. Huston & McBride 2002) have argued that productivity is regulated first and foremost by environmental conditions, such as climate and soil composition, and that these make diversity effects so subtle that they can only be detected under highly controlled experimental conditions in which the influence of the environment has been excluded or controlled. Moreover, the scales at which ecosystem processes occur can be radically different to the spatial and temporal scales at which biodiversity operates (Raffaelli 2006). This would suggest that biodiversity effects are unlikely to be detected in natural systems, especially at the regional or global scale (but see Hector et al. 1999, Emmerson et al. 2001), because the variability of any environmental variables outweighs the mediating effects of the biota.

There are instances, however, where environmental variability becomes more predictable and directional, such as along natural and anthropogenic gradients of disturbance. These gradients have been particularly well studied in marine benthic environments, where sequential changes in community composition have been documented alongside concurrent changes in the physicochemical properties of the benthos (e.g. Pearson & Rosenberg 1978, Rhoads et al. 1978). Although organic enrichment provides a supplementary food source for benthic invertebrate fauna, excessive enrichment can cause significant negative shifts in sediment chemistry and benthic community diversity as oxygen becomes depleted (for review see Diaz & Rosenberg 2008). However, the relative importance of the respective pathways of organic matter degradation are also influenced by the burrowing and irrigation activities of

the fauna which transport oxygenated water into the sediment profile, thereby enhancing decomposition and the regeneration of nutrients essential for primary productivity (Kristensen et al. 1995). Along these gradients, the depth of oxidised sediments is frequently used as an indicator of net benthic functioning (mixing depth [MD]; Solan et al. 2004a), providing an opportunity to distinguish the relative importance of biodiversity from environmental factors on ecosystem processes.

In the present study, we characterised changes in benthic community composition and sediment parameters associated with a gradient of organic enrichment from a Scottish fish farm and then determined the most important biotic and abiotic variables in mediating the MD along this gradient. Using variance partitioning (Legendre 1993), we used these data to distinguish the relative importance of changes in macrofaunal diversity from the effects of the abiotic environment in mediating a benthic ecosystem process.

MATERIALS AND METHODS

Faunal sampling and sediment collection. Sampling was conducted in Loch Creran, Scotland, along an organic enrichment gradient related to commercial fish aquaculture (salmon *Salmo salar*). To characterise the environmental gradient, sediment and macrofaunal samples were collected using a multi-corer from the RV 'Calanus' along a transect of 7 stations (~50 m apart) away from the area of the fish farm in the direction of the prevailing tidal current. To avoid pseudoreplication, 2 undisturbed cores from each of 5 deployments (internal diameter = 100 mm, depth = 100 mm) were used from each station; one for sediment analyses and the other for macrofaunal identification. For analyses of the sediment parameters, the surface sediment (0 to 2 cm) was retained from each core (n = 35) and frozen at -20°C. The cores for determination of the macrofaunal communities were immediately sieved (500 µm). All fauna retained within the sieve were regarded as macrofauna and were fixed in a 10% formalin (4% formaldehyde) solution buffered with Borax (magnesium borate) to which a 1% Rose Bengal stain was added to aid visual location of the fauna during sorting.

Sediment profile imaging. The depth of oxidised sediments (MD) is affected by a combination of abiotic and biotic factors and is frequently used as an indicator of net benthic functioning (Solan et al. 2004a) that is related to the richness, abundance and biomass of fauna (e.g. Pearson & Rosenberg 1978) as well as the rate of organic matter decomposition and nutrient regeneration (Kristensen 2000). The MD can be quantified (for review see Teal et al. 2008) using sediment profile imaging (SPI), a standard technique for deter-

mining organism-sediment interactions in relation to benthic disturbances (Rhoads & Germano 1986). An SPI camera was deployed from the RV 'Seol Mara' along the transect to obtain replicate (n = 5) sediment profile images (18.75 × 28.13 cm, 3000 × 4500 pixels) from each site (n = 7).

Standard image analysis techniques were used to quantify the depth of the MD. Sediment profile images were saved in RGB colour with jpeg compression and analysed using a custom-made, semi-automated macro that runs within ImageJ (Version 1.40), a java-based public domain program (available at <http://rsb.info.nih.gov/ij/index.html>). The green slice of the image is most suitable for visual discrimination of the sediment-water interface, which was manually traced with the segmented line tool. The segmented line represented the upper limit of the region of interest for the subsequent analyses. The red slice of the image was then used to distinguish the oxidised (high reflectance) from the reduced (low reflectance) sediment, by manually setting the appropriate threshold for each image (Solan et al. 2004b), and the total area (cm²) and mean depth (cm) of the MD were automatically calculated.

Macrofaunal identification, enumeration and biomass determination. Following preservation with formaldehyde, all macrofauna samples were stored in sealed jars and plastic buckets at ambient temperature in the dark to allow the biomass to stabilise. All taxa were identified to the lowest possible taxon (60.75% species, 10.28% genus, 9.35% family, 19.63% other).

For the estimation of biomass, the fauna were blotted dry with absorbent paper to remove excess liquid before wet weight determination (g, Ohaus Adventurer Pro 5-figure balance). All tube-dwelling worms (e.g. *Owenia fusiformes*, *Melinna palmata*) and hermit crabs *Anapagurus laevis* were removed from their tubes and shells, respectively, prior to weighing. Due to their small sizes, all bivalves and gastropods were weighed including their shells. For each replicate core the total abundance and total biomass is expressed as per m² equivalents.

Sediment characteristics. Sediment particle size (mean particle size in µm) was determined optically using a Malvern Mastersizer X He-Ne LASER diffraction particle sizer (Malvern Instruments) from 5 g wet weight of surface sediment (n = 5 per station). To establish the quality of the organic material along the gradient, total nitrogen and carbon concentrations were determined using 0.22 ± 0.02 g of dried, ground sediment using a Fisons NA 1500 NCS-Analyser (Fisons Instruments) (Allen 1989). In addition, the total organic carbon concentration (TOC, %) of the sediment was determined by loss on ignition of 1.05 ± 0.01 g of dry sediment after combustion for 1 h at 525°C. Further, we determined total phosphorus (TP,

mg g⁻¹) and total copper (TCu, mg g⁻¹) concentrations of the surface sediments using a sulphuric acid/hydrogen peroxide digestion of 0.1 ± 0.001 g dried ground sediment. TP concentration of the acid digest was determined colorimetrically using a flow injection auto-analyser (FIA Star 5010 with a 5023 spectrophotometer, Tecator) at a detection wavelength of 690 nm. TCu concentration was determined by atomic absorption spectrometry (Perkin Elmer AAnalyst 100) at a detection wavelength of 324.8 nm (Allen 1989).

Statistical analyses. A multiple-linear regression model was developed to determine the relative effects of abiotic and biotic variables on the MD along the gradient of impact. The abiotic explanatory variables included TOC, C:N, mean grain size diameter, TP and TCu and station, whilst the biotic explanatory variables were species richness, abundance (ind. m⁻²) and biomass (g m⁻²). In order to reduce the spread in data within the biotic explanatory variables, abundance and biomass were log_e- and square root-transformed, respectively. In addition, the abiotic explanatory variables (TOC, grain size, TP and TCu) were standardised (z-scores) by centering each variable around its mean across the gradient and dividing by the standard deviation. Standardisation of the variables in this way eliminates size differences between explanatory variables and reduces their variability to a common scale (Legendre & Legendre 1998, Gelman & Hill 2007). All explanatory variables, except for station, were included as continuous variables in the initial model, which contained only single terms. The variable station was included as a nominal explanatory variable (n = 7). Interactions were not included in the model at this stage, as the sample size relative to the number of explanatory variables was insufficient (see Gelman & Hill 2007).

Graphical exploratory techniques were used to check for outliers, normality and collinearity of data prior to analysis. Normality was determined by plotting the theoretical quantiles versus the standardised residuals (Q–Q plots) and homogeneity of variance was evaluated by plotting the residuals versus the fitted values. Collinearity was assessed by plotting a scatter plot matrix with associated correlation coefficients, as well as by calculating the variance inflation factor (VIF) for each explanatory variable (Quinn & Keough 2002). Removal of explanatory variables was based on a conservative level of collinearity (Pearson's correlation coefficient $r > 0.6$ and $VIF > 5$). Species richness and station were strongly collinear ($r = 0.91$) (Fig. S1 in the supplement, available as MEPS Supplementary Material at: www.int-res.com/articles/suppl/m396p273_app.pdf). As our focus was to determine the importance of biodiversity on MD, we retained species richness but removed station from the analysis (MacNally 2000). The VIF value for species richness ($VIF = 5.52$) and the scat-

ter plot matrix (Fig. S2 in the supplement) further indicated that species richness was also collinear with other explanatory variables (biomass, TCu, TP). The removal of species richness as an explanatory variable, however, was not appropriate, as doing so would negatively affect the residual pattern of the linear regression model. Therefore, biomass, TCu and TP were removed from the analysis. An influential data point (n = 1, Stn 2) that unduly influenced the estimated regression parameters (slope and intercept) was identified using *dfbeta* and Cook's distance and was removed (Fox 2002, Quinn & Keough 2002). A reanalysis with 100% of the data did not alter the conclusions of the present study, but resulted in a weaker model. Violation of independence of the residuals through spatial autocorrelation between sampling stations was investigated using a bubble plot in which the residuals of the model are plotted against the spatial coordinates of the stations (Zuur et al. 2009). The minimal adequate model was determined using a stepwise backward model selection procedure on a model that included all of the remaining explanatory variables (species richness, abundance, TOC, C:N) as single terms. Model selection was based on Akaike's information criterion (AIC) (Quinn & Keough 2002) and validated by visual inspection of plots of residuals versus fitted values. This procedure is known to perform similarly to other exhaustive algorithms for subset selection (Murtaugh 2009) and retained species richness and TOC as explanatory variables. Nevertheless, in order to ensure that the selection procedure was robust, we confirmed selection using hierarchical partitioning (Fig. S3 in the supplement), Mallows's C_p (Fig. S4 in the supplement) and adjusted r^2 (Table S1 in the supplement) (Draper & Smith 1998, Quinn & Keough 2002). The presence of interactive effects between species richness and TOC on the MD was investigated using a co-plot and the interaction was subsequently included in the model. Thus, the minimal adequate model best describing how and which variables mediate the MD consisted of the factors species richness and TOC as single terms and also included the interaction species richness × TOC.

In order to partition the effects of species richness from the effect of TOC on MD, a partial linear regression analysis was used (Legendre 1993, Legendre & Legendre 1998). Partial linear regression allows estimation of how much of the variation in MD can be exclusively attributed to species richness and TOC. However, this procedure assumes that effects are additive and therefore the interaction (species richness × TOC) was removed from the minimal adequate model. The amount of variation attributed to either explanatory variable is determined by regressing each explanatory variable against the response variable in the absence of the other explanatory variable. Using

the procedures detailed in Legendre & Legendre (1998), the total variation in MD is thus partitioned into the following components: (1) the variance explained by species richness alone, (2) the variance explained by TOC alone, (3) the amount of shared variance explained by species richness and TOC and (4) the amount of unexplained variation.

All analyses were performed using the 'hier.part' (Walsh & Mac Nally 2008), 'wle' (Agostinelli 2006) and 'nlme' (Pinheiro et al. 2009) packages in the 'R' statistical and programming environment (R Development Core Team 2007). Data are presented as means \pm SD unless otherwise indicated.

RESULTS

Description of the biotic and abiotic gradient

The mean MD progressively decreased along the gradient from 6.1 ± 0.6 cm at Stn 1 furthest away from the fish farm to 2.9 ± 0.5 cm at Stn 7 at the fish farm (Fig. 1, Fig. S5 in the supplement for sediment profile images). Sediment TOC, C:N, TP and TCu content increased, whilst sediment grain size decreased from Stn 1 to 7 (Fig. 2). The mean TOC content of the sediment increased from $6.7 \pm 1.5\%$ (Stn 1) to $19.4 \pm 5.0\%$ (Stn 7), whilst the mean TP content increased from $1.6 \pm 0.1 \text{ mg g}^{-1}$ (Stn 1) to $13.6 \pm 3.8 \text{ mg g}^{-1}$ (Stn 7) and the mean TCu content increased from $0.02 \pm 0.004 \text{ mg g}^{-1}$ (Stn 1) to $0.30 \pm 0.012 \text{ mg g}^{-1}$ (Stn 7)

(Stn 7). The increase in TOC coincided with an overall reduction in sediment quality (higher C:N) along the gradient and a decrease in the mean particle size from $79.28 \pm 4.4 \mu\text{m}$ at Stn 1 to $29.3 \pm 10.7 \mu\text{m}$ at Stn 6.

Along the environmental gradient, there were distinct changes in benthic macrofaunal species composition, abundance and biomass (Fig. 3). Species richness

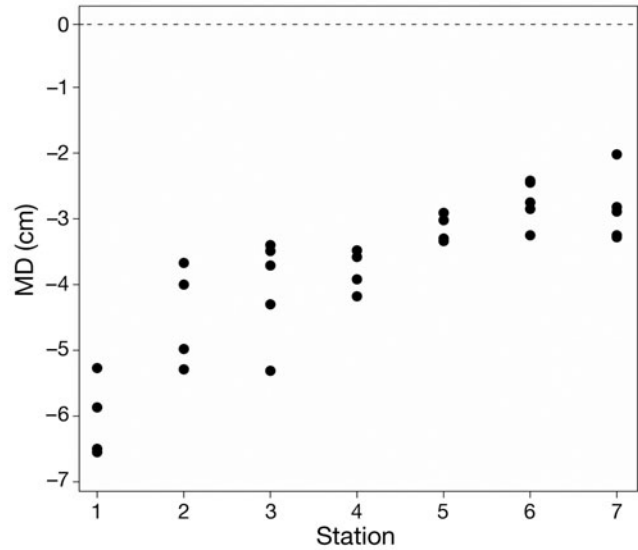

Fig. 1. Mixing depth (MD, cm) at each station along the enrichment gradient, with Stn 1 being furthest away from the fish farm and Stn 7 at the fish farm. Negative values correspond to increasing MD and the dotted line represents the sediment–water interface

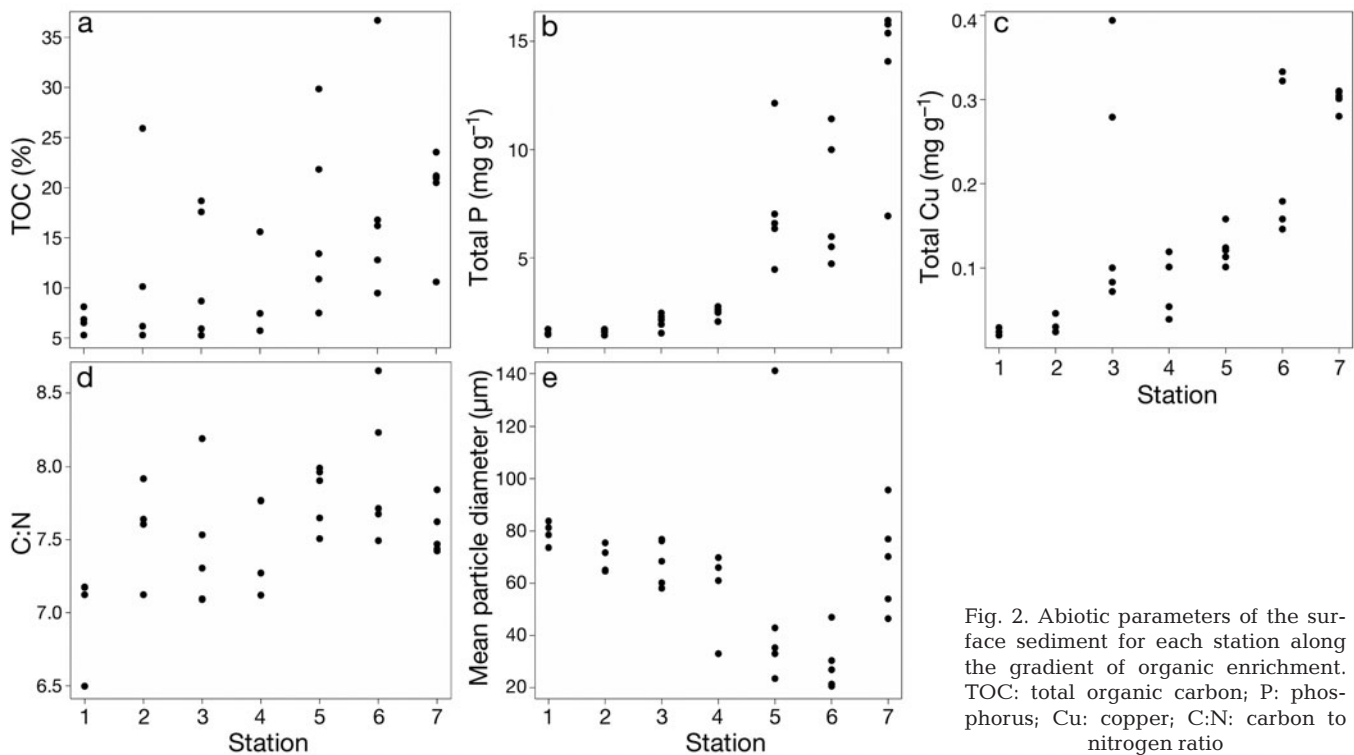

Fig. 2. Abiotic parameters of the surface sediment for each station along the gradient of organic enrichment. TOC: total organic carbon; P: phosphorus; Cu: copper; C:N: carbon to nitrogen ratio

decreased from 30 ± 4 species at Stn 1 to 6 ± 3 species at Stn 7 (Fig. 4a). Mean species abundance ($n = 5$) was lowest at Stn 3 (7028.3 ± 916.7 ind. m^{-2}) and highest at Stn 1 ($16\,042.8 \pm 5074.6$ ind. m^{-2}) (Fig. 4b). In terms of abundance, Stns 5–7 were dominated by the polychaetes *Eunicidae* spp., *Capitella capitata* (Capitellidae), *Heteromastus filiformis* (Capitellidae) and *Malacoceros fuliginosus* (Spionidae), whilst Stns 1 and 2 were dominated by the mollusc *Mysella bidentata* (Bivalvia) and the polychaetes *Prionospio flallax* (Spionidae) and *Melinna palmata* (Ampharetidae). At Stn 3 the faunal assemblage was dominated by *H. filiformis*, an unidentified nemertean and *M. bidentata*, whilst Stn 4 was dominated by the polychaetes *C. capitata* and *H. filiformis* as well as the same unidentified nemertean as at Stn 3.

Mean total faunal biomass ($n = 5$) was highest at Stn 1 (226.9 ± 198.8 g m^{-2}) and lowest at Stn 5 ($9.6 \pm$

5.6 g m^{-2}), increasing to 102.8 ± 211.2 g m^{-2} at Stn 7 (Fig. 4c). The mollusc *Philine aperta* (Philinidae) and the polychaete *Notomastus latericeus* (Capitellidae) were dominant species in terms of biomass at the majority of stations along the gradient, exceeding 40 g m^{-2} at Stns 2, 3 and 4 for *P. aperta* and Stn 3 for *N. latericeus*. Stns 1 and 2 were associated with a high biomass of the anthozoans *Pennatula phosphorea* (Pennatulidae, Stn 1) and *Virgularia mirabilis* (Virgulariidae, Stn 2), the echinoderm *Amphiura filiformis* (Amphiuridae) as well as the polychaete *Melinna palmata*. Stn 3 was dominated by *N. latericeus*, *P. aperta* and *Terebellides stroemi* (Terebellidae), whilst at Stns 4 and 5 *P. aperta* was the dominant species. Stns 6 and 7 were dominated by the polychaetes *Neanthes (Nereis) irrorata* (Nereidae) and *Malacoceros fuliginosus* (Spionidae).

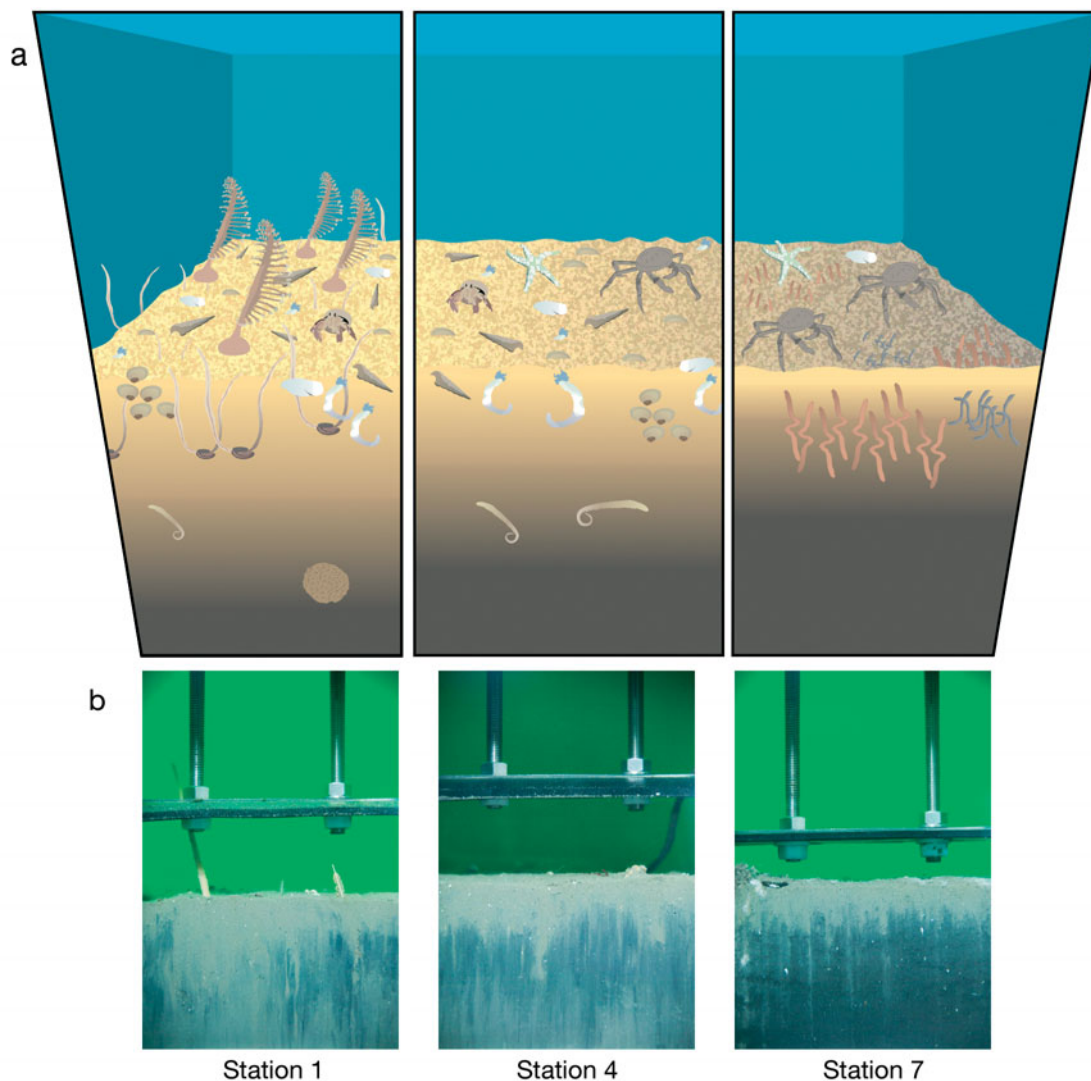

Fig. 3. (a) Schematic representation of the changes observed in macrofaunal community composition with increasing organic enrichment and (b) corresponding sediment profile images at Stns 1, 4 and 7. Note that the mixing depth (light brown sediment) and macrofaunal diversity decrease with proximity to the fish farm (Stn 7). In (b) image width = 18.75 cm

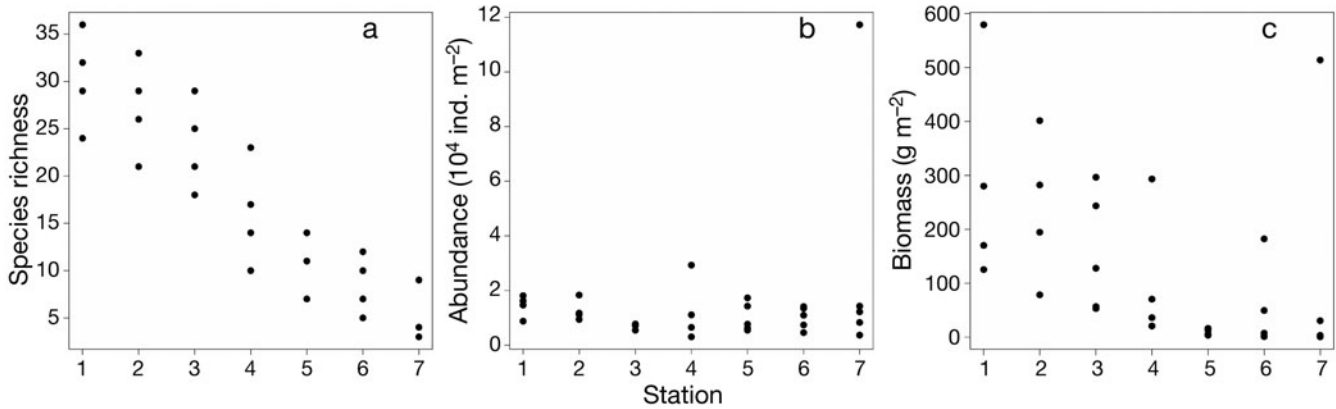

Fig. 4. Summary of macrofaunal returns from 5 replicate cores expressed as (a) species richness, (b) abundance and (c) biomass for each station along the gradient of increasing organic enrichment

Effects of the biotic and abiotic environment on MD

The minimal adequate model was a linear regression containing species richness ($F = 58.70$, $df = 1$, $p < 0.0001$), TOC ($F = 5.00$, $df = 1$, $p < 0.05$) and the interaction species richness \times TOC ($F = 7.37$, $df = 1$, $p < 0.05$) and explained 72% of the total variation in MD ($F = 23.69$, $df = 27$, $p < 0.0001$). At low levels of TOC (for standardised TOC < 0 , Fig. 5) the MD increased strongly with species richness. As TOC concentration increased (for standardised TOC > 0 , Fig. 5), the effect of high species diversity on MD decreased. Overall, there was a positive effect of species richness on MD in all but the most enriched stations (for standardised TOC > 2.0).

Partitioning the effects of the biotic and abiotic environment on MD

Species richness and TOC, as main terms, together explained 64.96% of the total variability in MD ($F = 25.95$, $df = 28$, $p < 0.0001$). MD increased with species richness (coefficient \pm SE = 0.08 ± 0.02 , $t = 5.192$, $p < 0.0001$), whilst TOC had a marginal negative effect on MD (coefficient \pm SE = -0.03 ± 0.15 , $t = -2.019$, $p = 0.053$). Partial linear regression revealed that over half of the explained variation in MD was attributed to species richness (33.74% of total variation), whilst 5.1% of the total variation was attributed purely to TOC. Less than half (26.12% of total variation) of the explained variation in MD was shared between species richness and TOC. Overall, 35.04% of the total variation in MD could not be explained by species richness or TOC (Fig. 6).

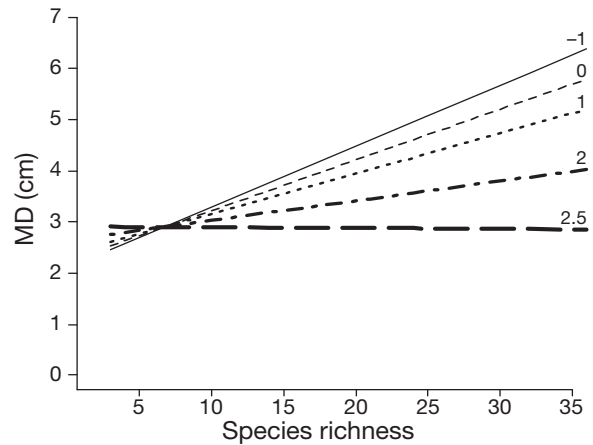

Fig. 5. Effect of species richness and total organic carbon (TOC) on mixing depth (MD, cm). The lines represent model predictions of the interaction species richness \times TOC for different levels of TOC centered on the mean across the gradient (mean = 0, negative represents lower than mean TOC content and positive represents higher than mean TOC content). MD = 0 represents the sediment–water interface

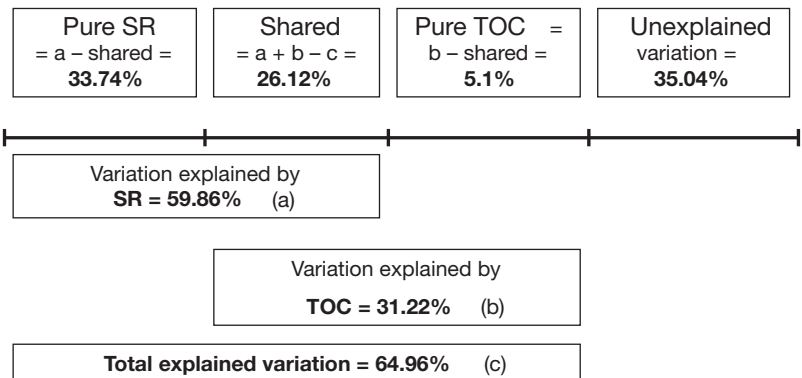

Fig. 6. Graphical summary of the partitioning of the variability in MD among the explanatory variables species richness (SR) and total organic carbon (TOC, %). Percentages represent the R^2 from the partial linear regression models. Adapted from Legendre & Legendre (1998)

DISCUSSION

The present study has successfully documented changes in macrofaunal community composition, physicochemical sediment characteristics and net benthic ecosystem functioning that were associated with an anthropogenic gradient of disturbance. The observed patterns are consistent with what would be expected from benthic successional paradigms (Pearson & Rosenberg 1978, Rhoads et al. 1978), with the number of species and organic carbon input being the most important factors affecting the MD. Despite the presence of a natural covariance between shifts in community structure and changing environmental factors, the relative importance of TOC and species richness, and their shared contribution, in affecting ecosystem functioning have been determined and together explain the majority (65%) of the variability in MD.

In contrast to previous studies (e.g. Grace et al. 2007, Healy et al. 2008), changes in species richness accounted for 34% of the total variability in an ecosystem process (here, MD), whilst environmental factors (here, TOC) had a much lower explanatory power, contributing to only 5% of the total variability, despite the presence of a strong organic enrichment gradient. The relative weighting of these findings contradict numerous observational studies that suggest that ecosystem functioning will be influenced more by abiotic conditions than by species diversity (e.g. Wardle et al. 1997, Thompson et al. 2005, Grace et al. 2007). Empirical studies, however, have demonstrated that the magnitude of species richness effects may be dependent upon how species interact with the environment; plant species mixtures only have a positive effect on ecosystem functioning if, for example, environmental conditions (e.g. light and soil fertility) allow for mechanisms such as resource partitioning (e.g. Fridley 2002). Such modifying effects of environmental conditions on the relationship between biodiversity and ecosystem functioning have, in the past, largely been attributed to changes in the behaviour and/or relative dominance of individuals within an assemblage (e.g. Cardinale et al. 2000, Bulling et al. 2008, Healy et al. 2008).

A cursory examination of the results of the present study would suggest that enhanced species richness is only important for ecosystem functioning at low levels of organic enrichment, presumably because the environment is less hostile and contains higher species diversity. Yet our model predictions suggest that even at elevated levels of organic enrichment species richness is still of fundamental importance in positively affecting ecosystem functioning. Only at very high levels of organic enrichment, or at low levels of species richness (<10), do environmental drivers become more

important in modifying ecosystem processes. If these effects are widespread, such findings have profound implications for field experiments in which diversity is directly manipulated and the species used represent only a subset of the total community (Bulling et al. 2006), because environmental factors are likely to have a stronger effect on ecosystem processes than biodiversity. In fact, meta-analyses provide supporting evidence that species diversity effects tend to be weaker in experimental systems with low levels of diversity (<10 species as the highest diversity level) and in less well-controlled systems (Balvanera et al. 2006), where other environmental factors are likely to be contributing to ecosystem properties (Balvanera et al. 2006, Romanuk et al. 2009). Many *in situ* experiments that have manipulated species diversity and acknowledged the potential effects of environmental factors often assert that abiotic effects (litter quality and temperature, Lecerf et al. 2007; environmental heterogeneity, Healy et al. 2008; nutrient availability, Godbold et al. 2009) are likely to be stronger determinants of ecosystem processes than species diversity.

The present study is the first to quantitatively document, in a natural system and in the presence of a gradient of non-random species loss, that the importance of abiotic influences on an ecosystem process decreases as the full suite of biodiversity is realised. The absolute importance of species diversity in maintaining ecosystem functioning is related to functional characteristics, such as body size, sediment reworking mode and mobility, and how these relate to an individual species' risk of extinction (Solan et al. 2004a). The loss (or decrease in abundance) of species associated with increased organic enrichment and sediment anoxia tends to include those species which have the strongest effects on sediment particle redistribution and porewater chemistry (Diaz & Rosenberg 2008). This is because, in the absence (or reduction in abundance) of these key bioturbating and bioirrigating species, oxygen penetration is limited and microbes begin to utilise other less efficient electron acceptors (e.g. NO_3^- , SO_4^{2-} , MnO_4 , FeOH and CO_2). These are reduced to metabolites (N_2 , HS^- , Mn^{2+} , Fe^{2+} and CH_4 , respectively) which can be highly toxic to benthic fauna, leading to further reductions in the abundance and richness of deeper dwelling bioturbators (Aller 1994). Here, the most susceptible species to the effects of enhanced organic enrichment are also those species with traits that are important for bioturbation and bioirrigation (Solan et al. 2004a), including the echinoderm *Amphiura filiformis*, the bivalves *Mysella bidentata* and *Thyasira flexulosa* as well as the tubedwelling or burrowing polychaetes *Melinna palmata*, *Magelona filiformis*, *Leitoscoloplos mammosus* and *Lumbrineris tetaura*. Even substantial increases in

abundance ($>15\,000$ ind. m^{-2}) of *Capitella* sp., which have smaller body sizes and have less impact on the redistribution of particles and/or porewater fluids, cannot compensate for the loss of larger bioturbating species because the negative effects of the organic enrichment on sediment chemistry outweigh the effects of the surviving species on the mixing depth. This underlying reciprocal relationship between the abiotic and biotic components of the system (Hughes et al. 2007) accounts for almost half of the explained variability in an ecosystem process, but is rarely incorporated into experimental designs (e.g. Bulling et al. 2008). Although the relevance and applicability of biodiversity–ecosystem functioning studies has improved by incorporating environmental realism (Godbold 2008, Naeem 2008, Solan et al. 2009), it is clear that the next generation of biodiversity experiments needs to explicitly incorporate, rather than control for, the reciprocal relationship between biodiversity and the environment. A greater appreciation of the interdependencies between biodiversity and environmental change (e.g. Hiscock et al. 2004) is an immediate requirement if we are to further our understanding of the ecosystem consequences of biodiversity loss in natural systems.

Acknowledgements. We thank the captain and crew of the RVs 'Calanus' and 'Seol Mara' from the Scottish Association for Marine Science, A. Jamieson and D. Mayor (Oceanlab, University of Aberdeen) for deployment of the SPI camera and R. Kennedy (Martin Ryan Institute, National University of Ireland, Galway) for the sediment particle size analysis. We are also grateful to C. Lee (Medical Illustration, University of Aberdeen) for production of the graphics used to visualise macrofaunal community composition. This work was part funded by a Natural Environment Research Council studentship grant (NER/S/A/1005/13734) to J.A.G. and the EU framework 6 programme entitled Coastal Ocean Benthic Observatories.

LITERATURE CITED

- Agostinelli C (2006) wle: weighted likelihood estimation. Available at www.stats.bris.ac.uk/R/
- Allen SE (1989) Chemical analysis of ecological materials, 2nd edn. Blackwell Scientific Publications, Oxford
- Aller RC (1994) Bioturbation and remineralisation of sedimentary organic matter: effects of redox oscillation. *Chem Geol* 114:331–345
- Angermeier PL, Winston MR (1998) Local vs. regional influences on local diversity in stream fish communities of Virginia. *Ecology* 79:911–927
- Balvanera P, Pfisterer AB, Buchmann N, He JS, Nakashizuka T, Raffaelli D, Schmid B (2006) Quantifying the evidence for biodiversity effects on ecosystem functioning and services. *Ecol Lett* 9:1146–1156
- Borcard D, Legendre P, Drapeau P (1992) Partialling out the spatial component of ecological variation. *Ecology* 73:1045–1055
- Botkin DB, Malone CR (1968) Efficiency of net primary production based on light intercepted during the growing season. *Ecology* 49:438–444
- Bulling MT, White PCL, Raffaelli D, Pierce GJ (2006) Using model systems to address the biodiversity–ecosystem functioning process. *Mar Ecol Prog Ser* 311:295–309
- Bulling MT, Solan M, Dyson KE, Hernandez-Milian G and others (2008) Species effects on ecosystem processes are modified by faunal responses to habitat composition. *Oecologia* 158:511–520
- Cardinale BJ, Nelson K, Palmer MA (2000) Linking species diversity to the functioning of ecosystems: on the importance of environmental context. *Oikos* 91:175–183
- Cardinale BJ, Srivastava DS, Duffy JE, Wright JP, Downing AL, Sankaran M, Jouseau C (2006) Effects of biodiversity on the functioning of trophic groups and ecosystems. *Nature* 443:989–992
- Cardinale BJ, Bennett DM, Nelson CE, Gross K (2009) Does productivity drive diversity or vice versa? A test of the multivariate productivity–diversity hypothesis in streams. *Ecology* 90:1227–1241
- Chevan A, Sutherland M (1991) Hierarchical partitioning. *Am Stat* 45:90–96
- Diaz RJ, Rosenberg R (2008) Spreading dead zones and consequences for marine ecosystems. *Science* 321:926–929
- Draper NR, Smith H (1998) Applied regression analysis, 3rd edn. John Wiley & Sons, New York
- Duffy JE (2009) Why biodiversity is important to the functioning of real-world ecosystems. *Front Ecol Environ* 7:437–444
- Emmerson MC, Solan M, Emes C, Paterson DM, Raffaelli D (2001) Consistent patterns and the idiosyncratic effects of biodiversity in marine ecosystems. *Nature* 411:73–77
- Flint RW, Kalke RD (2005) Reinventing the wheel in ecology research? *Science* 307:1875–1876
- Fox J (2002) An R and S-Plus companion to applied regression. SAGE Publications, Thousand Oaks, CA
- Fridley JD (2002) Resource availability dominates and alters the relationship between species diversity and ecosystem productivity in experimental plant communities. *Oecologia* 132:271–277
- Fukami T, Wardle DA (2005) Long-term ecological dynamics: reciprocal insights from natural and anthropogenic gradients. *Proc R Soc B* 272:2105–2115
- Galbraith HS, Vaughn CC, Meier CK (2008) Environmental variables interact across spatial scales to structure trichopteran assemblages in Ouachita Mountain rivers. *Hydrobiologia* 596:401–411
- Gelman A, Hill J (2007) Data analysis using regression and multilevel/hierarchical models. Cambridge University Press, Cambridge
- Godbold JA (2008) Marine benthic biodiversity–ecosystem function relations in complex systems. PhD thesis, University of Aberdeen, Scotland
- Godbold JA, Solan M, Killham K (2009) Consumer species richness and identity effects on marine macroalgal decomposition. *Oikos* 118:77–86
- Grace JB (2006) Structural equation modelling and natural systems. Cambridge University Press, Cambridge
- Grace JB, Anderson TM, Smith MD, Seabloom E and others (2007) Does species diversity limit productivity in natural grassland communities? *Ecol Lett* 10:680–689
- Graham MH (2003) Confronting multicollinearity in ecological multiple regression. *Ecology* 84:2809–2815
- Healy C, Gotelli NJ, Potvin C (2008) Partitioning the effects of biodiversity and environmental heterogeneity for productivity and mortality in a tropical tree plantation. *J Ecol* 96:903–913

- Hector A, Schmid B, Beierkuhnlein C, Caldeira MC and others (1999) Plant diversity and productivity experiments in European grasslands. *Science* 286:1123–1127
- Hiscock K, Southward A, Tittley I, Hawkins S (2004) Effects of changing temperature on benthic marine life in Britain and Ireland. *Aquatic Conserv* 14:333–362
- Hooper DU, Chapin FS, Ewel JJ, Hector A and others (2005) Effects of biodiversity on ecosystem functioning: a consensus of current knowledge. *Ecol Monogr* 75:3–35
- Hughes AR, Byrnes JE, Kimbro DL, Stachowicz JJ (2007) Reciprocal relationships and potential feedbacks between biodiversity and disturbance. *Ecol Lett* 10:849–864
- Huston MA, McBride AC (2002) Evaluating the relative strengths of biotic versus abiotic controls on ecosystem process. In: Loreau M, Naeem S, Inchausti P (eds) *Biodiversity and ecosystem functioning: synthesis and perspectives*. Oxford University Press, Oxford
- Jolliffe IT (2002) *Principal component analysis*. Springer-Verlag, New York
- Jones MM, Tuomisto H, Borcard D, Legendre P, Clark DB, Olivas PC (2008) Explaining variation in tropical plant community composition: influence of environmental and spatial data quality. *Oecologia* 155:593–604
- Kristensen E (2000) Organic matter diagenesis at the oxic/anoxic interface in coastal marine sediments, with emphasis on the role of burrowing animals. *Hydrobiologia* 426: 1–24
- Kristensen ES, Ahmend SI, Devol AH (1995) Aerobic and anaerobic decomposition of organic matter in marine sediments: Which is fastest? *Limnol Oceanogr* 40:1430–1437
- Lecerf A, Risnoveanu G, Popescu C, Gessner MO, Chauvet E (2007) Decomposition of diverse litter mixtures in streams. *Ecology* 88:219–227
- Legendre P (1993) Spatial autocorrelation: Trouble or new paradigm? *Ecology* 74:1659–1673
- Legendre P, Legendre L (1998) *Numerical ecology*. Elsevier, Amsterdam
- Mac Nally R (2000) Regression and model-building in conservation biology, biogeography and ecology: the distinction between and reconciliation of 'predictive' and 'explanatory' models. *Biodivers Conserv* 9:655–671
- McNaughton SJ (1993) Biodiversity and function of grazing ecosystems. In: Schulze ED, Mooney HA (eds) *Biodiversity and ecosystem function*. Springer-Verlag, Berlin, p 361–384
- Mittelbach GG, Steiner CF, Scheiner SM, Gross KL and others (2001) What is the observed relationship between species richness and productivity? *Ecology* 82:2381–2396
- Murtaugh PA (2009) Performance of several variable-selection methods applied to real ecological data. *Ecol Lett* 12: 1061–1068
- Naeem S (2008) Advancing realism in biodiversity research. *Trends Ecol Evol* 23:414–416
- Pearson TH, Rosenberg R (1978) Macrobenthic succession in relation to organic enrichment and pollution of the marine environment. *Oceanogr Mar Biol Annu Rev* 16:229–311
- Pinheiro J, Bates D, DebRoy S, Sarkar D, R Core team (2009) nlme: linear and nonlinear mixed effects models. www.stats.bris.ac.uk/R/
- Quinn QP, Keough MJ (2002) *Experimental design and data analysis for biologists*. Cambridge University Press, Cambridge
- R Development Core Team (2007) *R: a language and environment for statistical computing*. R Foundation for Statistical Computing, Vienna, available at www.R-project.org
- Raffaelli D (2006) Biodiversity and ecosystem functioning: issues of scale and trophic complexity. *Mar Ecol Prog Ser* 311:285–294
- Rhoads DC, Germano JD (1986) Interpreting long-term changes in benthic community structure: a new protocol. *Hydrobiologia* 142:291–308
- Rhoads DC, McCall PL, Yingst JY (1978) Disturbance and production on the estuarine sea floor. *Am Sci* 66:577–586
- Romanuk TN, Vogt RJ, Kolasa J (2009) Ecological realism and mechanisms by which diversity begets stability. *Oikos* 118:819–828
- Ross DJ, Tate KR, Newton PCD, Wilde RH, Clark H (2000) Carbon and nitrogen pools and mineralization in a grassland clay soil under elevated carbon dioxide at a natural CO₂ spring. *Glob Change Biol* 6:779–790
- Solan M, Cardinale BJ, Downing AL, Engelhardt KAM, Ruesink JL, Srivastava DS (2004a) Extinction and ecosystem function in the marine benthos. *Science* 306: 1177–1180
- Solan M, Wigham BD, Hudson IR, Kennedy R and others (2004b) *In situ* quantification of bioturbation using time-lapse fluorescent sediment profile imaging (f-SPI), luminophore tracers and model simulation. *Mar Ecol Prog Ser* 271:1–12
- Solan M, Godbold JA, Symstad A, Flynn DFB, Bunker D (2009) Biodiversity–ecosystem function research and biodiversity futures: Early bird catches the worm or a day late and a dollar short? In Naeem S, Bunker DE, Hector A, Loreau M, Perrings C (eds) *Biodiversity and human impacts: ecological and societal implications*. Oxford University Press, Oxford
- Srivastava DS, Vellend M (2005) Biodiversity–ecosystem function research: Is it relevant to conservation? *Annu Rev Ecol Syst* 36:267–294
- Teal LR, Bulling MT, Parker ER, Solan M (2008) Global patterns of bioturbation intensity and mixed depth of marine sediments. *Aquat Ecol* 2:207–218
- Thompson K, Askew AP, Grime JP, Dunnett NP, Willis AJ (2005) Biodiversity, ecosystem function and plant traits in mature and immature plant communities. *Funct Ecol* 19: 355–358
- Tilman D, Naeem S, Knops J, Reich P and others (1997) Biodiversity and ecosystem properties. *Science* 278:1865–1869
- Troumbis AY, Memtsas D (2000) Observational evidence that diversity may increase productivity in Mediterranean shrublands. *Oecologia* 125:101–108
- Vitousek PM, Turner DR, Parton WJ, Sanford RL (1994) Litter decomposition on the Mauna Loa environmental matrix, Hawaii'i: patterns, mechanisms and models. *Ecology* 75: 418–429
- Walsh C, Mac Nally R (2008) hier.part: hierarchical partitioning. Available at www.stats.bris.ac.uk/R/
- Wardle DA, Zackrisson O, Hörnberg G, Gallet C (1997) The influence of island area on ecosystem properties. *Science* 277:1296–1299
- Worm B, Barbier EB, Beaumont N, Duffy JE and others (2006) Impacts of biodiversity loss on ocean ecosystem services. *Science* 314:787–790
- Zuur AF, Ieno EN, Walker N, Smith GM (2009) *Analysing ecological data using mixed modelling and extensions in R*. Springer, New York



Additive partitioning of estuarine benthic macroinvertebrate diversity across multiple spatial scales

Alf B. Josefson*

National Environmental Research Institute, Aarhus University, Frederiksborgvej 399, 4000 Roskilde, Denmark

ABSTRACT: Knowledge of how diversity changes across spatial scales is important for conservation of biodiversity. Alpha (α), beta (β) and gamma (γ) species richness and Shannon-Wiener diversity index (H') of benthic macroinvertebrates were analysed by additive partitioning across 3 different nested spatial scales (cm, m and km scales) in the estuarine Baltic Sea–North Sea transition area. The data set consisted of abundance of 324 species from a total of 638 samples taken at 64 sites distributed over 6 salinity-defined regions. Results were compared to a null model, randomly assigning individuals of species among samples. β -richness among regions was significantly high and the major contributor to γ -richness, while α - and β -richness were less than expected at finer scales, suggesting that salinity-defined regions largely determined γ -richness. Salinity effects on α -richness were positive and most evident at a regional scale, likely reflecting differential evolutionary adaptation to salinity among species. For H' , the greatest contribution to γ -diversity was from α and β at the finest scale, but significantly high contributions at larger scales likely indicated that different species dominated abundance in different sites and regions. Effects of rare species on partitioning of total richness was less different from random, compared to common species, for β among regions, suggesting that the occurrence of rare species was more affected by chance than for common species. Results suggest that additive partitioning is a simple and effective tool to unravel changes and sources in diversity over spatial scales in marine and/or estuarine benthic environments. This method may be used to assess effects of habitat homogenisation and as a basis for the design of conservation protocols.

KEY WORDS: Additive partitioning · α -diversity · β -diversity · γ -diversity · Species richness · Rare species · Macroinvertebrates · Salinity

Resale or republication not permitted without written consent of the publisher

INTRODUCTION

Biodiversity is generated by various factors operating at various scales (Wiens 1989, Willis & Whittaker 2002) and is therefore scale-dependent, and this is also true in marine sedimentary habitats (e.g. Hewitt et al. 1998, Ellingsen 2001). For instance, competition occurs among individuals and may therefore be more evident at fine spatial scales, while evolutionary history or dispersal may be more important at larger scales (e.g. Huston 1999). Therefore, in order to give a comprehensive description of diversity and its sources, it is desirable to study diversity components at multiple scales (Loreau 2000). Knowledge of how diversity

changes across spatial scales and of the processes behind these changes is important for conservation of biodiversity, because it will allow us to design optimal protocols to measure diversity loss which may have negative effects on ecosystem functioning (Loreau et al. 2001, Solan et al. 2004). For example, if bioturbating species are lost, benthic remineralisation rates may be altered (Lohrer et al. 2004), or if habitat-forming species are removed, species richness will decrease (Thrush et al. 2006).

A means of investigating changes in diversity across scales is additive partitioning of diversity (Lande 1996). Although diversity partitioning dates back to MacArthur et al. (1966) (Veech et al. 2002), the approach

*Email: aj@dmu.dk

where total diversity (γ) is broken up into additive parts of within-sample (α) and among-samples (β) diversity at lower spatial hierarchical levels was first used by Lande (1996). He showed that, mathematically, additive partitioning was feasible when concavity was present, i.e. when the sum of average diversities at smaller scales did not exceed diversity at the largest scale. Additive partitioning of diversity is particularly appropriate for studying how β changes over spatial scales and for identifying the scale that is most important in generating diversity such as species richness (Lande 1996, Gering et al. 2003). Crist et al. (2003) developed methods for statistical testing of additive partitioning of diversity and detecting sources of variability in diversity.

The approach has, in recent years, been applied to several terrestrial communities such as plants (Wagner et al. 2000, Fournier & Loreau 2001, Gabriel et al. 2006), insects (Fleishman et al. 2003, Gering et al. 2003, Summerville et al. 2003, Lindo & Winchester 2008) and birds (Fleishman et al. 2003, Veech & Crist 2007a) and some freshwater systems (e.g. Stendera & Johnson 2005). However, to date there are few applications of this method to marine and/or estuarine benthic invertebrate fauna.

Estuaries are transition zones between terrestrial and marine aquatic areas, which are important for instance due to their high productivity (Levin et al. 2001). They are, however, characterised by moderate levels of diversity and, given a strong relationship between diversity and function (e.g. Loreau et al. 2001, Solan et al. 2004), the redundancy in terms of function is likely to be less here, and the loss of species in these environments is thus likely to have serious consequences (Levin et al. 2001). Therefore, protection and maintenance of diversity in estuaries is important. In the present study, additive partitioning of diversity was applied to benthic invertebrate macrofauna in an estuarine area of NW Europe, the North Sea–Baltic Sea transition area, with the specific objective to investigate the importance of salinity on benthic diversity across different spatial scales. Although the general perception is that salinity is a major determinant of diversity in estuaries (Remane 1934, Bonsdorff & Pearson 1999, Attrill 2002, Attrill & Rundle 2002, Zettler et al. 2007), little is known about how its effects relate to spatial scales or how different diversity components, e.g. α - and β -richness or evenness, are affected.

A further issue addressed in the present study is how diversity changes across scales of species categories with different abundance and occupancy in the samples. Communities in soft sediments are often characterised by a great number of rare species, i.e. species that occur in few samples or in low numbers (e.g. Gray et al. 2005). The reason for rareness of a specific spe-

cies is seldom known and the importance of rare species in marine benthic systems has been a recent concern (Gray et al. 2005, Ellingsen et al. 2007, Fontana et al. 2008). Therefore, the additive partitioning approach was applied to the fauna with and without rare species in order to assess influence of rare species on partitions of the total community.

The following hypotheses were addressed:

(1) Null hypothesis: α - and β -diversity at 3 hierarchical levels—sample (cm scale), site (m scale) and region (km scale)—were obtained by random distribution of individuals among samples at the finest scale;

(2) Patterns of α - and β -diversity are related to differences in large-scale environmental characteristics, specifically salinity or sediment texture;

(3) Patterns of α - and β -diversity of rare and common species change in a similar way across scales; and

(4) Patterns of α - and β -diversity are similar among the 3 major taxonomic groups: Polychaeta, Mollusca and Crustacea.

MATERIALS AND METHODS

Study area and sampling design. The area of study (Fig. 1) comprised a major part of the Kattegat, the Sound and the southwestern Baltic Sea south of Sweden and Denmark, and extended over more than 250 km. The area is microtidal, with irregular changes in water levels due to high and low pressure forcing. Bottom water salinity over the study area varied from >30 psu in the northern area to around 10 psu in the Baltic Sea area (Table 1). The deeper areas (6 to 30 m) are separated from the Baltic Sea by the Drogden Sill in the Sound between Denmark and Sweden, and the water masses north of this sill are salinity-stratified during a large part of the year (Richardson & Christoffersen 1991, Rasmussen 1994). Water with lower salinity, mostly coming from the Baltic Sea, overlays the more saline water with a halocline at ca. 15 m water depth.

Fauna. Using the Danish environmental database DNAMAP, a database including environmental and faunal data collected by Danish local and regional authorities, invertebrate fauna data were selected from a total of 64 sites distributed as evenly as possible within each of 6 regions (Fig. 1, Table 1). From each site, usually visited once a year in April–June, 1 sample with 10 replicate core samples was taken. The samples were chosen from years as close together as possible. Of the 64 sites, 43 were visited in 1994 and most of the remaining sites in 1990. The replicate cores were taken with a Haps sampler (Kannevorff & Nicolaisen 1973) and each covered a bottom area of 0.0143 m² penetrated to ca. 15 cm in the sediment. The replicates were

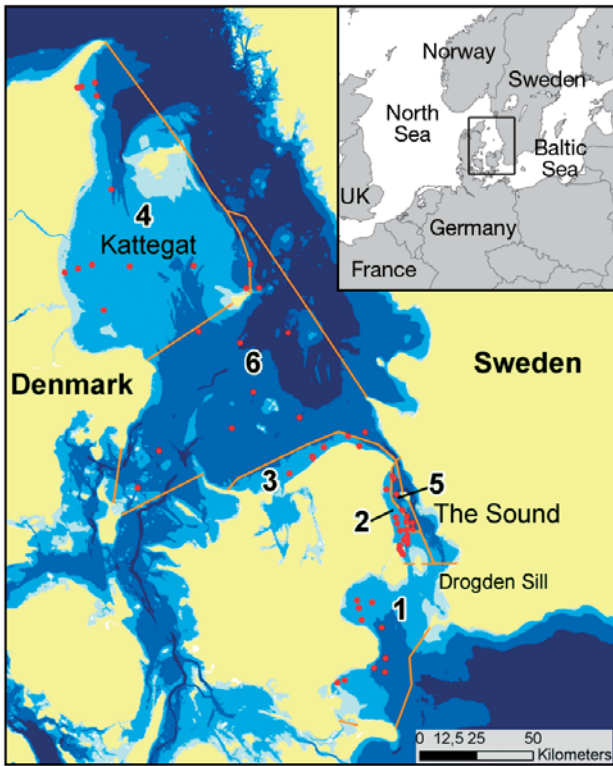

Fig. 1. Study area showing delineations of water mass-defined regions (orange borders) and positions of sites (red dots). Depth zones are indicated by blue shading, from light to dark in the following order: <5, 5 to 15, 15 to 30 and >30 m. The regions (ID numbers in black) were (1) Baltic Sea; (2) The Sound, 5 to 15 m; (3) S Kattegat, 5 to 15 m; (4) Jutland Shelf, 5 to 15 m; (5) The Sound, >15 m; and (6) Kattegat, >15 m

taken at random, mostly within an area of ca. 25 × 25 m at each site. The total area of the samples within each region varied between 1 and 2 m² (Table 1). The resulting hierarchical data set consisted of 638 samples nested within sites nested within regions. From each sample, data were selected on species abundances of the 3 major taxonomic macroinvertebrate groups: Polychaeta, Mollusca and Crustacea. These 3 groups

were each consistently determined to the lowest possible taxon, i.e. mostly to species level, and comprised a major part (often >90 % of species and individuals) of the fauna in the samples. The fauna material were extracted from the sediment using 1 mm sieves and otherwise treated following standard methods of preservation and determination of sediment macroinvertebrate fauna (Josefson & Hansen 2004).

Additive partitioning. According to the concept of additive partitioning (Lande 1996), the diversity in an area based on samples (γ) equals the sum of the average diversity within the sample (α) and the average diversity among the samples (β), so that $\gamma = \alpha + \beta$, and β consequently is given by $\gamma - \alpha$ (Crist et al. 2003). The additive view of β allows partitioning of total diversity into α - and β -diversity at several different nested scales. The application of additive partitioning into α - and β -diversity on the present material allows partitioning of total estuarine diversity into 3 hierarchical spatial levels: the sample unit, the site and the salinity-defined region (Fig. 2).

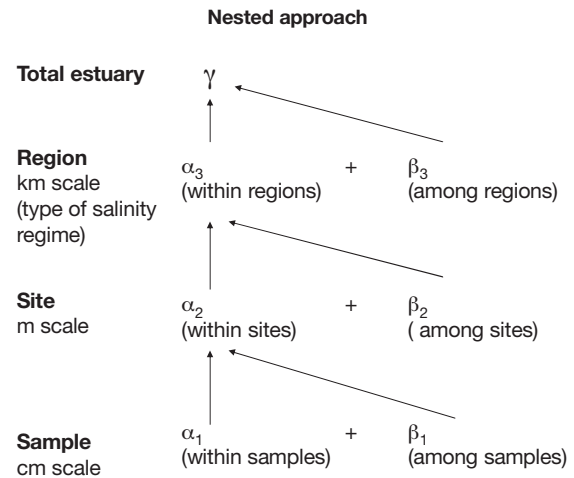

Fig. 2. Scheme of the additive partitioning sampling protocol. γ : gamma diversity; α : alpha; β : beta. By substitution, the overall diversity is described by: $\gamma = \alpha_{1\text{within-sample}} + \beta_{1\text{among samples}} + \beta_{2\text{among sites}} + \beta_{3\text{among regions}}$

Table 1. Summary data, including size, depth, salinity from bottom water and sediment texture for each of the 6 regions

Region (km scale)	Region size (km ²)	Water depth (m)	Bottom water salinity		No. of sites (m scale)	No. of samples (cm scale)	Sediment texture (no. of sites)		Sampled area (m ²)
			Mean	SD			Sand	Mud	
1. Baltic Sea	1700	5–30	12.04	1.19	10	99	4	6	1.42
2. The Sound	238	5–15	21.18	3.18	14	140	10	4	2
3. S Kattegat	389	5–15	22.4	1.17	7	70	7	0	1
4. Jutland Shelf	4680	5–15	26.86	1.36	13	130	8	5	1.86
5. The Sound	103	>15	28.67	1.8	8	80	1	7	1.14
6. Kattegat	4816	>15	32.07	0.9	12	119	7	5	1.7
Total					64	638			

Partitioning was performed on 2 different diversity measures, both fulfilling the criterion of concavity which requires that $\gamma \geq \alpha$ (Lande 1996): species richness (number of species) and the Shannon-Wiener diversity index (H'). It was expected that these 2 measures would generate different partitions as they measure different aspects of the community. Richness gives equal weight to all species, while H' gives equal weight to dominance or evenness and species richness, and consequently is much more influenced by diversity of the more abundant species.

Additive partitioning was performed on the total fauna (sum of the 3 major taxonomic groups) and on different selections of species, using the computer program PARTITION (Veech & Crist 2007b). The program was used for statistical testing of level-specific α and β estimates against a null model using a randomization procedure (Crist et al. 2003).

Since the focus here was on the presence of patterns of aggregation that could be related to salinity regimes, the complete unrestricted individual-based randomization approach was used. In brief, null distributions of the diversity measures at all hierarchical levels were created by randomly assigning the individuals among samples at the lowest level (finest scale) (Crist et al. 2003) and repeating this at least 999 times, at the same time preserving the original number of individuals per species and number of individuals per sample (sample size distribution). The observed diversity values were then compared to the null distributions; for example, if $<5\%$ of the distribution values were above the observed value, the value was considered significantly high at the 5% level. Similarly, if $>95\%$ of the null distribution values were above the observed value, it was considered significantly low at the 5% level.

Patterns of α - and β -diversity. Differences in large-scale environmental characteristics: Since the dependence of salinity effects on scale was part of the hypotheses, the grain of the largest scale was set to water mass-defined regions with more than 10 km extension. Contiguous bottom areas from 5 to 15 m depth and deeper than 15 m along the Kattegat–Sound–Baltic Sea transect formed 6 regions with different salinity regimes (Fig. 1, Table 1). The borders among these regions were more or less distinct because of the (often strong) vertical salinity stratification in the area (e.g. Richardson & Christoffersen 1991).

Sediment texture information at the sites was obtained from the Areal Information System (AIS) database (Danmarks digitale Havbundstypenkort 1:500 000, Geological Survey of Denmark and Greenland) where station positions were matched with sediment characterisation using GIS methods. The sites were classified as either mud (mud or sandy mud) or sand (sand or

coarser sediments) (Table 1). Region 3 was the most sandy since all sites were classified as sandy, and Region 5 was the most muddy with only 1 site classified as sandy. The remaining regions contained several sites from each sediment category.

Differences in sediment texture likely reflect differences in habitat, and therefore could affect β -diversity between regions if there were regional differences in texture. In order to evaluate the importance of sediment texture as a source of variability in diversity at the largest scale, the partitions were performed separately on the 4 regions with a more balanced composition of muddy and sandy sites, i.e. Regions 1, 2, 4 and 6 (Table 1), excluding the most sandy (3) and most muddy (5) regions.

In order to investigate how richness developed in relation to salinity across scales, α_1 , α_2 and α_3 (as defined in Fig. 2) were regressed against mean salinity within the regions.

Rare and common species: Since there is no consensus how to define rareness or commonness, both entities being relative, rare species were categorised in 2 different ways: (1) by total abundance and (2) by occupancy in the samples. Rare species defined by abundance were those that comprised $<0.05\%$ of the total number of individuals (<20 individuals), following the definition used by Gering et al. (2003) on arboreal Coleoptera, who used a similar-sized data set in terms of number of species and proportion of singletons (i.e. species occurring with only 1 individual). The remaining species thus were more common. Rare species defined by occupancy in the samples were those occurring in $<1\%$ of the 638 samples, i.e. in <7 samples. Partitions were conducted on species richness and H' on all species and with rare species excluded.

Taxonomic groups: The partitions were also made separately on each of the 3 taxonomic groups, Polychaeta, Mollusca and Crustacea, for 2 reasons. The first was to evaluate the possible influence of different life-history traits, mainly dispersal modes, on the partitions. Many species of the group Polychaeta have pelagic larval development (Thorson 1946) and are highly motile as adults. Mollusca contain a large fraction of species which disperse via pelagic larvae (Thorson 1946), but adults mostly have restricted motility. Most benthic macrofaunal crustacean species in the Kattegat and the North Sea belong to the order Peracarida, where major groups are Isopoda, Amphipoda and Cumacea, benthic recruiters (e.g. Myers 1997) with brooding and direct development without a pelagic stage (Ruppert & Barnes 1991). Dispersal by larvae in this group is therefore likely to be restricted; however, several crustacean species are motile as adults. Since pelagic larval dispersal is likely the most effective means of long-distance dispersal, Crustacea is

expected to be more aggregated at meso- and macro-scales than the other 2 groups. The second reason was to contribute to the debate about surrogates in diversity assessments; that is, do the diversity patterns of a single taxonomic group properly reflect the diversity pattern of the total community (e.g. Fleishman et al. 2003, Olsgard et al. 2003)?

RESULTS

Fauna

The total data set comprised 41 787 individuals and 324 species, of which 75 were singletons (Table 2). The number of species categorised as rare were of similar magnitude between the 2 methods of classification (i.e. by abundance and by occupancy). The most species-rich group was Polychaeta, followed by Crustacea and Mollusca. Most of the individuals belonged to Polychaeta and Mollusca, and Crustacea had the highest share of singletons (37 %).

Patterns of α - and β -diversity

Differences in large-scale environmental characteristics

The null hypothesis of random distribution among samples could be rejected for both species richness and H' at the 5 % level. For richness, the major contribution to γ -diversity was from β_3 (>65 %), which was much higher than expected from random. The contributions from α and β at finer scales were less than expected from the null model ($p < 0.05$), in particular β_1 (Fig. 3). For H' , the major contribution to γ -diversity was from α at the finest scale (ca. 50%) but, similar to richness, was less than expected from random (Fig. 4). The contributions from β_3 and β_2 were much higher than expected from random.

Table 2. Summary data on the fauna for the entire sampling area. Rare species were categorised in 2 ways, by abundance (<0.05 % of total abundance) and by occupancy (<1 % of samples). Singletons are species occurring with one individual. H' : Shannon-Wiener diversity index

Category	No. of individuals	No. of species	No. of singletons	H'
Total	41 787	324	75	3.38
Rare by abundance	1084	220		
Rare by occupancy	561	178		
Polychaeta	21 279	151	27	2.93
Mollusca	17 063	80	14	1.92
Crustacea	3445	93	34	2.25

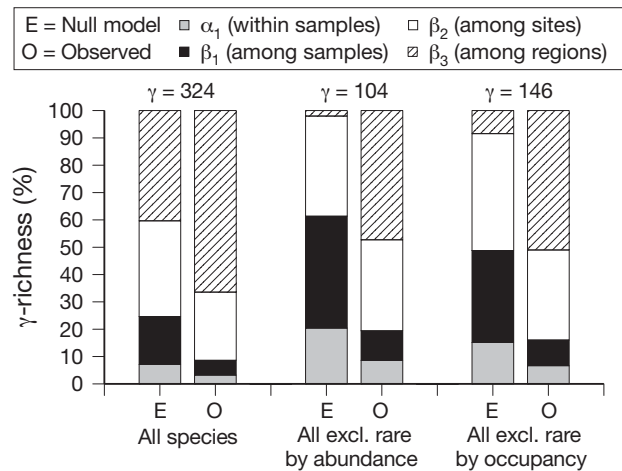

Fig. 3. Percentage of γ -richness explained by α and β components of diversity at 3 spatial scales: core samples, sites and water mass-defined regions. Observed data (O) are compared to expected (E) data from the null model. Results are shown for all species, and after excluding rare species by abundance or by occupancy. In all instances the observed partitions were significantly different ($p < 0.05$) from expectations of the null model

Results of the partitions run separately on regions with both sandy and muddy sediments showed similar results compared to predictions from the null model applied on all regions, with a contribution of β_3 to γ -diversity around 60 % for richness and ca. 9 % for H' (Table 3). Differences in sediment texture do not seem to generate much of the high β_3 observed when partitioning diversity from all regions. The remaining causal factor behind high β_3 is likely differences in water mass properties, most likely salinity. While additive partitioning allows identification of which scale is important for change in diversity, it does not give information on the direction of change versus the environmental factor. The development of α - and β -richness of the total fauna showed significant increases (Pearson product moment correlation, $p < 0.05$) versus bottom water salinity at all scales.

Rare and common species

Patterns of α - and β -diversity of rare and common species did not change in a similar way across scales when partitioning was performed on species richness, although statistical testing showed the same significant signs of deviation from the null model ($p < 0.05$) at each scale when rare species were excluded as for all species (Fig. 3). Clearly, inclusion of rare species, categorised either

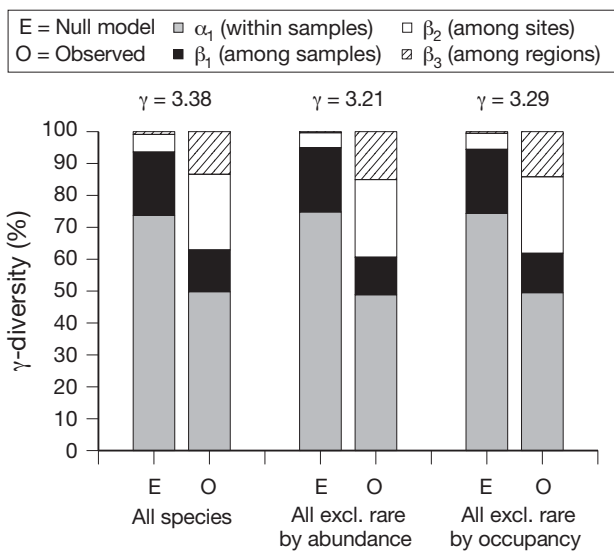

Fig. 4. Percentage of γ -diversity (Shannon-Wiener diversity index, H') explained by α and β components of diversity at 3 spatial scales: core samples, sites and water mass-defined regions. Observed data (O) are compared to expected (E) data from the null model. Results are shown for all species, and after excluding rare species by abundance or by occupancy. In all instances the observed partitions were significantly different ($p < 0.05$) from expectations of the null model

Table 3. Results of additive partitioning of γ -species richness (S) and Shannon-Wiener diversity index (H') for all species (total) and by taxonomic group (Polychaeta, Mollusca and Crustacea), sediment texture (Regions 1, 2, 4 and 6) and year (only 1994). Percent contribution of α and β to γ is given for the null model (Exp) and observed partitions (Obs). Significantly high contributions compared to random ($p < 0.05$) are in **bold**. The remaining observed values are, with one exception (ns: $p > 0.05$), significantly low at the 5% level

	α_1		β_1		β_2		β_3		γ
	Exp	Obs	Exp	Obs	Exp	Obs	Exp	Obs	
Total									
S	7.1	3.2	17.5	5.4	35	25	40.3	66.4	324
H'	73.8	49.8	19.8	13.1	5.5	23.7	0.9	13.4	3.38
Polychaeta									
S	8.1	3.9	19.3	6.3	35.8	26.4	36.8	63.4	151
H'	65.5	43.7	26	15.6	7.5	24	1	16.6	2.93
Mollusca									
S	7.8	3.9	16.4	6.4	37.8	27.6	38.1	62.1	80
H'	54.9	38	20.6	25.6 ^{ns}	23	33.3	1.4	3.1	1.92
Crustacea									
S	2.9	1.3	10.4	3.3	36.1	20.3	50.5	75.1	93
H'	25.8	14.3	31.8	22.2	38.2	27.7	4.2	35.8	2.25
Sediment texture									
S	7.8	3.6	18.6	5.9	40.4	30.5	33.1	60.1	295
H'	76.7	52.4	17.7	13.2	5.1	25.8	0.6	8.7	3.22
Year									
S	8.5	3.6	19.8	6.2	31.1	21.8	40.6	68.2	279
H'	76.2	50.5	18.4	12.3	4.45	18.9	1.1	18.4	3.37

by abundance or occupancy, decreased the deviation from the null model for partitions using all species, in particular at the largest scale, β_3 (Fig. 3). This implies that the more common species are more aggregated into regions than rare species, and that rare species occurrence is more affected by chance than richness of common species.

The partitions of H' were only slightly affected by exclusion of rare species (Fig. 4).

Taxonomic groups

Partitioning of total species richness for each taxonomic group (Table 3) generally showed a very high contribution, 62 to 75%, by β among regions, and this was significantly higher ($p < 0.05$) than expected from the random model (Table 3). At the same time, richness at the finer scales, in particular α_1 and β_1 , were significantly lower ($p < 0.05$) than expected from chance (Table 3). β -richness among sites (β_2), although significantly lower than expected from chance, showed the least difference from expected values for Polychaeta and Mollusca (Table 3). Partitioning and testing against the random model of total H' diversity (Table 3) showed a similar result as for richness, in that β_3 was much higher than expected and α_1 and β_1 were much lower than expected. β_2 values for Polychaeta and Mollusca, however, were significantly higher than expected ($p < 0.05$), which differed from the results for richness (Table 3). The contribution of α_1 to total diversity was, as expected, much higher for this diversity measure compared to richness.

The development of α -richness (α_1 , α_2 and α_3) versus bottom water salinity at all scales for Polychaeta and the 2 largest scales for Mollusca showed significant increases (Pearson product moment correlation, $p < 0.05$). The trends for Crustacea were not significant ($p > 0.05$), although Pearson r coefficients were positive at all scales (Fig. 5); the largest scale, region, is represented by total counts and, since sample numbers were different among regions, values obtained by rarefaction are shown for the same sample size (70 samples). The development of α -richness versus salinity was, in general, positive, but dependent on scale and taxonomic group, the latter in particular at the finest scales. Thus effects of salinity on richness were most apparent at the largest scale.

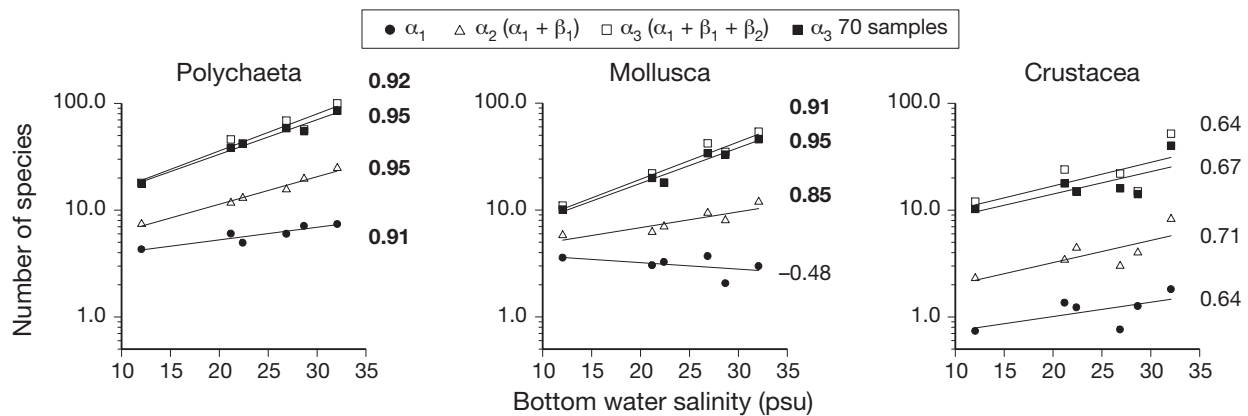

Fig. 5. Plots of average α_1 , α_2 and α_3 species richness of Polychaeta, Mollusca and Crustacea against mean bottom water salinity in the 6 regions. Since the number of samples differed among regions, α_3 ($\alpha_1 + \beta_1 + \beta_2$) is also given as the number of species in 70 samples from randomised accumulation curves. Pearson's r coefficients >0.80 (in **bold**) are significant at the 5% level

DISCUSSION

The present study was designed to assess the contribution of α and β , at 3 different spatial scales, to total diversity (γ), including the contribution of β among different water mass-defined bottom regions to γ . Additive partitioning allows γ -diversity to be partitioned on the basis of any categorical factor (such as habitat) and can therefore be used to analyse any postulated determinant of species diversity (Veech et al. 2002). Determination of diversity is highly dependent on sample grain and the extent of study, i.e. areal extent of the area sampled (Crist & Veech 2006). This is one reason for the statistical testing for significance of the partitions in the present study, since the extent of the regions differed by 1 order of magnitude (Table 1).

Results indicated that the overall null hypothesis must be rejected; diversity patterns in the area were not random. A significant finding was that the large-scale β component of richness was much greater than expected from random, which indicated that regional factors related to water mass-defined regions structure, in particular, species richness and composition in the area. At the same time, α and β at the finer scales were much less than expected from the null model. Thus species were, to a great extent, aggregated into regions. To test if this pattern was mainly influenced by spatial differences, partitions were run only on data from 1994, which resulted in more or less the same result as partitioning the total data set (Table 3). From the development of α_3 versus salinity, it was apparent that much of the high β_3 -richness was due to different levels of richness among regions, where high-saline regions contained more species than regions with lower salinity (Fig. 5).

While β_3 generated by far the greatest contribution to γ -richness, the α_1 component determined a large part of γ -diversity (H') although less than expected from random. However, the partitions of H' suggested a significantly high ($p < 0.05$) contribution to γ by both β_2 and β_3 . Since partitioning of richness showed a significantly low β_2 component, the significantly high β_2 component for H' is likely due to additions to the evenness component of H' , i.e. different species dominating at different sites. Partitioning of this evenness-influenced index thus tells us that the most common and/or dominant species contribute to total diversity over a range of scales.

Sediment structure is known to be important for the distribution of different species (e.g. Gray 2002) and to characterise different habitats. The question then was to what extent the different regions in the present study differed with respect to sediment structure and if this could explain some of the increase in β_3 . First, all samples were taken in sedimentary bottoms which allow penetration of the sampling gear to at least 15 cm depth. This ensured some similarity among sediments in different regions. In general, due to different exposure to waves, sediments at shallower depths are often sandier than sediments at greater depths. One shallow region was primarily sandy and one deep region was primarily muddy. The remaining regions contained both sandy and muddy sites. Since partitions using only the regions with both sediment types showed results similar to partitions using all 6 regions, sediment texture differences were likely of less importance than other factors behind the high β -diversity among regions. Remaining possibilities for increased β_3 , therefore, are differential adaptation of the benthic species to different regional salinity regimes, i.e. high

niche limitation (e.g. Gaston et al. 2007), or restrictions in dispersal between regions. Since there was no major difference in the partitions among the taxonomic groups with different dispersal modes (planktonic or benthic development) (Table 3), a high niche limitation is more likely the reason for the high β_3 . A likely mechanism is evolutionary adaptation to different salinity regimes.

The sea floor is often heterogeneous, or patchy, at different scales, from fine-scale biogenic patches (Hewitt et al. 2005) to benthic landscapes often geophysically formed (Zajac 2008a,b). In estuaries, the presence of water masses with different physicochemical properties, i.e. salinity, is one source of large-scale heterogeneity in species distributions on the bottom (e.g. Attrill & Rundle 2002). Theoretical work suggests that changed connectivity among patches will differentially affect the α , β and γ components of richness (Mouquet & Loreau 2003). Decreased dispersal among patches will increase β -diversity, and so will high niche specificity (Gaston et al. 2007). For instance, empirical studies in soft-sediment invertebrate communities showed that small-scale shell debris generated patchiness and maintained high β -diversity (Hewitt et al. 2005). The high contribution of β_3 to γ -richness in the present study suggests some barriers among regions (e.g. Lindo & Winchester 2008) which were defined by different water masses. Some previous studies in coastal areas have found high β -diversity between water masses, in agreement with the present study. Wagner (1999) reported high β -richness (species turnover) among different water masses in estuarine fish communities on the US east coast, and in the studied area Rosenberg & Möller (1979) demonstrated a major change in percent similarity based on presence/absence of species between invertebrate communities above and below the halocline at ca. 15 m depth along the Swedish west coast. There are, however, a few marine benthic studies that document change in β over several spatial scales, and most of them found the highest β at the finer scales (Hewitt et al. 2005 and references therein).

As in several terrestrial insect communities (e.g. Gerling et al. 2003), richness in marine communities is often dominated by rare species (Gray et al. 2005). Addition of rare species, such as singletons, is often the cause behind the continued increase of species-sample accumulation curves. The importance of rare species in marine invertebrate communities has been recently discussed in the literature (e.g. Gray et al. 2005, Ellingsen et al. 2007, Fontana et al. 2008). The occurrence of rare species has been attributed to sampling artefacts, due to extraction methods (Fontana et al. 2008) and/or undersampling of the populations. An additional possibility is that some rare species are 'vagrants'; that is, species accidentally dispersed

which do not have viable/reproductive populations in the environment of study. Gray et al. (2005) identified 2 different groups in the log-normal species abundance distributions which they named common and rare species, possibly indicating different functional groups, where the rare species were suggested to be recruited from outside the environment of study. In the present study, when species defined as rare were excluded, the partitions of the remaining species (the more common species) showed a different pattern of species richness compared to partitions of all species in relation to the random model.

β_3 -richness including rare species (all species) was significantly high and gave the highest contribution to γ -richness, but the increase in relation to the null model was modest. However, β_3 for the more common species was also significantly high, and several times higher than predicted. The contributions of α and β at the finer scales were significantly low for both all species and when excluding rare species. These results suggest that the more common species were more aggregated into regions than rare species, while rare species abundance deviated less from random. Since regions differed mainly with respect to salinity regimes, this may suggest that salinity affects richness of common species more than richness of rare species. These findings make sense, if common species represent species with viable populations adapted to the salinity regime in the region, and if some of the rare species represent vagrants that may occur in the region by chance. H' showed only minor differences between partitions (all species and excluding rare species); this is likely due to the fact that common species determine dominance, an important component of H' .

Contrary to expectation, there did not seem to be major differences in the partitions of richness among the 3 taxonomic groups, which suggests that dispersal or mobility were overridden by other factors. This may seem contradictory to Josefson & Hansen (2004), who found different relations among richness in these 3 groups and saltwater flux in Danish estuaries. However, data from the present study comes from an open area with comparatively high water flux rates, where water transport rates are not likely to be limiting for dispersal of pelagic or benthic larvae or even adults. However, there were differences among the 3 groups in the development of α_1 , α_2 and α_3 versus salinity. At the regional scale, there were strong positive relations between α_3 -richness and salinity for Polychaeta and Mollusca and an insignificant positive slope for Crustacea. Whether or not α -diversity at the smaller scales, sample (α_1) or site (α_2), were related to salinity was largely dependent on taxonomic group. Site richness (α_2) for Polychaeta and Mollusca was positively related to mean salinity, while this measure for Crustacea was

not significant. At the finest scale, α_1 , only richness of Polychaeta was related to salinity. These differences suggest that using species richness of either of the groups as a surrogate for each other is dependent on scale.

The weak response to changed salinity at the finest scale is in agreement with Hyland et al. (2004), who studied richness in eastern US estuaries.

The clear results of additive partitioning in the present study, which concur with the current knowledge about the estuarine environment, suggest that additive partitioning is an effective and simple way to assess sources of heterogeneity in diversity in marine and/or estuarine systems. It can give a sound basis for design of conservation actions; for instance, conservation of benthic invertebrate richness in the North Sea–Baltic Sea transition area demands a large-scale approach, with multiple sites within each region. This is because, to a great extent, different species occur in different salinity-defined regions. Additive partitioning could also be used to assess effects of homogenisation of habitats, which has occurred in several marine systems as a consequence of bottom trawling and eutrophication (e.g. Thrush & Dayton 2002, Thrush et al. 2006). For instance, homogenization by removing habitat-forming species may be predicted to decrease the β component at finer scales.

Acknowledgements. Thanks go to the local environmental authorities in Denmark for providing much of the data now stored in the DNAMAP database; to the Øresund Consortium for use of hydrographical and faunal data from the Sound; and to C. Göke for the GIS work. The comments from 4 anonymous referees greatly improved the paper. This is a contribution within the MARBEF Network of Excellence 'Marine Biodiversity and Ecosystem Functioning' EU 6th Framework Programme (contract no. GOCE-CT-2003-505446).

LITERATURE CITED

- Attrill MJ (2002) A testable linear model for diversity trends in estuaries. *J Anim Ecol* 71:262–269
- Attrill MJ, Rundle SD (2002) Ecotone or ecocline: ecological boundaries in estuaries. *Estuar Coast Shelf Sci* 55:929–993
- Bonsdorff E, Pearson TH (1999) Variation in the sublittoral macrozoobenthos of the Baltic Sea along environmental gradients: a functional-group approach. *Aust J Ecol* 24: 312–326
- Crist TO, Veech JA (2006) Additive partitioning of rarefaction curves and species–area relationships: unifying α -, β - and γ -diversity with sample size and habitat area. *Ecol Lett* 9:923–932
- Crist TO, Veech JA, Gering JC, Summerville KS (2003) Partitioning species diversity across landscapes and regions: a hierarchical analysis of α , β , and γ diversity. *Am Nat* 162: 734–743
- Ellingsen KE (2001) Biodiversity of a continental shelf soft-sediment macrobenthos community. *Mar Ecol Prog Ser* 218:1–15
- Ellingsen KE, Hewitt JE, Thrush SF (2007) Rare species, habitat diversity and functional redundancy in marine benthos. *J Sea Res* 58:291–301
- Fleishman E, Betrus CJ, Blair RB (2003) Effects of spatial scale and taxonomic group on partitioning of butterfly and bird diversity in the Great Basin, USA. *Landscape Ecol* 18: 675–685
- Fontana G, Ugland KI, Gray JS, Abbiati M (2008) Influence of rare species on beta diversity estimates in marine benthic assemblages. *J Exp Mar Biol Ecol* 366:104–108
- Fournier E, Loreau M (2001) Respective roles of recent hedges and forest patch remnants in the maintenance of ground-beetle (Coleoptera: Carabidae) diversity in an agricultural landscape. *Landscape Ecol* 16:17–32
- Gabriel D, Roschewitz I, Tscharnkte T, Thies C (2006) Beta diversity at different spatial scales: plant communities in organic and conventional agriculture. *Ecol Appl* 16: 2011–2021
- Gaston KJ, Evans KL, Lennon JJ (2007) The scaling of spatial turnover: pruning the ticket. In: Storch D, Marquet PA, Brown JH (eds) *Scaling biodiversity*. Cambridge University Press, Cambridge, p 181–222
- Gering JC, Crist TO, Veech JA (2003) Additive partitioning of species diversity across multiple scales: implications for regional conservation of biodiversity. *Conserv Biol* 17: 488–499
- Gray JS (2002) Species richness of marine soft sediments. *Mar Ecol Prog Ser* 244:285–297
- Gray JS, Bjørgesæter A, Ugland KI (2005) The impact of rare species on natural assemblages. *J Anim Ecol* 74: 1131–1139
- Hewitt JE, Thrush SF, Cummings VJ, Turner SJ (1998) The effect of changing sampling scales on our ability to detect effects of large-scale processes on communities. *J Exp Mar Biol Ecol* 227:251–264
- Hewitt JE, Thrush SF, Halliday J, Duffy C (2005) The importance of small-scale habitat structure for maintaining beta diversity. *Ecology* 86:1619–1626
- Huston MA (1999) Local processes and regional patterns: appropriate scales for understanding variation in the diversity of plants and animals. *Oikos* 86:393–401
- Hyland JL, Balthis WL, Posey M, Hackney CT, Alphin T (2004) The soft-bottom macrobenthos of North Carolina estuaries. *Estuaries* 27:501–514
- Josefson AB, Hansen JLS (2004) Species richness of benthic macrofauna in Danish estuaries and coastal areas. *Glob Ecol Biogeogr* 13:273–288
- Kannerworf E, Nicolaisen W (1973) The Haps, a frame-supported bottom corer. *Ophelia* 10:119–129
- Lande R (1996) Statistics and partitioning of species diversity, and similarity among multiple communities. *Oikos* 76: 5–13
- Levin LA, Boesch DF, Covich A, Dahm C and others (2001) The function of marine critical transition zones and the importance of sediment biodiversity. *Ecosystems* 4: 430–451
- Lindo Z, Winchester NN (2008) Scale dependent diversity patterns in arboreal and terrestrial oribatid mite (Acari: Oribatida) communities. *Ecography* 31:53–60
- Lohrer AM, Thrush SF, Gibbs MM (2004) Bioturbators enhance ecosystem function through complex biogeochemical interactions. *Nature* 431:1092–1095
- Loreau M (2000) Are communities saturated? On the relationship among α , β and γ diversity. *Ecol Lett* 3:73–76
- Loreau M, Naeem S, Inchausti P, Bengtsson J and others (2001) Biodiversity and ecosystem functioning: current knowledge and future challenges. *Science* 294:804–808

- MacArthur R, Recher H, Cody M (1966) On the relation among habitat selection and species diversity. *Am Nat* 100:319–332
- Mouquet N, Loreau M (2003) Community patterns in source-sink metacommunities. *Am Nat* 162:544–557
- Myers AA (1997) Biogeographic barriers and the development of marine biodiversity. *Estuar Coast Shelf Sci* 44:241–248
- Olsgaard F, Brattegard T, Holthe T (2003) Polychaetes as surrogates for marine biodiversity: lower taxonomic resolution and indicator groups. *Biodivers Conserv* 12:1033–1049
- Rasmussen B (1994) Blandningsmekanismer i kystnære farvande. Havforskning fra Miljøstyrelsen, No. 32. Miljøstyrelsen, Copenhagen
- Remane A (1934) Die Brackwasserfauna (Mit besonderer Berücksichtigung der Ostsee). *Zool Anz* 7(Suppl):34–74
- Richardson K, Christoffersen A (1991) Seasonal distribution and production of phytoplankton in the southern Kattegat. *Mar Ecol Prog Ser* 78:217–227
- Rosenberg R, Möller P (1979) Salinity stratified benthic macrofaunal communities and long-term monitoring along the west coast of Sweden. *J Exp Mar Biol Ecol* 37:175–203
- Ruppert EE, Barnes RD (1991) *Invertebrate zoology*, 6th edn. Saunders College Publications, New York
- Solan M, Cardinale BJ, Downing AL, Engelhardt KAM, Ruesink JL, Srivastava DS (2004) Extinction and ecosystem function in the marine benthos. *Science* 306:1177–1180
- Stendera SES, Johnson RK (2005) Additive partitioning of aquatic invertebrate species diversity across multiple scales. *Freshw Biol* 50:1360–1375
- Summerville KS, Boulware MJ, Veech JA, Crist TO (2003) Spatial variation in species diversity and composition of forest Lepidoptera in eastern deciduous forests of North America. *Conserv Biol* 17:1045–1057
- Thorson G (1946) *Reproduction and larval development of Danish marine bottom invertebrates*. C. A. Reitzels Forlag, Copenhagen
- Thrush SF, Dayton PK (2002) Disturbance to marine benthic habitats by trawling and dredging: implications for marine biodiversity. *Annu Rev Ecol Syst* 33:449–473
- Thrush SF, Gray JS, Hewitt JE, Ugland KI (2006) Predicting the effects of habitat homogenization on marine biodiversity. *Ecol Appl* 16:1636–1642
- Veech JA, Crist TO (2007a) Habitat and climate heterogeneity maintain beta-diversity of birds among landscapes within ecoregions. *Glob Ecol Biogeogr* 16:650–656
- Veech JA, Crist TO (2007b) PARTITION: software for the hierarchical additive partitioning of species diversity, version 2. Available at: www.users.muohio.edu/cristto/partition.htm
- Veech JA, Summerville KS, Crist TO, Gering JC (2002) The additive partitioning of species diversity: recent revival of an old idea. *Oikos* 99:3–9
- Wagner CM (1999) Expression of the estuarine species minimum in littoral fish assemblages of the lower Chesapeake Bay tributaries. *Estuaries* 22:304–312
- Wagner HH, Wildi O, Ewal KC (2000) Additive partitioning of plant species diversity in an agricultural mosaic landscape. *Landscape Ecol* 15:219–227
- Wiens JA (1989) Spatial scaling in ecology. *Funct Ecol* 3:385–397
- Willis KJ, Whittaker RJ (2002) Species diversity: scale matters. *Science* 295:1245–1248
- Zajac RN (2008a) Macrobenthic diversity and sea floor landscape structure. *J Exp Mar Biol Ecol* 366:198–203
- Zajac RN (2008b) Challenges in marine, soft-sediment benthoscape ecology. *Landscape Ecol* 23:7–18
- Zettler ML, Schiedek D, Bobertz B (2007) Benthic biodiversity indices versus salinity gradient in the Southern Baltic Sea. *Mar Pollut Bull* 55:258–270

Submitted: May 2, 2009; Accepted: October 19, 2009

Proofs received from author(s): November 26, 2009



Life history mediates large-scale population ecology in marine benthic taxa

Thomas J. Webb^{1,*}, Elizabeth H. M. Tyler¹, Paul J. Somerfield²

¹Department of Animal & Plant Sciences, University of Sheffield, Sheffield S10 2TN, UK

²Plymouth Marine Laboratory, Prospect Place, The Hoe, Plymouth PL1 3DH, UK

ABSTRACT: Progress in marine biodiversity research requires a suite of approaches to understand processes occurring across a broad range of spatial scales. Macroecology provides a useful framework for understanding how local- and regional-scale processes interact, and comparative analyses of residual variation around macroecological relationships offer a promising route to better understand how the biological and ecological traits of individual species influence large-scale patterns in diversity. We combined data on the distribution and abundance of 575 North Sea macrobenthic species with a new species-level biological traits database to determine the effects of life history on the relationship between local population density and regional occupancy. We found the strongest effects were for body size: for a given local population density, larger-bodied species tended to be more widely distributed than smaller-bodied species (controlling for taxonomic affinities between species). This indicates a broad trend for large-bodied species to have relatively less aggregated distributions than smaller-bodied species, and is the first demonstration in marine systems that abundance–occupancy relationships are mediated by body size. We suggest that this effect is most likely due to the interrelationships between body size and other life-history traits that influence the large-scale dispersal of individuals, in particular, mode of larval development and adult migratory habit. The ability of a single life-history trait to capture this variation in spatial structure suggests that our approach could relatively easily be applied to more extensive marine data sets in the future.

KEY WORDS: Macroecology · Body size · Abundance–occupancy relationships · Comparative methods · Biological traits

Resale or republication not permitted without written consent of the publisher

INTRODUCTION

By most measures, research into marine biodiversity lags behind biodiversity research in other realms (Raffaelli et al. 2005, Hendriks et al. 2006, Clarke et al. 2007, Richardson & Poloczanska 2008). Yet it is vital that we understand fundamental patterns in the distribution and abundance of marine taxa so that we can predict both the responses of these taxa to widespread human activity in the oceans (Halpern et al. 2008) and the likely consequences of these responses on the ecosystem services provided by the marine environment (Worm et al. 2006). This will require progress in fundamental descriptions of marine diversity, in understanding the functional roles of different taxa and

ecosystems, and in developing innovative strategies for marine conservation (Webb 2009). Such a daunting task will require a suite of complementary approaches. One of these, macroecology, provides a useful conceptual and methodological framework for understanding how local- and regional-scale processes interact to produce large-scale patterns in diversity (Freckleton et al. 2005, Webb et al. 2007, 2009), and how these patterns are likely to change under various scenarios of global change (Kerr et al. 2007), thus providing a link between the themes of future marine biodiversity research.

One promising avenue for macroecological research is to explore how variation in macroecological patterns and relationships is related to the biological and eco-

*Email: t.j.webb@sheffield.ac.uk

Table 1. Summary of previous studies linking the relationship between population density and site occupancy with life-history traits. For comparison with the present study, we interpret the results of each study in terms of spatial aggregation. Thus, a trait which is associated with a lower occupancy for a given density has a higher aggregation effect than alternative traits. See 'Materials and methods' for details on inferring patterns of aggregation from abundance–occupancy relationships

	Spatial scale	No. species	Life-history trait	Aggregation effect	Source
Butterflies	Britain	49	Mobility	Low mobility > high mobility	Cowley et al. (2001)
Estuarine macroinvertebrates	Britain	95	Development mode	No effect	Foggo et al. (2003)
Birds	Britain	67	Dispersal ability	No effect	Gaston & Blackburn (2003)
Birds	Britain	111	Trophic group	No effect	Holt & Gaston (2003)
Mammals	Britain	36	Trophic group	No effect	Holt & Gaston (2003)
Stream insects	Koutajoki drainage system, Finland	74	Trophic group	No effect	Heino (2005)
Frogs	Australia	97	Reproductive effort	Few large eggs > many small eggs	Murray & Hose (2005)
Frogs	Australia	97	Body size	No effect	Murray & Hose (2005)
Subtidal macroinvertebrates	Britain	362	Development mode	Non-planktonic > planktonic	Foggo et al. (2007)
Lichens on gravestones	Southern Britain	103	Colonisation	Poor colonisers > good colonisers	Leger & Forister (2009)

logical traits of the component species. A useful way to link macroecological relationships with the biological traits of component species is by considering the likely effects of these traits on the spatial clustering of individuals within species. Spatial clustering—or aggregation more generally—is key in moving from simple counts of individuals or frequency of occurrence patterns to more nuanced macroecological relationships such as species–area relationships, local species abundance distributions, and abundance–occupancy relationships (Holt et al. 2002, Harte et al. 2005, Tjørve et al. 2008). The overwhelming tendency is for species to display spatial distributions that are more aggregated than predicted by random placement of individuals (Clarke et al. 2006, Green & Plotkin 2007). Importantly, there are also predicted links between patterns of aggregation and life-history traits (e.g. Clarke et al. 2006), particularly those, such as mode of reproduction, which are likely to influence the movement of individuals between patches. Population modelling studies have also suggested that factors such as dispersal and colonization potential, as well as patterns in habitat utilisation, can radically modify the statistical relationship between local and regional population size (Freckleton et al. 2005, 2006), in part through their effects on spatial aggregation.

Comparative studies, however, have often failed to find robust life-history and ecological correlates of the relationship between local and regional abundance (Table 1). One reason for this may be the comparative lack of variation in life history within the (mostly terrestrial) systems previously studied (Webb et al. 2009), which have often been restricted to sampling only a taxonomic subset of vertebrates present at each site. In contrast, sampling in the marine environment tends to target the entire biological community within a particular habitat. Given that marine systems have considerably more diversity at higher taxonomic levels than terrestrial systems (May 1994), this means that marine data sets typically encompass significant variation in key functional traits. Thus, comparisons of macroecological patterns can be made between taxa differing in fundamental traits such as means of larval dispersal. For example, Jablonski (1986) found that fossil mollusc species with a planktonic phase were regionally more widely distributed than species with direct larval development. More recently, Foggo et al. (2007) found that for subtidal macroinvertebrates around the coast of Britain, those with planktotrophic larvae tended to have a high regional distribution for a given mean local abundance compared to species with lecithotrophic larvae or brooding species, indicating that restricted larval dispersal may lead to greater local retention of larvae, and thus higher local abundance at lower geographic range sizes.

The increasing availability of large databases documenting the abundance and distribution of large numbers of marine species across entire regions (e.g. Vanden Berghe et al. 2009), together with rising interest in documenting the biological traits of marine species (e.g. Bremner et al. 2003, 2006), means that there is potential for extending the scope of such important comparative analyses. In the present study we explore the relationship between local and regional population ecology and life history for 575 macrobenthic infaunal species from the North Sea, by adapting phylogenetic comparative methods for use with information on taxonomic relatedness. We first show how local population density is related to regional occupancy, and how this abundance–occupancy relationship can be interpreted in terms of interspecific differences in the degree of spatial clustering of individuals between sites. We use a new database of key life-history traits to provide the first estimates of the degree of taxonomic conservatism in macroecological and biological traits for these taxa, and explore the potential of interspecific variation in life history to explain variation in spatial clustering. Our results highlight how life history can play a key role in shaping the interactions between local and regional population processes within species, and so provide a more thorough understanding of large-scale patterns of marine biodiversity.

MATERIALS AND METHODS

Distribution and abundance data. We used data on the macrobenthic infauna of the North Sea taken from the North Sea Benthos Survey (NSBS; Craeymeersch et al. 1997). Full details of the sampling methodology are given elsewhere (ICES 1986). Briefly, the purpose of this survey, conducted between 1980 and 1986, was to provide a qualitative and quantitative description of the benthic communities of the North Sea. Benthic samples were taken in a standardised way, using grab and box-cores for macrobenthic infauna, on a regular grid covering the whole of the North Sea. These data have formed the basis for complete descriptions of the North Sea macrobenthos (e.g. Heip et al. 1992). The data used here include 575 macrobenthic species occurring across 231 sampling stations between 51.25 and 60.75°N and 3°W and 9°E. Taxonomy follows the European Register of Marine Species (www.marbef.org/data/erms.php). More details on taxonomic and additional quality control can be found in the description of the recently completed MacroBen database (Vanden Berghe et al. 2009), of which the NSBS forms a part.

Macroecological variables. The primary macroecological variables used in the present study are site occupancy and maximum local density. Occupancy is

simply the number of sampling stations at which a species was recorded in at least 1 replicate sample, and ranges across the 575 species between 1 and 180 stations. All abundance data in the NSBS are given as individuals m^{-2} . Typically, macroecological studies linking local population density with regional occupancy take mean local population density as the average density attained by a species across those sampling stations at which it occurred (e.g. Freckleton et al. 2005, Webb et al. 2007, 2009). In the present study we also consider maximum density for the following reasons. First, previous studies have shown that occupancy varies between species primarily due to changes in maximum, rather than mean or minimum, density (Gaston et al. 2000). Second, maximum density is likely to be more accurately estimated from sample data than is mean density. For example, the amphipod *Bathyporeia pilosa* was recorded at only a single sampling station, but at a high density (141.3 ind. m^{-2} , the highest mean density in our data set). This seems much more likely to represent a high density for this particular species than a typical density. We used these estimates to calculate the relationship between local density and regional occupancy across taxa. Such abundance–occupancy relationships are generally significantly positive across a wide range of taxa (e.g. Blackburn et al. 2006), and provide an important link between local and regional populations (Freckleton et al. 2005). Abundance–occupancy relationships are also strongly related to the spatial structure of populations within species (e.g. Holt et al. 2002, Freckleton et al. 2006). A range of measures have been proposed to measure the spatial structure of populations based on counts of individuals occurring across different sampling units, including the clumping parameter from fitted negative binomial distributions (Freckleton et al. 2006) and species-specific indices of dispersion (Clarke et al. 2006). Both of these measures, as well as most other measures of spatial aggregation (e.g. Patil & Stiteler 1973), rely on the availability of counts of individuals, which are not available for the NSBS. Instead, we used estimates of variance in density (across occupied samples only) for the 428 species which occurred in >1 sample. By dividing species into \log_2 occupancy classes (with the first class representing all occupancies of 2 to 3, the second 4 to 7, the third 8 to 15, and so on), we then estimated the relationship between density and variance in density for species with differing occupancies, by fitting a model of $\log(\text{variance in density} + 1) = \text{occupancy class} \times \log(\text{density})$. This enabled us to interpret variation in the relationship between density and occupancy in terms of the spatial distribution of individuals.

Life-history data. In order to compare spatial patterns of distribution across species with contrasting life histories, we collected data on the biological traits of all

species in our data set. Data on a range of traits were obtained from the Biological Traits Information Catalogue (www.marlin.ac.uk/biotic/) and from J. Bremner and H. Tillin unpubl. data. These were supplemented with data on specific traits from published and unpublished sources, most notably body size from Hayward & Ryland (1991a,b). We considered 7 biological traits selected to represent key facets of life history, in particular those likely to influence dispersal of individuals at various life stages between patches (and for which sufficient data were available for meaningful analyses). To make best use of available data, information for all traits was collected on a categorical scale; details of these categories for each trait, together with the number of species for which data were available, are given in Table 2.

Body size is often considered to be the defining life-history trait (e.g. Peters 1983, Hildrew et al. 2007), in part because of its importance (particularly in aquatic environments) in structuring trophic interactions (e.g. Jennings et al. 2008), but also because it frequently correlates with a suite of other life-history traits (e.g. Peters 1983, Atkinson & Hirst 2007). A further important consideration is that basic body size data are often

available for more species than other life-history traits. To complement the major sources of data used to construct our database, which have classified body size on a categorical scale, all additional body size data that we have collected has also been aggregated into the 5-point categorical scale defined in Table 2. We were also limited by available data to considering only a single axis of body size (maximum linear dimension), which will clearly fail to capture the full extent of differences between taxa with very different body forms; but it is sufficient, particularly when measured at the relatively coarse scale used here, to distinguish large differences in size between taxa.

Of the other traits, larval developmental mechanism has been hypothesised to influence spatial distribution through its effect on spatial clustering (Clarke et al. 2006), and indeed does appear to be important in determining macroecological patterns (Jablonski 1986, Foggo et al. 2007). Clearly, it plays a large role in determining the large-scale dispersal potential of species. Other traits which will influence the dispersal potential of an organism over its lifespan include the duration of its life, and the mobility of adults both habitually and during less regular migration events.

Table 2. Descriptions of the 7 life-history traits used in the present study, and the number of species (N) for which data were available

Trait	N	Definition	Categories and definitions
Body size	324	Maximum recorded body size, defined as maximum linear dimension	1: <1 cm; 2: 1–2 cm; 3: 3–10 cm; 4: 11–20 cm; 5: ≥21 cm
Development mode	124	Mode of larval development	Planktonic (including both planktotrophic and lecithotrophic development); non-planktonic
Feeding method	125	The method by which a species feeds, encapsulating resource type rather than specific dietary components	Predators and scavengers; active and passive suspension feeders (filter feeders); suspension and deposit feeders; deposit feeders (feeding on organic matter interstitially or on the surface of the substrate, therefore combining surface and sub-surface deposit feeders)
Lifespan	97	Longest recorded lifespan	≤1 yr; >1 yr
Adult mobility	129	The method of movement in the adult stage	Crawling; burrowing (actively burrows through the substrate); swimming and drifting; attached (permanently or temporarily attached to the substrate or living statically in a burrow, functionally sessile)
Migration	105	Significant post-first settlement horizontal movement; includes seasonal migration and migration for reproduction (even if these only occur once in the lifespan) but not normal daily movements, larval dispersal, or vertical migration	Yes (migration occurs); no (no evidence for migration)
Sociability	110	The extent to which a species usually aggregates	Solitary (predominantly living on their own); gregarious (predominantly living in groups or clusters, or colonially living in tissue in contact with each other)

Feeding method may also be important in reflecting how species distribution patterns follow the distribution of resources; and finally we consider sociability as a direct measure of aggregation at the local level.

Clearly, there is likely to be intraspecific (even intra-individual) variation in some, if not all, of these traits. We therefore sought to assign species to categories based on the predominant behaviour recorded in the literature. For some traits (for instance, adult mobility) in some species, 2 movement methods were equally used. In this case, we assigned the species to the category thought to reflect highest mobility. For migratory habit, species were only considered to be migratory if there was good evidence for the existence of migration.

Statistical analyses. As outlined above, relationships between life-history variables and spatial aggregation can be assessed by means of the relationship between occupancy and maximum density. Specifically, we considered linear models with occupancy as the response, and density as one predictor together with one or more life-history covariates. Several issues need to be addressed in this kind of comparative analysis. First, because occupancy is bounded at both ends (for our data, all occupancies must be >0 and <231), there is an argument for fitting a binomial model, considering occupancy as a proportion (e.g. Faraway 2005). However, because no species in our data set approached full occupancy, we prefer to use simple linear models for ease of interpretation of coefficients, and because implementation of the phylogenetic correction (see below) is straightforward in this case. We transformed occupancy using the logit transformation recommended by Williamson & Gaston (1999), where $\text{logit}(\text{occupancy}) = \log(\text{proportion of occupied samples}) - \log(\text{proportion of unoccupied samples})$. We note, however, that similar patterns to those reported here are observed if binomial generalized linear models (GLMs) are employed.

The analysis of comparative data across species raises other statistical issues. For instance, species are not independent data points, being related to a greater or lesser degree due to shared evolutionary history (Harvey & Pagel 1991). A variety of methods have been developed to address phylogenetic non-independence in comparative data. We employed the method described in Freckleton et al. (2002) to fit phylogenetically weighted generalized least squares models (PGLMs). This method is simple to implement in R (R Development Core Team 2008) using the CAIC package (Orme et al. 2008), and is readily interpreted in terms of linear models. Ideally it requires a fully resolved phylogeny including all species in the data set; however, in the absence of such a scheme (as for our data), it is possible to use a simple similarity matrix

using taxonomic information. We therefore assumed that, across the species in our data set, taxonomy to a first approximation reflects evolutionary history, and so is useful in representing at a crude scale the relationships between species. This is preferable to ignoring evolutionary history entirely in a comparative analysis (R. P. Freckleton pers. comm.), and it seems reasonable to propose that species within the same genus are more closely related to each other than to species in different genera within the same family; species within the same family are more closely related to each other than to species in different families within the same order; and so on. We constructed a matrix quantifying the similarity between all pairs of species as follows. First, species within the same phylum score 1, species in different phyla zero. Next, species in the same class score an additional $1/2$, species in the same order $1/4$, species in the same family $1/8$, and species in the same genus $1/16$. Finally, $1/32$ was added to the diagonal of this similarity matrix to ensure that the highest degree of similarity ($63/32$) occurs for each species with itself. This weighting scheme for similarities was chosen to reflect the fact that the lowest similarities (i.e. greatest evolutionary distances) occur between distinct phyla, whereas species within the same genus are generally separated by relatively little independent evolutionary history. By down-weighting relationships within each taxonomic group compared to the higher taxon in which it is contained, this scheme also addresses to a certain extent the issue highlighted by Purvis & Hector (2000): that taxonomic boundaries do not represent equivalent amounts of evolutionary history across major taxonomic groups.

We used this similarity matrix (standardised so that similarity ranged from 0 to 1) to provide the first estimates of taxonomic signal in macroecological and life-history variables for the North Sea macrobenthos, by estimating for each trait the maximum likelihood (ML) value of λ , which varies between zero (when evolution of a trait is entirely unrelated to phylogeny) and 1 (which indicates that evolution of the trait is entirely consistent with a Brownian evolutionary model). We used the likelihood test presented in Freckleton et al. (2002) to test whether the ML value of λ differed significantly from these 2 extremes. We then used PGLMs to incorporate the taxonomic similarity matrix into our models relating occupancy to density and covariates, and so all of the coefficients reported here are corrected for the taxonomic similarity between species.

Two further statistical issues concern collinearity between explanatory variables, and missing data. We expected some relationship between most of the life-history variables outlined in Table 2, although it was not clear *a priori* exactly what form these relationships might take. Correlation between explanatory variables

within a model can bias parameter estimates (e.g. Quinn & Keough 2002). Various strategies are available to deal with this issue, but these are confounded by the fact that our data set contains a substantial proportion of missing data, and different species are missing data for different traits. Our knowledge of biological traits for these species is not sufficiently complete to justify methods for imputing missing values (e.g. Nakagawa & Freckleton 2008), and it also makes estimating correlations between explanatory variables problematic. Moreover, model selection and averaging methods to assess the relative importance of predictor variables (e.g. Johnson & Omland 2004) require that the same records are included in all models; with our data this would greatly reduce the number of species available for analysis for some individual traits. We therefore adopted the following approach. First, we assessed each of the life-history variables in turn, using a separate PGLM for each variable. For each covariate x we fit a model of the form $\text{logit}(\text{occupancy}) = \log(\text{maximum density}) \times x$; in the case of the interaction between density and x not being significant, we fitted a model including main effects only. These models therefore use the maximum number of species with data available for each trait.

To assess the relative importance of the various life-history covariates, we restricted the database to those species with data available for 6 of the life-history variables described in Table 2 (we excluded lifespan from this analysis because there was no variation in this trait across those species with data available for all the other traits). For these 85 species, we first fitted a model of $\text{logit}(\text{occupancy})$ on $\log(\text{maximum density})$, all 6 covariates, and the six 2-way interactions between density and each covariate. However, given that no interaction was significant, we considered a model containing only the main effects of each predictor as our full model against which to assess the importance of each predictor. We employed an Information Theoretic approach to determining the importance of each covariate, using the unbiased estimator Akaike's Information Criterion (AIC_c) corrected for small sample size (Johnson & Omland 2004) to compare all possible combinations of predictors (i.e. 2^7 models for the 7 predictors). Our approach follows that described in Webb et al. (2005), using Akaike weights w_i both to define a 95% confidence set of models and to determine for each predictor the probability that it appears in the best approximating model (Burnham & Anderson 2002, Johnson & Omland 2004). These probabilities calculated for each variable were compared to the 95% range of probabilities of including a randomly generated, uncorrelated predictor based on 100 randomisations (see Webb et al. 2005 for more details) to give an additional indication of the importance of each variable. For reasons of computational efficiency, we did not con-

sider taxonomic relatedness during this model selection procedure; however, we did rerun the preferred model as a PGLM including the similarity matrix described above. All data manipulation and analysis used R 2.8.1 (R Development Core Team 2008).

RESULTS

Taxonomic signal in individual traits

Values of λ for the macroecological and life-history variables are shown in Table 3. All estimates were significantly >0 , indicating substantial taxonomic signal across these diverse traits, although for all traits apart from migration λ was also significantly <1 , suggesting that significant variation remains unexplained by taxonomic affiliation. Based on the limited number of traits assessed here, values of λ for macroecological variables appear to be smaller than those for life-history variables (mean \pm SE = 0.74 ± 0.034 and 0.39 ± 0.029 for life-history and macroecological variables, respectively); indeed, this difference was significant ($t = 3.23$, $df = 9$, $p = 0.0103$), with the caveat that not all variables are strictly independent of each other.

Relationship between occupancy, density and aggregation

Regional occupancy was significantly positively related to mean local density (Fig. 1a), with the slope (\pm SE) of a PGLM of $\text{logit}(\text{occupancy})$ on $\log(\text{mean density})$ of 0.64 ± 0.080 ($p < 0.0001$); the model R^2 was

Table 3. Maximum likelihood (ML) estimates of Pagel's λ statistic (Freckleton et al. 2002) for macroecological and life-history traits, with the number of species for which data are available for each trait. In each case, the likelihood ratio test described in Freckleton et al. (2002) indicated that the ML value of λ was significantly >0 ; for all traits except migration, it was also significantly <1

Trait	N	ML λ
Macroecological traits		
$\text{logit}(\text{occupancy})$	575	0.42
$\log(\text{max density})$	575	0.50
$\log(\text{mean density})$	575	0.26
$\log(\text{variation in density})$	428	0.37
Life-history traits		
Body size	324	0.83
Feeding method	125	0.62
Sociability	110	0.42
Development mode	124	0.91
Adult mobility	129	0.83
Migration	105	>0.99
Lifespan	97	0.60

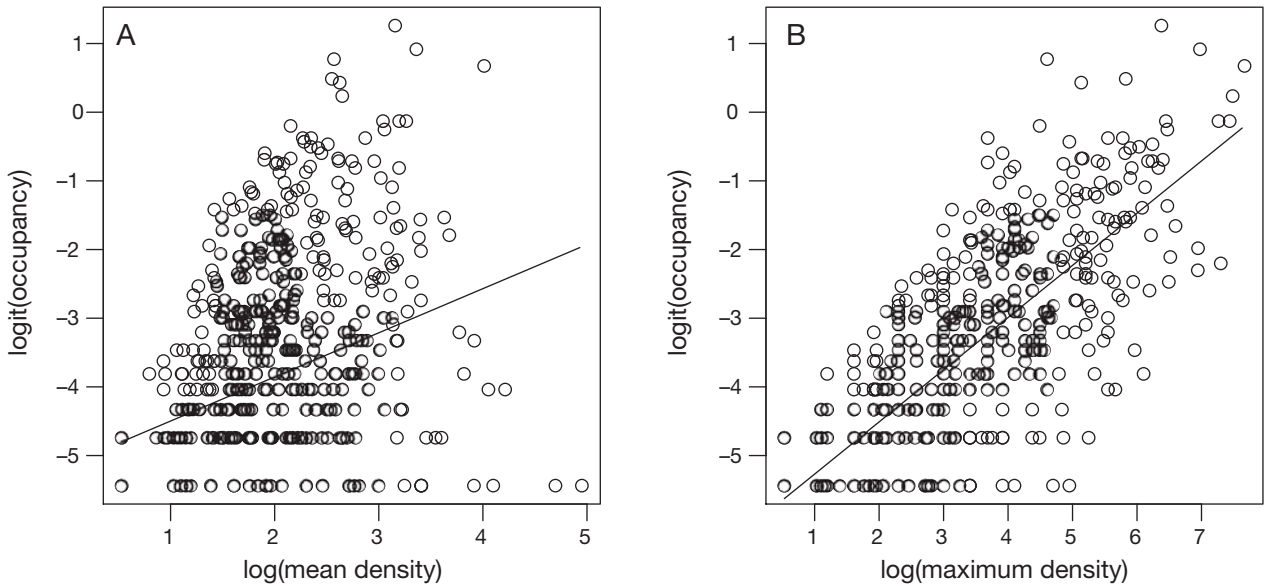

Fig. 1. Relationships between logit(occupancy) and (A) log(mean density) and (B) log(maximum density) across the 575 North Sea benthic species in our data set. The lines are fitted phylogenetically weighted generalized least squares models (see ‘Materials and methods’ for details); both relationships are significantly positive, but maximum density explains substantially more variation in occupancy ($R^2 = 0.61$) than does mean density ($R^2 = 0.10$)

0.10 and λ was estimated at 0.1875. The relationship was considerably stronger between occupancy and maximum density (Fig. 1b), with a slope of 0.76 ± 0.026 ($p < 0.0001$) and a model R^2 of 0.61. λ for this model was estimated as zero. Given that occupancy covaried so much more strongly with maximum than with mean

density, that this is generally expected (Gaston et al. 2000), and that mean and maximum density were tightly correlated across all species in our data set (correlation between log[mean density] and log[maximum density] = 0.75 across 575 species), all subsequent analyses considered only maximum density. We note,

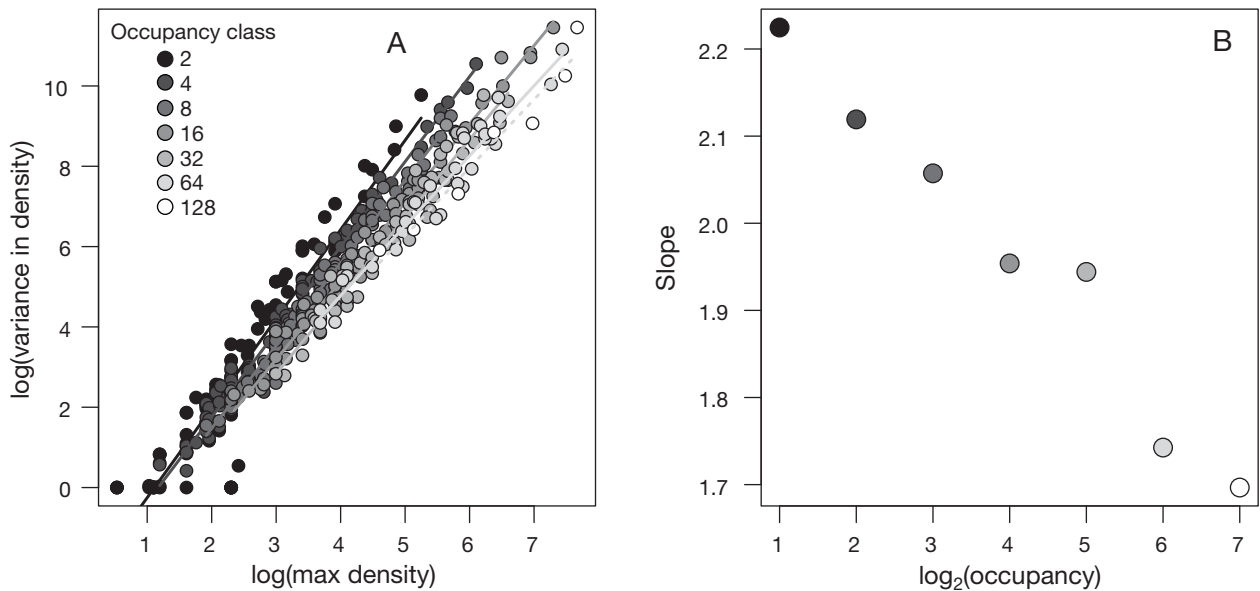

Fig. 2. (A) Relationship between log(variance in density + 1) and log(maximum density) across the 428 species that occurred in >1 sample. Species are divided into \log_2 occupancy classes; the key shows the left-hand bound of each occupancy class. For a given maximum density, variance in density increases with decreasing occupancy. What is more, the slope of the relationship between variance in density and maximum density also increases with decreasing occupancy (B), so that differences in variance between occupancy classes are more pronounced at high maximum densities. Fitted lines in (A) are colour-coded by occupancy class, with a dashed line for species with occupancy ≥ 128

however, that our results were not qualitatively affected by our choice of density measure.

Variance in density, as expected, was strongly positively correlated with maximum density (correlation between $\log[\text{maximum density}]$ and $\log[\text{variance in density} + 1] = 0.96$, $df = 426$, $p < 0.0001$). Importantly, the precise structure of this relationship varied systematically with occupancy, revealed by a linear model of $\log(\text{variance in density} + 1)$ on $\log(\text{maximum density}) \times \log_2$ occupancy class (Fig. 2). Statistically, the interaction between $\log(\text{maximum density})$ and occupancy class was highly significant ($F_{6,414} = 5.16$, $p < 0.0001$), with steeper slopes for lower occupancies (Fig. 2b). It is also clear (Fig. 2a) that for a given maximum density, variance was always higher for lower occupancies. This suggests that variation around the relationship between occupancy and maximum density is informative with respect to spatial aggregation: species with a lower occupancy than expected for a given maximum density (essentially, a negative residual from a fitted relationship between occupancy and maximum density) have a relatively higher degree of spatial clustering of individuals compared to species with a higher occupancy for the same maximum density. This is important as it allows us to use the relationship between occupancy and maximum density as a basis for testing hypotheses relating life history to spatial aggregation.

Linking life history and macroecology

Results of PGLMs linking occupancy to density and each of the 7 life-history traits listed in Table 2 are presented in Table 4. Fitted models for all traits (except lifespan) are also illustrated in Fig. 3. Of the life-history variables chosen, body size and sociability both explained significant variation in occupancy over and

above that explained by maximum density (Table 4). For body size, the trend was for the slope between occupancy and maximum density to increase with increasing body size, such that, particularly at high densities, species with large maximum sizes occurred at higher occupancies than species with smaller maximum sizes (Fig. 3). In addition, solitary species tended to have a higher occupancy for a given density than gregarious species. In terms of spatial structure, this suggests that smaller-bodied species and sociable species tend to display more spatially aggregated distributions than larger species and solitary species.

When all traits were combined into a single model, the model selection procedure failed to strongly support any one model: the 95% confidence set includes 35 models, and the most strongly supported (which included as predictors $\log[\text{maximum density}]$, body size, and sociability) had an Akaike weight of only 0.14 (indicating a 14% probability of being selected as the best model should the data collection process be repeated). However, it is clear that 2 variables occurred in almost all of these models: maximum density in all 35 and body size in 29 (83%), including the 19 highest ranked models; of the other variables, only sociability occurred in more than 50% of the 95% confidence set. Maximum density and body size also had the highest summed Akaike weights, and were the only 2 variables with probabilities of inclusion in the preferred model (of 1.0 and 0.91 respectively; Table 5) outside the 95% interval for the random, uncorrelated variable (0.24 to 0.74). Given that the single variable models also identified body size as the variable with the strongest effect on occupancy (Table 4), a reasonable compromise between model complexity and explanatory power seems to be one consisting of 2 explanatory variables only, maximum density and body size. For the 85 species used in this model selection procedure, we thus fitted a PGLM of $\text{logit}(\text{occu-}$

Table 4. Results of phylogenetically weighted generalized least squares models (PGLM) relating $\text{logit}(\text{occupancy})$ to $\log(\text{maximum density})$ and each of the life-history variables. For each model, the significance of the interaction between it and $\log(\text{maximum density})$ is given as its F value, with df and p . It is not appropriate to test trait main effects when the interaction is significant, so no data are given in this case (-). However, in the case of a non-significant interaction, the significance of the trait as a main effect (from a model including only main effects) is also shown. The ML estimate of λ from the final model (i.e. including interaction or main effects only) is also given. For all traits except migration, λ does not significantly differ from 0; for migration, λ is significantly >0 ($p = 0.0195$) but also significantly <1 ($p < 0.0001$)

Trait	ML λ	Density \times Trait interaction			Trait main effect		
		F	df	p	F	df	p
Body size	0.013	3.51	4, 314	0.0080	-	-	-
Feeding method	0.030	1.32	3, 117	0.2710	2.00	3, 120	0.1170
Sociability	0.093	0.09	1, 106	0.7636	4.30	1, 107	0.0404
Development mode	0.034	1.05	1, 120	0.3069	2.13	1, 121	0.1474
Adult mobility	0.048	0.83	3, 121	0.4812	1.53	3, 124	0.2109
Migration	0.169	0.77	1, 101	0.3826	1.38	1, 102	0.2420
Lifespan	0.039	<0.01	1, 93	0.9796	0.03	1, 194	0.8446

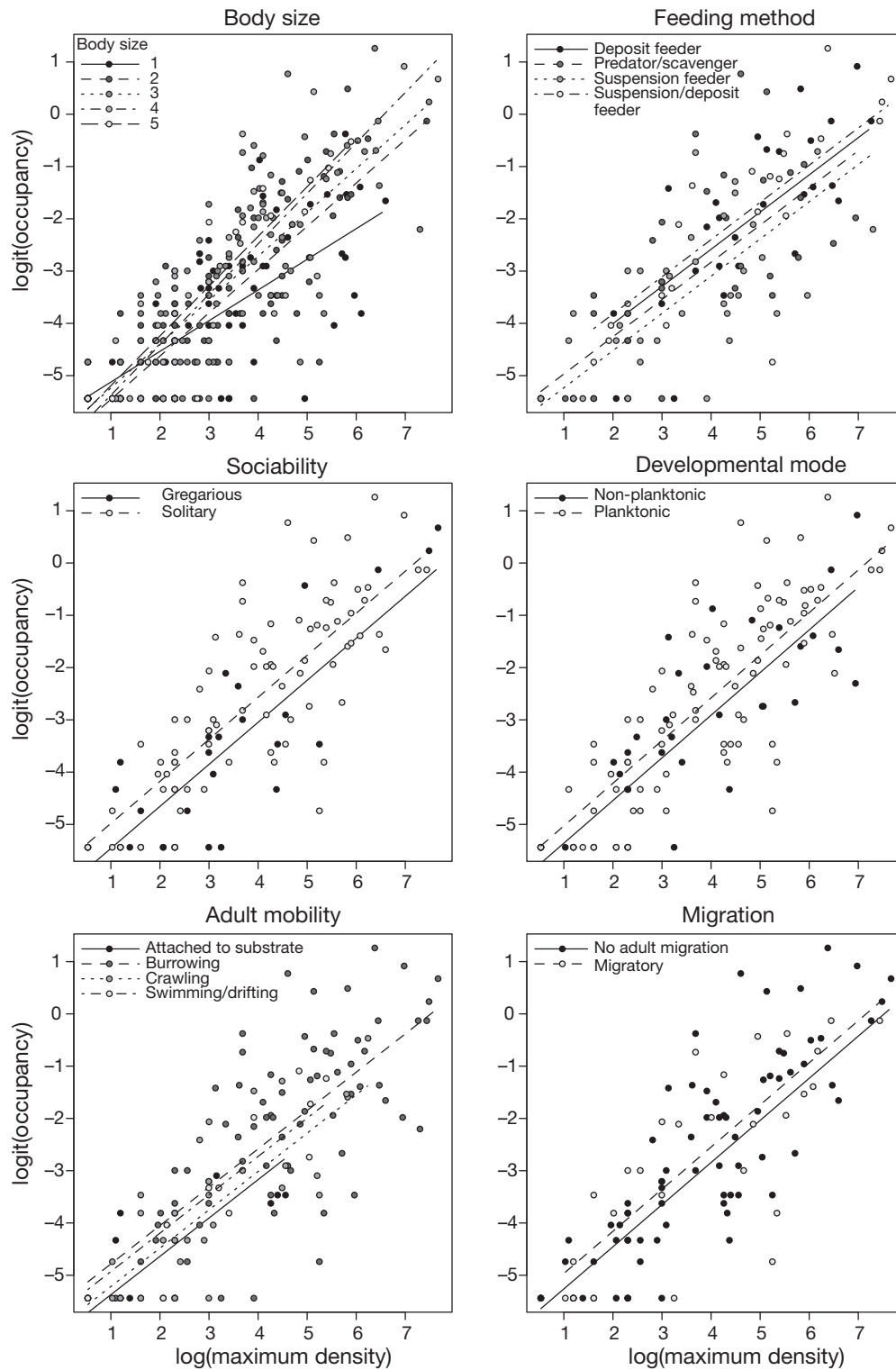

Fig. 3. Relationship between logit(occupancy) and log(maximum density) for species with different values of 6 life-history traits. Result for 'lifespan' not shown as there was little variation in lifespan between species, and clearly no effect of lifespan on the density–occupancy relationship (Table 4). Traits are explained in Table 2. Lines are fitted phylogenetically weighted generalized least squares models (PGLMs). For body size, the PGLM indicated a significant interaction between body size and log(maximum density) (Table 4), and so the lines have differing slopes. There were no significant interactions for any other traits, and so lines are parallel. Apart from sociability, none of these traits displayed a significant main effect, but we plot separate lines for each trait category to indicate the direction of any non-significant trends

Table 5. Sum of Akaike weights (w_i) of all candidate models containing each predictor variable, and the percentage of the 35 models in the 95% confidence set in which each predictor occurred, across the 85 species with data for each trait

Predictor	$\sum w_i$	Occurrence in 95% confidence set (%)
log(maximum density)	1	100
Body size	0.91	82.9
Feeding method	0.38	42.9
Development mode	0.32	48.6
Mobility	0.24	37.1
Migration	0.24	40.0
Sociability	0.63	54.3

pancy) on log(max density) + body size. Because the relationship between body size and occupancy appears to be linear, it is possible in this case to consider body size as a continuous (ordinal) covariate, with values in the range 1 to 5. This allowed us to consider its relationship with occupancy as a single 'slope', which was significantly positive (partial regression slope = 0.26 ± 0.114 , $p = 0.0268$). For comparison, log(maximum density) had a partial regression slope of 0.87 ± 0.064 ($p < 0.0001$); the model R^2 was 0.70, and λ was estimated as zero.

DISCUSSION

We documented a significant positive relationship between mean local population density and regional occupancy across 575 macrobenthic infaunal species throughout the North Sea (Fig. 1a). However, in common with previous analyses of the European macrobenthos (Webb et al. 2009), there was considerable scatter around this broad positive trend, caused primarily by a number of species which were recorded at only a single sampling station, but at a high density. Green & Plotkin (2007) show how such a result is expected when taking a relatively small number of samples of a scarce species which has a spatially aggregated distribution; most such species will not be recorded in the sampling scheme, others will be recorded at low densities, but by chance a few will be recorded only at the occasional sites where they attain high densities. These high local densities can easily exceed the mean densities of more abundant species, but are not typical for the species in question. Considering maximum densities goes some way to overcoming this sampling effect, because widespread species will always tend to occur somewhere at a higher density than that achieved even by those occasional rare species that happen to be sampled only at their highest density sites. Thus, the relationship between maximum density and regional occupancy (Fig. 1b) is considerably stronger than that between

mean density and occupancy, as has been observed previously in very different systems (e.g. British birds; Gaston et al. 2000). Indeed, Gaston et al. (2000) go as far as to suggest that the very general relationship between mean density and occupancy is driven primarily by variation in maximum density.

Importantly, the relationship between maximum local density and regional occupancy is easily interpreted in terms of the degree of spatial aggregation of individuals within species. For a given maximum density, species with a higher occupancy have a lower variance in density, and a more even, less aggregated spatial distribution (Fig. 2). Quantifying aggregation directly for British birds, using either the skewness of the distribution of densities between sites or the clumping parameter r from a negative binomial distribution fitted to this same distribution of densities, Freckleton et al. (2006) also found a significant interaction between population density and spatial aggregation in determining occupancy. The method that we adopted here allows a similar interpretation, but avoids the need to fit any parameter more complex than the sample variance to the density data, which is advantageous when many species occur at very few sites, making estimation of more complicated parameters problematic. In both cases, the implication is that the effect of any covariate which explains significant residual variation around the relationship between density and occupancy can be interpreted in terms of the spatial aggregation of individuals within species in different covariate classes.

We used a new database of life-history traits for the North Sea benthic species to test whether any of these traits could be interpreted in this way. Regardless of the exact analysis, only one of the life-history variables had a consistent effect on spatial distribution: body size (Fig. 3, Tables 4 & 5). In general, larger species have a higher occupancy for a given maximum density, and so (particularly at high maximum densities) have a less aggregated distribution than smaller-bodied species. This is the first demonstration of the effect of body size on the abundance–occupancy relationship in marine systems, and constitutes an important addition to the study of life-history correlates of large-scale population ecology (Table 1).

Body size may influence the abundance–occupancy relationship through a direct scaling relationship with dispersal ability in marine invertebrates, although it is more likely that this scaling is indirect, through correlations of body size with development mode or lifetime reproductive output (Rundle et al. 2007). Our data do suggest that such traits may have an influence on spatial distribution; for instance, the (non-significant) trend for species with planktonic larvae to be less spatially aggregated than species which lack a planktonic

dispersive phase supports the (significant) trends documented by Foggo et al. (2007). As our traits database grows, the independent roles of some of these traits may become clear. However, given that it is relatively simple to collect additional data on body size, it is interesting to consider whether it does indeed covary with the other traits. In Fig. 4 we plot for each of the other life-history traits the number of species in each trait category occurring at each body size. This shows that species with planktonic larvae are clearly larger on average than species with no planktonic phase, and it would appear too that migratory species tend to be larger on average than species which do not migrate. Thus, as suggested by Rundle et al. (2007), body size may indeed correlate with dispersal (and thus distribution and spatial aggregation) indirectly through its relationship with other life-history traits. Nevertheless, regardless of the precise causal pathway over which it acts, we suggest that body size may be a useful and robust general correlate of the spatial structure of marine benthic populations, much in the same way as it has been shown to be a useful predictor of the responses of fish populations to fishing pressure (e.g. Jennings et al. 1998). Refining estimates of body size for marine benthic taxa should therefore be a priority.

The relationship between local population density and regional occupancy usefully links population processes across spatial scales (Freckleton et al. 2005). When interpreting our analyses of the manner in which this relationship is mediated by life-history traits, however, it is important to realise that results may be influenced by the specific scales at which measurements were taken. First, our analysis is regional, with the global distributions of most component taxa extending well beyond the North Sea. As such, it is a partial rather than a comprehensive macroecological study (Blackburn & Gaston 1998), and suffers from the associated pitfalls. Of particular relevance here is the difficulty of distinguishing species which are globally rare from those which are globally widespread, but scarce in the North Sea. Databases of the distributions of macrobenthic taxa at much larger spatial scales are available (e.g. Vanden Berghe et al. 2009), but such databases lack the standard sampling design present in the North Sea, and so may confound spatial aggregation of sampling effort with spatial aggregation of organisms. This issue seems more likely to mask a real relationship between life history and spatial distribution than to create a false one, however, and so we believe that our results are robust to its effect. Of potentially more

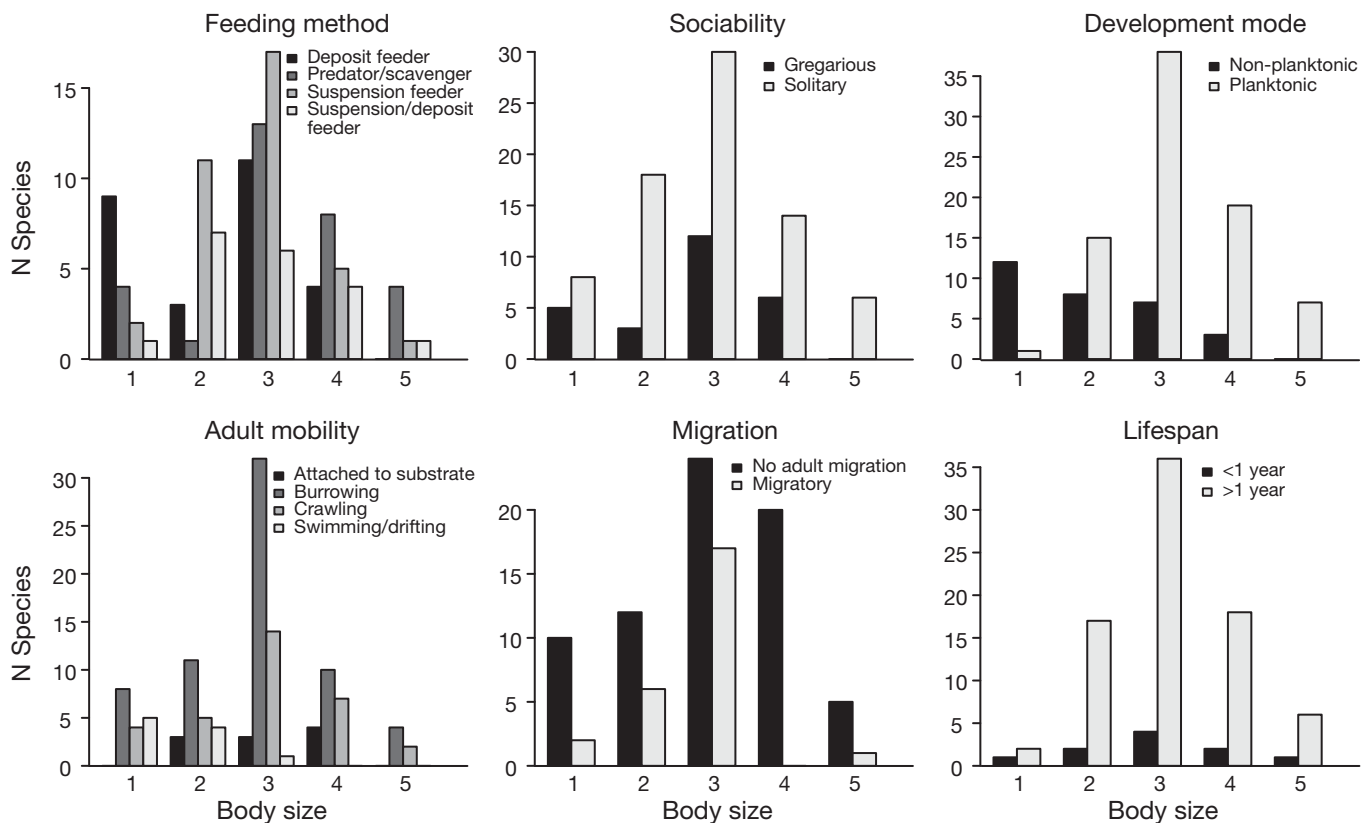

Fig. 4. Number of species displaying each category of 6 life-history traits, separated by body size. See Table 2 for details of traits and categories

concern is the possibility that patterns of local aggregation occur at different scales for species with different traits. For example, large-bodied species may aggregate at a scale somewhat larger than the typical 0.1 m² benthic sample, which would go undetected in our analysis. Such a scaling law relating regional spatial distribution to local scales of resource acquisition (e.g. Ritchie & Olff 1999) would be interesting in its own right, and suggests an interesting avenue for a more theoretical treatment of the issues dealt with here. We note, however, that all body size classes include species with both high and low local (sample-scale) abundances (see Fig. 3), which suggests that it should at least be possible to observe similar levels of aggregation across species of different sizes in our data.

Body size, in common with all the life-history traits we considered, was significantly related to taxonomic similarity (Table 3). In simple terms, this means that closely related species tended to have similar life histories. Although this is to be expected, it is still somewhat surprising to detect such strong taxonomic signals given both the use of taxonomy to approximate true evolutionary relationships, and the coarse scale of many of the life-history measurements. For instance, body size was measured as maximum recorded linear dimension, which will reflect a very different biovolume in a polychaete compared to an echinoderm. Interestingly, all of the macroecological variables we considered also had a significant taxonomic signal (Table 3), although values of λ were typically lower than those estimated for life-history traits. This is consistent with previous studies that have shown that biogeographical and macroecological variables typically have a lower phylogenetic signal than most life-history variables (e.g. Freckleton et al. 2002). For life-history variables in particular, the taxonomic signal we documented raises the possibility of imputing missing trait data for a species based on information recorded for its relatives. A caveat to this, however, is that the availability of data is itself related to taxonomy. This can be shown by scoring the number of traits for which we have data for each species (which across our entire database varies between 0 and 15), and then estimating taxonomic signal in this 'number of traits' variable. This results in a maximum likelihood value of 0.61, which is both significantly >0 and significantly <1 . In other words, our biological knowledge of the North Sea benthos is taxonomically biased, and our results must be considered with this in mind.

Finally, we acknowledge that we have not in the present study explicitly considered the biophysical characteristics of different habitats within the North Sea, or the spatial distribution of human impacts including fisheries and pollution. Clearly, such factors play an

important, even dominant, role in driving the composition of soft-sediment benthic communities (e.g. Gray & Elliott 2009). Ultimately, it is the responses of species with different biological traits to these biophysical and anthropogenic drivers that results in the patterns that we have observed. The fact that we do detect a role for life history in mediating the interactions between local- and regional-scale processes suggests, however, that understanding the biological traits of species can help us to predict their ecological responses to changing environmental conditions.

CONCLUSIONS

We have shown how data on the biological traits of benthic taxa can be combined with macroecological techniques to gain insight into the large-scale spatial ecology of marine assemblages. In particular, the relationship between local population density and regional occupancy offers a framework with a strong empirical and theoretical basis with which to interpret patterns in the spatial distribution of marine species. Adding covariates to these analyses has revealed that body size appears to play an important role in mediating the abundance–occupancy relationship in the North Sea benthos, adding valuable data to the limited literature on life-history correlates of large-scale population ecology. Determining whether this effect is direct, for instance through the role of body size on trophic interactions, or indirect, through body size effects on other life-history traits including dispersal and reproductive potential, promises to be a fruitful avenue for future research. Finally, the present study shows again the benefits of compiling targeted large-scale data sets to drive forward fundamental and applied marine biodiversity research.

Acknowledgements. We thank M. Solan for the invitation to contribute to this Theme Section, and J. Bremner and H. Tillin for providing access to their biological traits databases. We also acknowledge staff at the Marine Biological Association who assisted in data collection, particularly E. Jackson and O. Langmead (MarLIN) and L. Noble (National Marine Biological Library). This work was funded by NERC through a Strategic Oceans Funding Initiative grant to T.J.W. and P.J.S. P.J.S. acknowledges funding from Defra (Project ME3109). T.J.W. is a Royal Society Research Fellow.

LITERATURE CITED

- Atkinson D, Hirst AG (2007) Life histories and body size. In: Hildrew AG, Raffaelli DG, Edmonds-Brown R (eds) *Body size: the structure and function of aquatic ecosystems*. Cambridge University Press, Cambridge, p 33–54
- Blackburn TM, Gaston KJ (1998) Some methodological issues in macroecology. *Am Nat* 151:68–83

- Blackburn TM, Cassey P, Gaston KJ (2006) Variations on a theme: sources of heterogeneity in the form of the interspecific relationship between abundance and distribution. *J Anim Ecol* 75:1426–1439
- Bremner J, Rogers SI, Frid CLJ (2003) Assessing functional diversity in marine benthic ecosystems: a comparison of approaches. *Mar Ecol Prog Ser* 254:11–25
- Bremner J, Rogers SI, Frid CLJ (2006) Methods for describing ecological functioning of marine benthic assemblages using biological traits analysis (BTA). *Ecol Indic* 6:609–622
- Burnham KP, Anderson DR (2002) Model selection and multimodel inference. Springer, New York
- Clarke KR, Chapman MG, Somerfield PJ, Needham HR (2006) Dispersion-based weighting of species counts in assemblage analyses. *Mar Ecol Prog Ser* 320:11–27
- Clarke A, Griffiths HJ, Linse K, Barnes DKA, Crame JA (2007) How well do we know the Antarctic marine fauna? A preliminary study of macroecological and biogeographical patterns in Southern Ocean gastropod and bivalve molluscs. *Divers Distrib* 13:620–632
- Cowley MJR, Thomas CD, Roy DB, Wilson RJ and others (2001) Density–distribution relationships in British butterflies. I. The effect of mobility and spatial scale. *J Anim Ecol* 70:410–425
- Craeymeersch JA, Heip CHR, Buijs J (1997) Atlas of North Sea benthic infauna. Based on the 1986 North Sea benthos survey. ICES Coop Res Rep 218, ICES, Copenhagen
- Faraway JJ (2005) Extending the linear model with R: generalized linear, mixed effects and nonparametric regression models. Chapman & Hall/CRC, Boca Raton, FL
- Foggo A, Frost MT, Attrill MJ (2003) Abundance–occupancy patterns in British estuarine macroinvertebrates. *Mar Ecol Prog Ser* 265:297–302
- Foggo A, Bilton DT, Rundle SD (2007) Do developmental mode and dispersal shape abundance–occupancy relationships in marine macroinvertebrates? *J Anim Ecol* 76:695–702
- Freckleton RP, Harvey PH, Pagel M (2002) Phylogenetic analysis and comparative data: a test and review of evidence. *Am Nat* 160:712–726
- Freckleton RP, Gill JA, Noble D, Watkinson AR (2005) Large-scale population dynamics, abundance–occupancy relationships and the scaling from local to regional population size. *J Anim Ecol* 74:353–364
- Freckleton RP, Noble D, Webb TJ (2006) Distributions of habitat suitability and the abundance–occupancy relationship. *Am Nat* 167:260–275
- Gaston KJ, Blackburn TM (2003) Dispersal and the interspecific abundance–occupancy relationship in British birds. *Glob Ecol Biogeogr* 12:373–379
- Gaston KJ, Blackburn TM, Greenwood JJD, Gregory RD, Quinn RM, Lawton JH (2000) Abundance–occupancy relationships. *J Appl Ecol* 37:39–59
- Gray JS, Elliott M (2009) Ecology of marine sediments, 2nd edn. Oxford University Press, Oxford
- Green JL, Plotkin JB (2007) A statistical theory for sampling species abundances. *Ecol Lett* 10:1037–1045
- Halpern BS, Walbridge S, Selkoe KA, Kappel CV and others (2008) A global map of human impact on marine ecosystems. *Science* 319:948–952
- Harte J, Conlisk E, Ostling A, Green JL, Smith AB (2005) A theory of spatial structure in ecological communities at multiple spatial scales. *Ecol Monogr* 75:179–197
- Harvey PH, Pagel MD (1991) The comparative method in evolutionary biology. Oxford University Press, Oxford
- Hayward PJ, Ryland JS (1991a) The marine fauna of the British Isles and North-West Europe. Vol I: introduction and protozoans to arthropods. Oxford University Press, Oxford
- Hayward PJ, Ryland JS (1991b) The marine fauna of the British Isles and North-West Europe. Vol II: molluscs to chordates. Oxford University Press, Oxford
- Heino J (2005) Positive relationship between regional distribution and local abundance in stream insects: a consequence of niche breadth or niche position? *Ecography* 28:345–354
- Heip C, Basford D, Craeymeersch JA, Dewarumez JM and others (1992) The benthic communities of the North Sea: a summary of the results of the North Sea Benthos Survey. ICES Coop Res Rep 190:148–175
- Hendriks IE, Duarte CM, Heip CHR (2006) Biodiversity research still grounded. *Science* 312:1715
- Hildrew AG, Raffaelli DG, Edmonds-Brown R (eds) (2007) Body size: the structure and function of aquatic ecosystems. Cambridge University Press, Cambridge
- Holt AR, Gaston KJ (2003) Interspecific abundance–occupancy relationships of British mammals and birds: Is it possible to explain the residual variation? *Glob Ecol Biogeogr* 12:37–46
- Holt AR, Gaston KJ, He F (2002) Occupancy–abundance relationships and spatial distribution: a review. *Basic Appl Ecol* 3:1–13
- ICES (1986) Fifth report of the Benthos Ecology Working Group, Ostende, 12–15 May 1986. ICES CM 1986 C:27, ICES, Copenhagen
- Jablonski D (1986) Larval ecology and macroevolution in marine invertebrates. *Bull Mar Sci* 39:565–587
- Jennings S, Reynolds JD, Mills SC (1998) Life history correlates of responses to fisheries exploitation. *Proc R Soc Lond B Biol Sci* 265:333–339
- Jennings S, Mélin F, Blanchard JL, Forster RM, Dulvy NK, Wilson RW (2008) Global-scale predictions of community and ecosystem properties from simple ecological theory. *Proc R Soc Lond B Biol Sci* 275:1375–1383
- Johnson JB, Omland KE (2004) Model selection in ecology and evolution. *Trends Ecol Evol* 19:101–108
- Kerr JT, Kharouba HM, Currie DJ (2007) The macroecological contribution to global change solutions. *Science* 316:1581–1584
- Leger EA, Forister ML (2009) Colonization, abundance, and geographic range size of gravestone lichens. *Basic Appl Ecol* 10:279–287
- May RM (1994) Biological diversity: differences between land and sea. *Philos Trans R Soc Lond B Biol Sci* 343:105–111
- Murray BR, Hose GC (2005) The interspecific range size–body size relationship in Australian frogs. *Glob Ecol Biogeogr* 14:339–345
- Nakagawa S, Freckleton RP (2008) Missing inaction: the dangers of ignoring missing data. *Trends Ecol Evol* 23:592–596
- Orme D, Freckleton R, Thomas G (2008) CAIC: comparative analyses using independent contrasts. R package version 1.0.4–83 available at <http://r-forge.r-project.org/projects/caic>
- Patil GP, Stiteler WM (1973) Concepts of aggregation and their quantification: a critical review with some new results and applications. *Res Popul Ecol* 15:238–254
- Peters RH (1983) The ecological implications of body size. Cambridge University Press, Cambridge
- Purvis A, Hector A (2000) Getting the measure of biodiversity. *Nature* 405:212–219
- Quinn GP, Keough MJ (2002) Experimental design and data analysis for biologists. Cambridge University Press, Cambridge

- R Development Core Team (2008) R: A language and environment for statistical computing. Available at www.R-project.org
- Raffaelli D, Solan M, Webb TJ (2005) Do marine and terrestrial ecologists do it differently? *Mar Ecol Prog Ser* 304: 283–289
- Richardson AJ, Poloczanska ES (2008) Ocean science: under-resourced, under threat. *Science* 320:1294–1295
- Ritchie ME, Olf H (1999) Spatial scaling laws yield a synthetic theory of biodiversity. *Nature* 400:557–560
- Rundle SD, Bilton DT, Foggo A (2007) By wind, wings or water: body size, dispersal and range size in aquatic invertebrates. In: Hildrew AG, Raffaelli DG, Edmonds-Brown R (eds) *Body size: the structure and function of aquatic ecosystems*. Cambridge University Press, Cambridge, p 186–209
- Tjørve E, Kunin WE, Polce C, Calf Tjørve KM (2008) Species–area relationship: separating the effects of species abundance and spatial distribution. *J Ecol* 96:1141–1151
- Vanden Berghe E, Claus S, Appeltans W, Faulwetter S and others (2009) MacroBen integrated database on benthic invertebrates of European continental shelves: a tool for large-scale analysis across Europe. *Mar Ecol Prog Ser* 382: 225–238
- Webb TJ (2009) Biodiversity research sets sail: showcasing the diversity of marine life. *Biol Lett* 5:145–147
- Webb TJ, Woodward FI, Hannah L, Gaston KJ (2005) Forest cover–rainfall relationships in a biodiversity hotspot: the Atlantic Forest of Brazil. *Ecol Appl* 15:1968–1983
- Webb TJ, Noble D, Freckleton RP (2007) Abundance–occupancy dynamics in a human dominated environment: linking interspecific and intraspecific trends in British farmland and woodland birds. *J Anim Ecol* 76:123–134
- Webb TJ, Aleffi IF, Amouroux JM, Bachelet G and others (2009) Macroecology of the European soft sediment benthos: insights from the MacroBen database. *Mar Ecol Prog Ser* 382:287–296
- Williamson M, Gaston KJ (1999) A simple transformation for sets of range sizes. *Ecography* 22:674–680
- Worm B, Barbier EB, Beaumont N, Duffy JE and others (2006) Impacts of biodiversity loss on ocean ecosystem services. *Science* 314:787–790

Submitted: May 11, 2009; Accepted: July 30, 2009

Proofs received from author(s): November 27, 2009