

# **3DLDF User and Reference Manual**

---

3-dimensional drawing with MetaPost output.  
Manual edition 1.1.5.1 for 3DLDF Version 1.1.5.1  
July 2007

**Laurence D. Finston**

---

This is the 3DLDF User and Reference Manual, edition 1.1.5.1 for 3DLDF 1.1.5.1. This manual was last updated on 18 July 2007. 3DLDF is a GNU package for three-dimensional drawing with MetaPost output. The author is Laurence D. Finston.

Copyright © 2003, 2004, 2005, 2006, 2007 The Free Software Foundation

Permission is granted to copy, distribute and/or modify this document under the terms of the GNU Free Documentation License, Version 1.2 or any later version published by the Free Software Foundation; with no Invariant Sections, no Front-Cover Texts, and no Back-Cover Texts. A copy of the license is included in the section entitled “GNU Free Documentation License”.

## Short Contents

1	Introduction . . . . .	1
2	Points . . . . .	10
3	Transforming Points . . . . .	13
4	Transforms . . . . .	18
5	Drawing and Labeling Points . . . . .	23
6	Paths . . . . .	27
7	Plane Figures . . . . .	35
8	Solid Figures . . . . .	46
9	Pictures . . . . .	53
10	Intersections . . . . .	72
11	Installing and Running 3DLDF . . . . .	73
12	Typedefs and Utility Structures . . . . .	80
13	Global Constants and Variables . . . . .	81
14	Dynamic Allocation of Shapes . . . . .	83
15	System Information . . . . .	84
16	Color Reference . . . . .	87
17	Input and Output . . . . .	91
18	Shape Reference . . . . .	92
19	Transform Reference . . . . .	95
20	Label Reference . . . . .	107
21	Picture Reference . . . . .	110
22	Point Reference . . . . .	118
23	Focus Reference . . . . .	150
24	Line Reference . . . . .	153
25	Plane Reference . . . . .	156
26	Path Reference . . . . .	164
27	Polygon Reference . . . . .	198
28	Regular Polygon Reference . . . . .	204
29	Rectangle Reference . . . . .	210
30	Regular Closed Plane Curve Reference . . . . .	215
31	Ellipse Reference . . . . .	221
32	Circle Reference . . . . .	237
33	Pattern Reference . . . . .	241
34	Solid Reference . . . . .	247
35	Faced Solid Reference . . . . .	256

36	Cuboid Reference . . . . .	257
37	Polyhedron Reference . . . . .	259
38	Utility Functions . . . . .	270
39	Adding a File . . . . .	272
40	Future Plans . . . . .	274
41	Changes . . . . .	277
	Bibliography . . . . .	279
A	GNU Free Documentation License . . . . .	281
	Data Type and Variable Index . . . . .	288
	Function Index . . . . .	291
	Concept Index . . . . .	294

# Table of Contents

<b>1</b>	<b>Introduction</b> .....	<b>1</b>
1.1	Sources of Information .....	1
1.2	About This Manual .....	2
1.2.1	Conventions .....	3
1.2.2	Illustrations .....	4
1.3	CWEB Documentation .....	5
1.4	Metafont and MetaPost .....	6
1.5	Caveats .....	7
1.5.1	Accuracy .....	7
1.5.2	No Input Routine .....	8
1.6	Ports .....	8
1.7	Contributing to 3DLDF .....	9
<b>2</b>	<b>Points</b> .....	<b>10</b>
2.1	Declaring and Initializing Points .....	10
2.2	Setting and Assigning to Points .....	11
<b>3</b>	<b>Transforming Points</b> .....	<b>13</b>
3.1	Shifting .....	13
3.2	Scaling .....	14
3.3	Shearing .....	14
3.4	Rotating .....	15
<b>4</b>	<b>Transforms</b> .....	<b>18</b>
4.1	Applying Transforms to Points .....	19
4.2	Inverting Transforms .....	20
<b>5</b>	<b>Drawing and Labeling Points</b> .....	<b>23</b>
5.1	Drawing Points .....	23
5.2	Labeling Points .....	25
<b>6</b>	<b>Paths</b> .....	<b>27</b>
6.1	Declaring and Initializing Paths .....	27
6.2	Drawing and Filling Paths .....	29
<b>7</b>	<b>Plane Figures</b> .....	<b>35</b>
7.1	Regular Polygons .....	35
7.2	Rectangles .....	38
7.3	Ellipses .....	42
7.4	Circles .....	44

<b>8</b>	<b>Solid Figures</b> .....	<b>46</b>
8.1	Cuboids .....	46
8.2	Polyhedron .....	47
8.2.1	Tetrahedron .....	47
8.2.2	Dodecahedron .....	48
8.2.3	Icosahedron .....	50
<b>9</b>	<b>Pictures</b> .....	<b>53</b>
9.1	Projections .....	57
9.1.1	Parallel Projections .....	57
9.1.2	The Perspective Projection .....	59
9.2	Focuses .....	62
9.3	Surface Hiding .....	65
<b>10</b>	<b>Intersections</b> .....	<b>72</b>
<b>11</b>	<b>Installing and Running 3DLDF</b> .....	<b>73</b>
11.1	Installing 3DLDF .....	73
11.1.1	Template Functions .....	73
11.2	Running 3DLDF .....	74
11.2.1	Converting EPS Files .....	76
11.2.1.1	Emacs-Lisp Functions .....	77
11.2.2	Command Line Arguments .....	78
<b>12</b>	<b>Typedefs and Utility Structures</b> .....	<b>80</b>
<b>13</b>	<b>Global Constants and Variables</b> .....	<b>81</b>
<b>14</b>	<b>Dynamic Allocation of Shapes</b> .....	<b>83</b>
<b>15</b>	<b>System Information</b> .....	<b>84</b>
15.1	Endianness .....	84
15.2	Register Width .....	85
15.3	Get Second Largest Real .....	85
<b>16</b>	<b>Color Reference</b> .....	<b>87</b>
16.1	Data Members .....	87
16.2	Constructors and Setting Functions .....	87
16.3	Operators .....	88
16.4	Modifying .....	88
16.5	Showing .....	89
16.6	Querying .....	89
16.7	Defining and Initializing Colors .....	89
16.8	Namespace Colors .....	89

<b>17</b>	<b>Input and Output</b> .....	<b>91</b>
17.1	Global Variables .....	91
17.2	I/O Functions .....	91
<b>18</b>	<b>Shape Reference</b> .....	<b>92</b>
18.1	Data Members .....	92
18.2	Operators .....	92
18.3	Copying .....	92
18.4	Modifying .....	92
18.5	Affine Transformations .....	93
18.6	Applying Transformations .....	93
18.7	Clearing .....	93
18.8	Querying .....	93
18.9	Showing .....	93
18.10	Outputting .....	93
<b>19</b>	<b>Transform Reference</b> .....	<b>95</b>
19.1	Data Members .....	95
19.2	Global Variables and Constants .....	95
19.3	Constructors .....	95
19.4	Operators .....	95
19.5	Matrix Inversion .....	98
19.6	Setting Values .....	98
19.7	Querying .....	98
19.8	Returning Information .....	99
19.9	Showing .....	99
19.10	Affine Transformations .....	100
19.11	Alignment with an Axis .....	104
19.12	Resetting .....	106
19.13	Cleaning .....	106
<b>20</b>	<b>Label Reference</b> .....	<b>107</b>
20.1	Data Members .....	107
20.2	Copying .....	108
20.3	Outputting .....	108

<b>21</b>	<b>Picture Reference</b> .....	<b>110</b>
21.1	Data Members .....	110
21.2	Global Variables .....	110
21.3	Constructors .....	110
21.4	Operators .....	111
21.5	Affine Transformations .....	112
21.6	Modifying .....	112
21.7	Showing .....	113
21.8	Outputting .....	113
21.8.1	Namespaces .....	113
21.8.1.1	Namespace Projections .....	113
21.8.1.2	Namespace Sorting .....	113
21.8.2	Output Functions .....	114
<b>22</b>	<b>Point Reference</b> .....	<b>118</b>
22.1	Data Members .....	118
22.2	Typedefs and Utility Structures .....	120
22.3	Global Constants and Variables .....	121
22.4	Constructors and Setting Functions .....	121
22.5	Destructor .....	122
22.6	Operators .....	123
22.7	Copying .....	125
22.8	Querying .....	125
22.9	Returning Coordinates .....	126
22.10	Returning Information .....	128
22.11	Modifying .....	128
22.12	Affine Transformations .....	129
22.13	Applying Transformations .....	134
22.14	Projecting .....	134
22.15	Vector Operations .....	134
22.16	Points and Lines .....	139
22.17	Intersections .....	142
22.18	Drawing .....	143
22.19	Labelling .....	146
22.20	Showing .....	148
22.21	Outputting .....	148
<b>23</b>	<b>Focus Reference</b> .....	<b>150</b>
23.1	Data Members .....	150
23.2	Global Variables .....	150
23.3	Constructors and Setting Functions .....	151
23.4	Operators .....	151
23.5	Modifying .....	151
23.6	Querying .....	152
23.7	Showing .....	152



<b>24</b>	<b>Line Reference</b> .....	<b>153</b>
24.1	Data Members .....	153
24.2	Global Constants .....	153
24.3	Constructors .....	153
24.4	Operators .....	154
24.5	Get Path .....	154
24.6	Showing .....	154
<b>25</b>	<b>Plane Reference</b> .....	<b>156</b>
25.1	Data Members .....	156
25.2	Global Constants .....	156
25.3	Constructors .....	156
25.4	Operators .....	157
25.5	Returning Information .....	158
25.6	Intersections .....	159
25.7	Showing .....	162
<b>26</b>	<b>Path Reference</b> .....	<b>164</b>
26.1	Data Members .....	164
26.2	Constructors and Setting Functions .....	166
26.3	Destructor .....	170
26.4	Operators .....	170
26.5	Appending .....	171
26.6	Copying .....	172
26.7	Clearing .....	172
26.8	Modifying .....	172
26.9	Affine Transformations .....	173
26.10	Aligning with an Axis .....	177
26.11	Applying Transformations .....	179
26.12	Drawing and Filling .....	179
26.13	Labelling .....	190
26.14	Showing .....	191
26.15	Querying .....	193
26.16	Outputting .....	195
26.17	Intersections .....	196
<b>27</b>	<b>Polygon Reference</b> .....	<b>198</b>
27.1	Data Members .....	198
27.2	Operators .....	198
27.3	Querying .....	198
27.4	Affine Transformations .....	198
27.5	Intersections .....	199

<b>28</b>	<b>Regular Polygon Reference</b> . . . . .	<b>204</b>
28.1	Data Members . . . . .	204
28.2	Constructors and Setting Functions . . . . .	204
28.3	Operators . . . . .	206
28.4	Querying . . . . .	206
28.5	Circles . . . . .	206
<b>29</b>	<b>Rectangle Reference</b> . . . . .	<b>210</b>
29.1	Data Members . . . . .	210
29.2	Constructors and Setting Functions . . . . .	210
29.3	Operators . . . . .	211
29.4	Returning Points . . . . .	211
29.5	Querying . . . . .	212
29.6	Ellipses . . . . .	212
<b>30</b>	<b>Regular Closed Plane Curve Reference</b> . . . . .	<b>215</b>
30.1	Data Members . . . . .	215
30.2	Querying . . . . .	215
30.3	Intersections . . . . .	216
30.4	Segments . . . . .	218
<b>31</b>	<b>Ellipse Reference</b> . . . . .	<b>221</b>
31.1	Data Members . . . . .	221
31.2	Constructors and Setting Functions . . . . .	221
31.3	Performing Transformations . . . . .	223
31.4	Operators . . . . .	223
31.5	Labeling . . . . .	223
31.6	Affine Transformations . . . . .	225
31.7	Querying . . . . .	225
31.8	Returning Elements and Information . . . . .	226
31.9	Intersections . . . . .	229
31.10	Solving . . . . .	234
31.11	Rectangles . . . . .	235
<b>32</b>	<b>Circle Reference</b> . . . . .	<b>237</b>
32.1	Data Members . . . . .	237
32.2	Constructors and Setting Functions . . . . .	237
32.3	Operators . . . . .	237
32.4	Querying . . . . .	238
32.5	Intersections . . . . .	239
<b>33</b>	<b>Pattern Reference</b> . . . . .	<b>241</b>
33.1	Plane Tessellations . . . . .	241
33.2	Roulettes and Involutés . . . . .	243
33.2.1	Epicycloids . . . . .	244

<b>34</b>	<b>Solid Reference</b> .....	<b>247</b>
34.1	Data Members .....	247
34.2	Constructors and Setting Functions .....	247
34.3	Destructor .....	248
34.4	Operators .....	248
34.5	Copying .....	248
34.6	Setting Members .....	248
34.7	Querying .....	249
34.8	Returning Elements and Information .....	249
	Getting Shape Centers .....	249
	Getting Shapes .....	250
34.9	Showing .....	252
34.10	Affine Transformations .....	252
34.11	Applying Transformations .....	253
34.12	Outputting .....	253
34.13	Drawing and Filling .....	254
34.14	Clearing .....	255
<b>35</b>	<b>Faced Solid Reference</b> .....	<b>256</b>
35.1	Data Members .....	256
<b>36</b>	<b>Cuboid Reference</b> .....	<b>257</b>
36.1	Data Members .....	257
36.2	Constructors and Setting Functions .....	257
36.3	Operators .....	258
<b>37</b>	<b>Polyhedron Reference</b> .....	<b>259</b>
37.1	Data Members .....	259
37.2	Regular Platonic Polyhedra .....	259
	37.2.1 Tetrahedron .....	259
	37.2.1.1 Data Members .....	259
	37.2.1.2 Constructors and Setting Functions ..	259
	37.2.1.3 Net .....	261
	37.2.2 Dodecahedron .....	263
	37.2.2.1 Data Members .....	263
	37.2.2.2 Constructors and Setting Functions ..	263
	37.2.2.3 Net .....	264
	37.2.3 Icosahedron .....	265
	37.2.3.1 Data Members .....	265
	37.2.3.2 Constructors and Setting Functions ..	265
	37.2.3.3 Net .....	266
37.3	Semi-Regular Archimedean Polyhedra .....	268
	37.3.1 Truncated Octahedron .....	268
	37.3.1.1 Data Members .....	268
	37.3.1.2 Constructors and Setting Functions ..	268
	37.3.1.3 Net .....	269

<b>38</b>	<b>Utility Functions</b> .....	<b>270</b>
	38.1 Perspective Functions .....	270
<b>39</b>	<b>Adding a File</b> .....	<b>272</b>
<b>40</b>	<b>Future Plans</b> .....	<b>274</b>
	40.1 Geometry .....	274
	40.2 Curves and Surfaces .....	274
	40.3 Shadows, Reflections, and Rendering .....	275
	40.4 Multi-Threading .....	276
<b>41</b>	<b>Changes</b> .....	<b>277</b>
	41.1 3DLDF 1.1.5.1 .....	277
	41.2 3DLDF 1.1.5 .....	277
	41.3 3DLDF 1.1.4.2 .....	278
	41.4 3DLDF 1.1.4.1 .....	278
	41.5 3DLDF 1.1.4 .....	278
	41.6 3DLDF 1.1.1 .....	278
	<b>Bibliography</b> .....	<b>279</b>
	<b>Appendix A GNU Free Documentation License</b> .....	<b>281</b>
	A.0.1 ADDENDUM: How to use this License for your documents .....	287
	<b>Data Type and Variable Index</b> .....	<b>288</b>
	<b>Function Index</b> .....	<b>291</b>
	<b>Concept Index</b> .....	<b>294</b>

# 1 Introduction

3DLDF is a free software package for three-dimensional drawing written by Laurence D. Finston, who is also the author of this manual. It is written in C++ using CWEB and it outputs MetaPost code.

3DLDF is a GNU package. It is part of the GNU Project of the Free Software Foundation and is published under the GNU General Public License. See the website <http://www.gnu.org> for more information. 3DLDF is available for downloading from <http://ftp.gnu.org/gnu/3dldf>. The official 3DLDF website is <http://www.gnu.org/software/3dldf>. More information about 3DLDF can be found at the author's website: <http://wwwuser.gwdg.de/~lfinsto1>.

Please send bug reports to:

[bug-3DLDF@gnu.org](mailto:bug-3DLDF@gnu.org) and

Two other mailing lists may be of interest to users of 3DLDF: [help-3DLDF@gnu.org](mailto:help-3DLDF@gnu.org) is for people to ask other users for help and [info-3DLDF@gnu.org](mailto:info-3DLDF@gnu.org) is for sending announcements to users. To subscribe, send an email to the appropriate mailing list or lists with the word "subscribe" as the subject. The author's website is <http://wwwuser.gwdg.de/~lfinsto1>.

My primary purpose in writing 3DLDF was to make it possible to use MetaPost for three-dimensional drawing. I've always enjoyed using MetaPost, and thought it was a shame that I could only use it for making two-dimensional drawings. 3DLDF is a front-end that operates on three-dimensional data, performs the necessary calculations for the projection onto two dimensions, and writes its output in the form of MetaPost code.

While 3DLDF's data types and operations are modelled on those of Metafont and MetaPost, and while the only form of output 3DLDF currently produces is MetaPost code, it is nonetheless not in principle tied to MetaPost. It could be modified to produce PostScript code directly, or output in other formats. It would also be possible to modify 3DLDF so that it could be used for creating graphics interactively on a terminal, by means of an appropriate interface to the computer's graphics hardware.

The name "3DLDF" ("3D" plus the author's initials) was chosen because, while not pretty, it's unlikely to conflict with any of the other programs called "3D"-something.

## 1.1 Sources of Information

This handbook, and the use of 3DLDF itself, presuppose at least some familiarity on the part of the reader with Metafont, MetaPost, CWEB, and C++. If you are not familiar with any or all of them, I recommend the following sources of information:

Knuth, Donald Ervin. *The METAFONTbook*. Computers and Typesetting; C. Addison Wesley Publishing Company, Inc. Reading, Massachusetts 1986.

Hobby, John D. *A User's Manual for MetaPost*. AT & T Bell Laboratories. Murray Hill, NJ. No date.

Knuth, Donald E. and Silvio Levy. *The CWEB System of Structured Documentation*. Version 3.64—February 2002.

Stroustrup, Bjarne. *The C++ Programming Language*. Special Edition. Reading, Massachusetts 2000. Addison-Wesley. ISBN 0-201-70073-5.

The manuals for MetaPost and CWEB are available from the Comprehensive T<sub>E</sub>X Archive Network (CTAN). See one of the following web sites for more information:

Germany <http://dante.ctan.org>, <http://ftp.dante.de>  
<http://www.dante.de>.

United Kingdom  
<http://www.cam.ctan.org>  
<http://ftp.tex.ac.uk>.

USA <http://www.tug.ctan.org>  
<http://www.ctan.tug.org>.

## 1.2 About This Manual

This manual has been created using Texinfo, a documentation system which is part of the GNU Project, whose main sponsor is the Free Software Foundation. Texinfo can be used to generate online and printed documentation from the same input files.

For more information about Texinfo, see:

Stallmann, Richard M. and Robert J. Chassell. *Texinfo. The GNU Documentation Format*. The Free Software Foundation. Boston 1999.

For more information about the GNU Project and the Free Software Foundation, see the following web site: <http://www.gnu.org>.

The edition of this manual is 1.1.5.1 and it documents version 1.1.5.1 of 3DLDF. The edition number of the manual and the version number of the program are the same (as of 18 July 2007), but may diverge at a later date.

Note that “I”, “me”, etc., in this manual refers to Laurence D. Finston, so far the sole author of both 3DLDF and this manual. “Currently” and similar formulations refer to version 1.1.5.1 of 3DLDF as of 18 July 2007.

This manual is intended for both beginning and advanced users of 3DLDF. So, if there’s something you don’t understand, it’s probably best to skip it and come back to it later. Some of the more difficult points, or ones that presuppose familiarity with features not yet described, are in the footnotes.

I firmly believe that an adequate program with good documentation is more useful than a great program with poor or no documentation. The ideal case, of course, is a great program with great documentation. I’m sorry to say, that this manual is not yet as good as I’d like it to be. I apologize for the number of typos and other errors. I hope they don’t detract too much from its usefulness. I would have liked to have proofread and corrected it again before publication, but for reasons external to 3DLDF, it is necessary for me to publish now. I plan to set up an errata list on the official 3DLDF website (<http://www.gnu.org/software/3dldf>), and/or my own website (<http://wwwuser.gwdg.de/~lfinsto1>).

Unless I've left anything out by mistake, this manual documents all of the data types, constants and variables, namespaces, and functions defined in 3DLDF. However, some of the descriptions are terser than I would like, and I'd like to have more examples and illustrations. There is also more to be said on a number of topics touched on in this manual, and some topics I haven't touched on at all. In general, while I've tried to give complete information on the "what and how", the "why and wherefore" has sometimes gotten short shrift. I hope to correct these defects in future editions.

### 1.2.1 Conventions

Data types are formatted like this: `int`, `Point`, `Path`. Plurals are formatted in the same way: `ints`, `Points`, `Paths`. It is poor typographical practice to typeset a single word using more than one font, e.g., `ints`, `Points`, `Paths`. This applies to data types whose plurals do not end in "s" as well, e.g., the plural of the C++ class `Polyhedron` is `Polyhedra`.

When C++ functions are discussed in this manual, I always include a pair of parentheses to make it clear that the item in question is a function and not a variable, but I generally do not include the arguments. For example, if I mention the function `foo()`, this doesn't imply that `foo()` takes no arguments. If it were appropriate, I would include the argument type:

```
foo(int)
```

or the argument type and a placeholder name:

```
foo(int arg)
```

or I would write

```
foo(void)
```

to indicate that `foo()` takes no arguments. Also, I generally don't indicate the return type, unless it is relevant. If it is a member function of a class, I may indicate this, e.g., `bar_class::foo()`, or not, depending on whether this information is relevant. This convention differs from that used in the [Function Index], page 291, which is generated automatically by Texinfo. There, only the name of the function appears, without parentheses, parameters, or return values. The class type of member functions may appear in the Function Index, (e.g., `bar_class::foo`), but only in index entries that have been entered explicitly by the author; such entries are not generated by Texinfo automatically.

Examples are formatted as follows:

```
Point p0(1, 2, 3);
Point p1(5, 6, 7.9);
Path pa(p0, p1);
p0.show("p0:");
└─ p0: (1, 2, 3)
```

Examples can contain the following symbols:

- └─ Indicates output to the terminal when 3DLDF is run.
- ⇒ Indicates a result of some sort. It may precede a illustration generated by the code in the example.
- error** Indicates that the following text is an error message.

This manual does not use all of the symbols provided by Texinfo. If you find a symbol you don't understand in this manual (which shouldn't happen), see page 103 of the Texinfo manual.

Symbols:

$\mathbb{N}$	The set of the natural numbers $\{0, 1, 2, 3, 4, \dots\}$ .
$\mathbb{Z}$	The set of the integers $\{\dots, -3, -2, -1, 0, 1, 2, 3, 4, \dots\}$ .
$\mathbb{R}$	The set of the real numbers.

## 1.2.2 Illustrations

The illustrations in this manual have been created using 3DLDF. The code that generates them is in the Texinfo files themselves, that contain the text of the manual. Texinfo is based on  $\text{\TeX}$ , so it's possible to make use of the latter's facility for writing ASCII text to files using  $\text{\TeX}$ 's `\write` command.

The file `'3DLDF-1.1.5.1/CWEB/exampman.web'` contains the C++ code, and the file `'3DLDF-1.1.5.1/CWEB/examples.mp'` contains the MetaPost code for generating the illustrations. 3DLDF was built using GCC 2.95 when the illustrations were generated. For some reason, GCC 3.3 has difficulty with them. It works to generate them in batches of about 50 with GCC 3.3.

MetaPost outputs Encapsulated PostScript files. These can be included in  $\text{\TeX}$  files, as explained below. However, in order to display the illustrations in the HTML version of this manual, I had to convert them to PNG ("Portable Network Graphics") format (<http://www.libpng.org/pub/png/index.html>). See Section 11.2.1 [Converting EPS Files], page 76, for instructions on how to do this.

Please note that the illustrations cannot be shown in the Info output format!

If you have problems including the illustrations in the printed version, for example, if your installation doesn't have `dvips`, look for the following lines in `'3DLDF.texi'`:

```
\doepsftrue    %% One of these two lines should be commented-out.
%\doepsffalse
```

Now, remove the `'%'` from in front of `'\doepsffalse'` and put one in front of `'\doepsftrue'`. This will prevent the illustrations from being included. This should only be done as a last resort, however, because it will make it difficult if not impossible to understand this manual.

The C++ code in an example is not always the complete code used to create the illustration that follows it, since the latter may be cluttered with commands that would detract from the clarity of the example. The actual code used always follows the example in the Texinfo source file, so the latter may be referred to, if the reader wishes to see exactly what code was used to generate the illustration.

You may want to skip the following paragraphs in this section, if you're reading this manual for the first time. Don't worry if you don't understand it, it's meaning should become clear after reading the manual and some experience with using 3DLDF.

The file `'3DLDF.texi'` in the directory `'3DLDF-1.1.5.1/DOC/TEXINFO'`, the driver file for this manual, contains the following  $\text{\TeX}$  code:



```

\newif\ifmakeexamples
\makeexamplestrue    %% One of these two lines should be commented-out.
%\makeexamplesfalse

```

When `texi2dvi` is run on `3DLDF.texi`, `\makeexamplestrue` is not commented-out, and `\makeexamplesfalse` is, the C++ code for the illustrations is written to the file `examples.web`. If the EPS files don't already exist (in the directory `3DLDF-1.1.5.1/DOC/TEXINFO/EPS`), the  $\TeX$  macro `\PEX`, which includes them in the Texinfo files, will signal an error each time it can't find one. Just type `'s'` at the command line to tell  $\TeX$  to keep going. If you want to be sure that these are indeed the only errors, you can type `<RETURN>` after each one instead.

`texi2dvi 3DLDF.texi` also generates the file `extext.tex`, which contains  $\TeX$  code for including the illustrations by themselves.

`examples.web` must now be moved to `3DLDF-1.1.5.1/CWEB/` and ctangled, `examples.c` must be compiled, and 3DLDF must be relinked. `ctangle examples` also generates the header file `example.h`, which is included in `main.web`. Therefore, if the contents of `example.h` have changed since the last time `main.web` was ctangled, `main.web` will have to be ctangled, and `main.c` recompiled, before `3dldf` is relinked.<sup>1</sup>

Running `3dldf` and MetaPost now generates the EPS (Encapsulated PostScript) files `3DLDFmp.1` through (currently) `3DLDFmp.199` for the illustrations. They must be moved to `3DLDF-1.1.5.1/DOC/TEXINFO/EPS`. Now, when `texi2dvi 3DLDF.texi` is run again, the `dvips` command `\epsffile` includes the EPS files for the illustrations in the manual. `3DLDF.texi` includes the line `\input epsf`, so that `\epsffile` works. Of course, `dvips` (or some other program that does the job) must be used to convert `3DLDF.dvi` to a PostScript file. To see exactly how this is done, take a look at the `.texi` source files of this manual.<sup>2</sup>

In the `3DLDF.texi` belonging to the 3DLDF distribution, `\makeexamplestrue` will be commented-out, and `makeexamplesfalse` won't be, because the EPS files for the illustrations are included in the distribution.

The version of `examples.web` in `3DLDF-1.1.5.1/CWEB` merely includes the files `subex1.web` and `subex2.web`. If you rename `3DLDF-1.1.5.1/CWEB/exampman.web` to `examples.web`, you can generate the illustrations.

## 1.3 CWEB Documentation

As mentioned above, 3DLDF has been programmed using CWEB, which is a “literate programming” tool developed by Donald E. Knuth and Silvio Levy. See Section 1.1 [Sources of Information], page 1, for a reference to the CWEB manual. Knuth's  *$\TeX$ —The Program and Metafont—The Program* both include a section “How to read a WEB” (pp. x–xv, in both volumes).

<sup>1</sup> `ctangle` creates `<filename>.c` from `<filename>.web`, so the compiler must compile the C++ files using the `-x c++` option. Otherwise, it would handle them as if they contained C code.

<sup>2</sup> If you want to try generating the illustrations yourself, you can save a little run-time by calling `tex 3DLDF.texi` the first time, rather than `texi2dvi`. The latter program runs  $\TeX$  twice, because it needs two passes in order to generate the contents, indexing, and cross reference information (and maybe some other things, too).

CWEB files combine source code and documentation. Running `ctangle` on a CWEB file, for example, `main.web`, produces the file `main.c` containing C or C++ code. Running `cweave main.web` creates a  $\TeX$  file with pretty-printed source code and nicely formatted documentation. I find that using CWEB makes it more natural to document my code as I write it, and makes the source files easier to read when editing them. It does have certain consequences with regard to compilation, but these are taken care of by `make`. See Chapter 39 [Adding a File], page 272, and Chapter 41 [Changes], page 277, for more information.

The CWEB files in the directory `'3DLDF-1.1.5.1/CWEB/'` contain the source code for 3DLDF. The file `'3DLDFprg.web'` in this directory is only ever used for cweaving; it is never ctangled and contains no C++ code for compilation. It does, however, include all of the other CWEB files, so that `cweave 3DLDFprg.web` generates the  $\TeX$  file containing the complete documentation of the source code of 3DLDF.

The files `'3DLDF-1.1.5.1/CWEB/3DLDFprg.tex'`, `'3DLDF-1.1.5.1/CWEB/3DLDFprg.dvi'`, and `'3DLDF-1.1.5.1/CWEB/3DLDFprg.ps'` are included in the distribution of 3DLDF as a convenience. However, users may generate them themselves, should there be some reason for doing so, by entering `make ps` from the command line of a shell from the working directory `'3DLDF-1.1.5.1/'` or `'3DLDF-1.1.5.1/CWEB'`. Alternatively, the user may generate them by hand from the working directory `'3DLDF-1.1.5.1/CWEB/'` in the following way:

1. `cweave 3DLDFprg.web` generates `'3DLDFprg.tex'`.
2. `tex 3DLDFprg` or `tex 3DLDFprg.tex` generates `'3DLDFprg.dvi'`.
3. `dvips -o 3DLDFprg.ps 3DLDFprg` (possibly with additional options) generates `'3DLDFprg.ps'`.
4. `lpr -P<print queue> 3DLDFprg.ps` sends `'3DLDFprg.ps'` to a printer, on a UNIX or UNIX-like system.

The individual commands may differ, depending on the system you're using.

## 1.4 Metafont and MetaPost

Metafont is a system created by Donald E. Knuth for generating fonts, in particular for use with  $\TeX$ , his well-known typesetting system.<sup>3</sup> Expressed in a somewhat simplified way, Metafont is a system for programming curves, which are then digitized and output in the form of run-time encoded bitmaps. (See Knuth's *The Metafontbook* for more information).

John D. Hobby modified Metafont's source code to create MetaPost, which functions in much the same way, but outputs encapsulated PostScript (EPS) files instead of bitmaps. MetaPost is very useful for creating graphics and is a convenient interface to PostScript. It is also easy both to imbed  $\TeX$  code in MetaPost programs, for instance, for typesetting labels, and to include MetaPost graphics in ordinary  $\TeX$  files, e.g., by using `dvips`.<sup>4</sup> Apart from simply printing the PostScript file output by `dvips`, there are many programs that

<sup>3</sup> Knuth, Donald E. *The  $\TeX$ book*. Computers and Typesetting; A. Addison-Wesley Publishing Company. Reading, Massachusetts 1986.

<sup>4</sup> Rokicki, Tomas. *Dvips: A DVI-to-PostScript Translator* February 1997. Available from CTAN. See Section 1.1 [Sources of Information], page 1.

can process ordinary or encapsulated PostScript files and convert them to other formats. Just two of the many possibilities are ImageMagick and GIMP, both of which can be used to create animations from MetaPost graphics.

However, MetaPost inherited a significant limitation from Metafont: it's not possible to use it for making three-dimensional graphics, except in a very limited way. One insuperable problem is the severe limitation on the magnitude of user-defined numerical variables in Metafont and MetaPost.<sup>5</sup> This made sense for Metafont's and MetaPost's original purposes, but they make it impossible to perform the calculations needed for 3D graphics.

Another problem is the data types defined in Metafont: Points are represented as pairs of real values and affine transformations as sets of 6 real values. This corresponds to the representation of points and affine transformations in the plane as a two-element vector on the one hand and a six element matrix on the other. While it is possible to work around the limitation imposed by having points be represented by only two values, it is impracticable in the case of the transformations.

For these reasons, I decided to write a program that would behave more or less like Metafont, but with suitable extensions, and the ability to handle three dimensional data; namely 3DLDF. It stores the data and performs the transformations and other necessary calculations and is not subject to the limitations of MetaPost and its data types. Upon output, it performs a perspective transformation, converting the 3D image into a 2D one. The latter can now be expressed as an ordinary MetaPost program, so 3DLDF writes its output as MetaPost code to a file.

In the following, it may be a little unclear why I sometimes refer to Metafont and sometimes to MetaPost. The reason is that Metafont inherited much of its functionality from Metafont. Certain operations in Metafont have no meaning in MetaPost and so have been removed, while MetaPost's function of interfacing with PostScript has caused other operations to be added. For example, in MetaPost, `color` is a data type, but not in Metafont. Unless otherwise stated, when I refer to Metafont, it can be assumed that what I say applies to MetaPost as well. However, when I refer to MetaPost, it will generally be in connection with features specific to MetaPost.

## 1.5 Caveats

### 1.5.1 Accuracy

When 3DLDF is run, it uses the three-dimensional data contained in the user code to create a two-dimensional projection. Currently, this can be a perspective projection, or a parallel projection onto one of the major planes. MetaPost code representing this projection is then written to the output file. 3DLDF does no *scan conversion*,<sup>6</sup> so all of the curves in the

---

<sup>5</sup> “[...] METAFONT deals only with numbers in a limited range: A numeric token must be less than 4096, and its value is always rounded to the nearest multiple of  $\frac{1}{65536}$ .” Knuth, *The METAFONTbook*, p. 50.

<sup>6</sup> *Scan conversion* is the process of digitizing geometric data. The ultimate result is a  $2 \times 2$  map of pixels, which can be used for printing or representing the projection on a computer screen. The number of pixels per a given unit of measurement is the *resolution* of a given output device, e.g., 300 pixels per inch.

projection are generated by means of the algorithms MetaPost inherited from Metafont. These algorithms, however, are designed to find the “most pleasing curve”<sup>7</sup> given one or more two-dimensional points and connectors; they do not account for the fact that the two-dimensional points are projections of three-dimensional ones. This can lead to unsatisfactory results, especially where extreme foreshortening occurs. In particular, ‘curl’, ‘dir’, ‘tension’, and control points should be used cautiously, or avoided altogether, when specifying connectors.

3DLDF operates on the assumption that, given an adequate number of points, MetaPost will produce an adequate approximation to the desired curve *in perspective*, since the greater the number of points given for a curve, the less “choice” MetaPost has for the path through them. My experience with 3DLDF bears this out. Generally, the curves look quite good. Where problems arise, it usually helps to increase the number of points in a curve.

A more serious problem is the imprecision resulting from the operation of rotation. Rotations use the trigonometric functions, which return approximate values. This has the result that points that should have identical coordinate values, sometimes do not. This has consequences for the functions that compare points. The more rotations are applied to points, the greater the divergence between their actual coordinate values, and the values they should have. So far, I haven’t found a solution for this problem. On the other hand, it hasn’t yet affected the usability of 3DLDF.

## 1.5.2 No Input Routine

3DLDF does not yet include a routine for reading input files. This means that user code must be written in C++, compiled, and linked with the rest of the program. I admit, this is not ideal, and writing an input routine for user code is one of the next things I plan to add to 3DLDF.

I plan to use Flex and Bison to write the input routine.<sup>8</sup> The syntax of the input code should be as close as possible to that of MetaPost, while taking account of the differences between MetaPost and 3DLDF.

For the present, however, the use of 3DLDF is limited to those who feel comfortable using C++ and compiling and relinking programs. Please don’t be put off by this! It’s not so difficult, and `make` does most of the work of recompiling and running 3DLDF. See Chapter 11 [Installing and Running 3DLDF], page 73, for more information.

## 1.6 Ports

I originally developed 3DLDF on a DECalpha Personal Workstation with two processors running under the operating system Tru64 Unix 5.1, using the DEC C++ compiler. I then ported it to a PC Pentium 4 running under Linux 2.4, using the GNU C++ compiler GCC 2.95.3, and a PC Pentium II XEON under Linux 2.4, using GCC 3.3. I am currently only maintaining the last version. I do not believe that it’s worthwhile to maintain a version for GCC 2.95. While I would like 3DLDF to run on as many platforms as possible, I would

---

<sup>7</sup> Knuth, *The METAFONTbook*, Chapter 14, p. 127.

<sup>8</sup> Flex is a program for generating text scanners and Bison is a parser generator. They are available from <http://www.gnu.org>.

rather spend my time developing it than porting it. This is something where I would be grateful for help from other programmers.

Although I am no longer supporting ports to other systems, I have left some conditionally compiled code for managing platform dependencies in the CWEB sources of 3DLDF. This may make it easier for other people who want to port 3DLDF to other platforms.

Currently, the files `io.web`, `loader.web`, `main.web`, `points.web`, and `pspg1b.web` contain conditionally compiled code, depending on which compiler, or in the case of GCC, which version of the compiler, is used. The DEC C++ compiler defines the preprocessor macro `__DECCXX` and GCC defines `__GNUC__`. In order to distinguish between GCC 2.95.3 and GCC 3.3, I've added the macros `LDF_GCC_2_95` and `LDF_GCC_3_3` in `loader.web`, which should be defined or undefined, depending on which compiler you're using. In the distribution, `LDF_GCC_3_3` is defined and `LDF_GCC_2_95` is undefined, so if you want to try using GCC 2.95, you'll have to change this (it's not guaranteed to work).

3DLDF 1.1.5.1 now uses Autoconf and Automake, and the `configure` script generates a `config.h` file, which is now included in `loader.web`. Some of the preprocessor macros defined in `config.h` are used to conditionally include library header files, but so far, there is no error handling code for the case that a file can't be included. I hope to improve the way 3DLDF works together with Autoconf and Automake in the near future.

3DLDF 1.1.5 is the first release that contains template functions. Template instantiation differs from compiler to compiler, so using template functions will tend to make 3DLDF less portable. See Section 11.1.1 [Template Functions], page 73, for more information. I am no longer able to build 3DLDF on the DECalpha Personal Workstation. I'm fairly sure that it would be possible to port it, but I don't plan to do this, since Tru64 Unix 5.1 and the DEC C++ compiler are non-free software.

## 1.7 Contributing to 3DLDF

So far, I've been the sole author and user of 3DLDF. I would be very interested in having other programmers contribute to it. I would be particularly interested in help in making 3DLDF conform as closely as possible to the GNU Coding Standards. I would be grateful if someone would write proper Automake and Autoconf files, since I haven't yet learned how to do so (I'm working on it).

See Chapter 1 [Introduction], page 1, for information on how to contact the author.

## Using 3DLDF

Since 3DLDF does not yet have an input routine, user code must be written in C++ (in `main.web`, or some other file) and compiled. Then, 3DLDF must be relinked, together with the new file of object code resulting from the compilation. For now, the important point is that the text of the examples in this manual represent C++ code. See Chapter 11 [Installing and Running 3DLDF], page 73, for more information.

## 2 Points

### 2.1 Declaring and Initializing Points

The most basic drawable object in 3DLDF is `class Point`. It is analogous to `pair` in Metafont. For example, in Metafont one can define a `pair` using the “z” syntax as follows:

```
z0 = (1cm, 1cm);
```

There are other ways of defining `pairs` in Metafont (and MetaPost), but this is the usual way.

In 3DLDF, a `Point` is declared and initialized as follows:

```
Point pt0(1, 2, 3);
```

This simple example demonstrates several differences between Metafont and 3DLDF. First of all, there is no analog in 3DLDF to Metafont’s “z” syntax. If I want to have `Points` called “`pt0`”, “`pt1`”, “`pt2`”, etc., then I must declare each of them to be a `Point`:

```
Point pt0(10, 15, 2);
Point pt1(13, 41, 5.5);
Point pt2(62.9, 7.02, 8);
```

Alternatively, I could declare an array of `Points`:

```
Point pt[3];
```

Now I can refer to `pt[0]`, `pt[1]`, and `pt[2]`.

In the Metafont example, the x and y-coordinates of the `pair z0` are specified using the unit of measurement, in this case, centimeters. This is currently not possible in 3DLDF. The current unit of measurement is stored in the static variable `Point::measurement_units`, which is a `string`. Its default value is “cm” for “centimeters”. At present, it is best to stick with one unit of measurement for a drawing. After I’ve defined an input routine, 3DLDF should handle units of measurement in the same way that Metafont does.

Another difference is that the `Points pt0`, `pt1`, and `pt2` have three coordinates, x, y, and z, whereas `z0` has only two, x and y. Actually, the difference goes deeper than this. In Metafont, a `pair` has two parts, `xpart` and `ypart`, which can be examined by the user. In 3DLDF, a `Point` contains the following sets of coordinates:

```
world_coordinates
user_coordinates
view_coordinates
projective_coordinates
```

These are sets of 3-dimensional *homogeneous* coordinates, which means that they contain four coordinates: x, y, z, and w. Homogeneous coordinates are used in the affine and perspective transformations (see Chapter 4 [Transforms], page 18).

Currently, only `world_coordinates` and `projective_coordinates` are used in 3DLDF. The `world_coordinates` refer to the position of a `Point` in 3DLDF’s basic, unchanging coordinate system. The `projective_coordinates` are the coordinates of the two-dimensional projection of the `Point` onto a plane. This projection is what is ultimately printed out or displayed on the computer screen. Please note, that when the coordinates of a `Point` are referred to in this manual, the `world_coordinates` are meant, unless otherwise stated.

`Points` can be declared and their values can be set in different ways.

```
Point pt0;
Point pt1(1);
Point pt2(2.3, 52);
Point pt3(4.5, 7, 13.205);
```

`pt0` is declared without any arguments, i.e., using the default constructor, so the values of its `x`, `y`, and `z`-coordinates are all 0.

`pt1` is declared and initialized with one argument for the `x`-coordinate, so its `y` and `z`-coordinates are initialized with the values of `CURR_Y` and `CURR_Z` respectively. The latter are static constant data members of class `Point`, whose values are 0 by default. They can be reset by the user, who should make sure that they have sensible values.

`pt2` is declared and initialized with two arguments for its `x` and `y`-coordinates, so its `z`-coordinate is initialized to the value of `CURR_Z`. Finally, `pt3` has an argument for each of its coordinates.

Please note that `pt0` is constructed using a the default constructor, whereas the other `Points` are constructed using a constructor with one required argument (for the `x`-coordinate), and two optional arguments (for the `y` and `z`-coordinates). The default constructor always sets all the coordinates to 0, irrespective of the values of `CURR_Y` and `CURR_Z`.

## 2.2 Setting and Assigning to Points

It is possible to change the value of the coordinates of `Points` by using the *assignment operator* `=` (`Point::operator=()`) or the function `Point::set()` (with appropriate arguments):

```
Point pt0(2, 3.3, 7);
Point pt1;
pt1 = pt0;
pt0.set(34, 99, 107.5);
pt0.show("pt0:");
  ─ pt0: (34, 99, 107.5)
pt1.show("pt1:");
  ─ pt1: (2, 3.3, 7)
```

In this example, `pt0` is initialized with the coordinates (2, 3.3, 7), and `pt1` with the coordinates (0, 0, 0). `pt1 = pt0` causes `pt1` to have the same coordinates as `pt0`, then the coordinates of `pt0` are changed to (34, 99, 107.5). This doesn't affect `pt1`, whose coordinates remain (2, 3.3, 7).

Another way of declaring and initializing `Points` is by using the *copy constructor*:

```
Point pt0(1, 3.5, 19);
Point pt1(pt0);
Point pt2 = pt0;
Point pt3;
pt3 = pt0;
```

In this example, `pt1` and `pt2` are both declared and initialized using the copy constructor; `Point pt2 = pt0` does not invoke the assignment operator. `pt3`, on the other hand, is declared using the default constructor, and not initialized. In the following line, `pt3 = pt0` does invoke the assignment operator, thus resetting the coordinate values of `pt3` to those of `pt0`.



## 3 Transforming Points

Points don't always have to remain in the same place. There are various ways of moving or *transforming* them:

- Shifting. This is often called “translating”, but the operation in Metafont that performs translation is called `shift`, so I call it “shifting”.
- Scaling.
- Shearing.
- Rotating about an axis.

`class Point` has several member functions for applying these *affine transformations*<sup>1</sup> to a `Point`. Most of the arguments to these functions are of type `real`. As you may know, there is no such data type in C++. I have defined `real` using `typedef` to be either `float` or `double`, depending on the value of a preprocessor switch for conditional compilation.<sup>2</sup> 3DLDF uses many `real` values and I wanted to be able to change the precision used by making one change (in the file ‘`pspg1b.web`’) rather than having to examine all the places in the program where `float` or `double` are used. Unfortunately, setting `real` to `double` currently doesn't work.

### 3.1 Shifting

The function `shift()` adds its arguments to the corresponding `world_coordinates` of a `Point`. In the following example, the function `show()` is used to print the `world_coordinates` of `p0` to standard output.

```
Point p0(0, 0, 0);
p0.shift(1, 2, 3);
p0.show("p0:");
  † p0: (1, 2, 3)
p0.shift(10);
p0.show("p0:");
  † p0: (11, 2, 3)
p0.shift(0, 20);
p0.show("p0:");
  † p0: (11, 22, 3)
p0.shift(0, 0, 30);
p0.show("p0:");
  † p0: (11, 22, 33)
```

---

<sup>1</sup> *Affine transformations* are operations that have the property that parallelity of lines is maintained. That is, if two lines (each determined by two points) are parallel before the transformation, they will also be parallel after the transformation. Affine transformations are discussed in many books about computer graphics and geometry. For 3DLDF, I've mostly used Jones, *Computer Graphics through Key Mathematics* and Salomon, *Computer Graphics and Geometric Modeling*.

<sup>2</sup> I try to avoid the use of preprocessor macros as much as possible, for the reasons given by Stroustrup in the *The C++ Programming Language*, §7.8, pp. 160–163, and *Design and Evolution of C++*, Chapter 18, pp. 423–426. However, conditional compilation is one of the tasks that only the preprocessor can perform.

`shift` takes three `real` arguments, whereby the second and third are optional. To shift a `Point` in the direction of the positive or negative y-axis, and/or the positive or negative z-axis only, then a 0 argument for the x direction, and possibly one for the y direction must be used as placeholders, as in the example above.

`shift()` can be invoked with a `Point` argument instead of `real` arguments. In this case, the x, y, and z-coordinates of the argument are used for shifting the `Point`:

```
Point a(10, 10, 10);
Point b(1, 2, 3);
a.shift(b);
a.show("a:")
└─ a: (11, 12, 13)
```

Another way of shifting `Points` is to use the binary `+=` operator (`Point::operator+=()`) with a `Point` argument.

```
Point a0(1, 1, 1);
Point a1(2, 2, 2);
a0 += a1;
a0.show("a0:");
└─ a0: (3, 3, 3)
```

## 3.2 Scaling

The function `scale()` takes three `real` arguments. The x, y, and z-coordinates of the `Point` are multiplied by the first, second, and third arguments respectively. Only the first argument is required; the default for the others is 1.

If one wants to perform scaling in either the y-dimension only, or the y and z-dimensions only, a dummy argument of 1 must be passed for scaling in the x-dimension. Similarly, if one wants to perform scaling in the z-dimension only, dummy arguments of 1 must be passed for scaling in the x and y-dimensions.

```
Point p0(1, 2, 3);
p0.scale(2, 3, 4);
p0.show("p0:");
└─ p0: (2, 6, 12)
p0.scale(2);
p0.show("p0:");
└─ p0: (4, 6, 12)
p0.scale(1, 3);
p0.show("p0:");
└─ p0: (4, 18, 12)
p0.scale(1, 1, 3);
p0.show("p0:");
└─ p0: (4, 18, 36)
```

### 3.3 Shearing

Shearing is more complicated than shifting or scaling. The function `shear()` takes six `real` arguments. If  $p$  is a `Point`, then `p.shear(a, b, c, d, e, f)` sets  $x_p$  to  $x_p + ay_p + bz_p$ ,  $y_p$  to  $y_p + cx_p + dz_p$ , and  $z_p$  to  $z_p + ex_p + fy_p$ . In this way, each coordinate of a `Point` is modified based on the values of the other two coordinates, whereby the influence of the other coordinates on the new value is weighted according to the arguments.

```
Point p(1, 1, 1);
p.shear(1);
p.show("p:");
  └ p: (2, 1, 1)
p.set(1, 1, 1);
p.shear(1, 1);
p.show("p:");
  └ p: (3, 1, 1)
p.set(1, 1, 1);
p.shear(1, 1, 2, 2, 3, 3);
p.show("p:");
  └ p: (3, 5, 7)
```

Fig. 1 demonstrates the effect of shearing the points of a rectangle in the x-y plane.

```
Point P0;
Point P1(3);
Point P2(3, 3);
Point P3(0, 3);
Rectangle r(p0, p1, p2, p3);
r.draw();
Rectangle q(r);
q.shear(1.5);
q.draw(black, "evenly");
```

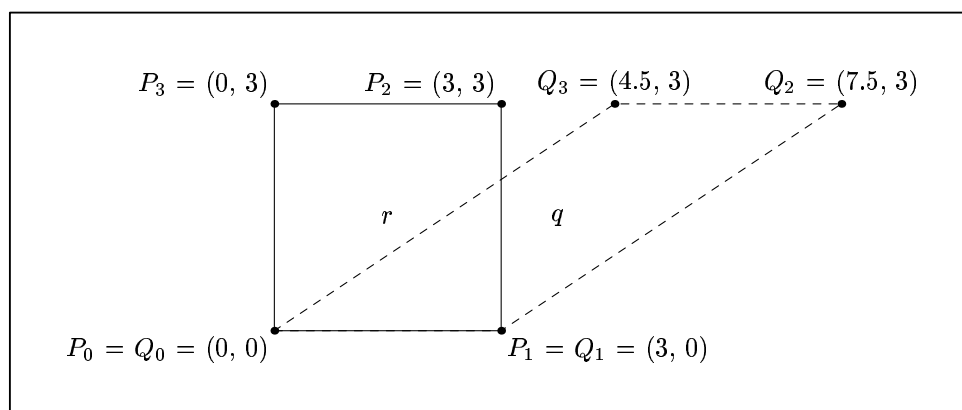

Figure 1.

### 3.4 Rotating

The function `rotate()` rotates a `Point` about one or more of the main axes. It takes three `real` arguments, specifying the angles of rotation in degrees about the x, y, and z-axes respectively. Only the first argument is required, the other two are 0 by default. If rotation about the y-axis, or the y and z-axes only are required, then 0 must be used as a placeholder for the first and possibly the second argument.

```
Point p(0, 1);
p.rotate(90);
p.show("p:");
  † p: (0, 0, -1)
p.rotate(0, 90);
p.show("p:");
  † p: (1, 0, 0)
p.rotate(0, 0, 90);
p.show("p:");
  † p: (0, 1, 0)
```

The rotations are performed successively about the x, y, and z-axes. However, rotation is not a commutative operation, so if rotation about the main axes in a different order is required, then `rotate()` must be invoked more than once:

```
Point A(2, 3, 4);
Point B(A);
A.rotate(30, 60, 90);
A.show("A:");
  † A: (-4.59808, -0.700962, 2.7141)
B.rotate(0, 0, 90);
B.rotate(0, 60);
B.rotate(30);
B.show("B:");
  † B: (-4.9641, 1.43301, -1.51795)
```

Rotation need not be about the main axes; it can also be performed about a line defined by two `Points`. The function `rotate()` with two `Point` arguments and a `real` argument for the angle of rotation (in degrees) about the axis. The `real` argument is optional, with  $180^\circ$  as the default.

```
Point p0 (-1.06066, 0, 1.06066);
Point p1 (1.06066, 0, -1.06066);
p1 *= p0.rotate(0, 30, 30);
p0.show("p0:");
  † p0: (-1.25477, -0.724444, 0.388228)
p1.show("p1:");
  † p1: (1.25477, 0.724444, -0.388228)
p0.draw(p1);
Point p2(1.06066, 0, 1.06066);
p2.show("p2:");
  † p2: (1.06066, 0, 1.06066)
```

```

Point p3(p2);
p3.rotate(p1, p0, 45);
p3.show("p3:");
└ p3 (1.09721, 1.15036, 1.17879)
Point p4(p2);
p4.rotate(p1, p0, 90);
p4.show("p4:");
└ p4: (0.882625, 2.05122, 0.485242)
Point p5(p2);
p5.rotate(p1, p0, 135);
p5.show("p5:");
└ p5: (0.542606, 2.17488, -0.613716)
Point p6(p2);
p6.rotate(p1, p0);
p6.show("p6:");
└ p6: (0.276332, 1.44889, -1.47433)

```

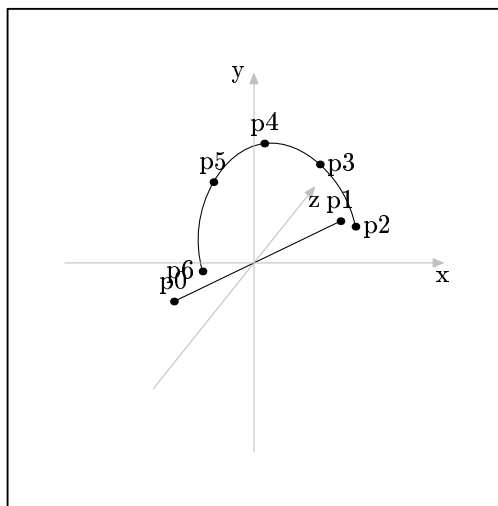

Figure 2.

I have sometimes gotten erroneous results using `rotate()` for rotation about two `Points`. It's usually worked to reverse the order of the `Point` arguments, or to change sign of the angle argument. I think I've fixed the problem, though.

## 4 Transforms

When `Points` are transformed using `shift()`, `shear()`, or one of the other transformation functions, the `world_coordinates` are not modified directly. Instead, another data member of `class Point` is used to store the information about the transformation, namely `transform` of type `class Transform`. A `Transform` object has a single data element of type `Matrix` and a number of member functions. A `Matrix` is simply a  $4 \times 4$  array<sup>1</sup> of `reals` defined using `typedef real Matrix[4][4]`. Such a matrix suffices for performing all of the transformations (affine and perspective) possible in three-dimensional space.<sup>2</sup> Any combination of transformations can be represented by a single transformation matrix. This means that consecutive transformations of a `Point` can be “saved up” and applied to its coordinates all at once when needed, rather than updating them for each transformation.

`Transforms` work by performing matrix multiplication of `Matrix` with the homogeneous `world_coordinates` of `Points`. If a set of homogeneous coordinates  $\alpha = (x, y, z, w)$  and

$$\text{Matrix } M = \begin{pmatrix} a & e & i & m \\ b & f & j & n \\ c & g & k & o \\ d & h & l & p \end{pmatrix}$$

then the set of homogeneous coordinates  $\beta$  resulting from multiplying  $\alpha$  and  $M$  is calculated as follows:

$$\beta = \alpha \times M = ((xa+yb+zc+wd), (xe+yf+zg+wh), (xi+yj+zk+wl), (xm+yn+zo+wp))$$

Please note that each coordinate of  $\beta$  can be influenced by all of the coordinates of  $\alpha$ .

Operations on matrices are very important in computer graphics applications and are described in many books about computer graphics and geometry. For 3DLDF, I’ve mostly used Huw Jones’ *Computer Graphics through Key Mathematics* and David Salomon’s *Computer Graphics and Geometric Modeling*.

It is often useful to declare and use `Transform` objects in 3DLDF, just as it is for `transforms` in Metafont. Transformations can be stored in `Transforms` and then be used to transform `Points` by means of `Point::operator*=(const Transform&)`.

1. `Transform t;`
2. `t.shift(0, 1);`
3. `Point p(1, 0, 0);`
4. `p *= t;`

<sup>1</sup> It is unfortunate that the terms “array”, “matrix”, and “vector” have different meanings in C++ and in normal mathematical usage. However, in practice, these discrepancies turn out not to cause many problems. Stroustrup, *The C++ Programming Language*, § 22.4, p. 662.

<sup>2</sup> In fact, none of the operations for transformations require all of the elements of a  $4 \times 4$  matrix. In many 3D graphics programs, the matrix operations are modified to use smaller transformation matrices, which reduces the storage requirements of the program. This is a bit tricky, because the affine transformations and the perspective transformation use different elements of the matrix. I consider that the risk of something going wrong, possibly producing hard-to-find bugs, outweighs any benefits from saving memory (which is usually no longer at a premium, anyway). In addition, there may be some interesting non-affine transformations that would be worth implementing. Therefore, I’ve decided to use full  $4 \times 4$  matrices in 3DLDF.

```
5. p.show("p:");
   └ p: (1, 1, 0)
```

When a `Transform` is declared (line 1), it is initialized to an *identity matrix*. All identity matrices are square, all of the elements of the main diagonal (upper left to lower right) are 1, and all of the other elements are 0. So a  $4 \times 4$  identity matrix, as used in 3DLDF, looks like this:

$$\begin{pmatrix} 1 & 0 & 0 & 0 \\ 0 & 1 & 0 & 0 \\ 0 & 0 & 1 & 0 \\ 0 & 0 & 0 & 1 \end{pmatrix}$$

If a matrix  $A$  is multiplied with an identity matrix  $I$ , the result is identical to  $A$ , i.e.,  $A \times I = A$ . This is the salient property of an identity matrix.

The same affine transformations are applied in the same way to `Transforms` as they are to `Points`, i.e., the functions `scale()`, `shift()`, `shear()`, and `rotate()` correspond to the `Point` versions of these functions, and they take the same arguments:

```
Point p;
Transform t;
p.shift(3, 4, 5);
t.shift(3, 4, 5);
⇒ p.transform ≡ t
p.show_transform("p:");
└ p:
  Transform:
      0  0.707  0.707  0
    -0.866  0.354 -0.354  0
      -0.5 -0.612  0.612  0
      0  0  0  1
t.show("t:");
└ t:
      0  0.707  0.707  0
    -0.866  0.354 -0.354  0
      -0.5 -0.612  0.612  0
      0  0  0  1
```

## 4.1 Applying Transforms to Points

A `Transform`  $t$  is applied to a `Point`  $P$  using the binary `*=` operation (`Point::operator*=(const Transform&)`) which performs matrix multiplication of `P.transform` by `t`. See Section 22.6 [Point Reference; Operators], page 123.

```
Point P(0, 1);
Transform t;
t.rotate(90);
t.show("t:");
└ t:
```

```

    1      0      0      0
    0      0     -1      0
    0      1      0      0
    0      0      0      1
P *= t;
P.show_transform("P:");
└ P:
Transform:
    1      0      0      0
    0      0     -1      0
    0      1      0      0
    0      0      0      1
P.show("P:");
└ P: (0, 0, -1)

```

In the example above, there is no real need to use a `Transform`, since `P.rotate(90)` could have been called directly. As constructions become more complex, the power of `Transforms` becomes clear:

```

1. Point p0(0, 0, 0);
2. Point p1(10, 5, 10);
3. Point p2(16, 14, 32);
4. Point p3(25, 50, 99);
5. Point p4(12, 6, 88);
6. Transform a;
7. a.shift(2, 3, 4);
8. a.scale(1, 3, 1);
9. p2 *= p3 *= a;
10. a.rotate(p0, p1, 75);
11. p4 *= a;
12. p2.show("p2:");
    └ p2: (18, 51, 36)
13. p3.show("p3:");
    └ p3: (27, 159, 103)
14. p4.show("p4:");
    └ p4: (24.4647, -46.2869, 81.5353)

```

In this example,  $a$  is shifted and scaled, and  $a$  is applied to both in line 9. This works, because the binary operation `operator*(const Transform& t)` returns  $t$ , making it possible to chain invocations of `*`. Following this,  $a$  is rotated  $75^\circ$  about the line through  $p_0$  and  $p_1$ . Finally, all three transformations, which are stored in  $a$ , are applied to  $p_4$ .

## 4.2 Inverting Transforms

*Inversion* is another operation that can be performed on `Transforms`. This makes it possible to reverse the effect of a `Transform`, which may represent multiple transformations.



```

Point p;
Transform t;
t.shift(1, 2, 3);
t.scale(2, 3, 4);
t.rotate(45, 45, 30);
t.show("t:");
┌ t:
  1.22   0.707   1.41   0
  0.238   2.59  -1.5   0
 -3.15   1.45    2     0
 -7.74  10.2   4.41   1
p *= t;
p.show("p:");
┌ p: (-7.74, 10.2, 4.41)
Transform u;
u = t.inverse();
u.show("u:");
┌ u:
  0.306  0.0265  -0.197  2.85e-09
  0.177  0.287   0.0906  -1.12e-09
  0.354  -0.167   0.125    0
    -1    -2     -3     1
p *= u;
p.show("p:");
┌ p: (0, 0, 0)
u *= t;
u.show("u:");
┌ u:
  1     0     0     0
  0     1     0     0
  0     0     1     0
  0     0     0     1

```

If `inverse()` is called with no argument, or with the argument `false`, it returns a `Transform` representing its inverse, and remains unchanged. If it is called with the argument `true`, it is set to its inverse.

Complete reversal of the transformations applied to a `Point`, as in the previous example, probably won't make much sense. However, partial reversal is a valuable technique. For example, it is used in `rotate()` for rotation about a line defined by two `Points`. The following example merely demonstrates the basic principle; an example that does something useful would be too complicated.

```
Transform t;
t.shift(3, 4, 5);
t.rotate(45);
t.scale(2, 2, 2);
Point p;
p *= t;
p.show("p:");
  † p: (6, 12.7279, 1.41421)
t.inverse(true);
p.rotate(90, 90);
p *= t;
p.show("p:");
  † p: (3.36396, -5.62132, -2.37868)
```

## 5 Drawing and Labeling Points

### 5.1 Drawing Points

It's all very well to declare `Points`, place them at particular locations, print their locations to standard output, and transform them, but none of these operations produce any MetaPost output. In order to do this, the first step is to use *drawing and filling commands*. The drawing and filling commands in 3DLDF are modelled on those in Metafont.

The following example demonstrates how to draw a dot specifying a `Color` (see Chapter 16 [Color Reference], page 87) and a `pen`<sup>1</sup>.

```
Point P(0, 1);
P.drawdot(Colors::black, "pencircle scaled 3mm");
```

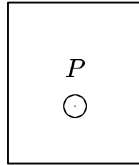

Figure 3.

In `drawdot()`, a `Color` argument precedes the `string` argument for the pen, so “`Colors::black`” must be specified as a placeholder in the call to `drawdot()`.<sup>2</sup>

The following example “undraws” a dot at the same location using a smaller pen. `undrawdot()` does not take a `Color` argument.

```
p.undrawdot("pencircle scaled 2mm");
```

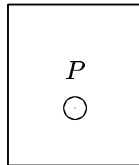

Figure 4.

For complete descriptions of `drawdot()` and `undrawdot()`, see Section 22.18 [Point Reference; Drawing], page 143.

Drawing and undrawing dots is not very exciting. In order to make a proper drawing it is necessary to *connect* the `Points`. The most basic way of doing this is to use the `Point` member function `draw()` with a `Point` argument:

```
Point p0;
Point p1(2, 2);
p0.draw(p1);
```

<sup>1</sup> Pens are a concept from Metafont. In 3DLDF, there is currently no type “`Pen`”. Pen arguments to functions are simply `strings`, and are written unaltered to `out_stream`. For more information about Metafont's pens, see Knuth, *The Metafontbook*, Chapter 4.

<sup>2</sup> `Colors` are declared in the namespace `Colors`, so if you have a “`using`” declaration in the function where you use `drawdot()`, you can write “`black`” instead of “`Colors::black`”. For more information about namespaces, see Stroustrup, *The C++ Programming Language*, Chapter 8.

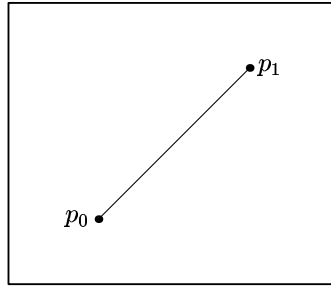

Figure 5.

`p0.draw(p1)` is equivalent in its effect to `p1.draw(p0)`.

The function `Point::draw()` takes a required `Point&` argument (a *reference*<sup>3</sup> to a `Point`) an optional `Color` argument, and optional `string` arguments for the dash pattern and the pen. The `string` arguments, if present, are passed unchanged to the output file. The empty `string` following the argument `p1` is a placeholder for the dash pattern argument, which isn't used here.

```
p0.draw(p1, Colors::gray, "", "pensquare scaled .5cm rotated 45");
```

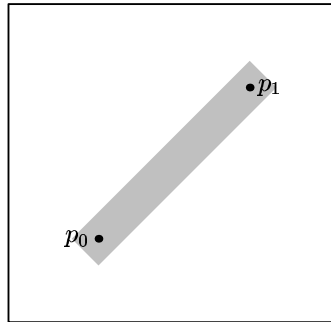

Figure 6.

The function `Point::undraw()` takes a required `Point&` argument and optional `string` arguments for the dash pattern and the pen. Unlike `Point::draw()`, a `Color` argument would have no meaning for `Point::undraw()`. The `string` arguments are passed unchanged to the output file.

`undraw()` can be used to “hollow out” the region drawn in Fig. 6. Since a dash pattern is used, portions of the middle of the region are not undrawn.

```
p0.undraw(p1, "evenly scaled 6", "pencircle scaled .2cm");
```

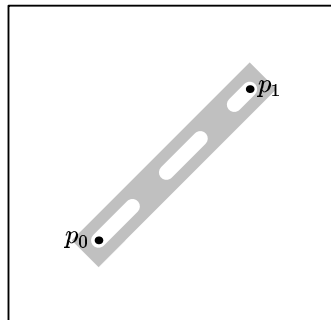

Figure 7.

---

<sup>3</sup> “A *reference* is an alternative name for an object. The main use of references is for specifying arguments and return values for functions in general and for overloaded operators (Chapter 11) in particular.” Stroustrup, *The C++ Programming Language*, §5.5, p. 97.

For complete descriptions of `draw()` and `undraw()`, see Section 22.18 [Point Reference; Drawing], page 143.

## 5.2 Labeling Points

The labels in the previous examples were made by using the functions `Point::label()` and `Point::dotlabel()`, which make it possible to include  $\TeX$  text in a drawing.

`label()` and `dotlabel()` take `string` arguments for the text of the label and the position of the label with respect to the `Point`. The label text is formatted using  $\TeX$ , so it can contain math mode material between dollar signs. Please note that double backslashes must be used, where a single backslash would suffice in a file of MetaPost code, for example, for  $\TeX$  control sequences. Alternatively, a `short` argument can be used for the label.

The position argument is optional, with "top" as the default. If the empty `string` "" is used, the label will be centered about the `Point` itself. This will usually only make sense for `label()`, because it would otherwise interfere with the dot. Valid arguments for the position are the same as in MetaPost: "top", "bot" (bottom), "lft" (left), "rt" (right), "ulft" (upper left), "urt" (upper right), "llft" (lower left), and "lrt" (lower right).

```

Point p0;
Point p1(1);
Point p2(2);
Point p3(p0);
Point p4(p1);
Point p5(p2);
p3 *= p4 *= p5.shift(0, 1);
p0.draw(p1);
p1.draw(p2);
p2.draw(p5);
p5.draw(p4);
p4.draw(p3);
p3.draw(p0);
p0.label("$p_0$", "");
p1.dotlabel(1);
p2.dotlabel("p2", "bot");
p3.dotlabel("This is $p_3$", "lft");
p4.label(4);
p5.label("$\\leftarrow p_5$", "rt");

```

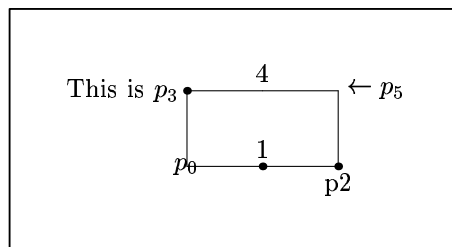

Figure 8.

For complete descriptions of `Point::label()` and `Point::dotlabel()`, see Section 22.19 [Points; Labelling], page 146.

## 6 Paths

**Points** alone are not enough for making useful drawings. The next step is to combine them into **Paths**, which are similar to Metafont's **paths**, except that they are three-dimensional. A **Path** consists of a number of **Points** and **strings** representing the *connectors*. The latter are not processed by 3DLDF, but are passed unchanged to the output file. They must be valid connectors for MetaPost, e.g.:

```

..
...
--
---
&
curl{2}..
{dir 60}..
{z1 - z2}..
.. tension 1 and 1.5..
..controls z1 and z2..

```

Usually, it will only make sense to use `..` or `--`, and not `...`, `---`, `tension`, `curl`, `controls`, or any of the other possibilities, in **Paths**, unless you are sure that they will only be viewed with no foreshortening due to the perspective projection. This can be the case, when a **Path** lies in a plane parallel to one of the major planes, and is projected using parallel projection onto that plane. Otherwise, the result of using these connectors is likely to be unsatisfactory, because MetaPost performs its calculations based purely on the two-dimensional values of the points in the perspective projection. While the **Points** on the **Path** will be projected correctly, the course of the **Path** between these **Points** is likely to differ, depending on the values of the **Focus** used (see Section 9.2 [Focuses], page 62), so that different views of the same **Path** may well be mutually inconsistent. This problem doesn't arise with `--`, since the perspective projection does not "unstraighten" straight lines, but it does with `..`, even without `tension`, `curl`, or `controls`. The solution is to use enough **Points**, since a greater number of **Points** on a **Path** tends to reduce the number of possible courses through the **Points**.<sup>1</sup>

### 6.1 Declaring and Initializing Paths

There are various ways of declaring and initializing **Paths**. The simplest is to use the constructor taking two **Point** arguments:

```

Point A;
Point B(2, 2);
Path p(A, B);
p.draw();

```

---

<sup>1</sup> I believe that counter-examples could probably be constructed, but for the most common cases, the principle applies.

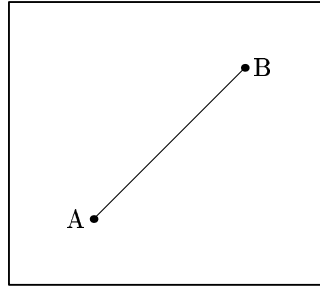

Figure 9.

`Paths` created in this way are important, because they are guaranteed to be linear, as long as no operations are performed on them that cause them to become non-linear. Linear `Paths` can be used to find *intersections*. See Section 26.17 [Path Intersections], page 197.

`Paths` can be declared and initialized using a single connector and an arbitrary number of `Points`. The first argument is a `string` specifying the connector. It is followed by a `bool`, indicating whether the `Path` is cyclical or not. Then, an arbitrary number of pointers to `Point` follow. The last argument must be 0.<sup>2</sup>

```
Point p[3];
p[0].shift(1);
p[1].set(1, 2, 2);
p[2].set(1, 0, 2);
Path pa("--", true, &p[0], &p[1], &p[2], 0);
pa.draw();
```

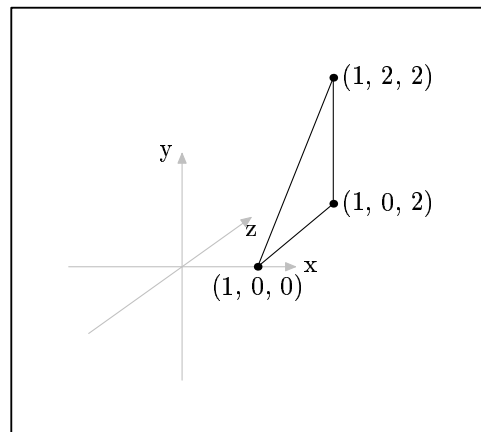

Figure 10.

Another constructor must be used for `Paths` with more than one connector and an arbitrary number of `Points`. The argument list starts with a pointer to `Point`, followed by `string` for the first connector. Then, pointer to `Point` arguments alternate with `string` arguments for the connectors. Again, the list of arguments ends in 0. There is no need for a `bool` to indicate whether the `Path` is cyclical or not; if it is, the last non-zero argument will be a connector, otherwise, it will be a pointer to `Point`.

```
Point p[8];
```

---

<sup>2</sup> It's easy to forget to use `Point*` arguments, rather than plain `Point` arguments, and to forget to end the list of arguments with 0. If plain `Point` arguments are used, compilation fails with GCC. With the DEC compiler, compilation succeeds, but a memory fault error occurs at run-time. If the argument list doesn't end in 0, neither compiler signals an error, but a memory fault error always occurs at run-time.



```

p[0].set(-2);
p[1].set(2);
p[2].set(0, 0, -2);
p[3].set(0, 0, 2);
p[4] = p[0].mediate(p[2]);
p[5] = p[2].mediate(p[1]);
p[6] = p[1].mediate(p[3]);
p[7] = p[3].mediate(p[0]);
p[4] *= p[5] *= p[6] *= p[7].shift(0, 1);
Path pa(&p[0], "..", &p[4], "...", &p[2],
        "..", &p[5], "...", &p[1], "..", &p[6],
        "...", &p[3], "..", &p[7], "...", 0);
pa.draw();

```

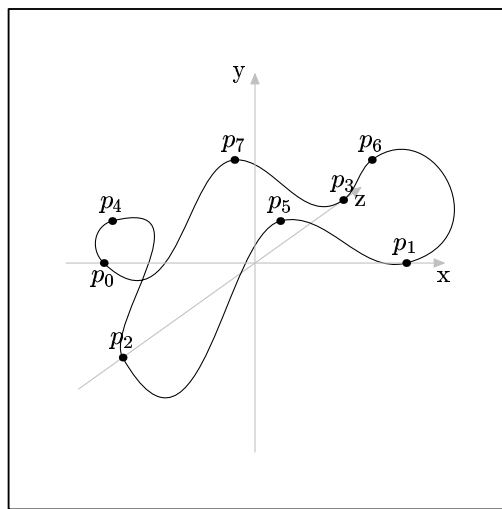

Figure 11.

As mentioned above (see Section 1.5.1 [Accuracy], page 7), specifying connectors is problematic for three-dimensional **Paths**, because MetaPost ultimately calculates the “most pleasing curve” based on the two-dimensional points in the MetaPost code written by 3DLDF.<sup>3</sup> For this reason, it’s advisable to avoid specifying ‘curl’, ‘dir’, ‘tension’ or control points in connectors. The more **Points** a (3DLDF) **Path** or other object contains, the less freedom MetaPost has to determine the (MetaPost) **path** through them. So a three-dimensional **Path** or other object in 3DLDF should have enough **Points** to ensure satisfactory results. The **Path** in Fig. 11 does not really have enough **Points**. It may require some trial and error to determine what a sufficient number of **Points** is in a given case.

**Paths** are very flexible, but not always convenient. 3DLDF provides a number of classes representing common geometric **Shapes**, which will be described in subsequent sections, and I intend to add more in the course of time.

<sup>3</sup> Knuth, *The METAFONTbook*, Chapter 14, p. 127.

## 6.2 Drawing and Filling Paths

The easiest way to draw a Path is with no arguments.

```
Point pt[5];
pt[0].set(-1, -2);
pt[1].set(0, -3);
pt[2].set(1, 0);
pt[3].set(2, 1);
pt[4].set(-1, 2);
Path pa("..", true, &pt[0], &pt[1], &pt[2], &pt[3], &pt[4], 0);
pa.draw();
```

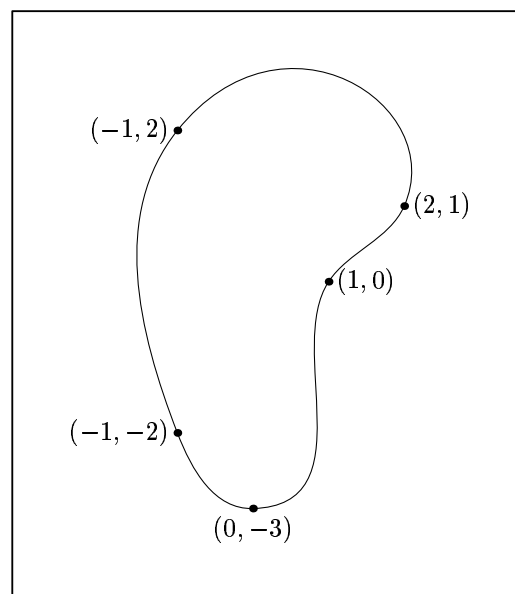

Figure 12.

Since `pa` is closed, it can be filled as well as drawn. The following example uses `fill()` with a `Color` argument, in order to avoid having a large splotch of black on the page. Common `Colors` are declared in the namespace `Colors`. See Chapter 16 [Color Reference], page 87.

```
pa.fill(Colors::gray);
```

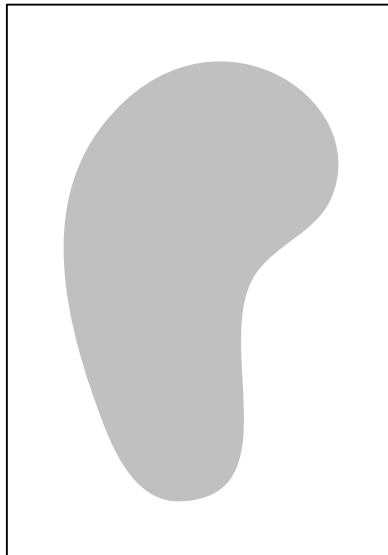

Figure 13.

Closed **Paths** can be filled and drawn, using the function `filldraw()`. This function draws the **Path** using the pen specified, or MetaPost's `currentpen` by default. A **Color** for drawing the **Path** can also be specified, otherwise, the default color (currently `Colors::black`) is used. In addition, the **Path** is filled using a second **Color**, which can be specified, or the `background_color` (`Colors::background_color`), by default. Filling a **Path** using the background color causes it to hide objects that lie behind it. See Section 9.3 [Surface Hiding], page 66, for a description of the surface hiding algorithm, and examples. Currently, this algorithm is quite primitive and only works for simple cases.

```
Point p0(-3, 0, 1);  
Point p1(3, 1, 1);  
p0.draw(p1);  
pa.filldraw();
```

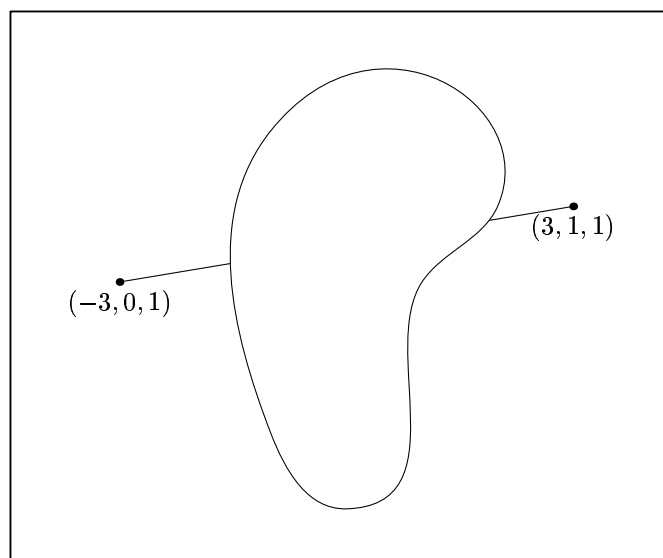

Figure 14.

The following example uses arguments for the `Colors` used for drawing and filling, and the pen. The empty string argument before the pen argument is a placeholder for the dash pattern argument.

```
pa.filldraw(black, gray, "",
            "pensquare xscaled 3mm yscaled 1mm rotated 60");
```

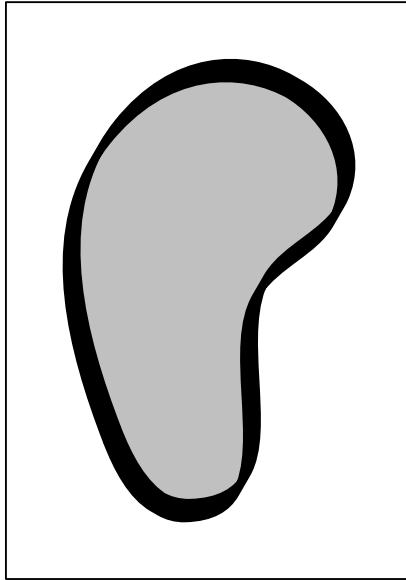

Figure 15.

Paths can also be “undrawn”, “unfilled”, and “unfilldrawn”, using the corresponding functions:

```
pa.fill(gray);
p0.undraw(p1, "", "pencircle scaled 3mm");
```

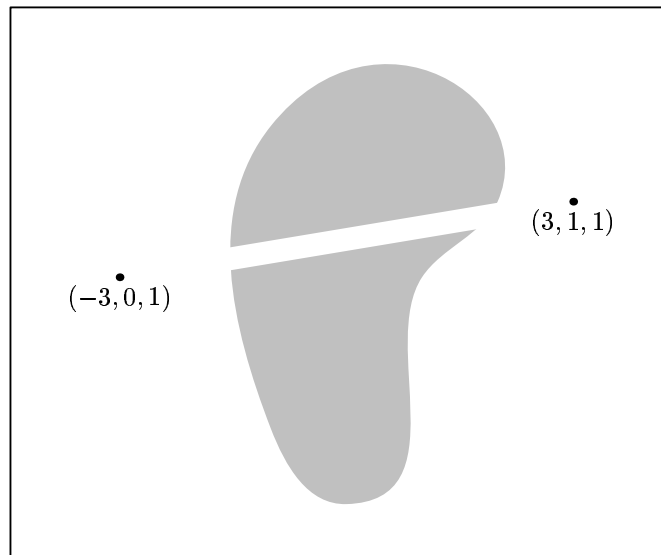

Figure 16.

```
pa.fill(gray);
```

```
Path q;  
q = pa;  
q.scale(.5, .5);  
q.unfill();
```

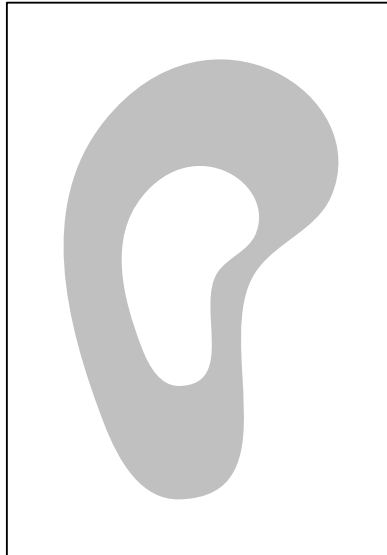

Figure 17.

The function `unfilldraw()` takes a `Color` argument for drawing the `Path`, which is `*Colors::background_color` by default. This makes it possible to unfill the `Path` while drawing the outline with a visible `Color`. On the other hand, it also makes it necessary to specify `*Colors::background_color` or `Colors::white`, if the user wants to use the dash pattern and/or pen arguments, without drawing the `Path`.

```
pa.fill(gray);  
q.unfilldraw(white, "", "pensquare xscaled 3mm yscaled 1mm");
```

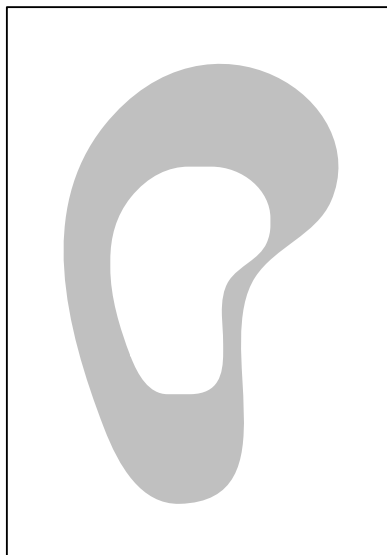

Figure 18.

The following example demonstrates the use of `unfilldraw()` with `black` as its `Color` argument. Unfortunately, it also demonstrates one of the limitations of the surface hiding algorithm: The line from `p0` to `p1` is hidden by the filled `Path pa`. Since the portion of `pa` covered by `Path q` has been unfilled,  $\overrightarrow{p_0p_1}$  should be visible as it passes through `q`. However, from the point of view of 3DLDF, there is no relationship between `pa` and `q`; nor does it “know” whether a `Path` has been filled or unfilled. If it’s on a `Picture`, it will hide objects lying behind it, unless the surface hiding algorithm fails for another reason. See Section 9.3 [Surface Hiding], page 66, for more information.

```
p0.draw(p1);  
pa.fill(gray);  
q.unfilldraw(black, "", "pensquare xscaled 3mm yscaled 1mm");
```

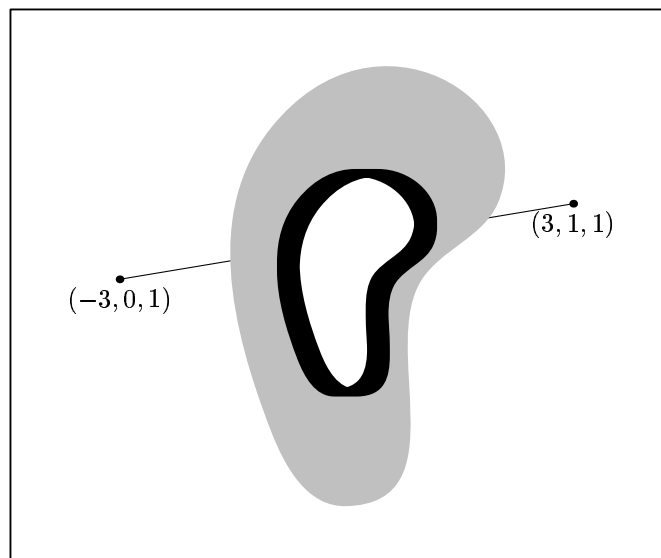

Figure 19.

See Section 26.12 [Paths; Drawing and Filling], page 179, for more information, and complete descriptions of the functions.

## 7 Plane Figures

3DLDF currently includes the following classes representing plane geometric figures: `Polygon`, `Reg_C1_Plane_Curve` (“Regular Closed Plane Curve”), `Reg_Polygon` (“Regular Polygon”), `Rectangle`, `Ellipse` and `Circle`. `Polygon` and `Reg_C1_Plane_Curve` are derived from `Path`, `Reg_Polygon` and `Rectangle` are derived from `Polygon`, and `Ellipse` and `Circle` are derived from `Reg_C1_Plane_Curve`. `Polygon` and `Reg_C1_Plane_Curve` are meant to be used as base classes only, so objects of these types should normally never be declared.

Since `Reg_Polygon`, `Rectangle`, `Ellipse`, and `Circle` all ultimately derive from `Path`, they are really just special kinds of `Path`. In particular, they inherit their drawing and filling functions from `Path`, and their transformation functions take the same arguments as the `Path` versions. They also have constructors and setting functions that work in a similar way, with a few minor differences, to account for their different natures. See Chapter 27 [Polygon Reference], page 198, Chapter 29 [Rectangle Reference], page 210, Chapter 31 [Ellipse Reference], page 221, and Chapter 32 [Circle Reference], page 237, for complete information on these classes.

### 7.1 Regular Polygons

The following example creates a pentagon in the x-z plane, centered about the origin, whose enclosing circle has a radius equal to 3cm.

```
default_focus.set(2, 3, -10, 2, 3, 10, 10);
Reg_Polygon p(origin, 5, 3);
p.draw();
```

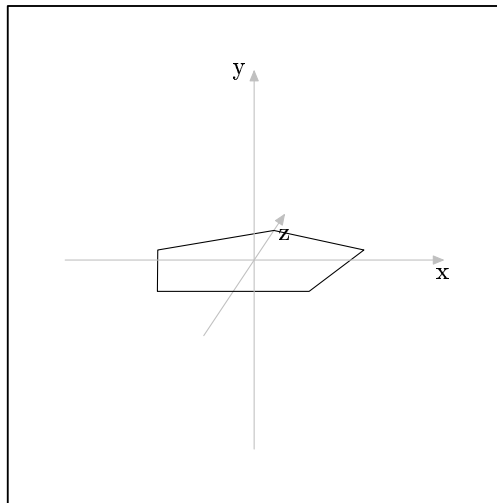

Figure 20.

Three additional arguments cause the pentagon to be rotated about the x, y, and z axes by the amount indicated. In this example, it's rotated  $90^\circ$  about the x-axis, so that it comes to lie in the x-y plane:

```
Reg_Polygon p(origin, 5, 3, 90);
```

```
p.draw();
```

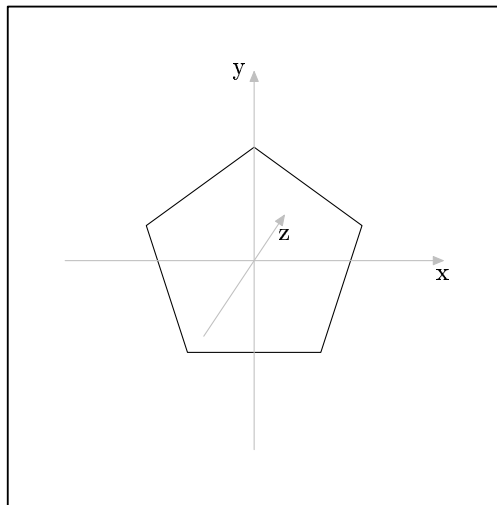

Figure 21.

In this example, it's rotated  $36^\circ$  about the y-axis, so that it appears to point in the opposite direction from the first example:

```
Reg_Polygon p(origin, 5, 3, 0, 36);  
p.draw();
```

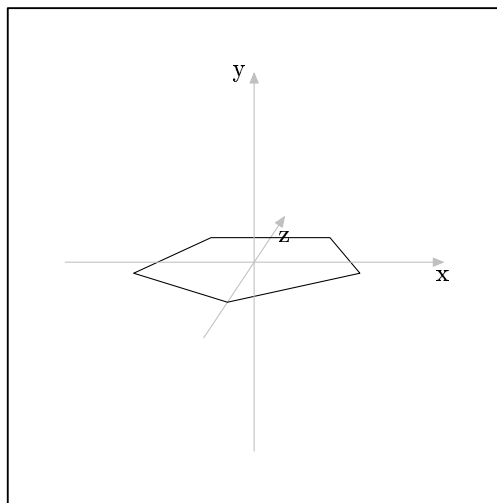

Figure 22.

In this example, it's rotated  $90^\circ$  about the z-axis, so that it lies in the z-y plane:

```
Reg_Polygon p(origin, 5, 3, 0, 0, 90);  
p.draw();
```



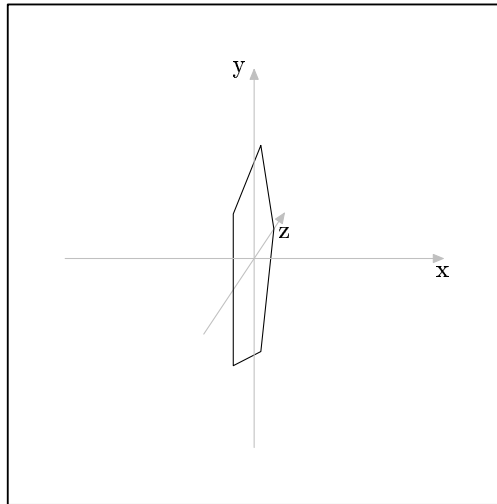

Figure 23.

In this example, it's rotated  $45^\circ$  about the x, y, and z-axes in that order:

```
Reg_Polygon p(origin, 5, 3, 45, 45, 45);
p.draw();
```

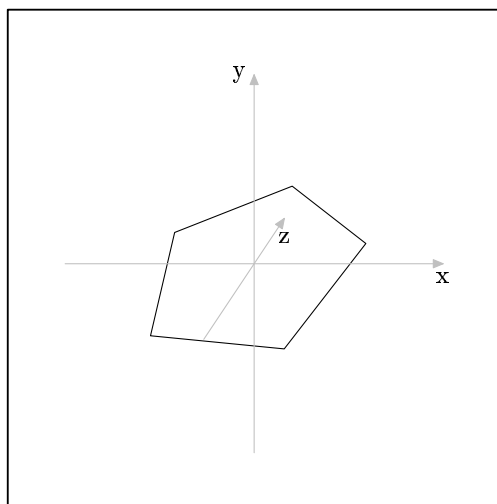

Figure 24.

**Reg\_Polygons** need not be centered about the origin. If another *Point* *pt* is used as the first argument, the **Reg\_Polygon** is first created with its center at the origin, then the specified rotations, if any, are performed. Finally, the **Reg\_Polygon** is shifted such that its center comes to lie on *pt*:

```
Point P(-2, 1, 1);
Reg_Polygon hex(P, 6, 4, 60, 30, 30);
hex.draw();
```

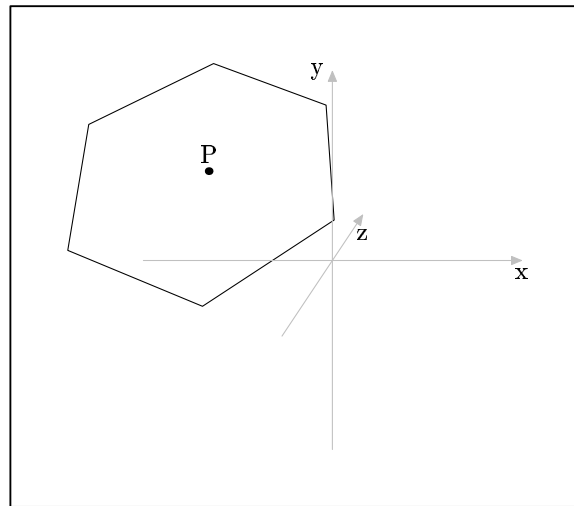

Figure 25.

In the following example, the `Reg_Polygon polygon` is first declared using the default constructor, which creates an empty `Reg_Polygon`. Then, the `polygon` is repeatedly changed using the setting function corresponding to the constructor used in the previous examples. Fig. 26 demonstrates that a given `Reg_Polygon` need not always have the same number of sides.

```
Point p(0, -3);
Reg_Polygon polygon;
for (int i = 3; i < 9; ++i)
{
    polygon.set(p, i, 3);
    polygon.draw();
    p.shift(0, 1);
}
```

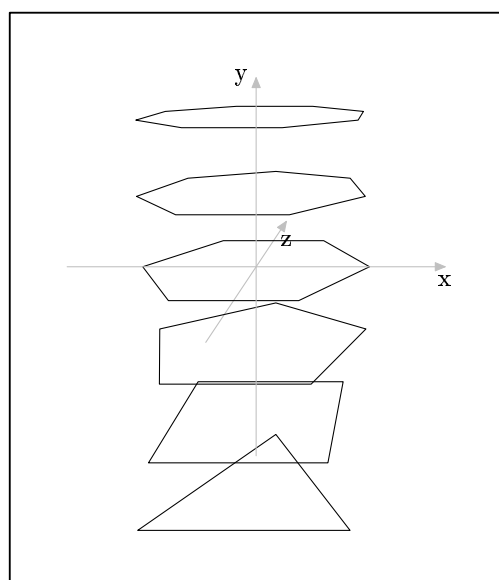

Figure 26.

## 7.2 Rectangles

A **Rectangle** can be constructed in the  $x$ - $z$  plane by specifying a center **Point**, the width, and the height:

```
Rectangle r(origin, 2, 3);  
r.draw();
```

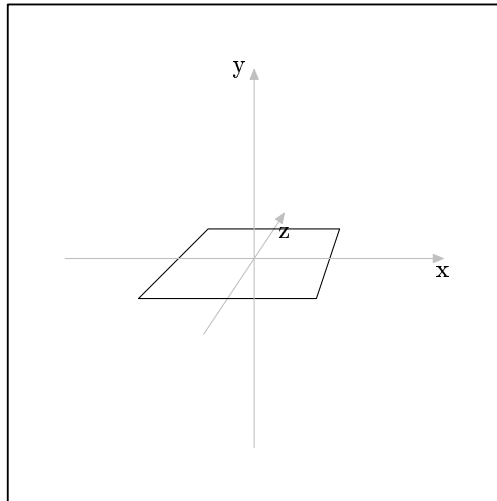

Figure 27.

Three additional arguments can be used to specify rotation about the  $x$ ,  $y$ , and  $z$ -axes respectively:

```
Rectangle r(origin, 2, 3, 30, 45, 15);  
r.draw();
```

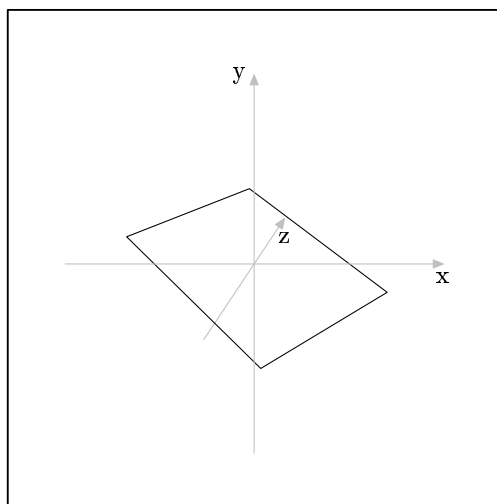

Figure 28.

If a **Point**  $p$  other than the origin is specified as the center of the **Rectangle**, the latter is first created in the  $x$ - $z$  plane, centered about the origin, as above. Then, any rotations specified are performed. Finally, the **Rectangle** is shifted such that its center comes to lie at  $p$ :

```

Point p0(.5, 1, 3);
Rectangle r(p0, 4, 2, 30, 30, 30);
r.draw();

```

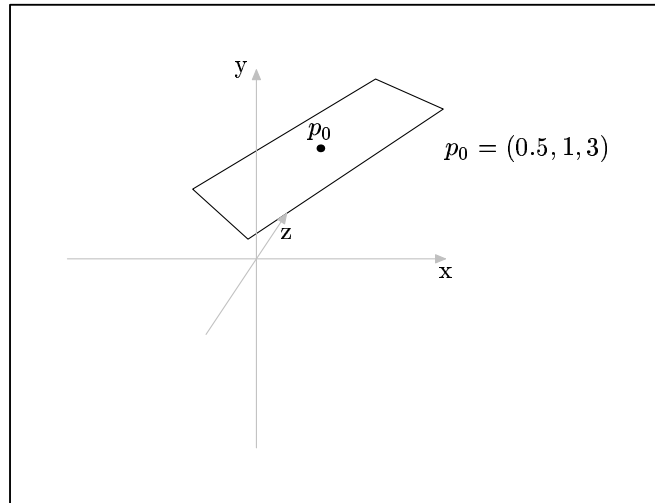

Figure 29.

This constructor has a corresponding setting function:

```

Rectangle r;
for (int i = 0; i < 180; i += 30)
{
    r.set(origin, 4, 2, i);
    r.draw();
}

```

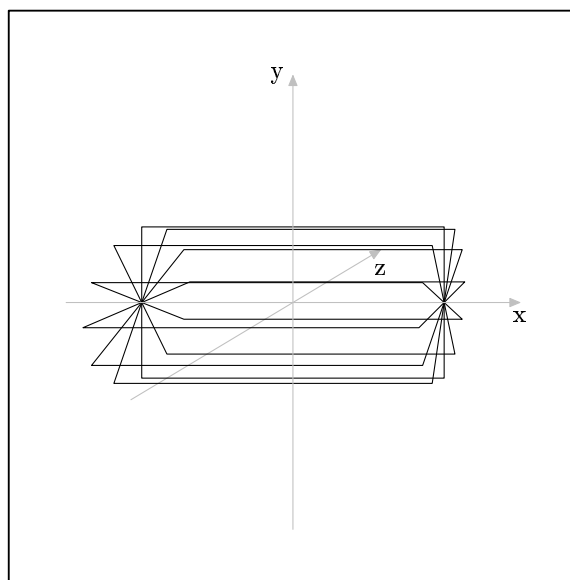

Figure 30.

**Rectangles** can also be specified using four **Points** as arguments, whereby they must be ordered so that they are contiguous in the resulting **Rectangle**:

```
Point pt[4];
pt[0].shift(-1, -2);
pt[2] = pt[1] = pt[0];
pt[1].rotate(180);
pt[3] = pt[1];
pt[2] *= pt[3].rotate(0, 180);
Rectangle r(pt[0], pt[2], pt[3], pt[1]);
r.draw();
```

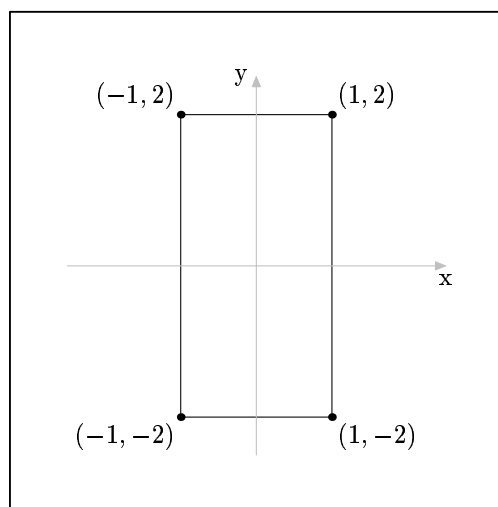

Figure 31.

This constructor checks whether the `Point` arguments are coplanar, however, it does not check whether they are really the corners of a valid rectangle; the user, or the code that calls this function, must ensure that they are. In the following example, `r`, although not rectangular, is a `Rectangle`, as far as 3DLDF is concerned:

```
pt[0].shift(0, -1);
pt[3].shift(0, 1);
Rectangle q(pt[0], pt[2], pt[3], pt[1]);
q.draw();
```

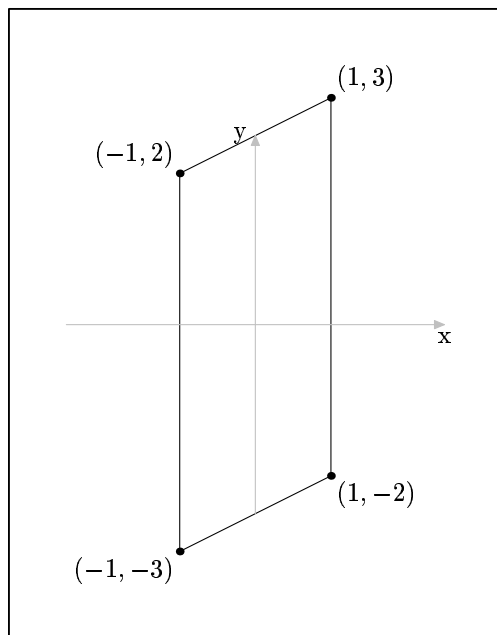

Figure 32.

This constructor is not really intended to be used directly, but should mostly be called from within other functions, that should ensure that the arguments produce a rectangular `Rectangle`. There is also no guarantee that transformations or other functions called on `Rectangle`, `Circle`, or other classes representing geometric figures won't cause them to become non-rectangular, non-circular, or otherwise irregular. Sometimes, this might even be desirable. I plan to add the function `Rectangle::is_rectangular()` soon, so that users can test `Rectangles` for rectangularity.

### 7.3 Ellipses

`Ellipse` has a constructor similar to those for `Reg_Polygon` and `Rectangle`. The first argument is the center of the `Ellipse`, and the following two specify the lengths of the horizontal and vertical axes respectively. The `Ellipse` is first created in the x-z plane, centered about the origin. The horizontal axis lies along the x-axis and the vertical axis lies along the z-axis. The three subsequent arguments specify the amounts of rotation about the x, y, and z-axes respectively and default to 0. Finally, `Ellipse` is shifted such that its center comes to lie at the `Point` specified in the first argument.

```
Point pt(-1, 1, 1);
Ellipse e(pt, 3, 6, 90);
e.draw();
```

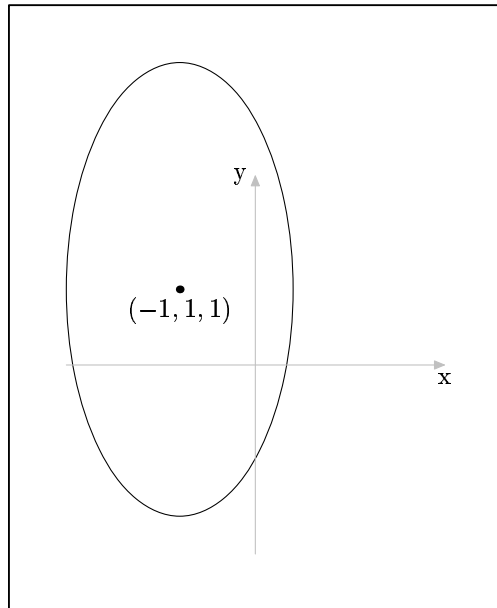

Figure 33.

As you may expect, this constructor has a corresponding setting function:

```
Ellipse e;  
real h_save = 1.5;  
real v_save = 2;  
real h = h_save;  
real v = v_save;  
Point p(-1);  
for (int i = 0; i < 5; ++i)  
{  
    e.set(p, h, v, 90);  
    e.draw();  
    h_save += .25;  
    v_save += .25;  
    h *= sqrt(h_save);  
    v *= sqrt(v_save);  
    p.shift(0, 0, 2);  
}
```

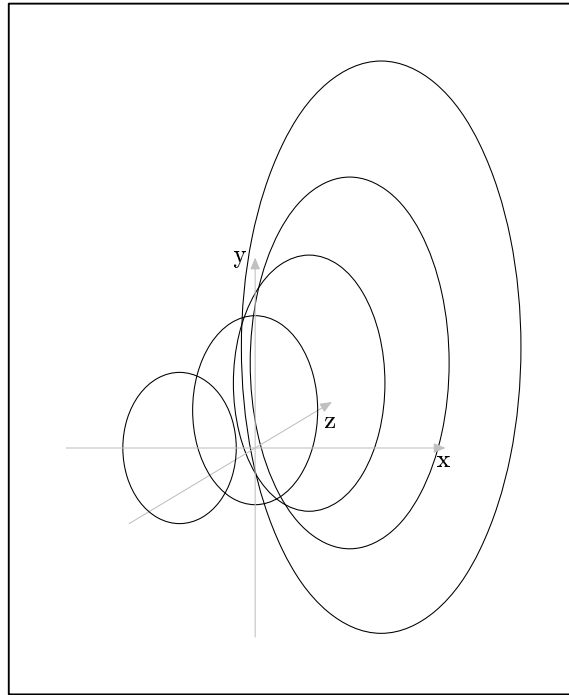

Figure 34.

## 7.4 Circles

**Circles** are constructed just like **Ellipses**, except that the vertical and horizontal axes are per definition the same, so there's only one argument for the diameter, instead of two for the horizontal and vertical axes:

```
Point P(0, 2, 1);  
Circle c(P, 3.5, 90, 90);  
c.draw();
```

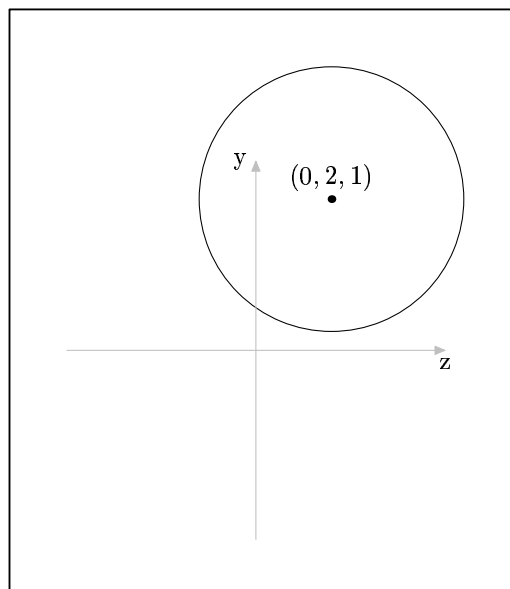

Figure 35.



This constructor, too, has a corresponding setting function:

```
Circle c;  
Point p(-1, 0, 5);  
for (int i = 0; i < 16; ++i)  
{  
    c.set(p, 5, i * 22.5, 0, 0, 64);  
    c.draw();  
}
```

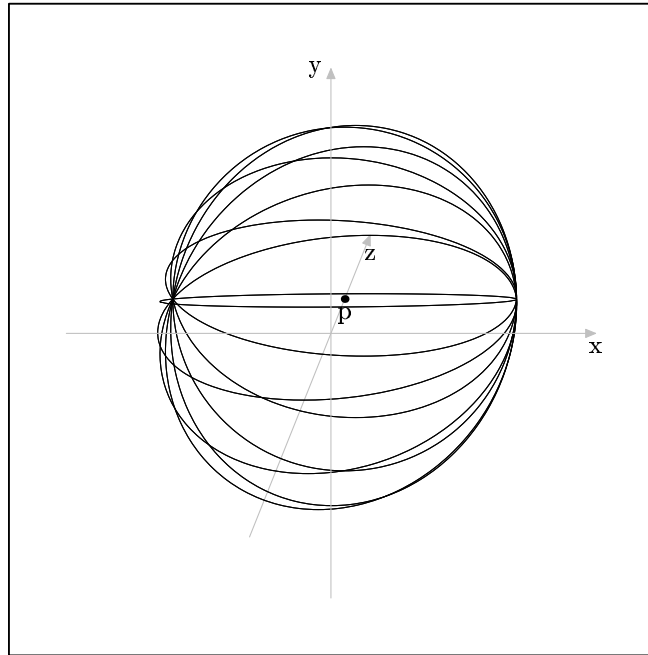

Figure 36.

In the preceding example, the last argument to `set()`, namely “64”, is for the number of `Points` used for constructing the perimeter of the `Circle`. The default value is 16, however, if it is used, foreshortening distorts the most nearly horizontal `Circle`. Increasing the number of points used improves its appearance. However, there may be a limit to how much improvement is possible. See Section 1.5.1 [Accuracy], page 7.

## 8 Solid Figures

### 8.1 Cuboids

A *cuboid* is a solid figure consisting of six rectangular faces that meet at right angles. A cube is a special form of cuboid, whose faces are all squares. The constructor for the class `Cuboid` follows the pattern familiar from the constructors for the plane figures: The first argument is the center of the `Cuboid`, followed by three `real` arguments for the height, width, and depth, and then three more `real` arguments for the angles of rotation about the x, y, and z-axes. The `Cuboid` is first constructed with its center at the origin. Its width, height, and depth are measured along the x, y, and z-axes respectively. If rotations are specified, it is rotated about the x, y, z-axes in that order. Finally, it is shifted such that its center comes to lie on its `Point` argument, if the latter is not the origin.

If the width, height, and depth arguments are equal, the `Cuboid` is a cube:

```
Cuboid c0(origin, 3, 3, 3, 0, 30);  
c0.draw();
```

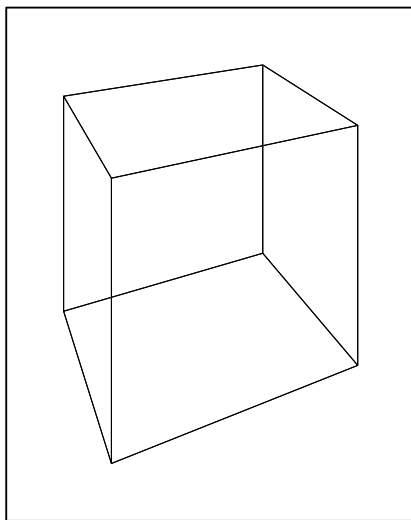

Figure 37.

In the following example, the `Cuboid` is “filldrawn”, so that the lines delineating the hidden surfaces of the `Cuboid` are covered.

```
Cuboid c1(origin, 3, 4, 5, 0, 30);  
c1.filldraw();
```

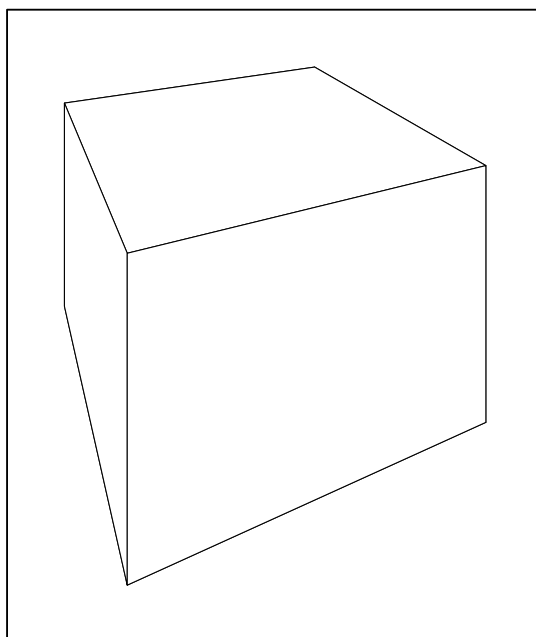

Figure 38.

## 8.2 Polyhedron

The class `Polyhedron` is meant for use only as a base class; no objects of type `Polyhedron` should be declared. Instead, there is a class for each of the different drawable polyhedra. Currently, 3DLDF defines only three: `Tetrahedron`, `Dodecahedron`, and `Icosahedron`. There's no need for a `Cube` class, because cubes can be drawn using `Cuboid` (see Section 8.1 [Cuboid Getstart], page 46).

Polyhedra have a high priority in my plans for 3DLDF. I intend to add `Octahedron` soon, which will complete the set of regular Platonic polyhedra. Then I will begin adding the semi-regular Archimedean polyhedra, and their duals.

The constructors for the classes derived from `Polyhedron` follow the pattern familiar from the classes already described. The constructors for the classes described below have identical arguments: First, a `Point` specifying the center, then a `real` for the diameter of the surrounding circle (*Umkreis*, in German) of one of its polygonal faces, followed by three `real` arguments for the angles of rotation about the main axes.

### 8.2.1 Tetrahedron

The center of a tetrahedron is the intersection of the lines from a vertex to the center of the opposite side. At least, in 3DLDF, this is the `center` of a `Tetrahedron`. I'm not 100° certain that this is mathematically correct.

```
Tetrahedron t(origin, 4);
t.draw();
t.get_center().dotlabel("$c$");
```

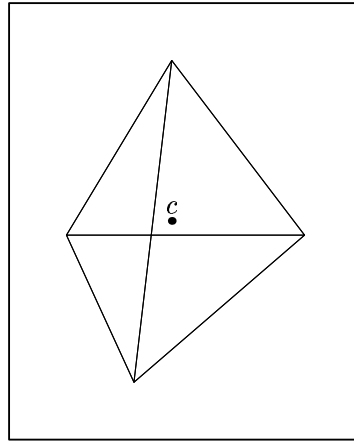

Figure 39.

### 8.2.2 Dodecahedron

A dodecahedron has 12 similar regular pentagonal faces. The following examples show the same Dodecahedron using different projections:

```
default_focus.set(2, 5, -10, 2, 5, 10, 10);  
Dodecahedron d(origin, 3);  
d.draw();
```

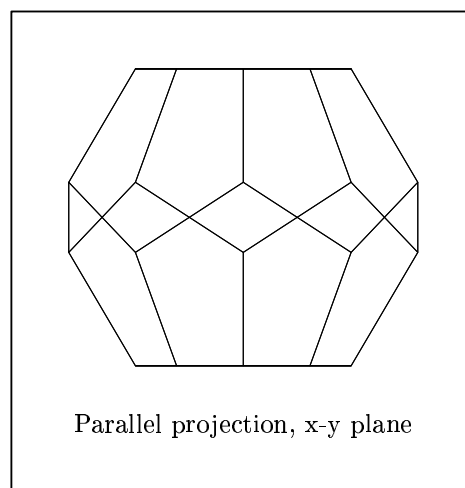

Figure 40.

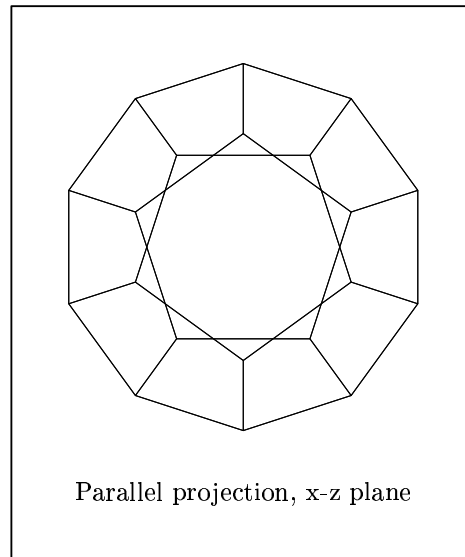

Figure 41.

Please note that the Dodecahedron in Fig. 42 is drawn, and not filldrawn!

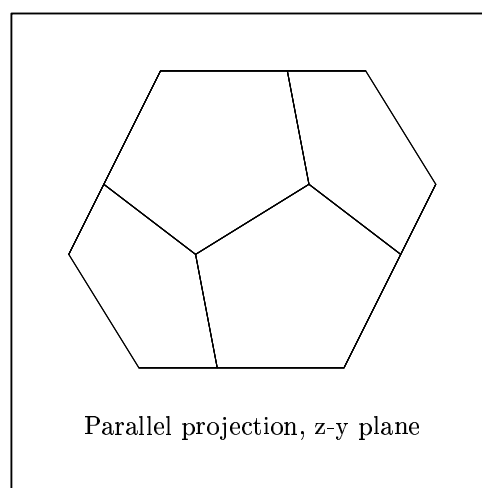

Figure 42.

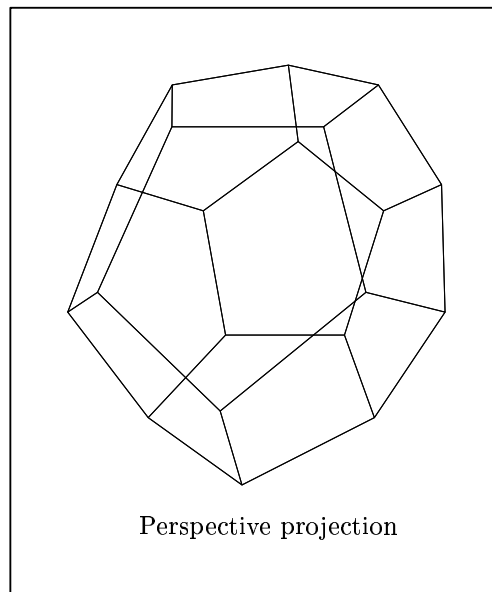

Figure 43.

In Fig. 44, `d` is `filldrawn`. In this case, the surface hiding algorithm has worked properly. See Section 9.3 [Surface Hiding], page 66.

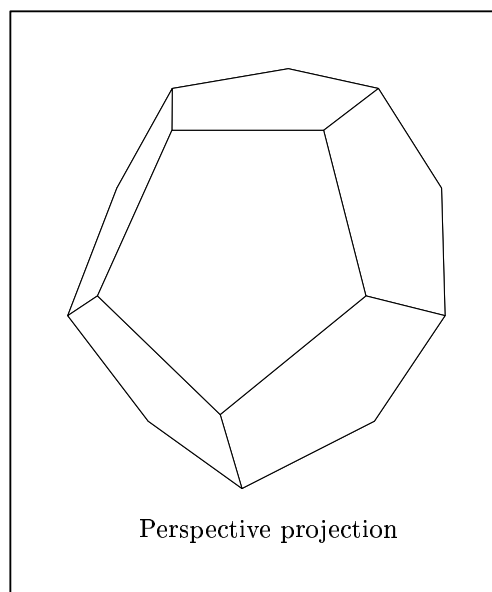

Figure 44.

### 8.2.3 Icosahedron

An icosahedron has 20 similar regular triangular faces. The following examples show the same `Icosahedron` using different projections:

```
default_focus.set(3, 0, -10, 2, 0, 10, 10);  
Icosahedron i(origin, 3);  
i.draw();
```

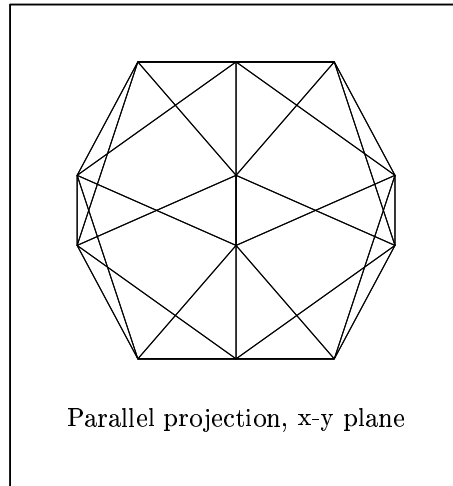

Figure 45.

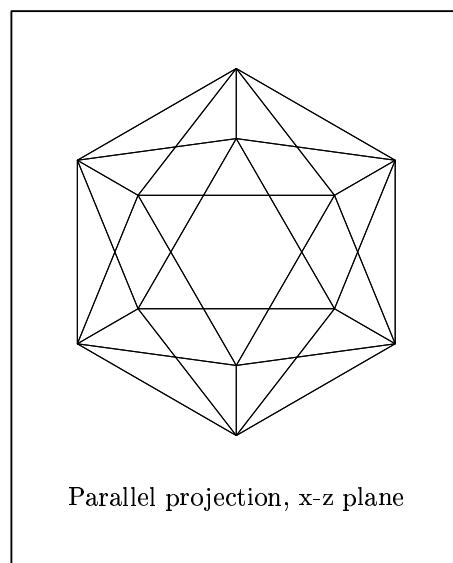

Figure 46.

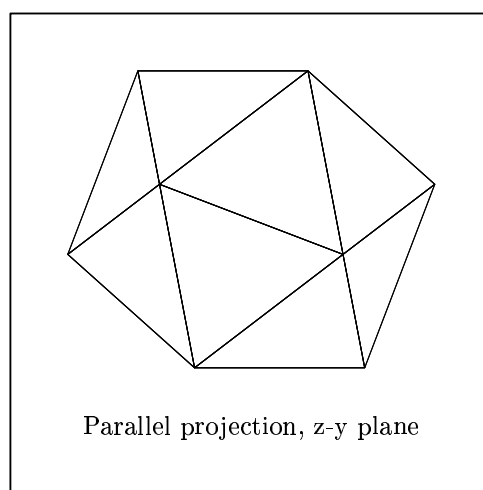

Figure 47.

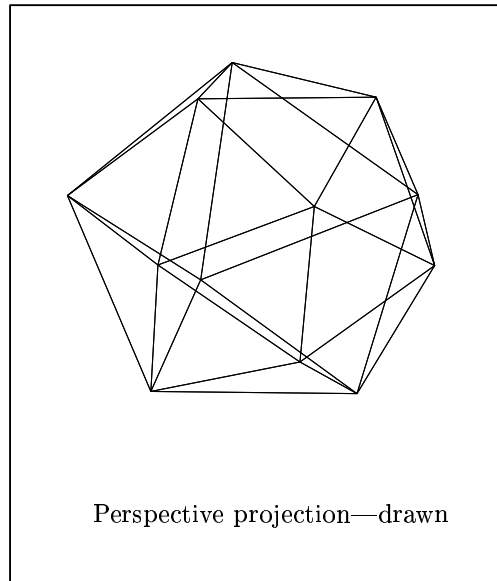

Figure 48.

In Fig. 49, `i` is `filldrawn`. In this case, the surface hiding algorithm has worked properly. See Section 9.3 [Surface Hiding], page 66.

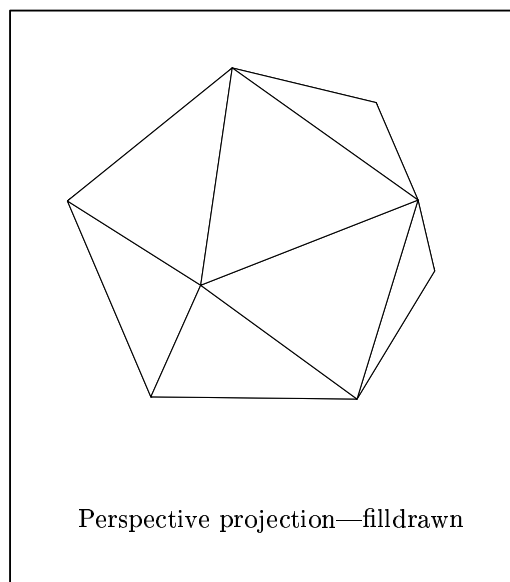

Figure 49.



## 9 Pictures

Applying drawing and filling operations to the drawable objects described in the previous chapters isn't enough to produce output. These operations merely modify the `Picture` object that was passed to them as an argument (`current_picture`, by default).

`Pictures` in 3DLDF are quite different from `pictures` in MetaPost. When a drawing or filling operation is applied to an object  $O$ , a copy of  $O$ ,  $C$ , is allocated on the free store, a pointer to `Shape`  $S$  is pointed at  $C$ , and  $S$  is pushed onto the `vector<Shape*> shapes` on the `Picture`  $P$ , which was passed as an argument to the drawing or filling command. The arguments for the pen, dash pattern, `Color`, and any others, are used to set the corresponding data members of  $C$  (not  $O$ ).

In order to actually cause MetaPost code to be written to the output file, it is necessary to invoke `P.output()`. Now, the appropriate version of `output()` is applied to each of the objects pointed to by a pointer on `P.shapes`. `output()` is a pure virtual function in `Shape`, so all classes derived from `Shape` must have an `output()` function. So, if `shapes[0]` points to a `Path`, `Path::output()` is called, if `shapes[1]` points to a `Point`, `Point::output()` is called, and if `shapes[2]` points to an object of a type derived from `Solid`, `Solid::output()` is called. `Point`, `Path`, and `Solid` are namely the only classes derived from `Shape` for which a version of `output()` is defined. All other `Shapes` are derived from one of these classes. These `output()` functions then write the MetaPost code to the output file through the output file stream `out_stream`.

```
beginfig(1);
default_focus.set(0, 0, -10, 0, 0, 10, 10);
Circle c(origin, 3, 90);
c.draw();
c.shift(1.5);
c.draw();
current_picture.output();
endfig(1);
```

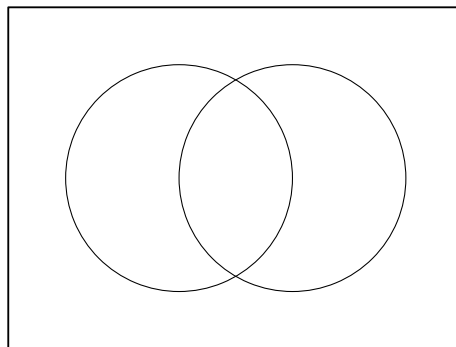

Figure 50.

The C++ code for Fig. 50 starts with the command `beginfig(1)` and ends with the command `endfig(1)`. They simply write “`beginfig({arg})`” and “`endfig()`” to `out_stream`. The optional `unsigned int` argument to `endfig()` is not written to `out_stream`, it's merely “syntactic sugar” for the user.

In MetaPost, the `endfig` command causes output and then clears `currentpicture`. This is not the case in 3DLDF, where `Picture::output()` and `Picture::clear()` must be invoked explicitly:

```
beginfig(1);
Point p0;
Point p1(1, 2, 3);
p0.draw(p1);
current_picture.output();
endfig(1);

beginfig(2);
current_picture.clear();
Circle C(origin, 3);
C.fill();
current_picture.output();
endfig(2);
```

In Fig. 51, two `Pictures` are used within a single figure.

```
beginfig(1);
Picture my_picture;
default_focus.set(0, 0, -10, 0, 0, 10, 10);
Circle c(origin, 3, 90);
c.draw(my_picture);
my_picture.output();
c.shift(1.5);
c.fill(light_gray);
current_picture.output();
endfig(1);
```

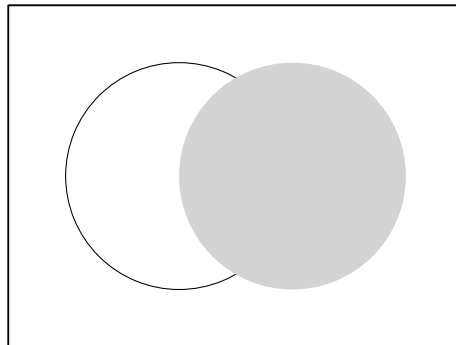

Figure 51.

Multiple objects, or complex objects made up of sub-objects, can be stored in a `Picture`, so that operations can be applied to them as a group:

```
default_focus.set(7, 5, -10, 7, 5, 10, 10);
Cuboid c0(origin, 5, 5, 5);
c0.shift(0, 0, 3);
c0.draw();
Circle z0(c0.get_rectangle_center(0), 2.5, 90, 0, 0, 64);
```

```
z0.draw();
Circle z1(z0);
z1.shift(0, 0, -1);
z1.draw();
int i;
int j = z0.get_size();
for (i = 0; i < 8; ++i)
    z0.get_point(i * j/8).draw(z1.get_point(i * j/8));
Cuboid c1(c0.get_rectangle_center(4), 5, 3, 3);
c1.shift(0, 2.5);
c1.draw();
Rectangle r0 = *c1.get_rectangle_ptr(3);
Point p[10];
for (i = 0; i < 4; ++i)
    p[i] = r0.get_point(i);
p[4] = r0.get_mid_point(0);
p[5] = r0.get_mid_point(2);
p[6] = p[4].mediate(p[5], 2/3.0);
Circle z2(p[6], 2, 90, 90, 0, 16);
z2.draw();
Circle z3 = z2;
z3.shift(3);
z3.draw();
j = z2.get_size();
for (i = 0; i < 8; ++i)
    z2.get_point(i * j/8).draw(z3.get_point(i * j/8));
p[7] = c0.get_rectangle_center(2);
p[7].shift(-4);
p[8] = c0.get_rectangle_center(3);
p[8].shift(4);
current_picture.output();
current_picture.rotate(45, 45);
current_picture.shift(10, 0, 3);
current_picture.output();
```

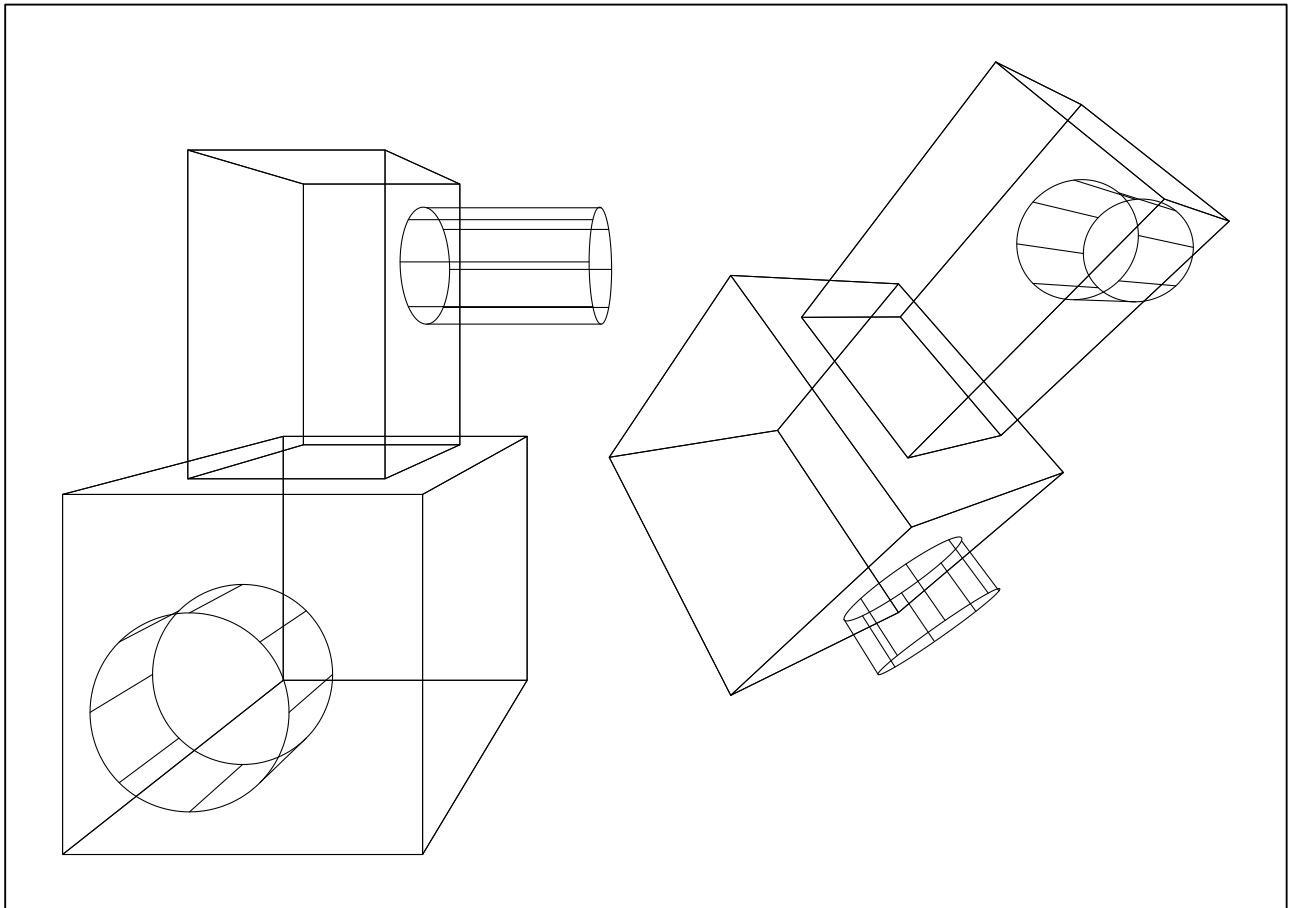

Figure 52.

Let's say the complex object in Fig. 52 represents a furnace. From the point of view of 3DLDF, however, it's not an object at all, and the drawing consists of a collection of unrelated `Cuboids`, `Circles`, `Rectangles`, and `Paths`. If we hadn't put it into a `Picture`, we could still have rotated and shifted it, but only by applying the operations to each of the sub-objects individually.

One consequence of the way `Pictures` are output in 3DLDF is, that the following code will not work:

```
beginfig(1);
Point p(1, 2);
Point q(1, 3);
out_stream << "pickup pencircle scaled .5mm;" << endl;
origin.draw(p);
out_stream << "pickup pensquare xscaled .3mm rotated 30;" << endl;
origin.draw(q);
current_picture.output();
endfig();
```

This is the MetaPost code that results:

```
beginfig(1);
pickup pencircle scaled .5mm;
pickup pensquare xscaled .3mm rotated 30;
```

```

draw (0.000000cm, -3.000000cm) -- (1.000000cm, -1.000000cm);
draw (0.000000cm, -3.000000cm) -- (1.000000cm, 0.000000cm);
endfig;

```

It's perfectly legitimate to write raw MetaPost code to `out_stream`, as in lines 4 and 6 of this example. However, the `draw()` commands do not cause any output to `out_stream`. The MetaPost drawing commands are written to `out_stream` when `current_picture.output()` is called. Therefore, the `pickup` commands are “bunched up” before the drawing commands. In this example, setting `currentpen` to `pencircle scaled .5mm` has no effect, because it is immediately reset to `pensquare xscaled .3mm rotated 30` in the MetaPost code, before the `draw` commands. It is not possible to change `currentpen` in this way within a `Picture`. Since the `draw()` commands in the 3DLDF code didn't specify a `pen` argument, `currentpen` with its final value is used for both of the MetaPost `draw` commands. For any given invocation of `Picture::output()`, there can only be one value of `currentpen`. All other pens must be passed as arguments to the drawing commands.

## 9.1 Projections

In order for a 3D graphic program to be useful, it must be able to make two-dimensional projections of its three-dimensional constructions so that they can be displayed on computer screens and printed out. These are some of the possible projections:

- Parallel projection onto one of the major planes  
These projections are trivial, and can be performed by 3DLDF. They are discussed in the following section.
- Parallel projection onto another plane  
I haven't programmed these projections yet, but they might be useful, so I probably will, when I get around to it.
- The perspective projection  
This is the projection most people think of, when they think of 3D-graphics. It is discussed in detail in Section 9.1.2 [The Perspective Projection], page 59.
- The isometric and axonometric projections  
These projections are important for engineering and drafting. I have not yet implemented them in 3DLDF, but they are on my list of “Things To Do”.

The function `Picture::output()` takes a `const unsigned short` argument specifying the projection to be used. The user should probably avoid using explicit `unsigned shorts`, but should use the constants defined for this purpose in the namespace `Projections`.<sup>1</sup> The constants are `PERSP`, `PARALLEL_X_Y`, `PARALLEL_X_Z`, `PARALLEL_Z_Y`, `AXON`, and `ISO`. The latter two should not be used, because the axonometric and isometric projections have not yet been implemented.

### 9.1.1 Parallel Projections

When a `Picture` is projected onto the x-y plane, the x and y-values from the `world_coordinates` of the `Points` belonging to the objects on the `Picture` are copied to their

<sup>1</sup> Namespaces are described in Stroustrup, *The C++ Programming Language*, Chapter 8.

`projective_coordinates`, which are used in the MetaPost code written to `out_stream`. If a `Picture p` contains an object in the x-y plane, or in a plane parallel to the x-y plane, then the result of `p.output(Projections::PARALLEL_X_Y)` is more-or-less equivalent to just using MetaPost without 3DLDF.

```
Rectangle r(origin, 3, 3, 90);
Circle c(origin, 3, 90);
c *= r.shift(0, 0, 5);
r.draw();
c.draw();
current_picture.output(Projections::PARALLEL_X_Y);
```

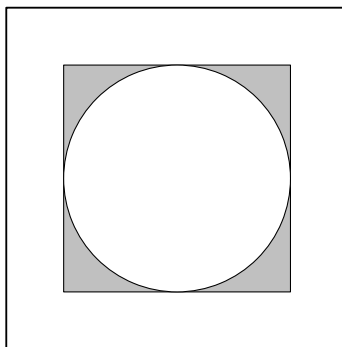

Figure 53.

If the objects do not lie in the x-y plane, or a plane parallel to the x-y plane, then the projection will be distorted:

```
current_picture.output(Projections::PARALLEL_X_Y);
```

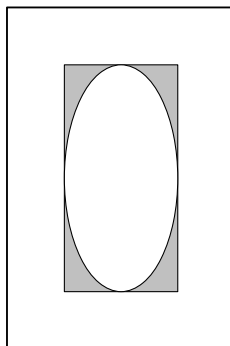

Figure 54.

`Picture::output()` can be called with an additional `real` argument *factor* for magnifying or shrinking the `Picture`.

```
Rectangle r(origin, 4, 4, 90, 60);
Circle c(origin, 4, 90, 60);
c *= r.shift(0, 0, 5);
r.filldraw(black, gray);
c.unfilldraw(black);
current_picture.output(Projections::PARALLEL_X_Y, .5);
current_picture.shift(2.5);
current_picture.output(Projections::PARALLEL_X_Y);
```

```
current_picture.shift(1);
current_picture.output(Projections::PARALLEL_X_Y, 2);
```

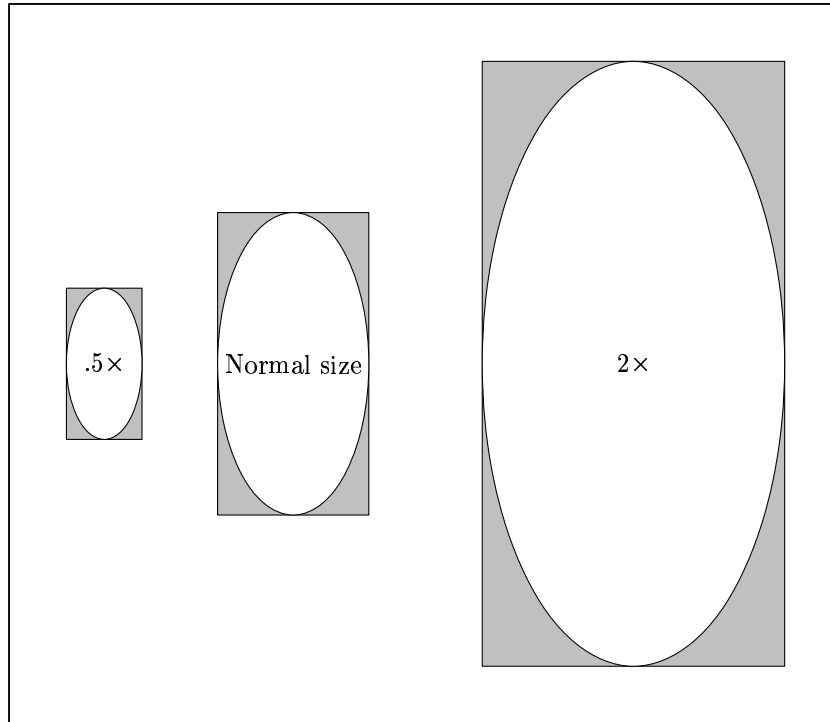

Figure 55.

Parallel projection onto the  $x$ - $z$  and  $z$ - $y$  planes are completely analogous to parallel projection onto the  $x$ - $y$  plane.

### 9.1.2 The Perspective Projection

The perspective projection obeys the laws of *linear perspective*. In 3DLDF, it is performed by means of a transformation, whose effect is, to the best of my knowledge, exactly equivalent to the result of a perspective projection done by hand using vanishing points and rulers.

It is very helpful to the artist to understand the laws of linear perspective, and to know how to make a perspective drawing by hand.<sup>2</sup> However, it is a very tedious and error-prone procedure (I know, I've done it). One of my main motivations for writing 3DLDF was so I wouldn't have to do it anymore.

Fig. 56 shows a perspective construction, the way it could be done by hand. The point of view, or *focus* is located 6cm from the picture plane, and 4cm above the ground (or  $x$ - $z$ ) plane at the point  $(0, 4, -6)$ . The rectangle  $R$  lies in the ground plane, with the point  $r_0$  at  $(2, 0, 1.5)$ . The right side of  $R$ , with length = 2 cm lies at an angle of  $40^\circ$  to the ground line, which corresponds to the intersection line of the ground plane with the picture plane, and the left side, with length = 5 cm, at an angle of  $90^\circ - 40^\circ = 50^\circ$  to the ground line.

<sup>2</sup> There are many books on linear perspective for artists. I've found Gwen White's *Perspective. A Guide for Artists, Architects and Designers* to be particularly good. Vredeman de Vries, *Perspective* contains beautiful examples of perspective constructions.

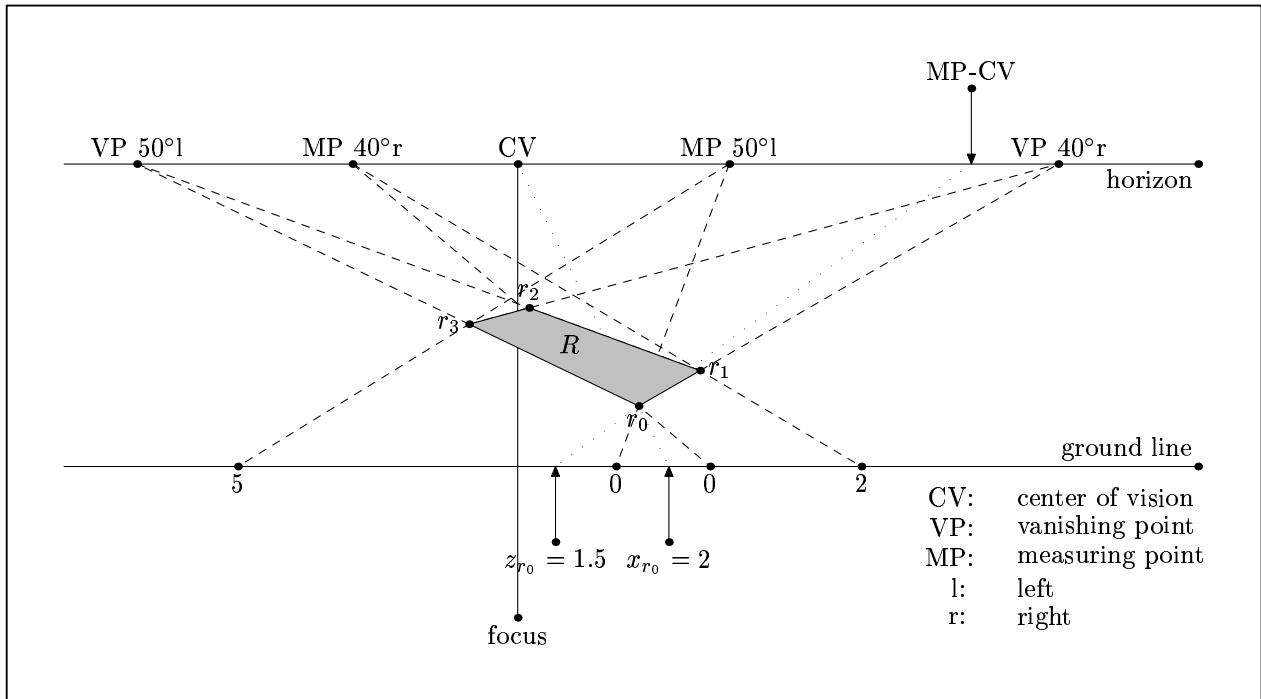

Figure 56.

While it's possible to use 3DLDF to make a perspective construction in the traditional way, as Fig. 56 shows, the code for Fig. 57 achieves the same result more efficiently:

```
default_focus.set(0, 4, -6, 0, 4, 6, 6);
Rectangle r(origin, 2, 5, 0, 40);
Point p(2, 0, 1.5);
r.shift(p - r.get_point(0));
r.draw();
```

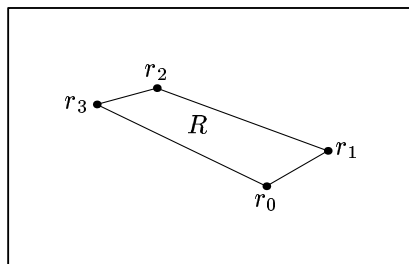

Figure 57.

In Fig. 56, it was convenient to start with the corner point  $r_0$ ; if we needed the center of  $R$ , it would have to be found from the corner points. However, in 3DLDF, `Rectangles` are most often constructed about the center. Therefore, in Fig. 58,  $R$  is first constructed about the origin, with the rotation about the y-axis passed as an argument to the constructor. It is then shifted such that `*(R.points[0])`, the first (or zeroth, if you will) `Point` on  $R$  comes to lie at  $(2, 0, 1.5)$ .

Unlike the other transformations currently used in 3DLDF, the perspective transformation is non-affine. Affine transformations maintain parallelism of lines, while the rules of



perspective state that parallel lines, with one exception, appear to recede toward a *vanishing point*.<sup>3</sup>

In Fig. 56, the lines  $\overrightarrow{r_0 r_1}$  and  $\overrightarrow{r_3 r_2}$  appear to vanish toward the right-hand  $40^\circ$  vanishing point, while  $\overrightarrow{r_0 r_3}$  and  $\overrightarrow{r_1 r_2}$  appear to vanish toward the left-hand  $50^\circ$  vanishing point. The lower the angle of a vanishing point, the further away it is from the center of vision, as Fig. 58 shows:

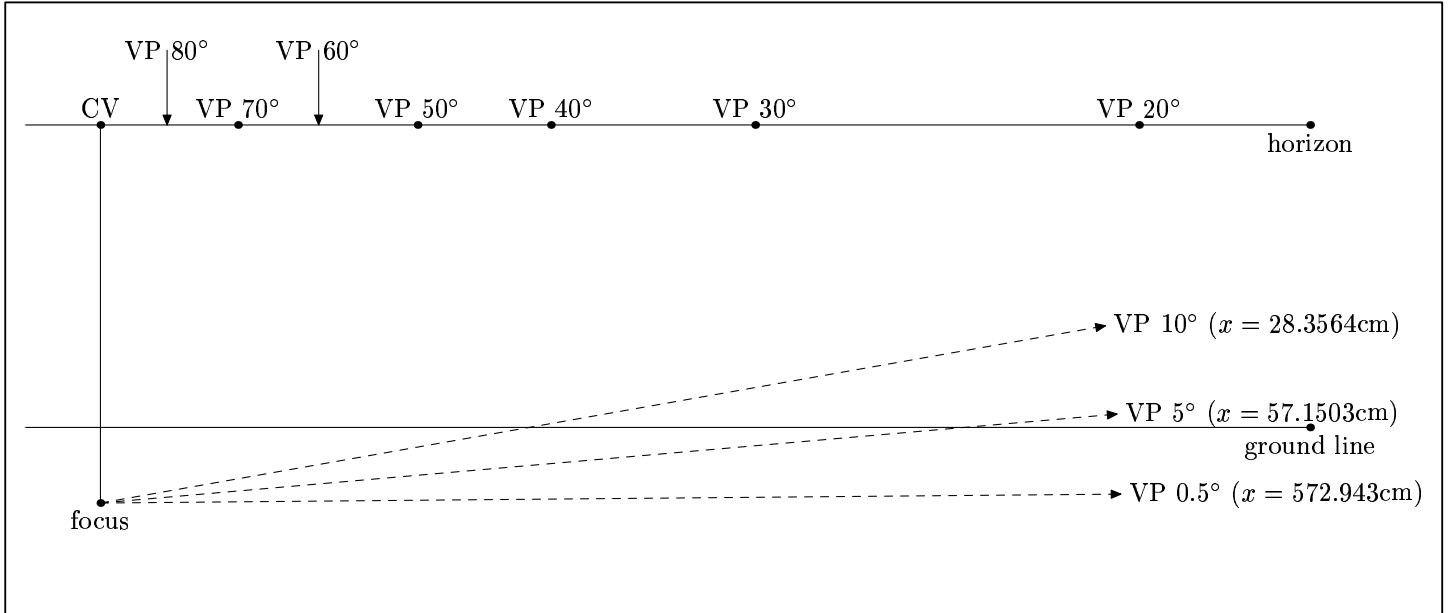

Figure 58.

In Fig. 58, the  $0.5^\circ$  vanishing point is nearly  $5\frac{3}{4}$  meters away from the CV, and a line receding to it will be very nearly horizontal. However, the distance from the focus to the CV is only 5 cm. As this distance increases, the distance from the CV to a given vanishing point increases proportionately. If the distance is 30 cm, a more reasonable value for a drawing, then the x-coordinate of VP  $10^\circ$  is 170.138 cm, that of VP  $5^\circ$  is 342.902 cm, and that of VP  $0.5^\circ$  is 3437.66 cm! This is the reason why perspective drawings done by hand rarely contain lines receding to the horizon at low angles.

This problem doesn't arise when the perspective transformation is used. In this case, any angle can be calculated as easily as any other:

```
default_focus.set(0, 4, -6, 0, 4, 6, 6);
Rectangle r;
Point center(0, 2);
r.set(center, 2, 5, 0, 0, 0.5);
r.draw();

r.set(center, 2, 5, 0, 0, 2.5);
```

<sup>3</sup> (I believe the following to be correct, but I'm not entirely sure.) Let  $\vec{v}$  be the line of sight. By definition, the plane of projection will be a plane  $p$ , such that  $\vec{v}$  is normal to  $p$ . Let  $q_0$  and  $q_1$  be planes such that  $q_0 \equiv q_1$  or  $q_0 \parallel q_1$ , and  $q_0 \perp p$ . It follows that  $q_1 \perp p$ . Let  $l_0$  and  $l_1$  be lines, such that  $l_0 \neq l_1$ ,  $l_0 \parallel l_1$ ,  $l_0 \in q_0$ ,  $l_1 \in q_1$ ,  $l_0 \perp \vec{v}$ , and  $l_1 \perp \vec{v}$ . Under these circumstances, the projections of  $l_0$  and  $l_1$  in  $p$  will also be parallel.

```

r.draw();

r.set(center, 2, 5, 0, 0, 5);
r.draw();
current_picture.output();

```

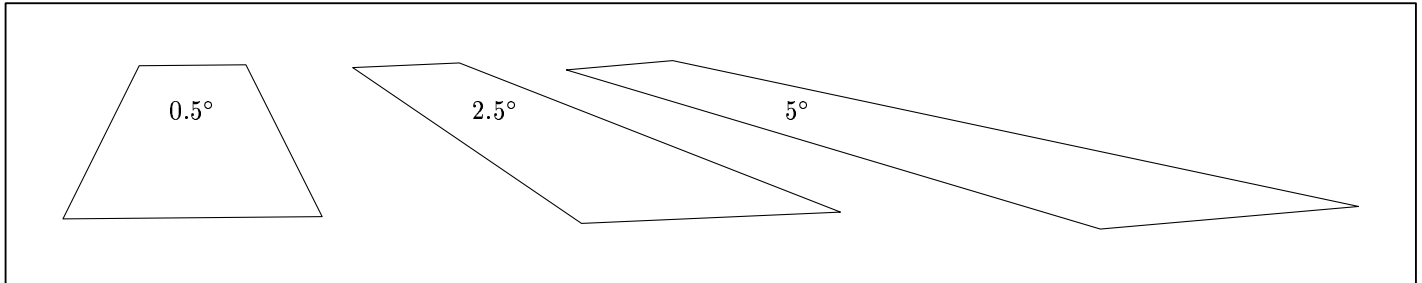

Figure 59.

## 9.2 Focuses

The perspective transformation requires a focus; as a consequence, outputting a `Picture` requires an object of class `Focus`. `Picture::output()` takes an optional pointer-to-`Focus` argument, which is 0 by default. If the default is used, (or 0 is passed explicitly), the global variable `default_focus` is used. See Section 23.2 [Focus Reference; Global Variables], page 151.

A `Focus` can be thought of as the observer of a scene, or a camera. It contains a `Point` `position` for its location with respect to 3DLDF's coordinate system, and a `Point` `direction`, specifying the direction where the observer is looking, or where the camera is pointed. The `Focus` can be rotated freely about the line  $\overrightarrow{PD}$ , where  $P$  stands for `position` and  $D$  for `direction`, so a `Focus` contains a third `Point` `up`, to indicate which direction will be “up” on the projection, when a `Picture` is projected.

The projection plane  $q$  will always be perpendicular to  $\overrightarrow{PD}$ , or to put it another way,  $\overrightarrow{PD}$  is normal to  $q$ .

Unlike the traditional perspective construction, where the distance from the focus to the center of vision fixes both the location of the focus in space, and its distance to the picture plane,<sup>4</sup> these two parameters can be set independently when the perspective transformation is used. The distance from a `Focus` to the picture plane is stored in the data member `distance`, of type `real`.

A `Focus` can be declared using two `Point` arguments for `position` and `direction`, and a `real` argument for `distance`, in that order.

```

Point pos(0, 5, -10);
Point dir(0, 5, 10);
Focus f(pos, dir, 10);

Point center(2, 0, 3);
Rectangle r(center, 3, 3);

```

<sup>4</sup> I believe this to be true, but I'm not 100% certain.

```
r.draw();
current_picture.output(f);
```

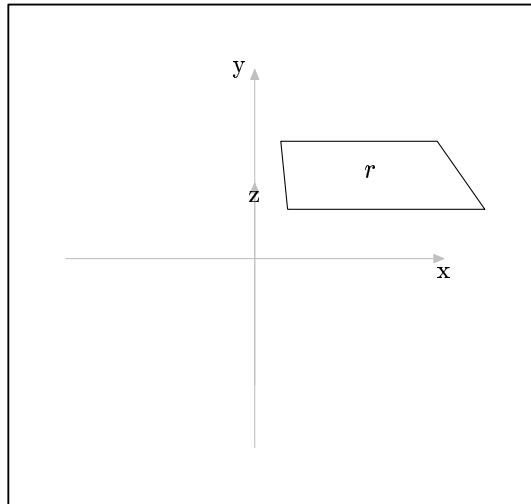

Figure 60.

The “up” direction is calculated by the `Focus` constructor automatically. An optional argument can be used to specify the angle by which to rotate the `Focus` about  $\overrightarrow{PD}$ .

```
Point pos(0, 5, -10);
Point dir(0, 5, 10);
Focus f(pos, dir, 10, 30);
Point center(2, 0, 3);
Rectangle r(center, 3, 3);
r.draw();
current_picture.output(f);
```

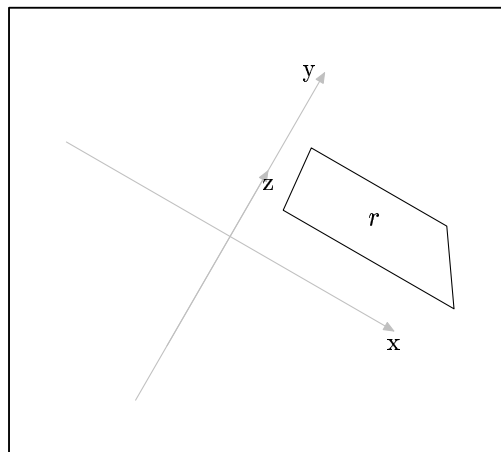

Figure 61.

Alternatively, a `Focus` can be declared using three `real` arguments each for the x, y, and z-coordinates of `position` and `direction`, respectively, followed by the `real` arguments for `distance` and the angle of rotation:

```
Focus f(3, 5, -5, 0, 3, 0, 10, 10);
Point center(2, 0, 3);
```

```

Rectangle r(center, 3, 3);
r.draw();
current_picture.output(f);

```

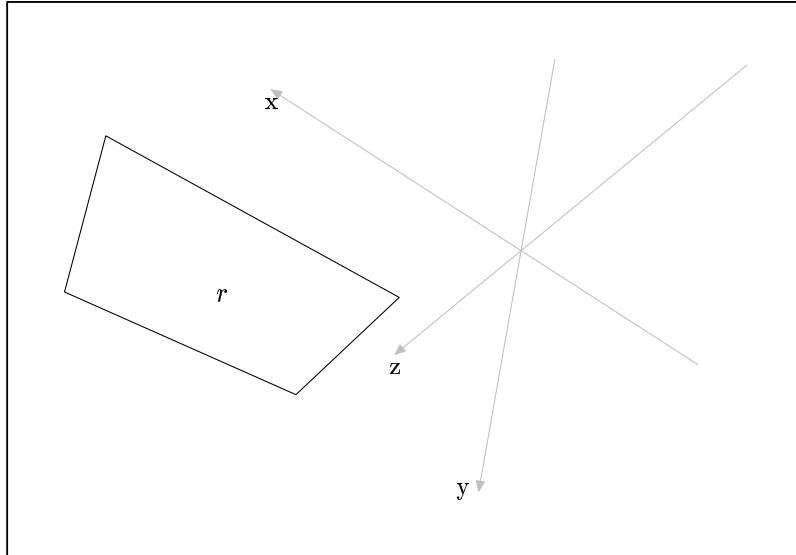

Figure 62.

**Focuses** contain two **Transforms**, **transform** and **persp**. A **Focus** can be located anywhere in 3DLDF's coordinate system. However, performing the perspective projection is more convenient, if **position** and **direction** both lie on one of the major axes, and the plane of projection corresponds to one of the major planes. **transform** is the transformation which would have this affect on the **Focus**, and is calculated by the **Focus** constructor. When a **Picture** is output using that **Focus**, **transform** is applied to all of the **Shapes** on the **Picture**, maintaining the relationship between the **Focus** and the **Shapes**, while making it easier to calculate the projection. The **Focus** need never be transformed by **transform**. The actual perspective transformation is stored in **persp**.

**Focuses** can be moved by using one of the setting functions, which take the same arguments as the constructors. Currently, there are no affine transformation functions for moving **Focuses**, but I plan to add them soon. If 3DLDF is used for making animation, resetting the **Focus** can be used to simulate camera movements:

```

beginfig(1);
Point pos(2, 10, 3);
Point dir(2, -10, 3);
Focus f;
Point center(2, 0, 3);
for (int i = 0; i < 5; ++i)
{
    f.set(pos, dir, 10, (15 * i));
    Rectangle r(center, 3, 3);
    r.draw();
    current_picture.output(f);
    current_picture.clear();
    pos.shift(1, 1, 0);
}

```

```

    dir.rotate(0, 0, 10);
  }
endfig(1);

```

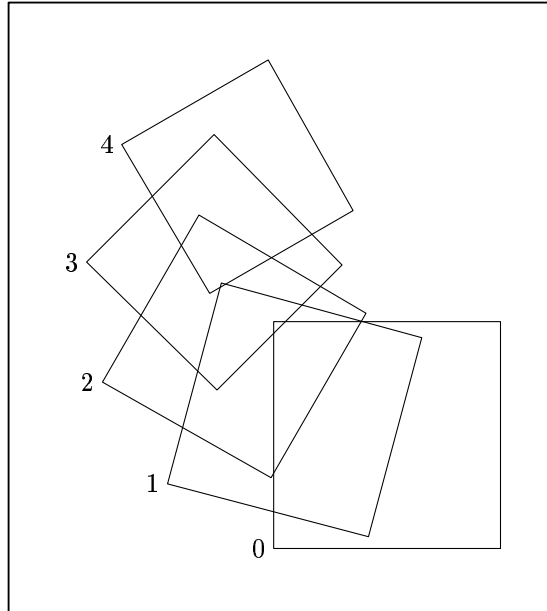

Figure 63.

In Fig. 63, `current_picture` is output 5 times within a single MetaPost figure. Since the file passed to MetaPost is called `'persp.mp'`, the file of Encapsulated PostScript (EPS) code containing Fig. 63 is called `'persp.1'`. To use this technique for making an animation, it's necessary to output the `Picture` into multiple MetaPost figures.

```

Point pos(2, 10, 3);
Point dir(2, -10, 3);
Focus f;
Point center(2, 0, 3);
for (int i = 0; i < 5; ++i)
{
  f.set(pos, dir, 10, (15 * i));
  Rectangle r(center, 3, 3);
  r.draw();
  beginfig(i+1);
  current_picture.output(f);
  endfig();
  current_picture.clear();
  pos.shift(1, 1, 0);
  dir.rotate(0, 0, 10);
}

```

Now, running MetaPost on `'persp.mp'` generates the EPS files `'persp.1'`, `'persp.2'`, `'persp.3'`, `'persp.4'`, and `'persp.5'`, containing the five separate drawings of `r`.

### 9.3 Surface Hiding

In Fig. 64, Circle *c* lies in front of Rectangle *r*. Since *c* is drawn and not filled, *r* is visible behind *c*.

```
default_focus.set(1, 3, -5, 0, 3, 5, 10);  
Point p(0, -2, 5);  
Rectangle r(p, 3, 4, 90);  
r.draw();  
Point q(2, -2, 3);  
Circle c(q, 3, 90);  
c.draw();  
current_picture.output();
```

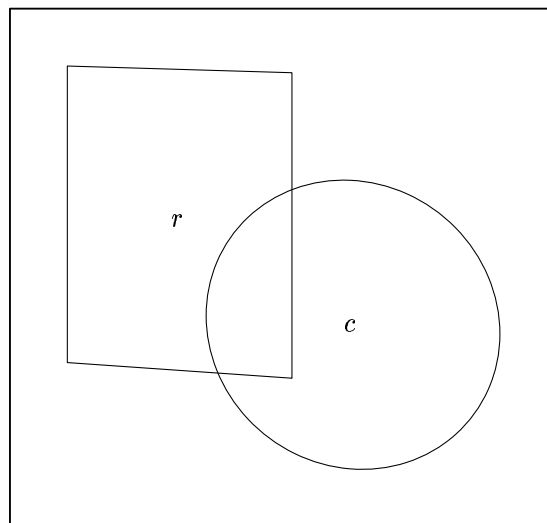

Figure 64.

If instead, *c* is filled or `filldrawn`, only the parts of *r* that are not covered by *c* should be visible:

```
r.draw();  
c.filldraw();
```

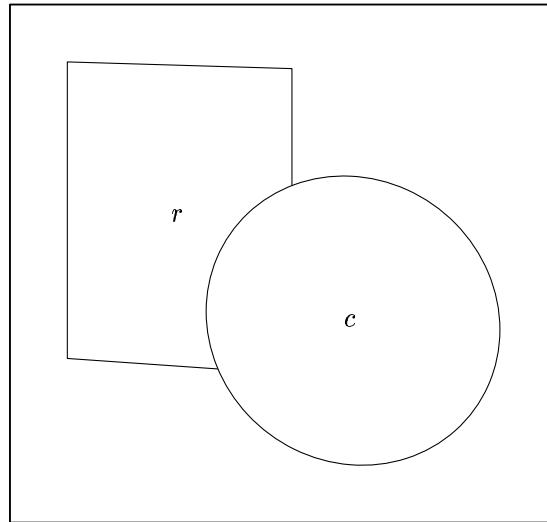

Figure 65.

What parts of `r` are covered depend on the point of view, i.e., the position and direction of the `Focus` used for outputting the `Picture`:

```
default_focus.set(8, 0, -5, 5, 3, 5, 10);
```

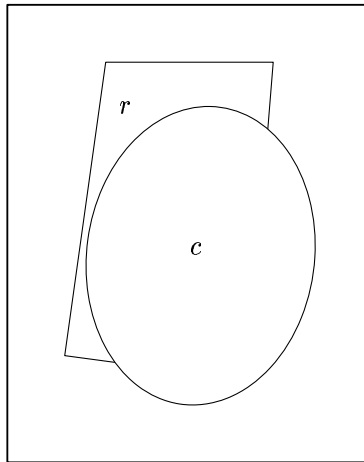

Figure 66.

Determining what objects cover other objects in a program for 3D graphics is called *surface hiding*, and is performed by a *hidden surface algorithm*. 3DLDF currently has a very primitive hidden surface algorithm that only works for the most simple cases.

The hidden surface algorithm used in 3DLDF is a *painter's algorithm*, which means that the objects that are furthest away from the `Focus` are drawn first, followed by the objects that are closer, which may thereby cover them. In order to make this possible, the `Shapes` on a `Picture` must be sorted before they are output. They are sorted according to the `z`-values in the `projective_coordinates` of the `Points` belonging to the `Shape`. This may seem strange, since the projection is two-dimensional and only the `x` and `y`-values from `projective_coordinates` are written to `out_stream`. However, the perspective transformation also produces a `z`-coordinate, which indicates the distance of the `Points` from the `Focus` in the `z`-dimension.

The problem is, that all `Shapes`, except `Points` themselves, consist of multiple `Points`, that may have different `z`-coordinates. 3DLDF currently does not yet have a satisfactory

way of dealing with this situation. In order to try to cope with it, the user can specify four different ways of sorting the **Shapes**: They can be sorted according to the maximum *z*-coordinate, the minimum *z*-coordinate, the mean of the maximum and minimum *z*-coordinate  $(\max + \min)/2$ , and not sorted. In the last case, the **Shapes** are output in the order of the drawing and filling commands in the user code. The *z*-coordinates referred to are those in `projective_coordinates`, and will have been calculated for a particular **Focus**.

The function `Picture::output()` takes a `const unsigned short sort_value` argument that specifies which style of sorting should be used. The namespace `Sorting` contains the following constants which should be used for `sort_value`: `MAX_Z`, `MIN_Z`, `MEAN_Z`, and `NO_SORT`. The default is `MAX_Z`.

3DLDF's primitive hidden surface algorithm *cannot* work for objects that intersect. The following examples demonstrate why not:

```
using namespace Sorting;
using namespace Colors;
using namespace Projections;
default_focus.set(5, 3, -10, 3, 1, 1, 10, 180);
Rectangle r0(origin, 3, 4, 45);
Rectangle r1(origin, 2, 6, -45);
r0.draw();
r1.draw();
current_picture.output(default_focus, PERSP, 1, MAX_Z);
r0.show("r0:");
└─ r0:
fill_draw_value == 0
(-1.5, -1.41421, -1.41421) -- (1.5, -1.41421, -1.41421) --
(1.5, 1.41421, 1.41421) -- (-1.5, 1.41421, 1.41421)
-- cycle;

r0.show("r0:", 'p');
└─ r0:
fill_draw_value == 0
Perspective coordinates.
(-5.05646, -4.59333, -0.040577) -- (-2.10249, -4.86501, -0.102123) --
(-1.18226, -1.33752, 0.156559) -- (-3.51276, -1.2796, 0.193084)
-- cycle;

r1.show("r1:");
└─ r1:
fill_draw_value == 0
(-1, 2.12132, -2.12132) -- (1, 2.12132, -2.12132) --
(1, -2.12132, 2.12132) -- (-1, -2.12132, 2.12132)
-- cycle;

r1.show("r1:", 'p');
└─ r1:
```



```

fill_draw_value == 0
Perspective coordinates.
(-5.09222, -0.995681, -0.133156) -- (-2.98342, -1.03775, -0.181037) --
(-1.39791, -4.05125, 0.208945) -- (-2.87319, -3.93975, 0.230717)
-- cycle;

```

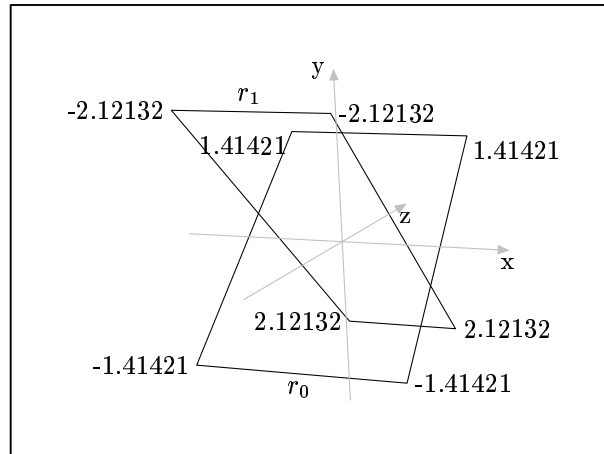

Figure 67.

In Fig. 67, the **Rectangles**  $r_0$  and  $r_1$  intersect along the  $x$ -axis. The  $z$ -values of the **world\_coordinates** of  $r_0$  are  $-1.41421$  and  $1.41421$  (two **Points** each), while those of  $r_1$  are  $2.12132$  and  $-2.12132$ . So  $r_1$  has two **Points** with  $z$ -coordinates greater than the  $z$ -coordinate of any **Point** on  $r_0$ , and two **Points** with  $z$ -coordinates less than the  $z$ -coordinate of any **Point** on  $r_0$ . The **Points** on  $r_0$  and  $r_1$  all have different  $z$ -values in their **projective\_coordinates**, but  $r_1$  still has a **Point** with a  $z$ -coordinate greater than that of any of the **Points** on  $r_0$ , and one with a  $z$ -coordinate less than that of any of the **Points** on  $r_0$ .

In Fig. 68, the **Shapes** on **current\_picture** are sorted according to the maximum  $z$ -values of the **projective\_coordinates** of the **Points** belonging to the **Shapes**.  $r_1$  is filled and drawn first, because it has the **Point** with the positive  $z$ -coordinate of greatest magnitude. When subsequently  $r_0$  is drawn, it covers part of the top of  $r_1$ , which lies in front of  $r_0$ , and should be visible:

```

current_picture.output(default_focus, PERSP, 1, MAX_Z);

```

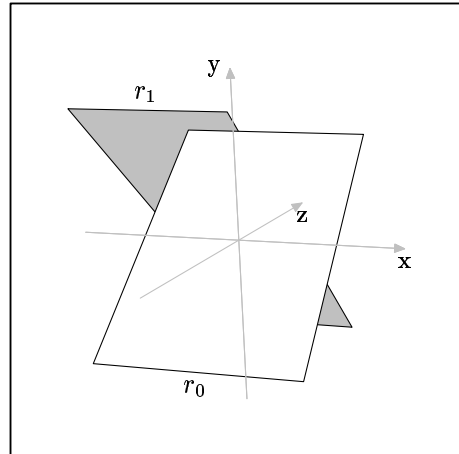

Figure 68.

In Fig. 69, the `Shapes` on `current_picture` are sorted according to the minimum `z`-values of the `projective_coordinates` of the `Points` belonging to the `Shapes`. `r1` is drawn and filled last, because it has the `Point` with the negative `z`-coordinate of greatest magnitude. It thereby covers the bottom part of `r0`, which lies in front of `r1`, and should be visible.

```
current_picture.output(default_focus, PERSP, 1, MIN_Z);
```

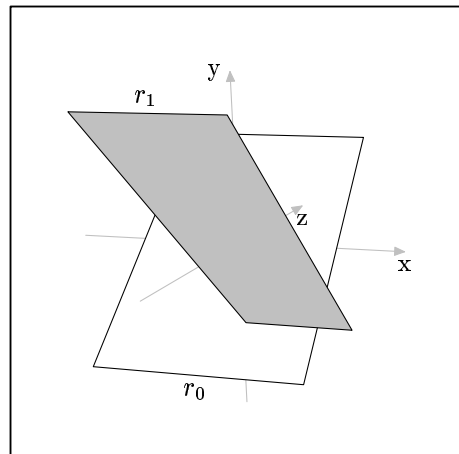

Figure 69.

Neither sorting by the mean `z`-value in the `projective_coordinates`, nor suppressing sorting does any good. In each case, one `Rectangle` is always drawn and filled last, covering parts of the other that lie in front of the first.

3DLDF's hidden surface algorithm will fail wherever objects intersect, not just where one extends past the other in both the positive and negative `z`-directions.

```
Rectangle r(origin, 3, 4, 45);
Circle c(origin, 2, -45);
r.filldraw();
c.filldraw(black, gray);
current_picture.output(default_focus, PERSP, 1, NO_SORT);
```

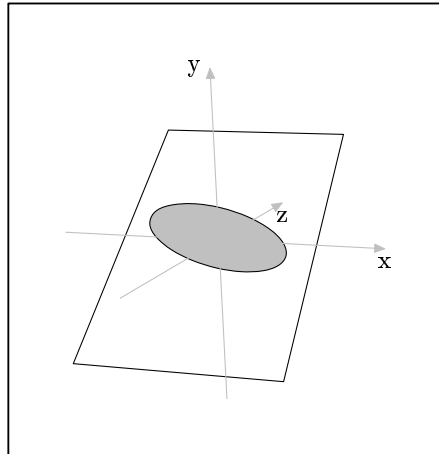

Figure 70.

Even where objects don't intersect, their projections may. In order to handle these cases properly, it is necessary to break up the **Shapes** on a **Picture** into smaller **Shapes**, until there are none that intersect or whose projections intersect. Then, any of the three methods of sorting described above can be used to sort the **Shapes**, and they can be output.

Before this can be done, 3DLDF must be able to find the intersections of all of the different kinds of **Shapes**. If 3DLDF converted solids to polyhedra and curves to sequences of line segments, this would reduce to the problem of finding the intersections of lines and planes, however it does not yet do this.

Even if it did, a fully functional hidden surface algorithm must compare each **Shape** on a **Picture** with every other **Shape**. Therefore, for  $n$  **Shapes**, there will be  $n!/(n-r)!r!$  (possibly time-consuming) comparisons. The following table shows how many comparisons are needed for  $n$  **Shapes** for several values of  $n$ :

Shapes	Comparisons
10	45
100	4950
1000	499,500
10,000	49,995,000
100,000	$4.99995 \times 10^9$

Figure 71.

Clearly, such a hidden surface algorithm would considerably increase run-time.

Currently, all of the **Shapes** on a **Picture** are output, as long as they lie completely within the boundaries passed as arguments to `Picture::output()`. See Section 21.8 [Pictures; Outputting], page 113. It would be more efficient to suppress output for them, if they are completely covered by other objects. This also requires comparisons, and could be implemented together with a fully-functional hidden surface algorithm.

Shadows, reflections, highlights and shading are all effects requiring comparing each **Shape** with every other **Shape**, and could greatly increase run-time.

## 10 Intersections

There are no functions for finding the intersection points of two (or more) arbitrary `Paths`. This is impossible, so long as 3DLDF outputs MetaPost code. 3DLDF only “knows” about the `Points` on a `Path`; it doesn’t actually generate the curve or other figure that passes through the `Points`, and consequently doesn’t “know” how it does this.

In addition, an arbitrary `Path` can contain connectors. In 3DLDF, the connectors are merely `strings` and are written verbatim to the output file, however, in MetaPost they influence the form of a `Path`.

3DLDF can, however, find the intersection points of some *non-arbitrary* `Paths`. So far, it can find the intersection point of the following combinations of `Paths`:

1. Two linear `Paths`, i.e., `Paths` for which `Path::is_linear()` returns `true` (see Section 26.15 [Path Reference; Querying], page 193). In addition, the static `Point` member function `Point::intersection_points()` can be called with four `Point` arguments. The first and second arguments are treated as the end points of one line, and the third and fourth arguments as the end points of the other.
2. A line and a `Polygon`. Currently, `Reg_Polygon` and `Rectangle` are the only classes derived from `Polygon`.
3. Two `Polygons`.
4. A line and a Regular Closed Plane Curve (`Reg_C1_Plane_Curve`, see Section 30.3 [Regular Closed Plane Curve Reference; Intersections], page 216). Currently, `Ellipse` and `Circle` are the only classes derived from `Reg_C1_Plane_Curve`.
5. Two `Ellipses`. Since a `Circle` is also an `Ellipse`, one or both of the `Ellipses` may be a `Circle`. See Section 31.9 [Ellipse Reference; Intersections], page 229.

Adding more functions for finding the intersections of various geometric figures is one of my main priorities with respect to extending 3DLDF.

There are currently no special functions for finding the intersection points of a line and a `Circle` or two `Circles`. Since the class `Circle` is derived from class `Ellipse`, `Circle::intersection_points()` resolves to `Ellipse::intersection_points()`, which, in turn, calls `Reg_C1_Plane_Curve::intersection_points()`. This does the trick, but it’s much easier to find the intersections for `Circles` that it is for `Ellipses`. In particular, the intersections of two coplanar `Circles` can be found algebraically, whereas I’ve had to implement a numerical solution for the case of two coplanar `Ellipses` with different centers and/or axis orientation. It may also be worthwhile to write a specialization for finding the intersection points of a `Circle` and an `Ellipse`.

The theory of intersections is a fascinating and non-trivial branch of mathematics.<sup>1</sup> As I learn more about it, I plan to define more `classes` to represent various curves (two-dimensional ones to start with) and functions for finding their intersection points.

---

<sup>1</sup> The books on computer graphics and the fairly elementary mathematics books that I own or have referred to don’t go into intersections very deeply. One that does is Fischer, Gerd. *Ebene Algebraische Kurven*, which is a bit over my head.

## 11 Installing and Running 3DLDF

### 11.1 Installing 3DLDF

3DLDF is available for downloading from <http://ftp.gnu.org/gnu/3dldf>. The official 3DLDF website is <http://www.gnu.org/software/3dldf>. The “tarball”, i.e., the compressed archive file ‘3DLDF-1.1.5.1.tar.gz’ unpacks into a directory called ‘/3DLDF-1.1.5.1/’.

On a typical Unix-like system, entering the following commands at the command line in a shell will unpack the 3DLDF distribution. Please note that the form of the commands may differ on your system.

```
gunzip 3DLDF-1.1.5.1.tar.gz
tar xpvf 3DLDF-1.1.5.1.tar
```

The ‘p’ option to `tar` ensures that the files will have the same permissions as when they were packed.

The directory ‘3DLDF-1.1.5.1/’ contains a `configure` script, which should be called from the command line in the shell, using the absolute path of ‘3DLDF-1.1.5.1/’ as the prefix argument. For example, if the path is ‘/usr/local/mydir/3DLDF-1.1.5.1/’, `configure` should be invoked as follows:

```
cd 3DLDF-1.1.5.1
configure --prefix=/usr/local/mydir/3DLDF-1.1.5.1/
```

`configure` generates a ‘Makefile’ from the ‘Makefile.in’ in ‘3DLDF-1.1.5.1/’, and in each of the subdirectories ‘3DLDF-1.1.5.1/CWEB’, ‘3DLDF-1.1.5.1/DOC’, and ‘3DLDF-1.1.5.1/DOC/TEXINFO’. Now, `make install` causes the 3DLDF to be built. The executable is called ‘3dldf’.

See the files ‘README’ and ‘INSTALL’ in the 3DLDF distribution for more information.

#### 11.1.1 Template Functions

3DLDF 1.1.5 is the first release that contains *template functions*, namely `template <class C> C* create_new()`, which is defined in `creatnew.web`, and `template <class Real> Real get_second_largest()`, which is defined in `gs1tmpl.web`. See Chapter 14 [Dynamic Allocation of Shapes], page 83, and Section 15.3 [Get Second Largest Real], page 86.

In order for template functions to be instantiated correctly, their *definitions* must be available in each compilation unit where specializations are declared or used. For non-template functions, it suffices for their *declarations* to be available, and their definitions are found at link-time. For this reason, the definitions of `create_new()` and `get_second_largest()` are in their own CWEB files, and are written to their own header files. The latter are included in the other CWEB files that need them.

In addition, ‘AM\_CXXFLAGS = -frepo’ has been added to the file ‘Makefile.am’ in ‘3DLDF-1.1.5/CWEB/’, so that the C++ compiler is called using the ‘-frepo’ option. The manual *Using and Porting the GNU Compiler Collection* explains this as follows:

“Compile your template-using code with ‘`-frepo`’. The compiler will generate files with the extension ‘`.rpo`’ listing all of the template instantiations used in the corresponding object files which could be instantiated there; the link wrapper, ‘`collect2`’, will then update the ‘`.rpo`’ files to tell the compiler where to place those instantiations and rebuild any affected object files. The link-time overhead is negligible after the first pass, as the compiler will continue to place the instantiations in the same files.”<sup>1</sup>

The first time the executable ‘`3ldf`’ is built, the files that use the template functions are recompiled one or more times, and the linker is also called several times. This doesn’t happen anymore, once the ‘`.rpo`’ files exist.

Template instantiation differs from compiler to compiler, so using template functions will tend to make 3DLDF less portable. I am no longer able to compile it on the DECalpha Personal Workstation I had been using with the DEC C++ compiler. See Section 1.6 [Ports], page 8, for more information.

## 11.2 Running 3DLDF

To use 3DLDF, call `make run` from the command line in the shell. The working directory should be ‘`3DLDF-1.1.5.1/`’ or ‘`3DLDF-1.1.5.1/CWEB/`’. Either will work, but the latter may be more convenient, because this is the location of the CWEB,  $\text{\TeX}$  and MetaPost files that you’ll be editing. Alternatively, call `ldfr`, which is merely a shell script that calls `make run`. This takes care of running `3ldf`, MetaPost,  $\text{\TeX}$ , and `dvips`, producing a PostScript file containing your drawings. You can display the latter on your terminal using Ghostview or some other PostScript viewer, print it out, and whatever else you like to do with PostScript files.

However, you can also perform the actions performed by `make run` by hand, by writing your own shell scripts, by defining Emacs-Lisp commands, or in other ways. Even if you choose to use `make run`, it’s important to understand what it does. The following explains how to do this by hand.

The CWEB source files for 3DLDF are in the subdirectory ‘`3DLDF-1.1.5.1/CWEB/`’. They must be `ctangled`, and the resulting C++ files must be compiled and linked, in order to create the executable file ‘`3ldf`’. The C++ files and header files generated by `ctangle`, the object files generated by the compiler, and the executable ‘`3ldf`’ all reside in ‘`3DLDF-1.1.5.1/CWEB/`’. Therefore, the latter must be your working directory.

Since 3DLDF has no input routine as yet, as explained in Section 1.5.2 [No Input Routine], page 8, it is necessary to add C++ code to the function `main()` in ‘`main.web`’, and/or in a separate function in another file. In the latter case, the function containing the user code must be invoked in `main()`. Look for the line “Your code here!” in ‘`main.web`’.

This is an example of what you could write in `main()`. Feel free to make it more complicated, if you wish.

```
beginfig(1);
default_focus.set(2, 3, -10, 2, 3, 10, 20);
Rectangle R(origin, 5, 3);
```

---

<sup>1</sup> Stallman, Richard M. *Using and Porting the GNU Compiler Collection*, p. 285.

```

Circle C(origin, 3, 90);
C.half(180).filldraw(black, light_gray);
R.filldraw();
C.half().filldraw(black, light_gray);
Point p = C.get_point(4);
p.shift(0, -.5 * p.get_y());
p.label("$C$", "");
Point q = R.get_mid_point(0);
q.shift(0, 0, -.5 * q.get_z());
q.label("$R$", "");
current_picture.output(default_focus, PERSP, 1, NO_SORT);
endfig(1);

```

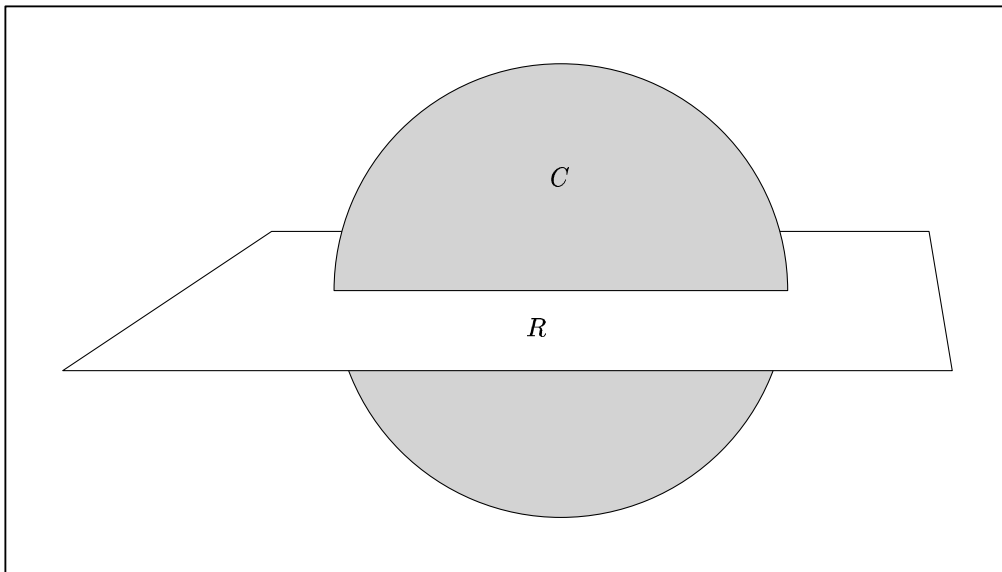

Figure 72.

1. Save 'main.web', and any other CWEB files you've changed. Since these files have changed, they must be `ctangled`, and the resulting C++ files must be recompiled. If you've changed any files other than 'main.web', `ctangle` will also generate a header file for each of these files. If a header file differs from the version that existed before `ctangle` was run, all of the C++ files that depend on it must be recompiled. Then '3dlldf' must be relinked. To do this, call `make 3dlldf` from the command line.

If you've made any errors in typing your code, the compiler should have issued error messages, so go back into the appropriate CWEB file and correct your errors. Then call `make 3dlldf` again.

2. Call `CWEB/3dlldf` at the command line. It writes a file of MetaPost code called '3DLDFput.mp'.
3. Run MetaPost on the file '3DLDFmp.mp', which inputs '3DLDFput.mp'.

```
mpost 3DLDFput
```

The result is an Encapsulated PostScript file '3DLDFput.<integer>' for each figure in your drawing.

4. The file ‘3DLDFtex.tex’ should contain code for including the ‘3DLDFput.’<integer> files. This is an example taken from the ‘3DLDFtex.tex’ included in the distribution. You may change it to suit your purposes.

```

\ vbox to \ vsize{\ vskip 2cm
\ line{\ hskip 2cm Figure 1.\ hss}%
\ vfil
\ line{\ hskip 2cm\ epsffile{3DLDFmp.1}\ hss}%
\ vss}

```

5. Run `TEX` on ‘3DLDFtex.tex’ to produce the DVI file, ‘3DLDFtex.dvi’.

```

tex 3DLDFtex

```
6. Run `dvips` on the DVI file to produce the PostScript file, ‘3DLDFtex.ps’.

```

dvips -o 3DLDFtex.ps 3DLDFtex

```
7. ‘3DLDFtex.ps’ can be viewed using Ghostview, it can be printed using `lpr` (on a Unix-like system), you can convert it to PDF with `ps2pdf`, or to some other format using the appropriate program.

I sincerely hope that it worked. If it didn’t, ask your local computer wizard for help.

On the computer I’m using, I found that `special` arguments for setting `landscape` and `papersize` in `TEX` files for DIN A3 landscape didn’t work. Ghostview cut off the right sides of the drawings. Nor did it work to call `dvips -t landscape -t a3`. This caused an error message which said that `landscape` would be ignored. When I called `dvips` with the ‘-t landscape’ option alone, it worked, and Ghostview showed the entire drawing.

Another problem was Adobe Acrobat. It would display the entire DIN A3 page, but not always in landscape format. I was unable to find a way of rotating the pages in Acrobat. I finally found out, that if I included even a single letter of text in a label, Acrobat would display the document correctly.

### 11.2.1 Converting EPS Files

ImageMagick (<http://www.imagemagick.org>) is a “collection of tools and libraries” for image manipulation. It provides a ‘`convert`’ utility which can convert images from one format to another. It can convert structured PostScript (PS) to to Portable Network Graphics (PNG) (<http://www.libpng.org/pub/png/index.html>), but *not* EPS (Encapsulated PostScript) to PNG. Nor can it convert EPS to structured PostScript.

It is possible to have MetaPost generate structured PostScript directly by including the command ‘`prologues:=1;`’ at the beginning of the MetaPost input. However, this “generally doesn’t work when you use `TEX` fonts.”<sup>2</sup> This is a significant problem if your labels contain math mode material, and you haven’t already taken steps to ensure that appropriate fonts will be used in the PS output.

In the following, I describe the *only way* I’ve found to convert an EPS image to PNG format while still using `TEX` fonts. There may be other and better ways of doing this, but I haven’t found them.

---

<sup>2</sup> Hobby, *A User’s Manual for MetaPost*, pp. 21–22.



1. Assume the EPS image is in the file ‘3DLDFmp.1’. Include the EPS image in a  $\TeX$  file which looks like this:

```

\advance\voffset by -1in
\advance\hoffset by -1in
\nopagenumbers
\input epsf
\epsfverbosetrue
\def\epsfsize#1#2{#1}
\setbox0=\vbox{\epsffile{3DLDFmp.1}}
\vsizer=\ht0
\hsizer=\wd0
\special{papersize=\the\wd0,\the\ht0}
\box0
\bye

```

**Do not** name this file ‘3DLDFmp.1.tex’! While this worked fine for me on a DECalpha Personal Workstation running under Tru64 Unix 5.1, with  $\TeX$ , Version 3.1415 (C version 6.1), and **dvipsk** 5.58f, it failed on a PC Pentium II XEON under Linux 2.4, with  $\TeX$ , Version 3.14159 (Web2C 7.4.5), and **dvips(k)** 5.92b, kpathsea version 3.4.5, with the following error message:

“No BoundingBox comment found in file examples.1; using defaults”

The resulting PS image had the wrong size and the the graphic was positioned improperly.

Apparently, it confuses the EPSF macros when the name of an included image is the same as ‘ $\jobname$ ’. So, for this example, let’s call it ‘3DLDFmp.1\_.tex’.

You don’t really need to call the macro ‘ $\epsfverbosetrue$ ’. If you do, it will print the measurements of the bounding box and other information to standard output.<sup>3</sup>

2. Run ‘`tex 3DLDFmp.1_.tex`’.
3. Run ‘`dvips -o 3DLDF.1.ps 3DLDFmp.1_.dvi`’.
4. Run ‘`convert 3DLDF.1.ps 3DLDFmp.1.png`’.

ImageMagick supplies a ‘`display`’ utility, which can be used to display the PNG image:

```
display 3DLDFmp.1.png
```

It can be included in an HTML document as follows:

```

.png’ to a CD-R (Compact Disk, Recordable), when ‘*number*’ had more than one digit.

---

<sup>3</sup> Rokicki, *Dvips: A DVI-to-PostScript Translator*, p. 24.

### 11.2.1.1 Emacs-Lisp Functions

The file ‘3DLDF-1.1.5.1/CWEB/cnepspng.el’ contains definitions of two Emacs-Lisp functions that can be used to convert Encapsulated PostScript (EPS) files to structured PostScript (PS) and Portable Network Graphics (PNG) files.

**convert-eps** *filename do-not-delete-files* [Emacs-Lisp function]

Converts an EPS image file to the PS and PNG formats.

If called interactively, **convert-eps** prompts for the filename, including the extension, of an EPS image file. It follows the procedure described above in Section 11.2.1 [Converting EPS Files], page 76, to create ‘*filename.ps*’ and ‘*filename.png*’.

If *do-not-delete-files* is `nil`, the ‘.tex’, ‘.dvi’, and ‘.log’ files will be deleted. This is the case when **convert-eps** is called interactively with no prefix argument. If **convert-eps** is called interactively with a prefix argument, or non-interactively with a non-`nil` *do-not-delete-files* argument, these files will not be deleted.

**convert-eps-loop** *arg start end* [Emacs-Lisp function]

Converts a set of EPS image files to the PS and PNG formats. The files must all have the same filename, and the extensions must form a range of positive integers. For example, **convert-eps-loop** can be used to convert the files ‘3DLDFmp.1’, ‘3DLDFmp.2’, and ‘3DLDFmp.3’ to ‘3DLDFmp.1.ps’, ‘3DLDFmp.2.ps’, and ‘3DLDFmp.3.ps’ on the one hand, and ‘3DLDFmp.1.png’, ‘3DLDFmp.2.png’, ‘3DLDFmp.3.png’ on the other.

If **convert-eps-loop** is called interactively, it prompts for *filename with no extension* and the starting and ending numbers of the range.

For all  $i \in \mathbb{Z}$  and  $start \leq i \leq end$ , **convert-eps-loop** checks whether a file named ‘*filename.i*’ exists. If it does, it calls **convert-eps**, passing ‘*filename.i*’ as the latter’s *filename* argument.

*do-not-delete-files* is also passed to **convert-eps**. If it’s `nil`, the ‘.tex’, ‘.dvi’, and ‘.log’ files will be deleted. This is the case when **convert-eps-loop** is called interactively with no prefix argument. If **convert-eps-loop** is called interactively with a prefix argument, or non-interactively with a non-`nil` *do-not-delete-files* argument, these files will not be deleted.

## 11.2.2 Command Line Arguments

`3dldf` can be called with the following *command line arguments*.

- `--help` Prints information about the valid command line options to standard output and exits with return value 0.
- `--silent` Suppresses some output to standard output and standard error when `3dldf` is run
- `--verbose` Causes status information to be printed to standard output when `3dldf` is run.
- `--version` Prints the version number of 3DLDF to standard output and exits with return value 0.

Currently, `3ldf` can only handle long options. `-` cannot be substituted for `--`. However, the names of the options themselves can be abbreviated, as long as the abbreviation is unambiguous. For example, `3ldf --h` and `3ldf --verb` are valid, but `3ldf --ver` is not.

## 12 Typedefs and Utility Structures

3DLDF defines a number of data types for various reasons, e.g., for the sake of convenience, for use in conditional compilation, or as return values of functions. Some of these data types can be defined using `typedef`, while others are defined as `structs`.

The typedefs and utility structures described in this chapter are found in ‘`pspg1b.web`’. Others, that contain objects of types defined in 3DLDF, are described in subsequent chapters.

**real** [typedef]

Synonymous either with `float` or `double`, depending on the values of the preprocessor variables `LDF_REAL_FLOAT` and `LDF_REAL_DOUBLE`. The meaning of `real` is determined by means of conditional compilation. If `real` is `float`, 3DLDF will require less memory than if `real` is `double`, but its calculations will be less precise. `real` is “typedefed” to `float` by default.

**real\_pair first second** [typedef]

Synonymous with `pair<real, real>`.

**real\_triple first second third** [struct]

All three data elements of `real_triple` are `reals`. It also has two constructors, described below. There are no other member functions.

`void real_triple (void)` [Constructor]

`void real_triple (real a, real b, real c)` [Constructor]

The constructor taking no arguments sets `first`, `second`, and `third` to 0. The constructor taking three `real` arguments sets `first` to `a`, `second` to `b`, and `third` to `c`.

**Matrix** [typedef]

A `Matrix` is a  $4 \times 4$  array of `real`, e.g., `Matrix M; ≡ real M[4][4]`. It is used in `class Transform` for storing transformation matrices. See Chapter 4 [Transforms], page 18, and See Chapter 19 [Transform Reference], page 95, for more information.

**real\_short first second** [typedef]

Synonymous with `pair<real, signed short>`. It is the return type of `Plane::get_distance()`.

**bool\_pair first second** [typedef]

Synonymous with `pair<bool, bool>`.

**bool\_real first second** [typedef]

Synonymous with `pair<bool, real>`.

## 13 Global Constants and Variables

The global constants and variables described in this chapter are found in ‘`pspglb.web`’. Others, of types defined in 3DLDF, are described in subsequent chapters.

**bool `ldf_real_float`** [Constants]  
**bool `ldf_real_double`**

Set to 0 or 1 to match the values of the preprocessor macros `LDF_REAL_FLOAT` and `LDF_REAL_DOUBLE`. The latter are used for conditional compilation and determine whether `real` is “typedefed” to `float` or `double`, i.e., whether `real` is made to be a synonym of `float` or `double` using `typedef`.

`ldf_real_float` and `ldf_real_double` can be used to control conditional expressions in non-conditionally compiled code.

**real `PI`** [Constant]

The value of `PI` ( $\pi$ ) is calculated as  $4.0 \times \arctan(1.0)$ . I believe that a preprocessor macro “`PI`” was available when I compiled 3DLDF using the DEC C++ compiler, and that it wasn’t, when I used GNU CC under Linux, but I’m no longer sure.

**valarray <real> `null_coordinates`** [Variable]

Contains four elements, all 0. Used for resetting the sets of coordinates belonging to `Points`, but only when the DEC C++ compiler is used. This doesn’t work when GCC is used.

**real `INVALID_REAL`** [Constant]

Actually, `INVALID_REAL` is the largest possible `real` value (i.e., `float` or `double`) on a given machine. So, from the point of view of the compiler, it’s not invalid at all. However, 3DLDF uses it to indicate failure of some kind. For example, the return value of a function returning `real` can be compared with `INVALID_REAL` to check whether the function succeeded or failed.

An alternative approach would be to use the exception handling facilities of C++. I do use these, but only in a couple of places, so far.

**real\_pair `INVALID_REAL_PAIR`** [Constant]

`first` and `second` are both `INVALID_REAL`.

**real `INVALID_REAL_SHORT`** [Constant]

`first` is `INVALID_REAL` and `second` is 0.

**real `MAX_REAL`** [Variable]

The largest `real` value permitted in the the elements of `Transforms` and the coordinates of `Points`. It is the second largest `real` value (i.e., `float` or `double`) on a given machine (`INVALID_REAL` is the largest).

`MAX_REAL` is a variable, but it should be used like a constant. In other words, users should never reset its value. It can’t be declared `const` because its value must be calculated using function calls, which can’t be done before the entry point of the program, i.e., `main()`. Therefore, the value of `MAX_REAL` is calculated at the beginning of `main()`.

**real MAX\_REAL\_SQRT** [Variable]

The square root of `MAX_REAL`.

`MAX_REAL_SQRT` is a variable, but it should be used like a constant. In other words, users should never reset its value. It can't be declared `const` because its value is calculated using the `sqrt()` function, which can't be done before the entry point of the program, i.e., `main()`. Therefore, the value of `MAX_REAL_SQRT` is set after `MAX_REAL` is calculated, at the beginning of `main()`.

`MAX_REAL_SQRT` is used in `Point::magnitude()` (see Section 22.15 [Vector Operations], page 135). The magnitude of a `Point` is found by using the formula  $\sqrt{x^2 + y^2 + z^2}$ .  $x$ ,  $y$ , and  $z$  are all tested against `MAX_REAL_SQRT` to ensure that  $x^2$ ,  $y^2$ , and  $z^2$  will all be less than or equal to `MAX_REAL` before trying to calculate them. Metafont implements an operation called *Pythagorean addition*, notated as “++” which can be used to calculate distances without first squaring and then taking square roots:<sup>1</sup>  $a++b \equiv \sqrt{a^2 + b^2}$  and  $a++b++c \equiv \sqrt{a^2 + b^2 + c^2}$ . This makes it possible to calculate distances for greater values of  $a$ ,  $b$ , and  $c$ , that would otherwise cause floating point errors. Metafont also implements the inverse operation *Pythagorean subtraction*, notated as “+-+”:  $a+-+b \equiv \sqrt{a^2 - b^2}$ . Unfortunately, 3DLDF implements neither Pythagorean addition nor subtraction as yet, but it's on my list of “things to do”.

---

<sup>1</sup> Knuth, Donald E. *The Metafont book*, p. 66.

## 14 Dynamic Allocation of Shapes

```
template <class C> C* create_new (const C* arg)           [Template function]
```

```
template <class C> C* create_new (const C& arg)         [Template function]
```

These functions dynamically allocate an object derived from `Shape` on the free store, returning a pointer to the type of the `Shape` and setting `on_free_store` to `true`.

If a non-zero pointer or a reference is passed to `create_new()`, the new object will be a copy of `arg`.

It is not possible to instantiate more than one specialization of `create_new()` that takes no argument, because calls to these functions would be ambiguous. If the new object is not meant to be a copy of an existing one, '0' must be passed to `create_new()` as its argument.

`create_new` is called like this:

```
Point* p = create_new<Point>(0);
p->show("p:");
└ *p: (0, 0, 0)
```

```
Color c(.3, .5, .25);
Color* d = create_new<Color>(c);
d->show("d:");
└
*d:
name ==
use_name == 0
red_part == 0.3
green_part == 0.5
blue_part == 0.25
```

```
Point a0(3, 2.5, 6);
Point a1(10, 11, 14);
Path q(a0, a1);
Path* r = create_new<Path>(&q);
r->show("r:");
└
*r:
points.size() == 2
connectors.size() == 1
(3, 2.5, 6) -- (10, 11, 14);
```

Specializations of this template function are currently declared for `Color`, `Point`, `Path`, `Reg_Polygon`, `Rectangle`, `Ellipse`, `Circle`, `Solid`, and `Cuboid`.

## 15 System Information

The functions described in this chapter are all declared in the namespace `System`. They are for finding out information about the system on which 3DLDF is being run. They are declared and defined in `'pspg1b.web'`, except for the template function `get_second_largest()`, which is declared and defined in `'gs1tmpl1.web'`.

There are two reasons for this. The first is that template definitions must be available in the compilation units where specializations are instantiated. I therefore write the template definition of `get_second_largest()` to `'gs1tmpl1.h'`, so it can be included by the CWEB files that need it, currently `'main.web'` only. If I wrote it to `'pspg1b.h'`, it would be included by all of the CWEB files except for `'loader.web'`, causing unnecessarily bloated object code.

The other reason is because of the way way 3DLDF is built using Automake and `make`. I originally tried to define `get_second_largest()` in `'pspg1b.web'` and wrote the definition to `'gs1tmpl1.cc'`, which is no problem with CWEB. However, I was unable to express the dependencies among the CWEB, C++, and object files in such a way that 3DLDF was built properly.

Therefore all template functions will be put into files either by themselves, or in small groups.

### 15.1 Endianness

`signed short get_endianness ([const bool verbose = false])` [Function]

Returns the following values:

- 0           if the processor is little-endian.
- 1           if the processor is big-endian.
- 1          if the endianness cannot be determined.

It is called by `is_little_endian()` and `is_big_endian()`.

If `verbose` is `true`, messages are printed to standard output.

This function has been adapted from Harbison, Samuel P., and Guy L. Steele Jr. *C, A Reference Manual*, pp. 163–164. This book has the clearest explanation of endianness that I've found so far.

This is the C++ code:

```
signed short
System::get_endianness(const bool verbose)
{
    union {
        long Long;
        char Char[sizeof(long)];
    } u;
    u.Long = 1;
    if (u.Char[0] == 1)
    {
        if (verbose)
```



```

        cout << "Processor is little-endian."
             << endl << endl << flush;
    return 0;
}
else if (u.Char[sizeof(long) - 1] == 1)
{
    if (verbose)
        cout << "Processor is big-endian."
             << endl << endl << flush;
    return 1;
}
else
{
    cerr << "ERROR! In System::get_endianness():\n"
         << "Can't determine endianness. Returning -1"
         << endl << endl << flush;
    return -1;
}
}

```

**bool is\_big\_endian** ([const bool *verbose* = false]) [Function]  
 Returns **true** if the processor is big-endian, otherwise **false**. If *verbose* is **true**, messages are printed to standard output.

**bool is\_little\_endian** ([const bool *verbose* = false]) [Function]  
 Returns **true** if the processor is little-endian, otherwise **false**. If *verbose* is **true**, messages are printed to standard output.

## 15.2 Register Width

**unsigned short get\_register\_width** (void) [Function]  
 Returns the register width of the CPU of the system on which 3DLDF is being run. This will normally be either 32 or 64 bits.

This is the C++ code:

```
return (sizeof(void*) * CHAR_BIT);
```

This assumes that an address will be the same size as the processor's registers, and that `CHAR_BIT` will be the number of bits in a byte. These are reasonable assumptions that apply to all architectures I know about.

This function is called by `is_32_bit()` and `is_64_bit()`.

**bool is\_32\_bit** (void) [Function]  
 Returns **true** if the CPU of the system on which 3DLDF is being run has a register width of 32 bits, otherwise **false**.

**bool is\_64\_bit** (void) [Function]  
 Returns **true** if the CPU of the system on which 3DLDF is being run has a register width of 64 bits, otherwise **false**.

### 15.3 Get Second Largest Real

```
template <class Real> Real get_second_largest (Real MAX_VAL, [bool verbose = false]) [Template function]
```

```
float get_second_largest (float, bool) [Template specialization]
```

```
double get_second_largest (double, bool) [Template specialization]
```

`get_second_largest` returns the second largest floating point number of the type specified the template parameter *Real*. If *verbose* is `true`, messages are printed to standard output.

This function is used for setting the value of `MAX_REAL`. See Chapter 13 [Global Constants and Variables], page 81.

`get_second_largest` depends on there being an unsigned integer type with the same length as *Real*. This should always be the case for `float` and `double`, but may not be `long double`.

`MAX_VAL` should be the largest number of type *Real* on a given architecture. The GNU C++ compiler GCC 3.3 does not currently supply the `numeric_limits` template, so it is necessary to pass one of the macros `FLT_MAX` or `DBL_MAX` explicitly, depending on which specialization you use<sup>1</sup>. When and if GCC supplies the `numeric_limits` template, I will eliminate the `MAX_REAL` argument.

---

<sup>1</sup> If your system supplies an unsigned integer type with the same length as `long double`, then you can instantiate `get_second_largest<long double>()` and call `'get_second_largest<long double>(LDBL_MAX)'`. However, I doubt that this amount of precision would be worthwhile. If it ever were required, 3DLDF would have to be changed in other ways, too. In particular, it would have to use more precise trigonometric functions for rotations. See Section 1.5.1 [Accuracy], page 7.

## 16 Color Reference

Class `Color` is defined in `'colors.web'`.

### 16.1 Data Members

`string name` [Variable]  
The name of the `Color`.

`bool use_name` [Variable]  
If `true`, `name` is written to `out_stream` when the `Color` is used for drawing or filling. Otherwise, the RGB (red-green-blue) values are written to `out_stream`.

`bool on_free_store` [Variable]  
`true`, if the `Color` has been created by `create_new<Color>()`, which allocates memory for the `Color` on the free store. Otherwise `false`. `Colors` should only ever be dynamically allocated by using `create_new<Color>()`. See Section 16.2 [Color Reference;;Constructors and Setting Functions], page 87.

`real red_part` [Variable]

`real green_part` [Variable]

`real blue_part` [Variable]

The RGB (red-green-blue) values of the `Color`. A `real` value  $r$  is valid for these variables if and only if  $0 \leq r \leq 1$ .

### 16.2 Constructors and Setting Functions

`void Color (void)` [Default constructor]  
Creates a `Color` and initializes its `red_part`, `green_part`, and `blue_part` to 0. `use_name` and `on_free_store` are set to `false`.

`void Color (const Color& c, [const string n = "", [const bool u = true]])` [Copy constructor]  
Creates a `Color` and makes it a copy of `c`. If `n` is not the empty string and `u` is `true`, `use_name` is set to `true`. Otherwise, its set to `false`.

`void Color (const string n, const unsigned short r, const unsigned short g, const unsigned short b, [const bool u = true])` [Constructor]  
Creates a `Color` with name `n`. Its `red_part`, `green_part`, and `blue_part` are set to  $r/255.0$ ,  $g/255.0$ , and  $b/255.0$ , respectively. `use_name` is set to `u`.

`void set (const string n, const unsigned short r, const unsigned short g, const unsigned short b, [const bool u = false])` [Setting function]  
Corresponds to the constructor above, except that `u` is `false` by default.

`void Color (const real r, const real g, const real b)` [Constructor]  
Creates an unnamed `Color` using the `real` values `r`, `g`, and `b` for its `red_part`, `green_part`, and `blue_part`, respectively.

`void set (const real r, const real g, const real b)` [Setting function]  
 Corresponds to the constructor above.

`Color* create_new<Color> (const Color* c)` [Template specializations]

`Color* create_new<Color> (const Color& c)`

Pseudo-constructors for dynamic allocation of Colors. They create a `Color` on the free store and allocate memory for it using `new(Color)`. They return a pointer to the new `Color`.

If `c` is a non-zero pointer or a reference, the new `Color` will be a copy of `c`. If the new object is not meant to be a copy of an existing one, '0' must be passed to `create_new<Color>()` as its argument. See Chapter 14 [Dynamic Allocation of Shapes], page 83, for more information.

This function is used in the drawing and filling functions for `Path` and `Solid`. `Point::drawdot()` should be changed to use it too, but I haven't gotten around to doing this yet.

## 16.3 Operators

`void operator= (const Color& c)` [Assignment operator]  
 Sets `name` to the empty string, `use_name` to `false`, and `red_part`, `green_part`, and `blue_part` to `c.red_part`, `c.green_part`, and `c.blue_part`, respectively.

`bool operator== (const Color& c)` [const operator]  
 Equality operator. Returns `true`, if the `red_parts`, `green_parts`, and `blue_parts` of `*this` and `c` are equal, otherwise `false`. The names and `use_names` are not compared.

`bool operator!= (const Color& c)` [const operator]  
 Inequality operator. Returns `false`, if the `red_parts`, `green_parts`, and `blue_parts` of `*this` and `c` are equal, otherwise `true`. The names and `use_names` are not compared.

`ostream& operator<< (ostream& o, const Color& c)` [Non-member function]  
 Output operator. Writes the MetaPost code for the `Color` to `out_stream` when a `Picture` is output. This occurs when the `Color` has been used as an argument to drawing or filling functions.

If `use_name` is `true`, `name` is written to `out_stream`. Otherwise, “(`red_part`, `green_part`, `blue_part`)” is written to `out_stream`.

## 16.4 Modifying

`void set_name (const string s)` [Function]  
 Sets `name` to `s`. `use_name` is not reset.

`void set_use_name (const bool b)` [Function]  
 Sets `use_name` to `b`.

**void modify** (const real *r*, [const real *g* = 0, [const real *b* = 0]]) [Function]  
 Adds *r*, *g*, and *b* to `red_part`, `green_part`, and `blue_part`, respectively. Following the addition, if `red_part`, `green_part`, and/or `blue_part` is greater than 1, it is reduced to 1. If it is less than 0, it is increased to 0.

**void set\_red\_part** (const real *q*) [Function]

**void set\_green\_part** (const real *q*) [Function]

**void set\_blue\_part** (const real *q*) [Function]

Let *p* stand for `red_part`, `green_part`, or `blue_part`, depending upon which function is used. If  $0 \leq q \leq 1$ , *p* is set to *q*. If  $q < 0$ , *p* is set to 0. If  $q > 1$ , *p* is set to 1.

## 16.5 Showing

**void show** ([string *text* = ""]) [const function]

Prints information about the `Color` to standard output. If *text* is not the empty string, prints *text* on a line of its own. Otherwise, it prints "Color:". Then it prints name, `use_name`, `red_part`, `green_part`, and `blue_part`.

## 16.6 Querying

**bool is\_on\_free\_store** (void) [const function]

Returns `on_free_store`. This will only be true, if the `Color` was created by `create_new<Color>()`. See Section 16.2 [Color Reference; Constructors and Setting Functions], page 87.

**real get\_red\_part** ([bool *decimal* = false]) [Inline const function]

**real get\_green\_part** ([bool *decimal* = false]) [Inline const function]

**real get\_blue\_part** ([bool *decimal* = false]) [Inline const function]

These functions return the `red_part`, `green_part`, or `blue_part` of the `Color`, respectively. If *decimal* is `false` (the default), the actual real value of the "part" is returned. Otherwise, the corresponding whole number *n* such that  $0 \leq n \leq 255$  is returned.

**bool get\_use\_name** (void) [const function]

Returns `use_name`.

**string get\_name** (void) [Inline const function]

Returns `name`.

## 16.7 Defining and Initializing Colors

**void define\_color\_mp** () [const function]

Writes MetaPost code to `out_stream`, in order to define objects of type `color` within MetaPost, and set their `redparts`, `greenparts`, and `blueparts`.

**void initialize\_colors** (void) [Static function]

Calls `define_color_mp()` (described above) for the `Colors` that are defined in namespace `Colors` (see Section 16.8 [Namespace Colors], page 90).

## 16.8 Namespace Colors.

|                                       |            |
|---------------------------------------|------------|
| <code>const Color red</code>          | [Constant] |
| <code>const Color green</code>        | [Constant] |
| <code>const Color blue</code>         | [Constant] |
| <code>const Color cyan</code>         | [Constant] |
| <code>const Color yellow</code>       | [Constant] |
| <code>const Color magenta</code>      | [Constant] |
| <code>const Color orange_red</code>   | [Constant] |
| <code>const Color violet_red</code>   | [Constant] |
| <code>const Color pink</code>         | [Constant] |
| <code>const Color green_yellow</code> | [Constant] |
| <code>const Color orange</code>       | [Constant] |
| <code>const Color violet</code>       | [Constant] |
| <code>const Color purple</code>       | [Constant] |
| <code>const Color blue_violet</code>  | [Constant] |
| <code>const Color yellow_green</code> | [Constant] |
| <code>const Color black</code>        | [Constant] |
| <code>const Color white</code>        | [Constant] |
| <code>const Color gray</code>         | [Constant] |
| <code>const Color light_gray</code>   | [Constant] |

These constant Colors can be used in drawing and filling commands.

|                                                                        |            |
|------------------------------------------------------------------------|------------|
| <code>const Color default_background</code>                            | [Constant] |
| The default background color. Equal to <code>white</code> per default. |            |
| <code>const Color* background_color</code>                             | [Pointer]  |
| Points to <code>default_background</code> by default.                  |            |
| <code>const Color* default_color</code>                                | [Pointer]  |
| Points to <code>black</code> by default.                               |            |
| <code>const Color* help_color</code>                                   | [Pointer]  |
| Points to <code>green</code> by default.                               |            |

The following vectors of pointers to Color can be used in the drawing and filling functions for Solid (see Section 34.13 [Solid Reference; Drawing and Filling], page 254).

|                                                                        |          |
|------------------------------------------------------------------------|----------|
| <code>const vector &lt;const Color*&gt; default_color_vector</code>    | [Vector] |
| Contains one pointer, namely <code>default_color</code> .              |          |
| <code>const vector &lt;const Color*&gt; help_color_vector</code>       | [Vector] |
| Contains one pointer, namely <code>help_color</code> .                 |          |
| <code>const vector &lt;const Color*&gt; background_color_vector</code> | [Vector] |
| Contains one pointer, namely <code>background_color</code> .           |          |

## 17 Input and Output

### 17.1 Global Variables

**ifstream in\_stream** [Variable]  
 Intended for inputting files of input code. However, 3DLDF does not currently have a routine for reading input code. `in_stream` is currently attached to the file `'ldfinput.ldf'` by `initialize_io()` (see Section 17.2 [I/O Functions], page 91). `in_stream` is read in character-by-character in `main()`, however this serves no useful purpose as yet.

**ofstream out\_stream** [Variable]  
 Used for writing the file of MetaPost code, which is 3DLDF's output. Currently attached to the file `'subpersp.mp'` by `initialize_io()` (see Section 17.2 [I/O Functions], page 91).

**ofstream tex\_stream** [Variable]  
 T<sub>E</sub>X code can be written to a file through `tex_stream`, if desired. 3DLDF makes no use of it itself. Currently attached to `'subpersp.tex'` by `initialize_io()` (see Section 17.2 [I/O Functions], page 91).

### 17.2 I/O Functions

**void initialize\_io** (`string in_stream_name, string out_stream_name, string tex_stream_name, char* program_name`) [Function]  
 Opens files with names specified by the first three arguments, and attaches them to the file streams `in_stream`, `out_stream`, and `tex_stream`, respectively. Comments are written at the beginning of the files, containing their names, a datestamp, and the name of the program used to generate them.

**void write\_footers** (`void`) [Function]  
 Writes code at the end of the files attached to `in_stream`, `out_stream`, and `tex_stream`, before the streams are closed. Currently, they write comments containing local variable lists for use in Emacs.

**void beginfig** (`unsigned short i`) [Inline function]  
 Writes `"beginfig(i)"` to `out_stream`.

**void endfig** (`[unsigned short i = 0]`) [Inline function]  
 Writes `"endfig()"` to `out_stream`. The argument `i` is "syntactic sugar"; it's ignored by `endfig()`, but may help the user keep track of what figure is being ended.

## 18 Shape Reference

Class `Shape` is defined in ‘`shapes.web`’.

`Shape` is an *abstract class*, which means that all of its member functions are pure virtual functions, and that it’s only used as a base class, i.e., no objects of type `Shape` may be declared.

All of the “drawable” types in 3DLDF, `Point`, `Path`, `Ellipse`, etc., are derived from `Shape`.

Deriving all of the drawable types from `Shape` makes it possible to handle objects of different types in the same way. This is especially important in the `Picture` functions, where objects of various types (but all derived from `Shape`) are accessed through pointers to `Shape`. See Chapter 21 [Picture Reference], page 110.

### 18.1 Data Members

```
signed short DRAWDOT                                [Protected static constants]
signed short DRAW
signed short FILL
signed short FILLDRAW
signed short UNDRAWDOT
signed short UNDRAW
signed short UNFILL
signed short UNFILLDRAW
```

Values used in the `output()` functions of the classes derived from `Shape`. For example, in `Path`, if the data member `fill_draw_value = DRAW`, then the MetaPost command `draw` is written to `out_stream` when that `Path` is output.

### 18.2 Operators

```
Transform operator*= (const Transform& t)            [Pure virtual function]
```

### 18.3 Copying

```
Shape* get_copy (void)                               [const pure virtual function]
```

Copies an object, allocating memory on the free store for the copy, and returns a pointer to `Shape` for accessing the copy.

Used in the drawing and filling functions for copying the `Shape`, and putting a pointer to the copy onto the `vector<Shape*> shapes` of the `Picture`.

### 18.4 Modifying

```
bool set_on_free_store (bool b = true)              [Pure virtual function]
```

Sets the data member `on_free_store` to `b`. All classes derived from `Shape` must therefore also have a data member `on_free_store`.



This function is used in the template function `create_new<type>`. See Chapter 14 [Dynamic Allocation of Shapes], page 83, for more information.

## 18.5 Affine Transformations

Transform `rotate` (`const real x`, `const real y`, `const real z`) [Pure virtual functions]

Transform `scale` (`real x`, `real y`, `real z`)

Transform `shear` (`real xy`, `real xz`, `real yx`, `real yz`, `real zx`, `real zy`)

Transform `shift` (`real x`, `real y`, `real z`)

Transform `rotate` (`const Point& p0`, `const Point& p1`, `const real r`)

See Section 22.12 [Point Reference; Affine Transformations], page 129.

## 18.6 Applying Transformations

`void apply_transform` (`void`) [Pure virtual function]

Applies the `Transform` stored in the `transform` data member of the `Points` belonging to the `Shape` to their `world_coordinates`. The `transforms` are subsequently reset to the identity `Transform`.

## 18.7 Clearing

`void clear` (`void`) [Pure virtual function]

The precise definition of this function will depend on the nature of the derived class. In general, it will call the destructor on dynamically allocated objects belonging to the `Shape`, and deallocate the memory they occupied.

## 18.8 Querying

`bool is_on_free_store` (`void`) [const pure virtual function]

Returns `true` if the object was allocated on the free store, otherwise `false`.

## 18.9 Showing

`void show` ([`string text = ""`, [`char coords = 'w'`, [const pure virtual function]  
[`const bool do_persp = true`, [`const bool do_apply = true`, [`Focus* f = 0`,  
[`const unsigned short proj = 0`, [`const real factor = 1`]]]]]])

Prints information about an object to standard output. See the descriptions of `show()` for the classes derived from `Shape` for more information.

## 18.10 Outputting

**void output** (void) [Pure virtual function]

Called by `Picture::output()` for writing MetaPost code to `out_stream` for a `Shape` pointed to by a pointer on the `vector<Shape*> shapes` belonging to the `Picture`. Such a `Shape` will have been created by a drawing or filling function.

**vector<Shape\*> extract** (const `Focus& f`, const [Pure virtual function]  
                           unsigned short `proj`, real `factor`)

Called in `Picture::output()`. It determines whether a `Shape` can be output. If it can, and an `output()` function for the type of the `Shape` exists, a `vector<Shape*>` containing a pointer to the `Shape` is returned.

On the other hand, it is possible to define a type derived from `Shape`, without an `output()` function of its own, and not derived from a type that has one. It may then consist of one or more objects of types that do have `output()` functions. In this case, the `vector<Shape*>` returned by `extract()` will contain pointers to all of these subsidiary `Shapes`, and `Picture::output()` will treat them as independent objects. In particular, if any one of them cannot be projected using the arguments passed to `Picture::output()`, this will have no effect on whether the others are outputted or not.

Currently, there are no `Shapes` without an `output()` function, either belonging to the class, or inherited. However, it's useful to be able to define `Shapes` in this way, so that they can be tested without having to define an `output()` function first.

**bool set\_extremes** (void) [Pure virtual function]

Sets the values of `projective_extremes` for the `Shape`. This is needed in `Picture::output()` for determining the order in which objects are output.

**real get\_minimum\_z** (void) [const pure virtual functions]

**real get\_maximum\_z** (void)

**real get\_mean\_z** (void)

These functions return the minimum, maximum, and mean z-value respectively of the projected `Points` belonging to the `Shape`, i.e., from `projective_extremes`. The values for the `Shapes` on the `Picture` are used for determining the order in which they are output

**const valarray<real> get\_extremes** (void) [const pure virtual function]

Returns `projective_extremes`.

**void suppress\_output** (void) [Pure virtual function]

Sets `do_output` to `false`. This function is called in `Picture::output()`, if a `Shape` on a `Picture` cannot be output using the arguments passed to `Picture::output()`.

**void unsuppress\_output** (void) [Pure virtual function]

Sets `do_output` to `true`. Called in `Picture::output()` after `output()` is called on the `Shapes`. This way, output of `Shapes` that couldn't be output when `Picture::output()` was called with a particular set of arguments won't necessarily be suppressed when `Picture::output()` is called again with different arguments.

## 19 Transform Reference

Class `Transform` is defined in ‘`transfor.web`’. `Point` is a friend of `Transform`.

### 19.1 Data Members

**Matrix** `matrix` [Private variable]  
A  $4 \times 4$  matrix of `real` representing the actual transformation matrix.

### 19.2 Global Variables and Constants

**Transform** `user_transform` [Variable]  
Currently has no function. It is intended to be used for transforming the coordinates of `Points` between the world coordinate system (WCS) and a user coordinate system (UCS), when routines for managing user coordinate systems are implemented.

`const Transform` **INVALID\_TRANSFORM** [Constant]  
Every member of `matrix` in `INVALID_TRANSFORM` is equal to `INVALID_REAL`.

`const Transform` **IDENTITY\_TRANSFORM** [Constant]  
Homogeneous coordinates and `Transforms` are unchanged by multiplication with `IDENTITY_TRANSFORM`. `matrix` is an identity matrix:

$$\begin{pmatrix} 1 & 0 & 0 & 0 \\ 0 & 1 & 0 & 0 \\ 0 & 0 & 1 & 0 \\ 0 & 0 & 0 & 1 \end{pmatrix}$$

See Chapter 4 [Transforms], page 18.

### 19.3 Constructors

`void Transform` (`void`) [Default constructor]  
Creates a `Transform` containing the identity matrix.

`void Transform` (`real r`) [Constructor]  
Creates a `Transform` and sets all of the elements of `matrix` to `r`. Currently, this constructor is never used, but who knows? Maybe someday it will be useful for something.

`void Transform` (`real r0_0`, `real r0_1`, `real r2`, `real r0_2`, `real` [Constructor]  
`r0_3`, `real r1_0`, `real r1_1`, `real r1_2`, `real r1_3`, `real r2_0`, `real r2_1`,  
`real r2_2`, `real r2_3`, `real r3_0`, `real r3_1`, `real r3_2`, `real r3_3`)  
Each of the sixteen `real` arguments is assigned to the corresponding element of `matrix`: `matrix[0][0] = r0_0`, `matrix[0][1] = r0_1`, etc. Useful for specifying a transformation matrix completely.

## 19.4 Operators

**Transform operator=** (const Transform& t) [Assignment operator]

Sets *\*this* to *t* and returns *t*. Returning *\*this* would, of course, have exactly the same effect.

**real operator\*=** (real r) [Operator]

Multiplication with assignment by a scalar. This operator multiplies each element *E* of **matrix** by the scalar *r*. The return value is **r**. This makes it possible to chain invocations of this function: For  $a_x, b_x, c_x, \dots, p_x \in \mathbb{R}, x \in \mathbb{N}$

```

Transform T0(a_0, b_0, c_0, d_0,
             e_0, f_0, g_0, h_0,
             i_0, j_0, k_0, l_0,
             m_0, n_0, o_0, p_0);
Transform T1(a_1, b_1, c_1, d_1,
             e_1, f_1, g_1, h_1,
             i_1, j_1, k_1, l_1,
             m_1, n_1, o_1, p_1);
Transform T2(a_2, b_2, c_2, d_2,
             e_2, f_2, g_2, h_2,
             i_2, j_2, k_2, l_2,
             m_2, n_2, o_2, p_2);

real r = 5;

```

Let  $M_0$ ,  $M_1$ , and  $M_2$  stand for `T0.matrix`, `T1.matrix`, and `T2.matrix` respectively:

$$M_0 = \begin{pmatrix} a_0 & b_0 & c_0 & d_0 \\ e_0 & f_0 & g_0 & h_0 \\ i_0 & j_0 & k_0 & l_0 \\ m_0 & n_0 & o_0 & p_0 \end{pmatrix} \quad M_1 = \begin{pmatrix} a_1 & b_1 & c_1 & d_1 \\ e_1 & f_1 & g_1 & h_1 \\ i_1 & j_1 & k_1 & l_1 \\ m_1 & n_1 & o_1 & p_1 \end{pmatrix}$$

$$M_2 = \begin{pmatrix} a_2 & b_2 & c_2 & d_2 \\ e_2 & f_2 & g_2 & h_2 \\ i_2 & j_2 & k_2 & l_2 \\ m_2 & n_2 & o_2 & p_2 \end{pmatrix}$$

```
T0 *= T1 *= T2 *= r;
```

Now,

$$M_0 = \begin{pmatrix} 5a_0 & 5b_0 & 5c_0 & 5d_0 \\ 5e_0 & 5f_0 & 5g_0 & 5h_0 \\ 5i_0 & 5j_0 & 5k_0 & 5l_0 \\ 5m_0 & 5n_0 & 5o_0 & 5p_0 \end{pmatrix} \quad M_1 = \begin{pmatrix} 5a_1 & 5b_1 & 5c_1 & 5d_1 \\ 5e_1 & 5f_1 & 5g_1 & 5h_1 \\ 5i_1 & 5j_1 & 5k_1 & 5l_1 \\ 5m_1 & 5n_1 & 5o_1 & 5p_1 \end{pmatrix}$$

$$M_2 = \begin{pmatrix} 5a_2 & 5b_2 & 5c_2 & 5d_2 \\ 5e_2 & 5f_2 & 5g_2 & 5h_2 \\ 5i_2 & 5j_2 & 5k_2 & 5l_2 \\ 5m_2 & 5n_2 & 5o_2 & 5p_2 \end{pmatrix}$$

This function is not currently used anywhere, but it may turn out to be useful for something.

**Transform operator\*** (const real r) [const operator]

Multiplication of a **Transform** by a scalar without assignment. The return value is a **Transform** *A*. If **this.matrix** has elements  $E_T$ , then **A.matrix** has elements  $E_A$  such that  $E_A = r \times E_T$  for all  $E$ .

**Transform operator\*=** (const Transform& t) [Operator]

Performs matrix multiplication on **matrix** and **t.matrix**. The result is assigned to **matrix**. *t* is returned, *not \*this!* This makes it possible to chain invocations of this function:

```
Transform a;
a.shift(1, 1, 1);
Transform b;
b.rotate(0, 90);
Transform c;
c.shear(5, 4);
Transform d;
d.scale(3, 4, 5);
```

Let  $a_m$ ,  $b_m$ , and  $c_m$  stand for **a.matrix**, **b.matrix**, **c.matrix**, and **d.matrix** respectively:

$$a_m = \begin{pmatrix} 1 & 0 & 0 & 0 \\ 0 & 1 & 0 & 0 \\ 0 & 0 & 1 & 0 \\ 1 & 1 & 1 & 1 \end{pmatrix} \quad b_m = \begin{pmatrix} 0.5 & 0.5 & 0.707 & 0 \\ 0.146 & 0.854 & -0.5 & 0 \\ -0.854 & 0.146 & 0.5 & 0 \\ 0 & 0 & 0 & 1 \end{pmatrix}$$

$$c_m = \begin{pmatrix} 1 & 12 & 14 & 0 \\ 10 & 1 & 15 & 0 \\ 11 & 13 & 1 & 0 \\ 0 & 0 & 0 & 1 \end{pmatrix} \quad d_m = \begin{pmatrix} 3 & 0 & 0 & 0 \\ 0 & 4 & 0 & 0 \\ 0 & 0 & 5 & 0 \\ 0 & 0 & 0 & 1 \end{pmatrix}$$

```
a *= b *= c *= d;
```

**a**, **b**, and **c** are transformed by **d**, which remains unchanged.

Now,

$$a_m = \begin{pmatrix} 3 & 0 & 0 & 0 \\ 0 & 4 & 0 & 0 \\ 0 & 0 & 5 & 0 \\ 3 & 4 & 5 & 1 \end{pmatrix} \quad b_m = \begin{pmatrix} 1.5 & 2 & 3.54 & 0 \\ -0.439 & 3.41 & -2.5 & 0 \\ -2.56 & 0.586 & 2.5 & 0 \\ 0 & 0 & 0 & 1 \end{pmatrix}$$

$$c_m = \begin{pmatrix} 3 & 48 & 70 & 0 \\ 30 & 4 & 75 & 0 \\ 33 & 52 & 5 & 0 \\ 0 & 0 & 0 & 1 \end{pmatrix}$$

$d_m$  is unchanged.

**Transform operator\*** (`const Transform t`) [const operator]  
 Multiplication of a `Transform` by another `Transform` without assignment. The return value is a `Transform` whose `matrix` contains values that are the result of the matrix multiplication of `matrix` and `t.matrix`.

## 19.5 Matrix Inversion

**Transform inverse** (`void`) [const function]  
**Transform inverse** (`[bool assign = false]`) [Function]

Returns a `TransformT` with a `T.matrix` that is the inverse of `matrix`. If `assign`  $\equiv$  `true`, then `matrix` is set to its inverse.

In the `const` version, `matrix` remains unchanged. The second should only ever be called with `true` as its `assign` argument. If you're tempted call `inverse(false)`, you might as well just leave out the argument, which issues a warning message, and calls the `const` version.

## 19.6 Setting Values

**void set\_element** (`const unsigned short row, const unsigned short col, real r`) [Function]

Sets the element of `matrix` indicated by the arguments to `r`.

```
Transform t;
t.set_element(0, 2, -3.45569);
t.show("t:");
┌ t:
  1      0   -3.46      0
  0      1      0      0
  0      0      1      0
  0      0      0      1
```

## 19.7 Querying

**bool is\_identity** (`void`) [Function]

Returns `true` if `*this` is the identity `Transform`, otherwise `false`. This function has both a `const` and a non-`const` version. In the non-`const` version, `clean()` is called on `*this` before comparing the elements of `matrix` with 1 (for the main diagonal) and 0 (for the other elements). In the `const` version, `*this` is copied, `clean()` is called on the copy, and the elements of the copy's `matrix` are compared with 0 and 1.

**real get\_element** (`const unsigned short row, const unsigned short col`) [const function]

Returns the value stored in the element of `matrix` indicated by the arguments.

```
Transform t;
t.shift(1, 2, 3);
```

```

t.scale(2.5, -1.2, 4);
t.rotate(30, 15, 60);
t.show("t:");
+ t:
    1.21    2.09    0.647    0
    0.822  -0.654    0.58    0
    -2.18    0.224    3.35    0
    -3.69    1.45    11.8    1
cout << t.get_element(2, 1);
+ 0.224

```

## 19.8 Returning Information

`real epsilon` (void) [Static function]

Returns the positive `real` value of smallest magnitude  $\epsilon$  which an element of a `Transform` should contain. An element of a `Transform` may also contain  $-\epsilon$ .

The value  $\epsilon$  is used for in the function `clean()` (see Section 19.13 [Transform Reference; Cleaning], page 106). It will also be used for comparing `Transforms`, when I've added the equality operator `Transform::operator==()`.

`epsilon()` returns different values, depending on whether `real` is `float` or `double`: If `real` is `float` (the default), `epsilon()` returns 0.00001. If `real` is `double`, it returns 0.000000001.

**Please note:** I haven't tested whether 0.000000001 is a good value yet, so users should be aware of this if they set `real` to `double`!<sup>1</sup> The way to test this is to transform two different `Transforms`  $t_1$  and  $t_2$  using different rotations in such a way that the end result should be the same for both `Transforms`. Let  $\epsilon$  stand for the value returned by `epsilon()`. If for all sets of corresponding elements  $E_1$  and  $E_2$  of  $t_1$  and  $t_2$ ,  $||E_1| - |E_2|| \leq \epsilon$ , then  $\epsilon$  is a good value. It will be easier to test this when I've added `Transform::operator==()`.

Rotation causes a significant loss of precision to due to the use of the `sin()` and `cos()` functions. Therefore, neither `Transform::epsilon()` nor `Point::epsilon()` (see Section 22.10 [Point Reference; Returning Information], page 128) can be as small as I'd like them to be. If they are two small, operations that test for equality of `Transforms` and `Points` will return `false` for objects that should be equal.

## 19.9 Showing

`void show` ([string `text` = ""]) [const function]

If the optional argument `text` is used, and is not the empty `string` (""), `text` is printed on a line of its own to the standard output first. Otherwise, "`Transform`:" is printed on a line of its own to the standard output. Then, the elements of `matrix` are printed to standard output.

---

<sup>1</sup> For that matter, I haven't really tested whether 0.00001 is a good value when `real` is `float`.

```

Transform t;
t.show("t:");
┌ t:
    1      0      0      0
    0      1      0      0
    0      0      1      0
    0      0      0      1
t.scale(1, 2, 3);
t.shift(1, 1, 1);
t.rotate(90, 90, 90);
t.show("t:");
┌ t:
    0      0      1      0
    0      2      0      0
   -3      0      0      0
   -1      1      1      1

```

## 19.10 Affine Transformations

The affine transformation functions use their arguments to create a new `Transform t` (local to the function) representing the appropriate transformation. Then, `*this` is multiplied by `t` and `t` is returned. Returning `t` instead of `*this` makes it possible to put the affine transformation function at the end of a chain of invocations of `Transform::operator*=( )`:

```

Transform t0, t1, t2, t3;
...
t0 *= t1 *= t2 *= t3.scale(2, 3.5, 9);

```

`t0`, `t1`, and `t2` are all multiplied by the `Transform` with

$$\text{matrix} = \begin{pmatrix} 2 & 0 & 0 & 0 \\ 0 & 3.5 & 0 & 0 \\ 0 & 0 & 9 & 0 \\ 0 & 0 & 0 & 1 \end{pmatrix}$$

representing the scaling operation, *not* `t3`, which may represent a combination of transformations.

**Transform scale** (real `x`, [real `y = 1`, [real `z = 1`]]) [Function]

Creates a `Transform t` representing the scaling operation locally, multiplies `*this` by `t`, and returns `t`. A `Transform` representing scaling only, when applied to a `Point p`, will cause its x-coordinate to be multiplied by `x`, its y-coordinate to be multiplied by `y`, and its z-coordinate to be multiplied by `z`.

```

Transform t;
t.scale(x, y, z);
⇒ t.matrix = \begin{pmatrix} x & 0 & 0 & 0 \\ 0 & y & 0 & 0 \\ 0 & 0 & z & 0 \\ 0 & 0 & 0 & 1 \end{pmatrix}

```



```

Transform t;
t.scale(12.5, 20, 1.3);
t.show("t:");
┌ t:
  12.5    0    0    0
    0    20    0    0
    0    0    1.3  0
    0    0    0    1

```

Transform **shear** (real *xy*, [real *xz* = 0, [real *yx* = 0, [real *yz* = 0, [real *zx* = 0, [real *zy* = 0]]]]]) [Function]

Creates a Transform *t* representing the shearing operation locally, multiplies *\*this* by *t*, and returns *t*.

When applied to a Point, shearing causes each coordinate to be modified according to the values of the other coordinates and the arguments to **shear**:

```

Point p(x,y,z);
Transform t;
t.shear(a, b, c, d, e, f);
p *= t;

⇒ p = ((x + ay + bz), (y + cx + dz), (z + ex + fy))

```

```

Transform t;
t.shear(2, 3, 4, 5, 6, 7);
t.show("t:");
┌ t:
  1    4    6    0
  2    1    7    0
  3    5    1    0
  0    0    0    1

```

Transform **shift** (real *x*, [real *y* = 0, [real *z* = 0]]) [Function]

Transform **shift** (const Point& *p*) [Function]

These functions create a Transform *t* representing the shifting operation locally, multiplies *\*this* by *t*, and returns *t*.

The version with the argument const Point& *p* passes the updated *x*, *y*, and *z*-coordinates of *p* (from *world\_coordinates*) to the version with three real arguments.

When a Transform representing a single shifting operation only is applied to a Point, the *x*, *y*, and *z* arguments are added to the corresponding coordinates of the Point:

```

Point p(x,y,z);
Transform t;
t.shift(a, b, c);
p *= t;

```

$$\Rightarrow p = (x + a, y + b, z + c)$$

Transform **shift\_times** (real *x*, [real *y* = 1, [real *z* = 1]]) [Function]

Multiplies the corresponding elements of **matrix** by the **real** arguments, i.e., **matrix**[3][0] is multiplied by *x*, **matrix**[3][1] is multiplied by *y*, and **matrix**[3][2] is multiplied by *z*. Returns **\*this**.

Ordinary shifting is additive, so a special function is needed to multiply the elements of **matrix** responsible for shifting. The effect of **shift\_times()** is to modify a **Transform** representing a shifting operation such that the direction of the shift is maintained, while changing the distance.

If the **Transform** represents other operations in addition to shifting, e.g., scaling and/or shearing, the effect of **shift\_times()** may be unpredictable.<sup>2</sup>

```
Transform t;
t.shift(1, 2, 3);
```

$$\Rightarrow \mathbf{t.matrix} = \begin{pmatrix} 1 & 0 & 0 & 0 \\ 0 & 1 & 0 & 0 \\ 0 & 0 & 1 & 0 \\ 1 & 2 & 3 & 1 \end{pmatrix}$$

```
t.shift_times(2, 2, 2);
```

$$\Rightarrow \mathbf{t.matrix} = \begin{pmatrix} 1 & 0 & 0 & 0 \\ 0 & 1 & 0 & 0 \\ 0 & 0 & 1 & 0 \\ 2 & 4 & 6 & 1 \end{pmatrix}$$

```
Rectangle r[4];
r[0].set(origin, 1, 1, 90);
r[3] = r[2] = r[1] = r[0];
Transform t;
t.shift(1.5, 1.5);
r[0] *= t;
r[0].draw();
t.shift_times(1.5, 1.5);
r[1] *= t;
r[1].draw();
t.shift_times(1.5, 1.5);
r[2] *= t;
r[2].draw();
t.shift_times(1.5, 1.5);
r[3] *= t;
r[3].draw();
```

---

<sup>2</sup> For a person, not in the sense of the program behaving unpredictably.

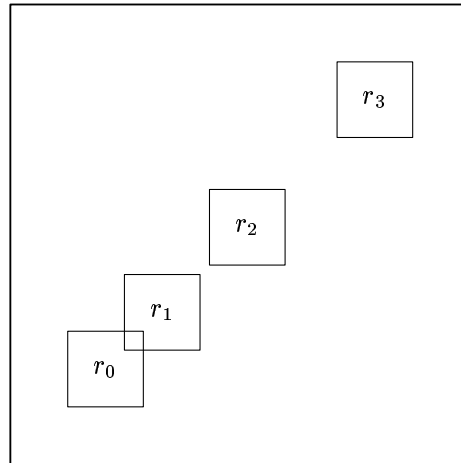

Figure 73.

```
Cuboid c(origin, 1, 1, 1);  
c.draw();  
Transform t;  
t.rotate(30, 30, 30);  
t.shift(1, 0, 1);  
c *= t;  
c.draw();  
t.shift_times(1.5, 0, 1.5);  
c *= t;  
c.draw();  
t.shift_times(1.5, 0, 1.5);  
c *= t;  
c.draw();  
t.shift_times(1.5, 0, 1.5);  
c *= t;  
c.draw();  
t.shift_times(1.5, 0, 1.5);  
c *= t;  
c.draw();
```

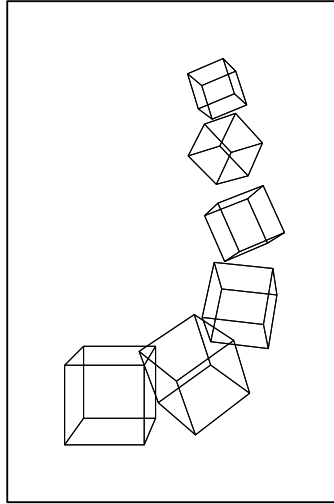

Figure 74.

**Transform rotate** (real *x*, [real *y* = 0, [real *z* = 0]]) [Function]  
 Rotation around the main axes. Creates a Transform *t* representing the rotation, multiplies *\*this* by *t*, and returns *t*.

**Transform rotate** (Point *p0*, Point *p1*, [const real *angle* = 180]) [Function]  
 Rotation around an arbitrary axis. The Point arguments represent the end points of the axis, and *angle* is the angle of rotation. Since 180° rotation is needed so often, 180 is the default for *angle*.

**Transform rotate** (const Path& *p*, [const real *angle* = 180]) [Function]  
 Rotation around an arbitrary axis. Path argument. The Path *p* must be linear, i.e., *p.is\_linear()* must return true. See Section 26.15 [Path Reference; Querying], page 193.

## 19.11 Alignment with an Axis

**Transform align\_with\_axis** (Point *p0*, Point *p1*, [char *axis* = 'z']) [Function]  
 Returns the Transform that would align the line through *p0* and *p1* with the major axis denoted by the *axis* argument. The default is the z-axis. This function is used in the functions that find intersections.

```
Point P0(1, 1, 1);
Point P1(2, 3, 4);
P0.draw(P1);
P0.dotlabel("$P_0$");
P1.dotlabel("$P_1$");
Transform t;
t.align_with_axis(P0, P1, 'z');
P0 *= P1 *= t;
t.show("t:");
┌ t:
  0.949  -0.169  0.267   0
    0    0.845  0.535   0
```

```

        -0.316  -0.507  0.802    0
        -0.632  -0.169  -1.6     1
P0.show("P0:");
└ P0: (0, 0, 0)
P1.show("P1:");
└ P1: (0, 0, 3.74)

```

The following example shows how `align_with_axis()` can be used for putting plane figures into a major plane.

```

default_focus.set(2, 3, -10, 2, 3, 10, 10);
Circle c(origin, 3, 75, 25, 6);
c.shift(2, 3);
c.draw();
Point n = c.get_normal();
n.shift(c.get_center());
Transform t;
t.align_with_axis(c.get_center(), n, 'y');
t.show("t:");
└ t:
    0.686  0.379  -0.621    0
    0.543   0.3   0.784    0
    0.483  -0.875   0       0
        -3  -1.66  -1.11    1
n *= c *= t;
c.draw();
c.show("c:");
└ c:
fill_draw_value == 0
(1.31, 0, -0.728) .. (1.49, 0, -0.171) ..
(1.44, 0, 0.413) .. (1.17, 0, 0.933) ..
(0.728, 0, 1.31) .. (0.171, 0, 1.49) ..
(-0.413, 0, 1.44) .. (-0.933, 0, 1.17) ..
(-1.31, 0, 0.728) .. (-1.49, 0, 0.171) ..
(-1.44, 0, -0.413) .. (-1.17, 0, -0.933) ..
(-0.728, 0, -1.31) .. (-0.171, 0, -1.49) ..
(0.413, 0, -1.44) .. (0.933, 0, -1.17) .. cycle;
n.show("n:");
└ n: (0, 1, 0)

```

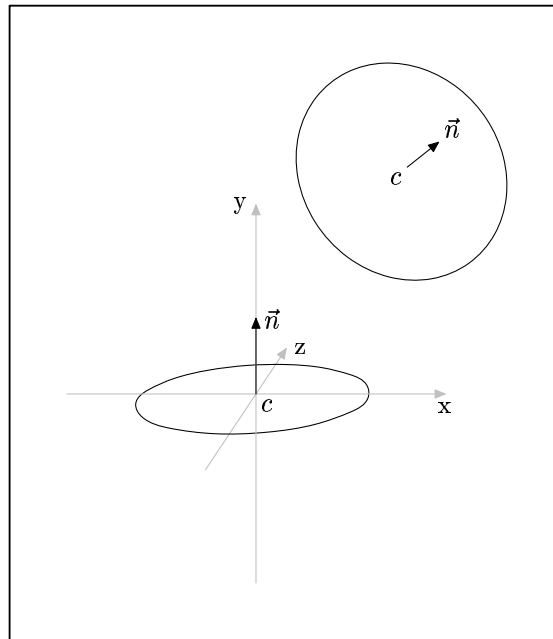

Figure 75.

## 19.12 Resetting

`void reset (void)`

Resets *matrix* to the identity matrix.

[Function]

## 19.13 Cleaning

`void clean (void)`

Sets elements in *matrix* whose absolute values are  $< \text{epsilon}()$  to 0.

[Function]

## 20 Label Reference

Class `Label` is defined in ‘`pictures.web`’. `Point` and `Picture` are friends of `Label`.

Labels can be included in drawings by using the `label()` and `dotlabel()` functions, which are currently defined for the classes `Point` and `Path`, and the classes derived from them. See Section 22.19 [Point Reference; Labelling], page 146, and See Section 26.13 [Path Reference; Labelling], page 190. They are currently not defined for `Solid`, and its derived classes. I plan to add them for `Solid` soon.

Users will normally never need to declare objects of type `Label`, access its data members or call its member functions directly.

When `label()` or `dotlabel()` is invoked, one or more `Labels` is allocated dynamically and pointers to the new `Labels` are placed onto the `vector<Label*> labels` of a `Picture: current_picture`, by default. There are no explicitly defined constructors for `Label`, nor is it intended that `Labels` ever be created in any way other than through `label()` or `dotlabel()`. When a `Picture` is copied, the `Labels` are copied, too, and when a `Picture` is cleared (using `Picture::clear()`) or destroyed, the `Labels` are deallocated and destroyed.

### 20.1 Data Members

`Point* pt` [Private variable]  
A pointer to the `Point` representing the location of the `Label`.

`bool dot` [Private variable]  
`true` if the label should be dotted, otherwise `false`.

`dot` will be `false`, if the label was generated by a call to `label()` with the “`dot`” argument `false` (the default), `true`, if the label was generated by a call to `dotlabel()`, or to `label()` with the “`dot`” argument `true`.

`string text` [Private variable]  
The text of the label. `text` is always put between “`btex`” and “`etex`” in the MetaPost code, so that `TEX` will be used to format the labels. In particular, this means that `TEX`’s math mode can be used. However, double backslashes must be used instead of single backslashes, in order that single backslashes be written to `out_stream`.

```
Point P(1, 1, 2);
origin.drawarrow(P);
P.label("$\\vec{P}$");
```

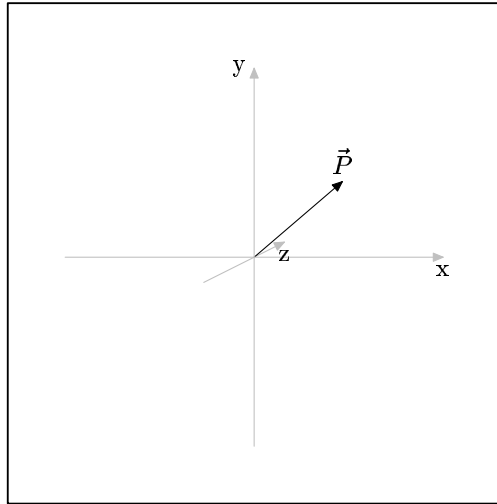

Figure 76.

**string position** [Private variable]  
 The position of the text with respect to **\*pt**. Valid values are as in MetaPost: “top”, “bot” (bottom), “lft” (left), “rt” (right), “ulft” (upper left), “llft” (lower left), “urt” (upper right), “lrt” (lower right).

**bool DO\_LABELS** [Public static variable]  
 Enables or disables creation of **Labels**. If **true**, **label** and **dotlabel()** cause **Labels** to be created and put onto a **Picture**. If **false**, they are not. Note that it is also possible to suppress output of existing **Labels** when outputting a **Picture**.

## 20.2 Copying

**Label\* get\_copy (void)** [const Function]  
 Creates a copy of the **Label** and returns a pointer to the copy. Called in **Picture::operator=()** and **Picture::operator+=()** where **Pictures** are copied. Users should never need to call this function directly. See Section 21.4 [Picture Reference; Operators], page 111.  
 This function dynamically allocates a new **Label** and a new **Point** within the **Label**, and copies the **strings** from **\*this** to the new **Label**. The standard library functions for **strings** take care of the allocation for the **string** members of **Label**.

## 20.3 Outputting

**void output (const Focus& f, const unsigned short proj, real factor, const Transform& t)** [Function]  
 Writes MetaPost code for the labels to **out\_stream**. It is called in **Picture::output()** (see Section 21.8 [Picture Reference; Outputting], page 113). Users should never need to call this function directly.  
 When **Picture::output()** is invoked, the MetaPost code for **Labels** is written to **out\_stream** after the code for the drawing and filling commands. This prevents the **Labels** from being covered up. However, they can still be covered by other **Labels**, or



by `Shapes` or `Labels` from subsequent invocations of `Picture::output()` within the same figure (see Section 17.2 [I/O Functions], page 91, for descriptions of `beginfig()` and `endfig()`).

## 21 Picture Reference

Class `Picture` is defined in `'pictures.web'`.

### 21.1 Data Members

**Transform transform** [Private variable]

Applied to the `Shapes` on the `Picture` when the latter is output. It is initialized as the identity `Transform`, and can be modified by the transformation functions, by `Picture::operator*=(const Transform&)` (see Section 21.4 [Picture Reference; Operators], page 111), and by `Picture::set_transform()` (see Section 21.6 [Picture Reference; Modifying], page 112).

**vector<Shape\*> shapes** [Private variable]

Contains pointers to the `Shapes` on the `Picture`. When a drawing or filling function is invoked for a `Shape`, a copy is dynamically allocated and a pointer to the copy is placed onto `shapes`.

**vector<Label\*> labels** [Private variable]

Contains pointers to the `Labels` on the `Picture`. When a `Point` is labelled, either directly or through a call to `label()` or `dotlabel()` for another type of `Shape`<sup>1</sup>, a `Label` is dynamically allocated, the `Point` is copied to `*Label::pt`, and a pointer to the `Label` is placed onto `labels`.

**bool do\_labels** [Private variable]

Used for enabling or disabling output of `Labels` when outputting a `Picture`. The default value is `true`. It is set to `false` by using `suppress_labels()` and can be reset to `true` by using `unsuppress_labels()`. See Section 21.8.2 [Picture Reference; Output Functions], page 114.

Often, when a `Picture` is copied, transformed, and output again in a single figure, it's undesirable to have the `Labels` output again in their new positions. To avoid this, use `suppress_labels()` after outputting the `Picture` the first time.

### 21.2 Global Variables

**Variable Picture current\_picture** [Variable]

The `Picture` used as the default by the drawing and filling functions.

### 21.3 Constructors

**void Picture (void)** [Default constructor]

Creates an empty `Picture`.

---

<sup>1</sup> `label()` and `dotlabel()` are currently only defined for `Point` and `Path` (and the latter's derived classes), i.e., not for `Solid` and its derived classes.

`void Picture (const Picture& p)` [Copy constructor]

Creates a copy of `Picture p`.

```
Circle c(origin, 3);
c.draw();
current_picture.output(Projections::PARALLEL_X_Z);
Picture new_picture(current_picture);
new_picture.shift(2);
new_picture.output(Projections::PARALLEL_X_Z);
```

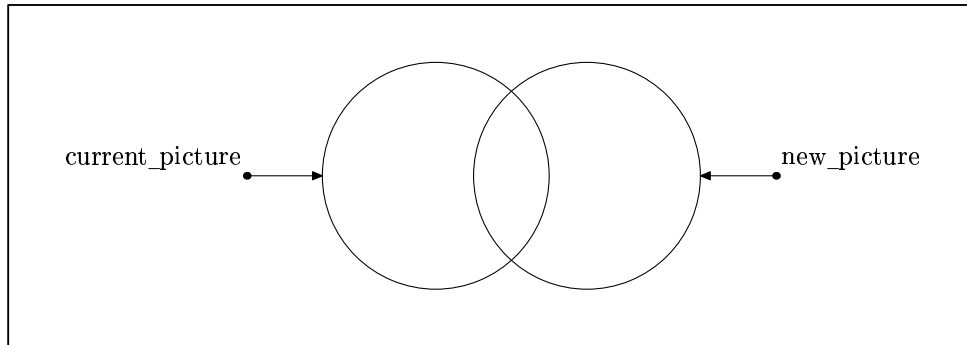

Figure 77.

## 21.4 Operators

`void operator= (const Picture& p)` [Assignment operator]

Makes `*this` a copy of `p`, destroying the old contents of `*this`.

`void operator+= (const Picture& p)` [Operator]

Adds the contents of `p` to `*this`. `p` remains unchanged.

`void operator+= (Shape* s)` [Operator]

Puts `s` onto `shapes`. Note that the pointer `s` itself is put onto `shapes`, so any allocation and copying must be performed first. This is a low-level function that users normally won't need to use directly.

`void operator+= (Label* label)` [Operator]

Puts `label` onto `labels`. Note that the pointer `label` itself is put onto `labels`, so any allocation and copying must be performed first. This is a low-level function that users normally won't need to invoke directly.

`Transform operator*= (const Transform& t)` [Operator]

Multiplies `transform` by `t`. This has the effect of transforming all of the `Shapes` on `shapes` and all of the `Points` of the `Labels` on `labels` by `t` upon output.

```
Transform t;
t.rotate(0, 0, 180);
t.shift(3);
Reg_Polygon pl(origin, 5, 3, 90);
pl.draw();
pl.label();
```

```
current_picture.output(Projections::PARALLEL_X_Y);
current_picture *= t;
current_picture.output(Projections::PARALLEL_X_Y);
```

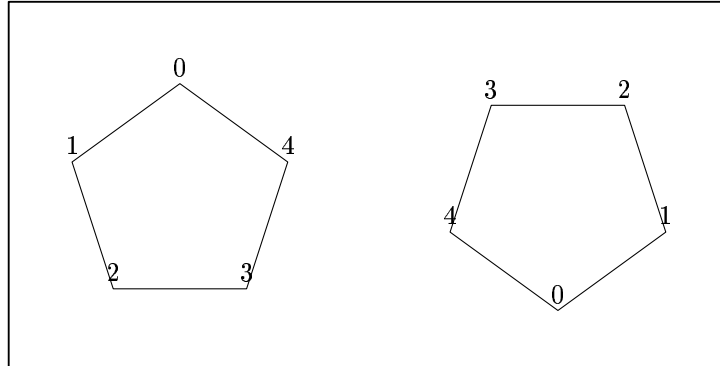

Figure 78.

## 21.5 Affine Transformations

The functions in this section all operate on the `transform` data member of the `Picture` and return a `Transform` representing the transformation—*not* `transform`.

**Transform `scale`** (`real x`, [`real y = 1`, [`real z = 1`]]) [Function]

Performs `transform.scale(x, y, z)` and returns the result. This has the effect of scaling all of the elements of `shapes` and `labels`.

**Transform `shift`** (`real x`, [`real y = 0`, [`real z = 0`]]) [Function]

Performs `transform.shift(x, y, z)` and returns the result. This has the effect of shifting all of the `Shapes` and `Labels` on the `Picture`.

**Transform `shift`** (`const Point& p`) [Function]

Performs `transform.shift(p)` and returns the result. This has the effect of shifting all of the `Shapes` and `Labels` on the `Picture` by the `x`, `y`, and `z`-coordinates of `p`.

**Transform `rotate`** (`const real x`, [`const real y = 0`, [`const real z = 0`]]) [Function]

Performs `transform.rotate(x, y, z)` and returns the result. This has the effect of rotating all of the elements of `shapes` and `labels`.

**Transform `rotate`** (`const Point& p0`, `const Point& p1`, [`const real angle = 180`]); [Function]

Performs `transform.rotate(p0, p1, angle)` and returns the result. This has the effect of rotating all of the elements of `shapes` and `labels` about the line  $\overrightarrow{p_0 p_1}$ .

## 21.6 Modifying

**void `clear`** (`void`) [Function]

Destroys the `Shapes` and `Labels` on the `Picture` and removes all the `Shape` pointers from `shapes` and the `Label` pointers from `labels`. All dynamically allocated objects

are deallocated, namely the `Shapes`, the `Labels`, and the `Points` belonging to the `Labels`. `transform` is reset to the identity `Transform`.

`void reset_transform (void)` [Function]  
Resets `transform` to the identity `Transform`.

`Transform set_transform (const Transform& t)` [Function]  
Sets `transform` to `t` and returns `t`.

`void kill_labels (void)` [Function]  
Removes the `Labels` from the `Picture`.

## 21.7 Showing

`void show ([string text = "", [bool stop = false]])` [Function]  
Prints information about the `Picture` to standard output.

`show()` first prints the string "Showing Picture:" to standard output, followed by `text`, if the latter is not the empty string ("")<sup>2</sup>. Then it calls `transform.show()`, prints the size of `shapes` and `labels`, and the value of `do_labels`. Then it calls `show()` on each of the `Shapes` on `shapes`. Since `show()` is a virtual function in class `Shape`, the appropriate `show()` is called for each `Shape`, i.e., `Point::show()` for a `Point`, `Path::show()` for a `Path`, etc. If `stop` is `true`, execution stops and the user is requested to type <RETURN> to continue. Finally, the string "Done showing picture." is printed to standard output.

`void show_transform ([string text = "Transform from Picture:"])` [Function]  
Calls `transform.show()`, passing `text` as the argument to the latter function.

## 21.8 Outputting

### 21.8.1 Namespaces

#### 21.8.1.1 Namespace Projections

The namespace `Projections` is defined in 'pictures.web'.

`const unsigned short PERSP` [Constant]  
`const unsigned short PARALLEL_X_Y` [Constant]  
`const unsigned short PARALLEL_X_Z` [Constant]  
`const unsigned short PARALLEL_Z_Y` [Constant]  
`const unsigned short AXON` [Constant]  
`const unsigned short ISO` [Constant]

These constants can be used for the *projection* argument in `Picture::output()`, described in Section 21.8.2 [Picture Reference; Outputting; Functions], page 114, below.

---

<sup>2</sup> Actually, it's printed to standard output even if it is the empty string, you just don't see it.

### 21.8.1.2 Namespace Sorting

The namespace `Sorting` is defined in `'pictures.web'`.

```
const unsigned short NO_SORT [Constant]
const unsigned short MAX_Z [Constant]
const unsigned short MIN_Z [Constant]
const unsigned short MEAN_Z [Constant]
```

These constants can be used for the `sort_value` argument in `Picture::output()`, described in Section 21.8.2 [Picture Reference; Outputting; Functions], page 114, below.

### 21.8.2 Output Functions

```
void output (const Focus& f, [const unsigned short projection = [Function]
    Projections::PERSP, [real factor = 1, [const unsigned short sort_value
    = Sorting::MAX_Z, [const bool do_warnings = true, [const real
    min_x_proj = -40, [const real max_x_proj = 40, [const real min_y_proj =
    -40, [const real max_y_proj = 40, [const real min_z_proj = -40, [const
    real max_z_proj = 40]]]]]]]]))
void output ([const unsigned short projection = [Function]
    Projections::PERSP, [real factor = 1, [const unsigned short sort_value
    = Sorting::MAX_Z, [const bool do_warnings = true, [const real
    min_x_proj = -40, [const real max_x_proj = 40, [const real min_y_proj =
    -40, [const real max_y_proj = 40, [const real min_z_proj = -40, [const
    real max_z_proj = 40]]]]]]]]))
```

These functions create a two-dimensional projection of the objects on the `Picture` and write MetaPost code to `out_stream` for drawing it.

The arguments:

`const Focus& f`

The `Focus` used for projection, also known as the center of projection, or the camera. This argument is used in the first version only. The second version, without a `const Focus& f` argument, merely calls the first version and passes it the global variable `default_focus` as its first argument, so `default_focus` is effectively the default for `f`. Defining two versions in this way makes it possible to call `output()` with `projection` as its first (and possibly only) argument. If instead, `f` were an optional argument with `default_focus` as its default, this wouldn't have been possible. It also wouldn't be possible to have `f` have a default in the first version, and to retain the second version, because the compiler wouldn't be able to resolve a call to `output()` with no arguments.

`const unsigned short projection`

Default: `Projections::PERSP`. The type of projection. Valid values are `const unsigned shorts` defined in namespace `Projections` (see Section 21.8.1.1 [Namespace Projections], page 113):

`PERSP` for the perspective projection,

PARALLEL\_X\_Y for parallel projection onto the x-y plane,  
 PARALLEL\_X\_Z for parallel projection onto the x-z plane, and  
 PARALLEL\_Z\_Y for parallel projection onto the z-y plane. %% !! TO DO:  
 I plan to add isometric and axionometric projections soon.

**real factor**

Default: 1. Passed from `output()` to `extract()` and from there to `project()`. The `world_coordinates` of the `Points` that are projected are multiplied by `factor`, which enlarges or shrinks the projected image without altering the `Picture` itself. `factor` is probably most useful for parallel projections, where the `Focus f` isn't used; with a perspective projection, the parameters of the `Focus` can be used to influence the size of the projected image.

**const unsigned short sort\_value**

Default: `Sorting::MAX_Z`. The value used should be one of the constants defined in namespace `Sorting`, See Section 21.8.1.2 [Namespace `Sorting`], page 114, above. If `MAX_Z` (the default) is used, the `Shapes` on the `Picture` are sorted according to the maximum z-value of the `projective_extremes` of the `Points` belonging to the `Shape`. If `MIN_Z` is used, they are sorted according to the minimum z-value, and if `MEAN_Z` is used, they are sorted according to the mean of the maximum and minimum z-values. If `NO_SORT` is used, the `Shapes` are output in the order in which they were put onto the `Picture`.

The surface hiding algorithm implemented in 3DLDF is quite primitive, and doesn't always work right. For `Shapes` that intersect, it *can't* work right. I plan to work on improving the surface hiding algorithm soon. This is not a trivial problem. To solve it properly, each `Shape` on a `Picture` must be tested for intersection with every other `Shape` on the `Picture`. If two or more `Shapes` intersect, they must be broken up into smaller objects until there are no more intersections. I don't expect to have a proper solution soon, but I expect that I will be able to make some improvements. See Section 9.3 [Surface Hiding], page 66.

**const bool do\_warnings**

Default: `true`. If `true`, `output()` issues warnings to `stderr` (standard error output) if a `Shape` cannot be output because it lies outside the limits set by the following arguments. Sometimes, a user may only want to project a portion of a `Picture`, in which case such warnings would not be helpful. In this case, `do_warnings` should be `false`.

**const real min\_x\_proj**

Default: -40. The minimum x-coordinate of the projection of a `Shape` such that the `Shape` can be output. If `projective_coordinates[0]` of any `Point` on a `Shape` is less than `min_x_proj`, the `Shape` will not be projected at all.

**const real max\_x\_proj**

Default: 40. The maximum x-coordinate of the projection of a `Shape` such that the `Shape` can be output. If `projective_coordinates[0]` of

any **Point** on a **Shape** is greater than *max\_x\_proj*, the **Shape** will not be projected at all.

**const real** *min\_y\_proj*

Default: -40. The minimum y-coordinate of the projection of a **Shape** such that the **Shape** can be output. If **projective\_coordinates**[1] of any **Point** on a **Shape** is less than *min\_y\_proj*, the **Shape** will not be projected at all.

**const real** *max\_y\_proj*

Default: 40. The maximum y-coordinate of the projection of a **Shape** such that the **Shape** can be output. If **projective\_coordinates**[1] of any **Point** on a **Shape** is greater than *max\_y\_proj*, the **Shape** will not be projected at all.

**const real** *min\_z\_proj*

Default: -40. The minimum z-coordinate of the projection of a **Shape** such that the **Shape** can be output. If **projective\_coordinates**[2] of any **Point** on a **Shape** is less than *min\_z\_proj*, the **Shape** will not be projected at all.

**const real** *max\_z\_proj*

Default: 40. The maximum z-coordinate of the projection of a **Shape** such that the **Shape** can be output. If **projective\_coordinates**[2] of any **Point** on a **Shape** is greater than *max\_z\_proj*, the **Shape** will not be projected at all.

**void** **suppress\_labels** (**void**) [Function]

Suppresses output of the **Labels** on a **Picture** when **output()** is called. This can be useful when a **Picture** is output, transformed, and output again, one or more times, in a single figure. Usually, it will not be desirable to have the **Labels** output more than once.

In Fig. 79, **current\_picture** is output three times, but the **Labels** on it are only output once.

```

    Ellipse e(origin, 3, 5);
    e.label();
    e.draw();
    Point pt0(-3);
    Point pt1(3);
    pt0.draw(pt1);
    Point pt2(0, 0, -4);
    Point pt3(0, 0, 4);
    pt2.draw(pt3);
    pt0.dotlabel("0", "lft");
    pt1.dotlabel("1", "rt");
    pt2.dotlabel("2", "bot");
    pt3.dotlabel("3");
    current_picture.output(Projections::PARALLEL_X_Z);
    current_picture.rotate(0, 60);

```



```

current_picture.suppress_labels();
current_picture.output(Projections::PARALLEL_X_Z);
current_picture.rotate(0, 60);
current_picture.output(Projections::PARALLEL_X_Z);

```

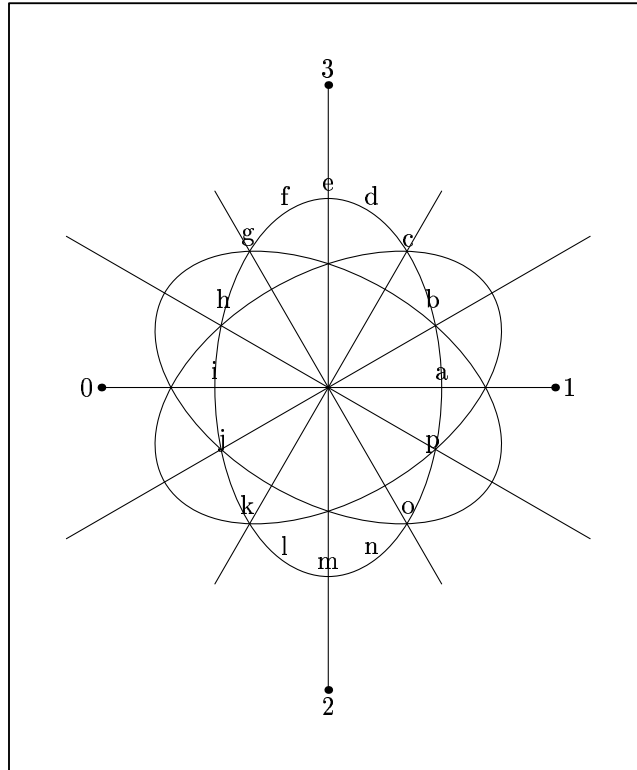

Figure 79.

**void unsuppress\_labels** (void)

[Inline function]

Sets `do_labels` to `true`. If a `Picture` contains `Labels`, `unsuppress_labels()` ensures that they will be output, when `Picture::output()` is called, so long as there is no intervening call to `suppress_labels()` or `kill_labels()`.

## 22 Point Reference

Class `Point` is defined in `'points.web'`. It is derived from `Shape` using `protected` derivation. The function `Transform Transform::align_with_axis(Point, Point, char)` is a friend of `Point`.

### 22.1 Data Members

`valarray<real> world_coordinates` [Private variable]

The set of four homogeneous coordinates `x`, `y`, `z`, and `w` that represent the position of the `Point` within 3DLDF's global coordinate system.

`valarray<real> projective_coordinates` [Private variable]

The set of four homogeneous coordinates `x`, `y`, `z`, and `w` that represent the position of the *projection* of the `Point` onto a two-dimensional plane for output. The `x` and `y` values are used in the `MetaPost` code written to `out_stream`. The `z` value is used in the hidden surface algorithm (which is currently rather primitive and doesn't work very well. see Section 9.3 [Surface Hiding], page 66). The `w` value can be  $\neq 1$ , depending on the projection used; the perspective projection is non-affine, so `w` can take on other values.

`valarray<real> user_coordinates` [Private variable]

A set of four homogeneous coordinates `x`, `y`, `z`, and `w`.

`user_coordinates` currently has no function. It is intended for use in user-defined coordinate systems. For example, a coordinate system could be defined with respect to a plane surface that isn't parallel to one of the major planes. Such a coordinate system would be convenient for drawing on the plane. A `Transform` would make it possible to convert between `user_coordinates` and `world_coordinates`.

`valarray<real> view_coordinates` [Private variable]

A set of four homogeneous coordinates `x`, `y`, `z`, and `w`.

`view_coordinates` currently has no function. It may be useful for displaying multiple views in an interactive graphical user interface, or for some other purpose.

`Transform transform` [Private variable]

Contains the product of the transformations applied to the `Point`. When `apply_transform()` is called for the `Point`, directly or indirectly, the `world_coordinates` are updated and `transform` is reset to the identity `Transform`. See Section 22.13 [Point Reference; Applying Transformations], page 134.

`bool on_free_store` [Private variable]

Returns `on_free_store`. This should only be `true` if the `Point` was dynamically allocated on the free store. `Points` should only ever be dynamically allocated by `create_new<Point>()`, which uses `set_on_free_store()` to set `on_free_store` to `true`. See Section 22.4 [Point Reference; Constructors and Setting Functions], page 122, and Section 22.11 [Point Reference; Modifying], page 129.

**signed short drawdot\_value** [Private variable]  
 Used to tell `Point::output()` what MetaPost drawing command (`drawdot()` or `undrawdot()`) to write to `out_stream` when outputting a `Point`.

When `drawdot()` or `undrawdot()` is called on a `Point`, the `Point` is copied and put onto the `Picture`, which was passed to `drawdot()` or `undrawdot()` as an argument (`current_picture` by default). `drawdot_value` is either set to `Shape::DRAWDOT` or `Shape::UNDRAWDOT` on the copy; `this->drawdot` is not set.

**const Color\* drawdot\_color** [Private variable]  
 Used to tell `Point::output()` what string to write to `out_stream` for the color when outputting a `Point`.

**string pen** [Private variable]  
 Used to tell `Point::output()` what string to write to `out_stream` for the pen when outputting a `Point`.

**valarray<real> projective\_extremes** [Protected variable]  
 A set of 6 `real` values indicating the maximum and minimum x, y, and z-coordinates of the `Point`. Used for determining whether a `Point` is projectable with the parameters of a particular invocation of `Picture::output()`. See Section 21.8 [Picture Reference; Outputting], page 113.

Obviously, the maxima and minima will always be the same for a `Point`, namely the x, y, and z-coordinates. However, `set_extremes()` and `get_extremes()`, the functions that access `projective_extremes`, are pure virtual functions in `class Shape`, so the `Point` versions must be consistent with the versions for other types derived from `Shape`.

**bool do\_output** [Protected variable]  
`true` by default. Set to `false` by `suppress_output()`, which is called on a `Shape` by `Picture::output()`, if the `Shape` is not projectable. See Section 21.8 [Picture Reference; Outputting], page 113.

**string measurement\_units** [Public static variable]  
 The unit of measurement for all distances within a `Picture`, "cm" (for centimeters) by default. The x and y-coordinates of the projected `Points` are always followed by `measurement_units` when they're written to `out_stream`. Unlike Metafont, units of measurement cannot be indicated for individual coordinates. Nor can `measurement_unit` be changed within a `Picture`.

When I write an input routine, I plan to make it behave the way Metafont does, however, 3DLDF will probably also convert all of the input values to a standard unit, as Metafont does.

**real CURR\_Y** [Public static variable]  
**real CURR\_Z** [Public static variable]

Default values for the y and z-coordinate of `Points`, when the x-coordinate, or the x and y-coordinates only are specified. Both are 0 by default.

These values only used in the constructor and setting function taking one required **real** value (for the x-coordinate), and two optional **real** values (for the y and z-coordinates). They are not used when a **Point** is declared using the default constructor with no arguments. In this case, the x, y, and z-coordinates will all be 0. See Section 22.4 [Point Reference; Constructors and Setting Functions], page 122.

```
Point A(1);
A.show("A:");
└ A: (1, 0, 0);
CURR_Y = 5;
A.set(2);
A.show("A:");
└ A: (2, 5, 0);
CURR_Z = 12;
Point B(3);
B.show("B:");
└ B: (3, 5, 12);
Point C;
C.show("C:");
└ C: (0, 0, 0);
```

## 22.2 Typedefs and Utility Structures

**point\_pair** *first second* [typedef]

Synonymous with `pair<Point, Point>`.

**bool\_point** *b pt* [struct]

*b* is a `bool` and *pt* is a `Point`. `bool_point` also contains two constructors and an assignment operator, described below.

**void bool\_point** (void) [Default constructor]

Creates a `bool_point` and sets *b* to `false` and *pt* to `INVALID_POINT`.

**void bool\_point** (bool *bb*, const `Point&` *ppt*) [Default constructor]

Creates a `bool_point` and sets *b* to *bb* and *pt* to *ppt*.

**void bool\_point::operator=** (const `bool_point&` *bp*) [Assignment operator]

Sets *b* to *bp.b* and *pt* to *bp.pt*.

**bool\_point\_pair** *first second* [typedef]

Synonymous with `pair <bool_point, bool_point>`.

**bool\_point\_quadruple** *first second third fourth* [struct]

This structure contains four `bool_points`. It also has two constructors and an assignment operator, described below.

**void bool\_point\_quadruple** (void) [Default constructor]

Creates a `bool_point_quadruple`, and sets *first*, *second*, *third*, and *fourth* all to `INVALID_BOOL_POINT`.

**void bool\_point\_quadruple** (bool\_point a, bool\_point b, bool\_point c, bool\_point d) [Constructor]  
 Creates a bool\_point\_quadruple and sets first to a, second to b, third to c, and fourth to d.

**void bool\_point\_quadruple::operator=** (const bool\_point\_quadruple& arg) [Assignment operator]  
 Makes \*this a copy of arg.

**bool\_real\_point b r pt** [struct]  
 b is a bool, r is a real, and pt is a Point. bool\_real\_point also contains three constructors and an assignment operator, described below.

**void bool\_real\_point** (void) [Default constructor]  
 Creates a bool\_real\_point and sets b to false, r to INVALID\_REAL and pt to INVALID\_POINT.

**void bool\_real\_point** (const bool\_real\_point& brp) [Copy constructor]  
 Creates a bool\_real\_point and sets b to brp.b, r to brp.r, and pt to brp.pt.

**void bool\_real\_point** (const bool& bb, const real& rr, const Point& ppt) [Constructor]  
 Creates a bool\_real\_point and sets b to bb, r to rr, and pt to ppt.

**void bool\_real\_point::operator=** (const bool\_real\_point& brp) [Assignment operator]  
 Makes \*this a copy of brp.

## 22.3 Global Constants and Variables

**Point INVALID\_POINT** [Constant]  
 The x, y, and z-values in world\_coordinates are all INVALID\_REAL.

**Point origin** [Constant]  
 The x, y, and z-values in world\_coordinates are all 0.

**bool\_point INVALID\_BOOL\_POINT** [Constant]  
 b is false and pt is INVALID\_POINT.

**bool\_point\_pair INVALID\_BOOL\_POINT\_PAIR** [Constant]  
 first and second are both INVALID\_BOOL\_POINT.

**bool\_real\_point INVALID\_BOOL\_REAL\_POINT** [Constant]  
 b is false, r is INVALID\_REAL, and pt is INVALID\_POINT.

**bool\_point\_quadruple INVALID\_BOOL\_POINT\_QUADRUPLE** [Constant]  
 first, second, third, and fourth are all INVALID\_BOOL\_POINT.

## 22.4 Constructors and Setting Functions

**void Point** (void) [Default constructor]  
Creates a **Point** and initializes its *x*, *y*, and *z*-coordinates to 0.

**void Point** (const real *x*, [const real *y* = CURR\_Y, [const real *z* = CURR\_Z]]) [Constructor]  
Creates a **Point** and initializes its *x*, *y*, and *z*-coordinates to the values of the arguments *x*, *y*, and *z*. The arguments *y* and *z* are optional. If they are not specified, the values of **CURR\_Y** and **CURR\_Z** are used. They are 0 by default, but can be changed by the user. This can be convenient, if all of the **Points** being drawn in a particular section of a program have the same *z* or *y* and *z* values.

**void set** (const real *x*, [const real *y* = CURR\_Y, [const real *z* = CURR\_Z]]) [Setting function]  
Corresponds to the constructor above, but is used for resetting the coordinates of an existing **Point**.

**void Point** (const **Point**& *p*) [Copy constructor]  
Creates a **Point** and copies the values for its *x*, *y*, and *z*-coordinates from *p*.

**void set** (const **Point**& *p*) [Setting function]  
Corresponds to the copy constructor above, but is used for resetting the coordinates of an existing **Point**. This function exists purely as a convenience; the operator **operator=()** (see Section 22.6 [Point Reference; Operators], page 123) performs exactly the same function.

**Point\*** **create\_new**<**Point**> (const **Point**\* *p*) [Template specializations]  
**Point\*** **create\_new**<**Point**> (const **Point**& *p*)

Pseudo-constructors for dynamic allocation of **Points**. They create a **Point** on the free store and allocate memory for it using **new(Point)**. They return a pointer to the new **Point**.

If *p* is a non-zero pointer or a reference, the new **Point** will be a copy of *p*. If the new object is not meant to be a copy of an existing one, '0' must be passed to **create\_new<Point>()** as its argument. See Chapter 14 [Dynamic Allocation of Shapes], page 83, for more information.

One use for **create\_new<Point>** is in the constructors for classes of objects that can contain a variable number of **Points**, such as **Path** and **Polygon**. Another use is in the drawing and filling functions, where objects are copied and the copies put onto a **Picture**.

Programmers who dynamically allocate **Points** must ensure that they are deallocated properly using **delete**!

## 22.5 Destructor

`void ~Point (void)` [virtual Destructor]

This function currently has an empty definition, but its existence prevents GCC 3.3 from issuing the following warning: “\thinspace ‘class Point’ has virtual functions but non-virtual destructor”.

## 22.6 Operators

`void operator= (const Point& p)` [Assignment operator]

Makes `*this` a copy of `p`.

`Transform operator*= (const Transform& t)` [Operator]

Multiplies `transform` by `t`. By multiplying a `Point` successively by one or more `Transforms`, the effect of the transformations is “saved up” in `transform`. Only when an operation that needs updated values for the `world_coordinates` is called on a `Point`, or the `Point` is passed as an argument to such an operation, is the transformation stored in `transform` applied to `world_coordinates` by `apply_transform()`, which subsequently, resets `transform` to the identity `Transform`. See Section 22.13 [Point Reference; Applying Transformations], page 134.

`Point operator+ (Point p)` [const operator]

Returns a `Point` with `world_coordinates` that are the sums of the corresponding `world_coordinates` of `*this` and `p`, after they’ve been updated. `*this` remains unchanged; as in many other functions with `Point` arguments, `p` is passed by value, because `apply_transform()` must be called on it, in order to update its `world_coordinates`. If `p` were a `const Point&`, it would have to be copied within the function anyway, because `apply_transform()` is a non-`const` operation.

```
Point p0(-2, -6, -28);
Point p1(3, 14, 92);
Point p2(p0 + p1);
p2.show("p2:");
└─ p2: (1, 8, 64)
```

`void operator+= (Point p)` [Operator]

Adds the updated `world_coordinates` of `p` to those of `*this`. Equivalent in effect to `shift(p)`. In fact, this function merely calls `p.apply_transform()` and `Point::shift(real, real, real)` with `p`’s `x`, `y`, and `z` coordinates (from `world_coordinates`) as its arguments. See Section 22.12 [Point Reference; Affine Transformations], page 129.

`Point operator- (Point p)` [const operator]

Returns a `Point` with `world_coordinates` representing the difference between the updated values of `this->world_coordinates` and `p.world_coordinates`.

`void operator-= (Point p)` [Operator]

Subtracts the updated values of `p.world_coordinates` from those of `this->world_coordinates`.

**real operator\*=** (const real r) [Operator]

Multiplies the updated x, y, and z coordinates (`world_coordinates`) of the `Point` by `r` and returns `r`. This makes it possible to chain invocations of this function.

If `P` is a `Point` then `P *= r` is equivalent in its effect to `P.scale(r, r, r)`, except that `P.world_coordinates` is modified directly and immediately, without changing `P.transform`. This is possible, because this function calls `apply_transform()` to update the `world_coordinates` before multiplying them `r`, so `transform` is the identity `Transform`.

```
Point P(1, 2, 3);
P *= 7;
P.show("P:");
└ P: (7, 14, 21);
Point Q(1.5, 2.7, 13.82);
Q *= P *= -1.28;
P.show("P:");
└ P: (-8.96, -17.92, -26.88)
Q.show("Q:");
└ Q: (-1.92, -3.456, -17.6896)
```

**Point operator\*** (const real r) [const operator]

Returns a `Point` with x, y, and z coordinates (`world_coordinates`) equal to the updated x, y, and z coordinates of `*this` multiplied by `r`.

**Point operator\*** (const real r, const Point& p) [Non-member operator]

Equivalent to `Point::operator*(const real r)` (see above), but with `r` placed first.

```
Point p0(10, 11, 12);
real r = 2.5;
Point p1 = r * p0;
p1.show();
└Point:
└ (25, 27.5, 30)
```

**Point operator-** (void) [const operator]

Unary minus (prefix). Returns a `Point` with x, y, and z coordinates (`world_coordinates`) equal to the the x, y, and z-coordinates (`world_coordinates`) of `*this` multiplied by -1.

**void operator/=** (const real r) [Operator]

Divides the updated x, y, and z coordinates (`world_coordinates`) of the `Point` by `r`.

**Point operator/** (const real r) [const operator]

Returns a `Point` with x, y, and z coordinates (`world_coordinates`) equal to the updated x, y, and z coordinates of `*this` divided by `r`.

**bool operator==** (Point p) [Operator]

**bool operator==** (const Point& p) [const operator]

Equality comparison for `Points`. These functions return `true` if the updated values of the `world_coordinates` of the two `Points` differ by less than the value returned by



`Point::epsilon()`, otherwise `false`. See Section 22.10 [Point Reference; Returning Information], page 128.

`bool operator!= (const Point& p)` [const operator]  
Inequality comparison for Points. Returns `false` if `*this == p`, otherwise `true`.

## 22.7 Copying

`Shape* get_copy (void)` [const function]  
Creates a copy of the `Point`, and allocates memory for it on the free store using `create_new<Point>()`. It returns a pointer to `Shape` that points to the new `Point`. This function is used in the drawing commands for putting `Points` onto `Pictures`. See Section 22.18 [Point Reference; Drawing], page 143.

## 22.8 Querying

`bool is_identity (void)` [inline function]  
Returns `true` if `transform` is the identity `Transform`.

`Transform get_transform (void)` [const inline function]  
Returns `transform`.

`bool is_on_free_store (void)` [const function]  
Returns `true` if memory for the `Point` has been dynamically allocated on the free store, i.e., if the `Point` has been created using `create_new<Point>()`. See Section 22.4 [Point Reference; Constructors and Setting Functions], page 122.

`bool is_on_plane (const Plane& p)` [const function]  
Returns `true`, if the `Point` lies on the `Plane p`, otherwise `false`.

Planes are conceived of as having infinite extension, so while the `Point C` in Fig. 80 does not lie within the `Rectangle r`, it does lie on `q`, so `C.is_on_plane(q)` returns `true`.<sup>1</sup>

```
Point P(1, 1, 1);
Rectangle r(P, 4, 4, 20, 45, 35);
Plane q = r.get_plane();
Point A(2, 0, 2);
Point B(2, 1.64143, 2);
Point C(0.355028, 2.2185, 6.48628);
cout << A.is_on_plane(q);
+ 0
cout << B.is_on_plane(q);
+ 1
cout << "C.is_on_plane(q)";
```

<sup>1</sup> It's unlikely that `Points` will lie on a `Plane`, unless the user constructs the case specially. In Fig. 80, the coordinates for `B` and `C` were found by using `Plane::intersection_point()`. See Section 25.6 [Planes; Intersections], page 160.

† 1

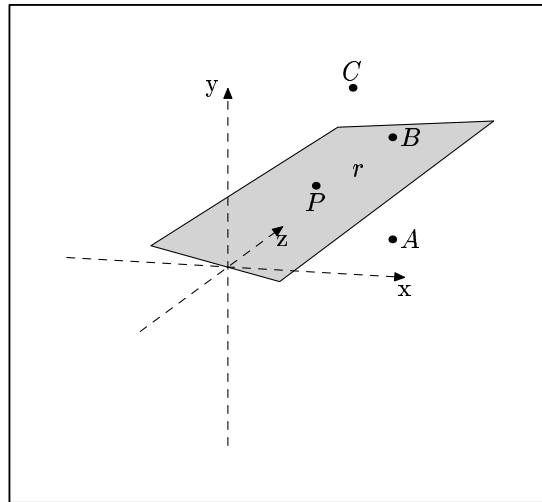

Figure 80.

```
bool is_in_triangle (const Point& p0, const Point& p1, const [const function]
                    Point& p2, [bool verbose = false, [bool test_points = true]])
```

Returns `true`, if `*this` lies within the triangle determined by the three `Point` arguments, otherwise `false`.

If the code calling `is_in_triangle()` has ensured that  $p_0$ ,  $p_1$ , and  $p_2$  determine a plane, i.e., that they are not colinear, and that `*this` lies in that plane, then `false` can be passed to `is_in_triangle()` as its `test_points` argument.

If the `verbose` argument is `true`, information resulting from the execution of the function are printed to standard output or standard error.

This function is needed for determining whether a line intersects with a polygon.

## 22.9 Returning Coordinates

The functions in this section return either a single coordinate or a set of coordinates. Each has a `const` and a non-`const` version.

The arguments are the same, with one exception:

`char c` Only in `get_coord()`. Indicates which coordinate should be returned. Valid values are 'x', 'X', 'y', 'Y', 'z', 'Z', 'w', and 'W'.

`char coords`

Indicates the set of coordinates which should be returned or from which the coordinate to be returned should be chosen from. Valid values are 'w' for `world_coordinates` (the default), 'p' for `projective_coordinates`, 'u' for `user_coordinates`, and 'v' for `view_coordinates`.

`const bool do_persp`

Only relevant if `projective_coordinates`, or one of its elements is to be returned. If `true`, the default, then `project()` is called, thereby generating

values for `projective_coordinates`. If `do_persp` is false, then `projective_coordinates`, or one of its elements, is returned unchanged, which may sometimes be useful.

`const bool do_apply`

If true (the default), `apply_transform()` is called, thereby updating the `world_coordinates`. Otherwise, it's not, so that the values stored in `world_coordinates` remain unchanged. Note that if `coords` is 'p' and `do_persp` is true, `apply_transform()` will be called in `project()` whether `do_apply` is true or false. If for some reason, one wanted get `projective_coordinates`, or one of its values, based on the projection of `world_coordinates` without first updating them, one would have to call `reset_transform()` before calling one of these functions. It would probably be a good idea to save `transform` before doing so.

**Focus\* *f*** Indicates what Focus is to be used for projection. Only relevant if `coords` is 'p', i.e., `projective_coordinates`, or one of its elements, is to be returned. The default is 0, in which case *f* points to the global variable `default_focus`.

`const unsigned short proj`

Indicates what form of projection is to be used. Only relevant if `coords` is 'p', i.e., `projective_coordinates`, or one of its elements, is to be returned. The default is `Projections::PERSP`, which causes the perspective projection to be applied.

`real factor`

Passed to `project()`. The values of the x and y coordinates in `projective_coordinates` are multiplied by *factor*. Only relevant if `coords` is 'p', i.e., `projective_coordinates`, or one of its elements, is to be returned. The default is 1.

`valarray <real> get_all_coords` ([char *coords* = 'w', [const bool [Function] *do\_persp* = true, [const bool *do\_apply* = true, [Focus\* *f* = 0, [const unsigned short *proj* = `Projections::PERSP`, [real *factor* = 1]]]]])

Returns one of the sets of coordinates; `world_coordinates` by default. Returns a complete set of coordinates: 'w' for `world_coordinates`, 'p' for `projective_coordinates`, 'u' for `user_coordinates`, or 'v' for `view_coordinates`.

`real get_coord` (char *c*, [char *coords* = 'w', [const bool *do\_persp* = [Function] true, [const bool *do\_apply* = true, [Focus\* *f* = 0, [const unsigned short *proj* = `Projections::PERSP`, [real *factor* = 1]]]]])

Returns one coordinate, x, y, z, or w, from the set of coordinates indicated (or `world_coordinates`, by default).

`real get_x` ([char *coords* = 'w', [const bool *do\_persp* = true, [const [Function] bool *do\_apply* = true, [Focus\* *f* = 0, [const unsigned short *proj* = `Projections::PERSP`, [real *factor* = 1]]]]])

Returns the x-coordinate from the set of coordinates indicated (or `world_coordinates`, by default).

```
real get_y ([char coords = 'w', [const bool do_persp = true, [const [Function]
    bool do_apply = true, [Focus* f = 0, [const unsigned short proj =
    Projections::PERSP, [real factor = 1]]]]]])
```

Returns the y-coordinate from the set of coordinates indicated (or world\_ coordinates, by default).

```
real get_z ([char coords = 'w', [const bool do_persp = true, [const [Function]
    bool do_apply = true, [Focus* f = 0, [const unsigned short proj =
    Projections::PERSP, [real factor = 1]]]]]])
```

Returns the z-coordinate from the set of coordinates indicated (or world\_ coordinates, by default).

```
real get_w ([char coords = 'w', [const bool do_persp = true, [const [Function]
    bool do_apply = true, [Focus* f = 0, [const unsigned short proj =
    Projections::PERSP, [real factor = 1]]]]]])
```

Returns the w-coordinate from the set of coordinates indicated (or world\_ coordinates, by default).

## 22.10 Returning Information

```
real epsilon (void) [Static function]
```

Returns the positive real value of smallest magnitude  $\epsilon$  that should be used as a coordinate value in a Point. A coordinate of a Point may also contain  $-\epsilon$ .

The value  $\epsilon$  is used for testing the equality of Points in Point::operator==( ) (see Section 22.6 [Point Reference; Operators], page 123):

Let  $\epsilon$  be the value returned by epsilon(),  $P$  and  $Q$  be Points, and  $P_x$ ,  $Q_x$ ,  $P_y$ ,  $Q_y$ ,  $P_z$ , and  $Q_z$  the updated x, y, and z-coordinates of  $P$  and  $Q$ , respectively. If and only if  $||P_x| - |Q_x|| < \epsilon$ ,  $||P_y| - |Q_y|| < \epsilon$ , and  $||P_z| - |Q_z|| < \epsilon$ , then  $P = Q$ .

epsilon() returns different values, depending on whether real is float or double: If real is float (the default), epsilon() returns 0.00001. If real is double, it returns 0.000000001.

**Please note:** I haven't tested whether 0.000000001 is a good value yet, so users should be aware of this if they set real to double!<sup>2</sup> The way to test this is to start with two Points  $P$  and  $Q$  at different locations. Then they should be transformed using different rotations in such a way that they should end up at the same location. Let  $\epsilon$  stand for the value returned by epsilon(), and let  $x$ ,  $y$ , and  $z$  stand for the world\_ coordinates of the Points after apply\_transform() has been called on them. If  $x_P = x_Q$ ,  $y_P = y_Q$ , and  $z_P = z_Q$ ,  $\epsilon$  is a good value.

Rotation causes a significant loss of precision to due to the use of the sin() and cos() functions. Therefore, neither Point::epsilon() nor Transform::epsilon() (see Section 19.8 [Tranform Reference; Returning Information], page 99) can be as small as I'd like them to be. If they are two small, operations that test for equality of Transforms and Points will return false for objects that should be equal.

---

<sup>2</sup> For that matter, I haven't really tested whether 0.00001 is a good value when real is float.

## 22.11 Modifying

`bool set_on_free_store ([bool b = true])` [Virtual function]

This function is used in the template function `create_new()`. It sets `on_free_store` to `true`. See Section 22.1 [Point Reference; Data Members], page 118, and Section 22.4 [Point Reference; Constructors and Setting Functions], page 122.

`void clear (void)` [Function]

Sets all of the coordinates in all of the sets of coordinates (i.e., `world_coordinates`, `user_coordinates`, `view_coordinates`, and `projective_coordinates`) to 0 and resets `transform`

`void clean ([int factor = 1])` [Function]

Calls `apply_transform()` and sets the values of `world_coordinates` to 0, whose absolute values are less than `epsilon() × factor`.

`void reset_transform (void)` [Function]

Sets `Transform` to the identity `Transform`. Performed in `apply_transform()`, after the latter updates `world_coordinates`. Section 22.13 [Point Reference; Applying Transformations], page 134.

## 22.12 Affine Transformations

`Transform rotate (const real x, [const real y = 0, [const real z = 0]])` [Function]

`Transform rotate (const Point& p0, const Point& p1, [const real angle = 180])` [Function]

`Transform rotate (const Path& p, [const real angle = 180])` [Function]

Each of these functions calls the corresponding version of `Transform::rotate()`, and returns its return value, namely, a `Transform` representing the rotation only.

In the first version, taking three `real` arguments, the `Point` is rotated `x` degrees around the x-axis, `y` degrees around the y-axis, and `z` degrees around the z-axis in that order.

```
Point p0(1, 0, 2);
p0.rotate(90);
p0.show("p0:")
  | p0: (1, 2, 0)
Point p1(-1, 1, 1);
p1.rotate(-90, 90, 90);
p1.show("pt1:");
  | p1: (1, -1, -1)
```

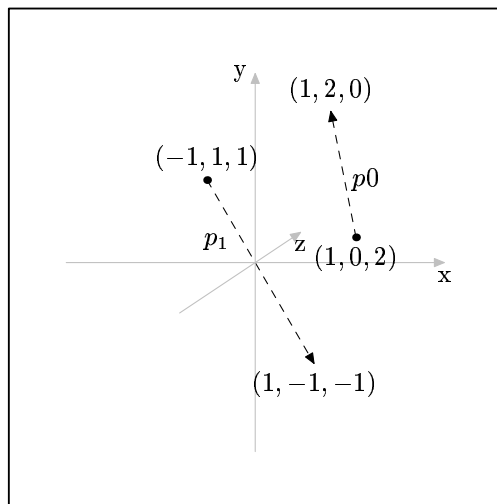

Figure 81.

Please note that rotations are not commutative operations. Nor are they commutative with other transformations. So, if you want to rotate a `Point` about the x, y and z-axes in that order, you can do so with a single invocation of `rotate()`, as in the previous example. However, if you want to rotate a `Point` first about the y-axis and then about the x-axis, you must invoke `rotate()` twice.

```
Point pt0(1, 1, 1);
pt0.rotate(0, 45);
pt0.rotate(45);
pt0.show("pt0:");
└ pt0: (0, 1.70711, 0.292893)
```

In the version taking two `Point` arguments `p0` and `p1`, and a `real` argument `angle`, the `Point` is rotated `angle` degrees around the axis determined by `p0` and `p1`,  $180^\circ$  by default.

```
Point P(2, 0, 0);
Point A;
Point B(2, 2, 2);
P.rotate(A, B, 180);
```

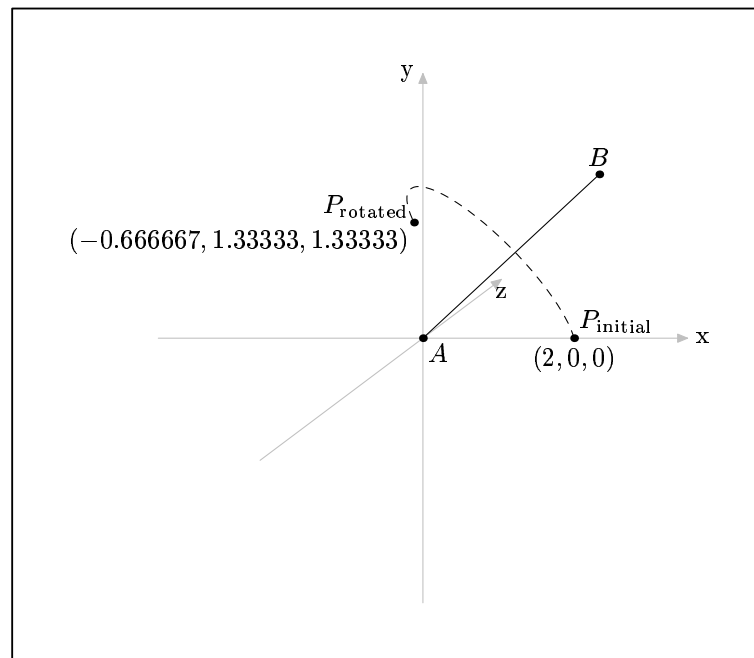

Figure 82.

**Transform scale** (real  $x$ , [real  $y = 1$ , [real  $z = 1$ ]]) [Function]  
 Calls `transform.scale(x, y, z)` and returns its return value, namely, a `Transform` representing the scaling operation only.

Scaling causes the x-coordinate of the `Point` to be multiplied by  $x$ , the y-coordinate of the `Point` to be multiplied by  $y$ , and the z-coordinate of the `Point` to be multiplied by  $z$ .

```
Point p0(1, 0, 3);
p0.scale(4);
p0.show("p0:");
└ p0: (4, 0, 3)
Point p1(-2, -1, -2);
p1.scale(-2, -3, -4);
p1.show("p1:");
└ p1: (4, 3, 8)
```

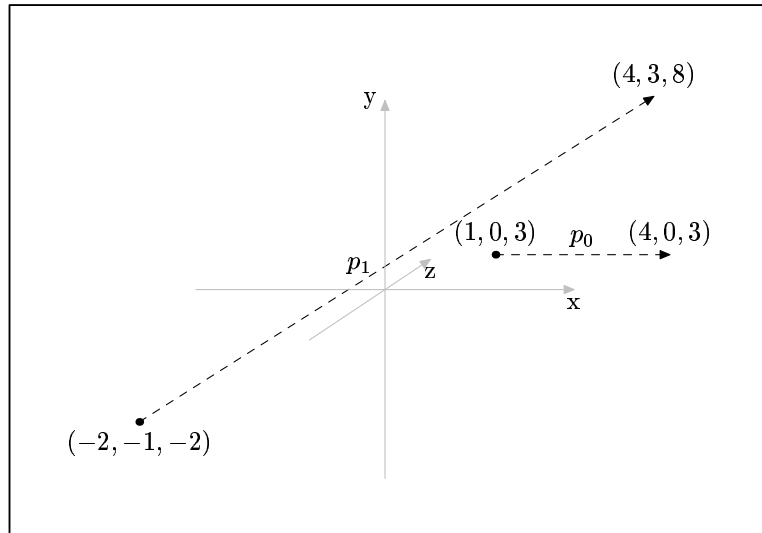

Figure 83.

Transform **shear** (real xy, [real xz = 0, [real yx = 0, [real yz = 0, [Function]  
[real zx = 0, [real zy = 0]]]]])

Calls `transform.shear()` with the same arguments and returns its return value, namely, a **Transform** representing the shearing operation only.

Shearing modifies each coordinate of a **Point** proportionately to the values of the other two coordinates. Let  $x_0$ ,  $y_0$ , and  $z_0$  stand for the coordinates of a **Point**  $P$  before `P.shear( $\alpha$ ,  $\beta$ ,  $\gamma$ ,  $\delta$ ,  $\epsilon$ ,  $\zeta$ )`, and  $x_1$ ,  $y_1$ , and  $z_1$  for its coordinates afterwards.

$$\begin{aligned}x_1 &\equiv x_0 + \alpha y + \beta z \\y_1 &\equiv y_0 + \gamma x + \delta z \\z_1 &\equiv z_0 + \epsilon x + \zeta y\end{aligned}$$

Fig. 84 demonstrates the effect of shearing the four **Points** of a  $3 \times 3$  **Rectangle** (i.e., a square)  $r$  in the x-y plane using only an `xy` argument, making it non-rectangular.

```
Point P0;
Point P1(3);
Point P2(3, 3);
Point P3(0, 3);
Rectangle r(p0, p1, p2, p3);
r.draw();
r.shear(1.5);
r.draw(black, "evenly");
```



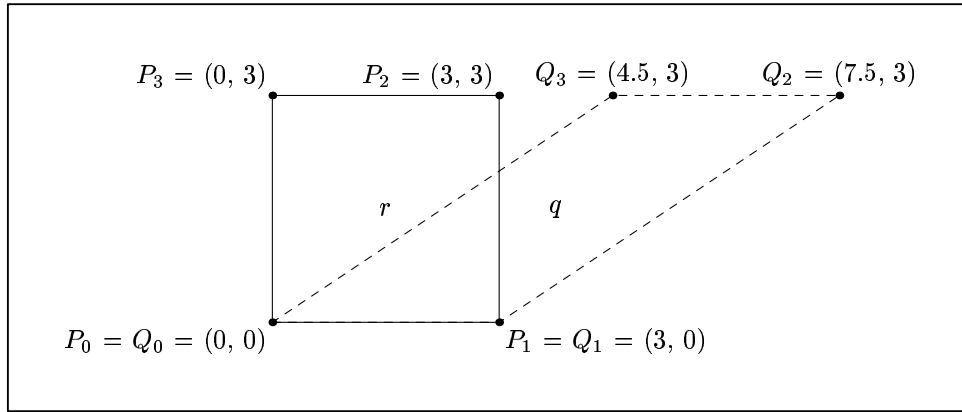

Figure 84.

Transform **shift** (real x, [real y = 0, [real z = 0]]) [Function]

Transform **shift** (const Point& p) [Function]

Each of these functions calls the corresponding version of `Transform::shift()` on `transform`, and returns its return value, namely, a `Transform` representing the shifting operation only.

The `Point` is shifted `x` units in the direction of the positive x-axis, `y` units in the direction of the positive y-axis, and `z` units in the direction of the positive z-axis.

```
p0(1, 2, 3);
p0.shift(2, 3, 5);
p0.show("p0:");
└─ p0: (3, 5, 8)
```

Transform **shift\_times** (real x, [real y = 1, [real z = 1]]) [Function]

Transform **shift\_times** (const Point& p) [Function]

Each of these functions calls the corresponding version of `Transform::shift_times()` on `transform` and returns its return value, namely the new value of `transform`.

`shift_times()` makes it possible to increase the magnitude of a shift applied to a `Point`, while maintaining its direction. Please note that `shift_times()` will only have an effect if it's called after a call to `shift()` and before `transform` is reset. This is performed by `reset_transform()`, which is called in `apply_transform()`, and can also be called directly. See Section 19.12 [Transform Reference; Resetting], page 106, and Section 22.13 [Point Reference; Applying Transformations], page 134.

```
Point P;
P.drawdot();
P.shift(1, 1, 1);
P.drawdot();
P.shift_times(2, 2, 2);
P.drawdot();
P.shift_times(2, 2, 2);
P.drawdot();
P.shift_times(2, 2, 2);
P.drawdot();
```

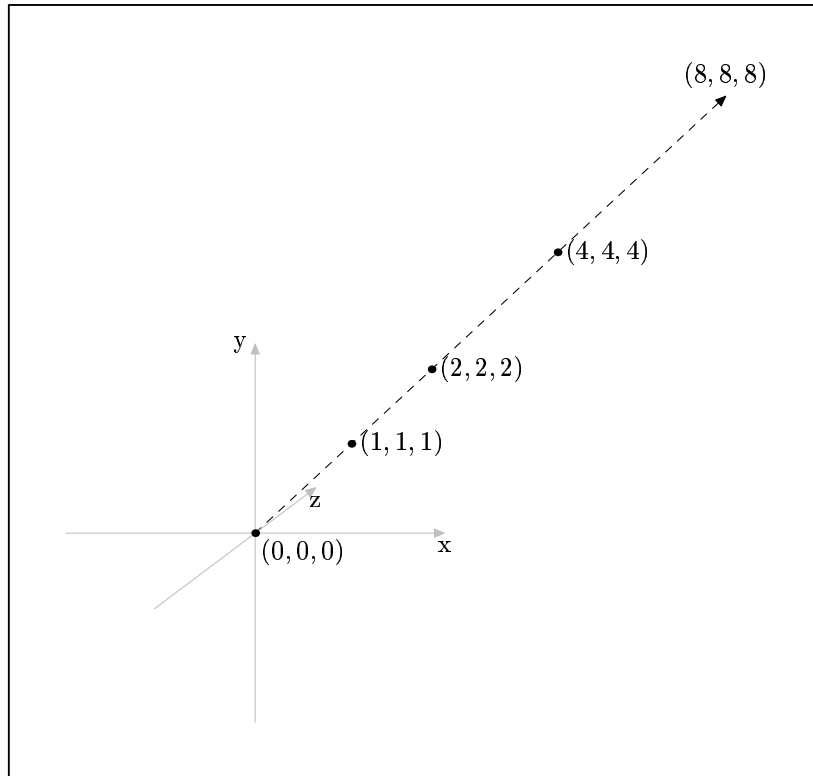

Figure 85.

## 22.13 Applying Transformations

`void apply_transform (void)` [Function]  
 Updates `world_coordinates` by multiplying it by `transform`, which is subsequently reset to the identity `Transform`.

## 22.14 Projecting

`bool project (const Focus& f, [const unsigned short proj = Projections::PERSP, [real factor = 1]])` [Function]  
`bool project ([const unsigned short& proj = Projections::PERSP, [real factor = 1]])` [Function]

These functions calculate `projective_coordinates`. `proj` indicates which projection is to be performed. If it is `Projections::PERSP`, then `f` indicates which `Focus` is to be used (in the first version), or the global variable `default_focus` is used (in the second). If `Projections::PARALLEL_X_Y`, `Projections::PARALLEL_X_Z`, or `Projections::PARALLEL_Z_Y` is used, `f` is ignored, since these projections don't use a `Focus`. Currently, no other projections are defined. The x and y coordinates in `projective_coordinates` are multiplied by `factor` with the default being 1.

## 22.15 Vector Operations

Mathematically speaking, vectors and points are not the same. However, they can both be represented as triples of real numbers (in a three-dimensional Cartesian space). It is sometimes convenient to treat points as though they were vectors, and vice versa. In particular, it is convenient to use the same data type, namely `class Point`, to represent both points and vectors in 3DLDF.

**real dot\_product** (`Point p`) [`const` function]

Returns the dot or scalar product of `*this` and `p`.

If `P` and `Q` are `Points`,

$$P \bullet Q = x_P x_Q + y_P y_Q + z_P z_Q = |P||Q| \cos(\theta)$$

where  $|P|$  and  $|Q|$  are the magnitudes of `P` and `Q`, respectively, and  $\theta$  is the angle between `P` and `Q`.

Since

$$\theta = \arccos\left(\frac{P \bullet Q}{|P||Q|}\right),$$

the dot product can be used for finding the angle between two vectors.

```
Point P(1, -1, -1);
Point Q(3, 2, 5);
cout << P.angle(Q);
+ 112.002
cout << P.dot_product(Q);
+ -4
real P_Q_angle = (180.0 / PI)
                 * acos(P.dot_product(Q)
                       / (P.magnitude() * Q.magnitude()));
cout << P_Q_angle;
+ 112.002
```

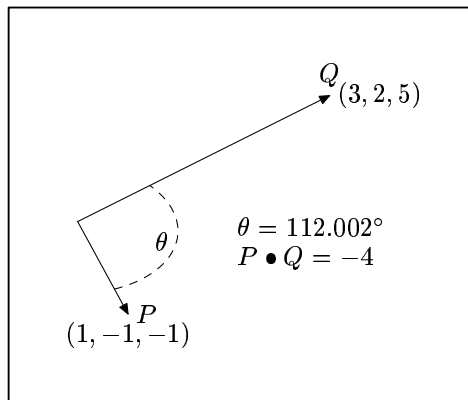

Figure 86.

If the angle  $\theta$  between two vectors `P` and `Q` is  $90^\circ$ , then  $\cos(\theta)$  is 0, so  $P \bullet Q$  will also be 0. Therefore, `dot_product()` can be used as a test for the orthogonality of vectors.

```

Point P(2);
Point Q(P);
Point Q0(P0);
Q0 *= Q.rotate(0, 0, 90);
P *= Q.rotate(0, 45, 45);
P *= Q.rotate(45);
cout << P.angle(Q);
+ 90
cout << P.dot_product(Q);
+ 0

```

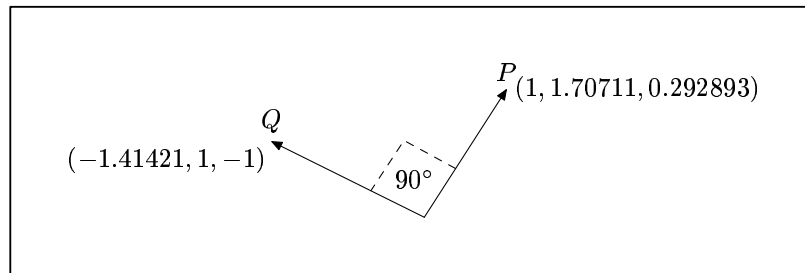

Figure 87.

Point **cross\_product** (Point *p*) [const function]

Returns the cross or vector product of *\*this* and *p*.

If *P* and *Q* are Points,

$$P \times Q = ((y_P z_Q - z_P y_Q), (z_P x_Q - x_P z_Q), (x_P y_Q - y_P x_Q)) = |P||Q| \sin(\theta) \hat{n},$$

where  $|P|$  and  $|Q|$  are the magnitudes of *P* and *Q*, respectively,  $\theta$  is the angle between *P* and *Q*, and  $\hat{n}$  is a unit vector perpendicular to both *P* and *Q* in the direction of a right-hand screw from *P* towards *Q*. Therefore, `cross_product()` can be used to find the normals to planes.

```

Point P(2, 2, 2);
Point Q(-2, 2, 2);
Point n = P.cross_product(Q);
n.show("n:");
+ n: (0, -8, 8)
real theta = (PI / 180.0) * P.angle(Q);
cout << theta;
+ 1.23096
real n_mag = P.magnitude() * Q.magnitude() * sin(theta);
cout << n_mag;
+ 11.3137
n /= n_mag;
cout << n.magnitude();
+ 1

```

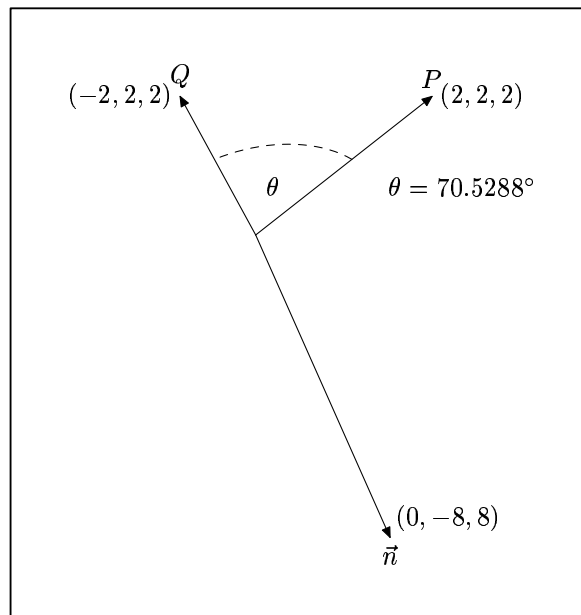

Figure 88.

If  $\theta = 0^\circ$  or  $180^\circ$ ,  $\sin(\theta)$  will be 0, and  $P \times Q$  will be  $(0, 0, 0)$ . The cross product thus provides a test for parallel vectors.

```
Point P(1, 2, 1);
Point Q(P);
Point R;
R *= Q.shift(-3, -1, 1);
Point s(Q - R);
Point n = P.cross_product(s);
n.show("n:");
└ n: (0, 0, 0)
```

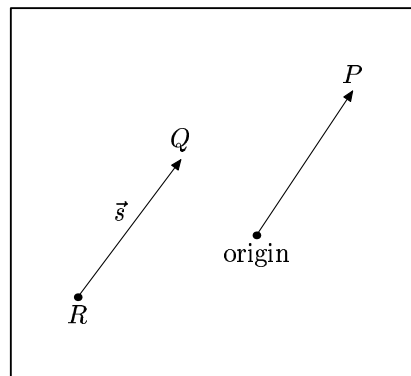

Figure 89.

**real magnitude** (void)

[const function]

Returns the magnitude of the Point. This is its distance from origin and is equal to  $\sqrt{x^2 + y^2 + z^2}$ .

```
Point P(13, 15.7, 22);
cout << P.magnitude();
└ 29.9915
```

**real angle** (Point *p*) [const function]

Returns the angle in degrees between two Points.

```
Point P(3.75, -1.25, 6.25);
Point Q(-5, 2.5, 6.25);
real angle = P.angle(Q);
cout << angle;
+ 73.9084
Point n = origin.get_normal(P, Q);
n.show("n:");
+ n: (0.393377, 0.91788, -0.0524503)
```

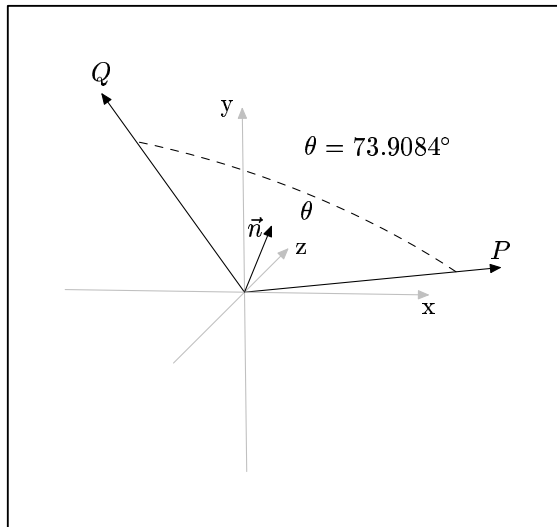

Figure 90.

**Point unit\_vector** (const bool *assign*, [const bool *silent* = false]) [Function]

**Point unit\_vector** (void) [const function]

These functions return a Point with the x, y, and z-coordinates of world-coordinates divided by the magnitude of the Point. The magnitude of the resulting Point is thus 1. The first version assigns the result to *\*this* and should only ever be called with *assign* = true. Calling it with the argument false is equivalent to calling the const version, with no assignment. If *unit\_vector*() is called with *assign* and *silent* both false, it issues a warning message is issued and the const version is called. If *silent* is true, the message is suppressed.

```
Point P(21, 45.677, 91);
Point Q = P.unit_vector();
Q.show("Q:");
+ Q: (0.201994, 0.439357, 0.875308)
P.rotate(30, 25, 10);
P.show("P:");
P: (-19.3213, 82.9627, 59.6009)
cout << P.magnitude();
+ 103.963
P.unit_vector(true);
```

```

P.show("P:");
+ P: (-0.185847, 0.797999, 0.573287)
cout << P.magnitude();
+ 1

```

## 22.16 Points and Lines

**Line** `get_line` (`const Point& p`) [const function]  
Returns the `Line l` corresponding to the line from `*this` to `p`. `l.position` will be `*this`, and `l.direction` will be `p - *this`. See Chapter 24 [Line Reference], page 153.

**real** `slope` (`Point p`, [`char m = 'x'`], [`char n = 'y'`]]) [const function]  
Returns a `real` number representing the slope of the *trace* of the line defined by `*this` and `p` on the plane indicated by the arguments `m` and `n`.

```

Point p0(3, 4, 5);
Point p1(2, 7, 12);
real r = p0.slope(p1, 'x', 'y');
⇒ r ≡ -3
r = p0.slope(p1, 'x', 'z');
⇒ r ≡ -7
r = p0.slope(p1, 'z', 'y');
⇒ r ≡ 0.428571

```

**bool\_real** `is_on_segment` (`Point p0`, `Point p1`) [Function]  
**bool\_real** `is_on_segment` (`const Point& p0`, `const Point& p1`) [const function]

These functions return a `bool_real`, where the `bool` part is `true`, if the `Point` lies on the line segment between `p0` and `p1`, otherwise `false`. If the `Point` lies on the line segment, the `real` part is a value `r` such that  $0 \leq r \leq 1$  indicating how far the `Point` is along the way from `p0` to `p1`. For example, if the `Point` is half of the way from `p0` to `p1`, `r` will be `.5`. If the `Point` does not lie on the line segment, but on the *line* passing through `p0` and `p1`, `r` will be `< 0` or `> 1`.

If the `Point` doesn't lie on the line passing through `p0` and `p1`, `r` will be `INVALID_REAL`.

```

Point p0(-1, -2, 1);
Point p1(3, 2, 5);
Point p2(p0.mediate(p1, .75));
Point p3(p0.mediate(p1, 1.5));
Point p4(p2);
p4.shift(-2, 1, -1);
bool_real br = p2.is_on_segment(p0, p1);
cout << br.first;
+ 1
cout << br.second;
+ 0.75
bool_real br = p3.is_on_segment(p0, p1);
cout << br.first;

```

```

+ 0
cout << br.second;
+ 1.5
bool_real br = p4.is_on_segment(p0, p1);
cout << br.first;
+ 0
cout << br.second;
+ 3.40282e+38
cout << (br.second == INVALID_REAL)
+ 1

```

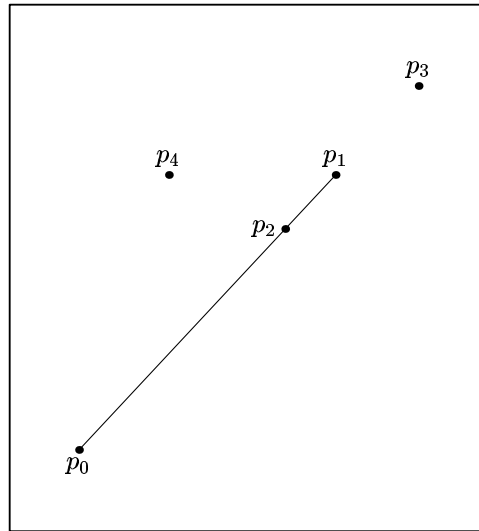

Figure 91.

**bool\_real is\_on\_line** (const Point& p0, const Point& p1) [const function]

Returns a **bool\_real** where the **bool** part is **true**, if the **Point** lies on the line passing through **p0** and **p1**, otherwise **false**. If the **Point** lies on the line, the **real** part is a value **r** indicating how far the **Point** is along the way from **p0** to **p1**, otherwise **INVALID\_REAL**. The following values of **r** are possible for a call to **P.is\_on\_line(A, B)**, where the **Point P** lies on the line  $\overrightarrow{AB}$ :

$P \equiv A \implies r \equiv 0.$

$P \equiv B \implies r \equiv 1.$

$P$  lies on the opposite side of  $A$  from  $B \implies r < 0.$

$P$  lies between  $A$  and  $B \implies 0 < r < 1.$

$P$  lies on the opposite side of  $A$  from  $B \implies r > 1$

```

Point A(-1, -2);
Point B(2, 3);
Point C(B.mediate(A, 1.25));
bool_real br = C.is_on_line(A, B);

```



```

Point D(A.mediate(B));
br = D.is_on_line(A, B);
Point E(A.mediate(B, 1.25));
br = E.is_on_line(A, B);
Point F(D);
F.shift(-1, 1);
br = F.is_on_line(A, B);

```

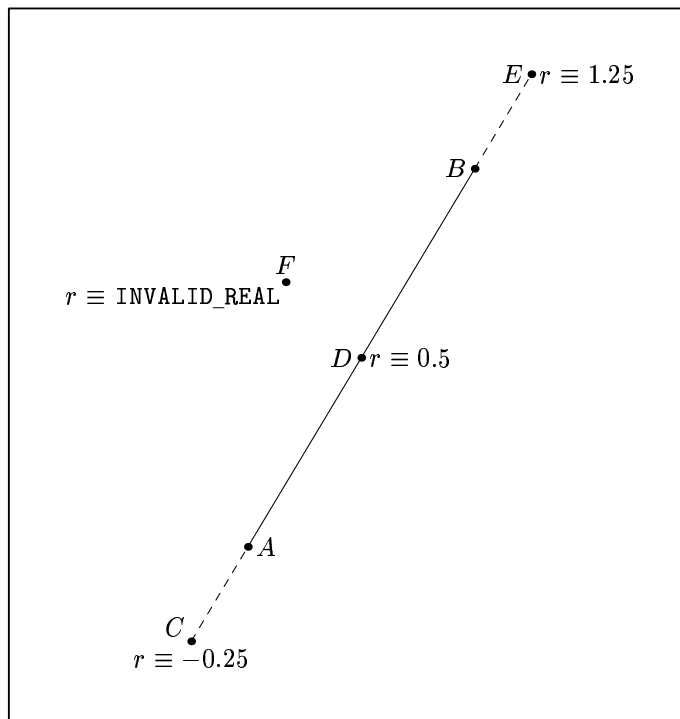

Figure 92.

Point **mediate** (Point *p*, [const real *r* = .5])  
 Returns a Point *r* of the way from *\*this* to *p*.

[const function]

```

Point p0(-1, 0, -1);
Point p1(10, 0, 10);
Point p2(5, 5, 5);
Point p3 = p0.mediate(p1, 1.5);
p3.show("p3:");
└ p3: (15.5, 0, 15.5)
Point p4 = p0.mediate(p2, 1/3.0);
p4.show("p4:");
└ p4: (1, 1.66667, 1)

```

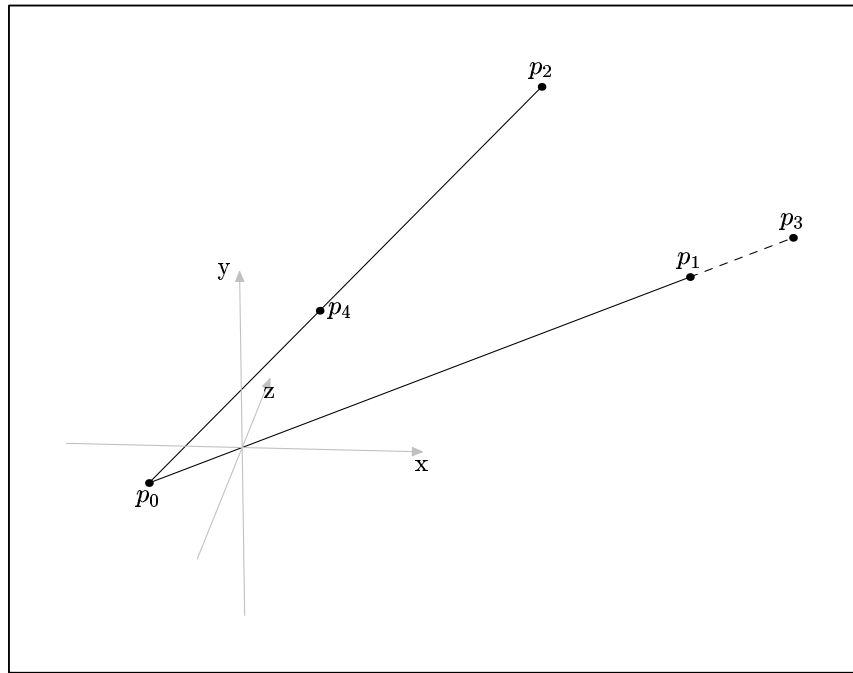

Figure 93.

## 22.17 Intersections

`bool_point intersection_point` (Point *p0*, Point *p1*, Point *q0*, Point *q1*) [Static function]

`bool_point intersection_point` (Point *p0*, Point *p1*, Point *q0*, Point *q1*, const bool *trace*) [Static function]

These functions find the intersection point, if any, of the lines determined by *p0* and *p1* on the one hand, and *q0* and *q1* on the other.

Let `bp` be the `bool_point` returned by `intersection_point()`. If an intersection point is found, the corresponding `Point` will be stored in `bp.pt`, otherwise, `bp.pt` will be set to `INVALID_POINT`. If the intersection point lies on both of the line segments, `bp.b` will be `true`, otherwise, `false`.

The two versions use different methods of finding the intersection point. The first uses a vector calculation, the second looks for the intersections of the traces of the lines on the major planes. If the *trace* argument is used, the second version will be called, whether *trace* is `true` or `false`. Ordinarily, there should be no need to use the trace version.

```
Point A(-1, -1);
Point B(1, 1);
Point C(-1, 1);
Point D(1, -1);
bool_point bp = Point::intersection_point(A, B, C, D);
bp.pt.dotlabel("$i$");
cout << "bp.b == " << bp.b << endl << flush;
-| bp.b == 1
```

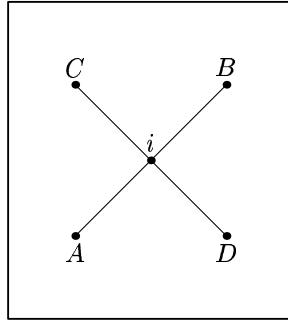

Figure 94.

```

Point A(.5, .5);
Point B(1.5, 1.5);
Point C(-1, 1);
Point D(1, -1);
bool_point bp = Point::intersection_point(A, B, C, D, true);
bp.pt.dotlabel("$i$");
cout << "bp.b == " << bp.b << endl << flush;
└ bp.b == 0

```

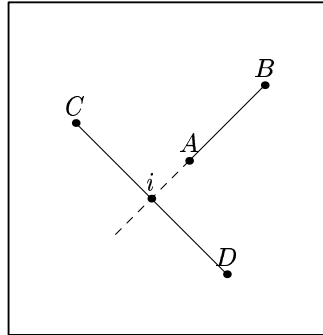

Figure 95.

## 22.18 Drawing

There are two versions for each of the drawing functions. The second one has the `Picture` argument `picture` at the beginning of the argument list, rather than at the end. This is convenient when passing a `picture` argument. Where `picture` is optional, the default is always `current_picture`.

```

void drawdot ([const Color& ddrawdot_color = [const function]
             *Colors::default_color, [const string ppen = "", [Picture& picture =
             current_picture]]])
void drawdot ([Picture& picture = current_picture, [const [const function]
             Color& ddrawdot_color = *Colors::default_color, [const string ppen =
             "", ]]])

```

Draws a dot on `picture`. If `ppen` is specified, a “pen expression” is included in the `drawdot` command written to `out_stream`. Otherwise, MetaPost’s `currentpen` is used. If `ddrawdot_color` is specified, the dot will be drawn using that `Color`. Otherwise, the `Color` currently pointed to by the pointer `Colors::default_color` will

be used. This will normally be `Colors::black`. See Chapter 16 [Color Reference], page 87, for more information about `Colors` and the namespace `Colors`.

Please note that the “dot” will always be parallel to the plane of projection. Even where it appears to be a surface, as in Fig. 96, it is never put into perspective, but will always have the same size and shape.

```
Point P(1, 1);
P.drawdot(gray, "pensquare scaled 1cm");
```

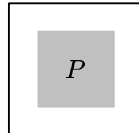

Figure 96.

```
void undrawdot ([string pen = "", [Picture& picture = [Function]
                current_picture]])
void undrawdot ([Picture& picture = current_picture, [string pen [Function]
                = ""]])
```

Undraws a dot on *picture*. If *ppen* is specified, a “pen expression” is included in the `undrawdot` command written to `out_stream`. Otherwise, MetaPost’s `currentpen` is used.

```
Point P(1, 1);
P.drawdot(gray, "pensquare scaled 1cm");
P.undrawdot("pencircle scaled .5cm");
```

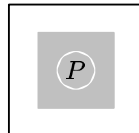

Figure 97.

```
void draw (const Point& p, [const Color& ddraw_color = [Function]
                        *Colors::default_color, [string ddashed = "", [string ppen = "",
                        [Picture& picture = current_picture, [bool aarrow = false]]]])
void draw (Picture& picture = current_picture, const Point& p, [Function]
          [const Color& ddraw_color = *Colors::default_color, [string ddashed =
          "", [string ppen = "", [bool aarrow = false]]]])
```

Draws a line from *\*this* to *p*. Returns the `Path *this -- p1`. See Section 26.12 [Path Reference; Drawing and Filling], page 179, for more information.

```
Point P(-1, -1, -1);
Point Q(2, 3, 5);
P.draw(Q, Colors::gray, "", "pensquare scaled .5cm");
```

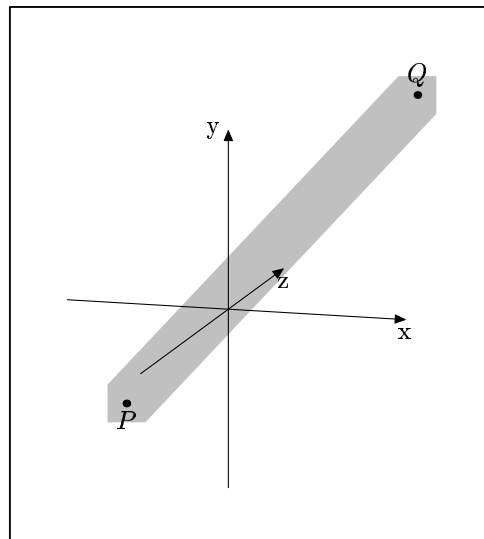

Figure 98.

```
void undraw (const Point& p, [string ddashed = "", [string ppen = [Function]
    "", [Picture& picture = current_picture]]])
```

```
void undraw (Picture& picture, const Point& p, [string ddashed = [Function]
    "", [string ppen = ""]])
```

Undraws a line from *\*this* to *p*. Returns the Path *\*this* -- *p1*. See Section 26.12 [Path Reference; Drawing and Filling], page 179, for more information.

```
Point P(-1, -1, -1);
Point Q(2, 3, 5);
P.draw(Q, Colors::gray, "", "pensquare scaled .5cm");
P.undraw(Q, "evenly scaled 6", "pencircle scaled .3cm");
```

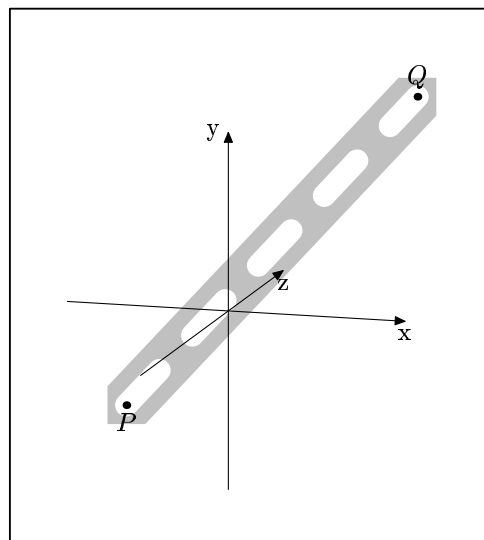

Figure 99.

Path **draw\_help** (const Point& *p*, [const Color& *ddraw\_color* = [Function]  
`*Colors::help_color, [string ddashed = "", [string ppen = "",`  
`[Picture& picture = current_picture]]]])`

Path **draw\_help** (Picture& *picture*, const Point& *p*, [const Color& [Function]  
`ddraw_color = *Colors::help_color, [string ddashed = "", [string ppen`  
`= ""]]]])`

Draws a “help line” from *\*this* to *p*, but only if the static Path data member `do_help_lines` is true. See Section 26.1 [Path Reference; Data Members], page 164.

“Help lines” are lines that are used when constructing a drawing, but that should not be printed in the final version.

Path **drawarrow** (const Point& *p*, [const Color& *ddraw\_color* = [Function]  
`*Colors::default_color, [string ddashed = "", [string ppen = "",`  
`[Picture& picture = current_picture]]]])`

Path **drawarrow** (Picture& *picture*, const Point& *p*, [const Color& [Function]  
`ddraw_color = *Colors::default_color, [string ddashed = "", [string`  
`ppen = ""]]]])`

Draws an arrow from *\*this* to *p* and returns the Path `*this -- p`. The second version is convenient for passing a `Picture` argument without having to specify all of the other arguments.

```
Point P(-3, -2, 1);
Point Q(3, 3, 5);
P.drawarrow(Q);
```

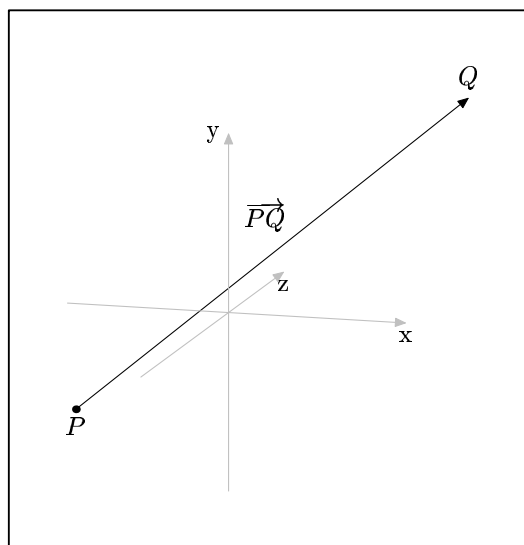

Figure 100.

## 22.19 Labelling

Labels make it possible to include TeX text within a drawing. Labels are implemented by means of class `Label`. The functions `label()` and `dotlabel()`, described in this section, create objects of type `Label`, and add them to the `Picture`, which was passed to them as

an argument (`current_picture`, by default). See Chapter 20 [Label Reference], page 107, for more information.

```
void label (const string text_str, [const string position_str    [const function]
      = "top", [const bool dot = false, [Picture& picture =
      current_picture]]])
void label (const short text_short, [const string                [const function]
      position_str = "top", [const bool dot = false, [Picture& picture =
      current_picture]]])
```

These functions cause a `Point` to be labelled in the drawing. The first argument is the text of the label. It can either be a `string`, in the first version, or a `short`, in the second. It will often be the name of the `Point` in the C++ code, for example, "p0". It is not possible to automate this kind of labelling, because it is not possible to access the names of variables through the variables themselves in C++.

`text_str` is always placed between "b`tex`" and "e`tex`" in the MetaPost `label` command written to `out_stream`. This makes it possible to include math mode material in the text of labels, as in the following example.

```
Point p0(2, 3);
p0.label("$p_0$");
```

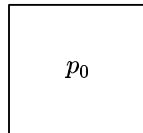

Figure 101.

If backslashes are needed in the text of the label, then `text_str` must contain double backslashes, so that single backslashes will be written to `out_stream`.

```
Point P;
Point Q(2, 2);
Point R(P.mediate(Q));
R.label("$\\overrightarrow{PQ}$", "ulft");
```

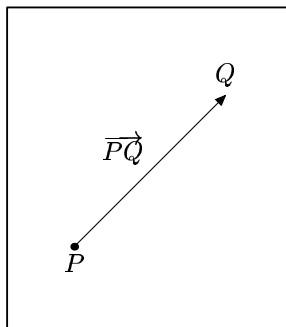

Figure 102.

The `position` argument indicates where the text of the label should be located relative to the `Point`. The valid values are the strings used in MetaPost for this purpose, i.e., 'top', 'bot', 'lft', 'rt', 'llft' (lower left), 'lrt' (lower right), 'ulft' (upper left), and 'urt' (upper right). The default is 'top'. 3DLDF does not catch the error if an

invalid `position` argument is used; the `string` is written to the output file and an error will occur when MetaPost is run.

The `dot` argument is used to determine whether the label should be dotted or not. The default is `false`. The function `dotlabel()` calls `label()`, passing `true` as the latter's `dot` argument.

```
void dotlabel ([const string text_str, [const string          [const function]
               position_str = "top", [Picture& picture = current_picture]])]
void dotlabel (const short text_short, [const string          [const function]
               position_str = "top", [Picture& picture = current_picture]])
```

These functions are like `label()` except that they always produces a dot.

```
Point p0(2, 3);
p0.dotlabel("$p_0$");
```

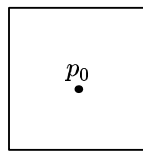

Figure 103.

## 22.20 Showing

```
void show ([string text = "", [char coords = 'w', [const bool      [const function]
               do_persp = true, [const bool do_apply = true, [Focus* f = 0, [const
               unsigned short proj = Projections::persp, [const real factor = 1]]]])])
```

Prints `text` followed by the values of a set of coordinates to standard output (`stdout`). The other arguments are similar to those used in the functions described in Section 22.9 [Returning Coordinates], page 126.

```
Point P(1, 3, 5);
P.rotate(15, 67, 98);
P.show("P:");
-| P: (-3.68621, -3.89112, 2.50421)
```

```
void show_transform ([string text = ""]) [Function]
Prints text to standard output (stdout), or "transform:", if text is the empty string (the default), and then calls transform.show().
```

```
Point A(-1, 1, 1);
Point B(13, 12, 6);
Point Q(31, 17.31, 6);
Q.rotate(A, B, 32);
Q.show_transform("Q.transform:");
-| Q.transform:
   Transform:
     0.935  0.212 -0.284    0
    -0.0749 0.902  0.426    0
     0.346 -0.377  0.859    0
    -0.336 0.687 -0.569    1
```



## 22.21 Outputting

- ostream& operator<<** (ostream& o, Point& p) [Non-member function]  
 Used in `Path::output()` for writing the x and y values of the `projective_coordinates` of `Points` to `out_stream`. See Section 26.16 [Path Reference; Outputting], page 196. This is a low-level function that ordinary users should never have to invoke directly.
- void output** (void) [Function]  
 Writes the MetaPost code for drawing or undrawing a `Point` to `out_stream`. Called by `Picture::output()`, when a `Shape` on the `Picture` is a `Point`. See Section 21.8 [Picture Reference; Outputting], page 113.
- void suppress\_output** (void) [Virtual function]  
 Sets `do_output` to `false`, which causes a `Point` not to be output. This function is called in `Picture::output()`, when a `Point` cannot be projected. See Section 21.8 [Picture Reference; Outputting], page 113.
- virtual void unsuppress\_output** (void) [Virtual function]  
 Resets `do_output` to `true`, so that a `Point` can potentially be output, if `Picture::output()` is called again for the `Picture` the `Point` is on. This function is called in `Picture::output()`. See Section 21.8 [Picture Reference; Outputting], page 113.
- vector<shape\*> extract** (const Focus& f, const unsigned short proj, real factor) [Function]  
 Attempts to project the `Point` using the arguments passed to `Picture::output()`, which calls this function. If `extract()` succeeds, it returns a `vector<shape*>` containing only the `Point`. Otherwise, it returns an empty `vector<shape*>`.
- bool set\_extremes** (void) [Virtual function]  
 Sets “extreme” values for x, y, and z in `projective_coordinates`. This is, of course, trivial for `Points`, because they only have one x, y and z-coordinate. So the maxima and minima for each coordinate are always the same.
- valarray <real> get\_extremes** (void) [Virtual inline const function]  
 Returns `projective_extremes`.
- real get\_minimum\_z** (void) [Virtual const function]  
**real get\_maximum\_z** (void) [Virtual const function]  
**real get\_mean\_z** (void) [Virtual const function]  
 These functions return the minimum, maximum, and mean z-value of the `Point`. `get_minimum_z()` returns `projective_extremes[4]`, `get_maximum_z()` returns `projective_extremes[5]`, and `get_mean_z()` returns `(projective_extremes[4] + projective_extremes[5]) / 2`. However, since a `Point` has only one z-coordinate (from `world_coordinates`), these values will all be the same.
- These functions are pure virtual functions in `Shape`, and are called on `Points` through pointers to `Shape`. Therefore, they must be consistent with the versions for other types derived from `Shape`. See Section 18.10 [Outputting Shapes], page 94.

## 23 Focus Reference

Class `Focus` is defined in `'points.web'`. `Focuses` are used when creating a perspective projection. They represent the center of projection and can be thought of like a camera viewing the scene.

### 23.1 Data Members

**Point position** [Private variable]  
The location of the `Focus` in the world coordinate system.

**Point direction** [Private variable]  
The direction of view from `position` into the scene.

**Point up** [Private variable]  
The direction that will be at the top of the projected drawing.

**real distance** [Private variable]  
The distance of the `Focus` from the plane of projection.

**real angle** [Private variable]  
Used for determining the `up` direction.

**char axis** [Private variable]  
The main axis onto which the `Focus` is transformed in order to perform the perspective projection, `z` by default.  
It will normally not matter which axis is used, but it might be advantageous to use a particular axis in some special situations.

**Transform transform** [Private variable]  
The `Transform`, which will be applied to the `Shapes` on the `Picture`, when the latter is output. The effect of this is equivalent to transforming the `Focus`, so that it lies on a major axis.

```
Focus f(5, 5, -10, 2, 4, 10, 10, 180);
⇒
```

$$f.\text{transform} \equiv \begin{pmatrix} 0.989 & -0.00733 & -0.148 & 0 \\ 0 & 0.999 & -0.0494 & 0 \\ 0.148 & 0.0488 & 0.988 & 0 \\ -3.46 & -4.47 & 0.865 & 1 \end{pmatrix}$$

**Transform persp** [Private variable]  
The `Transform` representing the perspective transformation for a particular `Focus`. Let  $d$  stand for `distance`, then

$$\text{persp} \equiv \begin{pmatrix} 1 & 0 & 0 & 0 \\ 0 & 1 & 0 & 0 \\ 0 & 0 & 0 & 1/d \\ 0 & 0 & 0 & 1 \end{pmatrix}$$

## 23.2 Global Variables

**Focus default\_focus** [Variable]

Effectively, the default `Focus` in `Picture::output()`. See Section 21.8.2 [Picture Reference; Outputting; Functions], page 114. It's not really the default, but the version of `output()` that doesn't take a `Focus` argument calls another version that does take one, passing `default_focus` to the latter as its `Focus` argument.

It's necessary to do this in such a roundabout way, because `Picture::output()` must be declared before `class Focus` is completely defined and `default_focus` is declared.

The declaration `'Focus& f = default_focus;'` makes `f` a reference to `default_focus`, i.e., it makes `f` another name for `default_focus`. This may be convenient, if you don't feel like typing `default_focus`.

## 23.3 Constructors and Setting Functions

`void Focus (void)` [Default constructor]

Creates an empty `Focus`

`void Focus (const real pos_x, const real pos_y, const real` [Constructor]

`pos_z, const real dir_x, const real dir_y, const real dir_z, const real dist, [const real ang = 0, [char ax = 'z']]`)

Constructs a `Focus` using the first three `real` arguments as the `x`, `y`, and `z`-coordinates of `position`, and the fourth through the sixth argument as the `x`, `y`, and `z`-coordinates of `direction`. `dist` specifies the distance of the `Focus` from the plane of projection, `ang` the angle of rotation, which affects which direction is considered to be “up”, and `ax` the major axis to which the `Focus` is aligned.

`void set (const real pos_x, const real pos_y, const real` [Setting function]

`pos_z, const real dir_x, const real dir_y, const real dir_z, const real dist, [const real ang = 0, [char ax = 'z']]`)

Resets an existing `Focus`. Corresponds to the constructor above.

`void Focus (const Point& pos, const Point& dir, const real` [Constructor]

`dist, [const real ang = 0, [char ax = 'z']]`)

Constructs a `Focus` using `Point` arguments for `position` and `direction`. Otherwise, the arguments of this constructor correspond to those of the one above.

`void set (const Point& pos, const Point& dir, const real` [Setting function]

`dist, [const real ang = 0, [char ax = 'z']]`)

Resets an existing `Focus`. Corresponds to the constructor above.

## 23.4 Operators

`const Focus& operator= (const Focus& f)` [Assignment operator]

Sets the `Focus` to `f`.

## 23.5 Modifying

`void reset_angle (const real ang)` [Function]  
 Resets the value of `angle` and recalculates the Transforms `transform` and `persp`.

## 23.6 Querying

`const Point& get_position (void)` [Inline const function]  
 Returns position.

`const Point& get_direction (void)` [Inline const function]  
 Returns direction.

`const real& get_distance (void)` [Inline const function]  
 Returns distance.

`const Point& get_up (void)` [Inline const function]  
 Returns up.

`const Transform& get_transform (void)` [Inline const function]  
 Returns transform.

`const real& get_transform_element (const unsigned int row, const unsigned int column)` [Inline const function]  
 Returns an element of transform, given two unsigned ints for the row and the column.

`const Transform& get_persp (void)` [Inline const function]  
 Returns `persp`.

`const real& get_persp_element (const unsigned int row, const unsigned int column)` [Inline const function]  
 Returns an element of `persp`, given two unsigned ints for the row and the column.

## 23.7 Showing

`void show ([const string text_str = "Focus:", [const bool show_transforms = false]])` [const function]  
 Prints `text_str` to standard output (`stdout`), then calls `Point::show()` on `position`, `direction`, and `up`. Then the values of `distance`, `axis`, and `angle` are printed to `stdout`. If `show_transforms` is true, `transform` and `persp` are shown as well.

## 24 Line Reference

The `struct Line` is defined in `'lines.web'`. Lines are not `Shapes`. They are used for performing vector operations. A `Line` is defined by a `Point` representing a position vector and a `Point` representing a direction vector.

See also the descriptions of `Point::get_line()` in Section 22.16 [Points and Lines], page 139, and `Path::get_line()` in Section 26.15 [Path Reference; Querying], page 193.

### 24.1 Data Members

`Point position` [Public variable]  
Represents the position vector of the `Line`.

`Point direction` [Public variable]  
Represents the direction vector of the `Line`.

### 24.2 Global Constants

`const Line INVALID_LINE` [Constant]  
position and direction are both `INVALID_POINT`.

### 24.3 Constructors

`void Line (const Point& pos = origin, const Point& dir = origin)` [Default constructor]  
Creates a `Line`, setting `position` to `pos`, and `direction` to `dir`. If this function is called with no arguments, it creates a `Line` at the `origin` with no direction.

```
Point p(2, 1, 2);
Point d(-3, 3, 3.5);
Line L0(p, d);
Line L1 = p.get_line(d);
```

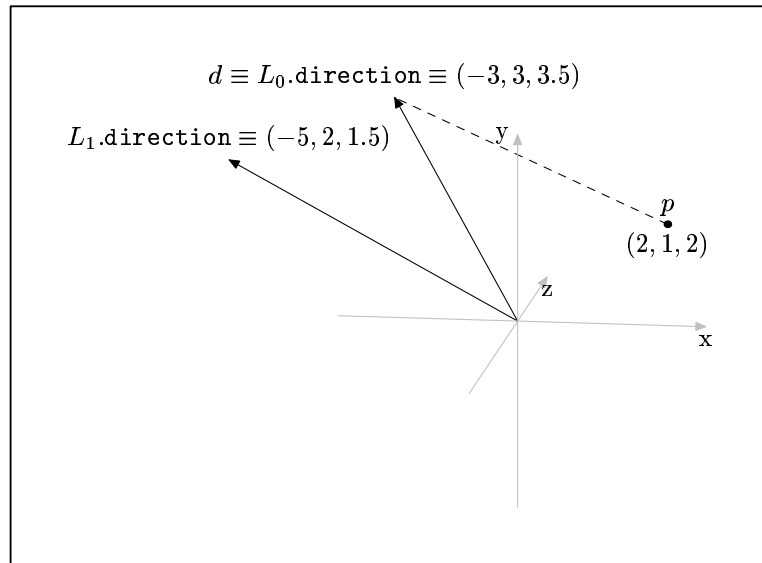

Figure 104.

`void Line (const Line& l)` [Copy constructor]  
Creates a Line, making it a copy of  $l$ .

## 24.4 Operators

`void operator= (const Line& l)` [Assignment operator]  
Sets  $*this$  to  $l$ .

## 24.5 Get Path

`Path get_path (void)` [const function]  
Returns a linear Path with two Points on the Line. The first Point will be `position`, and the second will be `position + direction`.

## 24.6 Showing

`void show ([string text = ""])` [Function]  
If  $text$  is not the empty string (the default), it is printed on a line of its own to standard output. Otherwise, 'Line:' is printed. Following this, `Point::show()` is called on `position` and `direction`.

```
Point p(1, -2, 3);
Point d(-12.3, 21, 36.002);
Line L0(p, d);
L0.show("L0:");
└ L0:
  position: (1, -2, 3)
  direction: (-12.3, 21, 36.002)
Line L1 = p.get_line(d);
L1.show("L1:");
```

```
└─ L1:
    position: (1, -2, 3)
    direction: (-13.3, 23, 33.002)
Path q = L1.get_path();
q.show("q:");
└─ q:
    fill_draw_value == 0
    (1, -2, 3) -- (-12.3, 21, 36.002);
```

## 25 Plane Reference

The `struct Plane` is defined in `'planes.web'`. `Planes` are not `Shapes`. They are used for performing vector operations. A `Plane` is defined by a `Point` representing a point on the plane, a `Point` representing the normal to the plane, and the distance of the plane from the origin.

The most common use of `Planes` is to represent the plane in which an existing plane figure lies. Therefore, they most likely to be created by using `Path::get_plane()`. See Section 26.15 [Path Reference; Querying], page 193. However, `class Plane` does have constructors for creating `Planes` directly, if desired. See Section 25.3 [Planes Reference; Constructors], page 156.

### 25.1 Data Members

Because the main purpose of `Plane` is to provide information about `Shapes`, its data members are all `public`.

|                                            |                   |
|--------------------------------------------|-------------------|
| <code>Point point</code>                   | [Public variable] |
| Represents a point on the plane.           |                   |
| <code>Point normal</code>                  | [Public variable] |
| Represents the normal to the plane.        |                   |
| <code>real distance</code>                 | [Public variable] |
| The distance of the plane from the origin. |                   |

### 25.2 Global Constants

|                                                                                                                                                                              |            |
|------------------------------------------------------------------------------------------------------------------------------------------------------------------------------|------------|
| <code>const Plane INVALID_PLANE</code>                                                                                                                                       | [Constant] |
| A <code>Plane</code> with <code>point</code> $\equiv$ <code>normal</code> , and <code>distance</code> $\equiv$ <code>INVALID_REAL</code> .                                   |            |
| <code>INVALID_PLANE</code> is returned from <code>Path::get_plane()</code> , if the <code>Path</code> is not planar. See Section 26.15 [Path Reference; Querying], page 193. |            |

### 25.3 Constructors

|                                                                                                                                                                                                                                                                                                                |                       |
|----------------------------------------------------------------------------------------------------------------------------------------------------------------------------------------------------------------------------------------------------------------------------------------------------------------|-----------------------|
| <code>void Plane (void)</code>                                                                                                                                                                                                                                                                                 | [Default constructor] |
| Creates a degenerate <code>Plane</code> with <code>point</code> $\equiv$ <code>normal</code> $\equiv$ <code>origin</code> , and <code>distance</code> $\equiv$ 0.                                                                                                                                              |                       |
| <code>Planes</code> constructed using this constructor will probably be set using the assignment operator or <code>Path::get_plane()</code> immediately, or very soon after being declared. See Section 25.4 [Planes Reference; Operators], page 157, and Section 26.15 [Paths Reference; Querying], page 193. |                       |
| <code>void Plane (const Plane&amp; p)</code>                                                                                                                                                                                                                                                                   | [Copy constructor]    |
| Creates a new <code>Plane</code> , making it a copy of <code>p</code> .                                                                                                                                                                                                                                        |                       |



`void Plane (const Point& p, const Point& n)` [Constructor]

If  $p$  is not equal to  $n$ , this constructor creates a `Plane` and sets `point` to  $p$ . `normal` is set to  $n$ , and made a unit vector. `distance` is calculated according to the following formula: Let  $n$  stand for `normal`,  $p$  for `point`, and  $d$  for `distance`:  $d = -p \cdot n$ . If  $d = 0$ , `origin` lies in the `Plane`. If  $d > 0$ , `origin` lies on the side of the `Plane` that `normal` points to, considered to be “outside”. If  $d < 0$ , `origin` lies on the side of the `Plane` that `normal` does not point to, considered to be “inside”.

However, if  $p \equiv n$ , `point` and `normal` are both set to `INVALID_POINT`, and `distance` is set to `INVALID_REAL`, i.e., `*this` will be equal to `INVALID_PLANE` (see Section 25.2 [Planes Reference; Global Constants], page 156).

```
Point P(1, 1, 1);
Point N(0, 1);
N.rotate(-35, 30, 20);
N.show("N:");
├ N: (-0.549659, 0.671664, 0.496732)
Plane q(P, N);
cout << q.distance;
├ -0.618736
```

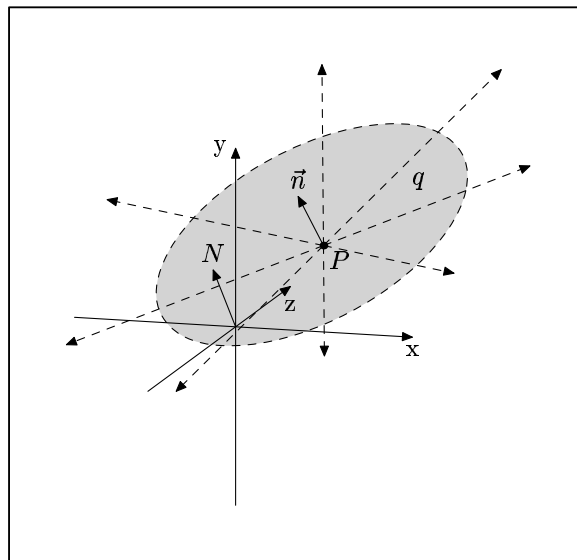

Figure 105.

## 25.4 Operators

`const Plane& operator= (const Plane& p)` [Assignment operator]

Sets `point` to  $p$ .`point`, `normal` to  $p$ .`normal`, and `distance` to  $p$ .`distance`. The return value is  $p$ , so that invocations of this function can be chained.

```
Point pt(2, 2.3, 6);
Point norm(-1, 12, -36);
Plane A(pt, norm);
Plane B;
```

```

Plane C;
B = C = A;
A.show("A:");
-| A:
   normal: (-0.0263432, 0.316118, -0.948354)
   point: (2, 2.3, 6)
   distance == 5.01574
cout << (A == B && A == C && B == C);
-| 1

```

**bool operator==** (const Plane& p) [const operator]  
 Equality operator. Compares *\*this* and *p*, and returns **true**, if *point*  $\equiv$  *p.point*, *normal*  $\equiv$  *p.normal*, and *distance*  $\equiv$  *p.distance*, otherwise **false**.

**bool operator!=** (const Plane& p) [const operator]  
 Inequality operator. Compares *\*this* and *p* and returns **true**, if *point*  $\neq$  *p.point*, or *normal*  $\neq$  *p.normal*, or *distance*  $\neq$  *p.distance*. Otherwise, it returns **false**.

## 25.5 Returning Information

**real\_short get\_distance** (const Point& p) [const function]  
**real\_short get\_distance** (void) [const function]

The version of this function taking a **Point** argument returns a **real\_short** *r*, whose **real** part (*r.first*) represents the distance of *p* from the **Plane**. This value is always positive. *r.second* can take on three values:

- 0            If the **Point** lies in the **Plane**.
- 1            If it lies on the side of the **Plane** pointed at by the normal to the **Plane**, considered to be the “outside”.
- 1           If it lies on the side of the **Plane** *not* pointed at by the normal to the **Plane**, considered to be the “inside”.

The version taking no argument returns the absolute of the data member **distance** and its sign, i.e., the distance of **origin** to the **Plane**, and which side of the **Plane** it lies on.

It would have been possible to use **origin** as the default for an optional **Point** argument, but I’ve chosen to overload this function, because of problems that may arise, when I implement **user\_coordinates** and **view\_coordinates** (see Section 22.1 [Point Reference; Data Members], page 118).

```

Point N(0, 1);
N.rotate(-10, 20, 20);
Point P(1, 1, 1);
Plane q(P, N);
Point A(4, -2, 4);
Point B(-1, 3, 2);
Point C = q.intersection_point(A, B).pt;
real_short bp;

```

```
bp = q.get_distance();  
cout << bp.first;  
+ 0.675646  
cout << bp.second  
+ -1  
  
bp = q.get_distance(A)  
cout << bp.first;  
+ 3.40368  
cout << bp.second;  
+ -1  
  
bp = q.get_distance(B)  
cout << bp.first;  
+ 2.75865  
cout << bp.second;  
+ 1  
  
bp = q.get_distance(C)  
cout << bp.first;  
+ 0  
cout << bp.second;  
+ 0
```

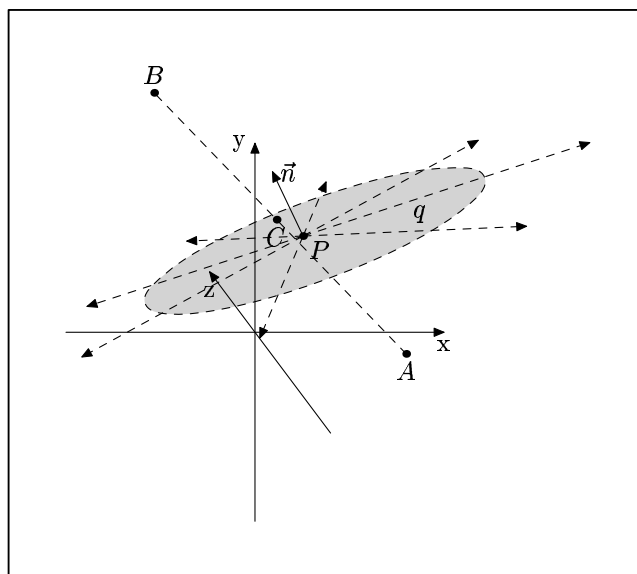

Figure 106.

## 25.6 Intersections

`bool_point intersection_point (const Point& p0, const Point& p1)` [const function]

`bool_point intersection_point (const Path& p)` [const function]

These functions find the intersection point of the `Plane` and a line. In the first version, the line is defined by the two `Point` arguments. In the second version, the `Path` `p` must be linear, i.e., `p.is_linear()` must be `true`.

Both versions of `intersection_point()` return a `bool_point` `bp`, where `bp.pt` is the intersection point, or `INVALID_POINT`, if there is none. If an intersection point is found, `bp.b` will be `true`, otherwise `false`. Returning a `bool_point` makes it possible to test for success without comparing the `Point` returned against `INVALID_POINT`.

```
Point center(2, 2, 3.5);
Reg_Polygon h(center, 6, 4, 80, 30, 10);
Plane q = h.get_plane();
Point P0 = center.mediate(h.get_point(2));
P0.shift(5 * (N - center));
Point P1(P0);
P1.rotate(h.get_point(1), h.get_point(4));
P1 = 3 * (P1 - P0);
P1.shift(P0);
P1.shift(3, -.5, -2);
bool_point bp = q.intersection_point(P0, P1);
Point i_P = bp.pt;
Point P4 = h.get_point(3).mediate(h.get_point(0), .75);
P4.shift(N - center);
Point P5(P4);
P5.rotate(h.get_point(3), h.get_point(0));
P4.shift(-1, 2);
Path theta(P4, P5);
bp = q.intersection_point(theta);
Point i_theta = bp.pt;
draw_axes();
```

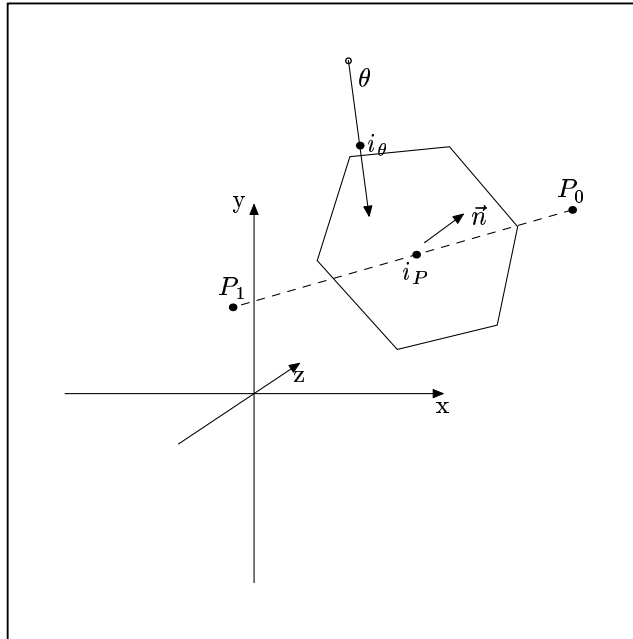

Figure 107.

**Line intersection\_line** (const Plane& p) [const function]  
 Returns a Line *l*. representing the line of intersection of two Planes. See Chapter 24 [Line Reference], page 153.

In Fig. 108, `intersection_line()` is used to find the line of intersection of the Planes derived from the Rectangles  $r_0$  and  $r_1$  using `get_plane()` (see Section 26.15 [Paths Reference; Querying], page 193). Please note that there is no guarantee that `l.position` will be in a convenient place for your drawing. A bit of fiddling was needed to find the Points  $P_2$  and  $P_3$ . I plan to add functions for finding the intersection lines of plane figures, but haven't done so yet.

```

Rectangle r0(origin, 5, 5, 10, 15, 6);
Rectangle r1(origin, 5, 5, 90, 50, 10);
r1 *= r0.rotate(30, 30, 30);
r1 *= r0.shift(1, -1, 3);
Plane q0 = r0.get_plane();
Plane q1 = r1.get_plane();
Line l = q0.intersection_line(q1);
l.show("l:");
└ l:
    position: (0, 11.2193, 20.0759)
    direction: (0.0466595, -0.570146, -0.796753)
Point P0(l.direction);
P0.shift(l.position);
P0.show("P0:");
└ P0: (0.0466595, 10.6491, 19.2791)
Point P1(-l.direction);
P1.shift(l.position);
Point P2(P0 - P1);
P2 *= 12.5;

```

```

P2.shift(P0);
cout << P2.is_on_plane(q0);
+ 1
cout << P2.is_on_plane(q1);
+ 1
Point P3(P0 - P1);
P3 *= 7;
P3.shift(P0);
cout << P3.is_on_plane(q0);
+ 1
cout << P3.is_on_plane(q1);
+ 1

```

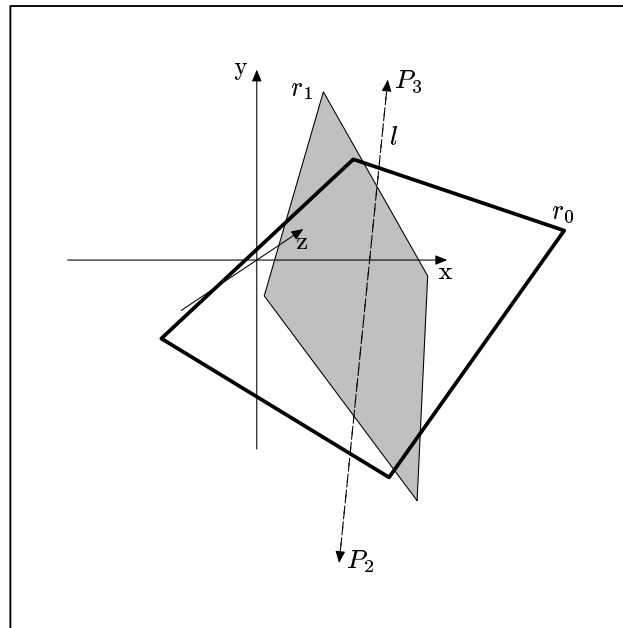

Figure 108.

## 25.7 Showing

```
void show ([string text = ""]) [const function]
```

Prints information about the `Plane` to standard output. If `text` is not the empty `string`, it is printed to the standard output. Otherwise, 'Plane:' is printed. Following this, if the `Plane` is equal to `INVALID_PLANE` (see Section 25.2 [Planes Reference; Global Constants], page 156), a message to this effect is printed to standard output. Otherwise, `normal` and `point` are shown using `Point::show()` (see Section 22.20 [Point Reference; Showing], page 148). Finally, `distance` is printed.

```

Point A(1, 3, 2.5);
Rectangle r0(A, 5, 5, 10, 15, 6);
Plane p = r0.get_plane();
+ p:
  normal: (-0.0582432, 0.984111, -0.167731)

```

```
point: (-0.722481, 2.38245, -0.525176)
distance == -2.47476
```

## 26 Path Reference

Class `Path` is defined in `'paths.web'`. It is derived from `Shape` using `protected` derivation.

### 26.1 Data Members

**bool line\_switch** [Protected variable]  
 true if the `Path` was created using the constructor `Path(const Point& p0, const Point& p1)`, directly or indirectly. See Section 26.2 [Path Reference; Constructors and Setting Functions], page 166.

```

Point p0;
Point p1(1, 1);
Point p2(2, 3);
Path q0(p0, p1);
cout << q0.get_line_switch();
+ 1
Path q1;
q1 = q0;
cout << q1.get_line_switch();
+ 1
Path q2 = p0.draw(p1);
cout << q2.get_line_switch();
+ 1
Path q3("..", false, &p1, &p2, &p0, 0);
cout << q3.get_line_switch();
+ 0

```

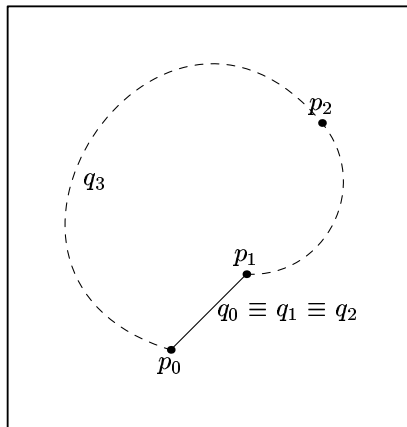

Figure 109.

Some `Path` functions only work on *linear* Paths, so it's necessary to be able to distinguish them from non-linear ones. The function `is_linear()` should be enough to ensure that all of these functions work, so I plan to make `line_switch` obsolete soon. However, at the moment, it's still needed. See Section 26.15 [Path Reference; Querying], page 193.



- bool cycle\_switch** [Protected variable]  
 true if the Path is cyclical, otherwise false.
- bool on\_free\_store** [Protected variable]  
 true if the Path was dynamically allocated on the free store. Otherwise false. Set to true only in `create_new<Path>()`, which should be the only way Paths are ever dynamically allocated. See Section 26.2 [Path Constructors and Setting Functions], page 166.
- bool do\_output** [Protected variable]  
 Used in `Picture::output()`. Set to false if the Path isn't projectable using the arguments passed to `Picture::output()`. See Section 21.8 [Picture Reference; Outputting], page 113.
- signed short fill\_draw\_value** [Protected variable]  
 Set in the drawing and filling functions, and used in `Path::output()`, to determine what MetaPost code to write to `out_stream`. See Section 26.12 [Path Reference; Drawing and Filling], page 179, and Section 26.16 [Path Reference; Outputting], page 196.
- const Color\* draw\_color** [Protected variable]  
 Pointer to the Color used if the Path is drawn.
- const Color\* fill\_color** [Protected variable]  
 Pointer to the Color used if the Path is filled.
- string dashed** [Protected variable]  
 String written to `out_stream` for the “dash pattern” in a MetaPost `draw` or `undraw` command. If and only if `dashed` is not the empty string, “`dashed <dash pattern>`” is written to `out_stream`.  
 Dash patterns have no meaning inside 3DLDF; `dashed`, if non-empty, is written unchanged to `out_stream`. I may change this in the future.
- string pen** [Protected variable]  
 String written to `out_stream` for the `pen` to be used in a MetaPost `draw`, `undraw`, `filldraw`, or `unfilldraw` command. If and only if `pen` is not the empty string, “`withpen <...>`” is written to `out_stream`.  
 Pens have no meaning inside 3DLDF; `pen`, if non-empty, is written unchanged to `out_stream`. I may change this in the future.
- bool arrow** [Protected variable]  
 Indicates whether an arrow should be drawn when outputting a Path. Set to true on a Path created on the free store and put onto a `Picture` by `drawarrow()`.
- valarray<real> projective\_extremes** [Protected variable]  
 Contains the maxima and minima of the x, y, and z-coordinates of the *projections* of Points on a Path using a particular Focus. Set in `set_extremes()` and used in `Picture::output()` for surface hiding.

`vector<Point*> points` [Protected variable]  
 Pointers to the `Points` on the `Path`.

`vector<string> connectors` [Protected variable]  
 The connectors between the `Points` on the `Path`. Connectors are simply `strings` in 3DLDF, they are written unchanged to `out_stream`.

`const Color* help_color` [Public static variable]  
 Pointer to a `const Color`, which becomes the default for `draw_help()`. See Section 26.12 [Path Reference; Drawing and Filling], page 179.

Please note that `help_color` is a pointer to a `const Color`, not a `const` pointer to a `Color` or a `const` pointer to a `const Color`! It's easy to get confused by the syntax for these types of pointers.<sup>1</sup>

`string help_dash_pattern` [Public static variable]  
 The default dash pattern for `draw_help()`.

`bool do_help_lines` [Public static variable]  
`true` if help lines should be output, otherwise `false`. If `false`, a call to `draw_help()` does not cause a copy of the `Path` to be created and put onto a `Picture`. See Section 26.12 [Path Reference; Drawing and Filling], page 179.

## 26.2 Constructors and Setting Functions

`void Path (void)` [Default constructor]  
 Creates an empty `Path` with no `Points` and no connectors.

`void Path (const Point& p0, const Point& p1)` [Constructor]  
 Creates a line (more precisely, a line segment) between `p0` and `p1`. The single connector between the two `Points` is set to `"--"` and the data member `line_switch` (of type `bool`) is set to `true`. There are certain operations on `Paths` that are only applicable to lines, so it's necessary to store the information that a `Path` is a line.<sup>2</sup>

```
Point A(-2, -2.5, -1);
Point B(3, 2, 2.5)
Path p(A, B);
p.show("p:");
├─ p:
   (-2, -2.5, -1) -- (3, 2, 2.5);
```

<sup>1</sup> Stroustrup, *The C++ Programming Language*, p. 96.

<sup>2</sup> It isn't sufficient to check whether a `Path` consists of only two `Points` to determine whether it is a line or not, since a connector with "curl" could cause it to be non-linear. On the other hand, `Paths` containing only colinear `Points` and the connector `"--"` are perfectly legitimate lines. I'm in the process of changing all of the code that tests for linearity by checking the value of `line_switch`, so that it uses `is_linear()` instead. When I've done this, it may be possible to eliminate `line_switch`. See Section 26.1 [Path Reference; Data Members], page 164, and Section 26.15 [Path Reference; Querying], page 193.

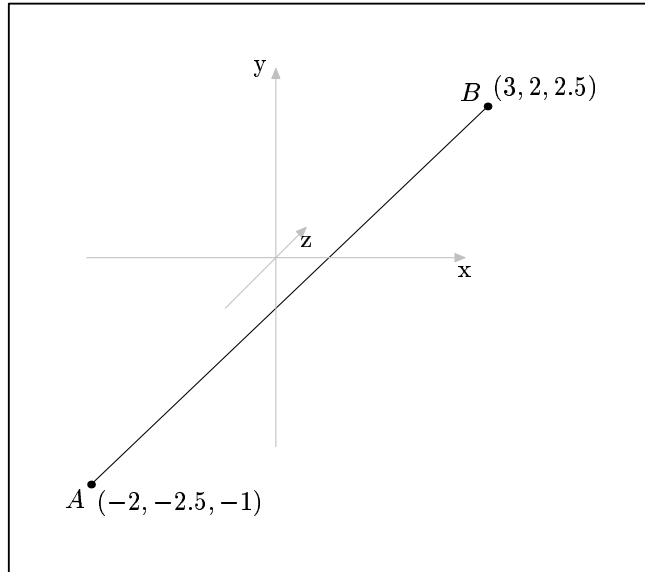

Figure 110.

```
void set (const Point& p0, const Point& p1) [Setting function]
```

Corresponds to the constructor above.

```
Point P0(1, 2, 3);
Point P1(3.5, -12, 75);
Path q;
q.set(P0, P1);
q.show("q:");
└ q:
  (1, 2, 3) -- (3.5, -12, 75);
```

```
void Path (string connector, bool cycle, Point* p, [...], 0) [Constructor]
```

For Paths with an arbitrary number of Points and one type of connector.

*connector* is passed unchanged to *out\_file*, so it must be a valid connector in MetaPost.

*cycle* indicates whether the Path is a cycle or not. *cycle\_switch* is set to *cycle*. See Section 26.1 [Path Reference; Data Members], page 164. The filling and unfilling functions only work for Paths that are cycles. See Section 26.12 [Path Reference; Drawing and Filling], page 179. If a Path is a cycle, it is up to the user to make sure that it has sensible Point and connector values; 3DLDF doesn't check them. If they are not sensible, for instance, if the Path crosses itself, and you try to fill it, this will cause an error in MetaPost. It is possible that a Path will be "sensible" in some projections and not in others, although I have not tested this.

*p* is a pointer to the first Point that should go onto the Path. The ellipsis points (...) represent an arbitrary number of pointers to Points that should go onto the Path. The final argument must be 0, which is interpreted by the C++ compiler as the null pointer.<sup>3</sup>

It is admittedly a bit awkward to have to type "&p0" rather than "p0", and I have frequently forgotten to do it, which causes a compiler error, but all of the arguments

<sup>3</sup> Stroustrup, *The C++ Programming Language*, p. 88.

must be pointers in order to be able to use 0 to indicate the end of the argument list. Convenience in typing function calls is not a high priority in 3DLDF, because once I've written an input routine, these function calls should be generated automatically. It will be more important to define a convenient syntax for the input routine.

```
Point P0;
Point P1(2);
Point P2(2,2);
Point P3(0,2);
Path p("...", true, &P0, &P1, &P2, &P3, 0);
p.draw();
```

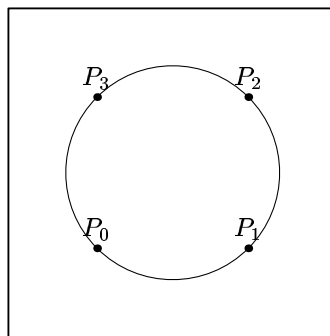

Figure 111.

```
void set (string connector, bool cycle, Point* p, [...], 0) [Setting function]
Corresponds to the constructor above.
```

```
Point P[4];
P[0].set(2, 1, 3);
P[3] = P[2] = P[1] = P[0];
P[3] *= P[2] *= P[1].rotate(3, 12, 18);
P[3] *= P[2].shift(-2, -1, 3);
P[3].shear(1.5, .5, 3.5);
Path q("...", false, &P[0], &P[1], &P[2], &P[3], 0);
q.show("q:");
┌ q:
  (2, 1, 3) ... (0.92139, 1.51449, 3.29505) ...
  (-1.07861, 0.514487, 6.29505) ... (2.84065, -3.26065, 6.29505);
```

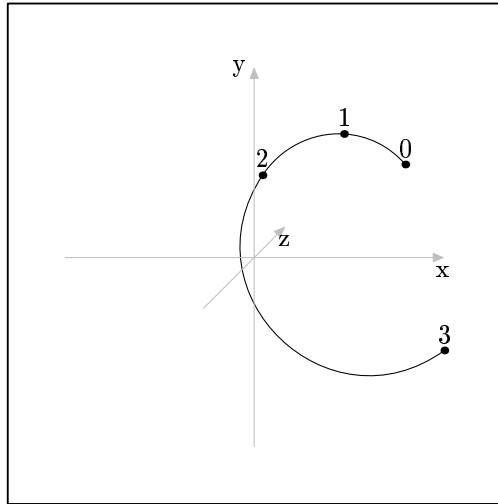

Figure 112.

`void Path (Point* first_point_ptr, char* s, Point* p, [...], 0)` [Constructor]

Constructor for Paths with an arbitrary number of Points and connectors. The first, required, argument is a pointer to a Point, followed by pointers to char alternating with pointers to Points.<sup>4</sup> The last argument must be 0, i.e., the null pointer.

There is no need to indicate by means of an argument whether the Path is a cycle or not: If it is, the last argument before the 0 will be a char\* (pointer to char), if not, it will be a Point\*. The data member `cycle_switch` (of type `bool`) will be set to `true` or `false` accordingly.

```
Point A;
Point B(2, 0);
Point C(3, 2);
Point D(1, 3);
Path p(&A, "..", &B, "..", &C, "--", &D, "...", 0);
```

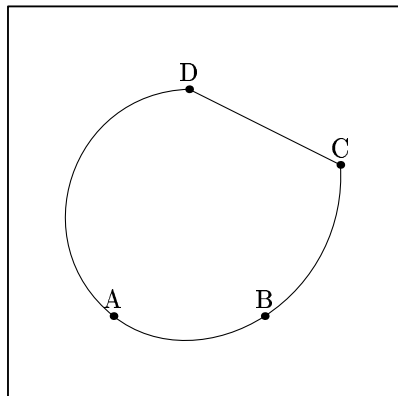

Figure 113.

`void set (Point *first_point_ptr, string s, Point *p, [...], 0)` [Setting function]

Corresponds to the constructor above.

<sup>4</sup> Where possible, I prefer to use the C++ data type `string` rather than `char*`, however it was necessary to use `char*` here because 0 is not a valid `string`, even though `string` may be implemented as `char*`, and 0 must be a valid argument, since it is needed to indicate the end of the argument list.

**void Path** (const Path& *p*) [Copy constructor]  
 Creates a new Path, making it a copy of *p*.

**Path\* create\_new<Path>** (const Path\* *p*) [Template specializations]  
**Path\* create\_new<Path>** (const Path& *p*)

Pseudo-constructors for dynamic allocation of Paths. They create a Path on the free store and allocate memory for it using `new(Path)`. They return a pointer to the new Path.

If *p* is a non-zero pointer or a reference, the new Path will be a copy of *p*. If the new object is not meant to be a copy of an existing one, '0' must be passed to `create_new<Path>()` as its argument. See Chapter 14 [Dynamic Allocation of Shapes], page 83, for more information.

`create_new<Path>()` is used in the drawing and filling functions for copying a Path and putting the copy onto a Picture. See Section 26.12 [Path Reference; Drawing and Filling], page 179.

## 26.3 Destructor

**void ~Path** (void) [virtual Destructor]

All of the Points on a Path are created by `create_new<Point>()`, which allocates them dynamically on the free store. Therefore, the destructor calls `delete()` on all of the pointers on `points`. Following this, it calls `points.clear()` and `connectors.clear()`. `draw_color` and `fill_color` may or may not have been allocated on the free store, so `~Path()` checks this first, and deletes them, if they were. Then, it sets them to 0.

## 26.4 Operators

**Transform operator\*=** (const Transform& *t*) [Virtual function]

Calls `Point::operator*=(t)` on each of the Points on the Path. See Section 22.6 [Point Reference; Operators], page 123. This has the effect of transforming the entire Path by *t*. Please note that Path does not have a `transform` data member of its own.

**void operator+=** (const Point& *pt*) [Function]

Copies *pt* and pushes a pointer to the copy onto `points`. The last connector in the Path will be used to connect the new Point and the previous one.

```
Point A(1, 2, 3);
Point B(3, 4, 5);
Path q;
q += A;
q += B;
q.show("q:");
┌ q:
  (1, 2, 3) -- (3, 4, 5);
```

**Path operator+** (`const Point& pt`) [const function]  
 Copies the `Path` and `pt`, and pushes a pointer to the copy of `pt` onto `points` in the new `Path`. The last connector in the new `Path` will be used to connect the new `Point` and the previous one. The `Path` remains unchanged.

**void operator&=** (`const Path& pa`) [Function]  
 Concatenates two `Paths`. The result is assigned to `*this`. Neither `*this` nor `pa` may be cyclical, i.e., `cycle_switch` must be `false` for both `Paths`.

**Path operator&** (`const Path& pa`) [const function]  
 Returns a `Path` representing the concatenation of `*this` and `pa`. `*this` remains unchanged. Neither `*this` nor `pa` may be cyclical, i.e., `cycle_switch` must be `false` for both `Paths`.

**void operator+=** (`const string s`) [Function]  
 Pushes `s` onto `connectors`.

## 26.5 Appending

**Path append** (`const Path& pa`, [`string connector = "--`", [`bool assign = true`]]) [Function]  
 Appends `pa` to `*this` using `connector` to join them and returns the resulting `Path`. If `assign`  $\equiv$  `true`, then the return value is assigned to `*this`, otherwise, `*this` remains unchanged.

If necessary, a `const` version could be added, for `const Paths`.

```

Point A(-2, 2);
Point B(-2, -2);
Point C(2, -2);
Point D(2, 2);
Path q("--", false, &A, &B, &C, &D, 0);
Point E(1, 2);
Point F(0, 4);
Point G(-.5, 3);
Path r("..", false, &E, &F, &G, 0);
q.append(r, "..", true);
q += "..";
q += "--";
q.set_cycle();
q.show("q:");
└─ q:
  (-2, 2, 0) -- (-2, -2, 0) --
  (2, -2, 0) -- (2, 2, 0) ..
  (1, 2, 0) .. (0, 4, 0) ..
  (-0.5, 3, 0) -- cycle;
```

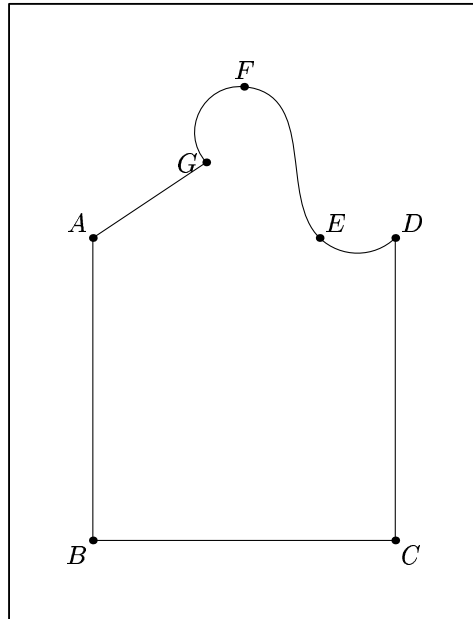

Figure 114.

## 26.6 Copying

**Shape\* get\_copy (void)** [const virtual function]

Creates a copy of the `Path` using `create_new<Path>()`, which returns a pointer to `Path`. `get_copy()` then casts this pointer to a pointer to `Shape` and returns it.

This function is used when copying `Pictures` and in `Solid::output()`, where objects of types derived from `Shape` must be handled in the same way, without their actual types being known.

## 26.7 Clearing

**void clear (void)** [Virtual function]

Does the same thing the destructor `~Path()` does: Calls `delete()` on the pointers to `Points` on `points`, clears `points` and `connectors`, deletes `draw_color` and `fill_color`, if they point to `Colors` that were allocated on the free store, and sets them to 0.

`clear()` is a pure virtual function in `class Shape`, so `Path` must have a `clear()` function. It is needed, because it is sometimes called through a pointer to `Shape`, so that `~Path()` cannot be accessed. At least, so far I haven't found a way to call a destructor through the virtual function facility.

## 26.8 Modifying

**bool set\_on\_free\_store ([bool b = true])** [Virtual function]

Sets `on_free_store` to `b`. This is used in the template function `create_new()`. See Section 26.2 [Path Reference; Constructors and Setting Functions], page 166.



`void set_fill_draw_value (const signed short s)` [Virtual function]  
 Sets `fill_draw_value` to `s`, which should be one of `Shape::DRAW`, `Shape::FILL`, `Shape::FILLDRAW`, `Shape::UNDRAW`, `Shape::UNFILL`, or `Shape::UNFILLDRAW`.

`void set_draw_color (const Color& c)` [Virtual function]  
`void set_draw_color (const Color * c)` [Virtual function]  
 Sets `draw_color` (a pointer to a `const Color`) to `&c` or `c`, depending on whether the version with a reference argument or the version with a pointer argument is used.  
`set_draw_color()` is used in the `Solid` drawing and filling functions, because `Path::draw_color` is `protected`, and the `Solid` cannot access it directly. See Section 34.13 [Solid Reference; Drawing and Filling], page 254.

`void set_fill_color (const Color& c)` [Virtual function]  
`void set_fill_color (const Color* c)` [Virtual function]  
 Sets `fill_color` (a pointer to a `const Color`) to `&c` or `c`, depending on whether the version with a reference argument or the version with a pointer argument is used.  
`set_fill_color()` is used in the `Solid` drawing and filling functions, because `Path::fill_color` is `protected`, and the `Solid` cannot access it directly. See Section 34.13 [Solid Reference; Drawing and Filling], page 254.

`void set_dash_pattern ([const string s = ""])` [Virtual function]  
 Sets dashed to `s`.

`void set_pen ([const string s = ""])` [Virtual function]  
 Sets pen to `s`.

`void set_connectors ([const string s = ". ."])` [Virtual function]  
 Clears `connectors` and then pushes `s` onto it, making `s` the only connector. Additional connectors can be added by using `Path::operator+=(const string)`. See Section 26.4 [Path Reference; Operators], page 170.  
 I plan to add a version of this function taking a vector of `strings` as its argument, to make it possible to set several connectors at one time.

## 26.9 Affine Transformations

`Transform rotate (const real x, [const real y = 0, [const real z = 0]])` [Virtual function]  
 Creates a `Transform t` locally and calls `t.rotate(x, y, z)`. `t` is then applied to all of the `Points` on `points`. The return value is `t`.

`Transform scale (real x, [real y = 1, [real z = 1]])` [Function]  
 Creates a `Transform t` locally and calls `t.scale(x, y, z)`. `t` is then applied to all of the `Points` on `points`. The return value is `t`.

The `Points` on the `Path` are scaled according to the arguments:

```
Point pt[8];
pt[0] = (-1, -1);
for (int i = 1; i < 8; ++i)
```

```

    {
        pt[i] = pt[0];
        pt[i].rotate(0, 0, i * 45);
    }
    Path p("--", true, &pt[0], &pt[1], &pt[2], &pt[3],
           &pt[4], &pt[5], &pt[6],
           &pt[7], 0);
    p.draw();
    p.scale(2, 2);
    p.draw();

```

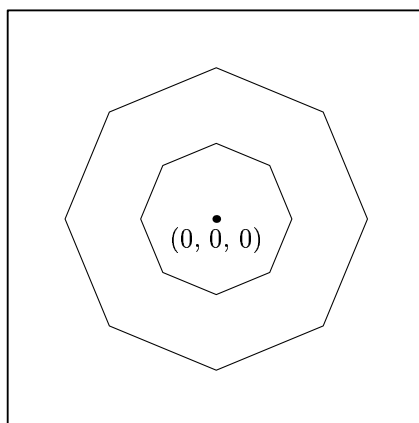

Figure 115.

Transform **shear** (real xy, [real xz = 0, [real yx = 0, [real yz = 0, [Function]  
[real zx = 0, [real zy = 0]]]])

Creates a Transform **t** locally and calls **t.shear(xy, xz, yx, yz, zx, zy)**. **t** is then applied to all of the Points on **points**. The return value is **t**.

```

Point p0;
Point p1(1);
Point p2(1, 1);
Point p3(0, 1);
Path q("--", true, &p0, &p1, &p2, &p3, 0);
q.rotate(0, 45);
q.shift(1);
q.filldraw(black, light_gray);
q.shear(1.5, 2, 2.5, 3, 3.5, 5);
q.filldraw(black, light_gray);

```

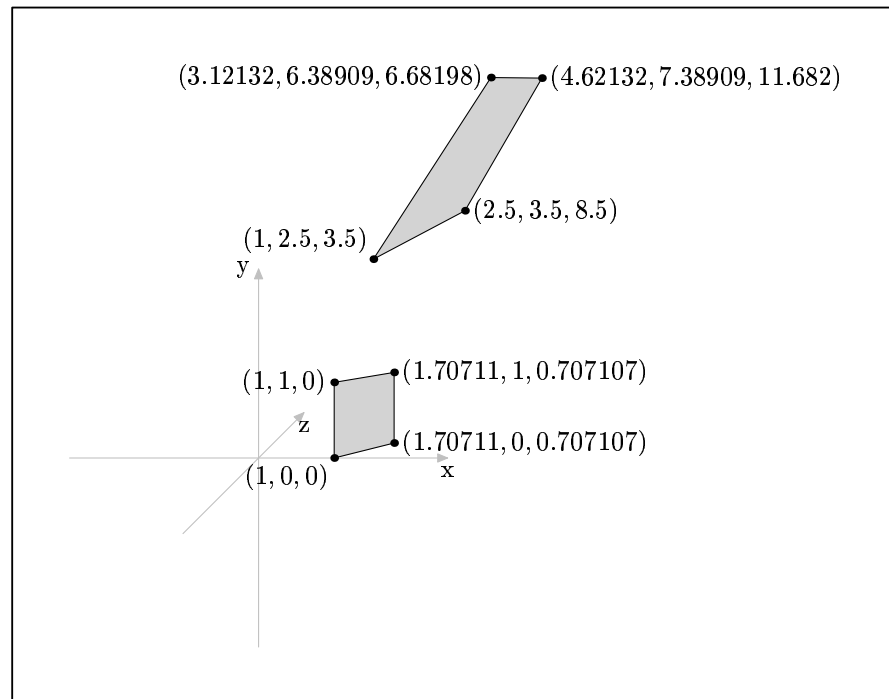

Figure 116.

**Transform shift** (real  $x$ , [real  $y = 0$ , [real  $z = 0$ ]]) [Function]  
 Creates a **Transform**  $t$  locally and calls  $t.shift(x, y, z)$ .  $t$  is then applied to all of the **Points** on **points**. The return value is  $t$ .

Shifts each of the **Points** on the **Path** according to the arguments.

```
default_focus.set(5, 10, -10, 0, 10, 10, 10);
Point pt[6];
pt[0].set(-2, -2);
pt[1].set(0, -3);
pt[2].set(2, -2);
pt[3].set(2, 2);
pt[4].set(0, 3);
pt[5].set(-2, 2);
Path p("--", true, &pt[0], &pt[1], &pt[2],
        &pt[3], &pt[4], &pt[5], 0);
p.draw();
p.shift(3, 3, 3);
p.draw();
```

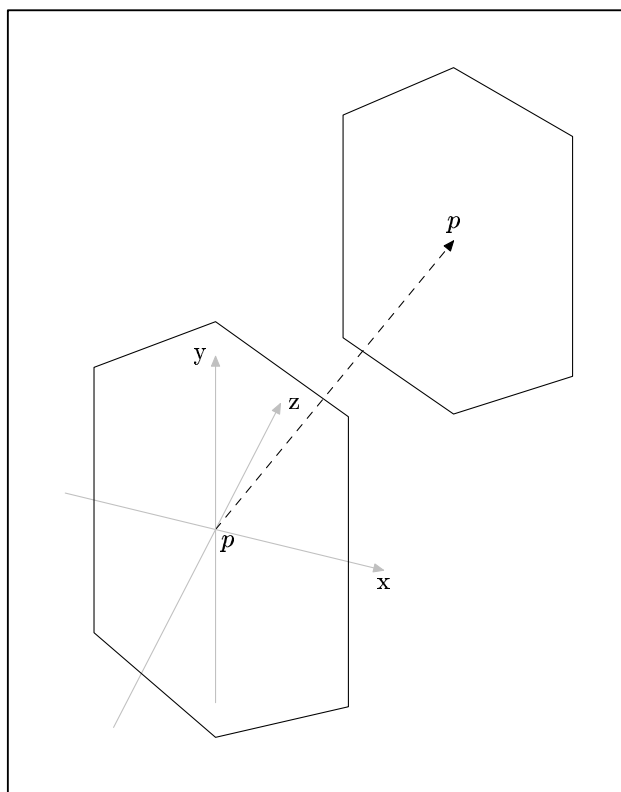

Figure 117.

Transform **shift** (const Point& p) [Function]

Creates a Transform *t* locally and calls *t.shift(p)*. *t* is then applied to all of the Points on points. The return value is *t*.

This version of `shift()` uses the *x*, *y*, and *z*-coordinates of the Point *p* to shift the Path.

```
default_focus.set(5, 10, -10, 0, 10, 10, 10);
Point pt[6];
pt[0].set(-2, -2);
pt[1].set(0, -3);
pt[2].set(2, -2);
pt[3].set(2, 2);
pt[4].set(0, 3);
pt[5].set(-2, 2);
Path p("--", true, &pt[0], &pt[1], &pt[2],
        &pt[3], &pt[4], &pt[5], 0);
p.draw();
Point s(1, 1, 1);
p.shift(s);
p.draw();
```

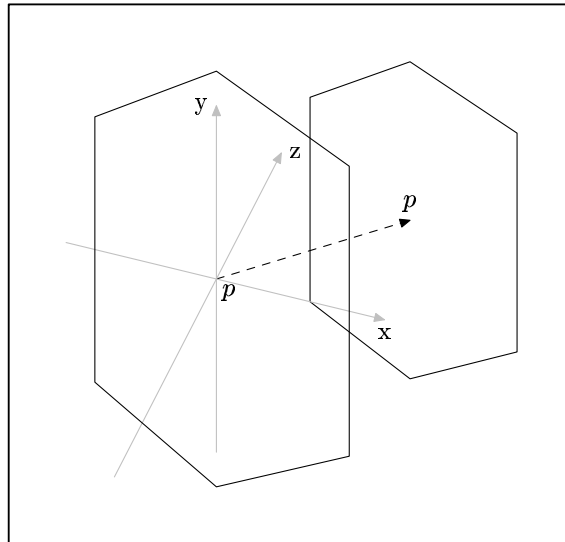

Figure 118.

`void shift_times (real x, [real y = 1, [real z = 1]])` [Virtual function]

`void shift_times (const Point& p)` [Virtual function]

Each of these functions calls the corresponding version of `Point::shift_times()` on all of the `Points` on `points`. See Section 22.12 [Point Reference; Affine Transformations], page 129. The return value is `void`, because there is no guarantee that all of the `Points` on a `Path` will have identical `transform` members (although it's likely).

Please note that `shift_times()` will only have an effect on the `Points` on a `Path` if it's called *after* a call to `shift()` and *before* an operation is applied that causes `Point::apply_transform()` to be called.

`Transform rotate (const Point& p0, const Point& p1, [const real angle = 180])` [Virtual function]

Creates a `Transform t` locally and calls `t.rotate(p0, p1, angle)`. `t` is then applied to all of the `Points` on `points`. The return value is `t`.

`Transform rotate (const Path& p, [const real angle = 180])` [Function]

If `p.is_linear()` returns `true`, this function creates a `Transform t` locally and calls `t.rotate(p, angle)`. `t` is then applied to all of the `Points` on `points`. The return value is `t`. Otherwise, it issues an error message and returns `INVALID_TRANSFORM`.

## 26.10 Aligning with an Axis

`Transform align_with_axis ([const char axis = 'z'])` [const function]

`Transform align_with_axis (bool assign, [const char axis = 'z'])` [Function]

`Transform align_with_axis (const Point& p0, const Point& p1, const char axis)` [Function]

These functions return the `Transform` which, if applied to the `Path`, would align it with the major axis indicated by the `axis` argument.

The first and second versions can only be called for `Paths` where `line_switch` is `true`. The first version is `const`, so the `Path` remains unchanged. The second version should only be called with `assign = true`, so that the `Transform` is applied to the

`Path`, actually aligning it with the axis indicated. If the second version is called with `assign = false`, a warning message is issued to the standard error output (`stderr`), since one might as well use the first version in this case, but it won't do any harm. The third version creates a `Transform` `t` locally that would align the line from `p0` to `p1` with the axis indicated, and applies `t` to the `Path`.

```

Point A(2, 3, 2);
Point B(-1, 1, 3);
Path p(A, B);
Transform t = p.align_with_axis(true, 'z');
t.show("t:");
└─ t:
    -0.316  0.507  -0.802    0
         0  -0.845  -0.535    0
    -0.949  -0.169  0.267    0
         2.53   1.86   2.67    1
p *= t;
p.show("p:");
└─ p:
    (2.53, 1.86, 2.67) -- (-1.02, 1.23, 3.67);

Point C(1);
C *= t.inverse();

Path q;
q += "..";
q += C;

for (int i = 0; i < 15; ++i)
    {
        C.rotate(A, B, 360.0/16);
        q += C;
    }
q.set_cycle(true);
q.show("q:");
└─ q:
    (1.68, 3, 1.05) .. (1.9, 2.68, 1.06) ..
    (2.13, 2.4, 1.21) .. (2.35, 2.22, 1.48) ..
    (2.51, 2.15, 1.83) .. (2.59, 2.22, 2.21) ..
    (2.58, 2.4, 2.55) .. (2.49, 2.68, 2.81) ..
    (2.32, 3, 2.95) .. (2.1, 3.32, 2.94) ..
    (1.87, 3.6, 2.79) .. (1.65, 3.78, 2.52) ..
    (1.49, 3.85, 2.17) .. (1.41, 3.78, 1.79) ..
    (1.42, 3.6, 1.45) .. (1.51, 3.32, 1.19) .. cycle;
q.align_with_axis(A, B, 'z');
q.show("q:");
└─ q:

```

```

(1, 0, 0) .. (0.924, 0.383, 0) ..
(0.707, 0.707, 0) .. (0.383, 0.924, 0) ..
(0, 1, 0) .. (-0.383, 0.924, 0) ..
(-0.707, 0.707, 0) .. (-0.924, 0.383, 0) ..
(-1, 0, 0) .. (-0.924, -0.383, 0) ..
(-0.707, -0.707, 0) .. (-0.383, -0.924, 0) ..
(0, -1, 0) .. (0.383, -0.924, 0) ..
(0.707, -0.707, 0) .. (0.924, -0.383, 0) .. cycle;

```

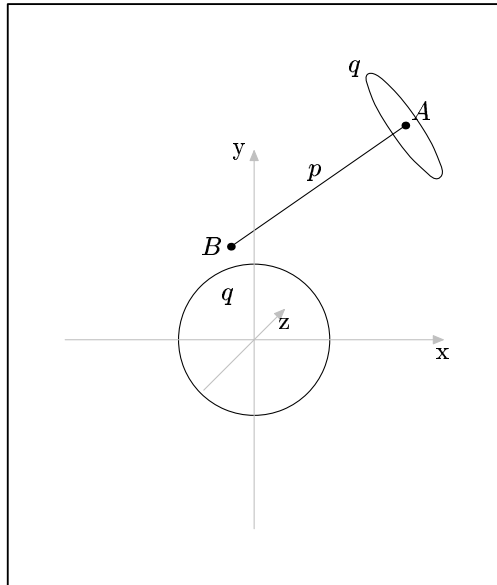

Figure 119.

## 26.11 Applying Transformations

**void apply\_transform** (void) [Virtual function]  
 Calls `Point::apply_transform()` on all of the `Points` on `points`. See Section 22.13 [Point Reference; Applying Transformations], page 134.

## 26.12 Drawing and Filling

```

void draw ([const Color& ddraw_color = [const virtual function]
             *Colors::default_color, [const string ddashed = "", [const string ppen
             = "", [Picture& picture = current_picture]]]])
void draw (Picture& picture, [const Color& [const Virtual function]
             ddraw_color = *Colors::default_color, [string ddashed = "", [string
             ppen = ""]])

```

Allocates a copy of the `Path` on the free store, puts a pointer to the copy on `picture.shapes`, sets its `fill_draw_value` to `DRAW`, and the values of its `draw_color`, `dashed`, and `pen` according to the arguments.

The second version is convenient for passing a `Picture` argument without having to specify all of the other arguments.

All of the arguments to `draw()` are optional, so it can be invoked as follows:

```
Point A;
Point B(2);
Point C(3, 3);
Point D(1, 2);
Point E(-1, 1);
Path p("..", true, &A, &B, &C, &D, &E, 0);
p.draw();
```

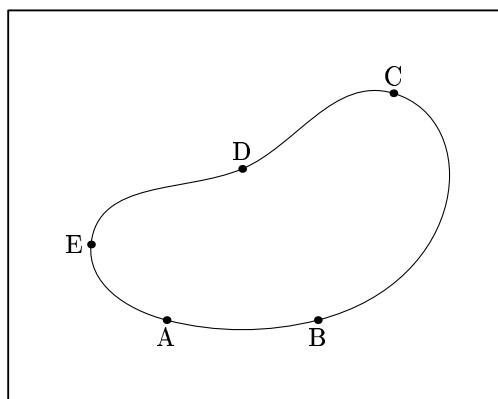

Figure 120.

The arguments:

*ddraw\_color*

Used to specify a color for the `Path`. *ddraw\_color* is a reference to a `Color`. Colors are described in Chapter 16 [Color Reference], page 87.

The most basic `Colors` are predefined in 3DLDF (in the namespace `Colors`), and users may create new `Colors` and specify their red-green-blue values.

The `Path` `p` could be drawn in red by calling `p.draw(Colors::red)`. This manual isn't intended to be printed in color, so there's no figure to demonstrate this. However, gray values can be printed on non-color printers.

```
using namespace Colors;
p.draw(gray, "", "pencircle scaled .25mm");
```

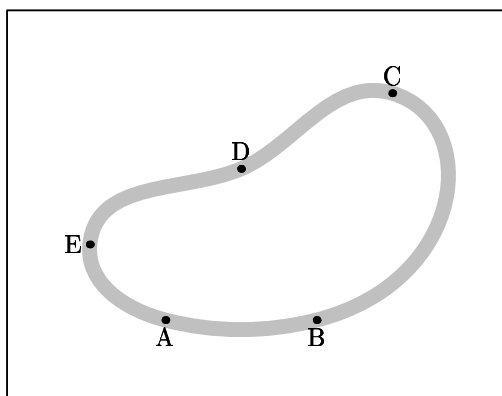

Figure 121.



*ddashed* A **string** representing a “dash pattern”, as defined in MetaPost<sup>5</sup>. Dash patterns have no meaning in 3DLDF, they are simply **strings** that are written unchanged to `out_stream`.

```
p.draw(black, "evenly");
```

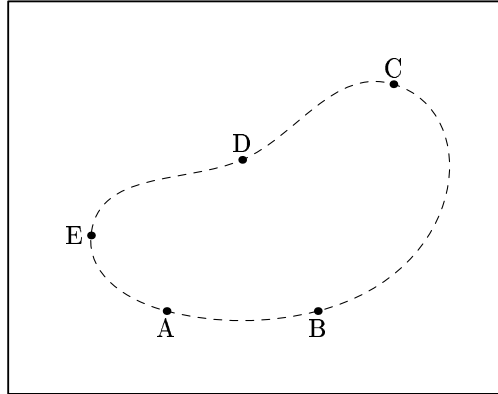

Figure 122.

*ppen* A **string** representing a “pen”, as defined in Metafont and MetaPost<sup>6</sup>. Pens have no meaning in 3DLDF, they are simply **strings** that are written unchanged to `out_stream`.

```
p.draw(black, "", "pensquare xscaled 3mm
        yscaled .25mm scaled .5mm");
```

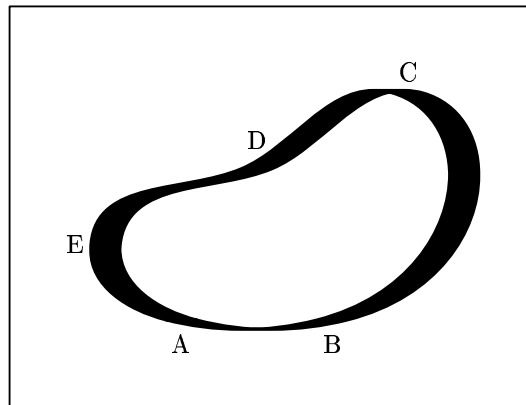

Figure 123.

*picture* Indicates the **Picture** on which the **Path** should be drawn.

The two versions of `draw()` differ in the position of the *picture* argument: In the first version, it’s the last argument, while in the second version, it’s the first argument. If a *picture* argument is used, it’s often more convenient to use the second version.

The following example puts **Path** `p` onto `temp_picture`. It also demonstrates how the labels are put onto `temp_picture`, and how

<sup>5</sup> Hobby, *A User’s Manual for MetaPost*, p. 32.

<sup>6</sup> Knuth, *The METAFONTbook*, Chapter 4, p. 21ff. Hobby, *A User’s Manual for MetaPost*, p. 32.

`temp_picture` is output. In the previous examples, the commands for making the labels and outputting `current_picture` were left out in order to reduce clutter. See Section 22.19 [Point Reference; Labelling], page 146, and Section 21.8.2 [Picture Reference; Outputting; Output Functions], page 114.

```
Picture temp_picture;
p.draw(temp_picture);
A.dotlabel("A", "bot", temp_picture);
B.dotlabel("B", "bot", temp_picture);
C.dotlabel("C", "top", temp_picture);
D.dotlabel("D", "top", temp_picture);
E.dotlabel("E", "lft", temp_picture);
temp_picture.output(Projections::PARALLEL_X_Y);
```

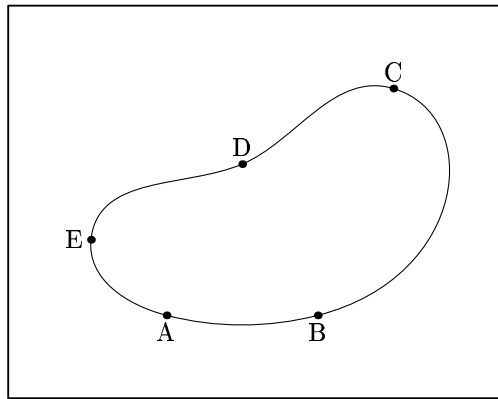

Figure 124.

```
void draw_help ([const Color& ddraw_color = *help_color, [const function]
                [string ddashed = help_dash_pattern, [string ppen = "", [Picture&
                picture = current_picture]]]])
void draw_help (Picture& picture, [const Color& ddraw_color [const function]
                = *help_color, [string ddashed = help_dash_pattern, [string ppen =
                ""]]])
```

These functions are for drawing help lines. They are like `draw()`, except that `draw_help()` returns immediately, if `do_help_lines` (a static data member in `Path`) is `false`. Also, the defaults for `ddraw_color` and `ddashed` differ from those for `draw()`.

```
void drawarrow ([const Color& ddraw_color = [const virtual function]
                *Colors::default_color, [string ddashed = "", [string ppen = "",
                [Picture& picture = current_picture]]]])
void drawarrow (Picture& picture, [const Color& [const virtual function]
                ddraw_color = *Colors::default_color, [string ddashed = "", [string
                ppen = ""]]])
```

Like `draw()`, except that the MetaPost command `drawarrow` is written to `out_stream` when `picture` is output. The second version is convenient for passing a `Picture` argument without having to specify all of the other arguments.

```
Point m;
```

```

Point n(2, 2);
m.dotlabel("$m$", "bot");
n.dotlabel("$n$");
m.drawarrow(n);

```

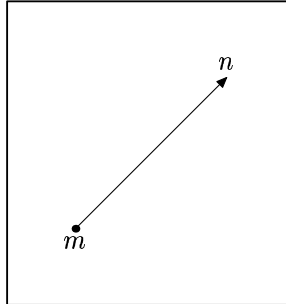

Figure 125.

```

void draw_axes ([real dist = 2.5, [string pos_x =          [Non-member function]
"bot", [string pos_y = "lft", [string pos_z = "bot", [const Color&
ddraw_color = *Colors::default_color, [const string ddashed = "",
[const string ppen = "", [const Point& shift_x = origin, [const Point&
shift_y = origin, [const Point& shift_z = origin, [Picture& picture =
current_picture]]]]]]]]]]))
void draw_axes (const Color& ddraw_color, [real dist      [Non-member function]
= 2.5, [string pos_x = "bot", [string pos_y = "lft", [string pos_z =
"bot", [const string ddashed = "", [const string ppen = "", [const
Point& shift_x = origin, [const Point& shift_y = origin, [const Point&
shift_z = origin, [Picture& picture = current_picture]]]]]]]]))

```

These functions draw lines centered on the origin, and ending in arrows in the directions of the positive x, y, and z-axes, and labels them with the appropriate letters. `draw_axes()` is used in many of the figures in this handbook. It can be helpful in determining whether a Focus has a good “up” direction. See Section 23.1 [Focus Reference; Data Members], page 150.

In the first version, all of the arguments are optional. In the second version, `ddraw_color` is required and has been moved to the front of the argument list. This version is often convenient, when a `Color` other than the default is desired.

The arguments:

*dist*            The length of the lines drawn. The default is 2.5. The value 0 can be used as a dummy argument, if the default for *dist* is desired, but other arguments must be specified.

*pos\_x*

*pos\_y*

*pos\_z*

The position arguments for the labelling commands for each of the axes. The defaults are “bot” for the x and z-axes, and “lft” for the y-axis. The usual strings for the position of labels can be used, namely: “top”, “bot”, “lft”, “rt”, “ulft”, “urt”, “llft”, “lrt”, and “”. If “” is used, that axis is not drawn. This can be useful for parallel projections

onto one of the major planes<sup>7</sup>. In addition, "d" can be used to indicate that the default should be used for that label. This can be useful if one needs a placeholder, but doesn't remember what the default is for that label.

```
draw_axes(0, "bot", "rt", "");
current_picture.output(Projections::PARALLEL_X_Y);
```

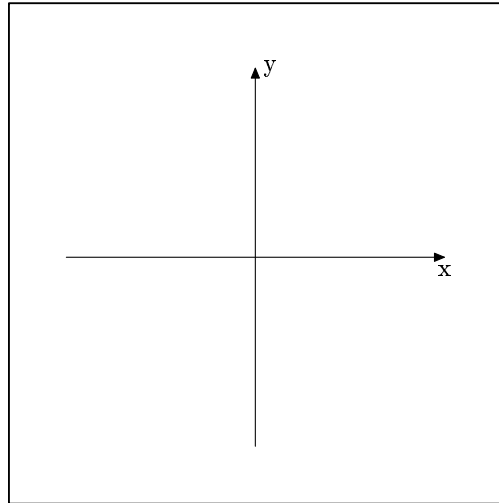

Figure 126.

In addition, the arguments *shift\_x*, *shift\_y*, and *shift\_z* can be used to adjust the positions of the labels further (see below).

*ddraw\_color*

*ddashed*

*ppen* Arguments for the `drawarrow()` command, described above, in this section.

*shift\_x*

*shift\_y*

*shift\_z*

Offsets for the labels. These arguments make it possible to adjust the positions of the labels. The defaults are `origin`, so no shifting takes place, if they are used. In Fig. 127, `draw_axes` is called without any arguments, so the defaults are used.

```
draw_axes();
```

---

<sup>7</sup> The usual interpretation of "" as a position argument to a labelling command would be to put it directly onto `*(Label.pt)`, which in this case would put it onto the arrowhead. Since this will probably never be desirable, I've decided to use "" to suppress drawing axes. Formerly, `draw_axes()` used three additional arguments for this purpose.

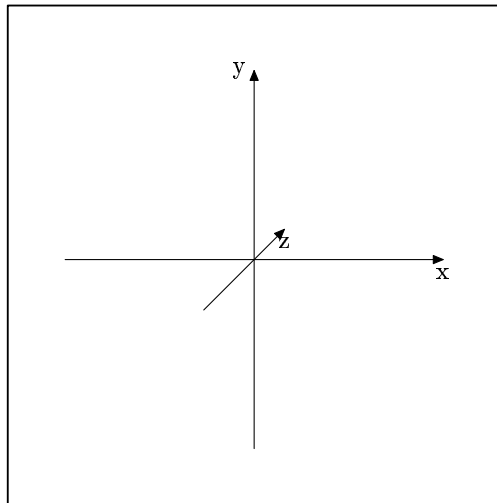

Figure 127.

In Fig. 128, the `Point P` is used to shift the labels. Please note that placeholders must be used for the first arguments.

```
Point P(.5, .5, .5);
draw_axes(0, "d", "d", "d", black, "", "", P, -P, P);
```

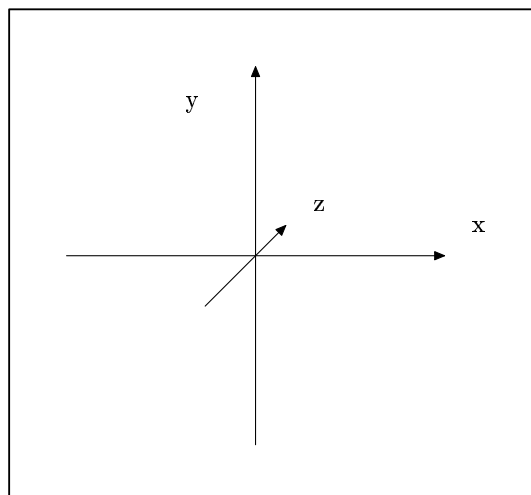

Figure 128.

Please note that the `Points` used for placing the labels are three-dimensional `Points`, whether the `shift_x`, `shift_y`, and/or `shift_z` arguments are used or not. It is not currently possible to adjust the positions of the labels on the two-dimensional projection itself. This would probably be more useful, but would require changing the way `Picture::output()` functions.

*picture*     The `Picture`, onto which the `Paths` and `Labels` are put.

```
void fill ([const Color& ffill_color = [const function]
          *Colors::default_color, [Picture& picture = current_picture]])
void fill (Picture& picture, [const Color& ffill_color = [Function]
          *Colors::default_color])
```

Allocates a copy of the Path on the free store, puts a pointer to it onto *picture.shapes*, sets its *fill\_draw\_value* to FILL, and its *fill\_color* to *\*ffill\_color*.

The second version is convenient for passing a *Picture* argument without having to specify all of the other arguments.

The arguments are similar to those of *draw()*, except that the *Color* argument is called *ffill\_color* instead of *ddraw\_color*.

```
p.fill(gray);
```

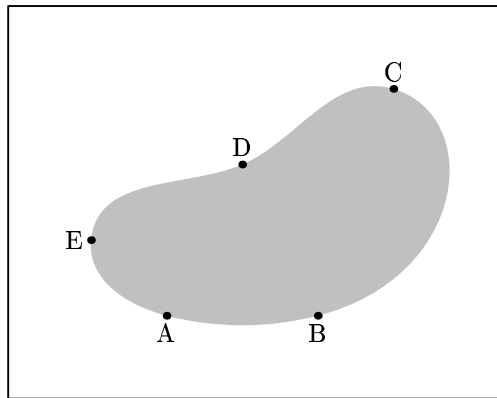

Figure 129.

```
void filldraw ([const Color& ddraw_color = [const function]
              *Colors::default_color, [const Color& ffill_color =
              *Colors::background_color, [string ddashed = "", [string ppen = "",
              [Picture& picture = current_picture]]]])
void filldraw (Picture& picture, [const Color& ddraw_color = [const function]
              *Colors::default_color, [const Color& ffill_color =
              *Colors::background_color, [string ddashed = "", [string ppen = ""]]])
```

Allocates a copy of the Path on the free store, puts a pointer to the copy onto *picture.shapes*, sets its *fill\_draw\_value* to FILLDRAW, its *draw\_color* and *fill\_color* to *\*ddraw\_color* and *\*ffill\_color*, respectively, its *dashed* to *ddashed*, and its *pen* to *ppen*.

The second version is convenient for passing a *Picture* argument without having to specify all of the other arguments.

The arguments are similar to those of *draw()* and *fill()*, except that both *ddraw\_color* and *fill\_color* are used.

3DLDF's *filldraw()* differs from Metafont's and MetaPost's *filldraw* commands: In Metafont and MetaPost, *filldrawing* is equivalent to filling a path and then drawing its border using the *pen*. Metafont does not have colors. While MetaPost does, its *filldraw* command does not foresee the use of different colors for drawing and filling.

```
p.filldraw(black, gray, "", "pencircle scaled 2mm");
```

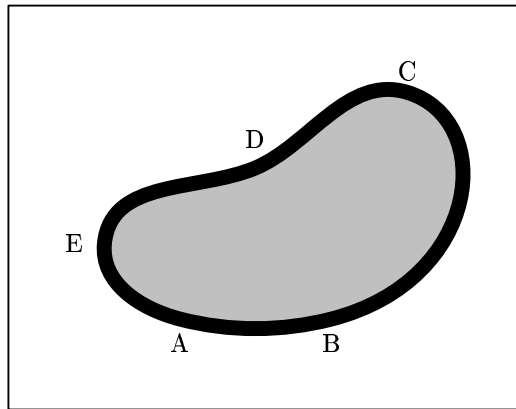

Figure 130.

It can often be useful to draw the outline of a `Path`, but to have it hide objects that lie behind it. This is why the default for `fill_color` is `*Colors::background_color`.

```
default_focus.set(3, 0, -10, 3, 10, 10, 10);
Point p[8];
p[0] = p[1] = p[2] = p[3] = p[4]
      = p[5] = p[6] = p[7].set(-1, -1, 5);
p[1] *= p[2] *= p[3] *= p[4] *= p[5]
      *= p[6] *= p[7].rotate(0, 0, 45);
p[2] *= p[3] *= p[4]
      *= p[5] *= p[6] *= p[7].rotate(0, 0, 45);
p[3] *= p[4] *= p[5] *= p[6]
      *= p[7].rotate(0, 0, 45);
p[4] *= p[5] *= p[6] *= p[7].rotate(0, 0, 45);
p[5] *= p[6] *= p[7].rotate(0, 0, 45);
p[6] *= p[7].rotate(0, 0, 45);
p[7].rotate(0, 0, 45);
Path r0("..", true, &p[0], &p[1], &p[2],
        &p[3], &p[4], &p[5], &p[6], &p[7], 0);
r0.filldraw(black, light_gray);
r0.scale(2, .5);
r0.shift(0, 0, -2.5);
r0.filldraw(black, gray);
r0.scale(.25, 3);
r0.shift(0, 0, -2.5);
r0.filldraw();
```





**void unfill** ([Picture& *picture* = *current\_picture*]) [Function]  
 Allocates a copy of the Path on the free store, puts a pointer to it on *picture.shapes* and sets its *fill\_draw\_value* to UNFILL

This function is useful for removing a portion of a filled region.

```
Point pt[4];
pt[0].set(-2, -2);
pt[1].set(2, -2);
pt[2].set(2, 2);
pt[3].set(-2, 2);
Path p("--", true, &pt[0], &pt[1], &pt[2], &pt[3], 0);
p.draw();
p.dotlabel();
p.filldraw(black, gray);
p.scale(.5, .5);
p.unfill();
```

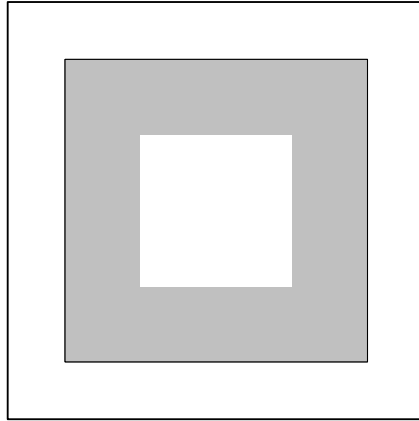

Figure 133.

**void unfilldraw** ([const Color& *ddraw\_color* = [Function]  
 \*Colors::background\_color, [string *ddashed* = "", [string *ppen* = "",  
 [Picture& *picture* = *current\_picture*]]]])

**void unfilldraw** (Picture& *picture*, [const Color& *ddraw\_color* = [Function]  
 \*Colors::background\_color, [string *ddashed* = "", [string *ppen* = ""]])

Allocates a copy of the Path on the free store, puts a pointer to it on *picture.shapes*, sets its *fill\_draw\_value* to UNFILLDRAW, and the values of its *draw\_color*, *dashed*, and *pen* according to the arguments. While the default for *ddraw\_color* is \*Colors::background\_color, any other Color can be used, so that *unfilldraw()* can unfill a Path and draw an outline around it.

The second version is convenient for passing a Picture argument without having to specify all of the other arguments.

This function is similar to *unfill()* (see Section 26.12 [Path Reference; Drawing and Filling], page 179), except that the outline of the Path will be “undrawn” using the pen specified with the *ppen* argument, or MetaPost’s *currentpen*, if no *ppen* argument is specified. In addition, the Path will be drawn using the Color specified

in the `ddraw_color` argument. Since the default is `*Colors::background_color`, the Path will be “undrawn” unless a different Color is specified.

```
Point pt[6];
pt[0].set(-2, -2);
pt[1].set(0, -3);
pt[2].set(2, -2);
pt[3].set(2, 2);
pt[4].set(0, 3);
pt[5].set(-2, 2);
Path p("--", true, &pt[0], &pt[1], &pt[2],
        &pt[3], &pt[4], &pt[5], 0);
p.fill(gray);
p.scale(.5, .5);
p.unfilldraw(black, "", "pensquare xscaled 3mm");
```

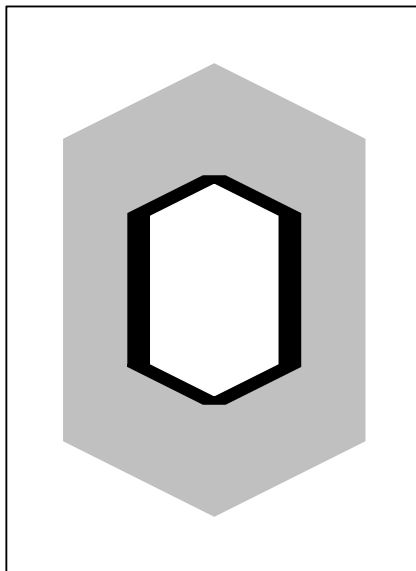

Figure 134.

## 26.13 Labelling

```
void label ([unsigned int i = 0, [string position_string = [const function]
    "top", [short text_short = 0, [bool dot = false, [Picture& picture =
    current_picture]]]])
```

```
void label (Picture& picture, [unsigned int i = 0, [string [const function]
    position_string = "top", [short text_short = 0, [bool dot = false]]])
```

Calls `Point::label()` on all of the Points on `points`. They are numbered consecutively starting with `i`. The other arguments are used for all of the Points, so it's not possible to specify different positions for the labels for different Points. `dot` will normally not be specified, unless a `picture` argument is used in the first version. `dotlabel()` calls `label()` with `dot = true`.

The second version is convenient for passing a `Picture` argument without having to specify all of the other arguments.

```
void dotlabel ([unsigned int i = 0, [string position_string = [const function]
               "top", [short text_short = 0, Picture& picture = current_picture]]])
void dotlabel (Picture& picture, [unsigned int i = 0, [string [const function]
               position_string = "top", [short text_short = 0]]])
Like label(), except that the Points are dotted.
```

## 26.14 Showing

```
void show ([string text = "", [char coords = 'w', [const bool [const function]
               do_persp = true, [const bool do_apply = true, [Focus* f = 0, [const
               unsigned short proj = Projections::PERSP, [const real factor = 1]]]]]])
```

Prints information about the `Path` to standard output (`stdout`). `text` is simply printed out, unless it's the empty string, in which case "Path:" is printed out. `coords` indicates which set of coordinates should be shown. Valid values are 'w' for the `world_coordinates`, 'p' for the `projective_coordinates`, 'u' for the `user_coordinates`, and 'v' for the `view_coordinates`, whereby the latter two are currently not in use (see Section 22.1 [Point Reference; Data Members], page 118). If `do_apply` is true, `apply_transform()` is called on each `Point`, updating its `world_coordinates` and resetting its `transform`. Otherwise, it's not. The arguments `do_persp`, `f`, `proj`, and `factor` are only relevant when showing `projective_coordinates`. If `do_persp` is true, the `Points` are projected using the values of `f`, `proj`, and `factor` (see Section 26.16 [Path Reference; Outputting], page 196). Otherwise, the values currently stored in `projective_coordinates` are shown. The `Points` and connectors are printed out alternately to standard output, followed by the word "cycle", if `cycle_switch = true`.<sup>8</sup>

```
    default_focus.set(0, 3, -10, 0, 3, 10, 10);
    Reg_Polygon r(origin, 5, 3, 45);
    r.fill(gray);
    Point p[10];
    for (int i = 0; i < 5; ++i)
        p[i] = r.get_point(i);
    p[5] = Point::intersection_point(p[4], p[0], p[2], p[1]).pt;
    p[6] = Point::intersection_point(p[0], p[1], p[2], p[3]).pt;
    p[7] = Point::intersection_point(p[1], p[2], p[4], p[3]).pt;
    p[8] = Point::intersection_point(p[2], p[3], p[0], p[4]).pt;
    p[9] = Point::intersection_point(p[3], p[4], p[0], p[1]).pt;
    Path q("--", true, &p[0], &p[5], &p[1], &p[6], &p[2], &p[7],
           &p[3], &p[8], &p[4], &p[9], 0);
    q.draw();
    q.show("q:");
    ─ q:
    fill_draw_value == 0
```

<sup>8</sup> The following example shows only one `Point` per line. In actual use, two `Points` are shown, but this causes overfull boxes in Texinfo.

```

(0, 1.06066, 1.06066)
-- (-2.30826, 2.24651, 2.24651)
-- (-1.42658, 0.327762, 0.327762)
-- (-3.73485, -0.858092, -0.858092)
-- (-0.881678, -0.858092, -0.858092)
-- (4.92996e-07, -2.77684, -2.77684)
-- (0.881678, -0.858092, -0.858092)
-- (3.73485, -0.858092, -0.858092)
-- (1.42658, 0.327762, 0.327762)
-- (2.30826, 2.24651, 2.24651) -- cycle;
q.show("q:", 'p');
└ q:
fill_draw_value == 0
Projective coordinates.
(0, -1.75337, 0.0958948)
-- (-1.88483, -0.615265, 0.183441)
-- (-1.38131, -2.58743, 0.031736)
-- (-4.08541, -4.22023, -0.0938636)
-- (-0.964435, -4.22023, -0.0938636)
-- (0, -7.99767, -0.384436)
-- (0.964436, -4.22023, -0.0938636)
-- (4.08541, -4.22023, -0.0938636)
-- (1.38131, -2.58743, 0.031736)
-- (1.88483, -0.615266, 0.183441) -- cycle;

```

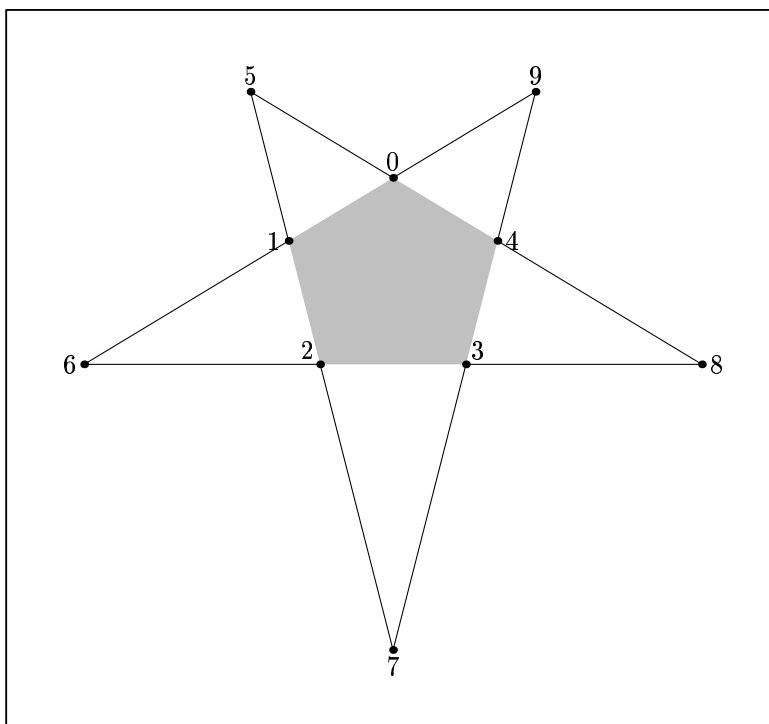

Figure 135.

**void show\_colors** ([bool = false]) [Function]  
Shows the values of `draw_color` and `fill_color`. These will normally be 0, unless the `Path` is on a `Picture`.

## 26.15 Querying

**bool is\_on\_free\_store** (void) [const function]  
Returns `true`, if the `Path` was dynamically allocated on the free store, otherwise `false`.

**bool is\_planar** ([const bool verbose = false, [string text = ""]] [const virtual function]  
Uses `get_normal()` to determine whether the `Path` is planar or not. Returns `true`, if it is, otherwise `false`. If `verbose` is `true`, `text` is written to standard output, or "Path:", if `text` is the empty string, followed by a message saying whether the `Path` is planar or not.

**bool is\_linear** ([const bool verbose = false, [string text = ""]] [const function]  
Returns `true`, if `line_switch` is `true`. Otherwise, `is_linear()` uses `get_normal()` to determine whether the `Path` is linear. If it is, `is_linear()` returns `true`, otherwise `false`.

**bool is\_cycle** (void) [Inline const function]  
Returns `true` if the `Path` is cyclical, i.e., `cycle_switch = true`, otherwise `false`. Only cyclical `Paths` are fillable.

**int size** (void) [Inline function]  
Returns the number of `Points` on `points`, i.e., `points.size()`.

**bool get\_line\_switch** (void) [Inline const function]  
Returns the value of `line_switch`. `line_switch` is only `true`, if the `Path` was created, directly or indirectly, using the constructor taking two `Point` arguments only. See Section 26.2 [Path Reference; Constructors and Setting Functions], page 166.

**real slope** ([char a = 'x', [char b = 'y']] [Function]  
Returns the slope of the `Path` in the plane indicated by the arguments, if `is_linear()` returns `true`. Otherwise, `slope()` issues an error message and returns `INVALID_REAL`.

**Path subpath** (size\_t start, size\_t end, [const bool cycle = false, [const string connector = ""]] [const function]  
Returns a new `Path` using `points[start]` through `points[end - 1]`. If `cycle` is `true`, then the new `Path` will be a cycle, whether `*this` is or not. One optional connector argument can be used. If it is, it will be the only connector. Otherwise, the appropriate connectors from `*this` are used.  
*start* must be  $< end$ . It is not possible to have  $start > end$ , even if `*this` is a cycle.

**const Point& get\_point** (const unsigned short a) [const function]  
Returns the `Point` `*points[a]`, if  $a < points.size()$  and the `Path` is non-empty, otherwise `INVALID_POINT`.

**const Point& get\_last\_point (void)** [const function]  
 Returns the **Point** pointed to by the last pointer on **points**. Equivalent to **get\_point(get\_size() - 1)**, but more convenient to type. Returns **INVALID\_POINT**, if the **Path** is empty.

**size\_t get\_size (void)** [const inline virtual function]  
 Returns **points.size()**.

**Line get\_line (void)** [const function]  
 Returns a **Line** corresponding to the **Path**, if the latter is linear. Otherwise, **INVALID\_LINE** is returned. See Chapter 24 [Line Reference], page 153.

**Point get\_normal (void)** [const virtual function]  
 Returns a **Point** representing a unit vector in the direction of the normal to the plane of the **Path**, or **INVALID\_POINT**, if the **Path** is non-planar.

```
Point P(1, 1, 1);
Rectangle r(P, 4, 4, 30, 30, 30);
Point N = r.get_normal();
```

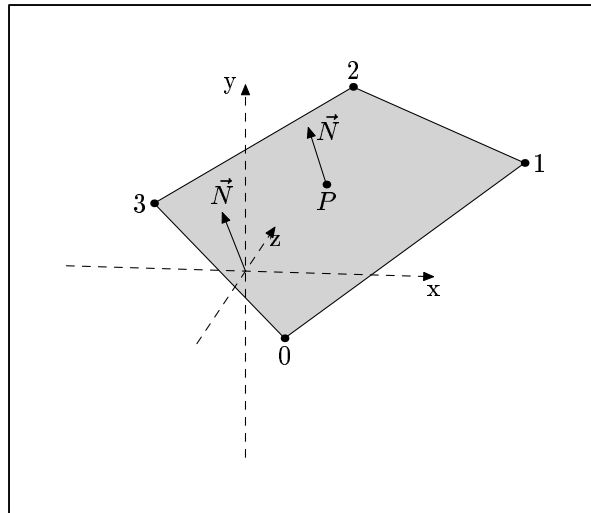

Figure 136.

In 3DLDF, plane figures generally have constructors taking a **|Point|** argument for the center, a variable number of **|real|** arguments for the dimensions, and three **|real|** arguments for the rotation about the major axes. The object is first created in the **x-z** plane, and the **Points** are generated to be traversed in the counter-clockwise direction, when seen from a **Point** with a positive **y**-coordinate. If no rotation is specified, the normal will point in the direction of the positive **y**-axis. If non-zero arguments are used for rotation, the normal will be rotated accordingly. This direction considered to be “outside”. However, according to Huw Jones, *Computer Graphics Through Key Mathematics*, p. 197, “outside” is considered to be the side of a plane, where the **Points** are meant to be traversed in the clockwise direction. I hope that no problems arise from this discrepancy!

**Plane** `get_plane` (void) [const virtual function]

Creates and returns a **Plane** *p* corresponding to the **Path**, if the latter is planar, otherwise `INVALID_PLANE`. If the **Path** is planar, *p.point* will be the **Point** pointed to by `this->points[0]`. See Chapter 25 [Plane Reference], page 156.

```
Point P(1, 1, 1);
Rectangle r(P, 4, 4, 45, 20, 15);
Plane q = r.get_plane();
q.show("q:");
├ q:
  normal: (0.0505914, 0.745607, -0.664463)
  point: (0.0178869, -0.727258, -1.01297)
  distance == -0.131735
```

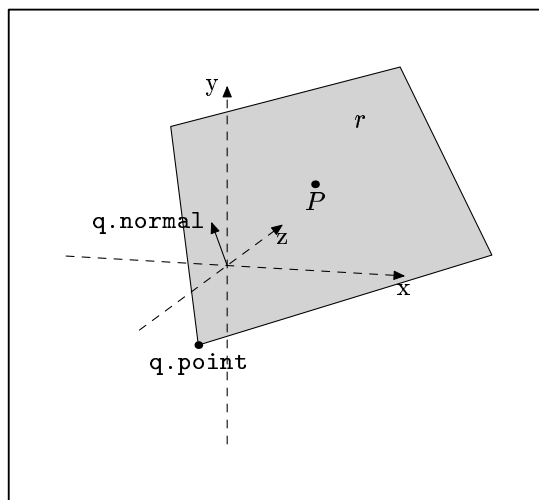

Figure 137.

**void** `set_cycle` ([const bool *c* = true]) [Function]  
 Sets `cycle_switch` to *c*.

**Path** `reverse` (bool *assign*) [Function]  
**Path** `reverse` (void) [const function]

These functions return a **Path** with the same **Points** and connectors as *\*this*, but in reversed order. `reverse()` can only be applied to non-cyclical **Paths**. If *\*this* is a cycle, `reverse()` issues an error message and returns *\*this* unreversed.

If the first version is called with `assign = true`, *\*this* itself is reversed. If *\*this* should remain unchanged, the `const` version without an argument should be called. If, on the other hand, the first version is called with `assign = false`, a warning message is issued, but the reversed **Path** is returned just the same, leaving *\*this* unchanged.

## 26.16 Outputting

**bool project** (const Focus& *f*, const unsigned short *proj*, real *factor*) [Function]

Calls `Point::project(f, proj, factor)` on the `Points` on the `Path`. If `Point::project()` fails (i.e., returns `false`), for any of the `Points`, this function returns `false`. Otherwise, it returns `true`.

**vector<Shape\*> extract** (const Focus& *f*, const unsigned short *proj*, real *factor*) [Function]

Checks that the `Points` on `points` can be projected using the values for *f*, *proj*, and *factor*. If they can, a `vector<Shape*>` containing only this is returned. Called in `Picture::output()`.

**bool set\_extremes** (void) [Virtual function]

Sets the appropriate elements in `projective_extremes` to the minimum and maximum values of the x, y, and z-coordinates of the `Points` on the `Path`. Used in `Picture::output()` for determining whether a `Path` can be output using the arguments passed to `Picture::output()`.

**const valarray<real> get\_extremes** (void) [Inline const virtual function]

Returns `projective_extremes`. Used in `Picture::output()`.

**real get\_minimum\_z** (void) [const virtual function]

**real get\_mean\_z** (void) [const virtual function]

**real get\_maximum\_z** (void) [const virtual function]

These functions return the minimum, mean, or maximum value, respectively, of the z-coordinates of the `Points` on the `Path`. Used in the surface hiding algorithm in `Picture::output()`.

**void suppress\_output** (void) [Virtual function]

Called in `Picture::output()`. Sets `do_output` to `false`, if the `Path` cannot be output using the arguments passed to `Picture::output()`.

**void unsuppress\_output** (void) [Virtual function]

Called in `Picture::output()`. Resets `do_output` to `true` after `output()` is called on the `Shapes` on `shapes` in a `Picture`, so that the `Path` can be output if `Picture::output()` is called again, with arguments that allow the `Path` to be output.

**void output** (void) [Virtual function]

Called in `Picture::output()`. Writes the MetaPost code to `out_stream` for drawing, filling, filldrawing, undrawing, unfilling, or unfilldrawing the `Path`, if the latter was projectable using the arguments passed to `Picture::output()`.



## 26.17 Intersections

`bool_point intersection_point (const Path& p, const bool trace)` [Function]

Finds the intersection point, if any, of two linear Paths. Let `bp` be the `bool_point` returned by this function. `bp.pt` will contain the intersection point, if it exists. If not, it will contain `INVALID_POINT`. If the intersection point exists and lies on both of the line segments represented by the Path and `p`, `bp.b` will be `true`, otherwise, `false`.

This function calls `Point::intersection_points()`, passing the first and last Points on `*this` and `p` as its arguments. If the `trace` argument is `false`, the version of `Point::intersection_points()` that finds the intersection point by means of a vector calculation is used. If it's `true`, the version that finds the intersection point of the traces of the lines on the major planes is used. See Section 22.17 [Point Reference; Intersections], page 142.

```
Point A(-1, -1, -1);
Point B(1, 1, 1);
Path p0(A, B);
Point C(-2, 1, 1);
Point D(1.75, 0.25, 0.25);
Path p1(C, D);
bool_point bp = p0.intersection_point(p1);
bp.pt.dotlabel("$i$");
bp.pt.show("bp.pt:");
└ bp.pt: (0.5, 0.5, 0.5)
```

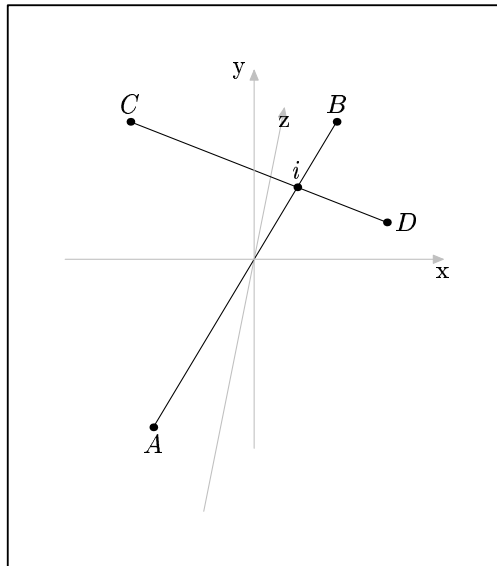

Figure 138.

## 27 Polygon Reference

Class `Polygon` is defined in `'polygons.web'`, and is derived from `Path`, using public derivation.

`Polygon` is mainly intended for use as a base class for more specialized kinds of polygons. Currently, the classes `Reg_Polygon` (regular polygon) and `Rectangle` are defined. See Chapter 28 [Regular Polygon Reference], page 204, and Chapter 29 [Rectangle Reference], page 210.

### 27.1 Data Members

`Point center` [Private variable]  
 The center of the `Polygon`, if it has one. However, a `Polygon` need not have a `center`. If it doesn't, `center` should be set to `INVALID_POINT`.

### 27.2 Operators

`Transform operator*= (const Transform& t)` [Virtual operator]  
 Multiplies a `Polygon` by the `Transform t`. Similar to `Path::operator*=(const Transform& t)`, except that `center` is transformed as well. See Section 26.4 [Path Reference; Operators], page 170.

### 27.3 Querying

`const Point& get_center (void)` [Virtual function]  
`Point get_center (void)` [const function]  
 These functions return `center`. If the `Polygon` doesn't contain any `Points`, a warning is issued, and `INVALID_POINT` is returned.

## 27.4 Affine Transformations

|                                                                                                             |                    |
|-------------------------------------------------------------------------------------------------------------|--------------------|
| Transform <b>rotate</b> (const real x, [const real y = 0, [const real z = 0]])                              | [Virtual function] |
| Transform <b>rotate</b> (const Point& p0, const Point& p1, [const real angle = 180])                        | [Virtual function] |
| Transform <b>rotate</b> (const Path& p, [const real angle = 180])                                           | [Virtual function] |
| Transform <b>scale</b> (real x, [real y = 1, [real z = 1]])                                                 | [Virtual function] |
| Transform <b>shear</b> (real xy, [real xz = 0, [real yx = 0, [real yz = 0, [real zx = 0, [real zy = 0]]]]]) | [Virtual function] |
| Transform <b>shift</b> (real x, [real y = 0, [real z = 0]])                                                 | [Virtual function] |
| Transform <b>shift</b> (const Point& p)                                                                     | [Virtual function] |
| void <b>shift_times</b> (real x, [real y = 1, [real z = 1]])                                                | [Virtual function] |
| void <b>shift_times</b> (const Point& p)                                                                    | [Virtual function] |

The affine transformation functions for `Polygon` differ from the `Path` versions only in that `center` is transformed as well. See Section 26.9 [Path Reference; Affine Transformations], page 173.

Please note, that the classes currently derived from `Polygon`, namely `Reg_Polygon` and `Rectangle`, currently inherit these functions from `Polygon`. The problem with this is, that they have data members, which are not recalculated when a `Reg_Polygon` or `Rectangle` is transformed. I plan to do something about this soon! It will also be necessary to add the function `Reg_Polygon::is_reg_polygonal()`, in order to test whether operations on a `Reg_Polygon` have caused it to become irregular and/or non-polygonal. Similarly, the function `Rectangle::is_rectangular()` must be added, to test whether operations on a `Rectangle` has caused it to become non-rectangular. See Section 28.1 [Regular Polygon Reference; Data Members], page 204, and Section 29.1 [Rectangle Reference; Data Members], page 210.

## 27.5 Intersections

|                                                                               |                  |
|-------------------------------------------------------------------------------|------------------|
| bool_point_pair <b>intersection_points</b> (const Point& p0, const Point& p1) | [const function] |
| bool_point_pair <b>intersection_points</b> (const Path& p)                    | [const function] |

These functions find the intersections of the `Polygon` and a line. In the first version, the `Point` arguments are the end points of the line. The argument to the second version must be a linear `Path`.

A line and a regular polygon or rectangle<sup>1</sup> can intersect at two points at most. Let `b` be a `bool_point_pair` returned by `intersection_points()`. If no intersection points are found, `b.first.pt` and `b.second.pt` will be `INVALID_POINT`, and `b.first.b` and `b.second.b` will be `false`. If a single intersection point is found, the corresponding `Point` will be stored in `b.first.pt`. If the `Point` is on the line segment  $\overrightarrow{p_0p_1}$ , `b.first.b` will be `true`, otherwise `false`. If a second intersection point is found, it will be stored in `b.second.pt`, and `b.second.b` is set analogously to `b.first.b`.

<sup>1</sup> `Reg_Polygon` and `Rectangle` are currently the only classes derived from `Polygon`.

When the `Point` arguments and the `Reg_Polygon` are coplanar, as in Fig. 139, two intersection points are possible. In this case, only intersection points of the line with an edge of the `Reg_Polygon` are returned in the `bool_point_pair`.

```
Point A(1, 1, 1);
Reg_Polygon r(origin, 5, 3);
Transform t;
t.rotate(15, 12, 11);
t.shift(A);
Point P(-2, 0, -1);
Point Q(2, 0, 1);
P *= Q *= r *= t;
bool_point_pair bpp = r.intersection_points(P, Q);
bpp.first.pt.dotlabel("$f$", "rt");
bpp.second.pt.dotlabel("$s$");
```

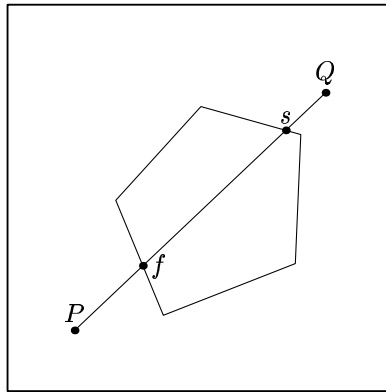

Figure 139.

In Fig. 140, the lines  $\overrightarrow{BC}$  and  $\overrightarrow{PQ}$  are not coplanar with the `Reg_Polygon`  $r$ . In each case, only one intersection point is possible, and it can be either an intersection with an edge of the `Reg_Polygon`, or lie within its perimeter.

```
Point B(r.get_point(3).mediate(r.get_point(4)));
Point C(B);
B.shift(0, 2, .5);
C.shift(0, -2, -.5);
Point P(-1, -2, -1);
Point Q(0, 2, 1);
B *= C *= P *= Q *= r *= t;
bool_point_pair bpp = r.intersection_points(B, C);
bpp.first.pt.dotlabel("$i_0$", "rt");
bpp = r.intersection_points(P, Q);
bpp.first.pt.dotlabel("$i_1$", "rt");
```

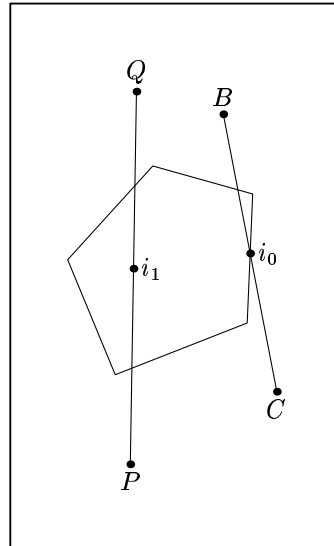

Figure 140.

In Fig. 141, the intersection point of  $r$  with the line  $\overrightarrow{PQ}$  does not lie on the line segment  $PQ$ .

```

bpp = r.intersection_points(P, Q);
bpp.first.pt.dotlabel("$i$", "rt");
cout << "bpp.first.b == " << bpp.first.b << endl << flush;
+ bpp.first.b == 0

```

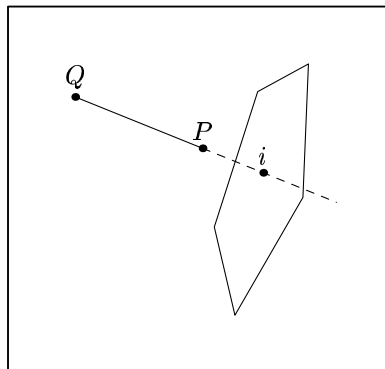

Figure 141.

**vector<Point> intersection\_points** (const Polygon& r) [const function]

Finds the intersection points of two Polygons. Let  $v$  be the **vector<Point>** returned by **intersection\_points()**. If the Polygons are coplanar,  $v$  will contain the intersection points of the edges of the Polygons, as in Fig. 142.

```

Rectangle r(origin, 4, 4);
Reg_Polygon rp(origin, 5, 5, 0, 36);
rp.shift(0, 0, .25);
vector <Point> v = r.intersection_points(rp);

```

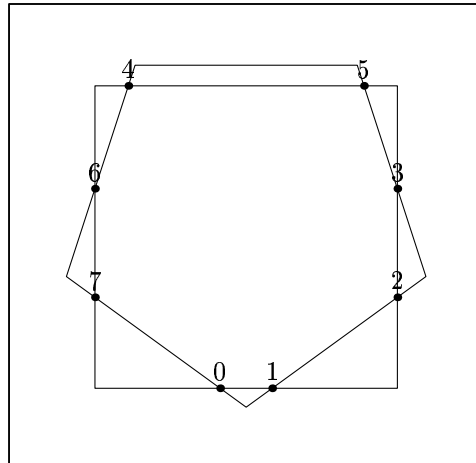

Figure 142.

If the `Polygons` lie in parallel planes, there can be no intersection points. If they lie in non-parallel, non-coplanar planes, `intersection_points()` first finds the intersection line of the two planes. Then it finds the intersection points of this line with the two `Polygons`, if they exist. There can no more than four intersection points, in this case. `v[0]` and `v[1]` will be the intersection points of the line with `*this`, while `v[2]` and `v[3]` will be the intersection points of the line with `r`. If one or more of the intersection points doesn't exist, the corresponding member of `v` will contain `INVALID_POINT` as a placeholder.

```
Point A(1, 1, 1);
Rectangle r(A, 4, 4);
Reg_Polygon p(A, 5, 5);
p.rotate(90, 30);
p.shift(2, 0, 3);
vector <Point> v = r.intersection_points(p);
```

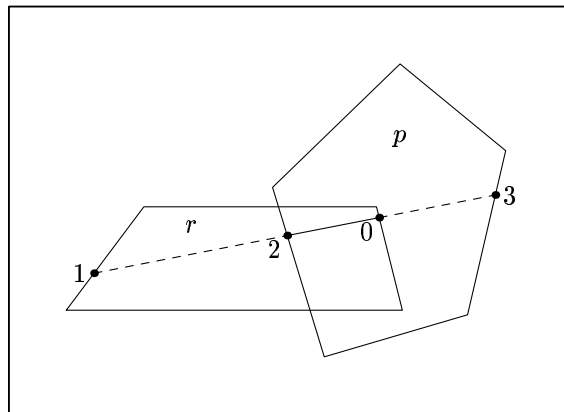

Figure 143.

In Fig. 144, the `Rectangle` `r` and the `Reg_Polygon` `p` don't overlap at all, nor does the intersection line of the two planes intersect with `p`. However, it does intersect with `p` at the labelled `Points`.

```
Point A(1, 1, 1);
Rectangle r(A, 4, 4);
Reg_Polygon p(A, 5, 5);
```

```
p.rotate(90, 30);  
p.shift(4, 3, 3);  
vector<Point> v = r.intersection_points(p);  
int i = 0;  
for (vector<Point>::iterator iter = v.begin();  
     iter != v.end(); ++iter)  
    iter->dotlabel(i++, "bot");
```

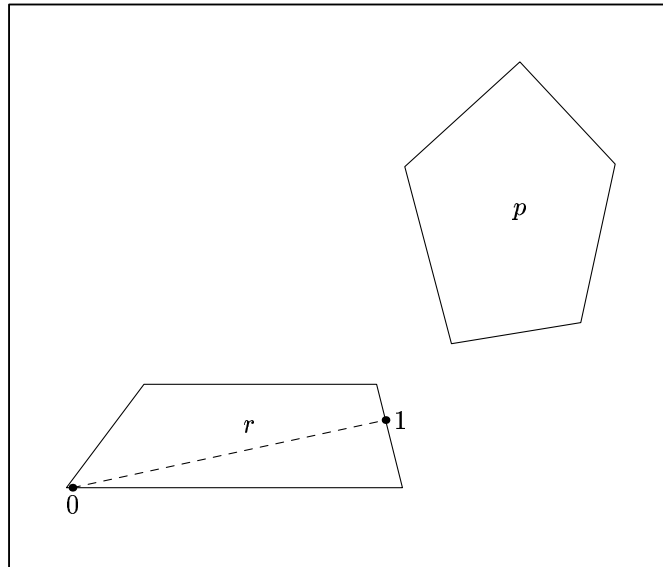

Figure 144.

## 28 Regular Polygon Reference

Class `Reg_Polygon` is defined in ‘`polygons.web`’, and is derived from `Polygon`, using public derivation.

As noted above in Section 27.4 [Polygon Reference; Affine Transformations], page 199, class `Reg_Polygon`, like class `Rectangle`, currently inherits its transformation functions and `operator*=(const Transform&)` from `Polygon`. Consequently, the data members of a `Reg_Polygon`, except for `center`, are not recalculated when it’s transformed. I plan to change this soon! It will also be necessary to add the function `Reg_Polygon::is_reg_polygonal()`, in order to test whether a `Reg_Polygon` is still regular and polygonal.

### 28.1 Data Members

**real `internal_angle`** [Private variable]

The angle at the center of the `Reg_Polygon` of the triangle formed by the center and two adjacent corners. If  $n$  is the number of sides of a `Reg_Polygon`, `internal_angle` will be  $360.0/n$ , so `internal_angle` will be 120 for a regular triangle, 90 for a square, 72 for a pentagon, etc.

**real `radius`** [Private variable]

The radius of the surrounding circle for a `Reg_Polygon` (*Umkreis*).

**unsigned short `sides`** [Private variable]

The number of sides of a `Reg_Polygon`.

**bool `on_free_store`** [Private variable]

`true`, if the `Reg_Polygon` was dynamically allocated on the free store, otherwise `false`. Dynamic allocation of `Reg_Polygons` should only be performed by `create_new<Reg_Polygon>()`, which sets `on_free_store` to `true`.

### 28.2 Constructors and Setting Functions

**void `Reg_Polygon` (void)** [Default constructor]

Creates an empty `Reg_Polygon`.

**void `Reg_Polygon` (const Point& *ccenter*, const unsigned short *ssides*, const real *ddiameter*, [const real *angle\_x* = 0, [const real *angle\_y* = 0, [const real *angle\_z* = 0]]])** [Constructor]

Creates a `Reg_Polygon` in the x-z plane, centered at the origin, with the number of sides specified by *ssides* and with `radius = ddiameter/2`.

The `Reg_Polygon` is rotated about the x, y, and z-axes in that order by the angles given by *angle\_x*, *angle\_y*, and *angle\_z*, respectively, if any one of them is non-zero. Finally, the `Reg_Polygon` is shifted such that its center is located at *ccenter*.

```
Reg_Polygon r(origin, 3, 2.75, 10, 15, 12.5);
r.draw();
```



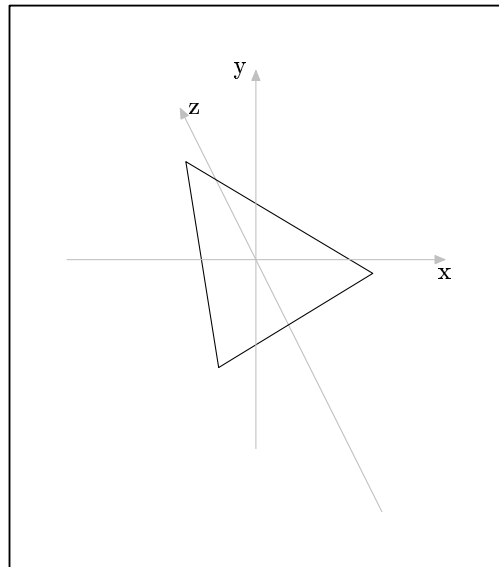

Figure 145.

```
void set (const Point& ccenter, const unsigned short ssides,    [Setting function]
         const real ddiameter, [const real angle_x = 0, [const real angle_y = 0,
         [const real angle_z = 0]]])
```

Corresponds to the constructor above.

A `Reg_Polygon` can theoretically have any number of sides, however I haven't tested it for unreasonably large values. The following example demonstrates that `set()` can be used to change a `Reg_Polygon`.

```
Reg_Polygon r;
real j = .5;
for (int i = 3; i <= 16; ++i)
{
    r.set(origin, i, j);
    r.draw();
    j += .5;
}
```

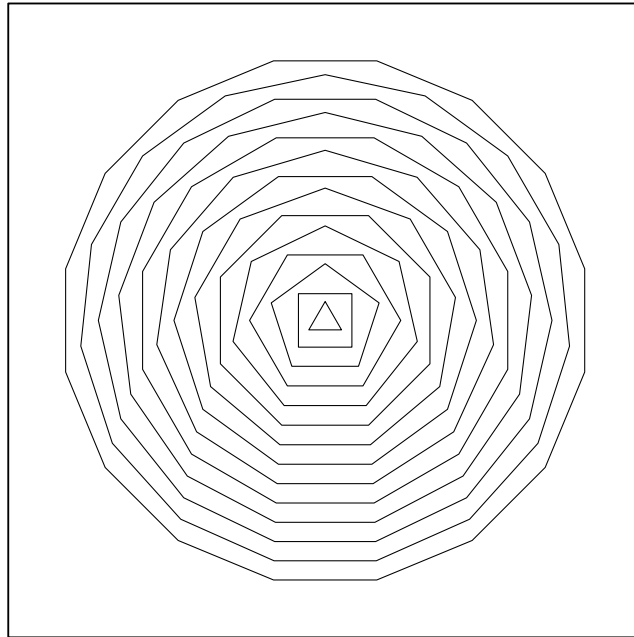

Figure 146.

```
Reg_Polygon* create_new<Reg_Polygon> (const [Template specializations]
    Reg_Polygon* r)
```

```
Reg_Polygon* create_new<Reg_Polygon> (const Reg_Polygon& r)
```

Pseudo-constructors for dynamic allocation of `Reg_Polygons`. They create a `Reg_Polygon` on the free store and allocate memory for it using `new(Reg_Polygon)`. They return a pointer to the new `Reg_Polygon`. If `r` is a non-zero pointer or a reference, the new `Reg_Polygon` will be a copy of `r`. If the new object is not meant to be a copy of an existing one, '0' must be passed to `create_new<Reg_Polygon>()` as its argument. See Chapter 14 [Dynamic Allocation of Shapes], page 83, for more information.

### 28.3 Operators

```
const Reg_Polygon& operator= (const Reg_Polygon& p) [Operator]
    Makes the Reg_Polygon a copy of p.
```

### 28.4 Querying

```
real get_radius (void) [const inline function]
    Returns radius.
```

### 28.5 Circles

```
Circle in_circle (void) [const function]
```

Returns the enclosed `Circle` of the `Reg_Polygon`.

```
Point P(0, -1, 1);
Reg_Polygon h(P, 6, 4, 15, 12, 11.5);
h.filldraw(black, gray);
```

```
Circle c = h.in_circle();
c.unfilldraw(black);
```

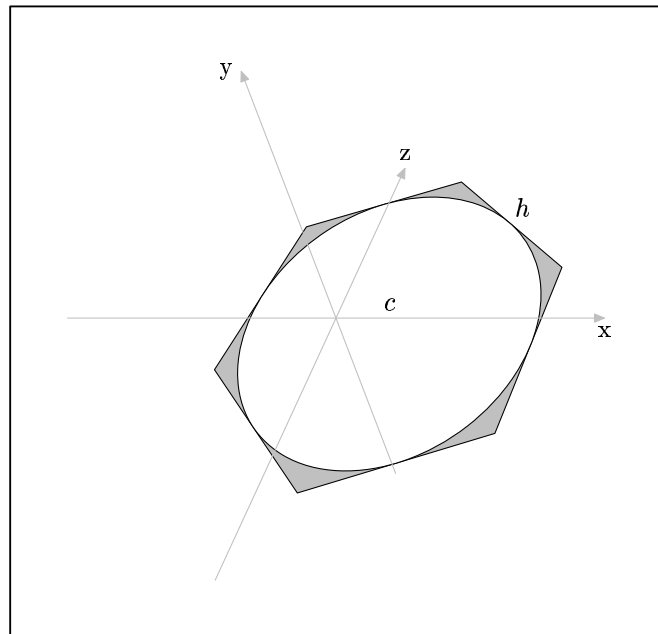

Figure 147.

```
Circle draw_in_circle ([const Color& ddraw_color = [const function]
    *Colors::default_color, [const string ddashed = "", [const string]
    ppen = "", [Picture& picture = current_picture]])
Circle draw_in_circle ([Picture& picture = current_picture, [const function]
    [const Color& ddraw_color = *Colors::default_color, [const string
    ddashed = "", [const string] ppen = ""]]])
Draws and returns the enclosed Circle of the Reg_Polygon.
```

```
Point P(0, 1, 1);
Reg_Polygon h(P, 7, 4, 80, 2, 5);
h.draw(black, "evenly");
h.draw_in_circle();
```

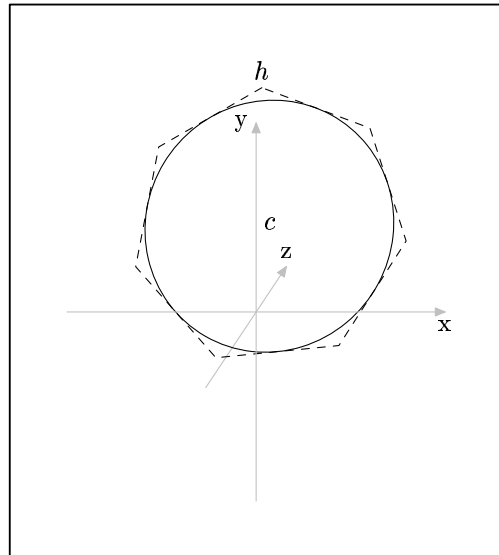

Figure 148.

**Circle out\_circle** (void)

[const function]

Returns the surrounding Circle of the Reg\_Polygon.

```
Point P(0, -1, 1);
Reg_Polygon h(P, 6, 4, 15, 12, 11.5);
Circle c = h.out_circle();
c.filldraw(black, gray);
h.unfilldraw(black);
```

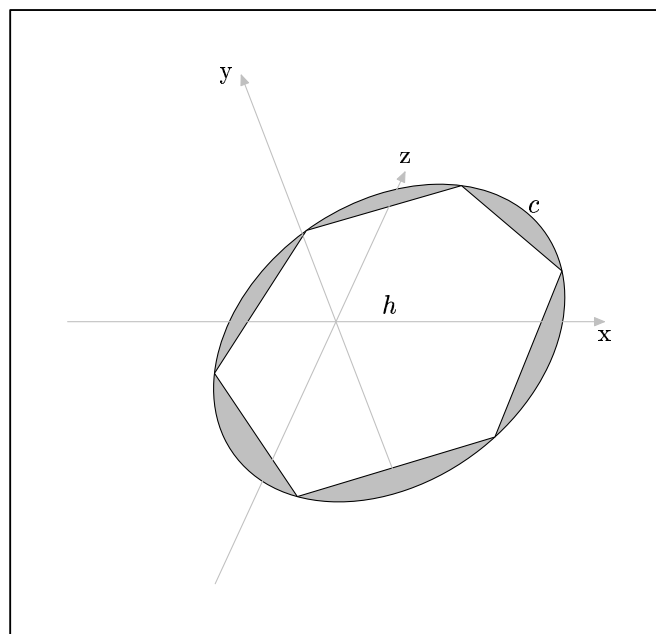

Figure 149.

```
Circle draw_out_circle ([const Color& ddraw_color =          [const function]
                        *Colors::default_color, [const string ddashed = "", [const string]
                        ppen = "", [Picture& picture = current_picture]])
```

```
Circle draw_out_circle ([Picture& picture =          [const function]
                        current_picture, [const Color& ddraw_color = *Colors::default_color,
                        [const string ddashed = "", [const string] ppen = ""]])
```

Draws and returns the surrounding Circle of the Reg\_Polygon.

```
Point P(0, 1, 1);
Reg_Polygon h(P, 7, 4, 80, 2, 5);
h.draw(black, "evenly");
h.draw_out_circle();
```

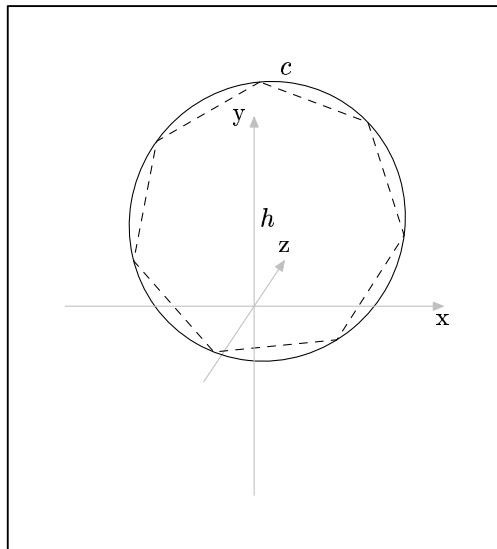

Figure 150.

## 29 Rectangle Reference

Class `Rectangle` is defined in `'rectangs.web'`, and is derived from `Polygon`, using public derivation.

As noted above in Section 27.4 [Polygon Reference; Affine Transformations], page 199, class `Rectangle`, like class `Reg_Polygon`, currently inherits its transformation functions and `operator*=(const Transform&)` from `Polygon`. Consequently, the data members of a `Rectangle`, except for `center`, are not recalculated when it's transformed. I plan to change this soon! It will also be necessary to add the function `Rectangle::is_rectangular()`, in order to test whether a `Rectangle` is still rectangular.

### 29.1 Data Members

`real axis_h` [Private variables]  
`real axis_v`

The lengths of the horizontal and vertical axes, respectively, of the `Rectangle`. Actually, they are merely the horizontal and vertical axes by convention, since there are no restrictions on the orientation of an `Rectangle`.

Please note that `axis_h` and `axis_v` are currently not recalculated, when a `Rectangle` is transformed. I plan to do something about this soon.

`bool on_free_store` [Private variable]  
`true`, if the `Rectangle` was dynamically allocated on the free store, otherwise `false`. Dynamic allocation of `Rectangles` should only be performed by `create_new<Rectangle>()`, which sets `on_free_store` to `true`.

### 29.2 Constructors and Setting Functions

`void Rectangle (void)` [Default constructor]  
 Creates an empty `Rectangle`.

`void Rectangle (const Point& ccenter, const real aaxis_h, [Constructor]  
                   const real aaxis_v, [const real angle_x = 0, [const real angle_y = 0,  
                   [const real angle_z = 0]]])`

Creates a `Rectangle` in the  $x$ - $z$  plane, centered at the origin, with width  $\equiv$  `aaxis_h` (in the  $\pm x$  direction), and height  $\equiv$  `aaxis_v` (in the  $\pm z$  direction). If one or more of the arguments `angle_x`, `angle_y`, or `angle_z` are used, it is rotated by those amounts around the appropriate axes. Finally, the `Rectangle` is shifted such that its center lies at `ccenter`.

```
Point C(-1, -1, 1);
Rectangle r(C, 3, 4, 30, 30, 30);
```

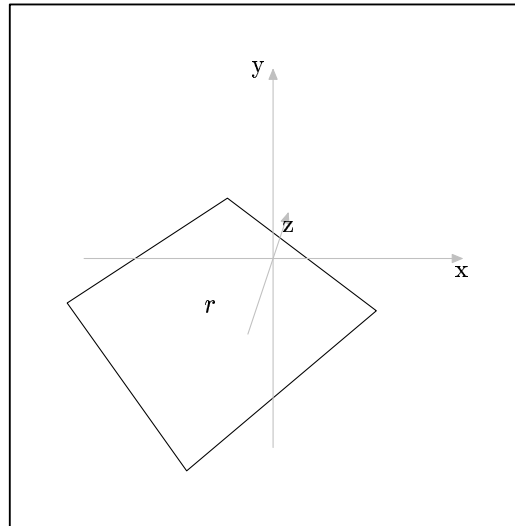

Figure 151.

```
void set (const Point& ccenter, const real axis_h, const [Setting function]
         real axis_v, [const real angle_x = 0, [const real angle_y = 0, [const
         real angle_z = 0]]])
```

Corresponds to the constructor described above.

```
void Rectangle (const Point& p0, const Point& p1, const Point& [Constructor]
                p2, const Point& p3)
```

Creates **Rectangle** using four **Point** arguments. The order of the arguments must correspond with a path around the **Rectangle**.

This function does not currently check that the arguments yield a valid **Rectangle**, therefore all code using it must ensure that they do.

```
void set (const Point& pt0, const Point& pt1, const Point& [Setting function]
         pt2, const Point& pt3)
```

Corresponds to the constructor above.

```
Rectangle* create_new<Rectangle> (const [Template specializations]
                                   Rectangle* r)
```

```
Rectangle* create_new<Rectangle> (const Rectangle& r)
```

Pseudo-constructors for dynamic allocation of **Rectangles**. They create a **Rectangle** on the free store and allocate memory for it using `new(Rectangle)`. They return a pointer to the new **Rectangle**.

If `r` is a non-zero pointer or a reference, the new **Rectangle** will be a copy of `r`. If the new object is not meant to be a copy of an existing one, '0' must be passed to `create_new<Rectangle>()` as its argument. See Chapter 14 [Dynamic Allocation of Shapes], page 83, for more information.

### 29.3 Operators

```
const Rectangle& operator= (const Rectangle& r) [Assignment Operator]
    Makes the Rectangle a copy of r.
```

## 29.4 Returning Points

**Point** `corner` (unsigned short *c*) [Function]  
Returns the corner **Point** indicated by the argument *c*, which must be between 0 and 3.

**Point** `mid_point` (unsigned short *m*) [const function]  
Returns the mid-point of one of the sides. The argument *c* must be between 0 and 3.

## 29.5 Querying

**real** `get_axis_h` (void) [const functions]  
**real** `get_axis_v` (void)  
These functions return `axis_h` and `axis_v`, respectively.

Please note, that `axis_h` and `axis_v` are currently not recalculated, when a **Rectangle** is transformed. I plan to do something about this soon.

**bool** `is_rectangular` (void) [const function]  
Returns **true**, if the **Rectangle** is rectangular, otherwise **false**. Transformations, such as shearing, can cause **Rectangles** to become non-rectangular.

## 29.6 Ellipses

**Ellipse** `out_ellipse` (void) [const function]  
Returns the smallest **Ellipse** that surrounds the **Rectangle**.

```
Point P(-1, -1, 3);
Rectangle r(P, 3, 4, 60, 30, 15);
Ellipse e = r.out_ellipse();
e.filldraw(black, gray);
r.unfilldraw(black);
```



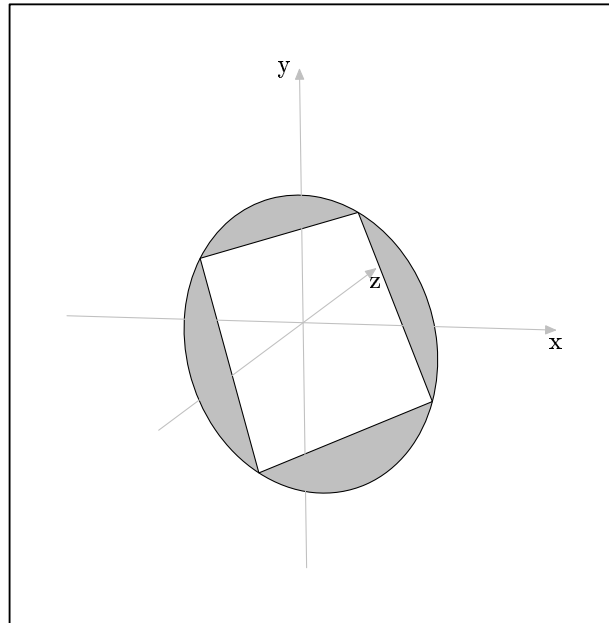

Figure 152.

Ellipse `in_ellipse` (void)

[const function]

Returns the Ellipse enclosed by the Rectangle.

```
Point P(-1, -1, 3);
Rectangle r(P, 3, 4, 60, 30, 15);
Ellipse e = r.in_ellipse();
r.filldraw(black, gray);
e.unfilldraw(black);
```

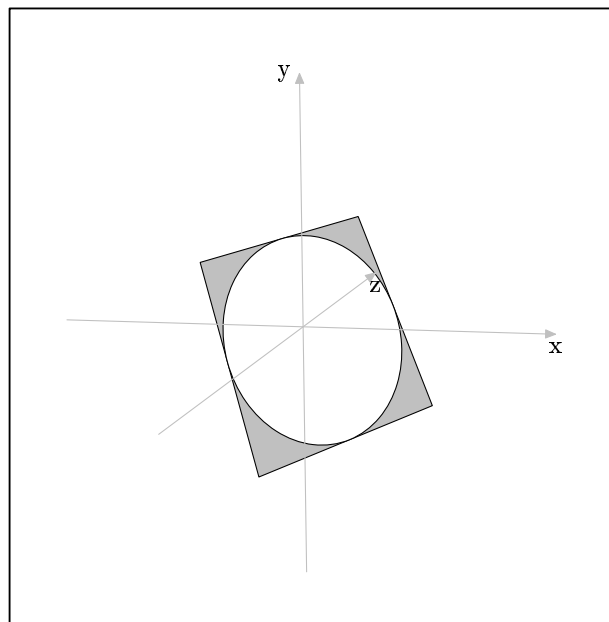

Figure 153.

Ellipse **draw\_out\_ellipse** ([const Color& ddraw\_color = [const function]  
\*Colors::default\_color, [string ddashed = "", [string ppen = "",  
[Picture& picture = current\_picture]]])

Draws the smallest **Ellipse** that surrounds the **Rectangle**. The arguments are like those of **Path::draw()** (see Section 26.12 [Path Reference; Drawing and Filling], page 179). The return value is the surrounding **Ellipse**.

Ellipse **draw\_in\_ellipse** ([const Color& ddraw\_color = [const function]  
\*Colors::default\_color, [string ddashed = "", [string ppen = "",  
[Picture& picture = current\_picture]]])

Draws the **Ellipse** enclosed by the **Rectangle**. The arguments are like those of **Path::draw()** (see Section 26.12 [Path Reference; Drawing and Filling], page 179). The return value is the enclosed **Ellipse**.

## 30 Regular Closed Plane Curve Reference

Class `Reg_C1_Plane_Curve` is defined in ‘`curves.web`’. It is derived from `Path` using `public` derivation.

`Reg_C1_Plane_Curve` is not called “`Regular_Closed_Plane_Curve`” because the longer name causes too many “Overfull boxes”<sup>1</sup> in the CWEAVE output of the program code. See Section 1.3 [CWEB Documentation], page 5.

`Reg_C1_Plane_Curve` is meant to be used as a base class; no objects should be declared of type `Reg_C1_Plane_Curve`. Currently, class `Ellipses` is derived from `Reg_C1_Plane_Curve` and class `Circle` is derived from `Ellipses`.

At present, I have no fixed definition of what constitutes “regularity” as far as `Reg_C1_Plane_Curves` are concerned. Ellipses and circles are “regular” in the sense that they have axes of symmetry. There must be an equation for a `Reg_C1_Plane_Curve`, such as  $x^2 + y^2 = r^2$  for a circle. A derived class should have a `solve()` function that uses this equation. `Reg_C1_Plane_Curve::intersection_points()` in turn uses `solve()` to find the intersection points of a line with the `Reg_C1_Plane_Curve`. This way, the derived classes don’t need their own functions for finding their intersections with a line. However, such functions can be added, if desired.

It is assumed that classes derived from `Reg_C1_Plane_Curve` are fillable, which implies that they must be closed `Paths`. `Reg_C1_Plane_Curves` inherit their drawing and filling functions from `Path`.

The constructors and setting functions of classes derived from `Reg_C1_Plane_Curve` must ensure that the resulting geometric figures are planar, convex, and that the number of `Points` they contain is a multiple of 4. The latter assumption is of importance in `intersection_points()`, `segment()`, `half()`, and `quarter()`. See Section 30.3 [Regular Closed Plane Curve Reference; Intersections], page 216, and Section 30.4 [Regular Closed Plane Curve Reference; Segments], page 218.

### 30.1 Data Members

`Point center` [Protected variable]

The center of the `Reg_C1_Plane_Curve`, if it has one.

`unsigned short number_of_points` [Protected variable]

The number of `Points` on `points` in a `Reg_C1_Plane_Curve`.

### 30.2 Querying

`bool is_quadratic (void)` [const inline virtual functions]

`bool is_cubic (void)`

`bool is_quartic (void)`

These functions all return `false`. They are intended to be overloaded by member functions of derived classes.

---

<sup>1</sup> If you don’t know what “overfull boxes” are, don’t worry about it. It has to do with T<sub>E</sub>X’s line and page breaking algorithms. If you want to know more, see Knuth, Donald E., *The T<sub>E</sub>Xbook*.

`real_triple get_coefficients (real Slope, real v_intercept)` [const inline virtual function]

Returns a `real_triple` with all three values  $\equiv$  `INVALID_REAL`. Intended to be overloaded by member functions of derived classes.

`pair<real, real> solve (char axis_unknown, real known)` [const inline virtual function]

Returns a `pair<real, real>` with `first = second = INVALID_REAL`. Intended to be overloaded by member functions of derived classes.

`signed short location (Point ref_pt, Point p)` [const virtual function]

Returns a `signed short` indicating the location of *p* with respect to the `Reg_C1_Plane_Curve`, which must be planar. The `Reg_C1_Plane_Curve` constructors should ensure that `Reg_C1_Plane_Curves` are, but there is no guarantee that they will not have been manipulated into a non-planar state, by shearing, for example.

The argument *ref\_pt* is used within the function for shifting a copy of the `Reg_C1_Plane_Curve` to a convenient position. It need not be the |center| of the `Reg_C1_Plane_Curve`, however, classes derived from `Reg_C1_Plane_Curve` will probably have their own versions of `location()`, which will pass *center* as the *ref\_pt* argument to this function. `Reg_C1_Plane_Curves` need not have a meaningful |center|.

`location()` returns the following values:

- 1 *p* and `*this` are coplanar, and *p* lies outside the perimeter of `*this`.
- 0 *p* and `*this` are coplanar, and *p* lies on the perimeter of `*this`.
- 1 *p* and `*this` are coplanar, and *p* lies inside the perimeter of `*this`.
- 2 *p* and `*this` are not coplanar.
- 3 Something has gone terribly wrong.
- 4 The normal to `*this` has 0 magnitude, i.e., the |Points| on `*this` are colinear.
- 5 An error occurred in putting `*this` in one of the major planes.

`Point angle_point (real angle)` [Virtual function]

Returns `INVALID_POINT`. Intended to be overloaded by member functions of derived classes.

### 30.3 Intersections

`bool_point_pair intersection_points (Point ref_pt, Point p0, Point p1)` [const function]

`bool_point_pair intersection_points (const Point& ref_pt, const Path& p)` [const function]

The version of this function taking `Point` arguments finds the intersection points, if any, of the `Reg_C1_Plane_Curve` and the line *p* that passes through the `Points` *p*<sub>0</sub> and *p*<sub>1</sub>. In the other version, the `Path` argument must be a linear `Path`, and its

first and last `Points` are passed to the first version of this function as `p0` and `p1`, respectively.

Let `C` be the `Reg_C1_Plane_Curve`. `C` and `p` can intersect at at most two intersection points  $i_1$  and  $i_2$ . Let `bpp` be the return value of this function. The intersection points need not be on the *line segment* between `pt0` and `pt1`. `bpp.first.pt` will be set to the first intersection point if it exists, or `INVALID_POINT` if it doesn't. If the first intersection point exists and is on the line segment between `pt0` and `pt1`

In Fig. 154, the line  $\overrightarrow{AB}$  is normal to the `Ellipse` `e`, or, to put it another way,  $\overrightarrow{AB}$  is perpendicular to the plane of `e`. The intersection point  $i_0$  lies within the perimeter of `e`.

The line  $\overrightarrow{DE}$  is skew to the plane of `e`, and intersects `e` at  $i_1$ , on the perimeter of `e`.

```
Point p0(2, 2, 3);
Ellipse e(p0, 3, 4, 30, -60, -5.2);
Point p1 = p0.mediate(e.get_point(11), .5);
Point A = e.get_normal();
A *= 2.5;
A.shift(p1);
Point B = A.mediate(p1, 2);
bool_point_pair bpp = e.intersection_points(A, B);
Point C(0, 2, 0);
Point D(0, -3.5, 0);
C *= D.rotate(2, 0, -5);
C *= D.shift(e.get_point(4));
bpp = e.intersection_points(C, D);
```

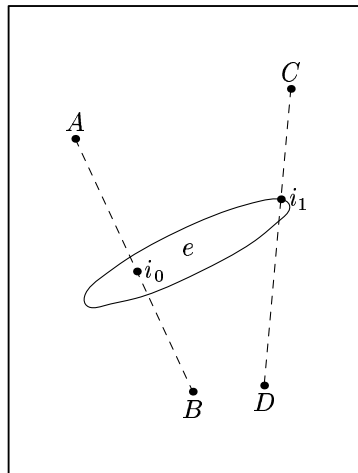

Figure 154.

In Fig. 155, `q` and `e` are coplanar. In this case, only the intersections of `q` with the perimeter of `e` are returned by `intersection_points()`.

```
A = p0.mediate(e.get_point(3), 1.5);
B = p0.mediate(e.get_point(11), 1.5);
Path q(A, B);
bpp = e.intersection_points(q);
```

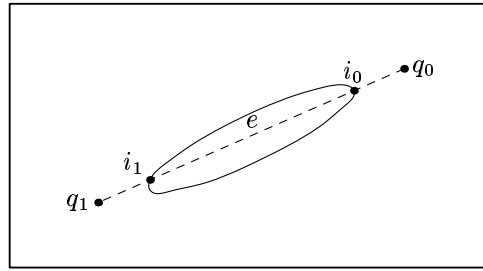

Figure 155.

## 30.4 Segments

Path **segment** (unsigned int *factor*, [real *angle* = 0, [bool *closed* = true]] [const function])

Returns a Path representing a segment of the `Reg_C1_Plane_Curve`. *factor* must be  $> 1$  and  $\leq$  `number_of_points`. If it is not, an error message is issued and an empty Path is returned.

If *angle* is non-zero, the segment Path is rotated by *angle* about a line from `center` in the direction of the normal to the plane of the `Reg_C1_Plane_Curve`. Please note, that a `Reg_C1_Plane_Curve` must have a meaningful `center`, in order for rotation to work. If the absolute value of *angle*  $> 360$ , a warning is issued, and `fmod(angle, 360)` is used.

If *closed* is true, the Path will be a cycle, with the ends of the curved segment joined using the connector '--'. The curved segment is joined to the line using '&' on each side.

```
Circle c(origin, 4, 30, 30, 30);
Path p = c.segment(3, 130);
p.show("p:");
└ p:
points.size() == 8
connectors.size() == 8(-0.00662541, -0.888379, -1.79185) ..
(0.741088, -0.673392, -1.73128) ..
(1.37598, -0.355887, -1.40714) ..
(1.80139, 0.0157987, -0.868767) ..
(1.95255, 0.385079, -0.198137) .. (1.80646, 0.695735, 0.502658) &
(1.80646, 0.695735, 0.502658) --
(-0.00662541, -0.888379, -1.79185) & cycle;
```

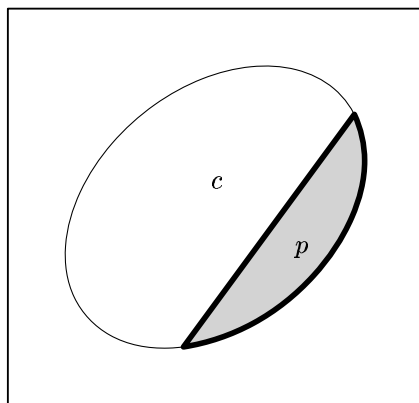

Figure 156.

Path **half** ([real *angle* = 0, [bool *closed* = true]]) [const inline function]  
 Returns a Path using half of the Points on the Reg\_C1\_Plane\_Curve. The effect of the arguments *angle* and *closed* is similar to that in `segment()`, above.

```
Ellipse e(origin, 3, 5, 20, 15, 12.5);
Path p = e.half(0, false);
```

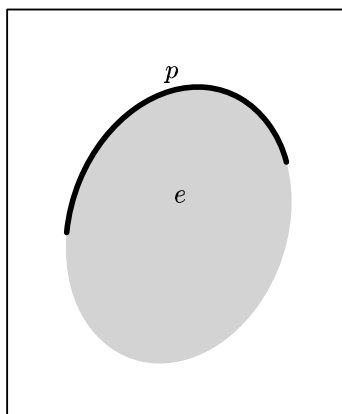

Figure 157.

Path **quarter** ([real *angle* = 0, [bool *closed* = true]]) [const inline function]  
 Returns a Path using a quarter of the Points on the Reg\_C1\_Plane\_Curve. The effect of the arguments *angle* and *closed* is similar to that in `segment()`, above.

```
Ellipse e(origin, 3, 5, 60, 5, 2.5);
Path p = e.quarter(180, false);
```

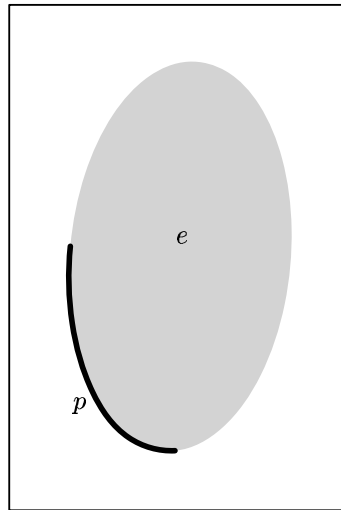

Figure 158.



## 31 Ellipse Reference

Class `Ellipse` is defined in ‘`ellipses.web`’. It is derived from `Reg_C1_Plane_Curve` using public derivation.

### 31.1 Data Members

`Point focus0` [Protected variables]

`Point focus1`

The foci of the `Ellipse`. They are located on the major axis of the `Ellipse` at a distance of `linear_eccentricity` from `center`, on opposite sides of the minor axis.

`real linear_eccentricity` [Protected variable]

The linear eccentricity of the `Ellipse`  $e$ , such that  $e = \sqrt{a^2 - b^2}$ , where  $a$  and  $b$  are half the lengths of the major and minor axes, respectively. Let  $h$  stand for `axis_h` and  $v$  for `axis_v`. If  $h > v$ , then  $a = h/2$  and  $b = v/2$ . If  $v > h$ , then  $a = v/2$  and  $b = h/2$ . If  $h = v$ , then the `Ellipse` is circular (but not an object of type `Circle!`), and  $a = b = v/2 = h/2$ .

The linear eccentricity is the distance along the major axis of the `Ellipse` from `center` to `focus0` and `focus1`.

`real numerical_eccentricity` [Protected variable]

The numerical eccentricity  $\epsilon$  of the `Ellipse`, such that  $\epsilon = e/a < 1$ , where  $e$  is the linear eccentricity of the `Ellipse`, and  $a$  is half the length of the major axis of the `Ellipse`.

`real axis_h` [Protected variables]

`real axis_v`

The horizontal and vertical axes, respectively, of the `Ellipse`.

Actually, they are only or vertical horizontal by convention, since there are no restrictions on the orientation of an `Ellipse`.

`unsigned short` [Protected static variable]

**DEFAULT\_NUMBER\_OF\_POINTS**

The number of `Points` on an `Ellipse`, unless another number is specified when an `Ellipse` constructor is invoked.

### 31.2 Constructors and Setting Functions

`void Ellipse (void)` [Default constructor]

Creates an empty `Ellipse`.

`void Ellipse (const Point& ccenter, const real aaxis_h, const real aaxis_v, [const real angle_x = 0, [const real angle_y = 0, [const real angle_z = 0, [const unsigned short nnumber_of_points = DEFAULT_NUMBER_OF_POINTS]]])` [Constructor]

Creates an `Ellipse` in the x-z plane, centered at the origin, with its horizontal axis  $\equiv$  `aaxis_h` and its vertical axis  $\equiv$  `aaxis_v`. If any of the arguments `angle_x`, `angle_y`,

or *angle\_z* is non-zero, the `Ellipse` is rotated about the x, y, and z-axis in that order, by the amounts indicated by the corresponding arguments. Finally, the `Ellipse` is shifted such that its center comes to lie at *ccenter*.

```
Ellipse e(origin, 6, 4);  
e.draw();
```

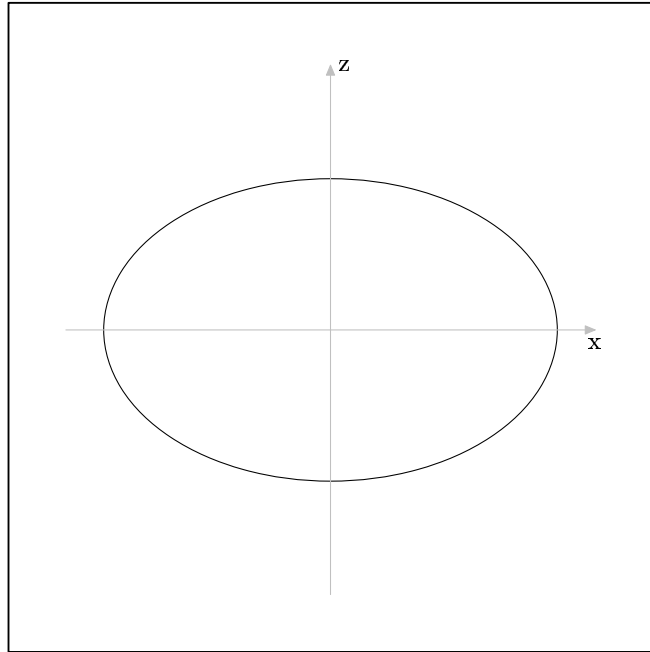

Figure 159.

```
Point P(1, 1, 1);  
Ellipse e(P, 6, 4, 15, 12, 11);  
e.draw();
```

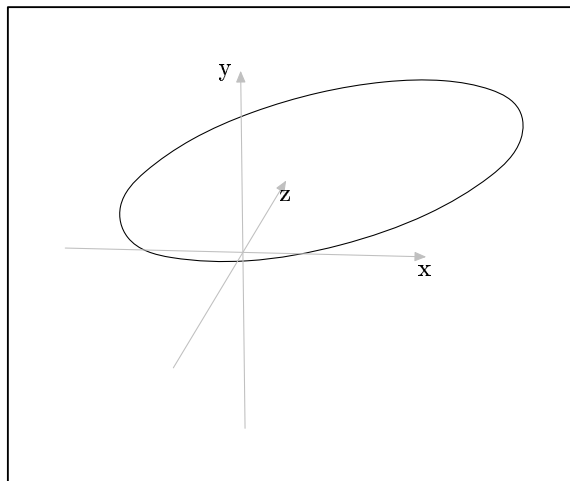

Figure 160.

```
void set (const Point& ccenter, const real axis_h, const [Setting function]
        real axis_v, [const real angle_x = 0, [const real angle_y = 0, [const
        real angle_z = 0, [const unsigned short nnumber_of_points =
        DEFAULT_NUMBER_OF_POINTS]]]])
```

Corresponds to the constructor above.

```
Ellipse* create_new<Ellipse> (const Ellipse* e) [Template specializations]
Ellipse* create_new<Ellipse> (const Ellipse& e)
```

Pseudo-constructors for dynamic allocation of `Ellipses`. They create a `Ellipse` on the free store and allocate memory for it using `new(Ellipse)`. They return a pointer to the new `Ellipse`.

If `e` is a non-zero pointer or a reference, the new `Ellipse` will be a copy of `e`. If the new object is not meant to be a copy of an existing one, '0' must be passed to `create_new<Ellipse>()` as its argument. See Chapter 14 [Dynamic Allocation of Shapes], page 83, for more information.

### 31.3 Performing Transformations

```
Transform do_transform (const Transform& t, [bool check = [Virtual function]
        false])
```

Performs a transformation on an `Ellipse`. The `Points` on the `Ellipse` are multiplied by `t`. Then, if `check` is `true`, `is_elliptical()` is called on the `Ellipse`. If the transformation has caused it to become non-elliptical, `axis_h` and `axis_v` are set to `INVALID_REAL`, and a warning is issued to `stderr`. `center`, `focus0`, and `focus1` are not set to `INVALID_POINT`. They may may no longer really be the center and foci of the (non-elliptical) `Ellipse`, but they may have some use for the programmer and/or user.

If `check` is `true`, and the transformation does not cause `*this` to become non-elliptical, `axis_h`, `axis_v`, `linear_eccentricity`, `numerical_eccentricity`, `focus0`, and `focus1` are recalculated.

### 31.4 Operators

```
Ellipse& operator= (const Ellipse& e) [Assignment operator]
    Makes the Ellipse a copy of e.
```

```
Transform operator*= (const Transform& t) [Virtual function]
    Calls do_transform(t, true), and returns the latter's return value. See Section 31.3
    [Ellipse Reference; Performing Transformations], page 223.
```

### 31.5 Labeling

```
void label ([const string pos = "top", [const bool dot = [const function]
        false, [Picture& picture = current_picture]])
```

Labels the `Points` on `points`, using lowercase letters. `pos` is used to position all of the labels. It is currently not possible to have different positions for the labels.

```

Ellipse e(origin, 6, 4);
e.draw();
e.label();

```

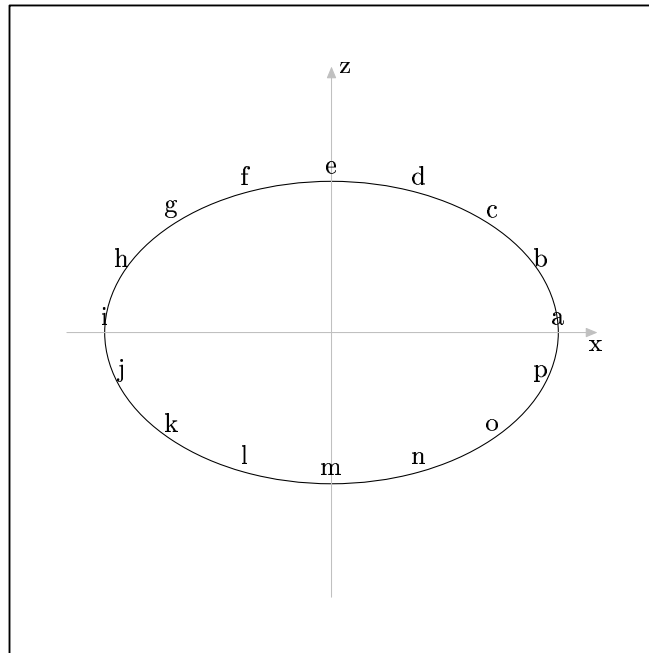

Figure 161.

```

void dotlabel ([string pos = "top", [Picture& picture = [Inline const function]
                current_picture]])
    Like label(), except that the Points are dotted.

```

```

Ellipse e(origin, 6, 4);
e.draw();
e.dotlabel();

```

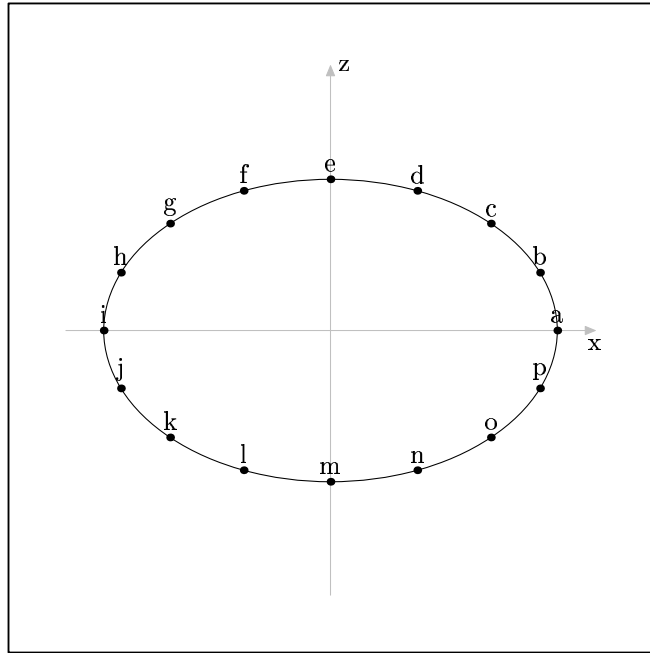

Figure 162.

## 31.6 Affine Transformations

|                                                                                                            |                    |
|------------------------------------------------------------------------------------------------------------|--------------------|
| Transform <b>rotate</b> (const real x, [const real y = 0, [const real z = 0]])                             | [Virtual function] |
| Transform <b>rotate</b> (const Point& p0, const Point& p1, [const real angle = 180])                       | [Virtual function] |
| Transform <b>rotate</b> (const Path& p, [const real angle = 180])                                          | [Virtual function] |
| Transform <b>scale</b> (real x, [real y = 1, [real z = 1]])                                                | [Virtual function] |
| Transform <b>shear</b> (real xy, [real xz = 0, [real yx = 0, [real yz = 0, [real zx = 0, [real zy = 0]]]]) | [Virtual function] |
| Transform <b>shift</b> (real x, [real y = 0, [real z = 0]])                                                | [Virtual function] |
| Transform <b>shift</b> (const Point& p)                                                                    | [Virtual function] |
| void <b>shift_times</b> (real x, [real y = 1, [real z = 1]])                                               | [Virtual function] |
| void <b>shift_times</b> (const Point& p)                                                                   | [Virtual function] |

These create a `Transform t` locally, and call `do_transform(t)`. See Section 31.3 [Ellipse Reference; Performing Transformations], page 223.

Rotating and shifting an `Ellipse` neither change the size of an `Ellipse`, nor cause it to become non-elliptical. However, scaling and shearing can have these effects. For this reason, in `scale()` and `shear()`, `do_transform()` is called with `true` as its *check* argument, while it is `false` in `rotate()`, `shift()`, and `shift_times()`.

If scaling or shearing is performed on an `Ellipse`, and it is still elliptical after the transformation, `focus0`, `focus1`, `axis_h`, `axis_v`, `linear_eccentricity`, and `numerical_eccentricity` are all recalculated. If the `Ellipse` is non-elliptical after the transformation, `axis_h`, `axis_v`, `linear_eccentricity`, and `numerical_eccentricity` are all set to `INVALID_REAL`. `center`, `focus0`, and `focus1` are not set to `INVALID_POINT`. Although they are no longer the center and foci of an elliptical `Ellipse`, they may still have some use for the user or programmer.

## 31.7 Querying

`bool is_elliptical (void)` [const function]

Returns `true` if the `Ellipse` is elliptical, otherwise `false`.

Certain transformations, such as shearing and scaling, can cause `Ellipses` to become non-elliptical.

`bool is_quadratic (void)` [Inline const function]

Returns `true`, because the equation for an ellipse in the x-y plane with its center at the origin is the quadratic equation

$$x^2/a^2 + y^2/b^2 = 1$$

where  $a$  is half the horizontal axis and  $b$  is half the vertical axis.

```
Ellipse e(origin, 5, 2, 90);
e.draw();
Point P(e.angle_point(-35));
cout << ((P.get_x() * P.get_x())
         / (e.get_axis_h()/2 * e.get_axis_h()/2))
      + ((P.get_y() * P.get_y())
         / (e.get_axis_v()/2 * e.get_axis_v()/2));
+ 1
```

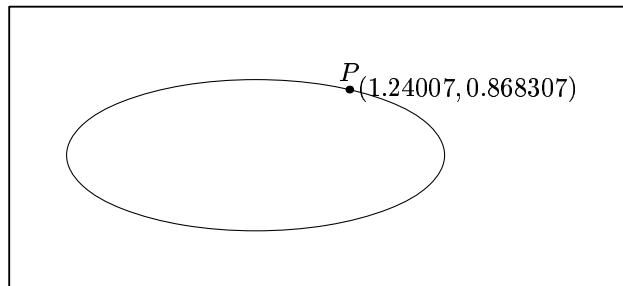

Figure 163.

`bool is_cubic (void)` [const virtual functions]

`bool is_quartic (void)`

These functions both return `false`, because the equation of an ellipse is neither a cubic nor a quartic function.

## 31.8 Returning Elements and Information

`Point& get_center (void)` [Virtual function]

`Point get_center (void)` [const virtual function]

These functions return `center`.

`const Point& get_focus (const unsigned short s)` [Function]

`Point get_focus (const unsigned short s)` [const function]

These functions return `focus0` or `focus1`, depending on the value of  $s$ , which must be 0 or 1. If  $s$  is not 0 or 1, `get_focus()` returns `INVALID_POINT`.

`real get_linear_eccentricity (void)` [const function]  
Returns `linear_eccentricity`.

`real get_numerical_eccentricity (void)` [const function]  
Returns `numerical_eccentricity`.

`real get_axis_v (void)` [Function]

`real get_axis_v (void)` [const function]  
Calculates and returns the value of `axis_h`.

`get_axis_v()` first checks if the `Ellipse` is still elliptical, using `is_elliptical()` (see Section 31.7 [Ellipse Reference; Querying], page 226). Operations such as `scale()` and `shear()` can cause an `Ellipse` to become non-elliptical. If this is the case, this function returns `INVALID_REAL`.

If the `Ellipse` is still elliptical, `axis_v` is recalculated and returned. In the non-`const` version, `axis_v` is also reset to the new value.

`real get_axis_h (void)` [Function]

`real get_axis_h (void)` [const function]  
Calculates and returns the value of `axis_h`.

`get_axis_h()` first checks if the `Ellipse` is still elliptical, using `is_elliptical()` (see Section 31.7 [Ellipse Reference; Querying], page 226). Operations such as `scale()` and `shear()` can cause an `Ellipse` to become non-elliptical. If this is the case, this function returns `INVALID_REAL`.

If the `Ellipse` is still elliptical, `axis_h` is recalculated and returned. In the non-`const` version, `axis_h` is also reset to the new value.

`signed short location (Point p)` [const virtual function]

Returns a value `l` indicating the location of the `Point` argument `p` with respect to the `Ellipse`.

Let `e` stand for the `Ellipse`. The return values are as follows:

- 0            `p` lies on the perimeter of `e`.
- 1            `p` lies in the plane of `e`, within its perimeter.
- 1           `p` lies in the plane of `e`, outside its perimeter.
- 2           `p` and `e` do not lie in the same plane.
- 3           `e` is not elliptical, possibly due to having been transformed.

```
Ellipse e(origin, 3, 5, 45, 15, 3);
e.shift(2, 1, 1);
Point A = e.get_point(7);
cout << e.location(A);
+ 0
Point B = center.mediate(e.get_point(2));
cout << e.location(B);
+ 1
Point C = center.mediate(e.get_point(2), 1.5);
cout << e.location(C);
```

```

-| -1
Point D = A;
D.shift(-2, 0, 4);
e.location(D);
-| WARNING! In Ellipse::location():
   Point doesn't lie in plane of Ellipse.
   Returning -2.
e.scale(1.5, 0, 1.5);
e.location(A);
-| WARNING! In Ellipse::do_transform(const Transform&):
   This transformation has made *this non-elliptical!

ERROR! In Ellipse::location():
  Ellipse is non-elliptical. Returning -3.

```

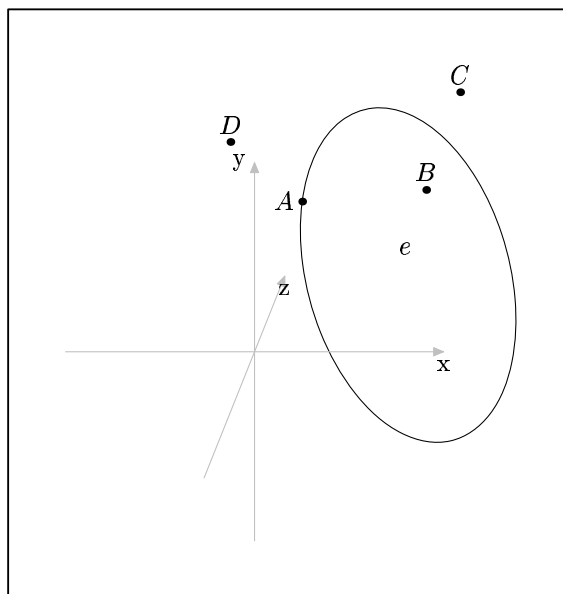

Figure 164.

**Point** **angle\_point** (real *angle*) [const function]

Returns a point on the **Ellipse** given an angle. A **Point** *p* is set to the zeroth **Point** on the **Ellipse** and rotated about the line from the center of the **Ellipse** in the direction of the normal to the plane of the **Ellipse**. Then, the intersection of the ray from the center through *p* and the perimeter of the **Ellipse** is returned.

```

Ellipse e(origin, 6, 4);
Point P = e.angle_point(135);
current_picture.output(Projections::PARALLEL_X_Z);

```



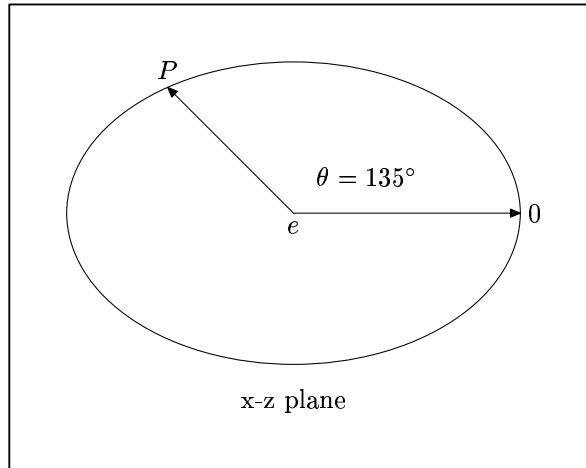

Figure 165.

Fig. 166 demonstrates, that the rotation is unfortunately not always in the direction one would prefer. I don't have a solution to this problem yet.

```
Ellipse e(origin, 6, 4, 90);
Point P = e.angle_point(135);
Point Q = e.angle_point(-135);
```

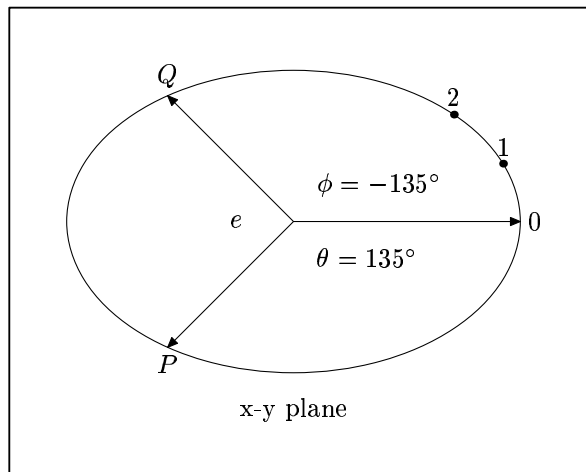

Figure 166.

## 31.9 Intersections

```
bool_point_pair intersection_points (const Point& p0, const Point& p1) [const virtual function]
```

```
bool_point_pair intersection_points (const Path& p) [const virtual function]
```

These functions return the intersection points of a line with an `Ellipse`. In the first version, the line is specified by the two `Point` arguments. In the second version, `p.is_linear()` must return `true`, otherwise, `intersection_points()` issues an error message and returns `INVALID_BOOL_POINT_PAIR`.

If the line and the `Ellipse` are coplanar, there can be at most two intersection points. Otherwise, there can be at most one.

```
Ellipse e(origin, 5, 7, 30, 30, 30);
```

```

e.shift(3, 0, 3);
Point p0 = e.get_center().mediate(e.get_point(3));
Point normal = e.get_normal();
Point A = normal;
A *= 2.5;
A.shift(p0);
Point B = normal;
B *= -2.5;
B.shift(p0);
bool_point_pair bpp = e.intersection_points(A, B);
bpp.first.pt.dotlabel("$i_0$", "rt");
Point C = e.get_point(15).mediate(e.get_point(11), 1.25);
Point D = e.get_point(11).mediate(e.get_point(15), 1.5);
Path q = C.draw(D);
bpp = e.intersection_points(q);
bpp.first.pt.dotlabel("$i_1$", "llft");
bpp.second.pt.dotlabel("$i_2$", "ulft");

```

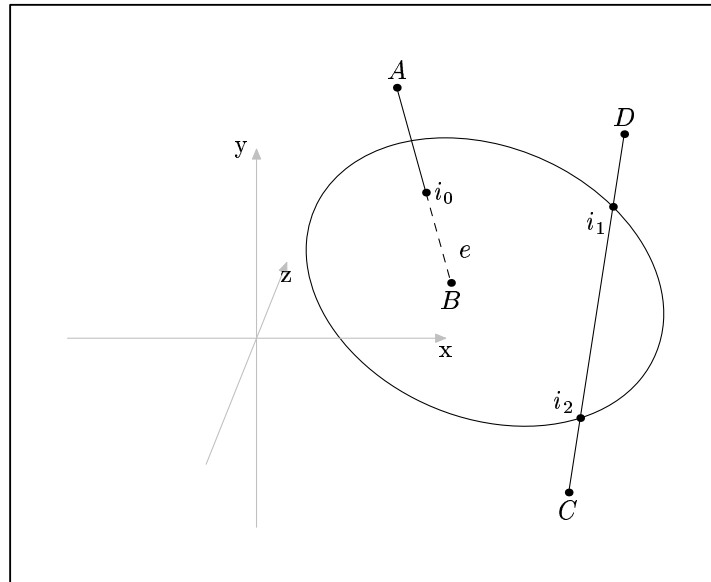

Figure 167.

**bool\_point\_quadruple intersection\_points** (Ellipse [const virtual function] e, [const real step = 3, [bool verbose = false]])

Returns the intersection points of two Ellipses. Two Ellipses can intersect at at most four points.

Let *bpq* be the **bool\_point\_quadruple** returned by **intersection\_points()**. If one or more intersection points are found, the corresponding Points are stored in the **pt** elements of the four **bool\_points** belonging to *bpq*, otherwise **INVALID\_POINT**. If a Point is found, the **b** element of the **bool\_point** will be **true**, otherwise **false**.

The *step* argument is used when the Ellipses are coplanar and either have different centers or the vertical axis of one Ellipse is colinear with the horizontal axis of the other (and vice versa). In these cases, the intersection points must be found by an

iterative routine. A `Point p` travels around the perimeter of `*this`, and its location with respect to `e` is tested. `step` is the angle of rotation used for stepping around the perimeter of `*this`. The default value, 3, should be adequate, unless the `Ellipses` differ greatly in size.

If the `verbose` argument is `true`, `intersection_points()` will print information about the intersection points to standard output.

In Fig. 168, the `Ellipses` `e` and `f` both lie in the x-z plane, are centered at the origin, and intersect at four points.

```
Ellipse e(origin, 5, 2);
Ellipse f(origin, 2, 5);
bool_point_quadruple bpq = e.intersection_points(f);
bpq.first.pt.dotlabel(1, "l1ft");
bpq.second.pt.dotlabel(2, "urt");
bpq.third.pt.dotlabel(3, "ulft");
bpq.fourth.pt.dotlabel(4, "lrt");
```

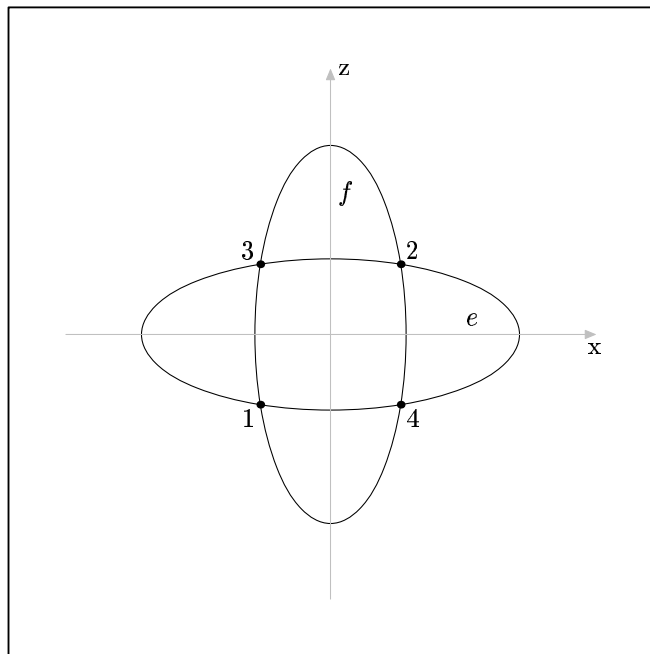

Figure 168.

In Fig. 169, `e` and `f` are coplanar, but don't lie in a major plane, have different centers, and only intersect at two points.

```
Ellipse e(origin, 4, 2);
Ellipse f(origin, 2, 5);
f.shift(0, 0, 1);
f.rotate(0, 15);
f.shift(1, 0, 1);
e *= f.shift(-.25, 1, -1);
e *= f.rotate(10, -12.5, 3);
bool_point_quadruple bpq = e.intersection_points(f, true);
bpq.first.pt.dotlabel(1, "urt");
```

```
bpq.second.pt.dotlabel(2, "ulft");
```

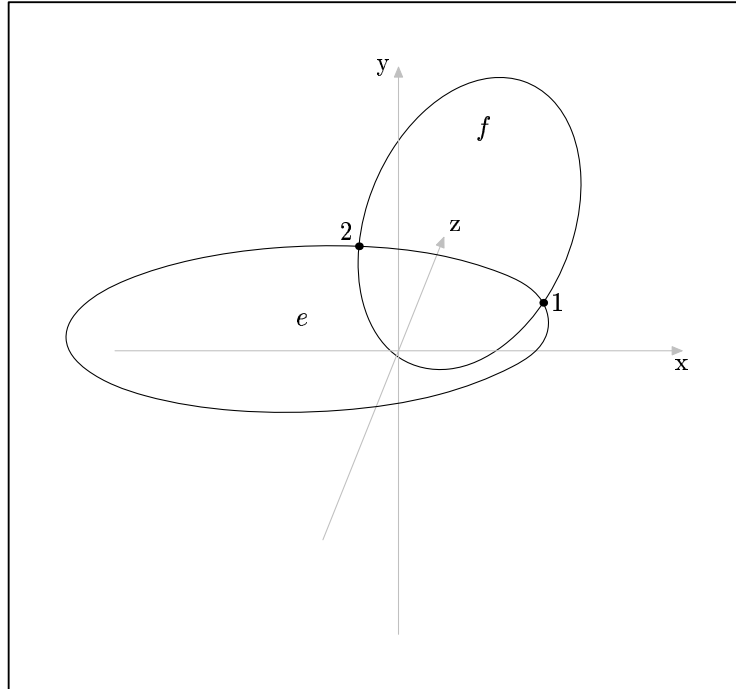

Figure 169.

If the planes of the `Ellipses` are parallel, there are, of course, no intersection points. If the `Ellipses` are non-coplanar, and their planes are not parallel to each other, `intersection_points()` first finds the line of intersection of the planes of the `Ellipses`. It then returns the `Points` of intersection of this line with the `Ellipses`, if they exist. If the `verbose` argument is `true`, information about the `Points` is printed to standard output.

In Fig. 170, the two `Ellipses` lie in skew planes. The plane of `f` intersects with `e` at the `Points` labelled “1” and “2”, while the plane of `e` intersects with `f` at the `Points` labelled “3” and “4”.

```
Ellipse e(origin, 5, 3);
Ellipse f(origin, 2, 5);
f.rotate(0, 0, 30);
f.rotate(0, 10);
f.rotate(45);
f.shift(1.5, 1);
bool_point_quadruple bpq = e.intersection_points(f, true);
bpq.first.pt.dotlabel(1);
bpq.second.pt.dotlabel(2);
bpq.third.pt.dotlabel(3, "rt");
bpq.fourth.pt.dotlabel(4, "urt");
- First point lies on the perimeter of *this.
  First point lies inside e.
  Second point lies on the perimeter of *this.
  Second point lies outside e.
```

Third point lies outside \*this.  
 Third point lies on the perimeter of e.  
 Fourth point lies inside \*this.  
 Fourth point lies on the perimeter of e.

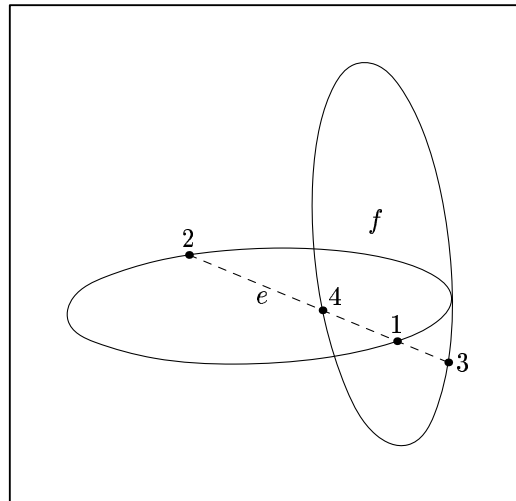

Figure 170.

In Fig. 171, the two Ellipses lie in skew planes. The plane of *f* intersects with *e* at the Points labelled “1” and “2”. The plane of *e* does not intersect with *f*, so `bpq.third.pt` and `bpq.fourth.pt` are `INVALID_POINT`.

```
Ellipse e(origin, 5, 3);
Ellipse f(origin, 2, 5, 45);
f.shift(0, 2.5, 3);
bool_point_quadruple bpq = e.intersection_points(f, true);
bpq.first.pt.dotlabel(1);
bpq.second.pt.dotlabel(2);
-| First point lies on the perimeter of *this.
   First point lies outside e.
   Second point lies on the perimeter of *this.
   Second point lies outside e.
   Third intersection point is INVALID_POINT.
   Fourth intersection point is INVALID_POINT.
```

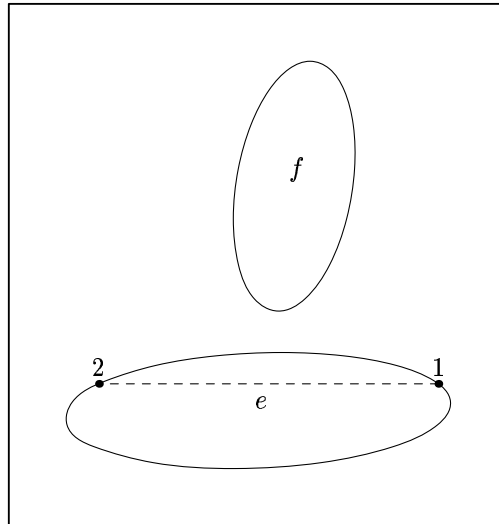

Figure 171.

### 31.10 Solving

**real\_pair solve** (char *axis\_unknown*, real *known*) [const function]

Returns two possible values for either the horizontal or vertical coordinate. This function assumes that the `Ellipse` lies in a major plane with `center` at the origin. Code that calls it must ensure that these conditions are fulfilled.

`solve()` is called in `Reg_C1_Plane_Curve::intersection_points(Point, Point, Point)` and `Reg_C1_Plane_Curve::location()`, and resolves to this function, when these functions are called on an `Ellipse`. However, `Ellipse::location()` overloads `Reg_C1_Plane_Curve::location()`, so the latter won't normally be called on an `Ellipse`. See Section 30.3 [Regular Closed Plane Curve Reference; Intersections], page 216, and Section 30.2 [Regular Closed Plane Curve Reference; Querying], page 215.

**real\_triple get\_coefficients** (real *Slope*, real *v\_intercept*) [const function]

Let  $x$  and  $y$  stand for the x and y-coordinates of a point on an ellipse in the x-y plane,  $a$  for half of the horizontal axis (`axis_h/2`), and  $b$  for half of the vertical axis (`axis_v/2`).

Further, let  $y = mx + i$  be the equation of a line in the x-y plane, where  $m$  is the slope and  $i$  the y-intercept.

This function returns the coefficients of the quadratic equation that results from replacing  $y$  with  $mx + i$  in the equation for the ellipse

$$x^2/a^2 + y^2/b^2 = 1$$

namely

$$\begin{aligned} x^2/a^2 + (mx + i)^2/b^2 - 1 &= 0 \\ \equiv (b^2x + a^2m^2)x^2 + 2a^2imx + (a^2i^2 - a^2b^2) &= 0. \end{aligned}$$

The coefficients are returned in the `real_triple` in the order one would expect: `r.first` is the coefficient of  $x^2$ , `r.second` of  $x$  and `r.third` of the constant term ( $x^0 \equiv 1$ ).

`get_coefficients()` is called in `Reg_C1_Plane_Curve::intersection_points(Point, Point, Point)`, and resolves to this function, when the latter is called on an `Ellipse`. See Section 30.3 [Regular Closed Plane Curve Reference; Intersections], page 216.

### 31.11 Rectangles

Rectangle `out_rectangle` (void) [const function]

Returns the Rectangle that surrounds the Ellipse.

```
Ellipse e(origin, 3, 4, 45, 30, 17);
e.shift(1, -1, 2);
Rectangle r = e.out_rectangle();
r.filldraw(black, gray);
e.unfilldraw(black);
```

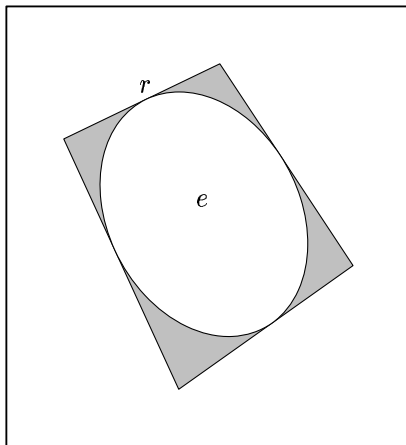

Figure 172.

Rectangle `in_rectangle` (void) [const function]

Returns the Rectangle enclosed within the Ellipse.

```
Rectangle r = e.in_rectangle();
e.filldraw(black, gray);
r.unfilldraw(black);
```

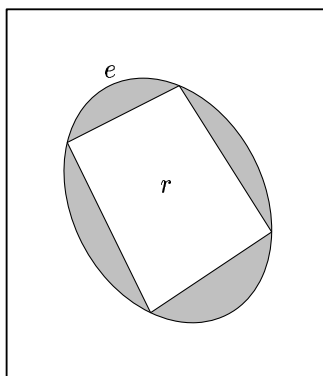

Figure 173.

Rectangle **draw\_out\_rectangle** ([const Color& *ddraw\_color* = [const function] \*Colors::default\_color, [string *ddashed* = "", [string *ppen* = "", [Picture& *picture* = current\_picture]]]])

Draws the Rectangle that surrounds the Ellipse. The arguments are like those of Path::draw(). The return value is the surrounding Rectangle. See Section 26.12 [Path Reference; Drawing and Filling], page 179.

```
Ellipse e(origin, 2.5, 5, 10, 12, 15.5);
e.shift(-1, 1, 1);
e.draw_out_rectangle(black, "evenly", "pencircle scaled .3mm");
```

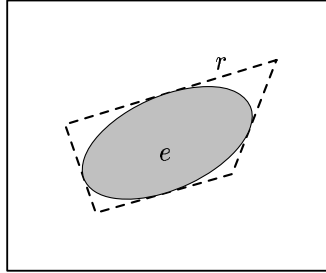

Figure 174.

Rectangle **draw\_in\_rectangle** ([const Color& *ddraw\_color* = [const function] \*Colors::default\_color, [string *ddashed* = "", [string *ppen* = "", [Picture& *picture* = current\_picture]]]])

Draws the Rectangle enclosed within the Ellipse. The arguments are like those of Path::draw(). The return value is the enclosed Rectangle. See Section 26.12 [Path Reference; Drawing and Filling], page 179.

```
Ellipse e(origin, 3.5, 6, 10, 12, 15.5);
e.shift(-1, 1, 1);
e.draw_in_rectangle(black, "evenly", "pencircle scaled .3mm");
```

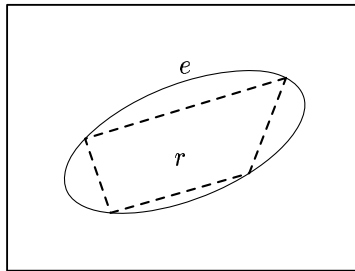

Figure 175.



## 32 Circle Reference

Class `Circle` is defined in `'circles.web'`. It is derived from `Ellipse`, using public derivation.

Since `Circle` is just a special kind of `Ellipse`, there is often no need to define special functions for `Circles`.

Currently, `Circle` inherits the transformation functions and `operator*=(const Transform&)` from `Ellipse`. Consequently, the data member `radius`, described below, is not recalculated, when transformations are performed on a `Circle`. I plan to change this soon!

### 32.1 Data Members

`real radius` [Private variable]  
The radius of the `Circle`.

### 32.2 Constructors and Setting Functions

`void Circle (void)` [Default constructor]  
Creates an empty `Circle`.

`void Circle (const Point& ccenter, const real ddiameter, [const real angle_x = 0, [const real angle_y = 0, [const real angle_z = 0, [const unsigned short nnumber_of_points = DEFAULT_NUMBER_OF_POINTS]]]])` [Constructor]

Creates a `Circle` with `radius`  $\equiv$  `ddiameter/2` in the x-z plane and centered at the origin with `nnumber_of_points` Points. If any of the arguments `angle_x`, `angle_y`, or `angle_z` is  $\neq 0$ , the `Circle` is rotated around the major axes by the angles indicated by the arguments. Finally, the `Circle` is shifted such that `center` comes to lie at `ccenter`.

`void set (const Point& ccenter, const real ddiameter, [const real angle_x = 0, [const real angle_y = 0, [const real angle_z = 0]])` [Setting function]  
Corresponds to the constructor above.

`Circle* create_new<Circle> (const Circle* c)` [Template specializations]  
`Circle* create_new<Circle> (const Circle& c)`

Pseudo-constructors for dynamic allocation of `Circles`. They create a `Circle` on the free store and allocate memory for it using `new(Circle)`. They return a pointer to the new `Circle`.

If `c` is a non-zero pointer or a reference, the new `Circle` will be a copy of `c`. If the new object is not meant to be a copy of an existing one, `'0'` must be passed to `create_new<Circle>()` as its argument. See Chapter 14 [Dynamic Allocation of Shapes], page 83, for more information.

### 32.3 Operators

`Circle& operator= (const Circle& c)` [Assignment operator]  
Makes the `Circle` a copy of `c`.

`Circle& operator= (const Ellipse& e)` [Assignment operator]  
Makes the `Circle` a copy of `e`, if `e` is circular. `radius` is set to `e.axis_v / 2` and `*this` is returned.

If `e` is not circular, this function issues an error message and returns `*this`.

### 32.4 Querying

`bool is_circular (void)` [const function]  
Returns `true` if the `Circle` is circular, otherwise `false`.

Certain transformations, such as shearing and scaling, can cause `Circles` to become non-circular.

```
Circle c(origin, 3, 90);
cout << c.is_circular();
+ 1

Circle d = c;
d.shift(2.5);
d.scale(2, 3);
cout << d.is_circular();
+ 0
```

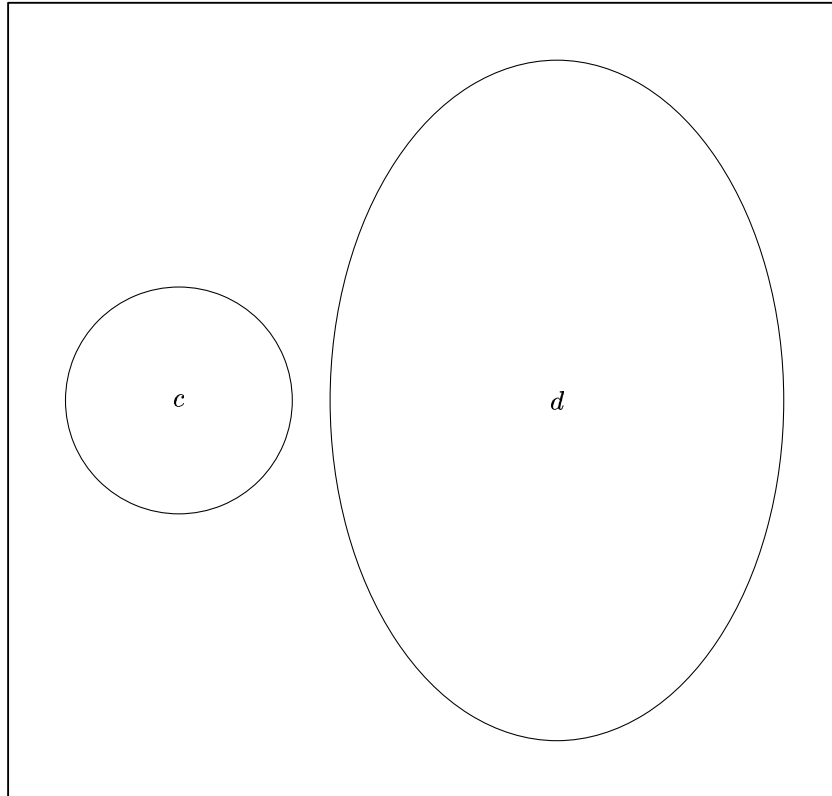

Figure 176.

`real get_radius (void)` [Inline function]  
Returns radius.

`real get_diameter (void)` [Inline function]  
Returns  $2 \times$ radius.

### 32.5 Intersections

`bool_point_quadruple intersection_points (const Circle& c, [const bool verbose = false])` [Virtual const function]

Returns the intersection points of two `Circles`.

If the `Circles` are coplanar, they can intersect at at most two points. There is an easy algebraic solution for this, so in this case, this function is faster than `Ellipse::intersection_points(Ellipse, bool)`, which uses an iterative procedure to find the points.

If the `Circles` are non-coplanar, the intersection points of each `Circle` with the plane of the other `Circle` are returned, so a maximum of four `Points` can be found.

```
Circle t(origin, 5, 90);
Circle c(origin, 3, 90);
c.shift(3);
c.rotate(0, 0, 45);
bool_point_quadruple bpq = t.intersection_points(c);
bpq.first.pt.dotlabel("$f$");
```

```
bpq.second.pt.dotlabel("$s$");
```

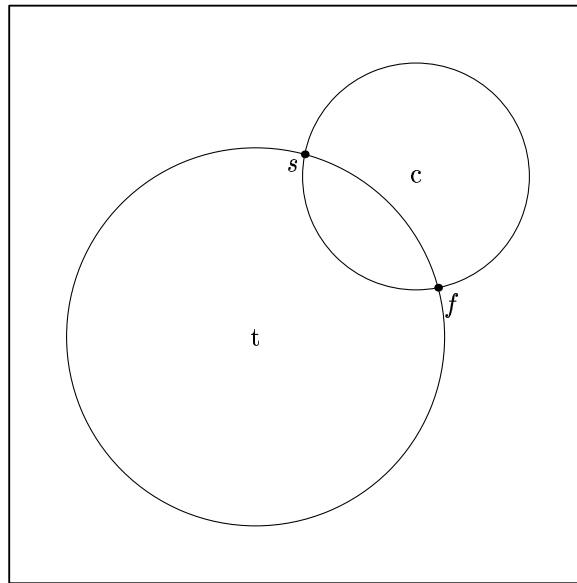

Figure 177.

## 33 Pattern Reference

There is currently no class “`Pattern`”. If it turns out to be useful for this purpose, I will define a `Pattern` class, and perhaps additional derived classes.

### 33.1 Plane Tessellations

3DLDF can be used to make perspective projections of plane tessellations and other two-dimensional patterns. These can be used for drawing tiled floors and other architectural items, among other things. While patterns can be generated by using the basic facilities of C++ and 3DLDF without any specially defined functions, it can be useful to define such functions.

3DLDF currently contains only one function for drawing patterns based on a plane tessellation. I plan to add more soon.

```
unsigned int hex_pattern_1 ([real diameter_outer = 5, [real diameter_middle = 0, [real diameter_inner = 0, [unsigned short first_row = 5, [unsigned short double_rows = 10, [unsigned short row_shift = 2, [Color draw_color_outer = *Colors::default_color, [Color fill_color_outer = *Colors::background_color, [Color draw_color_middle = *Colors::default_color, [Color fill_color_middle = *Colors::background_color, [Color draw_color_inner = *Colors::default_color, [Color fill_color_inner = *Colors::background_color, [string pen_outer = "pencircle scaled .5mm", [string pen_middle = "pencircle scaled .3mm", [string pen_inner = "pencircle scaled .3mm", [Picture& picture = current_picture, [unsigned int max_hexagons = 1000]]]]]]]]]]))
```

Draws a pattern consisting of hexagons forming a tessellation of the x-z plane, with additional hexagons within them.

The arguments:

`real diameter_outer`

Default: 5. The diameter of the outer hexagon in each set of three hexagons. The outer hexagons form a tessellation of the plane.

`real diameter_middle`

Default: 0. The diameter of the middle hexagon in a set of three hexagons.

`real diameter_inner`

Default: 0. The diameter of the inner hexagon in a set of three hexagons.

`unsigned short first_row`

Default: 5. The number of sets of hexagons in the first single row. The second single row will have `first_row + 1` sets of hexagons.

`unsigned short double_rows`

Default: 10. The number of double rows drawn.

**unsigned short** *row\_shift*

Default: 2. For *row\_shift*  $\neq$  0, the number of sets of hexagons in each (single) row is increased by 2 every *row\_shift* rows. If *row\_shift*  $\equiv$  0, the number sets of hexagons remains constant. The rows remain centered around the z-axis.

**Color** *draw\_color\_outer*

Default: `*Colors::default_color`. The **Color** used for drawing the outer hexagons.

**Color** *fill\_color\_outer*

Default: `*Colors::background_color`. The **Color** used for filling the outer hexagons.

**Color** *draw\_color\_middle*

Default: `*Colors::default_color`. The **Color** used for drawing the middle hexagon.

**Color** *fill\_color\_middle*

Default: `*Colors::background_color`. The **Color** used for filling the middle hexagons.

**Color** *draw\_color\_inner*

Default: `*Colors::default_color`. The **Color** used for drawing the inner hexagons.

**Color** *fill\_color\_inner*

Default: `*Colors::background_color`. The **Color** used for filling the inner hexagons.

**string** *pen\_outer*

Default: "pencircle scaled .5mm". The pen used for drawing the outer hexagons.

**string** *pen\_middle*

Default: "pencircle scaled .3mm". The pen used for drawing the middle hexagons.

**string** *pen\_inner*

Default: "pencircle scaled .3mm". The pen used for drawing the inner hexagons.

**Picture&** *picture*

Default: `current_picture`. The **Picture** onto which the pattern is put.

**unsigned int** *max\_hexagons*

Default: 1000. The maximum number of hexagons that will be drawn.

Draws a pattern in the x-z plane consisting of hexagons. The outer hexagons form a tessellation. The middle and inner hexagons fit within the outer hexagons. The hexagons are drawn in double rows. The tessellation can be repeated by copying a double row and shifting the copy to lie directly behind the first double row. If the **Picture** with the pattern is projected with the **Focus** in front of the pattern, looking in the direction of the back of the pattern, the first row of hexagons will appear

larger than the rows behind it. Therefore, in order for the perspective projection of the pattern to fill a rectangular area on the plane of projection, it will generally be necessary to increase the number of sets of hexagons in each double row. On the other hand, if the same number of sets of hexagons were used in the front double row, as will be needed for the back double row, many of them would probably be unprojectable.

The return value of this function is the number of hexagons drawn.

```
default_focus.set(0, 10, -10, 0, 10, 25, 10);
hex_pattern_1(1, 0, 0, 5, 5);
```

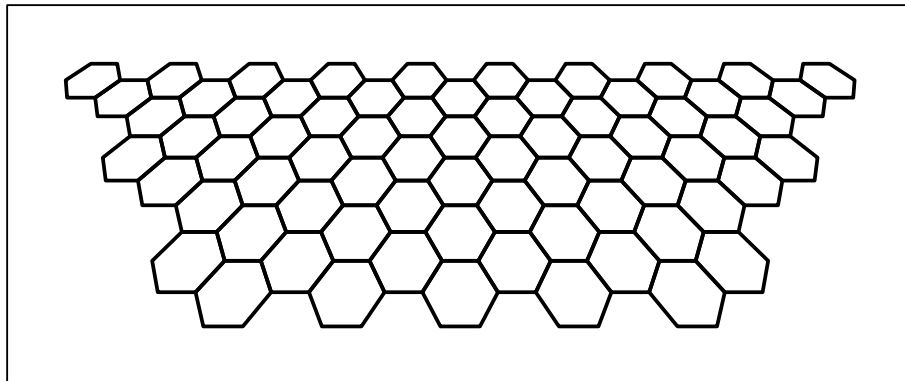

Figure 178.

```
default_focus.set(-5, 5, -10, 0, 10, 25, 10);
hex_pattern_1(2, 1.5, 1, 2, 5, 2, black, gray, black,
light_gray, black);
```

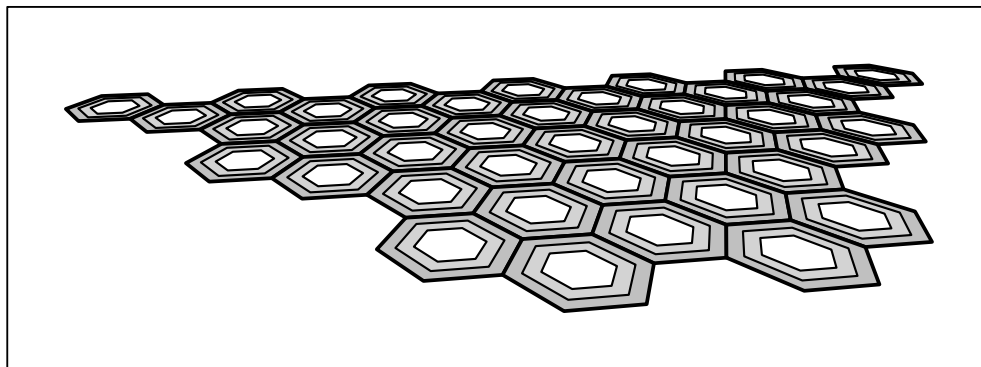

Figure 179.

## 33.2 Roulettes and Involutives

“A *roulette* is the curve generated by a point which is carried by a curve which rolls on a fixed curve. [...] The locus of a point carried by a circle rolling on a straight line is a *trochoid*. If the point is inside the circle the trochoid has inflexions; if it is outside the circle, but rigidly attached to it, the trochoid has loops. [...] In the particular case when the point is on the circumference of the rolling circle the roulette is a *cycloid*. When the circle rolls on the outside of

another circle the corresponding curves are the *epitrochoids* and *epicycloids*; if it rolls on the inside, they are the *hypotrochoids* and *hypocycloids*.”

H. Martyn Cundy and A. P. Rollett, *Mathematical Models*, p. 46.

### 33.2.1 Epicycloids

```
unsigned int epicycloid_pattern_1 (real diameter_inner, real [Function]
    diameter_outer_start, real diameter_outer_end, real step, int
    arc_divisions, unsigned int offsets, [vector<const Color*> colors =
    Colors::default_color_vector])
```

Draws a pattern consisting of epicycloids. The outer circle rolls around the circumference of the inner circle and a `Point` on the outer circle traces an epicycloid.

If *offsets* is greater than 1, the outer circle is rotated *offset* times around the center of the inner circle by  $360/\textit{offsets}$  (starting from the outer circle’s original position). From each of these new positions, an epicycloid is drawn.

While *diameter\_outer\_start* is greater than or equal to *diameter\_outer\_end*, the diameter of the outer circle is reduced by *step*, and another set of epicycloids is traced, as described above. Each time the diameter of the outer circle is reduced, a new `Color` is taken from *colors* for the drawing commands. If there are more iterations than `Colors`, the last `Color` on *colors* is used for the remaining iterations.

The arguments:

`real diameter_inner`

The diameter of the inner circle.

`real diameter_outer_start`

The diameter of the outer circle for the first iteration. It must be greater than or equal to *diameter\_outer\_end*.

`real diameter_outer_end`

The diameter of the outer circle for the last iteration. It must be less than or equal to *diameter\_outer\_start*.

`real step` The amount by which the diameter of the outer circle is *reduced* upon each iteration.

`int arc_divisions`

The number of divisions of the circle used for calculating `Points` on the epicycloid. For instance, if *arc\_divisions* is 90, then the `Path` for each epicycloid will only have 4 `Points`, since  $360/90 = 4$ .

`unsigned int offsets`

The number of epicycloids drawn upon each iteration. Each one is rotated by  $360/\textit{offsets}$  around the center of the inner circle. *offsets* must be greater than or equal to 1.

`vector<const Color*> colors`

Default: `Colors::default_color_vector`. The `Colors` pointed to by the pointers on this vector are used for drawing the epicycloids. One `Color` is used for each iteration.



Example:

```
epicycloid_pattern_1(5, 3, 3, 1, 72);  
current_picture.output(Projections::PARALLEL_X_Z);
```

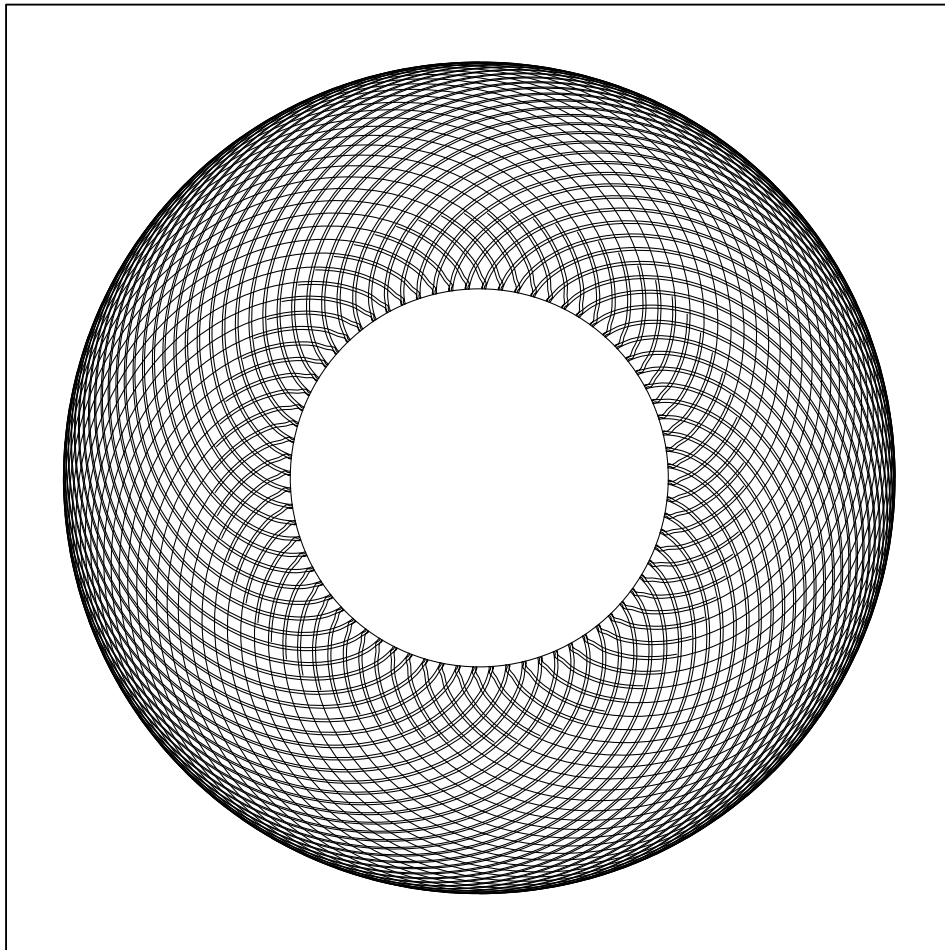

Figure 180.

Example:

```
default_focus.set(2, 5, -10, 2, 5, 10, 10);  
epicycloid_pattern_1(5, 3, 3, 1, 36);  
current_picture.output();
```

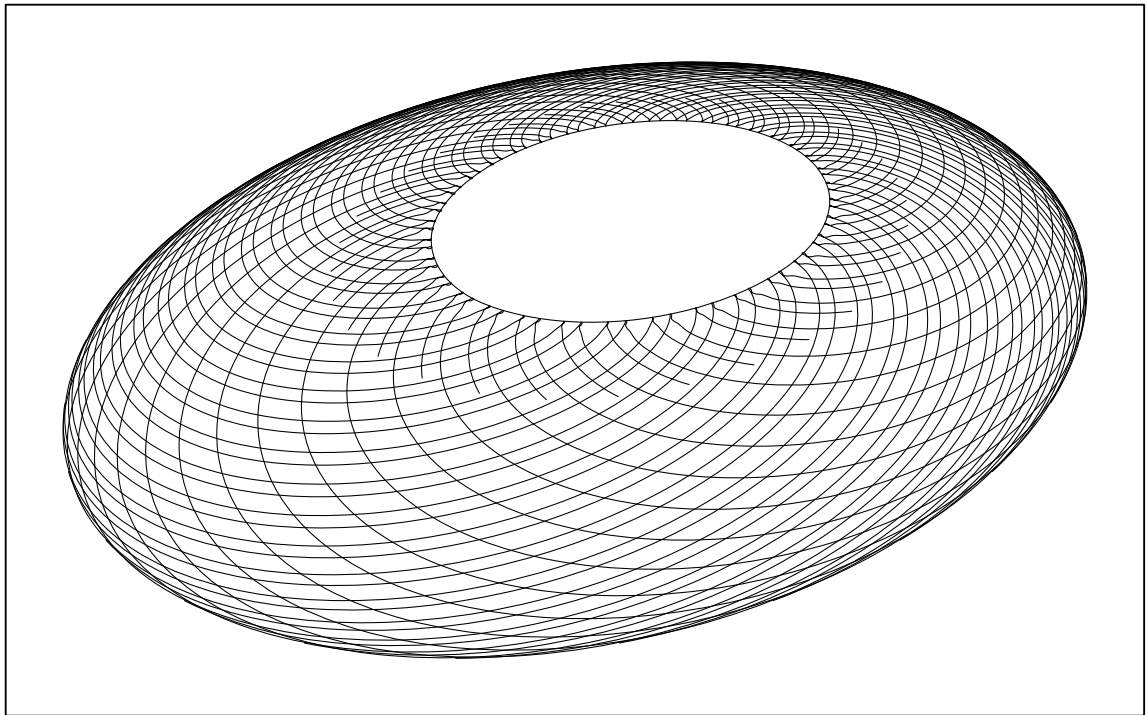

Figure 181.

## 34 Solid Reference

Class `Solid` is defined in `'solids.web'`. It's derived from `Shape` using public derivation. It is intended to be used as a base class for more specialized classes representing solid figures, e.g., cuboids, polyhedra, solids of rotation, etc.

### 34.1 Data Members

`bool on_free_store` [Protected variable]  
`true`, if the `Solid` was dynamically allocated on the free store, otherwise `false`. `Solids` should only be allocated on the free store by `create_new<Solid>()`, or analogous functions for derived classes. See Section 34.2 [Solid Reference; Constructors and Setting Functions], page 248.

`Point center` [Protected variable]  
 The center of the `Solid`. An object of a type derived from `Solid` need not have a meaningful `center`. However, many do, so it's convenient to be able to access it using the member functions of `Solid`.

`bool do_output` [Protected variable]  
 Set to `false` in `Picture::output()`, if the `Solid` cannot be projected using the arguments of that particular invocation of `output()`. Reset to `true` at the end of `Picture::output()`, so that the `Solid` will be tested for projectability again, if `output()` is called on the `Picture` again.

`vector<Path*> paths` [Protected variables]  
`vector<Circle*> circles`  
`vector<Ellipse*> ellipses`  
`vector<Reg_Polygon*> reg_polygons`  
`vector<Rectangle*> rectangles`  
 Vectors of pointers to the `Paths`, `Circles`, `Ellipses`, `Reg_Polygons`, and `Rectangles`, respectively, belonging to the `Solid`, if any exist.

`valarray<real> projective_extremes` [Protected variable]  
 The maximum and minimum values for the x, y, and z-coordinates of the `Points` belonging to the `Solid`. Used in `Picture::output()` for testing whether a `Solid` is projectable using a particular set of arguments.

`unsigned short CIRCLE` [Public static const variables]  
`unsigned short ELLIPSE`  
`unsigned short PATH`  
`unsigned short RECTANGLE`  
`unsigned short REG_POLYGON`  
 Used as arguments in the functions `get_shape_ptr()` and `get_shape_center()` (see Section 34.8 [Returning Elements and Information], page 249).

## 34.2 Constructors and Setting Functions

`void Solid (void)` [Default constructor]  
Creates an empty `Solid`.

`void Solid (const Solid& s)` [Copy constructor]  
Creates a new `Solid` and makes it a copy of `s`.

`Solid* create_new<Solid> (const Solid* s)` [Template specializations]  
`Solid* create_new<Solid> (const Solid& s)`

Pseudo-constructors for dynamic allocation of `Solids`. They create a `Solid` on the free store and allocate memory for it using `new(Solid)`. They return a pointer to the new `Solid`.

If `s` is a non-zero pointer or a reference, the new `Solid` will be a copy of `s`. If the new object is not meant to be a copy of an existing one, '0' must be passed to `create_new<Solid>()` as its argument. See Chapter 14 [Dynamic Allocation of Shapes], page 83, for more information.

## 34.3 Destructor

`void ~Solid (void)` [virtual Destructor]  
This function currently has an empty definition, but its existence prevents GCC 3.3 from issuing the following warning: “‘class Solid’ has virtual functions but non-virtual destructor”.

## 34.4 Operators

`const Solid& operator= (const Solid& s)` [Virtual function]  
Assignment operator. Makes `*this` a copy of `s`, discarding the old contents of `*this`.

`Transform operator*= (const Transform& t)` [Virtual function]  
Multiplication by a `Transform`. All of the `Shapes` that make up the `Solid` are transformed by `t`.

## 34.5 Copying

`Shape* get_copy (void)` [const virtual function]  
Dynamically allocates a new `Solid` on the free store, using `create_new<Solid>()`, and makes it a copy of `*this`. Then, a pointer to `Shape` is pointed at the copy and returned. Used for putting `Solids` onto `Picture::shapes` in the drawing and filling functions for `Solid`. See Section 34.13 [Solid Reference; Drawing and Filling], page 254.

## 34.6 Setting Members

`bool set_on_free_store ([bool b = true])` [Virtual function]  
 Sets `on_free_store` to `b`. This function is called in the template function `create_new()`. See Section 34.2 [Solid Reference; Constructors and Setting Functions], page 248.

## 34.7 Querying

`bool is_on_free_store (void)` [const virtual function]  
 Returns the value of `on_free_store`; `true`, if the `Solid` was dynamically allocated on the free store, otherwise `false`. `Solids`, and objects of classes derived from `Solid`, should only ever be allocated on the free store by a specialization of the template function `create_new()`. See Section 34.2 [Solid Reference; Constructors and Setting Functions], page 248.

## 34.8 Returning Elements and Information

`const Point& get_center (void)` [const virtual function]  
 Returns `center`. If the `Solid` doesn't have a meaningful center, the return value will probably be `INVALID_POINT`.

### Getting Shape Centers

`const Point& get_shape_center (const unsigned short shape_type, const unsigned short s)` [const virtual function]

Returns the `center` of a `Shape` belonging to the `Solid`. Currently, the object can be a `Circle`, `Ellipse`, `Rectangle`, or `Reg_Polygon`, and it is accessed through a pointer on one of the following vectors of pointers to `Shape`: `circles`, `ellipses`, `rectangles`, or `reg_polygons`. The type of object is specified using the `shape_type` argument. The following public static const data members of `Solid` can (and probably should) be passed as the `shape_type` argument: `CIRCLE`, `ELLIPSE`, `RECTANGLE`, and `REG_POLYGON`.

The argument `s` is used to index the vector.

This function is called within the more specialized functions in this section, namely: `get_circle_center()`, `get_ellipse_center()`, `get_rectangle_center()`, and `get_reg_polygon_center()`. I don't expect it to be needed in user code very often.

```
Dodecahedron d(origin, 3);
d.filldraw();
Point C = d.get_shape_center(Solid::REG_POLYGON, 1);
C.dotlabel("C");
```

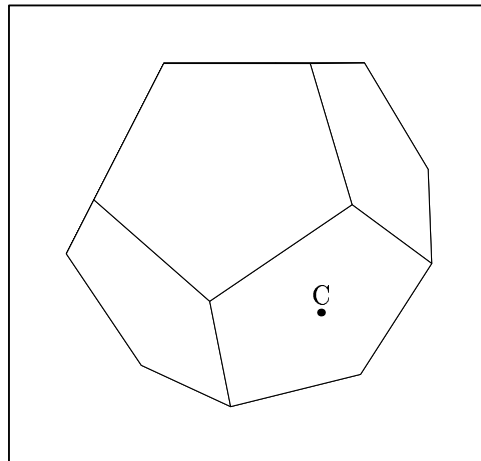

Figure 182.

Note that this function will have to be changed, if new vectors of `Shape` pointers are added to `class Solid`!

```
const Point& get_circle_center (const unsigned short s) [const virtual functions]
const Point& get_ellipse_center (const unsigned short s)
const Point& get_rectangle_center (const unsigned short s)
const Point& get_reg_polygon_center (const unsigned short s)
```

These functions all return the center of the `Shape` pointed to by a pointer on one of the vectors of `Shapes` belonging to the `Solid`. The argument `s` indicates which element on the vector is to be accessed. For example, `get_rectangle_center(2)` returns the center of the `Rectangle` pointed to by `rectangles[2]`.

```
Cuboid c(origin, 3, 4, 5, 0, 30);
c.draw();
for (int i = 0; i < 6; ++i)
    c.get_rectangle_center(i).label(i, "");
```

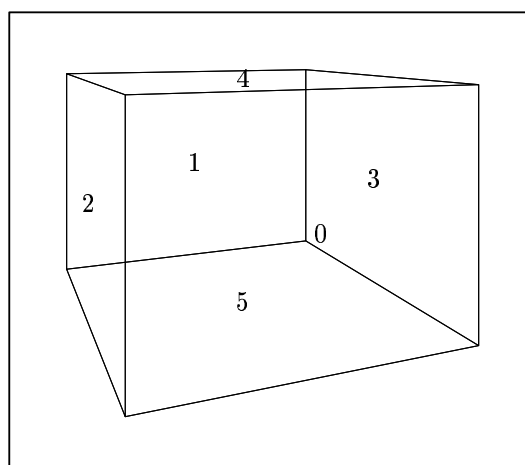

Figure 183.

## Getting Shapes

The functions in this section all return `const` pointers to `Shape`, or one of its derived classes. Therefore, they must be invoked in such a way, that the `const` qualifier is not discarded. See the description of `get_reg_polygon_ptr()` below, for an example.

`Shape* get_shape_ptr (const unsigned short shape_type, const unsigned short s)` [const virtual function]

Copies one of the objects belonging to the `Solid`, and returns a pointer to `Shape` that points to the copy. The object is found by dereferencing one of the pointers on one of the vectors of pointers belonging to the `Solid`. Currently, these vectors are `circles`, `ellipses`, `paths`, `rectangles`, and `reg_polygons`. The argument `shape_type` specifies the vector, and the argument `s` specifies which element of the vector should be accessed. The following public static `const` data members of `Solid` can (and probably should) be passed as the `shape_type` argument: `CIRCLE`, `ELLIPSE`, `PATH`, `RECTANGLE`, and `REG_POLYGON`.

This function was originally intended to be called within the more specialized functions in this section, namely: `get_circle_ptr()`, `get_ellipse_ptr()`, `get_path_ptr()`, `get_rectangle_ptr`, and `get_reg_polygon_ptr`. However, these functions no longer use `get_shape_ptr()`, so this function is probably no longer needed.

```
Icosahedron I(origin, 3);
I.filldraw();
Reg_Polygon* t =
static_cast<Reg_Polygon*>(I.get_shape_ptr(Solid::REG_POLYGON, 9));
t->fill(gray);
```

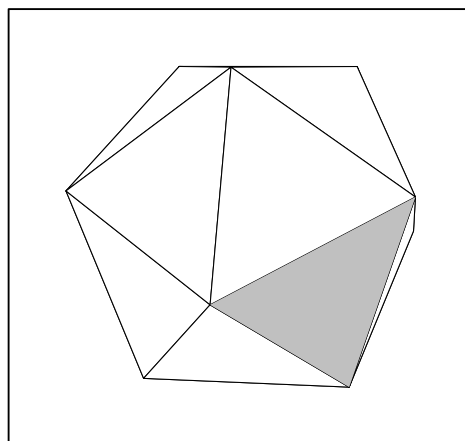

Figure 184.

```

const Reg_Polygon* get_circle_ptr (const unsigned      [const virtual functions]
    short s)
const Reg_Polygon* get_ellipse_ptr (const unsigned short s)
const Reg_Polygon* get_path_ptr (const unsigned short s)
const Reg_Polygon* get_rectangle_ptr (const unsigned short s)
const Reg_Polygon* get_reg_polygon_ptr (const unsigned short s)

```

Each of these functions returns a pointer from one of the vectors of `Shape` pointers belonging to the `Solid`. The argument `s` specifies which element of the appropriate vector should be returned. For example, `get_reg_polygon_ptr(2)` returns the `Reg_Polygon*` in `reg_polygons[2]`.

Since these functions return `const` pointers, they must be invoked in such a way, that the `const` qualifier is not discarded, as noted at the beginning of this section. The following example demonstrates two ways of invoking `get_reg_polygon_ptr()`:

```

Dodecahedron d(origin, 3);
d.draw();
const Reg_Polygon* ptr = d.get_reg_polygon_ptr(0);
ptr->draw(black, "evenly scaled 4", "pencircle scaled 1mm");
Reg_Polygon A = *d.get_reg_polygon_ptr(5);
A.fill(gray);

```

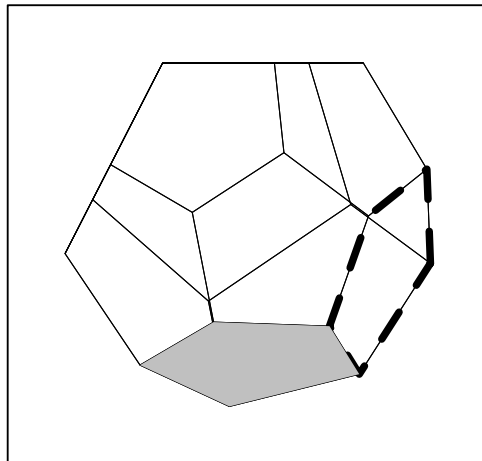

Figure 185.

## 34.9 Showing

```

void show ([string text = "", [char coords = 'w',      [const virtual function]
    [const bool do_persp = true, [const bool do_apply = true, [Focus* f = 0,
    [const unsigned short proj = Projections::PERSP, [const real factor =
    1]]]]]])

```

Prints `text` and the value of `on_free_store` to the standard output (`stdout`), and then calls `show()` on the objects pointed to by the pointers on `paths`, `circles`, `ellipses`, `reg_polygons`, and `rectangles`, unless the vectors are empty. The arguments are passed to `Path::show()`, `Ellipse::show()`, etc. If a vector is empty, a message to this effect is printed to the standard output.



### 34.10 Affine Transformations

Transform **scale** (real *x*, [real *y* = 0, [real *z* = 0]]) [Virtual functions]

Solid. Transform **shear** (real *xy*, [real *xz* = 0, [real *yx* = 0, [real *yz* = 0, [real *zx* = 0, [real *zy* = 0]]]]])

Transform **shift** (real *x*, [real *y* = 0, [real *z* = 0]])

Transform **shift** (const Point& *pt*)

Transform **rotate** (const real *x*, [const real *y* = 0, [const real *z* = 0]])

Transform **rotate** (const Point& *p0*, const Point& *p1*, [const real *angle* = 180])

These functions perform the corresponding transformations on all of the **Shapes** belonging to the **Solid**. See Section 19.10 [Transform Reference; Affine Transformations], page 100.

### 34.11 Applying Transformations

void **apply\_transform** (void) [Virtual function]

Calls `apply_transform()` on all of the **Shapes** belonging to the **Solid**.

### 34.12 Outputting

The functions in this section are called, directly or indirectly, by `Picture::output()`. See Section 21.8 [Picture Reference; Outputting], page 113.

void **output** (void) [Virtual function]

Writes the MetaPost code for drawing, filling, filldrawing, undrawing, unfilling, or unfilldrawing the **Solid** to `out_stream`.

void **suppress\_output** (void) [Virtual function]

Used in `Picture::output()`. Sets `do_output` to `false`, if the **Solid** cannot be projected using a particular set of arguments to `Picture::output()`.

void **unsuppress\_output** (void) [Virtual function]

Used in `Picture::output()`. Resets `do_output` to `true`, so that the **Solid** will be tested for projectability again, if the **Picture** it's on is output again.

vector<Shape\*> **extract** (const Focus& *f*, const unsigned short *proj*, real *factor*) [Virtual function]

Tests whether all of the **Shapes** belonging to the **Solid** are projectable, using the arguments passed to `output()`. If it is, this function returns a vector of pointers to **Shape** containing a single pointer to the **Solid**. If not, an empty vector is returned.

bool **set\_extremes** (void) [Virtual function]

Sets `projective_extremes` to contain the maximum and minimum values for the *x*, *y*, and *z*-coordinates of the **Points** on the **Shape**. Used for determining projectability of a **Solid** using a particular set of arguments.

`const valarray<real> get_extremes (void)` [const inline virtual function]  
Returns `projective_extremes`.

`real get_minimum_z (void)` [const virtual functions]

`real get_maximum_z (void)`

`real get_mean_z (void)`

Returns the minimum, maximum, or mean z-value, respectively, of the `Points` belonging to the `Solid`. Used for surface hiding. See Section 9.3 [Surface Hiding], page 66.

### 34.13 Drawing and Filling

`void draw` ([const vector<const Color\*> *v* = [const virtual function]  
`Colors::default_color_vector`, [const string *ddashed* = "", [const  
string *ppen* = "", [Picture& *picture* = current\_picture]]]])

Draws the `Solid`.

This function allocates a new `Solid`, makes it a copy of `*this`, and puts a pointer to the copy onto `picture.shapes`. The data members of the `Shapes` belonging to the copy are set appropriately, so that they can be drawn, when `Picture::output()` is called.

The `Colors` used for drawing the various `Paths`, `Circles`, `Ellipses`, etc., belonging to the `Solid` are passed in *v*. If the `Solid` contains more `Shapes` than *v* contains pointers to `Color`, the `Color` pointed to by the last pointer on *v* is used to draw the remaining `Shapes`.

Currently, a `Solid` can only be drawn with a single dash pattern (*ddashed*), and pen (*ppen*).

`void fill` ([const vector<const Color\*> *v* = [const virtual function]  
`Colors::default_color_vector`, [Picture& *picture* = current\_picture]])

Fills the `Solid`.

This function allocates a new `Solid` makes it a copy of `*this`, and puts a pointer to it onto `picture.shapes`. The data members of the `Shapes` belonging to the copy are set appropriately, so that they can be filled, when `Picture::output()` is called.

The `Colors` used for filling the various `Paths`, `Circles`, `Ellipses`, etc., belonging to the `Solid` are passed in *v*. If the `Solid` contains more `Shapes` than *v* contains pointers to `Color`, the `Color` pointed to by the last pointer on *v* is used to fill the remaining `Shapes`.

`void filldraw` ([const vector<const Color\*> *draw\_colors* [const virtual function]  
= `Colors::default_color_vector`, [const vector<const Color\*>  
*fill\_colors* = `Colors::background_color_vector`, [const string *ddashed*  
= "", [const string *ppen* = "", [Picture& *picture* = current\_picture]]]])

Filldraws the `Solid`.

This function allocates a new `Solid`, makes it a copy of `*this`, and puts a pointer to it onto `picture.shapes`. The data members of the `Shapes` belonging to the copy are set appropriately, so that they can be filldrawn, when `Picture::output()` is called.

The `Colors` used for drawing and filling the various `Paths`, `Circles`, `Ellipses`, etc., belonging to the `Solid` are passed in `draw_colors` and `fill_colors`. If the `Solid` contains more `Shapes` than `draw_colors` contains pointers to `Color`, the `Color` pointed to by the last pointer on `draw_colors` is used to draw the remaining `Shapes`. The same applies to `fill_colors`.

Currently, a `Solid` can only be filldrawn with a single dash pattern (`ddashed`), and pen (`ppen`).

```
void undraw ([const string ddashed = "", [const [const virtual function]
             string ppen = "", [Picture& picture = current_picture]]])
```

Undraws the `Solid`.

This function allocates a new `Solid`, makes it a copy of `*this`, and puts a pointer to it onto `picture.shapes`. The data members of the `Shapes` belonging to the copy are set appropriately, so that they can be undrawn, when `Picture::output()` is called.

A `Solid` can currently only be undrawn using a single dash pattern (`ddashed`), and pen (`ppen`).

```
void unfill ([Picture& picture = current_picture]) [const virtual function]
```

Unfills the `Solid`.

This function allocates a new `Solid` makes it a copy of `*this`, and puts a pointer to it onto `picture.shapes`. The data members of the `Shapes` belonging to the copy are set appropriately, so that they can be unfilled, when `Picture::output()` is called.

```
void unfilldraw ([const string ddashed = "", [const [const virtual function]
             string ppen = "", [Picture& picture = current_picture]]])
```

```
void undraw ([const string ddashed = "", [const [const virtual function]
             string ppen = "", [Picture& picture = current_picture]]])
```

Unfilldraws the `Solid`.

This function allocates a new `Solid`, makes it a copy of `*this`, and puts a pointer to it onto `picture.shapes`. The data members of the `Shapes` belonging to the copy are set appropriately, so that they can be unfilldrawn, when `Picture::output()` is called.

A `Solid` can currently only be unfilldrawn using a single dash pattern (`ddashed`), and pen (`ppen`).

## 34.14 Clearing

```
void clear (void) [Virtual function]
```

Calls `clear()` on all the `Shapes` belonging to the `Solid`. Used in `Picture::clear()` for deallocating and destroying `Solids`.

Currently, `<Shape>.clear()` always resolves to `Path::clear()`, since none of the other types of `Shape` that a `Solid` can contain, e.g., `Ellipse`, `Circle`, etc., overloads `Path::clear()`.

## 35 Faced Solid Reference

Class `Solid_Faced` is defined in `'solfaceted.web'`. It is derived from `Solid` using public derivation.

`Solid_Faced` currently has no member functions. It is intended for use as a base class. The classes `Cuboid` and `Polyhedron` are derived from `Solid_Faced`. See Chapter 36 [Cuboid Reference], page 257, and Chapter 37 [Polyhedron Reference], page 259.

### 35.1 Data Members

`unsigned short faces` [Protected variable]

The number of faces of the `Solid_Faced`.

`unsigned short vertices` [Protected variable]

The number of vertices of the `Solid_Faced`.

`unsigned short edges` [Protected variable]

The number of edges of the `Solid_Faced`.

## 36 Cuboid Reference

Class `Cuboid` is defined in 'cuboid.web'. It is derived from `Solid_Faced` using public derivation.

### 36.1 Data Members

`real height` [Protected variables]  
`real width`  
`real depth`

The height, width, and depth of the `Cuboid`, respectively.

Please note, that “height”, “width”, and “depth” are conventional terms. There are no restrictions on the orientation of a `Cuboid`.

### 36.2 Constructors and Setting Functions

`void Cuboid (void)` [Default constructor]  
 Creates an empty `Cuboid`.

`void Cuboid (const Cuboid& c)` [Copy constructor]  
 Creates a new `Cuboid` and makes it a copy of `c`.

`void Cuboid (const Point& c, const real h, const real w, const real d, [const real x = 0, [const real y = 0, [const real z = 0]])` [Constructor]  
 Creates a `Cuboid` with center at the origin, with `height`  $\equiv h$ , `width`  $\equiv w$ , and `depth`  $\equiv d$ . If `x`, `y`, or `z` is non-zero, the `Cuboid` is rotated by the amounts indicated around the corresponding main axes. Finally, the `Cuboid` is shifted such that `center` comes to lie at `c`.

```
Point P(-3, -2, 12);
Cuboid c(P, 3, 5, 2.93, 35, 10, 60);
```

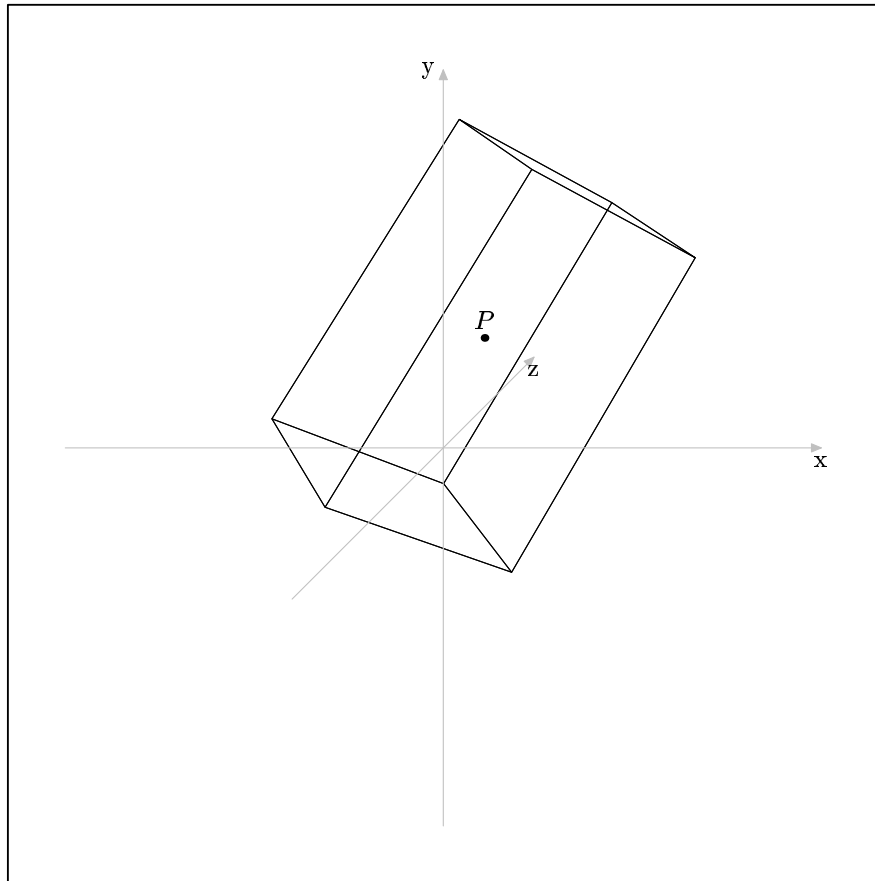

Figure 186.

**Cuboid\* create\_new<Cuboid>** (const Cuboid\* c) [Template specializations]

**Cuboid\* create\_new<Cuboid>** (const Cuboid& c)

Pseudo-constructors for dynamic allocation of **Cuboids**. They create a **Cuboid** on the free store and allocate memory for it using `new(Cuboid)`. They return a pointer to the new **Cuboid**.

If *c* is a non-zero pointer or a reference, the new **Cuboid** will be a copy of *c*. If the new object is not meant to be a copy of an existing one, '0' must be passed to `create_new<Cuboid>()` as its argument. See Chapter 14 [Dynamic Allocation of Shapes], page 83, for more information.

**void ~Cuboid** (void) [Destructor]

Deallocates the **Rectangles** pointed to by the pointers on **rectangles** (a **Solid** data member), and calls `rectangles.clear()`. **Cuboids** consist entirely of **Rectangles**, so nothing must be done to the other vectors.

### 36.3 Operators

**void operator=** (const Cuboid& c) [Assignment operator]

Makes the **Cuboid** a copy of *c*. The old contents of `*this` are deallocated (where necessary) and discarded.

## 37 Polyhedron Reference

Class `Polyhedron` is defined in ‘`polyhed.web`’. It is derived from `Solid_Faced` using public derivation. It is intended for use as a base class for specific types of polyhedra. Currently, the classes `Tetrahedron`, `Dodecahedron`, `Icosahedron`, and `Trunc_Octahedron` (truncated octahedron) are derived from `Polyhedron`.

There is a great deal of work left to do on the polyhedra.

### 37.1 Data Members

`unsigned short number_of_polygon_types` [Protected variable]

The number of different types of polygon making up the faces of a `Polyhedron`. The Platonic polyhedra have only one type of face, while the Archimedean can have more.

`real face_radius` [Protected variable]

The radius of the sphere that touches the centers of the polygonal faces of the polyhedron (*Inkugel*, in German).

`real edge_radius` [Protected variable]

The radius of the sphere that touches the centers of the edges of the polyhedron.

`real vertex_radius` [Protected variable]

The radius of the sphere touching the vertices of the polyhedron (*Umkugel*, in German).

### 37.2 Regular Platonic Polyhedra

3DLDF currently has classes for three of the five regular Platonic polyhedra: `Tetrahedron`, `Dodecahedron`, and `Icosahedron`. There is no need for a special `Cube` class, because cubes can be created using `Cuboid` with equal width, height, and depth arguments (see Chapter 36 [Cuboid Reference], page 257). `Octahedron` is missing at the moment, but I plan to add it soon.

#### 37.2.1 Tetrahedron

Class `Tetrahedron` is defined in ‘`polyhed.web`’. It is derived from `Polyhedron` using public derivation.

##### 37.2.1.1 Data Members

`real dihedral_angle` [Protected static const variable]

The angle in radians between the faces of the `Tetrahedron`, namely  $70^{\circ} 32'$ . Only the Platonic polyhedra have a single dihedral angle, so `dihedral_angle` is not a member of `Polyhedron`. This means that it must be a member of all of the classes representing Platonic polyhedra.

`real triangle_radius` [Protected variable]

The radius of the circle enclosing a triangular face of the `Tetrahedron`.

### 37.2.1.2 Constructors and Setting Functions

`void Tetrahedron (void)` [Default constructor]  
Creates an empty `Tetrahedron`.

`void Tetrahedron (const Point& p, const real diameter_of_triangle, [real angle_x = 0, [real angle_y = 0, [real angle_z = 0]]])` [Constructor]

Creates a `Tetrahedron` with its center at the origin. The faces have enclosing circles of diameter *diameter\_of\_triangle*. If any of *angle\_x*, *angle\_y*, or *angle\_z* is non-zero, the `Tetrahedron` is rotated by the amounts specified around the corresponding axes. Finally, if *p* is not the origin, the `Tetrahedron` is shifted such that `center` comes to lie at *p*.

The center of a `Tetrahedron` is the intersection of the line segments connecting the vertices with the centers of the opposite faces.

```
Tetrahedron t(origin, 3);
t.draw();
```

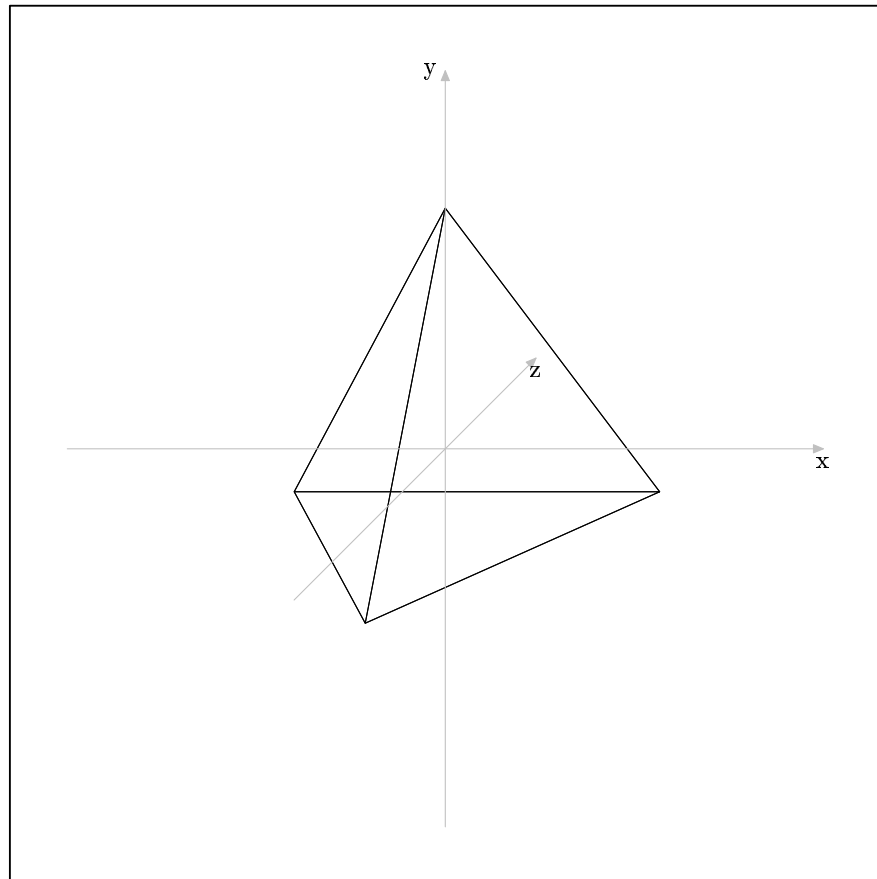

Figure 187.

```
Point P(1, 0, 1);
Tetrahedron t(P, 2.75, 30, 32.5, 20);
t.draw();
```



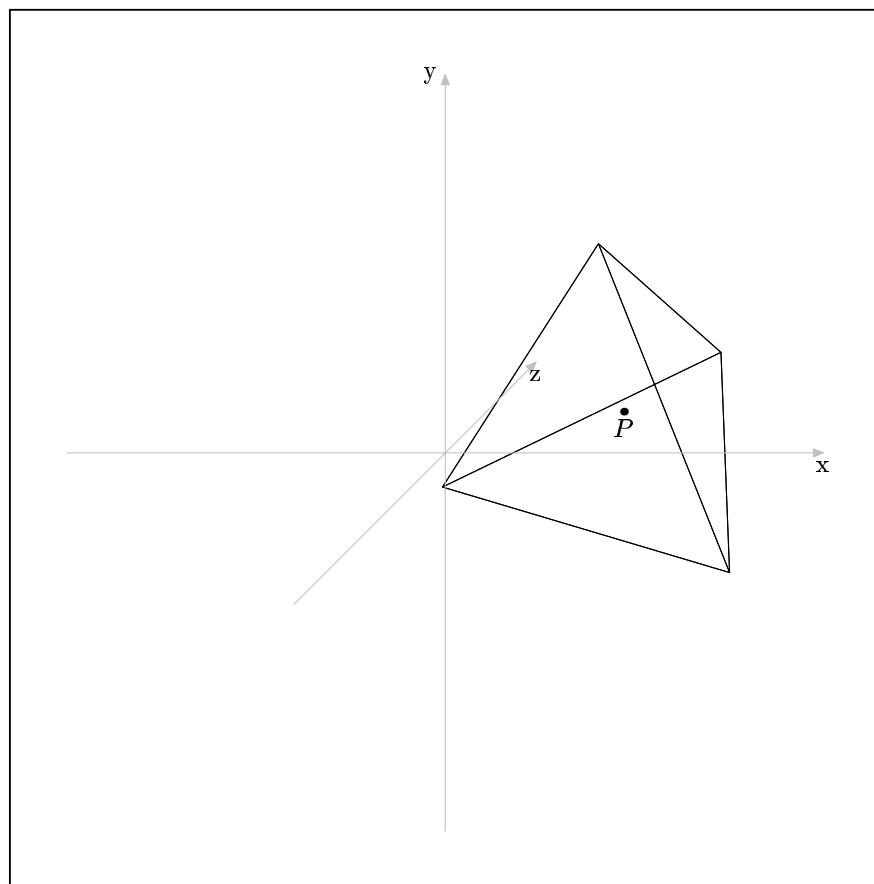

Figure 188.

```
void set (const Point& p, const real diameter_of_triangle, [Setting function]
         [real angle_x = 0, [real angle_y = 0, [real angle_z = 0]]])
    Corresponds to the constructor above.
```

### 37.2.1.3 Net

```
vector<Reg_Polygon*> get_net (const real triangle_diameter) [Static function]
```

Returns the *net* of the Tetrahedron, i.e., the two-dimensional pattern of triangles that can be folded into a model of a tetrahedron.<sup>1</sup> The net lies in the x-z plane. The triangles have enclosing circles of diameter *triangle\_diameter*. The center of the middle triangle is at the origin.

```
vector<Reg_Polygon*> vrp = Tetrahedron::get_net(2);
for (vector<Reg_Polygon*>::iterator iter = vrp.begin();
     iter != vrp.end();
     ++iter)
{
    (**iter).draw();
}
```

<sup>1</sup> Albrecht Dürer invented this method of constructing polyhedra.

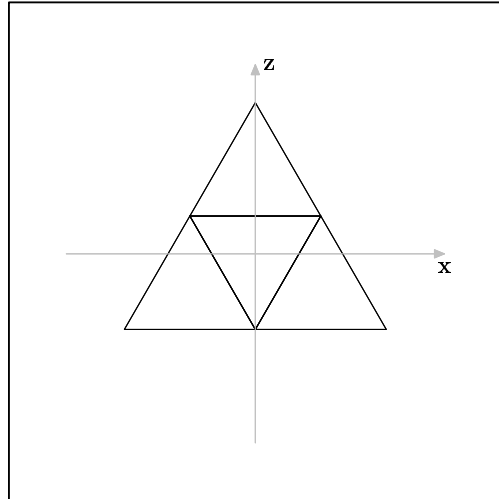

Figure 189.

This function is used in the non-default constructor. See Section 37.2.1.2 [Polyhedron Reference; Regular Platonic Polyhedra; Tetrahedron; Constructors and Setting Functions], page 260. The constructor starts with the net and rotates three of the triangles about the adjacent vertices of the middle triangle. Currently, all of the `Polyhedron` constructors work this way. However, this is not ideal, because rotation uses the sine and cosine functions, which cause inaccuracies to creep in. I think there must be a better way of constructing `Polyhedra`, but I haven't found one yet.

The `Polyhedron` constructors are also especially sensitive to changes made to `Transform::align_with_axis()`. I have already had to rewrite them twice, and since `Transform::align_with_axis()` may need to be changed or rewritten again, it's possible that the `Polyhedron` constructors will have to be, too. It has also occurred in the past, that the `Polyhedra` were constructed correctly on one platform, using a particular compiler, but not on another platform, using a different compiler.

```
void draw_net (const real triangle_diameter, [bool make_tabs = true]) [Static function]
```

Draws the net for a `Tetrahedron` in the x-y plane. The triangles have enclosing circles of diameter *triangle\_diameter*. The origin is used as the center of the middle triangle. The centers of the triangles are numbered. If the argument *make\_tabs* is used, tabs for gluing and/or sewing a cardboard model of the `Tetrahedron` together will be drawn, too. The dots on the tabs mark where to stick the needle through, when sewing the model together (I've had good results with sewing).

```
Tetrahedron::draw_net(3, true);
```

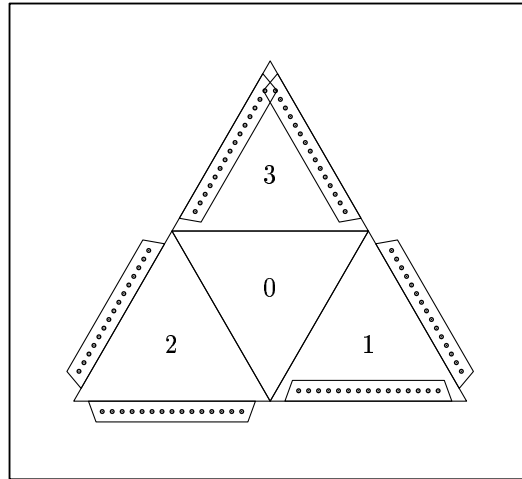

Figure 190.

The net is drawn in the x-y plane, because it currently doesn't work to draw it in the x-z plane. I haven't gotten around to fixing this problem yet.

### 37.2.2 Dodecahedron

Class `Dodecahedron` is defined in `'polyhed.web'`. It is derived from `Polyhedron` using public derivation.

Dodecahedra have 12 regular pentagonal faces.

#### 37.2.2.1 Data Members

`real dihedral_angle` [Protected static const variable]  
The angle between the faces of the `Dodecahedron`, namely  $116^\circ 34' = \pi - \arctan(2)$ .

`real pentagon_radius` [Protected variable]  
The radius of the circle enclosing a pentagonal face of the `Dodecahedron`.

#### 37.2.2.2 Constructors and Setting Functions

`void Dodecahedron (void)` [Default constructor]  
Creates an empty `Dodecahedron`.

`void Dodecahedron (const Point& p, const real pentagon_diameter, [real angle_x = 0, [real angle_y = 0, [real angle_z = 0]])` [Constructor]

Creates a `Dodecahedron` with its center at the origin, where the pentagonal faces have enclosing circles of diameter `pentagon_diameter`. If any of `angle_x`, `angle_y`, or `angle_z` is non-zero, the `Dodecahedron` is rotated by the amounts specified around the corresponding axes. Finally, if `p` is not the origin, the `Dodecahedron` is shifted such that `center` comes to lie at `p`.

```
Point P(-1, -2, 4);
Dodecahedron d(P, 3, 12.5, 16, 2);
d.draw();
```

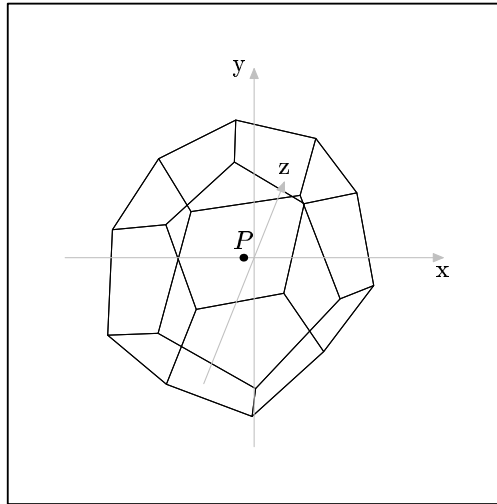

Figure 191.

```
d.filldraw();
```

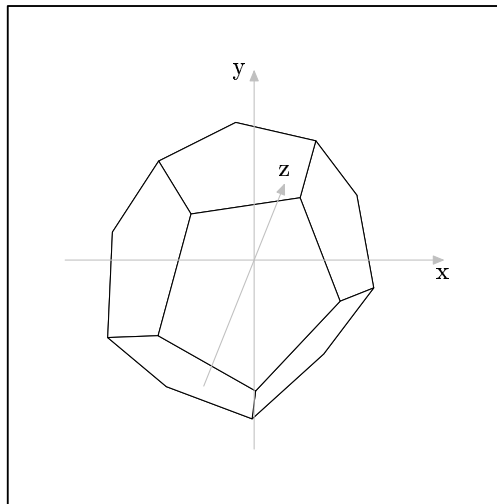

Figure 192.

### 37.2.2.3 Net

```
vector<Reg_Polygon*> get_net (const real [Static function]  
                             pentagon_diameter, [bool do_half = false])
```

Returns the *net*, i.e., the two-dimensional pattern of pentagons that can be folded into a model of a dodecahedron. The net lies in the x-z plane. The pentagons have enclosing circles of diameter *pentagon\_diameter*. The center of the center pentagon of the first half of the net is at the origin. If the argument *do\_half* is **true**, only the first half of the net is created. This is used in the non-default constructor. See Section 37.2.2.2 [Polyhedron Reference; Regular Platonic Polyhedra; Dodecahedron; Constructors and Setting Functions], page 263.

```
vector<Reg_Polygon*> vrp = Dodecahedron::get_net(1);  
for(vector<Reg_Polygon*>::iterator iter = vrp.begin();  
    iter != vrp.end(); ++iter)  
    (**iter).draw();
```

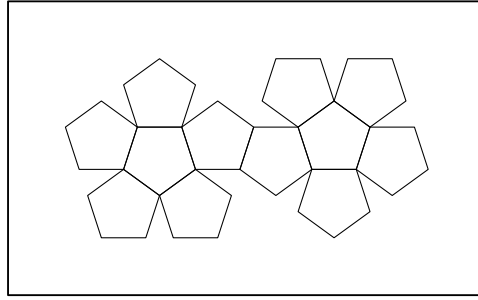

Figure 193.

```
void draw_net (const real pentagon_diameter, [bool portrait    [Static function]
           = true, [bool make_tabs = true]])
```

Draws the net for a Dodecahedron in the x-z plane. The pentagons have enclosing circles of diameter *pentagon\_diameter*. The origin is used as the center of the middle pentagon of the first half of the net. The centers of the pentagons are numbered.

If the argument *portrait* is `true` (the default), the net is arranged for printing in portrait format. If it's `false`, it's arranged for printing in landscape format.

The argument *make\_tabs* currently has no effect. When I get around to programming this, it will be used for specifying whether tabs for gluing and/or sewing a cardboard model should be drawn, too.

```
Dodecahedron::draw_net(1, false);
```

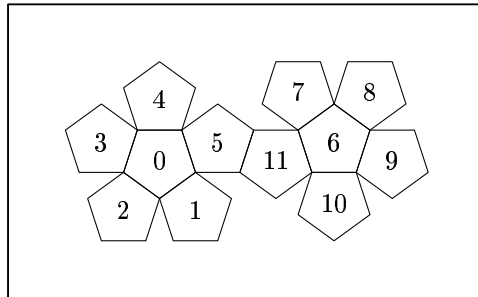

Figure 194.

### 37.2.3 Icosahedron

Class `Icosahedron` is defined in `'polyhed.web'`. It is derived from `Polyhedron` using public derivation.

Icosahedra have 20 regular triangular faces.

#### 37.2.3.1 Data Members

```
real dihedral_angle [Protected static const variable]
```

The angle between the faces of the `Icosahedron`, namely  $138^\circ 11' = \pi - \arcsin(2/3)$ .

```
real triangle_radius [Protected variable]
```

The radius of the circle enclosing a triangular face of the `Icosahedron`.

### 37.2.3.2 Constructors and Setting Functions

`void Icosahedron (void)` [Default constructor]  
Creates an empty Icosahedron.

`void Icosahedron (const Point& p, const real [Constructor]  
diameter_of_triangle, [real angle_x = 0, [real angle_y = 0, [real  
angle_z = 0]]])`

Creates an Icosahedron with its center at the origin, where the triangular faces have enclosing circles of diameter *diameter\_of\_triangle*. If any of *angle\_x*, *angle\_y*, or *angle\_z* is non-zero, the Icosahedron is rotated by the amounts specified around the corresponding axes. Finally, if *p* is not the origin, the Icosahedron is shifted such that *center* comes to lie at *p*.

```
Icosahedron i(origin, 3, 0, 10);
i.draw();
```

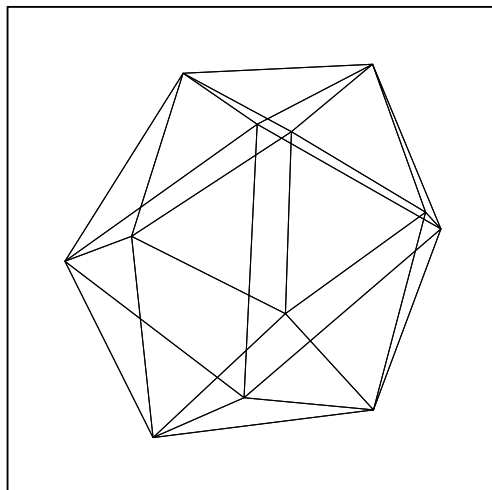

Figure 195.

```
i.filldraw();
```

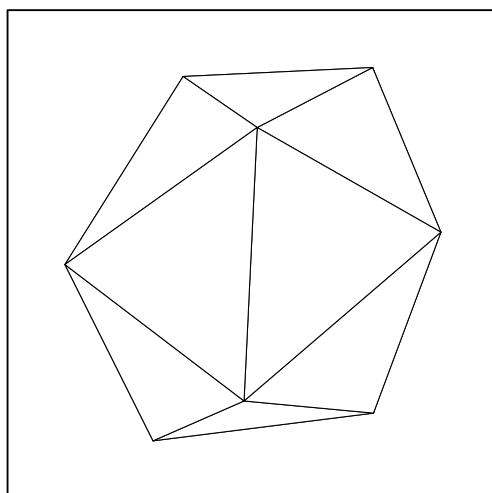

Figure 196.

### 37.2.3.3 Net

`vector<Reg_Polygon*> get_net (const real [Static function]  
     triangle_diameter, [bool do_half = false])`

Returns the *net*, i.e., the two-dimensional pattern of triangles that can be folded into a model of an icosahedron. The net lies in the x-z plane. The triangles have enclosing circles of diameter *triangle\_diameter*. If the argument *do\_half* = `true`, only the first half of the net is created. This is used in the non-default constructor. See Section 37.2.3.2 [Polyhedron Reference; Regular Platonic Polyhedra; Icosahedron; Constructors and Setting Functions], page 266.

```
vector<Reg_Polygon*> vrp = Icosahedron::get_net(1.5);
for (vector<Reg_Polygon*>::iterator iter = vrp.begin();
     iter != vrp.end(); ++iter)
    (**iter).draw();
```

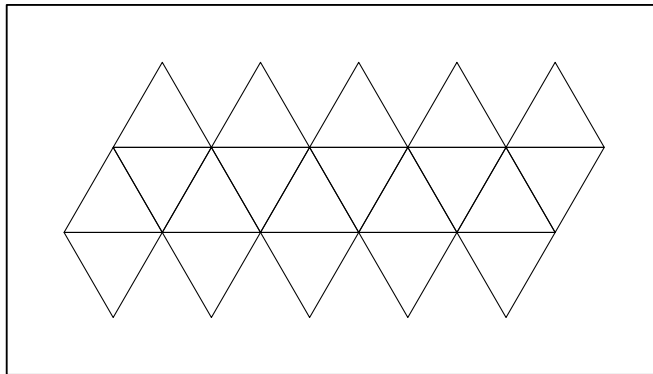

Figure 197.

`void draw_net (const real triangle_diameter, [bool portrait [Static function]  
     = true, [bool make_tabs = true]])`

Draws the net for an `Icosahedron` in the x-z plane. The triangles have enclosing circles of diameter *triangle\_diameter*. If the argument *portrait* is `true` (the default), the net will be arranged for printing in portrait format. If it's `false`, it will be arranged for printing in landscape format. In portrait format, the center of the bottom right triangle is at the origin. In landscape format, the center of the bottom left triangle is at the origin. The triangles are numbered.

The argument *make\_tabs* currently has no effect. When I get around to programming this, it will be used for specifying whether tabs for gluing and/or sewing a cardboard model should be drawn, too.

```
Icosahedron::draw_net(2, false);
```

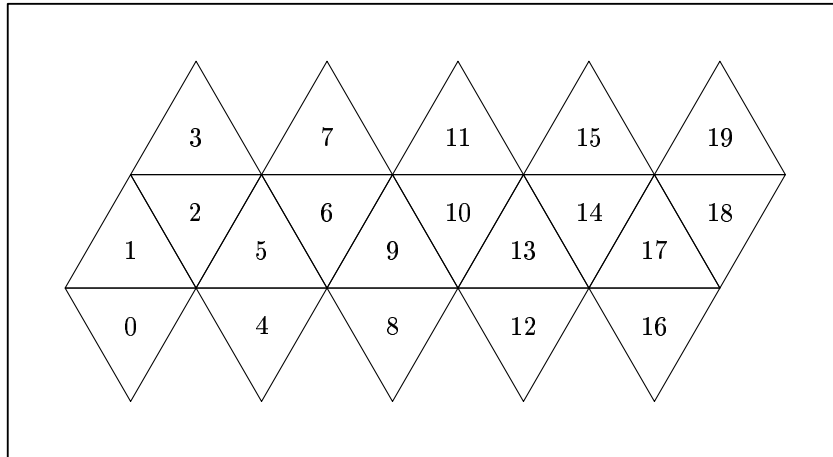

Figure 198.

### 37.3 Semi-Regular Archimedean Polyhedra

Once I've added `class Octahedron`, the only Platonic polyhedron I haven't programmed yet, I plan to start adding classes for the semi-regular Archimedean polyhedra.

#### 37.3.1 Truncated Octahedron

Class `Trunc_Octahedron` is defined in 'polyhed.web'. It is derived from `Polyhedron` using public derivation.

`Trunc_Octahedron` does not yet have a functioning constructor, so it cannot be used as yet.

##### 37.3.1.1 Data Members

`real angle_hex_square` [Protected static const variable]  
 The angle between the hexagonal and the square faces of the truncated octahedron, namely  $125^{\circ} 16'$ .

`real angle_hex_hex` [Protected static const variable]  
 The angle between the hexagonal faces of the truncated octahedron, namely  $109^{\circ} 28'$ .

`real hexagon_radius` [Protected variable]  
 The radius of the circle enclosing a hexagonal or square face of the `Trunc_Octahedron`.

##### 37.3.1.2 Constructors and Setting Functions

`void Trunc_Octahedron (void)` [Default constructor]  
 Creates an empty `Trunc_Octahedron`.

`void Trunc_Octahedron (const Point& p, const real diameter_of_hexagon, [real angle_x = 0, [real angle_y = 0, [real angle_z = 0]]])` [Constructor]

This function does not yet exist! When it does, it will create a `Trunc_Octahedron` with its center at the origin, where the hexagonal and square faces have enclosing



circles of diameter *diameter\_of\_hexagon*. If any of *angle\_x*, *angle\_y*, or *angle\_z* is non-zero, the `Trunc_Octahedron` will be rotated by the amounts specified around the corresponding axes. Finally, if *p* is not the origin, the `Trunc_Octahedron` will be shifted such that `center` comes to lie at *p*.

### 37.3.1.3 Net

```
vector<Reg_Polygon*> get_net (const real [Static function]
    hexagon_diameter, [bool do_half = false])
```

This function does not yet exist! When it does, it will return the *net*, i.e., the two-dimensional pattern of hexagons and squares that can be folded into a model of a truncated octahedron. The net will lie in the x-z plane. The hexagons and squares will have enclosing circles of diameter *hexagon\_diameter*. If the argument *do\_half* is `true`, only the first half of the net will be created. This will be used in the non-default constructor. See Section 37.3.1.2 [Polyhedron Reference; Regular Platonic Polyhedra; Truncated Octahedron Constructors and Setting Functions], page 268.

## 38 Utility Functions

`double trunc (double d)` [Function]

Defined in ‘`pspglb.web`’. For some reason, when I compile 3DLDF using GNU CC on a PC Pentium II XEON under Linux 2.4.4 i686, the standard library function `trunc()` is not available. Therefore, I’ve had to write one. This is a kludge! Someday, I’ll have to try to find a better solution to this problem.

`pair<real, real> solve_quadratic (real a, real b, real c)` [Function]

Defined in ‘`pspglb.web`’. This function tries to find the solutions  $S_0$  and  $S_1$  to the quadratic equation  $ax^2 + bx + c$  according to the formulae  $S_0 \equiv (-b + \sqrt{b^2 - 4ac})/2a$  and  $S_1 \equiv (-b - \sqrt{b^2 - 4ac})/2a$ . Let `r` stand for the return value. If  $S_0$  cannot be found, `r.first` will be `INVALID_REAL`, otherwise  $S_0$ . If  $S_1$  cannot be found, `r.second` will be `INVALID_REAL`, otherwise  $S_1$ .

$$(x + 4)(x + 2) = x^2 + 6x + 8 = 0$$

```
real_pair r = solve_quadratic(1, 6, 8);
```

```
⇒ r.first ≡ -2
```

```
⇒ r.second ≡ -4
```

```
real_pair r = solve_quadratic(1, -2, 4);
```

```
⇒ r.first ≡ INVALID_REAL
```

```
⇒ r.second ≡ INVALID_REAL
```

### 38.1 Perspective Functions

`void persp_0 (const real front_corner_x, const real` [Function]

```
front_corner_z, const real side_lft, const real side_rt, const real
angle_rt, const real f_2_cv, const real gl_2_cv, [const real
horizon_lft = 6, [real horizon_rt = 0, [real gl_lft = 0, [real gl_rt =
0]]]])
```

Defined in ‘`utility.web`’. This function is used for the figure in Section 9.1.2 [The Perspective Projection], page 59, illustrating a perspective projection as it could be done by hand. It draws a rectangle in the ground plane and the construction lines used for putting it into perspective. It also labels the vanishing and measuring points.

The arguments:

```
const real front_corner_x
```

The x-coordinate of the front corner of the rectangle.

```
const real front_corner_z
```

The z-coordinate of the front corner of the rectangle.

```
const real side_lft
```

The length of the left side of the rectangle.

```
const real side_rt
```

The length of the right side of the rectangle.

`const real angle_rt`  
 The angle at which the right side of the rectangle recedes to the horizon.

`const real f_2_cv`  
 The distance from the focus to the center of vision.

`const real gl_2_cv`  
 The distance of the ground line to the center of vision.

`const real horizon_lft`  
 Default: 6. The length of the horizon line leftwards of the center of vision.

`real horizon_rt`  
 Default: 0. The length of the horizon line rightwards of the center of vision.

`real gl_lft`  
 Default: 0. The length of the ground line leftwards of the line from the focus to the center of vision.

`real gl_rt` Default: 0. The length of the ground line rightwards of the line from the focus to the center of vision.

Example:

```
persp_0(3, 2, 10, 5, 47.5, 7, 5, 8.5, 9.5, 8.5, 9.5);
```

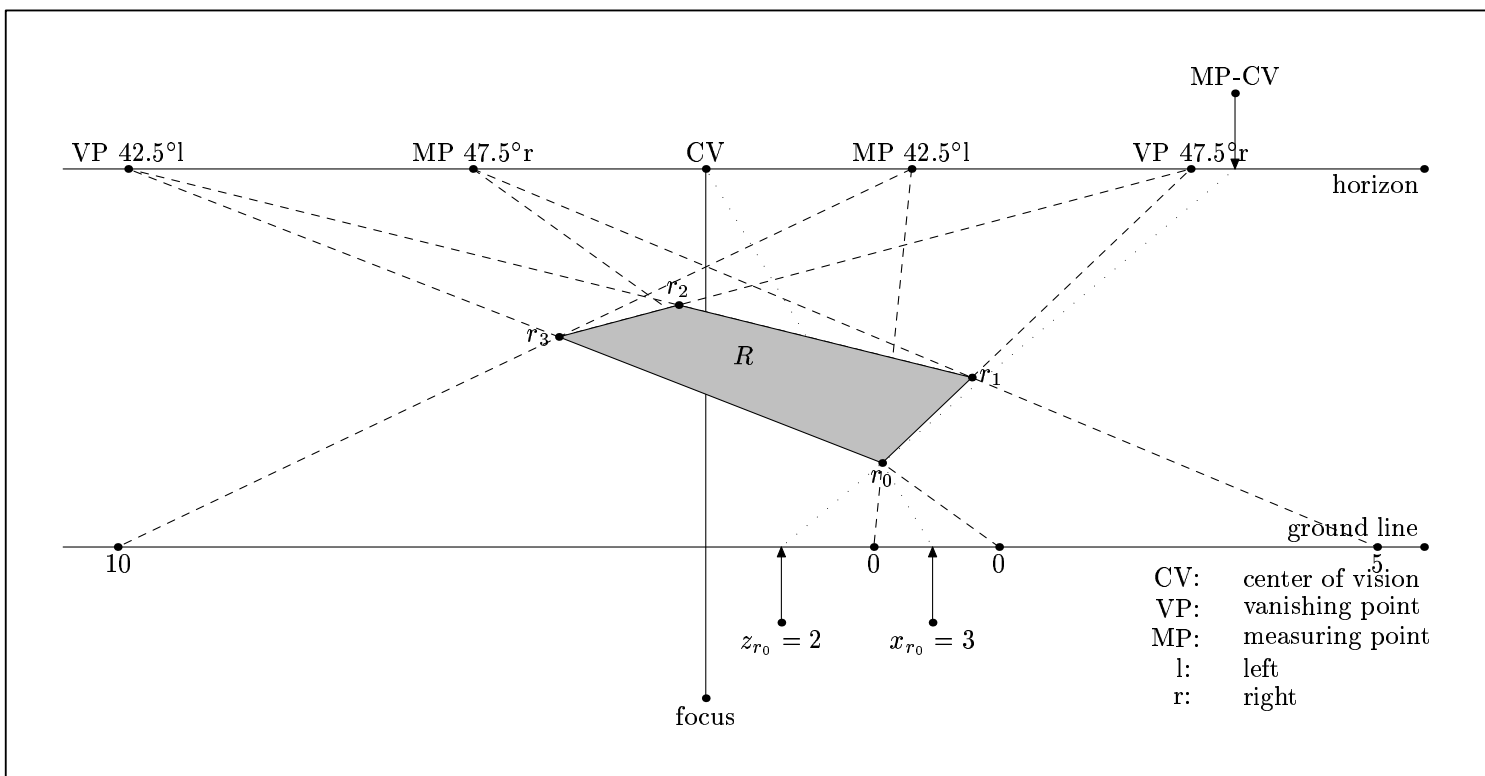

Figure 199.

## 39 Adding a File

Version 1.1.1 was the first version of 3DLDF since it became a GNU package (the current version is 1.1.5.1). In previous versions, recompilation was controlled by an auxiliary program, which I wrote in C++ using CWEB. However, in the course of making 3DLDF conformant to the GNU Coding Standards<sup>1</sup>, this has been changed. Recompilation is now controlled by `make`, as is customary. The chapter “Compiling” in previous editions of this manual, is therefore no longer needed.

Nonetheless, using CWEB still has consequences for the way recompilation must be handled, and it was fairly tricky getting `make` to work for 3DLDF. Users who only put code in ‘`main.web`’ and/or change code in existing files won’t have to worry about this; for others, this chapter explains how to add files to 3DLDF.

Let’s say you want to add a file ‘`widgets.web`’ that defines a `class Widget`, and that the latter needs access to `class Rectangle`, and is in turn required by `class Ellipse`. Code must be added to ‘`3DLDF-1.1.5.1/CWEB/Makefile`’ for ctangling ‘`widgets.web`’, compiling ‘`widgets.cxx`’, and linking ‘`widgets.o`’ with the other object files to make the executable ‘`3dldf`’.

The best way to do this is to change ‘`3DLDF-1.1.5.1/CWEB/Makefile.am`’ and use Automake to generate a new ‘`Makefile.in`’. Then, `configure` can be used to generate a new ‘`Makefile`’. It would be possible to modify ‘`Makefile`’ by hand, but I don’t recommend it. The following assumes that the user has access to Automake. If he or she is using a GNU/Linux system, this is probably true.<sup>2</sup>

‘`widgets.web`’ must be added between ‘`rectangs.web`’ and ‘`ellipses.web`’ in the following variable declaration in ‘`3DLDF-1.1.5.1/CWEB/Makefile.am`’:

```
3dldf_SOME_CWEBS = pspglb.web io.web colors.web transfor.web \
  shapes.web pictures.web points.web \
  lines.web planes.web paths.web curves.web \
  polygons.web rectangs.web ellipses.web \
  circles.web patterns.web solids.web
  solfaced.web cuboid.web polyhed.web \
  utility.web parser.web examples.web
```

Now, add ‘`widgets.o`’ between ‘`ellipses.o`’ and ‘`rectangs.o`’ in the following variable declaration:

```
3dldf_OBS_REVERSED = main.o examples.o parser.o utility.o \
  polyhed.o cuboid.o solfaced.o solids.o \
  patterns.o circles.o ellipses.o rectangs.o \
  polygons.o curves.o paths.o \
  planes.o lines.o points.o pictures.o shapes.o
  transfor.o colors.o io.o pspglb.o
```

`3dldf_OBS_REVERSED` is needed, because 3DLDF fails with a “Segmentation fault”, if the executable is linked using `$(3dldf_OBJECTS)`. This may cause problems, if ‘`3dldf`’ isn’t built using the GNU C++ compiler (GCC).

<sup>1</sup> The GNU Coding Standards are available at [http://www.gnu.org/prep/standards\\_toc.html](http://www.gnu.org/prep/standards_toc.html).

<sup>2</sup> Automake is available for downloading from <http://ftp.gnu.org/gnu/automake/>. The Automake website is at <http://www.gnu.org/software/automake/>.

Now add a target for 'widgets.o' between the targets for 'rectangs.o' and 'ellipses.o', and add 'widgets.tim' after 'rectangs.tim' in the list of prerequisites for 'ellipses.o':

```
rectangs.o: loader.tim pspglb.tim io.tim colors.tim transfor.tim \  
    shapes.tim pictures.tim points.tim lines.tim planes.tim \  
    paths.tim curves.tim polygons.tim rectangs.cxx  
  
ellipses.o: loader.tim pspglb.tim io.tim colors.tim transfor.tim \  
    shapes.tim pictures.tim points.tim lines.tim planes.tim \  
    paths.tim curves.tim polygons.tim rectangs.tim ellipses.cxx
```

This is the result:

```
rectangs.o: loader.tim pspglb.tim io.tim colors.tim transfor.tim \  
    shapes.tim pictures.tim points.tim lines.tim planes.tim \  
    paths.tim curves.tim polygons.tim rectangs.cxx  
  
widgets.o: loader.tim pspglb.tim io.tim colors.tim transfor.tim \  
    shapes.tim pictures.tim points.tim lines.tim planes.tim \  
    paths.tim curves.tim polygons.tim rectangs.tim \  
    widgets.cxx  
  
ellipses.o: loader.tim pspglb.tim io.tim colors.tim transfor.tim \  
    shapes.tim pictures.tim points.tim lines.tim planes.tim \  
    paths.tim curves.tim polygons.tim rectangs.tim widgets.tim \  
    ellipses.cxx
```

In addition, 'widgets.tim' must be added to the list of prerequisites in all of the following targets up to and including 'examples.o'.

## 40 Future Plans

3DLDF is a work-in-progress. In fact, it can never be finished, because the supply of interesting geometric constructions is inexhaustible. However, presently 3DLDF still has a number of major gaps.

If you're interested in contributing to 3DLDF, with respect to one of the topics below and in the following sections, or if you have ideas of your own, see Section 1.7 [Contributing to 3DLDF], page 9.

- Input routine. The lack of one is the most significant defect in 3DLDF, as mentioned in Section 1.5.2 [No Input Routine], page 8.
- Port to other platforms. See Section 1.6 [Ports], page 8.

### 40.1 Geometry

3DLDF currently provides a set of basic plane and solid geometrical figures. However, some important ones are still missing. There are many useful geometrical data types and functions whose implementation would require no more than elementary geometry.

- Add constructors with a normal vector argument rather than angles of rotation about the main axes.
- I have started defining class `Triangle`, which can be used for calculating triangle solutions.
- Add a class `Conic_Section` and derive `Ellipse` from it. This will be the first case of *multiple inheritance*<sup>1</sup> in 3DLDF, since `Ellipse` is already derived from `Path`. See Chapter 31 [Ellipse Reference], page 221. Add the classes `Parabola` and `Hyperbola`.
- Add more functions for finding the intersections of objects of various types, starting with the plane figures. In particular, I believe I've found an algebraic solution for the intersection of an `Ellipse` and a `Circle` in a plane, but I haven't had a chance to try implementing it yet.

If this works, I think it will make it possible to find the intersection of two coplanar ellipses algebraically, because it will be possible to transform them both such that one of them becomes circular.

- Class `Octahedron` will complete the set of regular Platonic polyhedra.
- Add classes for the Kepler-Poinsot polyhedra, the semi-regular Archimedean polyhedra, the dual solids, the stellated Archimedean polyhedra, and the regular compounds.<sup>2</sup>
- Add class `Ellipsoid` and a derived class `Sphere`.
- Improve the specification of `Solid` and `Solid_Faced`. In particular, it would help to store the vertices of `Polyhedra` as individual `Points`, rather than using `Reg_Polygons`. I'd also like to find a better way of generating `Solids`, without using rotations, if possible.

---

<sup>1</sup> Stroustrup, *The C++ Programming Language*, §15.2 "Multiple Inheritance", pp. 390–92.

<sup>2</sup> Cundy and Rollet, *Mathematical Models*, Chapter 3, "Polyhedra", pp. 76–160.

## 40.2 Curves and Surfaces

3D modelling software usually supports the creation and manipulation of various kinds of *spline curves*: *Bézier curves*, *B-splines*, and *non-uniform rational B-splines* or *NURBS*. These curves can be used for generating surfaces.<sup>3</sup>

`paths` in Metafont and MetaPost are Bézier curves. It would be possible to implement three-dimensional Bézier curves in 3DLDF, but unfortunately they are not *projectively invariant*:

Let  $c_0$  represent a Bézier curve in three dimensions,  $P$  the control points of  $c_0$ , and  $t$  a projection transformation. Further, let  $Q$  represent the points generated from applying  $t$  to  $P$ , and  $c_1$  the curve generated from  $Q$ . Finally, let  $R$  represent the points generated from applying  $t$  to all of the points on  $c_0$ , and  $c_2$  the curve through  $R$ :  $c_1 \neq c_2$ .

NURBS, on the other hand, are projectively invariant,<sup>4</sup> so I will probably concentrate on implementing them. On the other hand, it would be nice to be able to implement Metafont's way of specifying `paths` using `'curl'`, `'tension'`, and `'dir'` in 3DLDF. This may prove to be difficult or impossible. I do not yet know whether Metafont's `path` creation algorithm can be generalized to three dimensions.<sup>5</sup>

Curves and surfaces are advanced topics, so it may be a while before I implement them in 3DLDF.

## 40.3 Shadows, Reflections, and Rendering

Shadows and reflections are closely related to transformations and projections. A shadow is the projection of the outline of an object onto a surface or surfaces, and reflection in a plane is an affine transformation.

3D rendering software generally implements shadows, or more generally, *shading*, reflections, and certain other effects using methods involving the calculation of individual pixel values. Surface hiding is also often implemented at the pixel level. 3DLDF does no scan converting ((see Section 1.5.1 [Accuracy], page 7), and hence no calculation of pixel values at all, so these methods cannot be used in 3DLDF at present.

However, it is possible to define functions for generating shadows and reflections within 3DLDF by other means.

I have defined the function `Point::reflect()` for reflecting a `Point` in a `Plane`, and have begun defining versions for other classes.

However, in order for reflections to work, I must define functions for breaking up objects into smaller units. This is also necessary for surface hiding to work properly.

For MetaPost output, I will have to implement shadows, reflections, and surface hiding in this way. However, 3DLDF could be made to produce output in other formats. There are two possibilities: implementing rendering functionality within 3DLDF, or interfacing to

---

<sup>3</sup> Huw Jones, *Computer Graphics through Key Mathematics*, and David Salomon, *Computer Graphics and Geometric Modeling*, are my main sources of information about spline curves.

<sup>4</sup> Jones, Huw. *Computer Graphics through Key Mathematics*, p. 282.

<sup>5</sup> Knuth, Donald Ervin. *The METAFONTbook*, p. 130, and Hobby, John D. *Smooth, Easy to Compute Interpolating Splines*. Discrete and Computational Geometry 1(2).

existing rendering software. If I decide to do the latter, there are again two possibilities: having 3DLDF write output in a format that a renderer can input, or linking to a library supplied by a rendering package.

I haven't yet decided which course to pursue. However, in the long run, I'd like it to be possible to use 3DLDF for fancier graphics than is currently possible using MetaPost and PostScript alone.

## 40.4 Multi-Threading

When 3DLDF is run, there is only one thread of execution. However, it could benefit from the use of multiple threads. In particular, it may be faster and more efficient to have `Picture::output()` run in its own thread. In this case, it will no longer be possible to share `current_picture` among figures.

It may also be worthwhile to execute the code for “figures”, i.e., the code between `'beginfig()'` and `'endfig()'`, inclusive, in their own threads. This will require some changes in the way data are handled. For example, if non-constant objects are shared among figures, there may be no advantage to multi-threading because of the need to coordinate the access of the threads to the objects. If threads are used, then non-constant objects should be declared locally within the figure. They may be locally declared copies of global objects. Alternatively, `beginfig()` could be changed so that objects could be passed to it as arguments, perhaps as a `vector<void*>` and/or a `vector<Shape*>`.



## 41 Changes

Updated 18 July 2007.

### 41.1 3DLDF 1.1.5.1

- Added missing Texinfo files to the `3dldf_TEXINFOS` variable in `'3DLDF-1.1.5.1/DOC/TEXINFO/Makefile'` and reordered the filenames.
- Changed the names of the PNG (Portable Network Graphics) files included in the HTML version of this manual. Changed the names in the commands for including these files in the Texinfo files. I wasn't able to write some of the files with the old names to a CD-R (Compact Disk, Recordable).

### 41.2 3DLDF 1.1.5

In release 1.1.5, I've tied up some loose ends. I wanted to do this before starting on the input routine.

- Added `const real step` argument to the version of `Ellipse::intersection_points()` that takes an `Ellipse` argument. See Section 31.9 [Ellipse Reference; Intersections], page 229.
- It is now possible to “typedef” `real` to either `float` or `double`. This means that `real` can now be made a synonym for either `float` or `double` by using a `typedef` declaration. `real` is typedefged to `float` by default.
- Added `const bool ldf_real_float` and `extern const bool ldf_real_double` for use in non-conditionally compiled code. They are set according to the values of `LDF_REAL_FLOAT` and `LDF_REAL_DOUBLE`.
- `Transform::epsilon()` and `Point::epsilon()` now return different values, depending on the values of the preprocessor macros `LDF_REAL_FLOAT` and `LDF_REAL_DOUBLE`. I have not yet tested whether good values are returned when `real` is `double`.
- `MAX_REAL` and `MAX_REAL_SQRT` are no longer constants. Their values are set at the beginning of `main()`. However, users should not change their values. `MAX_REAL` is the second-largest `float` or `double` on a given machine. This now works for all common architectures.
- Added namespace `System` containing the following functions: `get_endianness()`, `is_big_endian()`, `is_little_endian()`, `get_register_width()`, `is_32_bit()`, `is_64_bit()`, and the template function `get_second_largest()`.  
namespace `System` and its functions are documented in `'system.texi'`, which is new in edition 1.1.5.1.
- Replaced the various `create_new_<type>()` functions with the template function `create_new()`. The latter is documented in `'creatnew.texi'`, which is new in edition 1.1.5.1.
- Added the file `'3DLDF-1.1.5.1/CWEB/cnepspng.el'` to the distribution. It contains the definitions of the Emacs-Lisp functions `convert-eps` and `convert-eps-loop`. See Section 11.2.1.1 [Running 3DLDF; Converting EPS Files; Emacs-Lisp Functions], page 78.

- Added the files ‘3DLDF-1.1.5.1/CWEB/exampman.web’ and ‘3DLDF-1.1.5.1/CWEB/examples.mp’ to the distribution. They contain the C++ and MetaPost code, respectively, for generating the illustrations in this manual.

### 41.3 3DLDF 1.1.4.2

- The illustrations in the HTML output are now scaled to `magstep3`.

### 41.4 3DLDF 1.1.4.1

- The HTML output now includes illustrations.

### 41.5 3DLDF 1.1.4

- `MAX_REAL` is now the second largest float value. However, the calculation is system dependent, and will only work on 32-bit little-endian architectures. I will start working on porting this soon.
- Fixed bug in ‘`tsthweb`’, that caused files to be compiled more often than necessary. It will be necessary to keep an eye on this.
- Added `Rectangle::is_rectangular()`.
- Made `mediate()` a member function of `Point`.
- It is now possible to generate this manual in the Info and HTML formats.

### 41.6 3DLDF 1.1.1

3DLDF 1.1.1 was the first version of 3DLDF since it became a GNU package (the current version is 1.1.5.1). It is now conformant to the GNU Coding Standards, except that a functioning ‘`3DLDF.info`’ cannot be generated from ‘`3DLDF.texi`’. The distribution now includes a `configure` script, ‘`Makefile.in`’ files, and other files generated by Autoconf and Automake. Recompilation is now handled by `make` rather than the auxilliary program `3DLDFcpl`. The files ‘`3DLDFcpl.web`’ and ‘`3DLDFprc.web`’ have been removed from the distribution.

The extension of the C++ files generated by `ctangle` is changed from ‘`c`’ to ‘`cxx`’ before they are compiled. After `ctangle` is run on a CWEB file, ‘`<filename>.c`’ is compared to the old ‘`<filename>.cxx`’ using `diff`. Whitespace, comments, and `#line` preprocessor commands are ignored. The ‘`<filename>.c`’ is only renamed to ‘`<filename>.cxx`’ and compiled if they differ. This way, changes to the  $\text{T}_{\text{E}}\text{X}$  text only in a CWEB file no longer cause recompilation and relinking.

The main Texinfo file is now called ‘`3DLDF.texi`’. It was formerly called ‘`3DLDFman.texi`’. This is because Automake expects this name. For this reason, the CWEB file passed as an argument to `cweave` has been renamed ‘`3DLDFprg.web`’. It was formerly called ‘`3DLDF.web`’.

## Bibliography

Cundy, H. Martyn and A.P. Rollet. *Mathematical Models*. Oxford 1961. Oxford University Press.

Unfortunately out of print.

Finston, Laurence D. *3DLDF: The Program*. Göttingen 2003.

Fischer, Gerd. *Ebene algebraische Kurven*. Vieweg Studium. Aufbaukurs Mathematik. Friedr. Vieweg & Sohn Verlagsgesellschaft mbH. Braunschweig/Wiesbaden 1994.

Gill, Robert W. *Creative Perspective*. London 1975. Thames and Hudson Ltd. ISBN 0-500-27056-2.

Harbison, Samuel P., and Guy L. Steele Jr. *C, A Reference Manual*. Prentice Hall. Englewood Cliffs, New Jersey 1995. ISBN 0-13-326232-4 –Case”. ISBN 0-13-326224-3 –Paperback”.

Hobby, John D. *Smooth, Easy to Compute Interpolating Splines*. Discrete and Computational Geometry 1(2). Springer-Verlag. New York 1986.

Hobby, John D. *A User's Manual for MetaPost*. AT & T Bell Laboratories. Murray Hill, NJ. No date.

Jones, Huw. *Computer Graphics through Key Mathematics*. Springer-Verlag London Limited 2001. ISBN 1-85233-422-3.

Knuth, Donald Ervin. *Metafont: The Program*. Computers and Typesetting; D. Addison Wesley Publishing Company, Inc. Reading, Massachusetts 1986. ISBN 0-201-13438-1.

Knuth, Donald Ervin. *The METAFONTbook*. Computers and Typesetting; C. Addison Wesley Publishing Company, Inc. Reading, Massachusetts 1986.

Knuth, Donald Ervin. *TEX: The Program*. Computers and Typesetting; B. Addison Wesley Publishing Company, Inc. Reading, Massachusetts 1986. ISBN 0-201-13437-3.

Knuth, Donald E. *The TEXbook*. Computers and Typesetting; A. Addison Wesley Publishing Company, Inc. Reading, Massachusetts 1986.

Knuth, Donald E. and Silvio Levy. *The CWEB System of Structured Documentation*. Version 3.64—February 2002.

Rokicki, Tomas. *Dvips: A DVI-to-PostScript Translator* for version 5.66a. February 1997. <http://dante.ctan.org/CTAN/dviware/dvips/>

Salomon, David. *Computer Graphics and Geometric Modeling*. Berlin 1999. Springer-Verlag. ISBN: 0-387-98682-0.

Stallman, Richard M. and Roland McGrath. *GNU Make. A Program for Directing Recompilation*. **make** Version 3.79. Boston 2000. Free Software Foundation, Inc. ISBN: 1-882114-80-9.

Stallman, Richard M. *Using and Porting the GNU Compiler Collection*. For GCC Version 3.3.2. Boston 2003. Free Software Foundation, Inc.

Stroustrup, Bjarne. *The C++ Programming Language*. Special Edition. Reading, Massachusetts 2000. Addison-Wesley. ISBN 0-201-70073-5.

Stroustrup, Bjarne. *The Design and Evolution of C++*. Reading, Massachusetts 1994. Addison-Wesley Publishing Company. ISBN 0-201-54330-3.

Vredeman de Vries, Jan. *Perspective*. New York 1968. Dover Publications, Inc. Standard Book Number: 486-21086-4.

The beautiful perspective constructions in this volume are taken from the original work, first published by Henricus Hondius in Leiden in 1604 and 1605.

White, Gwen. *Perspective. A Guide for Artists, Architects and Designers*. London 1968 and 1982. B T Batsford Ltd. ISBN 0-7134-3412-0.

# Appendix A GNU Free Documentation License

Version 1.2, November 2002

Copyright © 2000,2001,2002 Free Software Foundation, Inc.  
51 Franklin St, Fifth Floor, Boston, MA 02110-1301 USA

Everyone is permitted to copy and distribute verbatim copies of this license document, but changing it is not allowed.

## 0. PREAMBLE

The purpose of this License is to make a manual, textbook, or other functional and useful document *free* in the sense of freedom: to assure everyone the effective freedom to copy and redistribute it, with or without modifying it, either commercially or non-commercially. Secondly, this License preserves for the author and publisher a way to get credit for their work, while not being considered responsible for modifications made by others.

This License is a kind of “copyleft”, which means that derivative works of the document must themselves be free in the same sense. It complements the GNU General Public License, which is a copyleft license designed for free software.

We have designed this License in order to use it for manuals for free software, because free software needs free documentation: a free program should come with manuals providing the same freedoms that the software does. But this License is not limited to software manuals; it can be used for any textual work, regardless of subject matter or whether it is published as a printed book. We recommend this License principally for works whose purpose is instruction or reference.

## 1. APPLICABILITY AND DEFINITIONS

This License applies to any manual or other work, in any medium, that contains a notice placed by the copyright holder saying it can be distributed under the terms of this License. Such a notice grants a world-wide, royalty-free license, unlimited in duration, to use that work under the conditions stated herein. The “Document”, below, refers to any such manual or work. Any member of the public is a licensee, and is addressed as “you”. You accept the license if you copy, modify or distribute the work in a way requiring permission under copyright law.

A “Modified Version” of the Document means any work containing the Document or a portion of it, either copied verbatim, or with modifications and/or translated into another language.

A “Secondary Section” is a named appendix or a front-matter section of the Document that deals exclusively with the relationship of the publishers or authors of the Document to the Document’s overall subject (or to related matters) and contains nothing that could fall directly within that overall subject. (Thus, if the Document is in part a textbook of mathematics, a Secondary Section may not explain any mathematics.) The relationship could be a matter of historical connection with the subject or with related matters, or of legal, commercial, philosophical, ethical or political position regarding them.

The “Invariant Sections” are certain Secondary Sections whose titles are designated, as being those of Invariant Sections, in the notice that says that the Document is released

under this License. If a section does not fit the above definition of Secondary then it is not allowed to be designated as Invariant. The Document may contain zero Invariant Sections. If the Document does not identify any Invariant Sections then there are none. The “Cover Texts” are certain short passages of text that are listed, as Front-Cover Texts or Back-Cover Texts, in the notice that says that the Document is released under this License. A Front-Cover Text may be at most 5 words, and a Back-Cover Text may be at most 25 words.

A “Transparent” copy of the Document means a machine-readable copy, represented in a format whose specification is available to the general public, that is suitable for revising the document straightforwardly with generic text editors or (for images composed of pixels) generic paint programs or (for drawings) some widely available drawing editor, and that is suitable for input to text formatters or for automatic translation to a variety of formats suitable for input to text formatters. A copy made in an otherwise Transparent file format whose markup, or absence of markup, has been arranged to thwart or discourage subsequent modification by readers is not Transparent. An image format is not Transparent if used for any substantial amount of text. A copy that is not “Transparent” is called “Opaque”.

Examples of suitable formats for Transparent copies include plain ASCII without markup, Texinfo input format, LaTeX input format, SGML or XML using a publicly available DTD, and standard-conforming simple HTML, PostScript or PDF designed for human modification. Examples of transparent image formats include PNG, XCF and JPG. Opaque formats include proprietary formats that can be read and edited only by proprietary word processors, SGML or XML for which the DTD and/or processing tools are not generally available, and the machine-generated HTML, PostScript or PDF produced by some word processors for output purposes only.

The “Title Page” means, for a printed book, the title page itself, plus such following pages as are needed to hold, legibly, the material this License requires to appear in the title page. For works in formats which do not have any title page as such, “Title Page” means the text near the most prominent appearance of the work’s title, preceding the beginning of the body of the text.

A section “Entitled XYZ” means a named subunit of the Document whose title either is precisely XYZ or contains XYZ in parentheses following text that translates XYZ in another language. (Here XYZ stands for a specific section name mentioned below, such as “Acknowledgements”, “Dedications”, “Endorsements”, or “History”.) To “Preserve the Title” of such a section when you modify the Document means that it remains a section “Entitled XYZ” according to this definition.

The Document may include Warranty Disclaimers next to the notice which states that this License applies to the Document. These Warranty Disclaimers are considered to be included by reference in this License, but only as regards disclaiming warranties: any other implication that these Warranty Disclaimers may have is void and has no effect on the meaning of this License.

## 2. VERBATIM COPYING

You may copy and distribute the Document in any medium, either commercially or noncommercially, provided that this License, the copyright notices, and the license notice saying this License applies to the Document are reproduced in all copies, and

that you add no other conditions whatsoever to those of this License. You may not use technical measures to obstruct or control the reading or further copying of the copies you make or distribute. However, you may accept compensation in exchange for copies. If you distribute a large enough number of copies you must also follow the conditions in section 3.

You may also lend copies, under the same conditions stated above, and you may publicly display copies.

### 3. COPYING IN QUANTITY

If you publish printed copies (or copies in media that commonly have printed covers) of the Document, numbering more than 100, and the Document's license notice requires Cover Texts, you must enclose the copies in covers that carry, clearly and legibly, all these Cover Texts: Front-Cover Texts on the front cover, and Back-Cover Texts on the back cover. Both covers must also clearly and legibly identify you as the publisher of these copies. The front cover must present the full title with all words of the title equally prominent and visible. You may add other material on the covers in addition. Copying with changes limited to the covers, as long as they preserve the title of the Document and satisfy these conditions, can be treated as verbatim copying in other respects.

If the required texts for either cover are too voluminous to fit legibly, you should put the first ones listed (as many as fit reasonably) on the actual cover, and continue the rest onto adjacent pages.

If you publish or distribute Opaque copies of the Document numbering more than 100, you must either include a machine-readable Transparent copy along with each Opaque copy, or state in or with each Opaque copy a computer-network location from which the general network-using public has access to download using public-standard network protocols a complete Transparent copy of the Document, free of added material. If you use the latter option, you must take reasonably prudent steps, when you begin distribution of Opaque copies in quantity, to ensure that this Transparent copy will remain thus accessible at the stated location until at least one year after the last time you distribute an Opaque copy (directly or through your agents or retailers) of that edition to the public.

It is requested, but not required, that you contact the authors of the Document well before redistributing any large number of copies, to give them a chance to provide you with an updated version of the Document.

### 4. MODIFICATIONS

You may copy and distribute a Modified Version of the Document under the conditions of sections 2 and 3 above, provided that you release the Modified Version under precisely this License, with the Modified Version filling the role of the Document, thus licensing distribution and modification of the Modified Version to whoever possesses a copy of it. In addition, you must do these things in the Modified Version:

- A. Use in the Title Page (and on the covers, if any) a title distinct from that of the Document, and from those of previous versions (which should, if there were any, be listed in the History section of the Document). You may use the same title as a previous version if the original publisher of that version gives permission.

- B. List on the Title Page, as authors, one or more persons or entities responsible for authorship of the modifications in the Modified Version, together with at least five of the principal authors of the Document (all of its principal authors, if it has fewer than five), unless they release you from this requirement.
- C. State on the Title page the name of the publisher of the Modified Version, as the publisher.
- D. Preserve all the copyright notices of the Document.
- E. Add an appropriate copyright notice for your modifications adjacent to the other copyright notices.
- F. Include, immediately after the copyright notices, a license notice giving the public permission to use the Modified Version under the terms of this License, in the form shown in the Addendum below.
- G. Preserve in that license notice the full lists of Invariant Sections and required Cover Texts given in the Document's license notice.
- H. Include an unaltered copy of this License.
- I. Preserve the section Entitled "History", Preserve its Title, and add to it an item stating at least the title, year, new authors, and publisher of the Modified Version as given on the Title Page. If there is no section Entitled "History" in the Document, create one stating the title, year, authors, and publisher of the Document as given on its Title Page, then add an item describing the Modified Version as stated in the previous sentence.
- J. Preserve the network location, if any, given in the Document for public access to a Transparent copy of the Document, and likewise the network locations given in the Document for previous versions it was based on. These may be placed in the "History" section. You may omit a network location for a work that was published at least four years before the Document itself, or if the original publisher of the version it refers to gives permission.
- K. For any section Entitled "Acknowledgements" or "Dedications", Preserve the Title of the section, and preserve in the section all the substance and tone of each of the contributor acknowledgements and/or dedications given therein.
- L. Preserve all the Invariant Sections of the Document, unaltered in their text and in their titles. Section numbers or the equivalent are not considered part of the section titles.
- M. Delete any section Entitled "Endorsements". Such a section may not be included in the Modified Version.
- N. Do not retitle any existing section to be Entitled "Endorsements" or to conflict in title with any Invariant Section.
- O. Preserve any Warranty Disclaimers.

If the Modified Version includes new front-matter sections or appendices that qualify as Secondary Sections and contain no material copied from the Document, you may at your option designate some or all of these sections as invariant. To do this, add their titles to the list of Invariant Sections in the Modified Version's license notice. These titles must be distinct from any other section titles.



You may add a section Entitled “Endorsements”, provided it contains nothing but endorsements of your Modified Version by various parties—for example, statements of peer review or that the text has been approved by an organization as the authoritative definition of a standard.

You may add a passage of up to five words as a Front-Cover Text, and a passage of up to 25 words as a Back-Cover Text, to the end of the list of Cover Texts in the Modified Version. Only one passage of Front-Cover Text and one of Back-Cover Text may be added by (or through arrangements made by) any one entity. If the Document already includes a cover text for the same cover, previously added by you or by arrangement made by the same entity you are acting on behalf of, you may not add another; but you may replace the old one, on explicit permission from the previous publisher that added the old one.

The author(s) and publisher(s) of the Document do not by this License give permission to use their names for publicity for or to assert or imply endorsement of any Modified Version.

## 5. COMBINING DOCUMENTS

You may combine the Document with other documents released under this License, under the terms defined in section 4 above for modified versions, provided that you include in the combination all of the Invariant Sections of all of the original documents, unmodified, and list them all as Invariant Sections of your combined work in its license notice, and that you preserve all their Warranty Disclaimers.

The combined work need only contain one copy of this License, and multiple identical Invariant Sections may be replaced with a single copy. If there are multiple Invariant Sections with the same name but different contents, make the title of each such section unique by adding at the end of it, in parentheses, the name of the original author or publisher of that section if known, or else a unique number. Make the same adjustment to the section titles in the list of Invariant Sections in the license notice of the combined work.

In the combination, you must combine any sections Entitled “History” in the various original documents, forming one section Entitled “History”; likewise combine any sections Entitled “Acknowledgements”, and any sections Entitled “Dedications”. You must delete all sections Entitled “Endorsements.”

## 6. COLLECTIONS OF DOCUMENTS

You may make a collection consisting of the Document and other documents released under this License, and replace the individual copies of this License in the various documents with a single copy that is included in the collection, provided that you follow the rules of this License for verbatim copying of each of the documents in all other respects.

You may extract a single document from such a collection, and distribute it individually under this License, provided you insert a copy of this License into the extracted document, and follow this License in all other respects regarding verbatim copying of that document.

## 7. AGGREGATION WITH INDEPENDENT WORKS

A compilation of the Document or its derivatives with other separate and independent documents or works, in or on a volume of a storage or distribution medium, is called

an “aggregate” if the copyright resulting from the compilation is not used to limit the legal rights of the compilation’s users beyond what the individual works permit. When the Document is included in an aggregate, this License does not apply to the other works in the aggregate which are not themselves derivative works of the Document.

If the Cover Text requirement of section 3 is applicable to these copies of the Document, then if the Document is less than one half of the entire aggregate, the Document’s Cover Texts may be placed on covers that bracket the Document within the aggregate, or the electronic equivalent of covers if the Document is in electronic form. Otherwise they must appear on printed covers that bracket the whole aggregate.

## 8. TRANSLATION

Translation is considered a kind of modification, so you may distribute translations of the Document under the terms of section 4. Replacing Invariant Sections with translations requires special permission from their copyright holders, but you may include translations of some or all Invariant Sections in addition to the original versions of these Invariant Sections. You may include a translation of this License, and all the license notices in the Document, and any Warranty Disclaimers, provided that you also include the original English version of this License and the original versions of those notices and disclaimers. In case of a disagreement between the translation and the original version of this License or a notice or disclaimer, the original version will prevail.

If a section in the Document is Entitled “Acknowledgements”, “Dedications”, or “History”, the requirement (section 4) to Preserve its Title (section 1) will typically require changing the actual title.

## 9. TERMINATION

You may not copy, modify, sublicense, or distribute the Document except as expressly provided for under this License. Any other attempt to copy, modify, sublicense or distribute the Document is void, and will automatically terminate your rights under this License. However, parties who have received copies, or rights, from you under this License will not have their licenses terminated so long as such parties remain in full compliance.

## 10. FUTURE REVISIONS OF THIS LICENSE

The Free Software Foundation may publish new, revised versions of the GNU Free Documentation License from time to time. Such new versions will be similar in spirit to the present version, but may differ in detail to address new problems or concerns. See <http://www.gnu.org/copyleft/>.

Each version of the License is given a distinguishing version number. If the Document specifies that a particular numbered version of this License “or any later version” applies to it, you have the option of following the terms and conditions either of that specified version or of any later version that has been published (not as a draft) by the Free Software Foundation. If the Document does not specify a version number of this License, you may choose any version ever published (not as a draft) by the Free Software Foundation.

### A.0.1 ADDENDUM: How to use this License for your documents

To use this License in a document you have written, include a copy of the License in the document and put the following copyright and license notices just after the title page:

```
Copyright (C) year your name.  
Permission is granted to copy, distribute and/or modify this document  
under the terms of the GNU Free Documentation License, Version 1.2  
or any later version published by the Free Software Foundation;  
with no Invariant Sections, no Front-Cover Texts, and no Back-Cover  
Texts. A copy of the license is included in the section entitled  
‘‘GNU Free Documentation License’’.
```

If you have Invariant Sections, Front-Cover Texts and Back-Cover Texts, replace the “with...Texts.” line with this:

```
with the Invariant Sections being list their titles, with  
the Front-Cover Texts being list, and with the Back-Cover Texts  
being list.
```

If you have Invariant Sections without Cover Texts, or some other combination of the three, merge those two alternatives to suit the situation.

If your document contains nontrivial examples of program code, we recommend releasing these examples in parallel under your choice of free software license, such as the GNU General Public License, to permit their use in free software.

## Data Type and Variable Index

### A

|                  |          |
|------------------|----------|
| angle            | 150      |
| angle_hex_hex    | 268      |
| angle_hex_square | 268      |
| arrow            | 165      |
| axis             | 150      |
| axis_h           | 210, 221 |
| axis_v           | 210, 221 |
| AXON             | 113      |

### B

|                         |     |
|-------------------------|-----|
| background_color        | 90  |
| background_color_vector | 90  |
| black                   | 90  |
| blue                    | 90  |
| blue_part               | 87  |
| blue_violet             | 90  |
| bool_pair               | 80  |
| bool_point              | 120 |
| bool_point_pair         | 120 |
| bool_point_quadruple    | 120 |
| bool_real               | 80  |
| bool_real_point         | 121 |

### C

|              |               |
|--------------|---------------|
| center       | 198, 215, 247 |
| Circle       | 35, 237       |
| CIRCLE       | 247           |
| circles      | 247           |
| Color        | 87            |
| connectors   | 166           |
| Cuboid       | 46, 257       |
| CURR_Y       | 119           |
| CURR_Z       | 119           |
| cyan         | 90            |
| cycle_switch | 165           |

### D

|                          |               |
|--------------------------|---------------|
| dashed                   | 165           |
| default_background       | 90            |
| default_color            | 90            |
| default_color_vector     | 90            |
| default_focus            | 151           |
| DEFAULT_NUMBER_OF_POINTS | 221           |
| depth                    | 257           |
| dihedral_angle           | 259, 263, 265 |
| direction                | 150, 153      |
| distance                 | 150, 156      |
| do_help_lines            | 166           |
| do_labels                | 110           |
| DO_LABELS                | 108           |

|               |               |
|---------------|---------------|
| do_output     | 119, 165, 247 |
| Dodecahedron  | 48, 263       |
| dot           | 107           |
| DRAW          | 92            |
| draw_color    | 165           |
| DRAWDOT       | 92            |
| drawdot_color | 119           |
| drawdot_value | 119           |

### E

|             |         |
|-------------|---------|
| edge_radius | 259     |
| edges       | 256     |
| Ellipse     | 35, 221 |
| ELLIPSE     | 247     |
| ellipses    | 247     |

### F

|                 |     |
|-----------------|-----|
| face_radius     | 259 |
| faces           | 256 |
| FILL            | 92  |
| fill_color      | 165 |
| fill_draw_value | 165 |
| FILLDRAW        | 92  |
| focus           | 62  |
| Focus           | 150 |
| focus0          | 221 |
| focus1          | 221 |

### G

|              |    |
|--------------|----|
| gray         | 90 |
| green        | 90 |
| green_part   | 87 |
| green_yellow | 90 |

### H

|                   |         |
|-------------------|---------|
| height            | 257     |
| help_color        | 90, 166 |
| help_color_vector | 90      |
| help_dash_pattern | 166     |
| hexagon_radius    | 268     |

### I

|                              |         |
|------------------------------|---------|
| Icosahedron                  | 50, 265 |
| IDENTITY_TRANSFORM           | 95      |
| in_stream                    | 91      |
| internal_angle               | 204     |
| INVALID_BOOL_POINT           | 121     |
| INVALID_BOOL_POINT_PAIR      | 121     |
| INVALID_BOOL_POINT_QUADRUPLE | 121     |

|                               |     |
|-------------------------------|-----|
| INVALID_BOOL_REAL_POINT ..... | 121 |
| INVALID_LINE .....            | 153 |
| INVALID_PLANE .....           | 156 |
| INVALID_POINT .....           | 121 |
| INVALID_REAL .....            | 81  |
| INVALID_REAL_PAIR .....       | 81  |
| INVALID_REAL_SHORT .....      | 81  |
| INVALID_TRANSFORM .....       | 95  |
| ISO .....                     | 113 |

**L**

|                           |     |
|---------------------------|-----|
| Label .....               | 107 |
| labels .....              | 110 |
| ldf_real_double .....     | 81  |
| ldf_real_float .....      | 81  |
| light_gray .....          | 90  |
| Line .....                | 153 |
| line_switch .....         | 164 |
| linear_eccentricity ..... | 221 |

**M**

|                                 |     |
|---------------------------------|-----|
| magenta .....                   | 90  |
| matrix .....                    | 95  |
| Matrix .....                    | 80  |
| MAX_REAL .....                  | 81  |
| MAX_REAL_SQRT .....             | 82  |
| MAX_Z .....                     | 114 |
| MEAN_Z .....                    | 114 |
| measurement_units .....         | 119 |
| measurement_units (Point) ..... | 10  |
| MIN_Z .....                     | 114 |

**N**

|                               |     |
|-------------------------------|-----|
| name .....                    | 87  |
| NO_SORT .....                 | 114 |
| normal .....                  | 156 |
| null_coordinates .....        | 81  |
| number_of_points .....        | 215 |
| number_of_polygon_types ..... | 259 |
| numerical_eccentricity .....  | 221 |

**O**

|                     |                             |
|---------------------|-----------------------------|
| on_free_store ..... | 87, 118, 165, 204, 210, 247 |
| orange .....        | 90                          |
| orange_red .....    | 90                          |
| origin .....        | 121                         |
| out_stream .....    | 53, 91                      |

**P**

|                                      |               |
|--------------------------------------|---------------|
| PARALLEL_X_Y .....                   | 113           |
| PARALLEL_X_Z .....                   | 113           |
| PARALLEL_Z_Y .....                   | 113           |
| Path .....                           | 27, 164       |
| PATH .....                           | 247           |
| paths .....                          | 247           |
| pen .....                            | 119, 165      |
| pentagon_radius .....                | 263           |
| persp .....                          | 150           |
| PERSP .....                          | 113           |
| PI .....                             | 81            |
| Picture .....                        | 53, 110       |
| pink .....                           | 90            |
| Plane .....                          | 156           |
| point .....                          | 156           |
| Point .....                          | 10, 118       |
| Point::measurement_units .....       | 10            |
| Point::projective_coordinates .....  | 10            |
| Point::user_coordinates .....        | 10            |
| Point::view_coordinates .....        | 10            |
| Point::world_coordinates .....       | 10            |
| point_pair .....                     | 120           |
| points .....                         | 166           |
| Polygon .....                        | 35, 198       |
| Polyhedron .....                     | 47, 259       |
| position .....                       | 108, 150, 153 |
| projective_coordinates .....         | 118           |
| projective_coordinates (Point) ..... | 10            |
| projective_extremes .....            | 119, 165, 247 |
| pt .....                             | 107           |
| purple .....                         | 90            |

**R**

|                          |          |
|--------------------------|----------|
| radius .....             | 204, 237 |
| real .....               | 80       |
| real_pair .....          | 80       |
| real_short .....         | 80       |
| real_triple .....        | 80       |
| Rectangle .....          | 35, 210  |
| RECTANGLE .....          | 247      |
| rectangles .....         | 247      |
| red .....                | 90       |
| red_part .....           | 87       |
| Reg_C1_Plane_Curve ..... | 35, 215  |
| Reg_Polygon .....        | 35, 204  |
| REG_POLYGON .....        | 247      |
| reg-polygons .....       | 247      |

**S**

|                   |     |
|-------------------|-----|
| Shape .....       | 92  |
| shapes .....      | 110 |
| short .....       | 204 |
| Solid .....       | 247 |
| Solid_Faced ..... | 256 |

**T**

Tetrahedron ..... 47, 259  
tex\_stream ..... 91  
text ..... 107  
transform ..... 110, 118, 150  
Transform ..... 18, 95  
triangle\_radius ..... 259, 265  
Trunc\_Octahedron ..... 268  
Truncated Octahedron ..... 268

**U**

UNDRAW ..... 92  
UNDRAWDOT ..... 92  
UNFILL ..... 92  
UNFILLDRAW ..... 92  
up ..... 150  
use\_name ..... 87  
user\_coordinates ..... 118  
user\_coordinates (Point) ..... 10  
user\_transform ..... 95

**V**

vertex\_radius ..... 259  
vertices ..... 256  
view\_coordinates ..... 118  
view\_coordinates (Point) ..... 10  
violet ..... 90  
violet\_red ..... 90

**W**

white ..... 90  
width ..... 257  
world\_coordinates ..... 118  
world\_coordinates (Point) ..... 10

**Y**

yellow ..... 90  
yellow\_green ..... 90

# Function Index

~

~Cuboid..... 258  
 ~Path..... 170  
 ~Point..... 123  
 ~Solid..... 248

## A

align\_with\_axis ..... 104, 177  
 angle..... 138  
 angle\_point..... 216, 228  
 append..... 171  
 apply\_transform..... 93, 134, 179, 253

## B

beginfig..... 91  
 bool\_point ..... 120  
 bool\_point::operator= ..... 120  
 bool\_point\_quadruple..... 120, 121  
 bool\_point\_quadruple::operator=..... 121  
 bool\_real\_point..... 121  
 bool\_real\_point::operator= ..... 121

## C

Circle..... 237  
 clean ..... 106, 129  
 clear ..... 93, 112, 129, 172, 255  
 Color..... 87  
 convert-eps ..... 78  
 convert-eps-loop..... 78  
 corner..... 212  
 create\_new ..... 83  
 create\_new<Circle>..... 237  
 create\_new<Color>..... 88  
 create\_new<Cuboid>..... 258  
 create\_new<Ellipse>..... 223  
 create\_new<Path>..... 170  
 create\_new<Point>..... 122  
 create\_new<Rectangle> ..... 211  
 create\_new<Reg\_Polygon> ..... 206  
 create\_new<Solid>..... 248  
 cross\_product ..... 136  
 Cuboid..... 257

## D

define\_color\_mp..... 89  
 do\_transform ..... 223  
 Dodecahedron ..... 263  
 dot\_product ..... 135  
 dotlabel..... 148, 191, 224  
 draw ..... 144, 179, 254

draw\_axes ..... 183  
 draw\_help ..... 145, 146, 182  
 draw\_in\_circle..... 207  
 draw\_in\_ellipse..... 214  
 draw\_in\_rectangle..... 236  
 draw\_net..... 262, 265, 267  
 draw\_out\_circle ..... 208, 209  
 draw\_out\_ellipse..... 213  
 draw\_out\_rectangle..... 236  
 drawarrow..... 146, 182  
 drawdot..... 143

## E

Ellipse..... 221  
 endfig..... 91  
 epicycloid\_pattern\_1..... 244  
 epsilon ..... 99, 128  
 extract ..... 94, 149, 196, 253

## F

fill..... 185, 186, 254  
 filldraw..... 186, 254  
 Focus..... 151

## G

get\_all\_coords..... 127  
 get\_axis\_h..... 212, 227  
 get\_axis\_v..... 212, 227  
 get\_blue\_part ..... 89  
 get\_center ..... 198, 226, 249  
 get\_circle\_center..... 250  
 get\_circle\_ptr..... 251  
 get\_coefficients ..... 216, 234  
 get\_coord ..... 127  
 get\_copy..... 92, 108, 125, 172, 248  
 get\_diameter ..... 239  
 get\_direction ..... 152  
 get\_distance..... 152, 158  
 get\_element ..... 98  
 get\_ellipse\_center..... 250  
 get\_ellipse\_ptr..... 252  
 get\_endianness ..... 84  
 get\_extremes..... 94, 149, 196, 254  
 get\_focus ..... 226  
 get\_green\_part..... 89  
 get\_last\_point..... 194  
 get\_line..... 139, 194  
 get\_line\_switch..... 193  
 get\_linear\_eccentricity ..... 227  
 get\_maximum\_z..... 94, 149, 196, 254  
 get\_mean\_z..... 94, 149, 196, 254  
 get\_minimum\_z..... 94, 149, 196, 254

get\_name ..... 89  
 get\_net ..... 261, 264, 267, 269  
 get\_normal ..... 194  
 get\_numerical\_eccentricity ..... 227  
 get\_path ..... 154  
 get\_path\_ptr ..... 252  
 get\_persp ..... 152  
 get\_persp\_element ..... 152  
 get\_plane ..... 194  
 get\_point ..... 193  
 get\_position ..... 152  
 get\_radius ..... 206, 239  
 get\_rectangle\_center ..... 250  
 get\_rectangle\_ptr ..... 252  
 get\_red\_part ..... 89  
 get\_reg\_polygon\_center ..... 250  
 get\_reg\_polygon\_ptr ..... 252  
 get\_register\_width ..... 85  
 get\_second\_largest ..... 86  
 get\_shape\_center ..... 249  
 get\_shape\_ptr ..... 251  
 get\_size ..... 194  
 get\_transform ..... 125, 152  
 get\_transform\_element ..... 152  
 get\_up ..... 152  
 get\_use\_name ..... 89  
 get\_w ..... 128  
 get\_x ..... 127  
 get\_y ..... 128  
 get\_z ..... 128

## H

half ..... 219  
 hex\_pattern\_1 ..... 241

## I

Icosahedron ..... 266  
 in\_circle ..... 206  
 in\_ellipse ..... 213  
 in\_rectangle ..... 235  
 initialize\_colors ..... 89  
 initialize\_io ..... 91  
 intersection\_line ..... 161  
 intersection\_point ..... 142, 160, 197  
 intersection\_points ..... 199, 201, 216, 229, 230, 239  
 inverse ..... 98  
 is\_32\_bit ..... 85  
 is\_64\_bit ..... 85  
 is\_big\_endian ..... 85  
 is\_circular ..... 238  
 is\_cubic ..... 215, 226  
 is\_cycle ..... 193  
 is\_elliptical ..... 226  
 is\_identity ..... 98, 125  
 is\_in\_triangle ..... 126

is\_linear ..... 193  
 is\_little\_endian ..... 85  
 is\_on\_free\_store ..... 89, 93, 125, 193, 249  
 is\_on\_line ..... 140  
 is\_on\_plane ..... 125  
 is\_on\_segment ..... 139  
 is\_planar ..... 193  
 is\_quadratic ..... 215, 226  
 is\_quartic ..... 215, 226  
 is\_rectangular ..... 212

## K

kill\_labels ..... 113

## L

label ..... 147, 190, 223  
 Line ..... 153, 154  
 location ..... 216, 227

## M

magnitude ..... 137  
 mediate ..... 141  
 mid\_point ..... 212  
 modify ..... 89

## O

operator!= ..... 88, 125, 158  
 operator& ..... 171  
 operator&= ..... 171  
 operator\* ..... 97, 98, 124  
 operator\*+ ..... 92, 96, 97, 111, 123, 124, 170, 198, 223, 248  
 operator+ ..... 123, 171  
 operator+= ..... 111, 123  
 operator+= ..... 170, 171  
 operator- ..... 123, 124  
 operator-= ..... 123  
 operator/ ..... 124  
 operator/= ..... 124  
 operator<< ..... 88, 149  
 operator= ..... 88, 96, 111, 123, 151, 154, 157, 206, 211, 223, 238, 248, 258  
 operator= (for Points) ..... 11  
 operator== ..... 88, 124, 158  
 out\_circle ..... 208  
 out\_ellipse ..... 212  
 out\_rectangle ..... 235  
 output ..... 94, 108, 114, 149, 196, 253



**P**

Path ..... 166, 167, 169, 170  
 persp\_0 ..... 270  
 Picture ..... 110, 111  
 Plane ..... 156, 157  
 Point ..... 122  
 Point::intersection\_points ..... 72  
 Point::operator= ..... 11  
 Point::set ..... 11  
 project ..... 134, 196

**Q**

quarter ..... 219

**R**

real\_triple ..... 80  
 Rectangle ..... 210, 211  
 Reg\_Polygon ..... 204  
 reset ..... 106  
 reset\_angle ..... 152  
 reset\_transform ..... 113, 129  
 reverse ..... 195  
 rotate.. 93, 104, 112, 129, 173, 177, 199, 225, 253

**S**

scale ..... 93, 100, 112, 131, 173, 199, 225, 253  
 segment ..... 218  
 set ..... 87, 88, 122, 151, 167, 168, 169, 205, 211, 222, 237, 261  
 set (for Points) ..... 11  
 set\_blue\_part ..... 89  
 set\_connectors ..... 173  
 set\_cycle ..... 195  
 set\_dash\_pattern ..... 173  
 set\_draw\_color ..... 173  
 set\_element ..... 98  
 set\_extremes ..... 94, 149, 196, 253  
 set\_fill\_color ..... 173  
 set\_fill\_draw\_value ..... 173  
 set\_green\_part ..... 89  
 set\_name ..... 88

set\_on\_free\_store ..... 92, 129, 172, 249  
 set\_pen ..... 173  
 set\_red\_part ..... 89  
 set\_transform ..... 113  
 set\_use\_name ..... 88  
 shear ..... 93, 101, 132, 174, 199, 225, 253  
 shift... 93, 101, 112, 133, 175, 176, 199, 225, 253  
 shift\_times ..... 102, 133, 177, 199, 225  
 show.. 89, 93, 99, 113, 148, 152, 154, 162, 191, 252  
 show\_colors ..... 192  
 show\_transform ..... 113, 148  
 size ..... 193  
 slope ..... 139, 193  
 Solid ..... 248  
 solve ..... 216, 234  
 solve\_quadratic ..... 270  
 subpath ..... 193  
 suppress\_labels ..... 116  
 suppress\_output ..... 94, 149, 196, 253

**T**

Tetrahedron ..... 260  
 Transform ..... 95  
 trunc ..... 270  
 Trunc\_Octahedron ..... 268

**U**

undraw ..... 145, 188, 255  
 undrawdot ..... 144  
 unfill ..... 188, 255  
 unfilldraw ..... 189, 255  
 unit\_vector ..... 138  
 unsuppress\_labels ..... 117  
 unsuppress\_output ..... 94, 196, 253

**V**

void ..... 149

**W**

write\_footers ..... 91

# Concept Index

## A

animation ..... 64, 65  
 arbitrary Path ..... 72

## B

B-splines ..... 275  
 Bézier curves ..... 275  
 bugs ..... 17

## C

CD-R (Compact Disk, Recordable) ..... 77  
 Compact Disk, Recordable (CD-R) ..... 77  
 Comprehensive T<sub>E</sub>X Archive Network (CTAN) .. 2  
 connecting Points ..... 23  
 connectors ..... 27, 72  
 contributing to 3D<sub>L</sub>D<sub>F</sub> ..... 72  
 control points ..... 27  
 controls ..... 27  
 convert (ImageMagick) ..... 76  
 CTAN (Comprehensive T<sub>E</sub>X Archive Network) .. 2  
 curl ..... 27

## D

derivation ..... 274  
 derived classes ..... 274  
 display (ImageMagick) ..... 77  
 drawing and filling ..... 23

## E

Emacs ..... 91  
 Emacs-Lisp ..... 78  
 Encapsulated PostScript (EPS) ..... 4, 6, 76, 78  
 EPS (Encapsulated PostScript) ..... 4, 6, 76, 78

## F

FDL, GNU Free Documentation License ..... 281  
 file, output ..... 143  
 function templates ..... 73  
 function, member ..... 3  
 future plans ..... 72

## H

help lines ..... 145  
 hidden surface algorithm ..... 67  
 homogeneous coordinates ..... 18

## I

identity matrix ..... 19  
 ImageMagick ..... 76, 77  
 ImageMagick convert ..... 76  
 ImageMagick display ..... 77  
 input routine ..... 10  
 intersection ..... 72  
 intersection points ..... 72  
 intersection theory ..... 72  
 invariance, projective ..... 275  
 inversion ..... 20

## K

kludge ..... 270

## L

linear Paths ..... 164  
 lines, drawing ..... 23  
 local variable lists ..... 91

## M

matrix inversion ..... 20  
 matrix operations ..... 19  
 matrix, identity ..... 19  
 measurement units ..... 10  
 member function ..... 3  
 Metafont ..... 6  
 MetaPost ..... 6  
 multi-threading ..... 276  
 multiple inheritance ..... 274

## N

non-arbitrary Path ..... 72  
 non-uniform rational B-splines (NURBS) ..... 275  
 NURBS (non-uniform rational B-splines) ..... 275

## O

operations, matrix ..... 19  
 output file ..... 53, 72, 143  
 output files ..... 53

## P

painter's algorithm ..... 67  
 patches ..... 275  
 Path connectors ..... 72  
 Path intersections ..... 72  
 paths ..... 27

pen expression . . . . . 143  
pens . . . . . 23  
PNG (Portable Network Graphics) . . 4, 76, 78, 277  
Points, connecting . . . . . 23  
Portable Network Graphics (PNG) . . 4, 76, 78, 277  
PostScript (PS) . . . . . 4, 76, 78  
PostScript, structured . . . . . 76, 78  
projective invariance . . . . . 275  
PS (PostScript) . . . . . 4, 76, 78

## R

raw MetaPost code . . . . . 57  
reflections . . . . . 275  
RGB (red-green-blue) . . . . . 87

## S

shading . . . . . 275

shadows . . . . . 275  
spline curves . . . . . 275  
splines . . . . . 275  
structured PostScript . . . . . 76, 78  
surface hiding . . . . . 67  
surface patches . . . . . 275  
symbols . . . . . 4  
system dependencies . . . . . 81

## T

template functions . . . . . 73  
templates . . . . . 73  
tension . . . . . 27  
theory of intersection . . . . . 72  
TO DO . . . . . 57, 82

## U

units of measurement . . . . . 10