

# **EXCOR<sup>®</sup> Pediatric VAD**

***Ventricular Assist Device***

***with***

***Stationary Driving Unit Ikus Rev. 2.1***

Instructions for Use 1000721x09 Revision 8

For products in USA:

Humanitarian Device. Authorized by Federal law for use in the treatment of pediatric patients with severe isolated left ventricular or biventricular dysfunction who are candidates for cardiac transplant and require circulatory support. The effectiveness of this device for this use has not been demonstrated.

*This page was left blank intentionally*



**Notify Berlin Heart! 866.249.0128**

---

**This instruction for use corresponds to the following product versions:**

- Ikus software from V 3.41 forward
- Laptop software from V 3.50 forward
- Laptop from CF30 forward

**Manufacturer**

Berlin Heart GmbH  
Wiesenweg 10  
12247 Berlin  
Germany  
www.berlinheart.com

**Distributor**

Berlin Heart, Inc  
200 Valleywood, Suite B100  
The Woodlands, TX 77380  
USA

**Imprint**

© 2015-08  
Berlin Heart GmbH  
Wiesenweg 10  
12247 Berlin  
Germany

**Office Phone: 1.281.863.9700**

**Office Fax: 1.281.863.9701**

info@berlinheart.com

All rights reserved.

This instruction for use (IFU) may not be reproduced, transmitted, transferred onto an electronic medium, stored in an electronic data processing system nor translated into another language, either in parts or as a whole, without the express prior written permission of Berlin Heart GmbH. Excluded are the sample copies contained in this instruction for use.

This instruction for use is intended for information purposes only. The contents of the instruction for use may be supplemented, modified or updated at any time without prior notice.

Any previous versions of the IFU become obsolete upon release of this version.

**Licenses, trademarks and trade names**



Berlin Heart<sup>®</sup>, and EXCOR<sup>®</sup> are trademarks of Berlin Heart GmbH. They are protected by the relevant legislation in Germany and other countries.

All other trademarks or brands mentioned in this instruction for use are acknowledged as being the property of the respective owners. These rights are specifically recognized and respected whenever such trademarks or brands are mentioned in this instruction for use.

**Text and layout**

Berlin Heart GmbH

*This page was left blank intentionally*

# Content

	<b>Dear readers,</b>	<b>1</b>
<b>1</b>	<b>Important safety information</b>	<b>3</b>
1.1	Warnings .....	3
1.1.1	Storage and durability .....	4
1.1.2	Transport within the clinic .....	4
1.1.3	Device configurations .....	5
1.1.4	Procedural techniques - Ikus .....	5
1.1.5	Packaging and sterilization .....	7
1.1.6	Procedural techniques - pumps, cannulae, accessories .....	8
1.1.7	System .....	12
1.1.8	Procedures to minimize risk of thrombosis .....	13
1.1.9	Cleaning the components .....	13
1.1.10	Maintenance .....	14
1.1.11	Errors and corrective measures .....	14
1.1.12	Replacing the blood pump(s) .....	16
1.1.13	Driving blood pump(s) with the manual pump .....	16
1.1.14	Ambient conditions .....	17
1.1.15	Interaction with other procedures and therapies .....	17
1.2	Precautions .....	18
1.2.1	VAD placement technique .....	18
1.2.2	Ambient conditions .....	19
1.2.3	Caution while on device support .....	19
1.2.4	Transport outside the clinic .....	20
1.2.5	Battery replacement and disposal .....	20
1.3	Obligations of the operator .....	20
<b>2</b>	<b>General Information</b>	<b>21</b>
2.1	Device description .....	21
2.2	Indications for use .....	21
2.3	IDE Clinical Study Summary .....	21
2.4	Intended operation environment .....	21
2.5	Contraindications .....	22
2.6	Potential adverse events .....	22
2.7	Storage and durability .....	22
2.8	Battery replacement and disposal .....	23
2.9	Manufacturer's warranty .....	23
<b>3</b>	<b>Summary of Clinical Studies</b>	<b>25</b>
3.1	Indications for use .....	25
3.2	Contraindications .....	25
3.3	Alternative Practices or Procedures .....	25
3.4	Marketing History .....	25
3.5	Potential Adverse Effects .....	25
3.6	IDE Clinical Study .....	28
3.6.1	IDE Clinical Study Summary .....	28
3.6.2	Study Cohorts .....	28
3.6.3	Inclusion/Exclusion Criteria .....	29
3.6.4	Study Enrollment .....	30
3.6.5	Subject Demographics .....	32
3.6.6	Results .....	35
3.6.6.1	Probable Benefit .....	35
3.6.6.2	Primary Safety .....	43
3.6.6.3	Death information .....	46

3.6.7	Conclusion.....	47
3.7	Post Approval Study Summary.....	48
3.7.1	Study Objective .....	48
3.7.2	Study Design .....	48
3.7.3	Study Population .....	48
3.7.4	Data source .....	49
3.7.5	Key Study Endpoints .....	49
3.7.6	Total number of Enrolled Study Sites and Subjects, Follow-up Rate .....	49
3.7.7	Study visits and length of follow-up .....	49
3.7.8	Results .....	50
3.7.8.1	Primary Safety .....	50
3.7.8.2	Primary Efficacy Endpoints.....	51
3.7.8.3	Study Strength and Weaknesses .....	52
<b>4</b>	<b>Description: blood pump, cannulae and accessories</b>	<b>53</b>
4.1	EXCOR blood pumps .....	54
4.2	EXCOR cannulae .....	54
4.3	EXCOR accessories .....	55
<b>5</b>	<b>Description: Ikus</b>	<b>57</b>
5.1	Overview.....	57
5.2	Displays and operating elements .....	58
5.2.1	Connection panel .....	58
5.2.2	Display and operating panel.....	61
5.2.3	Power supply .....	61
5.3	Operating modes .....	62
5.3.1	Univentricular operation.....	62
5.3.2	Biventricular operation.....	62
5.4	Laptop computer with monitor program .....	63
5.5	Safety .....	63
5.5.1	Redundant design of pneumatic systems in univentricular operation .....	63
5.5.2	Redundant design of pneumatic systems in biventricular operation .....	64
5.5.3	Control computer with redundancy design .....	64
5.5.4	Battery operation .....	65
5.5.5	Manual pump.....	65
5.5.6	Password-protected user profiles (access passwords) .....	65
<b>6</b>	<b>Instructions for use: Ikus</b>	<b>67</b>
6.1	Start menu .....	68
6.1.1	Selecting an option in the start menu .....	69
6.1.2	Configuring user passwords .....	69
6.1.3	Saving data on USB stick .....	71
6.1.4	Changing date or time .....	71
6.2	Basic instructions for monitor program .....	71
6.2.1	Starting the monitor program.....	71
6.2.2	Shutting down the monitor program .....	72
6.2.3	Logging in and out of the monitor program.....	72
6.2.4	Logging in.....	72
6.2.5	Standard view – monitor program .....	73
6.2.6	Selecting monitor program options.....	74
6.2.7	Adjusting the parameter values .....	76
6.2.8	Browsing in the message window .....	77
6.3	Stopping the blood pump(s) and switching off the Ikus .....	77
6.3.1	Drive pause: stopping the Ikus temporarily .....	77
6.3.2	Pause left/ Pause right: stopping an individual blood pump .....	78
6.3.3	Drive OFF: switching the Ikus off.....	78
6.4	Switching between mains and battery operation .....	79

6.5	Changing over from univentricular to biventricular operation .....	82
6.5.1	Routine start-test when not in operation.....	83
6.6	Moving the Ikus .....	84
6.7	Transportation and packaging .....	84
6.7.1	Unloading the Ikus from the shipping crate .....	85
6.7.2	Loading the Ikus into the shipping crate.....	86
6.8	Cleaning and disinfection of the Ikus.....	90
<b>7</b>	<b>Commissioning the Ikus and setting parameters</b>	<b>93</b>
7.1	Preparatory steps outside of the operating room .....	93
7.1.1	Connecting the tank unit.....	94
7.1.2	Switching on the Ikus .....	95
7.1.3	Starting the monitor program.....	95
7.1.4	Setting the test parameters .....	95
7.2	Intraoperative drive management.....	97
7.2.1	Disconnecting the tank unit from the Ikus.....	97
7.2.2	Selecting the operating mode (view Select operating mode).....	97
7.2.3	Select the pump size .....	98
7.2.4	Select the cannula size .....	98
7.2.5	Display pump and cannula sizes.....	99
7.2.6	Setting the start-up parameters.....	100
7.2.7	Connecting the blood pump(s) to the Ikus.....	101
7.2.8	De-airing the blood pumps in single-step mode .....	102
7.2.9	Starting the blood pump (changing to standard view).....	102
7.2.10	Checking the parameters when the pump is started and adjusting them.....	103
7.2.11	Switching from CPB support to VAD support .....	105
7.2.12	Possible complications .....	106
7.3	Postoperative drive management.....	107
7.3.1	After transfer to the ward .....	107
7.3.2	Follow-up treatment.....	107
<b>8</b>	<b>Implantation: Preparations in the operating room</b>	<b>109</b>
8.1	Preparing the components and materials required.....	109
8.2	Checking and adjusting the settings of the cable tie gun .....	109
8.3	Unpacking the sterile components .....	111
8.4	Moving the membrane to the end-of-diastole position.....	112
8.5	De-airing the blood pump .....	112
8.5.1	Inserting the de-airing needle .....	113
8.5.2	Rinsing and filling the blood pump.....	113
<b>9</b>	<b>Implantation - surgical procedure</b>	<b>115</b>
9.1	Cannula exit sites .....	116
9.2	Use of the cannula tunneling tip .....	117
9.3	Cannulae, cannula extension set and connecting set .....	117
9.3.1	Description: Cannula extension and connecting sets.....	118
9.3.2	Instructions for Use: Cannula extension set and connecting set.....	119
9.4	Access .....	121
9.5	LV apex cannula.....	121
9.5.1	Anastomosis of inflow cannula with LV apex.....	122
9.5.2	Creating a transcutaneous tunnel for the LV apex cannula.....	123
9.6	Atrial cannula(e) .....	124
9.6.1	Creating a transcutaneous tunnel for atrial cannula(e).....	124
9.6.2	Anastomosis of atrial cannulae.....	125
9.7	Arterial cannula(e) .....	126
9.7.1	Creating a transcutaneous tunnel for arterial cannula.....	126
9.7.2	Anastomosis of the arterial cannula .....	127
9.8	Shortening the cannulae if necessary .....	128

9.9	Connecting the blood pumps to the cannulae .....	128
9.10	Removing the de-airing needle.....	130
9.11	Securing the connections .....	130
<b>10</b>	<b>Implantation - anesthesia</b>	<b>133</b>
<b>11</b>	<b>Wound care and treatment</b>	<b>135</b>
11.1	Removing the old dressings .....	136
11.2	Cleaning the blood pump.....	137
11.3	Cleaning of the wound.....	137
11.4	The new dressing .....	138
11.4.1	Preparing a new dressing.....	138
11.4.2	Applying a new dressing.....	138
11.5	Regular checks of blood pump(s) and cannulae .....	141
11.5.1	Visual inspection: pump filling and ejection .....	141
11.5.2	Visual inspection: deposits .....	142
11.5.3	Checks using the monitor program.....	143
11.5.4	Replacing the blood pump due to growth of the patient .....	144
<b>12</b>	<b>Anticoagulation therapy</b>	<b>145</b>
12.1	Before Implantation of the EXCOR.....	145
12.1.1	General considerations.....	145
12.1.2	Pre implantation .....	145
12.2	During Implantation - Cardiopulmonary Bypass .....	145
12.2.1	Cardiopulmonary Bypass (CPB).....	145
12.2.2	Post CPB .....	145
12.3	Postoperative anticoagulation therapy .....	145
12.3.1	General Considerations.....	145
12.3.2	Starting anticoagulation therapy .....	145
12.3.3	Unfractionated heparin therapy (i.v.) Patient < 12 months .....	146
12.3.4	Unfractionated heparin therapy (i.v.) Patient ≥ 12 months .....	146
12.3.5	Thrombelastography (TEG®).....	147
12.4	Low Molecular Weight Heparin.....	147
12.5	Oral Anticoagulation Therapy (only for patients ≥ 12 months of age who are taking a full oral diet).....	147
12.6	Monitoring of Blood Count and Anticoagulation Status .....	148
12.7	Postoperative platelet inhibition therapy .....	148
12.7.1	Start of therapy .....	148
12.8	Adjunctive Medication .....	149
12.9	Anticoagulation Therapy.....	149
12.9.1	Therapeutic Heparin administration and adjustment.....	149
<b>13</b>	<b>Weaning and Explantation for BTR and BTT</b>	<b>153</b>
13.1	Weaning Procedure .....	153
13.1.1	Introduction.....	153
13.1.2	Indication .....	153
13.1.3	Eligibility Criteria .....	153
13.1.4	Weaning Protocol .....	154
13.1.5	10 ml / 15 ml pump.....	154
13.1.6	25 / 30 ml pump.....	158
13.1.7	50 / 60 ml pump.....	162
13.1.8	Explantation Criteria .....	166
13.2	Explantation for BTR .....	167
13.2.1	Explantation with univentricular support.....	167
13.2.2	Explantation after biventricular support .....	167
13.3	Explantation for BTT .....	168



<b>14</b>	<b>Error Messages and corrective measures</b>	<b>171</b>
14.1	Pressure error / time error in system 1 (or in system 2 or 3) .....	173
14.2	Throttle valve error in system 1 (or system 2 or 3) .....	173
14.3	Please connect driving tube .....	174
14.3.1	Replacing a driving tube .....	174
14.4	Please check left / right pump and driving tube .....	175
14.5	Backup operation left/right.....	176
14.6	Error messages in emergency operating mode.....	176
14.6.1	UVAD, emergency operation!. Contact service immediately!.....	176
14.6.2	Emergency operation system 1 (or system 2 or 3). Contact Service now!.....	177
14.7	System 1 (or system 2) is defective!.....	177
14.8	System 3 (backup) is defective!.....	178
14.9	Alarm circuit fault: buzzer remains off (or on).....	178
14.10	Backup computer faulty! Contact customer service. ....	178
14.11	Backup computer.....	179
14.11.1	... reports discrepancy in left/right pump output measurements!.....	179
14.11.2	... reports faulty measurements on the left (or right).....	179
14.11.3	... reports an error in output measurement on the left (or right) pump.....	179
14.11.4	... reports faulty test.....	180
14.12	Measurement discrepancy in main computer (backup computer).....	180
14.13	Parameter set update failure .....	181
14.14	Temperature sensors: <<8-digit binary code>>.....	181
14.15	Fault: <<16-digit binary code>> (<<type of fault>>) .....	182
14.16	Batteries discharged; battery operation not possible.....	182
14.17	Insufficient battery charge. Only limited battery operation.....	183
14.18	Error messages - Circuit breaker and internal battery fuse .....	183
14.19	Electronic malfunction. Contact customer service!.....	183
14.20	Acoustic alarm is not properly recognized .....	184
14.21	Error: no data/no reaction from the control computer .....	184
14.22	Left/right flow sensor defective. Notify Service!.....	185
14.23	Problem: <<Text>> .....	186
14.24	Self-test is not completed by passive computer! .....	186
14.25	Error messages during the start-up test .....	187
14.25.1	Battery test skipped (Battery problem!) .....	187
14.25.2	Additional messages during the start-up test .....	187
14.26	Discrepancy in pressure measurement: system 1 (or system 2 or 3) .....	188
14.27	Communication with Laptop failed.....	189
<b>15</b>	<b>Troubleshooting and correcting faults</b>	<b>191</b>
15.1	Replacing the blood pump(s).....	195
15.1.1	Preparing a replacement blood pump .....	195
15.1.2	Replacing the right blood pump (RVAD/ BVAD).....	196
15.1.3	Replacing the left blood pump (LVAD/ BVAD) .....	197
15.2	Restarting Ikus.....	198
15.3	Emergency pulse mode.....	200
15.3.1	Emergency pulse mode - switching the Ikus off .....	201
15.3.2	Ikus start-test following emergency pulse mode.....	201
15.4	Connecting the patient to a replacement Ikus .....	202
15.5	Driving blood pump(s) with the manual pump .....	204
15.6	Mains failure or breakdown of both control computers.....	206
15.7	Reading out the LOG files .....	207
15.8	Circuit breaker and battery fuse .....	208
<b>16</b>	<b>Appendix</b>	<b>211</b>
16.1	Overview: Product range and possible combinations.....	211
16.1.1	Blood pumps .....	211
16.1.2	Overview: Relationship: body weight – pump size .....	211

16.1.3	LV apex cannulae.....	212
16.1.4	Atrial cannulae.....	212
16.1.5	Arterial cannulae .....	212
16.1.6	Overview: Which cannulae should be used for which pump? .....	214
16.1.7	System accessories.....	215
16.1.8	Driving unit .....	215
16.1.9	Special components .....	215
16.1.10	Maximum rates for the pump-cannula combinations.....	216
16.1.11	Blood pump combinations in biventricular mode .....	217
16.1.12	Relative systolic duration.....	217
16.2	Technical specifications.....	217
16.3	Symbols and tags .....	220
16.4	Sample copy: Ikus Incoming Checklist .....	221
16.5	Implantation record form.....	222
16.6	Sample copy: EXCOR pump log .....	227
16.7	Pump performance flow sheet.....	230
<b>17</b>	<b>EMC tables</b>	<b>231</b>
17.1	Essential Performance .....	231
17.2	Electromagnetic emissions.....	231
17.3	Electromagnetic immunity - part 1 .....	231
17.4	Electromagnetic immunity - part 2 .....	232
17.5	Recommended separation distances between portable and mobile RF communications equipment and the Ikus .....	234
	<b>Index</b>	<b>237</b>

## Dear readers,

This Instructions for Use is intended for all medical personnel involved in caring for a patient who is being supported by an EXCOR® Pediatric VAD (referred to as EXCOR in this instruction for use).

The instruction for use provides information on the structure, principle of operation and application of the EXCOR in conjunction with the Stationary Driving Unit Ikus (referred to as Ikus in this instruction for use). To ensure patient safety and comfort, please read the instruction for use carefully.

A Physicians Manual and the EXCOR Pediatric training slides are available as an additional resource for the medical personnel that are involved in caring for a patient who is being supported by an EXCOR® Pediatric VAD. Additionally, urgent clinical and technical assistance is available via the Berlin Heart Emergency Hotline. You can reach us 24 hours per day, 365 days per year at 866-249-0128.

Always make sure that only professional medical personnel who have been specifically trained in the use of the product are permitted to work with EXCOR.

Note: The recommendations in this manual are based on Berlin Heart's experience with the EXCOR. The decisions related to implantation, the components to be used, and patient care remain with the patient's physicians.

### The following pictograms and symbols are used in this instruction for use:



Indicates a hazardous situation which, if not avoided, **will** result in death or serious injury to the patient.



Indicates a hazardous situation which, if not avoided, **could** result in death or serious injury to the patient.



Indicates a hazardous situation which, if not avoided, could result in minor or moderate injury to the patient and/ or damage to the device.



Notes are practices not related to personal injury. Possible damage to the device.



This symbol identifies measures and procedures which have proved useful and successful in conjunction with EXCOR and which we therefore recommend.



**Notify Berlin Heart! 866.249.0128**

This is the telephone number of the emergency hotline. The hotline desk is in operation 24 hours a day. This number is intended for use by medical personnel and should be used in cases of emergency only.



1. Individual steps of the instructions are numbered in sequential order.

## Term definitions

### Product life

How long the product can be used. No maintenance or repairs are performed after this date. With unsterile products, the product life starts on the day of (initial) shipment; with sterile products it starts on the day of implantation. All sterile products are for single use only.

### Expiration date

How long the unused sterile product reliably maintains sterile. The device should not be used if the expiration date is past.

### Maintenance interval

Interval in which the product needs to be serviced.

### Warranty

In the case of justified claims, the company must choose to either repair or exchange the defective goods within a reasonable period of time. The buyer will be entitled to cancel or to reduce the order, in accordance with legal regulations, only when the defective goods should repeatedly fail or be deemed unacceptable. The buyer may not rectify the defects under any circumstances. The buyer is entitled to claims for defects only in accordance with item 5.5 of the General Business Terms and Conditions. (for additional information see section 5 of the Terms and Conditions)

### Warranty period

All warranty claims expire after 12 months, calculated from the time that risk is transferred (for additional information see section 5 of the General Terms and Conditions).

The precise application on the individual components of the EXCOR will be described in section 2.1: Device description, page 21.

## Definition of the used font formats

Description	Meaning
<b>bold, blue</b>	software texts (messages and menus) except in headings and lists
"text"	quotation
<key>	key on the laptop keyboard
<<filler text>>	e.g. if texts in error messages are various
[dimension unit]	dimension units in tables; e.g. [mmHg]

# 1 Important safety information

## 1.1 Warnings



---

Before using EXCOR, read the Instructions for Use carefully.

---

Only qualified medical personnel trained specifically in the use of the system are permitted to work with EXCOR. Training courses can be arranged with Berlin Heart, Inc. Use by untrained personnel can pose a risk to the patient and the EXCOR.

---

Before starting the Ikus, make sure that a replacement Ikus is available in the hospital. If a replacement Ikus is not available, there is a risk that the patient cannot be cared for in the event of device malfunction.

The general rule is:

- 1 replacement Ikus if 1 or 2 systems are in use,
- 2 replacement Ikus if 3 or 4 systems are in use,
- 3 replacement Ikus if 5 or 6 systems are in use.

If more than 6 systems are in use the number of replacement Ikus has to be 1/2 of the active systems.

---

On the system EXCOR only use components of this system. Never use other components than those delivered by Berlin Heart GmbH/ Berlin Heart Inc. Otherwise the warranty is no longer valid.

---

The Ikus and the components of the EXCOR system must not be modified. Otherwise the secure function of the system can not be guaranteed.

---

The Ikus should not be used adjacent to or stacked with other equipment. If adjacent or stacked use is necessary, the Ikus should be observed to verify normal operation in the configuration in which it will be used.

---

The system EXCOR Pediatric and its components are permitted to be used only by prescription of the attending physician.

---

To ensure the safety of the patient supported with the EXCOR pediatric the patient should be supervised by qualified medical personnel who have been trained on the use of the system.

---

Do not use the EXCOR if there is any visible damage of the Ikus or any of its components.

---

If there is any malfunction of the Ikus while the driving unit is connected to the patient, the Ikus must immediately be replaced.

---

### 1.1.1 Storage and durability



The expiration date of each EXCOR product is found on the product labels located on both the outer and inner packaging. The pumps, cannulae and accessories must not be used after the expiration date and even not be re-sterilized. Otherwise there is a risk of patient infection.

An EXCOR blood pump may not be used on a patient for more than 1 year. After this it shall be replaced with new products.

### 1.1.2 Transport within the clinic



To move the Ikus unit: push only, using the handle provided for this purpose. Avoid any sudden jerky motion. When passing over smaller obstructions, exercise extreme caution, pulling the Ikus unit backwards (i.e. handle first) across the obstruction if necessary.

To lift the Ikus: use only the lifting bars at the lower edge at each side of the unit to hold and lift it. Never attempt to lift the Ikus by its handle. The Ikus must always be lifted by at least 2 people, preferably 4.

Rolling the Ikus over sloping surfaces: ensure that the person pushing it is strong enough to push the Ikus in a controlled manner. The slope of the surface may not be steeper than 10° (exception: packing/unpacking of the Ikus into/ from the transport crate). Otherwise there is a risk of injury to the transporting persons or of damaging the Ikus!

If it is necessary to transport the patient within the clinic ensure that he is accompanied by a person trained to use the manual pump.

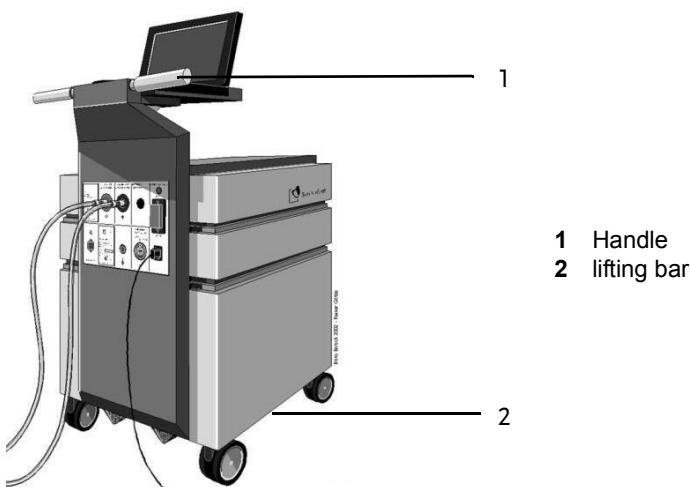

Fig. 1-1 Handle and lifting bar

### 1.1.3 Device configurations



---

EXCOR was not designed to be used in combination with other systems, nor do any of the currently granted approvals allow for this. Use by untrained personnel poses a risk to the patient and to the EXCOR.

---



---

In univentricular operation: Always connect the driving tube of the blood pump to the red marked connector.

---



---

The units may only be operated with the disposable products and accessories specified in this document. Also see section 16.1: Overview: Product range and possible combinations, page 211. Otherwise there is a risk of functional limitation and/or damage to the Ikus. Failure to observe this stipulation will invalidate all warranty agreements by Berlin Heart Inc..

---



---

The connection between the connector *External alarm* (Nurse call) and the internal alarm system of the clinic is not failsafe. The use of this feature does not release the user from supervising the *Ikus* and the displayed messages and alarms.

---

### 1.1.4 Procedural techniques - Ikus



---

Follow the numbered instructions exactly in their sequential order. Otherwise there is a risk of functional limitation or Ikus malfunction.

---



---

Protect the Ikus unit against dirt and contamination. Prevent foreign objects from falling or working their way into the connectors and ventilation slits. Keep all drive tube connectors covered at all times when not in use. Otherwise there is a risk of functional limitation and/or damage to the Ikus.

---



---

Place the Ikus driving unit on a firm and even surface.

---



---

Never place other objects on top of an Ikus driving unit.

---



---

When switching on the Ikus, always connect it to the mains power supply. This is the only way to ensure that the start test (see section 6.2.1: Starting the monitor program, page 71) is completed and that possible malfunctions are detected.

---

---

Only connect the mains cable of the Ikus driving unit to grounded mains power outlets. The supply voltage has to conform to the voltage requirements indicated on the Ikus identification plate. Only connect the mains cable of the Ikus driving unit to suitable power outlets complying with the electrical safety regulations of the country in which it is being used. Otherwise there is a risk of electrical shock or damage to the EXCOR system!

---

---

If there are several electrical devices in the vicinity of the patient, then these are to be connected to a central grounding point. The connector *Potential equalization* is to be used for this on the Ikus. Otherwise there is a risk of electric shock.

---

---

Switch on the Ikus 2 hours before use in order to sufficiently charge the batteries and to detect possible device errors during the start test see chapter 7.1.2: Switching on the Ikus, page 95. **IMPORTANT:** During this time, always connect both tank units to the Ikus (see section 7.1.1: Connecting the tank unit, page 94)! Otherwise there is a risk that error messages are falsely generated.

---

---

After switching on the Ikus, pull the key out of the main switch (key switch) and store it in a safe place.

---

---

The Ikus power switch (toggle switch) must be switched on during the first startup and remain set to *[I]* position. Its position should never be changed. Otherwise there is a risk that the batteries will not be fully charged after battery operation.

---

---

The Ikus is designed for stationary operation and to be run on mains power (referred to as the mains in this instruction for use). Do not run it on battery operation unless this is absolutely necessary (e. g. when moving the patient within the clinic or during a mains failure).

---

---

Always take the battery capacity limits into consideration when using the system. When the system is working in battery operation, the patient must be accompanied by a person trained to use the manual pump. Thus the patient shall be guaranteed care in an emergency.

---

---

The air vents must not be covered or obstructed during operation. Otherwise the Ikus will not receive sufficient ventilation, which may lead to overheating. This may lead to malfunctions and a malfunction in device operation.

---



---

Only disconnect the Ikus from the mains if the charge level indicator shows that the batteries are completely charged (all yellow LEDs are lit).

**IMPORTANT:** In order to prevent rapid and premature ageing of the batteries, the Ikus must always be run on the mains for at least 6 hours after using the battery operation. Only after this may the Ikus be run on battery operation again.

---

---

If the LEDs of the charge level indicator are blinking or the message **Batteries discharged - use power supply!** appears, immediately switch to mains operation! If the batteries are completely discharged (red LED of the charge level indicator is lit) and the drive continues to run on battery operation, there is the risk of a total malfunction of the Ikus and damage of the batteries. If this happens, it can not be guaranteed that the Ikus will restart after connecting it to the mains.

---

---

Whenever the Ikus is running in battery operation, the patient must be accompanied by a person trained to use the manual pump. Thus the patient shall be guaranteed care in an emergency.

---

---

To prevent the batteries from aging quickly, every period of battery operation should be followed by at least 6 h of mains operation.

---

---

When the battery charge is low, the acoustic signal sounds every minute. The Ikus must be connected to the mains operation immediately.

---

---

Messages are only displayed when the monitor program is running. When the monitor program is shut down, the only indications that there is an error message are an acoustic signal and the fact that the indicator lamp on the Ikus handle lights up. There is no way of finding out what type of error message has been displayed.

---

---

When reading out the log files: Make sure that you always have the USB stick inserted and that there is sufficient capacity on the stick. Otherwise the LOG files might get lost as they are deleted from the hard disk as soon as they have been transferred onto a USB stick.

---

### 1.1.5 Packaging and sterilization



---

EXCOR blood pumps and cannulae are intended for single-use only. Otherwise there is a risk of infection.

---

---

The sterile components are sterilized using ETO and are packed in a double-layer sterile package. Check that the various layers of the sterile packaging are not damaged in any way before they are opened. Do not use the components if either of the sterile packages are damaged. The same applies to sterile components which have exceeded the expiration date as printed on the label. Otherwise there is a risk that the product is no longer sterile.

---

---

EXCOR sterile components may not be resterilized by the user. Any opened product must be used or sent back to Berlin Heart. If product expires please contact Berlin Heart for exchange.

---

---

An aluminum-coated external packaging protects the Carmeda® BioActive Surface (CBAS) of the blood pump and its sterile packaging against fluctuations in relative humidity. Do not use blood pumps with damaged external packaging. Otherwise there is a risk that the CBAS coating may be compromised.

---

---

The following items are delivered in sterile condition: blood pumps, cannulae, cannula extension sets / connecting sets, driving tubes, de-airing set, de-airing hammer, tube connecting set, membrane set.

---

---

The external packaging and the outer surface of the outer sterile packaging are not sterile. These 2 packaging layers must be removed before the inner sterile packaging containing the product is handed over to the sterile field. Otherwise there is a risk that the sterile field will be contaminated.

---

### 1.1.6 Procedural techniques - pumps, cannulae, accessories



---

The preparation and use of blood pumps should only be performed by trained personnel. Surgical, nursing and perfusion personnel without experience in the use of EXCOR must complete the EXCOR Training Course which provides theoretical introduction and hands-on practical exercises in the operation of this system. The training program is organized and offered by Berlin Heart, Inc.

---

---

Only use sterile components which have been delivered in undamaged sterile condition (sterile packaging intact, expiration date not expired).

---

---

Only use blood pumps which have an undamaged aluminum-coated outer packaging.

---

---

The long-term storage conditions for all sterile products must be observed: temperature +15°C to 25°C, relative humidity: 35 % to 50 %. Store in a dry place! Otherwise there is a risk that the product is no longer sterile.

---

---

In order to prevent infection, use strict aseptic techniques during implantation and exercise extreme caution throughout the period of EXCOR cardiac support. Danger of infection!

---

---

The distal end of the cannulae can be trimmed. At least 5 cm (2 inches) of material without polyester velour covering should remain to allow visual inspection of the cannula/ titanium-connector junction. Otherwise there is a risk that possible deposits if formed, cannot be visualized.

---

---

Ensure proper placement of the cannulae, especially with respect to orientation of the LV apex cannula, to prevent suction of the myocardial wall.

---

---

Prior to initial operation of the blood pump(s) minimal initial start parameters have to be set on the laptop to ensure smooth transition from CPB to VAD support.  
When connecting the blood pump(s) to the cannulae always observe the arrows on the inflow and outflow stubs. They show the blood flow direction. There is a risk of injury to the patient and severe pump malfunction if the titanium connectors on the end of the inflow and outflow stubs are not connected to the appropriate cannulae.

---

---

Do not touch or manipulate the blood pumps and cannulae with pointed or sharp-edged objects (surgical instruments, wire brushes, etc.). Otherwise there is a risk of blood pump and cannula leakage.

---

---

Do not touch or manipulate the drive lines with pointed or sharp-edged objects (surgical instruments, wire brushes, etc.), otherwise these components could be damaged.

---

---

Creating a transcutaneous tunnel for the LV apex cannula: Always use cannula tunnelling tip, never use a sharp surgical instrument directly on the cannula.

---

### **Cannula extension set and connecting set**



---

If, on *further shortening* of the cannula, visual inspection of the titanium connector on the blood pump is no longer possible: use the cannula extension set.

---

---

The cannula extension set and the connecting set should only be used if necessary, since the basic risk of thrombogenesis and deposits increases each time the cannula is extended.

---

Do not combine the connecting set with staged cannulae in such a way that multiple diameters are bridged. Otherwise, the pump will not fill or empty completely.

Secure each of the connections with at least 1 cable tie. Otherwise, the connections may loosen over time and the cannula extension set / the connecting set may become separated from the blood pump.

All effort should be made to minimize the manipulation and distortion of the blood pumps and cannula during the removal of the cable tie(s) to prevent mobilization of deposits.

If it is necessary to clamp any other part of the cannula (cannula extension set / connecting set resp.) that is not covered with velour, cover the part that will be clamped with a gauze sponge.

When using a cannula extension set / a connecting set it may be necessary to shorten the respective connecting tube, but the minimum length must be maintained. See Tab. 1-1, page 10.

Article	Diameter / Diameter reduction	Minimum length
<b>Cannula extension set</b>		
A06-006	6 mm	55 mm
A09-009	9 mm	60 mm
A12-012	12 mm	75 mm
<b>Connecting set</b>		
A06-009	9 to 6 mm	60 mm
A09-012	12 to 9 mm	75 mm

**Tab. 1-1** Cannula extension set / connecting set: minimum length of tube section



Follow exactly the instructions for using the de-airing set. Otherwise there is a risk of membrane damage.

Ensure that cannulae, blood pump(s) and driving tubes are not subject to external forces, like compression, traction or torsion forces, and are free of knots or sharp bends. Prevent the cannulae and connectors from being exposed to tensile forces. Otherwise there is a risk of obstruction of the air and blood flow.

---

When positioning the driving tubes mitigate the risk of adverse tubing and line incidents by routing the driving tubes in a clear pattern toward the feet and to the side.

---

Do not initiate cardiac support with the EXCOR blood pumps until the blood pumps have been completely de-aired. After connecting the cannulae, ensure removal of all air that is still in the atria or ventricle by performing single steps (**Step left**, **Step right**) with subsequent removal of the bubbles inside the pump via the de-airing needle. Otherwise there is a risk of embolism.

---

When removing the de-airing needle, never pull on the de-airing tube, but rather only on the de-airing needle (see also Fig. 8-7, page 113).

---

Once the de-airing needle has been removed it cannot be re-inserted.

---

Rates < 60 bpm are intended to be used only for implantation and explantation. Never use the Ikus with a rate < 60 bpm without constant supervision.

---

Secure each connection between blood pump and cannula with at least one cable tie as soon as the proper function of the EXCOR is established (see section 9.11: Securing the connections, page 130). Otherwise there is a risk of loose connections and inadequate blood supply to the patient.

---

At least every 4 hours, visually check that the blood pump(s) is (are) filling and ejecting completely over a period of several pump cycles. If a pump is not filling and/ or ejecting completely, institute the appropriate corrective action.

---

Do not kink the drivelines. Otherwise there might not be sufficient pump output.

---

In no case should the cannulae either be kinked directly at the connector to the blood pump or at the transition area between velour and silicone.

---

Do not kink the cannulae needlessly. Otherwise there might not be sufficient pump output. Moreover, cannulae might be damaged.

---

Wound care and treatment: Before cleaning the wound (see section 11.3: Cleaning of the wound, page 137), put on sterile disposable gloves, cap and mask.

---

---

Weaning: If the patient does not meet the eligibility criteria at any time during the weaning process: Resume pumping at rate prior to any weaning (initial rate, IR).

---

### 1.1.7 System



---

If a non-matching pump-cannula-combination (see section 16.1.10: Maximum rates for the pump-cannula combinations, page 216) was chosen, use only the connector sets provided with the system in order to minimize the risk of clots at the junctions. Be aware of increased risk of thrombosis and hemolysis.

---

---

The cannula diameter may be adapted only once (either by using a staged cannula or a connector set.) Multiple staging could result in limited pump performance and compromised hemodynamics.

---

---

Do not install any additional software on the laptop. Otherwise there is a risk of damage to the original Ikus software. Risk of total malfunction of the Ikus!

---

---

Make sure that the **<NumLk>** and the **<Caps Lock>** key of the laptop is deactivated. The status LED on the laptop marked with a lock and/or a number (e.g. 1) should not be lit. Otherwise there is a risk of incorrect inputs.

---

---

Only use USB sticks included within the delivery of the EXCOR to store data. Do not use any other USB sticks with the laptop. Risk that a (wrong) USB stick is not recognized. If a (wrong) USB stick is recognized, then it may not be possible to save the data.

---

---

Never connect other USB devices to the USB port of the laptop than the delivered USB sticks. Otherwise there is a risk that the batteries of the Ikus will be discharged too fast.

---

---

Never connect wireless technology to the USB port of the laptop. Otherwise there is a risk of uncontrolled electromagnetic radiation which might interfere with other devices. The Ikus could also become more susceptible to emissions from other devices.

---

---

Prior to connecting and disconnecting the USB stick to the slot, the laptop must be switched off. Otherwise there is a risk that the USB stick will not be recognized. When removing the stick the stored data can be lost.

---

---

If the IkuS is operating in emergency pulse mode, immediately visually check whether the blood pump(s) is (are) filling and ejecting completely. If one pump is not filling and/or ejecting completely, the patient must be supported immediately using the manual pump (see section 15.5: Driving blood pump(s) with the manual pump, page 204). Otherwise there is a risk that the patient will not be supported sufficiently.

---



---

If the IkuS is operated by the backup system provide the patient immediately with a replacement IkuS.

---



---

Do not disconnect the IkuS from the mains power supply if the circuit breaker is triggered. Otherwise there is a risk that the driving unit immediately stops operating (see section 15.8: Circuit breaker and battery fuse, page 208).

---



---

Do not use water or fluids to cool the IkuS! Otherwise there is a risk of a short circuit or a malfunction of the device.

---

### 1.1.8 Procedures to minimize risk of thrombosis



---

Ensure complete filling/ejection of the pump.

---



---

When using staged cannulae or a cannula extension set / connecting set, the pumping rate may not be greater than the respective value found in Tab. 16-9, page 216, as the pump will not eject its full volume at higher rates.

---



---

At least every 4 hours, visually check of blood pump(s), visible part of cannulae, cannula extension set and connecting set for deposit formation.

---

### 1.1.9 Cleaning the components



---

Cleaning the pump and the driveline: Do not use any acetone or petroleum based products near the pump or drivelines. We recommend using only water or alcohol to clean the pump and the drive line.

**IMPORTANT:** Do not use any corrosive or colored solutions or organic solvents to clean the blood pump or drivelines as they may alter the surface of the product.

---

---

Cleaning the cannulae and transcutaneous exit site: Do not use any acetone or petroleum based products near the cannulae and the transcutaneous exit site.

We recommend using chlorhexidine to clean the cannulae and transcutaneous exit site.

**IMPORTANT:** Do not use any corrosive or colored solutions or organic solvents to clean the cannulae and transcutaneous exit site as they may alter the surface of the product.

---

---

Prevent liquids from spilling into the Ikus. Otherwise there is a risk of an electric shock and of a malfunction of the Ikus.

---

### 1.1.10 Maintenance



---

If the Ikus is not in operation, it requires maintenance every 6 months. If it is in operation, it requires maintenance after every 2000 hours of use. (In case of continuous operation, approx. 3 months)

---

---

If the ambient temperature is continuously above +30°C during operation, the maintenance interval or life of the batteries is reduced.

---

---

The Ikus shall only be serviced by Berlin Heart GmbH/ Berlin Heart, Inc. or those authorized by Berlin Heart GmbH. For this reason, this document does not contain any circuit or wiring diagrams. The maintenance is performed based upon the *Maintenance Instructions*. This document also includes a technical description of the Ikus.

---

---

Only replacement parts approved by the manufacturer may be used for repairs and servicing. Otherwise there is a risk of functional limitation or permanent damage of the Ikus.

---

### 1.1.11 Errors and corrective measures



---

Any time an error message has occurred, visually check that the blood pump(s) is (are) filling and ejecting completely over a period of several pump cycles, then address the error message with the appropriate corrective action.

---

---

Check all information and messages in the message window of the monitor program at least every 4 hours. Take the necessary measures and (if required) notify the service department of Berlin Heart, Inc. The message window only shows a limited number of messages. Otherwise there is a risk that older information and messages can no longer be read and therefore corrective actions for older messages may no longer be possible.

---



---

If a message with the content ... **Contact (customer) service (now)!** is displayed in the message field on the laptop, replace the Ikus immediately (see chapter 14: Error Messages and corrective measures, page 171).

---

If the emergency pulse mode is activated while the backup system is already active, the Ikus is no longer able to drive both pumps. In this case, the patient must immediately be supported using the manual pump (see section 15.5: Driving blood pump(s) with the manual pump, page 204). Otherwise there might not be sufficient pump output.

---

In order for a driving tube to be replaced, the pump must be stopped for a short time. If the left driving tube is being replaced in a driving unit providing biventricular support, the right pump must also be stopped while the driving tube is being replaced in order to avoid overloading of the pulmonary circulation (danger of pulmonary edema).

---

If the left pump is being replaced in a VAD providing biventricular support, the right pump must also be stopped while the pump is being replaced in order to avoid overloading the pulmonary circulation (danger of pulmonary edema).

---

Message **Left/right flow sensor defective Notify Service!**: Do not operate the Ikus without supervision! Otherwise an insufficient support of the patient might not be detected.

---

If the Ikus is operating in emergency pulse mode, the user must immediately visually check the blood pump(s) to determine whether the pump(s) are filling and ejecting completely. If one pump is not filling and/or ejecting completely the patient must be supported immediately with the replacement Ikus. Use the manual pump while securing the replacement Ikus (see section 15.4: Connecting the patient to a replacement Ikus, page 202 and section 15.5: Driving blood pump(s) with the manual pump, page 204 resp.). Otherwise there is the risk that the patient will not be supported sufficiently.

---

If the emergency pulse mode is activated while the backup system is already active, the Ikus is no longer able to drive both pumps. In this case the patient must be supported immediately with the replacement Ikus. Use the manual pump while securing the replacement Ikus (see section 15.4: Connecting the patient to a replacement Ikus, page 202 and section 15.5: Driving blood pump(s) with the manual pump, page 204 resp.). Otherwise there is the risk that the patient will not be supported sufficiently.

---

### 1.1.12 Replacing the blood pump(s)



---

When replacing a blood pump, follow the instruction given here. Otherwise the duration of the pump stop will be prolonged and the patient might suffer from inadequate support.

---

---

The blood pump may only be replaced under sterile conditions!

---

---

When connecting the blood pump(s), pay attention to the direction of the arrows on the inflow and outflow stubs! These show the direction of the blood flow.

---

---

The cable tie covering the EXCOR cannula on the stub of the blood pump should be removed carefully. Use an appropriate blunt tool. **IMPORTANT:** never use a sharp instrument, for example, a scalpel or scissors, to remove the cable tie. This may cause damage to the cannula.

---

---

If the left pump is being replaced in a VAD providing biventricular support, the right pump must also be stopped while the pump is being replaced in order to avoid overloading the pulmonary circulation (danger of pulmonary edema).

---

---

If air or blood collects between any of the layers of the membrane, replace the blood pump. Otherwise, support may be inadequate.

---

### 1.1.13 Driving blood pump(s) with the manual pump



---

The use of the manual pump is only permitted for medical personnel trained in the use of it.

---

---

Pay attention to the colored markings on the driving tubes and on the connectors of the manual pump. Otherwise, there is a risk of lung edema.

---

---

Always keep manual pump attached to the IkuS. Otherwise in an emergency situation the adequate support of the patient is not guaranteed.

---

---

Call one or more persons to assist. Otherwise in an emergency situation the adequate support of the patient is not guaranteed.

---

---

The driving tubes and cannulae should be arranged in a bend-free position. Otherwise in an emergency situation the adequate support of the patient is not guaranteed.

---

---

When operating the manual pump with 1 hand, do not block the valves with your feet (see valve "2" in Fig. 15-2, page 205).

---

### 1.1.14 Ambient conditions



---

Protect the Ikus from exposure to moisture and wetness. Never store or operate the Ikus in a damp environment (e.g. bathroom, etc.). Otherwise there is a risk of functional limitation and/or Ikus malfunction.

---

---

In terms of electromagnetic compatibility (EMC) the Ikus is subject to special precautions! Avoid exposure to strong electromagnetic radiation (as generated by mobile/cell phones and cordless phones when switched on, electromagnetic security systems etc.), see chapter 17: EMC tables, page 231. Otherwise there is a risk of electromagnetic disturbances and fault-free functioning of the Ikus cannot be guaranteed.

---

---

When using a cell phone in the immediate environment of an Ikus in operation please make sure to keep a distance of at least 0.77 m. For further information please refer to chapter 17: EMC tables, page 231.

---

---

When using an RFID device in the immediate environment of an *Ikus* in operation please make sure to keep a distance of at least 1 m. For further information please refer to chapter 17: EMC tables, page 231.

---

---

Protect the Ikus against temperatures below +10°C and above +30°C; this includes extreme temperature changes and overheating (e.g. direct sunlight or from heaters). Otherwise there is a risk of functional limitation and/or Ikus malfunction.

---

---

If an ambient temperature of +30°C is continuously exceeded during operation, the lifetime of the batteries is reduced. Therefore, a person trained to use the manual pump should always be present in this case. This should ensure patient care in case of emergency.

---

---

Use the Ikus as far away as possible from environments containing flammable gases and use extreme caution. Otherwise there is a risk of explosion or gas ignition. The Ikus would be severely limited in function or malfunction altogether as a result of this damage.

---

Also see section 16.2: Technical specifications, page 217.

### 1.1.15 Interaction with other procedures and therapies



---

The following procedure is not possible: Magnetic resonance imaging

---

---

EXCOR patients with prosthetic aortic valves may have increased risk of thromboembolism.

---

If EXCOR is used in interaction with other procedures and therapies, observe the movement of the membrane to determine whether the blood pump is filling and ejecting completely. If a pump is not filling and/or ejecting completely, stop the interacting procedure or therapy and institute the appropriate corrective action.

---

In terms of electromagnetic compatibility (EMC) the Ikus is subject to special precautions! When exposing Ikus to the procedures and therapies listed below please observe EMC regulations given in chapter 17: EMC tables, page 231.

---

For the following procedures and therapies, the manufacturer does not expect any harmful interaction with the Ikus due to the general electromagnetic shielding of the device (see chapter 17: EMC tables, page 231). However, these procedures and therapies must only be applied after consultation with the treating physician.

- Radiotherapy
  - Nuclear diagnostics / nuclear therapy
  - Electro-stimulation therapy
  - Therapeutic ultrasonic treatment (e.g. lithotripsy)
  - External defibrillation
- 

The following procedures and therapies have been tested in regard to their interaction with the Ikus and no harmful effects were found, however, these procedures and therapies must only be applied after consultation with the treating physician. Additionally the manufacturer does not guarantee that equivalent devices will not interfere.

- Diathermy
  - X-rays
  - Computed tomography
- 

## 1.2 Precautions

### 1.2.1 VAD placement technique



---

Implantation - anesthesia: There should be an adequate supply of pre-matched stored blood, fresh frozen plasma and platelet concentrates available for immediate transfusion if required.

---

Implantation - anesthesia: Keep blood product transfusions to a minimum. Blood transfusions may lead to the development of antibodies, which are known to promote coagulation and inflammatory response.

---

---

The titanium connectors of the blood pumps have sharp edges designed to minimise the risk of clot formation at the junction. Be careful to avoid cutting yourself while connecting the pump and the cannulae.

---

### 1.2.2 Ambient conditions



---

The Ikus is intended solely for use in a hospital setting.

---



---

Before putting the Ikus into operation, check that the ambient conditions are suitable (see section 16.2: Technical specifications, page 217).

---

### 1.2.3 Caution while on device support



---

When switching on the Ikus always make sure that the Ikus is switched on first and then the laptop and never vice versa! Otherwise there is a risk that during the start test error messages are falsely generated.

---



---

At least daily, the EXCOR cannulae should be inspected for signs of wear or damage. ADVICE: To avoid needless kinking of the cannulae use a mirror for inspection of the bottom side of the blood pump.

---



---

At least every 4 hours, check visually that the blood pump(s) is (are) filling and ejecting completely over a period of several pump cycles. If a pump is not filling and/ or ejecting completely, then take the appropriate corrective action.

---



---

Educate the patient, family and caregiver to avoid pulling, kinking or any activity that could put stress on the cannula. Remind them periodically of the importance of protecting the cannula and blood pump. Do not allow patient to belly flop, pull or stretch the cannula, as this may damage the cannula resulting in injury or death to the patient.

---



---

After changing over to biventricular operation the device is operating in separate mode. All parameters are reset to the default parameters (see Tab. 15-3, page 203). The patient-customized parameters have to be adjusted again.

---



---

Do not switch the Ikus off unless the batteries are fully charged (i.e. all yellow charge indicator LEDs are on).

---



---

Replacing the blood pump due to growth of the patient: In children, plan to replace the pump(s) with a larger pump(s) in good time, to prevent the possibility of inadequate support due to an insufficient discharge rate.

---

### 1.2.4 Transport outside the clinic



---

The crate may only be transported as described in section 6.7: Transportation and packaging, page 84. Do not tilt or overturn the Ikus when it is packed inside the transport crate. Otherwise there is a risk that the Ikus is damaged or destroyed.

---

---

Always observe a resting period of 6 hours after each transportation before switching on the Ikus! The temperature of the Ikus should get adapted to the ambient temperature.

---

---

Keep all driving tube connectors covered at all times when not in use.

---

Also refer to section 6.7: Transportation and packaging, page 84.

### 1.2.5 Battery replacement and disposal



---

Only Berlin Heart GmbH/ Berlin Heart, Inc. service staff or persons authorized by the Berlin Heart GmbH service department may replace the batteries and dispose of them in accordance with the respective regulations.

---

## 1.3 Obligations of the operator



---

Only qualified medical personnel trained specifically in the use of the system are permitted to work with EXCOR. Training courses can be arranged with Berlin Heart, Inc.

---



---

The operator (i.e. the hospital using the system) is responsible for instruction and care of the patient. The patient must be instructed on safety risks and cautionary measures (moisture, temperature, electromagnetic fields, etc.).

---

---

The operator is also responsible for adherence to the prescribed maintenance and service intervals (see section 2.8: Battery replacement and disposal, page 23 and Tab. 2-1, page 23).

---

---

A replacement Ikus and replacement equipment must always be available in the hospital.

---

---

If any of the components are damaged or if faults occur, inform Berlin Heart GmbH/ Berlin Heart, Inc. service department immediately. Do not use damaged components.

---

---

Only operate the Ikus with the components specified in this document. Never operate the Ikus with multiple-socket mains adapters or mains extension cables.

---

## 2 General Information

### 2.1 Device description

EXCOR is an extracorporeal, pneumatically driven ventricular assist device. It is designed to support the right and/or left ventricle when the native heart is unable to maintain normal blood flows and pressures even with help of drug therapy and intra-aortic balloon counterpulsation. The device is designed for mid to long term mechanical support.

The EXCOR consists of 1 or 2 extracorporeal, pneumatically driven blood pumps and cannulae which connect the blood pump(s) to the atrium or ventricle and to the great arteries. The *Ikus* provides alternating air pressure to the blood pumps through driving tubes.

The blood pump is divided into an air chamber and a blood chamber by a multi-layer flexible polyurethane membrane. The alternating air pressure provided by the *Ikus* moves the membrane, thus filling and emptying the blood pump. Both the blood chamber and the polyurethane connectors are transparent to allow for visual detection of deposits and for monitoring the filling and emptying of the blood pump.

Valves (three-leaflet polyurethane valves) are located at the inlet and outlet positions of the blood pump connector stubs, thus ensuring the unidirectional blood flow.

Pulse rate, systolic drive pressure, diastolic suction pressure and the relative systolic duration can all be monitored and adjusted on the driving unit.

### 2.2 Indications for use

The EXCOR is intended to provide mechanical support as a bridge to cardiac transplantation for pediatric patients. Pediatric patients with severe isolated left ventricular or biventricular dysfunction who are candidates for cardiac transplant and require circulatory support may be treated using the EXCOR.

### 2.3 IDE Clinical Study Summary

See chapter 3: Summary of Clinical Studies, page 25.

### 2.4 Intended operation environment

*Ikus* is intended for use in a clinical setting. It can be used in any kind of hospital unit, e.g. OR, ICU, intermediate care unit or general care unit. It may be moved between clinical units using the built-in wheels, however in this case the patient must always be accompanied by a person trained in the use of the manual pump and emergency procedures. Thus, the patient shall be guaranteed care in case of an emergency.

Transporting the device during operation by any vehicles (e.g. ambulance, aircraft, etc.) is not allowed.

During movement of the device in operation within the clinic all electromagnetic compatibility precautions (EMC precautions) must be observed. See chapter 17: EMC tables, page 231. Otherwise there is a risk of electromagnetic disturbances and the fault-free operation of *Ikus* could not be guaranteed.

## 2.5 Contraindications

Patients unable to tolerate systemic anticoagulation therapy should not be implanted.

Magnetic Resonance Imaging (MRI) is contraindicated in patients after being implanted with the EXCOR.

Patients with aortic valve regurgitation that is more than moderate that cannot be repaired at the time of implantation should not be implanted with the EXCOR. If repair of the aortic valve regurgitation requires surgical closure of the aortic valve, the EXCOR should not be implanted. The EXCOR is not intended to be used as a total artificial heart and should not be used in this configuration.

## 2.6 Potential adverse events

Potential Adverse Events may include but are not limited to:

- Major Bleeding
- Cardiac Arrhythmia
- Pericardial Fluid Collection
- Hemolysis
- Hepatic Dysfunction
- Hypertension
- Infection
- Psychiatric Episode
- Neurological Dysfunction
- Renal Dysfunction
- Respiratory Failure
- Right Heart Failure
- Arterial Non-CNS thromboembolism
- Venous Thromboembolism Event
- Wound Dehiscence
- Device Malfunction

## 2.7 Storage and durability



---

The expiration date of each EXCOR product is found on the product labels located on both the outer and inner packaging. The pumps, cannulae and accessories must not be used after the expiration date and even not be re-sterilized. Otherwise there is a risk of patient infection.

---

---

An EXCOR blood pump may not be used on a patient for more than 1 year. After this it shall be replaced with new products.

---

**IMPORTANT:** EXCOR must be stored at room temperature and be protected against extreme temperature fluctuations and moisture. Otherwise there is a risk of functional limitation and/or damage to the Ikus.

**IMPORTANT:** If the Ikus is not in use, run it once a month for 24 hours in order to ensure that all batteries are adequately charged. Refer to section 6.5.1: Routine start-test when not in operation, page 83. Otherwise there is a risk that the Ikus no longer functions correctly.



## 2.8 Battery replacement and disposal



Only Berlin Heart GmbH/ Berlin Heart, Inc. service staff or persons authorized by the Berlin Heart GmbH service department may replace the batteries and dispose of them in accordance with the respective regulations.

## 2.9 Manufacturer's warranty

According to the General Terms and Conditions of Berlin Heart GmbH the warranty is valid for 1 year.

All warranties apply only under the prescribed conditions of storage of the system, use in accordance with the instructions (intended use) and when the packaging is intact. This applies, in particular, to all sterile packaging and to the aluminum-coated outer packaging of the blood pump(s).

The warranty is no longer valid, if the Ikus has been opened or serviced by persons who are not members of the Berlin Heart GmbH/ Berlin Heart, Inc. service staff and/ or who have not been authorized by the Berlin Heart GmbH service department to do so.

If an ambient temperature of +30°C is continuously exceeded during ongoing operation, the maintenance interval will be reduced.

Components	Product life (in sterile products starting from implantation)	Maintenance interval	Expiration date	Warranty
<b>unsterile</b>				
Ikus	max. 8 years	6 months or 2000 operating hours	x	1 year
Battery	exchange as needed	6 months or 2000 operating hours	x	6 months
Manual pump	max. 6 years	yearly	x	1 year
<b>sterile</b>				
Driving tube	1 year (single- use product)	x	3 years	1 year
Blood pumps	1 year (single- use product)	x	3 years	1 year

**Tab. 2-1** Product life, maintenance interval, expiration date, warranty

<b>Components</b>	<b>Product life (in sterile products starting from implantation)</b>	<b>Maintenance interval</b>	<b>Expiration date</b>	<b>Warranty</b>
Cannulae	no limitation (single-use product)	x	3 years	1 year
Accessories	single-use product	x	3 years	first use

**Tab. 2-1** Product life, maintenance interval, expiration date, warranty

Please dispose components according to local regulations and site policies.

## 3 Summary of Clinical Studies

### 3.1 Indications for use

EXCOR® Pediatric Ventricular Assist Device (referred to as EXCOR) is intended to provide mechanical circulatory support as a bridge to cardiac transplantation for pediatric patients. Pediatric candidates with severe isolated left ventricular or biventricular dysfunction who are candidates for cardiac transplant and require circulatory support may be treated using the EXCOR.

### 3.2 Contraindications

Patients unable to tolerate systemic anticoagulation therapy should not be implanted. Magnetic Resonance Imaging (MRI) is contraindicated in patients after being implanted with the EXCOR.

### 3.3 Alternative Practices or Procedures

FDA approved therapies include the DeBakey Child device for left ventricular support for body surface area  $> 0.7 \text{ m}^2$  and  $< 1.5 \text{ m}^2$ . EXCOR is the only ventricular assist device approved for univentricular and biventricular support in children from 3-60 kg.

### 3.4 Marketing History

EXCOR was approved to apply the CE Mark in 1996. Since that authorization, EXCOR has been distributed to the following countries: Germany, Austria, Belgium, Bulgaria, Estonia, Switzerland, Denmark, Spain, Finland, France, Great Britain, Greece, Hungary, Italy, Lithuania, Netherlands, Poland, Portugal, Romania, Sweden, Slovakia, Turkey, Argentina, Australia, Azerbaijan, Brazil, Canada, Chile, Taiwan, China, Hong Kong, Israel, Iran, New Zealand, Serbia, Russia, Saudi Arabia, and South Africa. The EXCOR has not been removed from the market in any country.

### 3.5 Potential Adverse Effects

Serious adverse events (SAEs) for all primary cohort patients were reported in the primary study analysis for events per patient-day. The total time on device for Cohort 1 (BSA  $< 0.7 \text{ m}^2$ ) subjects of 1411 days yielded a rate of 0.068 SAEs per patient-day. The total time on device for Cohort 2 (BSA  $> 0.7$  to  $< 1.5 \text{ m}^2$ ) subjects was 1376 days yielded a rate of 0.079 SAEs per patient-day.

The following table details each SAE with the number of events experienced and the number and percent of subjects experiencing each SAE. Some of the SAEs have subcategories (see indented descriptions) which provide additional detail regarding the type of SAE.

Rates for subjects enrolled in the Cohorts 1 CAP (Continued Access Protocol which allowed continued access to the device following the conclusion of enrollment in the primary cohorts) and Compassionate/ Emergency Use Cohorts 3A and 3B are included to support the assessment of reasonable assurance of safety as specified in the IDE Investigational Plan.

Serious Adverse Event Summary per Cohort

EVENT	COHORT										
	1 Total	Per Subject (% of 24)	1 CAP Total	Per Subject (% of 20)	3A Total	Per Subject (% of 35)	2 Total	Per Subject (% of 24)	3B Total	Per Subject (% of 6)	
Major Bleeding	15	10 (41.7%)	12	7 (35.0%)	25	18 (51.4%)	22	12 (50.0%)	3	3 (50.0%)	
Cardiac Arrhythmia	1	1 (4.2%)	2	2 (10.0%)	3	3 (8.6%)	6	4 (16.7%)	2	1 (16.7%)	
Sustained VT	1	1 (4.2%)	0	0 (0.0%)	2	2 (5.7%)	2	2 (8.3%)	2	1 (16.7%)	
Sustained SVT	0	0 (0.0%)	2	2 (10.0%)	1	1 (2.9%)	4	3 (12.5%)	0	0 (0.0%)	
Pericardial Fluid Collection	3	3 (12.5%)	5	5 (25.0%)	4	4 (11.4%)	4	3 (12.5%)	1	1 (16.7%)	
With Tamponade	1	1 (4.2%)	3	3 (15.0%)	2	2 (5.7%)	2	2 (8.3%)	0	0 (0.0%)	
Without Tamponade	2	2 (8.3%)	2	2 (10.0%)	2	2 (5.7%)	2	2 (8.3%)	1	1 (16.7%)	
Hemolysis	1	1 (4.2%)	1	1 (5.0%)	1	1 (2.9%)	1	1 (4.2%)	1	1 (16.7%)	
Hemolysis-Early	0	0 (0.0%)	0	0 (0.0%)	0	0 (0.0%)	0	0 (0.0%)	1	1 (16.7%)	
Hemolysis-Late	1	1 (4.2%)	1	1 (5.0%)	1	1 (2.9%)	1	1 (4.2%)	0	0 (0.0%)	
Hepatic Dysfunction	1	1 (4.2%)	0	0 (0.0%)	6	5 (14.3%)	1	1 (4.2%)	3	2 (33.3%)	
Hypertension	12	12 (50.0%)	15	13 (65.0%)	9	9 (25.7%)	8	8 (33.3%)	1	1 (16.7%)	
Major Infection	35	15 (62.5%)	15	7 (35.0%)	39	16 (45.7%)	24	12 (50.0%)	8	4 (66.7%)	
Infection-Localized Non-Device	25	12 (50.0%)	10	6 (30.0%)	20	11 (31.4%)	18	10 (41.7%)	7	3 (50.0%)	
Infection-Percutaneous Site or Pocket	4	4 (16.7%)	1	1 (5.0%)	0	0 (0.0%)	0	0 (0.0%)	0	0 (0.0%)	
Infection-Sepsis	6	5 (20.8%)	4	2 (10.0%)	19	9 (25.7%)	6	6 (25.0%)	1	1 (16.7%)	
Psychiatric Episode	0	0 (0.0%)	0	0 (0.0%)	0	0 (0.0%)	1	1 (4.2%)	0	0 (0.0%)	

Tab. 3-1 Serious adverse event summary per cohort

Serious Adverse Event Summary per Cohort, continued

EVENT	COHORT										
	1 Total	Per Subject (% of 24)	1 CAP Total	Per Subject (% of 20)	3A Total	Per Subject (% of 35)	2 Total	Per Subject (% of 24)	3B Total	Per Subject (% of 6)	
Neurological Dysfunction	8	7 (29.2%)	6	5 (25.0%)	6	6 (17.1%)	9	7 (29.2%)	4	3 (50.0%)	
TIA	0	0 (0.0%)	1	1 (5.0%)	0	0 (0.0%)	0	0 (0.0%)	1	1 (16.7%)	
Ischemic CVA	8	7 (29.2%)	5	5 (25.0%)	4	4 (11.4%)	7	7 (29.2%)	3	3 (50.0%)	
Hemorrhagic CVA	0	0 (0.0%)	0	0 (0.0%)	2	2 (5.7%)	2	2 (8.3%)	0	0 (0.0%)	
Renal Dysfunction	3	2 (8.3%)	0	0 (0.0%)	7	7 (20.0%)	4	3 (12.5%)	2	1 (16.7%)	
Acute	3	2 (8.3%)	0	0 (0.0%)	7	7 (20.0%)	2	2 (8.3%)	2	1 (16.7%)	
Chronic	0	0 (0.0%)	0	0 (0.0%)	0	0 (0.0%)	2	2 (8.3%)	0	0 (0.0%)	
Respiratory Failure	3	3 (12.5%)	8	8 (40.0%)	6	5 (14.3%)	9	6 (25.0%)	6	5 (83.3%)	
Right Heart Failure	2	2 (8.3%)	2	2 (10.0%)	8	7 (20.0%)	3	3 (12.5%)	1	1 (16.7%)	
Arterial Non-CNS Thromboembolism	1	1 (4.2%)	1	1 (5.0%)	2	2 (5.7%)	0	0 (0.0%)	0	0 (0.0%)	
Venous Thromboembolism Event	1	1 (4.2%)	1	1 (5.0%)	0	0 (0.0%)	0	0 (0.0%)	0	0 (0.0%)	
Wound Dehiscence	0	0 (0.0%)	0	0 (0.0%)	1	1 (2.9%)	0	0 (0.0%)	0	0 (0.0%)	
Other	10	6 (25.0%)	6	5 (25.0%)	17	12 (34.3%)	15	6 (25.0%)	7	4 (66.7%)	
Other Ischemic w/o symptoms	0	0 (0.0%)	0	0 (0.0%)	1	1 (2.9%)	0	0 (0.0%)	0	0 (0.0%)	
Other Covert Stroke	0	0 (0.0%)	0	0 (0.0%)	0	0 (0.0%)	0	0 (0.0%)	1	1 (16.7%)	

Tab. 3-2 Serious adverse event summary per cohort (table continued)

The rates of SAEs per patient-day were calculated separated by whether the subjects were supported with ECMO pre-implant and are summarized in the following table. In Cohort 1, those supported with ECMO pre-implant had twice as many events per patient-day of support. For Cohort 2, those supported with ECMO pre-implant had 1.5 times as many events per patient-day of support.

**Serious Adverse Events per Patient-day by pre-implant ECMO**

Group	ECMO Pre-Implant	# Events	Total Time on Support (Days)	Rates Success Criterion <0.25	
				Events per Patient-Day	Upper bound of CI
Cohort 1	Yes	38	345	0.110	0.151
	No	58	1066	0.054	0.070
Cohort 2	Yes	43	450	0.096	0.129
	No	64	926	0.069	0.088

**Tab. 3-3** Serious adverse events per patient-day pre-implant ECMO

### 3.6 IDE Clinical Study

#### 3.6.1 IDE Clinical Study Summary

Berlin Heart Inc. conducted a prospective, multi-center, single arm study to assess the safety and probable benefit of the EXCOR.

The purpose of the study was to determine whether use of the EXCOR for bridge-to-transplantation is associated with reasonable assurance of safety and probable benefit such that the EXCOR merits approval by the Food and Drug Administration (FDA) under a Humanitarian Device Exemption (HDE).

#### 3.6.2 Study Cohorts

The primary study population of 48 subjects aged 0-16 years consisted of 24 subjects with a body surface area (BSA) < 0.7 m<sup>2</sup> (Cohort 1) and 24 subjects with a body surface area (BSA) <sup>3</sup> 0.7 m<sup>2</sup> to < 1.5 m<sup>2</sup> (Cohort 2).

A third cohort of subjects was enrolled under Compassionate / Emergency Use regulations and is classified as Cohort 3. These subjects followed the study protocol unless otherwise noted within the approval documentation for the subject. This cohort is further divided into groups based on the subject’s BSA similar to Cohorts 1 and 2 and is labeled Cohort 3A if the subject’s BSA is < 0.7 m<sup>2</sup> and Cohort 3B if the BSA is <sup>3</sup> 0.7 m<sup>2</sup> and <1.5 m<sup>2</sup>.

For the primary effectiveness endpoint, the protocol prescribed an ECMO historical control group. The historical ECMO control group was compiled from the Extracorporeal Life Support Organization (ELSO) registry, the most extensive registry of patients treated with ECMO in North America. The database was filtered to best match the EXCOR IDE study population. Patients included for comparison to the EXCOR cohorts included patients from both genders, age 0-16 years, with weight greater than 3 kg, cardiac only ECMO support, support initiation from 2000 onward

who met critical eligibility criteria. The dataset for the ELSO registry included baseline and outcomes data comparable to the EXCOR dataset. The control group was then created by matching the EXCOR subjects to the patients in the subset using a propensity score analysis (PSA).

### 3.6.3 Inclusion/Exclusion Criteria

Subjects of both genders who satisfy all inclusion and exclusion criteria were eligible for entrance into the primary cohorts of the clinical study.

#### Inclusion Criteria

1. Severe NYHA Functional Class IV (or Ross Functional Class IV for subjects  $\leq 6$  years) heart failure refractory to optimal medical therapy, and has met at least one of the following criteria:
  - a. INTERMACS™ profile status 1 or 1A, i.e. critical cardiogenic shock (low BP unresponsive to support, compromised end organ perfusion, < 24 hour survival expected without mechanical support; may be due to VT/VF (1A)
  - b. INTERMACS profile status 2 or 2A (i.e. progressive decline): not in imminent danger, but worsening despite optimal inotropic therapy; may be due to VT/VF (2A) AND at least one of the following criteria:
    - a. Decline in renal function as defined by a 50 % reduction in estimated GFR despite optimization of subject volume status
    - b. Decline in nutritional status as defined by a sustained ( $\geq 7$  days) inability to tolerate an enteral nutritional intake sufficient to provide at least 75 % of the prescribed caloric needs for the subject, or signs of nutritional compromise (cachexia, nutritional weight loss) despite appropriate intervention
    - c. Decline in mobility/ambulation as defined by sustained bed confinement ( $\geq 7$  days without prospect for improvement) attributable to heart failure symptoms or its treatment (e.g. intubation for pulmonary edema)
  - c. Support with extra-corporeal membrane oxygenation (ECMO) or other mechanical circulatory support device OR
  - d. Unable to separate from cardiopulmonary bypass (must be listed for heart transplantation at time of transfer to the operating room)
2. Listed (UNOS status 1A or equivalent) for cardiac transplantation
3. Two-ventricle circulation, including cardiomyopathy, repaired structural heart disease (e.g. ALCAPA, aortic stenosis) or acquired heart disease (e.g. myocarditis, Kawasaki disease)
4. Age 0 to 16 years; corrected gestational (CGA) at least 37 weeks
5. Weight  $\geq 3$  kg and  $\leq 60$  kg
6. Legal guardian (and subject if age-appropriate) understands the nature of the procedure, are willing to comply with associated follow-up evaluations, and provide written informed consent and assent prior to the procedure

### Exclusion Criteria

1. Support on ECMO for  $\geq 10$  days
2. Cardiopulmonary resuscitation (CPR) duration  $\geq 30$  minutes within 48 hours prior to device implantation
3. Body weight  $< 3.0$  kg or BSA  $> 1.5$  m<sup>2</sup>
4. Presence of mechanical aortic valve
5. Unfavorable or technically-challenging cardiac anatomy including single ventricle lesions, complex heterotaxy, and restrictive cardiomyopathy
6. Evidence of intrinsic hepatic disease as defined by a total bilirubin level or AST/ALT greater than five times the upper limit of normal for age, except in association with acute heart failure as determined by the principal investigator
7. Evidence of intrinsic renal disease as defined by a serum creatinine greater than 3 times the upper limit of normal for age, except in association with acute heart failure as determined by the principal investigator
8. Hemodialysis or peritoneal dialysis (not including dialysis or Continuous Venovenous Hemofiltration (CVVH) for volume removal
9. Evidence of intrinsic pulmonary disease (e.g. chronic lung disease, RDS) as defined by need for chronic mechanical ventilation, except in association with acute heart failure as determined by the principal investigator
10. Moderate or severe aortic and/or pulmonic valve insufficiency considered technically challenging to repair at the time of the device implantation as determined by the principal investigator
11. Apical VSD or other hemodynamically-significant lesion considered technically challenging to repair at the time of device implantation as determined by the principal investigator
12. Documented heparin induced thrombocytopenia (HIT) or idiopathic thrombocytopenia purpura (ITP) or other contraindication to anticoagulant/antiplatelet therapy
13. Documented coagulopathy (e.g. Factor VIII deficiency, disseminated intravascular coagulation) or thrombophilic disorder (e.g. Factor V Leiden mutation)
14. Hematologic disorder causing fragility of blood cells or hemolysis (e.g. sickle cell disease)
15. Active infection within 48 hours of implant demonstrated by:
  - a. Positive blood culture OR
  - b. Temperature  $>38$  degrees C and WBC  $>15,000$ / ml
16. Documented human immunodeficiency virus (HIV) infection or acquired immunodeficiency syndrome (AIDS)
17. Evidence of recent or life-limiting malignant disease
18. Stroke within past 30 days prior to enrollment, or congenital CNS malformation syndrome associated with increased risk of bleeding (e.g. arteriovenous malformation, moya moya)
19. Psychiatric or behavioral disease (e.g. antisocial disorder) with a high likelihood for non-compliance
20. Currently participating in another investigational device or drug trial and has not completed the required follow-up period for that study
21. Subject is pregnant or nursing

### 3.6.4 Study Enrollment

The following table summarizes the complete enrollment (including the subjects enrolled at non IDE sites) by subject's body size. As of the data cutoff for the final HDE report (February 2011 report with January 17, 2011 data cutoff), there were 151



smaller sized subjects ( $BSA < 0.7\text{m}^2$ ) enrolled and 53 larger sized subjects ( $BSA \geq 0.7$  to  $< 1.5\text{m}^2$ ) enrolled.

### Subject Enrollment

Cohort	IDE Site Implants	Non-IDE Site Implants	Total
<b>BSA &lt; 0.7 m<sup>2</sup></b>			
Cohort 1	24	<i>n/a</i>	24
Cohort 1 CAP	20	<i>n/a</i>	20
Cohort 3A	35	72	107
<i>Subtotal</i>	79	72	151
<b>BSA <math>\geq 0.7\text{ m}^2</math> to <math>&lt; 1.5\text{ m}^2</math></b>			
Cohort 2	24	<i>n/a</i>	24
Cohort 3B	6	23	29
<i>Subtotal</i>	30	23	53
<b>TOTAL</b>	<b>109</b>	<b>95</b>	<b>204</b>

**Tab. 3-4** Subject enrollment

*Note: Enrollment in Cohorts 1 CAP, 3A, 3B (IDE and non-IDE) are supportive data and are included only in the safety summary tables.*

**Study Enrollment and Outcome**

Total Enrollment June 21, 2007 -- December 1, 2010 n=204						
BSA < 0.7m <sup>2</sup> n=151  Transplant n=88 Weaned n=10 Death n=45 On device n= 8				BSA ≥ 0.7 m <sup>2</sup> - < 1.5 m <sup>2</sup> n=53  Transplant n=42 Weaned n= 2 Death n= 6 On device n= 3		
Cohort 1  n=24	Cohort 1 CAP  n=20	Cohort 3A IDE Sites  n=35	Cohort 3A Non-IDE Sites  n=72	Cohort 2  n=24	Cohort 3B IDE Sites  n=6	Cohort 3B Non-IDE Sites  n=23
TX n=21 Weaned n=1  Death n=2  On Device n=0	TX n=16 Weaned n=0  Death n=1  On Device n=3	TX n=20 Weaned n=3  Death n=10  On Device n=2	TX n=31 Weaned n=6  Death n=32  On Device n=3	TX n=21 Weaned n=1  Death n=2  On Device n=0	TX n= 4 Weaned n=1  Death n=1  On Device n=0	TX n=17 Weaned n=0  Death n=3  On Device n=3

**Fig. 3-1** Study enrollment and outcome

*Enrollment in Cohorts 1 CAP, 3A, 3B (IDE and non-IDE) are supportive data and are only included in the safety summary tables.*

**3.6.5 Subject Demographics**

The following table summarizes the demographic data for Cohorts 1 and 2. Males comprised the majority of the subjects in Cohort 2 (54%) and half (50%) of Cohort 1. The smaller group of subjects ranged in age from 2.6 to 45.6 months while the larger group ranged in age from 51 to 192 months (or 4.2 to 16 years). The weight range for Cohort 1 was 3.6 to 13.6 kilograms with a BSA range of 0.23 to 0.62 m<sup>2</sup> and the weight range for Cohort 2 was 16.0 to 58.1 kilograms with a BSA range of 0.71 to 1.66 m<sup>2</sup>.

The most predominant cardiac diagnosis for Cohort 1 was dilated cardiomyopathy (79.2%) and the majority of this group, 54.2%, presented with progressive decline. The most predominant cardiac diagnosis for Cohort 2 was also dilated cardiomyopathy (70.8%) and most (54.2%) were listed as in critical cardiogenic shock.

**Demographic Data Summary**

<b>Variable</b>	<b>Category</b>	<b>Cohort 1 n=24</b>	<b>Cohort 2 n=24</b>
Gender	Female	12 (50.0%)	11 (45.8%)
	Male	12 (50.0%)	13 (54.2%)
Age (months)	Mean $\pm$ Std (N)	15.4 $\pm$ 12.4 (24)	113.2 $\pm$ 37.6 (24)
	Median	11.7	111.2
	Min – Max	2.6 - 45.6	50.8 - 191.8
BSA (m <sup>2</sup> )	Mean $\pm$ Std (N)	0.43 $\pm$ 0.10 (24)	1.09 $\pm$ 0.29 (24)
	Median	0.44	1.08
	Min – Max	0.23 - 0.62	0.71 - 1.66
Weight (kg)	Mean $\pm$ Std (N)	9.1 $\pm$ 2.7 (24)	32.2 $\pm$ 12.5 (24)
	Median	9.2	30.7
	Min – Max	3.6 - 13.6	16.0 – 58.1
Race	African-American	7 (29.2%)	6 (25.0%)
	American Indian/Alaska Native	1 ( 4.2%)	0 ( 0.0%)
	Asian	0 ( 0.0%)	1 ( 4.2%)
	Hawaiian/other Pacific Islander	0 ( 0.0%)	1 ( 4.2%)
	White	13 (54.2%)	15 (62.5%)
	Other/none of the above	3 (12.5%)	1 ( 4.2%)
Ethnicity: Hispanic or Latino	Yes	7 (29.2%)	1 ( 4.2%)

**Tab. 3-5** Demographic data summary (a)

**Demographic Data Summary, *continued***

Variable	Category	Cohort 1	Cohort 2
		n=24	n=24
Patient Profile/Status	1 Critical Cardiogenic Shock	11 (45.8%)	13 (54.2%)
	2 Progressive decline	13 (54.2%)	11 (45.8%)
	3 Stable but Inotrope dependent	0 ( 0.0%)	0 ( 0.0%)
Modifier A Arrhythmia (# Yes)		4 (16.7%)	4 (16.7%)
Primary Cardiac Diagnosis	Congenital Heart Disease	3 (12.5%)	6 (25.0%)
	Dilated Myopathy	19 (79.2%)	17 (70.8%)
	Hypertrophic cardiomyopathy	1 ( 4.2%)	0 ( 0.0%)
	Restrictive Myopathy	1 ( 4.2%)	1 ( 4.2%)
Secondary Cardiac Diagnosis (multiple Choices)	Congenital Heart Disease	2 ( 8.3%)	3 (12.5%)
	Coronary Artery Disease	0 ( 0.0%)	2 ( 8.3%)
	Dilated Myopathy: Familial	1 ( 4.2%)	0 ( 0.0%)
	Dilated Myopathy: Idiopathic	0 ( 0.0%)	2 ( 8.3%)
	Dilated Myopathy: Ischemic	0 ( 0.0%)	1 ( 4.2%)
	Dilated Myopathy: Myocarditis	0 ( 0.0%)	2 ( 8.3%)
	Dilated Myopathy: Viral	1 ( 4.2%)	0 ( 0.0%)
	Dilated Myopathy: Other	1 ( 4.2%)	2 ( 8.3%)
	Restrict Myopathy: Secondary to Radiation/Chemo	0 ( 0.0%)	1 ( 4.2%)
	Valvular Heart Disease	0 ( 0.0%)	1 ( 4.2%)
	CHD/Dilated Myopathy Familial	1 ( 4.2%)	0 ( 0.0%)
	None	18 (75.0%)	10 (41.7%)
	Heart Rate	Mean ± Std (N)	126.3 ± 25.5 (24)
Min – Max		91.0 - 175.0	85.0 - 168.0
Systolic Blood Pressure	Mean ± Std (N)	85.3 ± 16.0 (24)	95.2 ± 13.5 (24)
	Min – Max	45.0 - 110.0	60.0 - 112.0
Diastolic Blood Pressure	Mean ± Std (N)	56.0 ± 14.1 (24)	65.9 ± 14.8 (24)
	Min – Max	38.0 - 89.0	46.0 - 100.0
Previous Cardiac operations (# Yes)		5 (20.8%)	8 (33.3%)

**Tab. 3-6** Demographic data summary (b)

Pre-implant support for the subjects is detailed in the following table. ECMO support was used pre-implant for 25% of Cohort 1 subjects and 33.3% of Cohort 2 subjects.

**Pre-Implant Support**

Variable	Category	Cohort 1	Cohort 2
		n=24	n=24
Prior support within 48 hours	No support	0 ( 0.0%)	0 ( 0.0%)
	Ventilator	20 (83.3%)	12 (50.0%)
	ECMO	6 (25.0%)	8 (33.3%)
	Ultrafiltration	3 (12.5%)	1 ( 4.2%)
	VAD	2 ( 8.3%)	0 ( 0.0%)
	Dialysis	0 ( 0.0%)	0 ( 0.0%)
	Feeding Tube	10 (41.7%)	7 (29.2%)
	IABP	0 ( 0.0%)	0 ( 0.0%)
	Inotropes	22 (91.7%)	21 (87.5%)

Tab. 3-7 Pre-implant support

**3.6.6 Results****3.6.6.1 Probable Benefit**

Efficacy for the IDE trial was assessed by comparing survival (defined by the interval of time from initiation of mechanical support as a bridge to transplant or recovery) to the historical ECMO control. Subjects who were transplanted were censored at the time of explant. Subjects who were explanted due to recovery of their ventricular function and survived to 30 days or discharged with acceptable neurologic status were censored at the time of explant. Subjects who were explanted due to recovery of their ventricular function and died within 30 days or discharge (whichever was longer) were counted as a failure with time to failure being the explant date.

For the 2 primary cohorts, the rate of successfully bridging the subjects to transplant was 87.5% for Cohort 1 (21/24) and 91.7% for Cohort 2 (22/24) or 89.6% overall (43/48). The following table summarizes the survival to transplant/successful recovery for each primary Cohort ITT and PP as well as their matched ECMO control groups.

Three (3) of the Cohort 1 subjects (12.5%) failed (2 deaths and 1 weaned subject with unacceptable neurological outcome at 30 days post-explantation) compared to 12 of the 48 (25%) patients in the matched ECMO control group. The 3 subjects from Cohort 1 who died or were considered failures were all supported with ECMO at the time of implant. The failures occurred at day 0 (death), day 38 (death) and day 146 (weaned-failure).

The control group for Cohort 1 was on ECMO for a median of 4.9 days and a maximum of 20.5 days compared to the primary cohort subjects who were supported a median of 27.5 days and maximum of 174 days. Seventeen (17) of the 24 (71%) Cohort 1 subjects were supported longer than the entire ECMO control group (i.e. longer than 20.5 days).

Two of the Cohort 2 subjects (8.3%) failed compared to 16 of the 48 (33.3%) patients in the matched ECMO control group. One of the subjects who died in Cohort 2 was

supported with ECMO at the time of implant. The deaths occurred at day 19 and day 144.

The control group for Cohort 2 was on ECMO for a median of 4.7 days and a maximum of 27.5 days compared to the primary cohort subjects who were supported a median of 42.5 days and a maximum of 192 days. Seventeen(17) of the 24 (71%) subjects in Cohort 2 were supported longer than the entire ECMO control group (i.e. longer than 27.5 days).

<b>Primary Efficacy Study and Control Groups</b>							
<b>Group</b>	<b>Total</b>	<b>Max Time on Device (days)</b>	<b># Successes</b>	<b># Failures</b>	<b>Survival Time</b>		
					<b>30 days</b>	<b>60 days</b>	<b>90 days</b>
Cohort 1 ITT	24	174	21 (87.5%)	3 (12.5%)	95.8%	87.1%	87.1%
Cohort 1 Per-Protocol	22	174	19 (86.4%)	3 (13.6%)	95.5%	86.8%	86.8%
ECMO Control Group	48	20.5	36 (75.0%)	12 (25.0%)	NA	NA	NA
Cohort 2 ITT	24	192	22 (91.7%)	2 (8.3%)	94.7%	94.7%	94.7%
Cohort 2 Per-Protocol	22	144	20 (90.9%)	2 (9.1%)	94.1%	94.1%	94.1%
ECMO Control Group	48	27.5	32 (66.7%)	16 (33.3%)	NA	NA	NA

**Tab. 3-8** Primary Efficacy Study and Control Groups

Comparison of the ITT groups to their respective matched ECMO control group survival rates were both statistically significant (log-rank p value <0.0001). Therefore, there is a significantly higher survival rate of Cohort 1 and 2 subjects as compared to their respective ECMO control group.

The following figures display the Kaplan-Meier curves for the endpoint of death/weaned with unacceptable outcome for both Cohort 1 ITT and Cohort 2 ITT and their respective ECMO control groups.

**Survival to Death/Weaned with Unacceptable Neurological Outcome:  
Cohort 1 versus ECMO**

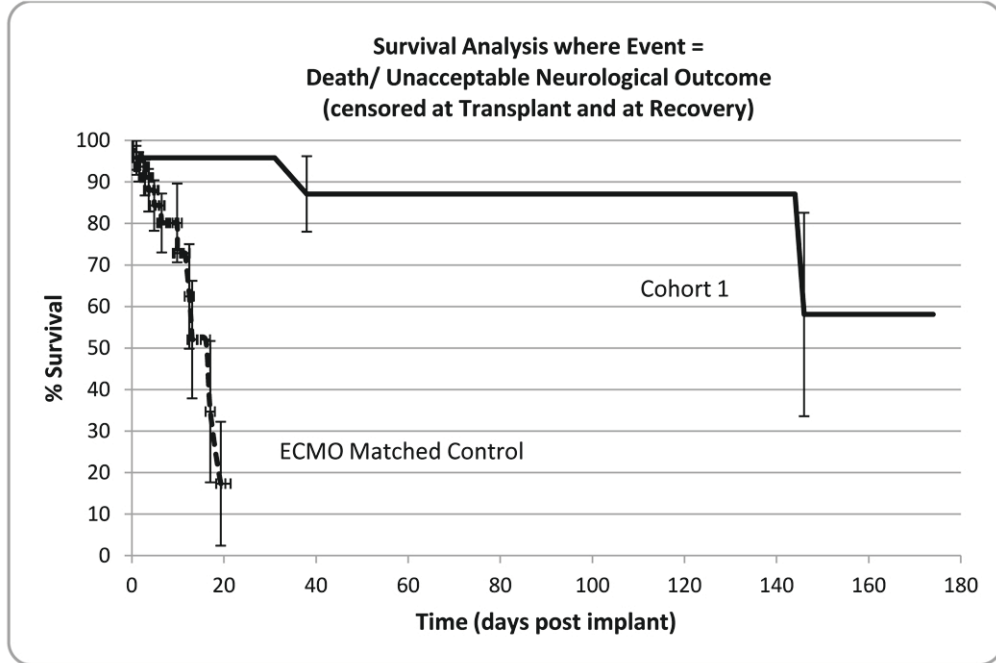

COHORT 1	Interval Ending (Days Post Implant)									
	0	1	7	14	30	45	60	90	120	150
# Left	24	21	21	20	12	10	9	6	5	1
Total # Failed	0	1	1	1	1	2	2	2	2	3
Survival	100%	95.8%	95.8%	95.8%	95.8%	87.1%	87.1%	87.1%	87.1%	58.1%
Std Error	0%	4.1%	4.1%	4.1%	4.1%	9.1%	9.1%	9.1%	9.1%	24.5%

ECMO CONTROL	Interval Ending (Days Post Implant)				
	0	1	7	14	30
# Left	48	46	16	4	0
Total # Failed	0	2	7	10	12
Survival	100%	95.8%	80.1%	52.0%	17.3%
Std Error	0%	2.9%	7.1%	14.2%	14.9%

Fig. 3-2 Cohort 1 Survival



**Survival to Death/Weaned with Unacceptable Neurological Outcome:  
Cohort 2 versus ECMO**

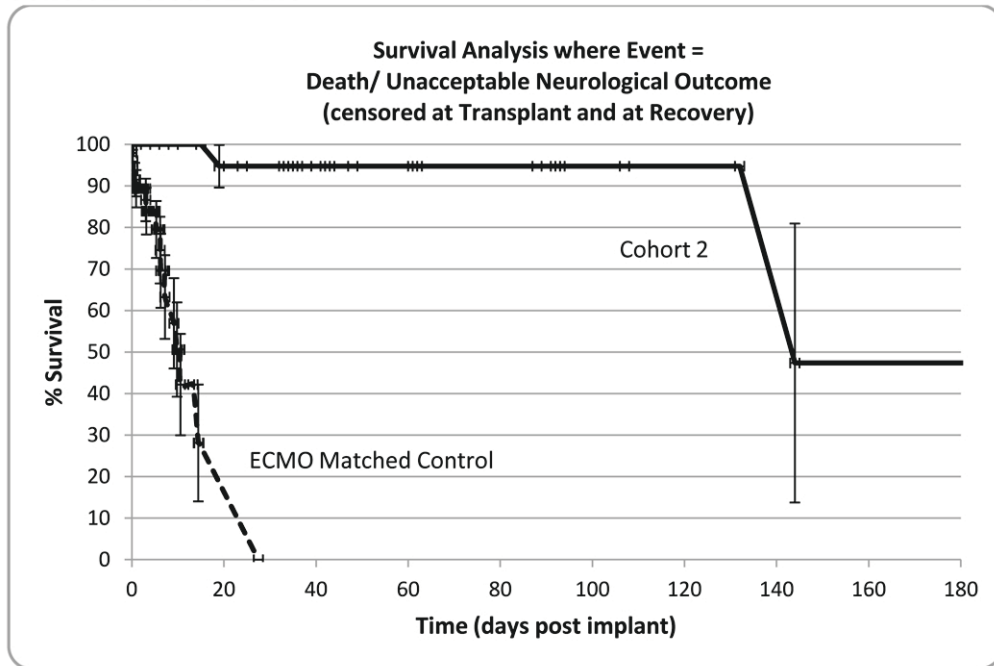

COHORT 2	Interval Ending (Days Post Implant)									
	0	1	7	14	30	45	60	90	120	150
# Left	24	23	21	20	17	11	9	6	3	1
Total # Failed	0	0	0	0	1	1	1	1	1	2
Survival	100%	100%	100%	100%	94.7%	94.7%	94.7%	94.7%	94.7%	47.4%
Std Error	0%	0%	0%	0%	5.1%	5.1%	5.1%	5.1%	5.1%	33.6%

ECMO CONTROL	Interval Ending (Days Post Implant)				
	0	1	7	14	30
# Left	48	41	12	3	0
Total # Failed	0	5	10	15	16
Survival	100%	89.4%	69.6%	42.2%	0%
Std Error	0%	4.5%	8.9%	12.2%	.

**Fig. 3-3** Cohort 2 Survival

Because the Kaplan-Meier analysis censors subjects at time of transplant, “Competing Outcomes” curves were constructed to show a more complete picture of the endpoints.

The following figure shows the “Competing Outcomes” for Cohort 1. The curves represent each of the outcomes and at any time point the sum of the proportions of outcomes equals 100%.

Of the 24 Cohort 1 subjects, 21 were transplanted between 1 to 174 days of support. The 2 deaths in this Cohort occurred at 0 and 38 days post implant. One subject was weaned after 146 days due to poor prognosis.

**Competing Outcomes – Cohort 1**

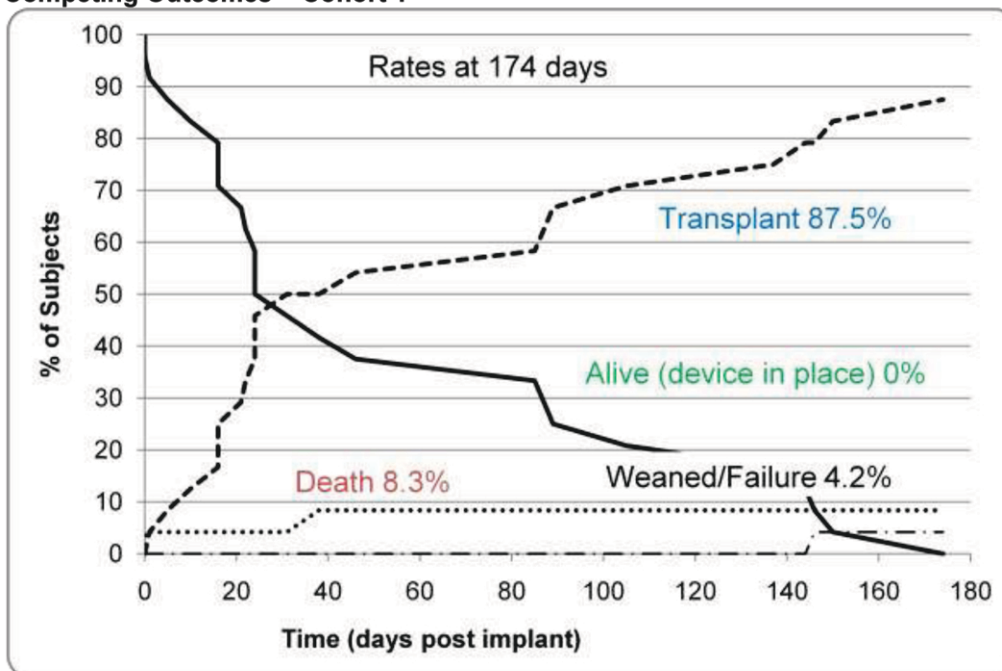

**Fig. 3-4** Cohort 1 Competing outcomes

The next figure shows the “Competing Outcomes” for the ECMO control group for Cohort 1. The longest support time was 20.5 days at which time 75% were weaned from ECMO for recovery or transplant.

**Competing Outcomes – ECMO Control group for Cohort 1**

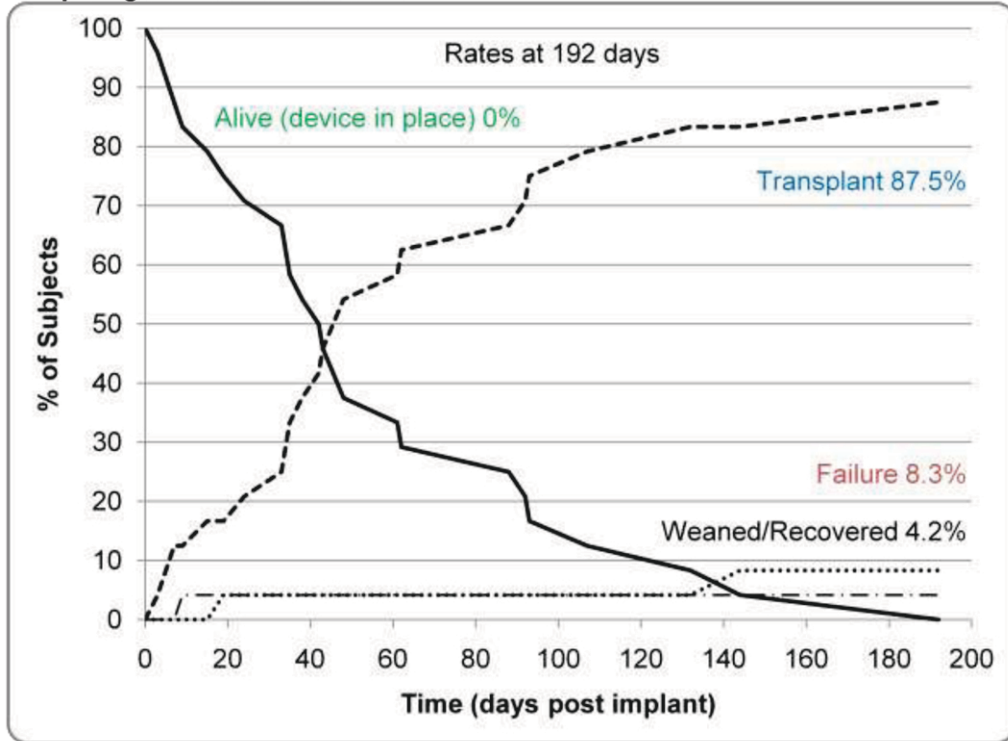

**Fig. 3-5** Cohort 1 control group competing outcomes

The following figure shows the “Competing Outcomes” for Cohort 2. Of the 24 Cohort 2 subjects, 21 were transplanted between 3 to 192 days of support. The 2 deaths in

this Cohort occurred at 19 and 144 days post implant. One subject was successfully weaned to recovery after 9 days.

#### Competing Outcomes – Cohort 2



**Fig. 3-6** Cohort 2 competing outcomes

The next figure shows the “Competing Outcomes” for the ECMO control group for Cohort 2. The longest support time was 27.5 days at which time 67% were weaned from ECMO for recovery or transplant.

**Competing Outcomes – ECMO Control group for Cohort 2**

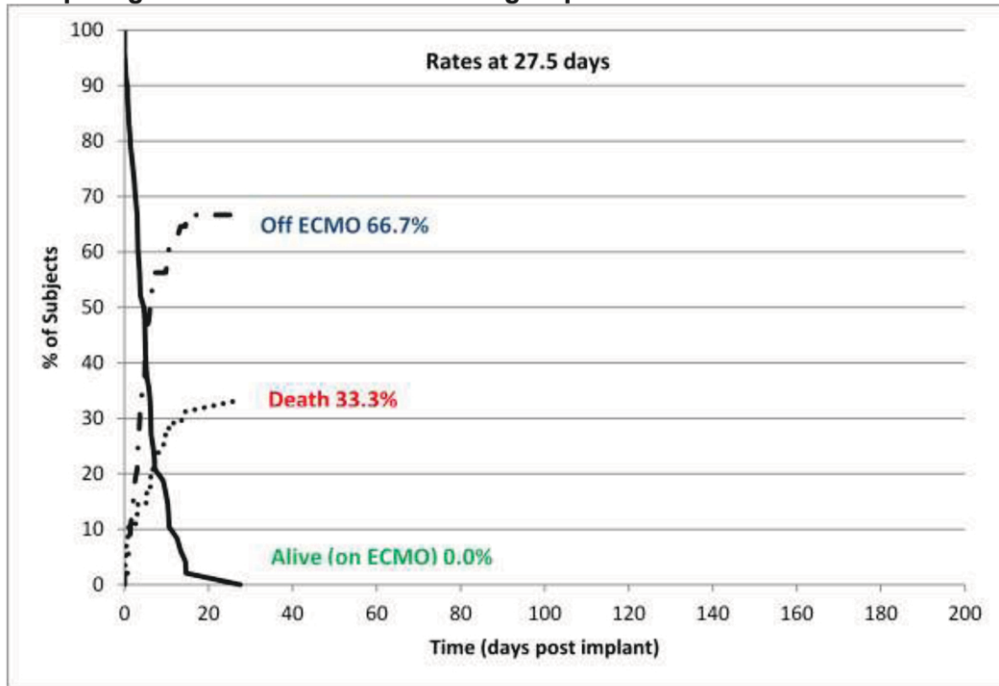

**Fig. 3-7** Cohort 2 Control Group Competing Outcomes

**a) Secondary Efficacy Results**

There were two secondary efficacy objectives of the study. The first was to summarize the days of transplant eligible support.

Only one subject was removed from the transplantation listing at any point during their support. The subject (in Cohort 2) was first listed on day 3 of support (10/03/09) and then was delisted from 01/15/10 to 02/22/10 due to a neurological event. The subject was successfully transplanted on 04/10/10. The summary statistics of time of eligible support are detailed in the following table.

**Days of Transplant Eligible Support**

Cohort	N	Median	Mean ± Std	Range
Cohort 1	24	27.5	58.8 ± 56.1	0 – 174
Cohort 2	24	42.5	55.6 ± 44.3	3 – 151

**Tab. 3-9** Days of transplant eligible support

The second objective was to show the ability to de-intensify concomitant hemodynamic support. At each visit, the subject’s status was recorded with the following choices: sedated, intubated, on ECMO, awake, ambulating or eating. The following table summarizes those choices pre-implant, and at 2 weeks and 1 month post-implant. A subject could have more than one status subcategory checked.

Prior to implant, 22 of the 24 Cohort 1 subjects (92%) and 16 of 24 Cohort 2 subjects (67%) were sedated and/or intubated and over 30% were supported by ECMO immediately prior to device implant.

In Cohort 1 there were 7 subjects (7/20=35%) who were sedated and intubated at 2 weeks with 1 sedated and awake (1/20=5%). The other 12 (12/20=60%) were awake with some of those also ambulating and eating.

In Cohort 2, 6 subjects (6/20=30%) were still sedated and intubated at 2 weeks with 1 awake and intubated (1/20=5%) and the remaining 13 awake (13/20=65%). At 1 month post, those numbers drop to only 3 of the Cohort 1 and 4 of the Cohort 2 subjects remaining sedated and intubated.

### Support Status at each Follow-up Visit

Time Point	Status (more than 1 could be checked)	Cohort 1 n=24	Cohort 2 n=24
<b>Pre-implant</b>  N=24 In each cohort	Sedated	21 (87.5%)	16 (66.7%)
	Intubated	21 (87.5%)	14 (58.3%)
	On ECMO/other	8 (33.3%)	9 (37.5%)
	Awake	3 (12.5%)	12 (50.0%)
	Ambulating	0 ( 0.0%)	5 (20.8%)
	Eating	0 ( 0.0%)	8 (33.3%)
<b>2 Weeks</b>  N=20 In each cohort	Sedated	8 (40.0%)	6 (30.0%)
	Intubated	7 (35.0%)	6 (30.0%)
	Awake	13 (65.0%)	14 (70.0%)
	Ambulating	3 (15.0%)	4 (20.0%)
	Eating	6 (30.0%)	12 (60.0%)
<b>1 Month</b>  N=12 Cohort 1 N=17 Cohort 2	Sedated	4 (33.3%)	5 (29.4%)
	Intubated	3 (25.0%)	5 (29.4%)
	Awake	9 (75.0%)	13 (76.5%)
	Ambulating	3 (25.0%)	8 (47.1%)
	Eating	4 (33.3%)	9 (52.9%)

Tab. 3-10 Support status at each follow-up visit

#### 3.6.6.2 Primary Safety

The total time on device of the Cohort 1 subjects was 1411 days. There were 96 serious adverse events (SAEs) for this cohort yielding a rate of **0.068 events per patient-day**. The 95% Poisson confidence interval was calculated as: [0.055, 0.083]. The total time on device for Cohort 2 was 1376 days. There were 109 SAEs for this cohort yielding a rate of **0.079 events per patient-day** with the confidence interval as [0.065, 0.096]. A summary of SAEs rates for each cohort is included in the first table of this clinical study section.

##### a) Infection Serious Adverse Events

Major Infection events were reported according to the Investigational Plan definition (which is the same as the INTERMACS definition). Any time an additional medication was added for treating a different organism a new SAE was reported (or adjudicated

as an event). The study design was intentionally broad with regard to setting a low threshold for calling an event an infection. Fever was defined at 38 degrees, WBC > 15,000, positive cultures from any source, or decision to start antibiotics with or without positive cultures were listed as an SAE and subsequently adjudicated. Each infection was counted as a separate event even when occurring concurrently in one patient, ensuring that the infection rate would not be under-reported.

In Cohort 1, 15 subjects had 35 total infectious events reported. In Cohort 1, a majority of subjects had pre-existing risks for infection including ventilation (83%), pre-implant ECMO support (33%), and previous cardiac surgery (21%).

In the larger subjects (Cohorts 2) there were fewer events (12 subjects with 24 events) which is as expected based on age and body size.

Outcomes of any of the subjects did not appear to be affected by infections as the deaths that occurred were not solely related to infection, even when one was present. These cases tended to have multi-factorial contributors such as stroke, end-organ failure, arrhythmias, or thromboembolism. All other subjects with a noted infectious SAE were transplanted or weaned. Infection had little impact on the transplant wait time since 99.3% of the total time the subjects were on support was considered transplant eligible time.

### **b) Major Bleeding Serious Adverse Events**

Major Bleeding was the third most frequently reported SAE in Cohort 1 (10 subjects with at least one event). All bleeding events for Cohort 1 occurred in subjects less than 2 years old. Five of the 10 subjects in Cohort 1 with bleeding events were younger than 9 months old. Young infants have some degree of ineffective erythropoiesis. Hemoglobin subsequently falls to a nadir at around 2–3 months of age due to decreased RBC production. Anemia in acute or critical illness may be exacerbated by numerous factors including blood loss (due to hemorrhage or sampling), reduced RBC production (due to nutritional deficits, inflammatory processes or low erythropoietin levels) and increased RBC turnover due to hemolysis.

Cohort 1 subjects had a pre-implant history of transfusion in 92% (22/24), history of ECMO or previous VAD in 33% (8/24), and 21% (5/24) of subjects had previous cardiac surgeries. These factors along with the strict Major Bleeding definition could have contributed to the percentage of events reported.

Major Bleeding was one of most prevalent events in Cohort 2 with 12 of 24 (50%) subjects experiencing a bleeding event.

### **c) Hypertension Serious Adverse Events**

Hypertension was reported per the protocol definition (consistent with the INTERMACS definition). An event was logged each time a subject's blood pressure reached the 95th percentile for age and was treated with an IV agent. Several hypertension events were reported in the early post-op periods. However, 75% (15/20) of the hypertension events were in Cohort 1 and 2 subjects who only received LVAD support. This is not surprising as it is common for patients supported only with left sided devices to require pharmacological support in order to optimize right ventricular function with agents that can cause hypertension, resulting in the concomitant need for agents to lower the blood pressure in the early post-operative period. Additionally, hypertension is one of the leading post operative cardiac surgical events for children, especially the younger children, possibly due to their reactive vasculature. In order to follow the event definition, hypertension events were reported when the values met the definition even if the subject was also on a pressor or in a period where the site was trying to optimize the overall hemodynamic status of the

subject in the early post-op period. There did not appear to be a correlation between Hypertension and Major Bleeding.

#### d) Neurological Dysfunction Serious Adverse Events

Four of the 48 (8.3%) Cohort 1 and 2 subjects experienced a neurological dysfunction with long term severe results (PSOM scores  $\geq 2$ ) and another 2 (4.2%) were withdrawn from support due to the neurological injury.

In Cohort 1, 7 of the 24 subjects experienced a neurological event. One subject experienced 2 ischemic events. Of the 7 subjects, 1 was withdrawn from support as a result of the neurological injury. Of the remaining 6 subjects, PSOM exams were performed post explant and 1 had no deficit (assessed 17 days post explant); 2 had mild deficits (23 and 221 days post explant), 1 had moderate deficit (82 days post) and 2 had severe deficits (PSOM score of 3 at 34 days post and score 4 at 54 days post).

In Cohort 2, 7 of the 24 subjects experienced a neurological event. Two of those subjects experienced both an ischemic and hemorrhagic event. Of the 7 subjects, 1 was withdrawn from support as a result of the neurological injury. Of the remaining 6 subjects, PSOM exams were performed post explant and 1 had no deficit (50 days post explant); 2 had mild deficits (27 and 49 days post explant), 1 had moderate deficit (357 days post) and 2 had severe deficits (PSOM scores of 10 at 29 and 38 days post).

This table summarizes the status information.

#### Summary of Neurological Event Status

Long term Result	Cohort 1 N=24	Cohort 2 N=24	Total N=48
No Deficit (PSOM 0.0)	1 ( 4.2%)	1 ( 4.2%)	2 ( 4.2%)
Mild (PSOM 0.5-1.0)	2 ( 8.3%)	2 ( 8.3%)	4 ( 8.3%)
Moderate (PSOM 1.5-2.0)	1 ( 4.2%)	1 ( 4.2%)	2 ( 4.2%)
Severe (PSOM $\geq 2.5$ )	2 ( 8.3%)	2 ( 8.3%)	4 ( 8.3%)
Support withdrawn	1 ( 4.2%)	1 ( 4.2%)	2 ( 4.2%)
<b>TOTAL</b>	<b>7 (29.2%)</b>	<b>7 (29.2%)</b>	<b>14 (29.2%)</b>

Tab. 3-11 Summary of neurological event status

#### Pump Replacement Due to Thrombus

During the course of the support, a clinician may have identified that a pump required replacement due to visualized thrombus within the blood pump. These replacements were not considered adverse events. However, these were nonetheless regarded as sentinel events due to their frequency and association with thromboemboli.

In the primary cohorts, 24 (50%) of the subjects had at least one pump replacement due to suspected thrombus (11 Cohort 1, 13 Cohort 2). The number of pump replacements ranged from 0 to 4 per subject. The average number of replacements per subject was  $0.9 \pm 1.2$ . However, subjects were supported on the device for varying lengths of time therefore it may be more informative to consider the replacements per length of time on device. The average replacements-per-day on device was  $0.02 \pm 0.03$  per day.

At the IDE sites, 57 (52.3%) of the 109 subjects had at least one pump replacement due to thrombus (11 Cohort 1, 14 Cohort 1 CAP, 13 Cohort 2, and 19 Cohort 3). The number of pump replacements ranged from 0 to 6 per subject. The average number of replacements per subject was  $1.1 \pm 1.4$  and the average replacements-per-day on device was  $0.02 \pm 0.03$  per day.

Additionally, 95 subjects were enrolled at non-IDE sites. Of the 204 subjects, 93 (45.6%) subjects had at least one pump replacement due to thrombus (11 Cohort 1, 14 Cohort 1 CAP, 13 Cohort 2, and 19 Cohort 3, 36 Cohort 3 Non-IDE). The number of pump replacements ranged from 0 to 6 per subject. The average number of replacements per subject was  $1.1 \pm 1.4$  and the average replacements-per-day on device was  $0.02 \pm 0.03$  per day.

Cohort	N	# Subjects with at least 1 replacement	Total number of replacement	Replacements per Subject	Total Days on Device	Replacements per Days on Support	Time to first replacement (days)
primary Cohorts*	48	25 (50.0%)	43	$0.9 \pm 1.2$ 0 - 4	2787	$0.02 \pm 0.03$ 0.00 - 0.13	$24.1 \pm 19.7$ 4 - 105
IDE Cohorts	109	57 (52.3%)	114	$1.1 \pm 1.4$ 0 - 6	6350	$0.02 \pm 0.03$ 0.00 - 0.18	$19.1 \pm 16.9$ 2 - 105
Non-IDE Cohorts	95	36 (37.9%)	58	$0.6 \pm 1.0$ 0 - 4	7240	$0.01 \pm 0.03$ 0.00 - 0.27	$41.9 \pm 44.6$ 2 - 198
Total	204	93 (45.6%)	172	$0.8 \pm 1.2$ 0 - 6	13590	$0.02 \pm 0.03$ 0.00 - 0.27	$27.8 \pm 32.3$ 2 - 198

Tab. 3-12 Pump replacement

\* Note: the 48 subjects in the “Primary Cohorts” group are a subset of the “IDE Cohorts” group (n=109)

### 3.6.6.3 Death information

Two subjects in each of the primary cohorts died after support was withdrawn. The 4 subjects were supported a median time of 28.5 days ranging from 0 to 144 days (mean  $\pm$  std:  $50.3 \pm 64.4$  days). Of the 4 subjects who died, 75% (3/4) were supported with ECMO at the time of EXCOR implant.

The CEC reviewed all deaths at the IDE sites and assigned primary and secondary causes of death. These causes are summarized by subject in the following table.



Patient	Days on Device	Primary Cause	Secondary Cause(s)
<b>COHORT 1 (2 deaths/ 24 subjects)</b>			
#1	0	Pulmonary Respiratory Failure	Cardiovascular: Left A-V valve regurgitation
#2	38	CNS: Multiple ischemic strokes	None
<b>COHORT 2 (2 deaths/ 24 subjects)</b>			
#3	144	Other: Arterial CNS and non-CNS Thromboembolism	Infection
#4	19	CNS: Large ischemic strokes with hemorrhagic conversion	Other: Tonsillar herniation

Tab. 3-13 Primary and secondary cause of death

### 3.6.7 Conclusion

Despite the reported SAEs, 42 of the 48 subjects supported by the EXCOR were adequately supported to transplant and 1 subject was able to be weaned successfully from the device after 9 days of support yielding an 89.6% success rate (43/48). The device supported children safely to cardiac transplantation for a median transplant eligible time of 27.5 and 42.5 days for cohort 1 and 2 respectively. Only one subject was temporarily removed from transplant eligibility during their support and was eventually relisted and transplanted.

Data that strongly supports the consideration for probable benefit is summarized for both Cohort 1 and 2 subjects as shown in the following tables.

#### Probable Benefit

Cohort	N	Outcome				Success (Transplant or Weaned-Recovered)
		Transplant	Weaned-Recovered	Weaned-Failure	Died	
Cohort 1	24	21	0	1	2	21/24 (87.5%)
Cohort 2	24	21	1	0	2	22/24 (91.7%)
<b>Total</b>	<b>48</b>	<b>42</b>	<b>1</b>	<b>1</b>	<b>4</b>	<b>43/48 (89.6%)</b>

Tab. 3-14 Probable Benefit

**Post-Explant/Transplant Follow-up**

Cohort	N	Outcome	30 days post-explant		1 year post-explant	
		# Explanted	# (%) alive 30 days	Lost to Follow-up	# (%) alive 1 Year	Lost to Follow-up
Cohort 1	24	22	22/22 (100%)	n/a	17/22 (77%)	0
Cohort 2	24	22	21/22 (95%)	1*	16/17 (94%)**	1
<b>Total</b>	<b>48</b>	<b>44</b>	<b>43/44 (97.7%)</b>	<b>1</b>	<b>33/39 (85%)</b>	<b>1</b>

\* 1 subject was weaned and returned to home

\*\* 5 subjects have regular contact with the site for post transplant care but are not 1 year post-explant as of this report: 3 subjects are due in June (last report alive at 313, 257 and 250 days), 1 subject is due in July (last report alive at 170 days) – verbal report; denominator includes 1 LTF

**Tab. 3-15** Post-explant/transplant status follow up

Beyond the primary endpoint of survival to transplant, the majority of subjects remain alive at 1 year post-explant/transplant as noted in the previous table.

HDE regulations require the device under study to show **reasonable safety and probable benefit**. In the EXCOR<sup>®</sup> Pediatric IDE trial the device demonstrated probable benefit as a bridge to transplantation in patients who are transplant eligible with severe left ventricular or biventricular dysfunction. The majority of patients implanted with the EXCOR were transplant eligible during device support with adequate end organ function and decreasing need for hemodynamic support such as intubation, sedation or ECMO support. While the concomitant support decreased, the subjects were able to spend more time awake, eating and ambulating.

The benefits offered to subjects implanted with the EXCOR<sup>®</sup> Pediatric include additional time to await transplant and improved hemodynamics allowing removal of pre-implant hemodynamic support allowing for increase time awake, ambulating and eating contributing to post implant transplant eligible wait times. These far-reaching benefits outweigh the risks associated with the adverse events that occurred.

## 3.7 Post Approval Study Summary

### 3.7.1 Study Objective

The purpose of the Post Approval Study (PAS) of the EXCOR<sup>®</sup> Pediatric VAD was to evaluate whether safety and outcomes of the device use in the commercial setting were comparable to the safety and outcomes of the device use in the IDE study.

### 3.7.2 Study Design

The study was an “all-comers” prospective study maintained by Berlin Heart consisting of pediatric patients aged 0-21 years implanted according to the IFU with the EXCOR<sup>®</sup> Pediatric who were transplant eligible children in need of mechanical circulatory support and who consented to be enrolled into the study.

### 3.7.3 Study Population

The study included subjects who met the Inclusion and Exclusion Criteria included below and for whom the EXCOR<sup>®</sup> Pediatric was indicated and not contraindicated per the product labeling.

**Inclusion Criteria**

- Patient requires mechanical circulatory support and is eligible for cardiac transplantation
- Legal guardian and patient (if age appropriate) understands the nature of the implant procedure and are willing to comply with associated follow-up evaluations, and provide written informed consent and assent prior to the procedure

**Exclusion Criteria**

- Patient is currently enrolled in EXCOR® Pediatric pre market study
- Patient is currently participating in another investigational device or drug trial which would confound the results of the study

**3.7.4 Data source**

Berlin Heart sponsored web-based Registry.

**3.7.5 Key Study Endpoints****Primary Safety Objective / Endpoint**

The primary safety objective of the study was to demonstrate that the serious adverse event (SAE) rate in subjects implanted with the EXCOR® Pediatric in this study was not greater than the rate experienced in the IDE study.

The primary endpoint was the SAE rate which was calculated as the total number of SAEs divided by the sum of days all subjects were supported on the EXCOR® Pediatric device.

A clinical events committee (CEC) met regularly during the course of the study to adjudicate the protocol-specified SAEs: major bleeding, major infection and neurological dysfunction events, and device malfunctions. The CEC also reviewed and assigned cause of death to any subject who died as a result of withdrawal of device support.

**Primary Efficacy Objective / Endpoint**

The primary effectiveness objective for the study was to assess the outcome following implantation of the EXCOR® Pediatric for transplant eligible children in need of mechanical circulatory support. The endpoint was defined as transplant, recovery of left ventricular function or death.

**3.7.6 Total number of Enrolled Study Sites and Subjects, Follow-up Rate**

A total of 39 subjects were enrolled at 19 investigational sites. All subjects were followed for the duration of device support. Subjects explanted from the device will continue to be followed for 24 months post explant.

**3.7.7 Study visits and length of follow-up**

Clinical data recorded in hospital records was collected at the time of pre-implant, implant, planned follow-ups (3 weeks, 6 weeks, 3 months, 6 months and every 3 months thereafter while on device support and up to transplant/recovery). Following explant of the device, follow-up visits were scheduled at hospital discharge, 12 months post explant and 24 months post explant.

### 3.7.8 Results

#### 3.7.8.1 Primary Safety

The total time on device support for the study subjects was 4216 days. There were 102 SAEs reported for the 39 subjects yielding a rate of 0.024 events per patient-day (95% Poisson confidence interval: 0.020 – 0.029). The difference between the event rate in the PAS study and the IDE rate 0.071 was statistically significantly lower (p-value <0.0001).

The following table summarizes the reported SAEs with their adjudicated results.

Event Category	# event	# subjects with event n (% of 39)	Events / Subject # /39
<b>Adjudicated SAEs</b>			
Major Bleeding	23	16 (41.0%)	0.59
Major Infection:	20	15 (38.5%)	0.51
Localized non-device	3	3 ( 7.7%)	0.08
Percutaneous Site and/or Pocket Infection	8	6 (15.4%)	0.21
Internal Pump Component, Inflow or Outflow Tract Infection	2	2 ( 5.1%)	0.05
Sepsis	7	7 (17.9%)	0.18
Neurological dysfunction:	17	13 (33.3%)	0.44
TIA	0	0 ( 0.0%)	0.00
Ischemic CVA	8	6 (15.4%)	0.21
Hemorrhagic CVA	5	5 (12.8%)	0.13
Ischemic/Hemorrhagic CVA	4	3 ( 7.7%)	0.10
New abnormality of head ultrasound	0	0 ( 0.0%)	0.00
EEG positive for seizure activity with or without clinical seizure	0	0 ( 0.0%)	0.00
Other			
• Covert stroke	3	3 ( 7.7%)	0.08
• Seizure	2	2 ( 5.1%)	0.05
• Encephalopathy	1	1 ( 2.6%)	0.03

**Tab. 3-16** EXCOR® Pediatric Post Approval Study Serious Adverse Events

<b>Event Category</b>	<b># event</b>	<b># subjects with event n (% of 39)</b>	<b>Events / Subject # /39</b>
<b>Other SAEs</b>			
Hepatic Dysfunction	2	2 ( 5.1%)	0.05
Hypertension	4	4 (10.3%)	0.10
Pericardial effusion with tamponade	1	1 ( 2.6%)	0.03
Pericardial effusion without tamponade	3	3 ( 7.7%)	0.08
Psychiatric episode	1	1 ( 2.6%)	0.03
Renal Dysfunction-Chronic	1	1 ( 2.6%)	0.03
Respiratory failure	9	7 (17.9%)	0.23
Right heart failure	3	3 ( 7.7%)	0.08
Venous Thromboembolism	3	2 ( 5.1%)	0.08
Other	9	8 (20.5%)	0.23
<b>TOTAL</b>	<b>102</b>	<b>32 (82.0%)</b>	<b>2.36</b>

**Tab. 3-16** EXCOR® Pediatric Post Approval Study Serious Adverse Events

### 3.7.8.2 Primary Efficacy Endpoints

Twenty-seven (27) of the 39 (69.2%) subjects were successfully transplanted or weaned from the device. Total support time ranged from 0 to 457 days with an average time of 108.1 days (standard deviation=118.9) and median of 63 days (IQR=20, 160).

The following table details the outcomes for the study subjects.

<b>Outcome</b>	<b>n (% of 39)</b>
Transplant	25 (64.1%)
Weaned; alive > 30 days	2 ( 5.1%)
Escalated to ECMO <sup>1</sup>	2 ( 5.1%)
Death	10 (25.6%)

<sup>1</sup> subjects died after transition

**Tab. 3-17** EXCOR® Pediatric Post Approval Study Outcomes

### **3.7.8.3 Study Strength and Weaknesses**

#### **Strengths:**

The study was a prospective study with pre-defined hypotheses and statistically calculated sample size. A central committee adjudicated the major serious adverse events (major bleeding, major infection, neurological dysfunction) as well as device malfunctions and deaths. Follow-up rate was 100% as all subjects remained in the hospital while on device support and, therefore, all follow-up visits were conducted.

#### **Weaknesses:**

The enrolled subjects showed a higher risk profile when compared to the IDE cohort and were smaller, younger, spent longer time on support, and more patients presented with CHD, especially single ventricle physiology.

## 4 Description: blood pump, cannulae and accessories

EXCOR is an extracorporeal electro-pneumatically driven ventricular assist device. It can be used for either univentricular or biventricular support. EXCOR is comprised of the following permanently active components:

- extracorporeal blood pump(s)
- inflow and outflow cannula(e)
- 1 driving tube for each blood pump
- Ikus

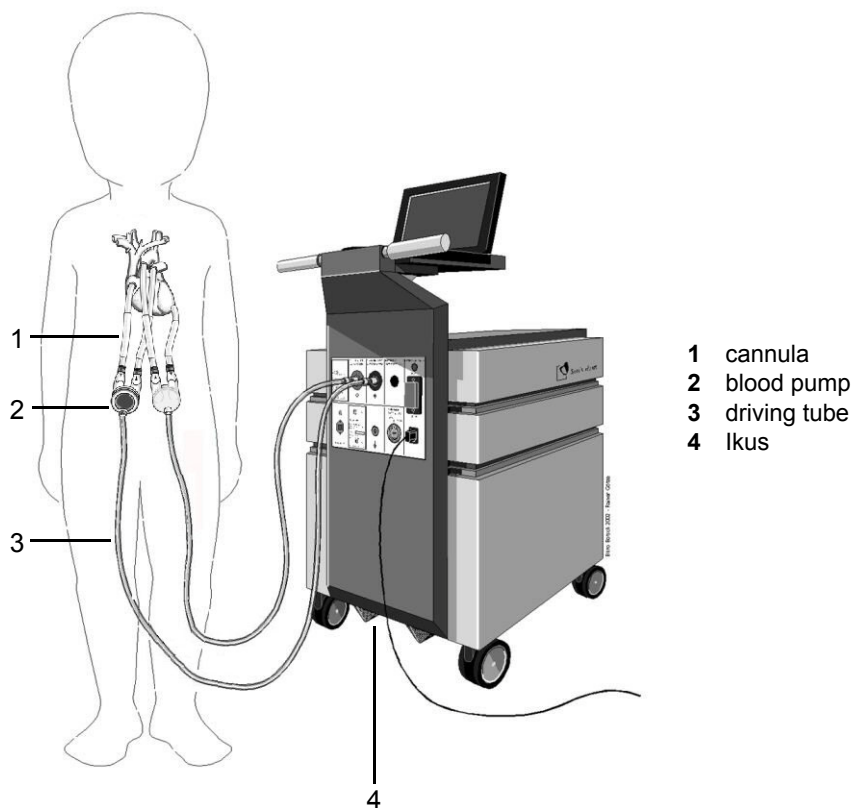

**Fig. 4-1** EXCOR shown in situ as a biventricular assist device in pediatric application

### Overview

The blood flows from the atrium or the ventricle through the inflow cannula into the blood chamber of the pump and then from this blood chamber through the outflow cannula into the aorta or into the pulmonary artery. A driving tube is used to connect the air chamber of the pump to the electro-pneumatic Stationary Driving Unit Ikus. Ikus generates the suction and driving pressures required to move the triple-layer membrane separating the blood chamber from the air chamber.

## 4.1 EXCOR blood pumps

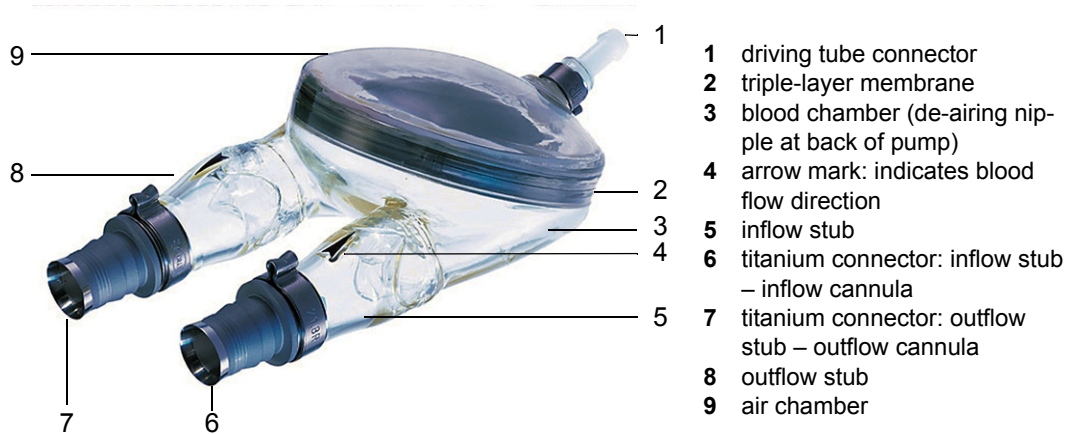

Fig. 4-2 60 ml blood pump

EXCOR blood pumps have a transparent polyurethane (PU) housing which is divided into an air chamber and a blood chamber by a triple-layer membrane.

The blood chamber has an inflow and an outflow stub to which the inflow and outflow cannula, respectively, are connected. The pump stubs themselves are made of polyurethane, the end of each stub is fitted with a titanium connector to which the cannula will be connected. The valves located in the pump stubs keep the blood flowing in one direction. EXCOR blood pumps are available with three-leaflet valves made of polyurethane (10 - 60 ml stroke volume).

All surfaces of the pump coming into contact with the blood are coated with a Carmeda® BioActive Surface (CBAS) coating. The transparent casing of the blood pump allows easy visual monitoring of the filling and emptying of the blood chamber.

The blood pump is equipped with a de-airing nipple which is used for de-airing the blood chamber when the pump is being commissioned.

The air chamber of the pump is equipped with a driving tube connector. This connector is used to connect the blood pump to the driving tube through which air is pumped from the Ikus. Ikus generates the suction and driving pressures required to move the blood pump's triple-layer membrane. A graphite powder layer is located between the membrane layers in order to minimize friction.

## 4.2 EXCOR cannulae

3 different types of cannulae are available for EXCOR in various sizes for each type:

- atrial cannulae (as inflow cannulae)
- LV apex cannulae (as inflow cannulae)
- arterial cannulae (as outflow cannulae)

The cannulae are made of tissue-friendly silicone. Polyester-velour suture rings enable convenient and safe anastomosis of the cannulae. The mid section of all cannulae is covered with polyester-velour in order to promote good ingrowth of the cannulae where they pass through the skin.

Some arterial cannulae have a shaping wire which allows the cannulae to be adapted to each individual patient's anatomic conditions.



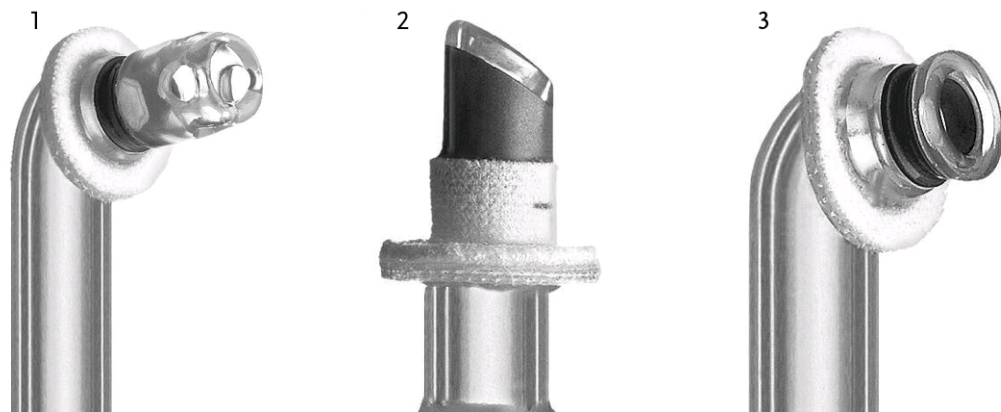

Fig. 4-3 Cannula heads: 1) atrial cannula, 2) LV apex cannula, 3) arterial cannula

### 4.3 EXCOR accessories

The following EXCOR accessories are required in order to commission and operate EXCOR:

- 1 driving tube (PVC) for each blood pump
- 2 tank units
- 1 accessory (T00L-002) set which includes:
  - membrane set
  - de-airing set (2 x trocar, 2 x de-airing tube)
  - de-airing hammer
  - tube connecting set (cable ties, cable-tie gun)

There is enough material in 1 accessory set (T00L-002) to commission 2 EXCOR blood pumps.

*This page was left blank intentionally*

## 5 Description: Ikus

### 5.1 Overview

The electro-pneumatic Ikus generates the suction and driving pressures required to drive the blood pump(s). The driving unit contains the pneumatic and electronic components as well as a laptop computer which serves as an interface to the operator.

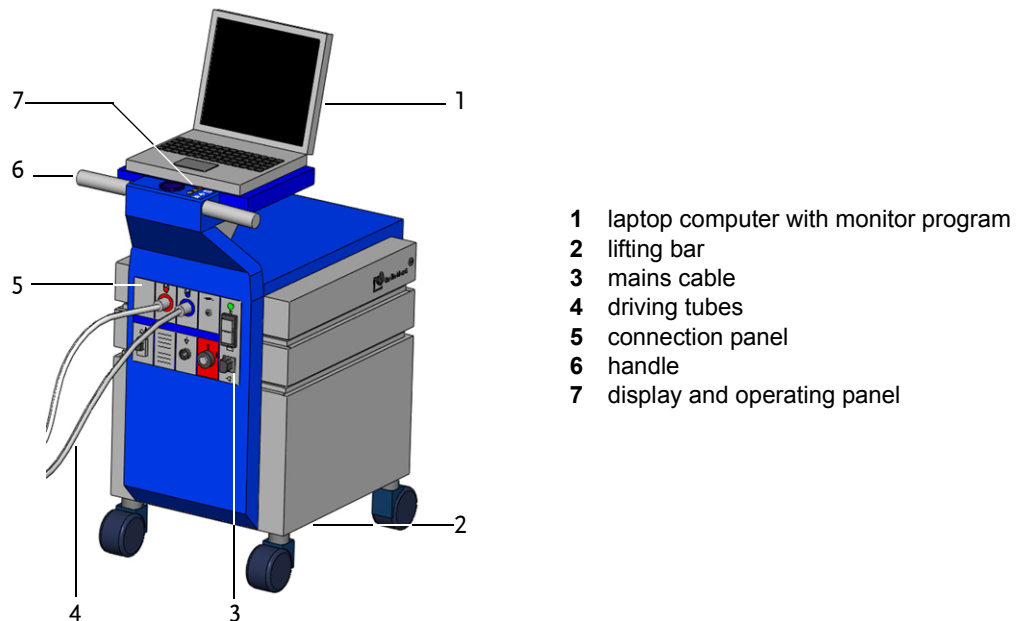

Fig. 5-1 Ikus

#### Pneumatic systems

The Ikus has 3 pneumatic systems operating independently of each other. One pneumatic system is required for each blood pump, while the 3<sup>rd</sup> serves as an emergency backup. Each pneumatic system includes:

- a compressor
- pressure and suction limiters
- pressure and vacuum cylinders
- control electronic
- control valves

The compressor, the pressure and the suction limiters deliver constant pressure conditions in the pressure and vacuum cylinders. The control valves at the outlet of each cylinder allow optimal adjustment of the positive and negative (suction) pressure values.

#### Control computer

The Ikus system has 2 control computers operating independently of each other: the active (main) control computer and the backup control computer.

#### Laptop with monitor program

Messages and pressure graphs in the monitor program inform the user of the current status and working condition of the system. In addition, the laptop computer is used

for commissioning the system and adjusting driving parameters. LOG files containing information on the system's operating status are recorded on the laptop's hard disk.

**Manual pump**

If there is no working Ikus available, the manual pump mounted on the Ikus can be used temporarily to drive the blood pump(s).

**USB stick to store LOG files**

A USB stick is provided to be used for reading out and storing LOG files.

Do not under any circumstances use any other USB stick on the *Ikus* laptop.

It is not permitted to use the USB stick for purposes other than reading out and storing the LOG files on the Ikus. Never connect other USB devices (e.g. wireless technology) to the USB port of the laptop than the delivered USB stick.

If the USB stick is no longer available, contact Berlin Heart, Inc. immediately and request a replacement stick.

## 5.2 Displays and operating elements

### 5.2.1 Connection panel

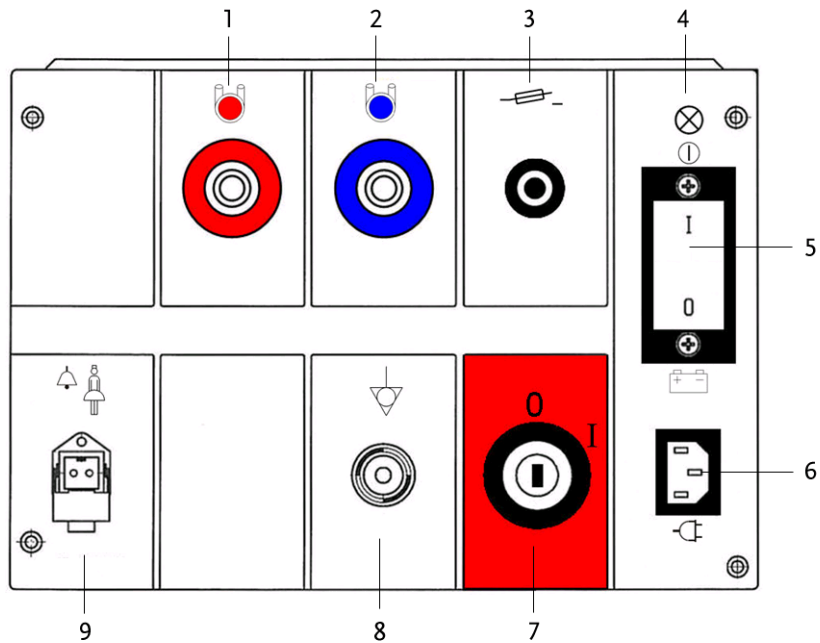
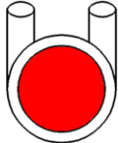
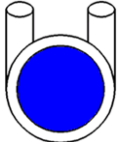





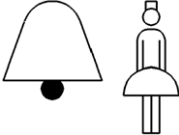

Fig. 5-2 Connection panel

	<p><b>1 Driving tube connectors, left blood pump, red</b></p> <p>The plug for the driving tube with the red marking is to be plugged to this connector.</p>
	<p><b>2 Driving tube connectors, right blood pump, blue</b></p> <p>The plug for the driving tube with the blue marking is to be plugged to this connector.</p>
	<p><b>3 Button <i>Circuit breaker</i></b></p> <p>The Ikus is protected against overcurrent. The circuit breaker is resettable (see section 15.8: Circuit breaker and battery fuse, page 208).</p>
	<p><b>4 Mains operation indicator</b></p> <p>Illuminated when using power supply (default situation).</p>
	<p><b>5 Power switch (toggle switch)</b></p>
	<p>In this switch position ([I] position), the drive is operated through the mains. The batteries are charged at the same time.</p>
	<p>In this switch position ([0] position), the mains power supply is interrupted. Ikus works in battery operation.</p>
	<p><b>6 Mains power connector (with plug clip)</b></p> <p>The Ikus is connected to the mains with the aid of the mains cable. The plug clip prevents an accidental loosening of the connection.</p>
	<p><b>7 Main switch (key switch; 0/ I)</b></p>
<p>I</p>	<p>Drive switched on</p>
<p>O</p>	<p>Drive switched off</p>

**Tab. 5-1** User controls and according symbols on the connection panel

	<p><b>8 Connector <i>Potential equalization</i></b></p> <p>Should several electric devices be positioned in the vicinity of the patient, they are to be connected to a central grounding point. To this end, the connector <i>Potential equalization</i> is to be used on the Ikus.</p>
	<p><b>9 Connector <i>External alarm (Nurse call)</i></b></p> <p>This connector serves as the link to the clinic's internal alarm system. A relay connects the internal alarm circuit with the connector <i>External alarm</i>. In the default configuration, the relay opens a pair of contacts whenever an alarm occurs, to set off an external alarm (via a 2-pin plug with a protective ground). Depending on the specifications of a specific hospital, the configuration of the connector <i>External alarm</i> can be modified so that the contact closes in case of an alarm. This setting modification is to be made by the Berlin Heart, Inc. service department.</p> <p>Technical specifications: see section 16.2: Technical specifications, page 217.</p>

Tab. 5-1 User controls and according symbols on the connection panel

**Main switch (key switch 0/ I) and power switch (toggle switch)**



To prevent the batteries from being discharged by mistake, ensure that the power switch (toggle switch) is set to [I] position even if the Ikus is set to [0] position at the main switch (key switch).

While the Ikus is being operated, keep it connected to the stationary protective ground via the connector *Potential equalization*.

The main switch (key switch) is used to turn the driving unit on and off. The main switch (key switch) can only be operated with the key.

However, a connection to the mains is not established until the power switch (toggle switch) is set to [I] position as well. The power switch (toggle switch) is only meant to serve as an emergency measure to protect the driving unit in case of mains power disturbance. If the power switch (toggle switch) is set to [0] position, the Ikus is disconnected from the mains power supply and will continue to run automatically in battery operation. During this process, the batteries are discharged. When they are depleted, the Ikus will stop. For this reason, the power switch (toggle switch) must always be set to [I] position even if the *Ikus* is set to [0] position at the main switch (key switch).

## 5.2.2 Display and operating panel

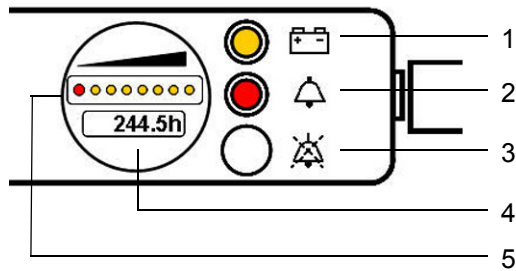

**Fig. 5-3** Display and operating panel

- 1 **Battery operation** The yellow LED lights up when the *Ikus* is running in battery operation
- 2 **Alarm** The red LED lights up or flashes (design dependent) whenever there is an alarm message which has not been acknowledged by the monitor program
- 3 **Mute alarm (Audio paused)** Button to temporarily mute an alarm message. The message remains displayed on the laptop.
- 4 **Operating hour counter** The number of all operating hours is displayed. When the *Ikus* was in operation for 2000 operating hours (maintenance interval) after the 1<sup>st</sup> commissioning respectively after the last maintenance the display starts blinking and shows **S -0.0h**. The number of hours (i.e. **S -10.0h**) are displayed exceeding the maintenance interval. A maintenance sticker (on the right side under the laptop holder) contains the information when maintenance is due.
- 5 **Battery charge indicator** 7 yellow LEDs indicate the battery charge state (see Fig. 5-3, page 61). The red LED lights up when the batteries are completely discharged!



**Fig. 5-4** Battery charge indicator and operating hour counter

The LEDs of the running time display correspond to the maximum technically possible battery running time. However, the maximum permitted off-mains (battery) operating time is 30 minutes. After 30 minutes of battery operation, a warning message **Batteries discharged - use power supply!** is displayed. Immediately switch the *Ikus* over to mains operation. Failure to do so may result in failure of the device and damage to the battery system.

## 5.2.3 Power supply



The *Ikus* is designed for stationary operation and to be run on mains. Do not run it on battery operation unless this is absolutely necessary (e.g. when moving the patient within the clinic or during a mains failure).

To prevent the batteries from aging quickly, every period of battery operation should be followed by at least 6 h of mains operation.

---

Failure to do like mentioned above will severely reduce the capacity of the batteries and will greatly shorten the maximum off-mains (battery) operating time! This particularly applies to situations where the Ikus is operated at temperatures exceeding 30 °C. Always monitor the charging level display (see Fig. 5-3, page 61)!

---

---

Whenever the Ikus is running in battery operation, the patient must always be accompanied by a person trained to use the manual pump. Thus the patient shall be guaranteed care in an emergency.

---

### **Mains operation with integral battery charging function (mains operation)**

Normally, the Ikus is powered by the mains. When the Ikus is in mains operation, the batteries which are completely or partially discharged are automatically recharged.

While the batteries are being charged, the battery charge indicator does not show the current charge correctly. The correct charge state is not indicated until the batteries have been fully charged. In this case, all yellow LEDs light up.

### **Battery operation**

The Ikus has a rechargeable battery module (with 2 rechargeable batteries of 12V each) which can supply the system with power independently of the mains for a maximum of 30 minutes. Whenever the Ikus is being run in battery operation, an acoustic signal sounds at 10-minute intervals. When the battery charge is low, the acoustic signal sounds 2 times per minute..

## **5.3 Operating modes**

### **5.3.1 Univentricular operation**

In univentricular operation, the driving tube of the blood pump is always connected to the red marked connector.

### **5.3.2 Biventricular operation**

#### **Synchronous pulsing left/right**

The systole cycles of the left and right blood pumps start simultaneously. Both pumps run at the same rate, the rate can only be adjusted via the left pump. The systolic pressure, diastolic pressure and the relative systolic duration can be set individually for each blood pump.

#### **Asynchronous pulsing left/right**

The systole cycle of the right blood pump is started when the left pump switches to the diastole cycle. Both pumps run at the same rate, the rate can only be adjusted via the left pump. The systolic pressure, diastolic pressure and the relative systolic duration can be set individually for each blood pump.

#### **Separate mode left/right**

Both blood pumps are operated completely independently of one another. All parameters can be adjusted as desired. **IMPORTANT:** The rate of the right pump may not exceed that of the left pump.



## 5.4 Laptop computer with monitor program

### NOTICE

If the laptop is switched off while the Ikus is in operation, the driving unit will continue to operate using the current parameter settings.

The laptop computer is integrated into the Ikus casing. The laptop, with its permanently installed monitor program, is used to start, set up and monitor the system.

The monitor program, when running, provides the user with a continuous stream of data on the system's condition, as well as information on events and function faults. At the same time, relevant data is stored on the hard disk for subsequent evaluation. A detailed description of the monitor program is given in chapter 6: Instructions for use: Ikus, page 67.



Fig. 5-5 Laptop

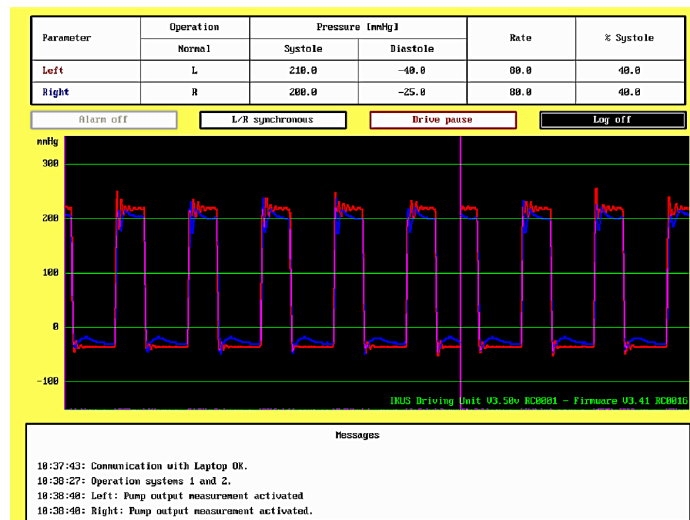

Fig. 5-6 Monitoring program

## 5.5 Safety

### 5.5.1 Redundant design of pneumatic systems in univentricular operation

The blood pump is powered by 1 pneumatic system. The other 2 systems are redundant and serve as backups. If the active system fails, one backup system drives the pump. There is still an additional, redundant system available.

### 5.5.2 Redundant design of pneumatic systems in biventricular operation

Each blood pump is powered by 1 pneumatic systems. The 3<sup>rd</sup> system is redundant and serves as a backup. If one of the active systems fails, the 3<sup>rd</sup> (backup) system drives the corresponding pump. The performance of the Ikus remains the same. If 2 systems should fail, the remaining pneumatic system will drive both pumps. In this case, the Ikus is running in emergency operating mode.



#### Normal operation

System 1 left pump  
 System 2 right pump  
 System 3 backup

#### Failure of 1 system

System 1 failure  
 System 2 right pump  
 System 3 left pump  
 Message **Backup operation left. Contact customer service.** is displayed.

#### Failure of 2 systems

System 1 failure  
 System 2 failure  
 System 3 left and right pump  
 Message **Emergency operation System 3. Contact service now!** is displayed.

Fig. 5-7 Pneumatic system redundancy in biventricular operation

#### Emergency operating mode

If 2 pneumatic systems fail while in biventricular operation, the remaining system will drive both blood pumps. In this case, the *Ikus* will be operated in synchronous mode with a 250 mmHg systolic pressure, -100 mmHg diastolic pressure, 70 bpm and a relative systolic duration period of 40 %.

### 5.5.3 Control computer with redundancy design

The control computers are also designed to provide backup redundancy. The *Ikus* system has 2 independently operating control computers. The main computer controls the pneumatic systems and transmits important function-specific data to the laptop computer. The backup computer continuously compares its calculation results with those of the main computer. If it detects a difference, an error message is generated. For safety reasons, the control computers are located inside the *Ikus* casing and operate fully independently of the laptop.

#### Emergency pulsing

The final safety system of the drive’s electronic system is the emergency pulse circuit board. Should both control computers fail, this hardware takes over control of the system. In order to preclude all possible sources of faults, the emergency pulse circuit

board runs autonomously and can be influenced neither by the 2 control computers nor by the laptop.

In emergency pulse mode, the system will operate with the following settings:

#### **Synchronous mode (biventricular)**

	<b>Systol. pressure [mmHg]</b>	<b>Diastol. pressure [mmHg]</b>	<b>Rate [bpm]</b>	<b>Relat. systole duration [%]</b>
left	210	-40	70	40
right	150	-40	70	40

**Tab. 5-2** Settings in emergency pulse mode

#### **5.5.4 Battery operation**

If the mains fails, the batteries will supply power to the system for at least 30 minutes. In this case, the battery operation indicator lights up. An acoustic alarm sounds at 10-minute intervals and a new message will be shown on the monitor program, showing the time the system has already been running in battery operation. The LEDs on the control panel of the handle show the charge state of the batteries.

#### **5.5.5 Manual pump**

If a working Ikus is no longer available, the blood pump(s) can also be temporarily operated (even in BVAD mode) by the manual pump supplied with the system (see section 15.5: Driving blood pump(s) with the manual pump, page 204).

#### **5.5.6 Password-protected user profiles (access passwords)**

Only a user who has logged into the monitor program with the correct password will be allowed to change settings within the monitor program. When the system is delivered, a single default user profile is configured; up to 9 additional user profiles can be added. All system setting changes are logged specifically for the user who is carrying them out.

*This page was left blank intentionally*

## 6 Instructions for use: Ikus



**WARNING**

Do not install any other software on this laptop.

Make sure that the **<NumLk>** and the **<Caps Lock>** key on the laptop is deactivated. The status LED on the laptop, identified by a lock symbol and/or a numeral (e. g. 1) should be off (see Fig. 6-1, page 67 to Fig. 6-3, page 68)

Only use the USB stick provided with the device for saving data. Never connect any other USB stick to the laptop!

The laptop must be switched off before the USB stick is inserted in or removed from the USB port.

Check all the information and messages in the message window of the monitor program at least every 4 hours. If there is a message that indicates action must be taken, take the appropriate action and, if necessary, contact the Berlin Heart, Inc. emergency hotline.

When switching on the Ikus, always switch the Ikus on first and then the laptop and not vice versa.

**NOTICE**

For details on commissioning the system see chapter 7: Commissioning the Ikus and setting parameters, page 93.

The Ikus is controlled and monitored using the monitor program, which is permanently installed on the laptop. Only users who are properly logged in can use the monitor program to change system settings.

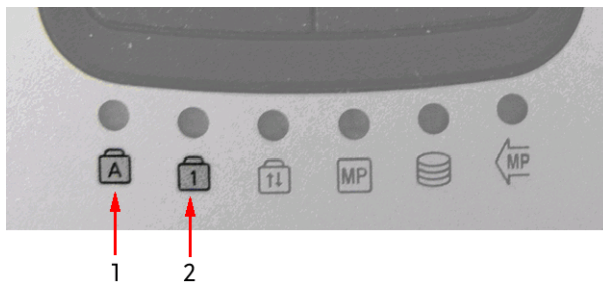

- 1 LED for **<Caps Lock>**
- 2 LED for **<NumLk>**

**Fig. 6-1** LEDs below the mouse pad

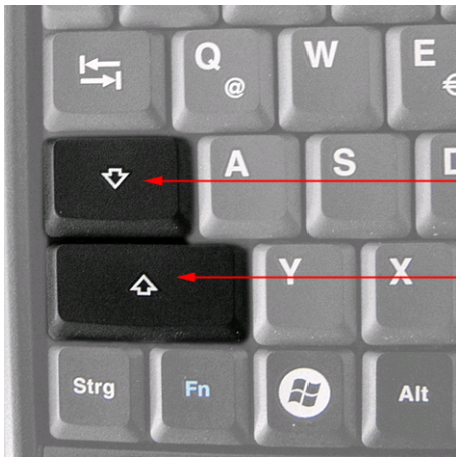

- 1 <Caps Lock>
- 2 Press <Shift>

Fig. 6-2 De-activate the Caps Lock



- 1 Press <NumLk>

Fig. 6-3 De-activate the Numeric Lock

### 6.1 Start menu

After the laptop is started, it will display the menu *Select language*.

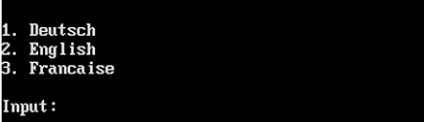

Fig. 6-4 Select language

Afterwards the start menu will open up and offer the following options:

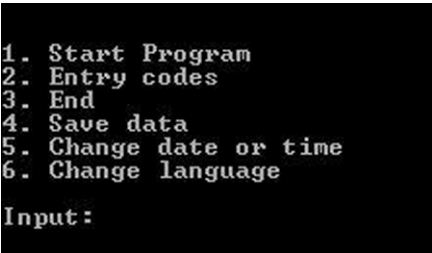

Fig. 6-5 Start menu

- 1. Start program                      Select this option to start the monitor program.

- |                               |  |
|-------------------------------|--|
| <b>2. Entry codes</b>         | With this option password-protected user profiles (user no.: 1 digit; password: combination of max. 32 digits) for the monitor program can be edited.    |
| <b>3. End</b>                 | This option will shut down the operating system before switching off the laptop. The Ikus will continue to operate using the current parameter settings. |
| <b>4. Save data</b>           | This option allows the LOG files to be saved on a USB stick. This should only be done after having consulted the service department.                     |
| <b>5. Change date or time</b> | This option enables the change of the system date and time on the laptop.  |
| <b>6. Change language</b>     | Use this option to choose a different language for the monitor program user interface.   |

### 6.1.1 Selecting an option in the start menu

After starting the monitor program(<1>, **1. Start program** in the start menu) the user has to log in with the user ID and password.

IMPORTANT: Before user profiles (<2>, **2. Entry codes**) can be entered, the initial user must first log in with user ID and password of the default user profile.

IMPORTANT: The default user profile is enclosed in the password envelope. This envelope can be found in the accessory box delivered with the Ikus.



Fig. 6-6 User ID

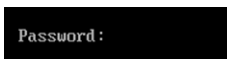

Fig. 6-7 Password

#### **➤ INSTRUCTION**

1. Type in the number of the menu item (e. g. <1> for **1. Start program**). The option is activated immediately

#### **🚫 ADVICE**

Keep the envelope containing the password in a safe place.

### 6.1.2 Configuring user passwords

A user profile (entry-code) is required to perform standard operating actions in the monitor program

IMPORTANT: The default user profile (user ID and password in password envelope) is required in order to be able to manage user profiles.

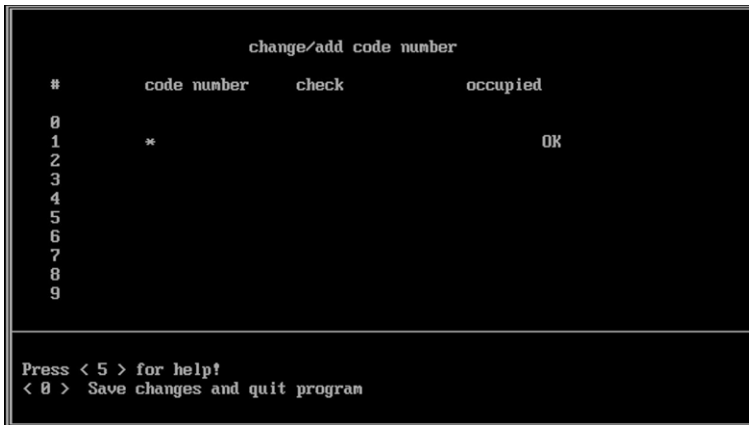

Fig. 6-8 Entry codes

**➤ INSTRUCTION**

1. If the monitor program is running: press **<F10>** to exit the monitor program. Confirm by pressing **<X>** or **<1>**.
2. From the start menu, select **2. Entry-codes (<2>)**.
3. Enter the default user profile code and confirm the input by pressing **<Enter>**. Now the password configuration program is started.
4. Use the arrow keys **<↓>/<↑>** to move the cursor to the desired user ID, then press **<Enter>** to confirm selection.
5. Enter the password (combination of max. 32 digits) and press **<Enter>** to confirm.
6. Repeat the entry and confirm with **<Enter>**.
7. If it is necessary, repeat steps 3 to 5 in order to configure additional user profiles.
8. To conclude and confirm all entries, press the **<0>** key. The passwords have now been assigned to the respective user IDs. The start menu is shown again.
9. In the start menu, select option **1. Start program (<1>)** to return to the monitor program.
10. Enter user ID and password, confirm by pressing **<Enter>**.

**Other password configuration options**

Key	Function
<b>&lt;ESC&gt;</b>	Discard all entries not yet confirmed with <b>&lt;0&gt;</b> and exit <b>2. Entry codes</b> .
<b>&lt;DEL&gt;</b>	Delete the selected user (press <b>&lt;Enter&gt;</b> to confirm)
<b>&lt;5&gt;</b>	Call up help text

Tab. 6-1 Other password configuration options



### 6.1.3 Saving data on USB stick

**NOTICE**

Consult the service department before proceeding with this option (refer to section 15.7: Reading out the LOG files, page 207).

### 6.1.4 Changing date or time



Fig. 6-9 Change date or time

**INSTRUCTION**

1. If the monitor program is running: press **<F10>** to exit the monitor program and confirm by pressing **<X>** or **<1>**.
2. From the start menu, select **5. Change date or time (<5>)**.
3. Move the cursor to the desired values using the **<←>** / **<→>** keys. Adjust the value with **<↓>/<↑>** (+/-1) and confirm with **<Enter>**.

**Additional options changing date or time**

Key	Function
<b>&lt;F6&gt;</b>	Switch between input field date and time fields
<b>&lt;F10&gt;</b>	Save settings and exit
<b>&lt;ESC&gt;</b>	Cancel and return to start menu

Tab. 6-2 Options changing date or time

## 6.2 Basic instructions for monitor program

### 6.2.1 Starting the monitor program

**INSTRUCTION**

1. The start menu is displayed on the screen. Select **1. Start program (<1>)**.
2. Enter the user ID, then the password. Confirm the password with **<Enter>**.

### 6.2.2 Shutting down the monitor program



Do not shut down the monitor program unless this is absolutely necessary (e. g. if new user profiles have to be set up). Restart the monitor program as soon as possible.

#### INSTRUCTION

1. Press **<F10>** and confirm by pressing **<X>** or **<1>**. The start menu is displayed on the laptop. The monitor program has now been shut down.

#### When the monitor program has been shut down:

- the system continues running with the currently set parameters
- no data on current events are recorded, the LOG files will be incomplete
- an acoustic signal and the indicator light on the handle control panel will alert the user of new messages. However there is no way to display the message that has been detected while the monitor program is shut down.

### 6.2.3 Logging in and out of the monitor program

IMPORTANT: This automatic forced logout does not occur after the first login during the very first commissioning of the Ikus.

IMPORTANT: The Ikus performs a self-test of the alarm circuit for each login procedure. If the self-test is completed successfully, the message **Acoustic alarm: OK** appears a few seconds later. IMPORTANT: The self-test does not occur if, at the time of login, an alarm is pending that was muted with the button *Mute alarm* (see section 5.2.2: Display and operating panel, page 61).

IMPORTANT: If a problem arises during the self-test of the alarm circuit, the acoustic signal continues for test purposes and cannot be muted during this phase. Acknowledgment is only possible when a message appears (**Alarm circuit test failed - buzzer remains off!** or **Acoustic alarm is not properly recognized**).

To select options in the monitor program, to change parameters or scroll through the message window a user has to be logged into the monitor program. If no entries are made for several minutes, the monitor program will log the user out automatically. The Ikus continues to operate using the current parameter settings. The standard view is displayed.

### 6.2.4 Logging in

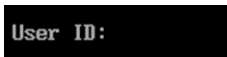

Fig. 6-10 User ID

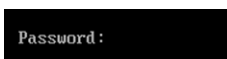

Fig. 6-11 Password

### ➤ INSTRUCTION

1. The monitor program is running. It now displays the field **User ID**. Enter user ID. The monitor program now displays the field **Password**.
2. Enter the password and confirm the password with **<Enter>**. The monitor program will now display the field **Log off**. The user now is logged into the monitor program.  
The alarm circuit test follows.

### Logging out

### ➤ INSTRUCTION

1. Select the menu item **Log off**, then press **<Enter>** to confirm. The monitor program now displays the field **User ID**. The user now is logged out of the monitor program. No further entries are possible until next login.

### Cautionary measure

To ensure patient's safety, the user always has to log out of the monitor program before leaving the vicinity of the system.

## 6.2.5 Standard view – monitor program



### WARNING

The displayed pressure graphs refer to the pneumatic pressures generated internally by the system and are given in millimeters of mercury [mmHg]. They do not display the patient's blood pressure and cannot replace diagnostic measures by the medical personnel.

**IMPORTANT:** The monitor program also has 2 other views, which, however, are only displayed when the *Ikus* is being started or can be called up by the command **Drive pause**.

- view *Select operating mode*, see Fig. 7-3, page 97
- view *Pump size and single-step mode*, see Fig. 7-7, page 100

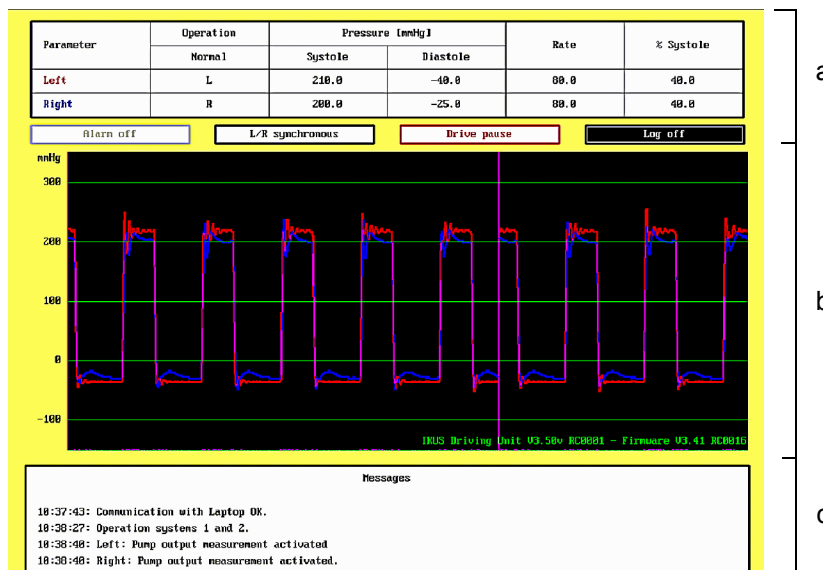

Fig. 6-12 Standard view of monitor program during start-test

- A Parameter table      currently set parameters are displayed and can be changed here
- B Pressure graphs      graphical display of the current pressure values in the respective pneumatic systems
- C Message window      information on the system status (e. g. **test operation**) and messages (error messages and messages confirming error correction; see chapter 14: Error Messages and corrective measures, page 171).

**IMPORTANT:** If the operator leaves the monitoring program or there is a failure of the monitoring program when there is an active alarm, the messages that had been displayed at that time will not be displayed again when the program is restarted. The messages can be recalled by Berlin Heart's service department.

**Monitor program functions**

Monitor and control system:

- If required: parameter adjustment
  - systolic pressure
  - diastolic pressure
  - rate
  - biventricular: operating mode (synchronous mode; asynchronous mode; separate mode left/right)
- View messages
- Acknowledge messages
- Pause drive
- Switch drive off

**6.2.6 Selecting monitor program options**

**➤ INSTRUCTION**

1. Use the <<->/<-> keys to move the cursor to the desired field. A pop-up menu will be displayed. To move to the next line up or down, the <<-> /<-> keys have to be pressed repeatedly.

Parameter	Operation	Pressure [mmHg]		Rate	% Systole
	Normal	Systole	Diastole		
Left	L	200.0		0.0	40.0
Right	R	170.0		0.0	40.0

Alarm off	L/R separate	OFF	Log off
-----------	--------------	-----	---------

**Fig. 6-13** Selecting monitor program options

- with grey frame                      field is not activated
- black/ red frame                    field is activated
- colored background                field is selected

## Selecting pump size(s) and cannula sizes

- INSTRUCTION**
1. Use the <↓>/<↑> keys to move the cursor to the desired field. All options that can be selected for this field are displayed.
  2. Pop-up menus in the parameter table: press <Enter> to confirm the selection.
  3. Pop-up menus *Pump size* and *Cannula size*: after selecting the size, exit the field with <←>/<→>. The pop-up menu is closed and the selected option is displayed.

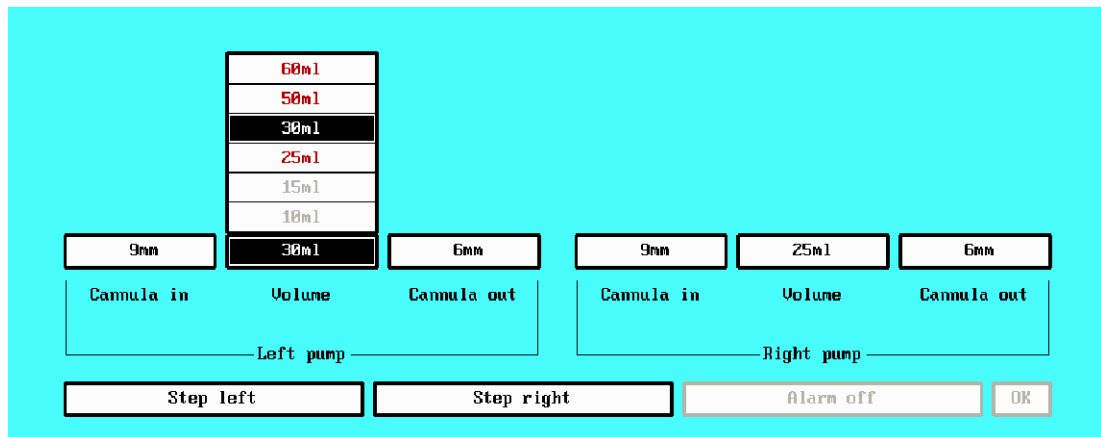

Fig. 6-14 Select pump size

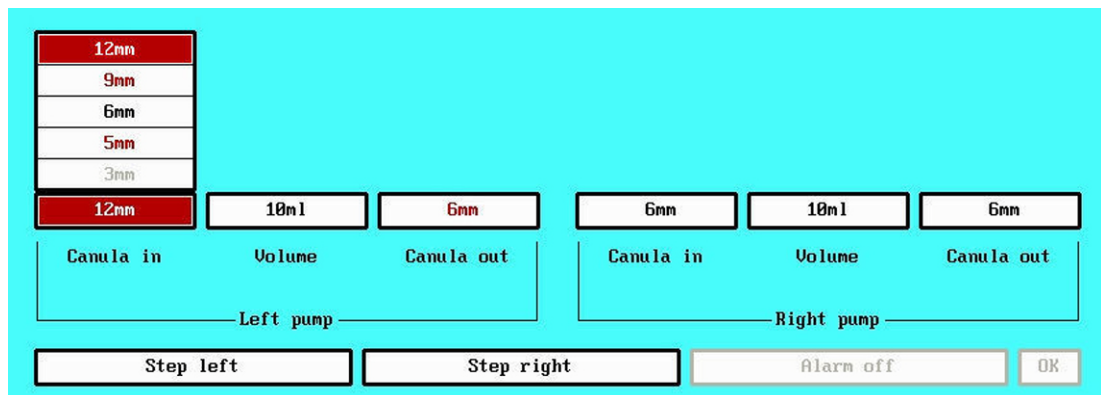

Fig. 6-15 Select cannulae size

The fields highlighted in red in the pop-up menus *Select pump size* and *Select cannulae size* can be chosen. However, they are not the recommended option for each individual case (see section 16.1.10: Maximum rates for the pump-cannula combinations, page 216 and section 16.1.11: Blood pump combinations in biventricular mode, page 217).

In individual cases, consideration is to be given as to whether a combination that is not recommended is to be selected.

The final decision on the combination of blood pumps and cannulae is to be reached by the implanting surgeon, in consultation with Berlin Heart, Inc., Clinical Affairs.

### 6.2.7 Adjusting the parameter values

**NOTICE** If the adjusted parameter was not confirmed with **<Enter>**, the parameter table will display the changed parameter until the automatic log off, but the Ikus will continue operating with the former value.

The changed parameter display can be Ed with **<Esc>**. The original value appears again in the parameter table.

To confirm the change, press **<Enter>**; the new value is displayed in the parameter table.

**INSTRUCTION**

1. Use the **<<->/<->** keys to move the cursor to the desired field in the parameter table. The selected field is given a colored background.
2. Use the **<↓>,<↑>/ <Bild-↓>,<Bild-↑>** keys to adjust the value, then press **<Enter>** to confirm. The system will now operate using the new value.
3. Visually check that the blood pump(s) is (are) filling and ejecting completely over a period of several pump cycles!

Parameter	Operation	Pressure [mmHg]		Rate	% Systole
	Normal	Systole	Diastole		
Left	L	200.0	-30.0	100.0	40.0
Right	R	170.0	-30.0	100.0	40.0

Fig. 6-16 Parameter table

Parameter	Range possible	<↓>/<↑> changes value by	<Bild-↓>/<Bild-↑> changes value by
Systolic pressure [mmHg]	60 to 350	2.5	25
Diastolic pressure [mmHg]	0 to -100	2.5	25
Rate [bpm]	30 to 150	1	10
Relative systolic duration [%]	20 to 70	1	10

Tab. 6-3 Parameter adjustment

## 6.2.8 Browsing in the message window

### ► INSTRUCTION

1. Press the <7> key to move the cursor in the message window.
2. Scroll through the messages: either 1 message at a time with <↓>/ <↑>; or 4 messages at a time with <Bild-↓>/ <Bild-↑>.
3. Exit the message window by pressing either <Esc> or <Enter>. The field **Log off** is automatically activated and appears with a black background.

## 6.3 Stopping the blood pump(s) and switching off the Ikus

Parameter	Operation	Pressure [mmHg]		Rate	% Systole
	Normal	Systole	Diastrole		
Left	L	200.0		0.0	40.0
Right	R	170.0		0.0	40.0

Alarm off	L/R separate	<ul style="list-style-type: none"> <li>Drive pause</li> <li>Pause left</li> <li>Pause right</li> <li>Drive OFF</li> <li>OFF</li> </ul>	Log off
-----------	--------------	--	---------

Fig. 6-17 Drive pause (with stop options)

The pop-up menu *Drive pause* offers the following options:

- **Drive pause**
- **Pause left**
- **Pause right** (only in biventricular operation)
- **Drive OFF**

### 6.3.1 Drive pause: stopping the Ikus temporarily

**IMPORTANT:** When restarting the system from a separate mode there can be an unintentional switch to the synchronous mode, although **L/R separate** continues to be displayed. The pressure graphs, however, distinctly indicate the synchronous mode.

### ► INSTRUCTION

1. Select **Drive pause**, then press <Enter> to confirm. Respond to the prompt in the dialog window by pressing the <X> key or the <1> key. The Ikus will stop. The view *Select operating mode* is displayed.

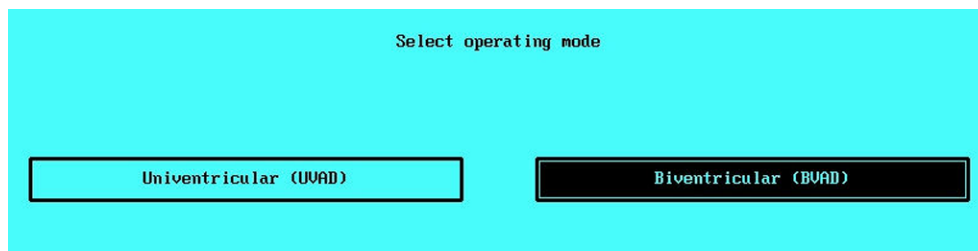

Fig. 6-18 Select operating mode

2. Select **Univentricular (UVAD)** or **Biventricular (BVAD)**, then confirm the selected operating mode with <Enter>. In biventricular mode the view *Pump size and single-step mode* appears. In univentricular mode, the seal test is performed first and then the view *Pump size and single-step mode* appears.

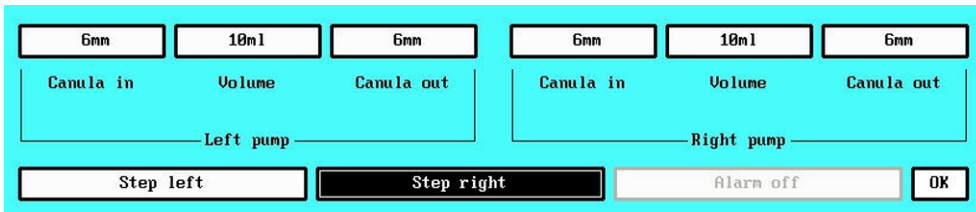

Fig. 6-19 Pump size and single-step mode

3. The cursor is located on the **OK** field. In order to restart the driving unit with the current settings, press the **<Enter>** key. **IMPORTANT:** If the user leaves the **OK** field before pressing **<Enter>**, at least once **Step left** or **Step right**, respectively has to be performed again. Only now the **OK** field is highlighted again and it is possible to confirm **OK** by pressing **<Enter>** (see section 7.2.3: Select the pump size, page 98).

### 6.3.2 Pause left/ Pause right: stopping an individual blood pump

**IMPORTANT:** The option **Pause right** is only available in biventricular mode. The option is displayed in univentricular mode, but it is not activated. It is only possible to select **Pause left**.

**➤ INSTRUCTION**

1. Select **Pause left** or **Pause right**, as required, then press **<Enter>** to confirm. Respond to the prompt in the dialog window by pressing the **<X>** key or the **<1>** key. The selected pump will stop. The view *Pump size and single-step mode* is displayed.
2. To restart the pump, at least once **Step left** or **Step right**, respectively has to be performed (see section 7.2.3: Select the pump size, page 98).

### 6.3.3 Drive OFF: switching the Ikus off



The Ikus power switch (toggle switch) must always be in the **[I]** position even if the Ikus is set to **[O]** position at the main switch (key switch)!



The sequence of operations below must always be followed.

Do not switch the Ikus off unless the batteries are fully charged (i.e. all yellow charge indicator LEDs are on).

Keep all driving tube connectors covered at all times when not in use.



**INSTRUCTION**

1. Check the following: Are the batteries fully charged? (all yellow charge indicator LEDs should be lit). If not: Continue as instructed here up to and including step 4. Then switch off the laptop and leave the Ikus switched on until all yellow LEDs light up. Then switch the Ikus off using the main switch (key switch).
2. In the monitor program, select the **Drive OFF** option and press **<Enter>** to confirm.
3. Respond to the prompt in the dialog window by pressing the **<X>** key or the **<1>** key. The driving unit stops operation immediately and writes an operating LOG file.
4. Wait until the LOG file has been completed. When the message **Switch drive off with main switch!** appears, press **<F10>** to shut down the monitor program. Confirm by pressing **<X>** or **<1>**.
5. Select option **3. End (<3>)** in the start menu and switch off the laptop.
6. Switch the Ikus off, when the batteries are fully charged. To do so, turn the main switch (key switch) to **[0]** position.

**IMPORTANT:** Always use the main switch (key switch) to switch off the Ikus.

**IMPORTANT:** If the Ikus is not in use, run it once a month for 24 hours in order to ensure that all batteries are adequately charged. Refer to section 6.5.1: Routine start-test when not in operation, page 83. Otherwise there is a risk that the Ikus no longer functions correctly.

## 6.4 Switching between mains and battery operation

**WARNING**

The Ikus is designed for stationary operation and to be run on mains. Do not run it on battery operation unless this is absolutely necessary (e.g. when moving the patient within the clinic or during a mains failure).

Whenever the Ikus is running in battery operation, the patient must always be accompanied by a person trained to use the manual pump.

Do not disconnect the Ikus from the mains unless the battery charge indicator shows that the batteries are full charged (all yellow LEDs light up). **IMPORTANT:** In order to prevent premature discharge and aging of the batteries, the Ikus should be run in mains operation for at least 6 hours after every period of battery operation.

If the LED of the charge indicator flash on and off or if the message **Batteries discharged - use power supply!** is shown, switch to mains operation immediately!

If the batteries are discharged completely (red LED of the charge indicator lights up), there is a danger of a total malfunction of the Ikus if battery operation is continued, and that the batteries will be damaged. If this happens, it can not be guaranteed that the Ikus will restart after connecting it to the mains.

---

When the battery charge is low, the acoustic signal sounds every minute. The Ikus must be connected to the mains operation immediately.

---

 **ADVICE**

Always take along the mains cable when operating the Ikus in battery operation. In this way the system can be connected briefly to the mains again if it becomes necessary.  
If the patient has to be transported within the clinic choose a route as close to the power sockets as possible. Thus at any time the Ikus can be connected to the mains.

---



**Fig. 6-20** Battery charge indicator with 7 yellow LEDs, red LED to the left of yellow LEDs

**IMPORTANT:** Whenever the Ikus is being run on battery power, an acoustic signal sounds at 10-minute intervals. These signals can be either acknowledged on the laptop or muted by pressing the button *Mute alarm* on the operating panel.

**IMPORTANT:** Battery charge indicator: 7 yellow LEDs indicate the battery charge state (see above). The red LED lights up when the batteries are completely discharged!

### Switching over to battery operation

 **INSTRUCTION**

1. Disconnect the Ikus from the mains. To do so, pull the plug from the socket. Never pull the cable from the driving unit.
2. Battery operation indicator lights up.
3. Observe all indicators and messages while the Ikus is running on battery power (see Tab. 6-4, page 81).

**Behavior of the Ikus with various battery charges**

<b>What?</b>	<b>When?</b>	<b>Meaning</b>
The charge indicator shows the battery charge status	always This does not apply while the batteries are being charged (all yellow LEDs light up only <b>after</b> the batteries have been completely recharged)	charge status
Battery charge indicator lights up	during battery operation	battery operation
Message: <b>Battery operation</b> , signal tone	every 10 minutes	<b>OK</b> ; can be either acknowledged on the laptop or muted by pressing the button <i>Mute alarm</i> on the operating panel
Message: <b>Batteries discharged - use power supply!</b>	after 30 minutes of operation, then at 10 minute intervals	The permissible runtime of 30 minutes on battery operation has been reached. Change to mains operation!
Message: <b>Batteries discharged - use power supply!</b>	Batteries have reached low charge state, 2-times per minute repeatedly	maximum possible runtime: only a few minutes. Switch to mains operation immediately!
yellow LED blinks (left)	Batteries are about to reach maximum possible runtime	Prewarning! Switch to mains operation immediately!
Message: <b>n - use power supply!</b> ...together with message (1-time): <b>Fault:</b> <b>0000 0011 1101 1000</b> <b>(fault in power supply)</b> red LED of the charge indicator also lights up	Batteries are now no longer charged. (Batteries are completely dead)  2-times per minute repeatedly	Batteries are completely dead! Residual runtime: 0 minutes! Immediately switch to mains operation! Danger of total malfunction of the Ikus!

**Tab. 6-4** Displays and messages during battery operation mode

What?	When?	Meaning
Pump stands still - no further pump function; acoustic alarm is still audible	Batteries are complete emptied or there is a serious fault in the batteries	Immediately connect the Ikus to the mains. Until that supply the patient with the manual pump.
Acoustic alarm is audible; the displays are off and it is not possible to perform any action on the laptop	Batteries are defective or mains failure	Immediately connect the Ikus to the mains. Until that supply the patient with the manual pump.

Tab. 6-4 Displays and messages during battery operation mode

### Switching over to mains operation

**➤ INSTRUCTION**

1. Connect the Ikus to the mains.
2. The indicator *Mains operation* lights up. The indicator *Battery operation* in the handle goes out. The battery is now being charged.

## 6.5 Changing over from univentricular to biventricular operation

**⚠ CAUTION**

After changing over to biventricular operation the device is operating in separate mode. All parameters are reset to the default parameters (see Tab. 15-3, page 203). The patient-customized parameters have to be adjusted again.

**➤ INSTRUCTION**

1. The pump which is to be connected must be already de-aired and connected to the cannulae.
2. In the monitor program, select the option **Drive pause** (see Fig. 6-17, page 77) and press **<Enter>** to confirm. Confirm the selection in the dialog window by pressing **<X>** or **<1>**. The active pump will stop. The view *Select operating mode* appears.
3. Open the driving tube connector identified by a blue marking.
4. When changing from univentricular support to BVAD: ensure the LVAD pump is attached to the red connector and RVAD pump is attached to the blue connector. To do so, take hold of the plug's release sleeve and pull the plug out of the socket.
5. Plug the driving tube of the de-aired new pump into the free driving tube connector. The sound of the plug snapping into place is clearly audible. Check that the plug is securely connected. To do so, grip the release sleeve above the grooved section and pull on it. Do not pull from the release sleeve, and never from the tube!
6. Select **Biventricular (BVAD)** and confirm with **<Enter>**. All following steps are the same as required for the start-up procedure. See chapter 7: Commissioning the Ikus and setting parameters, page 93.

### 6.5.1 Routine start-test when not in operation

**IMPORTANT:** If the Ikus is not in use, run it once a month for 24 hours in order to ensure that all batteries are adequately charged. Refer to section 6.5.1: Routine start-test when not in operation, page 83. Otherwise there is a risk that the Ikus no longer functions correctly.

#### ➤ INSTRUCTION

1. Procedure as described in section 7.1.1: Connecting the tank unit, page 94 and section 7.1.2: Switching on the Ikus, page 95.
2. Wait 24 hours.
3. Procedure as described in section 6.2.1: Starting the monitor program, page 71 and section 7.1.4: Setting the test parameters, page 95.
4. Observe and evaluate the curve representation.
5. Select the option **Drive OFF**, then confirm with **<Enter>**.
6. Confirm the selection in the dialog window by pressing **<X>** or **<1>**. The system immediately stops the operation and writes an operating LOG file.
7. Wait until the LOG file is complete (message: **Switch off drive with main key switch**).
8. End the monitor program and switch off the laptop.
9. All of the yellow battery LEDs are lighted: Switch off the Ikus. To do so, set the main switch (key switch) to **[0]** position.  
Not all yellow LEDs are lit up: Leave the Ikus on the power supply until all of the yellow LEDs light up. Then set the main switch (key switch) to **[0]** position.
10. Disconnect both tank units from the Ikus.
11. Seal the driving tube connection sockets with seal plugs.

#### If the system detects an error in the start-up test

#### ➤ INSTRUCTION

1. End the monitor program according to the instructions in the dialog.
2. Switch off the Ikus with the main switch (key switch).  
**IMPORTANT:** The power switch (toggle switch) remains on **[/]** position!
3. **IMPORTANT:** Wait 10 minutes.
4. Restart the start-up procedure (see above).

If the system again detects an error in the start-up test or not all of the battery LEDs are illuminated after 24 hours, notify Berlin Heart:



**HOTLINE**

**Notify Berlin Heart! 866.249.0128**

## 6.6 Moving the Ikus

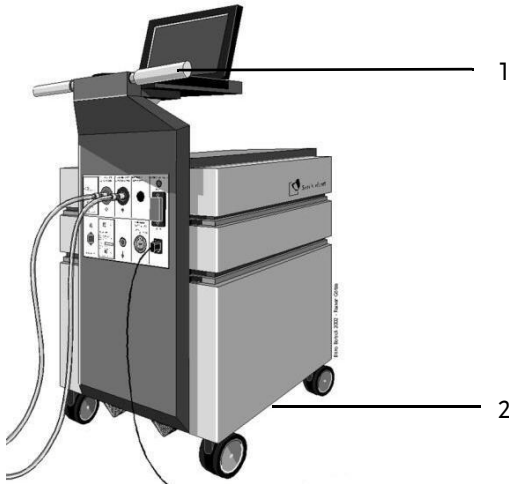

- 1 handle: push the Ikus
- 2 lifting bar: the Ikus can be lifted here

Fig. 6-21 Handle and lifting bar

### Transport within the clinic



**WARNING**

---

To move the Ikus unit: push only, using the handle provided for this purpose. Avoid any sudden jerky motion. When passing over smaller obstructions, exercise extreme caution, pulling the Ikus unit backwards (i.e. handle first) across the obstruction if necessary.

---

---

To lift the *Ikus*: use only the lifting bars at the lower edge at each side of the unit to hold and lift it. Never attempt to lift the *Ikus* by its handle. The *Ikus* must always be lifted by at least 2 people, preferably 4.

---

---

Rolling the *Ikus* over sloping surfaces: ensure that the person pushing it is strong enough to push the *Ikus* in a controlled manner. The slope of the surface may not be steeper than 10° (exception: packing/unpacking of the *Ikus* into/ from the transport crate). Otherwise there is a risk of injury to the transporting persons or of damaging the *Ikus*!

---

---

If it is necessary to transport the patient within the clinic ensure that he is accompanied by a person trained to use the manual pump.

---

## 6.7 Transportation and packaging



**CAUTION**

---

Keep all driving tube connectors covered at all times when not in use.

---

---

To lift the *Ikus*: only use the lifting bars situated at the lower edge on each side of the unit to hold and lift it. Never attempt to lift the *Ikus* by the handle.

---

---

To transport the *Ikus*, only the supplied original transport crate must be used.

---



---

Make sure that the *Ikus* is standing firmly and securely in the crate and that the crate is closed and sealed properly.

---



---

The crate must always be transported as marked. Do not tip the *Ikus* driving unit stored in the transport crate or turn it upside down.

---



---

Always observe a resting period of 6 hours after each transportation before switching on the *Ikus*!

---

**NOTICE**

---

During storage and transportation, the power switch (toggle switch) should be in [I] position.

---



---

To transport the *Ikus*, only use the original transport crate supplied.

---



---

Ensure that the *Ikus* is placed firmly and securely inside the transport crate.

---

**Ikus Accessories**

- 1 Instruction for use (supplied separately)
- 2 Tank units (supplied separately)
- 2 Keys
- 1 Power cable
- 1 Alarm connector
- 1 Envelope with password

Also see section 16.4: Sample copy: *Ikus Incoming Checklist*, page 221.

**6.7.1 Unloading the Ikus from the shipping crate****NOTICE**

---

Do not discard the shipping crate!

---

**➤ INSTRUCTION**

1. Follow inspection steps per *Ikus Incoming Checklist*.
2. Place the crate with its back against a wall and/ or lock the brakes to prevent the crate from moving during unloading.
3. Open the door latches. Flip open the secure latch and turn counter clockwise to disengage latch from front door.
4. Swing front door open to the left.
5. Unlatch the ramp safety retainer.
6. Open the ramp while holding the black securing plate behind the ramp.
7. Open the front securing plate (is connected to the crate with a rope) and place the plate to the right of the crate.

8. Remove the white accessory box.
9. Disengage the *Ikus* front wheel brake (pulling the lever upwards).
10. Stand on the ramp and carefully pull out the *Ikus* by the handle bar.

For assistance please:



**HOTLINE**

**Notify Berlin Heart! 866.249.0128**

### 6.7.2 Loading the *Ikus* into the shipping crate

During transport, the key remains in the main switch (key switch) in the [0] position.

Dimensions of the *Ikus* (W x H x D): 46 x 95 x 73 cm (approx. 18.5 x 37.5 x 29 inches) with laptop cover down

Weight of the *Ikus*: approx. 100.6 kg (approx. 219 lbs)

#### **INSTRUCTION**

1. Place the crate with its back against a wall and/ or lock the brakes to prevent the crate from moving during loading.
2. Open the door latches and swing front door open to the left. Unlatch the ramp safety retainer and open the ramp while holding the black door panel behind the ramp.



**Fig. 6-22** Empty shipping crate



3. Make sure the laptop is closed and in parking position.

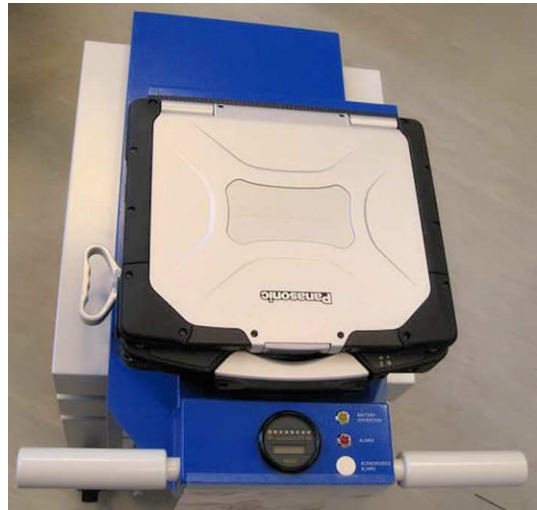

Fig. 6-23 Prepare the laptop

4. Line up the Ikus with the ramp. Push it upward on the handle bars; all the way into the crate.



Fig. 6-24 Line up the Ikus

5. Engage the Ikus front wheel brake (pushing the lever down).



6. Place the accessory box in front of the Ikus top of the bottom.



**Fig. 6-25** Place the accessory box

7. Reattach the securing plate.



**Fig. 6-26** Reattach the securing plate

8. Lift up the ramp.



**Fig. 6-27** Lift up the ramp

9. Fix the ramp with the safety retainer.



**Fig. 6-28** Fix the ramp

10. Close the front door and apply the latches.

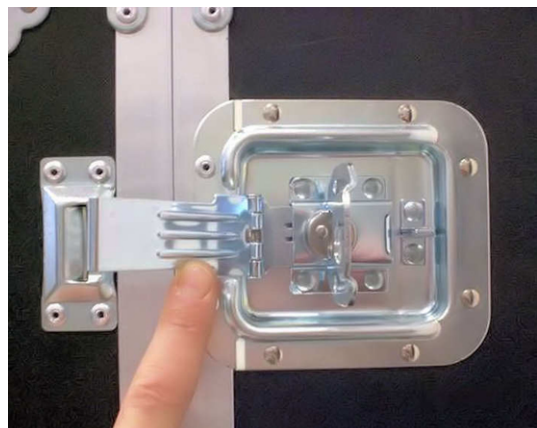

**Fig. 6-29** Close the door

11. Lock the crate with a cable binder.

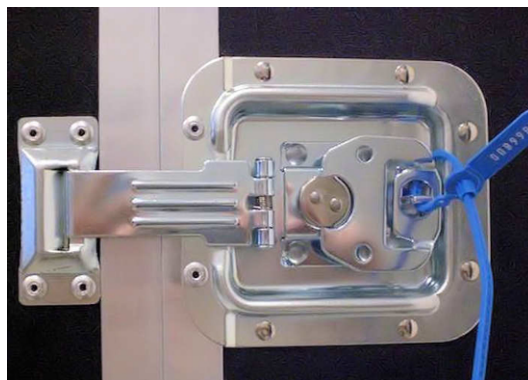

Fig. 6-30 Lock the crate

12. The crate is now ready for storage/ shipping.



Fig. 6-31 Crate ready for storage/ shipping

## 6.8 Cleaning and disinfection of the Ikus

**WARNING**

Prevent liquids from spilling into the Ikus. Otherwise there is a risk of an electric shock and of a malfunction of the Ikus.

**NOTICE**

Do not use any corrosive or colored solutions or organic solvents to clean the Ikus as they may alter the surface of the product. Ikus can be cleaned by wiping disinfection with an alcohol containing solution. Omit the air vents.

**➤ INSTRUCTION**

1. Clean Ikus by wiping disinfection with an alcohol containing solution (e.g. BacilloI® plus).  
IMPORTANT: Do not expose display and keyboard to direct spray jet, but use a cloth that is moistent with disinfecting agent.

*This page was left blank intentionally*

## 7 Commissioning the Ikus and setting parameters



Before starting the Ikus, make sure that a replacement *Ikus* is available in the hospital. If a replacement *Ikus* is not available, there is a risk that the patient cannot be cared for in the event of device malfunction.

The general rule is:

1 replacement *Ikus* if 1 or 2 systems are in use

2 replacement *Ikus* if 3 or 4 systems are in use

3 replacement *Ikus* if 5 or 6 systems are in use.

If more than 6 systems are in use the number of replacement *Ikus* has to be 1/2 of the active systems.

When switching on the system, make sure that the *Ikus* is first switched on and then the laptop and not vice versa!



Always observe a resting period of 6 hours after each transportation before switching on the *Ikus*! The temperature of the *Ikus* should get adapted to the ambient temperature.

Before putting the *Ikus* into operation, check that the ambient conditions are suitable (see section 16.2: Technical specifications, page 217).

Keep all driving tube connectors covered at all times when not in use.

### NOTICE

This chapter describes the technical aspects of commissioning the system as well as perioperative and postoperative drive management. When commissioning the system, it is vital to observe the instructions given in chapter 8: Implantation: Preparations in the operating room, page 109.

The drive management procedures described here are intended as recommendations only. There is no substitute for careful patient observation and evaluation by the appropriate medical personnel.

**IMPORTANT:** Make sure that the position of the *Ikus* always allows easy access to the mains plug.

### 7.1 Preparatory steps outside of the operating room



Switch the *Ikus* on 2 hours before its intended use in order to adequately charge the batteries and so that a start-test can be performed to detect any possible faults in the device. During this period, always connect both tank units to the *Ikus* (see section 7.1.1: Connecting the tank unit, page 94)!

The *Ikus* power switch (toggle switch) should always be in the *[I]* position, even if the *Ikus* is set to *[O]* position at the main switch (key switch)! Otherwise the driving unit may stop completely because the batteries have become fully depleted.

The **<NumLk>** and the **<Caps Lock>** key on the laptop must be deactivated. The status LED on the laptop, identified by a lock symbol and/or a numeral (e. g. 1), should not light (see Fig. 6-1, page 67 to Fig. 6-3, page 68).

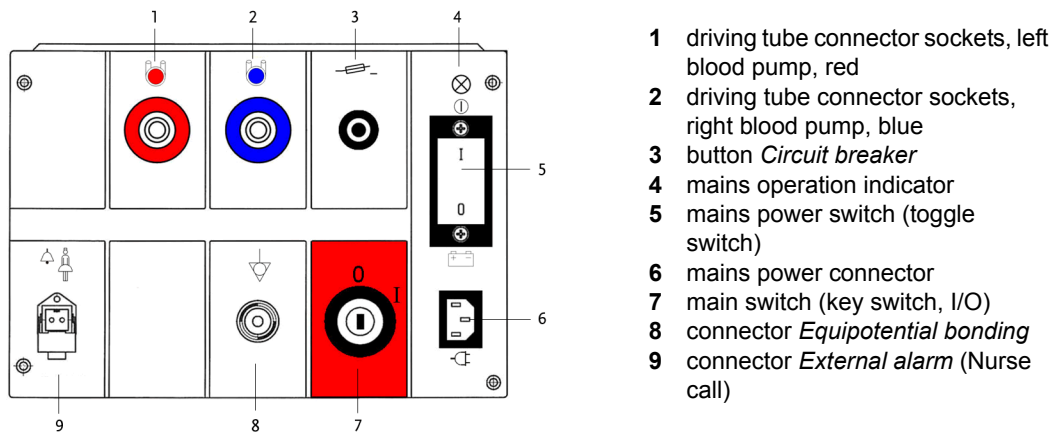

Fig. 7-1 Connection panel

### 7.1.1 Connecting the tank unit



Fig. 7-2 Tank unit

**IMPORTANT:** 2 separate tank units are used, each equipped with a driving tube.

**IMPORTANT:** The tank unit simulates a real operating situation during the warming-up period. If the test parameters have been set correctly (see section 7.1.4: Setting the test parameters, page 95), the tank units prevent the *Ikus* from generating false error messages.



**➤ INSTRUCTION**

1. Remove the seal plugs from the driving tube connection socket.
2. Connect the plug of the 2 tank units to the driving tube connection sockets.

**7.1.2 Switching on the Ikus****⚠ WARNING**

The *Ikus* must always be connected to the power supply when it is switched on. This is the only way to ensure that the start-up test (see section 7.1.3: Starting the monitor program, page 95) is performed completely and possible malfunctions can be detected.

**⚠ CAUTION**

When switching on always take care to switch on the *Ikus* first and then the laptop. Never vice versa!

**➤ INSTRUCTION**

1. Connect the *Ikus* to the mains. Secure the mains cable with the plug clip. Ensure that the mains power switch (toggle switch) is set to *[I]* position.
2. Turn the main switch (key switch) to the *[I]* position. The battery charge indicator will light up and the number of hours the driving unit has been operated will be displayed. The mains operation indicator lights up.
3. The menu *Select language* appears after the laptop is switched on.
4. Select the desired language by pressing the corresponding number key. It is not necessary to press **<Enter>** to confirm this selection.
5. The start menu is displayed on the laptop.

**7.1.3 Starting the monitor program****➤ INSTRUCTION**

1. Select the **1. Start program** option (**<1>**) in the start menu.
2. Enter user ID and password, confirm with **<Enter>**. The *Ikus* will carry out a start-test.
3. Wait for the start-test to finish (it takes several minutes). Do not mute the acoustic signal by pressing the *Mute button*. Exception: an error message is displayed. The messages in the message window will provide information on the status of the test. If the *Ikus* is found to be operating correctly, the view *Select operating mode* will be displayed next.

**7.1.4 Setting the test parameters****NOTICE**

When delivered, the *Ikus* has standard default parameters that it uses after each complete start-up process (see section 6.5.1: Routine start-test when not in operation, page 83 and section 15.3.2: *Ikus* start-test following emergency pulse mode, page 201). However, during the warm-up period with the tank unit, it is necessary to set the test parameters to prevent the *Ikus* from generating a false error message.

Systole [mmHg] left/right	Diastole [mmHg] left/ right	Rate [bpm]	Rel. systole duration [%] left/right	Operating type/mode
200	0	70	40	biventricular, synchronous mode

Tab. 7-1 Test parameters

**➤ INSTRUCTION**

1. Even with planned univentricular operation: navigate the cursor to **Biventricular (BVAD)**, confirm with **<Enter>**. The view *Pump size and single-step mode* appears.
2. Place the cursor with **<↑>** in the parameter table and navigate with **<←>/<→>** to the desired field in the parameter table. Adjust the value with **<↓>, <↑> / <Bild-↓>, <Bild-↑>**, then confirm with **<Enter>**.
3. Check that the batteries are sufficiently charged.
4. Disconnect the plug from the power supply and bring the Ikus immediately into operating room. Either acknowledge the message (**Battery operation**) on the laptop or mute it by pressing the button *Mute alarm* on the operating panel.
5. In operating room: Reconnect the *Ikus* to the power supply.

**If Ikus has detected a fault**

**NOTICE** An overview of the messages that might occur during the start-test is given in section 14.25: Error messages during the start-up test, page 187.

The display **FAULT** in the parameter table indicates that the start-test has detected a fault. Such faults may be caused, for instance, by operating errors when the system was last shut down or during the start-up procedure.

**➤ INSTRUCTION**

1. Shut down the monitor program as instructed in the dialog window.
2. Use the main switch (key switch) to switch off the Ikus. IMPORTANT: The mains power switch (toggle switch) remains set to **[I]** position.
3. Wait for at least 10 minutes.
4. Commence the start procedure again (see section 7.1.3: Starting the monitor program, page 95).

**If Ikus detects a fault again:**

Do not use this Ikus.

**HOTLINE** Notify Berlin Heart! 866.249.0128

## 7.2 Intraoperative drive management

### 7.2.1 Disconnecting the tank unit from the Ikus

#### ➤ INSTRUCTION

1. Select **Drive pause** then press **<Enter>** to confirm. Confirm the decision in the dialog window by pressing the **<X>** key or the **<1>** key. The Ikus will stop. The view *Select operating mode* is displayed.
2. Disconnect both tank units from the *Ikus*.
3. Seal the driving tube connection sockets with seal plugs.

### 7.2.2 Selecting the operating mode (view *Select operating mode*)

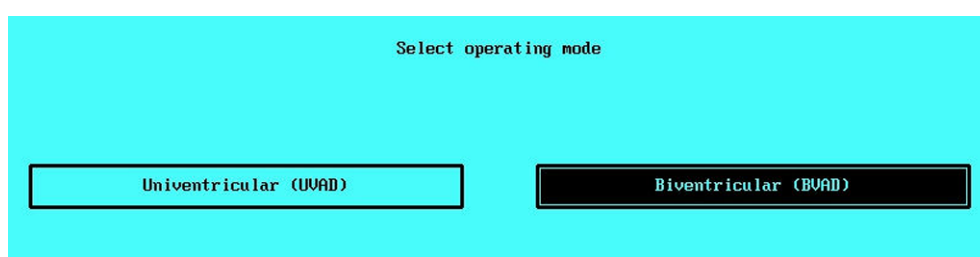

Fig. 7-3 Select operating mode

#### ➤ INSTRUCTION

1. In the operating room the *Ikus* should be reconnected to the mains immediately.
2. Select **Univentricular (UVAD)** or **Biventricular (BVAD)** with cursor, then confirm the selected operating mode with **<Enter>**.
3. In biventricular mode: the view *Pump size and single-step mode* appears (see Fig. 7-7, page 100).  
In univentricular mode, a connector seal test is first performed: the Ikus checks whether the driving tube connector socket with the blue marking has been sealed.

#### Univentricular operation: connector seal test

##### NOTICE

The Ikus will repeat the connector seal test up to 3 times. If the test is still not successful, the system will switch itself off. Please contact the emergency hotline.

##### HOTLINE

**Notify Berlin Heart! 866.249.0128**

#### ➤ INSTRUCTION

1. The message **Please close right outlet** is shown. Check the driving tube connector identified by a blue marking. If the connector is open: use the seal plug to close it.
2. Move the cursor to **OK** and press **<Enter>** to confirm. The *Ikus* will test whether the connector is properly sealed. If it is, the view *Pump size and single-step mode* is displayed. If not, the *Ikus* will repeat the connector seal test.

### 7.2.3 Select the pump size

**NOTICE**

It is not possible to select a larger blood pump and/or a higher rate for the right pump than for the left one. The list of pump sizes available for the right pump is limited accordingly.

The sizes written in red ink in the pop-up menu *Select pump size* can be chosen. However, they are not the recommended option for each individual case (see Fig. 7-4, page 98).

In individual cases, consideration is to be given as to whether a combination that is not recommended is to be selected. The final decision on the combination of blood pumps and cannulae is to be reached by the implanting surgeon, in consultation with Berlin Heart, Inc., Clinical Affairs.

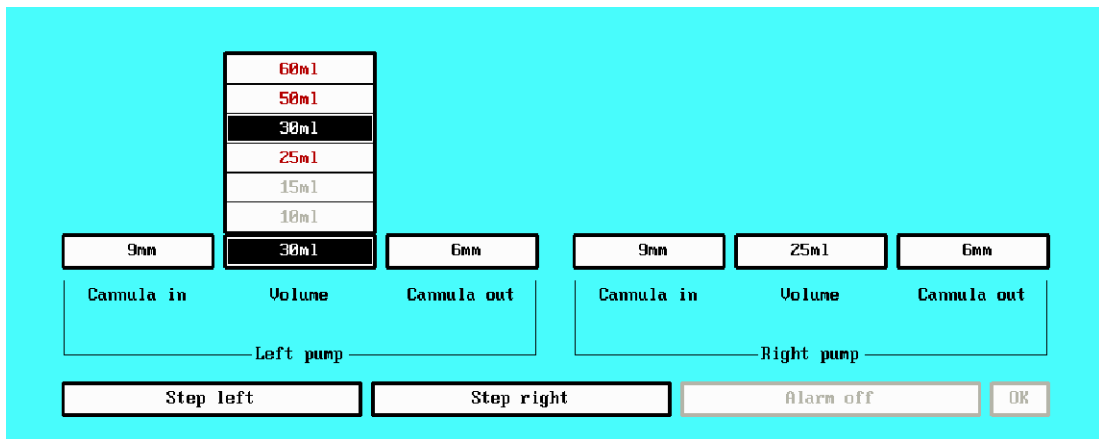

Fig. 7-4 Select the pump size

**INSTRUCTION**

1. In the pop-up menu, select the desired pump size with <↓>/ <↑> .
2. In biventricular mode: Using the cursor keys <←>/<→> , move to the field marked right pump, select the desired pump size with the cursor keys <↓>/ <↑>.

### 7.2.4 Select the cannula size

**NOTICE**

The sizes written in red ink in the pop-up menu *Select the inflow and outflow cannula sizes* can be chosen. However, they are not the recommended option for each individual case (see section 16.1.10: Maximum rates for the pump-cannula combinations, page 216 and section 16.1.11: Blood pump combinations in biventricular mode, page 217). In individual cases, consideration is to be given as to whether a deviant combination is to be selected. The final decision on the combination of blood pumps and cannulae is to be reached by the implanting surgeon, in consultation with Berlin Heart, Inc., Clinical Affairs.

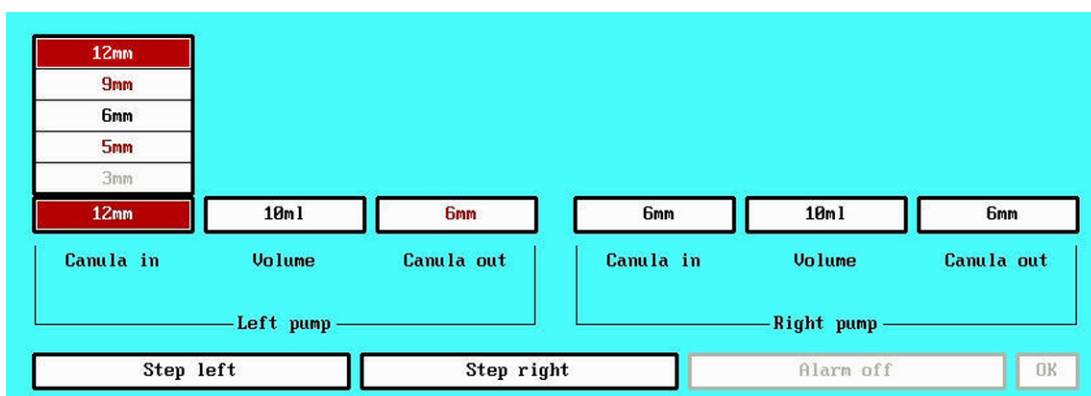

Fig. 7-5 Cannula in for the left pump

#### ► INSTRUCTION

1. From the pop-up menu **Cannula in** for the left pump, select the inflow cannula size for the left pump with <↓>, <↑>.
2. Move cursor with <←>/<→> to the pop-up menu **Cannula out** for the left pump. With <↓>, <↑> select the outflow cannula size for the left pump.
3. In biventricular mode: Move the cursor with <←>/<→> to the pop-up menu **Cannula in** for the right pump, select cannula size with <↓>, <↑>.
4. Move cursor with <←>/<→> to the pop-up menu **Cannula out** for the right pump. With <↓>, <↑> select the outflow cannula size for the right pump.

### 7.2.5 Display pump and cannula sizes

It's possible to display the selected pump and cannula sizes on the laptop screen.

#### ► INSTRUCTION

1. Press <F10> to shut down the monitor program. Confirm the decision in the dialog window by pressing the <X> key or the <1> key.
2. The start menu is displayed.
3. In the start menu, select the option **1. Start program** (<1>).
4. Enter user ID and password, confirm by pressing <Enter>.
5. In the message window the selected pump and cannula sizes are displayed.



Fig. 7-6 Display pump and cannula sizes

### 7.2.6 Setting the start-up parameters



To connect the blood pump(s), always set the start-up parameters!

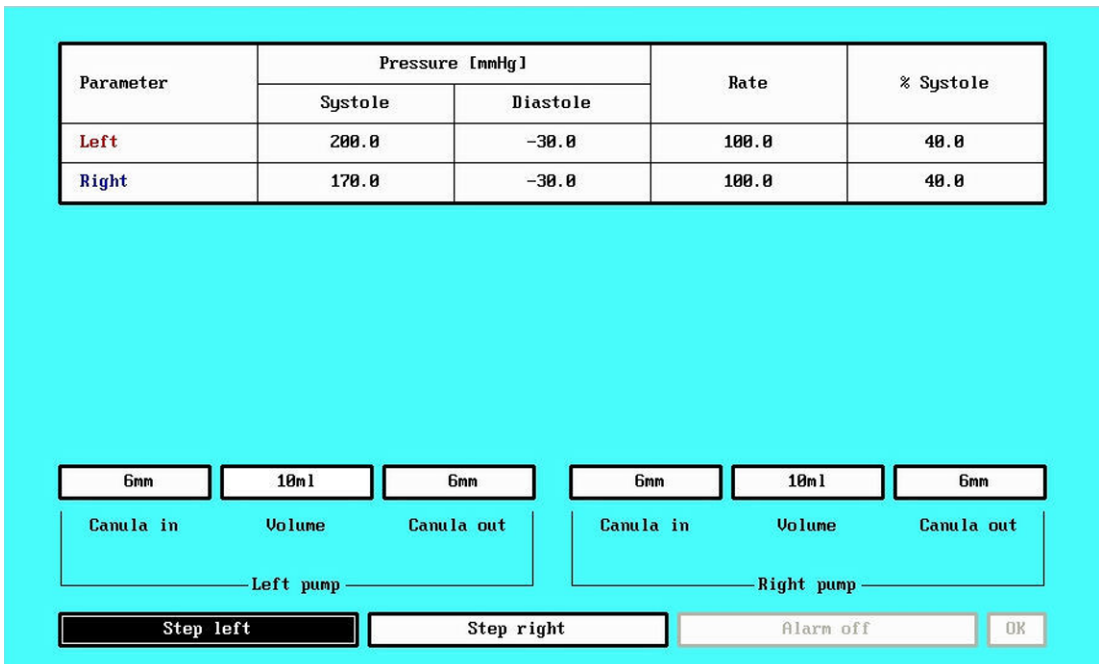

Fig. 7-7 Pump size and single-step mode

**➤ INSTRUCTION**

1. Place the cursor with <↑> in the parameter table and navigate with <←>/ <→> to the desired field in the parameter table. Adjust with <↓>, <↑> /<Bild-↓>, <Bild-↑> then confirm with <Enter>.
2. Set the start-up parameters:

Systole [mmHg] left/ right	Diastole [mmHg] left/ right	Rate [bpm]	Rel. systol. duration [%] left/ right
100/ 80	-5/-5	30	40/40

Tab. 7-2 Start-up parameters

**7.2.7 Connecting the blood pump(s) to the Ikus****⚠ WARNING**

Do not kink either the driving tubes or the cannulae.

**NOTICE**

State of the blood pumps when they are initially connected: filled with sterile injectable saline, de-airing needle in place. To allow easier handling, the driving tubes are not connected until the inflow and outflow cannulae have been connected to the pump (see section 9.9: Connecting the blood pumps to the cannulae, page 128).

**➤ INSTRUCTION**

1. Open the driving tube connector marked in red (univentricular) or both connectors (biventricular). To do so, pull the seal plugs out of the connector(s).
2. Connect the driving tube to the Ikus. To do so, push the plug of the driving tube into the connector. The sound of the plug snapping into place is clearly audible. Check that the plug is securely connected. To do so, grip the plug body above the release sleeve and pull on it. Do not pull from the release sleeve, and never from the tube!
3. In biventricular mode: observe the color of the markings.
4. In biventricular mode: repeat the procedure for the second pump.

Operating mode	Ikus connector
biventricular	LVAD: connector marked red RVAD: connector marked blue
univentricular	connector marked red

Tab. 7-3 Assignment: operating mode, blood pump, connector

### 7.2.8 De-airing the blood pumps in single-step mode

**NOTICE**

Each de-airing step (**Step left/ Step right**) carries out half a pump cycle (systole or diastole), the 1<sup>st</sup> step being a diastole. Normally, several de-airing steps are required for each pump. In single-step mode, the pumps will operate using the pressures shown in the parameter table. It will not be possible to switch to the standard view unless at least 1 de-airing step has been completed for each connected pump.

**INSTRUCTION**

1. Bring the patient into the Trendelenburg position.
2. Move the cursor to the field marked **Step left**.
3. Lift the pump. The de-airing nipple is the highest point.
4. To trigger a single step, press the **<Enter>** key. If necessary, use the de-airing needle to vent the air from the pump (see section 8.5: De-airing the blood pump, page 112). After consulting the surgeon: If necessary, press **<Enter>** repeatedly to trigger further single steps until all air has been removed from the pump(s). If the blood pump is not filling sufficiently, ensure there is sufficient preload and if necessary, increase the diastolic pressure.
5. In biventricular mode: Move the cursor to the field **Step right**. Repeat the procedure for the 2<sup>nd</sup> pump.

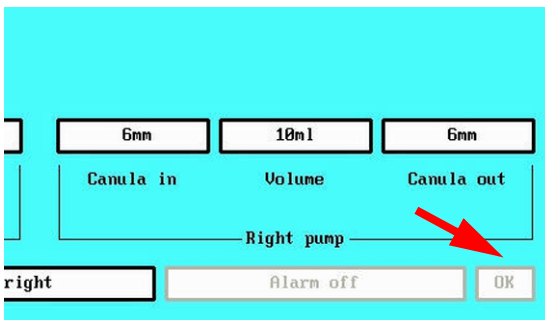

Transition to continuous pumping mode is not yet possible because **OK** field is still inactive.

Fig. 7-8 Single-step mode

### 7.2.9 Starting the blood pump (changing to standard view)

**WARNING**

Do not start the pump(s) until all air has been removed.

Once the de-airing needle has been removed it cannot be re-inserted.

Only remove the de-airing needle after all air has been removed from the blood pump, the blood pump is running and the parameters have been adjusted (see section 7.2.10: Checking the parameters when the pump is started and adjusting them, page 103 and section 9.10: Removing the de-airing needle, page 130).

**INSTRUCTION**

1. Move cursor to the **OK** field and press **<Enter>** to confirm. The system now starts with the parameter values visible in the parameter table.



## 7.2.10 Checking the parameters when the pump is started and adjusting them

### **WARNING**

In order to avoid air being sucked into the blood pump through the cannula anastomosis, adjust the parameters gradually. If air does enter the system, disconnect the driving tubes from the Ikus and de-air the system using the de-airing needle.

Continuously monitor all settings.

Once the de-airing needle has been removed it cannot be re-inserted.

### **NOTICE**

If the pump is not filling adequately at this stage, increase the preload by adding volume from the CPB circuit. After adding volume, adjust the parameters on the laptop of the *Ikus* as described in the following table.

### **INSTRUCTION**

1. Observe the left blood pump. Is the pump ejecting completely? If not: increase the left driving pressure if necessary.
2. Observe the right blood pump. Is the pump ejecting completely? If not: increase the right driving pressure if necessary.

Observe	Action / measure
Right pump Is the pump filling properly? (see below)	If not: check the filling pressure (central venous pressure; CVP) CVP too low: substitute volume CVP too high: increase suction pressure If no improvement occurs: check the position of the cannulae via echographic monitoring!
Left pump Is the pump ejecting properly?	If not: check mean arterial pressure (Guideline value: 70mmHg)
Compare left and right pump. Is left pump filling considerably worse than right pump?	If yes: increase suction pressure on left side If no improvement occurs: check the position of the cannulae via echographic monitoring!

Tab. 7-4 Pump filling criteria

**Keep the following points in mind with regard to filling of the right pump:**

The aim is to reduce the right ventricle’s load to a large extent but not completely. Signs that the RV load has been reduced completely are:

- filling of the pump depends largely on the respiratory cycle
- ventricle is empty/limp
- membrane stops abruptly during filling

IMPORTANT: If the three above-mentioned phenomena are observed, do one of the following:

- reduce the diastolic pressure
- substitute volume

**Adjusting parameters**

**➤ INSTRUCTION**

1. Use the <←>/<→> keys to move the cursor to the desired field in the parameter table. The selected field is given a colored background.
2. Use the <↓>,<↑> or <Bild-↓>, <Bild-↑> keys to adjust the value, then press <Enter> to confirm the input.

Parameter	Range possible	<↓>/<↑> changes value by	<Bild-↓>/<Bild-↑> changes value by
Systolic pressure [mmHg]; driving pressure	60 to 350	2.5	25
Diastolic pressure [mmHg]; suction pressure	0 to -100	2.5	25
Rate [bpm]	30 to 150	1	10
Relative systolic duration [%]	20 to 70	1	10

Tab. 7-5 Parameter’s possible adjustments

**In biventricular operation: adjusting the operating mode**

To run the pumps in the asynchronous mode or separate mode instead of the synchronous mode the appropriate mode must be selected.

- asynchronous mode is recommended for patients who have a small thorax volume in comparison to the pump volume. In asynchronous mode, the intrathoracic blood volume remains unchanged.
- separate mode is useful, under some circumstances, for patients with intracardiac shunts.

**INSTRUCTION**

1. Use the <←>/<→> keys to move the cursor to the field showing the current operating mode. A pop-up menu showing the available operating modes is opened (see Tab. 7-3, page 101).
2. Select the desired operating mode with <↓>, <↑> and confirm with <Enter>. The system will now work in the selected mode.

**Guideline values**

The most important criteria when selecting drive parameters is that they ensure a good filling and emptying of the pump; the parameters must be set to achieve this goal.

**NOTICE**

The systolic driving pressure must be higher than the patient's physical systolic pressure. **IMPORTANT:** If the systolic duration (% systole) is reduced or if very small cannulae are used, it may be necessary in some cases to select a higher value than recommended here.

The actual driving pressures achieved are influenced by the diameter of the cannulae used.

The following values are merely guideline values; they may not be appropriate in each individual case

Systolic pressure [mmHg], left/ right	Diastolic pressure [mmHg], left/ right	Rate [bpm]	Rel. systolic duration [%], left/ right
220/150	-40/-40	80	40/40

**Tab. 7-6** Recommended guideline values for normal operation

**ADVICE**

Remove the de-airing needle after all air has been removed from the blood pump, the blood pump is running and the parameters have been adjusted (see section 7.2.10: Checking the parameters when the pump is started and adjusting them, page 103 and section 9.10: Removing the de-airing needle, page 130).

**IMPORTANT:** Once the de-airing needle has been removed it cannot be re-inserted.

**7.2.11 Switching from CPB support to VAD support**

The aim here is to reduce the CPB flow and in doing so to shift the volume from the CPB to the patient (i.e. to the VAD)

**WARNING**

Secure the driving tubes and cannulae to the blood pump(s) as soon as the proper function of the EXCOR is established (see section 9.11: Securing the connections, page 130).

**➤ INSTRUCTION**

1. When the blood pump(s) starts to fill, reduce the CPB flow and gradually increase the EXCOR rate from an initial 30 bpm until CPB has been terminated and the required flow is achieved. **IMPORTANT:** In doing so, make sure that the pump fills adequately, and if necessary regulate the driving pressure.
2. If necessary, adjust the systolic pressure, diastolic pressure and the systolic percent.

### 7.2.12 Possible complications

#### Decreased filling after stable filling conditions

If a good filling behavior was achieved at first (filling pressures LA/CVP < 10 mmHg and diastolic pulmonary artery pressure < 15 mmHg) with good drainage and nominal rate (normally 80 bpm), but the filling has deteriorated over time, it usually will not help to increase the diastolic pressure.

Deterioration in the filling behavior despite stable inflow conditions may indicate hypovolemia or obstruction of the inflow cannula. The cause of deterioration in filling behavior must be identified and addressed.

**NOTICE** Manipulations during implantation can severely influence the inflow temporarily – wait for the situation to stabilize before adjusting the values.

**➤ INSTRUCTION**

1. Evaluate volume status and transfuse if necessary. Evaluate and if necessary correct the cannula position.

#### Pump filling deteriorates when thorax is closed

If atrial cannulation is used, a slight decrease in the filling may be observed in some cases when the thorax is closed. This may be caused by compression of the atria or a slight shift in the position of the cannulae.

**➤ INSTRUCTION**

1. Evaluate volume status and transfuse if necessary. **IMPORTANT:** Observe the effect volume replacement on the pump filling!
2. Increase suction pressure.

#### Distinct decrease in filling or generally poor inflow conditions on right side

**➤ INSTRUCTION**

1. Make sure that there is no inflow obstruction.
2. If a suction pressure of less than -50 mmHg is necessary, increase the relative diastolic duration as an additional measure. At the same time, the systolic duration is reduced accordingly. **IMPORTANT:** Increase the driving pressure accordingly!

**Incomplete ejection right/left****► INSTRUCTION**

1. Observe the arterial blood pressure, and at the same time observe the ejection movement of the pump membrane.
2. If complete emptying of the pump is no longer achieved, adjust the driving pressure accordingly. **IMPORTANT:** Do not respond to extreme – temporary – increases in the arterial blood pressure (due to manipulation, catecholamine, etc.).

**7.3 Postoperative drive management****NOTICE**

---

The patient should receive the same treatment as is usual after any other major cardiac surgical procedure.

---

**7.3.1 After transfer to the ward**

If a good filling and stable ejection of the blood pump(s) is observed in the immediate post-operative period, it is normally not necessary to adjust the driving and suction pressures.

- Good filling means that the suction pressure is adequate.
- Stable ejection (at normal arterial blood pressure) means that the driving pressure is adequate.

**⚠ WARNING**

---

At least every 4 hours, visually check that the pump(s) is (are) filling and ejecting completely over a period of several pump cycles. If a pump is not filling and/ or ejecting completely, appropriate measures are to be taken.

---

**NOTICE**

---

For further details on regular monitoring of pump(s) and cannulae, see section 11.5: Regular checks of blood pump(s) and cannulae, page 141.

---

**7.3.2 Follow-up treatment**

Guideline values and criteria for adjusting the parameter settings: see Tab. 7-6, page 105.

It is only necessary to adjust the left driving pressure when

- the arterial blood pressure increases (e. g. after lifting sedation, when the patient wakes up)
- when the patient is mobilized (moving to an upright position, sitting, standing – in order to compensate for the additional hydrostatic pressure component).

*This page was left blank intentionally*

## 8 Implantation: Preparations in the operating room

### 8.1 Preparing the components and materials required

---

**NOTICE**

Selection of blood pump(s): see section 16.1: Overview: Product range and possible combinations, page 211.

---

**ADVICE**

It is advantageous to provide a sterile table on which to place the prepared sterile components.

---

#### General (all sterile)

- 500 ml sterile injectable saline
- 2 small sterile basins
- 50 ml disposable syringe with luer lock connector
- suture (to secure the trocar to the de-airing nipple and the de-airing tube to the trocar)
- heavy scissors
- towel clamp, tube clamp
- other instruments and equipment as required for open-heart surgery

#### EXCOR components and accessories

- blood pump(s), each with a pump seal
- 1 driving tube for each blood pump
  - univentricular: driving tube, red
  - biventricular: 1 red driving tube and 1 blue driving tube
- inflow cannula(e) (atrial or LV apex cannula)
- outflow cannula(e)
- accessory set (T00L-002) for blood pumps with PU valves
  - membrane set
  - de-airing set (2 x trocar, 2 x de-airing tube)
  - de-airing hammer
  - tube connecting set (cable ties, cable-tie gun)

### 8.2 Checking and adjusting the settings of the cable tie gun

Before using the cable tie gun contained in the EXCOR *Tube connecting set* the accuracy of settings has to be checked and if necessary to be corrected.



**Fig. 8-1** Cable tie gun

**INSTRUCTION**

1. Check if the following values are set:
  - coarse adjustment on STD (2)
  - fine adjustment on 5 (1)



**Fig. 8-2** Checking the adjustment

2. In the case of deviations loosen the screw (4) and disassemble the locking cap (3).



**Fig. 8-3** Disassemble the locking cap



- Adjust the above-mentioned values with the adjusting wheels (6 and 5). Begin with adjusting wheel 6.



Fig. 8-4 Adjusting the settings

- Assemble the locking cap (3) and secure it with the screw (4).



Fig. 8-5 Assemble the locking cap

### 8.3 Unpacking the sterile components

#### **WARNING**

Only use sterile components which have been delivered in undamaged sterile condition (sterile packaging intact, expiration date not expired).

Only use blood pumps which have an undamaged aluminum-coated outer packaging.

#### **INSTRUCTION**

- Pump: a non-sterile person opens the aluminum-coated package and removes the pump in its double sterile packaging.
- The non-sterile person opens the outer sterile package.
- A sterile person takes out the inner sterile package, opens it and places the components on the prepared sterile field.

## 8.4 Moving the membrane to the end-of-diastole position



- 1 de-airing nipple (blood chamber)
- 2 driving tube connector (air chamber)

Fig. 8-6 De-airing nipple and driving tube connector

### ➤ INSTRUCTION

1. Pick up adapter tube, disposable syringe (membrane set) and the pump.
2. Connect the adapter tube to the disposable syringe.
3. Connect the free end of the adapter tube to the driving tube connector of the blood pump.
4. Remove all air from the air chamber of the pump. The blood pump membrane is now in the end-of-diastole position.
5. Seal the adapter tube with a tube clamp in order to keep the membrane in this position.

## 8.5 De-airing the blood pump



Make sure that no particles or liquids enter the air chamber of the blood pump. Otherwise, the membrane may be damaged and the patient may not receive adequate support.

### Prepare and place the following ready for use:

- blood pump(s) with pump seal(s)
- 1 de-airing set (trocar and a de-airing tube) for each blood pump
- 50 ml disposable syringe for each blood pump

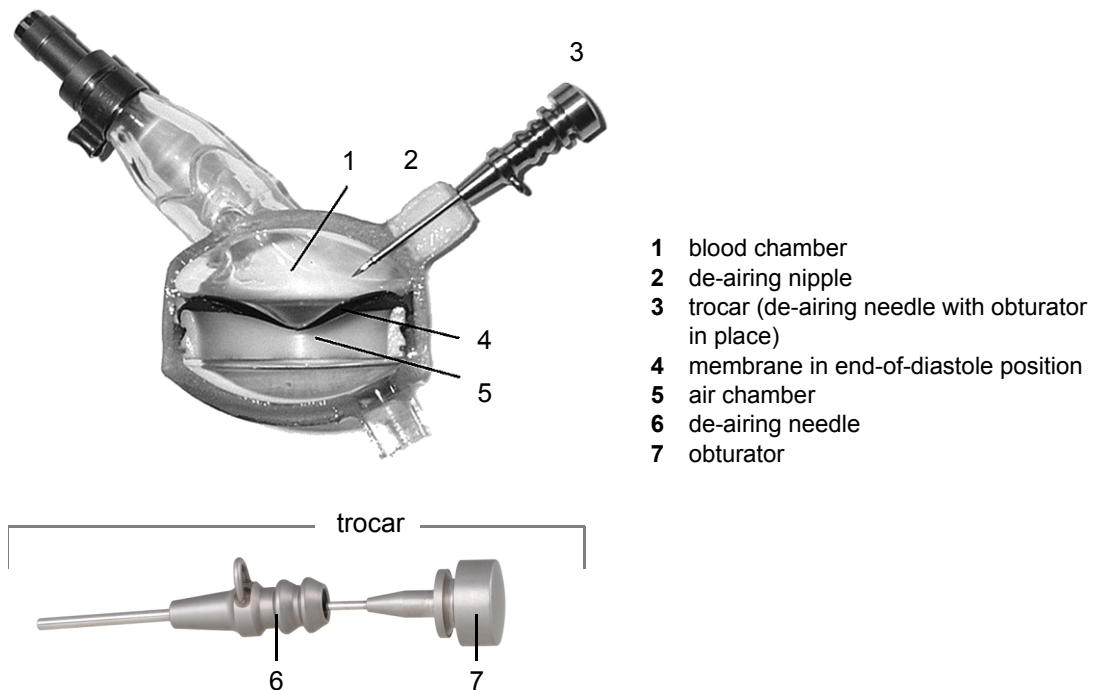

Fig. 8-7 Pump with trocar in place (de-airing needle with inserted obturator)

### 8.5.1 Inserting the de-airing needle



#### WARNING

The membrane must be kept in the end-of-diastole position. Keep the clamped membrane set connected to the blood pump.

#### INSTRUCTION

1. Take hold of the trocar (de-airing needle with obturator) and remove the protective silicone cap.
2. Push the trocar as pictured above as far as it will go through the center of the blood pump's de-airing nipple. Never turn the trocar when inserting it, this increases the risk of removing a large piece of the silicone material in the de-airing nipple.
3. Remove the obturator.
4. Withdraw the de-airing needle by approx. 2 mm. **IMPORTANT:** The tip of the cannula should still be visible in the blood chamber.
5. Use the suture to fix the de-airing needle to the de-airing nipple.
6. Remove the adapter tube from the pump.

### 8.5.2 Rinsing and filling the blood pump



#### ADVICE

Before commencing surgery, mark the points for the exit sites of the cannulae. The aim is to achieve a stable final position of the cannulae without exerting any tension on the skin. Caution: with biventricular support, 2 of the 4 cannulae will cross each other. This crossing point should be outside of the thorax as far as possible.

Fill and empty the pump once or twice with sterile injectable saline:

**➤ INSTRUCTION**

1. Push the free end of the de-airing tube onto the trocar as far as it will go. Secure the de-airing tube to the trocar with a suture tie.
- 2.
3. Fill the syringe with sterile injectable saline.
4. Connect the syringe to the stopcock end of the de-airing tube.
5. Slowly fill the pump with sterile injectable saline. Rock the pump back and forth to move any bubbles to the outflow stub.
6. Close the stopcock on the de-airing tube.
7. Tap the blood pump body gently in order to free all remaining bubbles. Remove all air from the pump through the outflow connector.
8. Use the seal caps to close the titanium cannula connectors.
9. Place the pump ready for connection with the connectors pointing up.

## 9 Implantation - surgical procedure

This chapter describes the product-specific measures to be observed when implanting an EXCOR blood pump. The setting of the *Ikus* parameters during and after implantation is described in chapter 7: Commissioning the *Ikus* and setting parameters, page 93. If the *Ikus* is brought into the OR, the *Ikus* should be prepared as described in section 7.1: Preparatory steps outside of the operating room, page 93.

Unless any specific instructions to the contrary are given, the same protocol as for any other major cardiothoracic surgical procedure should be followed. Implantation is accomplished using a CPB with bicaval cannulation. Implantation can be achieved with induced ventricular fibrillation or on a beating heart, hypothermia is usually not required.

### WARNING

---

After implantation each cannulae and all connections must be inspected for its solidity, safeness and tightness.

---



---

Do not start pump operation until the blood pump is completely free of air!

---



---

Do not touch or manipulate the blood pump with pointed or sharp-edged objects (e. g. surgical instruments)!

---



---

Do not touch or manipulate the drive lines with pointed or sharp-edged objects (surgical instruments, wire brushes, etc.), otherwise these components could be damaged.

---



---

If a cannula is bent with flexible metal reinforcement to adjust it to the anatomical conditions: determine by visual inspection that the blood flow in the cannula is not restricted.

---



---

When positioning the driving tubes mitigate the risk of adverse tubing and line incidents by routing the driving tubes in a clear pattern toward the feet and to the side.

---



---

When using blood pumps of equal size on the left and right, verify that the pulmonary circulation is not being overloaded. Otherwise, pulmonary edema may result.

---

### NOTICE

---

For the suture use an appropriate suture material. It should be a nonabsorbable monofilament, not traumatizing material.

---

**ADVICE**

For BVAD, carry out anastomosis of the cannulae in the following order:

**apical cannulation:**

1. LV apex
2. right atrium
3. pulmonary artery
4. aorta

**atrial cannulation:**

1. left atrium
2. right atrium
3. pulmonary artery
4. aorta

## 9.1 Cannula exit sites

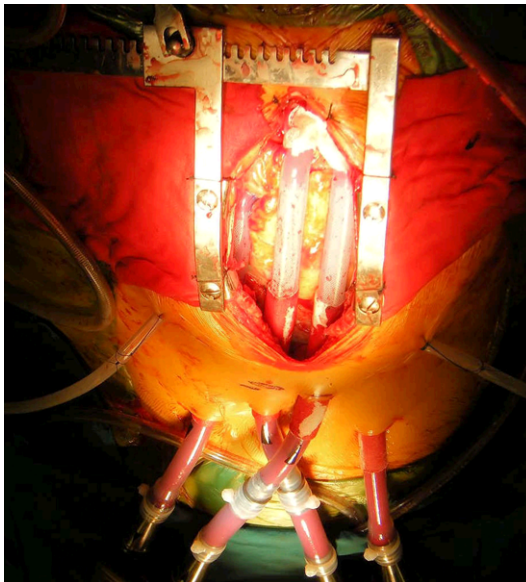
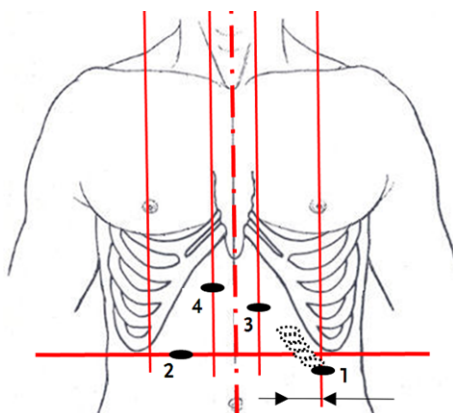

Fig. 9-1 Cannula position following implantation



- 1 Aortic cannula
- 2 PA cannula
- 3 RA cannula
- 4 LV apex cannula

Possible exit site for LV apex cannulation (depending on the size of the patient's heart)

Fig. 9-2 Suggested cannulae exit sites (Example: BVAD with LV apex cannulation)

## 9.2 Use of the cannula tunneling tip

The cannula tunneling tip is a sterile disposable product and is supplied with each cannula. Sizes available: see section Fig. 9-3: Available sizes of cannula tunneling tips, page 117. Staged cannulae are supplied with 2 different tunneling tips.

### ➤ INSTRUCTION

1. Push the cannula tunneling tip firmly into the distal end of the cannula.
2. Advance the forceps through the subcostal incision and the cannula tunnel into the mediastinum, so that the cannula tunneling tip can be gripped.
3. Use the forceps to firmly grip the flat end piece, pull it through the cannula tunnel and the skin incision and position it.
4. Carefully remove the tunneling tip from the cannula by bending it back and forth.

Refer to the respective cannula type as described in section 9.3: Cannulae, cannula extension set and connecting set, page 117 to section 9.7: Arterial cannula(e), page 126 of the instruction for use to determine the sequence of cannulae anastomosis and tunneling.



Fig. 9-3 Available sizes of cannula tunneling tips

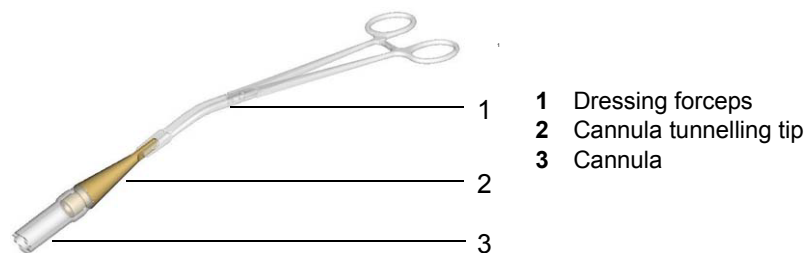

Fig. 9-4 Use of cannula tunneling tip

## 9.3 Cannulae, cannula extension set and connecting set

To avoid damages of cannulae careful attention should be paid to the following safety precautions.

The use of the cannula extension set / of the connecting set involves further safety precautions. See section 9.3.2: Instructions for Use: Cannula extension set and connecting set, page 119.

### ⚠ WARNING

The Cannula Tunneling Tip (provided with each cannula) should be used during implantation of the EXCOR system.

---

If it is necessary to apply a clamp directly to the cannula in order to pull the cannula through the skin, the following procedures should be observed:

- Position the clamp at the distal end of the cannula
  - After the cannula has been pulled through the skin, cut off and discard the part of the cannula where the clamp was applied.
- 

If it is necessary to clamp any other part of the cannula (cannula extension set / connecting set resp.) that is not covered with velour, cover the part that will be clamped with a gauze sponge.

---

If replacement of an EXCOR blood pump is required, the following procedures should be observed:

- The cable tie covering the EXCOR cannula on the stub of the blood pump should be removed carefully. Use an appropriate blunt tool. **IMPORTANT:** never use a sharp instrument, for example, a scalpel or scissors, to remove the cable tie. This may cause damage to the cannula.
  - If a cannula extension set/ connecting set needs to be cut for a pump replacement, ensure that there will be sufficient length of the tube part remaining to meet the minimum length recommendations. See Tab. 9-1, page 120.
- 

Do not kink the drivelines. Otherwise there might not be sufficient pump output

---

Do not kink the cannulae needlessly. Otherwise there might not be sufficient pump output. Moreover, cannulae might be damaged.

---

At least daily, the EXCOR cannulae should be inspected for signs of wear or damage. **ADVICE:** To avoid needless kinking of the cannulae use a mirror for inspection of the bottom side of the blood pump.

---

In no case should the cannulae either be kinked directly at the connector to the blood pump or at the transition area between velour and silicone.

---

### **9.3.1 Description: Cannula extension and connecting sets**

Berlin Heart supplies connecting sets to bridge different connector diameters in the blood pump and cannula (6/9, 9/12). This allows for greater flexibility when combining blood pumps and cannulae. The connecting set may be used during implantation or during the further course of therapy.

Berlin Heart supplies cannula extension sets for blood pumps/cannula combinations with diameters of 6/6, 9/9 and 12/12.

The cannula extension set is used to lengthen the piece of cannula which remains after the cannula has been shortened.



These sets could be necessary in the following contexts:

- during implantation
- when replacing a blood pump
- when cutting off a piece of cannula (due to visible deposits or damaged cannula)

The cannula extension set / connecting sets thus guarantee that the blood pump and cannulae can still be safely connected with one another and that the cannulae and titanium connectors on the blood pump can still be visually inspected.

Each cannula extension set / connecting set consists of two cannula extensions / connectors. Each cannula extension / connector comprises a double-sided titanium connector to which a piece of tube is connected on one side.



Fig. 9-5 Cannula extension: titanium connector with tube section

### 9.3.2 Instructions for Use: Cannula extension set and connecting set

#### Cannula extension set



**WARNING**

If, on *further shortening* of the cannula, visual inspection of the titanium connector on the blood pump is no longer possible: use the cannula extension set.

#### Cannula extension set and connecting set



**WARNING**

The cannula extension set and the connecting set should only be used if necessary, since the basic risk of thrombogenesis and deposits increases each time the cannula is extended.

Do not combine the connecting set with stage cannulae in such a way that multiple diameters are bridged. Otherwise, the pump will not fill or empty completely.

Secure each of the connections with at least 1 cable tie. Otherwise, the connections may loosen over time and the cannula extension set / the connecting set may become separated from the blood pump.

All effort should be made to minimize the manipulation and distortion of the blood pumps and cannula during the removal of the cable tie(s) to prevent mobilization of deposits.

If it is necessary to clamp any other part of the cannula (cannula extension set / connecting set resp. ) that is not covered with velour, cover the part that will be clamped with a gauze sponge

When using a cannula extension set / a connecting set it may be necessary to shorten the respective connecting tube, but the minimum length must be maintained. See Tab. 9-1, page 120.

Article	Diameter / Diameter reduction	Minimum length
<b>Cannula extension set</b>		
A06-006	6 mm	55 mm
A09-009	9 mm	60 mm
A12-012	12 mm	75 mm
<b>Connecting set</b>		
A06-009	9 to 6 mm	60 mm
A09-012	12 to 9 mm	75 mm

**Tab. 9-1** Cannula extension set / connecting set: minimum length of tube section

Ensure that the cannulae are no longer than necessary for the purposes of therapy. Shorten the cannulae, if necessary, since they may otherwise be prone to kinking. Avoid shortening the cannula too much so as to prevent an overlap of the connector end and velour, and to ensure that visual inspection of the cannula and connector, respectively, is still possible. Pay attention also to Tab. 9-1, page 120.

### Preparation

#### ► INSTRUCTION

1. Take hold of the cannula extension set (the connecting set resp.).
2. If necessary: cut the section of tube to the desired length. Cut perpendicular to the axis of the tube section and ensure a straight cut. Ensure that the required minimum length is maintained. See Tab. 9-1, page 120. Ensure that the end position of the tube sections, cannulae and blood pump are free of tension.
3. Make sure that the cannulae are free of deposits.

**During implantation/ When replacing a blood pump****➤ INSTRUCTION**

1. Connect the cannula extensions (the connectors resp.) with the blood pump. To do so, push the section of the cannula extension (the connector resp.) onto the titanium connector of the blood pump. Prime the blood pump with the cannula extensions (with connectors resp.).
2. Connect the cannula extensions (the connectors resp.) with the cannulae. To do so, push each cannula onto the titanium connectors of the cannula extension (of the connectors resp.) while flushing with sterile injectable saline solution.
3. Proceed according to context. See section 8.4: Moving the membrane to the end-of-diastole position, page 112 and section 15.1: Replacing the blood pump(s), page 195.

**Without replacing a blood pump****➤ INSTRUCTION**

1. Push the free end of the cannula onto the titanium connector of the cannula extension (of the connector resp.).
2. Flush the tube sections with sterile injectable saline solution.
3. Push the sections of tube, which are free of air, onto the titanium connectors of the blood pump.
4. Proceed according to context. Act according to 15.1.2, page 196 and 15.1.3, page 197 respectively but without replacing the blood pump.

**Securing the connections****➤ INSTRUCTION**

1. Secure each connection between silicone tube and titanium connector with at least 1 cable tie. See section 9.11: Securing the connections, page 130.

**9.4 Access****➤ INSTRUCTION**

1. Median sternotomy. Make sure that there is absolutely no bleeding.
2. Insert standard cardiopulmonary bypass cannulae (bicaval cannulation).
3. Initiate extracorporeal circulation.
4. Place a vent in the left atrium, if necessary.

**9.5 LV apex cannula**

Refer to section 9.2: Use of the cannula tunneling tip, page 117.

### 9.5.1 Anastomosis of inflow cannula with LV apex



During anastomosis of the LV apex cannula, make sure that the cannula head is facing in the right direction: the long side of the head should be parallel to the lateral wall. This prevents the ventricular lateral wall from being sucked into the tip of the cannula. After the cannula head has been placed, its position can be checked by means of the flow direction arrow on the cannula body (except LV apex cannulae C10A-030, C14A-040, C18A-020). The arrow is aligned with the long side of the cannula head (see Fig. 9-7, page 122).

#### INSTRUCTION

1. If indicated, initiate ventricular fibrillation as needed.
2. Apical excision of the LV: The ideal implant position of the LV cannula is slightly off-center of the LV apex toward the lateral wall. The distance from LAD/ septum to the center of the excised muscle core is about 2 cm for children (see 1 in Fig. 9-7, page 122).

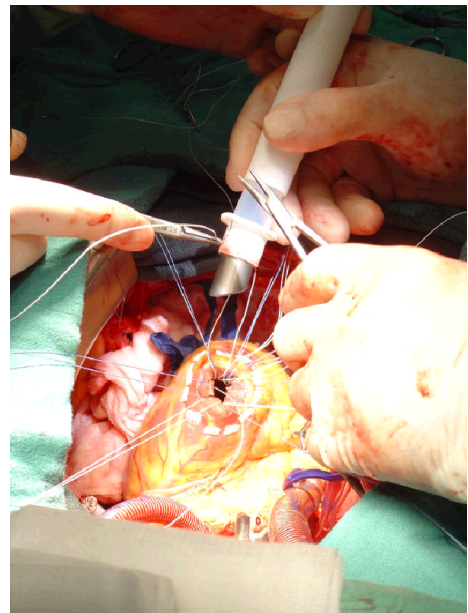

Fig. 9-6 Anastomosis of LV apex cannula

3. We recommend to excise a circular apical core with a diameter slightly smaller than the size of the cannula head.
4. Start with muscle core incision on the side away from the septum/ LAD (see 2 in Fig. 9-7, page 122) to avoid septal injury.
5. Check left ventricle for thrombi and excise the excess trabeculae.

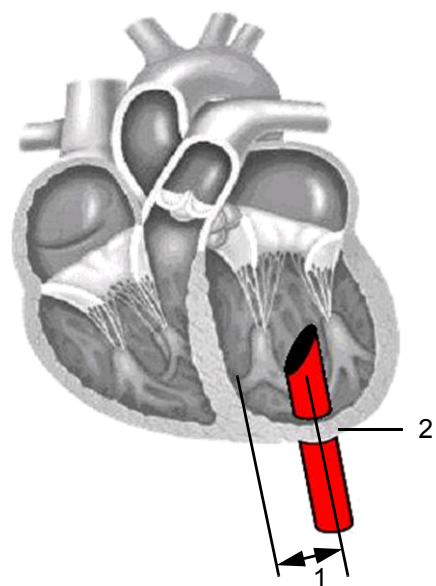

Fig. 9-7 Ideal position of the LV apex cannula

- 1 ca. 2 cm
- 2 see point 4 of instructions



1 Long side of LV apex cannula head

Fig. 9-8 Head of LV apex cannula

## 9.5.2 Creating a transcutaneous tunnel for the LV apex cannula

### **WARNING**

Always use the cannula tunneling tip provided (see section 9.2: Use of the cannula tunneling tip, page 117) to advance the cannula through the prepared transcutaneous tunnel. Never use a sharp surgical instrument directly on the cannula.

Make sure that the blood pump and cannulae come to rest in a stable position without tension.

Do not touch or manipulate the silicone cannulae with pointed or sharp-edged objects (e. g. surgical instruments).

If it is necessary to apply a clamp directly to the cannula in order to pull the cannula through the skin, the following procedures should be observed:

- Position the clamp at the distal end of the cannula
- After the cannula has been pulled through the skin, cut off and discard the part of the cannula where the clamp was applied.
- If it is necessary to clamp any other part of the cannula that is not covered with velour, cover the part of the cannula that will be clamped with a gauze sponge.

The skin incision must be slightly smaller than the cannula diameter (to ensure good ingrowth) but large enough to prevent necrosis.

Plan the cannula exit sites appropriately. Leave an adequate bridge of skin and subcutaneous tissue between the cannula exit incisions to prevent breakdown and necrosis of the skin and tissue. If possible, the cannula exit sites should be on different planes (see Fig. 9-2, page 116).

### **INSTRUCTION**

1. Prepare the transcutaneous tunnel. Ensure that the incision is large enough.
2. Incise the pericardium widely in a lateral direction. Prepare the cannula tunnel by blunt dissection. **IMPORTANT:** Do not tunnel transperitoneally.

3. Tunnel the LV apex cannula through the transcutaneous passage by using a pair of forceps to firmly grip the flat end piece of the tunneling tip and pull it through the cannula tunnel and the skin incision.  
IMPORTANT: Do not rotate the cannula while pulling it through the tunnel. At the end of this procedure, the apex of the heart should be in its native position without torsion.
4. Terminate ventricular fibrillation if necessary.

## 9.6 Atrial cannula(e)

Refer to section 9.2: Use of the cannula tunneling tip, page 117.



### ADVICE

For atrial cannulae supplied with a forming wire, the transcutaneous tunnel should be created and the cannula advanced through the tunnel and skin incision prior to the anastomosis.

For all other atrial cannulae, the sequence is arbitrary.

### 9.6.1 Creating a transcutaneous tunnel for atrial cannula(e)



### WARNING

If possible, always use the cannula tunneling tip provided (see section 9.2: Use of the cannula tunneling tip, page 117) to advance the cannula through the prepared transcutaneous tunnel.

If it is necessary to apply a clamp directly to the cannula in order to pull the cannula through the skin, the following procedures should be observed:

- Position the clamp at the distal end of the cannula
- After the cannula has been pulled through the skin, cut off and discard the part of the cannula where the clamp was applied.
- If it is necessary to clamp any other part of the cannula that is not covered with velour, cover the part of the cannula that will be clamped with a gauze sponge.

Care must be taken to ensure that the cannulae come to rest in a stable position free of tension.

Do not touch or manipulate the silicone cannulae with pointed or sharp-edged objects (e. g. surgical instruments).

Using a pair of forceps, firmly grip the flat end piece of the tunneling tip and pull it through the cannula tunnel and the skin incision.

IMPORTANT: Do not rotate the cannula while pulling it through the tunnel.

The incision must be slightly smaller than the cannula diameter (to ensure good ingrowth) but large enough to prevent necrosis.

Plan the cannula exit sites appropriately. Leave an adequate bridge of skin and subcutaneous tissue between the cannula exit incisions to prevent breakdown and necrosis of the skin and tissue. If possible the cannula exit incisions should be on different planes.

#### ➤ INSTRUCTION

1. Prepare the transcutaneous tunnel. Ensure that the incision is large enough.
2. Prepare the cannula tunnel by blunt dissection. **IMPORTANT:** Do not tunnel transperitoneally.
3. Using a pair of dressing forceps, tunnel the cannula through the transcutaneous tunnel. **IMPORTANT:** Do not rotate the cannula while pulling it through the tunnel.

### 9.6.2 Anastomosis of atrial cannulae

#### Right atrium

##### ADVICE

Create the anastomosis laterally, directly above the tricuspid valve.

#### a) closed technique

##### ➤ INSTRUCTION

1. Make a running (purse-string) suture with monofilament, secured with pledgets at 4 positions.
2. Place 4 single U-sutures secured with pledgets on each side of the purse string suture.
3. Make a sufficiently long incision inside of the suture circle and extend it as required.
4. Push the cannula down on the sutures, at the same time slightly reduce the venous inflow to the CPB while inflating the lung in order to prevent negative pressure in the left atrium.
5. Remove all air from the cannula and use a tube clamp to clamp the cannula below the anastomosis.

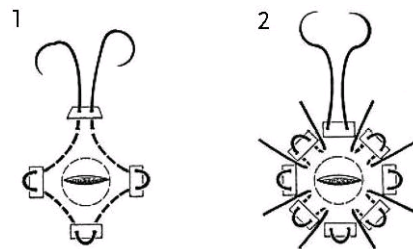

Fig. 9-9 Suture technique, right atrium

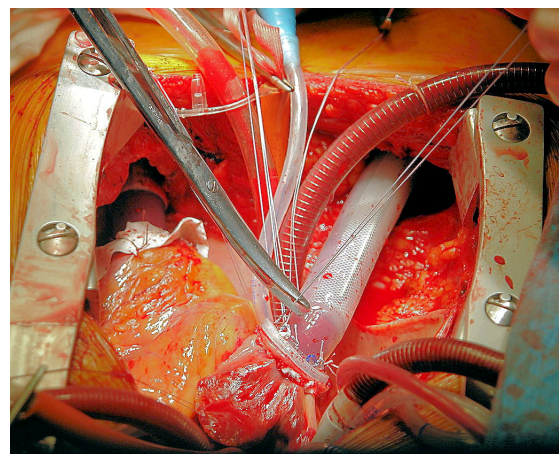

Fig. 9-10 Cannulation of right atrium

#### b) open technique with bicaval cannulation

With bicaval cannulation, the right atrial cannula can be inserted in an open technique.

### Left atrium

The procedure for anastomosis of the left atrium corresponds to the procedure applied to the right atrium.

 **ADVICE**

Place anastomosis at the junction of the right upper pulmonary vein and the left atrium. The atrial wall is the recommended implantation location. The pulmonary vein should be left intact.

## 9.7 Arterial cannula(e)

Refer to section 9.2: Use of the cannula tunneling tip, page 117.

 **ADVICE**

For cannulae supplied with a forming wire, the transcutaneous tunnel should be created and the cannula advanced through the tunnel and skin incision prior to the anastomosis.

### 9.7.1 Creating a transcutaneous tunnel for arterial cannula

 **WARNING**

Care must be taken to ensure that the blood pump and cannulae come to rest in a stable position.

Do not touch or manipulate the silicone cannulae with pointed or sharp-edged objects (e. g. surgical instruments).

Using a pair of forceps, firmly grip the flat end piece of the tunneling tip and pull it through the cannula tunnel and the skin incision. **IMPORTANT:** Do not rotate the cannula while pulling it through the tunnel.

The incision must be smaller than the cannula diameter (to ensure good ingrowth) but large enough to prevent skin necrosis.

Plan the cannula exit sites appropriately. Leave an adequate bridge of skin and subcutaneous tissue between the cannula exit incisions to prevent breakdown and necrosis of the skin and tissue. If possible the cannula exit incisions should be on different planes (see Fig. 9-2, page 116).

 **INSTRUCTION**

1. Prepare the transcutaneous tunnel. Ensure that the incision is large enough.
2. Prepare cannula tunnel by blunt dissection. **IMPORTANT:** Do not tunnel transperitoneally.
3. Using a pair of forceps, firmly grip the flat end piece of the tunneling tip and pull it through the cannula tunnel and the skin incision. **IMPORTANT:** Do not rotate the cannula while pulling it through the tunnel.



## 9.7.2 Anastomosis of the arterial cannula

### Aorta

#### ➤ INSTRUCTION

1. Tangentially clamp the ascending aorta and make a longitudinal opening of a length which is suitable for the cannula diameter. If necessary, offset the incision laterally to the right by up to 45°.
2. Anastomose the cannula using ten teflon-backed double-reinforced individual monofilament (e. g. 4-0 EB) U-sutures. (If simpler conditions are encountered, a running suture can be made instead.)
3. Remove all air from the cannula and use a tube clamp to clamp the cannula below the anastomotic site. If it is necessary to clamp any other part of the cannula that is not covered with velour, cover the part of the cannula that will be clamped with a gauze sponge.

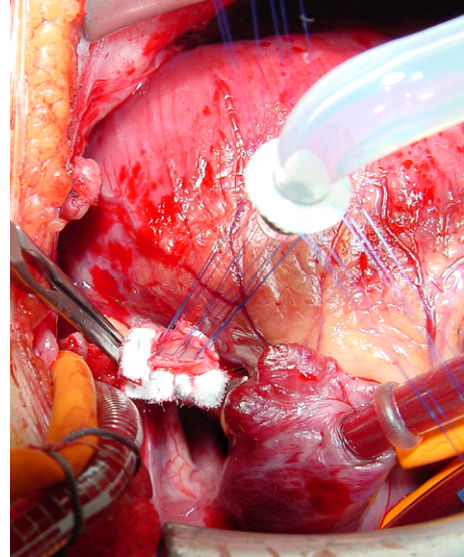

Fig. 9-11 Anastomosis of the aortic cannula

### Pulmonary artery

#### ➤ INSTRUCTION

1. Make a longitudinal incision of a size suitable for the cannula diameter in the pulmonary artery.
2. Anastomose the cannula using 10 teflon-backed, double-reinforced individual monofilament (e. g. 4-0 EB) U-sutures. (If simpler conditions are encountered, a running suture can be made instead.)
3. Remove all air from the cannula and use a tube clamp to close it below the anastomosis. If it is necessary to clamp any other part of the cannula that is not covered with velour, cover the part of the cannula that will be clamped with a gauze sponge.

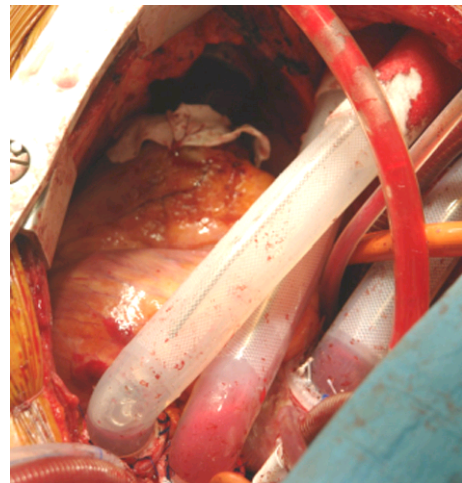

Fig. 9-12 Cannulation of the pulmonary artery

## 9.8 Shortening the cannulae if necessary



**WARNING**

If an EXCOR cannula extension set / connecting set is required for implantation and the length of the tube part needs to be reduced, the tube part should be cut but only to achieve the following minimum lengths:

Article	Diameter / Diameter reduction	Minimum length
<b>Cannula extension set</b>		
A06-006	6 mm	55 mm
A09-009	9 mm	60 mm
A12-012	12 mm	75 mm
<b>Connecting set</b>		
A06-009	9 to 6 mm	60 mm
A09-012	12 to 9 mm	75 mm

**Tab. 9-2** Cannula extension set / connecting set: minimum length of tube section

### ➤ INSTRUCTION

1. Cut the cannulae to the required length. Make the cut perpendicular to the cannula axis and ensure that the cut is straight.
2. Make sure that the lengths of the 2 cannulae leading to the same pump match. It must be possible to connect the cannulae to the pump without having to exert any tension.

## 9.9 Connecting the blood pumps to the cannulae



**WARNING**

Ensure that cannulae, blood pump(s) and driving tubes are not subject to external forces and are free of kinks or sharp bends.

When connecting the blood pump(s), pay attention to the direction of the arrows on the inflow and outflow stubs. These show the direction of the blood flow.

Type of support	Anastomosis of inflow cannula to	Points upwards...
<b>Univentricular</b>		
LVAD	apex	blood chamber
LVAD	atrium	air chamber

**Tab. 9-3** Anastomosis and direction of the blood chambers

Type of support	Anastomosis of inflow cannula to	Points upwards...
<b>Biventricular</b>		
LVAD	apex	blood chamber
LVAD	atrium	air chamber
RVAD	atrium	air chamber

**Tab. 9-3** Anastomosis and direction of the blood chambers

**NOTICE**

Finally, the driving tube is connected to the Ikus. The Ikus is started and the parameters are gradually adjusted (see section 7.2.10: Checking the parameters when the pump is started and adjusting them, page 103).

**INSTRUCTION**

1. Bring the patient into the Trendelenburg position.
2. Release the tube clamps, flush the cannulae and then use tube clamps to clamp the cannulae below the exit sites. If it is necessary to clamp any other part of the cannula that is not covered with velour, cover the part of the cannula that will be clamped with a gauze sponge.
3. First connect the inflow cannula to the pump, then connect the outflow cannula. When doing so, add sterile injectable saline with a bulb syringe in order to connect the pump air free. Be careful to avoid damaging the gloves and the inner cannula (lumen) and pump surfaces.
4. Release the tube clamps, de-air the pump(s) and the cannulae.
5. Connect the driving tube to the blood pump. Biventricular: use the red driving tube for the left blood pump and the blue driving tube for the right blood pump. Univentricular: always use the red driving tube.

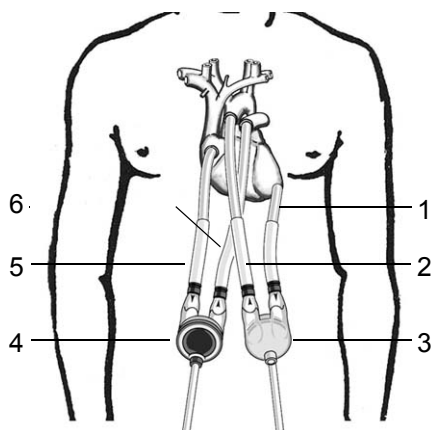

- 1 inflow cannula from LV apex
- 2 outflow cannula to ascending aorta
- 3 left pump (blood-chamber pointing upwards)
- 4 right pump (air-chamber pointing upwards)
- 5 inflow cannula from right atrium
- 6 outflow cannula to pulmonary artery

**Fig. 9-13** Final position of the blood pumps, for example: BVAD with LV apex cannulation

## 9.10 Removing the de-airing needle

**WARNING**

When removing the de-airing needle, never pull on the de-airing tube, but on the de-airing needle itself.

Before removing the de-airing needle, be sure that the de-airing tube is secured to the de-airing needle. **IMPORTANT:** Once the de-airing needle has been removed it cannot be re-inserted.

**NOTICE**

Do not remove the de-airing needle until all air is removed, the blood pump is running, all parameters have been adjusted and the chest has been closed. (see section 7.2.10: Checking the parameters when the pump is started and adjusting them, page 103).

**INSTRUCTION**

1. Cut the suture material between the de-airing needle and the de-airing nipple (see image 1 in Fig. 9-14, page 130). **IMPORTANT:** Leave the ligature around the de-airing nipple (see image 2 in Fig. 9-14, page 130).
2. Pull the de-airing needle out of the de-airing nipple.

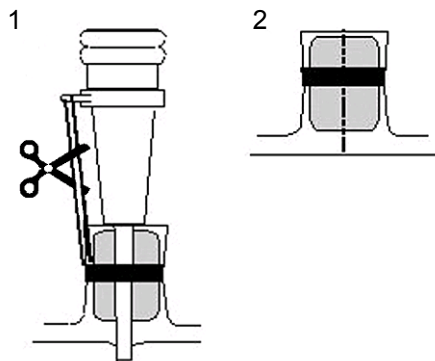

Fig. 9-14 Removing the de-airing needle

After the patient has been weaned from the CPB and the proper function of the EXCOR is established, the connections of the driving tubes and cannulae to the blood pump(s) have to be secured.

## 9.11 Securing the connections

**WARNING**

All connections have to be secured by at least 1 cable tie. 2 cable ties may be used. Exception: connection between drive line and drive line connector of the blood pump: 1 cable tie only!

**INSTRUCTION**

1. Pick up the Tube connecting set.
2. Secure the following connections:
  - inflow cannula on the connector of pump / cannula extension set / connecting set
  - outflow cannula on the connector of pump / cannula extension set / connecting set
  - cannula extension set / connecting set on the connector of the pump
  - drive line on the drive line connector (1 cable tie only!)

3. The 1<sup>st</sup> cable tie must be positioned exactly on the groove profile of the connector (1).  
**IMPORTANT:** the heads of the cable ties have to be directed away from the patient's body.
4. Fasten the cable ties by the cable tie gun. **IMPORTANT:** pay attention to section 8.2: Checking and adjusting the settings of the cable tie gun, page 109.
5. A 2<sup>nd</sup> cable tie can be used optionally. If a 2<sup>nd</sup> cable tie shall be used (2) it has to be positioned above the 1<sup>st</sup> cable tie. **IMPORTANT:** the heads of the cable tie straps should both be staggered and directed away from the patient's body.

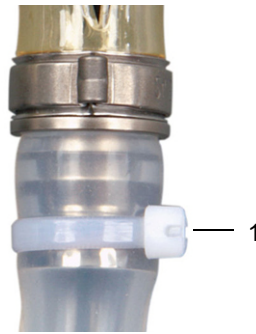

**Fig. 9-15** Cable tie, exactly positioned

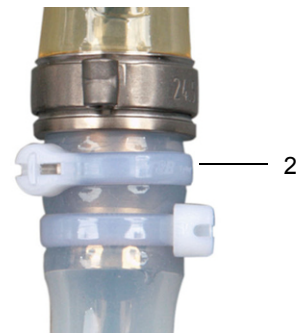

**Fig. 9-16** 2nd cable tie (optional)

6. If an EXCOR cannula extension set / connecting set is required for implantation after that secure also those connections with cable ties. Proceed thereby as described in the instruction steps 3 to 5.

*This page was left blank intentionally*

## 10 Implantation - anesthesia

The following risk factors should be closely monitored for anesthetic and hemodynamic management:

- right heart function during LVAD implantation
- coagulopathy
- renal insufficiency
- abnormal reactions to inotrope administration
- pulmonary hypertension

### CAUTION

---

There should be an adequate supply of pre-matched stored blood, fresh frozen plasma and platelet concentrates available for immediate transfusion if required.

---



---

Keep blood product transfusions to a minimum. Blood transfusions may lead to the development of antibodies, which are known to promote coagulation and inflammatory response.

---

### ADVICE

---

Medication for right ventricular afterload reduction should be available for use in the operating room (nitric oxide NO, phosphodiesterase inhibitor, prostaglandin, etc)

---



---

Auto-transfusion equipment (e. g. Cell saver) should be available for use in the operating room.

---



---

For patients with an LVAD, start ventilation with nitric oxide or administer the appropriate medication to treat pulmonary hypertension and reduce afterload for right ventricle 15 minutes before weaning from the CPB. This can help to prevent or lower the risk of right ventricular failure.

---

### Monitoring procedure

Intraoperative monitoring should include the same monitoring procedures applied during major cardiothoracic surgery:

- central venous line
- Swan-Ganz catheter (if appropriate)
- arterial line
- ECG
- pulse oximetry
- central temperature monitor
- urine catheter

### Additional recommended monitoring procedures

- cardiac output calculation (if appropriate)
- intraoperative transesophageal echocardiogram (inflow cannula position, heart valve function, intracardial shunts, volume status)
- right heart function in case of LVAD

Any other monitoring processes can be used (e. g. neurological monitoring) at the anesthesiologist's discretion.



# 11 Wound care and treatment

Cannula exit sites should be treated like open wounds. The patient's wounds should always be attended to by a small group of nurses in the inpatient area.

The only way to ensure there is a minimum risk of infection is to provide good wound care.

**WARNING**

---

Before cleaning the wound (see section 11.3: Cleaning of the wound, page 137), put on sterile disposable gloves, cap and mask.

---

Cleaning the pump and the drive line: Do not use any acetone or petroleum based products near the pump or drivelines. We recommend using only water or alcohol to clean the pump and the drive line.

**IMPORTANT:** Do not use any corrosive or colored solutions or organic solvents to clean the blood pump or the drive line as they may alter the surface of the product.

---

Cleaning the cannulae and transcutaneous exit site: Do not use any acetone or petroleum based products near the cannulae and the transcutaneous exit site.

We recommend using chlorhexidine to clean the cannulae and transcutaneous exit site.

**IMPORTANT:** Do not use any corrosive or colored solutions or organic solvents to clean the cannulae and the transcutaneous exit site as they may alter the surface of the product.

---

**NOTICE**

---

Do not stick bandages to the cannulae. Over time, remnants of adhesive contaminate the cannulae and increase the risk of infection.

---

Do not use any adhesive on the velour coating of the cannula as it is difficult to remove and may adversely manipulate the cannula.

---

Do not use organic solvents near the EXCOR Pediatric such as petroleum ether or turpentine oil, as they could damage the cannulae and the pumps. The plastic parts must not get in contact with chlorinated hydrocarbon (e.g. chloroform), thinners (e.g. acetone, naphtha, toluol, xylene, heptane) or similar compounds.

---

Do not mark or write on the plastic parts.

---



**Material required (with biventricular access):**

- Sterile dressing tray
- Disinfectant i.e. 2% chlorhexidine solution
- Clean gloves
- Mask
- Sterile gloves and towel
- *Metalline*<sup>®</sup> drain compress
- 2X2 gauze, 4X4 gauze
- Adhesive dressing (i.e. *Mepore*<sup>®</sup>)
- Adhesive remover
- Non sting barrier film sticks
- Abdominal pads
- Tape
- Tubular bandage (i.e. *Burnnet*)

**Fig. 11-1** Materials for dressing change

**How often to change the dressing**

If the wound is dry and not infected:

- POD 1- once a day
- POD 11-28 every second day, if the wound is dry and not infected
- POD>28 twice a week, if the wound is dry and not infected

If the wound shows signs of infection: clean wound and change dressing twice a day

## 11.1 Removing the old dressings

**➤ INSTRUCTION**

1. Unpack all the material required to dress the wound and place this within reach on a sterile sheet.
2. Put on disposable gloves, remove old dressings.
3. Take off the disposable gloves, put on the sterile gloves.
4. Remove old dressing using no-touch technique.
5. Examine the places where the cannulae pass through the skin and if changes are apparent take appropriate measures if necessary.
6. Use adhesive remover to remove any adhesive dressing.  
IMPORTANT: adhesive remover (depending on contents) might damage cannula and the pump, use only on skin.

## 11.2 Cleaning the blood pump

### ► INSTRUCTION

1. Cleanse the exposed cannula and the pump head with disinfectant (i.e. 2% chlorhexidine solution) then place on sterile towel.
2. Examine cannulae and cannulae exit sites.
3. Remove gloves.



Fig. 11-2 Cleaning the blood pump



Fig. 11-3 Examining the cannulae

## 11.3 Cleaning of the wound

### ► INSTRUCTION

1. Hand hygiene, prepare sterile dressing tray, put on sterile gloves. If assistance is necessary notify Berlin Heart.
2. 4X4 gauze soaked in 2% chlorhexidine cleanse each cannula exit site in a circular motion outward to a radius of approximately 10 cm.
3. Using a new soaked 4X4 repeat 2 more times beginning at the exit site and clean in larger circles each time.
4. Wrap 4X4 gauze soaked in 2% chlorhexidine around cannula and gently cleanse with back/forth motion.
5. Repeat with each cannula exit site.

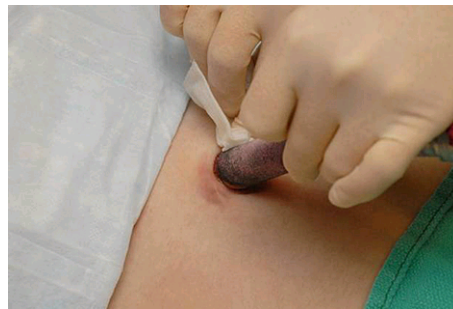

Fig. 11-4 Cleanse each cannula exit site



Fig. 11-5 Cleanse with back/forth motion

6. Cleanse entire cannula (upper and bottom side).
7. 4X4 gauze soaked in 2% chlorhexidine solution.
8. Starting at the exit site moving down cannula approximately 10 cm from exit site.
9. Repeat for each cannula exit site.
10. Allow chlorhexidine to dry completely.



Fig. 11-6 Cleanse entire cannula

## 11.4 The new dressing

### 11.4.1 Preparing a new dressing

#### ➤ INSTRUCTION

1. Apply non sting barrier film to skin around cannulae. Non sting barrier prevents skin maceration around cannula exit sites.



Fig. 11-7 Non sting barrier film

### 11.4.2 Applying a new dressing

#### ➤ INSTRUCTION

1. Wrap a *Metalline* drain compress around each cannula (from right to left, slit always facing upwards).



Fig. 11-8 Metalline drain compress

2. Attach the *Metalline* drain compresses above the cannulae using sterile bandages. First secure the outer compresses, then the inner compresses.

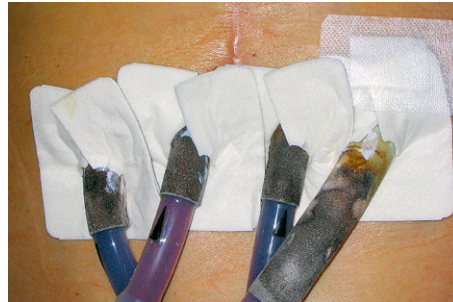

**Fig. 11-9** Secure with a sterile bandage

3. Pass a gauze compress folded lengthwise beneath the 2 left cannulae. The open end of the folded compress should point in the direction of the wound. Pull the cannulae into place by tugging the compress slightly.



**Fig. 11-10** Gauze compress under the cannulae

4. Fold the left end of the compress upwards, diagonally to the right and secure with a sterile bandage .

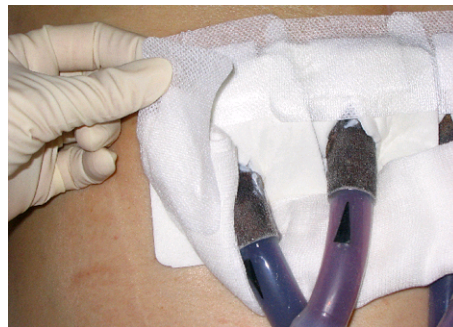

**Fig. 11-11** Fold the left end of compress and secure

5. Fold the right end of the compress upwards, diagonally to the left and secure with a sterile bandage.



**Fig. 11-12** Fold the right end of compress and secure

6. Repeat this procedure for the 2 right cannulae. In this way, the 4 cannulae are padded so that they do not press on the skin or wound.

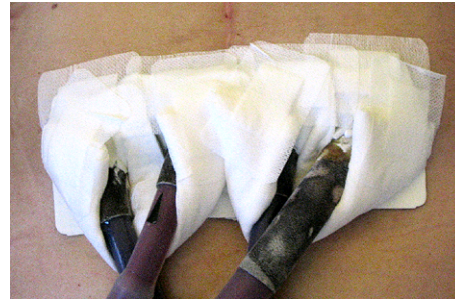

Fig. 11-13 Cannulae are padded

7. Cover the entire wound broadly with gauze compresses.



Fig. 11-14 Cover with sterile gauze compresses

8. Secure the upper part of the dressing with a sterile bandage.



Fig. 11-15 Secure with a sterile bandage

9. Finally, seal the dressing at the left and right side, below the cannulae and between the individual cannulae with strips of adhesive bandage (e. g. Leukoplast).



Fig. 11-16 Seal with strips of adhesive bandage

10. Place tubular bandage (i.e. *Burnnet*) around patient.

11. Tie in front to secure dressing.



Fig. 11-17 Tubular bandage

## 11.5 Regular checks of blood pump(s) and cannulae

**Frequency of inspection: every 4 hours**



---

Everyone involved in caring for an EXCOR patient must be trained to carry out a visual check, to evaluate the filling behavior of the blood pump(s) and to detect deposits.

---



---

At least daily, the EXCOR cannulae should be inspected for signs of wear or damage. **ADVICE:** To avoid needless kinking of the cannulae use a mirror for inspection of the bottom side of the blood pump.

---



---

Educate the patient, family and caregiver to avoid pulling, kinking or any activity that could put stress on the cannula. Remind them periodically of the importance of protecting the cannula and blood pump. Do not allow patient to belly flop, pull or stretch the cannula, as this may damage the cannula resulting in injury or death to the patient.

---



---

At least every 4 hours, check visually that the blood pump(s) is (are) filling and ejecting completely over a period of several pump cycles. If a pump is not filling and/ or ejecting completely, then take the appropriate corrective action.

---

### 11.5.1 Visual inspection: pump filling and ejection

The filling and ejection behavior of a blood pump is optimal when the membrane surface is completely smooth at the end-of-systole and end-of-diastole positions. Check visually that the pump(s) is (are) filling and ejecting completely over a period of several pump cycles. If a pump is not filling and/ or ejecting completely, take the appropriate corrective action.

#### Cautionary measures

For all blood pumps: check the position and condition of the driving tube and the cannulae (inflow deterioration due to kinks in cannulae/driving tubes is rather rare).

For all blood pumps: check the membrane movement.

#### Medical examination of patient

Check CVP, mean arterial pressure and adjust therapy if necessary.

#### Check the volume status:

- amount of bleeding
- increased urine output (use of diuretics?)
- tamponade
- **IMPORTANT:** Increasing the suction pressure will not bring about any distinct improvement if there is not sufficient volume available.

LVAD: observe the functions of the right ventricle.

### Adjusting the parameter values

Only adjust the parameters if the measures listed above have no effect or in case of:

- Mobilization of patient: adjust the systolic pressure, both left and right. When pressures have increased, do not reduce these again, even when the patient is lying down.
- Signs of low cardiac output: the membrane is moving properly while at the same time a decrease in urine output, lactate increase and dyspnea (shortage of breath) can be observed. In this case, increase the rate and adjust other settings as required.

#### INSTRUCTION

1. Use the <←>/<→> keys to move the cursor to the desired field in the parameter table. The selected field is given a colored background.
2. Use the <↓>, <↑> and <Bild-↓>, <Bild-↑> keys to adjust the value, then press <Enter> to confirm the input. The system will now operate using the new settings.

### Cautionary measure

Confirm each changed parameter value by pressing <Enter>. The system does not take over the new, changed value until it has been confirmed with <Enter>.

#### ADVICE

---

Enter all the changes to the parameter values into the parameter log. (see section 16.7: Pump performance flow sheet, page 230).

---

## 11.5.2 Visual inspection: deposits

Check the blood pump(s) and the visible part of the cannulae (cannula extension set / connecting set resp.) for visible deposits (fibrin, clots) every 4 hours. If deposits develop, check the pump(s) every hour.



**Checking the pump areas which come in contact with blood**

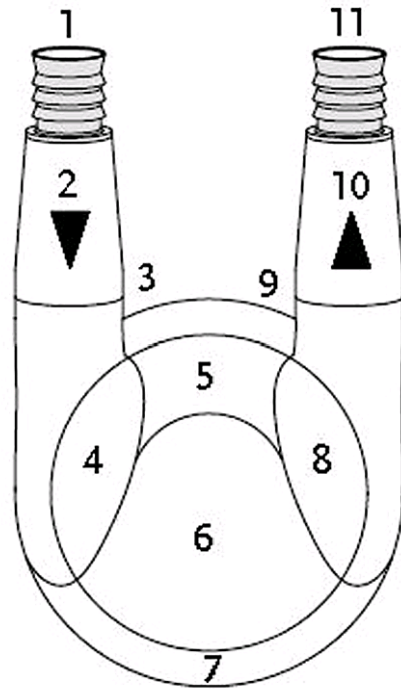

- 1 transition inflow cannula – inflow connector
- 2 inflow stub in front of inflow valve
- 3 inflow valve
- 4 inflow stub behind inflow valve
- 5 area between inflow and outflow stubs
- 6 remaining area of blood chamber
- 7 transition blood chamber - membrane (directly above the reinforcement ring)
- 8 outflow stub in front of outflow valve
- 9 transition outflow connector – outflow cannula
- 10 outflow valve
- 11 outflow stub behind outflow valve

**Fig. 11-18**Diagram of EXCOR blood pump (top view of blood chamber)

**ADVICE**

During the visual check, first clean the blood pump then illuminate the blood chamber with a flashlight. This makes it easier to detect deposits. Enter all of the findings into the blood pump log. (see section 16.6: Sample copy: EXCOR pump log, page 227).

**Cautionary measures**

Initial signs of deposits: check anticoagulation therapy and adjust therapy if necessary.

Floating deposits inside the pump: replace the pump!

**11.5.3 Checks using the monitor program**

Record all drive parameters and adjust if necessary.

Objective: the blood pump(s) must fill and eject completely in each pumping cycle, the diastolic pressure should be as low as possible.

**ADVICE**

Record the parameter values once a day.

To record the parameters use the sample copy in section 16.7: Pump performance flow sheet, page 230.

### 11.5.4 Replacing the blood pump due to growth of the patient



In children, plan to replace the pump(s) with a larger pump(s) in good time, to prevent the possibility of inadequate support due to an insufficient discharge rate.

---

The pump selected at the time of transplantation may not be adequate for the entire period of cardiac support. Growth and/or weight gain can result in the patient not receiving adequate support. Use the chart in section 16.1.2: Overview: Relationship: body weight – pump size, page 211, to plan, in good time, which pump(s) the patient may need to change over to. This chart is for guideline purposes only and is not binding for each individual case. This decision must be taken by the surgeon in consultation with Berlin Heart GmbH.



**Notify Berlin Heart! 866.249.0128**

---

The blood pump(s) must be replaced as described in section 15.1: Replacing the blood pump(s), page 195.

## 12 Anticoagulation therapy

### 12.1 Before Implantation of the EXCOR

#### 12.1.1 General considerations

Patients with an EXCOR system must be maintained on anticoagulation therapy.

Anti-Xa levels should be specific to the drug being used, either unfractionated heparin or enoxaparin.

The TEG® may be useful in managing unfractionated heparin and antiplatelet therapy. Please contact Berlin Heart, Clinical Affairs for further information.

#### 12.1.2 Pre implantation

The following laboratory tests should be considered prior to implantation.

- Platelet Function Studies, INR, PTT, fibrinogen, antithrombin III, and platelet count to establish a baseline. Assessment for thrombophilia by measuring Protein C, S, Factor V Leiden, Prothrombin 20210 defect, as well as Heparin Induced Thrombocytopenia (HIT) is recommended.

### 12.2 During Implantation - Cardiopulmonary Bypass

#### 12.2.1 Cardiopulmonary Bypass (CPB)

Use unfractionated heparin as per institutional protocol for cardiopulmonary bypass.

#### 12.2.2 Post CPB

Completely reverse heparin with protamine sulphate as per institutional protocol.

The goal post-CPB is to achieve normal (institution specific) coagulation parameters (INR, PTT, fibrinogen, platelet count).

In the early post-operative period, the possibility of surgical bleeding, GI bleeding, internal bleeding in the retro-peritoneum or other bleeding diathesis is possible and must be monitored.

If the patient is bleeding despite normal coagulation parameters consider:

- Von Willebrand's
- Surgical bleeding

### 12.3 Postoperative anticoagulation therapy

#### 12.3.1 General Considerations

Primary tests used to evaluate anticoagulation in the patient include antifactor Xa levels and/or PTT.

#### 12.3.2 Starting anticoagulation therapy

During the first 24 hours following implantation, no anticoagulants should be administered.

Approximately 24 - 48 hours after implantation, commence unfractionated heparin therapy (i.v.) if the following criteria are met:

- Platelet count >20,000/ $\mu$ l
- Normal Platelet Function Studies
- Minimal bleeding in infants and young children.

### **12.3.3 Unfractionated heparin therapy (i.v.) Patient < 12 months**

- Initial dose 15 IU/kg/hour.
- Do not use a bolus
- After 6 hours if the patient does not have increased bleeding, increase the heparin infusion to 28 IU/kg/hour (therapeutic dose).

6 hours after increasing the heparin to the therapeutic dose, obtain a PTT and an antifactor Xa level.

If the anti factor Xa level is desired range (0.35-0.5 U/ml) and the PTT is in the therapeutic range (institution dependent), then either the PTT or anti factor Xa level may be used to follow the heparin therapy.

If the anti factor Xa level is <0.35 U/ml or >0.5 U/ml, increase or decrease the heparin infusion, respectively until the anti factor Xa level is the therapeutic range (see Tab. 12-1, page 150).

Anti factor Xa levels should be obtained daily. IMPORTANT: hyperbilirubinemia may result in falsely low anti factor Xa levels. If anti Xa levels do not correlate with the PTT in this setting, consider using the PTT to monitor heparin therapy.

Antithrombin should be >70%. If the antithrombin is <70%, treat according to institutional protocol.

### **12.3.4 Unfractionated heparin therapy (i.v.) Patient $\geq$ 12 months**

Initial dose 10 IU/kg/hour.

Do not use a bolus.

After 6 hours if the patient does not have increased bleeding, increase the heparin infusion to 20 IU/kg/hour (therapeutic dose).

6 hours after increasing the heparin to the therapeutic dose, obtain a PTT and an anti factor Xa level.

If the anti factor Xa level is desired range (0.35-0.5 U/ml) and the PTT is in the therapeutic range (institution dependent), then either the PTT or anti factor Xa level may be used to follow the heparin therapy.

If the anti factor Xa level is < 0.35 U/ml or > 0.5 U/ml, increase or decrease the heparin infusion, respectively until the anti factor Xa level is the therapeutic range (see Tab. 12-1, page 150).

Anti factor Xa levels should be obtained daily. IMPORTANT: hyperbilirubinemia may result in falsely low anti factor Xa levels. If anti Xa levels do not correlate with PTT in this setting, consider using the PTT to monitor heparin therapy.

Antithrombin should be >70%. If the antithrombin is <70%, treat according to institutional protocol.

**NOTICE**

---

If during standard unfractionated heparin therapy:

1. Platelet count is < 40,000/ $\mu$ l revert to the Stage I heparin dose for continuous infusion (see Tab. 12-1, page 150)
  2. Platelets <20,000/ $\mu$ l discontinue heparin and consider evaluation for heparin induced thrombocytopenia (HIT).
- 

---

If the anti factor Xa or PTT is too low or too high during heparin therapy, never use a bolus of heparin or protamine. Instead, increase or decrease the heparin dose, IU/hour, as required (see Tab. 12-1, page 150).

---

### 12.3.5 Thrombelastography (TEG<sup>®</sup>)

TEG<sup>®</sup> analysis may be useful in managing the anticoagulation and anti-platelet therapy. Please contact Berlin Heart Inc., Clinical Affairs for further information.

## 12.4 Low Molecular Weight Heparin

At 48 hours following surgery if all bleeding has stopped, the creatinine is within normal limits, and the patient is hemodynamically stable, switching from unfractionated heparin to low molecular weight heparin (LMWH) is recommended.

- Patient < 3 months start administration of Enoxaparin at 1.8 mg/kg subcutaneously every 12 hours.
- Patient > 3 - 12 months start administration of Enoxaparin at 1.4 mg/kg subcutaneously every 12 hours.
- Patient > 1 – 5 years start administration of Enoxaparin at 1.2 mg/kg subcutaneously every 12 hours.
- Patient > 5 – 16 years start administration of Enoxaparin at 1.1 mg/kg subcutaneously every 12 hours.
- Stop heparin infusion and administer LMWH (subcutaneously) simultaneously.
- Obtain the first anti factor Xa level at 4 hours after the 2nd LMWH dose is administered. See Tab. 12-2, page 150 for monitoring and dosing.
- Anti factor Xa therapeutic range: 0.6 to 1.0 U/ml.
- Anti factor Xa should be monitored along with platelet count, and creatinine
- When using LMWH, monitor Anti factor Xa daily. Once the Anti Factor Xa level is in the therapeutic range at a stable dose, monitor twice a week for 2 weeks, and then weekly.

## 12.5 Oral Anticoagulation Therapy (only for patients $\geq$ 12 months of age who are taking a full oral diet)

**ADVICE**

---

This section only applies to patients  $\geq$  12 months. Oral anticoagulation in children < 12 months of age is not recommended due to difficulties with monitoring the warfarin effect.

---

When the patient's condition has been fully stabilized (e.g. hemodynamically stable, no evidence of bleeding, etc), switch to oral anti-coagulation therapy with a vitamin K antagonist (target INR: 2.7 to 3.5), with an initial loading dose of 0.2 mg/kg/day. Do not exceed maximum loading dose of 5mg/day. The INR must be checked daily in the first

4 weeks, twice a week for the next 4 weeks (if INR is stable), and once a week thereafter (see Tab. 12-3, page 151 and Tab. 12-4, page 151).

Until the target INR is achieved, simultaneous administration of warfarin and heparin is necessary (approximately 4 days). Once the target INR is achieved, heparin therapy can be discontinued. If the INR decreases to < 2.7, administer LMW heparin immediately and then q12h until an INR of > 2.7 is achieved (see Tab. 12-5, page 151). If INR is 2.0- 2.7 use an enoxaparin dose of 0.5 mg/kg targeting an anti factor Xa level of 0.3-0.5, if INR is <2.0 use an enoxaparin dose of 1 mg/kg targeting an anti factor Xa level of 0.5 - 1.0.

When unable to achieve a stable INR with warfarin, LMWH should be used instead. Discontinue the warfarin and administer LMWH as per previously discussed age related dosing (see Tab. 12-2, page 150).

## 12.6 Monitoring of Blood Count and Anticoagulation Status

Monitoring the anticoagulation status as well as infection risk, and renal and hepatic function is important and should be monitored with the following frequency:

- Daily while on UFH, twice a week while on enoxaparin/coumadin for 4 weeks then once a week: Fibrinogen, D-dimer, aPTT, PT/INR, Platelet Count, TEG<sup>®</sup>, Antithrombin, WBC, HgB, HCT, BUN/SCr, AST/ALT, bilirubin T/D, prealbumin, CRP.
- While on UFH obtain anti factor Xa level daily.
- While on enoxaparin obtain anti factor Xa daily until in therapeutic range and on a stable dose, then twice a week for two weeks and then weekly.

If infection is suspected, appropriate measures must be taken immediately (antibiotic therapy, adjustment of the anticoagulation and platelet inhibition therapy) and increased monitoring of the coagulation system. In addition, in the setting of hemodynamic instability, organ dysfunction, and inadequate anticoagulation daily monitoring should be performed until any of these issues are resolved.

## 12.7 Postoperative platelet inhibition therapy

As individual patient responses vary to the anti-platelet agents, the optimum dosage for each patient will be that which minimizes both the risk of thromboembolic complications when the dose is too low and the risk of hemorrhagic complications when the dose is too high. Acetylsalicylic acid (ASA) and dipyridamole are the anti-platelet agents recommended.

### 12.7.1 Start of therapy

#### Dipyridamole

At 48 hours after surgery, start dipyridamole, 4mg/kg/day p.o. divided into 4 doses (1 mg/kg Q6) (maximum dose 15mg/kg/day). If the following are present:

- All bleeding has stopped, AND
- The patient is hemodynamically stable AND,
- Platelet studies do not show significantly decreased function,
- Platelet count is > 40,000/ $\mu$ l

**Acetylsalicylic Acid**

At 4 days post implantation, following the removal of all drainage tubes, start acetylsalicylic acid (ASA) 1mg/kg/day p.o., divided into 2 doses (0.5 mg/kg Q 12), if the following are present:

- Platelet studies show platelet inhibition in the presence of AA < 70 %

The ASA dose should split and be administered two times daily (0.5 mg/kg Q 12) due to the short half life and the high turnover of the platelets (approximately 10 % new platelets per day).

**12.8 Adjunctive Medication**

The inflammation parameters (Tissue factor pathway inhibitor, prothrombin fragment 1-2, fibrinogen, Factor VIII) for patients on ventricular assist device support are often elevated above normal. Accordingly, the physician may choose to administer the following medications at his/her discretion to facilitate the overall anticoagulation/anti-platelet management of the patient:

- Omega-3 fatty acids (e.g. DHA/EPA), have been shown to have an anti-inflammatory effect and also decrease premature activation of platelet membrane. Omega-3-fatty acids are composed of long chain polyunsaturated long chain carbons. Only alpha-linolenic acid (ALA) of the omega-3 family is truly essential.

Antioxidants (Vitamin C and E) also have been shown to have an anti-inflammatory effect, and may be considered.

**12.9 Anticoagulation Therapy****12.9.1 Therapeutic Heparin administration and adjustment****NOTICE**

---

This table assumes the site therapeutic PTT is 60 to 85 seconds (Monagle, P, et al.). Each site should use their hospital calculated therapeutic range.

---

Stage	Description	Anti factor Xa [u/ml]/PTT	Infusion	Hold heparin	Rate Change [%]	Repeat PTT
I	Initial Dose (first 6 hours)					
	Infant < 12 mo		15 IU/kg/h			
	Child ≥12mo		10 IU/kg/h			
II	Therapeutic Dose					
	Infant < 12 mo		28 IU/kg/h			after 6h
	Child ≥12mo		20 IU/kg/h			after 6h
III	Adjustment					
		<0.1/<50	0	0	+15%	4h
		0.1-0.34/ 50-60	0	0	+10%	6h
		0.35-0.50/ 60-85	0	0	0	next day
		0.51-0.70/ 86-95			-10%	6h
		0.71-0.89/ 96-120		30 min.	-10 %	4h
		= 0.90/ >120		60 min.	-15 %	4h

Tab. 12-1 Unfractionated Heparin adjusted to maintain an anti factor Xa level of 0.35 to 0.50 U/ml.

Anti Factor Xa level U/ml?	Hold Next Dose?	Dose Change?	Repeat Anti Factor Xa?
< 0.35	no	increase dose by 25 %	4 h after next dose
0.36 - 0.45	no	increase dose by 15 %	4 h after next dose
0.46 - 0.59	no	increase dose by 10 %	4 h after next dose
0.6 - 1.0	no	no	4 h after next dose
1.1 - 1.25	no	decrease dose by 20 %	4 h after next dose
1.26 - 1.5	no	decrease dose by 30 %	4 h after next dose

Tab. 12-2 Enoxaparin, low molecular weight heparin dosing (Monagle, P, et al.)



Anti Factor Xa level U/ml?	Hold Next Dose?	Dose Change?	Repeat Anti Factor Xa?
1.6 - 2.0	yes for 3h	decrease dose by 40 %	Before next dose then 4h after next dose
> 2.0	yes, until anti factor Xa level is <0.5 U/ml	decrease dose by 50%	Before next dose is administered, if >0.5 U/ml (therapeutic level), do not give next enoxaparin dose & repeat anti Xa level in 12 h. When level <0.5 U/ml, administer 50 % original dose.

**Tab. 12-2** Enoxaparin, low molecular weight heparin dosing (Monagle, P, et al.)

Stage	INR	Action
Day 1	1.0 - 1.8	0.2 mg/kg orally
Day 2-4	1.1 - 1.3	repeat day 1 loading dose
	1.4 - 1.9	50 % of day 1 loading dose
	2.0 - 3.0	50 % of day 1 loading dose
	3.1 - 3.5	25 % of day 1 loading dose
	> 3.5	hold dosing until INR is < 3.5

**Tab. 12-3** Warfarin loading dose to maintain an INR of 2.7 - 3.5 (Monagle, P, et al.)

Stage	INR	Action
Maintenance : = Day 5 and long term	1.1 - 1.9	increase dose by 40 -50%
	2.0 - 2.4	increase dose by 10 %
	2.7 - 3.5	no change
	3.6 - 4.0	administer next dose at 50 % then restart at 20 % less maintenance dose
	4.1- 5.0	hold one dose then 20 % less maintenance dose

**Tab. 12-4** Warfarin Maintenance Dosing for Day 5 and longer to maintain INR 2.7-3.5

INR 2.7 to 3.5	use only warfarin p.o.
INR < 2.7	use warfarin plus enoxaparin as outlined in section 5 until INR $\geq$ 2.7

**Tab. 12-5** Drugs and Dose for specific INR range

*This page was left blank intentionally*

## 13 Weaning and Explantation for BTR and BTT

### 13.1 Weaning Procedure

#### 13.1.1 Introduction

This document summarizes the clinical guideline for weaning and explantation of the EXCOR. The decision to wean the EXCOR should be made cautiously after careful review of all available clinical and laboratory data. This document should be considered a guideline only. As always treatment must be individualized to each patient based on his/her unique clinical circumstances.

It is important to recognize that prolonged pump stoppage and operation of the device at lower beat rates is not recommended due to the risks of blood stagnation and thrombus formation. This risk increases with the smaller blood pumps (e.g. 10, 15, 25 and 30 ml devices) where the luminal sizes and flow rates are the lowest. Therefore, a size-based guideline has been developed to test the adequacy of the native circulation without a prolonged pump stoppage using a combination of gradual weaning, brief pump stoppages, careful anticoagulation monitoring, invasive hemodynamic testing, and a brief afterload challenge. It is not recommended that weaning proceed unless all parameters especially those pertaining to anti-coagulation have been fully optimized. This protocol reflects the most recent understanding of the safest possible weaning strategy based on the collective US and European experience to date. Consultation with *Berlin Heart, Inc.* prior to weaning and explantation is strongly recommended.

#### 13.1.2 Indication

Weaning may be considered in children supported with the EXCOR judged to have sufficient evidence of myocardial recovery to provide adequate systemic perfusion independent of VAD support.

#### 13.1.3 Eligibility Criteria



---

Continuous reassessment of eligibility criteria is critical to reducing the risks associated with weaning of VAD support. At all times each of the weaning criteria must be satisfied in order to proceed with the weaning protocol.

---

Special attention must be taken to ensure the patient's anticoagulation status remains within the targeted range.

Weaning of the EXCOR may be considered in subjects who meet the following eligibility criteria:

- LVEDD within normal limits (<98<sup>th</sup> percentile, or Z-score of +2)
- EF = 45% (i.e. no less than mild dysfunction)
- Lactate <3 mmol/L
- No clinical evidence of thromboembolism or bleeding
- Anticoagulation markers within target parameters

### 13.1.4 Weaning Protocol



Rates < 60 bpm are intended to be used only for implantation and explantation. Never use the *Ikus* with a rate < 60 bpm without constant supervision.

If the patient does not meet the eligibility criteria at any time during the weaning process: Resume pumping at rate prior to any weaning (initial rate, IR).

The weaning protocol can be divided into 5 steps and generally takes one week to complete.

- Day 0 (and throughout the weaning process). Confirmation of eligibility criteria for weaning.
- Day 0. Acute weaning challenge
- Day 1-4. Graduated weaning challenge with non-invasive assessment (echo).
- Day 5. Pump stoppage with invasive hemodynamic assessment with afterload challenge.
- Day 6. Pump stoppage with invasive hemodynamic assessment in OR (full anticoagulation).

This size-based weaning protocol accounts for physiologic differences in heart rate and stroke volume observed in children of varying ages.

### 13.1.5 10 ml / 15 ml pump

The individual weaning progress is based upon the following parameters:

Parameter	Explanation	Abbr.	Value
initial rate	rate prior to any weaning	IR	Please enter: IR = _____ bpm
weaning rate	lowest rate achieved during weaning process, depends on pump size	WR	50 bpm
total weaning interval	Difference between initial rate and explantation rate: TWI = IR - WR	TWI	Please enter: IR ___ bpm - WR 50 bpm = TWI ___ bpm
reduced rate	rate resumed at the end of day 1 to 3	RR <sub>1</sub> to RR <sub>3</sub>	Please refer to Tab. 13-2, page 155.

Tab. 13-1 Important parameters for weaning progress

Reduced rate (RR <sub>x</sub> )	Calculation
RR <sub>1</sub>	Please enter: RR <sub>1</sub> = WR 50 bpm + 0.75 x TWI ( ___ bpm) = ___ bpm
RR <sub>2</sub>	Please enter: RR <sub>2</sub> = WR 50 bpm + 0.50 x TWI ( ___ bpm) = ___ bpm
RR <sub>3</sub>	Please enter: RR <sub>3</sub> = WR 50 bpm + 0.25 x TWI ( ___ bpm) = ___ bpm

Tab. 13-2 Reduced rate day 1 to day 3

**10 ml / 15 ml pump Weaning Sequence**

10 ml / 15 ml pump Weaning Sequence		
<b>Day 0</b>	<b>After confirmation of eligibility criteria, the following steps should be performed under echo guidance <sup>1</sup>:</b>	
	<ol style="list-style-type: none"> <li>1. Administer unfractionated heparin (UFH) 75 units/kg x ___ kg = ___ mg IV x 1 [max 5000 units].</li> <li>2. After 5 minutes, reduce the pump rate step-wise from IR (___ bpm) to 30 bpm in increments of 5 bpm q5 min. After 5 minutes at 30 bpm, reassess LV size and function.</li> <li>3. After an additional 5 minutes (i.e. total time = <b>10 min</b> at 30 bpm), stop the pump for <b>3 min</b> and reassess LV size and function. During pump stoppage, use the manual pump to pump twice q30 seconds to minimize the risk of thrombus formation due to blood stagnation while lkus is disconnected.</li> <li>4. After 3-minute pump stop, reconnect pump to lkus and resume pump speed at IR(___ bpm).</li> </ol>	
	<table border="0" style="width: 100%;"> <tr> <td style="width: 70%;"><b>Did the patient satisfy all 5 eligibility criteria throughout the period of weaning and pump stoppage?</b></td> <td style="width: 30%; vertical-align: top;"> <input type="checkbox"/> <b>NO -STOP</b>  <input type="checkbox"/> <b>YES - Proceed</b>  <b>MD _____</b> </td> </tr> </table>	<b>Did the patient satisfy all 5 eligibility criteria throughout the period of weaning and pump stoppage?</b>
<b>Did the patient satisfy all 5 eligibility criteria throughout the period of weaning and pump stoppage?</b>	<input type="checkbox"/> <b>NO -STOP</b> <input type="checkbox"/> <b>YES - Proceed</b> <b>MD _____</b>	

Tab. 13-3 10 ml / 15 ml pump weaning sequence

<b>10 ml / 15 ml pump Weaning Sequence</b>		
<b>Day 1</b>	<p><b>After confirmation of eligibility criteria, the following steps should be performed sequentially under echo guidance <sup>1</sup>:</b></p> <ol style="list-style-type: none"> <li>1. Administer UFH 75 units/kg x _____ kg = _____ mg IV x 1 [max 5000 units].</li> <li>2. After 5 minutes, reduce the pump rate step-wise by from the IR (_____ bpm) to 30 bpm in increments of 5 bpm q 5 min. After 5 minutes at 30 bpm, reassess LV size and function.</li> <li>3. After a total time of <b>10 min</b> at 30 bpm, stop the pump for <b>3 min</b> and reassess LV size and function. During pump stoppage, use the manual pump to pump twice q30 seconds to minimize the risk of thrombus formation due to blood stagnation while Ikus is disconnected.</li> <li>4. After 3-minute pump stop, reconnect pump to Ikus and resume pumping at rate RR1 (___ bpm).</li> </ol>	
	<p><b>Did the patient satisfy all 5 eligibility criteria throughout the period of weaning and pump stoppage?</b></p>	<p><input type="checkbox"/> <b>NO -STOP</b></p> <p><input type="checkbox"/> <b>YES - Proceed</b></p> <p><b>MD _____</b></p>
	<p><b>After confirmation of eligibility criteria, the following steps should be performed under echo guidance <sup>1</sup>:</b></p> <ol style="list-style-type: none"> <li>1. Administer UFH 75 units/kg x _____ kg = _____ mg IV x 1 [max 5000 units].</li> <li>2. After 5 minutes, reduce the pump rate step-wise from RR1 (_____ bpm) to 30 bpm in increments of 5 bpm q 5 min. After 5 minutes at 30 bpm, reassess LV size and function.</li> <li>3. After a total time of <b>20 min</b> at 30 bpm, stop the pump for <b>3 min</b> and reassess LV size and function. During pump stoppage, use the manual pump to pump twice q30 seconds to minimize the risk of thrombus formation due to blood stagnation while Ikus is disconnected.</li> <li>4. After 3-minute pump stop, reconnect pump to Ikus and resume pumping at RR2 (___ bpm).</li> </ol>	
<b>Day 2</b>	<p><b>Did the patient satisfy all 5 eligibility criteria throughout the period of weaning and pump stoppage?</b></p>	<p><input type="checkbox"/> <b>NO -STOP</b></p> <p><input type="checkbox"/> <b>YES - Proceed</b></p> <p><b>MD _____</b></p>

Tab. 13-3 10 ml / 15 ml pump weaning sequence

<b>10 ml / 15 ml pump Weaning Sequence</b>	
<b>Day 3</b>	<p><b>After confirmation of eligibility criteria, the following steps should be performed under echo guidance <sup>1</sup>:</b></p> <ol style="list-style-type: none"> <li>Administer UFH 75 units/kg x _____ kg = _____ mg IV x 1 [max 5000 units].</li> <li>After 5 minutes, reduce the pump rate step-wise from RR2 (____ bpm) to 30 bpm in increments of 5 bpm q 5 min. After 5 minutes at 30 bpm, reassess LV size and function.</li> <li>Initiate exercise with gentle age-appropriate play tasks (e.g. rattle, clapping) as clinically appropriate, where possible</li> <li>After a total time of <b>30 min</b> at 30 bpm, stop the pump for <b>3 min</b> and reassess LV size and function. During pump stoppage, use the manual pump to pump twice q30 seconds to minimize the risk of thrombus formation due to blood stagnation while Ikus is disconnected. After 3-minute pump stop, reconnect pump to Ikus and resume pumping at RR3 (____ bpm).</li> </ol>
	<p><b>Did the patient satisfy all 5 eligibility criteria throughout the period of weaning and pump stoppage?</b></p> <p style="text-align: right;"> <input type="checkbox"/> <b>NO -STOP</b>  <input type="checkbox"/> <b>YES - Proceed</b>  <b>MD</b>_____ </p>
<b>Day 4</b>	<p><b>After confirmation of eligibility criteria, the following steps should be performed under echo guidance <sup>1</sup>:</b></p> <ol style="list-style-type: none"> <li>Administer UFH 75 units/kg x _____ kg = _____ mg IV x 1 [max 5000 units].</li> <li>After 5 minutes, reduce pump rate step-wise from RR3 (____ bpm) to 30 bpm in increments of 5 bpm q 5 min. After 5 minutes at 30 bpm, reassess LV size and function.</li> <li>Initiate exercise with gentle age-appropriate play tasks (e.g. rattle, clapping) as clinically appropriate, where possible.</li> <li>After a total time of <b>30 min</b> at 30 bpm, stop the pump for <b>3 min</b> and reassess LV size and function. During pump stoppage, use the manual pump to pump twice q30 seconds to minimize the risk of thrombus formation due to blood stagnation while Ikus is disconnected.</li> <li>After a 3-minute pump stop: If the patient meets all eligibility criteria, reconnect pump to Ikus and resume pumping at WR (50 bpm). If the patient does not meet all criteria, reconnect Ikus and resume pumping at IR.</li> </ol>
	<p><b>Did the patient satisfy all 5 eligibility criteria throughout the period of weaning and pump stoppage?</b></p> <p style="text-align: right;"> <input type="checkbox"/> <b>NO -STOP</b>  <input type="checkbox"/> <b>YES - Proceed</b>  <b>MD</b>_____ </p>

Tab. 13-3 10 ml / 15 ml pump weaning sequence

10 ml / 15 ml pump Weaning Sequence	
<b>Day 5</b>	<p><b>After confirmation of eligibility criteria, the following steps should be performed in the cath lab under echo guidance <sup>1</sup>:</b></p> <ol style="list-style-type: none"> <li>1. Obtain standard access for RHC (if possible with out sedation).</li> <li>2. Administer UFH 75 units/kg x _____ kg = _____ mg IV x 1 [max 5000 units].</li> <li>3. After 5 minutes, reduce the pump rate step-wise from WR (50 bpm) to 30 bpm in increments of 5 bpm q5 min. After 5 minutes at 30 bpm, reassess LV size and function.</li> <li>4. After a total time of <b>10 min</b> at 30 bpm, stop the pump for <b>3 min</b> and reassess LV size and function. During pump stoppage, use the manual pump to pump twice q30 seconds to minimize the risk of thrombus formation due to blood stagnation while Ikus is disconnected.</li> <li>5. After 3 minutes, initiate norepinephrine infusion at 0.01 mcg/kg/min IV gtt titrated to MAP 20% above baseline x 5 min. While doing so, proceed pumping manually twice q30 seconds.</li> <li>6. If LV size and function acceptable, proceed pumping manually twice q30 seconds for <b>3 min</b>. While doing so, reassess LV size &amp; function, and record RAP, PAP, PCWP and MVS.</li> <li>7. After 6-minute pump stop: If the patient meets all eligibility criteria, reconnect pump to Ikus and resume pumping at 50 bpm until the actual surgical procedure of explantation takes place. If the patient does not meet all criteria, reconnect Ikus and resume pumping at IR.</li> </ol>
	<p><b>Did the patient satisfy all 5 eligibility criteria throughout the period of weaning and pump stoppage?</b></p>
	<p><input type="checkbox"/> <b>NO -STOP</b>  <input type="checkbox"/> <b>YES - Proceed</b>  <b>MD _____</b></p>

Tab. 13-3 10 ml / 15 ml pump weaning sequence

<sup>1</sup> TEE unless echo windows insufficient. The last weaning increment may be less than 5 bpm if the wean interval is not a multiple of 5.

### 13.1.6 25 / 30 ml pump

The individual weaning progress is based upon the following parameters:

Parameter	Explanation	Abbr.	Value
initial rate	rate prior to any weaning	IR	Please enter:
weaning rate	lowest rate achieved during weaning process, depends on pump size	WR	40 bpm

Tab. 13-4 Important parameters for weaning progress



Parameter	Explanation	Abbr.	Value
total weaning interval	Difference between initial rate and explanation rate: $TWI = IR - WR$	TWI	Please enter: IR ___ bpm - WR 40 bpm = TWI ___ bpm
reduced rate	rate resumed at the end of day 1 to 3	RR <sub>1</sub> to RR <sub>3</sub>	Please refer Tab. 13-5, page 159.

Tab. 13-4 Important parameters for weaning progress

Reduced rate (RR <sub>x</sub> )	Calculation
RR <sub>1</sub>	Please enter: $RR_1 = WR 40 \text{ bpm} + 0.75 \times TWI (\text{ ___ bpm}) = \text{ ___ bpm}$
RR <sub>2</sub>	Please enter: $RR_2 = WR 40 \text{ bpm} + 0.50 \times TWI (\text{ ___ bpm}) = \text{ ___ bpm}$
RR <sub>3</sub>	Please enter: $RR_3 = WR 40 \text{ bpm} + 0.25 \times TWI (\text{ ___ bpm}) = \text{ ___ bpm}$

Tab. 13-5 Reduced rate day 1 to day 3

### 25 / 30 ml pump Weaning Sequence

25 / 30 ml pump Weaning Sequence	
<b>Day 0</b>	<b>After confirmation of eligibility criteria, the following steps should be performed under echo guidance:<sup>1</sup></b>
	<ol style="list-style-type: none"> <li>Administer unfractionated heparin (UFH) 75 units/kg x ___ kg = ___ mg IV x 1 [max 5000 units].</li> <li>After 5 minutes, reduce the pump rate step-wise from IR (___ bpm) to 30 bpm in increments of 5 bpm q5 min. After 5 minutes at 30 bpm, reassess LV size and function.</li> <li>After an additional 5 minutes (i.e. total time = 10 min at 30 bpm), stop the pump for 5 min and reassess LV size and function. During pump stoppage, use the manual pump to pump twice q30 seconds to minimize the risk of thrombus formation due to blood stagnation while Ikus is disconnected.</li> <li>After 5-minute pump stop, reconnect pump to Ikus and resume pump speed at IR(___ bpm).</li> </ol>
	Did the patient satisfy all 5 eligibility criteria throughout the period of weaning and pump stoppage? <div style="float: right;"> <input type="checkbox"/> <b>NO - STOP</b>  <input type="checkbox"/> <b>YES - Proceed</b>  <b>MD _____</b> </div>

Tab. 13-6 25 / 30 ml pump Weaning Sequence

<b>25 / 30 ml pump Weaning Sequence</b>		
<b>Day 1</b>	<p><b>After confirmation of eligibility criteria, the following steps should be performed sequentially under echo guidance:<sup>1</sup></b></p> <ol style="list-style-type: none"> <li>1. Administer UFH 75 units/kg x _____ kg = _____ mg IV x 1 [max 5000 units].</li> <li>2. After 5 minutes, reduce the pump rate step-wise by from the IR (_____ bpm) to 30 bpm in increments of 5 bpm q 5 min. After 5 minutes at 30 bpm, reassess LV size and function.</li> <li>3. After a total time of <b>10 min</b> at 30 bpm, stop the pump for <b>5 min</b> and reassess LV size and function. During pump stoppage, use the manual pump to pump twice q30 seconds to minimize the risk of thrombus formation due to blood stagnation while Ikus is disconnected.</li> <li>4. After 5-minute pump stop, reconnect pump to Ikus and resume pumping at rate RR1 (___ bpm).</li> </ol>	
	<p><b>Did the patient satisfy all 5 eligibility criteria throughout the period of weaning and pump stoppage?</b></p>	<p><input type="checkbox"/> <b>NO - STOP</b></p> <p><input type="checkbox"/> <b>YES - Proceed</b></p> <p><b>MD</b> _____</p>
	<p><b>After confirmation of eligibility criteria, the following steps should be performed under echo guidance:<sup>1</sup></b></p> <ol style="list-style-type: none"> <li>1. Administer UFH 75 units/kg x _____ kg = _____ mg IV x 1 [max 5000 units].</li> <li>2. After 5 minutes, reduce the pump rate step-wise from RR1 (_____ bpm) to 30 bpm in increments of 5 bpm q 5 min. After 5 minutes at 30 bpm, reassess LV size and function.</li> <li>3. After a total time of <b>20 min</b> at 30 bpm, stop the pump for <b>10 min</b> and reassess LV size and function. During pump stoppage, use the manual pump to pump twice q30 seconds to minimize the risk of thrombus formation due to blood stagnation while Ikus is disconnected.</li> <li>4. After 10-minute pump stop, reconnect pump to Ikus and resume pumping at RR2 (___ bpm).</li> </ol>	
<b>Day 2</b>	<p><b>Did the patient satisfy all 5 eligibility criteria throughout the period of weaning and pump stoppage?</b></p>	<p><input type="checkbox"/> <b>NO - STOP</b></p> <p><input type="checkbox"/> <b>YES - Proceed</b></p> <p><b>MD</b> _____</p>

Tab. 13-6 25 / 30 ml pump Weaning Sequence

<b>25 / 30 ml pump Weaning Sequence</b>	
<b>Day 3</b>	<p><b>After confirmation of eligibility criteria, the following steps should be performed under echo guidance:<sup>1</sup></b></p> <ol style="list-style-type: none"> <li>Administer UFH 75 units/kg x _____ kg = _____ mg IV x 1 [max 5000 units].</li> <li>After 5 minutes, reduce the pump rate step-wise from RR2 (___ bpm) to 30 bpm in increments of 5 bpm q 5 min. After 5 minutes at 30 bpm, reassess LV size and function.</li> <li>Initiate exercise with gentle age-appropriate play tasks (e.g. patty cake) as clinically appropriate, where possible</li> <li>After a total time of <b>30 min</b> at 30 bpm, stop the pump for <b>10 min</b> and reassess LV size and function. During pump stoppage, use the manual pump to pump twice q30 seconds to minimize the risk of thrombus formation due to blood stagnation while lkus is disconnected.</li> <li>After 10-minute pump stop, reconnect pump to lkus and resume pumping at RR3 (___ bpm).</li> </ol>
	<p><b>Did the patient satisfy all 5 eligibility criteria throughout the period of weaning and pump stoppage?</b></p> <p style="text-align: right;"> <input type="checkbox"/> <b>NO - STOP</b>  <input type="checkbox"/> <b>YES - Proceed</b>  <b>MD _____</b> </p>
<b>Day 4</b>	<p><b>After confirmation of eligibility criteria, the following steps should be performed under echo guidance:<sup>1</sup></b></p> <ol style="list-style-type: none"> <li>Administer UFH 75 units/kg x _____ kg = _____ mg IV x 1 [max 5000 units].</li> <li>After 5 minutes, reduce pump rate step-wise from RR<sub>3</sub> (___ bpm) to 30 bpm in increments of 5 bpm q 5 min. After 5 minutes at 30 bpm, reassess LV size and function.</li> <li>Initiate exercise with gentle age-appropriate play tasks (e.g. patty cake) as clinically appropriate, where possible.</li> <li>After a total time of <b>30 min</b> at 30 bpm, stop the pump for <b>15 min</b> and reassess LV size and function. During pump stoppage, use the manual pump to pump twice q30 seconds to minimize the risk of thrombus formation due to blood stagnation while lkus is disconnected.</li> <li>After a 15-minute pump stop: If the patient meets all eligibility criteria, reconnect pump to lkus and resume pumping at WR (40 bpm). If the patient does not meet all criteria, reconnect lkus and resume pumping at IR.</li> </ol>
	<p><b>Did the patient satisfy all 5 eligibility criteria throughout the period of weaning and pump stoppage?</b></p> <p style="text-align: right;"> <input type="checkbox"/> <b>NO - STOP</b>  <input type="checkbox"/> <b>YES - Proceed</b>  <b>MD _____</b> </p>

Tab. 13-6 25 / 30 ml pump Weaning Sequence

25 / 30 ml pump Weaning Sequence	
<b>Day 5</b>	<p><b>After confirmation of eligibility criteria, the following steps should be performed in the cath lab under echo guidance:<sup>1</sup></b></p> <ol style="list-style-type: none"> <li>1. Obtain standard access for RHC (if possible with out sedation).</li> <li>2. Administer UFH 75 units/kg x _____ kg = _____ mg IV x 1 [max 5000 units].</li> <li>3. After 5 minutes, reduce the pump rate step-wise from WR (50 bpm) to 30 bpm in increments of 5 bpm q5 min. After 5 minutes at 30 bpm, reassess LV size and function.</li> <li>4. After a total time of <b>30 min</b> at 30 bpm, stop the pump for <b>15 min</b> and reassess LV size and function. During pump stoppage, use the manual pump to pump twice q30 seconds to minimize the risk of thrombus formation due to blood stagnation while lkus is disconnected.</li> <li>5. After 15 minutes, initiate norepinephrine infusion at 0.01 mcg/kg/min IV gtt titrated to MAP 20% above baseline x 5 min. While doing so, proceed pumping manually twice q30 seconds.</li> <li>6. If LV size and function acceptable, proceed pumping manually twice q30 seconds for <b>5 min</b>. While doing so, reassess LV size &amp; function, and record RAP, PAP, PCWP and MVS.</li> <li>7. After 20-minute pump stop: If the patient meets all eligibility criteria, reconnect pump to lkus and resume pumping at 50 bpm until the actual surgical procedure of explantation takes place. If the patient does not meet all criteria, reconnect lkus and resume pumping at IR.</li> </ol>
	<p><b>Did the patient satisfy all 5 eligibility criteria throughout the period of weaning and pump stoppage?</b></p>
	<p><input type="checkbox"/> <b>NO - STOP</b>  <input type="checkbox"/> <b>YES - Proceed</b>  <b>MD _____</b></p>

Tab. 13-6 25 / 30 ml pump Weaning Sequence

<sup>1</sup> TEE unless echo windows insufficient. The last weaning increment may be less than 5 bpm if the wean interval is not a multiple of 5.

### 13.1.7 50 / 60 ml pump

The individual weaning progress is based upon the following parameters:

Parameter	Explanation	Abbr.	Value
initial rate	rate prior to any weaning	IR	Please enter: IR = _____ bpm
weaning rate	lowest rate achieved during weaning process, depends on pump size	WR	30 bpm

Tab. 13-7 Important parameters for weaning progress

Parameter	Explanation	Abbr.	Value
total weaning interval	Difference between initial rate and explanation rate: $TWI = IR - WR$	TWI	Please enter: $IR \text{ ___ bpm} - WR \text{ 30 bpm} =$ $TWI \text{ ___ bpm}$
reduced rate	rate resumed at the end of day 1 to 3	$RR_1$ to $RR_3$	Please refer to Tab. 13-8, page 163.

Tab. 13-7 Important parameters for weaning progress

Reduced rate ( $RR_x$ )	Calculation
$RR_1$	Please enter: $RR_1 = WR \text{ 30 bpm} + 0.75 \times TWI \text{ ( ___ bpm)} = \text{ ___ bpm}$
$RR_2$	Please enter: $RR_2 = WR \text{ 30 bpm} + 0.50 \times TWI \text{ ( ___ bpm)} = \text{ ___ bpm}$
$RR_3$	Please enter: $RR_3 = WR \text{ 30 bpm} + 0.25 \times TWI \text{ ( ___ bpm)} = \text{ ___ bpm}$

Tab. 13-8 Reduced rate day 1 to day 3

**50 / 60 ml pump Weaning Sequence**

50 / 60 ml pump Weaning Sequence	
<b>Day 0</b>	<b>After confirmation of eligibility criteria, the following steps should be performed under echo guidance:<sup>1</sup></b>
	<ol style="list-style-type: none"> <li>1. Administer unfractionated heparin (UFH) 75 units/kg x ___ kg = ___ mg IV x 1 [max 5000 units].</li> <li>2. After 5 minutes, reduce the pump rate step-wise from IR (___ bpm) to 30 bpm in increments of 5 bpm q5 min. After 5 minutes at 30 bpm, reassess LV size and function.</li> <li>3. After an additional 5 minutes (i.e. total time = 10 min at 30 bpm), stop the pump for 5 min and reassess LV size and function. During pump stoppage, use the manual pump to pump twice q30 seconds to minimize the risk of thrombus formation due to blood stagnation while Ikus is disconnected.</li> <li>4. After 5-minute pump stop, reconnect pump to Ikus and resume pump speed at IR(___ bpm).</li> </ol>
	Did the patient satisfy all 5 eligibility criteria throughout the period of weaning and pump stoppage? <div style="float: right;"> <input type="checkbox"/> <b>NO - STOP</b>  <input type="checkbox"/> <b>YES - Proceed</b>  <b>MD _____</b> </div>

Tab. 13-9 50 / 60 ml pump Weaning Sequence

<b>50 / 60 ml pump Weaning Sequence</b>		
<b>Day 1</b>	<p><b>After confirmation of eligibility criteria, the following steps should be performed sequentially under echo guidance:<sup>1</sup></b></p> <ol style="list-style-type: none"> <li>1. Administer UFH 75 units/kg x _____ kg = _____ mg IV x 1 [max 5000 units].</li> <li>2. After 5 minutes, reduce the pump rate step-wise by from the IR (_____ bpm) to 30 bpm in increments of 5 bpm q 5 min. After 5 minutes at 30 bpm, reassess LV size and function.</li> <li>3. After a total time of <b>10 min</b> at 30 bpm, stop the pump for <b>10 min</b> and reassess LV size and function. During pump stoppage, use the manual pump to pump twice q30 seconds to minimize the risk of thrombus formation due to blood stagnation while Ikus is disconnected.</li> <li>4. After 10-minute pump stop, reconnect pump to Ikus and resume pumping at rate RR1 (___ bpm).</li> </ol>	
	<p><b>Did the patient satisfy all 5 eligibility criteria throughout the period of weaning and pump stoppage?</b></p>	<p><input type="checkbox"/> <b>NO - STOP</b></p> <p><input type="checkbox"/> <b>YES - Proceed</b></p> <p><b>MD</b>_____</p>
	<p><b>After confirmation of eligibility criteria, the following steps should be performed under echo guidance:<sup>1</sup></b></p> <ol style="list-style-type: none"> <li>1. Administer UFH 75 units/kg x _____ kg = _____ mg IV x 1 [max 5000 units].</li> <li>2. After 5 minutes, reduce the pump rate step-wise from RR1 (_____ bpm) to 30 bpm in increments of 5 bpm q 5 min. After 5 minutes at 30 bpm, reassess LV size and function.</li> <li>3. After a total time of <b>15 min</b> at 30 bpm, stop the pump for <b>15 min</b> and reassess LV size and function. During pump stoppage, use the manual pump to pump twice q30 seconds to minimize the risk of thrombus formation due to blood stagnation while Ikus is disconnected.</li> <li>4. After 15-minute pump stop, reconnect pump to Ikus and resume pumping at RR2 (___ bpm).</li> </ol>	
<b>Day 2</b>	<p><b>Did the patient satisfy all 5 eligibility criteria throughout the period of weaning and pump stoppage?</b></p>	<p><input type="checkbox"/> <b>NO - STOP</b></p> <p><input type="checkbox"/> <b>YES - Proceed</b></p> <p><b>MD</b>_____</p>

Tab. 13-9 50 / 60 ml pump Weaning Sequence

<b>50 / 60 ml pump Weaning Sequence</b>		
<b>Day 3</b>	<p><b>After confirmation of eligibility criteria, the following steps should be performed under echo guidance:<sup>1</sup></b></p> <ol style="list-style-type: none"> <li>Administer UFH 75 units/kg x _____ kg = _____ mg IV x 1 [max 5000 units].</li> <li>After 5 minutes, reduce the pump rate step-wise from RR2 (____ bpm) to 30 bpm in increments of 5 bpm q 5 min. After 5 minutes at 30 bpm, reassess LV size and function.</li> <li>Initiate exercise with gentle age-appropriate play tasks (e.g. ambulate) as clinically appropriate, where possible</li> <li>After a total time of <b>30 min</b> at 30 bpm, stop the pump for <b>20 min</b> and reassess LV size and function. During pump stoppage, use the manual pump to pump twice q30 seconds to minimize the risk of thrombus formation due to blood stagnation while lkus is disconnected.</li> <li>After 20-minute pump stop, reconnect pump to lkus and resume pumping at RR3 (____ bpm).</li> </ol>	
	<p><b>Did the patient satisfy all 5 eligibility criteria throughout the period of weaning and pump stoppage?</b></p>	<p><input type="checkbox"/> <b>NO - STOP</b></p> <p><input type="checkbox"/> <b>YES - Proceed</b></p> <p><b>MD _____</b></p>
	<p><b>After confirmation of eligibility criteria, the following steps should be performed under echo guidance:<sup>1</sup></b></p> <ol style="list-style-type: none"> <li>Administer UFH 75 units/kg x _____ kg = _____ mg IV x 1 [max 5000 units].</li> <li>After 5 minutes, reduce pump rate step-wise from RR<sub>3</sub> (____ bpm) to 30 bpm in increments of 5 bpm q 5 min. After 5 minutes at 30 bpm, reassess LV size and function.</li> <li>Initiate exercise with gentle age-appropriate play tasks (e.g. ambulate) as clinically appropriate, where possible.</li> <li>After a total time of <b>30 min</b> at 30 bpm, stop the pump for <b>30 min</b> and reassess LV size and function. During pump stoppage, use the manual pump to pump twice q30 seconds to minimize the risk of thrombus formation due to blood stagnation while lkus is disconnected.</li> <li>After a 15-minute pump stop: If the patient meets all eligibility criteria, reconnect pump to lkus and resume pumping at WR (40 bpm). If the patient does not meet all criteria, reconnect lkus and resume pumping at IR.</li> </ol>	
<b>Day 4</b>	<p><b>Did the patient satisfy all 5 eligibility criteria throughout the period of weaning and pump stoppage?</b></p>	<p><input type="checkbox"/> <b>NO - STOP</b></p> <p><input type="checkbox"/> <b>YES - Proceed</b></p> <p><b>MD _____</b></p>

Tab. 13-9 50 / 60 ml pump Weaning Sequence

<b>50 / 60 ml pump Weaning Sequence</b>		
<b>Day 5</b>	<b>After confirmation of eligibility criteria, the following steps should be performed in the cath lab under echo guidance<sup>1</sup></b>	
	<ol style="list-style-type: none"> <li>1. Obtain standard access for RHC (if possible with out sedation).</li> <li>2. Administer UFH 75 units/kg x _____ kg = _____ mg IV x 1 [max 5000 units].</li> <li>3. Assess LV size and function to obtain data for comparison.</li> <li>4. Stop the pump for <b>15 min</b> and reassess LV size and function. During pump stoppage, use the manual pump to pump twice q30 seconds to minimize the risk of thrombus formation due to blood stagnation while lkus is disconnected.</li> <li>5. After 15 minutes, initiate norepinephrine infusion at 0.01 mcg/kg/min IV gtt titrated to MAP 20% above baseline x 5 min. While doing so, proceed pumping manually twice q30 seconds.</li> <li>6. If LV size and function acceptable, proceed pumping manually twice q30 seconds for <b>15 min</b>. While doing so, reassess LV size &amp; function, and record RAP, PAP, PCWP and MVS.</li> <li>7. After 30-minute pump stop: If the patient meets all eligibility criteria, reconnect pump to lkus and resume pumping at 50 bpm until the actual surgical procedure of explantation takes place. If the patient does not meet all criteria, reconnect lkus and resume pumping at IR.</li> </ol>	
	<table border="0" style="width: 100%;"> <tr> <td style="width: 70%;"><b>Did the patient satisfy all 5 eligibility criteria throughout the period of weaning and pump stoppage?</b></td> <td style="width: 30%; vertical-align: top;"> <input type="checkbox"/> <b>NO - STOP</b>  <input type="checkbox"/> <b>YES - Proceed</b>  <b>MD _____</b> </td> </tr> </table>	<b>Did the patient satisfy all 5 eligibility criteria throughout the period of weaning and pump stoppage?</b>
<b>Did the patient satisfy all 5 eligibility criteria throughout the period of weaning and pump stoppage?</b>	<input type="checkbox"/> <b>NO - STOP</b> <input type="checkbox"/> <b>YES - Proceed</b> <b>MD _____</b>	

Tab. 13-9 50 / 60 ml pump Weaning Sequence

<sup>1</sup> TEE unless echo windows insufficient. The last weaning increment may be less than 5 bpm if the wean interval is not a multiple of 5.

### 13.1.8 Explantation Criteria

**NOTICE**

ASA and dipyridamole should be discontinued 24-hours prior to device explantation; coumadin/Enoxaparin should be transitioned back to unfractionated heparin (titrated to therapeutic levels).

Milrinone 0.75 µg/kg/min should be started 12 hours prior explantation. ACE inhibitor, β-Blocker and Spirinolactone should be not stopped.



In the operating room, explantation should be considered if the following criteria are met with the pump stopped for 20 minutes (after anticoagulation has been established in the target range for cardiopulmonary bypass):

- LVEDD less than 98th percentile (Z-score less than +2)
- EF  $\geq$  45 % (i.e. no more than mild ventricular dysfunction)
- Normotensive on only Milrinone (no other inotropes)
- Lactate  $<$ 3 mmol/L
- LVEDP  $<$  12 mmHg
- Resting CI of  $>$  2.8 L/min/m<sup>2</sup>

Surgery should be performed without Cardiopulmonary Bypass. Control all bleeding immediately during and post implantation.

## 13.2 Explantation for BTR

### 13.2.1 Explantation with univentricular support

The procedure is analogous to that used after BTT (see section 13.3: Explantation for BTT, page 168). Sew over all anastomosis areas where cannulae were placed.

### 13.2.2 Explantation after biventricular support

#### Stopping the right pump

##### ► INSTRUCTION

1. Select **Pause right** (see Fig. 13-1, page 167), then press **<Enter>** to confirm. Respond to the prompt in the dialog window by pressing the **<X>** key or the **<1>** key. The right pump will stop. The view Pump size and single-step mode is shown (see Fig. 7-7, page 100). The cursor is located on the **OK** field.
2. Unplug the driving tube of the right pump from the connector on the Ikus. Use the seal plug to seal the connector.
3. To confirm the **OK** selection, press **<Enter>**. The Ikus continues running. The screen shows the standard view.

Parameter	Operation	Pressure [mmHg]		Rate	% Systole
		Normal	Systole		
Left	L		200.0	0.0	40.0
Right	R		170.0	0.0	40.0

Buttons at the bottom: Alarm off, L/R separate, **Pause right** (highlighted), Log off

Fig. 13-1 Pause right

#### Switching the Ikus off



The Ikus power switch (toggle switch) should always be in the [I] position, even if the main switch (key switch) is in the [O] position!. Otherwise there is a risk that the drive may fail in future due to the Ikus batteries being totally discharged.

Always follow the above sequence of operations. Always use the key switch to switch off the Ikus.

---

Do not switch the Ikus off unless the batteries are fully charged. Leave the Ikus switched on until all yellow LEDs light up, then switch off the Ikus with main switch (key switch).

---

---

Keep all driving tube connectors covered at all times when not in use.

---

**➤ INSTRUCTION**

1. Put the patient on cardiopulmonary bypass (CPB).
2. Disconnect the driving tubes and connect both tank units to the Ikus.
3. Leave the Ikus running with the tank units until the patient is stable on CPB and the blood pumps have been explanted.
4. Next in the monitor program, select the option **Drive OFF** (see Fig. 13-2, page 169) and press **<Enter>** to confirm.
5. Respond to the prompt in the dialog window by pressing the **<X>** key or the **<1>** key. The system stops operation immediately and writes an operating log.
6. Disconnect the driving tube(s) from the connector(s). To do so, take hold of the plug's release sleeve and pull the plug out of the connector.
7. Use the seal plugs to seal the driving tube connector sockets.
8. Wait until the log has been completed. When the message **Switch drive off with main switch!** appears, press **<F10>** to shut down the monitor program. Confirm by pressing the **<X>** key or the **<1>** key.
9. Select **3. End (<3>**, see Fig. 13-3, page 169) in the start menu and switch off the laptop.
10. Switch the Ikus off, provided that the batteries are fully charged. To do so, turn the key switch to **[0]** position.

### 13.3 Explantation for BTT

**NOTICE**

---

When planning and timing the transplantation, be aware that massive adhesions may exist in the transplant recipient.

---

#### Preparing the donor organ

**ADVICE**

---

Leave adequate lengths of the aorta and the pulmonary artery attached to the donor organ in order to be able to continue using those parts of the original vessels used for anastomosis of the VAD cannulae.

---

---

Leave the Ikus running with the tank units until the patient is stable on CPB and the blood pumps have been explanted.

---

#### Switching the Ikus off

**WARNING**

---

The Ikus power switch (toggle switch) should always be in the **[I]** position, even if the main switch (key switch) is in the **[0]** position! Otherwise there is a risk that the drive may fail due to the Ikus batteries being totally discharged.

---



Always follow the above sequence of operations. Always use the key switch to switch off the Ikus.

Do not switch the Ikus off unless the batteries are fully charged. To do this leave the Ikus switched on until all yellow LEDs light up, then switch the Ikus off using the key switch.

### INSTRUCTION

1. Put the patient on cardiopulmonary bypass.
2. Disconnect the driving tubes and connect both tank units to the Ikus.
3. Leave the Ikus running with the tank units until the patient is stable on CPB and the blood pumps have been explanted.
4. Next in the monitor program, select the Drive OFF option and press <Enter> to confirm (see Fig. 13-2, page 169).
5. Respond to the prompt in the dialog window by pressing the <X> key or the <1> key. The system stops operation immediately and writes an operating log.
6. Disconnect the driving tube(s) from the connector(s). To do so, take hold of the release sleeve and pull this out of the connector.
7. Use the seal plugs to seal the driving tube connectors.
8. Wait until the log has been completed. When the message Switch drive off with main switch! appears, press <F10> to shut down the monitor program. Confirm by pressing the <X> key or the <1> key.
9. Select 3. End (<3>, see Fig. 13-3, page 169) in the start menu and switch off the laptop.
10. Switch the Ikus off, provided that the batteries are fully charged. To do so, turn the key switch to [0] position.

Parameter	Operation	Pressure [mmHg]		Rate	% Systole
		Normal	Systole		
Left	L		200.0	0.0	40.0
Right	R		170.0	0.0	40.0

Alarm off	L/R separate	Drive OFF	Log off
-----------	--------------	-----------	---------

Fig. 13-2 Drive OFF

```

1. Start Program
2. Entry codes
3. End
4. Save data
5. Change date or time
6. Change language

Input:

```

Fig. 13-3 Start menu

### Removing the VAD cannulae

**➤ INSTRUCTION**

1. Clamp off the cannulae.
2. Disconnect the pump from the cannulae.
3. Remove the cannulae. Sew over the anastomosis areas of the atrium.

The remaining procedure is the same as for any primary orthotopic heart transplantation.

# 14 Error Messages and corrective measures

This chapter describes all IkuS error messages and explains what measures should be taken if an error does occur.

Whenever a message is displayed, always follow the exact instructions provided in this instruction for use.

Keep calm!

It is necessary to be very observant as long as the cause of a message has not been corrected.

IkuS treats all error messages with the same priority.

 **HOTLINE**

**Notify Berlin Heart! 866.249.0128**

**NOTICE**

Some errors immediately re-trigger an alarm as long as they are still active even after being acknowledged on the laptop. Also in this case first mute the alarm on the handle in order to prevent permanent retriggering of the acoustic alarm. Before acknowledging the alarm wait for the error message and then take appropriate action.

## When an error message occurs, the following happens:

- An acoustic signal (2 different beep sounds) is emitted.
- The indicator light on the control panel of the handle lights up.
- A red border is shown around the field **Alarm off** in the monitor program display.
- In the message window of the monitor program, a text is displayed informing about the time of occurrence, the type of fault and the corrective measures which must be taken. **IMPORTANT:** Always observe the instructions! In addition, some of the more complex error messages contain an 8- or 16-digit binary code which enables the service department to identify the exact cause of the fault.

## What to do when an error message is shown

### INSTRUCTION

1. Check the status of the patient.
2. Observe the filling and ejection behavior of the blood pump (visual check) over several pump cycles!
3. Carry out the appropriate measures and acknowledge the message.

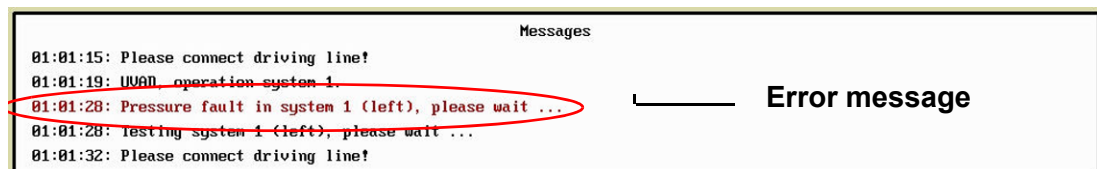

Fig. 14-1 Example of an error message in the message window

### Acknowledging an error message



Messages are only displayed when the monitor program is running. When the monitor program is shut down, the only indications that there is an error message are an acoustic signal and the fact that the indicator lamp on the Ikus handle lights up. There is no way of finding out what type of error message has been displayed.

If the monitor program has been shut down, no data on current events are recorded and the LOG files will be incomplete. Therefore do not shut down the monitor program unless this is absolutely necessary (e. g. if it is necessary to set up new user profiles)! Restart the monitor program as soon as possible after this!

The monitor program shows some of the error messages with an additional reference to system 1, 2 or 3. The system descriptions left and right refer to the internal arrangement of the pneumatic systems and not to the left or right pump.

This refers to the following connections specifically:

- system 1 (left): the system connected to the red connector
- system 2 (right): the system connected to the blue connector
- system 3 (backup): backup system

All messages, together with their time of occurrence, are recorded in the log file. In the case of some messages, the cause of the fault may correct itself automatically after a short time. In this case, a corresponding message is shown (e. g. **Please check left driving tube and pump or Left: driving tube/ pump OK**).

#### INSTRUCTION

1. Press the *mute button* on the control panel of the handle to mute the error message. This switches off the acoustic signal temporarily. The **Alarm off** field lights up red in the monitor program.
2. Read the displayed message(s) carefully. Observe the instructions provided in the message text.
3. Take corrective measures immediately!
4. Acknowledge the message in the monitor program. To do so, move the cursor to the Alarm off field and then press <Enter> to confirm. Otherwise the acoustic alarm will sound again after 10 minutes at latest. Exceptional cases: section 14.4: Please check left / right pump and driving tube, page 175 and section 14.14: Temperature sensors: <<8-digit binary code>>, page 181.

Message	Duration of muting:
<b>Please connect driving tube!</b>	10 s + 8 cycle s (systole + diastole)
<b>Please check left / right pump and driving tube!</b>	1 min
<b>Batteries discharged - use power supply!</b>	max. 1 min
Any other message	10 min

Tab. 14-1 Duration of muting

## 14.1 Pressure error / time error in system 1 (or in system 2 or 3)

- [Pressure fault in system 1 \(left\), please wait ...](#)
- [Pressure fault in system 2 \(right\), please wait ...](#)
- [Pressure fault in system 3 \(backup\), please wait ...](#)
- [Time error system 1 \(left\), please wait ...](#)
- [Time error system 2 \(right\), please wait ...](#)
- [Time error system 3 \(backup\), please wait ...](#)

The air volume pumped per cycle by the Ikus or the pressure required to pump it has changed. The Ikus checks whether there is an internal system fault (e. g. a compressor has broken down) or whether there is an external error (e. g. driving tube not connected or driving tube leak).



**WARNING**

---

The blood pump of the corresponding system is stopped for the duration of this test (for approx. 10 seconds).

---

### If the Ikus has detected a pneumatic system fault...

the Ikus switches to backup operation and the message Backup operation left/right. Contact customer service. is shown (see section 14.5: Backup operation left/right, page 176), together with a request to inform the service department.



**HOTLINE**

---

**Notify Berlin Heart! 866.249.0128**

---

### If the Ikus has detected an external fault ...

it displays the message Please connect driving tube! (see section 14.3: Please connect driving tube, page 174). Provide the patient immediately with a replacement Ikus.

### If the main computer and the backup computer arrive at different results in the test phase ...

the backup computer generates the message Backup computer reports faulty test (see section 14.11.4: ... reports faulty test, page 180).

Follow the instructions exactly as described in each section.

## 14.2 Throttle valve error in system 1 (or system 2 or 3)

- [Throttle fault in system 1 \(left\), please wait ...](#)
- [Throttle fault in system 2 \(right\), please wait ...](#)
- [Throttle fault in system 3 \(backup\), please wait ...](#)



**HOTLINE**

---

**Notify Berlin Heart! 866.249.0128**

---

In an active system, the Ikus has detected a throttle valve error (throttle: internal module for pneumatics test) and switches to backup operation (see section 14.5: Backup operation left/right, page 176). Provide the patient immediately with a replacement Ikus. A throttle is an internal assembly for the pneumatic test.

## 14.3 Please connect driving tube

### Please connect driving tube!

#### ➤ INSTRUCTION

1. Inspect the driving tube and the connectors.
2. If a plug is not seated correctly: re-insert it correctly. To do so, grip the release sleeve and pull it out of the connector, then plug it back in. Check that the plug is securely connected. To do so, grip the plug body above the release sleeve and pull on it. Do not pull from the release sleeve, and never from the tube!
3. If the driving tube is defective: replace it.

### 14.3.1 Replacing a driving tube

The driving tubes (red/blue) have a maximum life of 1 year (see section 16.2: Technical specifications, page 217) and must be replaced after 1 year.

#### ⚠ WARNING

In order for a driving tube to be replaced, the pump must be stopped for a short time. If the left driving tube is being replaced in a driving unit providing biventricular support, the right pump must also be stopped while the driving tube is being replaced in order to avoid overloading of the pulmonary circulation (danger of pulmonary edema).

#### Material

- 1 driving tube, red or blue
- 1 tube connecting set (cable tie, cable-tie gun), from accessory set

#### ➤ INSTRUCTION

1. If required log into the monitor program by entering user ID and password and confirm with **<Enter>**.
2. Select the option **Drive pause** and press **<Enter>** to confirm. Respond to the prompt in the dialog window by pressing the **<X>** key or the **<1>** key. The Ikus will stop.
3. Carefully cut the cable tie on the defective driving tube.
4. As soon as the pump has stopped, remove the defective driving tube from the pump.
5. Connect the new driving tube to the blood pump. To do so, carefully push the end of the driving tube onto the driving tube connector.
6. Remove the defective driving tube from the Ikus connector socket. To do so, take hold of the release sleeve and pull this out of the connector.
7. Connect the new driving tube to the connector, which is now free. The sound of the plug snapping into place is clearly audible. Check that the plug is securely connected. To do so, grip the plug body above the release sleeve and pull on it. Do not pull from the release sleeve, and never from the tube!
8. The view *Select operating mode* appears on the monitor. Select **Univentricular (UVAD)** or **Biventricular (BVAD)**, then confirm the selected operating mode with **<Enter>**. In biventricular mode the view *Pump size and single-step mode* appears. In univentricular mode, the connector seal test is performed first and then the view *Pump size and single-step mode* appears.
9. To confirm the **OK** selection, press **<Enter>**.



10. The system starts up again using the defined parameters.
11. Check whether the pump is filling correctly and, if necessary, adjust the Ikus parameters.
12. Secure the pump end of the driving tube with a cable tie strap. Important: Only the cable ties and cable tie guns provided should be used. See section 9.11: Securing the connections, page 130.

## 14.4 Please check left / right pump and driving tube

- **Please check left pump and driving tube!**
- **Please check right pump and driving tube!**

The Ikus has detected an excessively deviating flow: The mean values of the last 16 cycles and of the last 1024 cycles deviate by more than 10 % from each other. Depending on the components, the parameters and the cause of the message, the message will be displayed usually within 5 s to 1 min.



**WARNING**

Rates < 60 bpm are intended to be used only for implantation and explantation. Never use the Ikus with a rate < 60 bpm without constant supervision.

**IMPORTANT:** First mute the message on the drive unit, do not acknowledge yet in the monitor program. Otherwise, alarms will occur by mistake. When muted, the alarm will be audible again in an 1-minute interval.

### ➤ INSTRUCTION

1. Mute the message on the drive unit.
2. Inspect the driving tube and the cannulae: are kinks blocking the flow? Correct the positions to ensure an unimpaired flow.
3. Inspect the driving tube and the plugs. If a plug is not positioned correctly: re-insert it correctly. If the driving tube is defective: replace it (see section 14.3.1: Replacing a driving tube, page 174).
4. If necessary, adjust the parameters. Wait until the message **Left: Pump output measurement activated** or **Right: Pump output measurement activated** appears.
5. If necessary, correct the position of the cannulae.
6. Assess the hemodynamic status of the patient (volumes, MAP, PAP, CVP, etc.).

**If the message appears again:**

### ➤ INSTRUCTION

1. Mute the message on the drive.
2. Confirm the parameter values. For that the cursor must be in the parameter table.
3. Assess the patient's hemodynamic status (volume, MAP, PAP, CVP...)

4. Monitor the membrane movement and make sure that the pump(s) are filling and ejecting completely. If this is quite correct, confirm the message in the monitor program.
5. If the message appears again, then the parameters can be modified slightly to normalize the flow.
6. Assess the hemodynamic status of the patient (volumes, MAP, PAP, CVP, etc.).
7. Monitor the membrane movement and make sure that the pump(s) are filling and ejecting completely. If this is functioning properly, then acknowledge the message in the monitor program.
8. If the message appears again, check if it is necessary to adjust the cannulae.

If the message appears again:



---

**Notify Berlin Heart! 866.249.0128**

---

## 14.5 Backup operation left/right

- [Backup operation \(right\). Contact customer service](#)
- [Backup operation \(left\). Contact customer service](#)

The left (or right) pneumatic system has failed. The respective pump is now being powered by the backup system.

### ➤ INSTRUCTION

1. Provide the patient immediately with a replacement Ikus.



---

**Notify Berlin Heart! 866.249.0128**

---

## 14.6 Error messages in emergency operating mode

### 14.6.1 UVAD, emergency operation!. Contact service immediately!

[UVAD, emergency operation! Contact service immediately!](#)

Appears in univentricular mode.



---

No more system is available as a redundancy. If the only remaining intact pneumatic system fails, there is a risk that the Ikus will stop running altogether.

---

The blood pump is being driven by the last intact pneumatic system.

The pneumatic system continues running with the currently set parameters. The parameters can still be adjusted if necessary. However, it is not possible to switch over to biventricular operation.

### ➤ INSTRUCTION

1. Provide the patient immediately with a replacement Ikus.



**Notify Berlin Heart! 866.249.0128**

## 14.6.2 Emergency operation system 1 (or system 2 or 3). Contact Service now!

- [Emergency operation System 1. Contact service now!](#)
- [Emergency operation System 2. Contact service now!](#)
- [Emergency operation System 3. Contact service now!](#)



There is no longer a redundant backup system. If the only remaining intact system fails, there is a risk that the Ikus will stop running altogether.

Appears in biventricular mode

Both blood pumps are being driven by the last intact pneumatic system.

The pneumatic system will now operate with fixed parameters (synchronous mode, systolic pressure 250 mmHg, diastolic pressure -100 mmHg, 70 bpm, relative systolic duration 40 %). It is not possible to change these settings.

### Possible causes:

- 2 of the 3 pneumatic systems have developed faults.
- The Ikus driving unit has been running on battery power for too long (Error message: [Emergency operation due to empty batteries: Risk of total failure!](#)). It was no longer possible to establish reliable conditions. In order to ensure that this is not due to a control circuit defect, the Ikus has switched over to the backup system and the backup control computer. The message [Backup computer started! Contact customer service.](#) is displayed.

### INSTRUCTION

1. Provide the patient immediately with a replacement Ikus.



**Notify Berlin Heart! 866.249.0128**

## 14.7 System 1 (or system 2) is defective!

- [System 1 \(left\) is defective!](#)
- [System 2 \(right\) is defective!](#)

The respective pneumatic system has developed a fault. The backup system (system 3) is activated. If this error occurs during backup operation, Ikus will be running in emergency operating mode. In this case, Ikus has no more redundancy.

### INSTRUCTION

1. Provide the patient immediately with a replacement Ikus.



**Notify Berlin Heart! 866.249.0128**

## 14.8 System 3 (backup) is defective!

### System 3 is defective!

The backup pneumatic system is detected as a fault during backup operation.

The Ikus runs in emergency operating mode. Provide the patient immediately with a replacement Ikus.

**➤ INSTRUCTION**

1. Provide the patient immediately with a replacement Ikus.

**📞 HOTLINE** **Notify Berlin Heart! 866.249.0128**

## 14.9 Alarm circuit fault: buzzer remains off (or on)

- **Alarm circuit test failed - buzzer remains off!**
- **Alarm circuit test failed - buzzer remains on!**

**⚠ WARNING** If this is the case, the Ikus will not generate an acoustic signal in an alarm situation, or it will generate a wrong signal. Observe the messages displayed in the message window carefully and look out for the visual alarm signal in the display and operating panel. Do not operate the Ikus without supervision!

A fault in the alarm circuit is discovered during the self-test for the alarm circuit or when an alarm situation occurs. Depending on the type of fault, the message appears:

- **Alarm circuit test failed - buzzer remains off!**
- **Alarm circuit test failed - buzzer remains on!**
- **Acoustic alarm is not properly recognized**

**➤ INSTRUCTION**

1. Provide the patient immediately with a replacement Ikus.

**📞 HOTLINE** **Notify Berlin Heart! 866.249.0128**

## 14.10 Backup computer faulty! Contact customer service.

### Backup computer faulty! Contact customer service.

**NOTICE** Depending on when the fault occurs, the error message **Processor down. Inform service!** may not appear due to unfavorable resynchronization time response. In this case the drive will provide a visual and acoustic signal, however, no error message will be displayed.

One of the processors has failed. If the main computer fails, the message **Backup computer started! Contact customer service.** also appears.

**➤ INSTRUCTION**

1. Provide the patient immediately with a replacement Ikus.



---

**Notify Berlin Heart! 866.249.0128**

---

## 14.11 Backup computer

### 14.11.1... reports discrepancy in left/right pump output measurements!

- [Backup computer: discrepancy in left pump output measurement](#)
- [Backup computer: discrepancy in right pump output measurement](#)

The main computer has detected a flow error. This message only appears in conjunction with the message in section 14.4: Please check left / right pump and driving tube, page 175. Immediately take the measures described there



---

**Notify Berlin Heart! 866.249.0128**

---

### 14.11.2... reports faulty measurements on the left (or right)

- [Backup computer: reports faulty measurement left!](#)
- [Backup computer: reports faulty measurement right!](#)

The main and backup computers show different results.

**If this message appears only once,**  
no further measures are necessary.

**If the message appears again:**

#### **➤ INSTRUCTION**

1. Check the status of the patient.
2. Check the filling and emptying of the blood pump(s), and monitor the function of the Ikus. Do not operate the Ikus without supervision!
3. Provide the patient immediately with a replacement Ikus and switch off the malfunctioning Ikus. (see section 15.4: Connecting the patient to a replacement Ikus, page 202). If no replacement Ikus is available: Support the patient, if necessary (in the event of a malfunction of the defective Ikus), by means of the manual pump! (see section 15.5: Driving blood pump(s) with the manual pump, page 204).



---

**Notify Berlin Heart! 866.249.0128**

---

### 14.11.3... reports an error in output measurement on the left (or right) pump

- [Backup computer reports error: left pump output measurement](#)
- [Backup computer reports error: right pump output measurement](#)

The backup computer has detected a flow error, but the main computer has not.

#### **➤ INSTRUCTION**

1. Check the filling and emptying of the blood pump(s).
2. Check the plausibility of the measured values.

3. Reset all of the parameter values. In addition, log out of the monitor program and then log back into it. Navigate the cursor with <←> / <→> to the desired field, adjust the value with <↓>/<↑>/ <Bild ↓>, <Bild ↑> , then confirm with <Enter>. The system works with the new value..

**If the message appears again:**



**Notify Berlin Heart! 866.249.0128**

### 14.11.4... reports faulty test

#### Backup computer reports faulty test

The main computer cannot end the test phase to check the system after the error message...(See section 14.1: Pressure error / time error in system 1 (or in system 2 or 3), page 173.)

- [Pressure fault in system 1 \(left\), please wait ...](#)
- [Pressure fault in system 2 \(right\), please wait ...](#)
- [Pressure fault in system 3 \(backup\), please wait ...](#)
- [Time error system 1 \(left\), please wait ...](#)
- [Time error system 2 \(right\), please wait ...](#)
- [Time error system 3 \(backup\), please wait ...](#)

IMPORTANT: The blood pump being driven by the tested system stops for approx. 10 seconds during the test phase.

#### ➤ INSTRUCTION

1. Check the status of the patient.
2. If the Ikus switches to backup operating mode or this message repeatedly appears, inform Service immediately.
3. Provide the patient immediately with a replacement Ikus. See section 15.4: Connecting the patient to a replacement Ikus, page 202.



**Notify Berlin Heart! 866.249.0128**

## 14.12 Measurement discrepancy in main computer (backup computer)

- [Measurement discrepancy in main computer!](#)
- [Measurement discrepancy in backup computer!](#)



Between the error message [Measurement discrepancy in main computer!](#) and the 2nd (relevant) error message there can be a delay of several seconds. At any case, wait for both error messages.

Only the active processor has detected an error. This message only appears in conjunction with an additional, relevant error message. Immediately take all of the necessary measures for this second message.

**If the message appears only once at the backup computer,**  
it is only an information message.

**If the message appears several times****➤ INSTRUCTION**

1. Provide the patient immediately with a replacement Ikus.

**☎ HOTLINE****Notify Berlin Heart! 866.249.0128****14.13 Parameter set update failure**

The Ikus cannot store the changed parameter values in the internal system memory. The driving unit is operating with the changed values, but if a reset were to be performed, the old values would be valid again.

**➤ INSTRUCTION**

1. Check the parameter values regularly. After a reset, if the Ikus continues to work with the old parameter values: Re-adjust the parameter values.

**If the message appears again:****➤ INSTRUCTION**

1. Provide the patient immediately with a replacement Ikus.

**☎ HOTLINE****Notify Berlin Heart! 866.249.0128****14.14 Temperature sensors: <<8-digit binary code>>**

- **Temperature sensors: <<8-digit binary code>>**

**⚠ WARNING**

Do not use water or other liquids to cool the Ikus! Otherwise there is a risk of short circuit and/or device malfunction.

**IMPORTANT:** An alarm was triggered by one of the sensors and an user muted it (mute interval: 10 min). During this mute interval now another sensor generates another alarm which is also muted by the user. This means that the remaining mute time of the first triggered alarm will be extended for another full mute interval.

**➤ INSTRUCTION**

1. Determine whether internal or external influences have caused the driving unit to over-heat. Is it exposed to direct heat from external sources? Is the ambient temperature too high?
2. If possible, remedy the situation (move the Ikus away from the heater, etc.). Provide adequate ventilation. Acknowledge the message. The Ikus takes a few minutes to cool down. Acknowledge the message repeatedly if necessary.

Usually, overheating of the Ikus is due to external factors such as direct thermal radiation (e. g. direct sunlight or from heaters). Overheating may also be caused by an internal fault, but this rarely occurs.

**If external influences can be excluded as factors causing the message...**



---

**Notify Berlin Heart! 866.249.0128**

---

IMPORTANT: When passing on the error code to the service department directly (by telephone or fax): remember to state all 8 digits!

If necessary the service department will request to read out the LOG files and send a copy to Berlin Heart, Inc. (see section 15.7: Reading out the LOG files, page 207).

## 14.15 Fault: <<16-digit binary code>> (<<type of fault>>)

- **Fault: <<16-digit binary code>>**
- **<<type of fault>>**



---

**Notify Berlin Heart! 866.249.0128**

---

IMPORTANT: When passing on the error code to the service department directly (by telephone or fax): remember to state all 8 digits!

If necessary the service department will request to read out the LOG files and send a copy to Berlin Heart, Inc. (see section 15.7: Reading out the LOG files, page 207).

## 14.16 Batteries discharged; battery operation not possible

**ABORT: Batteries discharged! No Battery operation possible!**

The batteries have become discharged during mains operation by a battery malfunction.



---

Continue to operate the Ikus on mains! There is a risk of total malfunction if battery operation is used!

---

### **INSTRUCTION**

1. Check the status of the patient.
2. Check the filling and emptying of the blood pump(s), and monitor the function of the Ikus. Do not operate the Ikus without supervision!
3. Provide the patient immediately with a replacement Ikus and switch off the malfunctioning Ikus. (see section 15.4: Connecting the patient to a replacement Ikus, page 202). If no replacement Ikus is available: Support the patient, if necessary (in the event of malfunction of the defective Ikus), by means of the manual pump! (see section 15.5: Driving blood pump(s) with the manual pump, page 204)



---

**Notify Berlin Heart! 866.249.0128**

---

**If this message appears during the start test**

it is only an information message. By all means continue to operate the Ikus on mains! After a sufficient charging time in mains operation the message **Battery charge OK.** appears.



## 14.17 Insufficient battery charge. Only limited battery operation

- **Insufficient battery charge. Only limited battery operation**



Keep Ikus connected to mains! Danger of total shutdown after brief battery operation.

### ➤ INSTRUCTION

1. Check the status of the patient.
2. Check the filling and emptying of the blood pump(s), and monitor the function of the Ikus. Do not operate the Ikus without supervision!
3. Provide the patient immediately with a replacement Ikus and switch off the malfunctioning Ikus. (see section 15.4: Connecting the patient to a replacement Ikus, page 202). If no replacement Ikus is available: Support the patient, if necessary (in the event of malfunction of the defective Ikus), by means of the manual pump! (see section 15.5: Driving blood pump(s) with the manual pump, page 204)



**Notify Berlin Heart! 866.249.0128**

If the batteries reach a sufficient state of charge the message Battery charge OK. appears.

## 14.18 Error messages - Circuit breaker and internal battery fuse

- **DANGER:Battery fuse test failed! - Check circuit breaker! No battery mode possible! Contact service.**
- **DANGER:Internal battery fuse test failed! No battery mode possible! Contact service.**

The following applies to both error messages:



Ikus must be kept connected to the power supply! Danger of total shutdown in battery mode!

### ➤ INSTRUCTION

1. Try to reset the circuit breaker on the connection panel (press button Circuit breaker).
2. If the button Circuit breaker can be pressed, the message Battery fuse test OK. will appear within 10 minutes. After this the error has been eliminated and battery operation is possible again.
3. If the button Circuit breaker cannot be pressed or triggers again, the internal battery fuse has failed. In this case the replacement Ikus must be connected immediately (see section 15.4: Connecting the patient to a replacement Ikus, page 202).

Also see section 15.8: Circuit breaker and battery fuse, page 208.

## 14.19 Electronic malfunction. Contact customer service!

This message appears if the internal power supply of the electronic equipment is faulty.



---

Danger of total malfunction of the Ikus in the event of an additional error! Take immediate action!

---

**➤ INSTRUCTION**

1. Provide the patient immediately with a replacement Ikus and switch off the malfunctioning Ikus. (see section 15.4: Connecting the patient to a replacement Ikus, page 202). If no replacement Ikus is available: Support the patient, if necessary (in the event of malfunction of the defective Ikus), by means of the manual pump! (see section 15.5: Driving blood pump(s) with the manual pump, page 204)



---

**Notify Berlin Heart! 866.249.0128**

---

## 14.20 Acoustic alarm is not properly recognized

**If the message Acoustic alarm: OK appears within 8 seconds after the error message,**

the Ikus is working perfectly. No further measures are necessary.

**If the message Acoustic alarm: OK does not appear within 8 seconds,**

the alarm circuit is defective. A possible error might not have been detected.

**➤ INSTRUCTION**

1. Check the status of the patient.
2. Check the filling and emptying of the blood pump(s), and monitor the function of the Ikus. Do not operate the Ikus without supervision!
3. Provide the patient immediately with a replacement Ikus and switch off the malfunctioning Ikus. (see section 15.4: Connecting the patient to a replacement Ikus, page 202). If no replacement Ikus is available: Support the patient, if necessary (in the event of malfunction of the defective Ikus), by means of the manual pump! (see section 15.5: Driving blood pump(s) with the manual pump, page 204)



---

**Notify Berlin Heart! 866.249.0128**

---

## 14.21 Error: no data/no reaction from the control computer

- **Error: no data from Master.**
- **Error: no reaction from Master.**

In the event of the simultaneous malfunction of both control computers or the malfunction of the power supply, the Ikus cannot generate a specific error message in the message window.

**➤ INSTRUCTION**

1. Check the status of the patient.
2. Evaluate the malfunction scenario:
  - **no alarm, but the Ikus continues to function:** no communication between the control computers and the laptop
  - **optical and acoustic alarm, and the Ikus is working in emergency mode:** both control computers are defective
  - **The Ikus is halted; acoustic alarm only:** Defective power supply
3. Provide the patient immediately with a replacement Ikus and switch off the malfunctioning Ikus. (see section 15.4: Connecting the patient to a replacement Ikus, page 202).  
 If no replacement Ikus is available and the Ikus is running: Check the filling and emptying of the blood pump(s), and monitor the function of the Ikus. Do not operate the Ikus without supervision!  
 If no replacement Ikus is available and the defective Ikus is halted: Support the patient with the manual pump. (see section 15.5: Driving blood pump(s) with the manual pump, page 204).

**HOTLINE****Notify Berlin Heart! 866.249.0128****14.22 Left/right flow sensor defective. Notify Service!**

- **Left flow sensor fault. Contact customer service.**
- **Right flow sensor fault. Contact customer service.**

The corresponding flow sensor is defective. Although the Ikus continues to run, the excessively low flow would not be detected - possibly due to a kink in a cannula or the driving tube.

**WARNING**

Do not operate the Ikus without supervision! Otherwise an insufficient support of the patient might not be detected.

**NOTICE**

In biventricular mode there is a flow alarm for one of the blood pumps. The user stops the pump operation of the other blood pump and restarts it. This affects that during the restart the flow alarm will be deleted, whether its reason continues to exist or not.

**IMPORTANT:** If the defective Ikus is not replaced, this message appears repeatedly at 10-minute intervals.

**➤ INSTRUCTION**

1. Check the status of the patient.
2. Check the filling and emptying of the blood pump(s), and monitor the function of the Ikus. Do not operate the Ikus without supervision!

3. Provide the patient immediately with a replacement Ikus and switch off the malfunctioning Ikus. (see section 15.4: Connecting the patient to a replacement Ikus, page 202). If no replacement Ikus is available: Support the patient, if necessary (in the event of malfunction of the defective Ikus), by means of the manual pump! (see section 15.5: Driving blood pump(s) with the manual pump, page 204)



**Notify Berlin Heart! 866.249.0128**

### 14.23 Problem: <<Text>>

**If this message appears during the start-up test::**

see section 14.25: Error messages during the start-up test, page 187.

**If this message appears outside of the start-up test,**

a serious problem exists.

**The Ikus has detected a serious problem.**

#### **➤ INSTRUCTION**

1. Check the status of the patient.
2. Check the filling and emptying of the blood pump(s), and monitor the function of the Ikus. Do not operate the Ikus without supervision!
3. Provide the patient immediately with a replacement Ikus and switch off the malfunctioning Ikus. (see section 15.4: Connecting the patient to a replacement Ikus, page 202). If no replacement Ikus is available: Support the patient, if necessary (in the event of malfunction of the defective Ikus), by means of the manual pump! (see section 15.5: Driving blood pump(s) with the manual pump, page 204)



**Notify Berlin Heart! 866.249.0128**

### 14.24 Self-test is not completed by passive computer!

The passive processor was unable to end the self-test of the alarm circuit.

**If, within 8 seconds, the message Alarm circuit test OK appears,**

the Ikus is working perfectly. No further measures are necessary.

**If the message Alarm circuit test OK does not appear within 8 seconds,**

the alarm circuit is defective. A possible error might not have been detected.

**The Ikus has detected a serious problem.**

#### **➤ INSTRUCTION**

1. Check the status of the patient.
2. Check the filling and emptying of the blood pump(s), and monitor the function of the Ikus. Do not operate the Ikus without supervision!

3. Provide the patient immediately with a replacement Ikus and switch off the malfunctioning Ikus. (see section 15.4: Connecting the patient to a replacement Ikus, page 202). If no replacement Ikus is available: Support the patient, if necessary (in the event of malfunction of the defective Ikus), by means of the manual pump! (see section 15.5: Driving blood pump(s) with the manual pump, page 204)

**HOTLINE****Notify Berlin Heart! 866.249.0128**

## 14.25 Error messages during the start-up test

In addition to the error messages listed below there are additional messages possible that are described in chapter 12. Always take those measures corresponding to the indicated messages.

The error messages listed here can only occur during the start test. At any case wait for the end of the start test. Afterwards the corresponding measures are to be initiated.

### 14.25.1 Battery test skipped (Battery problem!)

The charge level of the batteries is too low to permit battery operation.

#### ➤ INSTRUCTION

1. Operate the Ikus on mains. Battery operation is only possible if all of the yellow LEDs are illuminated.

### 14.25.2 Additional messages during the start-up test

If the Ikus detects an error during the start-up test, one of the following messages appears in the message window depending on the nature of the error:

- **Problem: batteries have very different charges.**
- **Problem: battery controller: batteries are discharged**
- **Problem: Charge unit fault. Contact customer service.**
- **Problem: Laptop fault. Contact customer service.**
- **Problem: Power relay. Contact customer service.**
- **Problem: Mains sensor fault. Contact customer service.**
- **Problem: Mains voltage. Check power and switch.**
- **Problem: Power pack fault. Contact customer service.**
- **Problem: WR2 fault / relay board**
- **Problem: Relay 1 faulty. Contact customer service**
- **Problem: Relay 2 faulty. Contact customer service**
- **Problem: WR1 not switching. Contact customer service.**
- **Problem: 0000 0011 0011 0111(fault in power supply)** see section 14.15: Fault: <<16-digit binary code>> (<<type of fault>>), page 182.

**Restart the Ikus after the start-up test if one of the above messages appears**

**➤ INSTRUCTION**

1. According to display: If necessary: enter <7> to read any messages; go back by pressing <Enter>. Important: enter <1> or <x> to exit the monitor program. A 2. window appears.
2. 2. window: According to the display, select the option **End**. The monitor program writes a log file and is terminated. Wait until the message **Switch off drive with main switch!** appears.
3. Switch off the main switch (key switch) and then switch it back on again.

**If the Ikus now ends the start-up test without a message:**

Start up the Ikus.

**If one of the above messages appears again:**

**➤ INSTRUCTION**

1. Do not start up the Ikus. Provide the patient immediately with a replacement Ikus.



**HOTLINE**

**Notify Berlin Heart! 866.249.0128**

### 14.26 Discrepancy in pressure measurement: system 1 (or system 2 or 3)

- **Discrepancy in pressure measurement: system 1 (left)**
- **Discrepancy in pressure measurement: system 1 (right)**
- **Discrepancy in pressure measurement: system 1 (backup)**

This message is only an information message.

**➤ INSTRUCTION**

1. Check the status of the patient.
2. Check the filling and emptying of the blood pump(s), and monitor the function of the Ikus. Do not operate the Ikus without supervision!
3. Compare nominal values with the values actually generated. In the event of discrepancies from high set values, if necessary reduce rate accordingly and/or vary relative systolic duration, lower systolic driving pressure (e.g. from 210 mmHg to 200 mmHg), and/or raise the diastolic driving pressure parameters (e.g. from -40 mmHg to -45 mmHg) if appropriate.
4. Scroll down message window to check if message has previously appeared.
5. Continue to observe message window to see if message reappears.

The information message **Discrepancy in pressure measurement: system 1 (2 or 3)** appears when the compressed air being produced at a constant rate by the compressor in the present pump cycle is unable to meet the compression levels required to achieve the defined parameters.

The message can have the following causes:

- Extreme parameter values have been set (extremely high values, extremely low values)
- Restricted pneumatic performance (maintenance required)
- System malfunction

**If the message appears several times within 24 hrs**

**NOTICE**

---

Damage to the Ikus is technically impossible when this message appears!

---

Avoid a further increase in the rate or, alternatively, the driving pressure for parameters set at high values. Otherwise the Ikus might perform a test phase, which means that the blood pump of the corresponding system is briefly stopped for the duration of this test

---

The information message Discrepancy in pressure measurement: system 1 (2 or 3) is not accompanied by an acoustic signal.

---

**HOTLINE**

**Notify Berlin Heart! 866.249.0128**

---

## 14.27 Communication with Laptop failed

This message informs the user that the communication between the control computers and the monitor program has been temporarily interrupted. This occurs if the monitor program is exited, for example to administrate user IDs and passwords. Since this message only appears when the communication is re-established, this message does not require user intervention.

*This page was left blank intentionally*



# 15 Troubleshooting and correcting faults



Notify Berlin Heart! 866.249.0128

Problem	Cause of problem / action to be taken
Deposits in the pump	Initial deposits: check anticoagulation status and adjust therapy if necessary.  If floating deposits are detected (may cause thromboembolic complication): replace the pump, see section 15.1: Replacing the blood pump(s), page 195.
Visible blood pump faults	Replace the pump, see section 15.1: Replacing the blood pump(s), page 195.
<p>Pump membrane remains in the diastolic or systolic position despite vibration / movement of the pump indicating that the Ikus is attempting to provide diastolic or systolic pressure</p> <p>Pump membrane remains in one position despite the above manipulations</p>	<p><b>Possible causes:</b></p> <ul style="list-style-type: none"> <li>• kinking of the cannula</li> <li>• clotting of the pump</li> <li>• partial malfunction of the Ikus</li> </ul> <p><b>What to do?</b></p> <p>Check for external forces on the cannula and whether it may be necessary to manipulate the cannula, see section 14.4: Please check left / right pump and driving tube, page 175.</p> <p>Check for clots in the pump or cannula that may be obstructing flow and replace the pump if necessary, see section 15.1: Replacing the blood pump(s), page 195.</p> <p>Initiate hand-pumping to try to eject the pump, see section 15.5: Driving blood pump(s) with the manual pump, page 204.</p> <p>Switch the patient to the back-up Ikus driving unit, see section 15.4: Connecting the patient to a replacement Ikus, page 202.</p> <p><b>Additional possible causes:</b></p> <ul style="list-style-type: none"> <li>• High vascular resistance</li> <li>• Defective blood pump</li> </ul> <p>There may be air leaking into the space between the first and second layer of the triple-layer pump membrane. This accumulated air may gradually create a “pillowing” effect between the membranes.</p> <p>The top (visible) membrane layer will appear to be continuously in diastole while the bottom two membrane layers are in fact continuously in systole.</p>

Tab. 15-1 Possible problems

<b>Problem</b>	<b>Cause of problem / action to be taken</b>
<p>Blood is seen in front of or in the area around the stabilization ring in the blood pump.</p>	<p>As the lkus continues to provide filling and emptying pressure to the pump, the pump (and possibly the membrane layers) will flex slightly under the changing pressures but will not operate fully.</p> <p><b>What to do?</b></p> <p>If the patient has high vascular resistance, treat medically as appropriate to reduce the resistance. Adjust system parameters to encourage emptying of the pump.</p> <p>If the pump is defective, replace the pump, see section 15.1: Replacing the blood pump(s), page 195.</p>
<p>Condensation in area around the stabilization ring of the blood pump</p>	<p><b>Possible causes:</b></p> <p>Defect of the blood side layer of the triple layer membrane allows blood to leaking into the space between the layers in the area around the stabilization ring.</p> <p><b>What to do?</b></p> <p>Replace the pump, see section 15.1: Replacing the blood pump(s), page 195.</p>
<p>Flapping or fluttering of membrane during membrane movement of the pump</p>	<p><b>Possible cause:</b></p> <p>Partial rupture of one or two layers of the triple-layer membrane. Changes in air pressure during systole and diastole may cause the ruptured layer(s) to flutter.</p> <p><b>What to do?</b></p> <p>Replace the pump, see section 15.1: Replacing the blood pump(s), page 195.</p>
<p>Blood pump membrane rupture during pump priming (prior to patient support)</p>	<p><b>Possible cause:</b></p> <p>If the pump membrane is not moved completely to the diastolic position prior to insertion of the de-airing needle, a puncture of the membrane may occur. When the membrane is in the complete diastolic position, the needle will not puncture the membrane.</p> <p><b>What to do?</b></p> <p>Discard the damaged pump and do not use with the patient. Prime a new pump following the directions in section 8.4: Moving the membrane to the end-of-diastole position, page 112.</p>

Tab. 15-1 Possible problems

Problem	Cause of problem / action to be taken
Cannula rupture	<p><b>Possible cause:</b></p> <p>Damage to cannula caused by excessive external forces or a sharp object.</p> <p><b>What to do?</b></p> <p>Immediately stop the support by disconnecting the driving tube from the Ikus.</p> <p>Clamp the cannula.</p> <p>Follow directions to replace the pump, see section 15.1: Replacing the blood pump(s), page 195.</p> <p>After removing the current pump, trim the cannula proximal to the damaged area.</p>
Defective driving tube(s) found through visible or audible inspection of the tube(s) or from Ikus alarm(s)	<p><b>Possible causes:</b></p> <p>The driving tube has been damaged and the integrity of the tubing may be compromised. There may or may not be an audible sound from air escaping the tubing. This condition may be accompanied by the following error messages.</p> <ul style="list-style-type: none"> <li>• section 14.1: Pressure error / time error in system 1 (or in system 2 or 3), page 173 followed by:</li> <li>• section 14.3: Please connect driving tube, page 174</li> </ul> <p><b>What to do?</b></p> <p>If the driving tube is defective, replace it; see section 14.3.1: Replacing a driving tube, page 174.</p> <p>If a fault in the tubing is not apparent upon inspection, but the Ikus has the above error(s), then follow the directions associated with the error message on the Ikus; see chapter 14: Error Messages and corrective measures, page 171:</p>
Visible Ikus faults	Notify Berlin Heart.

Tab. 15-1 Possible problems

Problem	Cause of problem / action to be taken
<p>Ikus: the graph display stops moving, parameters cannot be adjusted</p>	<p><b>Possible causes</b></p> <ul style="list-style-type: none"> <li>• faulty communications between control computer and laptop</li> <li>• batteries not supplying enough current</li> <li>• the electronics (main and backup control computers) have failed</li> </ul> <p><b>What to do?</b></p> <p>Switch the laptop off and then back on again, wait for the start-up procedure to be completed, then start the monitor program.</p> <p>IMPORTANT: The Ikus continues running with the set parameters.</p> <p><b>The graphs remain frozen</b></p> <p>The Ikus is operating in emergency pulse mode, see section 15.3: Emergency pulse mode, page 200.</p> <p>Notify Berlin Heart.</p> <p>Restart the Ikus after consulting the service department staff: See section 15.2: Restarting Ikus, page 198.</p>
<p>Acoustic and visual alarm from the Ikus, message <b>Error: no data from Master</b> or <b>Error: no reaction from Master</b></p>	<p><b>Possible causes</b></p> <ul style="list-style-type: none"> <li>• simultaneous malfunction of both control computers</li> <li>• power supply malfunction</li> </ul> <p><b>What to do?</b></p> <p>Assess the condition of the patient and the hemodynamic values.</p> <p>Notify Berlin Heart immediately.</p>
<p>Pump stands still - no further pump function; acoustic alarm is still audible</p>	<p><b>Possible causes</b></p> <ul style="list-style-type: none"> <li>• complete failure of the Ikus</li> <li>• batteries are completely empty or serious fault in the batteries</li> </ul> <p><b>What to do?</b></p> <p>Immediately connect the Ikus to the mains. Until that supply the patient with the manual pump. See also section 6.4: Switching between mains and battery operation, page 79 and section 15.5: Driving blood pump(s) with the manual pump, page 204.</p> <p>Notify Hotline immediately.</p>

Tab. 15-1 Possible problems

## 15.1 Replacing the blood pump(s)



When replacing a blood pump, follow the instruction given here. Otherwise the duration of the pump stop will be prolonged and the patient might suffer from inadequate support.

The blood pump may only be replaced under sterile conditions!

All effort should be made to minimize the manipulation and distortion of the blood pumps and cannula during the removal of the cable tie(s) to prevent mobilization of deposits.

The cable tie covering the EXCOR cannula on the stub of the blood pump should be removed carefully. Use an appropriate blunt tool. Important: never use a sharp instrument, for example, a scalpel or scissors, to remove the cable tie. This may cause damage to the cannula.

BVAD: If the left pump is being replaced, the right pump must also be stopped while the pump is being replaced. Otherwise there is the risk of pulmonary edema.

When connecting the blood pump(s), pay attention to the direction of the arrows on the inflow and outflow stubs! These show the direction of the blood flow.

### NOTICE

If the replacement pump has a larger volume than the one being replaced, the use of a connector set must be considered the corresponding parameter in the view *Pump size and single-step mode* must be updated.

**IMPORTANT:** When 2 blood pumps need to be replaced, replace the right blood pump in the first place, subsequently replace the left blood pump.

**IMPORTANT:** Sedate the patient if necessary and administer a bolus of Heparin according to the anticoagulation protocol.

When using a cannula extension set / connecting set: See section 9.3: Cannulae, cannula extension set and connecting set, page 117.

### 15.1.1 Preparing a replacement blood pump

#### Material

- 1 replacement blood pump of appropriate type and size
- 1 driving tube, red or blue
- 1 accessory set (for blood pumps with PU valves) with tube connecting set; **IMPORTANT:** Only the cable ties and cable tie guns provided should be used.

### ➤ INSTRUCTION

1. Bring membrane to the end-of-diastole position, position de-airing needle, rinse and fill pump with sterile injectable saline (see section 8.4: Moving the membrane to the end-of-diastole position, page 112 and section 8.5: De-airing the blood pump, page 112).
2. Connect the driving tube to the respective driving tube connector of the pump.
3. Place the pump, ready for connection, with the titanium connectors pointing upwards.

## 15.1.2 Replacing the right blood pump (RVAD/ BVAD)

### Material

- 1 prepared replacement blood pump (see section 15.1.1: Preparing a replacement blood pump, page 195)
- 1 tube connecting set (cable tie, cable-tie gun), included in the accessory set. Only the cable ties and cable tie guns provided should be used.

### Stopping the right blood pump and detaching the blood pump from Ikus

### ➤ INSTRUCTION

1. Bring the patient into the Trendelenburg position.
2. The cable tie covering the EXCOR cannula on the stub of the blood pump should be removed carefully. Use an appropriate blunt tool.  
Important: never use a sharp instrument, for example, a scalpel or scissors, to remove the cable tie. This may cause damage to the cannula. Check cannulae immediately to make sure they are not damaged.
3. If necessary log into the monitor program by entering user ID and password, confirming the password with **<Enter>**.
4. BVAD: Reduce rate of left blood pump to 30 bpm. Use **<←→/ <→>** to navigate cursor to the respective field of the parameter table, then use **<↓>** to adapt value. Confirm with **<Enter>**.
5. In the monitor program, select the option **Pause left** respectively **Pause right** and press **<Enter>** to confirm. Respond to the prompt in the dialog window by pressing the **<X>** key or the **<1>** key. The right blood pump will stop.  
RVAD: **Pause left**  
BVAD: **Pause right**  
The view *Pump size and single-step mode* is displayed.
6. As soon as the right pump has stopped, clamp off the cannulae beneath the right pump to be replaced and slide the cannulae off the pump. If it is necessary to clamp any other part of the cannula that is not covered with velour, cover the part of the cannula that will be clamped with a gauze sponge.
7. Check cannulae for visible deposits. If necessary, remove these deposits carefully.
8. Remove the driving tube of the pump to be replaced from the connector. To do so, take hold of the release sleeve and pull this out of the connector.

### Connect new right blood pump to the Ikus

#### ➤ INSTRUCTION

1. Fill the free ends of the cannulae with sterile saline solution. Make sure that all air has been removed. Connect the prepared replacement pump to the cannulae.
2. Plug the new driving tube into the freed connector. The plug snaps into place clearly audible.
3. Check that the plug is securely connected. To do so, grip the plug body above the release sleeve and pull on it. Do not pull from the release sleeve, and never from the tube!
4. Release the tube clamps from the cannulae.

### Starting the Ikus

#### ➤ INSTRUCTION

1. Move the cursor to the field **step left** (RVAD) respectively **step right** (BVAD).
2. RVAD: Confirm **Step left** with **<Enter>** to trigger a single step.  
BVAD: Confirm **Step right** with **<Enter>** to trigger a single step.
3. If any air bubbles are visible remove them via the de-airing needle. When all air has been completely removed from the left pump: remove the de-airing needle.
4. Move cursor to the **OK** field and press **<Enter>** to confirm. The driving unit starts up again using the defined parameters.
5. Check whether the pump is filling correctly and, if necessary, adjust the parameters.
6. Secure all connections with cable ties. See section 9.11: Securing the connections, page 130.

### 15.1.3 Replacing the left blood pump (LVAD/ BVAD)



#### WARNING

BVAD: If the left pump is being replaced, the right pump must also be stopped while the pump is being replaced. Otherwise there is the risk of pulmonary edema.

#### Material

- 1 prepared replacement blood pump (see section 15.1.1: Preparing a replacement blood pump, page 195)
- 1 tube connecting set (cable tie, cable-tie gun), included in the accessory set. Only the cable ties and cable tie guns provided should be used.

### Stopping the left blood pump and detaching the blood pump from Ikus

#### ➤ INSTRUCTION

1. Bring the patient into the Trendelenburg position.
2. The cable tie covering the EXCOR cannula on the stub of the blood pump should be removed carefully. Use an appropriate blunt tool. Important: never use a sharp instrument, for example, a scalpel or scissors, to remove the cable tie. This may cause damage to the cannula. Check cannulae immediately to make sure they are not damaged.

3. If necessary log into the monitor program by entering user ID and password, confirming the password with **<Enter>**.
4. In the monitor program, select the option **Pause left** respectively **Drive pause** and press **<Enter>** to confirm. Respond to the prompt in the dialog window by pressing the **<X>** key or the **<1>** key. The right blood pump will stop.  
LVAD: **Pause left** The view *Pump size and single-step mode* is displayed.  
BVAD: **Drive pause** The view *Select operating mode* is displayed.
5. As soon as the pump(s) has/have stopped, clamp off the cannulae beneath the pump to be replaced and slide the cannulae off the pump. If it is necessary to clamp any other part of the cannula that is not covered with velour, cover the part of the cannula that will be clamped with a gauze sponge.
6. Check cannulae for visible deposits. If necessary, remove these deposits carefully.
7. Remove the driving tube of the left pump to be replaced from the connector. To do so, take hold of the release sleeve and pull this out of the connector.

### Connect new left blood pump to the Ikus

#### ➤ INSTRUCTION

1. Fill the free ends of the cannulae with sterile saline solution. Make sure that all air has been removed. Connect the prepared replacement pump to the cannulae.
2. Plug the new driving tube into the freed connector. The plug snaps into place clearly audible.
3. Check that the plug is securely connected. To do so, grip the plug body above the release sleeve and pull on it. Do not pull from the release sleeve, and never from the tube!
4. Release the tube clamps from the cannulae.

### Starting the Ikus

#### ➤ INSTRUCTION

1. Move the cursor to the field **step left**.
2. Confirm **Step left** with **<Enter>** to trigger a single step.
3. If any air bubbles are visible remove them via the de-airing needle. When all air has been completely removed from the left pump: remove the de-airing needle.
4. Move cursor to the **OK** field and press **<Enter>** to confirm. The driving unit starts up again using the defined parameters.
5. Check whether the pump is filling correctly and, if necessary, adjust the parameters.
6. Secure all connections with cable ties. See section 9.11: Securing the connections, page 130.

## 15.2 Restarting Ikus



Do not switch off and restart the *Ikus* unless the service consultant requests to do so (e. g. in emergency operating mode).



---

The Ikus power **switch (toggle switch)** should always be in the **[I]** position, even if the main switch (key switch) is in the **[O]** position!. Otherwise there is a risk that the drive may fail in future due to the Ikus batteries being totally discharged.

---



---

If the graphs in the monitor program are frozen (not moving) and the parameters cannot be adjusted even after the laptop and the monitor program have been restarted, then the Ikus is operating in emergency pulse mode. In this case, do not proceed as described here, but as described in section 15.3: Emergency pulse mode, page 200 instead.

---

#### ➤ INSTRUCTION

1. Support patient with a replacement *Ikus* (see section 15.4: Connecting the patient to a replacement Ikus, page 202) or manual pump (see section 15.5: Driving blood pump(s) with the manual pump, page 204).
2. Use the seal plugs to seal the driving tube connectors.
3. Switch off the *Ikus* driving unit. In the monitor program, select the **Drive OFF** option and press **<Enter>** to confirm. Respond to the prompt in the dialog window by pressing the **<X>** or the **<1>** key. **IMPORTANT:** If it is not possible to select the **Drive OFF** option, the Ikus is running in emergency pulse mode. In this case, proceed as explained in section 15.3: Emergency pulse mode, page 200.
4. Wait until the log has been completed. If the message **Switch off drive with main switch!** appears, turn the key switch to the **[O]** position.
5. Switch off the laptop.
6. Switch Ikus on again immediately. To do so, turn the key switch to the **[I]** position.
7. Switch the laptop on. Select the **1. Start program** option (**<1>**). Enter user ID and password, confirming the password with **<Enter>**.
8. Check all parameters and re-adjust them if necessary.
9. For univentricular operation, unplug the connector marked in red, for biventricular operation, unplug both connectors. To do so, pull the seal plug(s) out of the respective connector(s).
10. Disconnect the driving tube(s) from the replacement *Ikus* or the manual pump and connect it to the Ikus. **IMPORTANT:** Observe the colored markings. The sound of the plug snapping into place is clearly audible.
11. Check that the plug is securely connected. To do so, grip the plug body above the release sleeve and pull on it. Do not pull from the release sleeve, and never from the tube!
12. Move cursor to the **OK** field and press **<Enter>** to confirm. The standard view is shown. The system will operate with the current parameter settings.
13. Switch off the replacement *Ikus* driving unit (see section 6.3.3: Drive OFF: switching the Ikus off, page 78).

### 15.3 Emergency pulse mode



If the *Ikus* is operating in emergency pulse mode, the user must immediately visually check the blood pump(s) to determine whether the pump(s) are filling and ejecting completely. If one pump is not filling and/or ejecting completely the patient must be supported immediately with the replacement *Ikus*. Use the manual pump while securing the replacement *Ikus* (see section 15.4: Connecting the patient to a replacement *Ikus*, page 202 and section 15.5: Driving blood pump(s) with the manual pump, page 204). Otherwise there is the risk that the patient will not be supported sufficiently.

If the emergency pulse mode is activated while the backup system is already active, the *Ikus* is no longer able to drive both pumps. In this case the patient must be supported immediately with the replacement *Ikus*. Use the manual pump while securing the replacement *Ikus* (see section 15.4: Connecting the patient to a replacement *Ikus*, page 202 and section 15.5: Driving blood pump(s) with the manual pump, page 204). Otherwise there is the risk that the patient will not be supported sufficiently.

**IMPORTANT:** In emergency pulse mode a controlled shut down is not possible.

**IMPORTANT:** In emergency pulse mode it is not possible to acknowledge the acoustic alarm.

If the graphs in the monitor program are not moving and the parameters cannot be adjusted even after the laptop and the monitor program have been restarted, then the *Ikus* is operating in emergency pulse mode. Both control computers have failed and are no longer communicating with each other. The emergency pulse board has taken over control of the left and the right pneumatic system.

Replace the *Ikus* with a backup *Ikus* if possible. If no replacement *Ikus* is available, the *Ikus* will continue to support the patient in emergency pulse mode until a replacement *Ikus* is ready.

In emergency pulse mode the system operates with the following settings:

#### Synchronous mode (biventricular)

	Systol. pressure [mmHg]	Diastol. pressure [mmHg]	Rate [bpm]	relat. systole duration [%]
left	210	-40	70	40
right	150	-40	70	40

Tab. 15-2 Settings in emergency pulse mode

**Always immediately ...**



**Notify Berlin Heart! 866.249.0128**

### 15.3.1 Emergency pulse mode - switching the *Ikus* off



Only proceed as described below if a replacement *Ikus* is available to assume the support of the patient as described here.

The *Ikus* power switch (toggle switch) should always be in the [I] position, even if the main switch (key switch) is in the [O] position!. Otherwise there is a risk that the drive may fail in future due to the *Ikus* batteries being totally discharged.

#### ➤ INSTRUCTION

1. Support the patient by a replacement *Ikus* (see section 15.4: Connecting the patient to a replacement *Ikus*, page 202).
2. Use the seal plugs to seal the driving tube connectors on the *Ikus*.
3. Switch off the laptop.
4. Switch off the *Ikus*. To do so, turn the key switch to [O] position.

### 15.3.2 *Ikus* start-test following emergency pulse mode



Do not reconnect the original *Ikus* to the patient until the Berlin Heart, Inc. service department has evaluated the LOG files or has serviced the driving unit.

Wait for at least 5 minutes after switching the *Ikus* off while in emergency pulse mode. Otherwise, only the service staff will be able to restart it.

Never connect other USB devices (e.g. wireless technology) to the USB port of the laptop than the delivered USB sticks.

#### ➤ INSTRUCTION

1. **After 5 minutes:** Insert the USB stick into the USB port and switch on the *Ikus*. To do so, turn the key switch to the [I] position. The battery charge indicator will light up and the number of hours the driving unit has been operated to date will be displayed. The mains operation indicator lights up.
2. Switch the laptop on. The menu *Select language* appears.
3. Select the desired language by pressing the corresponding number key. It is not necessary to press <Enter> to confirm this selection. The start menu is displayed on the laptop.
4. Select the **1. Start program** option (<1>). Enter user ID and password, confirming the password with <Enter>. The *Ikus* will carry out a start-test.
5. Wait for the start-test phase to finish (this takes a few minutes). Do not mute the acoustic signal. The messages in the message window inform the user of the current status of the test. If the system is found to be operating correctly, the view *Select operating mode* will be displayed next.
6. Select **Drive OFF**, then press <Enter> to confirm.

7. Respond to the prompt in the dialog window by pressing the <X> key or the <1> key. The system stops operation immediately and writes an operating log.
8. Wait until the log has been completed (message: **Switch off drive with main switch!**). IMPORTANT: Do not switch the *Ikus* off yet.
9. Shut down the monitor program. Press <F10> and confirm by pressing the <X> key or the <1> key. The start menu is displayed on the laptop.
10. Insert the USB stick in the laptop before the laptop is switched on. In the start menu, select **4. Save data (<4>)**. The LOG files are copied onto the USB stick. After that the start menu appears again.
11. Switch off laptop. Take the USB stick out of the port (but never when the laptop is switched on).
12. Send the LOG files by e-mail to [service@berlinheart.com](mailto:service@berlinheart.com).

## 15.4 Connecting the patient to a replacement *Ikus*



---

The *Ikus* must always be connected to the power supply when it is switched on. This is the only way to ensure that the start-up test is performed completely and possible malfunctions can be detected.

---

This is necessary if ...

- maintenance is required
- the *Ikus* is defective

*Ikus* and all of its parts shall not be serviced or maintained while in use with a patient.

### Switching the replacement *Ikus* on

#### ➤ INSTRUCTION

1. Prepare the replacement *Ikus* and connect it to the mains. Secure the mains cable with the plug clip. Ensure that the power switch (toggle switch) is set to *[I]* position.
2. Use the seal plugs to seal both driving tube connectors.
3. Switch on the replacement *Ikus*. To do so, turn the key switch to the *[I]* position. The battery charge indicator will light up and the number of hours the driving unit has been operated to date will be displayed. The mains operation indicator lights up.
4. Switch the laptop on. The menu *Select language* appears.

### Setting the parameter values of the replacement *Ikus*

#### NOTICE

---

If no parameter values are entered into the replacement *Ikus*, the replacement *Ikus* starts up with the following default parameter values (standard parameters):

---

Systole [mmHg] left/ right	Diastole [mmHg] left/ right	Rate [bpm]	Rel. diast. duration [%] left/ right	Operation mode
210/ 130	-40/ -20	80	40/40	biventricular, synchronous and separate

Tab. 15-3 Default standard parameters

### ➤ INSTRUCTION

1. Select the desired language by pressing the corresponding number key. It is not necessary to press **<Enter>** to confirm this selection. The start menu is displayed on the laptop.
2. Select the **1. Start program** option (**<1>**). Enter user ID and password, confirming the password with **<Enter>**. The *Ikus* will carry out a start-test.
3. Wait for the start-test phase to finish (this takes a few minutes). Do not mute the acoustic signal. The messages in the message window inform the user of the current status of the test. If the driving unit is found to be operating correctly, the view *Select operating mode* will be displayed next.
4. Select **Univentricular (UVAD)** or **Biventricular (BVAD)**, then confirm the selected operating mode with **<Enter>**.
5. In **biventricular** mode, the view *Pump size and single-step mode* is shown. In **univentricular** mode, a connector seal test is first performed (taking approx. 10 seconds). The *Ikus* checks whether the driving tube connector with the blue marking has been sealed. Then the view *Pump size and single-step mode* is displayed.
6. Transfer all the parameters from the original *Ikus* to the replacement *Ikus*.
7. Move cursor to the field **Step left** and press **<Enter>** to confirm.  
**Biventricular:** Move cursor to the field **Step right** and press **<Enter>** to confirm.
8. Move the cursor to the **OK** field. Important: Do not confirm **OK** yet.

The default settings for systole, diastole and relative systole duration depend on whether the pump is registered as the left or right pump in the monitor program.

**Univentricular:** Default setting as for left pump.

### Connecting the blood pump(s) to the replacement *Ikus*

#### ➤ INSTRUCTION

1. For **univentricular operation**, unplug the connector marked in red, for **biventricular operation**, unplug both connectors. To do so, remove the seal plugs from the respective connector(s).
2. **If possible**, log into the monitor program of the original *Ikus*. Select **Drive OFF**, then press **<Enter>** to confirm. Respond to the prompt in the dialog window by pressing the **<X>** key or the **<1>** key. The system stops immediately. If it is not possible to select the **Drive OFF** option, proceed with triggering single steps (**Step left/ Step right**, see instructions in section 15.1: Replacing the blood pump(s), page 195) without stopping the *Ikus*.

3. As soon as the original *Ikus* has stopped, remove the driving tube(s) from it. To do so, take hold of the release sleeve and pull this out of the connector(s).
4. Connect the driving tube(s) to the replacement *Ikus*.  
IMPORTANT: Observe the colored markings. The sound of the plug snapping into place is clearly audible. Check that the plug is securely connected. To do so, grip the plug body above the release sleeve and pull on it. Do not pull from the release sleeve, and never from the tube!
5. To confirm the **OK** selection, press **<Enter>**. The replacement *Ikus* will start up using the defined parameter settings.
6. Check whether the pump is filling correctly and, if necessary, adjust the parameters.
7. Switch off the original *Ikus* (see section 6.3.3: Drive OFF: switching the *Ikus* off, page 78).

## 15.5 Driving blood pump(s) with the manual pump



Fig. 15-1 Patient on manual pump

### This is necessary if ...

- the power supply to the *Ikus* cannot be ensured
- the *Ikus* has to be restarted (e.g. emergency operating mode) and there is no replacement *Ikus* available



---

The use of the manual pump is only permitted for medical personnel trained in the use of it.

---

---

Pay attention to the colored markings on the driving tubes and on the connectors of the manual pump. Otherwise, there is a risk of lung edema.

---

---

Always keep manual pump attached to the *Ikus*. Otherwise in an emergency situation the adequate support of the patient is not guaranteed.

---

---

Call one or more persons to assist. Otherwise in an emergency situation the adequate support of the patient is not guaranteed.

---

The driving tubes and cannulae should be arranged in a bend-free position. Otherwise in an emergency situation the adequate support of the patient is not guaranteed.

---

When operating the manual pump with 1 hand, do not block the valves with your feet (see valve "2" in Fig. 15-2, page 205).

---

**NOTICE**

Seal the connector(s) on the Ikus immediately after removing the driving tube(s) in order to avoid contaminates from entering the system.

---

**IMPORTANT:** In biventricular mode: the blood pumps are driven asynchronously by the manual pump.

**➤ INSTRUCTION**

1. The patient is lying down.
2. Disconnect the driving tube(s) from the Ikus. To do so, take hold of the release sleeve and pull this out of the connector.
3. Connect the driving tube(s) to the manual pump. **IMPORTANT:** Observe the colored markings.
4. Check that the plug is securely connected. To do so, grip the plug body above the release sleeve and pull on it. (see „4“ in Fig. 15-3, page 206) Do not pull from the release sleeve, and never from the tube!
5. Pump steadily and rhythmically at roughly 60 to 80 strokes per minute. **Important:** Move the piston so far that the membrane reaches its final position. The piston need not necessarily be moved to its end position.
6. Perform a visual check of the blood pump to verify that the membrane is moving and that blood is being pumped.

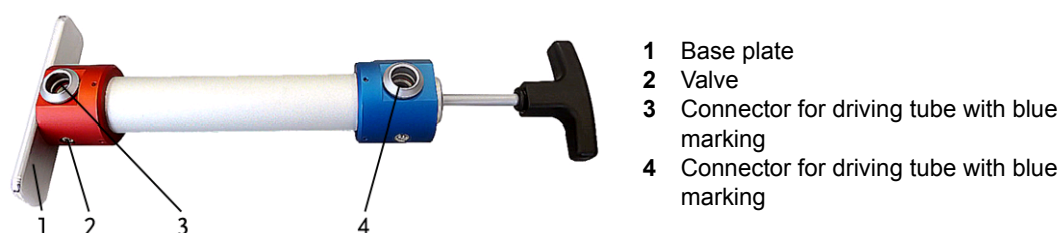

**Fig. 15-2** Manual pump

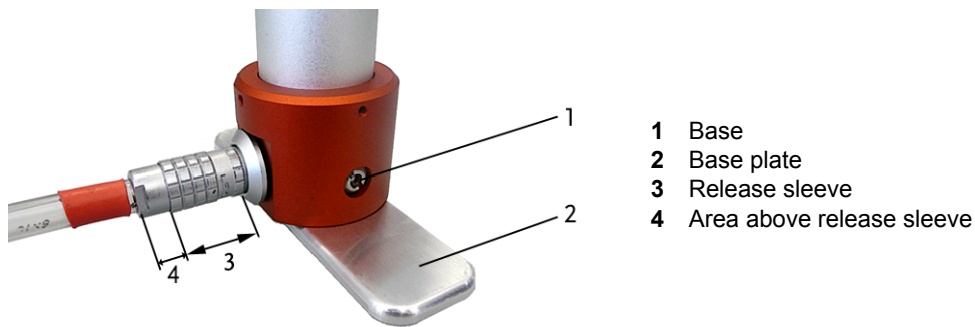

Fig. 15-3 Plug on the driving tube



Fig. 15-4 Examples to operate the manual pump

The manual pump can be operated with both hands or with one hand (placing the pump between the feet). Alternating between two-handed or one-handed pumping, as well as using the left or right hand, is allowed. When doing so, care of the patient must remain ensured.

## 15.6 Mains failure or breakdown of both control computers

### ➤ INSTRUCTION

1. Assess the condition of the patient.
2. Check the filling and ejection behavior of the blood pump(s).
3. If possible: ensure support of patient with a replacement Ikus and switch off the faulty Ikus (see section 15.4: Connecting the patient to a replacement Ikus, page 202).

If both control computers fail at the same time or if there is a mains failure, the Ikus cannot generate any specific error messages in the message window. An acoustic alarm sounds and the indicator lamp on the handle lights up. Depending on the type of fault, the message **Error: no data from Master.** or **Error: no reaction from Master** appears in the message window.

Ikus is running in emergency pulse mode (see section 15.3: Emergency pulse mode, page 200).



**Notify Berlin Heart! 866.249.0128**



## 15.7 Reading out the LOG files

This is necessary if it is not possible to clearly identify function faults even after consultation with the service department.

### **WARNING**

If the user exits the monitor program, it is not possible to identify any incoming messages. For this reason, always start the monitor program again immediately after saving the data.

Use the USB stick provided with the device to save the data. Do not connect any other USB device to the laptop (e.g. wireless technology).

Make sure that you always have the USB stick inserted and that there is sufficient capacity on the stick. Otherwise the LOG files might get lost as they are deleted from the hard disk as soon as they have been transferred onto a USB stick.

### **INSTRUCTION**

1. Press **<F10>** to exit the monitor program and confirm the intention in the dialog window by pressing the **<X>** key or the **<1>** key. The start menu is displayed. The Ikus will continue to operate using the current parameter settings.
2. Switch off the laptop. Insert the USB stick into the port (never do this while the laptop is switched on:). Switch on the laptop again.
3. Select the **4. Save data** option in the start menu. The LOG files are saved onto the USB stick. After completion the start menu appears.
4. Switch off the laptop and remove the USB stick (never do this while the laptop is still switched on!)
5. Switch the laptop on again. To return to the monitor program select the **1. Start program** option in the start menu.
6. Enter user ID and password, confirming the password with **<Enter>**.
7. Send the LOG files by e-mail to [service@berlinheart.com](mailto:service@berlinheart.com).



Fig. 15-5 Laptop CF30 with inserted USB stick



**Fig. 15-6** Left: USB stick with extended plug (operating position); Right: USB- stick with retracted plug (position to transport and store the stick)

## 15.8 Circuit breaker and battery fuse

The Ikus battery pack is protected against excessive current.

There is an internal battery fuse that protects against excessive load current. From outside it is unamenable and after triggering it has to be replaced by the service team.

A second fuse (the circuit breaker) protects against excessive charging current. The circuit breaker is located on the connection panel and it is resettable after one-time triggering (button Circuit breaker flips out) by the operator.

### Activated circuit breaker or internal battery fuse in mains operation



Never disconnect the Ikus from the mains when the circuit breaker or the internal battery fuse are activated. This will cause the driving unit to stop immediately.

#### INSTRUCTION

1. Ensure that the Ikus is connected to the mains.
2. Check if the circuit breaker was triggered. Push the button Circuit breaker back in place to produce power supply again. Important: Only press the button briefly. Never keep the button pressed for a longer period, because otherwise the retriggering of the circuit breaker would not be detected.
3. If the circuit breaker is reactivated, do not press the button in again. Never keep the button pressed for a longer period of time. If possible, support the patient with a replacement Ikus (see section 15.4: Connecting the patient to a replacement Ikus, page 202).



**Notify Berlin Heart! 866.249.0128**

### Activated circuit breaker or internal battery fuse in battery operation mode



The Ikus stops immediately. The blood pumps are no longer being driven.

Whenever the Ikus is running in battery operation, the patient must always be accompanied by a person trained to use the manual pump.



If the circuit breaker or internal battery fuse is activated in battery operation, the Ikus generates an acoustic alarm.

**➤ INSTRUCTION**

1. Check if the resettable circuit breaker was triggered.  
If yes: immediately push it back in place. Start the Ikus again just in case that it does not happen automatically.
2. If the circuit breaker is triggered again, immediately ensure the support of the patient with the manual pump.



---

**Notify Berlin Heart! 866.249.0128**

---

*This page was left blank intentionally*

## 16 Appendix

### 16.1 Overview: Product range and possible combinations

#### 16.1.1 Blood pumps

Article number	Volume [ml]	∅ Inflow / outflow [mm]
P10P-001	10	6
P15P-001	15	9
P25P-001x01	25	9
P30P-001x01	30	9
P50P-001	50	12
P60P-001	60	12

Tab. 16-1 Blood pumps PU valves

#### 16.1.2 Overview: Relationship: body weight – pump size

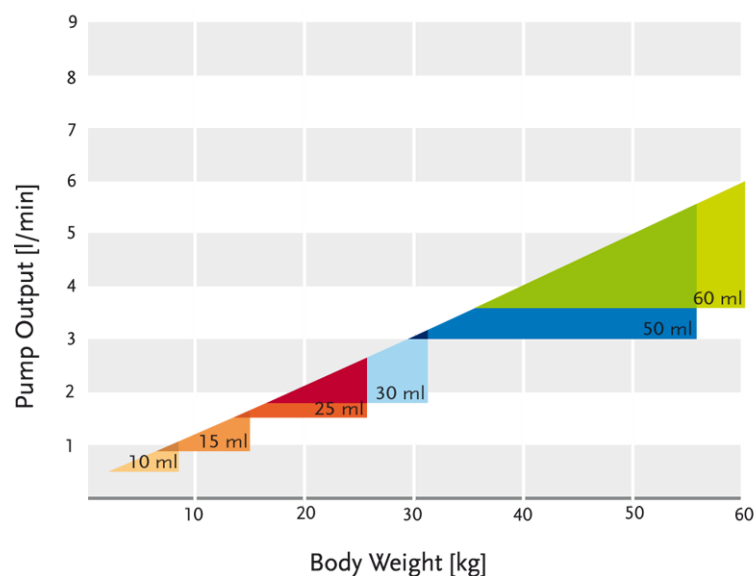

Fig. 16-1 Relationship: body weight - pump size

The final decision of pump selection should be made by the implanting physician based on the individual patients needs and the weight/pump output guidance represented in this graph. Note that the graph represents common clinical use and not the maximum technical performance of the blood pumps.

### 16.1.3 LV apex cannulae

Article number	∅ Lumen [mm]	Overall length [mm]	Length of head [mm]	Angle of head [°]
C14A-040	5	220	14	0
C18A-020	6	250	18	0
C22A-004	12/9 <sup>1</sup>	270/220 <sup>1</sup>	28	0
C27A-001	12	265	38	0
<sup>1</sup> with/ without stage cut off				

Tab. 16-2 LV apex cannulae

### 16.1.4 Atrial cannulae

Article number	∅ Lumen [mm]	Length of corpus [mm]	Length of head [mm]	Angle of head [°]
C15V-040	5	200	15	80
C19V-020	6	250	19	80
C22V-004	9/12 <sup>1</sup>	280/240	22	45
C25V-004	9/12 <sup>1</sup>	280/240	25	45
C22V-002	12	330	22	45
C26V-002	12	330	26	45
<sup>1</sup> with/ without stage cut off				

Tab. 16-3 Atrial cannulae

### 16.1.5 Arterial cannulae

Article number	∅ [mm]	Overall length [mm]	Length of head [mm]	Angle of head [°]	Remarks
C80G-040	5	200	4,5	80	
C80G-021	6	250	5	80	
C60G-004	12/9 <sup>1</sup>	280/240 <sup>1</sup>	0	60	with flexible reinforcement
C85G-004	12/9 <sup>1</sup>	280/240 <sup>1</sup>	0	85	with flexible reinforcement

Tab. 16-4 Arterial cannulae

Article number	∅ [mm]	Overall length [mm]	Length of head [mm]	Angle of head [°]	Remarks
C60G-002	12	330	0	60	with flexible reinforcement
C85G-002	12	330	0	85	with flexible reinforcement
<sup>1</sup> with/ without stage cut off					

**Tab. 16-4** Arterial cannulae

### 16.1.6 Overview: Which cannulae should be used for which pump?

Which pump?	Pump connector Ø [mm]	Cannula lumen Ø [mm] where cannula joins pump	Which inflow cannula?	Which outflow cannula?
P10-001	6	5 5 6 6	C15V-040 (AT) C14A-040 (AP) C19V-020 (AT) C18A-020 (AP)	C80G-040  C80G-021
P15P-001	9	6 6 9 9 9	C19V-020 (AT;CS) C18A-020 (AP;CS) C22V-004 (AT;SC) C25V-004 (AT;SC) C22A-004 (AP;SC)	C80G-021 (CS)  C60G-004 C85G-004
P25P-001x01 P30P-001x01	9	6 6 9 9 9	C19V-020 (AT;CS) C18A-020 (AP;CS) C22V-004 (AT;SC) C25V-004 (AT;SC) C22A-004 (AP;SC)	C80G-021 (CS)  C60G-004 C85G-004 (SC)
P50P-001 P60P-001	12	12 12 12 12 12 12	C22V-004 (AT;SO) C25V-004 (AT;SO) C22V-002 (AT) C26V-002 (AT) C22A-004 (AP; SO) C27A-001 (AP)	C60G-004 (SO;CS) C85G-004 (SO;CS) C60G-002 C85G-002
Explanation:	AT: atrial cannula AP: apex cannula SO: staged (stepped diameter) cannula, original diameter SC: staged (stepped diameter) cannula, diameter after cutting to size CS: connecting set required (A06-009 or A09-012 accordingly)			

**Tab. 16-5** Which cannula for which pump?



### 16.1.7 System accessories

Article number	Designation
T00L-001	Accessory set for blood pumps with PU valves (membrane set, de-airing set and tube connecting set) accessory set: for blood pumps with PU valves
L20H-002	Driving tube, red; length: 200 cm
L20H-003	Driving tube, blue; length: 200 cm

Tab. 16-6 System Accessories

### 16.1.8 Driving unit

Article number	Designation
D03I-111	EXCOR® Stationary Driving Unit Ikus (115V/ 60Hz) - SW 3.41

Tab. 16-7 Driving unit

### 16.1.9 Special components

Article number	Designation
A06-006	Cannula extension set, Ø 6/6 mm
A09-009	Cannula extension set, Ø 9/9 mm
A12-012	Cannula extension set, Ø 12/12 mm
A06-009	Connecting set for cannulae, Ø 6/9 mm
A09-012	Connecting set for cannulae, Ø 9/12 mm

Tab. 16-8 Connecting set and cannula extension set

### 16.1.10 Maximum rates for the pump-cannula combinations

Cannulation		Blood pumps					
Ø inflow cannula	Ø outflow cannula	10 ml	15 ml	25 ml	30 ml	50 ml	60 ml
5 mm	5 mm	130 bpm					
6 mm	5 mm	130 bpm	130 bpm				
6 mm	6 mm	130 bpm	130 bpm	80 bpm	65 bpm		
9 mm	6 mm		130 bpm	100 bpm	90 bpm		
9 mm	9 mm		130 bpm	130 bpm	130 bpm	130 bpm	105 bpm
12 mm	9 mm					130 bpm	105 bpm
12 mm	12 mm					130 bpm	125 bpm

Tab. 16-9 Maximum rates for the pump-cannula combinations



Pump-cannula combinations in which not every parameter combination is recommended (pump rate, % systole, systolic and diastolic pressure) can lead to incomplete filling and emptying of the blood pump.

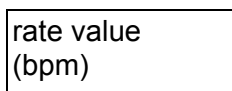

rate value (bpm)

The value indicated is the upper threshold for pump rates. Values that are below the upper threshold are within the acceptable range. Values that are higher than the upper threshold are in a questionable range.

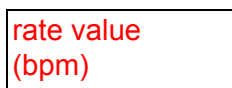

rate value (bpm)

The threshold values have been determined (in vitro) taking a mean arterial blood pressure of 120 mmHg as a basis.

Red marked values displayed on the laptop: These parameter combination (pump rate, % systole, systolic and diastolic pressure) for these pump-cannula combination can lead to incomplete filling and emptying of the blood pump(s). Observe the filling behavior of the blood pump(s)!

in biventricular mode

The lower value of both pump rates (corresponding to the pump sizes used) must also be considered. The higher of the 2 pump rates should be disregarded.

When using staged cannulae or a cannula extension set / connecting set, the pumping rate may not be greater than the respective value found, as the pump will not eject its full volume at higher rates.

### 16.1.11 Blood pump combinations in biventricular mode

left blood pump	right blood pump
10 ml	10 ml
15 ml	15 ml
30 ml	25 ml
60 ml	50 ml

Tab. 16-10 Recommended combinations

Check whether a blood pump combination that is not recommended has been selected for the patient. The final decision on the combination of blood pumps and cannulae is to be reached by the implanting surgeon, in consultation with Berlin Heart, Inc Clinical Affairs.

### 16.1.12 Relative systolic duration

The relative systolic duration is adjustable in the range of 20% and 70%. The upper and lower threshold (20-30% and 60-70%) are marked in red on the laptop. For these values it cannot be guaranteed that the activated pressure parameters are achievable for each single case.

## 16.2 Technical specifications

<b>Electro-pneumatic extracorporeal ventricular assist device EXCOR® Pediatric VAD with Stationary Driving Unit Ikus</b>	
Manufactured by:	Berlin Heart GmbH Wiesenweg 10 2247 Berlin Germany
Classification	Class 3
<b>Overall system (except sterile products)</b>	
Ambient temperature in operation	+10 °C to +30 °C; with restrictions of the battery performance up to +35°C
Ambient temperature, transportation and storage	-10 °C to +50 °C ; 6 h warming-up period before commissioning after transportation

Tab. 16-11 Technical specifications

<b>Electro-pneumatic extracorporeal ventricular assist device EXCOR® Pediatric VAD with Stationary Driving Unit Ikus</b>	
Max. permitted ambient magnetic field strength	10 A/m
Relative humidity of environment	45 to 75 %
Ambient atmospheric pressure	max. 2000 m (6562 ft) above MSL (mean sea level)
<b>Pump</b>	
Dimensions	Refer to product data sheets
Material	Casing and membranes: polyurethane Driving tube adapter: polyoxymethylene Connectors: titanium
Coating of blood contact surfaces	Carmeda® BioActive Surface (CBAS®)
Max. period of use	max. 1 year
<b>Cannulae</b>	
Dimensions	Refer to product data sheets
Material	Silicone, partially reinforced with plastic webbing, partially encased with suture-suitable polyester velour; some equipped with flexible metal reinforcement: wire 2 mm, circular steel Rd 1.4301; apex cannula with a titanium alloy shell
<b>For all sterile products</b>	
Long-term storage conditions	Temperature: +15°C to 25°C Relative humidity: 35 % to 50 % Store in a dry place!
<b>Ikus</b>	
Dimensions (W x H x D)	46 x 95 x 73 cm with laptop cover down (approx. 18.5 x 37.5 x 29 inches) 46 x 120 x 73 cm with laptop cover open (approx. 18.5 x 47.5 x 29 inches)
Weight	100.6 kg (approx. 219 lb)

Tab. 16-11 Technical specifications

<b>Electro-pneumatic extracorporeal ventricular assist device EXCOR<sup>®</sup> Pediatric VAD with Stationary Driving Unit Ikus</b>	
Input voltage	AC 115 V
Frequency	60 Hz
Power drawn	575 VA
Mains fuse	5 A
Mains cable	10 A, hospital grade
Connector External alarm	electrical data: max 1 A, 24 V insulation specifications: 2.5 mm/ 4 mm clearance and creepage distance between alarm contact and 24 V extra low voltage inside the device (coil-sided) insulation test voltage: 500 V
Protection class	IPX1 (protection against touching live parts not tested, tested safety from vertically dripping water)
Pump rate	30 to 150 bpm
Sound level of acoustic alarm	71 dB (A)
Systolic pressure:	60 to 350 mmHg
Diastolic pressure	-100 to 0 mmHg
Pressure display accuracy	±10%
Relative systolic duration	20 % to 70%
Off-mains operating time	max. 30 minutes
Battery charging time	6 h
Maintenance interval	2000 operating hours (at the latest after 6 months). In the event of permanently higher ambient temperatures than recommended, the maintenance intervals can shorten drastically.
Product life Ikus	max. 8 years

Tab. 16-11 Technical specifications

### 16.3 Symbols and tags























	Refer to instruction booklet / manual		Example of symbol for NumLk and Caps Lock status LED on laptop
	Caution		Type B applied part
	General warning sign		Type CF applied part
	Catalogue number		MR unsafe (Magnetic Resonance Imaging unsafe)
	Batch code		Keep dry
	Serial number		WEEE symbol: not to be disposed of with consumer waste
	Manufacturer		Can be disposed of with consumer waste
	Date of manufacture		Use-by date
	Sterilized using ethylene oxide		Do not use if package is damaged
	Do not re-use		Do not re-sterilize
	Humidity limitation		Temperature limit

Fig. 16-2 Symbols used on labeling

For symbols on the connection panel: See section 5.2.1: Connection panel, page 58.

## 16.4 Sample copy: Ikus Incoming Checklist

### IKUS INCOMING CHECKLIST



**Always refer to the Instructions for Use of EXCOR Pediatric VAD!**

Ikus LOT#: (located under red drive tube connection port) ..... – ..... Name of clinical site: .....

**Please ensure that the checklist below has been satisfactorily completed:**

Ikus driver and replacement driver are available	<input type="checkbox"/>	checked	
Remove Ikus drivers from crates and inspect for damage and/or broken parts	<input type="checkbox"/>		
Manual pump included (located and secured under laptop)	<input type="checkbox"/>		
Locate and inspect for the following accessories (either loose or in white box):			
⇒ Mains power supply cable	<input type="checkbox"/>	⇒ Keys	<input type="checkbox"/>
⇒ Envelope with default password	<input type="checkbox"/>	⇒ Connector Plug for External Alarm	<input type="checkbox"/>

**⚠** If the driver is damaged or there are missing parts:  
Do not use the driver. Notify Berlin Heart Clinical Affairs (866) 249 - 0128

#### Ikus driver initial start-up:

**Caution!** - Keep the driving tube connectors covered at all times when not in use.  
- The Ikus mains power switch (rocker switch) should always be in the ON/ EIN position – even when Ikus is in battery mode or is switched off (i.e. not in operation).

Connect the Ikus to the mains power (emergency outlet). Secure the mains cable with the plug clip on the Ikus driver. Ensure that the mains power switch (rocker switch) is set to ON/ EIN.	<input type="checkbox"/>	checked
Turn the key switch to the ON [I] position. The battery charge indicator (LED lights) will light up and the number of hours the driving unit has been operated to date will be displayed. The mains power indicator lights up.	<input type="checkbox"/>	
Switch on the laptop. The language selection menu appears. Select the desired language by pressing the corresponding number key. You do not have to press <Enter> to confirm this selection.	<input type="checkbox"/>	
The start menu is displayed on the laptop. Select the "Start program" option (<1>). Enter your user number and password. Confirm the password with <Enter>. Ikus will carry out a self-test. Wait for the test phase to be concluded (this takes several minutes). Do not acknowledge the acoustic signal. The messages in the message window will inform you of the status of the test. If Ikus is found to be operating correctly, the "Operating mode" view will be displayed next.	<input type="checkbox"/>	
Check that the batteries are adequately charged (full bar of LED lights).	<input type="checkbox"/>	
Shut down the monitoring program as instructed in the dialog window.	<input type="checkbox"/>	
When instructed in the message window, use the key switch to switch off Ikus. Important: The mains power switch (rocker switch) remains set to ON/ EIN.	<input type="checkbox"/>	

**⚠** If the Ikus has detected a fault during start-up or the self test:

An error message will appear in the message window. Switch the Ikus off, wait for at least 10 minutes, and begin the start procedure again as described above. If the error message persists, notify Berlin Heart Clinical Affairs: (866) 249 - 0128

#### Remarks:

..... Name ..... Signature ..... Date

Please complete and fax this form back to Berlin Heart, Inc.

Fax No: (877) 237 - 5464

# 16.5 Implantation record form



## IMPLANTATION RECORD FORM

EXCOR® VAD



This form applies **only** to USA and Canada

Please fill out the form (5 pages), and fax it to Berlin Heart, Inc. **immediately after implantation (fax: 866.540.5026)**  
 After replacing a blood pump, please fill out the "Pump Replacement" section (page 2), list the supplies used on page 3-5, and fax (5 pages) to Berlin Heart Inc. (fax: 866.540.5026)

### PATIENT INFORMATION

<b>Hospital</b>		<b>City/Country</b>	
<b>Patient's initials:</b>	Sex m <input type="checkbox"/> f <input type="checkbox"/>	Age:	Height [cm]      Weight [kg]
<b>Patient-No.:</b> <small>(BH Site No. followed by the patient No. ie: 004-103)</small>	<b>Indication</b> Ischemic CMP <input type="checkbox"/>	Idiopathic CMP <input type="checkbox"/>	Acute Myocarditis <input type="checkbox"/>
	Postcardiotomy <input type="checkbox"/>	Acute Myocardial Infarction <input type="checkbox"/>	
	Congenital <input type="checkbox"/>	..... Other <input type="checkbox"/>	.....

### PRE- IMPLANTATION CONDITION

<b>Urgency of implantation</b> elective <input type="checkbox"/> urgent <input type="checkbox"/> emergency <input type="checkbox"/>	<b>On ventilator</b> no <input type="checkbox"/> yes <input type="checkbox"/> since ..... (days)
<b>INTERMACS level</b>	<b>Other MCS</b> no <input type="checkbox"/> yes <input type="checkbox"/>
1 <input type="checkbox"/> Critical cardiogenic shock despite escalating support	IABP <input type="checkbox"/> since ..... (date)
2 <input type="checkbox"/> Progressive decline with inotropic dependence	ECMO <input type="checkbox"/> since ..... (date)
3 <input type="checkbox"/> Clinically stable with mild to moderate inotropic dependence	<b>Another VAD support</b> no <input type="checkbox"/> yes <input type="checkbox"/> since ..... (date)
4 <input type="checkbox"/> Recurrent, no refractory, advanced heart failure that can be stabilized with intervention	<b>On transplantation list</b> no <input type="checkbox"/> yes <input type="checkbox"/> since ..... (date)
5 <input type="checkbox"/> Exertion intolerant but is comfortable at rest and able to perform activities of daily living with slight difficulty	<b>CPR within 24h</b> no <input type="checkbox"/> yes <input type="checkbox"/> unknown <input type="checkbox"/>
6 <input type="checkbox"/> Exertion limited; is able to perform mild activity, but fatigue results within a few minutes of any meaningful physical exertion	<b>Dialysis/Hemofiltration within 72h</b> no <input type="checkbox"/> yes <input type="checkbox"/> unknown <input type="checkbox"/>
7 <input type="checkbox"/> Advanced NYHA functional class III	<b>History of stroke</b> no <input type="checkbox"/> yes <input type="checkbox"/> unknown <input type="checkbox"/>
	<b>History of prev. thor. surg.</b> no <input type="checkbox"/> yes <input type="checkbox"/> unknown <input type="checkbox"/>

### PRE- IMPLANTATION HEMODYNAMICS (most recent – if any parameter is not available please mark: n.a.)

<b>MAP</b> [mmHg]	<b>CVP</b> [mmHg]	<b>PAP mean</b> [mmHg]	<b>LVEDP</b> [mmHg]	<b>LVEF %</b> FS %
<b>Cardiac output</b> [l/min]	<b>Cardiac Index</b> [l/min/sqm]	<b>LVEDD</b> [mm]		

### IMPLANTATION DETAILS

<b>Implantation date</b> [mm/dd/yy]	<b>Surgeon</b> [name]	<b>Type</b> BVAD <input type="checkbox"/> LVAD <input type="checkbox"/> RVAD <input type="checkbox"/>	<b>Left-sided cannulation</b> apical <input type="checkbox"/> atrial <input type="checkbox"/>	<b>Pump type</b> Tilting-disk valve <input type="checkbox"/> PU valve <input type="checkbox"/>
<b>LVAD pump size:</b>	10 ml <input type="checkbox"/> 15 ml <input type="checkbox"/> 25 ml <input type="checkbox"/> 30 ml <input type="checkbox"/> 50 ml <input type="checkbox"/> 60 ml <input type="checkbox"/> 80 ml <input type="checkbox"/>			
<b>RVAD pump size:</b>	10 ml <input type="checkbox"/> 15 ml <input type="checkbox"/> 25 ml <input type="checkbox"/> 30 ml <input type="checkbox"/> 50 ml <input type="checkbox"/> 60 ml <input type="checkbox"/> 80 ml <input type="checkbox"/>			





Pump replacement

Left pump <input type="checkbox"/>	Reason for replacement .....
Date:	Location of deposit inflow valve <input type="checkbox"/> outflow valve <input type="checkbox"/> pump chamber <input type="checkbox"/>
Right pump <input type="checkbox"/>	Reason for replacement .....
Date:	Location of deposit inflow valve <input type="checkbox"/> outflow valve <input type="checkbox"/> pump chamber <input type="checkbox"/>

Device Explant

Date:	HTx <input type="checkbox"/> weaned <input type="checkbox"/> died <input type="checkbox"/> primary cause: .....
	Remarks: .....
	.....

SAMPLE



Please record the lot numbers of the used EXCOR® components and indicate the availability of replacement components and fax all to Berlin Heart, Inc. *immediately* after implantation (fax: 866.540.5026).

Hospital/City ..... Date of Implantation .....

Patient ID (BH Site No. followed by the patient No. ie: 004-103) .....

Ikus-No. .... Ikus hours of operation .....

Replacement Ikus available ? yes  no  Replacement Ikus hours of operation

Replacement Ikus-No. ....

Item	Article No.	Lot-No.		Replacement available ?	
		LVAD used	RVAD used	yes	no
<b>EXCOR Blood Pumps with PU valves</b>					
10 ml in/out Ø 6 mm	P10P-001			<input type="checkbox"/>	<input type="checkbox"/>
15 ml in/out Ø 9 mm	P15P-001			<input type="checkbox"/>	<input type="checkbox"/>
25 ml in/out Ø 9 mm	P25P-001x01			<input type="checkbox"/>	<input type="checkbox"/>
30 ml in/out Ø 9 mm	P30P-001x01			<input type="checkbox"/>	<input type="checkbox"/>
50 ml in/out Ø 12 mm	P50P-001			<input type="checkbox"/>	<input type="checkbox"/>
60 ml in/out Ø 12 mm	P60P-001			<input type="checkbox"/>	<input type="checkbox"/>
80 ml in/out Ø 12 mm	P80P-001***			<input type="checkbox"/>	<input type="checkbox"/>
<b>EXCOR Blood Pumps with Tilting-disk valves</b>					
50 ml in/out Ø 12 mm	P50M-001***			<input type="checkbox"/>	<input type="checkbox"/>
60 ml in/out Ø 12 mm	P60M-001***			<input type="checkbox"/>	<input type="checkbox"/>
80 ml in/out Ø 12 mm	P80M-001***			<input type="checkbox"/>	<input type="checkbox"/>
80 ml <b>out/in</b> Ø 12 mm (in/out exchanged)	P80M-005***			<input type="checkbox"/>	<input type="checkbox"/>
80 ml in/out Ø 16 mm	P80M-003***			<input type="checkbox"/>	<input type="checkbox"/>
80 ml <b>out/in</b> Ø 16 mm (in/out exchanged)	P80M-004***			<input type="checkbox"/>	<input type="checkbox"/>

\*\*\* Not available for general use in the US or Canada  
 +++ Not available for general use in the US



Item	Article No.	Lot-No.		Replacement available ?	
		LVAD used	RVAD used	yes	no
<b>EXCOR Apex Cannulae</b>					
Ø 5 mm, L 22 cm (Apex cannula for infants)	C14A-040			<input type="checkbox"/>	<input type="checkbox"/>
Ø 6 mm, L 25 cm (Apex cannula for small children)	C18A-020			<input type="checkbox"/>	<input type="checkbox"/>
Ø 12/9 mm, L 27 cm (Apex pediatric cannula, staged)	C22A-004			<input type="checkbox"/>	<input type="checkbox"/>
Ø 12 mm, L 26,5 cm (Apex cannula, one-piece)	C27A-001			<input type="checkbox"/>	<input type="checkbox"/>
Ø 16 mm, L 33 cm (Apex cannula)	C41A-050***			<input type="checkbox"/>	<input type="checkbox"/>
<b>EXCOR Atrial Cannulae</b>					
Ø 5 mm, L 20 cm, head 15 mm (Atrial cannula for infants)	C15V-040			<input type="checkbox"/>	<input type="checkbox"/>
Ø 6 mm, L 25 cm, head 19 mm (Atrial cannula, small children)	C19V-020			<input type="checkbox"/>	<input type="checkbox"/>
Ø 12/9 mm, L 28 cm, head 22 mm (Atrial ped. cannula, stag.)	C22V-004			<input type="checkbox"/>	<input type="checkbox"/>
Ø 12/9 mm, L 28 cm, head 25 mm (Atrial ped. cannula, stag.)	C25V-004			<input type="checkbox"/>	<input type="checkbox"/>
Ø 12 mm, L 33 cm, head 22 mm (Atrial cannula)	C22V-002			<input type="checkbox"/>	<input type="checkbox"/>
Ø 12 mm, L 33 cm, head 26 mm (Atrial cannula)	C26V-002			<input type="checkbox"/>	<input type="checkbox"/>
<b>EXCOR Arterial Cannulae</b>					
Ø 5 mm, L 20 cm (Arterial cannula for infants)	C80G-040			<input type="checkbox"/>	<input type="checkbox"/>
Ø 6 mm, L 25 cm (Arterial cannula for small children)	C80G-021			<input type="checkbox"/>	<input type="checkbox"/>
Ø 12/9 mm, L 26 cm (Graft-adapter ped. cannula, staged)	C00P-004+++			<input type="checkbox"/>	<input type="checkbox"/>
Ø 12/9 mm, L 28 cm, 85° (Arterial ped. cannula, staged)	C85G-004			<input type="checkbox"/>	<input type="checkbox"/>
Ø 12/9 mm, L 28 cm, 60° (Arterial ped. cannula, staged)	C60G-004			<input type="checkbox"/>	<input type="checkbox"/>
Ø 12 mm, L 33 cm, 60° (Arterial cannula)	C60G-002			<input type="checkbox"/>	<input type="checkbox"/>
Ø 12 mm, L 33 cm, 85° (Arterial cannula)	C85G-002			<input type="checkbox"/>	<input type="checkbox"/>
Ø 12 mm, L 26 cm (Graft-adapter cannula)	C00P-001+++			<input type="checkbox"/>	<input type="checkbox"/>
Ø 16/12 mm, L 36 cm, 85° (Arterial cannula, staged)	C85G-050+++			<input type="checkbox"/>	<input type="checkbox"/>
Ø 16 mm, L 26 cm (Graft-adapter cannula)	C00P-050+++			<input type="checkbox"/>	<input type="checkbox"/>

\*\*\* Not available for general use in the US or Canada

+++ Not available for general use in the US

Berlin Heart, Inc., 200 Valleywood Road, Suite B100  
The Woodlands, TX 77380  
[www.berlinheart.com](http://www.berlinheart.com)

Page 4 / 5

1000068x08



Item	Article No.	Lot-No.		Replacement available ?	
		LVAD used	RVAD used	yes	no
<b>Connecting Set for Cannulae</b>					
Ø 6/9 mm	A06-009			<input type="checkbox"/>	<input type="checkbox"/>
Ø 9/12 mm	A09-012			<input type="checkbox"/>	<input type="checkbox"/>
Ø 12/16 mm	A12-016***			<input type="checkbox"/>	<input type="checkbox"/>
<b>Cannula Extension Set</b>					
Ø 6/6 mm	A06-006			<input type="checkbox"/>	<input type="checkbox"/>
Ø 9/9 mm	A09-009			<input type="checkbox"/>	<input type="checkbox"/>
Ø 12/12 mm	A12-012			<input type="checkbox"/>	<input type="checkbox"/>
<b>Accessories</b>					
Accessory set Tilting-disk valves	T00L-001***			<input type="checkbox"/>	<input type="checkbox"/>
Accessory set PU-valves	T00L-002			<input type="checkbox"/>	<input type="checkbox"/>
Driving tube, red Ø 6/8 mm, L 2 m	L20H-002			<input type="checkbox"/>	<input type="checkbox"/>
Driving tube, blue Ø 6/8 mm, L 2 m	L20H-003			<input type="checkbox"/>	<input type="checkbox"/>
Tank unit	1600422			<input type="checkbox"/>	<input type="checkbox"/>

\*\*\* Not available for general use in the US or Canada  
 +++ Not available for general use in the US

<b>Date</b>	<b>Signature</b>
_____	_____
<b>Name</b>	<b>Contact Phone No.</b>
_____	_____

## 16.6 Sample copy: EXCOR pump log

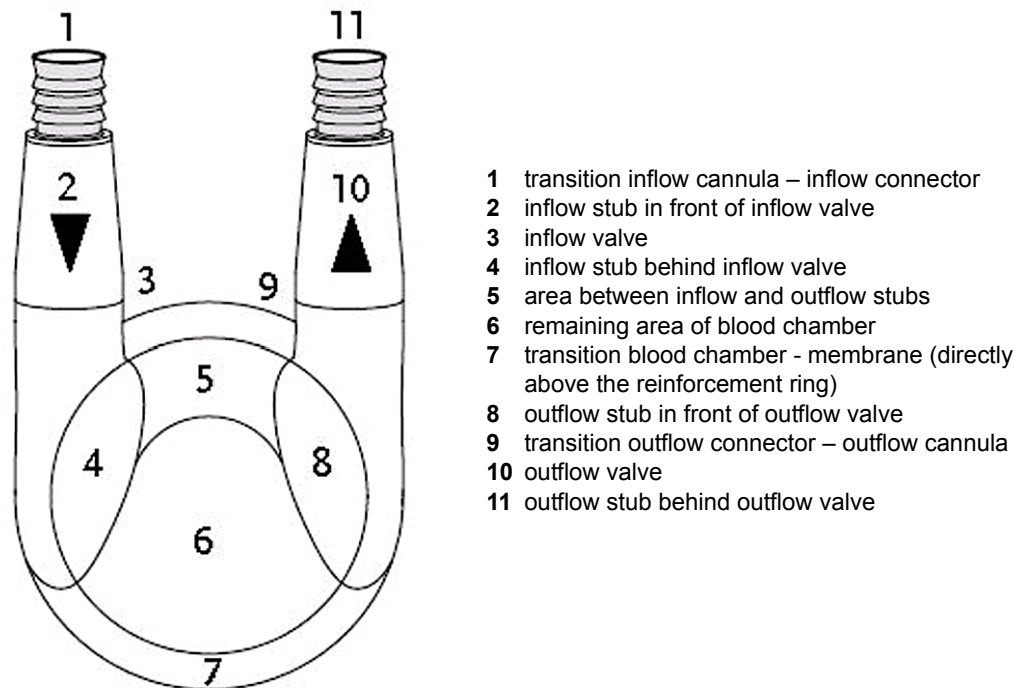

Fig. 16-3 EXCOR blood pump with checkpoint numbers



To briefly describe the findings, use the following letter codes:

p	small punctual deposit	f	small strand
P	large punctual deposit	F	large strand
a	small area of deposit	t	small thrombus
A	large area of deposit	T	large thrombus
~ above the respective letter indicates floating deposits			

Tab. 16-12 Notation for letter code

**Example: Plotting of the deposits**

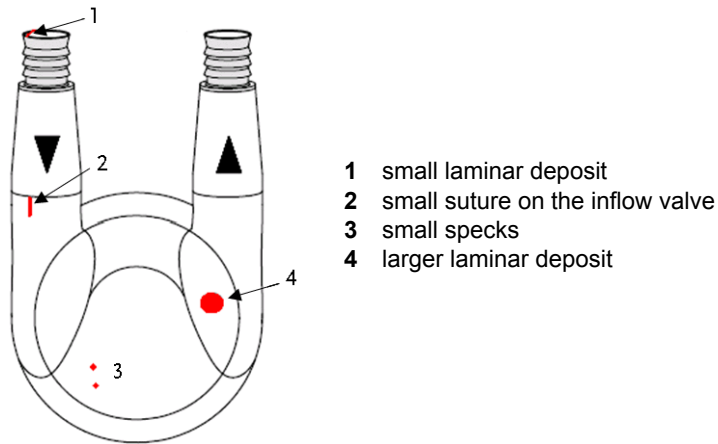

- 1 small laminar deposit
- 2 small suture on the inflow valve
- 3 small specks
- 4 larger laminar deposit

**Fig. 16-4** Plotting of the deposits

**Example: Notation with letter code**

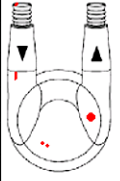
			Linke Pumpe/ Left pump	ml: 50ml		No.: 0815									
Datum date	Zeit time	Name Sign.		1	2	3	4	5	6	7	8	9	10	11	
01.01.	8:00	z.B.			a		F			p		A			

**Fig. 16-5** Example: Notation with letter code

			Linke Pumpe/ Left pump		ml:		No.:		Rechte Pumpe/ Right pump		ml:		No.:												
Datum date	Zeit time	Name Sign.	1	2	3	4	5	6	7	8	9	10	11	1	2	3	4	5	6	8	7	9	10	11	





## 17 EMC tables

### 17.1 Essential Performance

The following essential performance was verified in the electromagnetic immunity tests: The driving unit must drive the EXCOR blood pumps with the set parameters. This was controlled by monitoring the following acceptance criteria:

- The pump rate may not deviate by more than 10% or 50 ms (the higher value is valid).
- The relative systolic duration may not deviate by more than 10% or 50 ms (the higher value is valid).
- The driving pressure in engaged condition at the end of the systole or diastole may not deviate by more than 10% or 20 mmHg (the higher value is valid).
- No failure alarms may occur.
- No undesired change may occur between mains and battery operation.
- In battery operation the battery alarms must occur correctly.
- No switch to emergency pulse mode may occur.

### 17.2 Electromagnetic emissions

The Ikus is intended for use in the electromagnetic environment specified below. The customer or the user of the Ikus should ensure that Ikus is used in such an environment

Emissions test	Compliance	Electromagnetic environment - guidance
RF emissions CISPR 11	Group 1	The Ikus uses RF energy only for its internal function. Therefore, its RF emissions are very low and are not likely to cause any interference in nearby electronic equipment.
RF emissions CISPR 11	Class B	The Ikus is suitable for use in all establishments, including domestic establishments and those directly connected to the public low-voltage power supply network that supplies buildings used for domestic purposes.
Harmonic emissions IEC 61000-3-2	Class A	
Voltage fluctuations/ flicker emissions IEC 61000-3-3	Complies	

Tab. 17-1 Emissions characteristics

### 17.3 Electromagnetic immunity - part 1

The Ikus is intended for use in the electromagnetic environment specified below. The customer or the user of the Ikus should ensure that it is used in such an environment.

Immunity test	IEC 60601 test level	Compliance level	Electromagnetic environment -guidance
Electrostatic discharge (ESD) IEC 61000-4-2	± 6 kV contact ± 8 kV air	± 6 kV contact ± 8 kV air	Floors should be wood, concrete or ceramic tile. If floors are covered with synthetic material, the relative humidity should be at least 30 %.
Electrical fast transient / burst IEC 61000-4-4	± 2 kV for power supply lines ± 1 kV for input/output lines	± 2 kV for power supply lines ± 1 kV for input/output lines	Mains power quality should be that of a typical commercial or hospital environment.
Surge IEC 61000-4-5	± 1 kV line(s) to line(s) ± 2 kV line(s) to earth	± 1 kV line(s) to line(s) ± 2 kV line(s) to earth	Mains power quality should be that of a typical commercial or hospital environment.
Voltage dips, short interruptions and voltage variations on power supply input lines IEC 61000-4-11	< 5 % UT (>95 % dip in UT) for 0.5 cycle 40 % UT (60 % dip in UT) for 5 cycles 70 % UT (30 % dip in UT) for 25 cycles < 5 % UT (>95 % dip in UT) for 5 sec	< 5 % UT (>95 % dip in UT) for 0.5 cycle 40 % UT (60 % dip in UT) for 5 cycles 70 % UT (30 % dip in UT) for 25 cycles < 5 % UT (>95 % dip in UT) for 5 sec	Mains power quality should be that of a typical commercial or hospital environment. If the user of the Ikus requires continued operation during power mains interruptions, it is recommended that the Ikus be powered from an uninterruptible power supply or a battery.
Power frequency (50/60 Hz) magnetic field IEC 61000-4-8	3 A/m	100 A/m	The Ikus can be used up to 1 m from power cables carrying up to 100 A.
NOTE U <sub>T</sub> is the a.c. mains voltage prior to application of the test level.			

Tab. 17-2 Electromagnetic immunity - part 1

## 17.4 Electromagnetic immunity - part 2

The Ikus is intended for use in the electromagnetic environment specified below. The customer or the user of the Ikus should ensure that it is used in such an environment

Immunity test	IEC 60601 test level	Compliance level	Electromagnetic environment - guidance
			<p>Portable and mobile RF communications equipment should be used no closer to any part of the Icus, including cables, than the recommended separation distance calculated from the equation applicable to the frequency of the transmitter.</p> <p>Recommended separation distance</p>
Conducted RF IEC 61000-4-6	3 V <sub>rms</sub> 150 kHz to 80 MHz outside ISM bands <sup>a</sup>	10 V	$d=0.35\sqrt{P}$
	10 V <sub>rms</sub> 150 kHz to 80 MHz in ISM bands <sup>a</sup>	10 V	$d=1.2\sqrt{P}$
Radiated RF IEC 61000-4-3	10 V/ m 80 MHz to 2,5 GHz	30 V/m 80 MHz to 6 GHz	$d=0.4 \sqrt{P}$ 80 MHz to 800 MHz $d=0.77\sqrt{P}$ 800 MHz to 2,5 GHz
			<p>Where P is the maximum output power rating of the transmitter in watts (W) according to the transmitter manufacturer and d is the recommended separation distance in metres (m).<sup>b</sup></p> <p>Field strengths from fixed RF transmitters, as determined by an electromagnetic site survey,<sup>c</sup> should be less than the compliance level in each frequency range.<sup>d</sup></p> <p>Interference may occur in the vicinity of equipment marked with the following symbol:</p> <div style="text-align: center;">  </div>

Tab. 17-3 Electromagnetic immunity - part 2

Immunity test	IEC 60601 test level	Compliance level	Electromagnetic environment - guidance
NOTE 1: At 80 MHz and 800 MHz, the higher frequency range applies.			
NOTE 2: These guidelines may not apply in all situations. Electromagnetic propagation is affected by absorption and reflection from structures, objects and people.			

**Tab. 17-3** Electromagnetic immunity - part 2

- a) The ISM (industrial, scientific and medical) bands between 150 kHz and 80 MHz are 6.765 MHz to 6.795 MHz; 13.553 MHz to 13.567 MHz; 26.957 MHz to 27.283 MHz; and 40.66 MHz to 40.70 MHz.
- b) The compliance levels in the ISM frequency bands between 150 kHz and 80 MHz and in the frequency range 80 MHz to 2.5 GHz are intended to decrease the likelihood that mobile/portable communications equipment could cause interference if it is inadvertently brought into patient areas. For this reason, an additional factor of 10/3 has been incorporated into the formulae used in calculating the recommended separation distance for transmitters in these frequency ranges.
- c) Field strengths from fixed transmitters, such as base stations for radio (cellular/cordless) telephones and land mobile radios, amateur radio, AM and FM radio broadcast and TV broadcast cannot be predicted theoretically with accuracy. To assess the electromagnetic environment due to fixed RF transmitters, an electromagnetic site survey should be considered. If the measured field strength in the location in which the Ikus is used exceeds the applicable RF compliance level above, the Ikus should be observed to verify normal operation. If abnormal performance is observed, additional measures may be necessary, such as re-orienting or relocating the Ikus.
- d) Over the frequency range 150 kHz to 80 MHz, field strengths should be less than 10V/m.

### 17.5 Recommended separation distances between portable and mobile RF communications equipment and the Ikus

The Ikus is intended for use in an electromagnetic environment in which radiated RF disturbances are controlled. The customer or the user of the Ikus can help prevent electromagnetic interference by maintaining a minimum distance between portable and mobile RF communications equipment (transmitters) and the Ikus as recommended below, according to the output power of the communications equipment.

Rated maximum output power of transmitter [W]	Separation distance according to frequency of transmitter [m]			
	150 kHz to 80 MHz outside ISM bands $d=0,35\sqrt{P}$	150 kHz to 80 MHz in ISM bands $d=1,2\sqrt{P}$	80 MHz to 800 MHz $d = 0.4 \sqrt{P}$	800 MHz to 6 GHz $d = 0.77 \sqrt{P}$
0.01	0.04	0.12	0.04	0.08
0.1	0.11	0.38	0.13	0.24
1	0.4	1.2	0.4	0.8
10	1.11	3.8	1.3	2.4
100	3.5	12	4	7.7
For transmitters rated at a maximum output power not listed above, the recommended separation distance $d$ in metres [m] can be determined using the equation applicable to the frequency of the transmitter, where $P$ is the maximum output power rating of the transmitter in watts [W] according to the transmitter manufacturer.				

**Tab. 17-4** Separation distance depending on frequency of transmitter

- NOTE 1 At 80 MHz and 800 MHz, the separation distance for the higher frequency range applies.
- NOTE 2 The ISM (industrial, scientific and medical) bands between 150 kHz and 80 MHz are 6.765 MHz to 6.795 MHz; 13.553 MHz to 13.567 MHz; 26.957 MHz to 27.283 MHz; and 40.66 MHz to 40.70 MHz.
- NOTE 3 An additional factor of 10/3 has been incorporated into the formulae used in calculating the recommended separation distance for transmitters in the ISM frequency bands between 150 kHz and 80 MHz and in the frequency range 80 MHz to 2.5 GHz to decrease the likelihood that mobile/portable communications equipment could cause interference if it is inadvertently brought into patient areas.
- NOTE 4 These guidelines may not apply in all situations. Electromagnetic propagation is affected by absorption and reflection from structures, objects and people.

*This page was left blank intentionally*

# Index

## A

access passwords	65
accessories	
description - blood pump, cannulae, ~	53
EXCOR components and ~	109
EXCOR Pediatric ~	55
system ~	215
accessory set	
for blood pumps with PU valves	109, 215
for commissioning and operation	55
adverse events	20
alarm	
external ~ connector	219
ambient temperature	14
in operation	217
anticoagulation	
status	143, 191
asynchronous pulse	
in biventricular operating mode	74
seperate pulsing left/right	62
Audio paused	61

## B

battery	
~ charging time	219
switching over to ~ operating mode	80
toggle between mains and ~ operation	79
biventricular	
adjusting the operating mode in ~ operation	104
anastomosis	128
assignment	101
changing from univentricular to ~	82
changing from univentricular to ~ operation	82
dysfunction	21
emergency pulse mode	64
explantation after ~ support	167
manual pump in ~ mode	65
operating mode	62
pneumatic system redundancy in ~ operation	64
selecting operating mode	77
stopping an individual blood pump	78
test parameter	96
blood pump	
biventricular operation	62
connecting the ~ to the cannulae	128
connecting the ~ to the lkus	101
connecting to the replacement lkus	203
consists of ...	21
de-airing	112
EXCOR Pediatric ~	54
operation period	4, 22
preparing a replacement ~	195
regular checks of ~	141
replacing	195
rinse and fill the ~	113
stopping	77
stopping an individual ~	78

univentricular operation	62
blood pump(s)	
driving a ~ with the manual pump	204
BVAD	
anastomosis of the cannulae	116
BVAD see biventricular	

## C

Cannula	
extension set	118
cannula tunneling tip	117
available sizes of ~	117
use of ~	117
cannulae	
apex ~	121
atrial ~	124
atrial ~ with mandrin	112
description	53
EXCOR Pediatric ~	54
outflow ~	126
regular checks of the ~	141
shortening	128
technical specifications	218
types of ~	54
Which ~ should be used for which pump?	214
cardiac transplantation	21
Carmeda® BioActive Surface	8, 54
cautionary measures	
adjusting the parameter values	142
EMC	17, 18
filling behavior of the blood pump(s)	141
monitor program	73
visual inspection - deposits	143
checks	
~using the monitor program	143
regular ~ of blood pumps and cannulae	141
components	
and accessories	109
permanently active ~	53
preparing the ~ and materials required	109
Connecting set	118
connection panel	58, 94
contraindications	22
control computer	57
breakdown of both ~s	206
emergency operating mode	200
redundant design	64

## D

de-airing	
~ hammer	8
~ needle, figure	113
~ nipple, figure	112
~ set	55, 109, 112, 215
~ step	102
~hammer	55, 109
inserting the ~ needle	113
removing the ~ needle	130

deposits	
~ in the pump .....	191
floating .....	191
visual inspection .....	142
display and operating panel .....	61
dressing	
applying a new ~ .....	138
removing the old ~ .....	136
driving pressure	
possible range .....	104
systolic .....	21
driving tube .....	53
as an active component .....	53
connector .....	54
connector, figure .....	112
function .....	53
in univentricular operation .....	62
on the tank unit .....	95
replacing .....	174
driving tube connector .....	54

## E

echocardiogram, intraoperative trans-esophageal ...	133
electro-stimulation therapy .....	18
EMC	
special precautions required .....	17, 18
EMC tables .....	231
emergency operating mode .....	64, 200
Ikus start-test following ~ .....	201
restarting Ikus in ~ .....	198
equipotential bonding connector .....	94
error message	
acknowledging .....	172
what to do? .....	171
Essential Performance .....	231
events, adverse .....	20
examination, medical ~ of patient .....	141
EXCOR Pediatric .....	109
EXCOR Pediatric HDE Study .....	195
explantation	
~ after biventricular support .....	167
~ after univentricular support .....	167
external alarm	
~ connector .....	219
~ connector, figure .....	94

## H

hours of use .....	14
--------------------	----

## I

identification plate .....	6
Ikus	
commissioning the ~ and setting parameters	93
description, Stationary Driving Unit Ikus .....	57
device description .....	21
instructions for use .....	67
moving the ~ .....	84
product life time .....	219
recommended separation distances .....	234

implantation	
anesthesia .....	133
infection .....	135
risk of ~ .....	135
to prevent ~ .....	9
inspection	
filling behavior of blood pump .....	141
frequency of ~ .....	141
of pump areas which come in contact with blood	143
visual ~ - deposits .....	142
instruction and care of the patient .....	20
interaction with other procedures and therapies ..	17

## K

key switch (main switch)	
and power switch (toggle switch) .....	60
figure .....	94
restart the Ikus .....	188
switching on the Ikus .....	95

## L

laptop	
~ computer with monitor program .....	57, 63
start menu .....	68
use of ~ .....	67
LOG files, reading out the ~ .....	207
LVAD	
~ anastomosis .....	128
~ anesthesia .....	133
~ assignment .....	101

## M

main switch (key switch)	
figure .....	94
mains power operation	
mains power cable .....	80
switching over to ~ .....	82
toggle between ~ and battery operation .....	79
maintenance .....	202
~ interval .....	219
manual pump	
driving a blood pump with the ~ .....	204
purpose .....	58, 65
membrane set .....	55, 109
message window .....	95, 171
browsing in the ~ .....	77
mobilization .....	142
monitor program .....	67
basic instructions .....	71
functions .....	74
laptop computer with ~ .....	57, 63
logging in and out of the ~ .....	72
shutting down the ~ .....	72
standard view .....	73
start menu .....	68
starting .....	71
monitoring	
~ procedure .....	133



---

**N**

nuclear	
~ diagnostics .....	18
~ therapy .....	18
numlock	
deactivated at the start .....	67, 94

---

**O**

obturator .....	113
operating hours, see hours of use	
operating mode .....	101
biventricular operation .....	62
emergency .....	64
selecting the ~ .....	97
synchronous pulse .....	74
univentricular operation .....	62

---

**P**

packaging	
and sterilization .....	7
and transportation .....	84
sterile ~ .....	111
parameter	
adjusting .....	104
adjusting the ~ values .....	76, 142
adjustment, possible range .....	104
checking the ~s when the pump is started and adjusting them .....	103
commissioning the Ikus and setting ~s .....	93
set the start-up ~s .....	100
set the test ~s .....	95
table .....	74, 76
test ~s .....	96
password	
~protected user profiles .....	65
envelope .....	69
options in the start menu .....	69
platelet concentrates .....	18, 133
product range and possible combinations .....	211
power supply .....	61
failure .....	194, 204
mains ~ .....	62
mains power failure or breakdown of both control computers .....	206
power switch, see toggle switch	
pulsing	
asynchronous, left/right .....	62
independent, left/ right .....	62
synchronous, left/ right .....	62
pump log	
explanations on the EXCOR Pediatric ~ .....	227
pump size	
pop-up menu for selcting the ~ .....	98
relationship between bodyweight and ~ .....	211
selecting the ~ .....	98
pump, see blood pump .....	21

---

**R**

radiotherapy .....	17, 18
--------------------	--------

---

replacing blood pump .....	195
restart Ikus (in emergency operation mode) .....	198

---

**S**

safety risks .....	20
selecting pump size(s) and cannula sizes .....	75
self-test of the alarm circuit .....	72
separate mode	
biventricular operating mode .....	74
single-step mode	
figure .....	102
removing air from the blood pump(s) in ~ ..	102
SRS_691 .....	118
standard default parameters .....	95
start-up test	
error messages during ~ .....	83
following emergency operating mode .....	201
routine ~ when not in operation .....	83
sterilization and packaging .....	7
storage .....	217
and durability .....	20
suction pressure, diastolic .....	21
possible range .....	104
synchronous pulse .....	74, 96
in emergency operating mode .....	64
synchronous pulsing left/right .....	62

---

**T**

tank unit .....	93
connecting .....	94
disconnect the ~ from the Ikus .....	97
test parameters	
setting the ~ .....	95
table .....	96
time error, see error messages	
toggle switch .....	199
toggle switch (power switch) .....	94
during transportation .....	85
main switch and power switch .....	60
switch off the Ikus .....	78
switch on the Ikus .....	95
transport .....	217
outside the clinic .....	20
proceeding after ~ .....	20, 93
within the clinic .....	84
treatment and wound care .....	135
Trendelenburg position .....	102, 129, 196, 197
trocar	
as part of the de-airing set .....	109
figure .....	113
to de-air the blood pump .....	112

---

**U**

ultrasonic treatment .....	18
univentricular	
anastomosis .....	128
assignment .....	101
operation .....	62
overview, assignment .....	101
which driving tube? .....	109

user profile .....	65
UVAD see also univentricular	
UVAD, univentricular	
change over from ~ to biventricular operation	82
default settings .....	203
explantation after ~ support .....	167
redundant design of pneumatic systems .....	63

---

## V

valves	
control ~ .....	57
three-leaflet polyurethane ~ .....	21
visual inspection	
deposits .....	142
filling and ejecting of the blood pump .....	14
filling behavior of blood pump .....	141
regular ~ of blood pumps and cannulae .....	141

---

## W

wound care .....	135
and treatment .....	135

---

## X

X-rays .....	18
--------------	----