

	<b>GLOBAL STANDARD</b>	Page 1 of 39
	<b>LOW VOLTAGE FUSES (NH Knife Blade Fuse System)</b>	<b>GSC004 Rev. 0 23/11/2016</b>

**LOW VOLTAGE FUSES  
(NH Knife Blade Fuse System)**

Countries' I &N	Elaborated by
Brazil	V. Robadey
Chile	F. Perez
Colombia	M. Sarmiento
Spain	J. Doncel
Italy	L. Giansante
Peru	J. Taboada
Romania	M. Domnicu

	Elaborated by	Verified by	Approved by
Solution Development Center	<b>L. Giansante</b>	<b>L. Giansante</b>	<b>I. Gentilini</b>
Global I&N - NT/NCS		<b>N. Cammalleri G. Egea</b>	<b>F. Giammanco</b>

This document is intellectual property of Enel Spa; reproduction or distribution of its contents in any way or by any means whatsoever is subject to the prior approval of the above mentioned company which will safeguard its rights under the civil and penal codes.

This document is for Internal Use.

Revision	Date	List of modifications
0	23/11/2016	First edition



INDEX

1	SCOPE.....	5
2	APPLICATION FIELD.....	5
3	DEFINITIONS.....	6
4	LIST OF COMPONENTS .....	6
5	REFERENCE LAWS AND STANDARDS .....	8
5.1	Laws .....	8
5.1.1	LATAM.....	8
5.1.2	Italy .....	8
5.1.3	Spain.....	8
5.2	Standards .....	9
5.2.1	Common standards .....	9
5.2.2	Specific standards.....	9
6	OPERATIONAL CONDITIONS .....	9
6.1	Ambient air temperature (Ta).....	10
6.2	Altitude .....	10
6.3	Atmospheric conditions.....	10
6.4	Voltage .....	10
6.5	Discrimination of fuse-links.....	10
6.6	Specific operational conditions.....	11
7	RATED CHARACTERISTICS .....	11
7.1	Rated Voltage.....	11
7.2	Rated current .....	11
7.2.1	Rated current of the fuse-link .....	11
7.2.2	Rated current of the fuse-holder .....	11
7.3	Rated frequency.....	12
7.4	Rated power dissipation of a fuse-link and rated acceptable power dissipation of a fuse-holder.....	12
7.5	Limits of time-current characteristics .....	13
7.5.1	Time-current characteristics, time-current zones .....	13
7.5.2	Conventional times and currents .....	14
7.5.3	Gates .....	14



7.5.4	Breaking range and utilization category .....	14
7.5.5	Rated breaking capacity.....	15
7.6	Cut-off current and I <sup>2</sup> t characteristics .....	18
8	CONDITIONS FOR CONSTRUCTION .....	18
8.1	Mechanical design for NH type fuses.....	18
8.1.1	Connections, included terminals.....	24
8.1.2	Fuse contacts .....	25
8.1.3	Construction of fuse-link .....	25
8.2	Mechanical design of fuses NH L type.....	25
8.3	Insulating properties omega .....	26
8.4	Temperature rise, power dissipation of the fuse-link and acceptable power dissipation of a fuse-holder.....	26
8.5	Operation.....	28
8.6	Cut-off current characteristics and I <sup>2</sup> t characteristics .....	28
8.7	Overcurrent discrimination of fuse-links “gG” type.....	29
8.8	Protection against electric shock.....	29
8.9	Resistance to heat .....	29
8.10	Mechanical strength .....	30
8.11	Resistance to corrosion .....	30
8.11.1	Resistance to rusting .....	30
8.11.2	Resistance to season cracking.....	30
8.12	Resistance to abnormal heat and fire .....	30
9	MARKINGS .....	30
9.1	Marking of fuse-holders .....	30
9.2	Marking of fuse-links .....	31
9.3	Designation .....	31
9.3.1	Designation of fuse-bases .....	31
9.3.2	Designation of fuse-links .....	32
10	PACKAGING.....	32
11	EXCEPTIONS TO THIS SPECIFICATION .....	32
12	TESTING .....	32
12.1	General .....	33
12.2	Type-approval tests.....	33
12.3	Acceptance tests .....	36

	<b>GLOBAL STANDARD</b>	Page 4 of 39
	<b>LOW VOLTAGE FUSES (NH Knife Blade Fuse System)</b>	<b>GSC004</b> Rev. 0 23/11/2016

<b>13</b>	<b>ANNEX A .....</b>	<b>37</b>
<b>14</b>	<b>ANNEX B .....</b>	<b>38</b>

	<b>GLOBAL STANDARD</b>	Page 5 of 39
	<b>LOW VOLTAGE FUSES (NH Knife Blade Fuse System)</b>	<b>GSCL004 Rev. 0 23/11/2016</b>

## 1 SCOPE

The scope of this document is to provide the technical requirements for the supply of LV fuses and its components parts (fuse-base, fuse-carrier, fuse link) used as protection devices for LV Distribution System in the Enel Group Distribution companies listed below:

- Ampla (Brazil)
- Chilectra (Chile)
- Codensa (Colombia)
- Coelce (Brazil)
- Edelnor (Peru)
- Edesur (Argentina)
- Endesa Distribución Eléctrica (Spain)
- Enel Distributie Banat (Romania)
- Enel Distributie Dobrogea (Romania)
- Enel Distributie Muntenia (Romania)
- e-distribuzione (Italy)

Note: the indication "LATAM" refers to the Enel Group Distribution companies in South America.

Some requirements are applicable only to one or more companies. Therefore, depending on the destination, the supplied equipment shall comply with these specific requirements.

## 2 APPLICATION FIELD

This standard apply to high breaking capacity fuses, more commonly known as NH type fuses (the name comes from its German acronym, Niederspannungs-Hochleistungs-Sicherungen, o NH-Sicherungen), and to a variant which we will call NHL Type. These fuses must incorporate enclosed current-limiting fuse links with rated breaking capacities of not less than 50 kA, and will be intended for protecting power frequency a.c. circuits of nominal voltages not exceeding 1 000 V or d.c. circuits of nominal voltages not exceeding 1 500 V.

The fuses considered in this standard must have a rated current lower than or equal to 1250 A and a rated voltage lower than or equal to 690 V a.c. or 440 V d.c.

For the purpose aforementioned, the following characteristics of fuses are particularly treated:

- a) their rated values
- b) their insulation
- c) their temperature rise in normal service
- d) their power dissipation and acceptable power dissipation
- e) their time/current characteristics
- f) their breaking capacity
- g) their cut-off current characteristics and their  $I^2 \times t$  characteristics
- h) type test for verification of the characteristics of fuses
- i) the marking of fuses

Note: this document must be applied jointly with IEC 60269-1 and IEC 60269-2 standards.

	<b>GLOBAL STANDARD</b>	Page 6 of 39
	<b>LOW VOLTAGE FUSES (NH Knife Blade Fuse System)</b>	<b>GSC004</b> <b>Rev. 0</b> <b>23/11/2016</b>

### 3 DEFINITIONS

For the purposes of this standard, the following terms and definitions apply:

NOTE: For general definitions concerning fuses, see also IEC 60050-441 standard.

**Fuse:** Device that by the fusing of one or more of its specially designed and proportioned components opens the circuit in which it is inserted by breaking the current when this exceeds a given value for a sufficient time. The fuse comprises all the parts that form the complete device

**Fuse-holder:** Combination of the fuse-base with its fuse-carrier. (Where, in this standard, the term "fuse-holder" is used, it covers fuse-bases and/or fuse-carriers, if no clearer distinction is necessary).

**Fuse-base:** Fixed part of a fuse provided with contacts and terminals. (When applicable, the covers are considered as part of the fuse-base).

**Fuse-carrier:** Movable part of a fuse designed to carry a fuse-link.

**Fuse-link:** Part of a fuse including the fuse-element(s), intended to be replaced after the fuse has operated.

**Fuse-contact:** Two or more conductive parts designed to ensure circuit continuity between a fuse-link and the corresponding fuse-holder.

**Fuse-element:** Part of the fuse-link designed to melt under the action of current exceeding some definite value for a definite period of time. (The fuse-link may comprise several fuse-elements in parallel).

**Indicating device (indicator):** Part of a fuse provided to indicate whether the fuse has operated.

**Current-limiting fuse-link (current-limiting fuse):** Fuse-link that during and by its operation in a specified current range, limits the current to a substantially lower value than the peak value of the prospective current.

**"g" fuse-link ("g" fuse):** (full-range breaking-capacity fuse-link, formerly general purpose fuse-link). Current-limiting fuse-link capable of breaking under specified conditions all currents, which cause melting of the fuse-element up to its rated breaking capacity.

### 4 LIST OF COMPONENTS

Although the characteristics of the complete fuses are specified in the present standard, including all its components parts (fuse-base, fuse-carrier, fuse link), the components codes listed in this document refers only to fuse-links.

The fuse-links specified in this standard are those included in **Table 1**.



**Table 1 - List of components**

TYPE CODE	DESCRIPTION	SIZE	CLASS	In (A)
GSCL004/01	LV NH KNIFE BLADE FUSE SIZE 00 CLASS "gG" 25 A	00	gG	25
GSCL004/02	LV NH KNIFE BLADE FUSE SIZE 00 CLASS "gG" 50 A	00	gG	50
GSCL004/03	LV NH KNIFE BLADE FUSE SIZE 00 CLASS "gG" 63 A	00	gG	63
GSCL004/04	LV NH KNIFE BLADE FUSE SIZE 00 CLASS "gG" 80 A	00	gG	80
GSCL004/05	LV NH KNIFE BLADE FUSE SIZE 00 CLASS "gG" 100 A	00	gG	100
GSCL004/06	LV NH KNIFE BLADE FUSE SIZE 00 CLASS "gG" 125 A	00	gG	125
GSCL004/07	LV NH KNIFE BLADE FUSE SIZE 00 CLASS "gG" 160 A	00	gG	160
GSCL004/08	LV NH KNIFE BLADE FUSE SIZE 0 CLASS "gG" 40 A	0	gG	40
GSCL004/09	LV NH KNIFE BLADE FUSE SIZE 0 CLASS "gG" 50 A	0	gG	50
GSCL004/10	LV NH KNIFE BLADE FUSE SIZE 0 CLASS "gG" 63 A	0	gG	63
GSCL004/11	LV NH KNIFE BLADE FUSE SIZE 0 CLASS "gG" 80 A	0	gG	80
GSCL004/12	LV NH KNIFE BLADE FUSE SIZE 0 CLASS "gG" 100 A	0	gG	100
GSCL004/13	LV NH KNIFE BLADE FUSE SIZE 0 CLASS "gG" 125 A	0	gG	125
GSCL004/14	LV NH KNIFE BLADE FUSE SIZE 0 CLASS "gG" 160 A	0	gG	160
GSCL004/15	LV NH KNIFE BLADE FUSE SIZE 1 CLASS "gG" 63 A	1	gG	63
GSCL004/16	LV NH KNIFE BLADE FUSE SIZE 1 CLASS "gG" 80 A	1	gG	80
GSCL004/17	LV NH KNIFE BLADE FUSE SIZE 1 CLASS "gG" 100 A	1	gG	100
GSCL004/18	LV NH KNIFE BLADE FUSE SIZE 1 CLASS "gG" 125 A	1	gG	125
GSCL004/19	LV NH KNIFE BLADE FUSE SIZE 1 CLASS "gG" 160 A	1	gG	160
GSCL004/20	LV NH KNIFE BLADE FUSE SIZE 1 CLASS "gG" 200 A	1	gG	200
GSCL004/21	LV NH KNIFE BLADE FUSE SIZE 1 CLASS "gG" 250 A	1	gG	250
GSCL004/22	LV NH KNIFE BLADE FUSE SIZE 2 CLASS "gG" 50 A	2	gG	50
GSCL004/23	LV NH KNIFE BLADE FUSE SIZE 2 CLASS "gG" 63 A	2	gG	63
GSCL004/24	LV NH KNIFE BLADE FUSE SIZE 2 CLASS "gG" 80 A	2	gG	80
GSCL004/25	LV NH KNIFE BLADE FUSE SIZE 2 CLASS "gG" 100 A	2	gG	100
GSCL004/26	LV NH KNIFE BLADE FUSE SIZE 2 CLASS "gG" 125 A	2	gG	125
GSCL004/27	LV NH KNIFE BLADE FUSE SIZE 2 CLASS "gG" 160 A	2	gG	160
GSCL004/28	LV NH KNIFE BLADE FUSE SIZE 2 CLASS "gG" 200 A	2	gG	200
GSCL004/29	LV NH KNIFE BLADE FUSE SIZE 2 CLASS "gG" 250 A	2	gG	250
GSCL004/30	LV NH KNIFE BLADE FUSE SIZE 2 CLASS "gG" 315 A	2	gG	315
GSCL004/31	LV NH KNIFE BLADE FUSE SIZE 2 CLASS "gG" 400 A	2	gG	400
GSCL004/32	LV NH KNIFE BLADE FUSE SIZE 3 CLASS "gG" 315 A	3	gG	315
GSCL004/33	LV NH KNIFE BLADE FUSE SIZE 3 CLASS "gG" 400 A	3	gG	400
GSCL004/34	LV NH KNIFE BLADE FUSE SIZE 3 CLASS "gG" 500 A	3	gG	500
GSCL004/35	LV NH KNIFE BLADE FUSE SIZE 3 CLASS "gG" 630 A	3	gG	630
GSCL004/36	LV NHL KNIFE BLADE FUSE SIZE 1 CLASS "gG" 40 A	1	gG	40
GSCL004/37	LV NHL KNIFE BLADE FUSE SIZE 1 CLASS "gG" 63 A	1	gG	63

	<b>GLOBAL STANDARD</b>	Page 8 of 39
	<b>LOW VOLTAGE FUSES (NH Knife Blade Fuse System)</b>	<b>GSCL004 Rev. 0 23/11/2016</b>

GSCL004/38	LV NHL KNIFE BLADE FUSE SIZE 1 CLASS "gG" 80 A	1	gG	80
GSCL004/39	LV NHL KNIFE BLADE FUSE SIZE 1 CLASS "gG" 100 A	1	gG	100
GSCL004/40	LV NHL KNIFE BLADE FUSE SIZE 1 CLASS "gG" 160 A	1	gG	160
GSCL004/41	LV NHL KNIFE BLADE FUSE SIZE 1 CLASS "gG" 200 A	1	gG	200
GSCL004/42	LV NHL KNIFE BLADE FUSE SIZE 1 CLASS "gG" 250 A	1	gG	250
GSCL004/43	LV NHL KNIFE BLADE FUSE SIZE 1 CLASS "gG" 400 A	1	gG	400

For local components codification see Annex B.

## 5 REFERENCE LAWS AND STANDARDS

### 5.1 Laws

#### 5.1.1 LATAM

##### 5.1.1.1 Brazil

NR-10 – Segurança em instalações e serviços em eletricidade.

##### 5.1.1.2 Colombia

RETIE – Reglamento Técnico de Instalaciones Eléctricas.

##### 5.1.1.3 Peru

Código Nacional Electrico - Suministro.

### 5.1.2 Italy

D.Lgs n. 81 of the 9th of April 2008 and subsequent modifications.

D.P.R. n. 43 of the 27th of January 2012.

### 5.1.3 Spain

Real Decreto 337/2014, de 9 de mayo, por el que se aprueban el Reglamento sobre condiciones técnicas y garantías de seguridad en instalaciones eléctricas de alta tensión y sus Instrucciones Técnicas Complementarias ITC-RAT 01 a 23.

Real Decreto 842/2002, de 2 de agosto, por el que se aprueba el Reglamento electrotécnico para baja tensión.

Real Decreto 614/2001, de 8 de junio, sobre disposiciones mínimas para la protección de la salud y seguridad de los trabajadores frente al riesgo eléctrico.



	<b>GLOBAL STANDARD</b>	Page 9 of 39
	<b>LOW VOLTAGE FUSES (NH Knife Blade Fuse System)</b>	<b>GSC004 Rev. 0 23/11/2016</b>

## 5.2 Standards

### 5.2.1 Common standards

The below listed reference documents shall be intended in the in-force edition at the contract date (amendments included). Unless otherwise specified, these documents are valid until the new editions replace them.

For Latam the reference standards are the IEC/ISO, whilst for Europe the reference standards are the correspondent European ones (EN).

<b>IEC 60269-1</b>	Low-voltage fuses. Part 1: General requirements.
<b>IEC 60269-2</b>	Low-voltage fuses. Part 2: Supplementary requirements for fuses for use by authorized persons (fuses mainly for industrial application).
<b>ISO 216</b>	Writing paper and certain classes of printed matter -- Trimmed sizes -- A and B series, and indication of machine direction
<b>IEC 60529</b>	Degrees of protection provided by enclosures (IP Code)
<b>ISO 9001</b>	Quality management systems -- Requirements

### 5.2.2 Specific standards

Unless otherwise specified, these standards are valid until the new editions replace them.

#### 5.2.2.1 e-distribuzione (Italy)

Standards	Edition
CEI UNEL 06714-70	06-1976

#### 5.2.2.2 Latam

##### 5.2.2.2.1 Chilectra (Chile):

- NSEG 5. E.n.71 - Reglamento de Instalaciones Eléctricas de Corrientes Fuertes.
- NCH Elec. 4/2003 – Instalaciones de consumo en baja tensión

## 6 OPERATIONAL CONDITIONS

Where the following conditions apply, fuses complying with this standard are deemed capable of operating satisfactorily without further qualification. These conditions also apply for tests except those otherwise specified in Clause 12 of this standard.

	<b>GLOBAL STANDARD</b>	Page 10 of 39
	<b>LOW VOLTAGE FUSES (NH Knife Blade Fuse System)</b>	<b>GSC004 Rev. 0 23/11/2016</b>

### 6.1 Ambient air temperature ( $T_a$ )

The ambient air temperature  $T_a$  does not exceed 40 °C, its mean value measured over a period of 24 h does not exceed 35 °C, and its mean value measured over a period of one year is lower. The minimum value of the ambient air temperature is –5 °C.

Notes:

The time-current characteristics given are related to a reference ambient air temperature of 20 °C. These time-current characteristics also approximately apply to a temperature of 30 °C.

In cases where the temperature conditions vary significantly from these values, this should be taken into consideration from the points of view of operation, temperature rise, etc. See “Annex D” of standard IEC 60629-1.

### 6.2 Altitude

The altitude of the site of installation of the fuses does not exceed 2 000 m above sea-level.

### 6.3 Atmospheric conditions

The air is clean and its relative humidity does not exceed 50 % at the maximum temperature of 40 °C.

Higher relative humidity is permitted at lower temperatures, for example, 90 % at 20 °C.

Under these conditions, moderate condensation may occasionally occur due to variation in temperature.

NOTE : Where fuses are to be used under conditions different from those mentioned in 6.1, 6.2 y 6.3, in particular outdoors without protection, the manufacturer should be consulted. This applies also in cases where deposits of sea salt or abnormal deposits of industrial origin may occur.

### 6.4 Voltage

The system voltage has a maximum value not exceeding 110 % of the rated voltage of the fuse. For d.c. when obtained by rectifying a.c., the ripple shall not cause a variation of more than 5 % above or 9 % below the mean value of 110 % of the rated voltage.

For fuses rated 690 V the maximum system voltage shall not exceed 105 % of the rated voltage of the fuse.

Note: the indicating device or striker of a fuse may not operate if the fuse-link operates at a voltage considerably lower than its rated (see section 8.4.3.6 of Standard IEC 60269-1).

### 6.5 Discrimination of fuse-links

Limits of discrimination for times greater than 0,1s are given in **Tables 6 and 7** of this standard.

Pre-arcing  $I^2t$  values are given in **Tables 14 and 15** of this standard and operating  $I^2t$  values are given in the Standard IEC 60269-1. Values for other breaking ranges and utilization categories are shown in the Standard IEC 60269-1 too.

	GLOBAL STANDARD						Page 11 of 39					
	LOW VOLTAGE FUSES (NH Knife Blade Fuse System)						GSC004 Rev. 0 23/11/2016					

## 6.6 Specific operational conditions

Colombia (Codensa)

The altitude reference of the site of installation of the fuses will be 2.700 m above sea-level.

## 7 RATED CHARACTERISTICS

### 7.1 Rated Voltage

Is the voltage used to designate the fuse-base or the fuse-link and from which test conditions are specified.

The rated voltage for fuse-bases as well as for fuse-links is 500V a.c.

### 7.2 Rated current

#### 7.2.1 Rated current of the fuse-link

The values selected of rated current for every fuse size are indicated in **Table 2**

**Table 2 - Rated Current for every fuse size**

Size	Rated Current of the fuse-link (A)												
<b>00</b>	25	50	63	80	100	125	160						
<b>0</b>	40	<b>50</b>	<b>63</b>	<b>80</b>	<b>100</b>	<b>125</b>	160						
<b>1</b>	40		63	80	100	<b>125</b>	<b>160</b>	<b>200</b>	250		400*		
<b>2</b>		50	63	80	100	125	160	<b>200</b>	<b>250</b>	<b>315</b>	400		
<b>3</b>										<b>315</b>	<b>400</b>	<b>500</b>	<b>630</b>

Notes: the values marked in bold indicate fuse-links of preferential use.

The fuse-link with size "00" and rated current 400A corresponds to a NHL type. This fuse, as every fuse type NHL included in this standard, may be used only in Italy as a replacement device.

#### 7.2.2 Rated current of the fuse-holder

The rated current of the fuse-holder represents the highest rated current of the fuse-link with which it is intended to be used. The rated current of fuse-holders for NH fuses is indicated for each size in **Table 3**:

**Table 3 - Rated current for each size of the fuse-holder**

Size	Rated current of the fuse-holder (A)
00	160
0	160
1	250
2	400
3	630

### 7.3 Rated frequency

In the case of alternating current, the fuse must be compliant with the content of this standard for frequencies between 45 Hz and 62 Hz.

### 7.4 Rated power dissipation of a fuse-link and rated acceptable power dissipation of a fuse-holder

The maximum values of rated power dissipation of a fuse-link according to the different sizes are indicated in **Table 4**. Such values apply to the rated current of each fuse-link.

The values of rated acceptable power dissipation of a fuse-holder according to the different sizes are indicated in **Table 5**.

**Table 4 - Power dissipation for every fuse-link**

Size	00	0	1	2	3
<b>Rated Current (A)</b>	<b>Maximum power dissipation in fuse-link (W)</b>				
25	1,70				
40		4,95	4,75		
50	4,70	6,25		6,25	
63	5,75	7,70	7,35	7,55	
80	6,85	9,15	8,90	9,10	
100	8,15	10,90	10,60	10,70	
125	10,25	13,70	13,15	12,80	
160	12,00	16,00	15,50	15,70	
200			18,30	18,10	
250			23,00	24,00	
315				27,70	25,00
400			32,60	34,00	32,00
500					42,00
630					48,00

**Table 5 - Power dissipation for every fuse-holder**

Size	Rated current per phase (A)	Rated acceptable power dissipation of a fuse-holder (W)
00	160	12
0	160	25
1	250	32
2	400	45
3	630	60

## 7.5 Limits of time-current characteristics

The limits are based on a reference ambient air temperature  $T_a$  of +20°C.

### 7.5.1 Time-current characteristics, time-current zones

They depend on the design of the fuse-link, and, for a given fuse-link, on the ambient air temperature and the cooling conditions.

**Note:** For ambient air temperatures deviating from the temperature range according to section 6.1, consultation with the manufacturer is necessary.

When the time-current characteristics are presented, should be indicated for pre-arcing times exceeding 0,1 s, with current as abscissa and time as ordinate. Logarithmic scales shall be used on both coordinate axes.

The basis of the logarithmic scales (the dimensions of one decade) shall be in the ratio 2/1 with the longer dimensions on the abscissa. However, because of long-established practice in the United States of America, a ratio of 1/1 is recognized as an alternative standard. The presentation shall be made on standardized paper A3 or A4, according to ISO 216.

The dimensions of the decades shall be 2,8 cm in ordinate and 5,6 cm in abscissa.

Tolerance in time-current characteristics specified by the manufacturer must not exceed 10% with regard to current. The time-current zones specified in **Figures 1a** and **1b** must be respected, production tolerances included, in all the pre-arcing and operating times.

The manufacturer shall provide the time-current characteristics obtained by testing in accordance with Standard IEC 60269-1.

Time-current characteristics show the minimum pre-arcing time and the maximum operating time of the fuse-links. The resulting time-current zones shall ensure a discrimination with ratio 1,6 to 1 between rated currents.

### 7.5.2 Conventional times and currents

Conventional times and currents are specified in **Table 6**.

**Table 6 - Conventional times and currents for “gG” fuse-links**

Rated current $I_n$ for gG (A)	Conventional time (h)	Conventional current	
		$I_{nf}$	$I_f$
$16 \leq I_n \leq 63$	1	1,25 $I_n$	1,6 $I_n$
$63 \leq I_n \leq 160$	2		
$160 \leq I_n \leq 400$	3		
$400 \leq I_n$	4		

Time-current characteristics are shown in **Figures 1a** and **1b**.

### 7.5.3 Gates

For "gG" fuse-links, the gates given in **Table 7** apply.

**Table 7 - Currents Vs specified pre-arcing time for “gG” fuse-links**

$I_n$ for gG (A)	$I_{min. (10 s)^1}$ (A)	$I_{max. (5 s)}$ (A)	$I_{min. (0,1 s)}$ (A)	$I_{max. (0,1 s)}$ (A)
25	52	110	150	260
40	95	190	260	450
50	125	250	350	610
63	160	320	450	820
80	215	425	610	1100
100	290	580	820	1450
125	355	715	1100	1910
160	460	950	1450	2590
200	610	1250	1910	3420
250	750	1650	2590	4500
315	1050	2200	3420	6000
400	1420	2840	4500	8060
500	1780	3800	6000	10600
630	2200	5100	8060	14140

$I_{min (10 s)}$  is the minimum value of current for which the pre-arcing time is not less than 10 s.

### 7.5.4 Breaking range and utilization category

The first letter shall indicate the breaking range:

- “g” fuse-links (full-range breaking-capacity fuse-link).

The second letter shall indicate the utilization category; this letter defines with accuracy the time-current characteristics, conventional times and currents, gates.

	<b>GLOBAL STANDARD</b>	Page 15 of 39
	<b>LOW VOLTAGE FUSES (NH Knife Blade Fuse System)</b>	<b>GSCl004</b> Rev. 0 23/11/2016

- “gG” indicates fuse-links with a full-range breaking capacity for general application.

Note: In this standard only “gG” fuse-links are considered.

### **7.5.5 Rated breaking capacity**

The manufacturer according to the rated voltage gives the rated breaking capacity of a fuse-link. Fuse-links subject to the present standard shall have a minimum rated breaking capacity of 50 kA.

Figure 1a - Time-current zones for "gG" fuse-links (Continues)

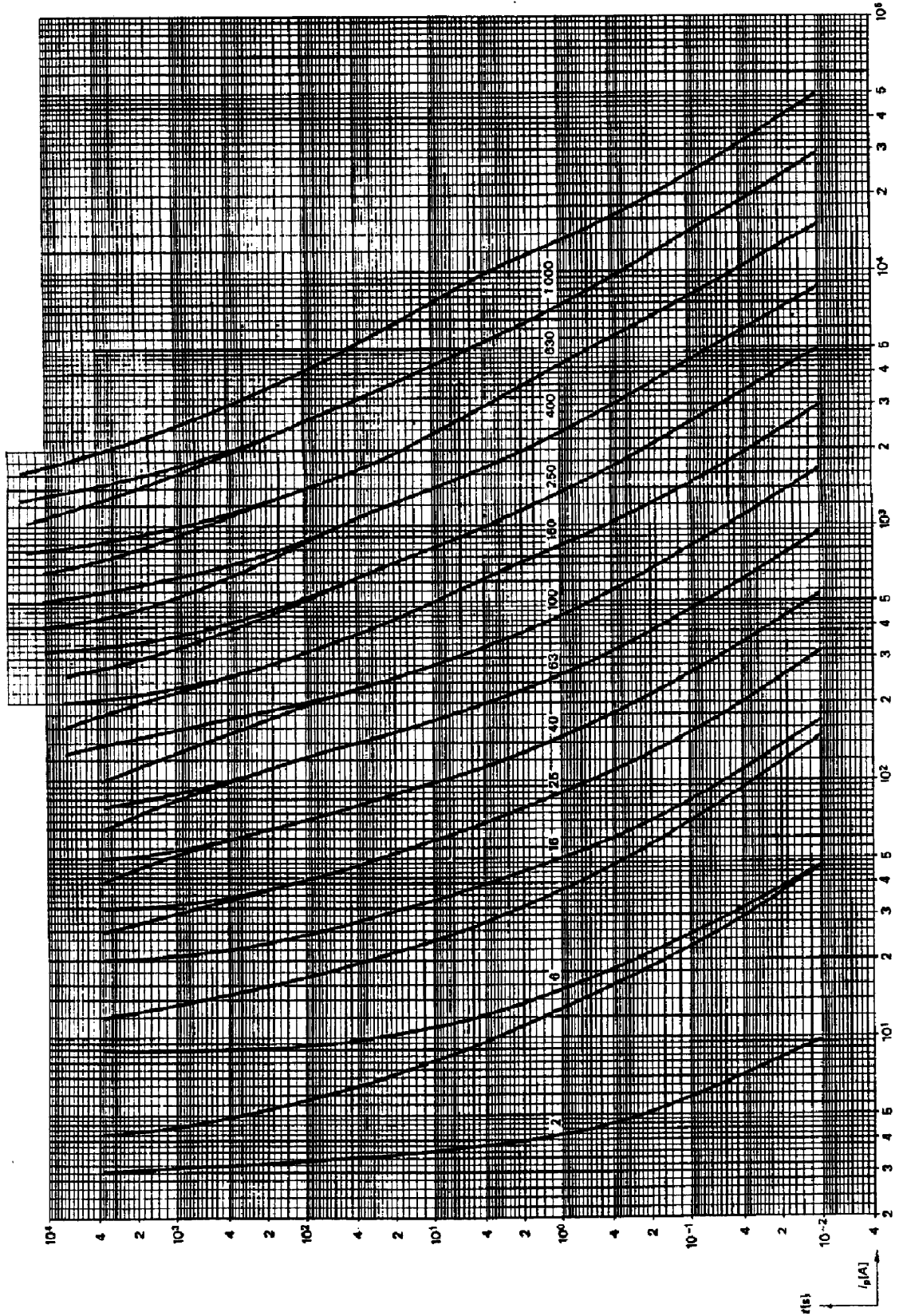
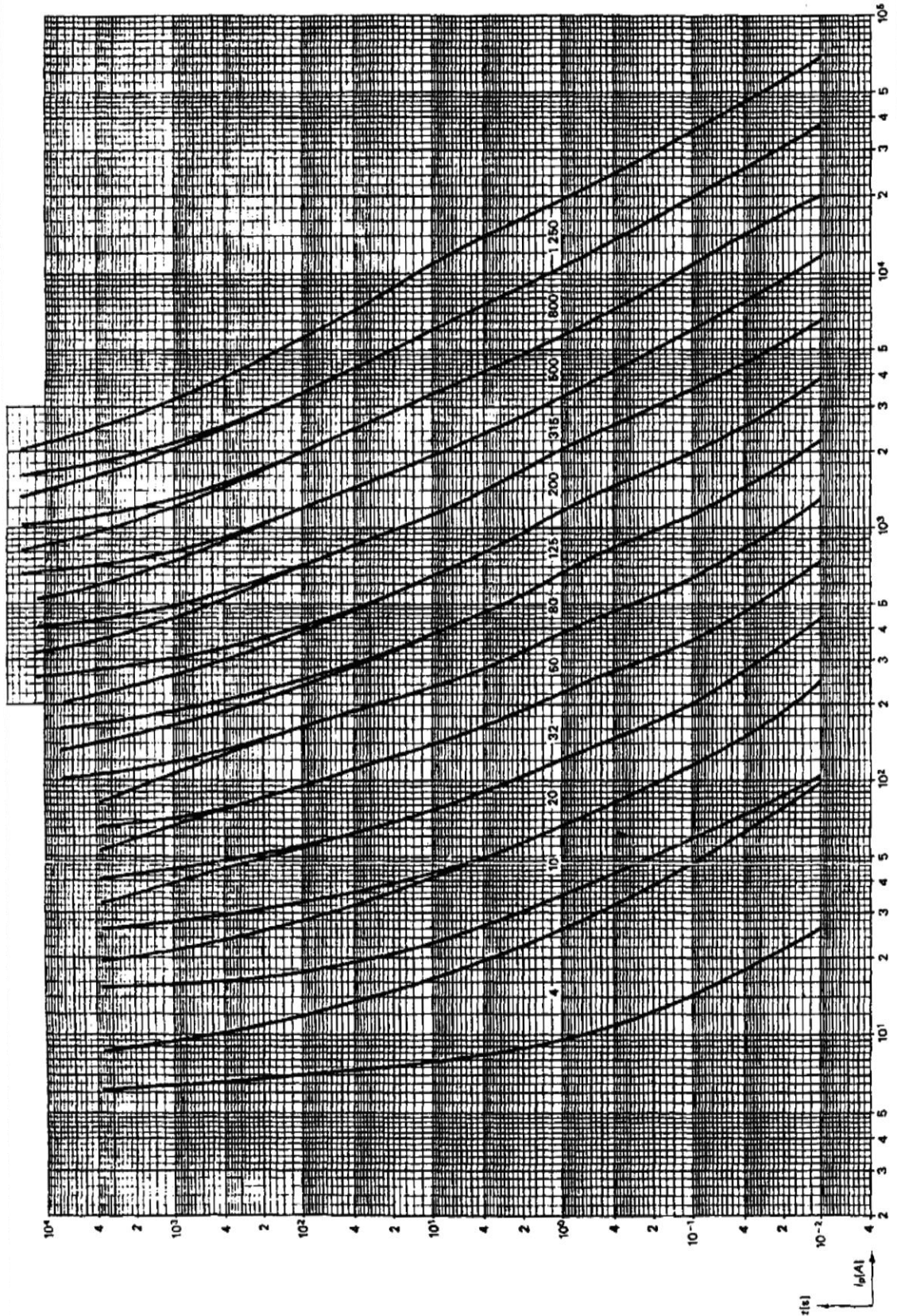



Figure 1b - Time-current zones for “gG” fuse-links (End)



### 7.6 Cut-off current and $I^2t$ characteristics

The values for cut-off and  $I^2t$  characteristics shall take into account manufacturing tolerances and shall refer to the specified service conditions, for example, the values of voltage, frequency and power factor.

## 8 Conditions for construction

### 8.1 Mechanical design for NH type fuses

The dimension drawings of fuse-links, fuse-bases and fuse handles are shown in Figures 2, 3 and 4 of this standard.

The drawings do not impose a specific model of fuse-link, fuse-base or fuse handle, except for the notes and measures indicated.

**Figure 2 – Knife blade fuse-link (NH type)**

(measures in mm)

Legend:

- A Indicating device (indicator), (see note 8)
- B Fuse-contact
- C Closing plate
- D Mechanical stop
- E Detail Y (sectional view)
- F Rounded edge, (see note 13)
- G Contact face

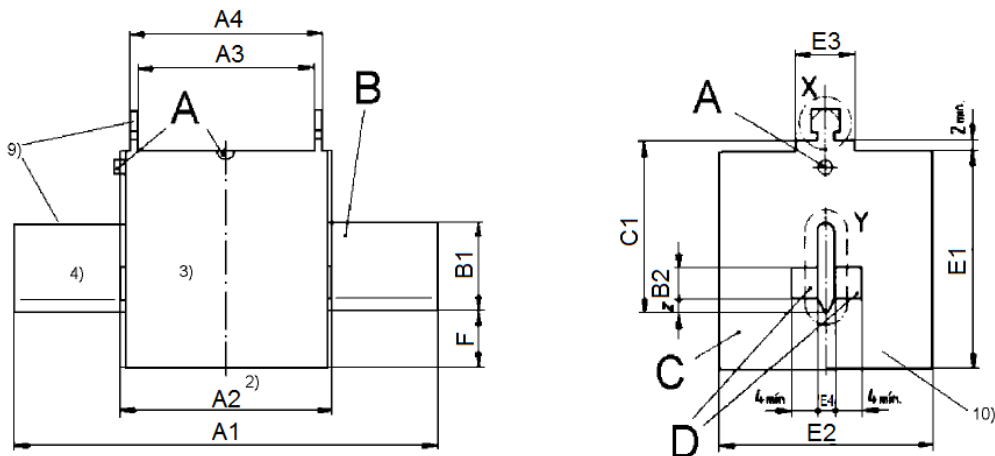

5)

Detail X

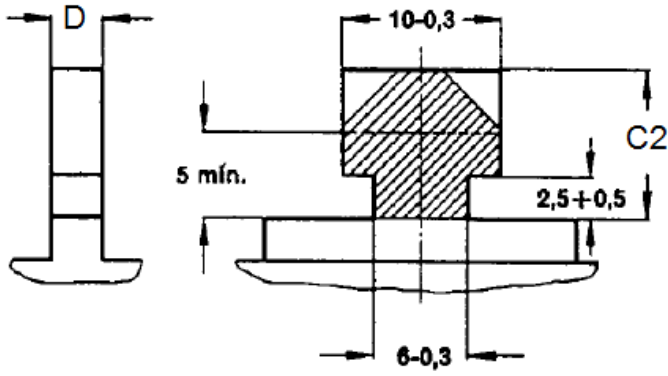

Detail Y

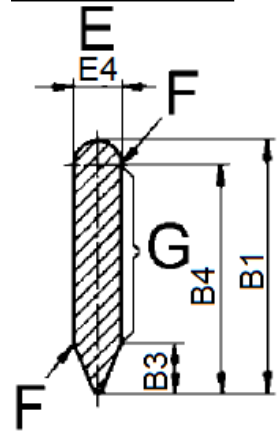



	<b>GLOBAL STANDARD</b>	Page 20 of 39
	<b>LOW VOLTAGE FUSES (NH Knife Blade Fuse System)</b>	<b>GSC004 Rev. 0 23/11/2016</b>

**Tables 8a and 8b – Dimensions of knife blade fuse-links (NH Type)**

(measures in mm)

Size	A1 (1)	A2 (2)	A3 (1)	A4 (1)	B1(min) (12)	C1 ± 0,8	C2	D (5)
00	78,5 ± 1,5	54 (+0, -6)	45 ± 1,5	49 ± 1,5	15	35	10 (+0, -1)	2 (+1,5, -0,5)
0	125 ± 2,5	68 (+0, -8)	62 (+3, -1,5)	68 (+1,5, -3)	15	35	11 (+0, -2)	2 (+1,5, -0,5)
1	135 ± 2,5	75 (+0, -10)	62 ± 2,5	68 ± 2,5	20	40	11 (+0, -2)	2,5 (+1,5, -0,5)
2	150 ± 2,5	75 (+0, -10)	62 ± 2,5	68 ± 2,5	25	48	11 (+0, -2)	2,5 (+1,5, -0,5)
3	150 ± 2,5	75 (+0, -10)	62 ± 2,5	68 ± 2,5	32	60	11 (+0, -2)	2,5 (+1,5, -0,5)

Size	E1 (max) (6)	E2(max) (6)	E3	E4± 0,2	F (max)
00	48	30	20 ± 5	6	15
0	48	40	20 ± 5	6	15
1	53	52	20 (+5, -2)	6	15
2	61	60	20 (+5, -2)	6	15
3	76	75	20 (+5, -2)	6	18

Notes:

- 1) The centers of the dimensions a1, a3 and a4 should not differ by more than 1,5 mm from the center of a2.
- 2) The dimension a2 must be respected in all the zone of the mechanical stops (b2 X 4 min.) on both sides of the blades. Outside these areas the maximum dimension a2 is applied
- 3) Insulating material
- 4) The blades must be aligned along the same axis and the contact surfaces should be flat.
- 5) Fitting for the fuse handles (detail X)
- 6) (6) Maximum size of fuse-link enclosure. Within this envelope the fuse-links can adopt any shape, such as: square, rectangular, round, oval, polygonal, etc.
- 7) Without content
- 8) Indicating device. Its location is left at the choice of the manufacturer.
- 9) Live parts. The pins for fuse-handles fitting can be insulated
- 10) Except for the fuse-handles fittings (detail X), the endplates should not protrude from the insulated body.
- 11) Without content
- 12) If the rated currents overlap partially in the sizes 0, 1, 2 y 3, it will be acceptable the dimension of the smaller size.
- 13) All the edges should be rounded in order not to damage the contact surface of the fuse-base.

Figure 3 – Fuse-bases for knife blade fuse-links (NH type)  
(measures in mm)

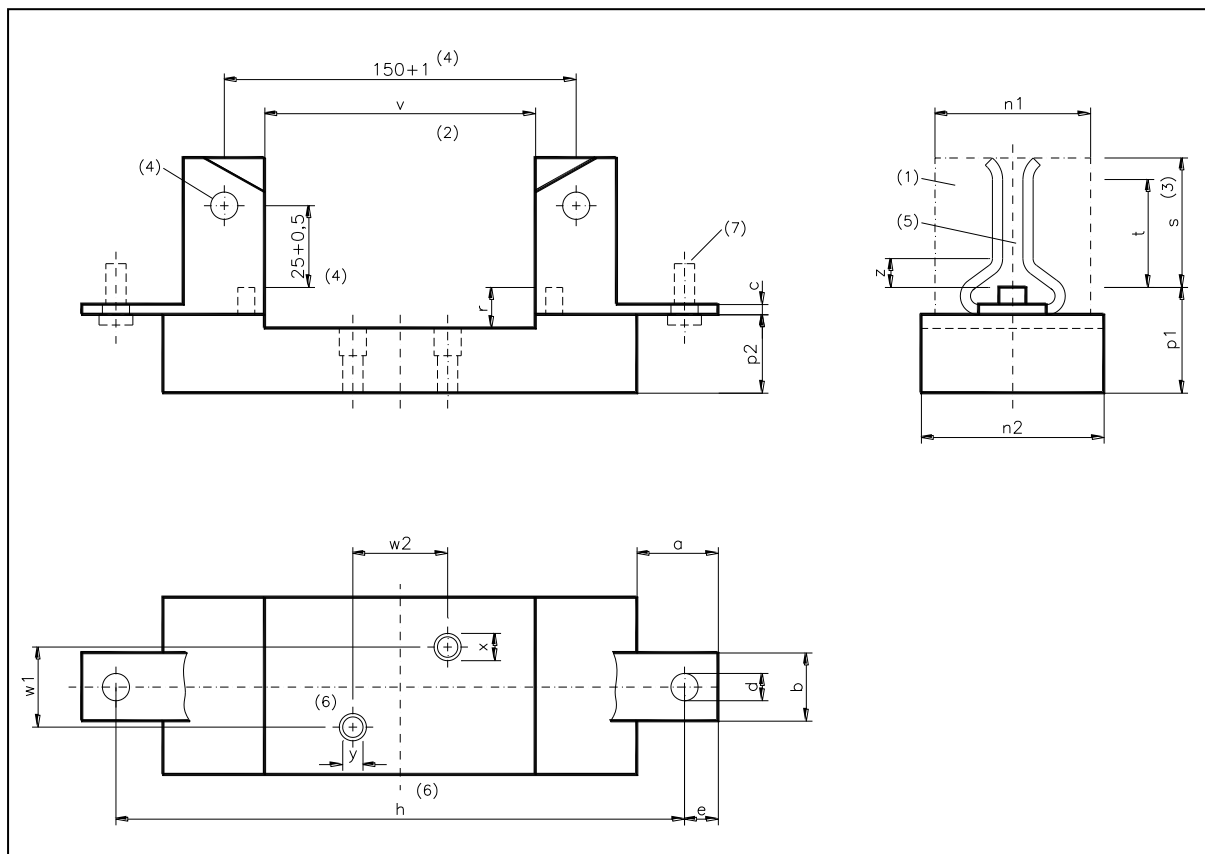

Tables 9a and 9b – Dimensions of fuse-bases for knife blade fuse-links (NH Type)  
(measures in mm)

Size	$h \pm 1,5$ (6)	$n_1$ (max)	$n_2$ (max)	$p_1$ (max)	$p_2 \pm 1,5$	$r$ (min)	$s$ (3) (max)	$t$ (min)
00	100	30	38	40	---	17	21	15
0 (8)	150	40	48	48	---	17	25	15
1	175	52	60	55	35	17	38	21
2	200	60	68	60	35	17	46	27
3	210	75	83	68	35	20	58	33

Size	$v$	$w_1$ (6)	$w_2$ (6)	$x$ (min) (6)	$y \pm 0,5$ (6)	$z$ (max)
00	$56,5 \pm 1,5$	$0 \pm 0,7$	$25 \pm 0,7$	14	7,5	3
0 (8)	$74 \pm 3$	$0 \pm 0,7$	$25 \pm 0,7$	14	7,5	3
1	$80 \pm 3$	$30 \pm 0,7$	$25 \pm 0,7$	20	10,5	5
2	$80 \pm 3$	$30 \pm 0,7$	$25 \pm 0,7$	20	10,5	5
3	$80 \pm 3$	$30 \pm 0,7$	$25 \pm 0,7$	20	10,5	5

	<b>GLOBAL STANDARD</b>	Page 22 of 39
	<b>LOW VOLTAGE FUSES (NH Knife Blade Fuse System)</b>	<b>GSC004 Rev. 0 23/11/2016</b>

Notes :

- 1) This is a live area.
- 2) The maximum value for the dimension “v” aims to define a contact point. It shall be respected at least for a contact point inside the two areas “b2 x 4min.” of the fuse-link. The dimensión “v” can Debe respetarse al menos para un punto de contacto en el interior de las dos áreas b2 X 4 min. del cartucho fusible. The dimension “v” can also be achieved by means of insulated covers in the contact.
- 3) Height of the contact surface. It should also be possible to introduce knife blade fuse-links indicated in the Figure 2, even if the contact surface isn’t smooth but fluted or split.
- 4) Without content
- 5) Lira-type base for 1, 2 and 3 sizes. Contact force provided by auxiliary means (Contact surface with springs).
- 6) This values are only mandatory if interchangeability is required.
- 7) Inserted screw, fixed by appropriate means, to prevent movement when the torque specified in Table 12 is applied.
- 8) Not allowed in new installations except for fuse-links with striker.

**Table 9c – Dimensions of fuse-bases for knife blade fuse-links (NH Type)**

(measures in mm)

Size	a (1) (5) min.	b (1) min.	c (4) min.	d ± 0,25		e ± 0,5
				Through hole	Thread (6)	
00	20	20	3	9	M8	10
0 (7)	23	20	3	9	M8	10
1	24	25	4	11	M10	12,5
2	28	25	4	11 (2)	M 10 (2)	12,5
3	35	30	5	11 (2)	M 10 (2)	15

Notes:

- 1) Depending on the construction features larger dimensions “a” and “b” are allowed or different shapes, for example rounded or circular, whenever the dimensions “d” and “e” are maintained.
- 2) M12 is allowed with 14 mm through-hole
- 3) Without content
- 4) The dimension “c” can be lower whenever mechanical stress generated connecting the conductors is supported without deformation in the connection. Those types with threads should comply the requirements regarding the torque.
- 5) The dimension “a” should be measured in the upper part of the connection.
- 6) The thread of the inserted screw will be as indicated in Table 12.
- 7) Not allowed in new installations except for fuse-links with striker.

Figure 4 - Fuse handles  
(measures in mm)

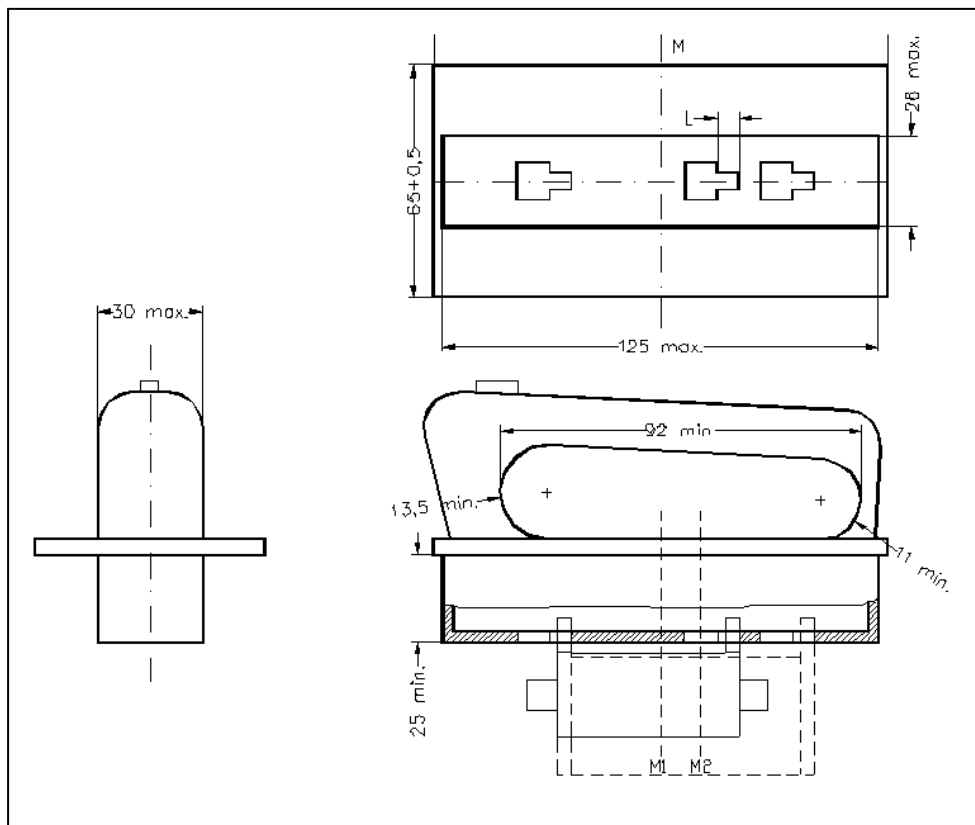

Table 10 – Dimensions of fuse handles

Size	L (mm)	Distance	
		M-M1 (mm)	M-M2 (mm)
00	14	0 ± 3	--
0...3	16	--	11 ± 3

Notes:

- M1 for size 00
- M2 for sizes 0...3
- M: Center of the coupling
- L: Allowable space for introduction and extraction of fuse-links

	<b>GLOBAL STANDARD</b>	Page 24 of 39
	<b>LOW VOLTAGE FUSES (NH Knife Blade Fuse System)</b>	<b>GSC004 Rev. 0 23/11/2016</b>

### 8.1.1 Connections, included terminals

Fixed connections shall be made to ensure the necessary contact force in operation and service conditions.

The contact force applied on the connections must not be transmitted by means of insulated materials different to ceramics or others with the same properties, unless that the metallic parts will be elastic enough as for to compensate a possible contraction or any other deformation of the insulated material

Terminals must be designed in such a way that cannot turn or displaced as a consequence of tightening of screws and in such a way that conductors position cannot be modified. The parts gripping the conductors must be made in metal and must have a shape as for not damage the conductors.

Terminals must be arranged to have an easy access (after covers removal, if any) in the conditions prescribed of installations.

There are different types of terminals for fuse-base. In those provided for connection with conductors ending in terminals, the range of sections that must be supported is consequence of the range of rated currents indicated for each size of fuse-link.

Terminals of fuse-base designed for connection with unterminated conductors must be compatible with, at least, three consecutive sizes of conductors as indicated in the sections ranges indicated in **Table 11**.

In case of fuse-bases provided for connection with conductors ending in terminals, the prescribed torque to be applied is shown in **Table 12**. The values of prescribed torque concerning to other typologies of fuse-base connection must be indicated in the manufacturer instructions.

**Table 11 - Range of unterminated conductors sections.**

Size	Range of rated currents of fuse-links ( A )	Conductor sections. mm <sup>2</sup>
		Aluminum
00	25 a 160	25 a 95
0	40 a 160	25 a 95
1	63 a 400	95 a 150
2	80 a 400	120 a 240
3	315 a 630	

Higher or lower connections can be necessary. They can achieved either by construction of the fuse-base terminal or with additional connection means recommended by the manufacturer.

**Table 12 - Torque to apply at the terminal screws**

In (A)	Size of fuse-base	Screw size	Torque (Nm)
160	00	M8	10
160	0	M8	10
250	1	M10	32
400	2	M10	32
630	3	M10/M12	32/56



	<b>GLOBAL STANDARD</b>	Page 25 of 39
	<b>LOW VOLTAGE FUSES (NH Knife Blade Fuse System)</b>	<b>GSCl004 Rev. 0 23/11/2016</b>

### 8.1.2 Fuse contacts

Fuse contacts must be made in such a way as to maintain the necessary contact force in conditions of service and operation, particularly in the conditions corresponding to section 7.5 of standard IEC 60269-1.

The contact must be such that electromagnetic forces produced during operation, under the conditions defined at section 7.5 of standard IEC 60269-1, do not damage the electrical connection between:

- a) the fuse-base and the fuse carrier
- b) the fuse carrier and the fuse-link
- c) the fuse-link and the fuse base, or, where applicable, in any other support.

In addition, because of its construction and material used, the contacts must be such that, with an appropriate assembly of the fuse and in normal operation conditions, the maintenance of a proper contact is ensured:

- a) after repeated removal and insertion operations
- b) after maintaining in service, with no intervention, for a long time (see section 8.10 de standard IEC 60269-1).

Fuse-contacts of copper alloy shall be free from season cracking.

Contact surface of fuse-links and fuse-bases must be silver-plated or tinned. Compliance with the required conditions for the fuse-contacts will be verified by the tests indicated at section 8.10 and 8.11.2.1 of the standard IEC 60269-1, and at section 8 of this standard.

### 8.1.3 Construction of fuse-link

Fuse-links must be manufactured with its blades in solid material.

Excepting for the fuse-handles coupling, the end plates should not protrude radially from the insulating body. For certain applications it's preferable to insulate the fuse-handles fixing points from the live parts.

Fuse-links should incorporate an indicating device. The conductive parts of indicating devices must not be expelled from the fuse-link during operation.

## 8.2 Mechanical design of fuses NH L type.

The fuses listed in Table 1 with codes between GSCl004/36 and GSCl004/43 must be compliant with the following figure 5:

Fig. 5 – Knife-blade fuse link (NH L type)  
(dimensions mm)

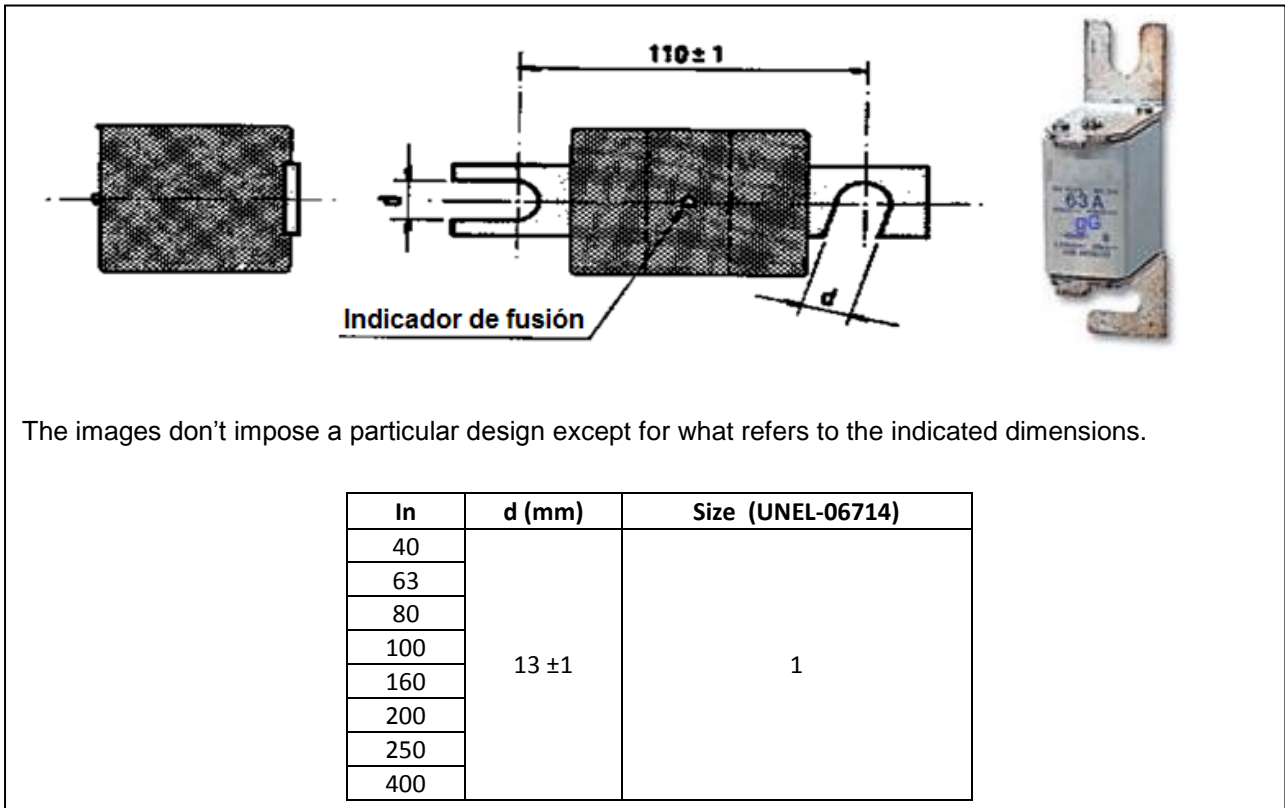

The fuses NH L type indicated above can be used exclusively in Italy and only for replacement. For new installations the existing LV cabinets shall be replaced by LV cabinets standardized in Italy according the DY3009, incorporating circuit breakers instead of fuses. All the other technical characteristics for fuses NH L type will be the same that those indicated for fuses NH type in section 8.1

### 8.3 Insulating properties omega

The fuses must not lose their insulating properties at the voltages to which they are subjected in normal operation. It will be considered that a fuse meet this criteria if it passes the test "Verification of the insulating properties" indicated in section 8.2 of standard IEC 60269.1

### 8.4 Temperature rise, power dissipation of the fuse-link and acceptable power dissipation of a fuse-holder

The fuse-holder, which will be lyre or omega type, must be designed and dimensioned as to support continuously, under normal operating conditions, the rated current of the fuse-link with which it is provided, without exceeding the maximum values of temperature rise indicated in **Table 13** at the rated acceptable power dissipation of the fuse-holder

In particular, temperature-rise limits specified in **Table 13** must not be exceeded when:

- the rated current of the fuse-link is equal to the rated current of the fuse holder intended to accommodate this fuse-link.

	<b>GLOBAL STANDARD</b>	Page 27 of 39
	<b>LOW VOLTAGE FUSES (NH Knife Blade Fuse System)</b>	<b>GSCLO04 Rev. 0 23/11/2016</b>

- the power dissipation of the fuse-link is equal to the rated acceptable power dissipation of the fuse holder intended to accommodate this fuse-link.

These requirements are checked by tests carried out in compliance with section 8.3 of the standard IEC 60269-1.

**Table 13 - Temperature-rise limits  $\Delta T = (T - T_a)$  for contacts and terminals**

Contacts <sup>7) 9)</sup>		Temperature-rise °K	
Shape	Nature of the material	Unenclosed <sup>1)</sup>	Enclosed <sup>2)</sup>
Spring loaded	Bare copper	40	45
	Bare brass	45	50
	Tin plated	55 <sup>6)</sup>	60 <sup>6)</sup>
	Nickel-plated <sup>10)</sup>	70 <sup>5) 3) 8)</sup>	75 <sup>5) 3) 8)</sup>
	Silver-plated	3)	3)
Bolted	Bare copper	55	60
	Bare brass	60	65
	Tin plated	65 <sup>6)</sup>	65 <sup>6)</sup>
	Nickel-plated <sup>10)</sup>	80 <sup>5) 3) 8)</sup>	85 <sup>5) 3) 8)</sup>
	Silver-plated	3)	3)
Terminals	Bare copper	55	60
	Bare brass	60	65
	Tin plated	65 <sup>3)</sup>	65 <sup>3)</sup>
	Nickel-plated or Silver-plated	70 <sup>4)</sup>	70 <sup>4)</sup>

Notes:

- 1) For  $T_e = T_a$  (see section 2.2.5 of standard IEC 60269-1)
- 2) Applicable for values of  $\Delta T_e$  between 10 K and 30 K ( $10 \text{ K} \leq \Delta T_e \leq 30 \text{ K}$ ), the ambient air temperature  $T_a$  should not be higher than 40° C.
- 3) Limited only by the necessity of not causing any damage to adjacent parts.
- 4) The limit of temperature rise is governed by the use of PVC insulated conductors.
- 5) The given values do not apply for fuse systems for which the cross-sectional area and the material of the contacts are given in the subsequent parts.
- 6) These limits may be exceeded if it is verified that no deterioration of the contact is caused by the actual temperature during the test for non-deterioration of contact.
- 7) The values do not apply to certain fuses which are too small, so the temperature cannot be measured without the risk of failure. Therefore, the verification of non-deterioration of contacts will be done by a test given in section 8.10 of standard IEC 60269-1.
- 8) The use of nickel-plated contacts requires, due to its relatively high electrical resistance, certain precautions in the design of the contact, among others the use of a relatively high contact pressure.
- 9) The test for non-deterioration of contacts is given in section 8.10 of standard IEC 60269-1
- 10) DO NOT USE

	<b>GLOBAL STANDARD</b>	Page 28 of 39
	<b>LOW VOLTAGE FUSES (NH Knife Blade Fuse System)</b>	<b>GSC004</b> <b>Rev. 0</b> <b>23/11/2016</b>

## 8.5 Operation

The fuse-link must be designed and dimensioned in such a way that, when is tested in the proper testing arrangement at rated frequency and at ambient air temperature of  $20 \pm 5^\circ\text{C}$ :

- it is able to withstand continuously whatever current less than or equal to its rated current.
- it is able to withstand overload conditions as they can occur in normal service (see section 8.4.3.4 of standard IEC 60269-1)

For a “g” fuse-link, this mean:

- that its fuse element does not melt in less than the conventional time when it carries a current less than or equal to the conventional non-fusing current ( $I_{nf}$ );
- that it operates in less than the conventional time when it carries a current equal to or exceeding the conventional fusing current ( $I_f$ ).

NOTE : Time-current zones should be considered

The time-current values measured according the section 8.4.3.3 of the standard IEC 60269-1, must be located inside the time-current zone indicated by the manufacturer.

This conditions are considered as fulfilled if the fuse-link passes the tests indicated in section 8.4 of standard IEC 60269-1

## 8.6 Cut-off current characteristics and $I^2t$ characteristics

The  $I^2t$  pre-arcing values, verified according section 8.7 of standard IEC 60269-1, must not be less than the characteristics indicated by the manufacturer, as stated in section 5.8.2 of the aforementioned standard IEC 60269-1, and must be inside the limits shown in **Table 14**.

In the fuse-links object of this standard, the maximum  $I^2t$  pre-arcing values indicated in **Table 14** are, at the same time, the maximum  $I^2t$  values of operation.

**Table 14 -  $I^2t$  pre-arcing values at 0,01 s for fuse-links “gG”**

$I_n$ for gG ( A )	$I^2t$ min. $10^3 \times ( A^2 s )$	$I^2t$ max. $10^3 \times ( A^2 s )$
25	1,0	3,0
40	3,0	9,0
50	5,0	16,0
63	9,0	27,0
80	16,0	46,0
100	27,0	86,0
125	46,0	140,0
160	86,0	250,0
200	140,0	400,0
250	250,0	760,0
315	400,0	1300,0
400	760,0	2250,0
500	1300,0	3800,0
630	2250,0	7500,0

### 8.7 Overcurrent discrimination of fuse-links “gG” type.

Requirements concerning overcurrent discrimination are dependant upon the rated voltage and the application of the fuse.

Serially manufactured fuse-links whose ratio of rated current is 1:1,6 should be able to operate selectively up to the values specified in section 8.7.4 of standard IEC 60269-1

For overcurrent discrimination when circuit breakers are used, the values indicated in **Table 15** must be respected.

**Table 15 - Pre-arcing I<sup>2</sup>t values for overcurrent discrimination**

I <sub>n</sub> A	I <sup>2</sup> t A <sup>2</sup> s	for I <sub>p</sub> A
25	810	900
40	2.500	1.580
50	4.000	2.000
63	6.300	2.510
80	10.000	3.160
100	16.000	4.000
125	24.000	4.900
160	42.500	6.520
200	78.000	8.830

### 8.8 Protection against electric shock

For the protection of persons against electric shock, three states of the fuse must be considered:

- When the fuse is complete , installed and connected, in other words, when it's equipped with fuse-base, fuse-link and, where applicable, fuse-carrier, fuse-gauge and enclosure forming part of the fuse (normal service condition).
- When replacing the fuse-link.
- When the fuse-link is removed and, where necessary, the fuse-holder.

The corresponding requirements are specified in subsequent parts. See also section 8.8 of standard IEC 60269-1.

The protection against electric shock can be increased by means of dividers or covers for the fuse-link contacts.

### 8.9 Resistance to heat

All components must be sufficiently resistant to heat that may occur in normal use.

This condition is considered as fulfilled if the fuse passes the tests indicated in sections 8.9 and 8.10 of standard IEC 60269-1.

	<b>GLOBAL STANDARD</b>	Page 30 of 39
	<b>LOW VOLTAGE FUSES (NH Knife Blade Fuse System)</b>	<b>GSC004 Rev. 0 23/11/2016</b>

### **8.10 Mechanical strength**

All components of the fuse must be sufficiently resistant to mechanical stresses that may occur in normal use.

This condition is considered as fulfilled if the fuse passes the tests indicated in sections 8.3, 8.4 and 8.5 of standard IEC 60269-1.

### **8.11 Resistance to corrosion**

All metallic components of the fuse must be resistant against corrosive influences that may occur in normal use.

#### **8.11.1 Resistance to rusting**

All ferrous components of the fuse must be protected so as to satisfy the corresponding tests.

This condition is considered as fulfilled if the fuse passes the tests indicated in sections 8.2.4.2 and 8.11.2.3 of standard IEC 60269-1.

#### **8.11.2 Resistance to season cracking**

All current-carrying parts must offer sufficient resistance to season cracking.

This condition is considered as fulfilled if the fuse passes the tests indicated in sections 8.2.4.2 and 8.11.2.1 of standard IEC 60269-1.

### **8.12 Resistance to abnormal heat and fire**

All fuse components must offer sufficient resistance to abnormal heat and fire.

This condition is considered as fulfilled if the fuse passes the test indicated in section 8.11.2.2 of standard IEC 60269-1.

## **9 Markings**

Marking must be indelible and easily legible.

### **9.1 Marking of fuse-holders**

The fuse holders must incorporate marking with the following information:

- Manufacturer name or trademark by which he can be easily identified.
- Manufacturer's identification reference that allows to find all the characteristics indicated in section 5.1.1 of standard IEC 60269-1.

	<b>GLOBAL STANDARD</b>	Page 31 of 39
	<b>LOW VOLTAGE FUSES (NH Knife Blade Fuse System)</b>	<b>GSCl004 Rev. 0 23/11/2016</b>

- Rated voltage.
- Rated current.
- Kind of current and rated frequency, if necessary.
- Year of manufacture.

Notes:

The marking of rated current and rated voltage must be easily distinguished from the front side when the fuse-holder is not equipped with a fuse-link.

If a fuse-holder contains a removable fuse-base and a removable fuse-carrier, both must be marked separately for identification reasons.

## 9.2 Marking of fuse-links

The fuse- links, except those of small size in which marking is physically impossible, should incorporate marked the following information:

- Manufacturer name or trademark by which he can be easily identified.
- Manufacturer's identification reference that allows to find all the characteristics indicated in section 5.1.2 of standard IEC 60269-1.
- Rated voltage (V).
- Rated current (A).
- Minimum breaking capacity (A).
- Breaking range and utilization category (letter code) if necessary (see 7.5.4)
- Kind of current and rated frequency, if necessary (see 7.3).
- Rated power dissipation.
- Year of manufacture.

Note: The marking of rated current and rated voltage must be easily distinguished from the front side.

## 9.3 Designation

### 9.3.1 Designation of fuse-bases

The fuse-bases will be designated with the following alphanumeric code: **B CU<sub>x</sub>**, where:

<b>B</b>	Base
<b>CU00</b>	Knife-blade type of size 00
<b>CU0</b>	Knife-blade type of size 0
<b>CU1</b>	Knife-blade type of size 1
<b>CU2</b>	Knife-blade type of size 2
<b>CU3</b>	Knife-blade type of size 3

	<b>GLOBAL STANDARD</b>	Page 32 of 39
	<b>LOW VOLTAGE FUSES (NH Knife Blade Fuse System)</b>	<b>GSC004 Rev. 0 23/11/2016</b>

Example : Fuse-base knife-blade type of size 1: B CU1

### 9.3.2 Designation of fuse-links

The fuse-links will be designated with the following alphanumeric code: **F CUx/I(A)**, where:

<b>F</b>	Fuse-link
<b>CU00</b>	Knife-blade type of size 00
<b>CU0</b>	Knife-blade type of size 0
<b>CU1</b>	Knife-blade type of size 1
<b>CU2</b>	Knife-blade type of size 2
<b>CU3</b>	Knife-blade type of size 3
<b>I(A)</b>	Value of rated current, in Amperes

Exemple: 250A fuse-link knife-blade type of size 2: F CU2/250

## 10 PACKAGING

On the outside of each fuse box, it must be clearly stated:

- Name of the power distribution company (for example: Endesa Distribución Eléctrica)
- Name of the supplier.
- Product description.
- Code assigned by the supplier.
- Global Standard reference and material code assigned by the power distribution company to which is addressed.
- Gross weight.

## 11 EXCEPTIONS TO THIS SPECIFICATION

Any exception to this technical specification, concerning the adoption of techniques and/or special construction different than what is specified in this document, may be taken into account during the homologation process. However, in this case, the Distribution Company reserves the right to prescribe the execution of additional tests other than those ones described in this document, in relation to the specific proposals.

## 12 TESTING

The tests will be carried out according to that described in the following paragraphs. Unless stated otherwise, all references are taken from the standards IEC 60269-1 and IEC 60269-2.



	<b>GLOBAL STANDARD</b>	Page 33 of 39
	<b>LOW VOLTAGE FUSES (NH Knife Blade Fuse System)</b>	<b>GSC004</b> <b>Rev. 0</b> <b>23/11/2016</b>

## 12.1 General

The tests specified in this section are type tests and will be carried out under the manufacturer's responsibility.

If there is a failure during testing and the manufacturer can prove that this failure is not inherent to the type of fuse, but due to an individual fault of the tested specimen, the corresponding test must be repeated. This does not apply to testing of "Verification of the breaking capacity".

The acceptance tests are those listed in **Table 19**.

Type tests are performed in order to verify that a particular type of fuse or a range of fuses forming a homogeneous series (see section 8.1.5.2 of the standard IEC 60269-1) corresponds to the specified characteristics, and operates satisfactorily under normal conditions of service or under particular specified conditions.

If a fuse satisfies the type tests, all the fuses of identical construction meet the requirements of this standard.

Type tests should be repeated if any part of the fuse is changed in such a way that the results of the tests already carried out may be affected.

The ambient air temperature ( $T_a$ ) should be measured by measuring devices protected against airflows and any heat radiation, placed at half height of the fuse and at a distance of about 1 meter. At the beginning of each test, the fuse should be approximately at the ambient air temperature.

The tests should be carried out on clean and dry fuses.

Except for the degree of protection test (see section 8.8 of standard IEC 60269-1), the fuse must be mounted in free air, in an area without airflows, in normal operating position, for example vertically, and unless otherwise specified, on a support of insulating material with sufficient rigidity so as to withstand the stress that may occur in the absence of any external forces on the fuse under test.

The fuse-link should be mounted either as in normal use, or in the fuse holder for which it is intended, or in a test rig in accordance with the indications given in the subsequent parts.

Before the tests are started, the specified external dimensions should be measured and the results should be compared with the dimensions shown in the particular data sheets of the manufacturer or specified in subsequent parts.

Unless otherwise specified in the subsequent parts, the fuse-links should be tested with the provided kind(s) of current and, for alternating current, at the frequency for which they are designed.

Before the tests are started, the internal resistance  $R$  is measured in all samples at an ambient air temperature of  $20^\circ\text{C} \pm 5^\circ\text{C}$  with a measuring current not exceeding  $0,1 I_n$ . The value of  $R$  should be included in the test report.

The tests list is shown in **Tables 16 , 17 y 18**.

## 12.2 Type-approval tests

To obtain type-approval, the fuses must pass successfully the tests listed in tables 16 and 17. These tests should be carried out in an official and independent accredited laboratory.

Unless otherwise specified, the sections and tables indicated in Tables 16 and 17 make reference to standard IEC 60269-1.

**Table 16 - Type-approval tests for fuse-links**

Test	Number of samples	Method and conditions	Values to obtain and requirements
Marking	The number of fuse-links to be tested as well as their rated currents, are indicated in the standard IEC 60269-1	Visual examination	Section 6
Dimensions		Measures	Section 8.1.4
Electrical resistance		Section 8.1.5.1	
Temperature rise		Section 8.3	Table 5
Power dissipation		Section 8.3	Table 4 of this standard
Conventional non-fusing current		Section 8.4.3.1 a)	Section 8.4.3.1 a)
Conventional fusing current		Section 8.4.3.1 b)	Section 8.4.3.1 b)
Rated current verification		Section 8.4.3.2	Section 8.4.3.2
Time-current characteristics, gates		Section 8.4.3.3	Section 8.4.3.3
Overload		Section 8.4.3.4	Section 8.4.3.4
Conventional cable overload protection		Section 8.4.3.5	Section 8.4.3.5
Indicating device		Section 8.4.3.6	Section 8.4.3.6
Breaking capacity		Section 8.5	Section 8.5
Cut-off current characteristic		Section 8.6.1	Section 8.6.2
I <sup>2</sup> t characteristic		Section 8.7	Section 8.7
Degree of protection		IEC 60529	Section 5.1.3
Resistance to heat		Section 8.9	Section 8.9
Non-deterioration of contacts		Section 8.10.2	Section 8.10.3
Mechanical strength		Section 8.11.1	Section 8.11.1
Freedom from season cracking *		Section 8.11.2.1	Section 8.11.2.1
Resistance to abnormal heat and fire	Section 8.11.2.2	Section 8.11.2.2	
Resistance to rusting	Section 8.11.2.3	Section 8.11.2.3	

\* For fuse-links with current-carrying parts made of rolled copper alloy with less than 83 % copper.

**Table 17 - Type-approval tests for fuse-holders**

Test	Number of samples	Method and conditions	Values to obtain and requirements
Marking	The number of fuse-holders to be tested are indicated in the standard IEC 60269-1	Visual examination	Section 6
Dimensions		Measures	Section 8.1.4
Insulating properties		Section 8.2	Section 8.2.5
Temperature rise Acceptable power dissipation		Section 8.3.4.1 Section 8.3.4.1	Table 4 Table 5 of this standard
Peak withstand current		Section 8.5	Section 8.5.8
Degree of protection		IEC 60529	Section 5.1.3
Resistance to heat		Section 8.9	Section 8.9
Non-deterioration of contacts		Section 8.10	Section 8.10
Mechanical strength		Section 8.11.1	Section 8.11.1
Freedom from season cracking*		Section 8.11.2.1	Section 8.11.2.1
Resistance to abnormal heat and fire		Section 8.11.2.2	Section 8.11.2.2
Resistance to rusting		Section 8.11.2.3	Section 8.11.2.3

\* For fuse-holders with current-carrying parts made of rolled copper alloy with less than 83 % copper.

	<b>GLOBAL STANDARD</b>	Page 36 of 39
	<b>LOW VOLTAGE FUSES (NH Knife Blade Fuse System)</b>	<b>GSC004 Rev. 0 23/11/2016</b>

### 12.3 Acceptance tests

The sections and tables indicated in Table 18 make reference to standard IEC 60269-1.

**Table 18 – Acceptance tests**

Ensayo	Number of samples	Method and conditions	Values to obtain and requirements
Marking	1% of the units of each size, with a minimum of 2 units	Visual examination	Section 6
Dimensions		Measures	Section 8.1.4
Cold electrical resistance		Electrical measurements	The values must be within the range indicated by the manufacturer for the corresponding fuse-link.
Centering of the fusible element	1% of the units of each size, with a minimum of one unit	Radiographic testing	The fuse element must be centered
Time-current characteristics	1% of the units of each size and rated current, with a minimum of one unit	Section 8.4.3.3.1	The values obtained should be within the zones time-current indicated by the manufacturer
Indicating device	1% of the units of each size, with a minimum of one unit	Section 8.4.3.6	Section 8.4.3.6
Characteristics of the components: - Non-ferrous metal parts.		Visual examination	Capsules correctly cut and with absence of stripes.
- Porcelain.		Visual examination	Absence of pores, chips or cracks

If an unsatisfactory result is obtained, a sample of double size is tested and the results should be fully satisfactory. If not, the entire batch will be rejected.

	<b>GLOBAL STANDARD</b>	Page 37 of 39
	<b>LOW VOLTAGE FUSES (NH Knife Blade Fuse System)</b>	<b>GSCl004 Rev. 0 23/11/2016</b>

### 13 ANNEX A

The manufacturer must specify, in detail, the data and information listed below:

#### General part

- Dimensional drawings.
- Pictures of fuse-links and fuse-holders.
- Operation curves.

#### Quality system

The manufacturers should have an approved quality system with the following methodical controls included:

- Supply of materials and components from outside providers.
- Materials and manufacturing.

The quality system must comply with ISO 9001: 2015.

	<b>GLOBAL STANDARD</b>	Page 38 of 39
	<b>LOW VOLTAGE FUSES (NH Knife Blade Fuse System)</b>	<b>GSCL004 Rev. 0 23/11/2016</b>

**14 ANNEX B**

Type code	Local code								
	Argentina	Brasil	Brasil	Chile	Colombia	Italia	Perú	Rumania	España
	Edesur	Ampla	Coelce	Chilectra	Codensa	e-distribuzione	Edelnor	Enel Distributie	Endesa Distribución Eléctrica
GSCL004/01	-----	-----	-----	-----	6806530	-----	-----	-----	-----
GSCL004/02	-----	-----	-----	-----	-----	-----	-----	617017	-----
GSCL004/03	-----	-----	-----	-----	6762391	-----	6757008	617018	-----
GSCL004/04	-----	-----	-----	-----	6762392	-----	6757009	617019	-----
GSCL004/05	-----	-----	-----	-----	6762393	-----	6757010	617020	-----
GSCL004/06	-----	-----	-----	-----	6762394	-----	6757011	617021	-----
GSCL004/07	-----	-----	-----	-----	6762443	-----	4631899	617022	-----
GSCL004/08	-----	-----	-----	-----	-----	174322	-----	-----	-----
GSCL004/09	-----	-----	-----	-----	-----	-----	-----	617025	6708642
GSCL004/10	-----	-----	-----	-----	-----	174323	-----	617026	6702961
GSCL004/11	-----	-----	-----	-----	-----	-----	-----	617027	6702962
GSCL004/12	-----	-----	-----	-----	-----	174324	-----	617028	6702963
GSCL004/13	-----	-----	-----	-----	-----	-----	-----	617030	6702964
GSCL004/14	-----	-----	-----	-----	-----	-----	-----	617031	6702965
GSCL004/15	-----	-----	-----	-----	-----	174325	-----	617032	-----
GSCL004/16	-----	-----	-----	-----	-----	-----	6757014	617033	6702966
GSCL004/17	-----	6776243	-----	-----	-----	174326	6757015	617034	6702967
GSCL004/18	-----	6810453	6807342	-----	-----	-----	6757016	617035	6702968
GSCL004/19	-----	6776244	6771150	-----	6762395	174327	6757017	617036	6702969
GSCL004/20	-----	6776245	-----	-----	-----	174328	6757018	617037	6702970
GSCL004/21	-----	-----	-----	-----	-----	-----	6757019	617039	6708651
GSCL004/22	-----	-----	-----	-----	-----	-----	-----	617040	-----
GSCL004/23	-----	-----	-----	-----	-----	-----	-----	617041	-----
GSCL004/24	-----	-----	-----	-----	-----	-----	-----	617042	6700311
GSCL004/25	-----	-----	-----	-----	-----	-----	-----	617043	6700312
GSCL004/26	-----	-----	-----	6751347	-----	-----	-----	617044	6700313
GSCL004/27	-----	-----	-----	6751354	-----	-----	6757021	617045	6700314
GSCL004/28	-----	-----	6807341	6751357	6762396	-----	-----	617046	6700315
GSCL004/29	-----	6776247	6771151	6751355	6762503	174329	6757022	617048	6700316



**GLOBAL STANDARD**

**LOW VOLTAGE FUSES  
(NH Knife Blade Fuse System)**

**GSCl004  
Rev. 0  
23/11/2016**

GSCl004/30	-----	6808633	-----	6751351	-----	174330	6757023	617050	6700317
GSCl004/31	-----	6776248	-----	6751356	6762502	-----	6757024	617051	-----
GSCl004/32	-----	-----	6771152	-----	-----	-----	6757028	617052	6700318
GSCl004/33	-----	-----	-----	-----	-----	-----	6757029	617053	-----
GSCl004/34	-----	6778571	-----	-----	-----	-----	6757030	617054	-----
GSCl004/35	-----	6776249	-----	-----	-----	-----	6757031	617055	6708652
GSCl004/36	-----	-----	-----	-----	-----	174314	-----	-----	-----
GSCl004/37	-----	-----	-----	-----	-----	174350	-----	-----	-----
GSCl004/38	-----	-----	-----	-----	-----	174315	-----	-----	-----
GSCl004/39	-----	-----	-----	-----	-----	174351	-----	-----	-----
GSCl004/40	-----	-----	-----	-----	-----	174352	-----	-----	-----
GSCl004/41	-----	-----	-----	-----	-----	174316	-----	-----	-----
GSCl004/42	-----	-----	-----	-----	-----	174353	-----	-----	-----
GSCl004/43	-----	-----	-----	-----	-----	174317	-----	-----	-----