



For System I Game

Operators Manual

with Illustrated Parts Lists

RoadBlasters™

For technical assistance:

If reading through this manual does not lead to solving a maintenance or repair problem, call TELEHELP® at one of these Atari Games Customer Service offices:

UNITED STATES

Atari Games Corporation
California Customer Service Office
737 Sycamore Drive
P.O. Box 361110
Milpitas, CA 95035

Fax (408) 434-3945

Telex 5101007850

(Monday-Friday, 7:30-4:00 pm Pacific Time)

☎ **(408) 434-3950**

EUROPE

Atari Games Ireland Limited
European Customer Service Office
Tipperary Town, Ireland

Fax 062-51702

Telex 28165

(Monday-Friday, 9:00-5:30 pm GMT)

☎ **062-52155**

Road Blasters™ Operators Manual

with Illustrated Parts Lists
For System I™ Game



© 1987 by Atari Games Corporation **All rights reserved**

No part of this publication may be reproduced by any mechanical, photographic, or electronic process, or in the form of a phonographic recording, nor may it be stored in a retrieval system, transmitted, or otherwise copied for public or private use, without permission from the publisher.

The game play, all graphic designs, this technical manual, its accompanying schematic diagrams, and the display manual are protected by the U.S. Copyright Act of 1976.

This Act provides for increased penalties for violating federal copyright laws. Courts *can impound* infringing articles while legal action is pending. If infringers are convicted, courts can *order destruction* of the infringing articles.

In addition, the Act provides for payment of statutory damages of up to \$250,000 in certain cases. Infringers may also have to pay costs and attorneys' fees and face an imprisonment of up to five years.

Atari Games Corporation will aggressively enforce its copyrights against any infringers. *We will use all legal means* to immediately halt any manufacture, distribution, or operation of a copy of video games made by us. Anyone who purchases such copies risks forfeiting such a game.

Published by: Atari Games Corporation
675 Sycamore Drive
P.O. Box 361110
Milpitas, California 95035

Printed in the U.S.A. **4R**



Table of Contents

Notice Regarding Non-ATARI® Parts

▲ WARNING ▲

Use of non-ATARI parts or modifications of any ATARI game circuitry may adversely affect the safety of your game, and may cause injury to you and your players.

You may void the game warranty (printed on the inside back cover of this manual) if you do any of the following:

- Substitute non-ATARI parts in the game.
- Modify or alter any circuits in the game by using kits or parts *not* supplied by Atari Games Corporation.

NOTE

This equipment generates, uses, and can radiate radio frequency energy and if not installed and used in accordance with the instruction manual, may cause interference to radio communications. It has been tested and found to comply with the limits for a Class A computing device pursuant to Subpart J of Part 15 of Federal Communications Commission (FCC) Rules, which are designed to provide reasonable protection against such interference when operated in a commercial environment. Operation of this equipment in a residential area or modification to this equipment is likely to cause interference in which case the user, at his own expense, will be required to take whatever measures may be required to correct the interference. If you suspect interference from an ATARI® game at your location, check the following:

- All ground wires in the game are properly connected as shown in the game wiring diagram.
- The power cord is properly plugged into a grounded three-wire outlet.
- On games provided with an Electromagnetic Interference (EMI) ground plane, be sure the game printed-circuit boards (PCBs) are properly installed on the EMI Ground Plane. If you are still unable to solve the interference problem, please contact Customer Service at Atari Games Corporation. See the inside front cover of this manual for service in your area.

Table of Contents

1 Set-Up	
How to Use This Manual	1-1
Inspecting the Game	1-2
Control and Switch Locations	1-2
Setting the Coin and Game Options	1-3
Power Supply Fuses	1-3
Game Play	1-3
2 Self-Test	
RAM//ROM Test	2-2
Switch Test	2-2
Coin Options	2-3
Game Options	2-3
Statistics	2-4
Histograms	2-4
Playfield Test	2-5
Control Test	2-5
Motion Object Test	2-6
Motion Object Height Test	2-6
Alphanumerics Test	2-6
Color Test	2-6
Color Purity Test	2-7
Convergence Test	2-7
Sound Test	2-7
3 Maintenance	
Preventive Maintenance	3-2
Preventive-Maintenance Intervals	3-2
Removing the Control Panel	3-2
Maintaining the RTC Steering Control	3-2
Cleaning the Coin Mechanism	3-2
Cleaning the Interior Components	3-2
Corrective Maintenance	3-4
Removing the RTC Steering Control	3-4
RTC Steering Control	3-6
Removing the Video Display	3-7
Removing the Foot Pedal Control	3-8
Removing the Main PCB	3-8
Removing the Fluorescent Light Assembly	3-9
Removing the Speakers	3-9
4 Troubleshooting	
Troubleshooting Aids	4-2
Troubleshooting Techniques	4-2
Soldering Techniques	4-2
Troubleshooting Static-Sensitive Devices	4-3
5 Illustrated Parts Lists	
See List of Illustrations that follows.	
6 Kit Installation	
Introduction	6-1
Kit Parts Inventory	6-1
Tools Required	6-1
Conversion Instructions	6-3
Setting the Coin and Game Options	6-6
Reset the High Score Table and the Accounting Information	6-6

Road Blasters Coin Information and Game Statistics Sheet

See last page of this manual.

List of Illustrations

Figure 1-1	Control and Switch Locations	1-3
Figure 1-2	Switching/Linear (SL) Power Supply Fuse Locations	1-4
Figure 2-1	ROM Test Fails	2-2
Figure 2-2	RAM Test Fails	2-2
Figure 2-3	Switch Test	2-3
Figure 2-4	Coin Options	2-3
Figure 2-5	Game Options	2-4
Figure 2-6	Statistics	2-4
Figure 2-7	Histograms	2-5
Figure 2-8	Playfield Test	2-5
Figure 2-9	Control Test	2-5
Figure 2-10	Motion Object Test	2-6
Figure 2-11	Motion Object Height Test	2-6
Figure 2-12	Alphanumerics Test	2-7
Figure 2-13	Color Test	2-7
Figure 2-14	Color Purity Test	2-7
Figure 2-15	Convergence Test	2-7
Figure 2-16	Sound Test	2-8
Figure 3-1	Control Panel Removal	3-3
Figure 3-2	RTC Steering Control Disassembly and Lubrication	3-4
Figure 3-3	Video Display Removal	3-8
Figure 3-4	Main PCB Removal	3-9
Figure 3-5	Fluorescent Light Assembly Removal	3-9
Figure 3-6	Speaker Removal	3-10
Figure 4-1	Removing IC (Cut-Pin Method)	4-3
Figure 4-2	Removing IC Pins	4-3
Figure 4-3	Removing Solder from Plated-Through Holes	4-4
Figure 4-4	Removing Solder from Lead Connection Pads	4-4
Figure 5-1	Cabinet-Mounted Assemblies	5-2
Figure 5-2	Control Panel Assembly	5-6
Figure 5-3	RTC Steering Control Assembly	5-8
Figure 5-4	Fluorescent Light Panel Assembly	5-11
Figure 5-5	Switching/Linear (SL) Power Supply Assembly	5-12
Figure 5-6	Foot Pedal Assembly	5-16
Figure 5-7	Coin Acceptors, Inc. Coin Door Assembly	5-18
Figure 5-8	Printed-Circuit Board Mounting Hardware	5-21
Figure 5-9	LSI Main PCB Assembly	5-22
Figure 5-10	LSI Cartridge 3 and 4 PCB Assemblies	5-26
Figure 5-11	Audio II PCB Assembly	5-30
Figure 6-1	Kit Part Locations	6-2
Figure 6-2	Attraction Film Replacement	6-3
Figure 6-3	Control Panel and Foot Pedal Installation	6-4

List of Tables

Table 1-1	Game Specifications	1-2
Table 2-1	Faulty ROM Locations	2-2
Table 2-2	Coin Option Settings	2-3
Table 2-3	Game Option Settings	2-5
Table 6-1	Kit Parts Inventory	6-3

Safety Summary

The following safety precautions apply to all game operators and service personnel. Specific warnings and cautions will be found throughout this manual where they apply.

⚠ WARNING ⚠

Properly Ground the Game. Players may receive an electrical shock if this game is not properly grounded! To avoid electrical shock, do not plug in the game until it has been inspected and properly grounded. This game should only be plugged into a grounded three-wire outlet. If you have only a 2-wire outlet, we recommend you hire a licensed electrician to install a grounded outlet. Players may receive an electrical shock if the control panel is not properly grounded! After servicing any parts on the control panel, check that the grounding wire is firmly secured to the inside of the control panel. Only then should you lock up the game.

AC Power Connection. Before connecting the game to the AC power source, verify that the game's power supply is properly configured for the line voltage in your location.

Disconnect Power During Repairs. To avoid electrical shock, disconnect the game from the AC power source before removing or repairing any part of the game. When removing or repairing the video display, extra precautions must be taken to avoid electrical shock because high voltages may exist within the display circuitry and cathode-ray tube (CRT) even after power has been disconnected. Do not touch internal parts of the display with your hands or with metal objects! Always discharge the high voltage from the CRT before servicing this area of the game. To discharge the CRT: Attach one end of a large, well-insulated, 18-gauge jumper wire to ground. Momentarily touch the free end of the grounded jumper to the CRT anode by sliding it under the anode cap. Wait two minutes and discharge the anode again.

Use Only ATARI Parts. To maintain the safety integrity of your ATARI game, do not use non-ATARI parts when repairing the game. Use of non-ATARI parts or other modifications to the game circuitry may adversely affect the safety of your game, and injure you or your players.

Handle the CRT With Care. If you drop the CRT and it breaks, it may implode! Shattered glass can fly six feet or more from the implosion.

Use the Proper Fuses. To avoid electrical shock, use replacement fuses which are specified in the parts list for this game. Replacement fuses must match those replaced in fuse type, voltage rating, and current rating. In addition, the fuse cover must be in place during game operation.

CAUTION

Properly Attach All Connectors. Make sure that the connectors on each printed-circuit board (PCB) are properly plugged in. Note that they are keyed to fit only one way. If they do not slip on easily, do not force them. A reversed connector may damage your game and void the warranty.

Ensure the Proper AC Line Frequency. Video games manufactured for operation on 60 Hz line power (i.e., United States) must not be operated in countries with 50 Hz line power (i.e., Europe). The fluorescent light ballast transformer will overheat, causing a potential fire hazard if 60 Hz games are operated on power lines using 50 Hz. Check the product identification label of your game for the line frequency required.

ABOUT NOTES, CAUTIONS, AND WARNINGS

In all Atari publications, notes, cautions, and warnings have the following meaning:

NOTE—A highlighted piece of information.

CAUTION—Equipment and/or parts can be damaged or destroyed if instructions are not followed. You will void the warranty on Atari printed-circuit boards, parts thereon, and video displays if equipment or parts are damaged or destroyed due to failure of following instructions.

WARNING—Players and/or technicians can be injured or killed if instructions are not followed. (The word *WARNING* is always surrounded by international warning symbols—triangles with exclamation marks inside of them.)

Chapter 1

Set-Up

How to Use This Manual

Your System I™ cabinet is designed to be used for a variety of games. The System I cabinet comes with a System I game installed at the factory. However, if you already have a System I cabinet, any available System I game can be purchased as a kit for easy installation. This operators manual is for the Road Blasters™ game, and is supplied either with System I cabinets that have the Road Blasters game installed at the factory or with Road Blasters kits that can be installed in the field.

This manual includes information for setting up, playing, and maintaining your System I Road Blasters game. If you have purchased a Road Blasters kit to change an existing System I game into a Road Blasters game, Chapter 6 of this manual contains all the necessary information for installing the game kit. This manual is divided into the following chapters:

- Chapter 1 contains set-up and game play information.
- Chapter 2 contains self-test procedures.
- Chapter 3 contains preventive and corrective maintenance procedures.
- Chapter 4 contains troubleshooting information.
- Chapter 5 contains illustrated parts lists.
- Chapter 6 contains procedures for installing the Road Blasters kit.

Wiring and schematic diagrams for the System I Road Blasters game circuitry are contained in the Schematic Package Supplement (SP-298) included with your game.

This chapter includes information required to set up and play your Road Blasters game. Carefully read the information in this chapter before applying power to the game.

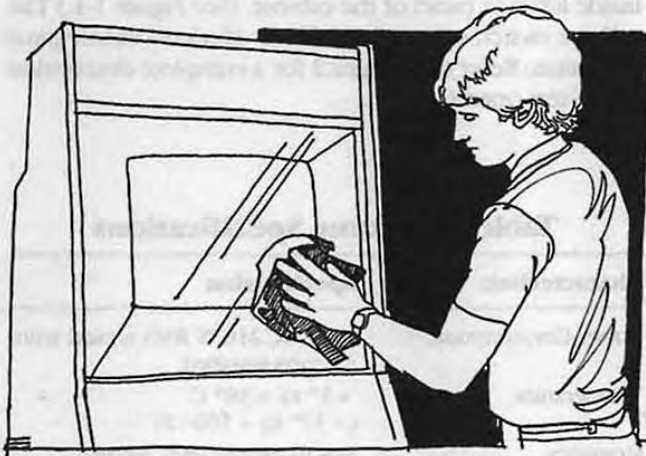

⚠ WARNING ⚠

To avoid electrical shock, do not plug in the cabinet until it has been properly inspected and set up for the line voltage in your area.

This cabinet should only be connected to a grounded three-wire outlet. If you have only a two-wire outlet, we recommend that you hire a licensed electrician to install a grounded outlet. Players can receive an electrical shock if the cabinet is not properly grounded.

Do not touch internal parts of the display with your hands or with metal objects.

Inspecting the Game

⚠ WARNING ⚠

Do not plug in the game until you have completed the following inspection steps.

Please inspect your System I Road Blasters game (or kit) carefully to ensure that the game (or kit) is complete and delivered to you in good condition. Figure 6-1 shows the locations of the component parts of the assembled game. Refer to Chapter 6 for a list of the kit parts. Table 1-1 lists space, power, and environmental requirements.

Inspect the factory-assembled game as follows:

1. Examine the exterior of the cabinet for dents, chips, or broken parts.
2. Unlock and open the rear access panel. Unlock and open the coin doors. Inspect the interior of the cabinet as follows:
 - a. Ensure that all plug-in connectors (on the cabinet harnesses) are firmly plugged in. Do not force connectors together. The connectors are keyed so they only fit in the proper orientation. *A reversed edge connector can damage a printed-circuit board (PCB) and will void your warranty.*
 - b. Ensure that all plug-in integrated circuits on each PCB are firmly plugged into their sockets.
 - c. Inspect the power cord for any cuts or dents in the insulation.
 - d. Inspect the power supply. Make sure that the correct fuses are installed. Check that the harness is plugged in correctly and that the fuse block cover is mounted in place. Check that the green ground wire is connected.
 - e. Inspect other major sub-assemblies, such as the video display, printed-circuit boards (PCBs), speakers, and the fluorescent tube. Make sure they

are mounted securely and that the green ground wires are connected.

Inspect the Road Blasters kit as follows:

1. Verify that all of the Road Blasters kit parts listed in Table 6-1 of this manual are included in your kit.
2. Examine the kit parts for dents, chips, or broken parts.

Control and Switch Locations

Power On/Off Switch

The power on/off switch is located at the bottom rear of the cabinet. (See Figure 5-1.)

Volume Control

The volume control is located on the Audio II PCB on the inside left side panel of the cabinet. (See Figure 1-1.) The volume control adjusts the level of sound produced by the game.

Coin Counter

The coin counter is located on the inside left side panel of the cabinet. The coin counter records the number of coins deposited.

Self-Test Switch

The self-test switch is located on the Audio II PCB on the inside left side panel of the cabinet. (See Figure 1-1.) The self-test switch selects the Self-Test Mode to check game operation. Refer to Chapter 2 for a complete description of self-test operation.

Table 1-1 Game Specifications

Characteristic	Specification
Power Consumption	255 V-A, 210 W RMS typical with kit parts installed
Temperature	+5° to +38° C (+37° to +100° F)
Humidity	Not to exceed 95% relative
Line Voltage	102 to 132 VAC (U.S. games) 198 to 264 VAC (Irish games)
Width	25.50 in. (65 cm)
Depth	35 in. (89 cm)
Height	70 in. (178 cm)
Weight	327 lbs. (148 kg) maximum with kit parts installed

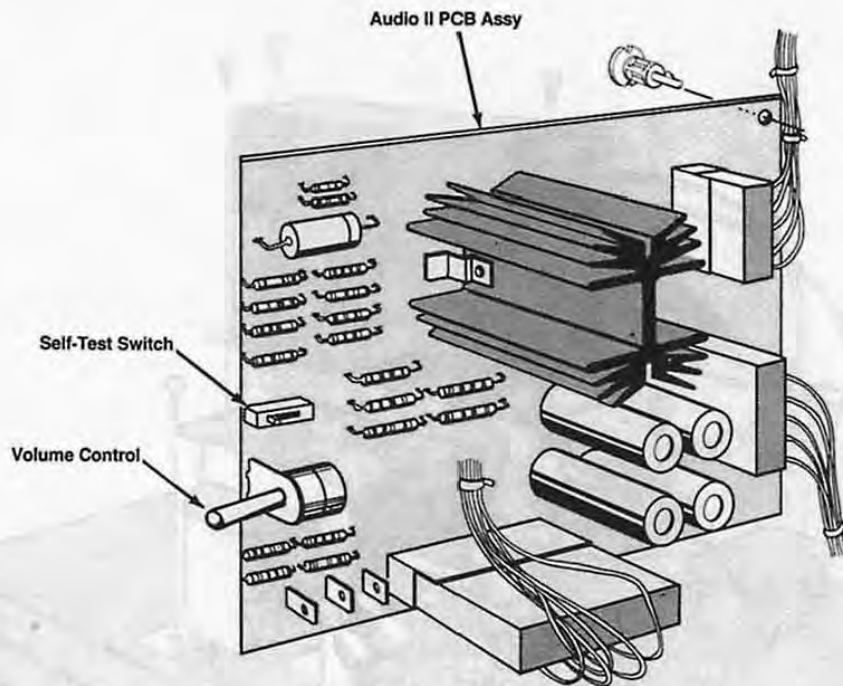

Figure 1-1 Control and Switch Locations

Setting the Coin and Game Options

The Road Blasters coin and game options are set in the Self-Test Mode. Refer to Chapter 2 for the recommended settings and the procedure for setting the options.

Power Supply Fuses

The power supply in your game contains three fuses. When you replace a fuse, use the identical type fuse with the same electrical rating. (See Figure 1-2.) Also, be sure to put the replacement fuse in the correct location.

Game Play

This section of the manual describes the theme of the Road Blasters game, the operating modes, and the game play features.

Introduction

Road Blasters is an action-packed battle game where the player drives a high-performance armored car. Road Blasters features a new return-to-center (RTC) steering control with fire buttons to highlight the realistic driving perspective and added action element of laser artillery and unique special weapons.

Atari Games has designed Road Blasters in cooperation with Matchbox Toys, a company famous for its authenti-

cally detailed collectible die-cast cars. Road Blasters is a new Matchbox line of futuristic action/adventure vehicles.

Attract Mode

The Attract Mode begins when the game is powered up or after exiting the Play or Self-Test Modes. The Attract Mode ends when coins or tokens are inserted and the gas pedal is pressed. The Attract Mode continuously cycles through the following displays:

- Road Blasters title screen
- Game play demonstration
- Screen displaying The Enemy and their respective point values
- High score table
- Contest information (U.S. and Canada only)

Unique Features to Attract Players

- Tie-in with the Matchbox Road Blasters line of action/adventure vehicles. Matchbox Toys will support its Road Blasters line with television advertising in the spring and fall of 1987, in addition to retail promotions and an ambitious public relations campaign. As an amusement game operator owning a Road Blasters video game, you will profit from the public awareness created by Matchbox Toys.
- A special player contest (in the U.S. and Canada only) to promote increased play on the game. Players who

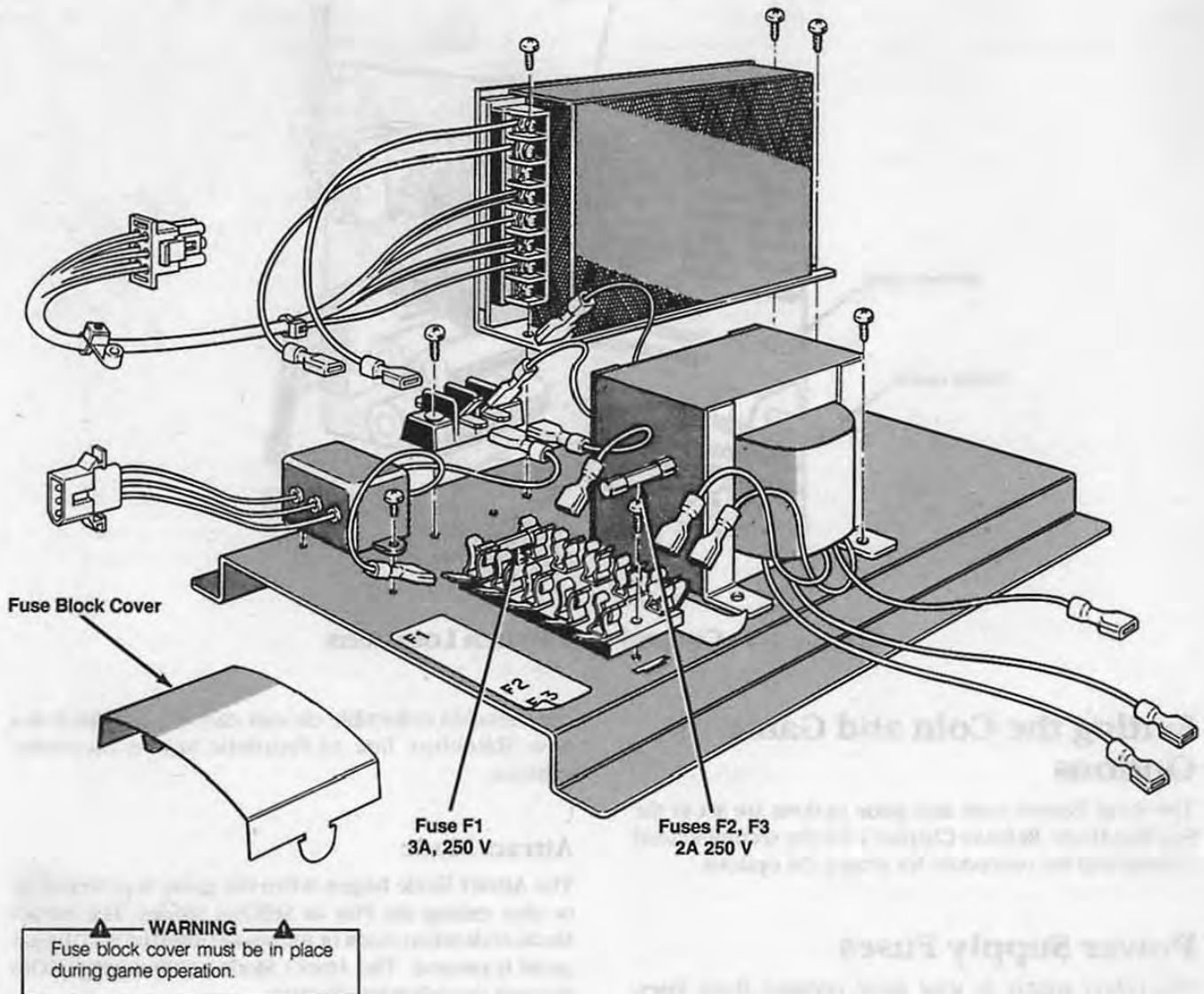

Figure 1-2 Switching/Linear (SL) Power Supply Fuse Locations

complete rally 50 are asked to enter their name and obtain a secret code. When mailed to Atari Games, this secret code entitles the player to a specially designed Road Blasters T-shirt. Detailed rules are on the marquee packaged with your Road Blasters game.

Play Mode

Road Blasters is the Ultimate Race of the Future—being part road race and part combat-zone survival exercise.

The roadway leads the player through a progression of countries, alternating checkpoints, and rally points.

Checkpoints are mid-point goals that award additional fuel as the player races past. Rally points are similar to finish lines in ordinary race games because they indicate the completion of a race section. In the case of Road Blasters, a scroll-up video display evaluates player performance at each rally point. The game ends when the players run out of fuel by driving too slow, being destroyed by opponents, or crashing too often.

Player controls consist of an RTC steering control with triggers and thumb firing buttons, and a gas pedal. The triggers control the laser gun; the thumb buttons ignite the special weapons.

Players can tag the green and red fuel globes placed along the roadway to obtain more fuel. As a reward, their cars are also refueled when they reach each checkpoint and rally point.

Four unique computer-controlled opponent vehicles challenge players: sleek, fast Stingers; heavily armored Command cars; evasive and unpredictable Rat Jeeps; and quick, darting Cycles. These vehicles combine forces to try to prevent the players from reaching the next rally point. In addition, there are mines in the road, gun turrets on the side of the road shooting at the players, spikers thrown by opponent vehicles, and other obstacles to be avoided.

The player can dock with the special attribute pack dropped by the support jet to acquire special weapons. Special weapons include: Cruise Missiles that destroy everything in the path of the player that is visible on the screen; Nitro Injectors that boost the speed of the player's car; U.Z. Cannons that rapid-fire; and Electro Shields that protect the player's car from shots, collisions, mines, and spikers.

High Score Mode

Upon completing a game and if players are among the top ten scorers recorded on the game, they have 17 seconds to enter their first initial and another 17 seconds for the next initial, until all have been entered. Players select their initials by pressing the thumb buttons or the triggers. Players can correct their initials by selecting the arrow that points to the left, then repeating the procedure for entering their correct initials.

To encourage high score competitiveness among players, your Road Blasters game automatically resets the high score table to the default list of players' initials and scores. During normal use (when the game is turned off at closing time), the top four scores are reset if more than 200 sequential games have elapsed and no players have entered their initials as one of the top four scores. This interval is about once a week; the reset occurs during power-up. Scores 5 through 10 are reset daily during power-up.

Maximizing Earnings

Operator options on this game have been kept very simple. You should thoroughly read Chapter 2, Self-Test, for the Coin Options, Game Options, Histograms, and Statistics screens so that you can effectively use the available options. Use the Self-Test screens showing Statistics and Histograms to evaluate game data, and the Game Options screen to make adjustments. (Refer also to the Self-Test chapter for more information on setting options.)

The key to maximum earnings is striking a midpoint on game times. Game times must be short enough so that player turnover is high. Conversely, game times must be long enough to give players a good value and ensure re-

peat play. (Repeat play is crucial to longevity.) The Road Blasters software gives the operator the flexibility to tune game difficulty and enough statistics to intelligently make adjustments.

If collections seem low or are dropping off, check all player controls and coin mechanisms for proper operation.

If earnings seem low, the game is technically sound and the average game time is under 110 seconds, try changing the game difficulty option to an easier setting. This change will give players more game time relative to their score.

If the average game time is over 180 seconds, first try changing the game difficulty to a harder setting. If the average game time is still over 180 seconds after a few weeks, try an even harder setting.

NOTE

Be sure to keep the factory default at *no* if you wish to try other than factory-recommended settings.

After changing the game difficulty settings, it is a good idea to reset the game statistics. The coin information and game statistics should be cleared in self-test by pressing the foot pedal; this resets the average game time statistic. In addition, the histograms should be cleared by pressing the foot pedal while displaying the level 5 Histogram screen.

Game Sounds

Your System I cabinet with the Road Blasters game uses more effective audio than previous games, which results in more player involvement and enjoyment. The System I games use advanced digital sound-generation techniques to create realistic musical instrument sounds (such as clarinets, harmonicas, drums, and violins). Although a player may not be consciously aware of the music, it has a direct effect on the excitement and emotional experience of the game.

The Road Blasters game creates ear-catching sound effects, which are designed to give feedback to make the player believe that the game is responding directly to his actions. To maximize the player's enjoyment of this enhanced audio and maximize your earnings, consider the following hints:

1. The game location should be a relatively dead acoustical environment. The goal is to minimize unnecessary sound reflection, so that the sounds from the Road Blasters game won't be drowned out by the accumulation of other sounds that bounce around the room. Carpets help eliminate sound reflections from the floor. Acoustical tile is also useful, especially if you have low ceilings.

2. If you use an environmental sound system or a stereo, consider lowering its volume or perhaps even turning it off. In the days when video games just made harsh beeps and boops, a central sound system helped make up for the lack of drive and excitement in a game's sounds. But your Road Blasters game is very musical, and a sound system interferes with the game's ability to interest players and draw bystanders.
3. Be concerned with the overall volume levels in arcade environments. The goal is to involve the players' emotions, not to damage their hearing. To a certain point,

raising the game volume helps add to player excitement, but above that level it creates hearing fatigue and the high volume starts to drive players away. Rather than turning up the volume on the Road Blasters games to cut through the background sound level, try lowering the volume of any neighboring games that have sounds which are not an attractive or important element. Careful placement of games and attention to unnecessary noise sources can also help increase the player's sense of game involvement and interaction.

If the program can't find the game, check the game's location in the program's file list. If the program can't find the game, check the game's location in the program's file list.



When changing the game's location, the program will ask you to confirm the new location. The program will then search for the game in the new location. If the program can't find the game, check the game's location in the program's file list.

Game Sounds

The game's sound system is designed to provide an immersive experience. The game's sound system is designed to provide an immersive experience. The game's sound system is designed to provide an immersive experience.

The game's sound system is designed to provide an immersive experience. The game's sound system is designed to provide an immersive experience. The game's sound system is designed to provide an immersive experience.

The game's sound system is designed to provide an immersive experience. The game's sound system is designed to provide an immersive experience. The game's sound system is designed to provide an immersive experience.

The game's sound system is designed to provide an immersive experience. The game's sound system is designed to provide an immersive experience. The game's sound system is designed to provide an immersive experience.

High Score Mode

When playing a game, the player's score is recorded. The player's score is recorded. The player's score is recorded. The player's score is recorded.

The game's high score mode is designed to provide an immersive experience. The game's high score mode is designed to provide an immersive experience. The game's high score mode is designed to provide an immersive experience.

Maximizing Earnings

The game's earnings are determined by the player's performance. The game's earnings are determined by the player's performance. The game's earnings are determined by the player's performance.

The game's earnings are determined by the player's performance. The game's earnings are determined by the player's performance. The game's earnings are determined by the player's performance.

Chapter 2

Self-Test

The Road Blasters™ game tests itself and provides visual and audible indications of the condition of the game circuitry. Self-test information is displayed on the screen and through the sound system. No additional equipment is required.

We suggest that you perform a self-test when you first set up the game, each time you collect the money, or when you suspect game failure. Coin and game options are selected in the Self-Test Mode.

After the self-test switch is turned on, 16 self-test screens provide information pertaining to the game circuits. Refer to Chapter 1 for the location of the self-test switch.

When the self-test switch is turned on, and the power is then turned on, the game enters the full Self-Test Mode. If the self-test switch is turned on when the game is in the Attract Mode, the game enters a shorter Self-Test Mode. The following self-test screens are arranged in the sequence in which they occur after the self-test switch is first turned on. After the Sound Test, the sequence starts over with the Switch Test. Turning the self-test switch off at any time during the Self-Test Mode causes the game to return to the Attract Mode.

NOTE

During any of the self-tests, press the thumb button on the RTC (return-to-center) steering control to advance to the next screen.

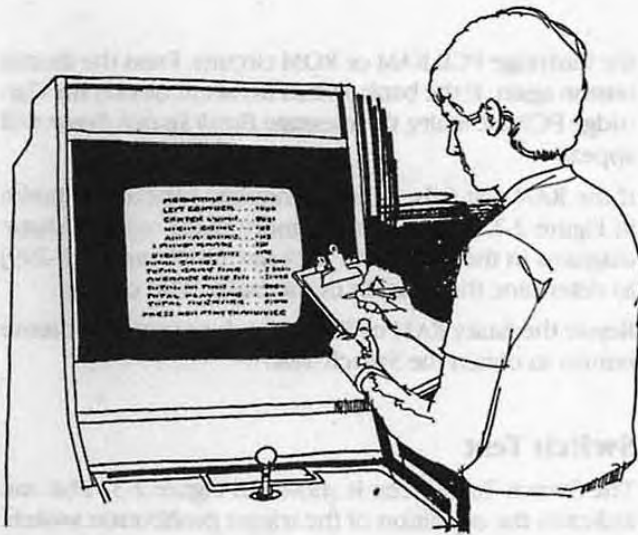

RAM/ROM Test

The RAM/ROM Test screens are shown in Figures 2-1 and 2-2. These tests provide a visual check of the game RAM, ROM, and associated circuitry. If the RAM and ROM test passes, the display advances to the Switch Test.

The RAM/ROM Test is divided into two sections. The condition of the RAM circuitry is displayed in the bottom half of the screen and, after about an eight-second delay, the condition of the ROM circuitry is displayed in the top half of the screen. An error message indicates that the RAM, ROM, or associated circuitry may be faulty.

If the ROM test fails, an error message appears in the top half of the screen as shown in Figure 2-1. Refer to Table 2-1 for the faulty ROM locations.

If the upper or lower main memory ROM circuits on the Main PCB fail, an *Upper or Lower Main ROM Error* message appears at the top of the screen. Press the thumb button to obtain any RAM or ROM error message(s) from



Figure 2-1 ROM Test Fails

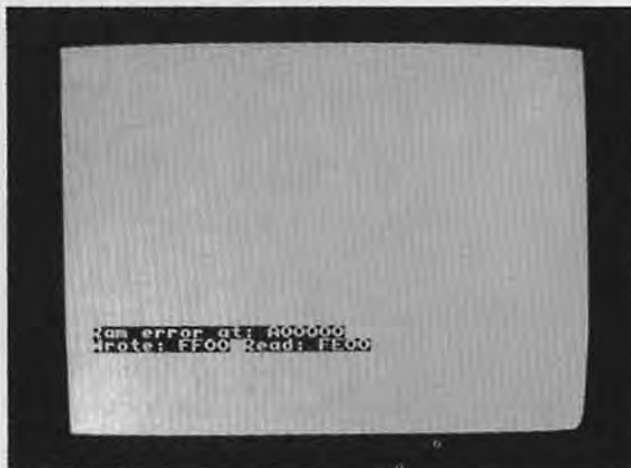

Figure 2-2 RAM Test Fails

Table 2-1 Faulty ROM Locations

Error Message	Location on Cartridge 3 PCB Assy
ROM at 10000 error	U = 11C L = 11A
ROM at 20000 error	U = 13C L = 13A
ROM at 50000 error	U = 12C L = 12A
ROM at 60000 error	U = 14C L = 14A
ROM at 70000 error	U = 16C L = 16A
Bank switch error	

Error Message	Location on Cartridge 4 PCB Assy
ROM at 10000 error	U = 11C L = 11A
ROM at 20000 error	U = 13C L = 13A
ROM at 50000 error	U = 11C L = 11A
ROM at 60000 error	U = 13C L = 13A
ROM at 70000 error	U = 16C L = 16A
Bank switch error	

the Cartridge PCB RAM or ROM circuits. Press the thumb button again. If the bank switch ROM circuits on the Cartridge PCB are faulty, the message *Bank Switch Error* will appear.

If the RAM test fails, an error message appears as shown in Figure 2-2. Refer to the memory maps and schematic diagrams in the *Schematic Package Supplement (SP-299)* to determine the location of the faulty RAM circuit.

Repair the faulty RAM or ROM circuit or press the thumb button to obtain the Switch Test.

Switch Test

The Switch Test screen is shown in Figure 2-3. This test indicates the condition of the trigger pushbutton switch. Press the trigger button, and note that the first number changes to a 1.

Press the thumb button to obtain the next screen.



Figure 2-3 Switch Test



Figure 2-4 Coin Options

NOTE

For all subsequent tests in the self-test, the following summarizes the functions of the various switches:

- The thumb button sequences to the next test.
- The foot pedal has an action function. For example, in the convergence test pressing the pedal changes the grid lines from white to violet; in the sound test, the audio starts sounding.
- The RTC steering control left-to-right movement selects choices. (Right/left arrows are displayed in the upper right corner on the screen.)
- The trigger switch, if pressed, changes the RTC steering control to show up/down movement on the screen. (Up/down arrows are displayed in the upper right corner of the screen.)

Coin Options

The Coin Options screen is shown in Figure 2-4. This screen indicates the current coin option settings and is used to change these settings. Refer to Table 2-2 for the available and recommended settings.

NOTE

If you wish to try other than factory-recommended options, leave the *Restore Factory Options* setting at *no*.

Coin Mode should be highlighted. Move the RTC steering control right or left, and note that the coin mode values change. Select the desired value. Move the RTC steering control to the right (while the trigger switch is pressed); this moves the box to *Right Mech Multiplier*. Move the

Table 2-2 Coin Option Settings

Option Name	Available Settings
Credit Mode	1 Coin 1 Credit ◀ 2 Coins 1 Credit 3 Coins 1 Credit 4 Coins 1 Credit
Right Mech Multiplier	1 Coin Counts as 1 Coin ◀ 1 Coin Counts as 4 Coins 1 Coin Counts as 5 Coins 1 Coin Counts as 6 Coins
Left Mech Multiplier	1 Coin Counts as 1 Coin ◀ 1 Coin Counts as 2 Coins
Bonus Adder	No Bonus Adder ◀ 2 Coins Give 1 Extra Coin 4 Coins Give 1 Extra Coin 4 Coins Give 2 Extra Coins 5 Coins Give 1 Extra Coin 3 Coins Give 1 Extra Coin Free Play

◀ *Manufacturer's recommended settings*

RTC steering control right or left (without pressing the trigger switches) to cycle through all the available multiplier values. Select the desired value. Repeat this procedure for the remaining options.

If you wish to cancel the option changes and restore the original settings, press the foot pedal.

Press the thumb button to set the selected coin options and to obtain the next screen.

Game Options

The Game Options screen is shown in Figure 2-5. This screen indicates the current game option settings and is

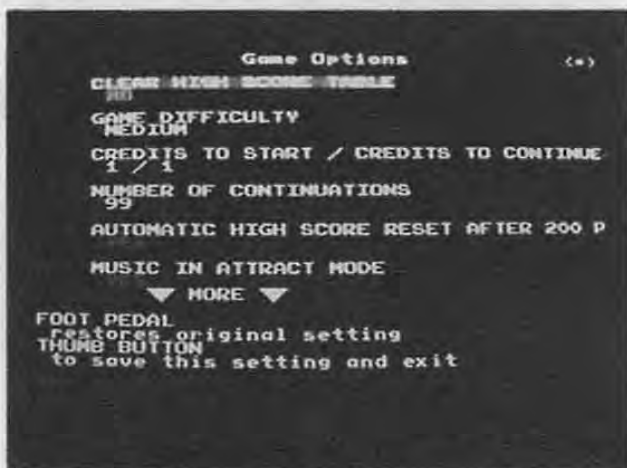

Figure 2-5 Game Options

used to reset the high score table and to change the game option settings. Refer to Table 2-3 for the available options and the default (recommended) settings. Note that the recommended settings are highlighted in green.

Move the RTC steering control right or left and note that the settings for the option in the shaded block change. Select the desired value. Press the trigger switch and simultaneously move the RTC steering control left/right to move the desired option into the shaded block. Move the RTC steering control right or left (without pressing the trigger switch) to cycle through all the available game option settings and select the desired value. Repeat this procedure for the remaining options.

If you want to cancel the option changes and restore the original settings, press the foot pedal.

Press the thumb button to set the selected game options and to obtain the next screen.

Statistics

The Statistics screen is shown in Figure 2-6. This screen provides a visual check of the current game statistics. The statistics information is accumulated either from the first time the game was turned on or from the last time the statistics were reset. To reset the statistics information, press the foot pedal.

The following information appears on the Statistics screen:

- *Aux coins* is not used in the Road Blasters game.
- *Left coins* shows the number of coins deposited in the left coin mechanism.
- *Right coins* shows the number of coins deposited in the right coin mechanism.
- *1 plyr Games* shows the number of 1-player games.
- *Mins played* shows the total time, in minutes, of all the games played.



Figure 2-6 Statistics

- *Mins per up* shows the total time, in minutes, that the game has been turned on.
- *Aux. cntr 1* shows the highest rally achieved.
- *Aux. cntr 2* shows the total number of times the add-a-coin continuation was used.
- *Aux. cntr 3* shows the number of games without a new entry into the top four scores.
- *Error count* shows the number of EEPROM errors that were detected. If the errors detected exceed about 75 per week, replace one EEPROM on the Main PCB Assembly at this location: 15F on the TTL Main PCB or 13E on the LSI Main PCB.
- *Avg. Game Time* shows the average game time per play in seconds, including add-a-coin continuation games.

Press the thumb button to obtain the next screen.

Histograms

There are five Histogram screens. One screen is shown in Figure 2-7. The screens are selected by pressing the thumb button. Each screen shows the lengths of the games from 0 to 540 or more seconds and the total number of players. The high score for each level is also displayed.

The Histograms for Levels 1 through 3 show the players' wave selections (choosing from Rookie, Veteran, or Expert). The Histogram for Level 4 shows the number of games that ended on the original level of the game continuation feature. The Histogram for Level 5 shows the number of games that ended on a higher level after a game continuation.

The game times information is accumulated either from the first time the game was turned on or from the last time the game times were reset. To reset the Histograms, press the foot pedal while displaying the Histogram for the Level 5 screen.

Table 2-3 Game Option Settings

Option Name	Available Settings
Clear high score table	No ◀ Yes
Game difficulty	Easy Medium ◀ Hard Difficult
Credits to start/credits to continue	1/1 ◀ 2/1 2/2
Number of continuations	4 5 6 Unlimited number ◀
Automatic high score re-set after 200 games	Yes ◀ No
Music in attract mode	Yes ◀ No
Rally 50 contest enabled	Yes ◀ (U.S. and Canada only) No (Europe only)
Demo/play mode	Playable game mode ◀ Demonstration mode (players cannot crash)
Restore factory options	Yes No ◀

◀ *Manufacturer's recommended settings*

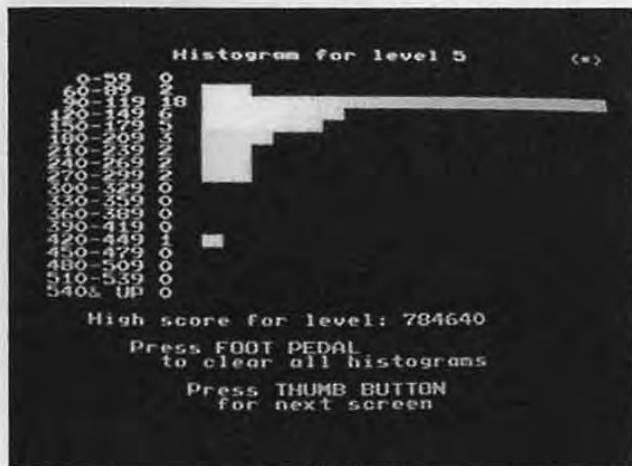

Figure 2-7 Histograms

Press the thumb button to obtain the next screen.

Playfield Test

The Playfield Test screen is shown in Figure 2-8. This screen indicates the condition of some of the graphics ROM, and the vertical and horizontal playfield scrolling registers.

Move the RTC steering control to the left, and the playfield should slowly scroll to the left. Move the RTC steering control right, and the playfield should scroll right. Pressing the trigger button causes the RTC steering control to scroll the playfield up/down when the RTC control is moved left/right.

Press the thumb button to obtain the next screen.

Control Test

The Control Test screen is shown in Figure 2-9. This screen indicates the condition of the controls, graphics ROMs, and motion object circuitry. Moving the RTC steering control to the left and right will change the dis-



Figure 2-8 Playfield Test



Figure 2-9 Control Test

played value next to the word *STEERING*: (the left number is in decimal, the right one is in hexadecimal). Look for consistent readings (within ± 2) when you move the control to its left and right limits.

The *FOOT PEDAL*: message also displays decimal (left) and hexadecimal (right) values. Look for a difference of at least 64 between the fully pressed and fully upright positions of the foot pedal. These values should increase as the pedal is pressed.

Also note that the player's car should be displayed in the center pointing ahead, as in game play. Another vehicle is displayed (initially a stinger) at the top of the roadway in the left lane.

Moving the RTC steering control to the left or right while holding down the triggers selects a different opponent; moving the RTC steering control to the left or right steps that opponent through the next lane on the left or right. Finally, pressing the foot pedal moves the vehicle down the screen towards the bottom. Eventually the opponents will disappear as they move outside the display window.

Motion Object Test

The Motion Object Test indicates the condition of the motion-object buffer circuit. The seven groups of eight motion objects should be identical and eight pixels high.

Press the trigger button to select one of the 56 motion objects. RTC left/right movement moves an object left/right. The object should be invisible about half the distance of its travel (for about five seconds). Pressing the trigger switch causes the RTC steering control left/right movement to move the object up/down. (Figure 2-10 shows the screen after some motion objects have been moved.)

Press the thumb button to obtain the next screen.

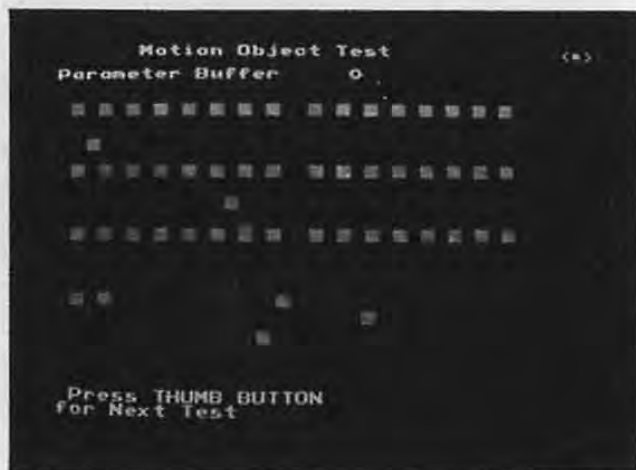

Figure 2-10 Motion Object Test

Motion Object Height Test

The Motion Object Height Test indicates the condition of the motion object/playfield graphic address generator circuit.

Each successive column of motion objects should be eight pixels taller than the last. The top eight pixels of all the columns should be the same. The top 16 pixels of all the columns that are at least 16 pixels high should be the same. Each column should add a new 8×8 pixel stamp picture to the bottom and slide the old picture up by eight pixels. The motion objects can be moved by following the same procedure as in the Motion Object Height Test. (Figure 2-11 shows the screen after some motion objects have been moved.)

Press the thumb button to obtain the next screen.

Alphanumerics Test

The Alphanumerics Test screen is shown in Figure 2-12. This test indicates the condition of the alphanumerics circuit.

Press the thumb button to obtain the next screen.

Color Test

The Color Test screen is shown in Figure 2-13. This test indicates the condition of the display color circuits.

There should be eight vertical grey-scale bars and three groups of eight horizontal bars with shades of red, green, and blue. The brightest bars should be on the left, and the darkest (black) bars should be on the right. A bright white frame should surround the screen: this frame will help to identify the darkest color band. If the display characteristics are not correct, refer to the display manual for the color-gun adjustment procedure or to determine the possible cause of failure.



Figure 2-11 Motion Object Height Test



Figure 2-12 Alphanumerics Test



Figure 2-14 Color Purity Test

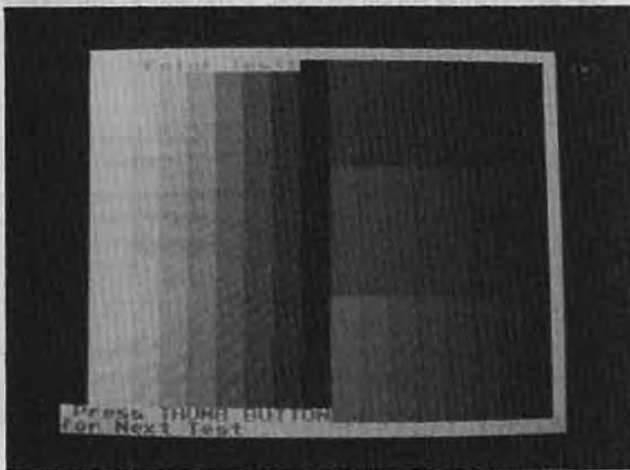

Figure 2-13 Color Test

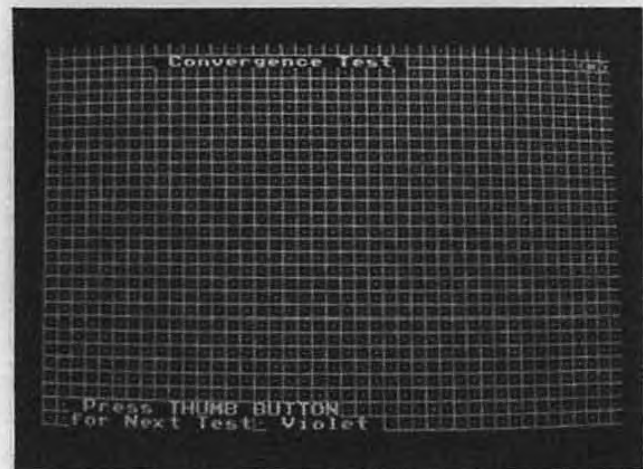

Figure 2-15 Convergence Test

Press the thumb button to obtain the next screen.

Color Purity Test

The Color Purity Test consists of five color displays that indicate the condition of the display color-purity circuits. The first display to appear should be a red screen with the word *RED* displayed at the bottom of the screen.

Press the foot pedal and the next display to appear should be green with the word *GREEN* displayed at the bottom of the screen (see Figure 2-14). Press the foot pedal to obtain a blue, white, and finally a grey screen. After the grey screen the software repeats the cycle, beginning with the red screen.

If the display characteristics are not correct, refer to the video display manual for the color-purity adjustment procedure or the possible cause of failure.

Press the thumb button to obtain the next screen.

Convergence Test

The Convergence Test screen is shown in Figure 2-15. This test indicates the condition of the display size, centering, linearity, and convergence. The grid pattern should be white.

Press the foot pedal, and the pattern should turn violet. Repeated pressing of the foot pedal should cause the screen to alternate between violet and white. Check the grid pattern for the following characteristics (the violet and white patterns are used to adjust the display convergence):

- The four corners of the frame around the grid pattern should touch all four corners of the screen.
- Grid lines should exhibit no pincushioning or barreling, and the lines should be straight within 3 mm.
- Violet and white pattern convergence should be within 2 mm.

If the display characteristics are not within these limits, refer to the display manual for the linearity and convergence adjustment procedures or to determine the possible cause of failure.

Move the RTC steering control left/right, and the pattern should slowly move left/right. Moving the RTC steering control left or right with the trigger switch depressed should cause the pattern to scroll up or down.

Press the thumb button to obtain the next screen.

Sound Test

The Sound Test screen is shown in Figure 2-16. This test indicates the condition of the coin mechanisms, and the music and sound-effects circuits.

The sound microprocessor is reset at the beginning of this test; the reset can take several seconds. If the sound-mi-

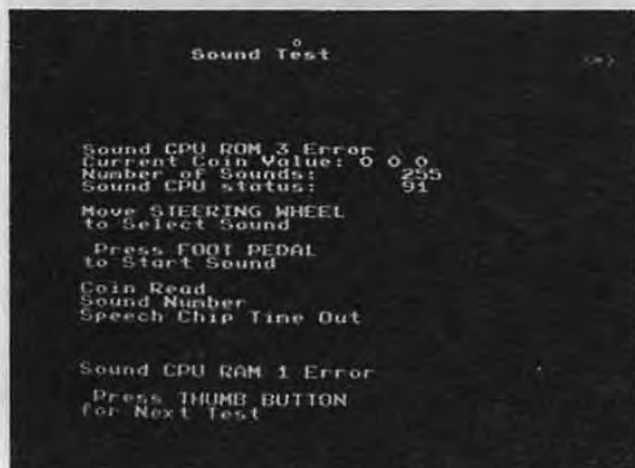

Figure 2-16 Sound Test

croprocessor reset fails, the message *SOUND PROCESSOR NOT RESPONDING* should flash near the top of the screen. Move the RTC steering control left with the trigger switch pressed to sequence forward through the sounds; move the RTC steering control right with the trigger switch pressed to sequence backwards. Press the foot pedal to start the selected sound. The Sound Test provides the following sound information:

- *Current Coin Value* consists of three zeros. As coins are deposited in each of the coin mechanisms, the second and third zero should change to a 1 as the coin switch is held down and should change back to zero when the coin switch is released.
- *Number of Sounds* indicates the number of sounds used in the Road Blasters game.
- *Sound CPU Status* indicates the condition of the sound microprocessor. If the sound microprocessor is good, the word *Good* should appear. If the sound microprocessor is faulty, the message *Sound CPU ROM 1, ROM 2, or ROM 3 Error* appears at the top of the screen.

Error Message	Location on Cartridge 3 and 4 PCB Assemblies
ROM 1	14E
ROM 2	15/16E
ROM 3	17E

- *Music Chip Test* consists of eight tones in a major scale that alternate between sound channels (16 tones in all).
- *Effects Chip Test* consists of four tones in a major chord that come from both sound channels simultaneously.
- *Speech Chip Test* consists of a synthesized voice repeating the message "speech chip test."

Press the thumb button to obtain the first screen (the RAM/ROM Test).

Preventive Maintenance

Chapter 3

Maintenance

This chapter includes preventive and corrective maintenance procedures for the Road Blasters™ game components that are subject to the most use. To assure maximum trouble-free operation from this game, we recommend that preventive maintenance be performed as described in this chapter.

Removal, disassembly, reassembly, and replacement procedures are provided for components that might require corrective maintenance. Appropriate references are provided to Chapter 5, Illustrated Parts Lists, to help locate the parts of this game that are mentioned, but not illustrated, in the maintenance procedures.

NOTE

All Road Blasters game kits use an RTC steering control assembly that is different from the one shown in this chapter. Refer to the supplement CO-298-01 for the appropriate drawing, parts list, and maintenance procedures.



Preventive Maintenance

Preventive maintenance includes cleaning, lubricating, and tightening hardware. How often preventive maintenance is performed depends upon the game environment and frequency of play. We recommend that preventive maintenance be performed at the intervals specified.

Preventive-Maintenance Intervals

The preventive-maintenance intervals are the recommended minimum requirements for the components listed.

⚠ WARNING ⚠

To avoid possible electrical shock, turn off the game before performing any maintenance procedures.

The 5-volt switching power supply for this game does not have a shield. This power supply has high voltages on it when power is turned on. Therefore, be sure you *do not touch this power supply* unless you have turned off the power to the game.

- | | |
|------------------------|---|
| • RTC Steering Control | Inspect weekly, lubricate, and tighten hardware at least every three months. Also, inspect the handle microswitches weekly. |
| • Foot Pedal | Lubricate and tighten hardware at least every three months. |
| • Coin Mechanism | Inspect whenever coins are collected. Clean at least every three months. |
| • Interior Components | Clean at least every six months. |

Removing the Control Panel

Perform the following procedure to remove/replace the control panel. (See Figure 3-1.)

1. Unlock and open the coin door on the front of the cabinet.
2. Carefully reach through the coin door opening and release the spring-draw latch located under the control panel on the right side of the cabinet.
3. Unlock and remove the front access panel.
4. Carefully reach up under the top of the front access panel opening and release the spring-draw latch located under the control panel on the left side of the cabinet.

5. Use a 1/8-inch hex driver to remove the two screws and washers holding the front of the control panel to the cabinet.
6. From underneath, push up on the front edge of the control panel to free the panel from the slot in the cabinet.
7. Carefully lift the control panel from the cabinet.
8. Disconnect the RTC steering control harness connector from the cabinet control harness.
9. Replace the control panel in the reverse order of removal.

Maintaining the RTC Steering Control

Preventive maintenance on the RTC steering control consists of:

- Inspecting the RTC steering control housing for excessive wear or dirt.
- Checking the operation of all four handle microswitches.
- Inspecting the Optical Coupler PCB Assembly for damage and contamination.
- Lubricating the bronze bearings attached to the control base weldment.
- Replacing or tightening the securing hardware if necessary.

Perform the following procedure to lubricate and tighten the RTC steering control. (See Figure 3-2.)

1. Remove the control panel as previously described.
2. Apply a film of light oil (Atari part no. 107013-001) to the inside and top surfaces of both bronze bearings attached to the inside ends of the control base weldment.
3. Use a 7/16-inch wrench to tighten the nuts holding the RTC steering control to the control panel.

Cleaning the Coin Mechanism

Use a soft-bristled brush to remove loose dust or foreign material from the coin mechanism. A toothbrush may be used to remove any stubborn build-up of residue in the coin path. After cleaning the coin mechanism, blow out all of the dust with compressed air.

Cleaning the Interior Components

Perform the following procedure to clean the components inside the cabinet.

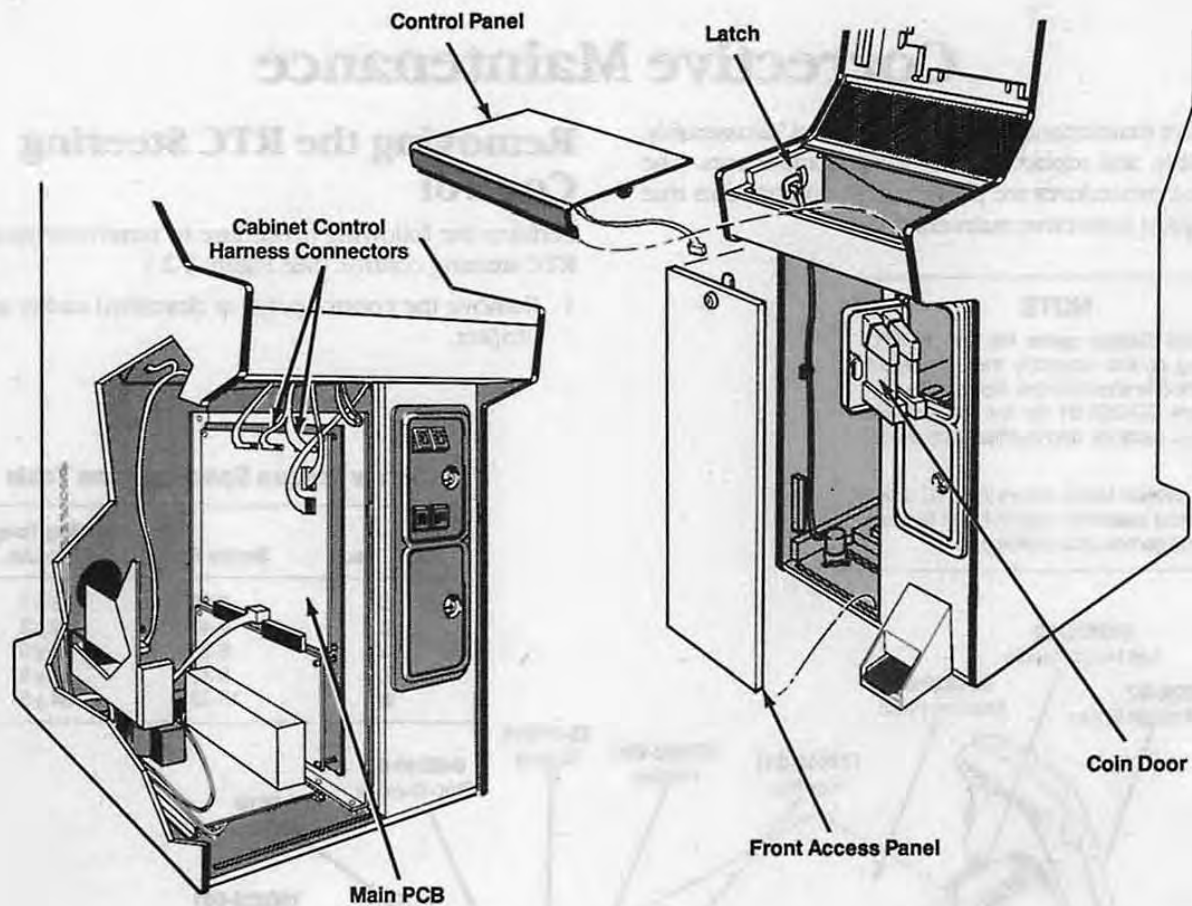

Figure 3-1 Control Panel Removal

⚠ WARNING ⚠

Turn off the game power, and be sure that the on/off switch cover is in place. However, do not unplug the power cord before cleaning inside the cabinet. The power cord provides a ground path for stray static voltages that can be present on the cleaning tools.

1. Unlock and remove the front access panel from the cabinet.
2. Use a Phillips screwdriver to remove the six screws holding the display access panel to the top rear of the cabinet.
3. Discharge the high-voltage from the cathode-ray tube (CRT) before proceeding. The display assembly contains a circuit for discharging the high voltage to ground when power is removed. However, to make certain, always discharge the display as follows.
 - a. Attach one end of a large, well-insulated, 18-gauge jumper wire to ground.

- b. Momentarily touch the free end of the grounded jumper to the CRT anode by sliding it under the anode cap.
- c. Wait two minutes and repeat part b.

CAUTION

Be extremely careful when cleaning the electrical components inside the cabinet. Avoid touching the electrical components with any solid object other than the soft bristles of the vacuum attachment or paint brush.

4. Use a vacuum cleaner with a soft long-bristled brush attachment or use a soft-bristled paint brush to remove loose dirt and dust accumulated on the inside of the cabinet. Be sure to clean the electrical components thoroughly (power supplies, PCB assemblies, display, etc.).

Corrective Maintenance

Corrective maintenance consists of removal, disassembly, reassembly, and replacement of game components. The following procedures are provided for components that may require corrective maintenance.

NOTE

All Road Blasters game kits use an RTC steering control assembly that is different from the one shown below. Refer to the supplement CO-298-01 for the appropriate drawing, parts list, and maintenance procedures.

The illustration below shows the RTC steering control assembly used in Road Blasters System I games and cockpit games.

Removing the RTC Steering Control

Perform the following procedure to remove/replace the RTC steering control. (See Figure 3-2.)

1. Remove the control panel as described earlier in this chapter.

Screw Torque Specifications Table

Ref. No.	Screw Size	Seating Torque Inch-Lbs.
①	2-56	3 ± 1
②	4-40	12 ± 3
③	6-32	28 ± 5
④	8-32	32 ± 5
⑤	10-32	64 ± 5

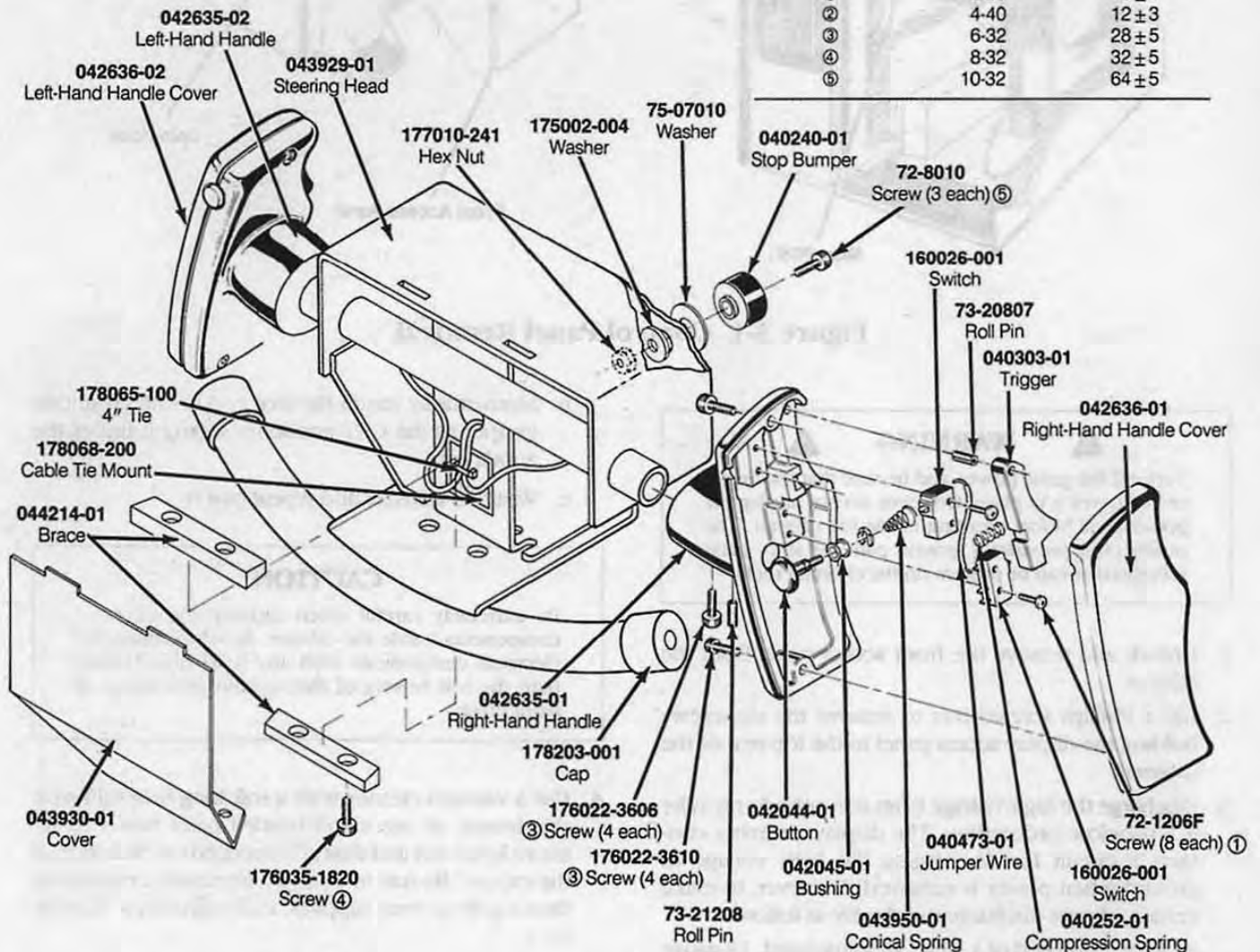

Figure 3-2 RTC Steering Control Disassembly and Lubrication

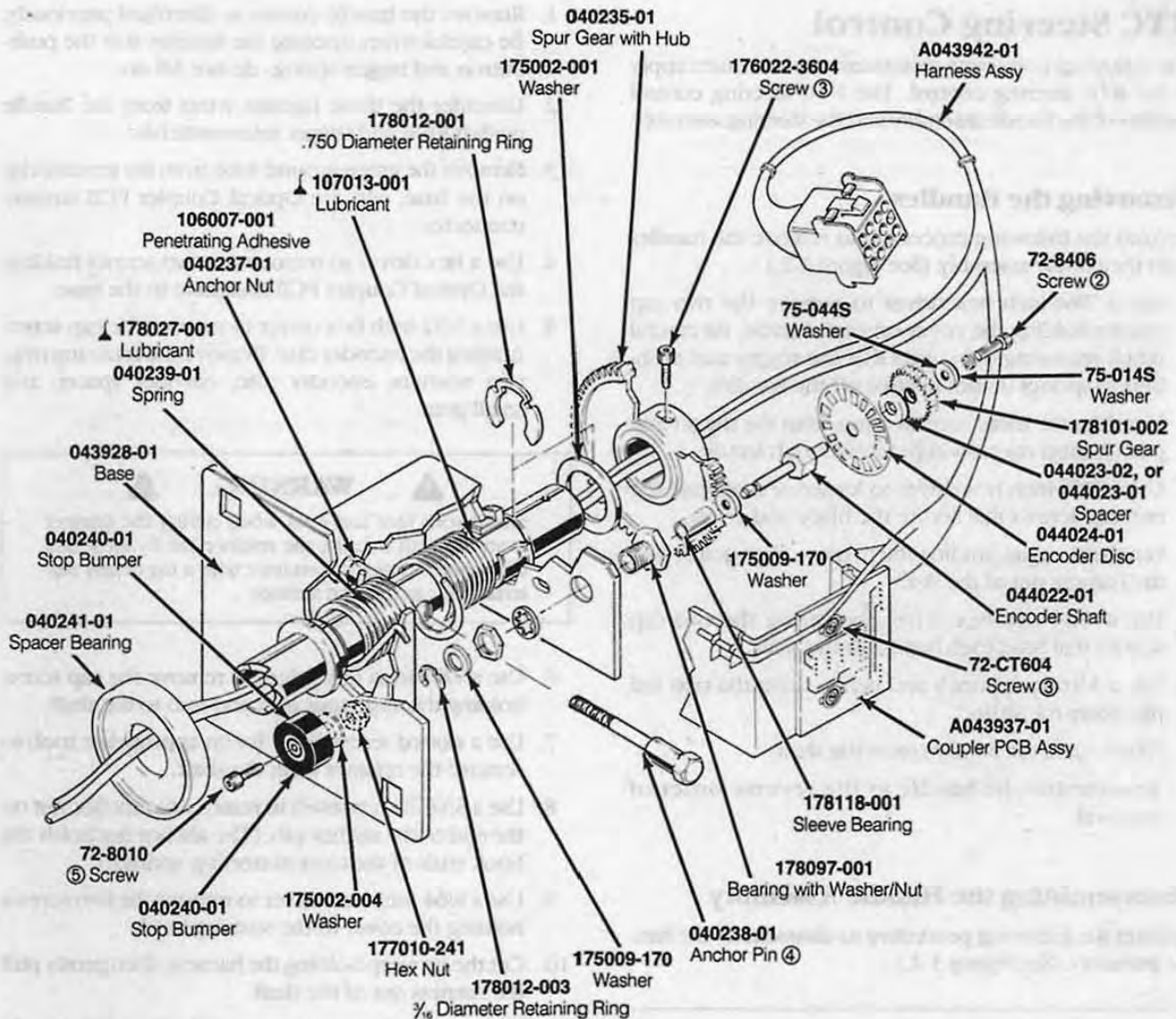

Figure 3-2 RTC Steering Control Disassembly and Lubrication, Continued

2. Use a 7/16-inch wrench to remove the nuts holding the RTC steering control to the control panel.
3. Carefully guide the RTC steering control through the hole in the control panel.
4. Disconnect the RTC steering control harness connector inside the cabinet.
5. Replace the RTC steering control in the reverse order of removal. Be sure to reconnect the control harness connector and the Coupler PCB Assembly harness connector. Also be sure that the RTC harness wires do not interfere with the gears when the control is installed.

NOTE

Certain corrective maintenance procedures can be performed with the RTC steering control attached to the control panel. However, for convenience and to avoid damaging the control panel, we recommend that the RTC steering control be removed from the control panel before any maintenance or repair is performed.

RTC Steering Control

The following corrective maintenance procedures apply to the RTC steering control. The RTC steering control consists of the handle assembly and the steering assembly.

Removing the Handles

Perform the following procedure to remove the handles from the handle assembly. (See Figure 3-2.)

1. Use a 7/64-inch hex driver to remove the two cap screws holding the cover on each handle. Be careful when removing the covers that the trigger and push-button springs do not fall free off the handles.
2. Unsolder the three harness wires from the trigger and push-button microswitches inside each handle.
3. Use a 9/64-inch hex driver to loosen and remove the two cap screws that secure the brace and cover.
4. Cut the tie wrap holding the harness, then gently pull the harness out of the shaft.
5. Use a 7/64-inch hex driver to remove the two cap screws that hold each handle to the shaft.
6. Use a 3/16-inch punch and gently drive the two roll pins from the shaft.
7. Gently slide the handles from the shaft.
8. Reassemble the handle in the reverse order of removal.

Disassembling the Handle Assembly

Perform the following procedure to disassemble the handle assembly. (See Figure 3-2.)

NOTE

Removing the handle assembly from the steering assembly is not necessary to perform the following disassembly procedure. However, refer to *Disassembling the Steering Assembly* later in this chapter for the procedure describing how to separate the two assemblies.

1. Use a 7/64-inch hex driver to remove the two cap screws from each handle assembly cover.
2. Remove the handles as previously described.
3. Replace the handle assembly in the reverse order of removal. Be sure to install a new tie wrap to hold the harness.

Disassembling the Steering Assembly

Perform the following procedure to disassemble the steering assembly. (See Figure 3-2.)

1. Remove the handle covers as described previously. Be careful when opening the handles that the push-button and trigger springs do not fall out.
2. Unsolder the three harness wires from the handle push-button and trigger microswitches.
3. Remove the green ground wire from the ground clip on the base, and the Optical Coupler PCB harness connector.
4. Use a hex driver to remove the two screws holding the Optical Coupler PCB Assembly to the base.
5. Use a 3/32-inch hex driver to remove the cap screw holding the encoder disc. Remove the retaining ring, two washers, encoder disc, encoder spacer, and small gear.

WARNING

Shield your face and eyes when prying the retainer from the shaft because the retainer can fly loose at a high speed. Cover the retainer with a rag or any material that can trap the retainer.

6. Use a 7/64-inch hex driver to remove the cap screw holding the large spur gear and hub to the shaft.
7. Use a slotted screwdriver (or an appropriate tool) to remove the retainer from the shaft.
8. Use a 5/16-inch wrench to remove the anchor nut on the end of the anchor pin. (The anchor nut holds the hook ends of the torsion-steering springs.)
9. Use a 9/64-inch hex driver to remove the two screws holding the cover to the steering head.
10. Cut the tie wrap holding the harness, then gently pull the harness out of the shaft.
11. Gently pull the steering assembly from the handle assembly. Make sure the harness wires are free to slide out of the handle-assembly shaft.
12. Use a 5/32-inch hex driver and 3/8-inch combination wrench to remove the two bumpers from the frame.

NOTE

With the steering control disassembled, lubricate the bronze bearing surfaces, and the torsion springs. Also, apply penetrating adhesive inside the anchor nut hole after assembly. Refer to *Maintaining the RTC Steering Control* earlier in this chapter for further information.

13. Reassemble the steering assembly in the reverse order of removal. Be sure that all necessary screws have been tightened according to the Screw Torque Specifications Table. (See Figure 3-2.)

Installing the Harness Assembly

Perform the following procedure to install the harness assembly to the RTC steering control. (See Figure 3-2.)

1. If necessary, remove the handle covers as described under *Removing the Handles*.
2. Guide the harness wires into the spur-gear end of the hollow steering-assembly shaft. The wire routing on both microswitches should be as follows:

C = Common, should be the black wire. The black wire can go to either C (common) switch tab as long as there is a jumper wire.

NO = Normally open (Thumb Button), should be the red wire.

NO = Normally open (Trigger Button), should be the white wire.

NOTE

The tab locations are identical on both microswitches. However, because one microswitch is upside down, the markings are not visible.

3. Route and solder the wires to the microswitches. Note that either wire bundle can go to either handle.
4. Install the wire tie, optical coupler PCB connector, and the ground clip. Make sure the wires do not interfere with the gears when the steering control is mounted.

Removing the Video Display

Perform the following procedure to remove/replace the video display. (See Figure 3-3.)

1. Turn the game power off and wait two minutes. Unplug the power cord.
2. Use a Phillips screwdriver to remove the two screws holding the lower retainer to the cabinet.
3. Grasp the display shield on the bottom edge and gently pull it out about a half-inch from the cabinet.
4. Gently lower the display shield to free it from the grooved molding under the attraction panel.
5. Use a flat-head screwdriver to remove the staples, if any, securing the bezel to the cabinet.
6. Remove the bezel.
7. Use a Phillips screwdriver to remove the six screws holding the upper rear access panel to the cabinet.

⚠ WARNING ⚠

High Voltage

The video display contains lethal high voltages. To avoid injury, do not attempt to service this display until you observe all precautions necessary for working on high-voltage equipment.

X-Radiation

The video display has been designed to minimize X-radiation. However, to avoid possible exposure to soft X-radiation, *never* modify the high-voltage circuitry.

Implosion Hazard

The cathode-ray tube may implode if struck or dropped. Shattered glass may cause injury within a 6-foot radius. Use care when handling the display.

8. Discharge the high-voltage from the cathode-ray tube (CRT) before proceeding. The display assembly contains a circuit for discharging the high voltage to ground when power is removed. However, to make certain, always discharge the display as follows.
 - a. Attach one end of a large, well-insulated, 18-gauge jumper wire to ground.
 - b. Momentarily touch the free end of the grounded jumper to the CRT anode by sliding it under the anode cap.
 - c. Wait two minutes and repeat part b.
9. From the back of the cabinet, unplug the display harness connectors and disconnect the green ground wire from the clip on the video display chassis.

⚠ WARNING ⚠

To avoid dropping the video display out of the game cabinet, use extreme care when removing the display-mounting nuts. We recommend that a second person *carefully* hold the display chassis from the back of the cabinet while the mounting nuts are being removed.

10. From the front of the cabinet, use a 3/8-inch wrench to remove the four nuts and flat washers securing the display to the cabinet.
11. Carefully slide the display out through the front of the cabinet.
12. Replace the video display in the reverse order of removal.

NOTE

Whenever the cathode-ray tube is replaced, readjust the brightness, purity, and convergence as described in the display manual.

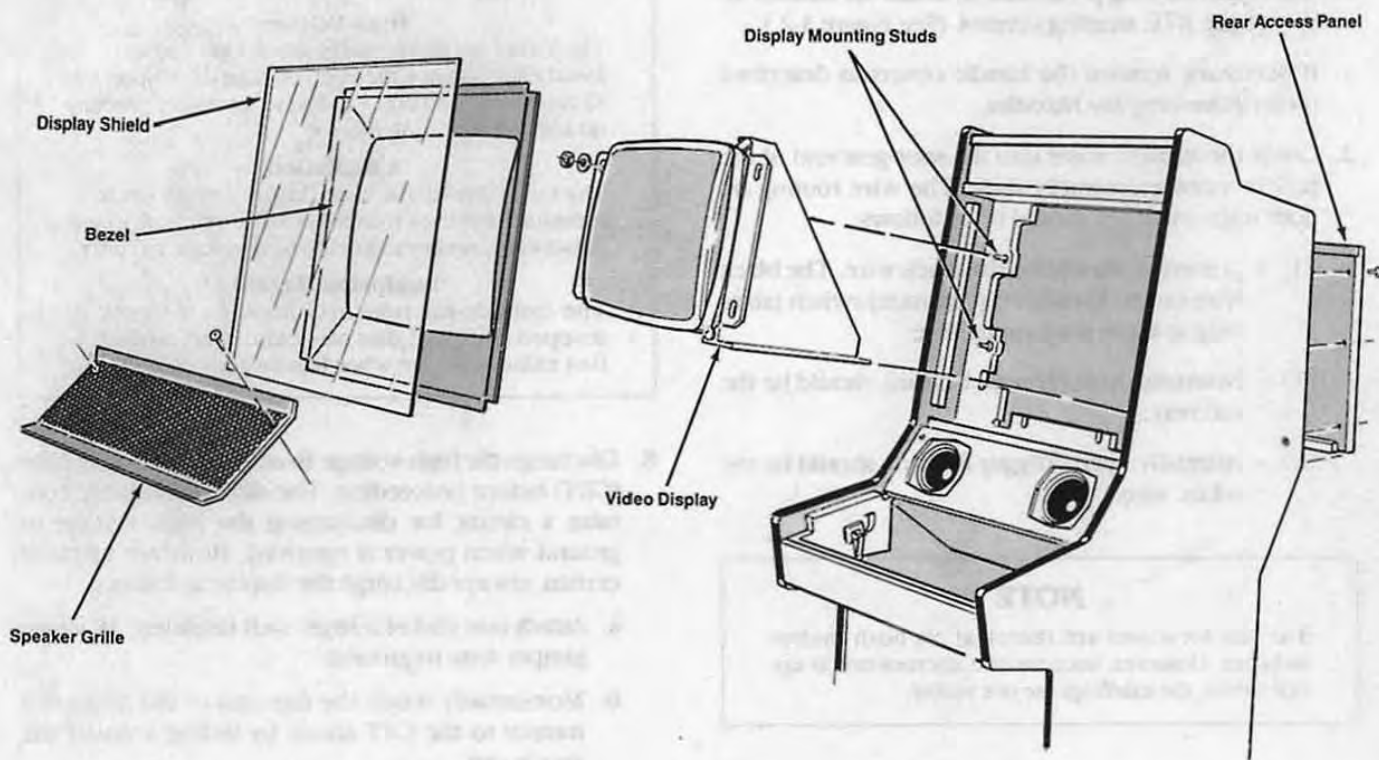

Figure 3-3 Video Display Removal

Removing the Foot Pedal Control

Perform the following procedure to remove/replace the foot pedal control.

1. Disconnect the foot pedal harness assembly from the cabinet control harness assembly located inside the lower coin door.
2. From the inside of the cabinet, use a 7/16-inch hex driver to remove the nuts and washers from the four bolts holding the foot pedal frame to the front of the cabinet.

Removing the Main PCB

Perform the following procedure to remove/replace the main PCB. (See Figure 3-4.)

NOTE

The procedure for removing the Cartridge PCB is included in the Kit Installation chapter of this manual.

1. Turn the cabinet power off.
2. Unlock and remove the front access panel from the cabinet.
3. Disconnect the harness connectors from the Main PCB.
4. Use a Phillips screwdriver to remove the four screws securing the ground plane to the cabinet.
5. Carefully remove the ground plane, with the PCB(s) attached, and place on a clean surface.
6. Use a Phillips screwdriver to remove the six screws securing the Main PCB to the ground plane.
7. Gently disconnect the Main PCB from the Cartridge PCB.
8. Replace the Main PCB in the reverse order of removal. Make sure that the Main PCB is fully inserted into the Cartridge PCB edge connectors and the ground strap is properly connected to the ground plane. See Figure 5-1 for the ground strap and harness connector locations.

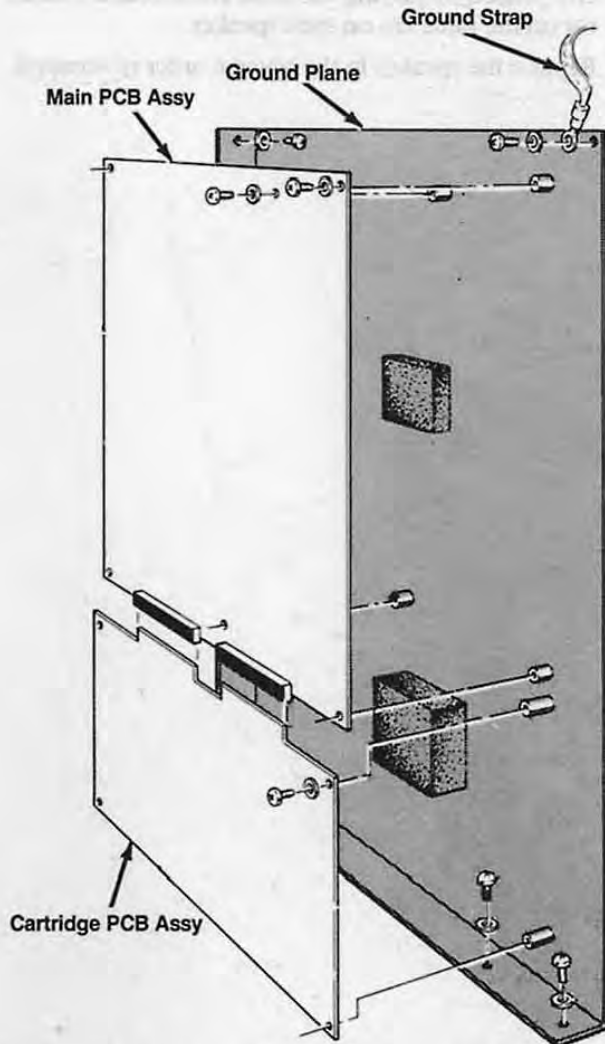

Figure 3-4 Main PCB Removal

Removing the Fluorescent Light Assembly

Perform the following procedure to remove/replace the fluorescent light assembly. (See Figure 3-5.)

1. Turn the game power off.
2. From the rear of the cabinet, use a Phillips screwdriver to remove the six screws securing the upper rear access panel to the cabinet.
3. Disconnect the fluorescent-light harness connector.
4. From the front of the cabinet, use a 1/8-inch hex driver to remove the three screws and washers securing the upper retainer to the top of the cabinet.
5. Grasp the top edge of the attraction shield and film and lift out of the cabinet.
6. Gently twist the fluorescent tube a quarter turn and remove from the sockets.

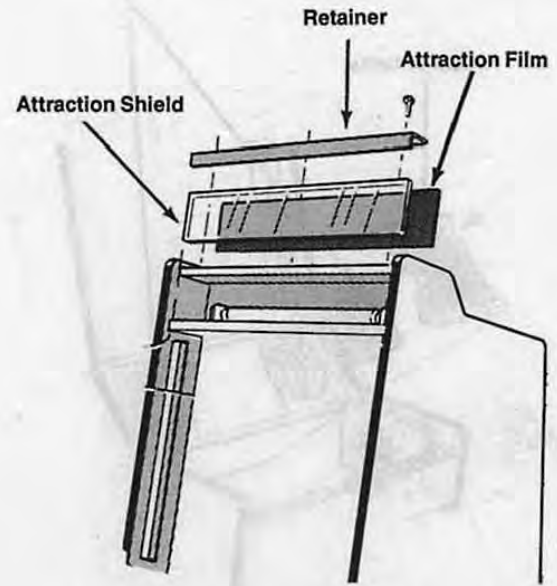

Figure 3-5 Fluorescent Light Assembly Removal

7. Use a Phillips screwdriver to remove the two screws holding the fluorescent light bracket to the cabinet.
8. Lift the fluorescent light assembly out of the front of the cabinet.
9. Replace the fluorescent light assembly in the reverse order of removal.

Removing the Speakers

Perform the following procedure to remove/replace the speakers. (See Figure 3-6.)

1. Remove the control panel as described in *Removing the Control Panel*.
2. Use a Phillips screwdriver to remove the two screws holding the speaker grille to the cabinet. Remove the speaker grille.

CAUTION

Do not touch the speaker cones when handling the speakers. The cone material is fragile and can be easily damaged.

3. Use a Phillips screwdriver to remove the four screws holding the speaker to the cabinet. Do not let the speaker fall.
4. Lower the speaker just far enough to disconnect the two speaker wires. Ensure that the speakers are prop-

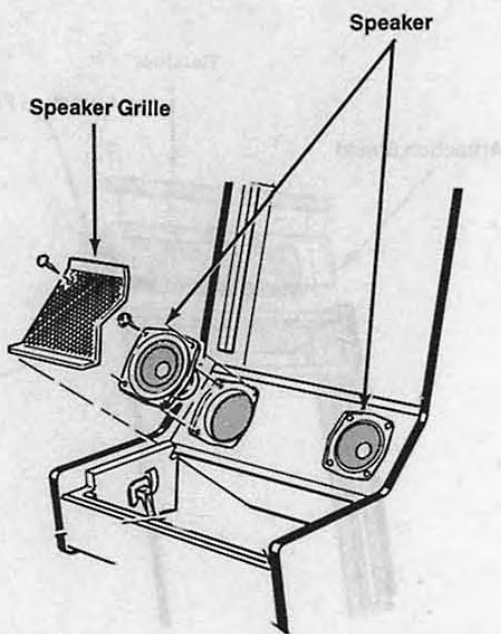

Figure 3-6 Speaker Removal

- erly phased by placing the same color-coded connector on the same tab on each speaker.
- 5. Replace the speaker in the reverse order of removal.



Figure 3-4 Main PCB Removal

7. Use a Phillips screwdriver to remove the screws holding the fluorescent light assembly to the cabinet. Lift the fluorescent light assembly out of the cabinet. Replace the fluorescent light assembly in the cabinet in the reverse order of removal.

Removing the Speakers

Perform the following procedure to remove the speakers (see Figure 3-6).

1. Remove the control panel as described in the wiring manual.
2. Use a Phillips screwdriver to remove the screws holding the speaker grille to the cabinet. Remove the speaker grille.

CAUTION
Do not touch the speaker cone when handling the speaker. The cone is a fragile component and can be damaged.

3. Use a Phillips screwdriver to remove the screws holding the speaker to the cabinet. Do not let the speaker fall.
4. Lower the speaker just far enough to disconnect the two conduct wires. Ensure that the speaker wires are

Removing the Fluorescent Light Assembly

Perform the following procedure to remove/replace the fluorescent light assembly (see Figure 3-5).

1. Turn the main power off.
2. From the rear of the cabinet, use a Phillips screwdriver to remove the six screws securing the cover and separate the cover from the cabinet.
3. Disconnect the fluorescent light fixture connector from the rear of the cabinet and the fluorescent fixture.
4. Remove the three screws and wires securing the light fixture to the top of the cabinet.
5. From the top edge of the enclosure, gently and slowly lift out the cabinet.
6. Connect the fluorescent tube to a ground terminal and remove it from the socket.

Troubleshooting Aids

Troubleshooting aids are provided throughout this manual and the schematic package supplement. The following information is intended to acquaint the service technician with the portions of these documents that contain useful troubleshooting and repair information.

Assembly and Component Locations

The parts lists in Chapter 5 of this manual illustrate the locations of assemblies and components. Printed-circuit board (PCB) illustrations aid in rapidly locating components shown on the corresponding schematic diagram(s).

Diagrams

The schematic package supplement for this manual contains schematic diagrams with component locations, active component type numbers, and electrical values.

Troubleshooting Techniques

⚠ WARNING ⚠

To avoid electrical shock, turn off the game power before attempting to troubleshoot this game.

The following troubleshooting steps are arranged in a sequence recommended for locating a defective component. The procedure begins with a check of the simple trouble possibilities and progresses to more extensive procedures for localizing the problem to an assembly or major circuit, and then to a defective component.

Check Fuses

Check for open fuses. Refer to the power supply parts list in Chapter 5 and to the display manual for the location and rating of each fuse used in this game. Make sure that replacement fuses are the proper type and rating.

Check Power-Supply Voltages

Improper operation of all circuits usually indicates a power supply problem. Be sure that the proper line voltage is available to the power supply. Refer to the label on the power supply for its voltage rating.

Localize Trouble

Determine the trouble symptom. Use the wiring diagrams in the schematic package supplement to determine which assemblies or major circuits could cause the trouble. Perform the self-test procedure provided in Chapter 2 of this manual.

Visual Check

Visually check for obvious problems in the portion of the game where the trouble is suspected. For example, check for loose or defective solder connections, integrated circuits loose in their sockets, loose cable connections, broken wires, and damaged PCBs or components.

Check Individual Components

Check soldered-in passive components (e.g., resistors, capacitors, diodes) by disconnecting one end to isolate the measurement from the effects of the surrounding circuitry. Often, direct substitution is the most practical way to determine if a component is faulty. However, eliminate the possibility of some other circuit problem that could damage the substitute component.

Repair the Assembly

CAUTION

Soldered-in transistors and integrated circuits are difficult to remove without damaging the printed-circuit board or component. Refer to the information in this chapter pertaining to soldering and replacing integrated circuits and transistors.

Repair or replace the defective part. Refer to Chapter 3 and information in this chapter for special removal and replacement procedures. Check for proper operation of the repaired circuit.

Soldering Techniques

Observe the following recommendations when removing or replacing components soldered to a PCB. Poor soldering practices can damage a PCB or heat-sensitive electrical components.

Choosing the proper soldering iron is essential before attempting to remove or replace soldered-in components. Excessive heat is a common cause of damage to a component or PCB. However, transient voltages from solder guns or improperly grounded soldering irons can also damage certain voltage-sensitive semiconductor devices. Refer to *Troubleshooting Static-Sensitive Devices* for more specific information.

A 15- to 27-watt pencil-tip soldering iron is recommended to avoid separating the etched circuit wiring from the board material and to avoid damaging active components. A temperature-controlled soldering station rated at 700°F with a fine cone or a very fine chisel tip can also be used.

CAUTION

Solder guns are *not* recommended for removing or replacing soldered-in components on a printed-circuit board. Solder guns can overheat a device, and their large transient voltage can damage a voltage-sensitive device.

The following additional equipment is recommended for removing and replacing soldered-in components:

- **Solder Sucker**—Hand-operated vacuum tool used to remove liquified solder from the PCB. We recommend the top-of-the-line Soldapull® brand.
- **Solder Wick**—Resin-soaked copper braid used for removing excess solder from the lead connections on the PCB. See *Removing Integrated Circuits* for precautions relating to the use of a solder wick on a multi-layer PCB with plated-through holes.
- **Flux Remover**—Non-corrosive chemical used to clean foreign material from the PCB before soldering and to remove any flux residue where components have been replaced. Also used to clean any foreign material from the PCB during preventive maintenance. Isopropyl alcohol is recommended.
- **Acid Brush**—Small stiff-bristled paint or toothbrush used with flux remover to clean flux and other foreign material from the PCB.

Removing Integrated Circuits

The easiest and safest method for removing soldered-in integrated circuits (IC) from a PCB is to cut off each pin as close to the IC case as possible with a tip dyke (diagonal cutter) as shown in Figure 4-1.

Use the proper soldering iron as previously described under *Soldering Techniques*. Then, to avoid excessive heat buildup in one area of the PCB, apply heat directly to each pin in a random order. Remove the loosened pin with the tip of the soldering iron or a needle-nose pliers as shown in Figure 4-2. Allow a moment for the PCB to cool before proceeding to the next pin. Apply just enough heat to remove any stubborn pins.



Figure 4-1 Removing IC (Cut-Pin Method)

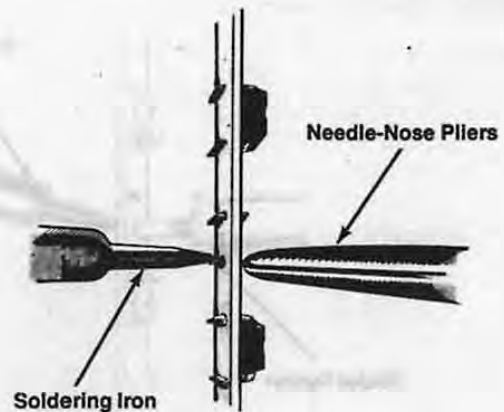

Figure 4-2 Removing IC Pins

For a multi-layer PCB with plated-through holes, use a solder sucker to remove the remaining solder from inside each hole as shown in Figure 4-3. If possible, suck the solder from the opposite side of the PCB from where the heat is applied.

Use a solder wick to remove excess solder from around the lead connection pads on the top and/or bottom surface of the PCB as shown in Figure 4-4.

CAUTION

Do not use a solder wick to remove solder from inside plated-through holes. The heat required for the solder wick to remove the solder from inside the hole could damage the PCB.

Use an integrated-circuit (IC) pulling tool to remove socketed ICs. Do not pry up on one end of the ICs, because the pins could be bent or broken.

Troubleshooting Static-Sensitive Devices

Certain precautions must be taken when working with static-sensitive devices, e.g., microprocessors, field-effect transistors (FET), complementary metal-oxide semiconductors (CMOS), and other large-scale integration (LSI) devices that use metal-oxide semiconductor (MOS) technology. Static charge buildup in a person's body or leakage from an improperly grounded soldering iron can cause static-sensitive device failure.

Before handling a static-sensitive device or a PCB with such devices attached to it, ground any static voltage that may have accumulated in your body by touching an object that has been earth grounded. A bare wire wrapped around your wrist and attached to an earth ground is effective when working extensively with static-sensitive de-

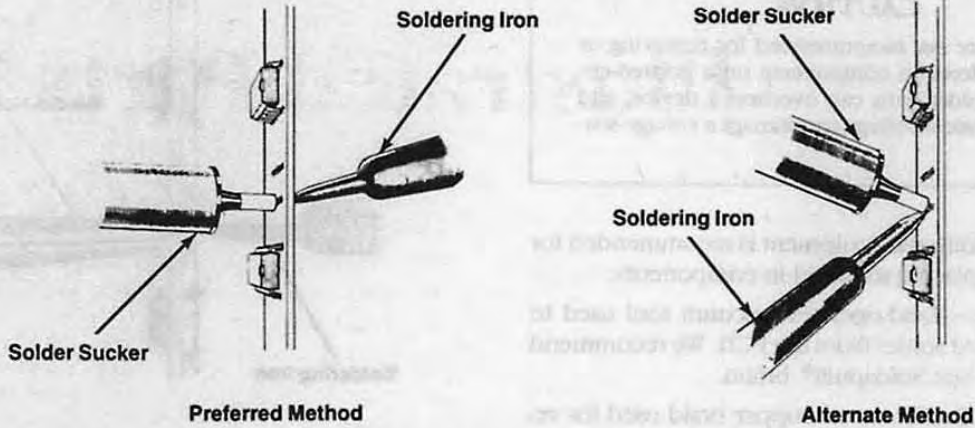

Figure 4-3 Removing Solder from Plated-Through Holes

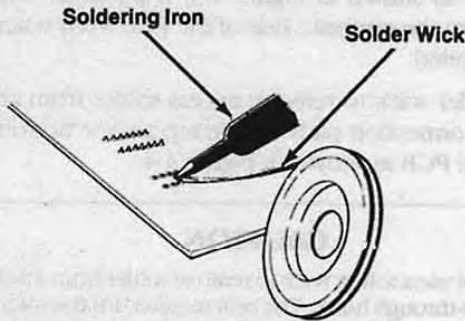

Figure 4-4 Removing Solder from Lead Connection Pads

vices. When soldering a static-sensitive device, use a soldering iron with a properly grounded three-wire cord. (Refer to *Soldering Techniques* for a discussion of recommended soldering irons and procedures.)

A static-sensitive device can appear defective due to leakage on a PCB. Observe the precautions for grounding static voltages described in the preceding paragraph and clean both sides of the PCB with flux remover or an eraser before replacing what can be a good static-sensitive device. For discrete FETs, clean thoroughly between the gate, drain, and source leads.

Static-sensitive devices can be packaged in conductive foam or have a protective shorting wire attached to the pins. Remove the conductive foam just prior to inserting the device into its socket or soldering it to a PCB. Remove the shorting wire only *after* the device is inserted into its socket or *after* all the leads are soldered in place.



Illustrated Parts Lists

This chapter provides information you need to order parts for your game. Common hardware (screws, nuts, washers, etc.) has been deleted from most of the parts lists.

The PCB parts lists are arranged in alphabetical order by component. Each component subsection is arranged alphanumerically by reference designator.

Other parts lists are arranged alphanumerically by Atari part number. In these parts lists, all A-prefix numbers come first. Following these are numbers in sequence evaluated up to the hyphen, namely 00- through 99-, then 000598- through approximately 201000-.

When ordering parts, please give the part number, part name, number of this manual, and serial number of your game. This will help us fill your order rapidly and correctly. We hope the results will be less downtime and more profit from your game.

Atari Customer Service numbers are listed on the inside front cover of this manual.

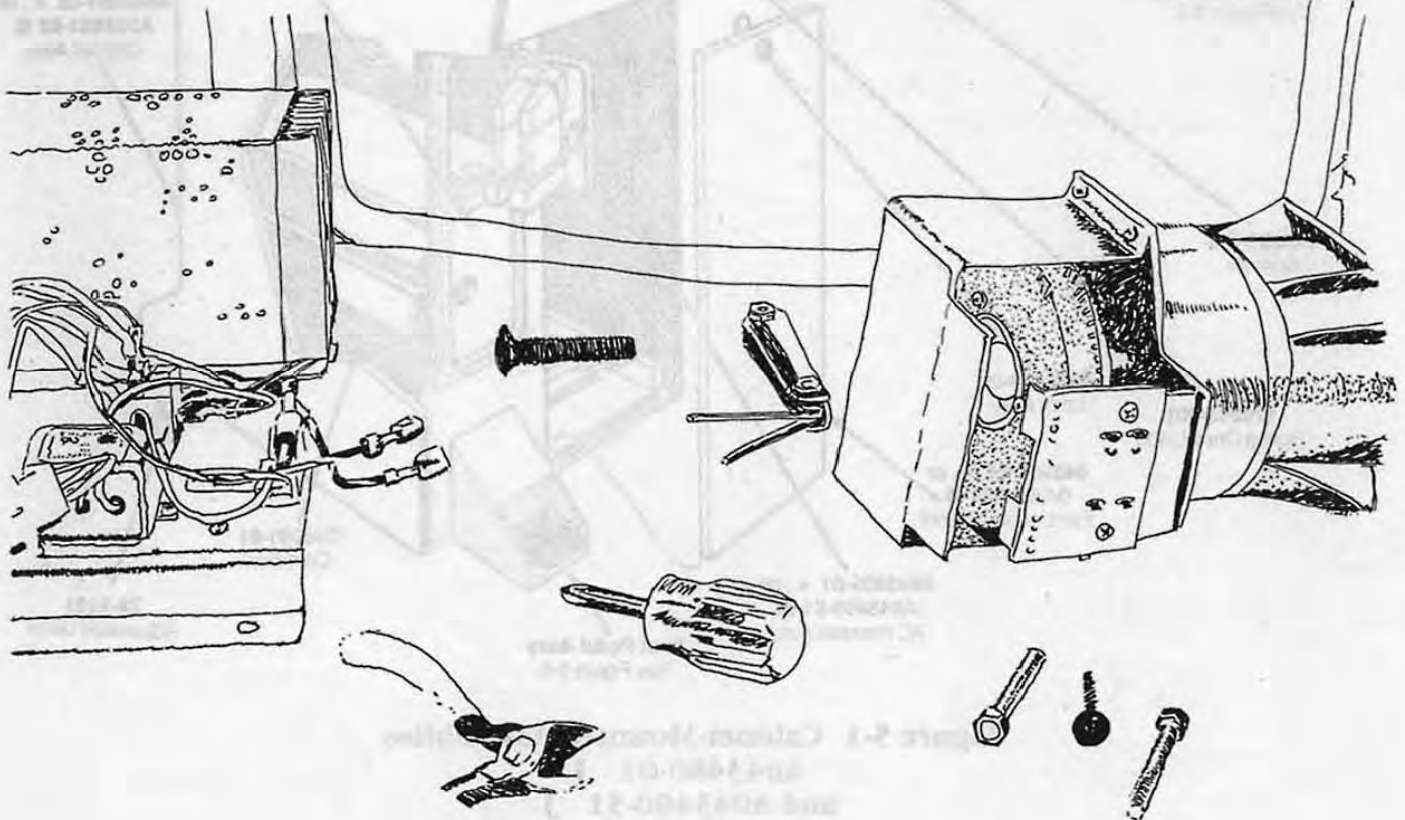

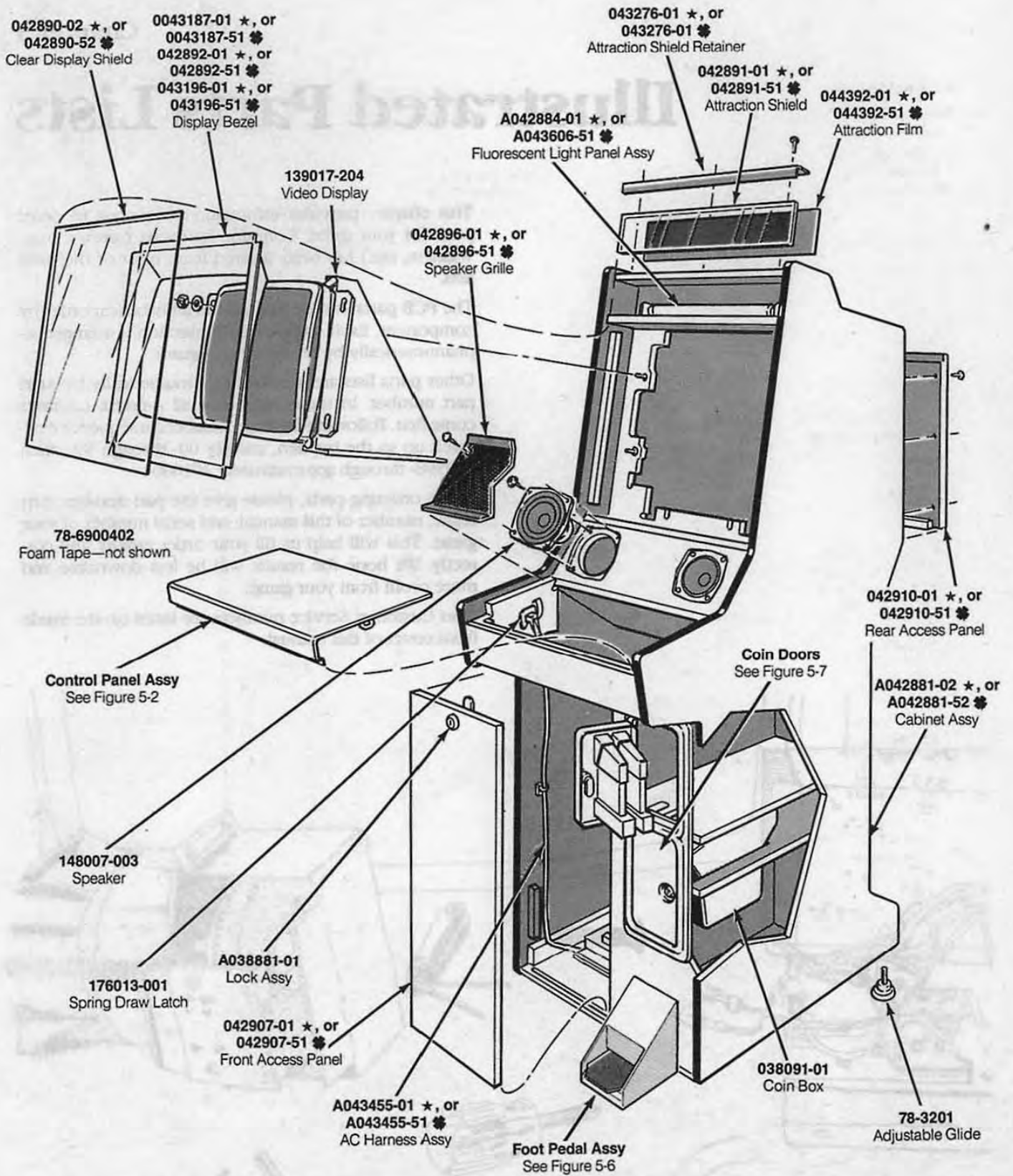

**Figure 5-1 Cabinet-Mounted Assemblies
A043480-01 J
and A043480-51 J**

Items Not Shown
RTC Steering Control Assy
 See Figure 5-3

★ Part used only in US-built cabinets
 ⚙ Part used only in Ireland-built cabinets

**A043941-01 ★, or
 A043941-51 ⚙**
 Cabinet Control Harness Assy

**A043035-01 ★, or
 A043035-51 ⚙**
 Display Harness Assy

**A043456-01 ★, or
 A043456-51 ⚙**
 Coin Harness Assy

**A043086-01 ★, or
 A043086-51 ⚙**
 Ground Strap Assy

**A043457-01 ★, or
 A043457-51 ⚙**
 Speaker Harness Assy

178093-001
 Fan Guard

**A043055-01 ★, or
 A043055-51 ⚙**
 On/Off Switch w/ Harness Assy

Audio II PCB Assy
 See Figure 5-11

171078-002
 Coin Counter

Power Supply Assy
 See Figure 5-5

LSI Main PCB Assy
 See Figure 5-9

**042932-01 ★, or
 042932-51 ⚙**
 PCB Ground Plane Plate

Cartridge PCB Assy
 See Figure 5-10

**A043454-01 ★, or
 A043454-51 ⚙**
 Power Harness Assy

043513-01
 Power Supply Ground Plane Plate

Figure 5-1 Cabinet-Mounted Assemblies, Continued

**A043480-01 J
 and A043480-51 J**

Cabinet-Mounted Assemblies Parts List

Part No.	Description
A03881-01 ★	Lock Assembly
A042881-02 ★	Cabinet Assembly (A042881-52 ☼)
US-Built Fluorescent Light Panel Assembly Only	
A042884-01 ★	Fluorescent Light Panel Assembly—consists of:
A005493-01 ★	Light Harness Assembly
A037540-01 ★	Ground Jumper Assembly
70-304 ★	18-Inch, 15 W, Cool White Fluorescent Tube
72-6408S ★	#4 × ½-Inch Pan-Head Cross-Recessed Tapping Screw
79-561816P ★	Wire Nut
99-11003 ★	Starter
99-11006 ★	Retaining Clip
99-11009 ★	Starter Socket
038151-01 ★	Jumper Wire
041981-01 ★	Lamp Bracket
042920-01 ★	Attraction Glass Panel
142028-001 ★	60 Hz Ballast Transformer
176015-110 ★	#10 × ⅜-Inch Pan-Head Cross-Recessed Deep-Thread Screw
179035-001 ★	Medium Bi-Pin Lamp Holder
Ireland-Built Fluorescent Light Panel Assembly Only	
A043606-51 ☼	Fluorescent Light Panel Assembly—consists of:
A005493-02 ☼	Light Harness Assembly
70-303 ☼	18-Inch, 15 W, Cool White Fluorescent Tube
72-6610S ☼	#6 × ⅞-Inch Pan-Head Cross-Recessed Tapping Screw
79-561816P ☼	Wire Nut
99-11012 ☼	1-Inch Clamp
035835-01 ☼	12-Inch Y-Lead Connector
042920-51 ☼	Attraction Glass Panel
142043-001 ☼	220 V Ballast Transformer
171079-001 ☼	220 V Starter
179220-001 ☼	220 V Starter Socket
A043035-01 ★	Display Harness Assembly (A043035-51 ☼)
A043055-01 ★	On/Off Switch with Harness Assembly (A043055-51 ☼)
A043086-01 ★	Ground Strap Assembly, 8½ Inches Long, attached to LSI Main PCB ground plane plate (A043086-51 ☼)
A043086-03 ★	Ground Strap Assembly, 4½ Inches Long, attached to control panel (A043086-53 ☼)
A043454-01 ★	Power Harness Assembly (A043454-51 ☼)
A043455-01 ★	AC Harness Assembly (A043455-51 ☼)
A043456-01 ★	Coin Harness Assembly (A043456-51 ☼)
A043457-01 ★	Speaker Harness Assembly (A043457-51 ☼)
A043941-01 ★	Cabinet Control Harness Assembly (A043941-51 ☼)
78-3201	Adjustable Glide
78-6900402	¼-Inch × ⅞-Inch Foam Tape (48-inches required; used on control panel and attraction glass)
99-15066	Screw Clamp
038091-01	Molded Coin Box
042890-02 ★	Clear Display Shield (042890-52 ☼)
042891-01 ★	Attraction Shield (042891-51 ☼)
042896-01 ★	Speaker Grille (042896-51 ☼)

Cabinet-Mounted Assemblies Parts List, Continued

Part No.	Description
042907-01 ★	Front Access Panel (042907-51 ☼)
042910-01 ★	Rear Access Panel (042910-51 ☼)
043187-01 ★	Horizontal Display Bezel (043187-51 ☼); Acceptable substitute is part no. 042892-01 ★ (042892-51 ☼)
043196-01 ★	Vertical Display Bezel (043196-51 ☼)
043276-01 ★	Attraction Shield Retainer (043276-51 ☼)
043513-01	Power Supply Ground Plane Plate
044392-01 ★	Attraction Film (044392-51 ☼)
139017-204	Wells-Gardner 19-Inch Standard Resolution Color Raster Video Display, Model 19K7901
148007-003	4½-Inch Round, 8 Ω, 10 W Speaker
171078-002	Non-Resettable Coin Counter, 12 VDC
176013-001	Spring Draw Latch
178093-001	Fan Guard
<i>The following are technical information supplements to this game:</i>	
TM-298	Road Blasters/System I Operators Manual
ST-298	Road Blasters/System I Self-Test Label
SP-298	Road Blasters/System I Schematic Package Supplement
TM-296	Wells-Gardner Model 19K7901 Video Display Service Manual

- ★ Part used only in US-built cabinets
- ☼ Part used only in Ireland-built cabinets

- ★ Part used only in US-built cabinets
- ☛ Part used only in Ireland-built cabinets

78-6900402
Foam Tape-not shown

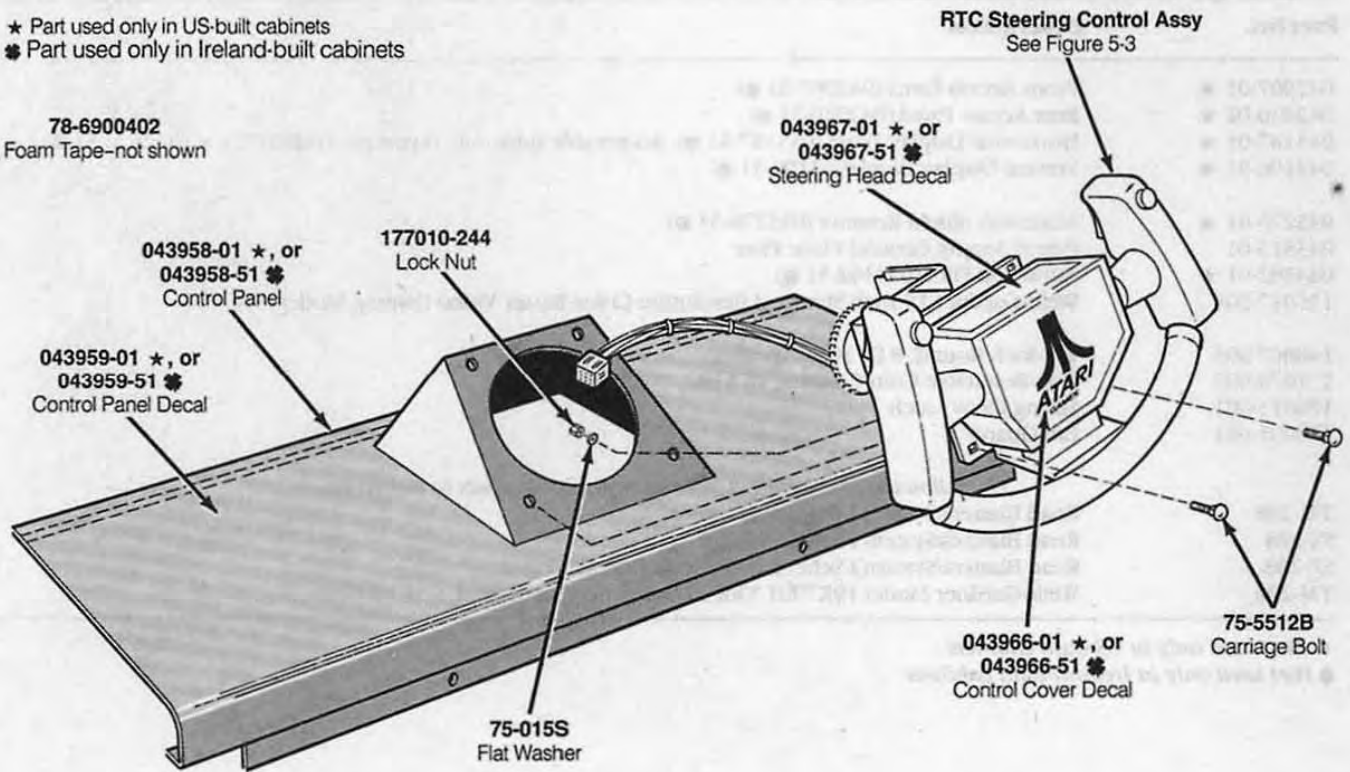

Figure 5-2 Control Panel Assembly
A043957-01 A (US)
and A043957-51 A (Ireland)

Control Panel Assembly
Parts List

Part No.	Description
A043968-01	RTC Steering Control Assembly
75-015S	#1/4 Flat Washer
75-5512B	#1/4-20 x 3/4-Inch Black Carriage Bolt
78-6900402	1/4-Inch x 1/2-Inch Thick Foam Tape
043958-01 ★	Control Panel (043958-51 ☛)
043959-01 ★	Control Panel Decal (043959-51 ☛)
043966-01 ★	Control Cover Decal (043966-51 ☛)
043967-01 ★	Steering Head Decal (043967-51 ☛)
177010-244	#1/4-20 Hex Lock Nut
178082-007	Twist Lock Cable Tie

- ★ Part used only in US-built cabinets
- ☛ Part used only in Ireland-built cabinets

NOTE

All Road Blasters game kits use an RTC steering control assembly that is different from the one shown below. Refer to the supplement CO-298-01 for the appropriate drawing, parts list, and maintenance procedures.

The illustration below shows the RTC steering control assembly used in Road Blasters System I games and cockpit games.

NOTE

After reassembling the RTC steering control, be sure that all necessary screws are properly tightened. See Figure 3-2 for the Screw Torque Specifications Table.

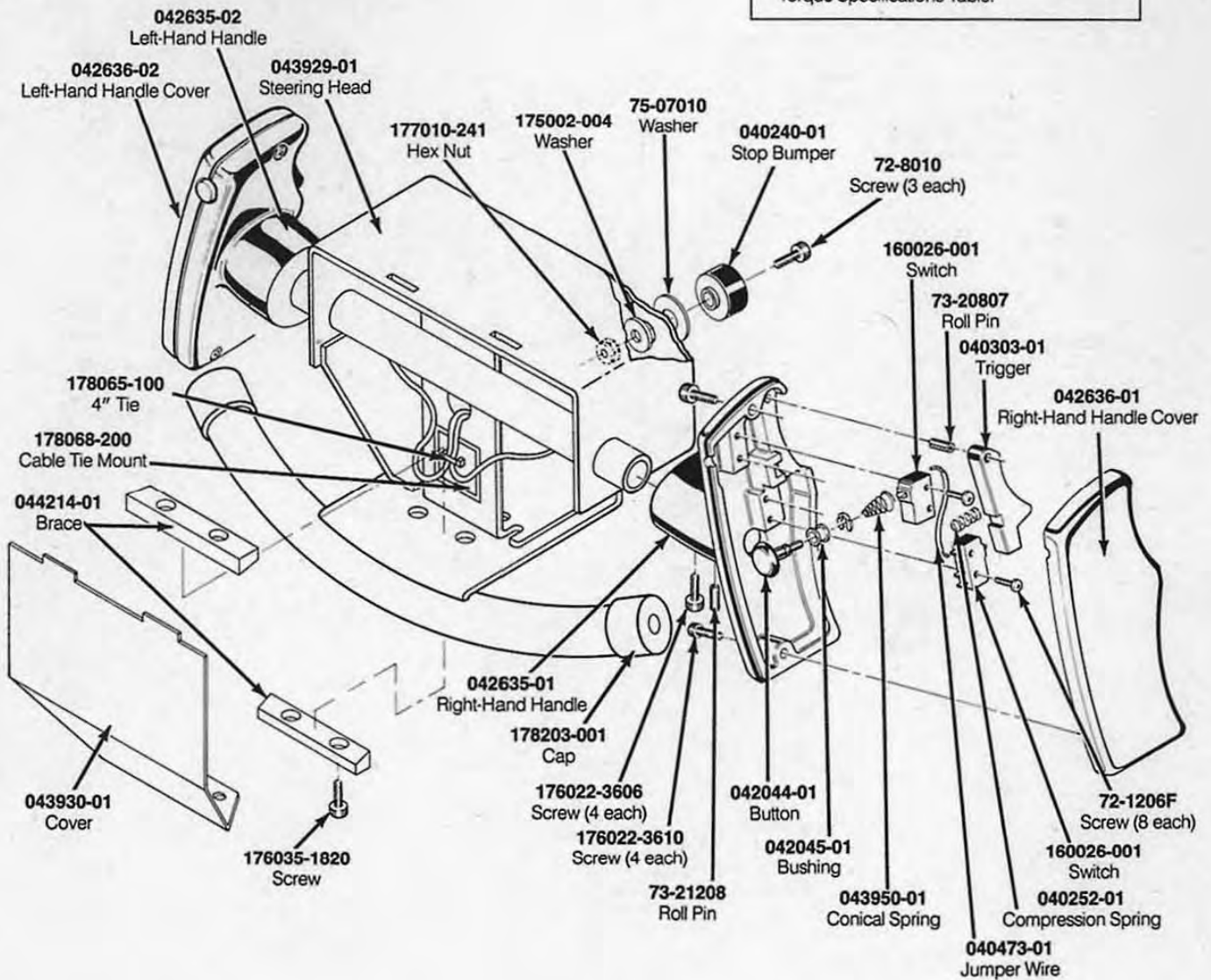

**Figure 5-3 RTC Steering Control Assembly
A043968-01 D**

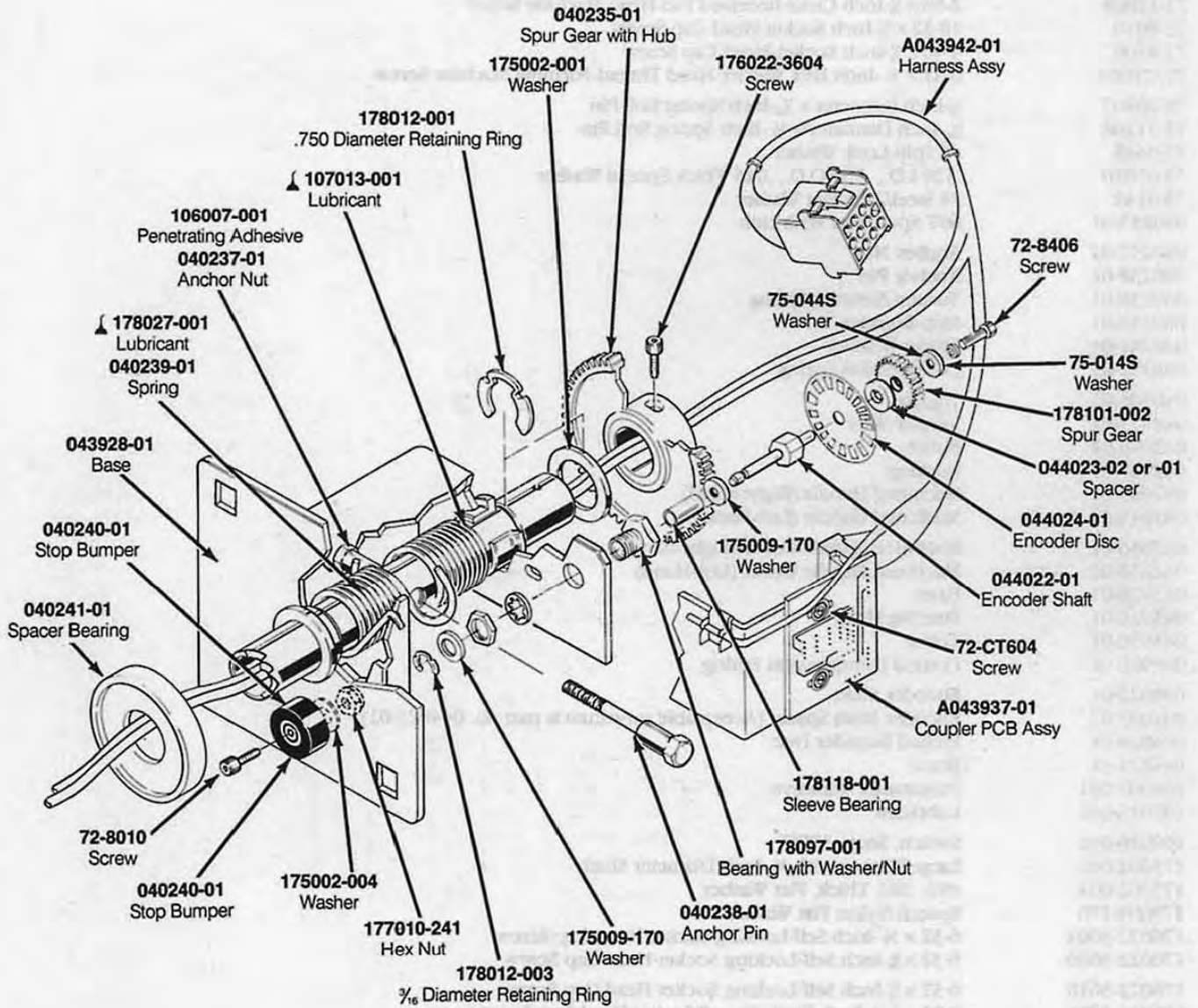
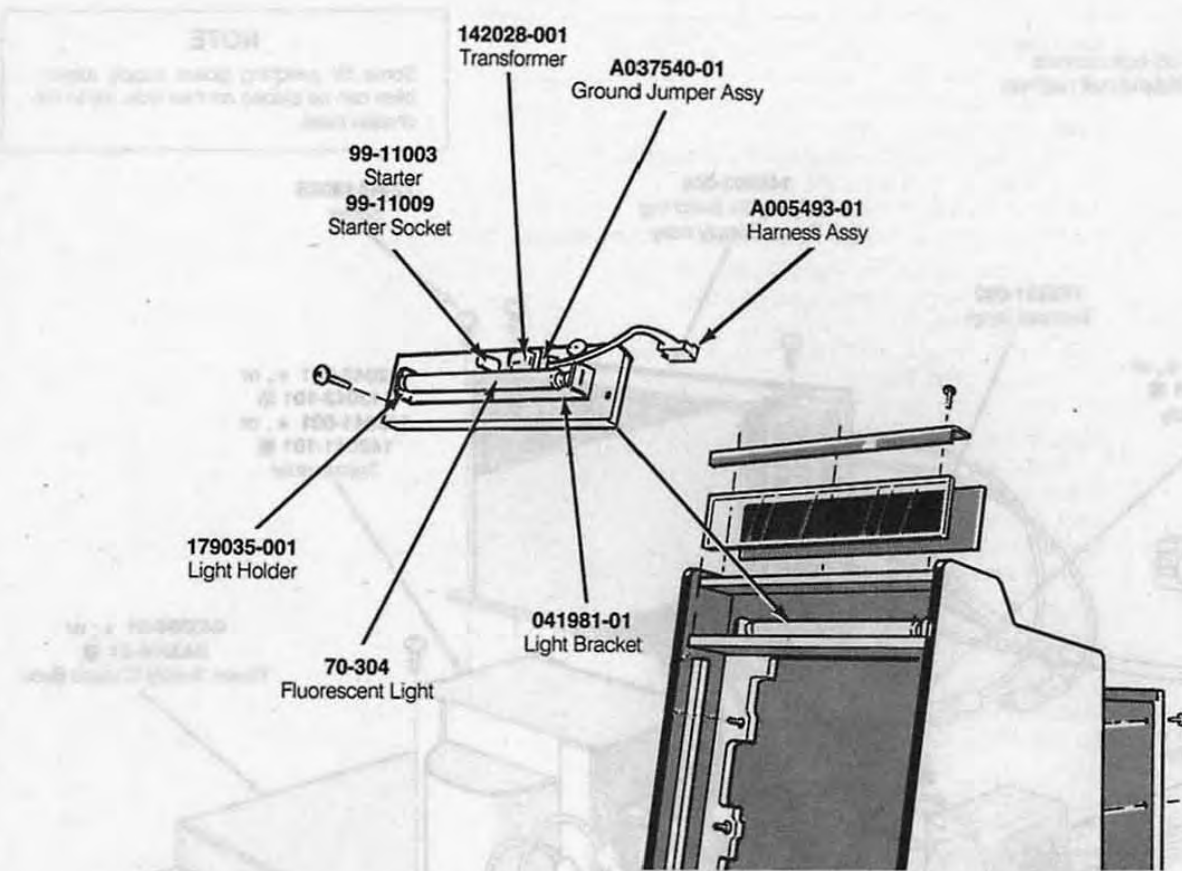

Figure 5-3 RTC Steering Control Assembly, Continued
A043968-01 D

RTC Steering Control Assembly Parts List

Part No.	Description
A043937-01	Coupler PCB Assembly
A043942-01	Control Harness Assembly
72-1206F	2-56 × ⅜-Inch Cross-Recessed Pan-Head Machine Screw
72-8010	10-32 × ⅜-Inch Socket-Head Cap Screw
72-8406	4-40 × ⅜-Inch Socket-Head Cap Screw
72-CT604	6-32 × ¼-Inch Hex Washer-Head Thread-Forming Machine Screw
73-20807	⅜-Inch Diameter × ⅞-Inch Spring Roll Pin
73-21208	⅜-Inch Diameter × ½-Inch Spring Roll Pin
75-044S	#4 Split-Lock Washer
75-07010	.320 I.D., .750 O.D., .015 Thick Special Washer
75-014S	#4 Steel/Zinc Flat Washer
040235-01	60T Spur Gear with Hub
040237-01	Anchor Nut
040238-01	Anchor Pin
040239-01	Torsion-Steering Spring
040240-01	Stop Bumper
040241-01	Spacer Bearing
040252-01	Compression Spring
040303-01	Trigger
040473-01	Jumper Wire
042044-01	Button
042045-01	Bushing
042635-01	Machined Handle (Right-Hand)
042635-02	Machined Handle (Left-Hand)
042636-01	Machined Handle Cover (Right-Hand)
042636-02	Machined Handle Cover (Left-Hand)
043928-01	Base
043929-01	Steering Head
043930-01	Cover
043950-01	Conical Compression Spring
044022-01	Encoder Shaft
044023-02	Encoder Shaft Spacer (Acceptable substitute is part no. 044023-01)
044024-01	Etched Encoder Disc
044214-01	Brace
106007-001	Penetrating Adhesive
107013-001	Lubricant
160026-001	Switch, Snap, SPDT
175002-001	Large Washer with ⅜-Inch Diameter Shaft
175002-004	#10, .062 Thick, Flat Washer
175009-170	Special Nylon Flat Washer
176022-3604	6-32 × ¼-Inch Self-Locking Socket-Head Cap Screw
176022-3606	6-32 × ⅜-Inch Self-Locking Socket-Head Cap Screw
176022-3610	6-32 × ⅝-Inch Self-Locking Socket-Head Cap Screw
176035-1820	8-32 × 1 ¼-Inch Black Type F Socket-Head Cap Screw
177010-241	#10-32 Nyloc Hex Nut
178012-001	Retaining Ring for ⅜-Inch Diameter Shaft
178012-003	Retaining Ring for ⅝-Inch Diameter Shaft
178027-001	Lubricant
178065-100	4-Inch Wire and Cable Tie
178068-200	Cable Tie Mount
178097-001	.25 Shaft Panel Bearing with Lock Washer and Nut
178101-002	24 DP × 20 PA × .583 P.D. × 2.50 Spur Gear
178118-001	Oil-Impregnated Sleeve Bearing
178203-001	Cap



**Figure 5-4 Fluorescent Light Panel Assembly
A042884-01 A**

**Fluorescent Light Panel Assembly
Parts List**

Part No.	Description
A005493-01	Fluorescent Light Harness Assembly
A037540-01	Ground Jumper Assembly
70-304	18-Inch, 15 W Fluorescent Light
72-6408S	#4 x 1/2-Inch Pan-Head Self-Tapping Screw
79-561816P	Wire Nut
99-11003	Starter
99-11006	Retaining Clip (consists of two pieces)
99-11009	Starter Socket
041981-01	Light Bracket
042920-01	Light Panel
142028-001	60 Hz Ballast Transformer
176015-110	#10 x 3/8-Inch Cross-Recessed Pan-Head Screw
179035-001	Light Holder

- ★ Part used only in US-built cabinets
- ✿ Part used only in Ireland-built cabinets

NOTE
Some 5V switching power supply assemblies can be placed on their side, flat to the chassis base.

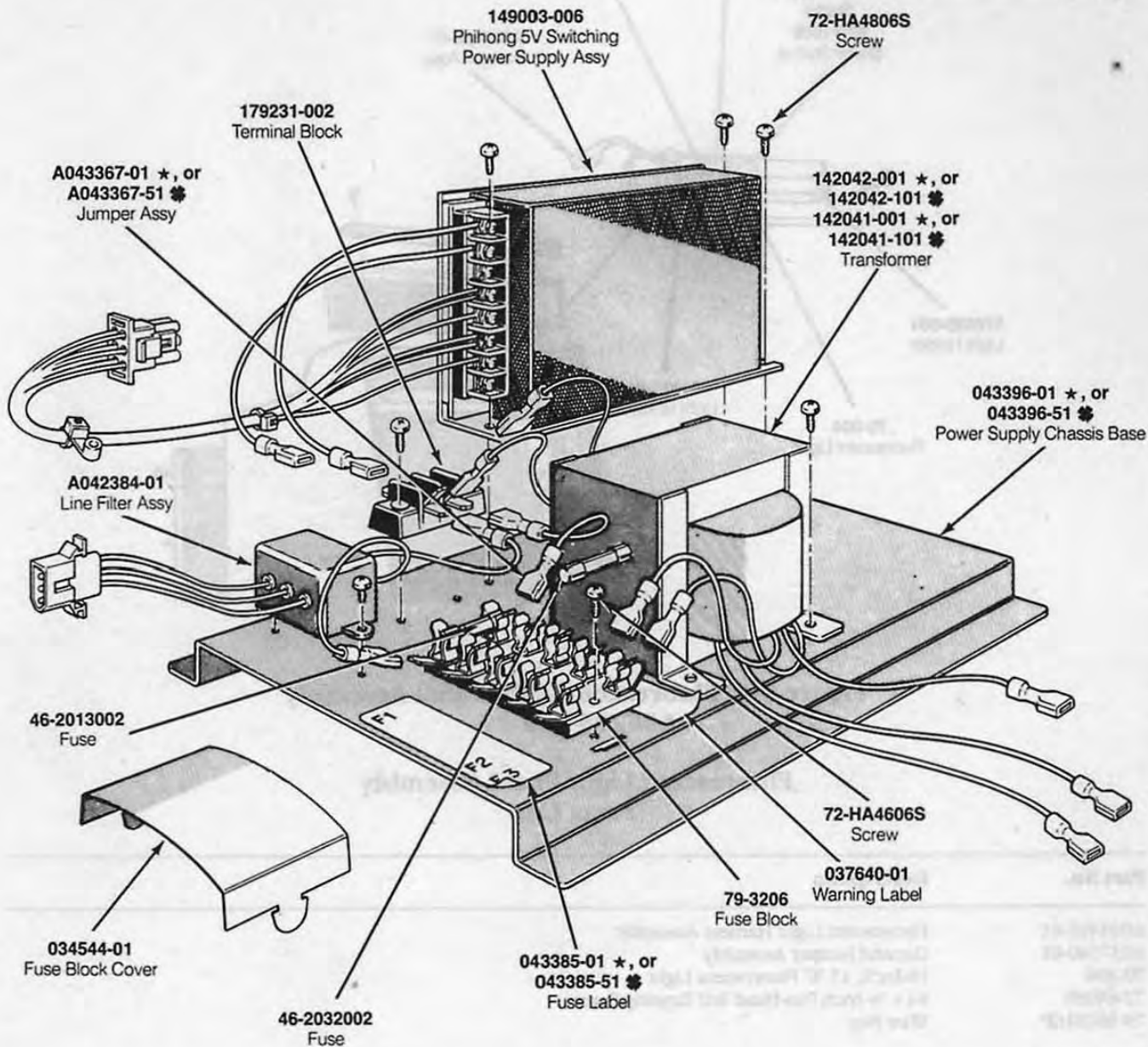

Figure 5-5 Switching/Linear (SL) Power Supply Assembly
A043363-01 E (US)
and A043363-xx E (Ireland)

Switching/Linear (SL) Power Supply Assembly Parts List

Part No.	Description
A042384-01	Line Filter Assembly
A043367-01 ★	Jumper Assembly (A043367-51 ☼)
46-2013002	250 V Slow-Blow 3 A Fuse
46-2032002	250 V Normal-Blow 2 A Fuse
72-HA4606S	#6-32 × 3/8-Inch Cross-Recessed Pan-Head Thread-Forming Screw
72-HA4806S	#8-32 × 3/8-Inch Cross-Recessed Pan-Head Thread-Forming Screw
79-3206	5-Position Fuse Block
034544-01	Fuse Block Cover
037640-01	Power Supply Warning Label
043385-01 ★	Power Supply Fuse Label (043385-51 ☼)
043396-01 ★	Power Supply Chassis Base (043396-01 ☼)
142042-001 ★	Transformer (142042-101 ☼); Acceptable substitute is part no. 142041-001 ★ (142041-101 ☼)
149003-006	Phihong 5V Switching Power Supply Assembly (see parts list below)
179231-002	2-Position Terminal Block

★ Part used only in US-built cabinets

☼ Part used only in Ireland-built cabinets

Phihong 5-Volt Power Supply Sub-Assembly Parts List

Designator	Description	Part No.
Capacitors		
C1, C2	CAPACITOR, METAL FILM, 0.1 μF, 250 V	99-212014
C3, C4	CAPACITOR, CERAMIC, .0047 μF, 400 VAC	99-212015
C6-C9	CAPACITOR, ELECTROLYTIC, 100 μF, 200 V	99-212016
C10	CAPACITOR, HIGH VOLTAGE, 470 pF, 1 kV	99-212018
C11	CAPACITOR, HIGH VOLTAGE, .01 μF, 1 kV	99-212017
C12	CAPACITOR, METAL FILM, .22 μF, 50 V	99-212019
C13	CAPACITOR, ELECTROLYTIC, 10 μF, 50 V	99-212022
C14	CAPACITOR, POLYESTER, .047 μF, 50 V	99-212020
C15	CAPACITOR, POLYESTER, .0047 μF, 50 V	99-212021
C17-C20	CAPACITOR, ELECTROLYTIC, 6800 μF, 10 V	99-212023
C21	CAPACITOR, ELECTROLYTIC, 100 μF, 200 V	99-212016
C22	CAPACITOR, POLYESTER, .047 μF, 50 V	99-212020
Diodes		
D1	DIODE, FAST, 1000 V, 1 A	99-212025
D2, D3	DIODE, FAST, 100 V, 1 A	99-212024
D4	DIODE, SCHOTTKY	99-212029
D7	DIODE, FAST, 1000 V, 1 A	99-212025
Transistors		
Q1	TRANSISTOR, 2SC3153, 800 V, 6 A	99-212030
Q2	TRANSISTOR, 2SD468C	99-212031
Resistors		
R1, R2	RESISTOR, FILM, 220 kΩ, ± 5%, 1/2 W	99-212001
R3	RESISTOR, METAL FILM, 470 Ω, ± 5%, 2 W	99-212002
R4	RESISTOR, FILM, 2.7 kΩ, ± 5%, 1/4 W	99-212013
R5	RESISTOR, METAL FILM, 82 Ω, ± 5%, 2 W	99-212004

**Phibong 5-Volt Power Supply Sub-Assembly
Parts List, Continued**

Designator	Description	Part No.
R6	RESISTOR, FILM, 4.7 kΩ, ± 5%, ¼ W	99-212006
R7	RESISTOR, FILM, 120 Ω, ± 5%, ¼ W	99-212007
R8	RESISTOR, FILM, 10 Ω, ± 5%, ¼ W	99-212008
R9	RESISTOR, METAL FILM, 1 Ω, ± 5%, 2 W	99-212005
R10	RESISTOR, FILM, 330 Ω, ± 5%, ¼ W	99-212009
R11	RESISTOR, FILM, 120 Ω, ± 5%, ¼ W	99-212007
R12	RESISTOR, FILM, 1.5 kΩ, ± 5%, ¼ W	99-212010
R13	RESISTOR, FILM, 68 Ω, ± 5%, ¼ W	99-212011
R14	RESISTOR, FILM, 33 Ω, ± 5%, ¼ W	99-212003
R15	RESISTOR, FILM, 2 kΩ, ± 5%, ¼ W	99-212012
R16	RESISTOR, FILM, 33 Ω, ± 5%, ¼ W	99-212003
R17	RESISTOR, FILM, 2 kΩ, ± 5%, ¼ W	99-212012
R18	RESISTOR, METAL FILM, 47 Ω, ± 5%, 2 W	99-212046
Miscellaneous		
F1	FUSE, 5 X 20 mm	99-212039
L1, L2	COIL	99-212032
NF	FILTER, NOISE	99-212036
PC	OPTICAL ISOLATOR, 35 V, 5 mA	99-212034
REC1	DIODE, BRIDGE, 1000 V, 1.5 A	99-212028
SCR	THYRISTOR, SCR	99-212038
SHR	SHUNT REGULATOR	99-212033
T1	TRANSFORMER	99-212043
VR	RESISTOR, VARIABLE	99-212045
ZD1	DIODE, ZENER	99-212026
ZD2	DIODE, ZENER	99-212027
	FERRITE CORE	99-212037
	FERRITE CORE	99-212044
	FUSE CLIP	99-212040
	HEAT SINK	99-212041
	HEAT SINK	99-212042
	THERMISTOR, POWER	99-212035

N O T E S

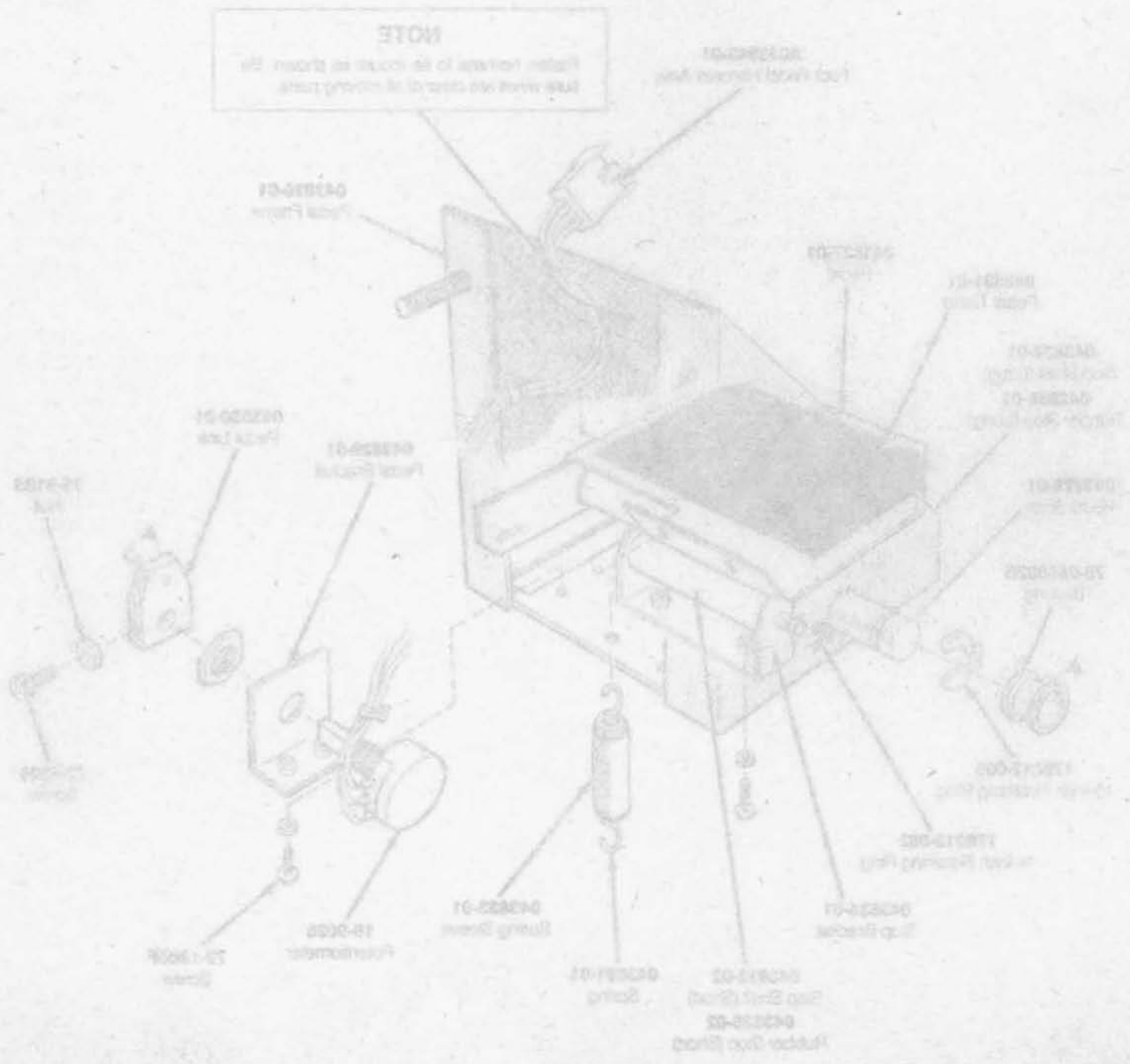

Figure 5-6 Foot Pedal Assembly
 A013825-01 A (1/2)
 and A013825-21 A (1/2)

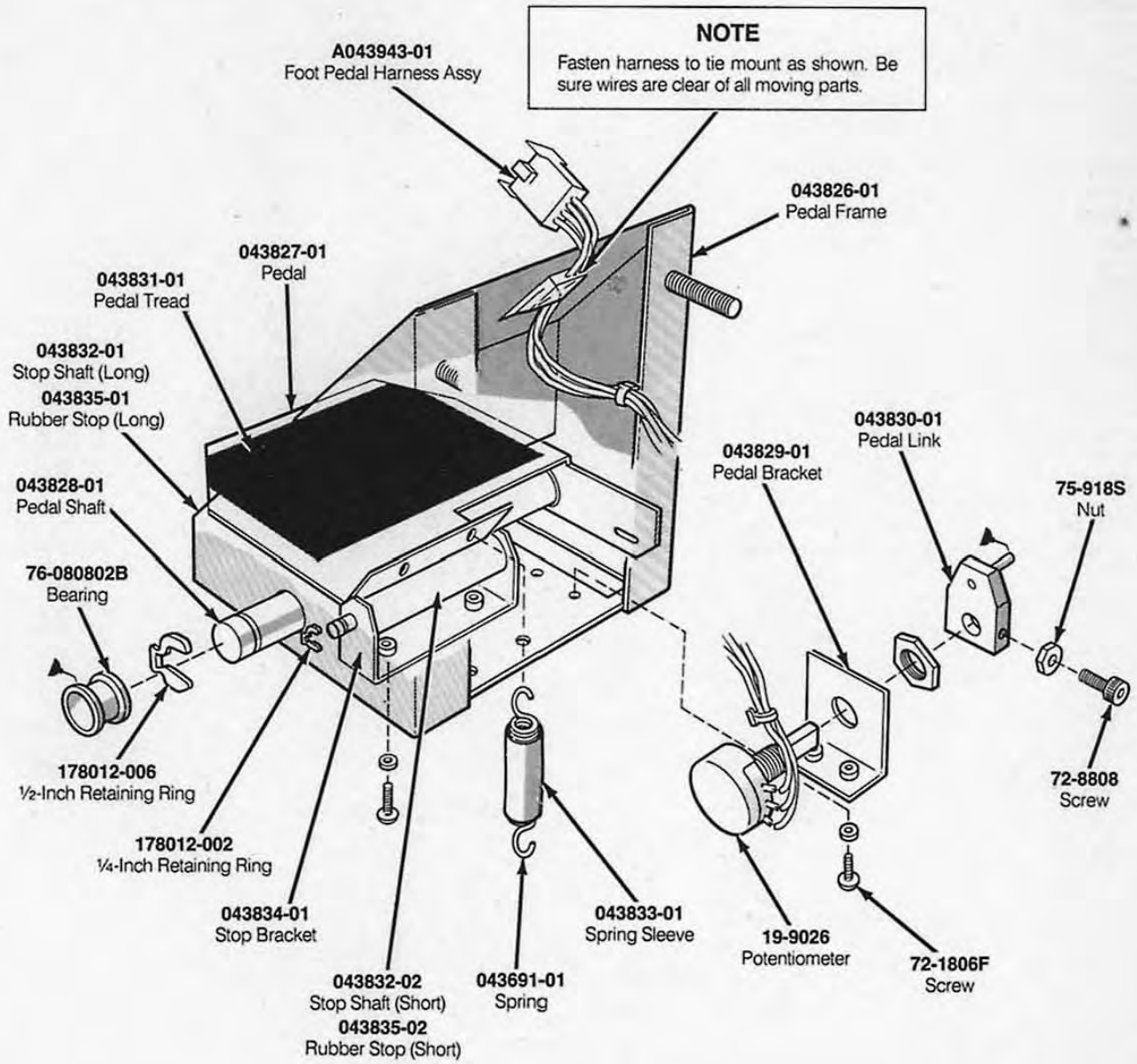
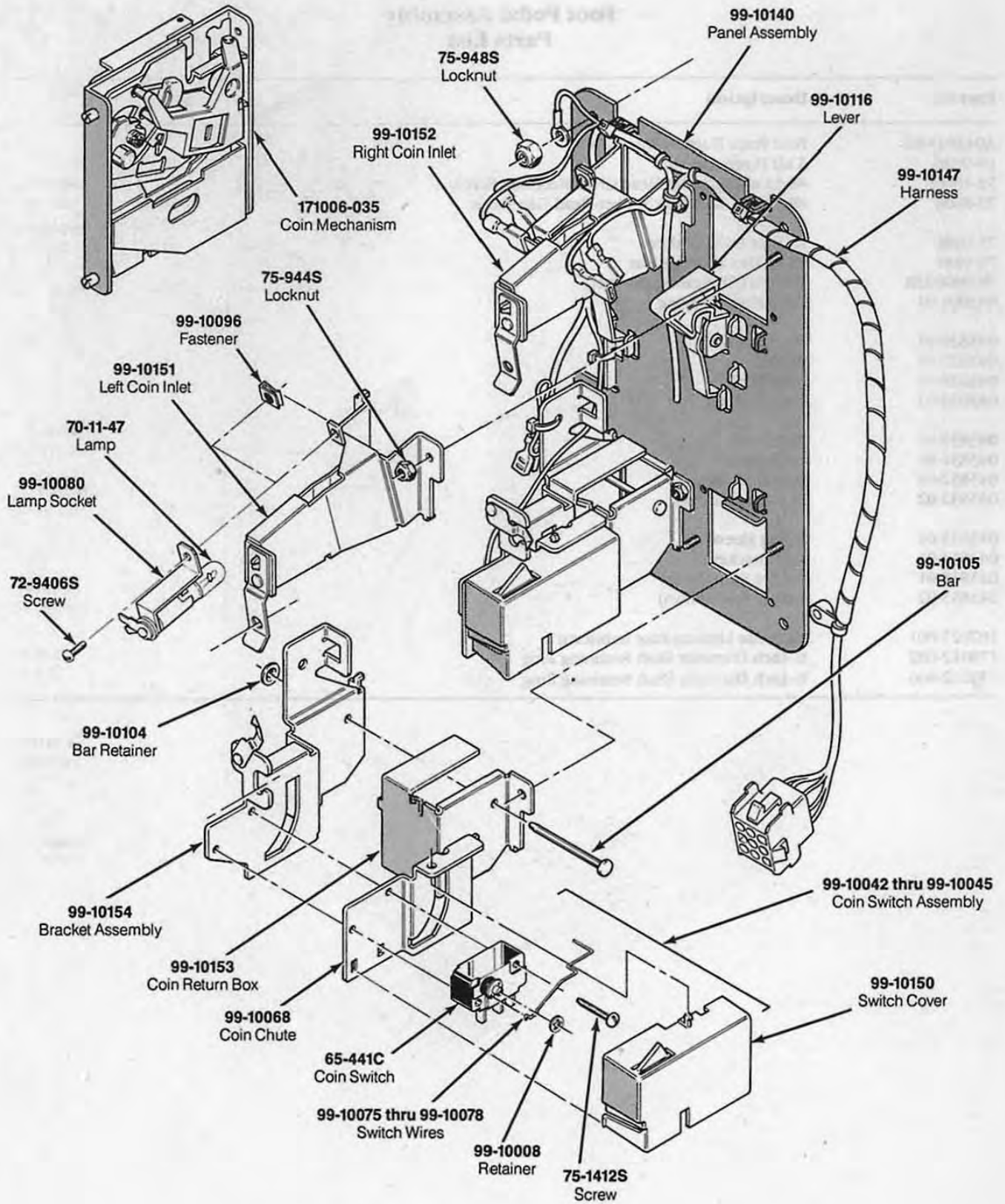

Figure 5-6 Foot Pedal Assembly
A043825-01 A (US)
and A043825-51 A (Ireland)

Foot Pedal Assembly Parts List

Part No.	Description
A043943-01	Foot Pedal Harness Assembly
19-9026	5 k Ω Potentiometer
72-1806F	#8-32 \times $\frac{1}{8}$ -Inch Pan-Head Cross-Recessed Screw
72-8808	#8-32 \times $\frac{1}{2}$ -Inch Hex Socket-Head Cap Screw
75-048C	#8 Split Lock Washer
75-918S	#8-32 Hex Machine Nut
76-080802B	$\frac{1}{2}$ -Inch I.D. Bearing (Nyliner)
043691-01	Pedal Return Spring
043826-01	Pedal Frame
043827-01	Pedal
043828-01	Pedal Shaft
043829-01	Pedal Bracket
043830-01	Pedal Link
043831-01	Pedal Tread
043832-01	Stop Shaft (Long)
043832-02	Stop Shaft (Short)
043833-01	Spring Sleeve
043834-01	Stop Bracket
043835-01	Rubber Stop (Long)
043835-02	Rubber Stop (Short)
107027-001	Multi-Use Lithium-Base Lubricant
178012-002	$\frac{1}{4}$ -Inch Diameter Shaft Retaining Ring
178012-006	$\frac{1}{2}$ -Inch Diameter Shaft Retaining Ring



**Figure 5-7 Coin Acceptors, Inc. Coin Door Assembly
171027-001 A**

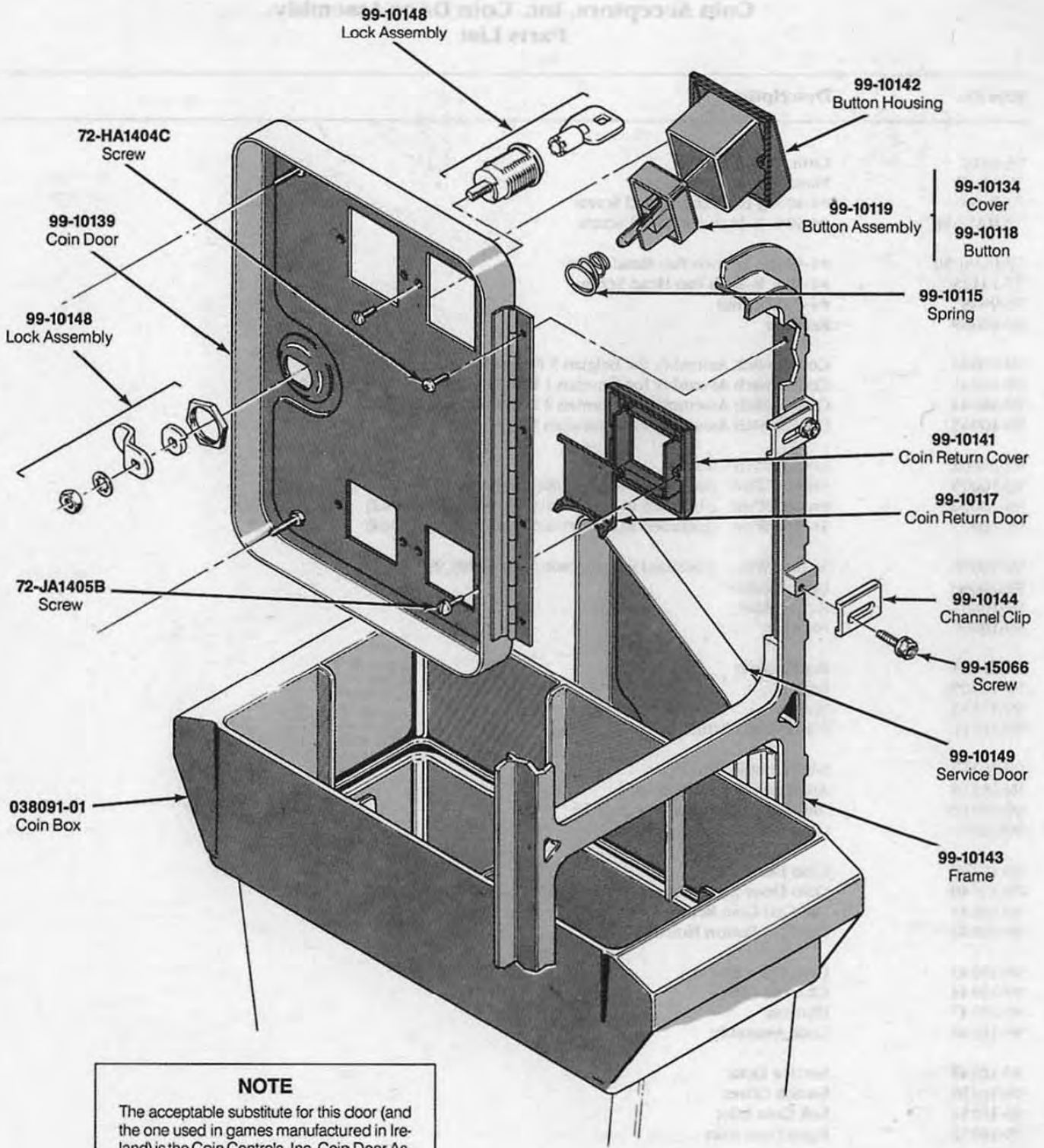
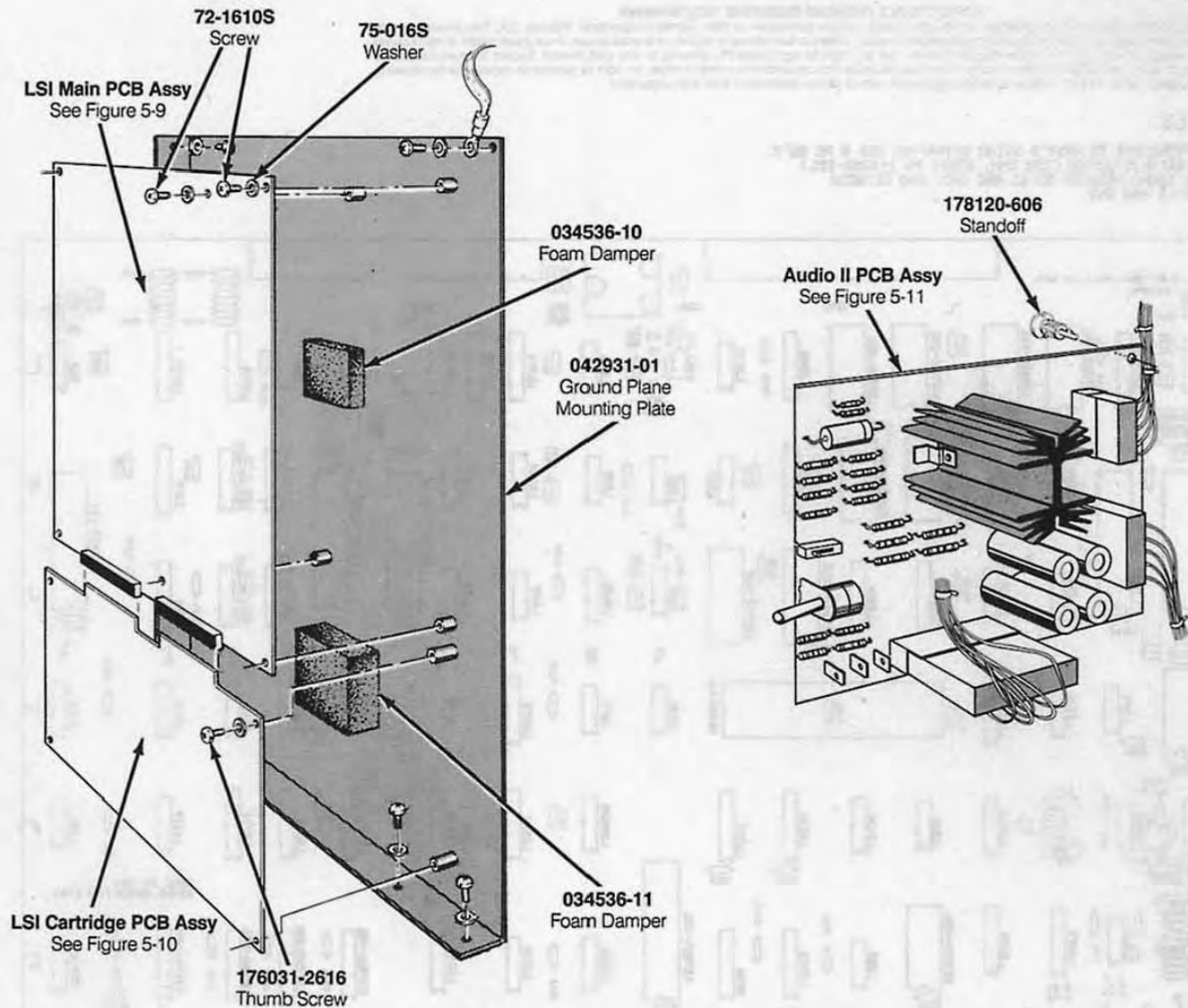

Figure 5-7 Coin Acceptors, Inc. Coin Door Assembly, Continued
171027-001 A

Coin Acceptors, Inc. Coin Door Assembly Parts List

Part No.	Description
65-441C	Coin Switch
70-11-47	Miniature Bayonet Lamp
72-9406S	#4-40 × 3/8-Inch Truss-Head Screw
72-HA1404C	#4-40 × 1/4-Inch Pan-Head Screw
72-JA1405B	#4-40 × 0.31-Inch Pan-Head Screw
75-1412S	#4-40 × 3/4-Inch Pan-Head Screw
75-994S	#4-40 Locknut
99-10008	Retainer
99-10042	Coin Switch Assembly for Belgian 5 Fr and U.S. \$.25
99-10043	Coin Switch Assembly for German 1 DM, Japanese 100 Yen, Swiss 1 Fr
99-10044	Coin Switch Assembly for German 2 DM, Italian 100 L, U.S. \$1.00
99-10045	Coin Switch Assembly for Australian \$.20, German 5 DM, British 10 P
99-10068	Coin Return Chute
99-10075	Switch Wire (included in coin switch assembly 99-10043)
99-10076	Switch Wire (included in coin switch assembly 99-10042)
99-10077	Switch Wire (included in coin switch assembly 99-10044)
99-10078	Switch Wire (included in coin switch assembly 99-10045)
99-10080	Lamp Socket
99-10081	Key Holder
99-10096	Fastener
99-10104	Bar Retainer
99-10105	Bar
99-10115	Spring
99-10116	Plastic Coin Return Lever
99-10117	Steel Coin Return Door
99-10118	Amber Coin Return Button
99-10119	Amber Coin Button for U.S. \$.25
99-10134	Coin Button Cover
99-10139	Coin Door
99-10140	Coin Door Inner-Panel Assembly
99-10141	Die-Cast Coin Return Cover
99-10142	Die-Cast Button Housing
99-10143	Coin Door Frame
99-10144	Channel Clip
99-10147	Harness
99-10148	Lock Assembly
99-10149	Service Door
99-10150	Switch Cover
99-10151	Left Coin Inlet
99-10152	Right Coin Inlet
99-10153	Coin Return Box
99-10154	Bracket Assembly
99-15066	Screw for Clamp
171006-035	Metal Coin Mechanism for U.S. \$.25



**Figure 5-8 PCB Mounting Hardware
A042932-01 F**

**PCB Mounting Hardware
Parts List**

Part No.	Description
72-1610S	#6-32 × ¾-Inch Cross-Recessed Pan-Head Machine Screw
75-016S	#6 Flat Washer
034536-10	3 × 6 × .62-Inch Foam Vibration Damper
034536-11	3 × 6 × .81-Inch Foam Vibration Damper
042931-01	PCB Ground Plane Mounting Plate
176015-112	#10 × ¾-Inch Cross-Recessed Pan-Head Deep-Threaded Screw
176031-2616	#6-32 × ½-Inch Brass Knurled Thumb Screw
178120-606	.375-Inch High PCB Standoff (Style 6)

LSI Main PCB Assembly Parts List

Designator	Description	Part No.	Designator	Description	Part No.
Integrated Circuits					
1/2A	Type-74LS74 Integrated Circuit	37-74LS74	5F	Type-74LS273 Integrated Circuit	37-74LS273
1/2B	Type-74LS194 Integrated Circuit	37-74LS194	5H	Type-74LS32 Integrated Circuit	37-74LS32
1B	Type-74LS194 Integrated Circuit	37-74LS194	5J/K	Custom Integrated Circuit	137419-102
1C	Custom Integrated Circuit	137419-101	5K/L	Type-74LS00 Integrated Circuit	37-74LS00
1F	Type-74LS86 Integrated Circuit	37-74LS86	5L	Type-74S08 Integrated Circuit	37-74S08
1H	Type-74S283 Integrated Circuit	137204-001	6A	Type-74LS273 Integrated Circuit	37-74LS273
1J/K	Custom Integrated Circuit	137419-104	6B	Type-74LS273 Integrated Circuit	37-74LS273
1L	Type-74S02 Integrated Circuit	37-74S02	6C	Type-74LS191 Integrated Circuit	37-74LS191
2/3B	Type-2364A, 300 ns PROM Integrated Circuit (Acceptable substitute is part no. 136032-107)	136032-104	6D	Type-74LS153 Integrated Circuit	37-74LS153
2C	Type-74LS174 Integrated Circuit	37-74LS174	6E	Type-74LS153 Integrated Circuit	37-74LS153
2D	Type-1MS1420, 55 ns Static RAM Integrated Circuit	137360-001	6F	Type-74LS244 Integrated Circuit	37-74LS244
2E	Type-1MS1420, 55 ns Static RAM Integrated Circuit	137360-001	6H	Type-74LS244 Integrated Circuit	37-74LS244
2F	Type-74LS174 Integrated Circuit	37-74LS174	6J	Type-74LS257 Integrated Circuit	37-74LS257
2H	Type-74S283 Integrated Circuit	137204-001	6K	Type-74LS257 Integrated Circuit	37-74LS257
2J	Type-74S374 Integrated Circuit	137206-001	6J/K	Custom Integrated Circuit	137419-102
2K	Type-74S374 Integrated Circuit	137206-001	6/L	Type-74LS244 Integrated Circuit	37-74LS244
2L	Type-74LS244 Integrated Circuit	37-74LS244	6L	Type-74LS257 Integrated Circuit	37-74LS257
3/4A	1024 x 4, 55 ns MOS Static RAM Integrated Circuit	137199-001	7A	Type-7407 Integrated Circuit	37-7407
3/4B	1024 x 4, 55 ns MOS Static RAM Integrated Circuit	137199-001	7B	Type-7407 Integrated Circuit	37-7407
3C	Type-74LS273 Integrated Circuit	37-74LS273	7C	Type-74LS191 Integrated Circuit	37-74LS191
3D	Type-1MS1420, 55 ns Static RAM Integrated Circuit	137360-001	7D	Type-74LS153 Integrated Circuit	37-74LS153
3E	Type-1MS1420, 55 ns Static RAM Integrated Circuit	137360-001	7E	Type-74LS153 Integrated Circuit	37-74LS153
3F	Type-74LS273 Integrated Circuit	37-74LS273	7F	Type-74LS373 Integrated Circuit	37-74LS373
3H	Type-74S283 Integrated Circuit	137204-001	7H	Type-74LS373 Integrated Circuit	37-74LS373
3J	1024 x 4, 45 ns MOS Static RAM Integrated Circuit	137199-002	7J	Type-74LS32 Integrated Circuit	37-74LS32
3K	1024 x 4, 45 ns MOS Static RAM Integrated Circuit	137199-002	7K	Type-74LS139 Integrated Circuit	37-74LS139
3L	Type-74LS244 Integrated Circuit	37-74LS244	7L	Type-74LS374 Integrated Circuit	37-74LS374
4C	Type-74LS151 Integrated Circuit	37-74LS151	8A	Type-74S260 Integrated Circuit	37-74S260
4D	Type-1MS1420, 55 ns Static RAM Integrated Circuit	137360-001	8B	Type-7407 Integrated Circuit	37-7407
4E	Type-1MS1420, 55 ns Static RAM Integrated Circuit	137360-001	8C	Type-74LS191 Integrated Circuit	37-74LS191
4F	Type-74LS273 Integrated Circuit	37-74LS273	8D	Type-74LS153 Integrated Circuit	37-74LS153
4H	Type-74S283 Integrated Circuit	137204-001	8E	Type-74LS153 Integrated Circuit	37-74LS153
4J	1024 x 4, 45 ns MOS Static RAM Integrated Circuit	137199-002	8F	Type-74LS368A Integrated Circuit	137168-001
4K	1024 x 4, 45 ns MOS Static RAM Integrated Circuit	137199-002	8H	Type-74LS74 Integrated Circuit	37-74LS74
4L	Type-74S20 Integrated Circuit	137423-001	8J	Type-74LS138 Integrated Circuit	137177-001
5/6A	Type-74LS245 Integrated Circuit	37-74LS245	8K	Type-74LS32 Integrated Circuit	37-74LS32
5/6B	Type-74LS245 Integrated Circuit	37-74LS245	8L	Type-74LS74 Integrated Circuit	37-74LS74
5A	1024 x 4, 55ns MOS Static RAM Integrated Circuit	137199-001	9C	Type-74LS273 Integrated Circuit	37-74LS273
5B	1024 x 4, 55ns MOS Static RAM Integrated Circuit	137199-001	9D	Type-74LS74 Integrated Circuit	37-74LS74
5C	Type-74LS244 Integrated Circuit	37-74LS244	9E	Custom Integrated Circuit	137419-103
5D	Type-1MS1420, 55 ns Static RAM Integrated Circuit	137360-001	9H	Type-74LS32 Integrated Circuit	37-74LS32
5E	Type-1MS1420, 55 ns Static RAM Integrated Circuit	137360-001	9J	Type-7407 Integrated Circuit	37-7407
			9K	Type-74LS08 Integrated Circuit	37-74LS08
			10C	Type-74LS02 Integrated Circuit	37-74LS02
			10D	Type-74S74 Integrated Circuit	37-74S74
			10E	Type-74S240 Integrated Circuit	137416-001
			10F	Type-74LS245 Integrated Circuit	37-74LS245
			10J	Type-23128A, 200 ns PROM Integrated Circuit (Acceptable substitute is part no. 136032-115)	136032-113
			10K	Type-74LS14 Integrated Circuit	37-74LS14
			10L	Type-74LS197 Integrated Circuit	137240-001
			11C	Type-74LS163A Integrated Circuit	37-74LS163A
			11E	Type-74LS245 Integrated Circuit	37-74LS245
			11F	Type-74LS245 Integrated Circuit	37-74LS245
			11J	Type-23128A, 200 ns PROM Integrated Circuit (Acceptable substitute is part no. 136032-114)	136032-112
			11K	Type-74LS245 Integrated Circuit	37-74LS245

LSI Main PCB Assembly Parts List, Continued

Designator	Description	Part No.	Designator	Description	Part No.
11L	Type-74LS245 Integrated Circuit	37-74LS245	C62	100 pF, 100 V Mica Capacitor	128002-101
12C	LETA Integrated Circuit	137304-1001	C63	.1 μ F, 50 V Ceramic Capacitor	122002-104
12E	Type-74LS20 Integrated Circuit	37-74LS20	C64	1000 pF, 100 V Ceramic Capacitor	122016-102
12F	Type-74LS138 Integrated Circuit	137177-001	C65	1000 pF, 100 V Ceramic Capacitor	122016-102
12H	Type-68010-L8 Microprocessor	137414-001	C66	.1 μ F, 50 V Ceramic Capacitor	122002-104
12J	Type-74LS244 Integrated Circuit	37-74LS244	C67	.1 μ F, 50 V Ceramic Capacitor	122002-104
12K	2048 \times 8, 150 ns Static RAM Integrated Circuit	137211-001	C68	1000 pF, 100 V Ceramic Capacitor	122016-102
12L	2048 \times 8, 150 ns Static RAM Integrated Circuit	137211-001	C69	1000 pF, 100 V Ceramic Capacitor	122016-102
13C	Type-ADC0809 Integrated Circuit	137243-001	C70	.1 μ F, 50 V Ceramic Capacitor	122002-104
13D	Type-74LS368A Integrated Circuit	137168-001	C71	.1 μ F, 50 V Ceramic Capacitor	122002-104
13E	Type-2804, 450 ns EEROM Integrated Circuit	137329-450	C72	.001 μ F, 50 V Ceramic Capacitor	122002-102
13F	Type-74LS32 Integrated Circuit	37-74LS32	C73	10 μ F, 25 V Electrolytic Capacitor	24-250106
13J	Type-74LS244 Integrated Circuit	37-74LS244	C74	1000 pF, 100 V Ceramic Capacitor	122016-102
13K	2048 \times 8, 150 ns Static RAM Integrated Circuit	137211-001	C75	1 μ F, 50 V Electrolytic Capacitor	24-500105
13L	2048 \times 8, 150 ns Static RAM Integrated Circuit	137211-001	C76	1 μ F, 50 V Electrolytic Capacitor	24-500105
14C	Type-74LS244 Integrated Circuit	37-74LS244	C77	.0027, 50 V Ceramic Capacitor	122015-272
14D	Type-74LS138 Integrated Circuit	137177-001	C78	.0027, 50 V Ceramic Capacitor	122015-272
14E	Type-74LS374 Integrated Circuit	37-74LS374	C79	1 μ F, 50 V Electrolytic Capacitor	24-500105
14F	Type-74LS259 Integrated Circuit	37-74LS259	C80	.1 μ F, 50 V Ceramic Capacitor	122002-104
14H	Type-74LS245 Integrated Circuit	37-74LS245	C81	.1 μ F, 50 V Ceramic Capacitor	122002-104
14J	Type-74LS139 Integrated Circuit	37-74LS139	C82-C84	10 μ F, 25 V Electrolytic Capacitor	24-250106
14K	Type-74LS244 Integrated Circuit	37-74LS244	C85-C154	.1 μ F, 50 V Ceramic Capacitor	122002-104
14L	2048 \times 8, 150 ns Static RAM Integrated Circuit	137211-001	C155	10 μ F, 25 V Electrolytic Capacitor	24-250106
15C	Type-74LS367A Integrated Circuit	37-74LS367	C156	10 μ F, 25 V Electrolytic Capacitor	24-250106
15E	Type-74LS374 Integrated Circuit	37-74LS374	C158-C160	.1 μ F, 50 V Ceramic Capacitor	122002-104
15H	Type-74LS138 Integrated Circuit	137177-001	Diodes		
15J	Type-74LS00 Integrated Circuit	37-74LS00	CR1, CR2	Type-IN4148 Diode	131033-001
15K	Type-74LS244 Integrated Circuit	37-74LS244	CR3	Type-MV5053 Diode	38-MV5053
15L	2048 \times 8, 150 ns Static RAM Integrated Circuit	137211-001	CR4	Type-IN754A Diode	131002-001
16D	Type-LM324 Integrated Circuit	37-LM324	CR5	Type-MV5053 Diode	38-MV5053
16E	Type-LM324 Integrated Circuit	37-LM324	Connectors		
16F	Type-LM324 Integrated Circuit	37-LM324	CP1, CP2	80-Position Card Edge Connector	179221-180
16J/K	Type-6502A Microprocessor	90-6013	J101	12-Position Header Connector	179069-012
16H	Type-74LS74 Integrated Circuit	37-74LS74	J102-J104	11-Position Square Pin Header Connector	179118-011
16L	Type-74LS245 Integrated Circuit	37-74LS245	J105	6-Position Square Pin Header Connector	179118-006
17F	Type-YM3012 Integrated Circuit	137402-001	J106	11-Position Square Pin Header Connector	179118-011
17H	Type-YM2151 Integrated Circuit	137401-001	J107	5-Position Square Pin Header Connector	179118-005
17J/K	Custom Integrated Circuit	C012294	J108	8-Position Square Pin Header Connector	179118-008
17L	Type-74LS148 Integrated Circuit	137417-001	Inductors		
Capacitors			L1	68 μ H Inductor	141016-008
C1	100 μ F, 25 V Electrolytic Capacitor	24-250107	L2-L4	1 μ H Inductor	141007-001
C2	.1 μ F, 50 V Ceramic Capacitor	122002-104	L5	100 μ H Inductor	41-3003
C3-C5	470 pF, 50 V Ceramic Capacitor	122013-471	Transistors		
C6-C8	1000 pF, 100 V Ceramic Capacitor	122016-102	Q1	Type-2N3906 Transistor	33-2N3906
C9	.1 μ F, 50 V Ceramic Capacitor	122002-104	Q2	Type-2N3643 Transistor	34-2N3643
C10-C17	.01 μ F, 25 V Ceramic Capacitor	122005-103	Q3-Q5	Type-2N3904 Transistor	34-2N3904
C18-C40	.1 μ F, 50 V Ceramic Capacitor	122002-104	Q6-Q8	Type-2N3906 Transistor	33-2N3906
C41	10 μ F, 25 V Electrolytic Capacitor	24-250106	Q9, Q10	Type-2N6044 Transistor	34-2N6044
C42-C58	.1 μ F, 50 V Ceramic Capacitor	122002-104	Q11-Q13	Type-2N3904 Transistor	34-2N3904
C59	.01 μ F, 25 V Ceramic Capacitor	122005-103	Resistors		
C60	.01 μ F, 25 V Ceramic Capacitor	122005-103	R1	510 Ω , \pm 5%, $\frac{1}{4}$ W Resistor	110000-511
C61	39 pF, 100 V Mica Capacitor	128002-390	R2	68 Ω , \pm 5%, $\frac{1}{4}$ W Resistor	110000-680
			R3-R6	27 Ω , \pm 5%, $\frac{1}{4}$ W Resistor	110000-270
			R7	20 k Ω , \pm 5%, $\frac{1}{4}$ W Resistor	110000-203
			R8	10 k Ω , \pm 5%, $\frac{1}{4}$ W Resistor	110000-103
			R9	4.99 k Ω , \pm 1%, $\frac{1}{4}$ W Resistor	110011-502

LSI Main PCB Assembly Parts List, Continued

Designator	Description	Part No.	Designator	Description	Part No.
R10	2.49 k Ω , \pm 1%, 1/4 W Resistor	110011-252	R118	22 k Ω , \pm 5%, 1/4 W Resistor	110000-223
R11-R14	100 Ω , \pm 5%, 1/4 W Resistor	110000-101	R119	1 k Ω , \pm 5%, 1/4 W Resistor	110000-102
R15	2.2 k Ω , \pm 5%, 1/4 W Resistor	110000-222	R120, R121	10 k Ω , \pm 5%, 1/4 W Resistor	110000-103
R16-R19	330 Ω , \pm 5%, 1/4 W Resistor	110000-331	R122	1 k Ω , \pm 5%, 1/4 W Resistor	110000-102
R20	2.2 k Ω , \pm 5%, 1/4 W Resistor	110000-222	R123	22 k Ω , \pm 5%, 1/4 W Resistor	110000-223
R21	4.7 k Ω , \pm 5%, 1/4 W Resistor	110000-472	R124	15 k Ω , \pm 5%, 1/4 W Resistor	110000-153
R22	10 k Ω , \pm 5%, 1/4 W Resistor	110000-103	R125	10 k Ω , \pm 5%, 1/4 W Resistor	110000-103
R23	20 k Ω , \pm 5%, 1/4 W Resistor	110000-203	R126	39 k Ω , \pm 5%, 1/4 W Resistor	110000-393
R24-R27	330 Ω , \pm 5%, 1/4 W Resistor	110000-331	R127, R128	27 k Ω , \pm 5%, 1/4 W Resistor	110000-273
R28	2.2 k Ω , \pm 5%, 1/4 W Resistor	110000-222	R129	39 k Ω , \pm 5%, 1/4 W Resistor	110000-393
R29	4.7 k Ω , \pm 5%, 1/4 W Resistor	110000-472	R130	10 k Ω , \pm 5%, 1/4 W Resistor	110000-103
R30	10 k Ω , \pm 5%, 1/4 W Resistor	110000-103	R131	15 k Ω , \pm 5%, 1/4 W Resistor	110000-153
R31	20 k Ω , \pm 5%, 1/4 W Resistor	110000-203	R132, R133	10 k Ω , \pm 5%, 1/4 W Resistor	110000-103
R32-R35	330 Ω , \pm 5%, 1/4 W Resistor	110000-331	R134	1 k Ω , \pm 5%, 1/4 W Resistor	110000-102
R36	2.2 k Ω , \pm 5%, 1/4 W Resistor	110000-222	R135	390 Ω , \pm 5%, 1/4 W Resistor	110000-391
R37	4.7 k Ω , \pm 5%, 1/4 W Resistor	110000-472	R136	560 Ω , \pm 5%, 1/4 W Resistor	110000-561
R38	10 k Ω , \pm 5%, 1/4 W Resistor	110000-103	R137, R138	1 k Ω , \pm 5%, 1/4 W Resistor	110000-102
R39	20 k Ω , \pm 5%, 1/4 W Resistor	110000-203	R139, R140	10 k Ω , \pm 5%, 1/4 W Resistor	110000-103
R40-R45	68 Ω , \pm 5%, 1/4 W Resistor	110000-680	R141	4.7 k Ω , \pm 5%, 1/4 W Resistor	110000-472
R46-R48	510 Ω , \pm 5%, 1/4 W Resistor	110000-511	R142	1 k Ω , \pm 5%, 1/4 W Resistor	110000-102
R49-R62	10 k Ω , \pm 5%, 1/4 W Resistor	110000-103	R143, R144	4.7 k Ω , \pm 5%, 1/4 W Resistor	110000-472
R63-R70	3.3 k Ω , \pm 5%, 1/4 W Resistor	110000-332	R145	10 k Ω , \pm 5%, 1/4 W Resistor	110000-103
R71, R72	10 k Ω , \pm 5%, 1/4 W Resistor	110000-103	R146	1 k Ω , \pm 5%, 1/4 W Resistor	110000-102
R73-R80	100 Ω , \pm 5%, 1/4 W Resistor	110000-101	R147	4.7 k Ω , \pm 5%, 1/4 W Resistor	110000-472
R81-R85	1 k Ω , \pm 5%, 1/4 W Resistor	110000-102	R148	1 k Ω , \pm 5%, 1/4 W Resistor	110000-102
R86-R90	470 Ω , \pm 5%, 1/4 W Resistor	110000-471	R149	220 Ω , \pm 5%, 1/2 W Resistor	110001-221
R91-R94	1 k Ω , \pm 5%, 1/4 W Resistor	110000-102	R150, R151	4.7 k Ω , \pm 5%, 1/4 W Resistor	110000-472
R95	150 Ω , \pm 5%, 1/4 W Resistor	110000-151	R152-R167	1 k Ω , \pm 5%, 1/4 W Resistor	110000-102
R96	220 Ω , \pm 5%, 1/4 W Resistor	110000-221	R168	220 Ω , \pm 5%, 1/4 W Resistor	110000-221
R97	150 Ω , \pm 5%, 1/4 W Resistor	110000-151	R169, R170	4.7 k Ω , \pm 5%, 1/4 W Resistor	110000-472
R98	4.7 k Ω , \pm 5%, 1/4 W Resistor	110000-472	R171, R172	47 Ω , \pm 5%, 1/4 W Resistor	110000-470
R99	1 k Ω , \pm 5%, 1/4 W Resistor	110000-102	R173	220 Ω , \pm 5%, 1/4 W Resistor	110000-221
R100	220 Ω , \pm 5%, 1/4 W Resistor	110000-221	R174, R175	330 Ω , \pm 5%, 1/4 W Resistor	110000-331
R101	4.7 k Ω , \pm 5%, 1/4 W Resistor	110000-472	R176	1 k Ω , \pm 5%, 1/4 W Resistor	110000-102
R102	1 k Ω , \pm 5%, 1/4 W Resistor	110000-102	R177, R178	330 Ω , \pm 5%, 1/4 W Resistor	110000-331
R103	470 Ω , \pm 5%, 1/4 W Resistor	110000-471			
R104	1 k Ω , \pm 5%, 1/4 W Resistor	110000-102			
R105	470 Ω , \pm 5%, 1/4 W Resistor	110000-471			
R106	1 k Ω , \pm 5%, 1/4 W Resistor	110000-102			
R107	470 Ω , \pm 5%, 1/4 W Resistor	110000-471			
R108	1 k Ω , \pm 5%, 1/4 W Resistor	110000-102			
R109	470 Ω , \pm 5%, 1/4 W Resistor	110000-471			
R110, R111	220 Ω , \pm 5%, 1/4 W Resistor	110000-221			
R112	1 k Ω , \pm 5%, 1/4 W Resistor	110000-102			
R113	390 Ω , \pm 5%, 1/4 W Resistor	110000-391			
R114, R115	10 k Ω , \pm 5%, 1/4 W Resistor	110000-103			
R116	4.7 k Ω , \pm 5%, 1/4 W Resistor	110000-472			
R117	15 k Ω , \pm 5%, 1/4 W Resistor	110000-153			
				Sockets	
				16-Pin, Medium-Insertion-Force, IC Socket	79-42C16
				24-Pin, Medium-Insertion-Force, IC Socket	79-42C24
				28-Pin, Medium-Insertion-Force, IC Socket	79-42C28
				40-Pin, Medium-Insertion-Force, IC Socket	79-42C40
				64-Pin, Medium-Insertion-Force, IC Socket	79-42C64
				Miscellaneous	
			Q9, Q10	Nylon Snap-In Fastener	81-4302
			Y1	14.381 MHz Crystal	90-101
				Test Point (Acceptable substitute is part no. 020670-01)	179051-002

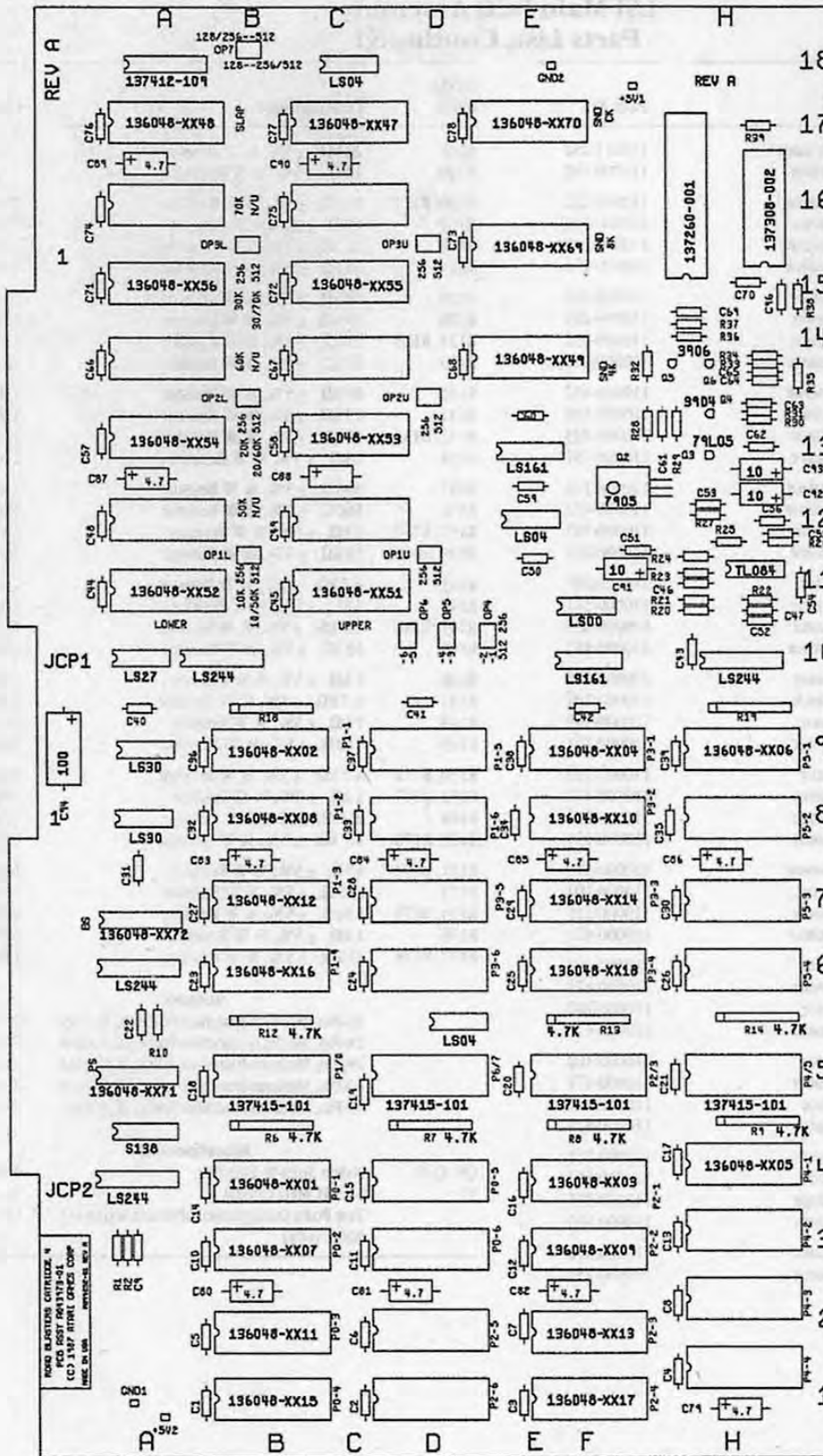

NOTICE TO ALL PERSONS RECEIVING THIS DRAWING
 CONFIDENTIAL: Reproduction forbidden without the specific written permission of Alan Games Corporation, Milpitas, CA. This drawing is only conditionally issued, and neither receipt nor possession thereof confers or transfers any right in, or license to use, the subject matter of the drawing or any design or technical information shown thereon, nor any right to reproduce this drawing or any part thereof. Except for manufacture by vendors of Alan Games Corporation, and for manufacture under the corporation's written license, no right is granted to reproduce this drawing or the subject matter thereof, unless by written agreement with or written permission from the corporation.

NOTE: This illustration shows almost all parts required for both the Cartridge 3 and Cartridge 4 PCB assemblies. Refer to the two parts lists on the following pages for the actual parts used.

Figure 5-10 LSI Cartridge 3 and 4 PCB Assemblies

LSI Cartridge 3 PCB Assembly Parts List A043972-01 C

Designator	Description	Part No.	Designator	Description	Part No.
Integrated Circuits					
1B	IC, EPROM, 27256, 300 ns	136048-1127	15/16E	IC, EPROM, 27128, 300 ns	136048-1169
1D	IC, EPROM, 27512, 300 ns	136048-1117	16A	IC, EPROM, 27256, 200 ns	136048-1168
1F	IC, EPROM, 27256, 300 ns	136048-1129	16C	IC, EPROM, 27256, 200 ns	136048-1167
2B	IC, EPROM, 27256, 300 ns	136048-1123	16F/H	IC, Interface Adapter, 6522A	137260-001
2D	IC, EPROM, 27256, 300 ns	136048-1133	16H	IC, LPC, Voice Synthesis Processor, 5220C	137308-002
2F	IC, EPROM, 27256, 300 ns	136048-1125	17A	IC, EPROM, 27128, 200 ns	136048-1148
3B	IC, EPROM, 27256, 300 ns	136048-1119	17C	IC, EPROM, 27128, 200 ns	136048-1147
3D	IC, EPROM, 27512, 300 ns	136048-1115	17E	IC, EPROM, 27128, 300 ns	136048-1170
3F	IC, EPROM, 27256, 300 ns	136048-1121	18A	IC, SLAPSTIC	137412-109
4A	IC, 74LS244	37-74LS244	18C	IC, 74LS04	37-74LS04
4B	IC, EPROM, 27256, 300 ns	136048-1101	Capacitors		
4D	IC, EPROM, 27256, 300 ns	136048-1131	C1-C45	Capacitor, .1 μ F, 50 V, Ceramic	122002-104
4F	IC, EPROM, 27256, 300 ns	136048-1103	C46	Capacitor, .22 μ F, 25 V, Ceramic	122004-224
4H	IC, EPROM, 27256, 300 ns	136048-1105	C47	Capacitor, .0068 μ F, 50 V, Ceramic	122015-682
5/6D	IC, 74LS04	37-74LS04	C48-C52	Capacitor, .1 μ F, 50 V, Ceramic	122002-104
5A	IC, PROM, 74S473	136048-1173	C53	Capacitor, .22 μ F, 25 V, Ceramic	122004-224
5B, 5D, 5F, 5H	IC, SLAGS	137415-101	C54	Capacitor, .1 μ F, 50 V, Ceramic	122002-104
6/7A	IC, PROM, 74S472	136048-1175	C55	Capacitor, .22 μ F, 25 V, Ceramic	122004-224
6A	IC, 74LS244	37-74LS244	C56	Capacitor, .0039 μ F, 50 V, Ceramic	122015-392
6B	IC, EPROM, 27256, 300 ns	136048-1128	C57-C62	Capacitor, .1 μ F, 50 V, Ceramic	122002-104
6D	IC, EPROM, 27512, 300 ns	136048-1118	C63	Capacitor, .0012 μ F, 50 V, Ceramic	122015-122
6F	IC, EPROM, 27256, 300 ns	136048-1130	C64	Capacitor, .018 μ F, 50 V, Ceramic	122015-183
7B	IC, EPROM, 27256, 300 ns	136048-1124	C65	Capacitor, 100 pF, 100 V, Ceramic	122016-101
7D	IC, EPROM, 27256, 300 ns	136048-1134	C66-C78	Capacitor, .1 μ F, 50 V, Ceramic	122002-104
7F	IC, EPROM, 27256, 300 ns	136048-1126	C79-C90	Capacitor, 4.7 μ F, 50 V, Electrolytic	24-500475
8A	IC, 74LS30	37-74LS30	C91-C93	Capacitor, 10 μ F, 35 V, Electrolytic	24-350106
8B	IC, EPROM, 27256, 300 ns	136048-1120	C94	Capacitor, 100 μ F, 25 V, Electrolytic	24-250107
8D	IC, EPROM, 27512, 300 ns	136048-1116	C96	Capacitor, .0027 μ F, 50 V, Ceramic	122015-272
8F	IC, EPROM, 27256, 300 ns	136048-1122	Transistors		
9A	IC, 74LS30	37-74LS30	Q3	IC, 79L05 (Acceptable substitute is part no. 37-7905)	37-79L05
9B	IC, EPROM, 27256, 300 ns	136048-1102	Q4	Transistor, 2N3904	34-2N3904
9D	IC, EPROM, 27256, 300 ns	136048-1132	Q5, Q6	Transistor, 2N3906	33-2N3906
9F	IC, EPROM, 27556, 300 ns	136048-1104	Resistors		
9H	IC, EPROM, 27256, 300 ns	136048-1106	R1	Resistor, 330 Ω , $\pm 5\%$, $\frac{1}{4}$ W	110000-331
10/11F	IC, 74LS00	37-74LS00	R2	Resistor, 220 Ω , $\pm 5\%$, $\frac{1}{4}$ W	110000-221
10A	IC, 74LS27	37-74LS27	R3, R4	Resistor, 4.7 K Ω , $\pm 5\%$, $\frac{1}{4}$ W	110000-472
10B	IC, 74LS244	37-74LS244	R5	Resistor, 2.4 K Ω , $\pm 5\%$, $\frac{1}{4}$ W	110000-242
10F	IC, 74LS161	37-74LS161	R6-R9	Resistor, 4.7K \times 9 Ω , $\pm 5\%$, $\frac{1}{4}$ W, SIP (10-Pin)	118010-472
11A*	IC, EPROM, 27256, 200 ns	136048-1158	R10, R11	Resistor, 2.4 K Ω , $\pm 5\%$, $\frac{1}{4}$ W	110000-242
11C*	IC, EPROM, 27256, 200 ns	136048-1157	R12-R14	Resistor, 4.7K \times 9 Ω , $\pm 5\%$, $\frac{1}{4}$ W, SIP (10-Pin)	118010-472
11H	IC, Op Amp, TL084	37-347	R15-R17	Resistor, 2.4 K Ω , $\pm 5\%$, $\frac{1}{4}$ W	110000-242
12A	IC, EPROM, 27256, 200 ns	136048-1164	R20	Resistor, 10 K Ω , $\pm 5\%$, $\frac{1}{4}$ W	110000-103
12C	IC, EPROM, 27256, 200 ns	136048-1163	R21	Resistor, 5.6 K Ω , $\pm 5\%$, $\frac{1}{4}$ W	110000-562
12E	IC, 74LS04	37-74LS04	R22	Resistor, 10 K Ω , $\pm 5\%$, $\frac{1}{4}$ W	110000-103
13A*	IC, EPROM, 27256, 200 ns	136048-1160	R23	Resistor, 43 K Ω , $\pm 5\%$, $\frac{1}{4}$ W	110000-433
13C*	IC, EPROM, 27256, 200 ns	136048-1159	R24, R25	Resistor, 20 K Ω , $\pm 5\%$, $\frac{1}{4}$ W	110000-203
13E	IC, 74LS161	37-74LS161	R26	Resistor, 43 K Ω , $\pm 5\%$, $\frac{1}{4}$ W	110000-433
14A	IC, EPROM, 27256, 200 ns	136048-1166	R27	Resistor, 1.8 K Ω , $\pm 5\%$, $\frac{1}{4}$ W	110000-182
14C	IC, EPROM, 27256, 200 ns	136048-1165	R28	Resistor, 3.3 K Ω , $\pm 5\%$, $\frac{1}{4}$ W	110000-332
14E	IC, EPROM, 27128, 300 ns	136048-1149			

*The part number for the German version of this IC is identical except that the second digit of the suffix is a "2" instead of a "1" (i.e., 136048-x2xx).

LSI Cartridge 3 PCB Assembly Parts List, Continued

Designator	Description	Part No.	Designator	Description	Part No.
R29	Resistor, 390 Ω , $\pm 5\%$, $\frac{1}{4}$ W	110000-391	Miscellaneous		
R30	Resistor, 56 K Ω , $\pm 5\%$, $\frac{1}{4}$ W	110000-563	+ 5V1, + 5V2	Test Point	179051-002
R31	Resistor, 12 K Ω , $\pm 5\%$, $\frac{1}{4}$ W	110000-123	GND1, GND2	Test Point	179051-002
R32	Resistor, 1 K Ω , $\pm 5\%$, $\frac{1}{4}$ W	110000-102	OP1L-OP3L	Conn, 6 Ckt, Hdr, .100 Ctr	179177-006
R33	Resistor, 10 K Ω , $\pm 5\%$, $\frac{1}{4}$ W	110000-103	OP1U-OP3U		
R34	Resistor, 3.3 K Ω , $\pm 5\%$, $\frac{1}{4}$ W	110000-332	OP1L-OP3L	Connector, Rcpt, 2CKT	179178-002
R35	Resistor, 8.2 K Ω , $\pm 5\%$, $\frac{1}{4}$ W	110000-822	OP1U-OP3U		
R36	Resistor, 3.3 K Ω , $\pm 5\%$, $\frac{1}{4}$ W	110000-332		Socket, 14-Pin	79-42C14
R37	Resistor, 10 K Ω , $\pm 5\%$, $\frac{1}{4}$ W	110000-103		Socket, 16-Pin	79-42C16
R38	Resistor, 3.9 K Ω , $\pm 5\%$, $\frac{1}{4}$ W	110000-392		Socket, 20-Pin	79-42C20
R39	Resistor, 10 K Ω , $\pm 5\%$, $\frac{1}{4}$ W	110000-103		Socket, 28-Pin	79-42C28
R40	Resistor, 4.7 K Ω , $\pm 5\%$, $\frac{1}{4}$ W	110000-472		Socket, 40-Pin	79-42C40

LSI Cartridge 4 PCB Assembly Parts List A043973-01 C

Designator	Description	Part No.	Designator	Description	Part No.
Integrated Circuits					
1B	IC, EPROM, 27512, 300 ns	136048-1115	11A*	IC, EPROM, 27512, 200 ns	136048-1152
1F	IC, EPROM, 27512, 300 ns	136048-1117	11C*	IC, EPROM, 27512, 200 ns	136048-1151
2B	IC, EPROM, 27512, 300 ns	136048-1111	11H	IC, Op Amp, TL084	37-347
2F	IC, EPROM, 27512, 300 ns	136048-1113	12E	IC, 74LS04	37-74LS04
3B	IC, EPROM, 27512, 300 ns	136048-1107	13A*	IC, EPROM, 27512, 200 ns	136048-1154
3F	IC, EPROM, 27512, 300 ns	136048-1109	13C*	IC, EPROM, 27512, 200 ns	136048-1153
4/5A	IC, 74S138	137174-001	13E	IC, 74LS161	37-74LS161
4A	IC, 74LS244	37-74LS244	14E	IC, EPROM, 27128, 300 ns	136048-1149
4B	IC, EPROM, 27256, 300 ns	136048-1101	15/16E	IC, EPROM, 27128, 300 ns	136048-1169
4F	IC, EPROM, 27256, 300 ns	136048-1103	16A	IC, EPROM, 27256, 200 ns	136048-1168
4H	IC, EPROM, 27256, 300 ns	136048-1105	16C	IC, EPROM, 27256, 200 ns	136048-1167
5/6D	IC, 74LS04	37-74LS04	16F/H	IC, Interface Adapter, 6522A	137260-001
5A	IC, PROM, 74S473	136048-1171	16H	IC, LPC, Voice Synthesis Processor, 5220C	137308-002
5B, 5D, 5F, 5H	IC, SLAGS	137415-101	17A	IC, EPROM, 27128, 200 ns	136048-1148
6/7A	IC, PROM, 74S472	136048-1172	17C	IC, EPROM, 27128, 200 ns	136048-1147
6A	IC, 74LS244	37-74LS244	17E	IC, EPROM, 27128, 300 ns	136048-1170
6B	IC, EPROM, 27512, 300 ns	136048-1116	18A	IC, SLAPSTIC	137412-109
6F	IC, EPROM, 27512, 300 ns	136048-1118	18C	IC, 74LS04	37-74LS04
7B	IC, EPROM, 27512, 300 ns	136048-1112	Capacitors		
7F	IC, EPROM, 27512, 300 ns	136048-1114	C1-C45	Capacitor, .1 μ F, 50 V, Ceramic	122002-104
8A	IC, 74LS30	37-74LS30	C46	Capacitor, .22 μ F, 25 V, Ceramic	122004-224
8B	IC, EPROM, 27512, 300 ns	136048-1108	C47	Capacitor, .0068 μ F, 50 V, Ceramic	122015-682
8F	IC, EPROM, 27512, 300 ns	136048-1110	C48-C52	Capacitor, .1 μ F, 50 V, Ceramic	122002-104
9A	IC, 74LS30	37-74LS30	C53	Capacitor, .22 μ F, 25 V, Ceramic	122004-224
9B	IC, EPROM, 27256, 300 ns	136048-1102	C54	Capacitor, .1 μ F, 50 V, Ceramic	122002-104
9F	IC, EPROM, 27256, 300 ns	136048-1104	C55	Capacitor, .22 μ F, 25 V, Ceramic	122004-224
9H	IC, EPROM, 27256, 300 ns	136048-1106	C56	Capacitor, .0039 μ F, 50 V, Ceramic	122015-392
10/11F	IC, 74LS00	37-74LS00	C57-C62	Capacitor, .1 μ F, 50 V, Ceramic	122002-104
10A	IC, 74LS27	37-74LS27	C63	Capacitor, .0012 μ F, 50 V, Ceramic	122015-122
10B	IC, 74LS244	37-74LS244	C64	Capacitor, .018 μ F, 50 V, Ceramic	122015-183
10F	IC, 74LS161	37-74LS161	C65	Capacitor, 100 pF, 100 V, Ceramic	122016-101
10H	IC, 74LS244	37-74LS244			

*The part number for the German version of this IC is identical except that the second digit of the suffix is a "2" instead of a "1" (i.e., 136048-x2xx).

**LSI Cartridge 4 PCB Assembly
Parts List, Continued**

Designator	Description	Part No.	Designator	Description	Part No.
C66-C78	Capacitor, .1 μ F, 50 V, Ceramic	122002-104	R28	Resistor, 3.3 K Ω , \pm 5%, 1/4 W	110000-332
C79-C90	Capacitor, 4.7 μ F, 50 V, Electrolytic	24-500475	R29	Resistor, 390 Ω , \pm 5%, 1/4 W	110000-391
C91-C93	Capacitor, 10 μ F, 35 V, Electrolytic	24-350106	R30	Resistor, 56 K Ω , \pm 5%, 1/4 W	110000-563
C94	Capacitor, 100 μ F, 25 V, Electrolytic	24-250107	R31	Resistor, 12 K Ω , \pm 5%, 1/4 W	110000-123
C96	Capacitor, .0027 μ F, 50 V, Ceramic	122015-272	R32	Resistor, 1 K Ω , \pm 5%, 1/4 W	110000-102
Transistors			R33	Resistor, 10 K Ω , \pm 5%, 1/4 W	110000-103
Q3	IC, 79L05 (Acceptable substitute is part no. 37-7905)	37-79L05	R34	Resistor, 3.3 K Ω , \pm 5%, 1/4 W	110000-332
Q4	Transistor, 2N3904	34-2N3904	R35	Resistor, 8.2 K Ω , \pm 5%, 1/4 W	110000-822
Q5, Q6	Transistor, 2N3906	33-2N3906	R36	Resistor, 3.3 K Ω , \pm 5%, 1/4 W	110000-332
Resistors			R37	Resistor, 10 K Ω , \pm 5%, 1/4 W	110000-103
R1	Resistor, 330 Ω , \pm 5%, 1/4 W	110000-331	R38	Resistor, 3.9 K Ω , \pm 5%, 1/4 W	110000-392
R2	Resistor, 220 Ω , \pm 5%, 1/4 W	110000-221	R39	Resistor, 10 K Ω , \pm 5%, 1/4 W	110000-103
R6-R9	Resistor, 4.7K \times 9 Ω , \pm 5%, 1/8 W, SIP (10-Pin)	118010-472	Miscellaneous		
R10	Resistor, 2.4 K Ω , \pm 5%, 1/4 W	110000-242	GND1,	Test Point	179051-001
R12-R14	Resistor, 4.7K \times 9 Ω , \pm 5%, 1/8 W, SIP (10-Pin)	118010-472	GND2		
R20	Resistor, 10 K Ω , \pm 5%, 1/4 W	110000-103	+5V1, +5V2		
R21	Resistor, 5.6 K Ω , \pm 5%, 1/4 W	110000-562	OP4-OP6	Conn, 6 Ckt, Hdr, .100 Ctr	179177-006
R22	Resistor, 10 K Ω , \pm 5%, 1/4 W	110000-103	OP1L-OP3L		
R23	Resistor, 43 K Ω , \pm 5%, 1/4 W	110000-433	OP1U-OP3U		
R24, R25	Resistor, 20 K Ω , \pm 5%, 1/4 W	110000-203	OP4-OP6	Conn, Rcpt, 2 Ckt	179178-001
R26	Resistor, 43 K Ω , \pm 5%, 1/4 W	110000-433	OP1L-OP3L		
R27	Resistor, 1.8 K Ω , \pm 5%, 1/4 W	110000-182	OP1U-OP3U		
				Socket, 14-Pin	79-42C14
				Socket, 20-Pin	79-42C20
				Socket, 28-Pin	79-42C28
				Socket, 40-Pin	79-42C40

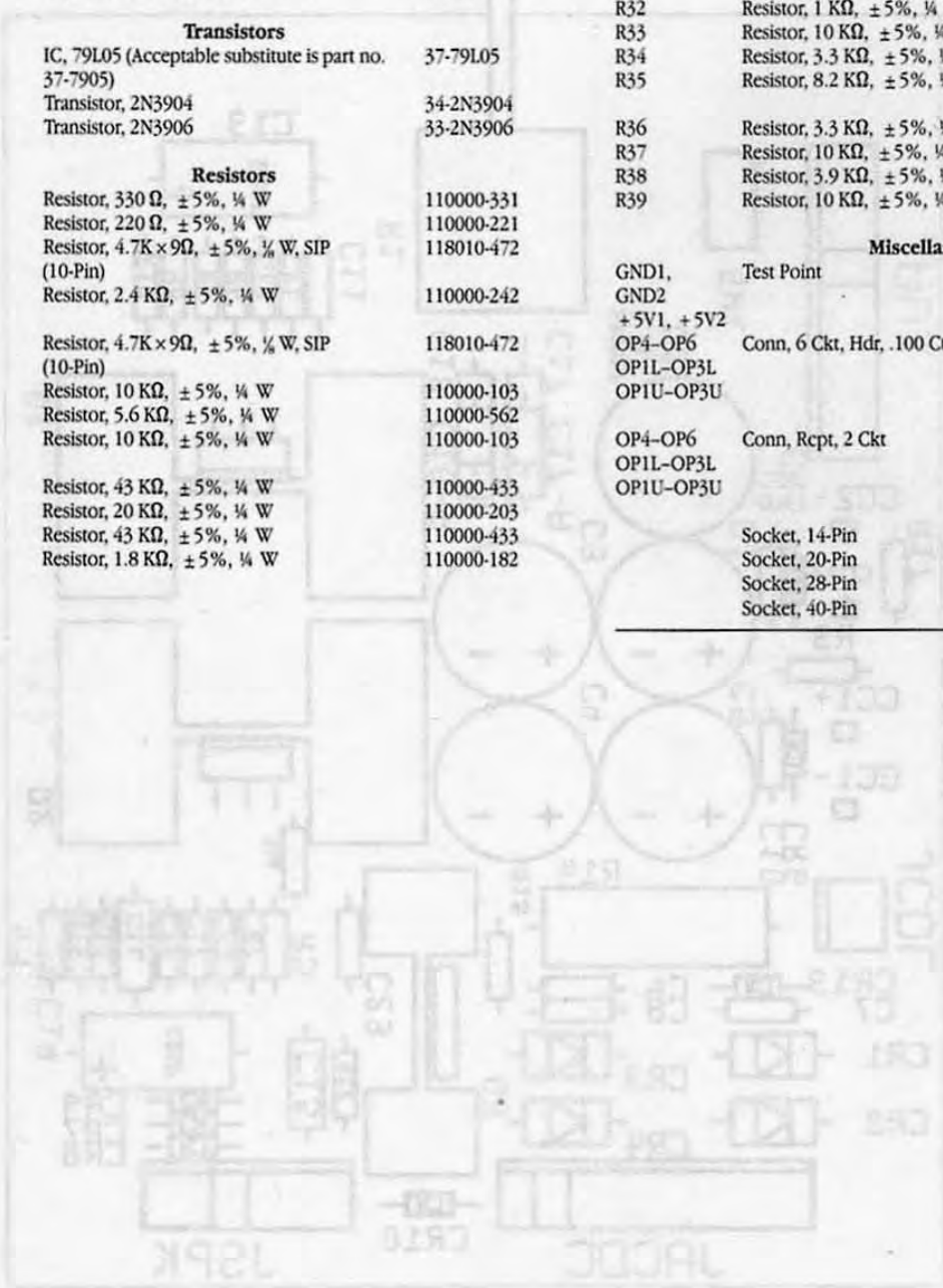
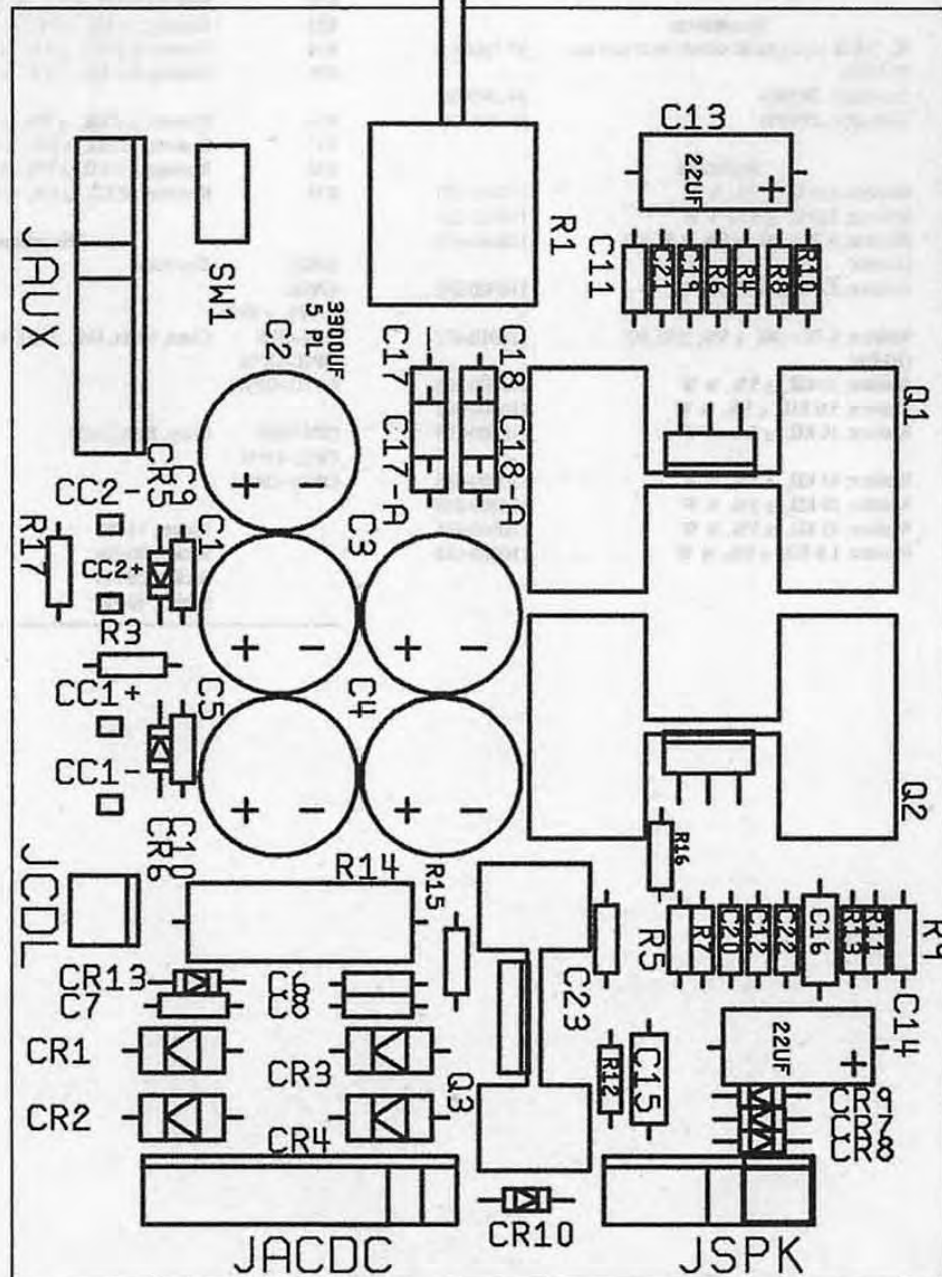
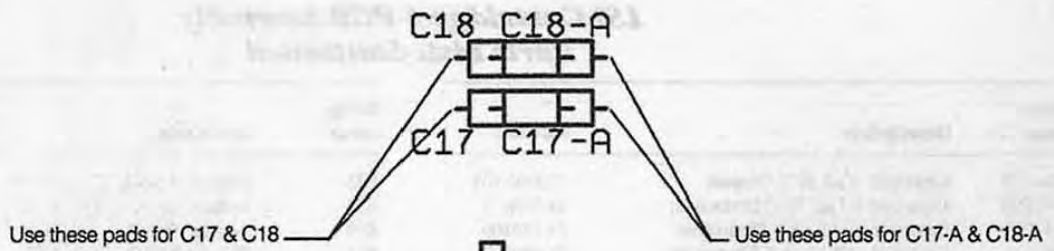

Figure 2-11 - Analog II PCB Assembly
4088821-01 D



NOTICE TO ALL PERSONS RECEIVING THIS DRAWING
 CONFIDENTIAL: Reproduction forbidden without the specific written permission of Alan Games Corporation, Milpitas, CA. This drawing is only conditionally issued, and neither receipt nor possession thereof confers any right in, or license to use, the subject matter of the drawing or any design or technical information shown thereon, nor any right to reproduce this drawing or any part thereof. Except for manufacture by vendors of Alan Games Corporation, and for manufacture under the corporation's written license, no right is granted to reproduce this drawing or the subject matter thereof, unless by written agreement with or written permission from the corporation.

Figure 5-11 Audio II PCB Assembly
A043661-02 D

Audio II PCB Assembly Parts List

Designator	Description	Part No.
Capacitors		
C1-C5	3300 μ F, 25 V Radial Electrolytic Capacitor	123003-338
C6-C12	.1 μ F, 50 V Ceramic Capacitor	122002-104
C13, C14	22 μ F, 35 V Electrolytic Capacitor	24-350226
C15-C18	.22 μ F, 25 V Ceramic Capacitor	122006-224
C19, C20	.001 μ F, 50 V Ceramic Capacitor	122002-102
C21-C23	.1 μ F, 50 V Ceramic Capacitor	122002-104
Diodes		
CR1-CR4	Type-1N5401 Diode	31-1N5401
CR5-CR10	Type-1N4001 Diode	31-1N4001
CR13	Type-1N4002 Diode	31-1N4002
Connectors		
JACDC	Key 6, 9 Ckt., .156-Inch Ctr. Header Connector	179213-009
JAUX	Key 6, 9 Ckt., .156-Inch Ctr. Header Connector	179213-009
JCDL	2 Ckt., .156-Inch Ctr. Header Connector	179213-002
JSPK	Key 3, 6 Ckt., .156-Inch Ctr. Header Connector	179213-006
Integrated Circuits		
Q1, Q2	Type-TDA-2030 Amplifier	137301-001
Q3	Standup Type-7812 Integrated Circuit	37-7812
Resistors		
R1	10 k Ω , Dual Horizontal Pot Resistor	119011-103
R3	10 Ω , \pm 5%, 1/4 W Resistor	110000-100
R4-R7	22 k Ω , \pm 5%, 1/4 W Resistor	110000-223
R8, R9	10 k Ω , \pm 5%, 1/4 W Resistor	110000-103
R10-R11	1 k Ω , \pm 5%, 1/4 W Resistor	110000-102
R12, R13	1 Ω , \pm 5%, 1/4 W Resistor	110000-010
R14, R17	0 Ω , \pm 5%, 1/4 W Resistor	110005-001
Miscellaneous		
SW1	SPDT Miniature Slide Self-Test Switch	69-004
	Type-TDA-2030 Heat Sink	178190-032
	#6-32 \times 1/8-Inch Cross-Recessed Pan-Head Screw	72-1606S
	#6-32 Nut/Washer Assembly	75-99516
	Thermal Compound	78-16001
	Hot Melt Adhesive	106006-001
	Test Point	179051-001

Kit Installation

Your Road Blasters™ game uses the System I™ cabinet designed to accept the necessary hardware to easily convert the cabinet into a variety of games. This chapter contains information that applies to those parts of your existing System I cabinet that are added or replaced to convert the cabinet to a Road Blasters game. (See Figure 6-1.) The conversion instructions include: (1) replacing the attraction film, control panel, and game Cartridge Printed-Circuit Board (PCB); (2) installing two bolts to strengthen the control panel assembly; (3) installing the foot pedal assembly and installing the cabinet control harness assembly, and (4) cleaning the video display. See Figure 6-1 for the locations of the parts of the System I cabinet that are replaced, installed, and cleaned.

Wiring and schematic diagrams for the Road Blasters game are contained in the *Schematic Package Supplement* (SP-298) included with your game.

Kit Parts Inventory

The assemblies listed in Table 6-1 are included in the Road Blasters Conversion Kit. Refer to Chapter 5, Illustrated Parts List, for a description of the component parts comprising the control panel, foot pedal, and LSI Cartridge PCB listed in Table 6-1.

Tools Required

The only tools required to perform a complete Road Blasters conversion are: Phillips screwdriver, $\frac{1}{8}$ -inch hex driver, $\frac{7}{16}$ -inch nut driver, $\frac{1}{16}$ -inch open-end wrench, awl, hammer, drill, $\frac{1}{16}$ -inch drill bit, $\frac{3}{8}$ -inch drill bit, 1 $\frac{1}{2}$ -inch spade bit, and Scotch tape (or stapler). (A $\frac{3}{8}$ -inch wrench is also required if your game has a vertically mounted video display.)

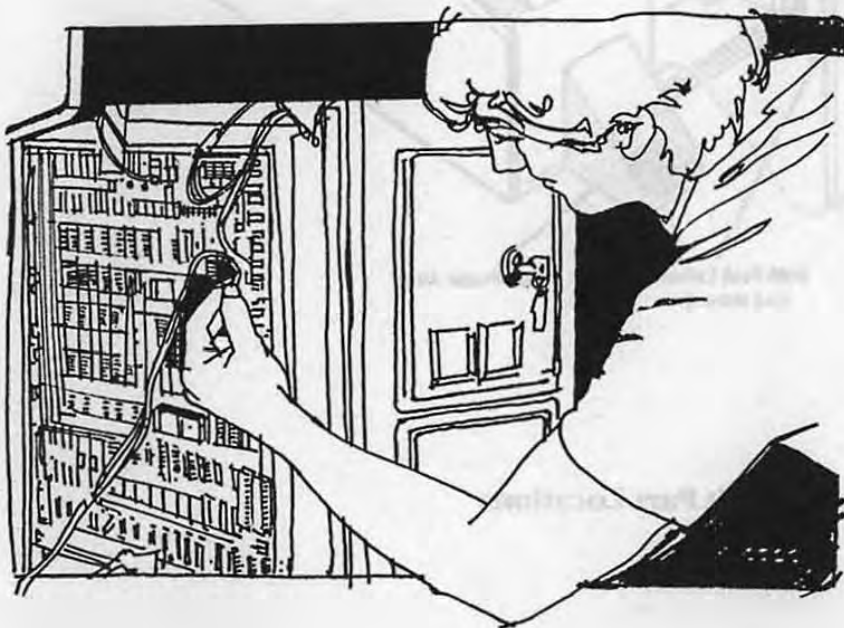

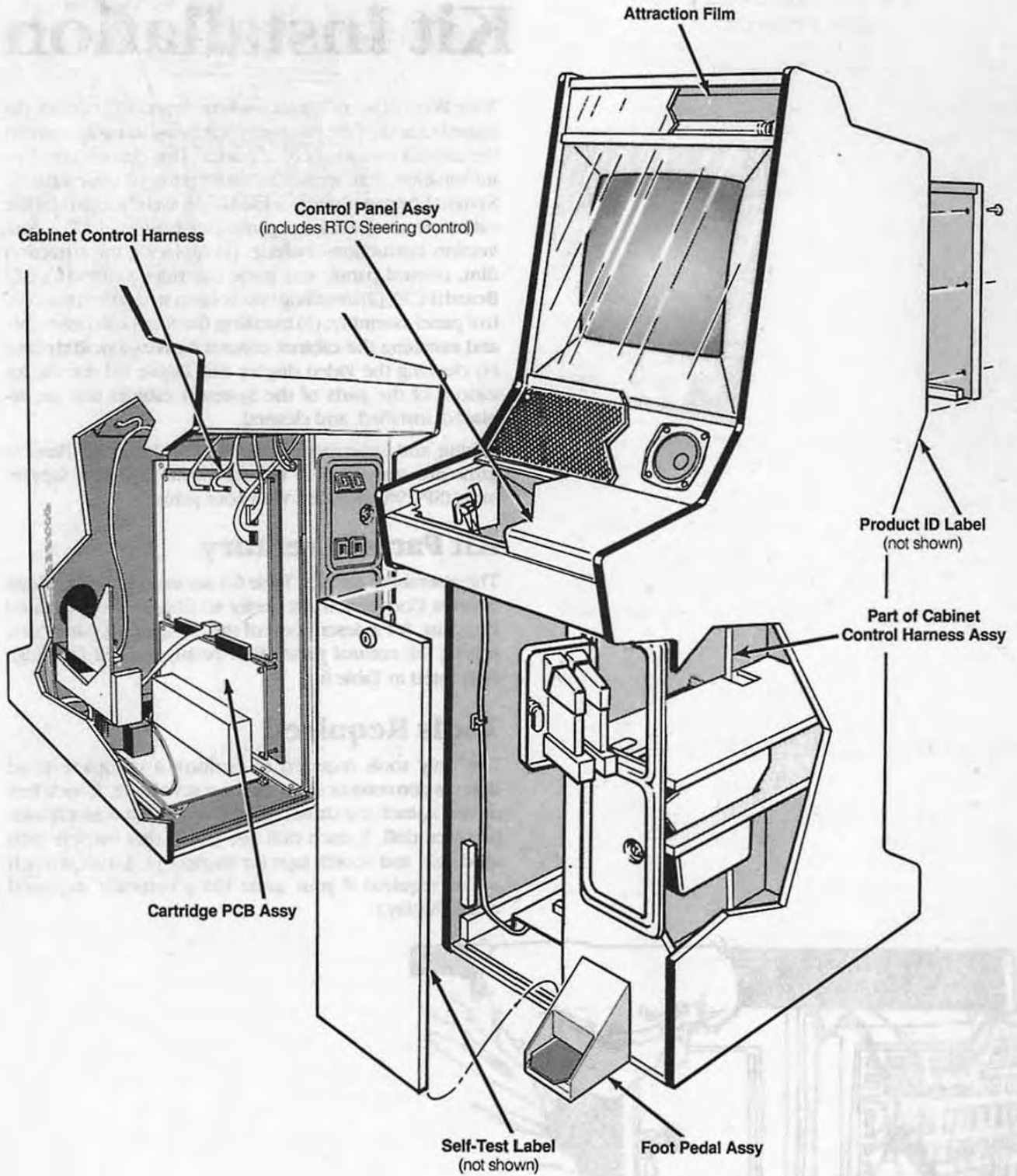

Figure 6-1 Kit Part Locations

**Table 6-1 Road Blasters
Kit Parts Inventory
A043956-xx**

Part No.	Quantity	Description
A043825-01	1	Foot Pedal Assembly
A043941-01	1	Cabinet Control Harness Assembly
A043957-02	1	Control Panel Assembly
A043972-01 or A043973-01	1	LSI Cartridge 3 PCB Assembly or LSI Cartridge 4 PCB Assembly
75-010F	2	#10 Black Flat Washer
75-015S	4	# $\frac{1}{4}$ -Inch Flat Washer
75-050B	2	#10 Black Internal Tooth Washer
82-8120B	2	#10-24 x $1\frac{1}{4}$ -Inch Black Button-Head Hex-Socket Machine Screw
038158-01	1	Product Identification Label—Non-UL (042465-01 \star)
043961-01	1	Foot Pedal Mounting Template
043961-02	1	Control Panel Mounting Template
044324-01	1	Contest Marquee
044392-01	1	Attraction Film with Graphics
177010-244	4	# $\frac{1}{4}$ -20 Hex Lock Nut
TM-298	1	Operators Manual
SP-298	1	Schematic Package Supplement
ST-298	1	Self-Test Label

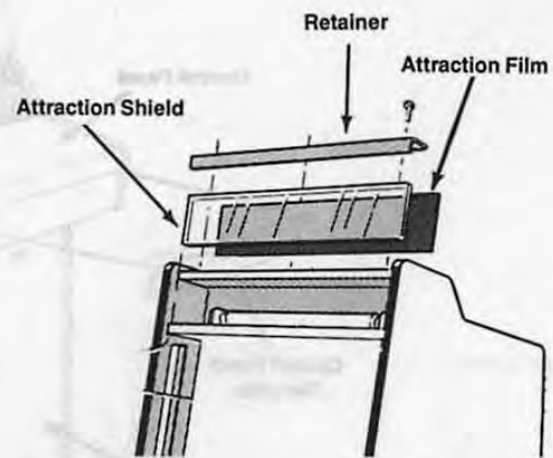

Figure 6-2 Attraction Film Replacement

1. Turn off the game power.
2. Using a $\frac{1}{8}$ -inch hex driver, remove the three screws and washers holding the upper retainer to the top of the cabinet.
3. Grasp the top edge of the existing attraction film behind the attraction shield and slide it up to remove.
4. Install the Road Blasters attraction film. Make sure the film is fully inserted into the bottom slot.
5. Remount the upper retainer.

Conversion Instructions



WARNING

To avoid electrical shock, unplug the game before performing the conversion procedures.

The following procedures are arranged in the sequence recommended for performing the game conversion. The parts of your cabinet that are affected by the conversion are removed first and then replaced by the new Road Blasters kit parts.

NOTE

The following conversion should be performed by qualified service personnel.

Replace the Attraction Film

Perform the following procedure to remove/replace the existing attraction film with the Road Blasters attraction film. (See Figure 6-2).

Remove the Control Panel

Perform the following procedure to remove/replace the existing control panel with the Road Blasters control panel. (See Figure 6-3).

1. Unlock and open the coin door on the front of the cabinet.
2. Carefully reach through the coin door opening and release the spring-draw latch located under the control panel on the right side of the cabinet.
3. Unlock and remove the front access panel.
4. Reach through the front access panel opening and disconnect the control panel harness from the top of the Main PCB Assembly.
5. Carefully reach up under the top of the front access panel opening and release the spring-draw latch located under the control panel on the left side of the cabinet.
6. From underneath, push up on the front edge of the control panel to free the panel from the slot in the cabinet.
7. Carefully lift the control panel from the cabinet.

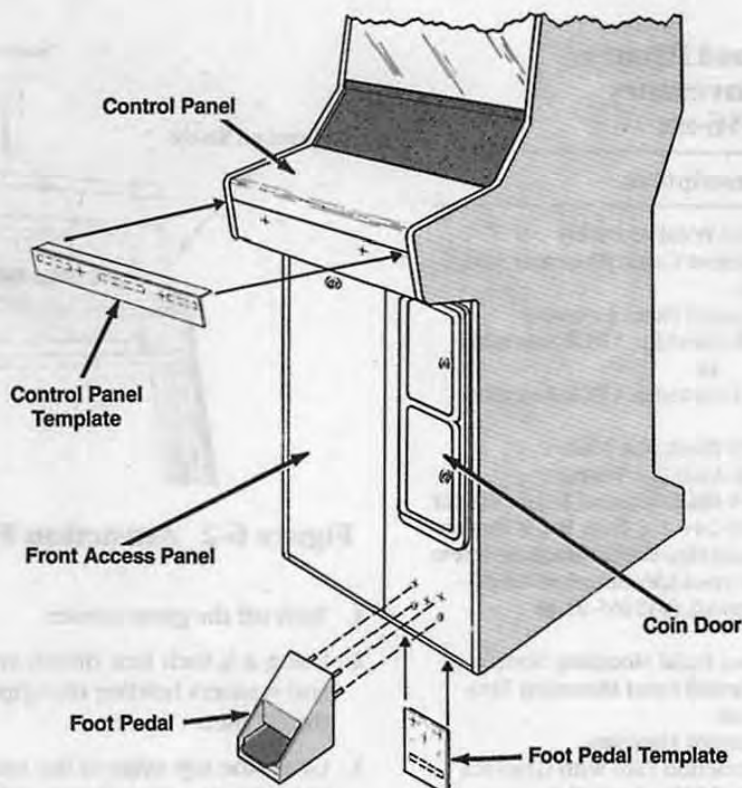

Figure 6-3 Control Panel and Foot Pedal Installation

8. Disconnect the green ground wire from the control panel harness.

Clean the Video Display Glass

Static electricity attracts dust to the video display glass and can cause the video image to grey out, making the screen colors appear faded. In order to prevent this from happening, the video display glass must be cleaned. Perform the following procedure to clean the display glass.

1. Using a $\frac{1}{8}$ -inch hex driver, remove the two screws holding the lower retainer to the cabinet.
2. Grasp the display shield on the bottom edge and gently pull it out about one half inch from the cabinet.
3. Gently lower the display shield to free the top edge from under the speaker grille.
4. Using a glass cleaner, clean the display glass and the monitor screen. Be sure to avoid spraying the bezel.
5. Replace the display shield in the reverse order of removal.

Install the Cabinet Control Harness

Perform the following procedure to install the cabinet control harness. (See Figure 6-1.)

1. Remove the existing control harness.

2. Plug the cabinet control harness connectors P102, P106, and P103 into the Main PCB at J102, J106, and J103, matching keyed connectors with keyed PCB headers.
3. Connect the two mating green ground wires to each other.

Install the Control Panel Bolts

Perform the following procedure to install two control panel bolts to strengthen the control panel. (See Figure 6-3.)

1. Remove the control panel as described earlier in this chapter.
2. Remove the protective backing from the control panel mounting template (Atari part no. 043961-02).
3. Align the side edges of the template along the inside edges of the cabinet side panel.
4. With the template properly positioned, use an awl and hammer to make an indentation on the two cross marks shown on the template. Remove the template.
5. Use a $\frac{3}{16}$ -inch drill bit and drill a hole at each indentation.
6. Plug the 12-position harness connector P24 into the control panel harness connector.

7. Install the Road Blasters control panel. (Be sure to securely fasten the two spring-draw latches under the control panel.)
8. Insert a 1/4-inch black bolt, internal-tooth washer, and flat washer into each hole and tighten with a 1/8-inch hex driver. (The bolts and washers are supplied with the kit.)
5. Connect the Road Blasters Cartridge PCB to the Main PCB. Make sure that the Cartridge PCB is fully inserted into the Main PCB edge connectors.
6. Replace the four thumbscrews on the Cartridge PCB. See Figure 6-1 for the locations of the printed-circuit boards. In order for this game to comply with Federal Communications Commission regulations, these thumbscrews must be tight. The Cartridge PCB must be securely connected to the ground plane.

Install the Foot Pedal

The Road Blasters game uses a foot pedal. Perform the following procedure to install the foot pedal. (See Figure 6-3.)

1. Remove the protective backing from the foot pedal mounting template (Atari part no. 043961-01).
2. Remove the two carriage bolts from the bottom right corner of the cabinet coin door panel.
3. Align the two holes of the template with the two holes in the bottom right corner of the cabinet coin door panel.
4. With the template properly positioned, use an awl and hammer to make an indentation on the three cross marks shown on the template. Remove the template.
5. Use a 3/8-inch drill bit and drill a hole at each corner indentation.
6. Use a 1 1/2-inch spade bit and drill a hole at the center indentation.
7. Insert the foot pedal harness assembly through the center hole.
8. Insert the four bolts of the foot pedal assembly into the four corner holes.
9. Use a 7/16-inch nut driver to tighten the four lock nuts and flat washers of the bolts. (The nuts and washers are supplied with the kit.)
10. Connect the foot pedal harness to the cabinet control harness.

Replace the Cartridge PCB

Perform the following procedure to remove/replace the existing game Cartridge PCB and replace with the Road Blasters Cartridge PCB. (See Figure 6-1.)

1. Turn the cabinet power off.
2. Unlock and remove the front access panel from the cabinet.
3. Turn the four thumbscrews that hold the existing Cartridge PCB to the ground plane. (Some System I games might have Phillips screws.)
4. Gently disconnect the Cartridge PCB from the Main PCB.

NOTE

The procedure for removing the Main PCB is included in Chapter 5 of this manual.

Install the Self-Test Label

Staple or tape the Road Blasters Self-Test Label on the inside of the front access panel.

Install the Product Identification Label

Perform the following procedure to install the Road Blasters product identification label.

1. Remove the protective backing from the Road Blasters product identification label.
2. Place the Road Blasters product identification label over the existing product identification label on the back of the cabinet.

Inspect the Game

Before applying power, perform the following inspection procedure.

1. Carefully check that the Road Blasters conversion kit parts have been properly installed. Check that the game Cartridge PCB has been properly installed. Make sure that the control-panel harness connector is tightly connected to the cabinet control harness connector, and that the spring draw latches under the control panel are securely fastened.
2. Plug in the game power cord.
3. Perform the self-test procedure as given in Chapter 2. If the self-test indicates that the video display requires adjustment, perform the adjustment procedures described in the video display manual included with your game. (If the roadway or car pictures are distorted, repeat the Cartridge PCB removal procedure.)
4. Be sure to reset the high score table and the accounting information, or game statistics. Refer to the procedure in *Reset the High Score Table and the Accounting Information* later in this chapter.

- 5. Close and lock the front access panel.

Setting the Coin and Game Options

The Road Blasters coin and game options are set in the Self-Test Mode. Refer to Chapter 2 for the recommended settings and the procedure for setting the options.

Reset the High Score Table and the Accounting Information

The high score table and the accounting information, or game statistics, must be reset after completing the con-

version to ensure accurate game data. This information is displayed on the Accounting Information screen in the Self-Test Mode. (Refer to *Accounting Information* in Chapter 2.) Perform the following procedure to reset this information.

1. Enter the Self-Test Mode by turning on the self-test switch, and press the thumb button on the RTC steering control until the Statistics screen is displayed.
2. Press the foot pedal to reset the accounting information.

Install the Self-Test Label

Apply the self-test label to the front panel of the cabinet.

Install the Product Identification Label

Apply the product identification label to the front panel of the cabinet.

Remove the cover from the coin slot.

Press the coin slot button to reset the coin slot.

Support the Cabinet

Support the cabinet from the rear.

Check the cabinet level. The cabinet should be level. If it is not level, adjust the feet. The feet are located at the bottom of the cabinet. Turn the feet clockwise to raise the cabinet and counter-clockwise to lower it.

Turn on the power switch.

Enter the self-test mode. Press the self-test switch on the front panel of the cabinet. The self-test mode is entered when the RTC steering control is pressed.

Press the foot pedal to reset the accounting information.

Remove the cover from the coin slot.

Press the coin slot button to reset the coin slot.

Press the thumb button on the RTC steering control until the Statistics screen is displayed.

Press the foot pedal to reset the accounting information.

Remove the cover from the coin slot.

Press the coin slot button to reset the coin slot.

Press the thumb button on the RTC steering control until the Statistics screen is displayed.

Press the foot pedal to reset the accounting information.

Remove the cover from the coin slot.

Press the coin slot button to reset the coin slot.

Replace the Cartridge PCB

Remove the cartridge PCB from the cabinet. The cartridge PCB is located in the front panel of the cabinet.

Insert the new cartridge PCB into the cabinet. The new cartridge PCB is located in the front panel of the cabinet.

Remove the cover from the coin slot.

Press the coin slot button to reset the coin slot.

Road Blasters™

Coin Information and Game Statistics

Date: _____

Aux Coins	_____	Not used in Road Blasters game
Left Coins	_____	Number of coins deposited in left coin mechanism
Right Coins	_____	Number of coins deposited in right coin mechanism
1 Plyr Games	_____	Number of 1-player games
Mins Played	_____	Total time, in minutes, of all games played
Mins Pwr Up	_____	Total time, in minutes, that the game has been turned on
Aux Cntr 1	_____	Highest rally achieved
Aux Cntr 2	_____	Total number of times add-a-coin continuation used
Aux Cntr 3	_____	Number of games without a new entry into top four scores
Error Count	_____	Number of EEPROM errors
Avg. Game Time	_____	Average game time in seconds (including add-a-coin continuation games)

Histogram Information

Length of Game in Seconds	Number of Games That Reached Level				
	1	2	3	4	5
0-59	_____	_____	_____	_____	_____
60-89	_____	_____	_____	_____	_____
90-119	_____	_____	_____	_____	_____
120-149	_____	_____	_____	_____	_____
150-179	_____	_____	_____	_____	_____
180-209	_____	_____	_____	_____	_____
210-239	_____	_____	_____	_____	_____
240-269	_____	_____	_____	_____	_____
270-299	_____	_____	_____	_____	_____
300-329	_____	_____	_____	_____	_____
330-359	_____	_____	_____	_____	_____
360-389	_____	_____	_____	_____	_____
390-419	_____	_____	_____	_____	_____
420-449	_____	_____	_____	_____	_____
450-479	_____	_____	_____	_____	_____
480-509	_____	_____	_____	_____	_____
510-539	_____	_____	_____	_____	_____
540 & up	_____	_____	_____	_____	_____
High Score	_____	_____	_____	_____	_____

Histogram Levels 1-3:
Number of games that started at the Rookie, Veteran, or Expert level, respectively. These are only games that were played without using the game continuation feature.

Histogram Level 4:
Number of games that ended on the original level for add-a-coin game continuation.

Histogram Level 5:
Number of games that ended on a higher level after a game continuation.

Road Blasters

Coin Information and Game Statistics

Date: _____

Average game time in seconds (including add-a-life feature)
 Number of BUBBLES eaten
 Number of games without a new entry into the top scores
 Total number of rows with a coin contained on board
 Highest jelly achieved
 Total time in minutes that the game has been played
 Number of 1 player games
 Number of rows destroyed in right column of board
 Number of rows destroyed in left column of board
 Total score in Road Blasters game

Top Game Time
 Total Cost
 Add Coin 1
 Add Coin 2
 Add Coin 3
 Add Coin 4
 Add Coin 5
 Add Coin 6
 Add Coin 7
 Add Coin 8
 Add Coin 9
 Add Coin 10

Histogram Information

Length of Game in Seconds	Number of Games That Reached Level				
	1	2	3	4	5
0-20					
20-30					
30-40					
40-50					
50-60					
60-70					
70-80					
80-90					
90-100					
100-110					
110-120					
120-130					
130-140					
140-150					
150-160					
160-170					
170-180					
180-190					
190-200					
200-210					
210-220					
220-230					
230-240					
240-250					
250-260					
260-270					
270-280					
280-290					
290-300					
300-310					
310-320					
320-330					
330-340					
340-350					
350-360					
360-370					
370-380					
380-390					
390-400					
400-410					
410-420					
420-430					
430-440					
440-450					
450-460					
460-470					
470-480					
480-490					
490-500					
500-510					
510-520					
520-530					
530-540					
540-550					
550-560					
560-570					
570-580					
580-590					
590-600					
600-610					
610-620					
620-630					
630-640					
640-650					
650-660					
660-670					
670-680					
680-690					
690-700					
700-710					
710-720					
720-730					
730-740					
740-750					
750-760					
760-770					
770-780					
780-790					
790-800					
800-810					
810-820					
820-830					
830-840					
840-850					
850-860					
860-870					
870-880					
880-890					
890-900					
900-910					
910-920					
920-930					
930-940					
940-950					
950-960					
960-970					
970-980					
980-990					
990-1000					

High score: _____

Histogram Level 1-5
 Number of games that reached the level
 Level of game that reached the highest score
 Total number of games that reached the highest score

Histogram Level 6
 Number of games that reached the highest score
 Level of game that reached the highest score

Histogram Level 7
 Number of games that reached the highest score
 Level of game that reached the highest score

Glossary

AC

Alternating current; from zero it rises to a maximum positive level, then passes through zero again to a maximum negative level.

ACTIVE STATE

The true state of a signal. For example: The active state for $\overline{\text{START}}$ is low.

ADDRESS

A value that identifies a specific location of data in memory; normally expressed in hexadecimal notation.

ANALOG

Measurable in an absolute quantity (as opposed to on or off). Analog devices are volume controls, light dimmers, stereo amplifiers, etc.

ANODE

The positive (arrow) end of a diode.

AMPLIFIER

A device used to increase the strength of an applied signal.

AMPLITUDE

The maximum instantaneous value of a waveform pulse from zero.

ASTABLE

Having no normal state. An astable device will free-run or oscillate as long as operating voltage is applied. The oscillation frequency is usually controlled by external circuitry.

AUXILIARY COIN SWITCH

A momentary-contact pushbutton switch with a black cap located on the utility panel. The auxiliary coin switch adds credits to the game without activating a coin counter.

BEZEL

A cut, formed, or machined retention device, such as the conical device used to mount a pushbutton switch to a control panel, or the formed device used to frame the video display screen.

BIDIRECTIONAL

Able to send or receive data on the same line (e.g., the data bus of a microprocessor).

BINARY

A number system that expresses all values by using two digits (0 and 1).

BIT

A binary digit; expressed as 1 or 0.

BLANKING

Turning off the beam on a cathode-ray tube during retrace.

BLOCK DIAGRAM

A drawing in which functional circuitry units are represented by blocks. Very useful during initial troubleshooting.

BUFFER

1. An isolating circuit designed to eliminate the reaction of a driven circuit on the circuits driving it (e.g., a buffer amplifier).

2. A device used to supply additional drive capability.

BUS

An electrical path over which information is transferred from any of several sources to any of several destinations.

CAPACITOR

A device capable of storing electrical energy. A capacitor blocks the flow of DC current while allowing AC current to pass.

CATHODE

The negative end of a diode.

CHIP

An integrated circuit comprising many circuits on a single wafer slice.

CLOCK

A repetitive timing signal for synchronizing system functions.

COINCIDENCE

Occurring at the same time.

COIN COUNTER

A 6-digit electromechanical device that counts the coins inserted in the coin mechanism(s).

COIN MECHANISM

A device on the inside of the coin door that inspects the coin to determine if the correct coin has been inserted.

COMPLEMENTARY

Having opposite states, such as the outputs of a flip-flop.

COMPOSITE SYNC

Horizontal and vertical synchronization pulses that are bused together into a single signal. This signal provides the timing necessary to keep the display in synchronization with the game circuitry.

COMPOSITE VIDEO

Complete video signal from the game system to drive the display circuitry, usually comprising H SYNC, V SYNC, and the video.

CREDIT

One play for one person based on the game switch settings.

CRT

Cathode-ray tube.

DATA

General term for the numbers, letters, and symbols that serve as input for device processing.

DARLINGTON

A two-transistor amplifier that provides extremely high gain.

DC

Direct current, meaning current flowing in one direction and of a fixed value.

DEFLECTION YOKE

Electromagnetic coils around the neck of a cathode-ray tube. One set of coils deflects the electron beam horizontally and the other set deflects the beam vertically.

DIAGNOSTICS

A programmed routine for checking circuitry. For example: the self-test is a diagnostic routine.

DIODE

A semiconductor device that conducts in only one direction.

DISCRETE

Non-integrated components, such as resistors, capacitors, and transistors.

DMA

Direct memory access. DMA is a process of accessing memory that bypasses the microprocessor logic. DMA is normally used for transferring data between the input/output ports and memory.

DOWN TIME

The period during which a game is malfunctioning or not operating correctly due to machine failure.

EAROM

Electrically alterable read-only memory (see ROM). The EAROM is a memory that can be changed by applying high voltage.

EPROM

Erasable programmable read-only memory (see ROM).

FLYBACK

A step-up transformer used in a display to provide the high voltage.

GATE

1. A circuit with one output that responds only when a certain combination of pulses is present at the inputs.
2. A circuit in which one signal switches another signal on and off.
3. To control the passage of a pulse or signal.

HARNESS

A prefabricated assembly of insulated wires and terminals ready to be attached to a piece of equipment.

HEXADECIMAL

A number system using the equivalent of the decimal number 16 as a base. The symbols 0-9 and A-F are usually used.

HISTOGRAM

A special type of bar graph that shows how quantities are distributed. Histograms are included in the self-test of most Atari games, and typically show how long players play that game.

IC

Integrated circuit. An electronic circuit in which all elements and the connections are made in or on a single semiconductor substrate. See also *chip*.

IMPLODE

To burst inward; the inward collapse of a vacuum tube.

I/O

Input/Output.

IRQ

Interrupt request. IRQ is a control signal to the microprocessor that is generated by external logic. This signal tells the microprocessor that external logic needs attention. Depending on the program, the processor may or may not respond.

LED

The abbreviation for a light-emitting diode.

LOCKOUT COIL

Directs coins into the coin return box when there is no power to the game.

LOGIC STATE

The binary (1 or 0) value at the node of a logic element or integrated circuit during a particular time. Also called the logic level. The list below shows the voltage levels corresponding to the logic states (levels) in a TTL system.
Logic 0, Low = 0 VDC to +0.8 VDC
Grey Area (Tri-State Level) = +0.8 VDC to +2.4 VDC
Logic 1, High = +2.4 VDC to +5 VDC

MULTIPLEXER

A device that takes several low-speed inputs and combines them into one high-speed data stream for simultaneous transmission on a single line.

NMI

Non-maskable interrupt. NMI is a request for service by the microprocessor from external logic. The microprocessor cannot ignore this interrupt request.

PAGE

A subsection of memory. A read-only memory device (see ROM) is broken into discrete blocks of data. These blocks are called pages. Each block has X number of bytes.

PCB

The abbreviation for a printed-circuit board.

PHOTOTRANSISTOR

A transistor that is activated by an external light source.

POTENTIOMETER

1. A resistor that has a continuously moving contact which is generally mounted on a moving shaft. Used chiefly as a voltage divider. Also called a *pot* (slang).

2. An instrument for measuring a voltage by balancing it against a known voltage.

RAM

Random-access memory. A device for the temporary storage of data.

RASTER-SCAN DISPLAY

A display system whereby images are displayed by continuously scanning the cathode-ray tube horizontally and vertically with an electron beam. The display system controls the intensity of the electron beam.

RETRACE

In a raster-scan display, retrace is the time during which the cathode-ray tube electron beam is resetting either from right to left or from bottom to top.

RESISTOR

A device designed to have a definite amount of resistance. Used in circuits to limit current flow or to provide a voltage drop.

ROM

Read-only memory. A device for the permanent storage of data.

SIGNATURE ANALYSIS

A process of isolating digital logic faults at the component level by means of special test equipment called signature analyzers. Basically, signature analyzers (e.g., the ATARI® CAT Box) convert lengthy bit streams into four-digit hexadecimal signatures. The signature read by the analyzer at each circuit node is then compared with the known good signature for that node. This process continues until a fault is located.

TROUBLESHOOT

The process of locating and repairing a fault.

VECTOR

A line segment drawn between specific X and Y coordinates on a cathode-ray tube.

WATCHDOG

A counter circuit designed to protect the microprocessor from self-destruction if a program malfunction occurs. If a malfunction does occur, the counter applies continuous pulses to the reset line of the microprocessor, which causes the microprocessor to keep resetting.

X-Y DISPLAY

A display system whereby images are displayed with vectors.

ZENER DIODE

A special diode used as a regulator. Its main characteristic is breaking down at a specified reverse-bias (Zener) voltage.

Warranty

Seller warrants that its printed-circuit boards and parts thereon are free from defects in material and workmanship under normal use and service for a period of ninety (90) days from date of shipment. Seller warrants that its video displays and laser video disc players (in games supplied with displays and video-disc players) are free from defects in material and workmanship under normal use and service for a period of thirty (30) days from date of shipment. None of the Seller's other products or parts thereof are warranted.

If the products described in this manual fail to conform to this warranty, Seller's sole liability shall be, at its option, to repair, replace, or credit Buyer's account for such products which are returned to Seller during said warranty period, provided:

- (a) Seller is promptly notified in writing upon discovery by Buyer that said products are defective;
- (b) Such products are returned prepaid to Seller's plant; and
- (c) Seller's examination of said products discloses to Seller's satisfaction that such alleged defects existed and were not caused by accident, misuse, neglect, alteration, improper repair, installation, or improper testing.

In no event shall Seller be liable for loss of profits, loss of use, incidental or consequential damages.

Except for any express warranty set forth in a written contract between Seller and Buyer which contract supersedes the terms herein, this warranty is expressed in lieu of all other warranties expressed or implied, including the implied warranties of merchantability and fitness for a particular purpose, and of all other obligations or liabilities on the Seller's part, and it neither assumes nor authorizes any other person to assume for the Seller any other liabilities in connection with the sale of products by Seller.

The use of any non-Atari parts may void your warranty, according to the terms of the warranty. The use of any non-Atari parts may also adversely affect the safety of your game and cause injury to you and others. Be very cautious in using non-Atari-supplied components with our games, in order to ensure your safety.

Atari distributors are independent, being privately owned and operated. In their judgment they may sell parts or accessories other than Atari parts or accessories. Atari Games Corporation cannot be responsible for the quality, suitability or safety of any non-Atari part or any modification including labor which is performed by such distributor.



Atari Games Corporation
675 Sycamore
P.O. Box 361110
Milpitas, California 95035