

## **VII Schematics and Wiring Diagrams**

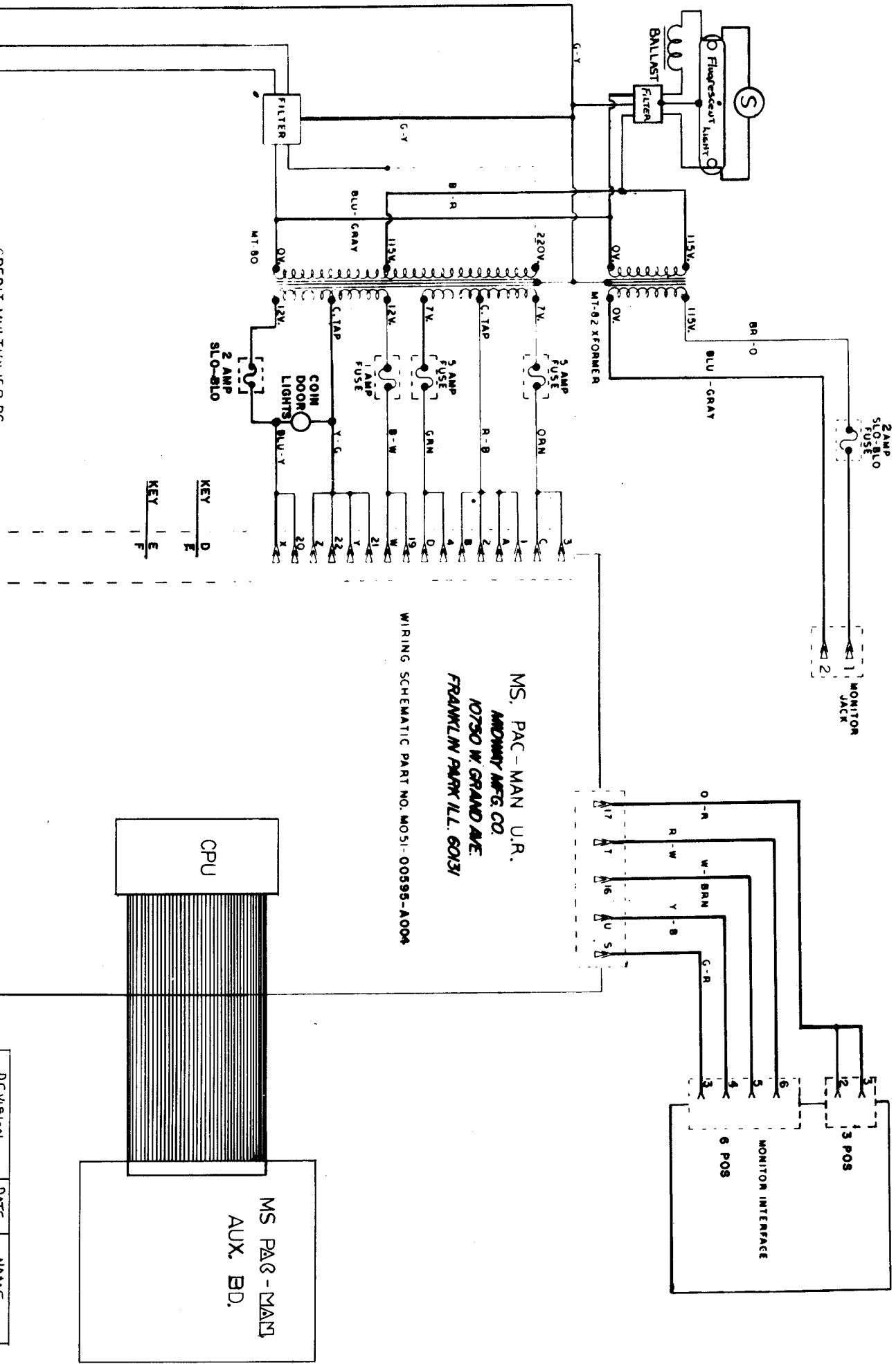

KEY  
D  
E  
F

KEY  
E  
F

MS. PAC-MAN U.R.  
AMOMY MFG CO.  
10750 W. GRAND AVE.  
FRANKLIN PARK ILL. 60131  
WIRING SCHEMATIC PART NO. MOSI-00595-A004

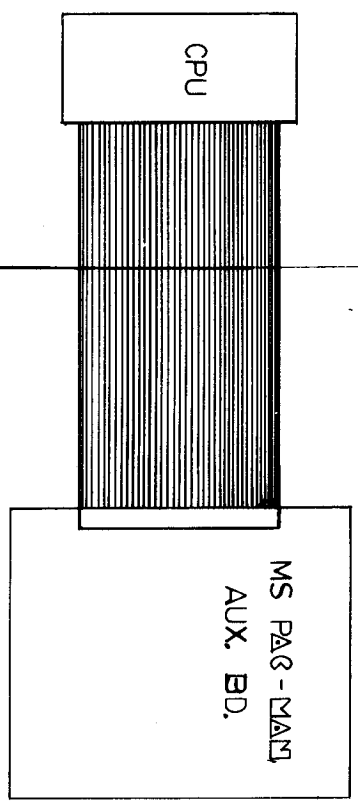

REVISION #	DATE	NAME
1	2/7/81	V. CARPUSO

GAME LOGIC BOARD  
P.C. A082-91375-A000

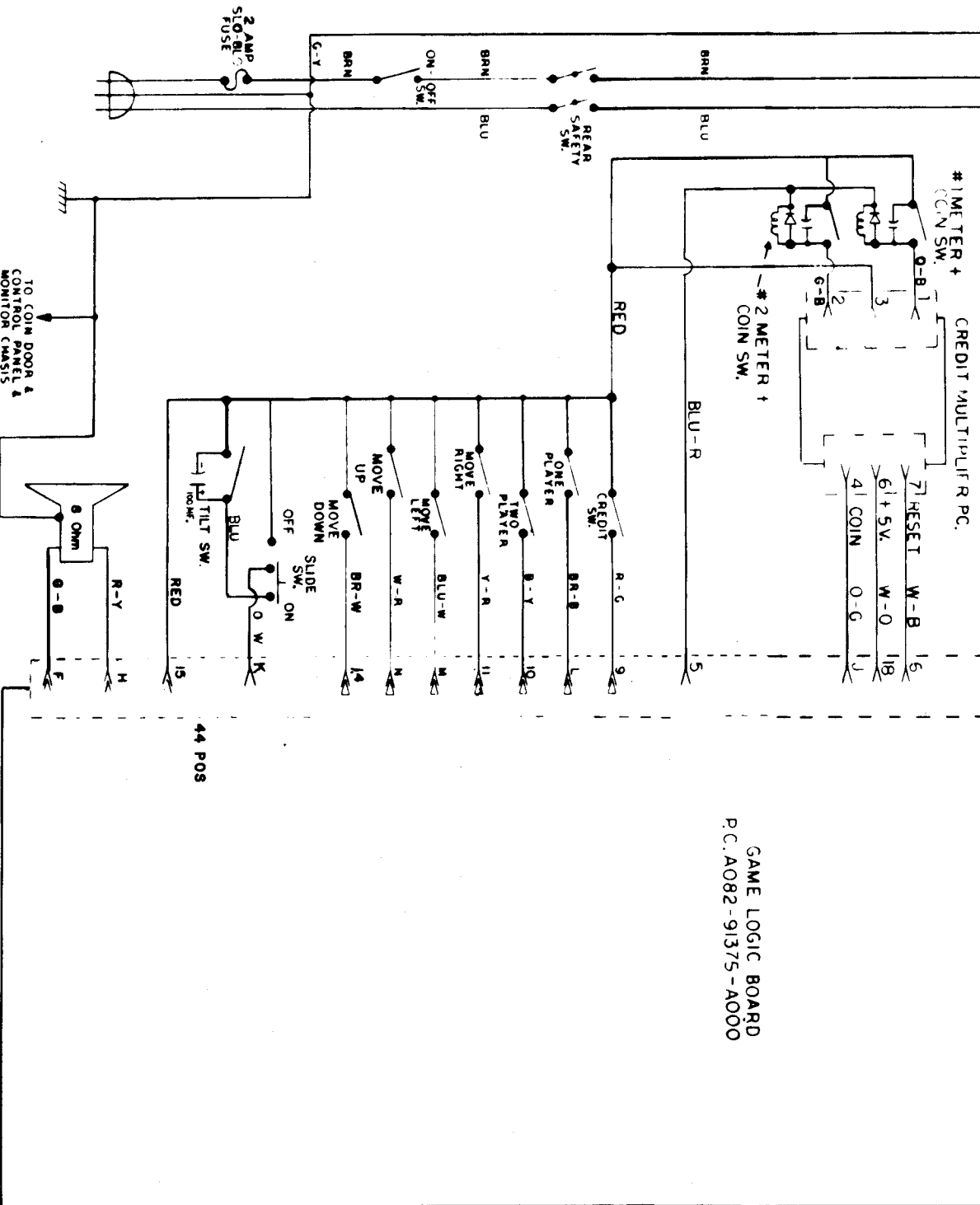

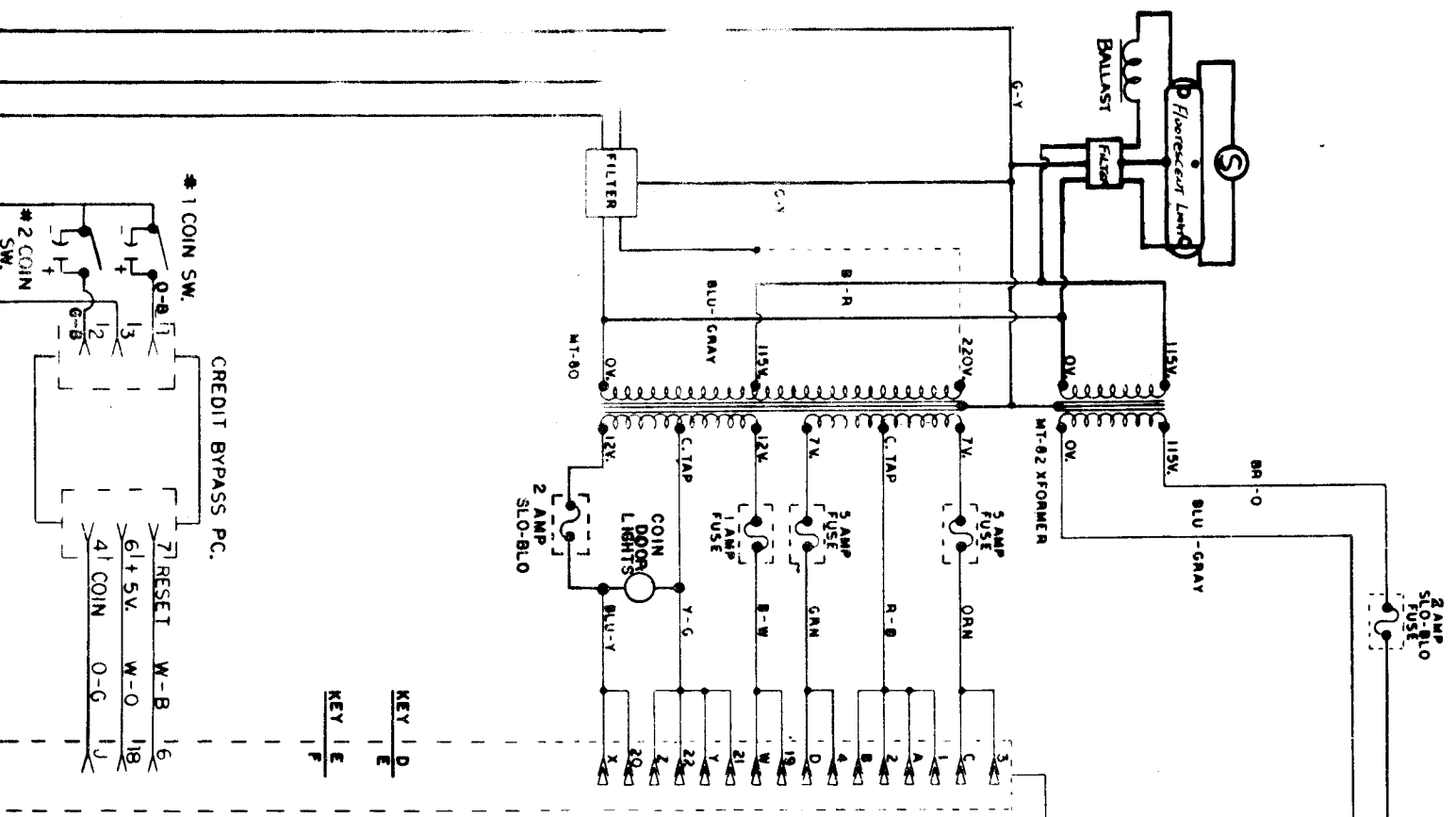

MS. PAC-MAN U.R.  
 ANDROMY MFG. CO.  
 10750 W. GRAND AVE.  
 FRANKLIN PARK ILL. 60131  
 WIRING SCHEMATIC PART NO. MOSI-00898-A003

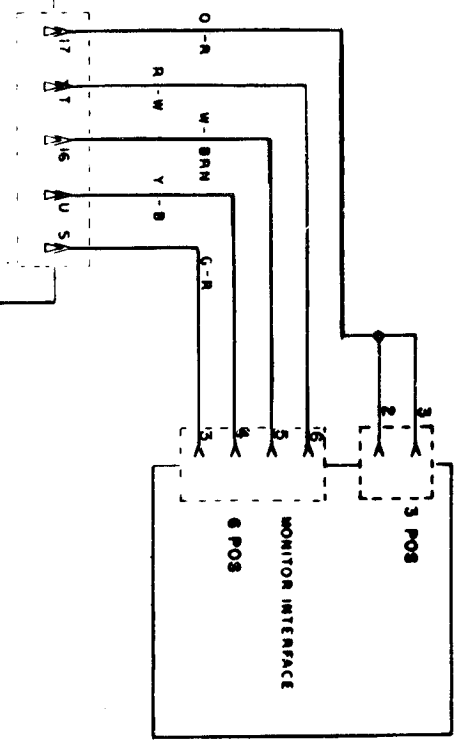
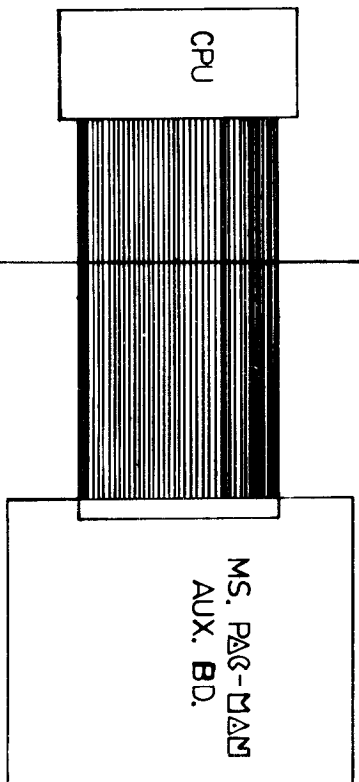

DATE	NAME
12/7/81	Y. Caporusso

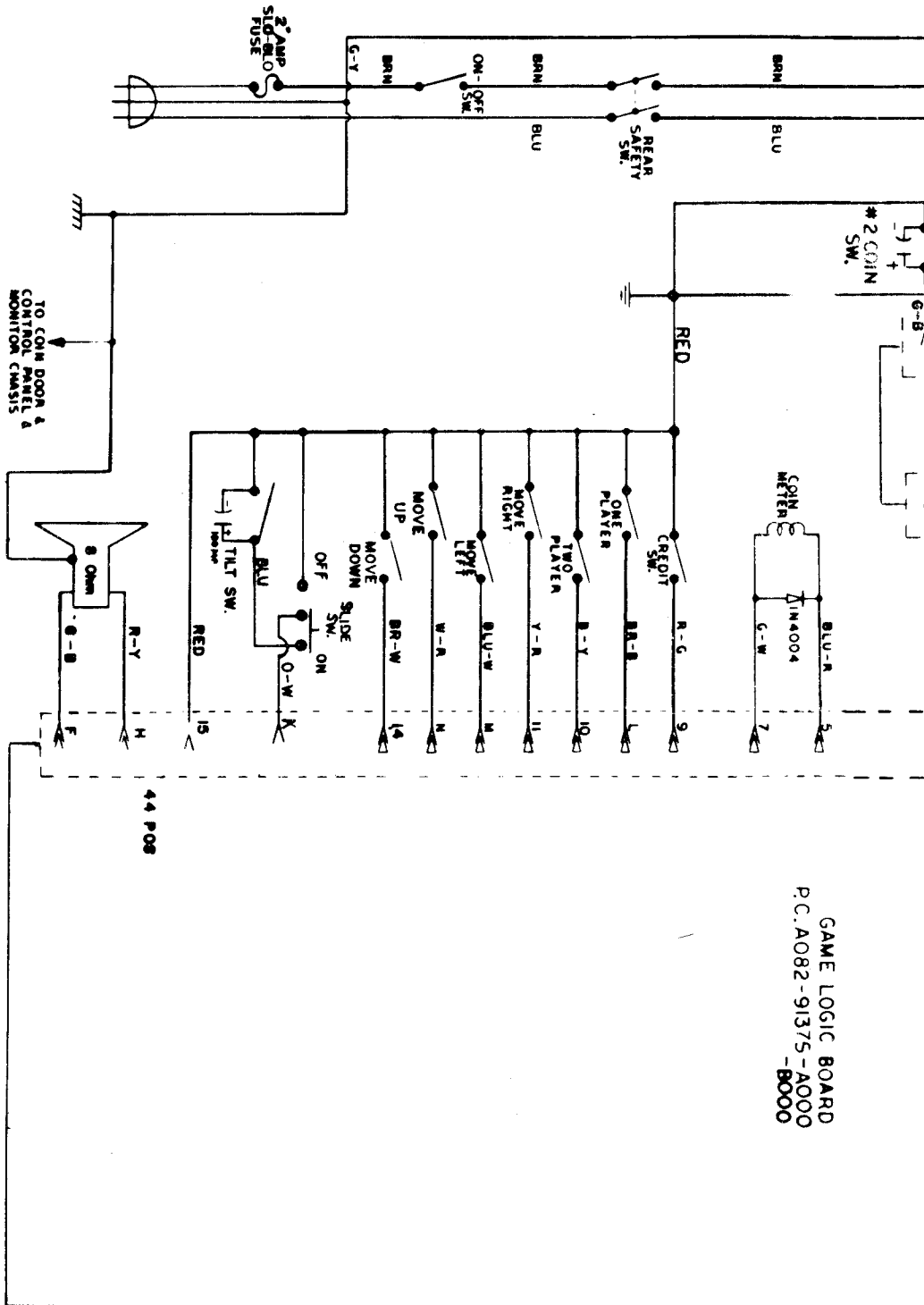

GAME LOGIC BOARD  
 P.C. A082-91375-A000  
 -B000

44 POS

REVISION	DATE
FLUORESCENT LIGHTS	12/7/80

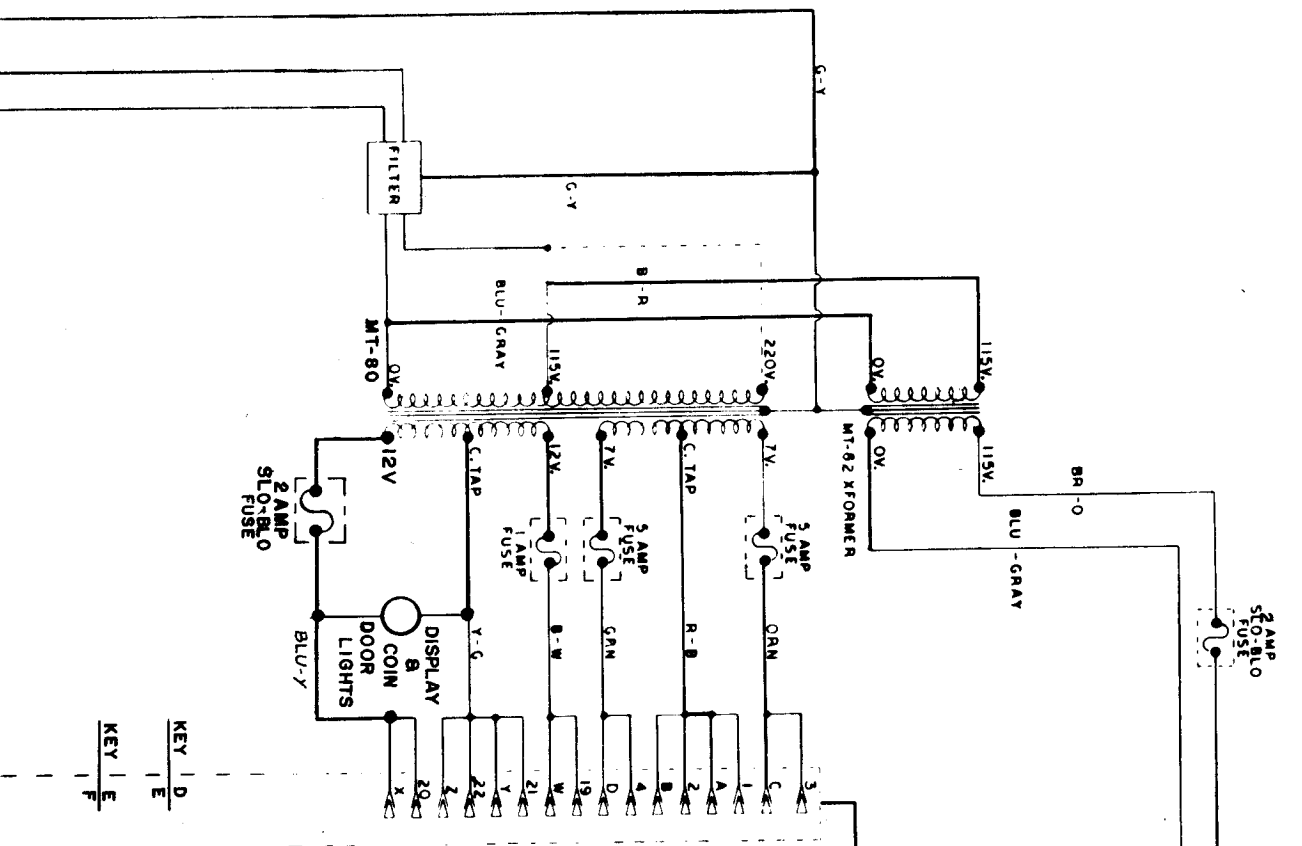

KEY D  
KEY E  
KEY F

MS PAC - MAN MINI  
ANDROMY MFG CO.  
10750 W. GRAND AVE.  
FRANKLIN PARK ILL. 60131  
WIRING SCHEMATIC PART NO. MOSI-00602-A004

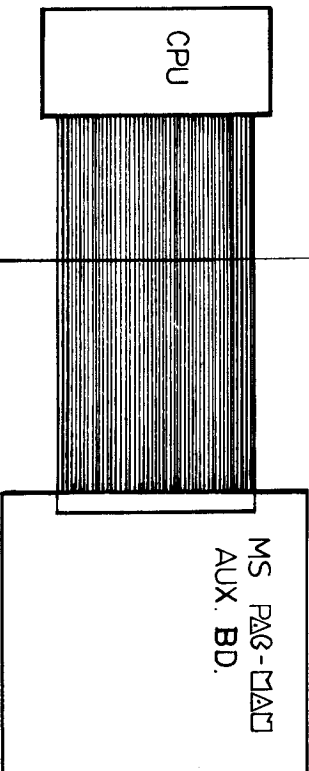
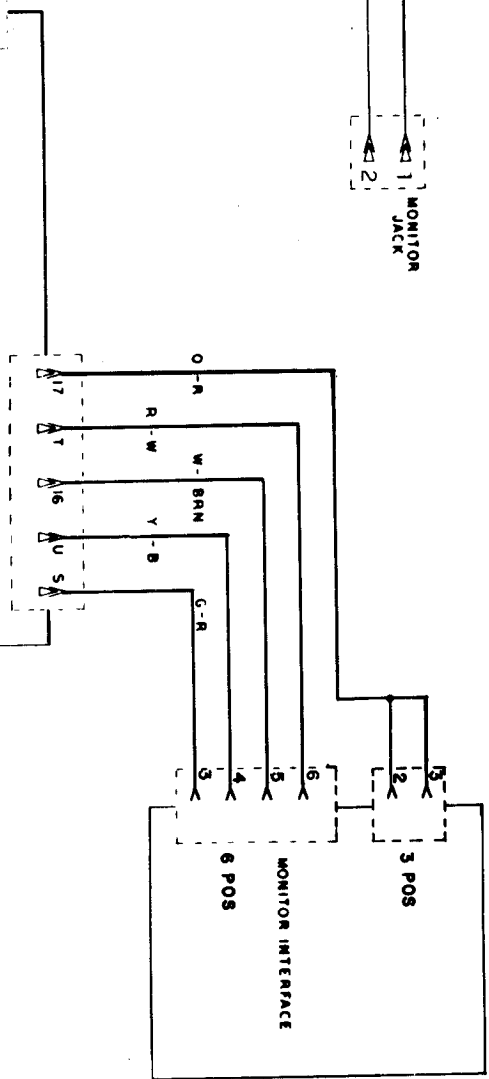

REVISION	DATE	NAME
MOUSE	12/14/81	V. Caporosso

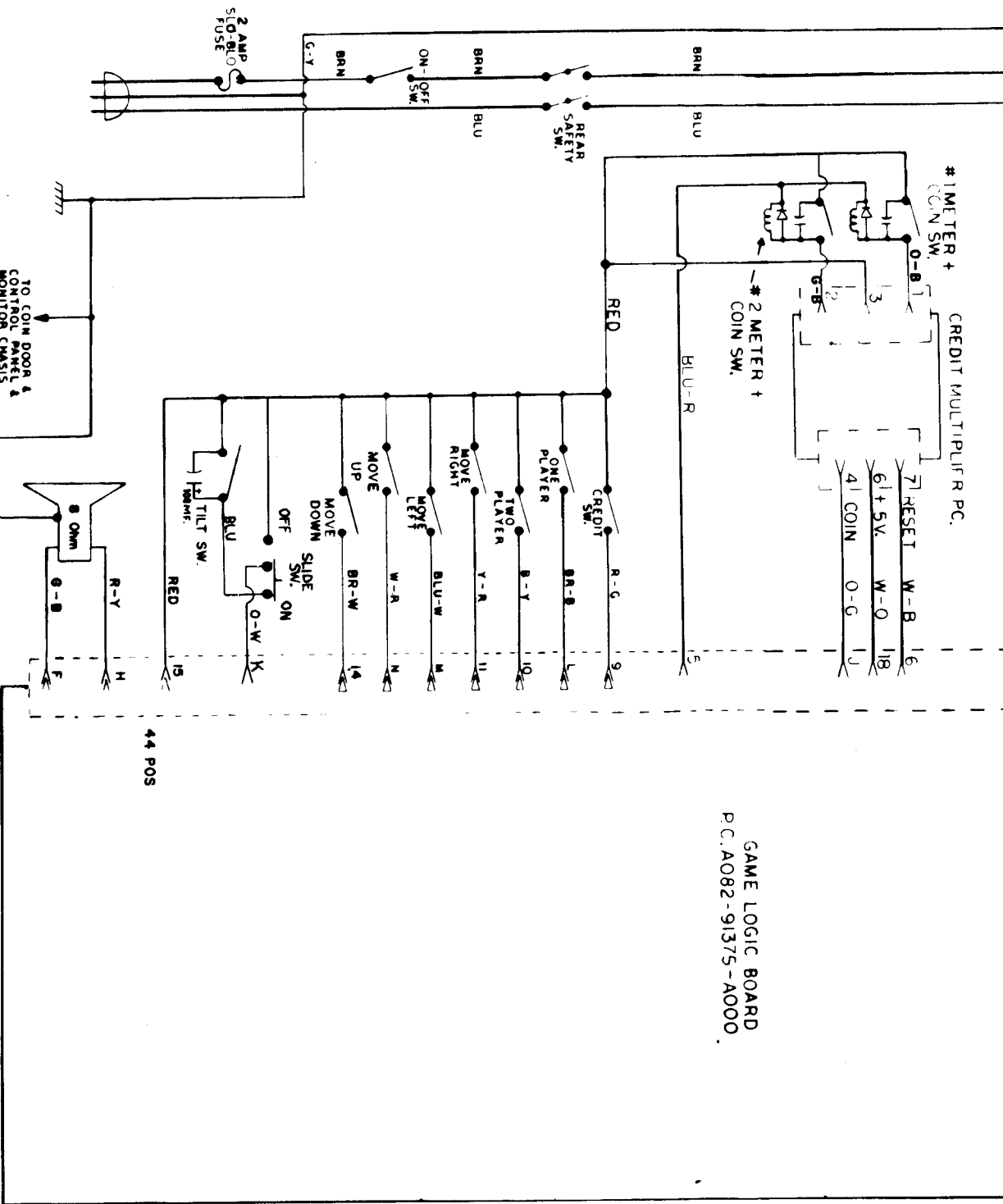

GAME LOGIC BOARD  
P.C. A082-91375-A000.

Revision	Date	Name
K00AE	12/14/61	V. Caporosso

44 POS

TO COIN DOOR &  
MONITOR CHASSIS

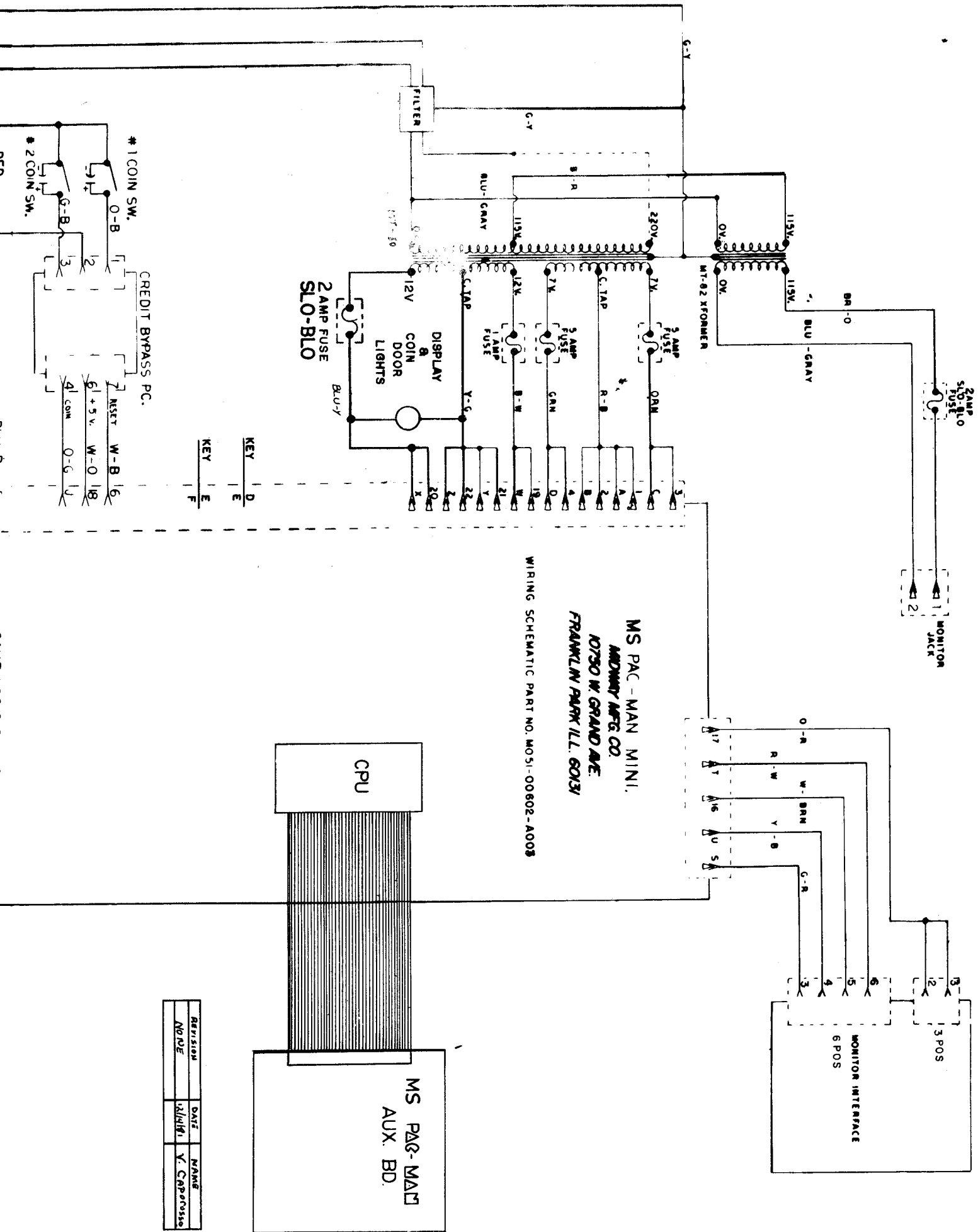



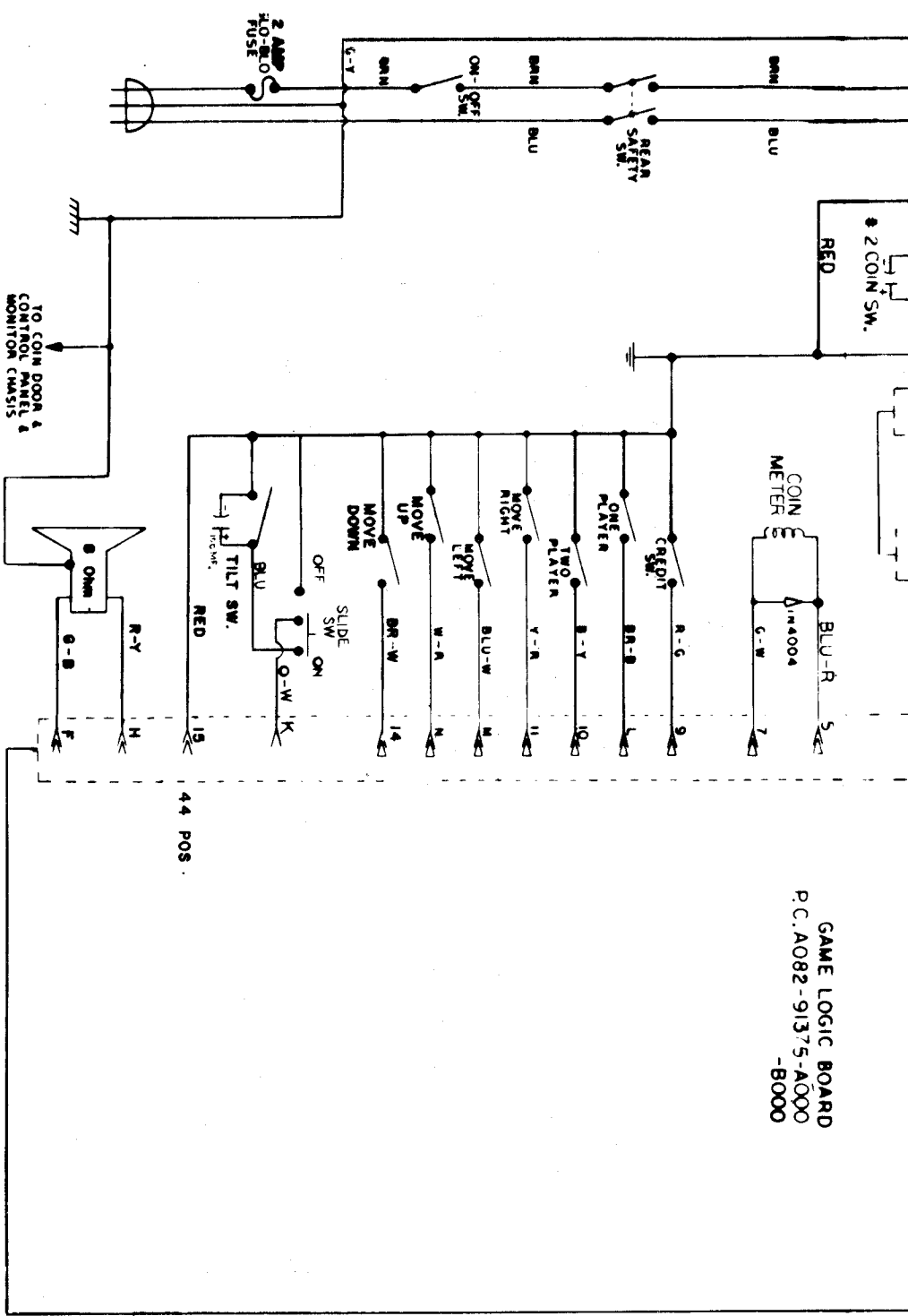

GAME LOGIC BOARD  
 P.C. A082-91375-A000  
 -B000

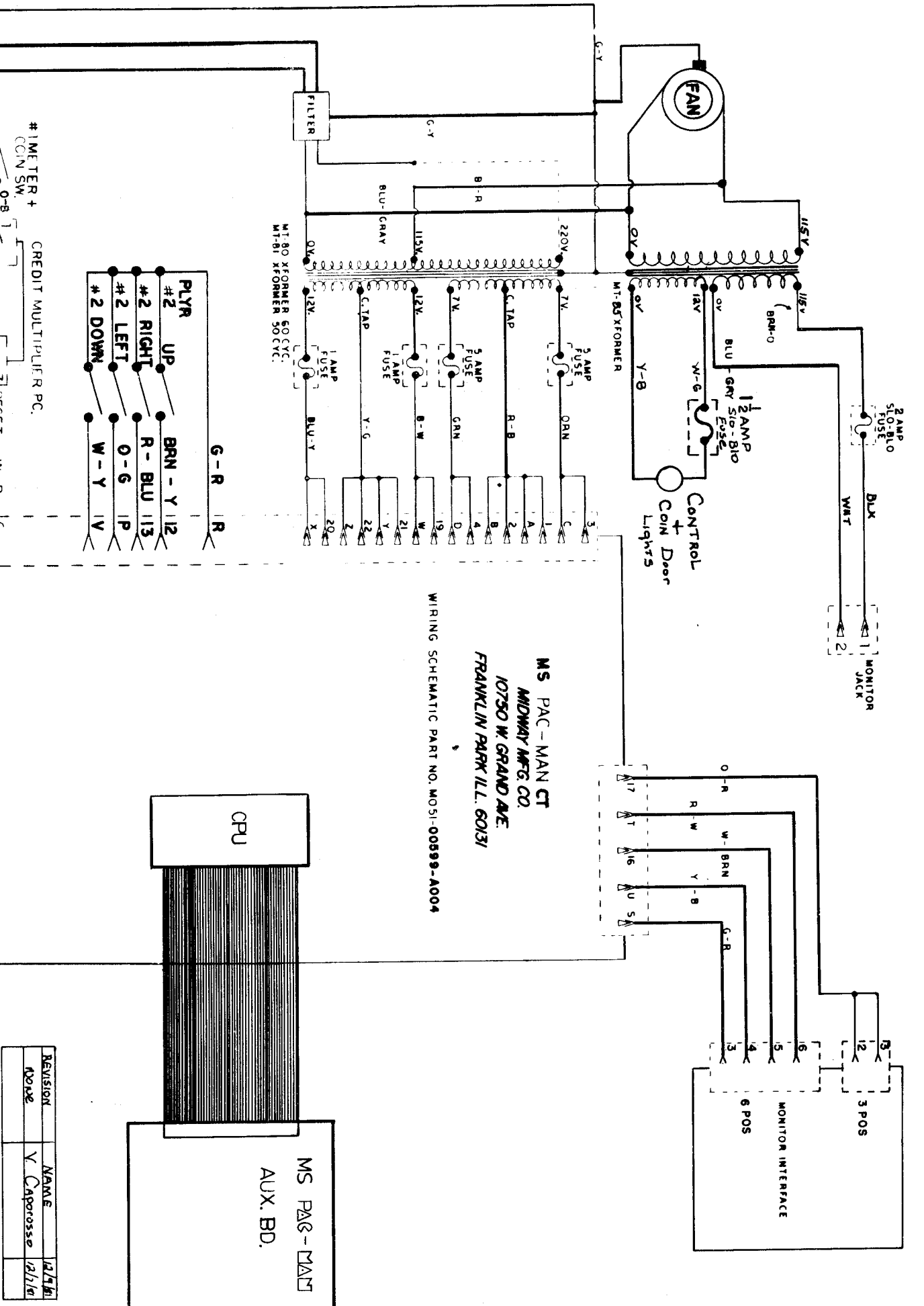

MS PAC-MAN CT  
 MIDWAY MFG. CO.  
 10750 W. GRAND AVE.  
 FRANKLIN PARK ILL. 60131

WIRING SCHEMATIC PART NO. MOSI-00599-A004

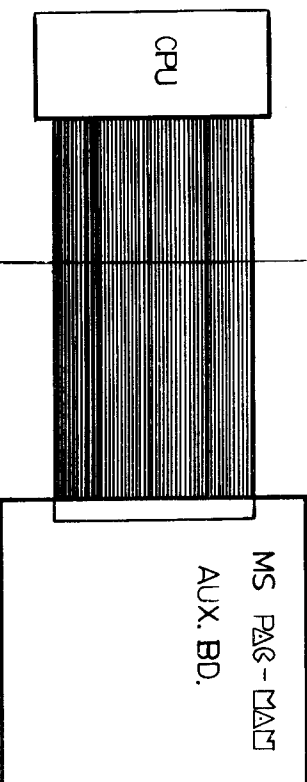

#1 METER +  
 CCIN SW.  
 CREDIT MULTIPLIER PC.  
 0-8

REVISION	NAME	DATE
1000	V Caporosso	12/1/81

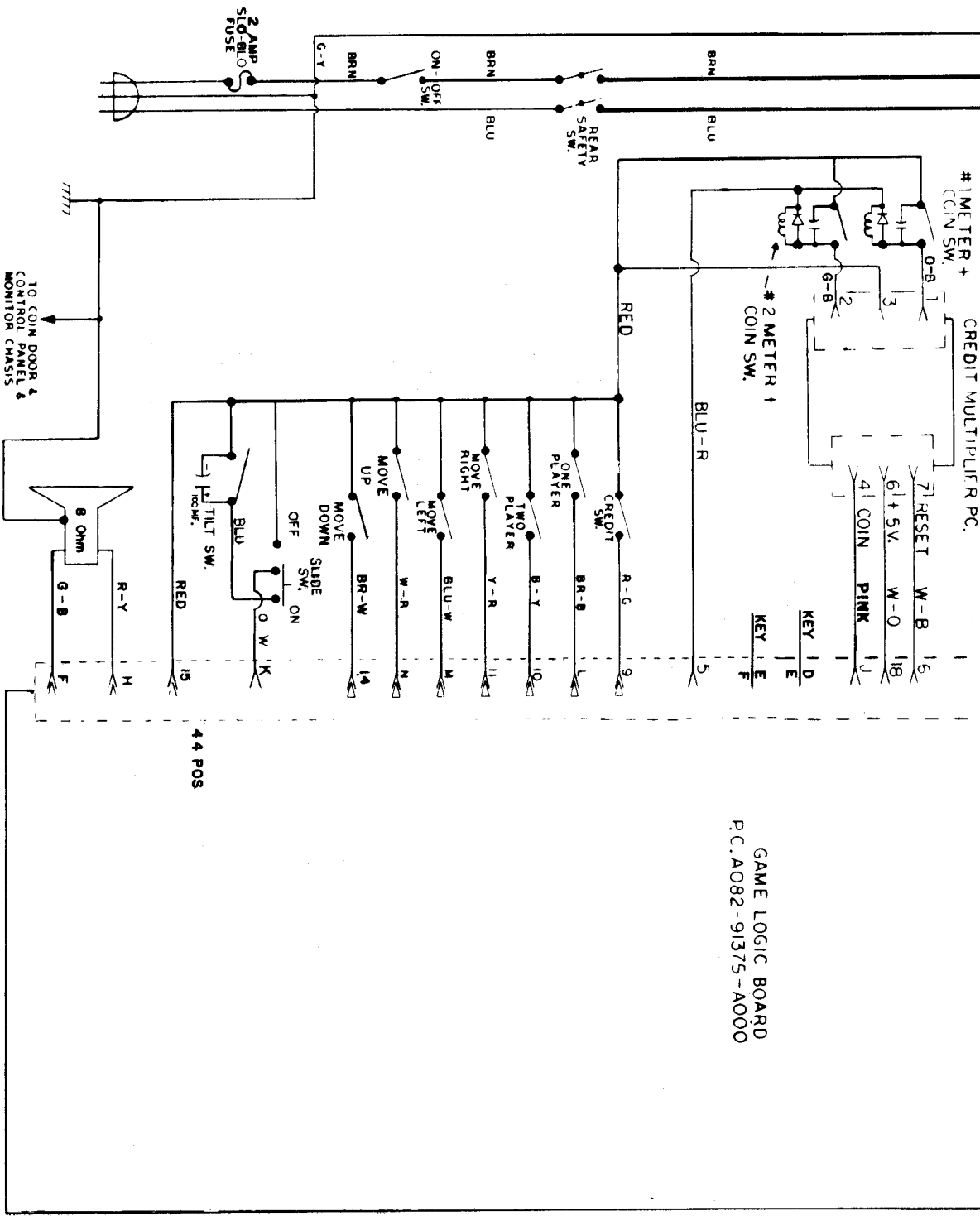

GAME LOGIC BOARD  
P.C. A082-91375-A000

DATE	V Caporosso	2/7/61
------	-------------	--------

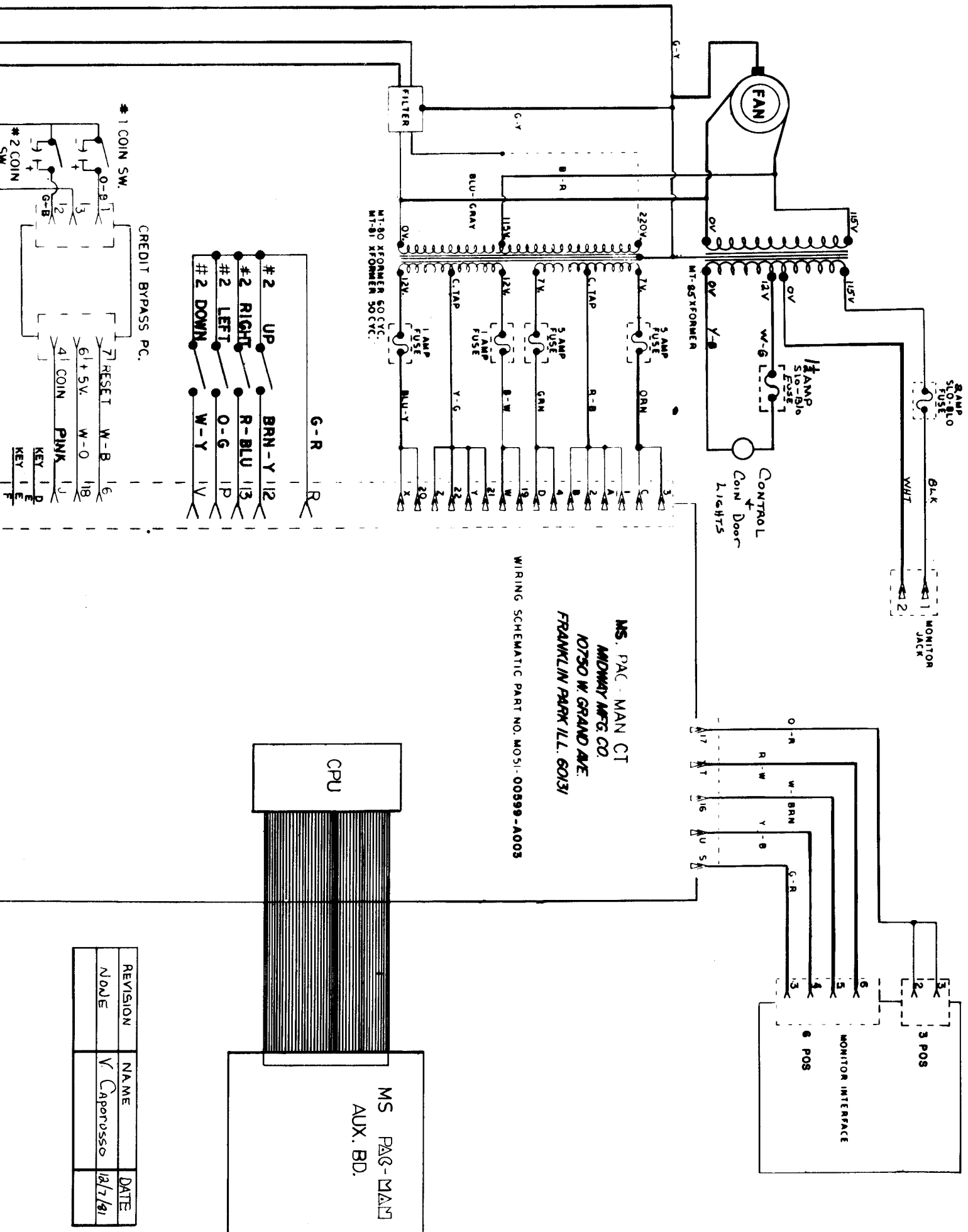

MS. PAC-MAN CT  
 MIDWAY MFG CO.  
 10750 W. GRAND AVE.  
 FRANKLIN PARK ILL. 60131

WIRING SCHEMATIC PART NO. MOSI-00599-A003

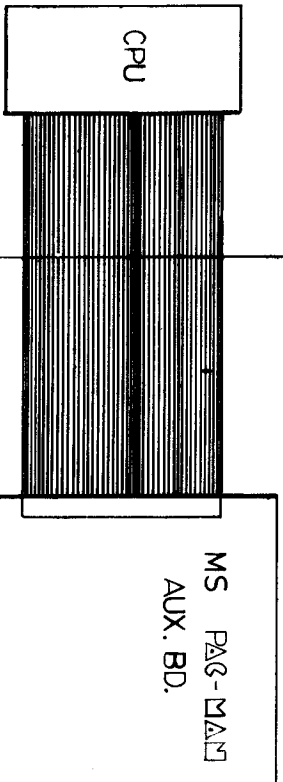

REVISION	NAME	DATE
None	V Caporosso	12/7/81

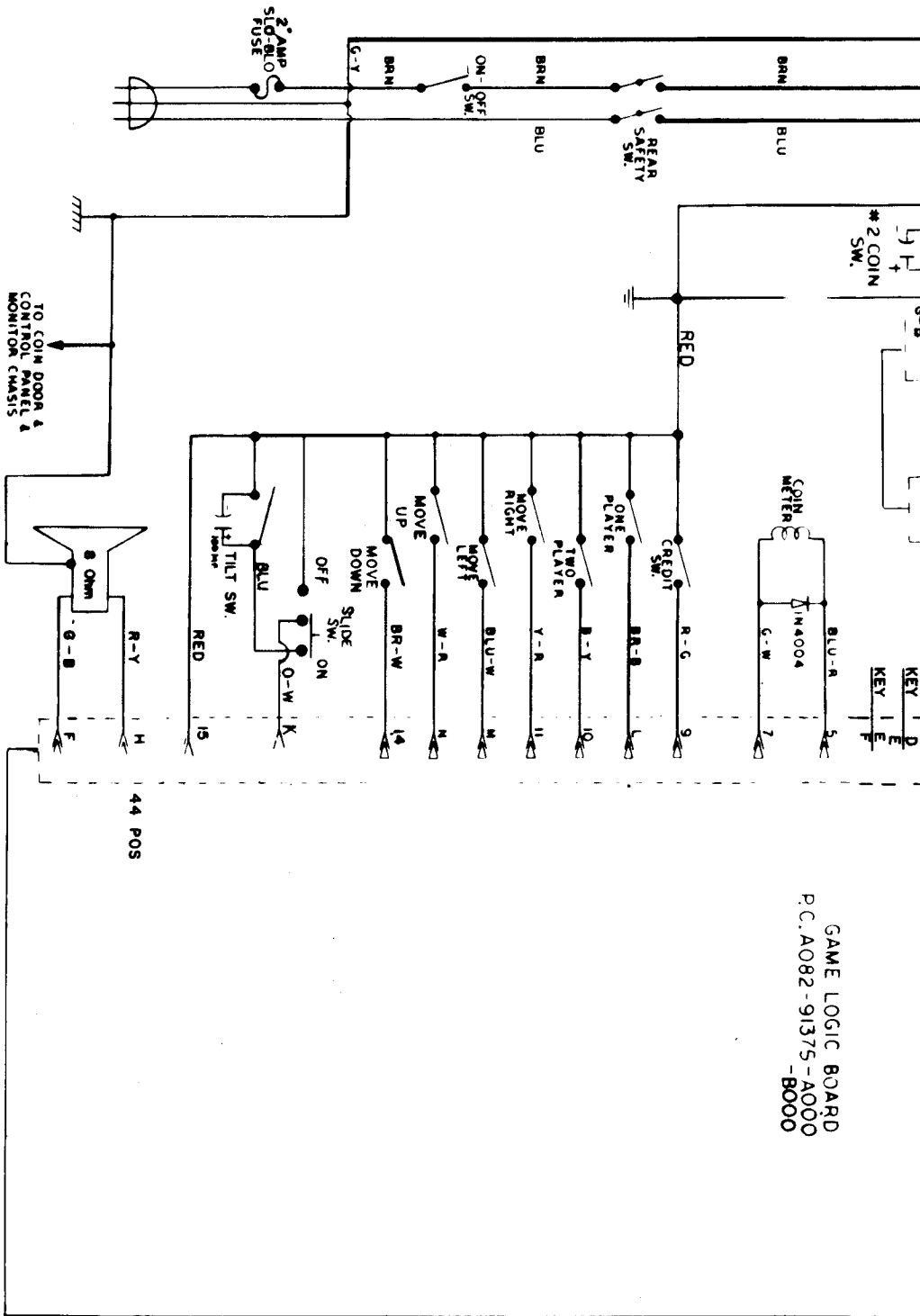

GAME LOGIC BOARD  
 P.C. A082-91375-A000  
 -B000

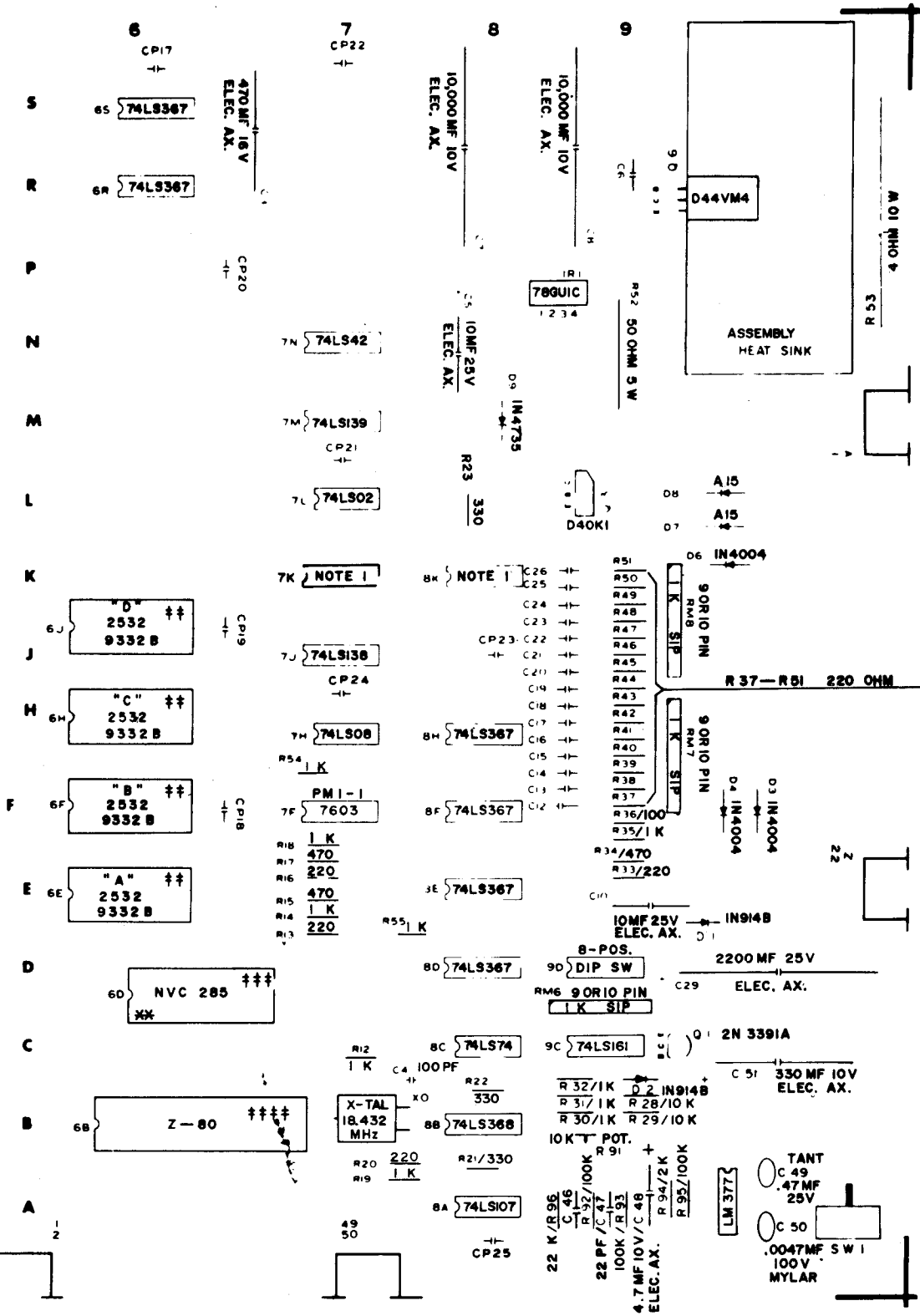

XX NOTE : THIS LOCATION CAN UTILIZE EITHER  
 (A) CUSTOM CHIP NVC285 OR (B) PLUG IN PC A082-91383-B000 Z-80 SYNC BUSS CONTROLLER (285)

XX NOTE : THIS LOCATION CAN UTILIZE EITHER  
 (A) CUSTOM CHIP NVC284 OR (B) PLUG IN PC A082-91384-B000 V-RAM ADDRESSER (284)

M051-00932-B026

DO NOT SCALE DWG		HEAT TREAT	SCALE	USED ON PAC-MAN "B"
DIM TOLERANCES UNLESS SPECIFIED		MAT'L	NO REQD   PER	
CONCENTRICITY FOR DIA	±0.01	FINISH		
RECTANGULAR	±0.01			
DIAMETER	±0.01			
HOLE DIA	±0.02 0.00	DATE	10/9/80	

ASSEMBLY DRAWING  
 PAC-MAN

MIDWAY MFG. CO.  
 FRANKLIN PK ILL

PART NO.  
 A082-91375-B000

REVISIONS

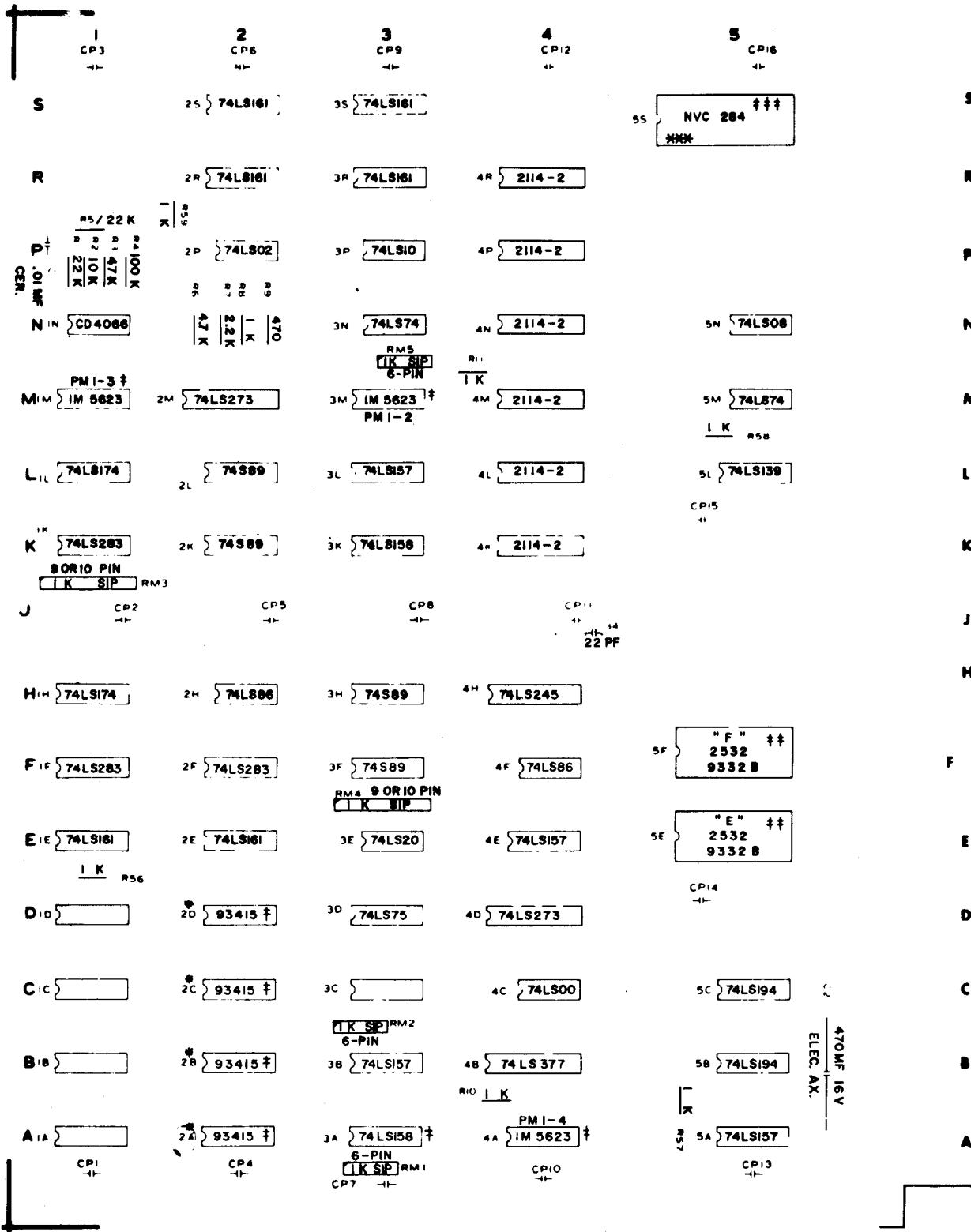

**\* RAM HEAT SINK ASSEMBLY**

NOTE 1: PLACE EITHER 74LS259 IN LOC. 8 K  
OR CD4099 IN LOC. 7 K

UNMARKED CAPS ARE .1MF CER. AX.  
RESISTOR UNIT = Ohm

- † - 16 PIN SOCKET ( 9 PER )
- †† - 24 PIN SOCKET ( 6 PER )
- ††† - 28 PIN SOCKET ( 2 PER )
- †††† - 40 PIN SOCKET ( 1 PER )

XX NOTE : T

XXX NOTE : T

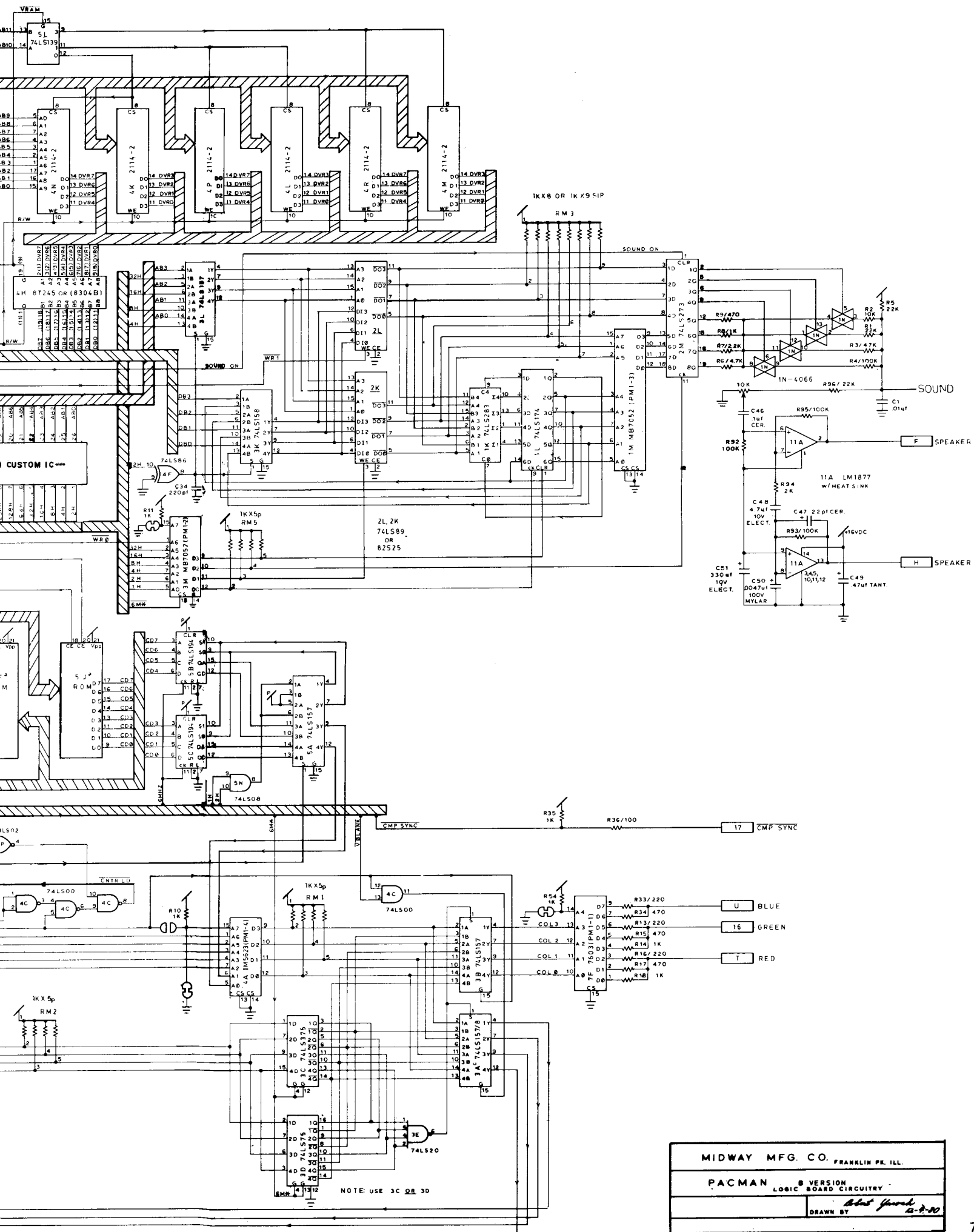

MIDWAY MFG. CO. FRANKLIN PK. ILL.

PACMAN B VERSION LOGIC BOARD CIRCUITRY

DRAWN BY *Blair Ford* 12-9-80



NOTE:  
 USE 2532 ROMS AT 6E, 6F, 6H, 6J  
 OR USE 2716 ROMS AT 6E-6F

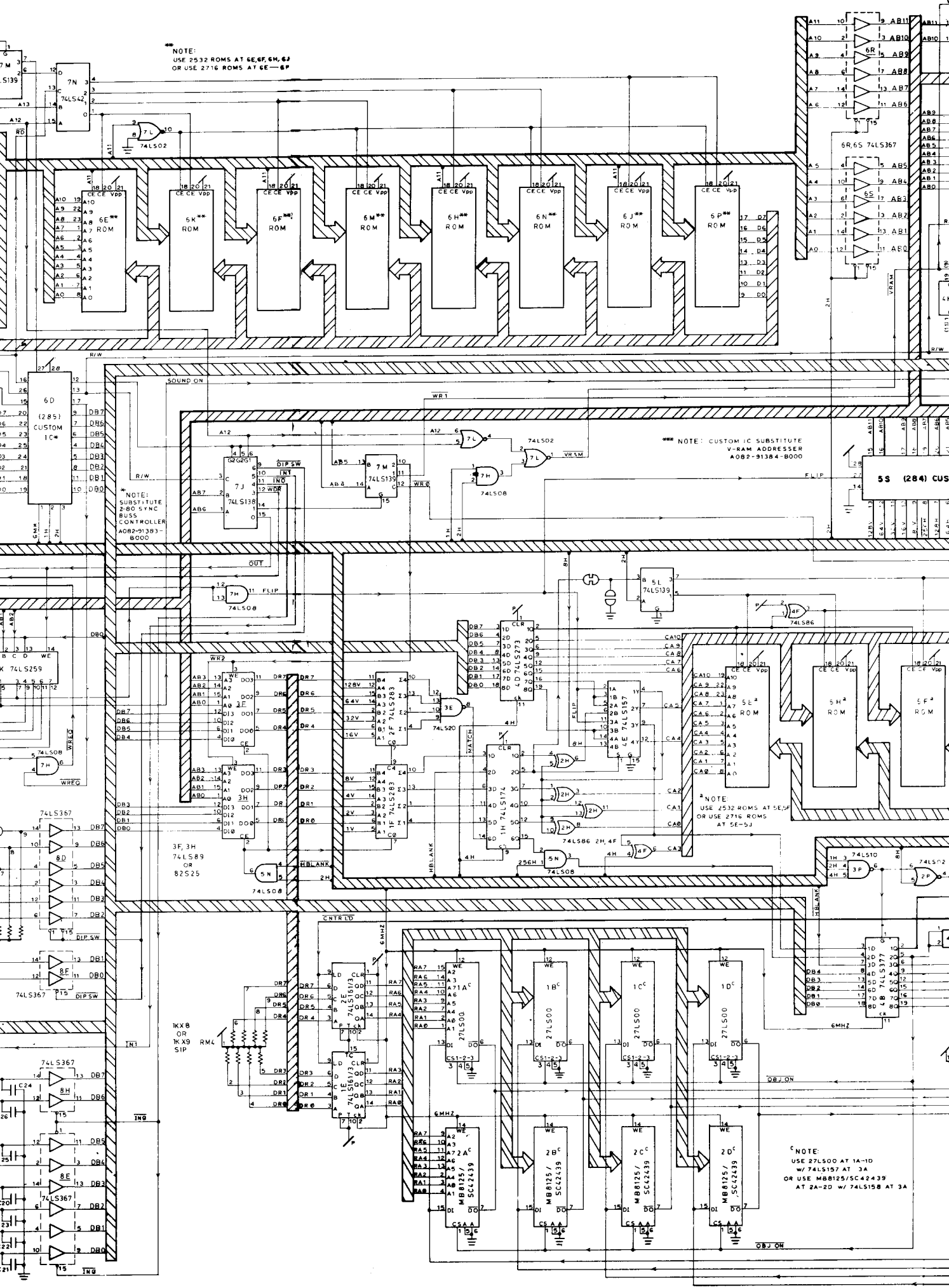

NOTE:  
 SUBSTITUTE  
 2-80 SYNC  
 BUSS  
 CONTROLLER  
 A082-91383-  
 B000

NOTE: CUSTOM IC SUBSTITUTE  
 V-RAM ADDRESSER  
 A082-91384-B000

NOTE  
 USE 2532 ROMS AT 5E, 5F  
 OR USE 2716 ROMS  
 AT 5E-5J

NOTE:  
 USE 27LS00 AT 1A-1D  
 W/ 74LS157 AT 3A  
 OR USE MB8125/SC42439  
 AT 2A-2D W/ 74LS158 AT 3A

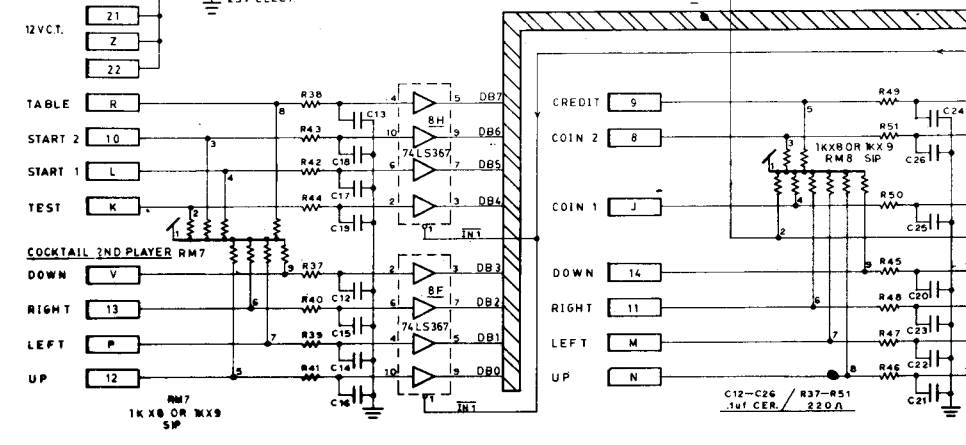
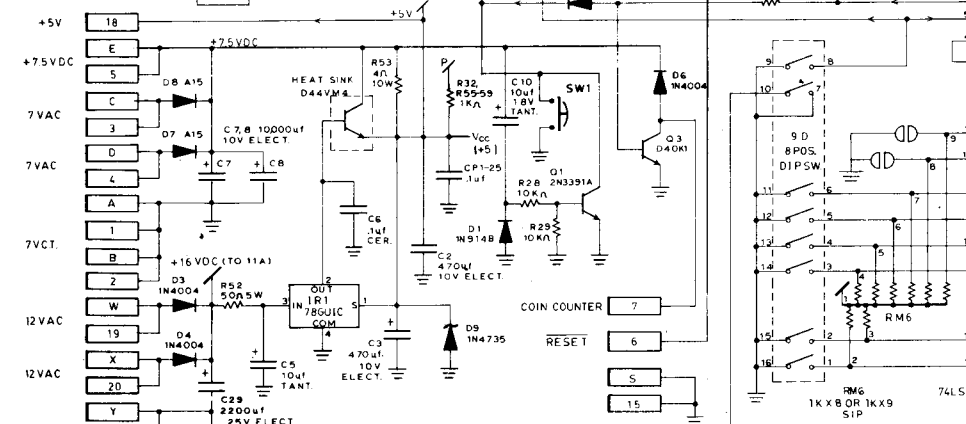
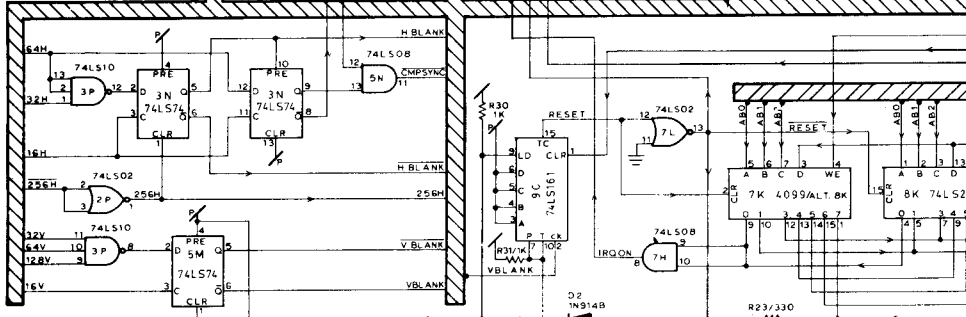
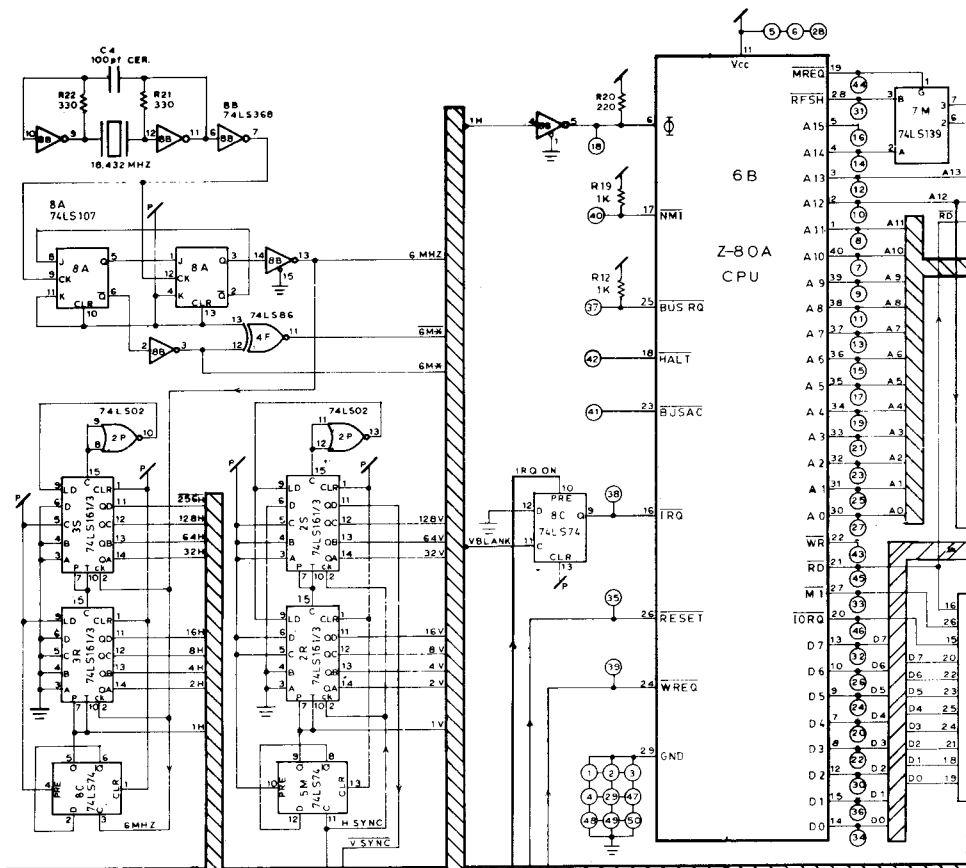

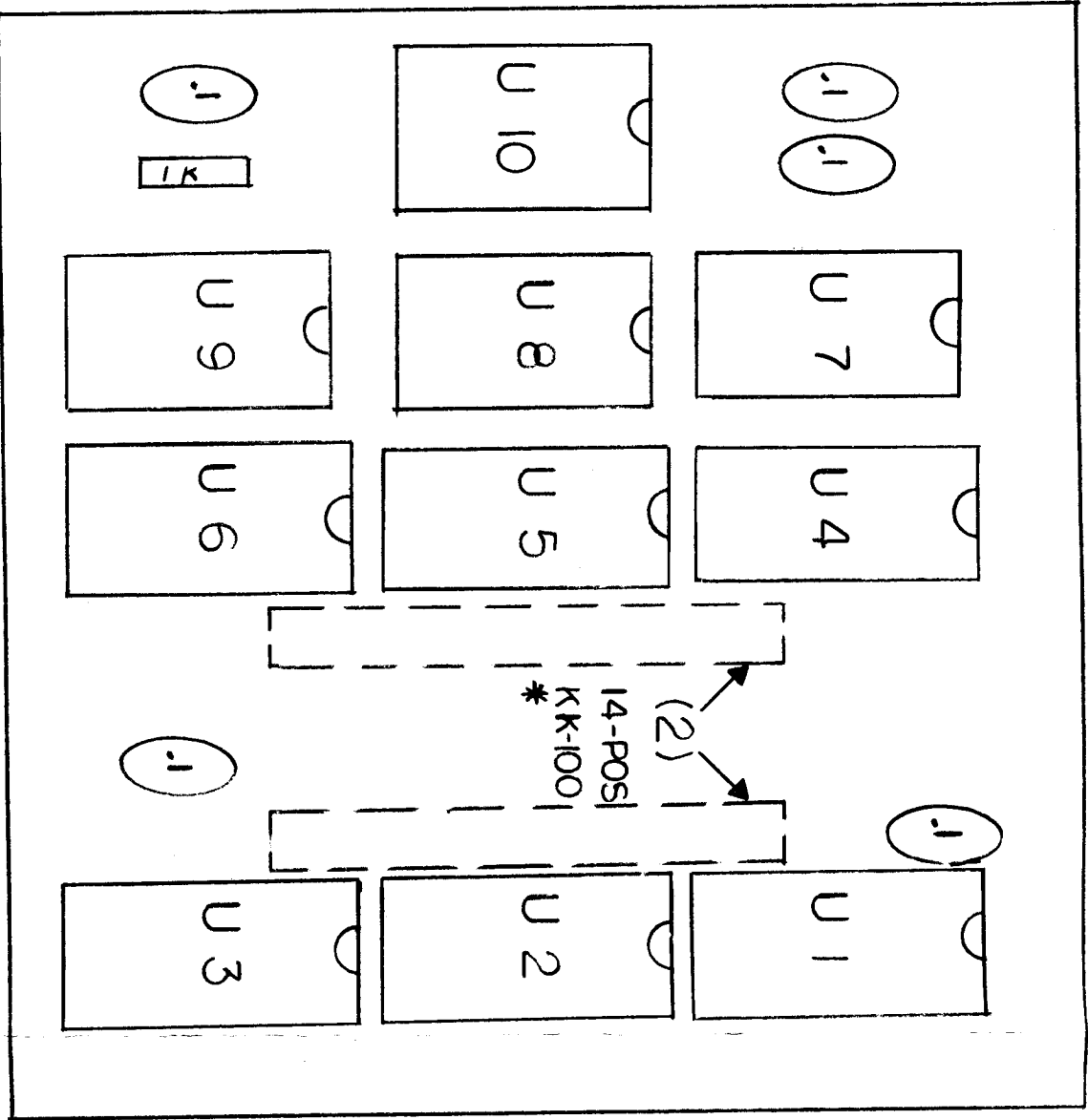

- U1, U2, U3, -74LS257
- U4, U5, U6, -74LS157
- U7, U8, U9, -74LS86
- U10 -74LS02
- .1 MF 50V - (5)
- AX CER
- 1K 1/4w - (1)
- (2) - 14-POS. KK-100
- \* MOUNTED ON SOLDER SIDE

MOSI-00932-B034

DO NOT SCALE DWG.

DIM. TOLERANCES UNLESS SPECIFIED

CONCENTRICITY T.I.R. .003  
 FRACTIONAL.....1/164  
 DECIMAL.....±.005  
 HOLE DIA.....+.002-.000

DRN. MM

CKD.

DATE 10-27-80

HEAT TREAT

MAT'L.

FINISH

SCALE

V-RAM ADDRESSER (284)  
 COMPONENT - LAY-OUT

USED ON PAC-MAN

NO. REQ'D I-PER.

**MIDWAY MFG. CO.**

FRANKLIN PK. ILL.

REVISIONS

PART NO.

A082-91384-B000

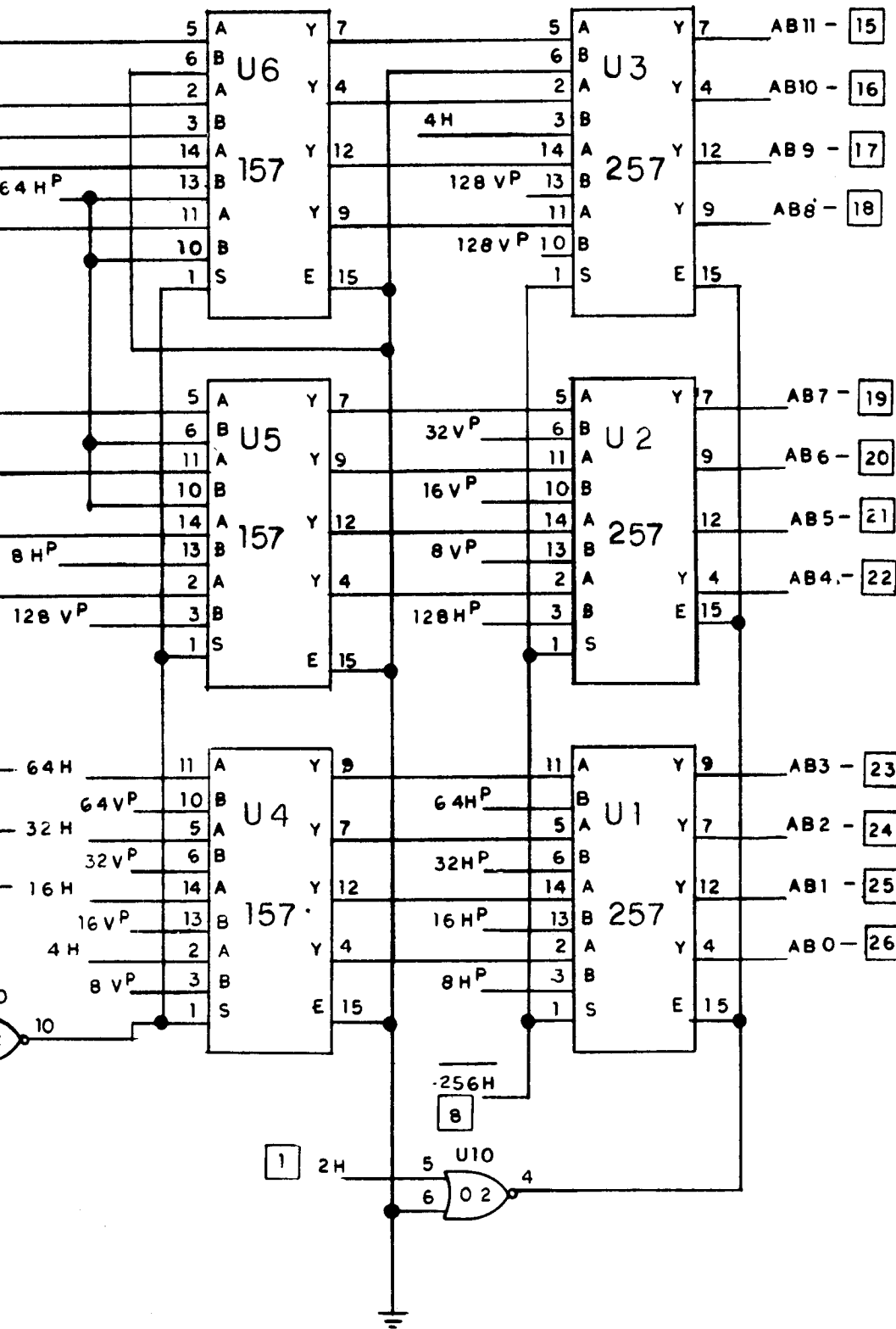

= 28 PIN CONNECTOR  
 P = PULL UP

<b>MIDWAY MFG. CO</b> FRANKLIN PARK ILL	
DRN M.M	CKD
DATE NOV 25 80	NO. REQ'D 1
USED ON PAC-MAN	
DESC. V RAM ADDRESSER (NVC-284)	
PARTNO. A082-91384-B000	

SCHEMATIC PART NO. M051 00932 B032

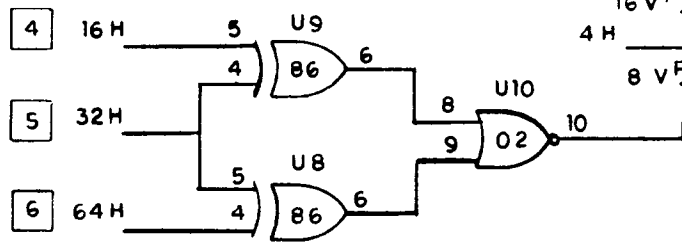
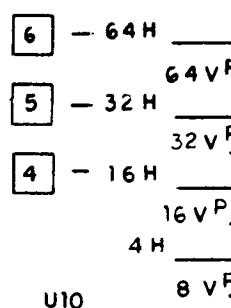
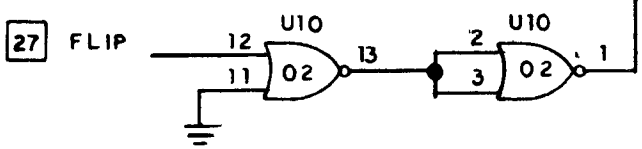
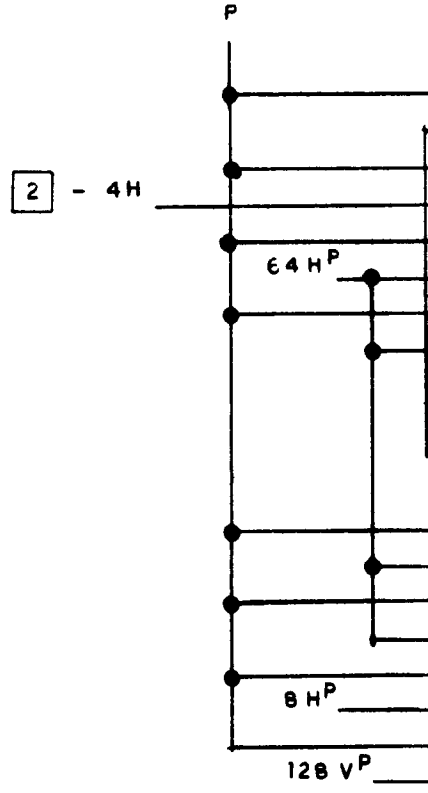
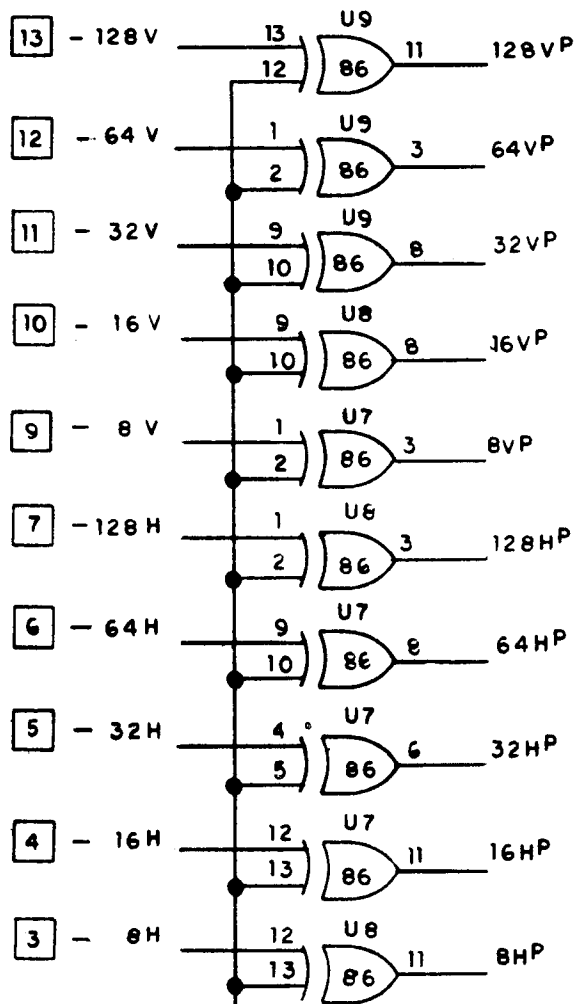
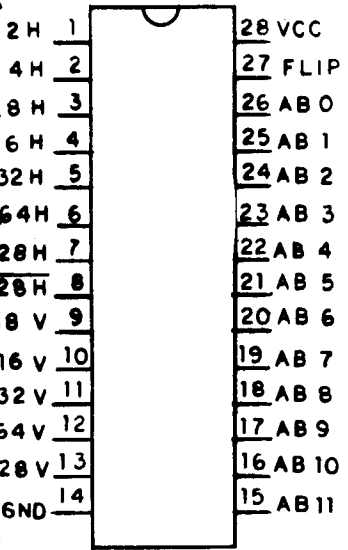

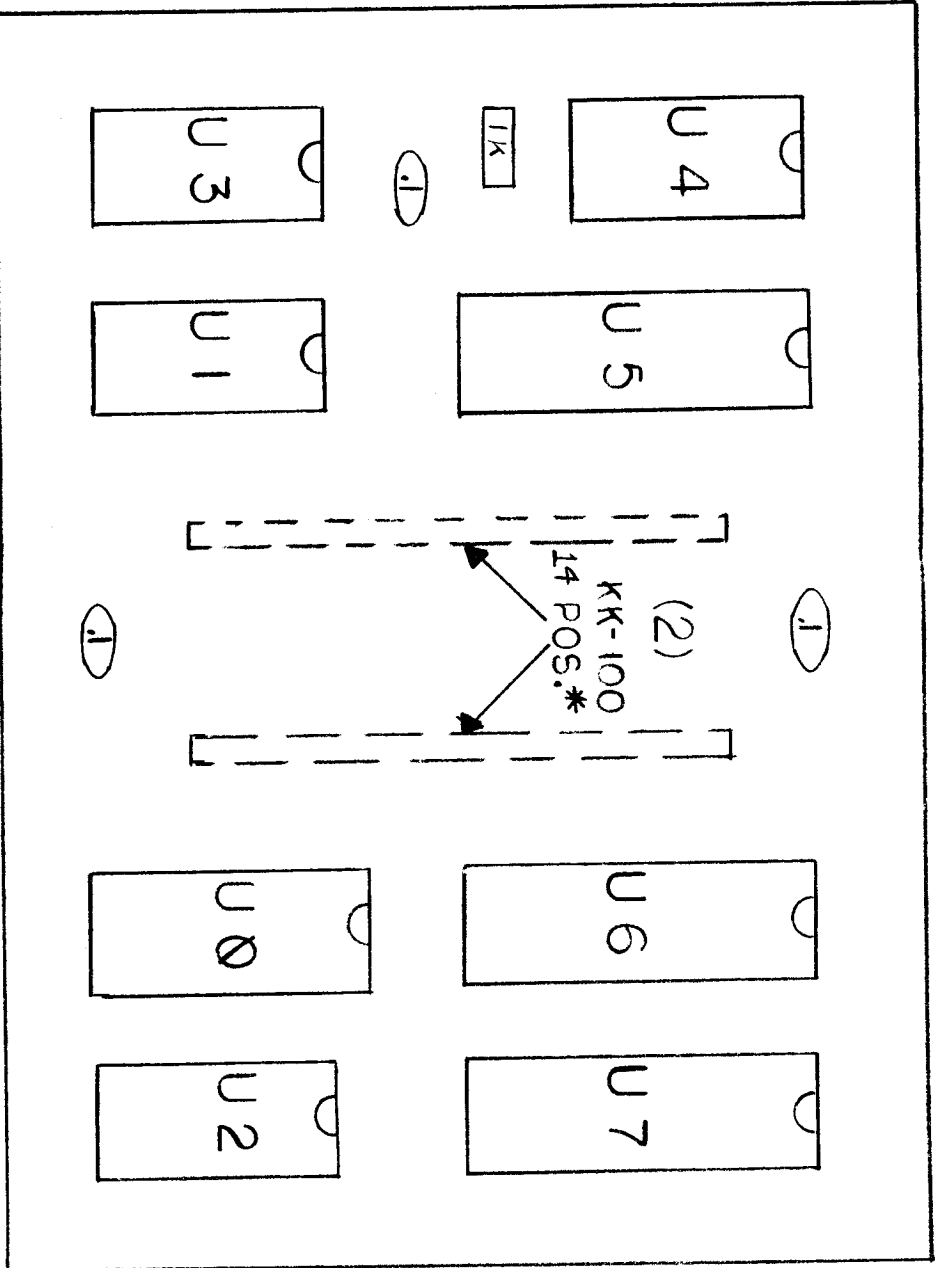

- U0-74LS139
- U1-74LS02
- U2-74LS74
- U3-74LS02
- U4-74LS74
- U5-74LS244
- U6-74LS374
- U7-74LS374
- (3)-.1MF 50V AX. CER.
- (1)-1K $\frac{1}{4}$ W RESIS.
- \* MOUNTED ON SOLDER SIDE

M051-00932-B031

REVISIONS	

USED ON PAC-MAN  
NO. REQ'D 1 - PER

**MIDWAY MFG. CO.**  
FRANKLIN PK. ILL.

**DO NOT SCALE DWG.**

**DIM. TOLERANCES UNLESS SPECIFIED**

CONCENTRICITY T.I.R. .003  
FRACTIONAL..... ± 1/64  
DECIMAL..... ± .005  
HOLE DIA..... + .002 - .000

DRN. M.M.  
CKD. P.S.  
DATE 10-23-80

HEAT TREAT  
MATERIAL  
FINISH

SCALE  
Z-80 SYNC BUSS CONTROLLER(285)  
COMPONENT LAYOUT

PART NO.  
A062-91383-8000

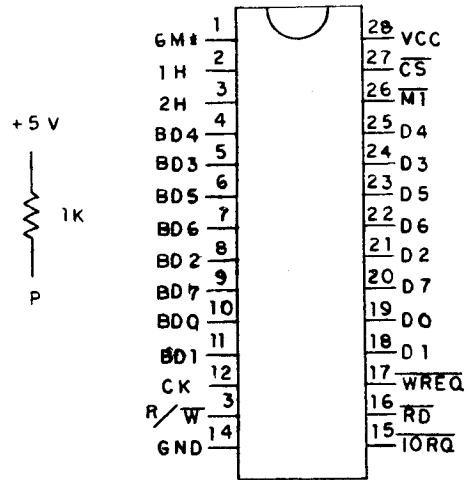
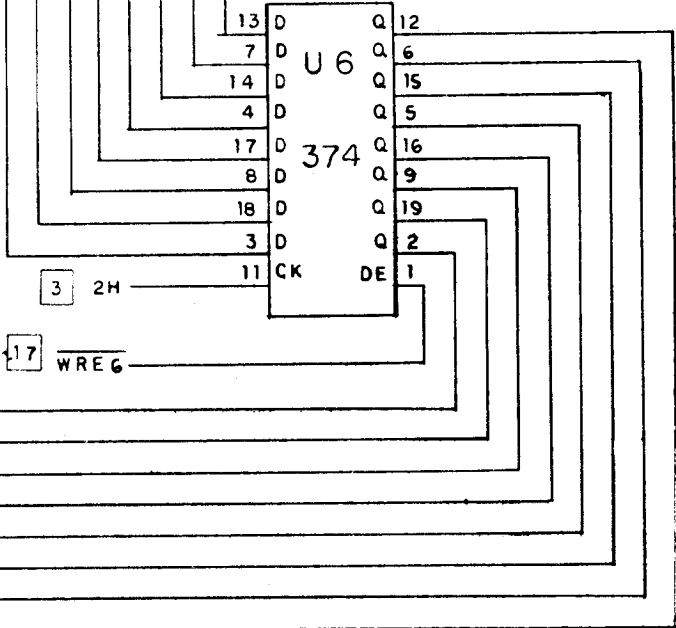
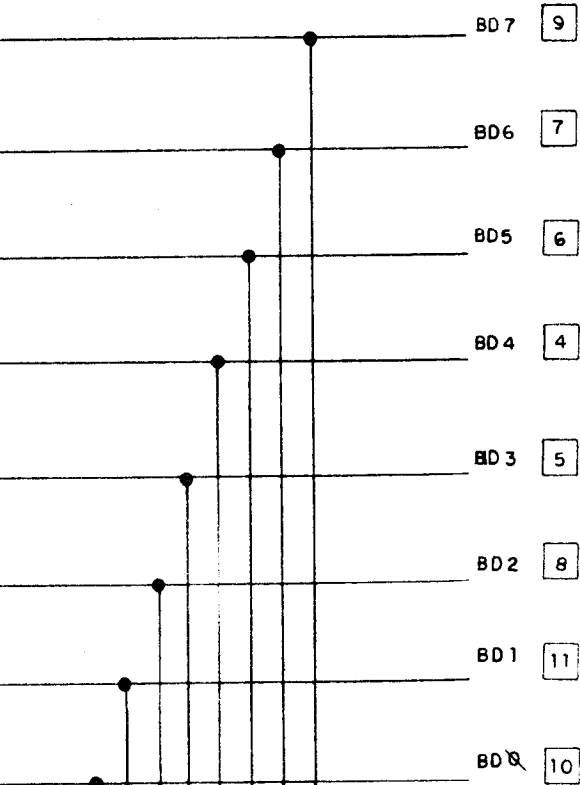
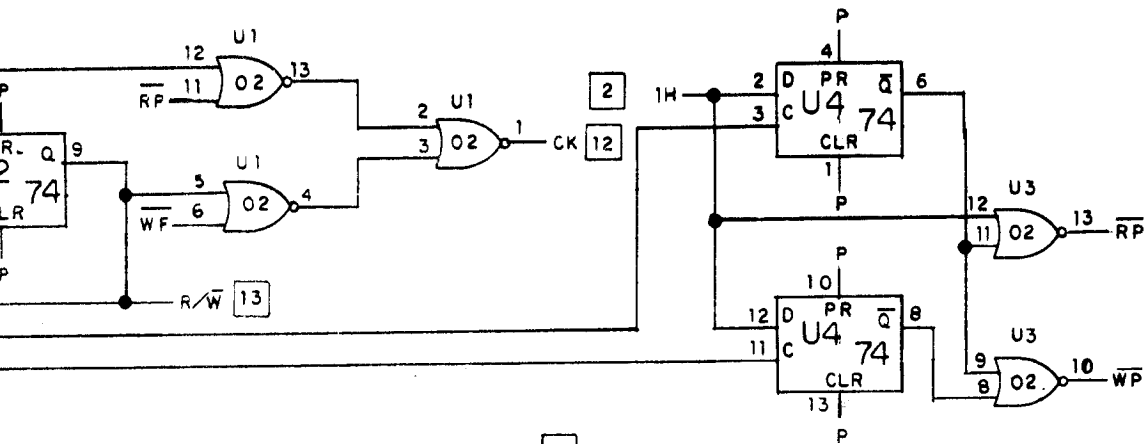

NOTES:

= 28 PIN CONNECTOR

P = PULL UP

MIDWAY MFG, CO.  
FRANKLIN PARK ILL

DRN. M.M	CKD.
DATE. NOV-21-80	NO. REQ'D 1
USED ON.	
DESC. Z 80 SYNC BUS CONTROLLER (285)	
PART NO. A082-91383-B000	

SCHEMATIC PART NO. M051-00932-B030

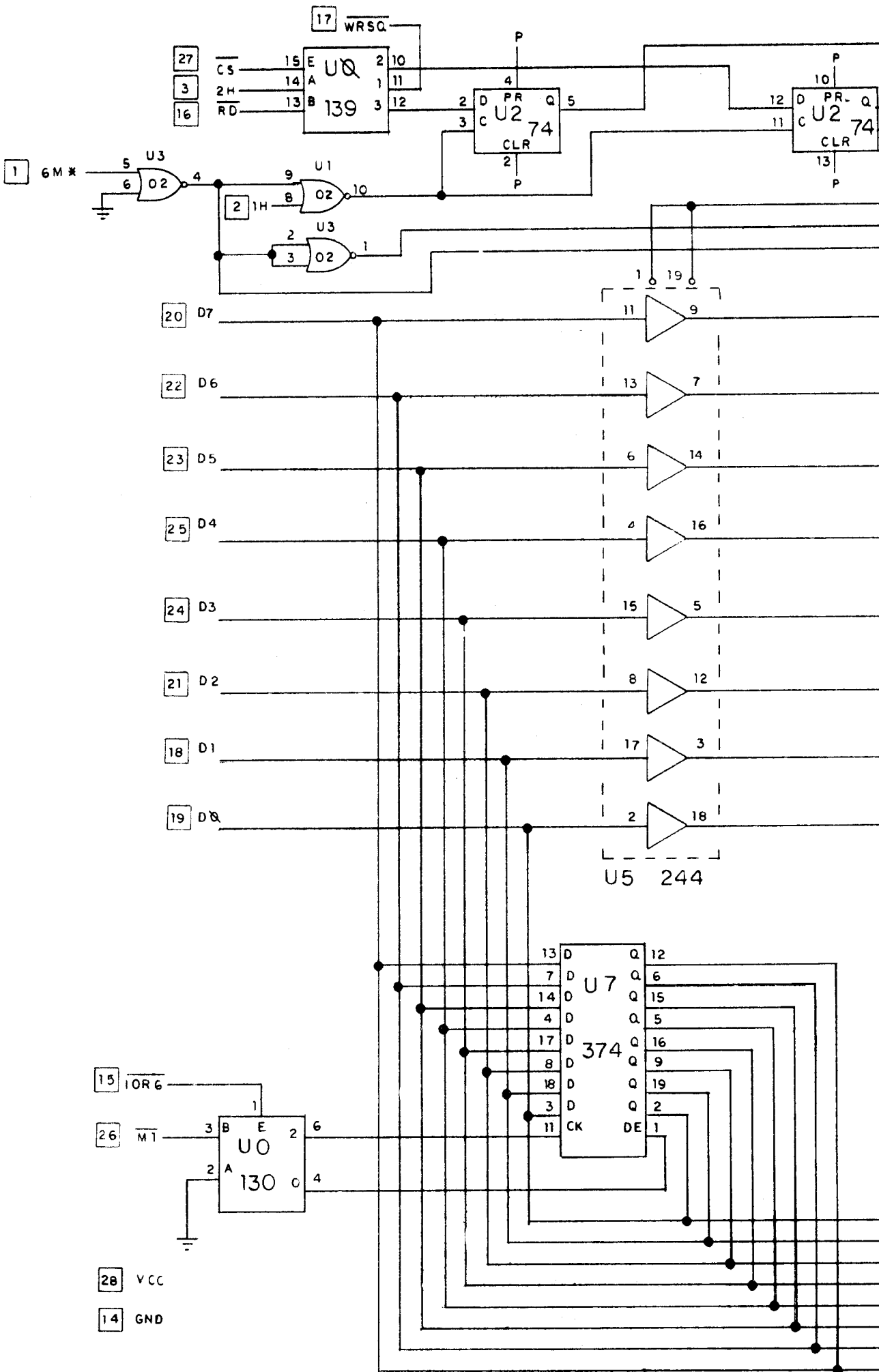



### CROSS REFERENCE LIST

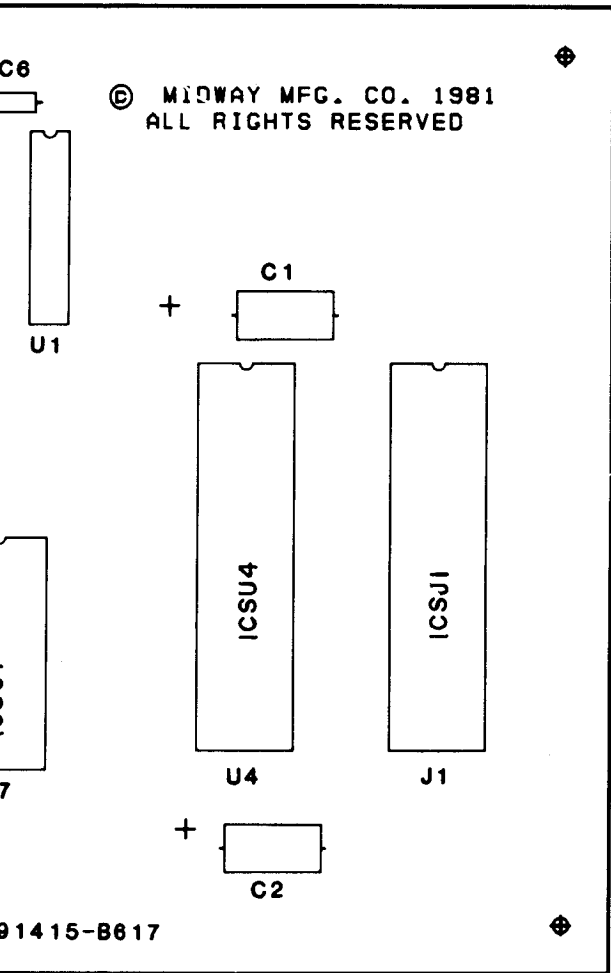

<u>DESCRIPTION</u>	<u>QUAN.</u>	<u>DESIGNATION</u>	<u>PART NO.</u>
.1MF AX. CER. CAP	4	C3-C6	0508-00800-0900
10MF AX. ELEC.	2	C1, C2	0508-00800-1100
CG820	1	U0	0066-014CX-XXQX
CG821	1	U1	0066-015CX-XXQX
CG822	1	U2	0066-016CX-XXQX
CG823	1	U3	0066-017CX-XXQX
Z-80A	1	U4	0932-00807-0000
EPROM 2532	1	U6	0595-00803-0200
" "	1	U7	0595-00803-0300
" 2716	1	U5	0595-00803-0100
20 PIN IC SOCKET	4	ICSU0-ICSU3	0508-00804-0100
24 PIN " "	3	ICSU5-ICSU7	0508-00804-0500
40 PIN " "	2	ICSU4, ICSJ1	0508-00804-1800
CABLE ASS'Y 40-PIN	1	J1	0595-00804-0200
MS. PAC-MAN AUX. P.C. BOARD	1		A080-91415-B617

ALL RIGHTS RESERVED & PROPERTY OF MIDWAY MFG. CO.

**MIDWAY MFG. CO.**  
 BLOOMINGTON, ILL. 60131 A BALLY CO.

ASSEMBLY DRAWING  
 PAC-MAN AUX P.C.  
 91415-8617

<b>REVISIONS</b>	
PART NO.	
<b>MO51-00617-B001</b>	

**DESIGNATION LIST**

<u>DESIGNATION</u>	<u>DESCRIPTION</u>
C1,C2	10MF ELEC. CAP.
C3-C6	.1MF CER.CAP
ICU0	CG820
" U1	CG821
" U2	CG822
" U3	CG823
" U4	Z-80A
" U5	EPROM 2716
" U6,U7	EPROM 2532
ICSU0-ICSU3	20 PIN IC SOCKET
" U4	40 PIN " "
" U5-ICSU7	24 PIN " "
" J1	40PIN " "
J1	CABLE ASS'Y. 40-PIN
PCB	MS.PAC-MAN AUX. P.C. BOARD

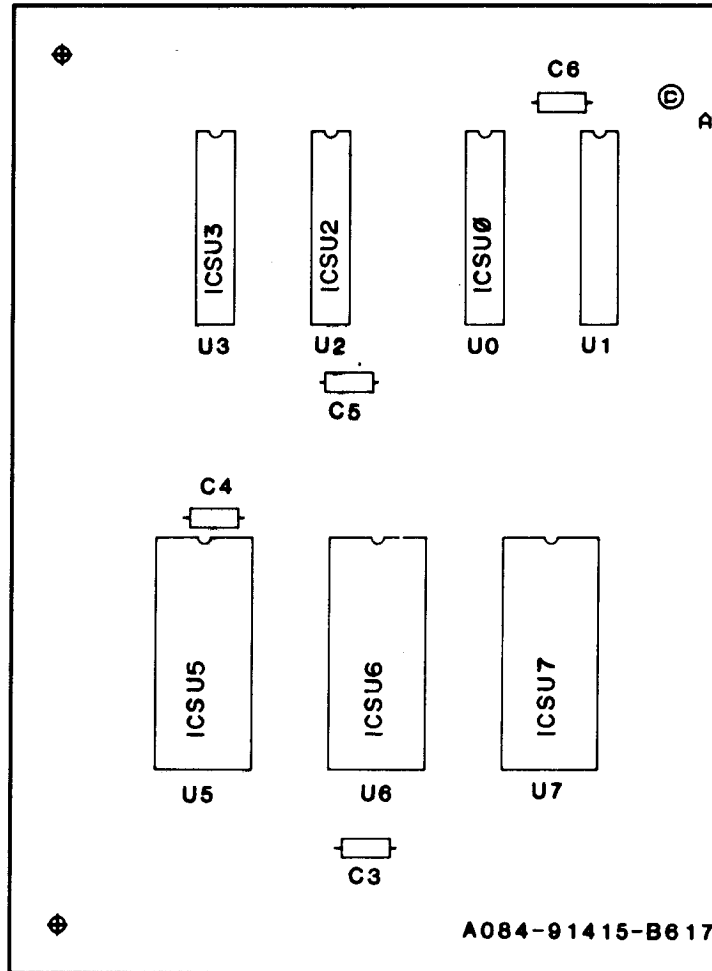

PROJECT ENG : J. SZERSZEN

THIS DWG IS CONFIDENTIAL & PROPERTY

<p><b>DIM. TOLERANCES</b>          UNLESS OTHERWISE SPEC          CONCENTRICITY T. R. .002          FRACTIONAL ± 1/64          DECIMAL ± .005          HOLE DIA + .002-- .000          ANGLE ± 1/2°          DO NOT SCALE DWG</p>	<p>FIRST USED ON: MS. PAC-MAN</p>			 <p><b>MIDWAY</b> FRANKLIN PK., IL.</p>
	<p>DATE <i>M. M.</i></p>	<p>DATE 12/29/81</p>	<p>SCALE FULL</p>	
	<p>MECH CHK</p>	<p>DATE</p>		
	<p>ELEC CHK</p>	<p>FINISH</p>		
<p>ASSEMBLY DRAWING          MS. PAC-MAN AUX P          A084 - 91415- B617</p>				

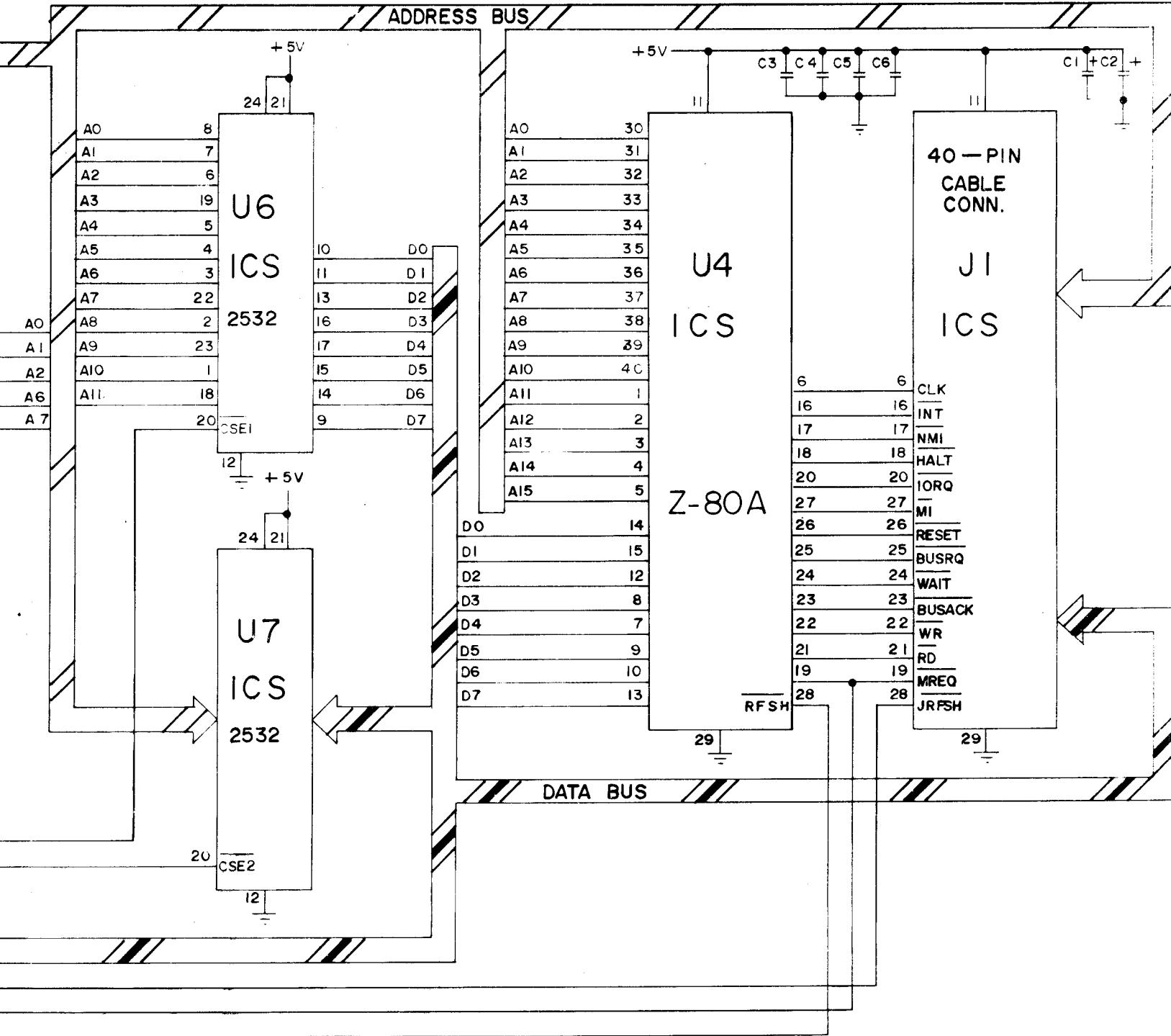

**NOTE:**

C1, C2 - 10 MF ELEC. CAP  
 C3-C6 - 1MF CER CAP

ZERSZEN

THIS DRAWING IS THE PROPERTY OF MIDWAY MFG. CO.

MS. PAC-MAN



1/4/81

FULL

MS. PAC-MAN P.C.  
 A084-91415-8617  
 SCHEMATIC

REVISIONS

M051 00617 B002

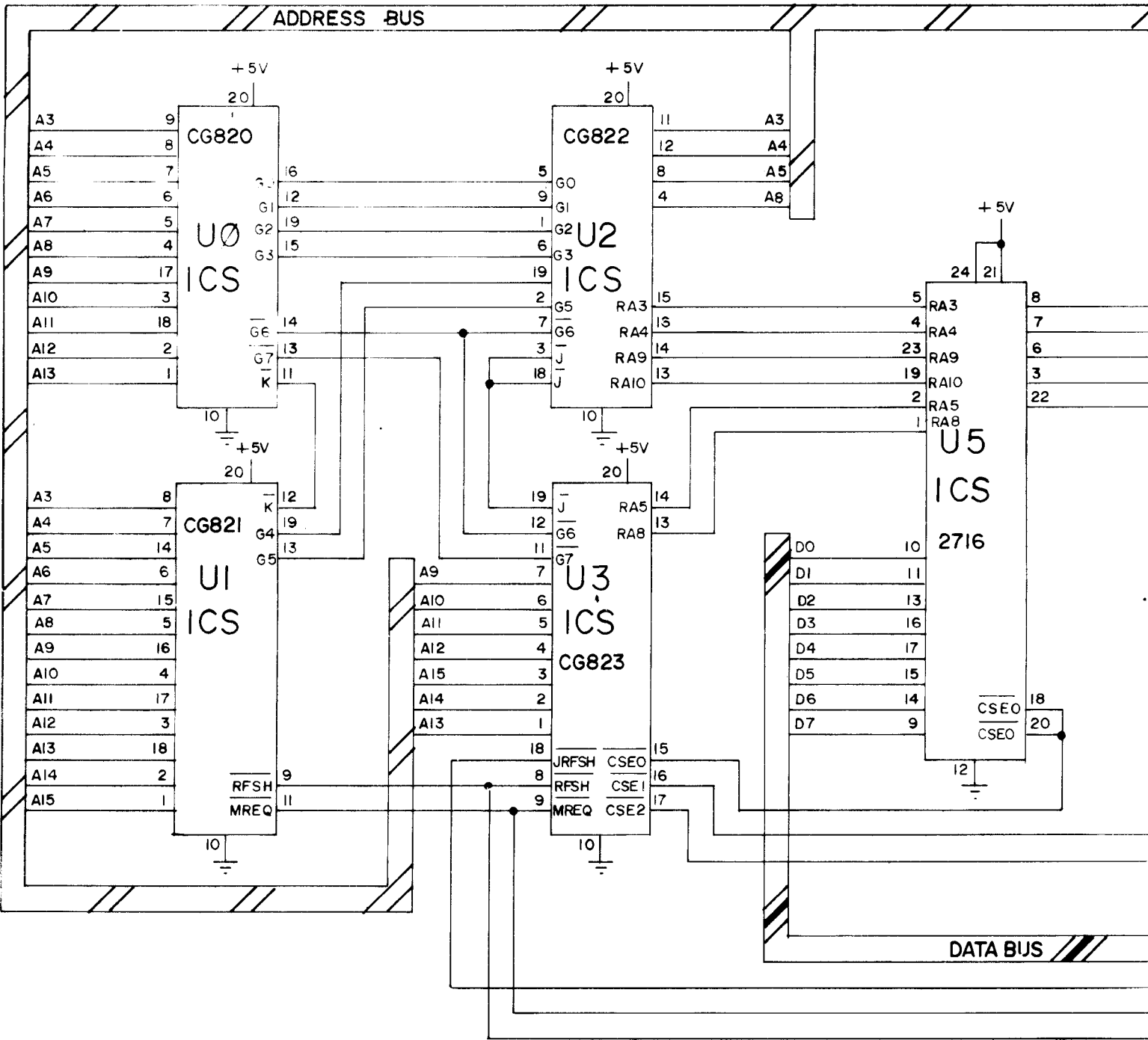

PROJECT ENG: J. SZEP

DIM TOLERANCES  
UNLESS OTHERWISE SPEC  
CONCENTRICITY  
FRACTIONAL  
E-M  
HOLE DIA  
ANNU  
DO NOT SCALE DWG

77

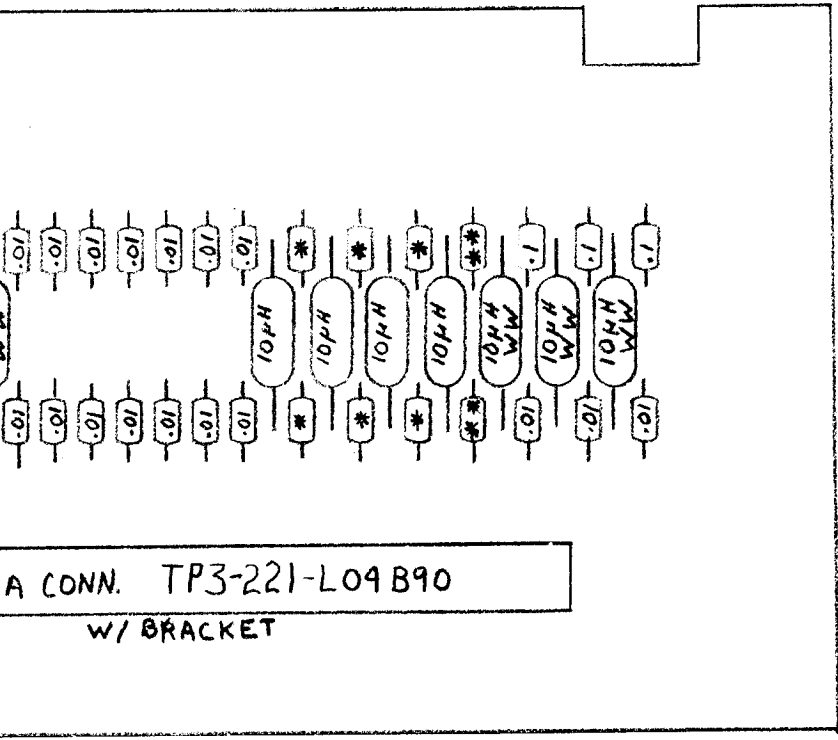

\* 100 Pf  
 \*\* 470 Pf

A CONN. TP3-221-L04B90  
 W/ BRACKET

REVISIONS		

	HEAT TREAT	SCALE	USED ON	<b>MIDWAY MFG. CO.</b> FRANKLIN PK. ILL.
		FULL	PAC-MAN	
	MAT'L.	ASSMB. DRWG PAC-MAN FILTER P.C	NO. REQ'D	PART NO. A082-91389-0000
	FINISH		1 PER	
2-11-81				

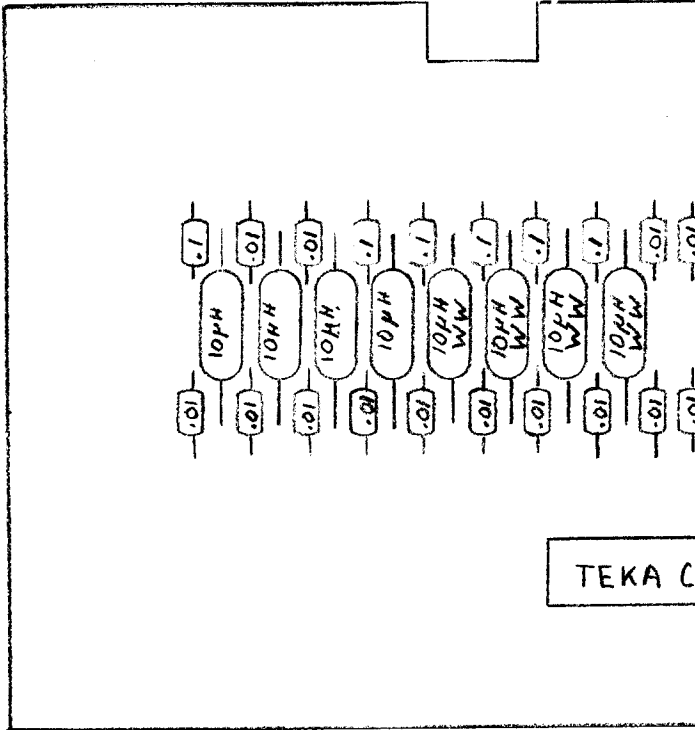

M051-00932-D037

<b>DO NOT SCALE DWG.</b>	
<b>DIM. TOLERANCES UNLESS SPECIFIED</b>	DRN. TJK
CONCENTRICITY T.I.R. .003	CKD.
FRACTIONAL..... ± 1/64	DATE 02-11
DECIMAL..... ± .005	
HOLE DIA..... +.002—-.000	

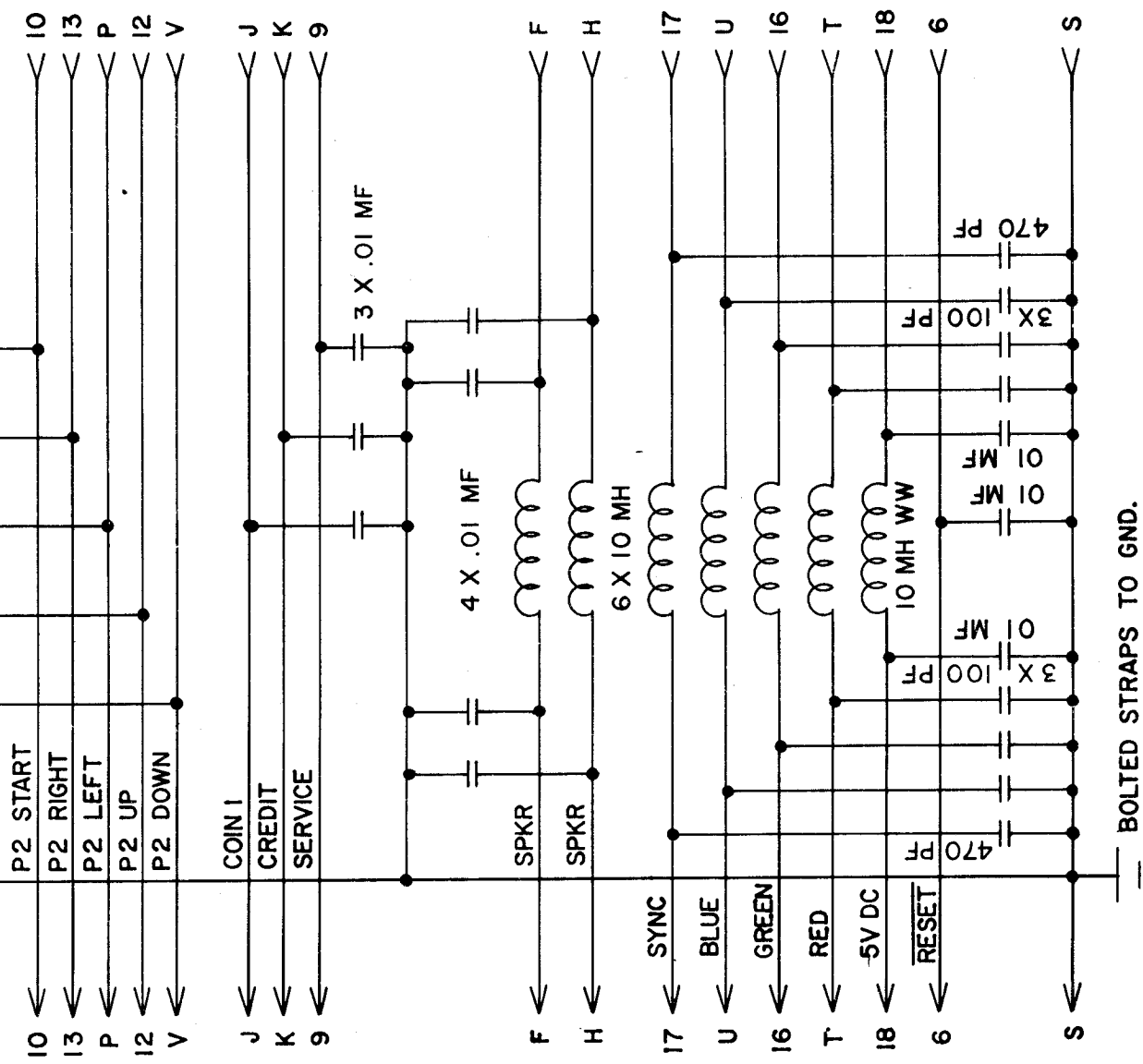

HEAT TREAT		SCALE		USED ON PAC-MAN		REVISIONS	
MATERIAL		NO REQ'D 1 PER		<b>MIDWAY MFG. CO.</b>			
FINISH		SCHEMATIC DIAGRAM PAC-MAN FILTER P.C.				FRANKLIN PK ILL	
		PART NO				A082-91389-0000	

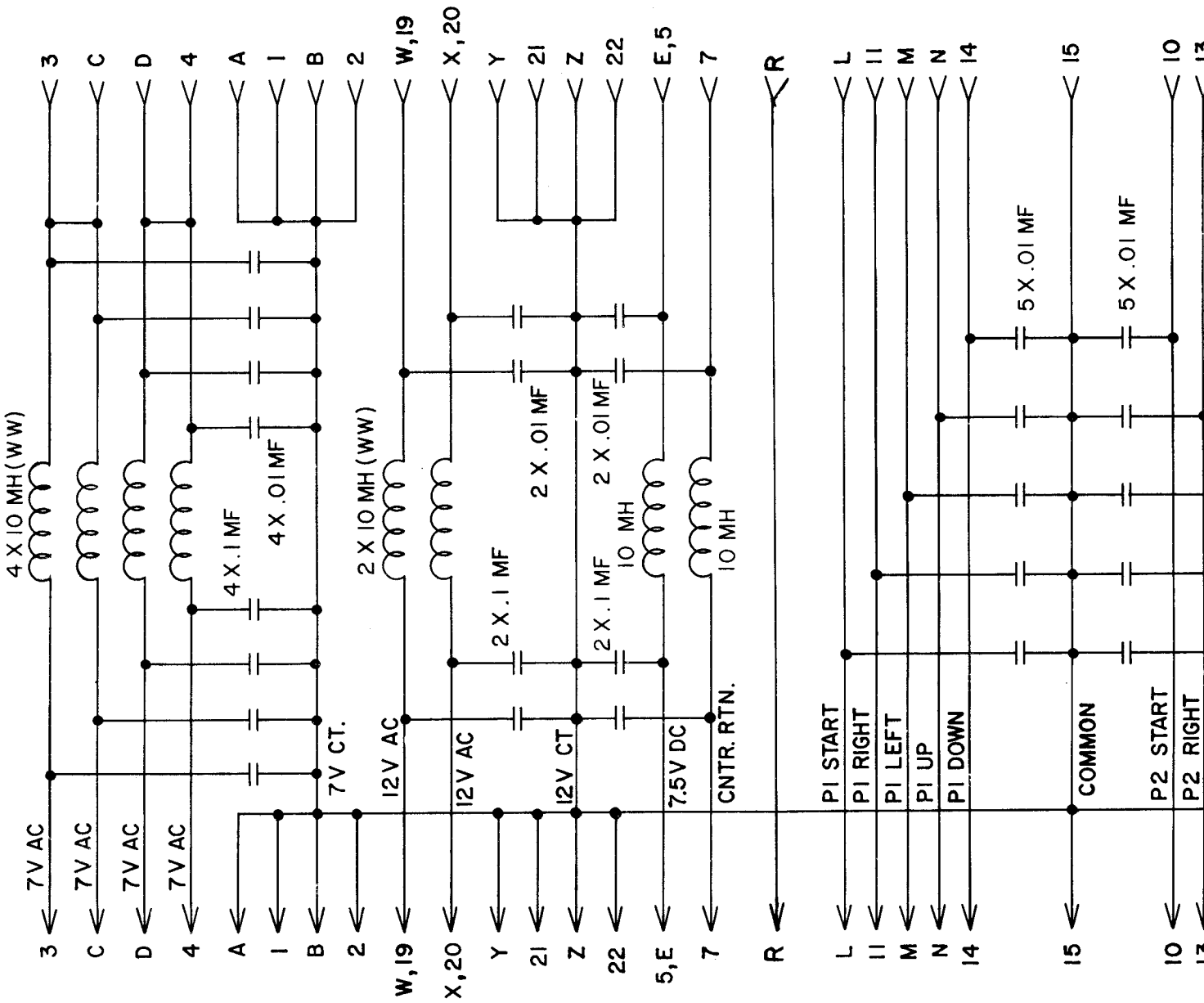

M051-00932-D038

DO NOT SCALE DWG	
DIM TOLERANCES UNLESS SPECIFIED	DWN <i>CV</i>
CONCENTRICITY ± 0.04	CHKD
FRACTIONAL ± 0.04	DATE 02-11-81
DECIMAL ± 0.05	
HOLE DIA ± 0.02 0.05	



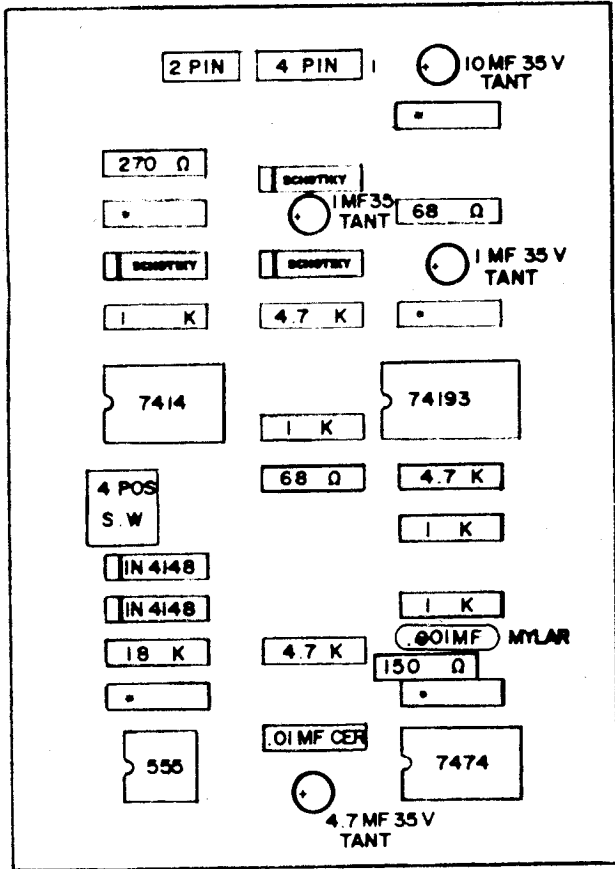

1 MF 50 V CER. AX.

SCHOTTKY DIODE - IN5818 OR IN5817

MOSI-00932-A027

USED ON PAC-MAN

NO REQ'D

SCALE

HEAT TREAT

MAT'L

FINISH

ASSEMBLY DRAWING  
CREDIT MULTIPLIER P.C

**MIDWAY MFG. CO.**

FRANKLIN PK ILL

PART NO

A082-91348-C000

REVISIONS

DO NOT SCALE DWG

DIM TOLERANCES UNLESS SPECIFIED

CONCENTRICITY TYP 003

FRACTIONAL DECIMAL .003

MOLE DIA + .003 .000

ORN *cy*

CKD

DATE

10/22/80

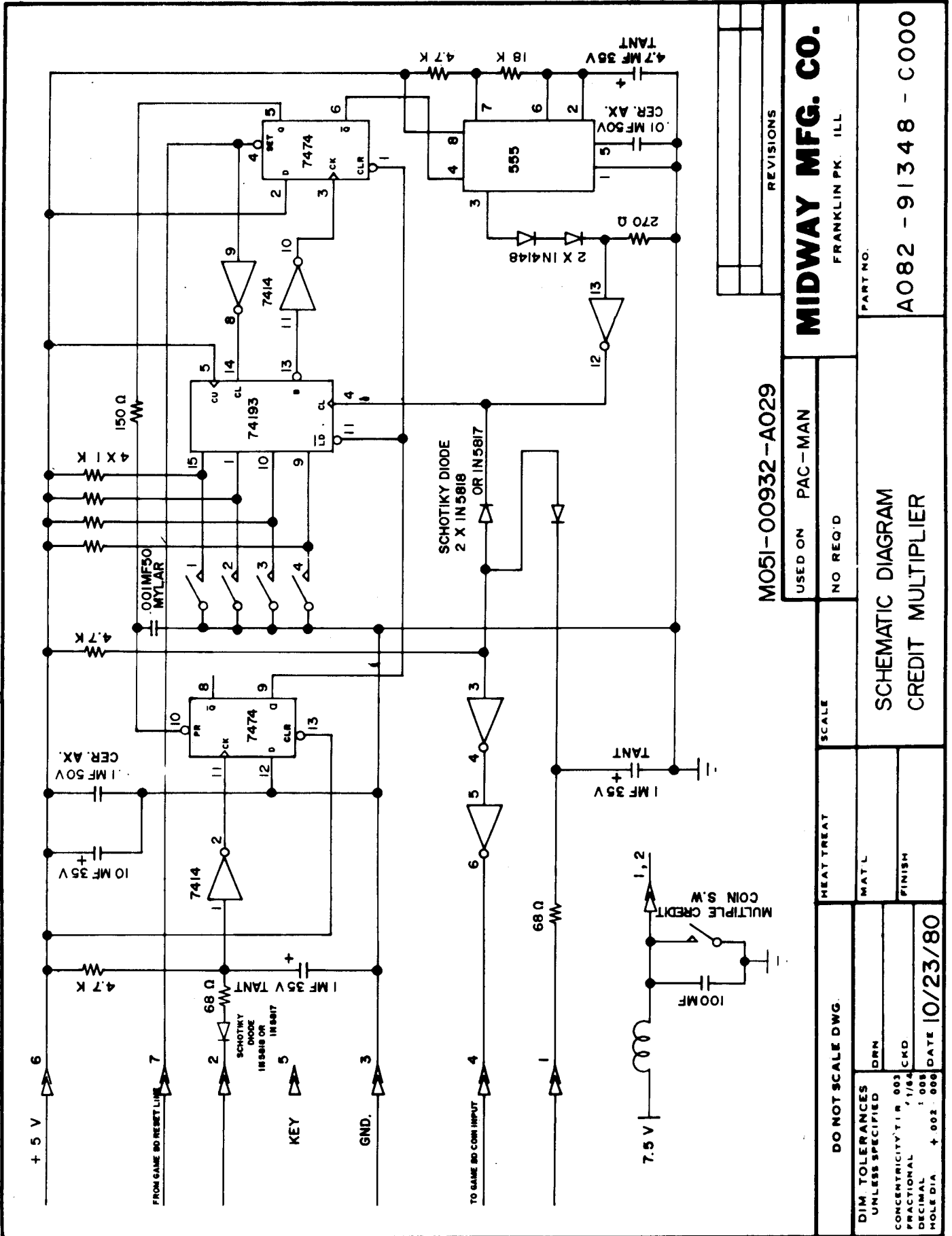

REVISIONS	
MIDWAY MFG. CO.	
FRANKLIN PK. ILL	

M051-00932-A029	USED ON PAC-MAN	NO REQ'D
-----------------	-----------------	----------

SCHEMATIC DIAGRAM		SCALE
CREDIT MULTIPLIER		HEAT TREAT
		MAT'L
		FINISH

DO NOT SCALE DWG.		DATE 10/23/80
DIM TOLERANCES UNLESS SPECIFIED		DRN
CONCENTRICITY 1/100		CKD
FRACTIONAL 1/16		DATE 10/23/80
HOLE DIA +.002		000