

Midway's

GAME NO. 594
MAY, 1975

WHEELS II

PARTS CATALOG

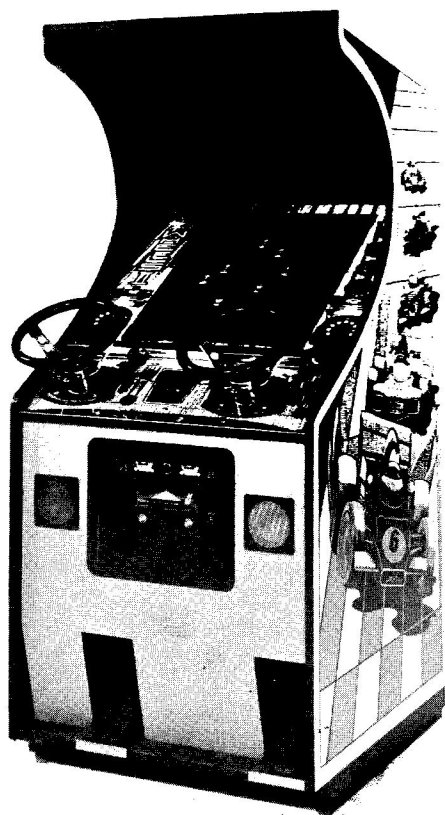

HI-BOY



LO-BOY

MIDWAY MFG. CO.
10750 WEST GRAND AVENUE
FRANKLIN PARK, ILLINOIS, 60131, U. S. A.

PHONE: (312) 451-1360

CABLE ADDRESS: MIDCO

TELEX NO.: 72-1596

TABLE OF CONTENTS

	Page No.
GENERAL INSTRUCTIONS	1
GAME ADJUSTMENTS	2
TROUBLE SHOOTING SOUND SYSTEM	3
WHEELS II—HI-BOY	4—5
WHEELS II—LO-BOY	6—7
STEERING WHEEL ASSEMBLY	8—9
GEAR SHIFT ASSEMBLY	10—11
ACCELERATOR PEDAL UNIT ASSEMBLY	12—13
ADDITIONAL PARTS LIST	14—15
PARTS LAYOUT	Inside Back Cover

GENERAL INSTRUCTIONS FOR "WHEELS II"

INSTALLATION:

Fasten four provided leg levelers to bottom of cabinet. The power is controlled by a switch located on the lower back wall of the cabinet. Plug into A.C. only, 115 volts, 60 cycles.

EXTENDED PLAY ADJUSTMENT SWITCH:

Located on Logic Unit (PC 594-904) and is adjustable from 300 to 600 points. See adjustment instructions located in back box area.

1ST AND 2ND PLAYER VOLUME CONTROL POTS:

Located on Logic Unit (PC 594-904) volume may be set by rotating pots as indicated on instructions in back box area.

GAME TIME POT:

Located on Logic Unit (PC 594-904) and may be increased by rotating pot as indicated on instructions in back box area.

ANTI-STATIC ADJUSTMENT POT:

Located on Logic Unit (PC 594-904) this pot is provided so that each game may be adjusted to the locations static conditions. Rotate pot as indicated to increase sensitivity. This control puts unit in a game-over condition when a static shock is applied.

VOLTAGE CONTROL POT:

Located on Power Supply Unit (PC 594-903) this voltage is pre-set at the factory and should not be tampered with. In event the Power Supply must be changed, adjust voltage to 5 volts by rotating pot as indicated on Power Supply.

OBJECT CAR ACCELERATOR POT:

Located on Logic Unit (PC 594-904) this pot is pre-set at the factory and should not be tampered with.

TRACK SPEED:

Located on Logic Unit (PC 594-904) this pot controls the speed at which the track runs. This control is pre-set at the factory and should not be tampered with.

WHEELS II GAME ADJUSTMENTS

1. Preset Power Supply voltage to 5.1 volt D.C. before inserting Logic Board.
2. Preset anti-static pot to minimum sensitivity, short out tilt switch with jumper, start game and increase anti-static pot control until game goes into game-over condition, remove jumper.
3. Adjust accelerator pots to a point where distinct car idle sound can be heard from each one of the speakers, make sure controlled car wheels are not turning or modulating.
4. Adjust controlled car acceleration pot for proper acceleration speed.
5. With timer pot set at maximum time, check for race car program, additional race car is programmed at score of 200, 300, 400 and subject program remains for duration of the game.
6. Set game timer to 1 minute 20 seconds.
7. Set extended play to 400.
8. Adjust track speed for appropriate speed, where good player with 2 crashes can barely obtain extended play during regulation time.

*CLOCKWISE IS DEFINED AS VIEWED FROM FACE OF POT.

- A. 1ST PLAYER VOLUME CONTROL:
To increase, rotate pot clockwise.
- B. 2ND PLAYER VOLUME CONTROL:
To increase, rotate pot clockwise.
- C. OBJECT CAR ACCELERATOR CONTROL: Pre-set at factory and should not be tampered with.
- D. TRACK SPEED CONTROL:
To increase track speed, rotate pot counter-clockwise.
- E. GAME TIME CONTROL:
To increase game time, rotate pot counter-clockwise.
- F. ANTI-STATIC CONTROL:
To increase sensitivity, rotate pot clockwise.

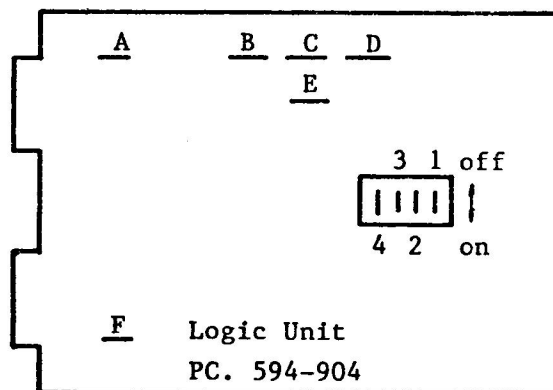

EXTENDED PLAY SWITCH

- SW 1 ON = 300
- SW 2 ON = 400
- SW 3 ON = 500
- SW 4 ON = 600

CAUTION

**TRACK SPEED ADJUSTMENT AFFECTS GAME TIMER.
ADJUST FOR PROPER TRACK SPEED BEFORE ADJUSTING TIMER.**

MIDWAY MFG. CO.

10750 WEST GRAND AVENUE
PAGE 2

FRANKLIN PARK, ILLINOIS

WHEELS II
TROUBLE SHOOTING SOUND SYSTEM

COMPLAINT:

Loss of car and crash sounds. (Either Player)

Check the following:

1. Logic PC Board volume control setting 10K pot (two)
2. Front speakers and associated wiring (8 ohms)
3. Power supply jack connections +12 VDC #8, -12 VDC pin, #16 and gray pin #5 (PC 594-903)
4. No #1 Logic PC Board edge connector pins #6, #7, #8, and #11.
5. Logic PC Board audio generation, amplifier and muting circuits. (PC 594-904)

COMPLAINT:

Poor Sound

Check the following:

1. Damaged speaker cone
2. Speaker mounted loose
3. Logic PC Board audio generation (PC 591-904)

NOTE: The TV monitor sound system is not used.

NO. 594 - WHEELS II - HI BOY

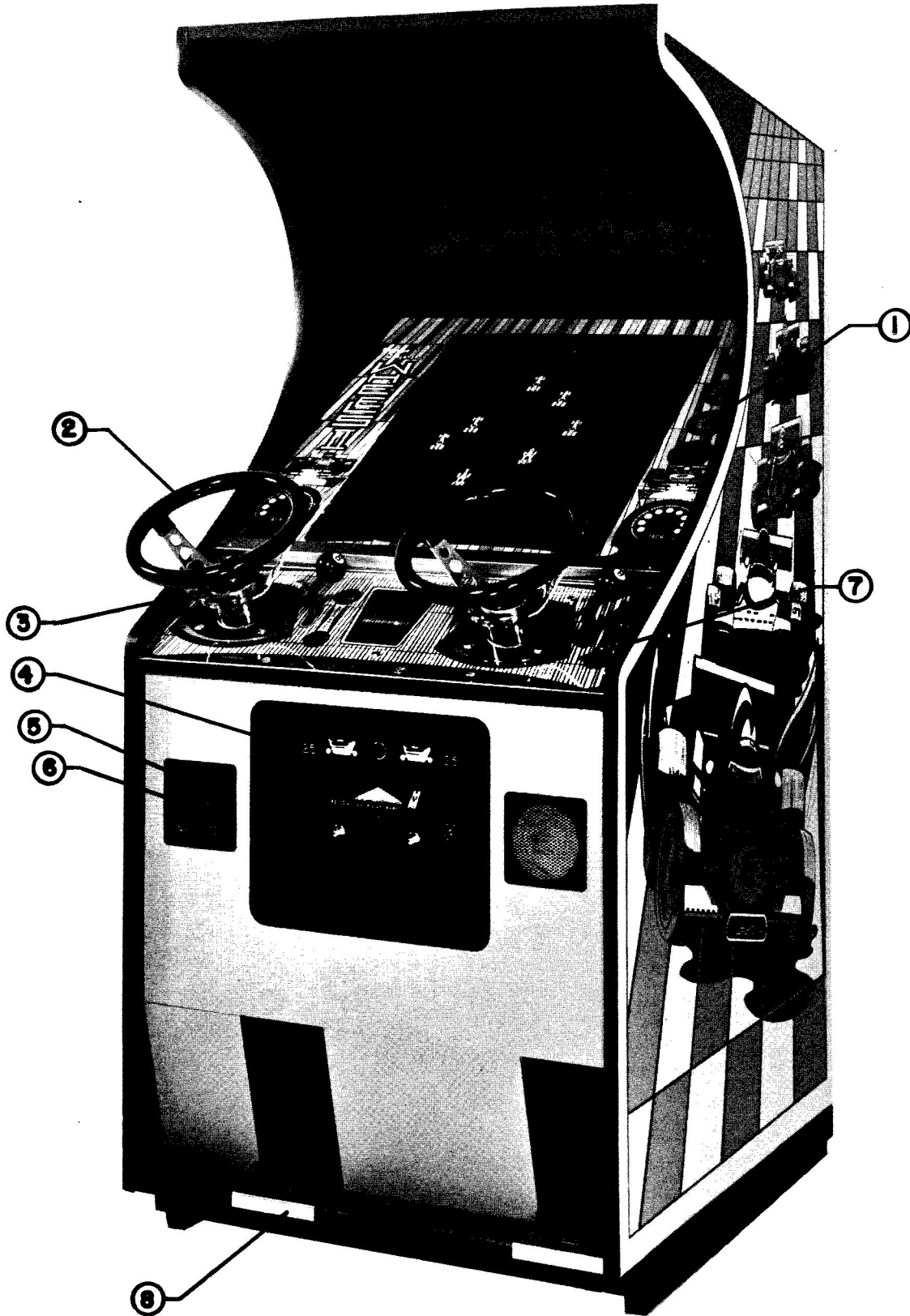

MIDWAY MFG. CO.

NO. 594 WHEELS II - HI-BOY

PRICE LIST

ORDER BY PART NUMBER ONLY

ITEM	PART NO	DESCRIPTION	PRICE
1	594-901	TEMPERED DISPLAY GLASS	49.90
2	17-9-208	STEERING WHEEL 10" DIA.	22.30
3	552-009	HORN BUTTON ASSEMBLY	4.00
4	90-020-2	COMPLETE FRONT DOOR ASSEMBLY	95.00
5	547-035	SPEAKER BEZEL	2.00
6	549-128	SPEAKER GRILL	1.00
7	594-900	CONTROL PLATE	17.00
8	591-125	PEDAL WEAR PLATE	1.00
	17-3-140	23" MONITOR T.V.	390.00

MIDWAY MFG. CO.

PRICES SUBJECT TO CHANGE WITHOUT NOTICE

PAGE 5

NO. 594 - WHEELS II - LO BOY

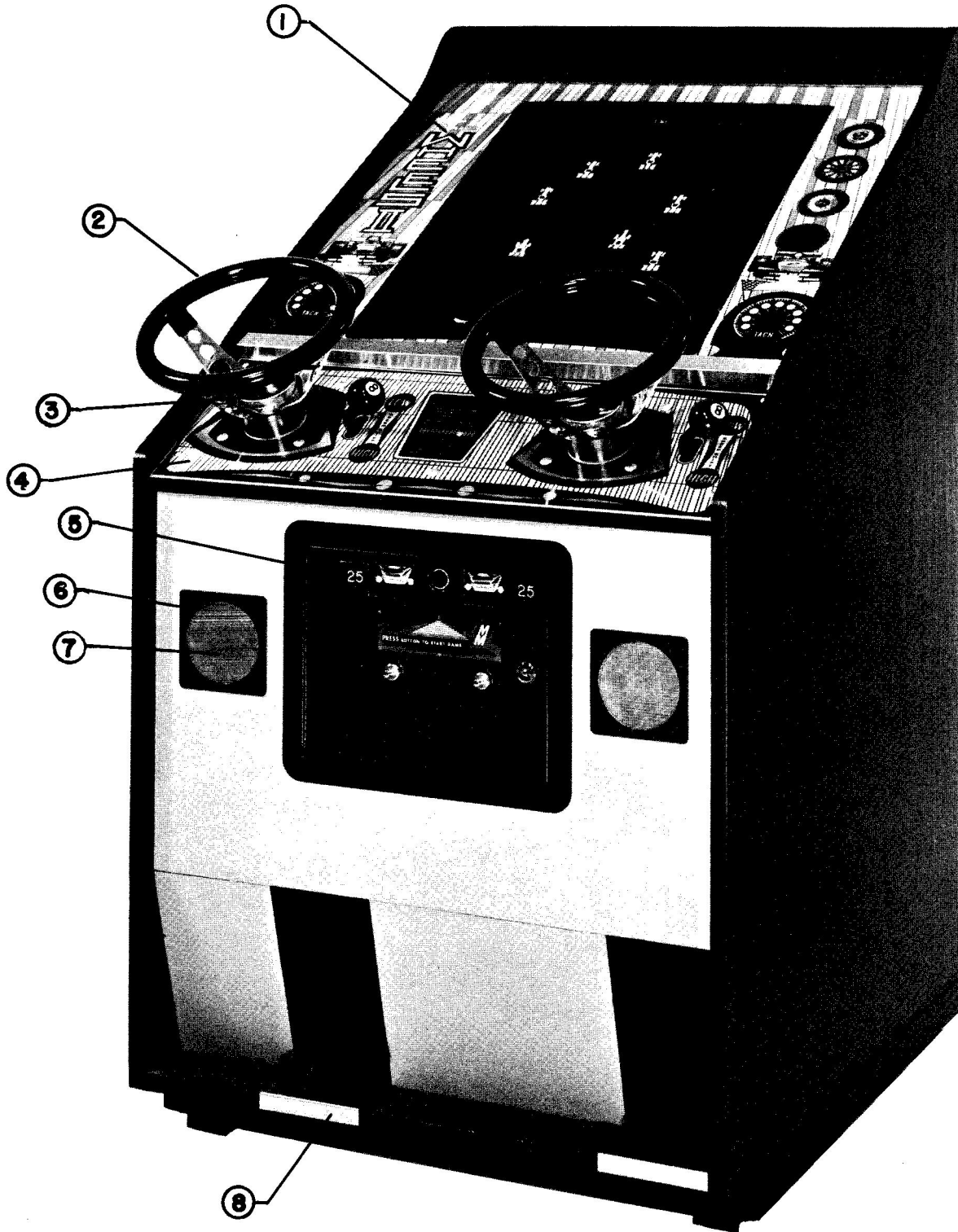

MIDWAY MFG. CO.

NO. 594 WHEELS II - LO-BOY

PRICE LIST

ORDER BY PART NUMBER ONLY

ITEM	PART NO	DESCRIPTION	PRICE
1	594-901	TEMPERED DISPLAY GLASS	49.90
2	17-9-208	STEERING WHEEL 10" DIA.	22.30
3	552-009	HORN BUTTON ASSEMBLY	4.00
4	594-900	CONTROL PLATE	17.00
5	90-020-2	COMPLETE FRONT DOOR ASSEMBLY	95.00
6	547-035	SPEAKER BEZEL	2.00
7	549-128	SPEAKER GRILL	1.00
8	591-125	PEDAL WEAR PLATE	1.00
	17-3-140	23" MONITOR T.V.	390.00

MIDWAY MFG. CO.

PRICES SUBJECT TO CHANGE WITHOUT NOTICE

PAGE 7

NO. 594 WHEELS II - STEERING WHEEL ASSEMBLY

PRICE LIST*ORDER BY PART NUMBER ONLY*

ITEM	PART N ^o	DESCRIPTION	PRICE
1	17-7-45	1/8 X 1-1/4 COTTER PIN	.20
2	17-104-54	FLAT WASHER	.20
3	10-213	CLUTCH SPRING	.20
4	591-004	CLUTCH WASHER & BUSHING SUB. ASSY.	2.10
5	17-14-11	CLUTCH POT - 25K	7.00
6	591-007	GEAR & WASHER SUB. ASSEMBLY	4.60
7	17-104-59	FLAT WASHER .510 X 1-5/8 X 3/32 THK.	.20
8	17-9-88	BEARING	8.70
9	591-105	POT LOCATOR	1.60
10	17-101-308	8-32 X 3/16 SETS	.20
11	591-003	SHAFT & GEAR SUB. ASSEMBLY	3.80
12	591-005	BRACKET & POST SUB. ASSEMBLY	.90
13	594-001	MAIN MTG. BRKT. & BUSHING SUB. ASSY.	6.00
14	594-101	STEERING MTG. PLATE	1.30
15	17-102-19	1/4 X 20 X 1 1/2 CARR. BOLT BRIGHT NIC. PLT.	.20
17	552-119	STEERING POST SHIELD	2.40
18	17-104-56	1" X 1 1/2 X 1/16 FLT. WASHER	.20
19	552-008	STEERING HUB FLANGE SUB. ASSY.	11.60
20	594-905	NYLON WASHER - (2)	.20 EA.

MIDWAY MFG. CO.

PRICES SUBJECT TO CHANGE WITHOUT NOTICE

PAGE 9

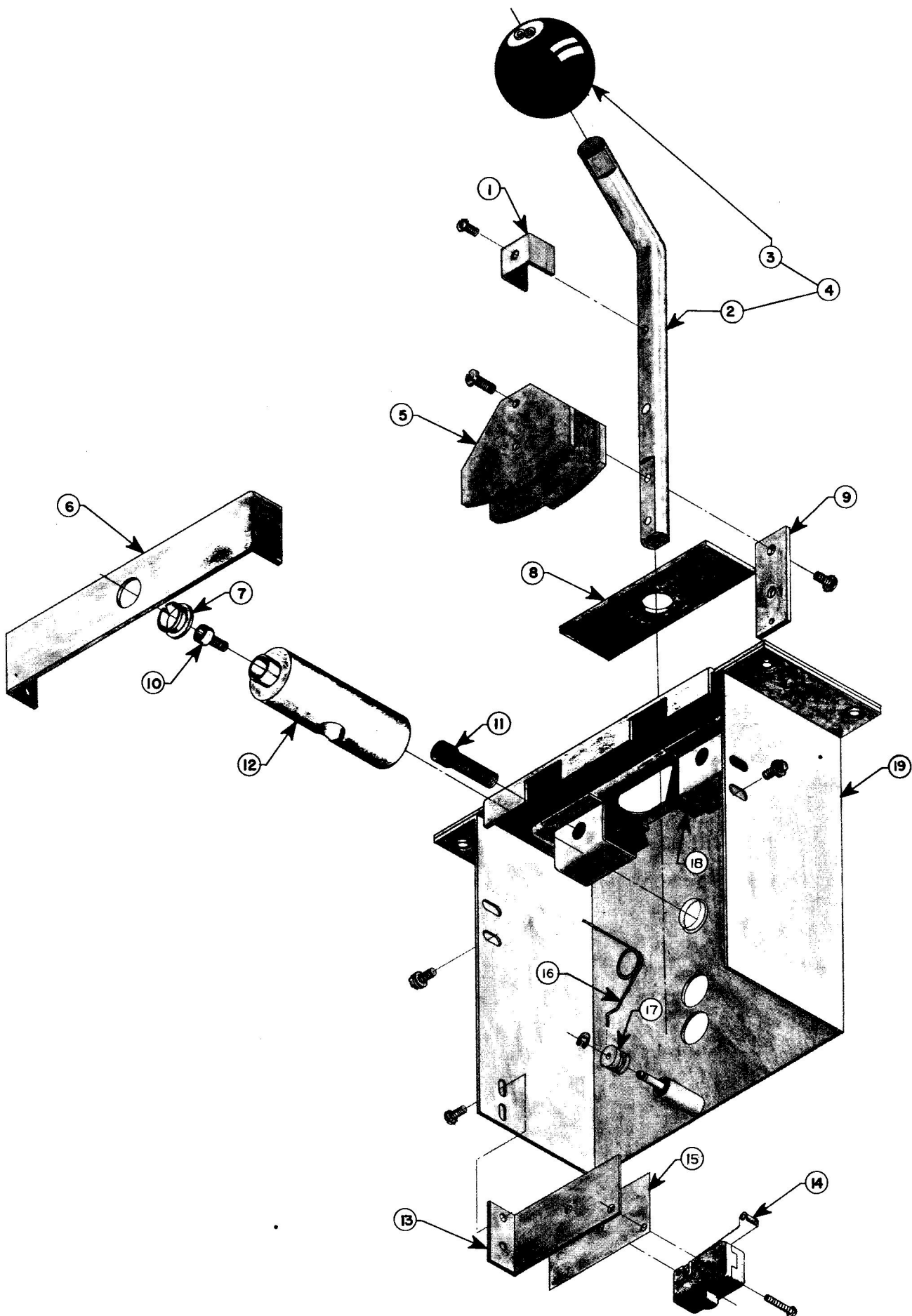

NO. 594 WHEELS II - GEAR SHIFT ASSEMBLY

PRICE LIST

ORDER BY PART NUMBER ONLY

ITEM	PART NO	DESCRIPTION	PRICE
1	591-021	U-BRACKET ASSEMBLY	.60
2	594-700	SHIFT - ROD	5.10
3	594-701	BALL	2.60
4	594-003	BALL & ROD ASSEMBLY	9.20
5	591-103	SWITCH ACTUATOR	.40
6	591-114	BEARING SUPPORT PLATE	.70
7	17-42-21	NYLINER	.30
8	591-902	SLIDE	.30
9	591-118	SPRING PLATE	.70
10	17-101-720	10-32 X 3/4 SOCKET CAP MACH. SCREW	.50
11	17-102-65	5/16-18 X 3/4 LG. SOCKET HEAD CAP M.S.-(2)	.20 EA.
12	591-703	PIVOT BUSHING	4.40
13	591-120	SWITCH MOUNTING BRACKET	.70
14	17-150-32-09	CHERRY SWITCH	2.70
15	588-911	INSULATOR	.20
16	10-227	TORSION SPRING	.60
17	591-702	SPRING ROLLER	.50
18	544-907	RUBBER BUMPER	.20
19	591-010	CONTROL HOUSING	11.60

MIDWAY MFG. CO.

PRICES SUBJECT TO CHANGE WITHOUT NOTICE

NO. 594 WHEELS II ——— ACCELERATOR PEDAL ASSY.

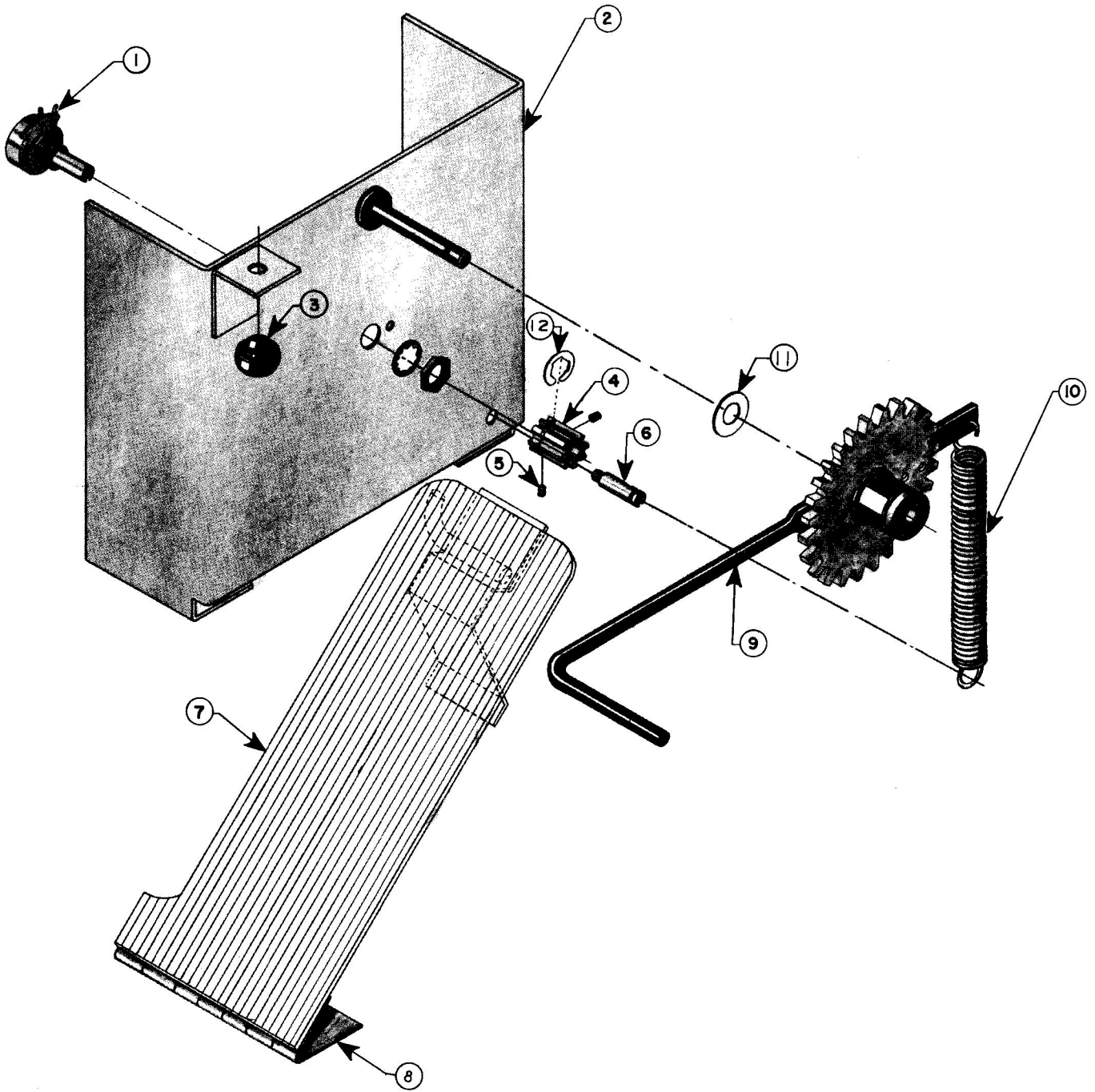

MIDWAY MFG. CO.

NO. 594 WHEELS II – ACCELERATOR PEDAL UNIT ASSEMBLY

PRICE LIST

ORDER BY PART NUMBER ONLY

ITEM	PART NO	DESCRIPTION	PRICE
1	17-13-143	5K POT	5.00
2	591-014	MOUNTING BRACKET ASSEMBLY	5.70
3	17-41-15	RUBBER BUMPER	.20
4	583-723	GEAR	2.10
5	17-101-308	8-32 X 3/16 SOCKET SET SCREW – (2)	.20 EA.
6	11-100-5	STUD	.30
7	591-910	ACCELERATOR PEDAL COVER (RUBBER)	1.60
8	591-002	ACCELERATOR PEDAL & HINGE ASSEMBLY (W/O RUBBER)	3.50
9	591-013	GEAR & LEVER ASSEMBLY	10.20
10	10-228	SPRING	.50
11	17-104-28	1/2 X 5/16 X 1/32 WASHER	.20
12	17-100-50	“E” RING – 1/2”	.20

MIDWAY MFG. CO.

PRICES SUBJECT TO CHANGE WITHOUT NOTICE

PAGE 13

PRICE LIST**ARRANGED IN NUMERICAL ORDER**

PART NO.	DESCRIPTION	PRICE
MT-46	TRANSFORMER	23.60
17-3-55	LAMPS	.20
17-3-114	CORCOM FILTER	12.00
17-21-103	22 PIN EDGE CONNECTOR	8.90
17-91-50	GREEN ACETATE SHEET	3.00
17-050-5-46	BACK DOOR LOCK	3.40
17-086-31-02	SOCKETS	.20
17-093-102-48	LEG LEVELERS	.60
17-101-639	8-32 X 1¼ CARRIAGE BOLT (CONTROL P.C.)	.20
17-101-665	10-32 X 7/8 WHIZZ MACH. SCREW (T.V. SET)	.20
17-101-672	CARRIAGE BOLTS (MONITOR)	.20
17-103-26	LEG LEVELER NUTS	.20
566-120	CASH BOX	5.80
566-121	CASH BOX COVER	1.70
567-003	P.C. SUPPORT ASSEMBLY - LONG	15.60
567-106-1	SWITCH MOUNTING PLATE	.60
567-113	COUNTER BRACKET	.40
572-103	VENT GRILL	4.40
591-015	ACCELERATOR PEDAL ASSY. (COMPLETE)	33.90
591-017	P.C. SUPPORT ASSEMBLY - SHORT	8.20
591-904-1	TREAD RUBBER	1.70
592-001	H. V. CHASSIS BRACKET	1.70
592-002	LOCK BRACKET ASSEMBLY	3.40
592-101	LOCK BRACKET	2.00
592-103	CHASSIS H. V. MOUNTING BRACKET	.50
592-104	CHASSIS MOUNTING BRACKET (L & R)	.60

MIDWAY MFG. CO.

NO. 594 WHEELS II - ADDITIONAL PARTS LIST

PRICE LIST

ARRANGED IN NUMERICAL ORDER

PART NO.	DESCRIPTION	PRICE
592-105	STIFFENER BRACKET	1.60
594-002	STEERING WHEEL ASSEMBLY (COMPLETE)	91.40
594-004	GEAR SHIFT ASSEMBLY (COMPLETE)	39.00
594-902	TREAD RUBBER	2.70
594-903	POWER SUPPLY	95.00
594-904	LOGIC BOARD	700.00
601-010	CASH BOX LOCK BRACKET	1.40

MIDWAY MFG. CO.

NOTES

This space is provided for personal notes

