

**PART NO.  
420-0199**

**MANUFACTURED BY**



**OWNER'S MANUAL**

GEE BEE  
OPERATING INSTRUCTIONS  
AND  
SERVICE MANUAL

GEE BEE OWNER'S MANUAL

Copyright © 1979 by GREMLIN INDUSTRIES, INC. All Rights Reserved  
All the information contained herein is the exclusive proprietary property  
of GREMLIN INDUSTRIES, and is disclosed in confidence and may not be  
duplicated nor copied in whole or part nor be used for any purposes other  
than that for which disclosed.

## TABLE OF CONTENTS

	PAGE
INTRODUCTION	1
IMPORTANT NOTE	2
REPACKAGING INSTRUCTIONS	3
REPLACEMENT PARTS LIST	4
TRANSFORMER VOLTAGE CONVERSION	6
GAME CONCEPT AND OPERATION	7
ADJUSTMENTS AND OPTIONS	10
MAINTENANCE AND TROUBLESHOOTING PROCEDURES	12
SCHEMATICS	Following Pages

## INTRODUCTION

This is an electronic game that makes extensive use of digital integrated circuitry and television monitor circuitry. This manual assumes the maintenance technician possesses a general knowledge of solid state circuitry, microprocessor, TTL digital integrated circuitry and T.V. monitor concepts. Any individual NOT knowledgeable in these areas SHOULD NOT attempt repair of the electronic portion of this game. IT SHOULD BE NOTED THAT ANY ATTEMPT TO REPAIR THE GAME IN THE FIELD WITHOUT EXPRESS CONSENT OF THE FACTORY WILL IMMEDIATELY VOID THE WARRANTY!!!

### IMPORTANT NOTES:

NEVER replace any components with anything other than exact replacement parts. (See Parts List located on Service Schematics.

NEVER remove circuit boards/connections while power is on.

DO NOT replace the fuse with anything other than the proper value. A blown fuse indicates an overload condition within the game. Replacing the fuse with a higher value can cause severe damage to internal components if an overload occurs.

ALWAYS consult the manual before attempting repairs.

CORRESPONDENCE regarding this game should be addressed to:

GREMLIN INDUSTRIES, INC.

8401 Aero Drive

San Diego, California 92123

(714) 277-8700

### IMPORTANT NOTE

An important service note is posted in this game and is repeated here for emphasis:

IF AT ANY TIME THE T. V. SCREEN SHOWS A MEANINGLESS DISPLAY  
OR THE GAME OTHERWISE MALFUNCTIONS, SIMPLY DROP A COIN INTO  
THE COIN MECHANISM. THIS SHOULD CORRECT THE PROBLEM. IF  
NOT, THE GAME REQUIRES SERVICE.

The circuitry in this game has been arranged so that the insertion of a quarter through the coin mechanism will reset the system. This clears up temporary problems caused by power line disturbances, static, etc.

#### SERVICE TECHNICIAN NOTE:

The system reset circuitry described above requires that the coin counter is attached to the system. If there is a coin counter problem and no replacement is available, the game will function properly if a 10K Ohm resistor is connected across the coin counter input pins to the video logic board.

## REPACKAGING INSTRUCTIONS

Should it be necessary to ship this game, follow the instructions below for game recrating:

- A) If the original shipping bolts have been discarded (Ref.1), obtain four 5/16-18x1 3/4" hex head bolts with 5/16" flat washers. Carefully lay the game on its side and attach skid (Ref.2).
- B) Place game upright. Tape game keys to upper flange of operator's panel (Ref.3). Crate the game using appropriate shock-absorbent packing material (Ref.4). Include padding on all four corners of the game (Ref.5). After crating is completed, secure package with strapping (Ref.6).

NOTE: If the game is to be shipped to GREMLIN for service or repair, attach a tag identifying the distributor and indicate the service or repair to be made; include the full serial number of the game. GAME MUST BE SHIPPED PREPAID.

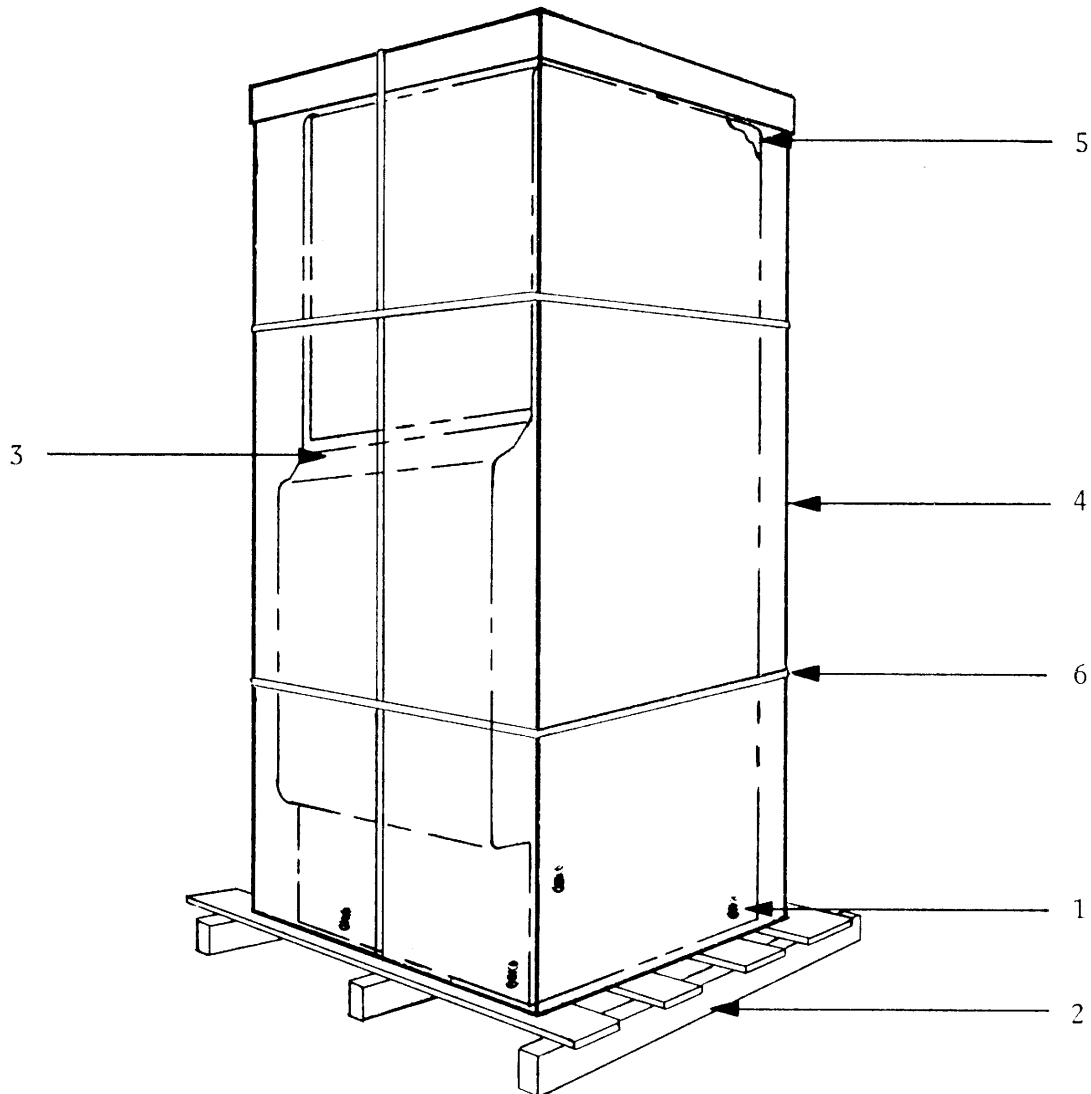

REPLACEMENT PARTS LIST- GEE BEE

1. LOGIC BOARD PARTS

GREMLIN PART NUMBER	DESCRIPTION
211-0050	44 PIN EDGE CONNECTOR
230-0023	CRYSTAL, 18.432 MHZ
313-0002	LM311N IC
313-0003	LM340 T5 7805(+5 VOLT REGULATOR)
313-0006	LM380
313-0014	LM340 T12 (+12 VOLT REGULATOR)
313-0023	LM320 T5 (-5 VOLT REGULATOR)
315-0018	2111 RAM IC
315-0019	EPROM 2708 IC
315-0046	2114/2114L RAM IC
316-0137	PROM IC 2332
510-0043	6 POSITION DIP SLIDE SWITCH
530-0008	HEATSINK

2. POWER SUPPLY

211-0042	CONNECTOR SOCKET
211-0045	CONNECTOR PLUG
560-0003	TRANSFORMER, GAME

3. CONTROL PANEL

250-0068	BRACKET (FOR VOLUME CONTROL)
250-0328	BEZEL FOR SERVE SWITCH, TAPERED
240-0092	KNOB FOR PADDLE CONTROL
475-0007	10K POT, VOLUME CONTROL
475-0016	5K POT, PADDLE CONTROL
510-0014	SLIDE SWITCH (ON BRACKET W/VOLUME)
510-0045	SERVE SWITCH, ILLUMINATED (W/BULB)
510-0046	PLAYER 1 START SWITCH (W/ BULB) LEFT
510-0047	PLAYER 2 START SWITCH (W/ BULB) RIGHT

4. COIN MECHANISM

220-0071	COIN REJECT BUTTON W/ SPRING
220-0072	COIN RETURN STOP (U-BOLT W/NUTS)
220-0074	COIN MECHANISM W/LOCKOUT COIL (U.S.B.)
	COIN LOCKOUT COIL

5. MISCELLANEOUS PARTS

130-0001

GAME SPEAKER

200-0009

WELLS GARDNER MONITOR B/W

220-0035

CABINET LOCK

420-0158

MANUAL, WELLS GARDNER MONITOR

420-0199

MANUAL, GEE BEE GAME



## GEE BEE TRANSFORMER VOLTAGE CONVERSION

TO CONVERT THE GAME TRANSFORMER (PART NO. 560-0003) TO 100, 115, OR 230 VAC, REFER TO THE FOLLOWING CHART:

FOR 100 VOLTS: CONNECT THE VOLTAGE INPUT LINES TO PINS 1 AND 2 ON THE XFMR.

FOR 115 VOLTS: CONNECT THE VOLTAGE INPUT LINES TO PINS 1 AND 3.

FOR 230 VOLTS: CONNECT THE VOLTAGE INPUT LINES TO PINS 1 AND 4, WITH PIN 3 CONNECTED TO THE LAMP CIRCUIT.

#### GAME CONCEPT:

GEE BEE is a unique one or two player ball and paddle video game. By controlling a set of paddles, players keep a ball bouncing around the screen to knock out point blocks for high score. There are also bumpers, rollovers and a spinner to aim for, all worth more points. The game accepts up to 9 credits, and each game plays either 3 or 5 balls, depending on which option is set.

#### GAME START:

When one credit is accepted, the screen displays the number, and only the one-player start button flashes. When two or more credits (up to 9) are displayed, both the one- and two- player start buttons flash. The game is adjustable for the number of coins per credit. (See Adjustments and Options)

#### GAME PLAY:

If the one-player start button is pushed, the credits count down one; when the two-player button is pushed, the credits decrease by two. Then, the SERVE button flashes and, when pushed, releases the ball onto the playfield. The ball automatically appears after 10 seconds if the serve button is not pushed.

For two-players, GEE BEE features alternate play; that is, when the first player's turn is over, the game resets to allow player two to take his turn. As the alternate action continues, the game remembers each player's score.

The paddle knob causes both paddles to move to the left and right across the screen. The ball bounces off the top side of both paddles, but passes through the upper paddle's bottom side. The ball speed varies, depending on the number of hits made for that turn. When first served, the ball moves at slow speed, then changes to medium speed after the 4th hit with the paddles. On the 8th hit, the ball speed becomes fast. When the high speed ball passes through the spinner, its speed changes to slow, then to medium after the first hit.

## SCORING:

There are three kinds of point blocks- top blocks, side blocks, and pocket blocks. When the ball hits a block, that block is erased and the points are added to the score. The point values for the blocks are as follows:

### TOP BLOCKS AND LEFT AND RIGHT SIDE BLOCKS:

Row A (outermost row)	1 block = 20 points/1 Bonus (1000 points) for erasing one row.
Row B	1 block = 50 points/1 Bonus (1000 points) for erasing one row.
Row C	1 block = 100 points/1 Bonus (1000 points) for erasing one row.

The points for the left and right pocket blocks are 100, 300, 500, 700, and 900 points, respectively, starting from the bottom of the pocket.

GEE BEE has two bumpers at the top of the screen, which give 10 points when hit. They enlarge momentarily when hit, then return to normal size. When one bank of side blocks is erased, the bumper on that side increases to 100 points. There is also a spinner between the bumpers, which gives points depending on how many times it spins. At slow ball speed, the spinner turns twice; at medium speed, it spins 4 times; and, at fast speed, it spins 6 times. The spinner is normally gray in color, but changes to white when all the top blocks are erased. One revolution is worth 10 points when the spinner is gray, and worth 100 points when it is white.

Five rollovers (circled G's) appear at the bottom of the screen, and are colored gray normally. Each circle changes from gray to white, or white to gray, when a ball passes through it. The change from gray to white is worth 50 points. If all 5 rollovers change to white, the bonus multiplier display becomes X2, and doubles the score for that turn. No further changes occur after all rollovers become white in one turn.

GEE BEE provides a safety gate to prevent the ball from leaving the playfield through either the left or right side exits. The left or right safety gate comes on when all the left or right side blocks, respectively, are knocked out. When the ball hits the safety gate once, the ball rebounds, the safety gate disappears and 500 points plus 1 bonus (1000 points) are added to the score. If the ball leaves the playfield through one of the side exits (no safety gate) 500 points plus the bonus are added to the score.

## SCORING (Continued)

Special features in the game include a chance for an extra ball if all left or right pocket blocks are erased. Then, a flashing "EXTRA BALL CHANCE" arrow appears in the playfield exit on the side with the empty pocket. If the ball leaves through the exit where the arrow is flashing, a "SAME PLAYER SHOOTS AGAIN" sign appears and one extra ball is awarded. If a safety gate is displayed in that exit, along with the extra ball signal, the ball is rebounded and an extra ball is awarded. Only one extra ball is given per turn. A free credit is given when all left AND right pocket blocks are erased. In addition, the game gives one free credit if the player's score exceeds a preselectable number. (See Adjustments and Options) The maximum score attainable is 999990; the maximum bonus points are 99000. Finally, GEE BEE produces a number of sounds that vary depending on whether the ball hits a wall, a block, or the paddles.

## ADJUSTMENTS AND OPTIONS:

### 1. SELF TEST

GEE BEE has a built-in self test, which enables the owner to check the game for proper operation quickly. By turning on the slide switch inside the coin door, the game runs through the following test:

Self test switch ON:

1. The ball moves diagonally from the lower left corner to the upper right corner of the screen without disappearing. This indicates normal operation.
2. When the ball reaches the upper right corner, the screen displays the following information:

OK or NG      For game OK, or NG for a malfunction.

2A            Test value of paddle knob - these digits change successively when the paddle knob is turned to the left or right. With the paddles turned to the right, the display indicates a number between 0 and 16. Any number BELOW 10 means normal operation.

When the paddles are turned all the way to the left, the display counts 0...1...2...3...4...5...6...7...8...9...A...B...C...D...E...F...10.... If the value is ABOVE A0, but BELOW FF, the game is functioning normally.\*

U or T        Indicates whether the game is an upright or table model.

3 or 5        Indicates the number of serve balls per game.

A,B,C, or F   For charge per game (see Chart, following).

04            For replay points (see Chart, following).

\* A note on this numbering system: The values A-F represent the DECIMAL numbers 10-15. So, a display of A0 would be a higher value than, say, 70, 80, or 90, but LESS THAN B0, C0, D0, E0, or F0. In this numbering system (called HEXADECIMAL for 16 digits, 0-F, instead of 10 digits, 0-9, in decimal) the highest 2-digit number is FF.

ADJUSTMENTS AND OPTIONS (Continued)

3. If the serve button and the one- and two- player start buttons are lit during test, normal operation is indicated.
4. The game is functioning normally if the game sounds are heard when the serve button, the one- and two- player start buttons, and coin switch are each activated.
5. Turn the self-test switch OFF.
6. The lockout coil de-activates momentarily when the test switch is turned off. The coil re-activates instantly.
7. With the test switch off, the screen displays a cross-hatch pattern for about a second. If it is desired to use this pattern for monitor adjustments, simply turn the test switch on.
8. The game counter advances one step when the self-test is run once.

II. OTHER ADJUSTMENTS:

1. Volume control -- The volume can be adjusted with the control inside the coin door.
2. OPTIONS: (number of balls per game, game charge, and replay points)

The following is a chart of options for GEE BEE, all selectable by means of 6 small slide switches located on the logic board.

OPTION	SWITCH POSITION						SYMBOL	DETAILS
	1	2	3	4	5	6		
model type	on						U	upright
	off						T	table
number of serve balls		on					3	3 balls per game
		off					5	5 balls " "
game charge			on	on			A	1 coin, 1 play
			off	on			B	1 coin, 2 plays
			on	off			C	2 coins, 1 play
			off	off			F	free game
credit level		on			on	on	00	1 credit up: 2 credits up:
		off			on	on	00	
		on			off	on	04	40000 80000
		off			off	on	06	60000 120000
		on			on	off	07	70000 140000
		off			on	off	10	100000 200000
		on			off	off	10	100000 200000
		off			off	off	15	150000 300000

## MAINTENANCE & TROUBLESHOOTING PROCEDURES:

Always check and confirm the following items when it is believed that trouble has occurred.

1. Is the power switch on?  
Forgetting to turn on the power switch is a comparatively common oversight.
2. Is the fuse intact?  
One fuse is provided on the power supply board and on the monitor board. If a fuse blows out after being replaced, it indicates trouble in another component. Always replace with the prescribed capacity fuse, as normal equipment may be damaged if larger fuses are used as a substitute.
3. Are the connectors firmly inserted?  
Poor connector connections must be considered for any trouble indication. Check all related connectors for poor contact. Although disconnected connectors are easily spotted, poor contacts are difficult to locate. The connectors should therefore be pushed in firmly and then loosened to spot poor connections. When testing the PC board connectors, always turn off the power supply. Care should also be taken in relation to the power supply on the other connectors.
4. Turn power supply off and on again.  
As the unit may return to normal if the control circuit is reset when the game seems abnormal, turn the power off and on to see if the trouble will clear up.
5. Are there any metallic objects on the PC board?  
Ensure that there are no metallic objects on the PC board, as this will be the cause of shorts. Also, refrain from putting any other objects inside the cabinet.
6. Care in circuit conductivity tests.  
When testing conductivity of the circuit with a tester, always disconnect PC board edge connector J2.

The following flow charts are printed here for a logical, step-by-step approach to trouble-shooting the game, should that be necessary.

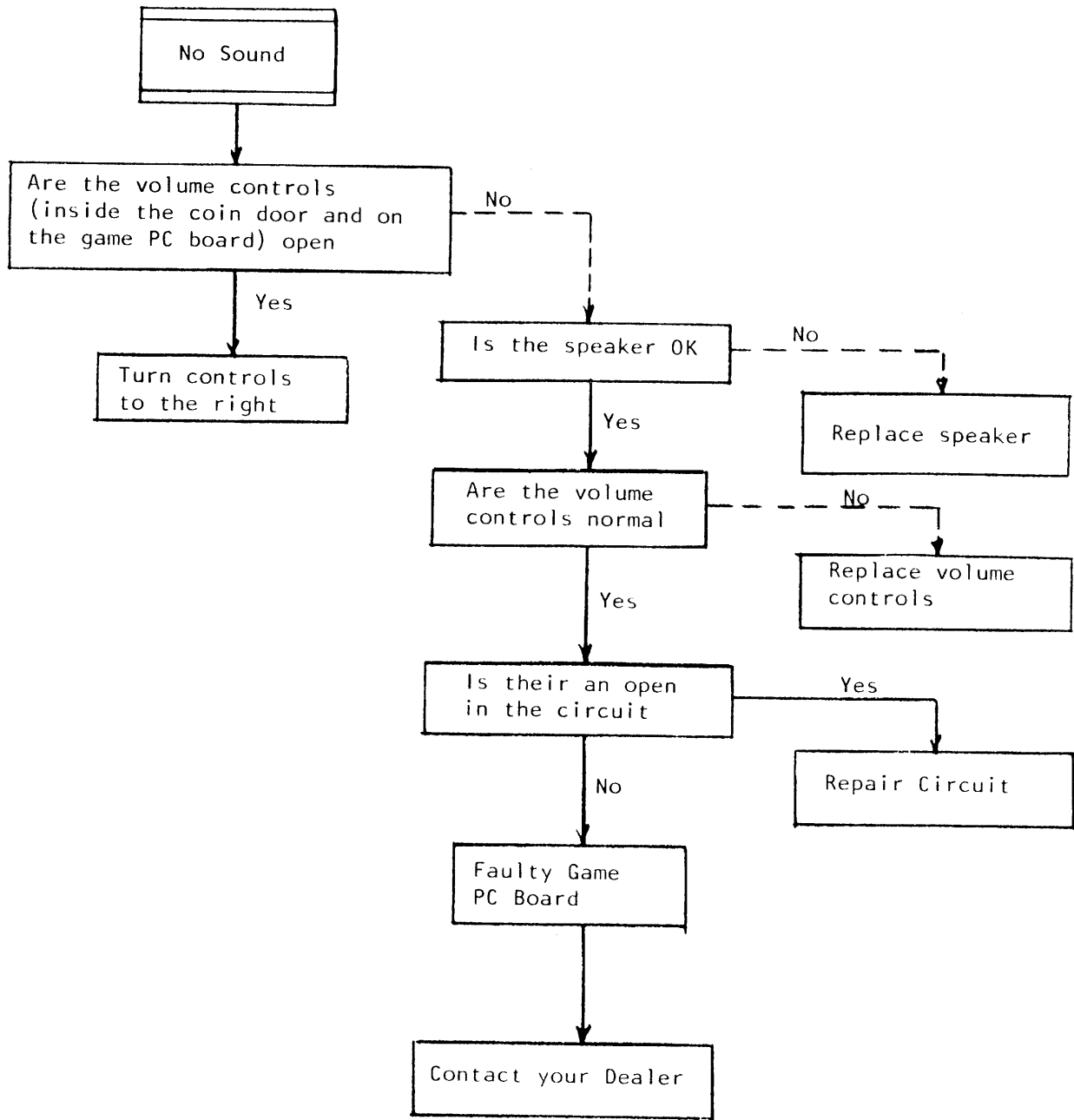



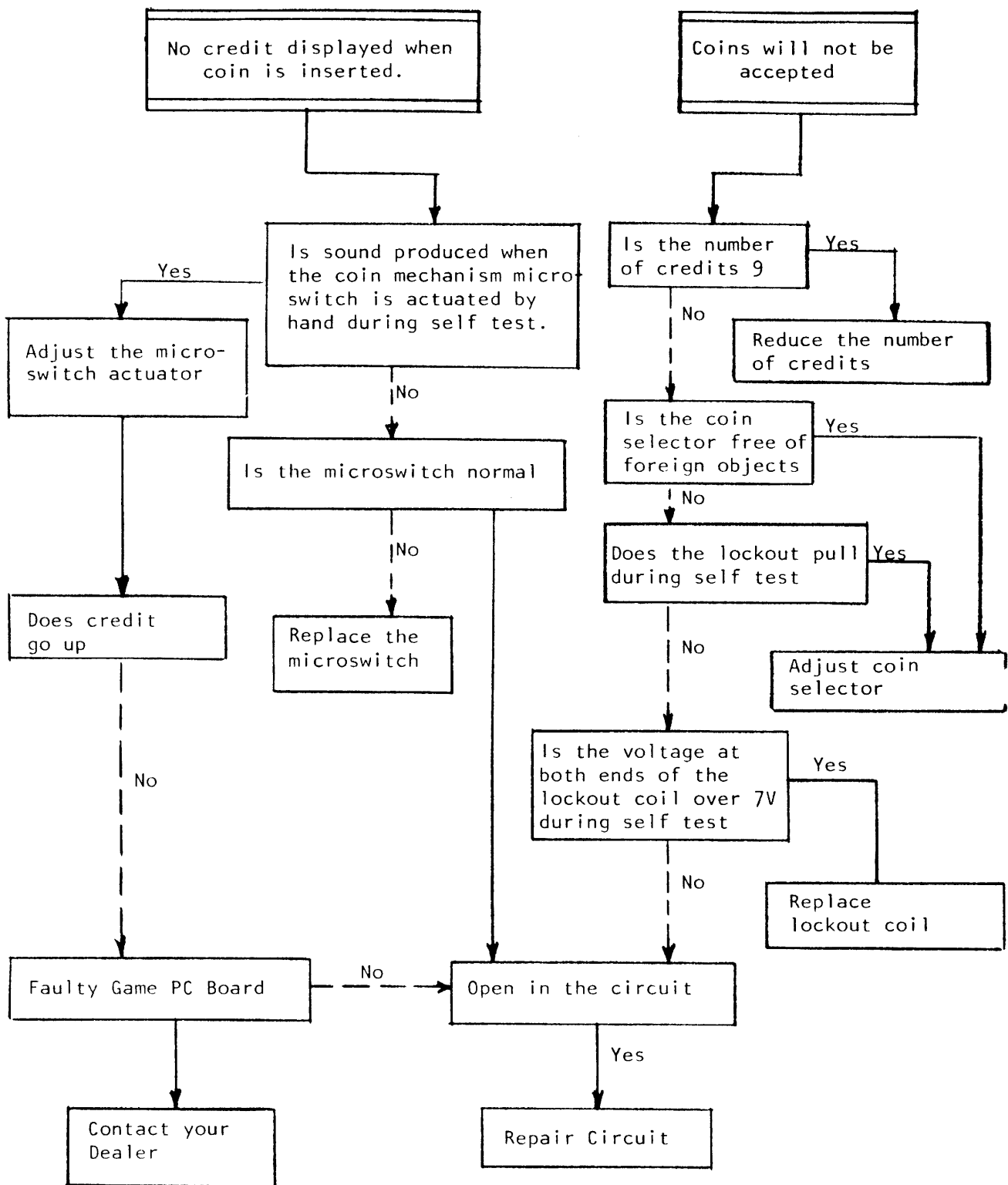

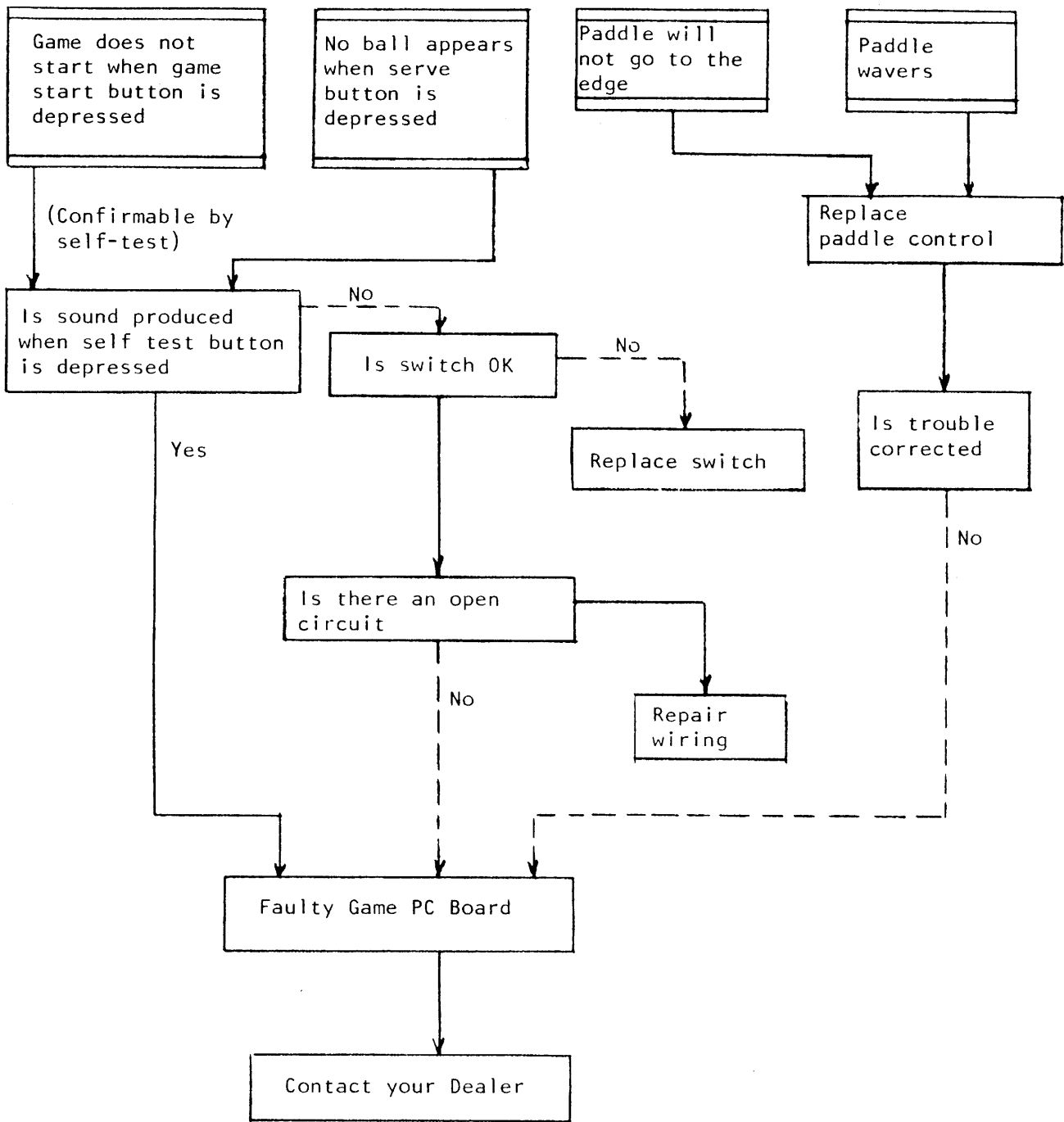

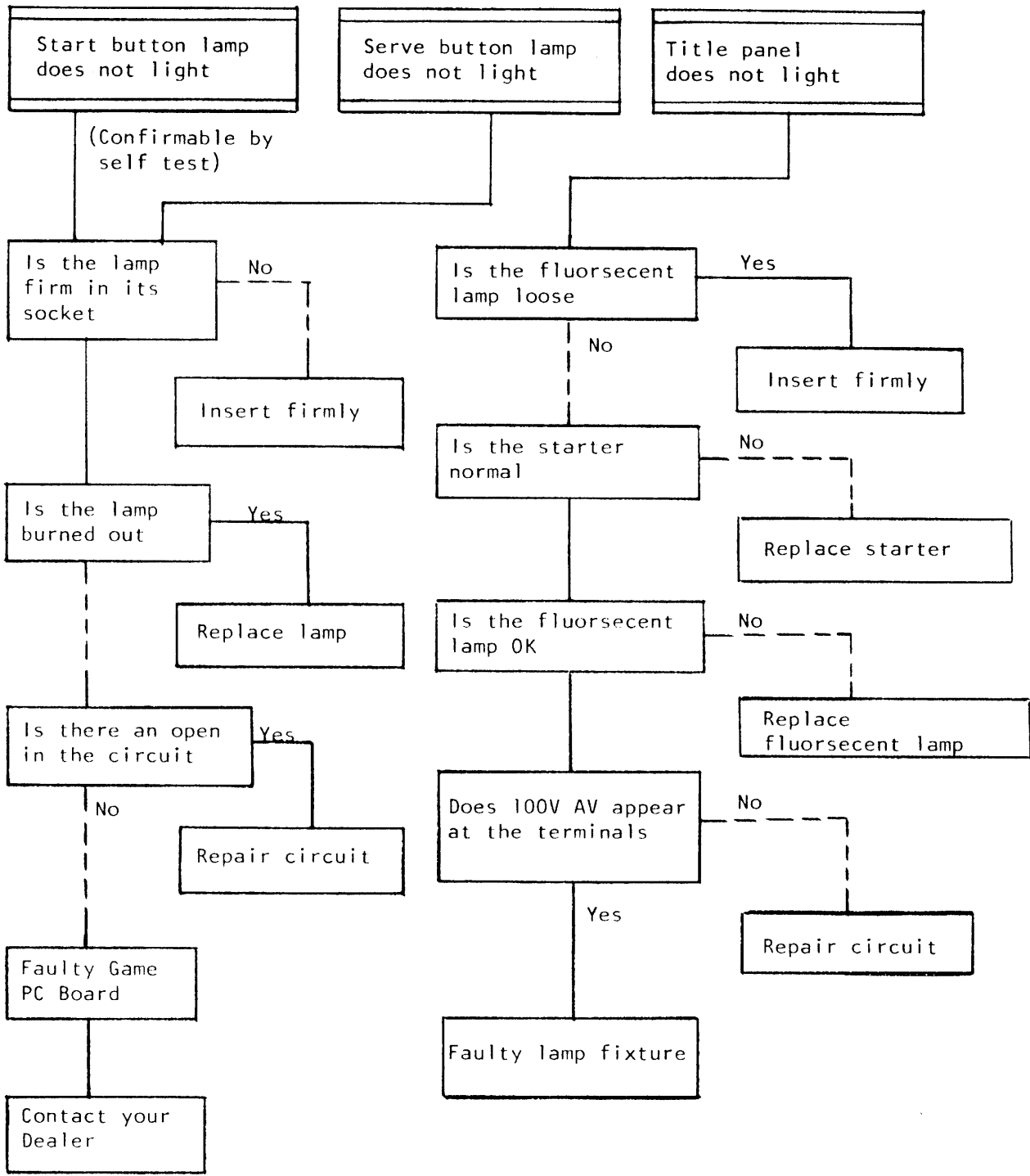

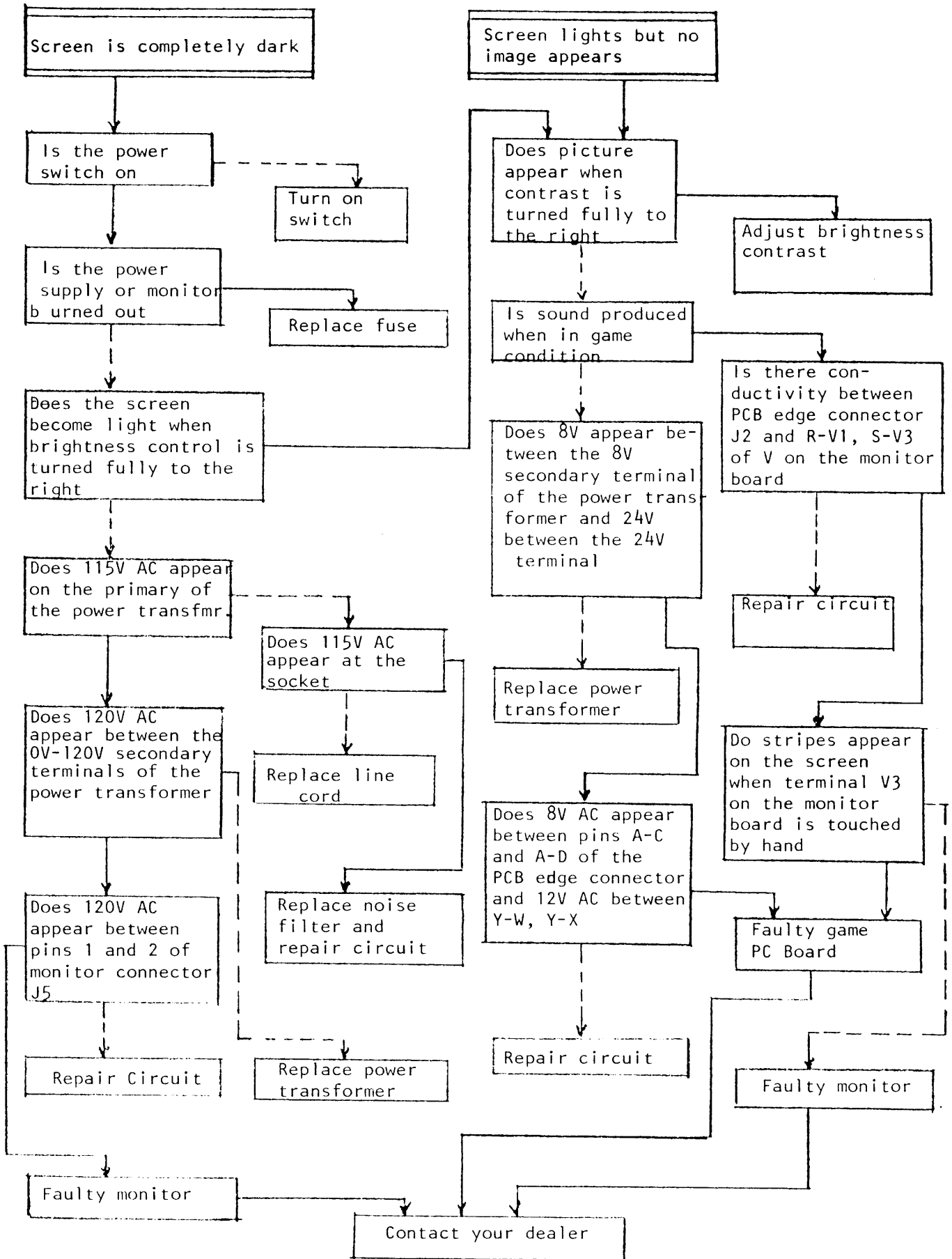





**Gremlin Industries, Inc.**  
San Diego, California 92123

**PARTS  
LIST**

TITLE  
TOP ASSEMBLY GEE-BEE

725-0002  
DWG NO

SH 3  
OF 9

A  
REV

ITEM NO	PART NO	QTY PER ASSY					DESCRIPTION	REF DES
25	280-0005	10					CABLE TIE	
26	280-0010	6					NUT WIRE	
27	220-0008	1					COUNTER DIGITAL	
28	390-0011	1					LAMP FLOR 18"	
29	390-0012	1					LAMP FIX FLOR 18"	
30	420-0028	1					DECAL S/N	
31	420-0030	1					DECAL CAUTION 115V	
32	420-0038	2					DECAL IMPORTANT NOTICE	
33	420-0040	1					DECAL RECYCLE	
34	420-0041	1					DECAL S/N SMALL	
35	420-0060	1					DECAL TIP N TELL	
36	420-0071	1					INST UNCRATING.	
37	420-0208	1					WRAP AROUND SIDE	
38	420-0209	1					TOP COVER.	
39	420-0124	4					CORNER STRIP.	
40	420-0198	1					SHADOW MASK.	
41	420-0199	1					MANUAL GEE-BEE	
42	420-0200	1					DECAL CARTON GEE-BEE	
43	420-0201	1					GRAPHIC SIDE LEFT	
44	420-0202	1					GRAPHIC SIDE RIGHT	
45	420-0207	1					DECAL SCORE	
46	420-0158	1					MANUAL W.G. 23 INCH	
47	250-0326	1					PLATE MTG XFMR.	
48								
49	807-0009	1					ASSY JUNCTION BOX.	

Gremlin Industries, Inc. San Diego, California 92123		PARTS LIST		TITLE TOP ASSEMBLY GEE - B&E		725-0002 DWG NO		SH 4 OF 9		A REV		
ITEM NO	PART NO	QTY PER ASSY					DESCRIPTION	REF DES				
50	825-0007	1					ASSEMBLY XFMR.					
51	825-0001	1					VIEDO LOGIC					
52	825-0002	1					CONTROL PNL					
53	825-0003	1					HARNESS CONTROL PNL					
54	825-0004	1					HARNESS SPEAKER					
55	825-0005	1					HARNESS COIN MECH					
56	825-0006	1					HARNESS, MAIN					
57	420-0204	1					COIN DECAL					
58	420-0205	1					PLAYER DECAL					
59		4					SCR. 1/4-20 x 1/2 HEX HD					
60		3					SCREW # 6 x 1/2 PAN HD XREC SHT MTL.					
61		6					SCREW # 10 x 1/2 PAN HD XREC SHT MTL.					
62		4					SCR. 10-24 x 1 PAN HD XREC					
63		4					SCR. 8-32 x 1/2 RND. HD XREC BLK OXIDE					
64		8					SCR. 10-24 x 1 1/2 CARRIAGE					
65		3					SCREW # 6 x 3/8 PAN HD XREC. SHT MTL.					
66		2					SCR. 6-32 x 3/8 PAN HD XREC					
67		4					SCREW # 10 x 3/4 PAN HD XREC SHT MTL.					
68		2					SCR 10-24 x 1 CARRIAGE					
69		2					SCR. 1/4-20 x 3/8 PAN HD XREC.					
70		2					SCR. 10-24 x 1/2 PAN HD XREC					
71		4					SCR 6-32 x 1/2 PAN HD XREC					
72		8					SCR 6-32 x 1/2 TRUSS HD TAMPER PROOF					
73		4					RIVET, POP 3/16 DIA. x 1/2					
74		4					NUT. HEY 1/4-20					





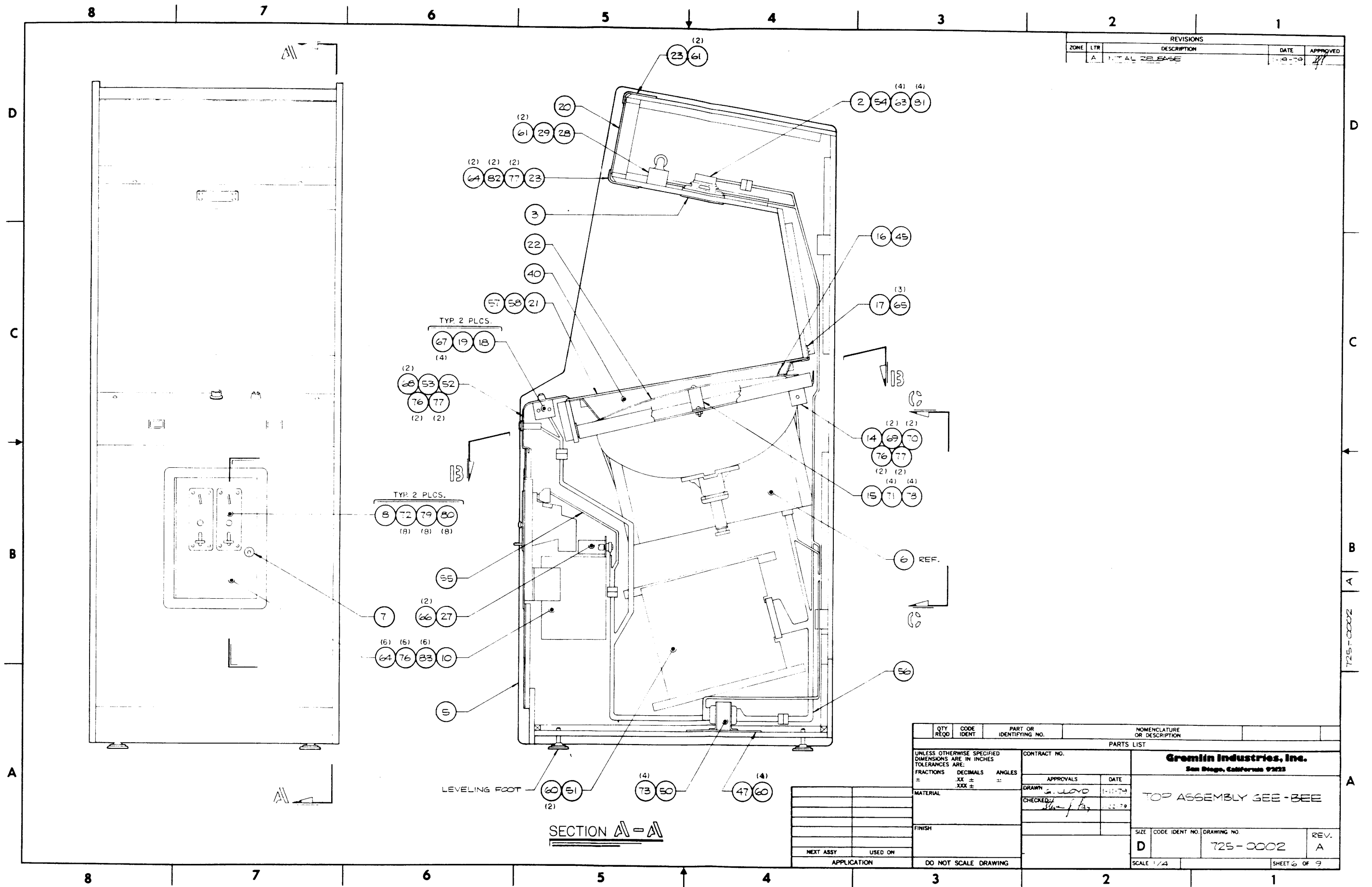

REVISIONS				
ZONE	LTR	DESCRIPTION	DATE	APPROVED
A		INITIAL RELEASE	11-9-79	[Signature]

TYP. 2 PLCS.  
67 19 18

TYP. 2 PLCS.  
8 72 79 80

SECTION A-A

QTY REQD	CODE IDENT	PART OR IDENTIFYING NO.	NOMENCLATURE OR DESCRIPTION
PARTS LIST			
UNLESS OTHERWISE SPECIFIED DIMENSIONS ARE IN INCHES TOLERANCES ARE:		CONTRACT NO.	
FRACTIONS	DECIMALS	ANGLES	
±	.XX ±	±	
	.XXX ±		
MATERIAL		APPROVALS	
		DRAWN <i>J. LLOYD</i> 11-11-79	
		CHECKED <i>[Signature]</i> 11-22-79	
FINISH		DATE	
NEXT ASSY		SIZE	
USED ON		D	
APPLICATION		CODE IDENT NO. DRAWING NO.	
		725-0002	
		REV. A	
		SCALE 1/4	
		SHEET 6 OF 9	

725-0002

REVISIONS				
ZONE	LTR	DESCRIPTION	DATE	APPROVED
A		FINAL RELEASE	1-19-79	[Signature]

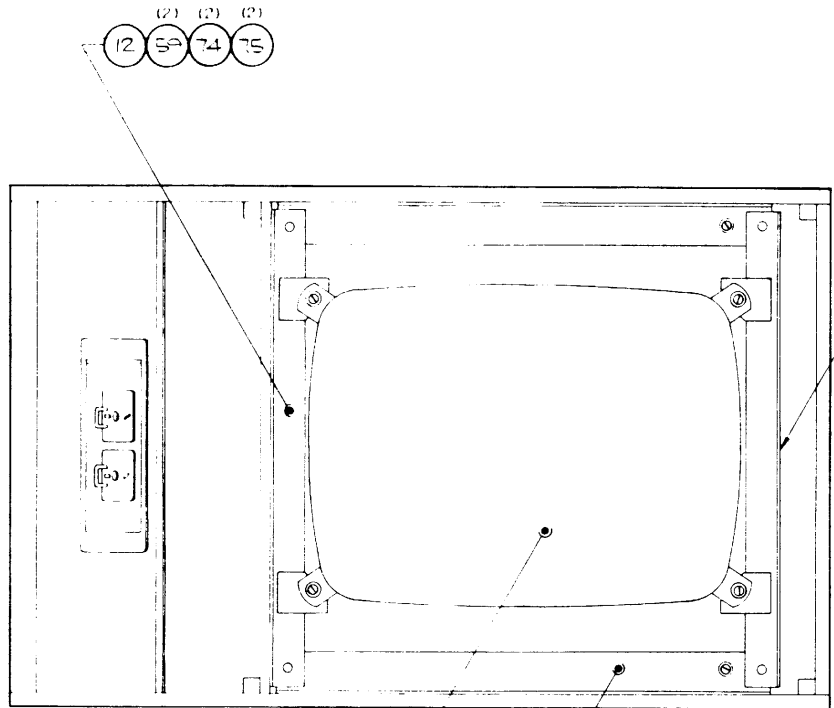

(12) (5) (74) (75)  
 (13) (39) (74) (75)  
 (62) (76) (77) (6)  
 (11) TYP 2 PLCS.

SECTION 13-13

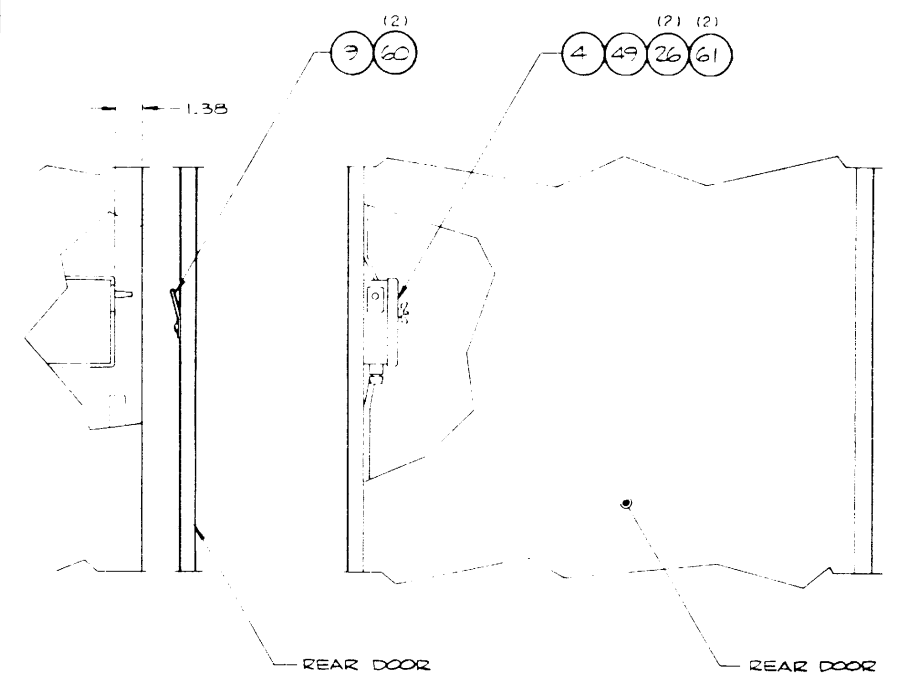

VIEW C-C

QTY REQD	CODE IDENT	PART OR IDENTIFYING NO.	NOMENCLATURE OR DESCRIPTION	
PARTS LIST				
UNLESS OTHERWISE SPECIFIED DIMENSIONS ARE IN INCHES TOLERANCES ARE:		CONTRACT NO.		
FRACTIONS	DECIMALS	ANGLES	APPROVALS	DATE
±	XX ±	±	Ge. LLOYD	1-16-79
MATERIAL		CHECKED [Signature] 1-22-79		
FINISH		SIZE CODE IDENT NO. DRAWING NO.		
NEXT ASSY USED ON APPLICATION		D 725-0002 A		
DO NOT SCALE DRAWING		SCALE 1/4 SHEET 7 OF 9		

**Gremlin Industries, Inc.**  
 San Diego, California 92123

TOP ASSEMBLY GEE-BEE

725-0002

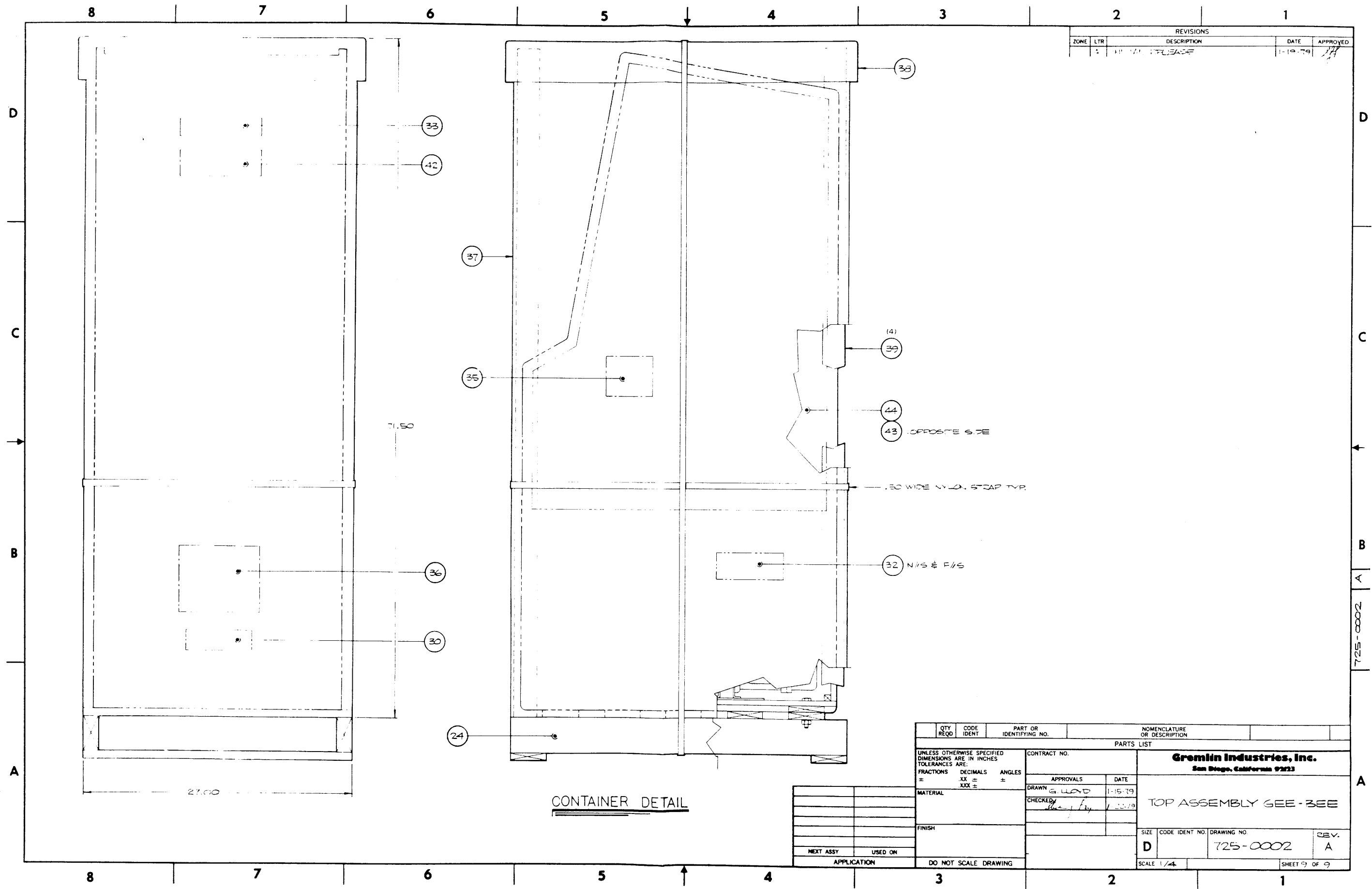

REVISIONS				
ZONE	LTR	DESCRIPTION	DATE	APPROVED
1		INITIAL RELEASE	1-18-79	

QTY REQD	CODE IDENT	PART OR IDENTIFYING NO.	NOMENCLATURE OR DESCRIPTION
PARTS LIST			
UNLESS OTHERWISE SPECIFIED DIMENSIONS ARE IN INCHES TOLERANCES ARE:		CONTRACT NO.	
FRACTIONS	DECIMALS	ANGLES	
±	.XX ±	±	
	.XXX ±		
MATERIAL		APPROVALS	
		DRAWN	DATE
		G. WARD	1-15-79
		CHECKED	
		<i>[Signature]</i>	1-22-79
FINISH		GREMLIN INDUSTRIES, INC. San Diego, California 92123	
		TOP ASSEMBLY GEE-3EE	
NEXT ASSY		SIZE	CODE IDENT NO
USED ON		D	725-0002
APPLICATION		DRAWING NO.	REV.
			A
DO NOT SCALE DRAWING		SCALE	SHEET 9 OF 9
		1/4	

725-0002

REVISIONS				
ZONE	LTR	DESCRIPTION	DATE	APPROVED
A		INITIAL RELEASE	1-19-79	<i>[Signature]</i>

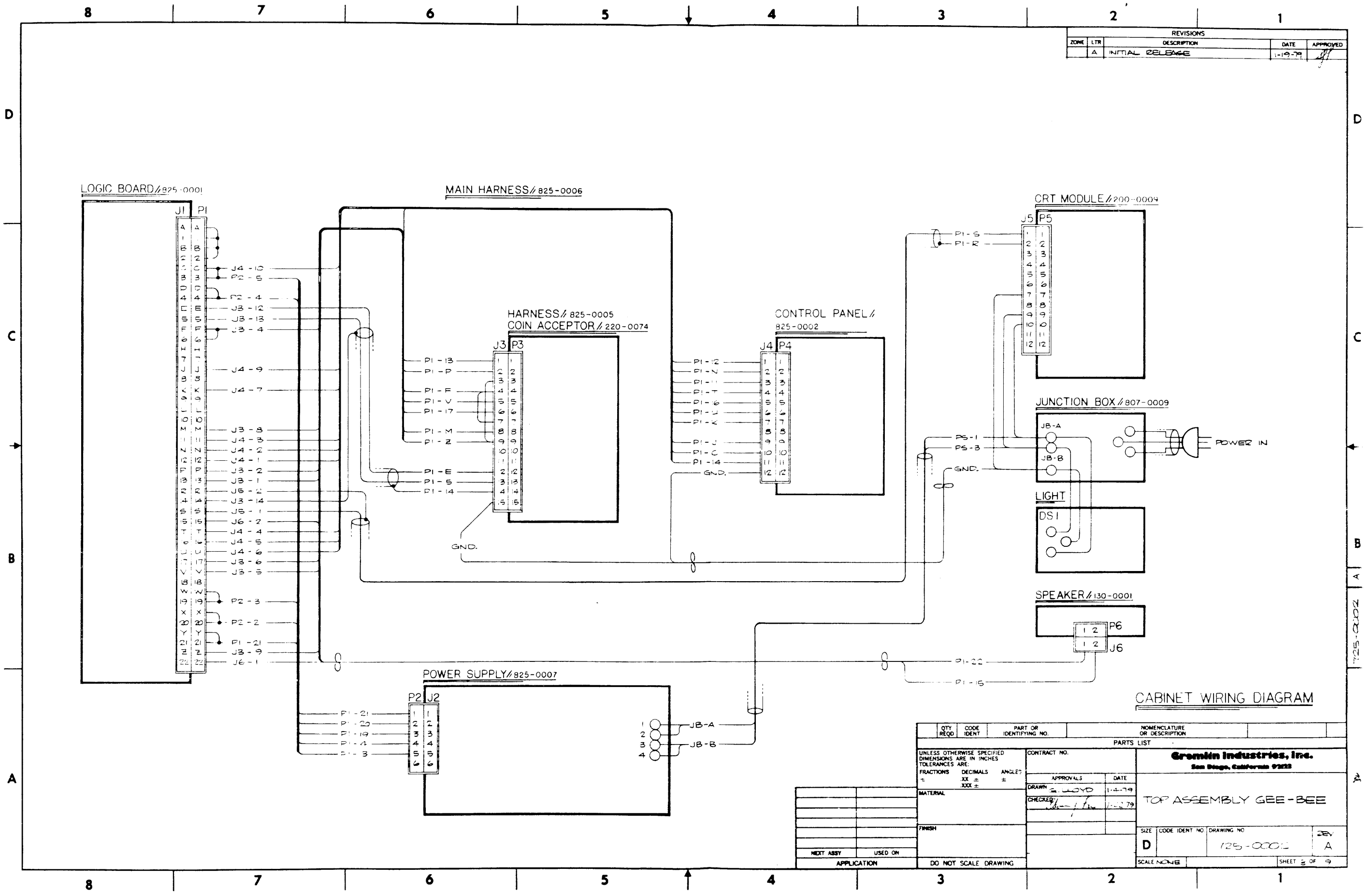

CABINET WIRING DIAGRAM

QTY REQD	CODE IDENT	PART OR IDENTIFYING NO.	NOMENCLATURE OR DESCRIPTION
PARTS LIST			
UNLESS OTHERWISE SPECIFIED DIMENSIONS ARE IN INCHES TOLERANCES ARE:		CONTRACT NO.	
FRACTIONS	DECIMALS	ANGLE'S	
±	.XX ±	±	
	.XXX ±		
MATERIAL		APPROVALS	DATE
		<i>[Signature]</i>	1-4-79
FINISH		CHECKED	DATE
		<i>[Signature]</i>	1-22-79
NEXT ASSY		USED ON	
APPLICATION		DO NOT SCALE DRAWING	
Gromin Industries, Inc. San Diego, California 92123			TOP ASSEMBLY GEE-BEE
SIZE	CODE IDENT NO.	DRAWING NO.	REV
D		125-0001	A
SCALE	NONE	SHEET 2 OF 9	

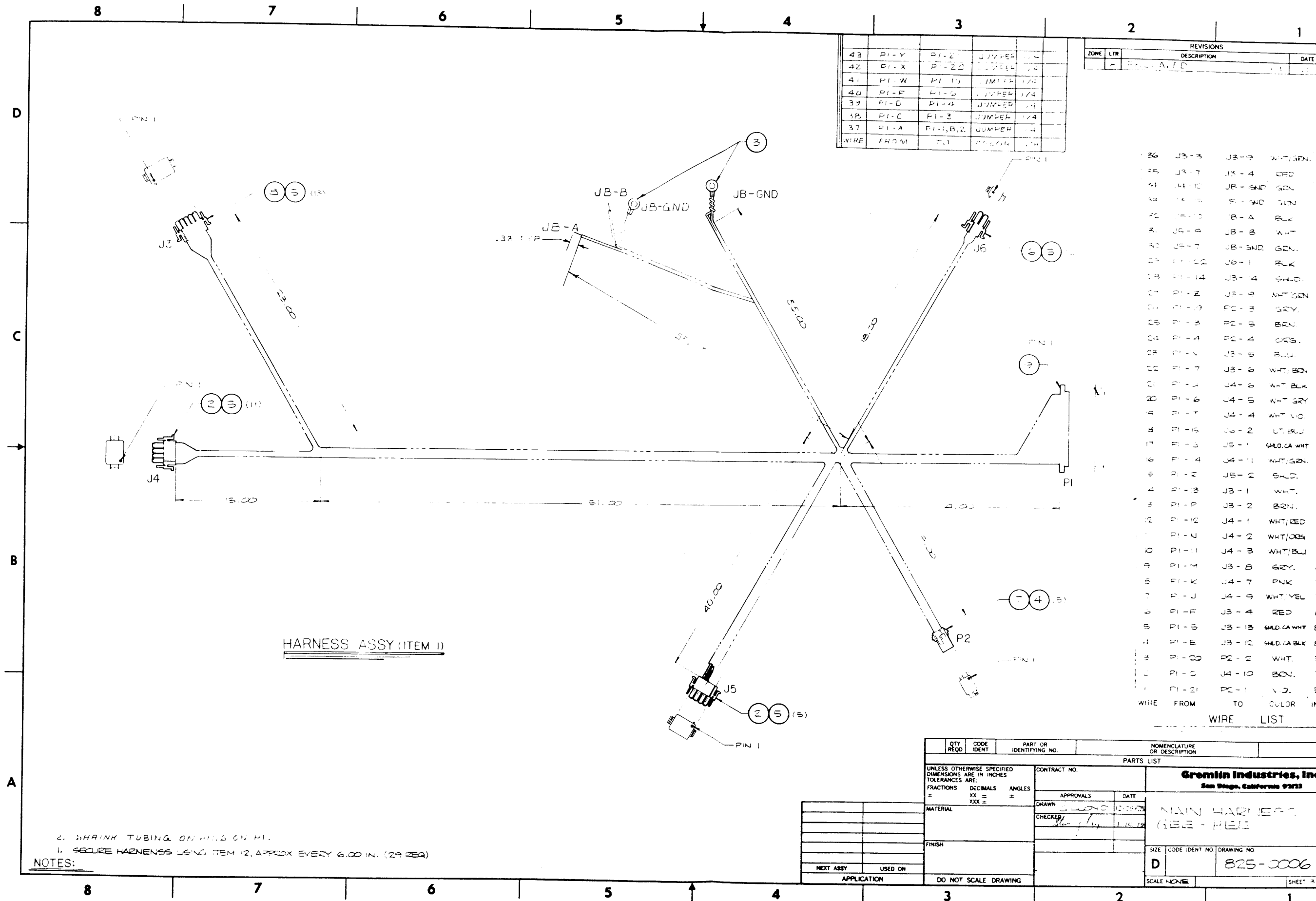

43	PI-Y	PI-21	JUMPER	1/4
42	PI-X	PI-20	JUMPER	1/4
41	PI-W	PI-19	JUMPER	1/4
40	PI-F	PI-6	JUMPER	1/4
39	PI-D	PI-4	JUMPER	1/4
38	PI-C	PI-3	JUMPER	1/4
37	PI-A	PI-1,B,2	JUMPER	1/4
	WIRE FROM	TO	QUANTITY	IN

REVISIONS		
ZONE	LTR	DESCRIPTION

QTY	REQD	CODE IDENT	PART OR IDENTIFYING NO.	NOMENCLATURE OR DESCRIPTION
26			J3-3	J3-3 WHT/GRN
25			J3-7	J3-4 RED
24			J4-10	J3-GND GRN
23			J4-15	J3-GND GRN
22			J3-10	J3-A BLK
21			J3-9	J3-B WHT
20			J3-7	J3-GND GRN
19			J4-22	J6-1 BLK
18			PI-14	J3-14 SHLD.
17			PI-2	J3-9 WHT/GRN
16			PI-9	PC-3 GRY.
15			PI-3	P2-5 BRN
14			PI-4	P2-4 ORG.
13			PI-5	J3-5 BLU.
12			PI-7	J3-6 WHT/BLU
11			PI-8	J4-6 WHT/BLK
10			PI-6	J4-5 WHT/GRY
9			PI-7	J4-4 WHT/IO
8			PI-5	J3-2 LT.BLU
7			PI-3	J3-1 SHLD.CA WHT
6			PI-4	J4-11 WHT/GRN
5			PI-2	J5-2 SHLD.
4			PI-3	J3-1 WHT.
3			PI-P	J3-2 BRN.
2			PI-10	J4-1 WHT/RED
1			PI-N	J4-2 WHT/ORG
10			PI-11	J4-3 WHT/BLU
9			PI-M	J3-8 GRY.
8			PI-K	J4-7 PNK
7			PI-J	J4-9 WHT/YEL
6			PI-F	J3-4 RED
5			PI-5	J3-13 SHLD.CA WHT
4			PI-E	J3-12 SHLD.CA BLK
3			PI-20	P2-2 WHT.
2			PI-9	J4-10 BRN.
1			PI-21	PC-1 V.D.

WIRE FROM TO COLOR IN

WIRE LIST

QTY REQD	CODE IDENT	PART OR IDENTIFYING NO.	NOMENCLATURE OR DESCRIPTION
PARTS LIST			
UNLESS OTHERWISE SPECIFIED DIMENSIONS ARE IN INCHES TOLERANCES ARE FRACTIONS DECIMALS ANGLES ± .XX ± .XXX ±			
MATERIAL		CONTRACT NO.	
FINISH		APPROVALS DATE	
NEXT ASSY USED ON APPLICATION		DRAWN CHECKED	
DO NOT SCALE DRAWING		DATE	

**Gremlin Industries, Inc**  
San Diego, California 92123

MAIN HARNESS (REV. 11/82)

SIZE CODE IDENT NO. DRAWING NO.  
D 825-0006

SCALE NONE SHEET 2

NOTES:  
2. SHRINK TUBING ON PINS ON P1.  
1. SECURE HARNESS USING ITEM 12, APPROX EVERY 6.00 IN. (29 REQ)



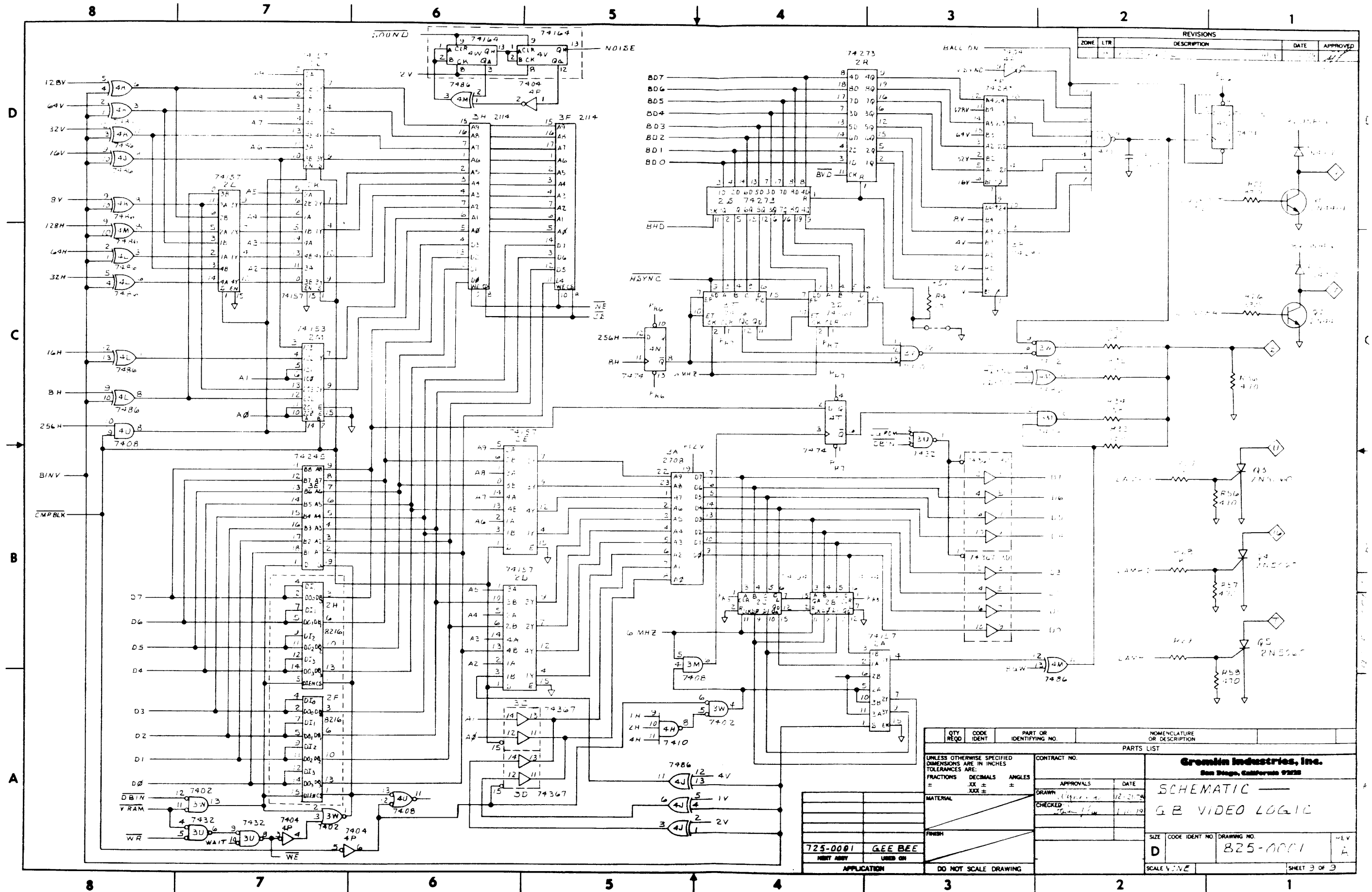

REVISIONS				
ZONE	LTR	DESCRIPTION	DATE	APPROVED

QTY REQD	CODE IDENT	PART OR IDENTIFYING NO.	NOMENCLATURE OR DESCRIPTION

PARTS LIST	
UNLESS OTHERWISE SPECIFIED DIMENSIONS ARE IN INCHES TOLERANCES ARE:	CONTRACT NO.
FRACTIONS DECIMALS ANGLES	APPROVALS DATE
= XX ± ±	DRAWN 12-21-74
XXX ± ±	CHECKED 1-10-75
MATERIAL	
FRESH	
725-0001 GEE BEE	
NIET ASSY USED ON	
APPLICATION	DO NOT SCALE DRAWING

SIZE	CODE IDENT NO	DRAWING NO.	REV
D		825-0001	A
SCALE 1/2" = 1"			
			SHEET 3 OF 3

**Gremm Industries, Inc.**  
San Diego, California 92128

**SCHEMATIC**  
**GB VIDEO LOGIC**

825-0001  
SHEET 3 OF 3



REVISIONS			
ZONE	LYR	DESCRIPTION	DATE
4		RELEASED	J.E. BEE

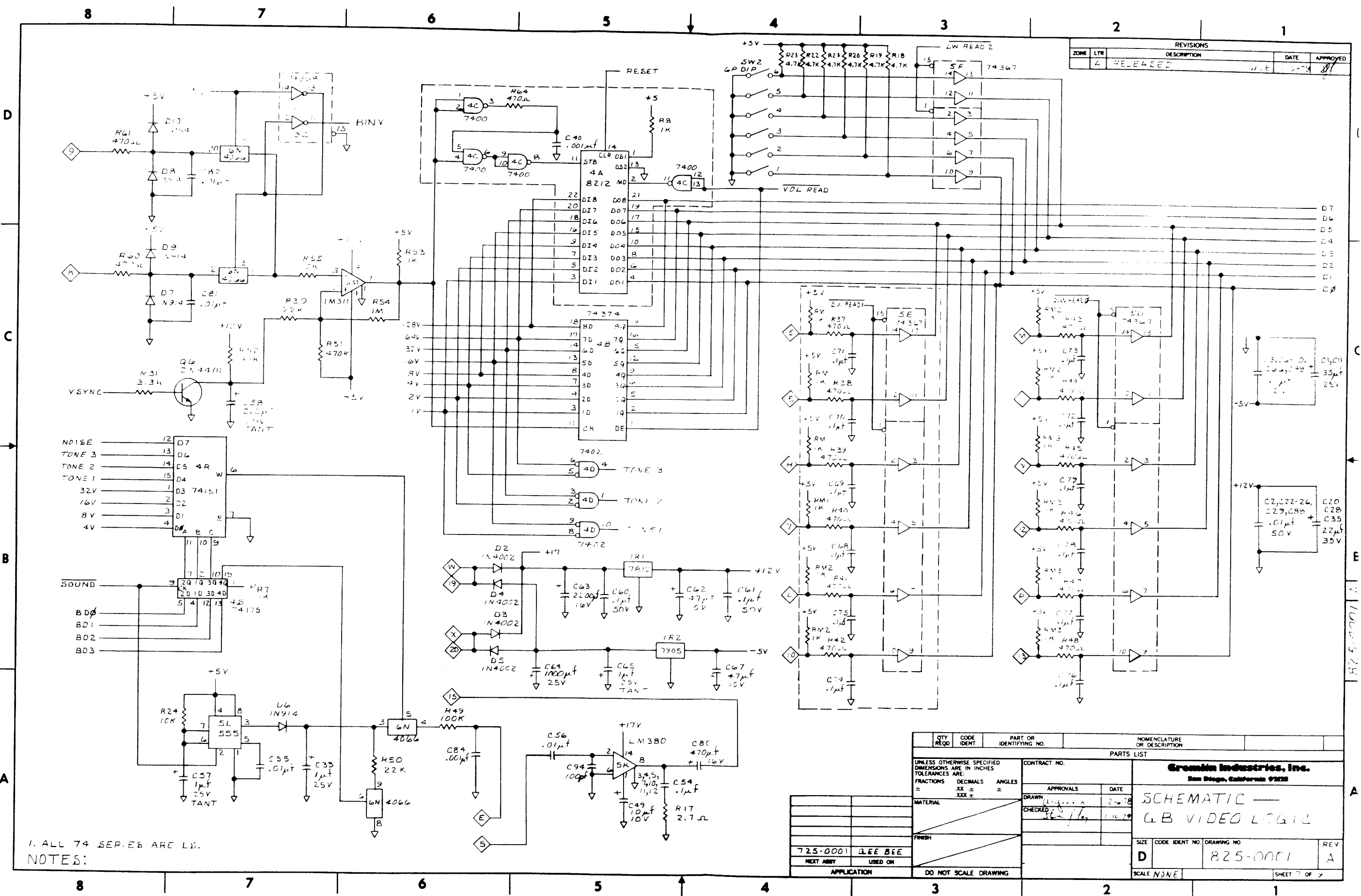

1. ALL 74 SERIES ARE LSI.  
 NOTES:

QTY REQD	CODE IDENT	PART OR IDENTIFYING NO.	NOMENCLATURE OR DESCRIPTION
PARTS LIST			
UNLESS OTHERWISE SPECIFIED DIMENSIONS ARE IN INCHES TOLERANCES ARE:		CONTRACT NO.	
FRACTIONS	DECIMALS	ANGLES	
=	XX ±	XXX ±	
MATERIAL		APPROVALS	DATE
FINISH		CHECKED	
NEXT ASSY USED ON		DRAWN BY	
APPLICATION		DATE	
DO NOT SCALE DRAWING		SCALE NONE	

**Crombin Industries, Inc.**  
 San Diego, California 92128

SCHEMATIC —  
 LB VIDEO LOGIC

SIZE	CODE IDENT NO.	DRAWING NO.	REV
D		825-0001	A

SHEET 7 OF 7

REVISIONS				
ZONE	LTR	DESCRIPTION	DATE	APPROVED
			JUL 8 1-10-79	

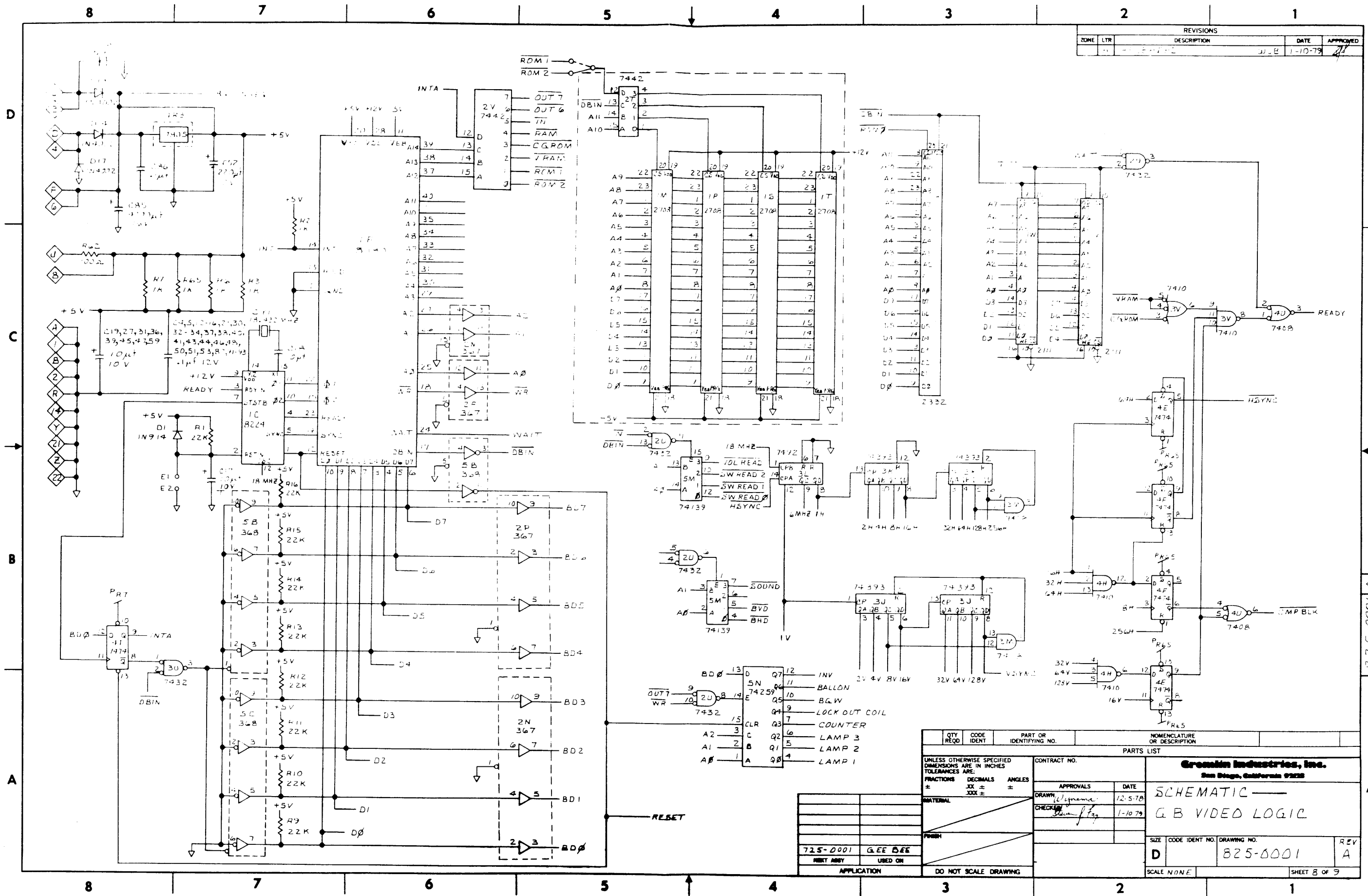

BD0	13	D	Q7	12	INV
		SN	Q6	11	BALLON
		E	Q5	10	BQW
			Q4	9	LOCK OUT COIL
			Q3	7	COUNTER
		C	Q2	6	LAMP 3
A2	3		Q1	5	LAMP 2
A1	2	B	Q0	4	LAMP 1
A0	1	A			

QTY REQD	CODE IDENT	PART OR IDENTIFYING NO.	NOMENCLATURE OR DESCRIPTION
			UNLESS OTHERWISE SPECIFIED DIMENSIONS ARE IN INCHES TOLERANCES ARE:
			FRACTIONS DECIMALS ANGLES
			± .005 ± .001 ± .001 ±
			MATERIAL
			FINISH
			APPLICATION
			DO NOT SCALE DRAWING

CONTRACT NO.		PARTS LIST	
APPROVALS	DATE	Green Industries, Inc.	
DRAWN <i>W. J. ...</i>	12-5-78	San Diego, California 92128	
CHECKED <i>...</i>	1-10-79	SCHEMATIC	
		G.B. VIDED LOGIC	
SIZE	CODE IDENT NO.	DRAWING NO.	REV
D		825-0001	A
SCALE	NONE	SHEET 8 OF 9	

825-0001 A

Graham Industries, Inc. San Diego, California 92123		PARTS LIST		TITLE ASSY VIDEO LOGIC G. B		825-0001 DWG NO		SH 2 OF 9		A REV	
ITEM NO	PART NO	QTY PER ASSY					DESCRIPTION	REF DES			
1	150-0001	3					CAP E 22 $\mu$ f 35V	C20, C28, C35			
2	150-0004	9					CAP E 10 $\mu$ f 10V	C19, C27, C31, C36, C39, C45, C47, C49, C59			
3	150-0005	1					CAP E 4700 $\mu$ f 16V	C85			
4	150-0008	1					CAP E 2200 $\mu$ f 16V	C63			
5	150-0012	2					CAP E 47 $\mu$ f 10V	C62, C67			
6	150-0017	2					CAP E 35 $\mu$ f 25V	C1, C11			
7	150-0031	1					CAP E 470 $\mu$ f 16V	C80			
8	150-0032	1					CAP E 220 $\mu$ f 10V	C52			
9	150-0033	1					CAP E 1000 $\mu$ f 25V	C64			
10	151-0002	1					CAP CER 100 pf 50V	C94			
11	151-0008	1					CAP CER .001 $\mu$ f 50V	C84			
12	151-0011	13					CAP CER .01 $\mu$ f 50V	C22, 26, 29, 42, 55, 56, 81, 82, 88			
13	151-0012	2					CAP CER .1 $\mu$ f 50V	C60, C61			
14	151-0013	1					CAP CER 10 pf 50V	C18			
15	151-0017	43					CAP CER .1 $\mu$ f 12V	C3-C9, C10, C12-C16, C21, C30, C32-C34, C37, C38, C40, C41, C43, C44, C46, C48, C50, C51, C53, C54, C66, C72, C73, C76-C79, C86, C87, C89, C91-C93			
16	153-0001	1					CAP TANT 10 $\mu$ f 10V	C17			
17	153-0002	3					CAP TANT 1 $\mu$ f 25V	C33, C57, C65			
18	153-0003	1					CAP TANT 2.2 $\mu$ f 25V	C58			

Greenlin Industries, Inc.  
San Diego, California 92122

PARTS  
LIST

TITLE  
ASSY VIDEO LOGIC  
G.B.

825-0001  
DWG NO

SH 3  
OF 9

A  
REV

ITEM NO	PART NO	QTY PER ASSY					DESCRIPTION	REF DES
19	170-0157	1					PCB VID LOG G.B.	
20	211-0004	2					CONN PIN TEST PT	E1, E2
21	213-0001	6					SKT 24 PIN DUAL INLN	XIK, X3A, XIM, XIP, XIS, XIT
22	213-0005	1					SKT 40 PIN DUAL INLN	XIF
23	230-0023	1					XTAL 18.432 MHZ	CY
24	313-0002	1					IC LM311C	6M
25	313-0003	1					IC 7805	1R3
26	313-0006	1					IC LM380	5K
27	313-0014	1					IC 7812	1R1
28	313-0023	1					IC 7905C	1R2
29	314-0001	1					IC NE555	5L
30	314-0019	1					IC 74LS04	4P
31	314-0058	2					IC 74LS08	3M 4U
32	314-0059	2					IC 74LS10	3V 4H
33	314-0061	2					IC 74LS42	2V, 2T
34	314-0062	4					IC 74LS74	4E, 4F, 4N, 4T
35	314-0064	1					IC 74LS153	2M
36	314-0067	1					IC 74LS30	3N
37	314-0068	2					IC 74LS32	2U, 3U
38	314-0070	4					IC 74LS86	4J, 4K, 4L, 4M
39	314-0071	1					IC 74LS151	4R
40	314-0073	1					IC 74LS175	4S

Grosslin Industries, Inc. San Diego, California 92122		PARTS LIST		TITLE ASSY VIDEO LOGIC G.B.		825-0001 DWG NO		SH 4 OF 9		A REV	
ITEM NO	PART NO	QTY PER ASSY				DESCRIPTION	REF DES				
41	314-0075	2				IC 74LS393	3J,3K				
42	314-0076	6				IC 74LS157	2A,2D,2E,2J,2K,2L				
43	314-0078	2				IC 74LS02	3W 4D				
44	314-0087	1				IC 74LS139	5M				
45	314-0093	1				IC 74LS374	4B				
46	314-0094	1				IC 74LS259	5N				
47	314-0095	1				IC 8224	1C				
48	314-0096	1				IC 74LS92	3L				
49	314-0097	2				IC 74LS161	3S,3T				
50	314-0098	2				IC 74LS194	2B,2C				
51	314-0099	1				IC 74LS245	3E				
52	314-0100	2				IC 74LS273	2R,2S				
53	314-0101	2				IC 74LS283	3P 3R				
54	314-0102	6				IC 74LS367	2N,2P,3C,3D,5D,5F				
55	314-0103	2				IC 74LS368	5B,5C				
56	315-0014	1				IC 8080	1F				
57	315-0018	2				IC 2111	1V,1W				
58	315-0019	1				IC 2708	3A				
59	315-0045	1				IC CD4066	6N				
60	315-0046	2				IC 2114 / 2114L RAM	3F,3H				
61	470-0102	18				RES 1K OHM 1/4W 5%	R2-4,6-8,27-29,35,53,65				
62	470-0103	2				RES 10K OHM 1/4W 5%	R24,R55				
63	470-0104	1				RES 100K OHM 1/4W 5%	R49				
64	470-0223	11				RES 2.2K OHM 1/4W 5%	R1,R9-R16,R30 R50				

Greenix Industries, Inc.  
San Diego, California 92122

PARTS  
LIST

TITLE  
ASSY VIDEO LOGIC  
G.B.

825-0001  
DWG NO

SH 5  
OF 9

A  
REV

ITEM NO	PART NO	QTY PER ASSY					DESCRIPTION	REF DES
65	470-02R7	1					RES 2.7 OHM 1/4W 5%	R17
66	470-0332	1					RES 3.3K OHM 1/4W 5%	R31
67	470-0331	2					RES 330 OHM 1/4W 5%	R25, R26
68	470-0152	2					RES 1.5K OHM 1/4W 5%	R33, R34
69	470-0471	12					RES 470 OHM 1/4W 5%	R43-R48, R36, R56-R58, R60, R61
70	470-0472	6					RES 4.7K OHM 1/4W 5%	R18 - R23
71	470-0474	1					RES 470K OHM 1/4W 5%	R51
72	470-0912	1					RES 9.1K OHM 1/4W 5%	R52
73	481-0001	10					DIODE 1N4002	D2-D5, D11-D14, D16, D17
74	481-0006	6					DIODE 1N914 / 1N4148	D1, D6-D10
75	482-0009	3					XSTR 2N5060	Q3-Q5
76	482-0014	3					XSTR 2N4401	Q1 Q2 Q6
77	510-0043	1					SWITCH 6 POS DIP	SW 2
78	530-0008	1					HEAT SINK	
79	470-0105	1					RES 1M OHM 1/4W 5%	R54
80	470-0101	1					RES 100 OHM 1/4W 5%	R62
81	470-0682	1					RES 680 OHM 1/4W 5%	R32
82	316-0137	1					IC PROM 2332 G.B.	1K