

# MIDWAYS



## Parts and Operating Manual



No. 514 MINI

No. 510 COCKTAIL

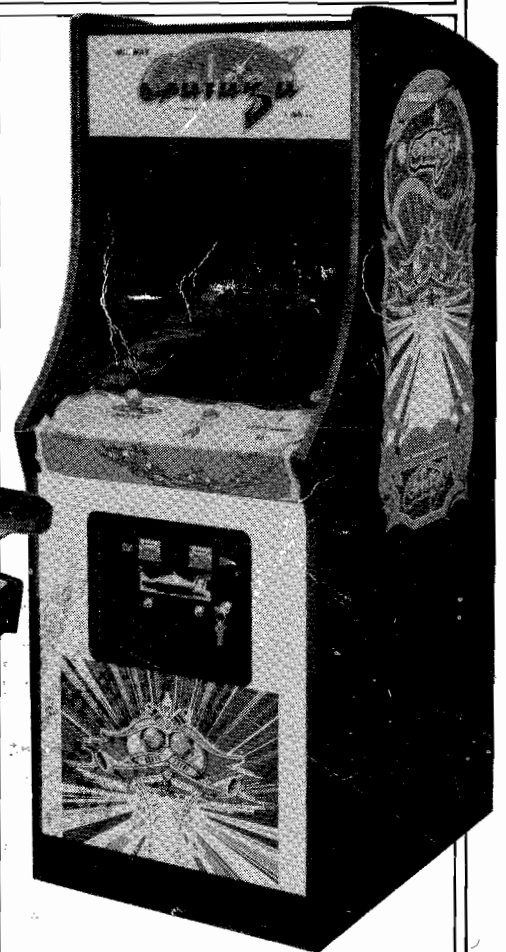
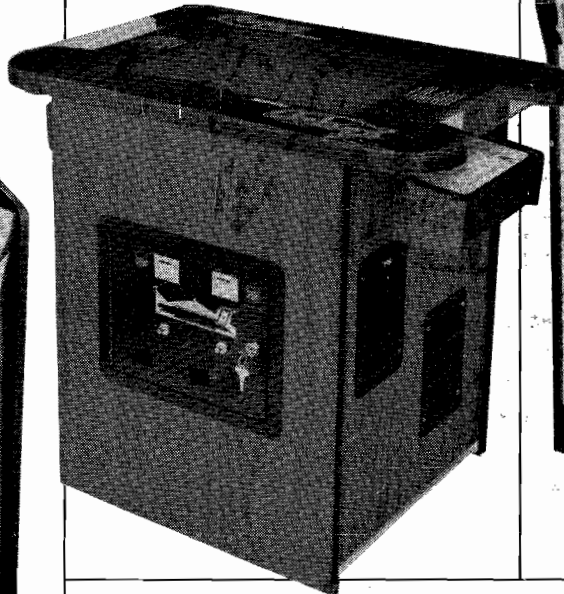

No. 508 UPRIGHT



**MIDWAY MFG. CO.**

A BALLY COMPANY

10750 W. GRAND AVENUE  
FRANKLIN PARK, ILLINOIS 60131  
USA

Phone: (312) 451-1360 Cable Address: MIDCO Telex No.: 72-1596

**WARNING**

**THIS GAME MUST BE GROUNDED. FAILURE TO DO SO MAY RESULT IN DESTRUCTION TO ELECTRONIC COMPONENTS.**

**WARNING:** This equipment Generates, Uses and can Radiate Radio Frequency Energy and if not installed and used in accordance with the Instructions Manual, may cause interference to Radio Communications. As temporarily permitted by Regulation it has not been tested for compliance to Subpart J or Part 15 of FCC Rules, which are designed to provide reasonable protection against such interference. Operation of this equipment in a Residential Area is likely to cause interference in which case the user at his own expense will be required to take whatever measures may be required to correct the interference.

**ELECTRICAL BULLETIN:** FOR ALL APPARATUS COVERED BY THE CANADIAN STANDARDS ASSOCIATION (CSA) STANDARD C22.2 NO. 1, WHICH EMPLOYS A SUPPLY CORD TERMINATED WITH A POLARIZED 2-PRONG ATTACHMENT PLUG.

**CAUTION:** TO PREVENT ELECTRIC SHOCK DO NOT USE THIS (POLARIZED) PLUG WITH AN EXTENSION CORD, RECEPTACLE OR OTHER OUTLET UNLESS THE BLADES CAN BE FULLY INSERTED TO PREVENT BLADE EXPOSURE.

**ATTENTION:** POUR PREVENIR CHOCS ELECTRIQUES NE PAS UTILISER CETTE FICHE POLARISEE AVEC UN PROLONGATEUR. UNE PRISE DE COURANT OU UNE AUTRE SORTIE DE COURANT, SAUF SI LES LAMES PEUVENT ETRE INSEREES A FOND SANS EN LAISSER AUCUNE PARTIE A DECOUVERT.



**MIDWAY MFG. CO.**  
A BALLY COMPANY

*Invites You To Use*

**OUR TOLL FREE NUMBERS FOR  
SERVICE INFORMATION CONCERNING THIS GAME, OR ANY  
OTHER MIDWAY GAME YOU NOW HAVE ON LOCATION.**

**CALL US FOR PROMPT, COURTEOUS  
ANSWERS TO YOUR PROBLEMS.**

**Continental U. S. 800-323-7182**

**Illinois Only 1-800-942-0497**

COPYRIGHT 1981 © BY MIDWAY MFG. CO. ALL RIGHTS RESERVED.

NO PART OF THIS PUBLICATION MAY BE REPRODUCED BY ANY MECHANICAL, PHOTOGRAPHIC, OR ELECTRONIC PROCESS, OR IN THE FORM OF A PHONOGRAPHIC RECORDING, NOR MAY IT BE TRANSMITTED, OR OTHERWISE COPIED FOR PUBLIC OR PRIVATE USE, WITHOUT PERMISSION FROM THE PUBLISHER.

FOR PERMISSION REQUESTS, WRITE: MIDWAY MFG. CO., 10750 W. GRAND AVE., FRANKLIN PARK, IL 60131

Printed In U.S.A.

## TABLE OF CONTENTS

DESCRIPTION	PAGE
<b>I. Introduction</b> .....	1-1
<b>II. Location and Setup</b> .....	2-1
Inspection .....	2-1
Installation.....	2-1
Self-Test.....	2-3
Game Volume Adjustment Control .....	2-3
Option Switch Settings .....	2-4
Eliminating the Rapid (Automatic) Fire Feature .....	2-4
Game Operation .....	2-6
Self-Test Mode .....	2-6
Attract Mode.....	2-7
Ready-to-Play Mode .....	2-7
Play Mode .....	2-7
Two Player Operation .....	2-9
<b>III. Maintenance and Repair</b> .....	3-1
Cleaning.....	3-1
Fuse Replacement .....	3-1
Opening the Control Panel .....	3-1
Removal of Main-Display Glass and T.V. Bezel .....	3-2
T.V. Monitor Replacement .....	3-3
Printed Circuit Board Replacement.....	3-5
Opening the Attraction Panel .....	3-5
Coin Door Maintenance .....	3-7
<b>IV. Illustrated Parts Breakdown</b> .....	
Galaga Control Assembly — All Versions .....	4-1
Galaga Control Assembly — All Versions — Parts List .....	4-1
Front Door Assembly — U.S.A. 25¢ .....	4-2
Front Door Assembly — U.S.A. 25¢ — Parts List .....	4-3
Galaga — Card Rack Assy. w/Boards — All Versions .....	4-4
Galaga — Card Rack Assy. w/Boards — All Versions — Parts List .....	4-5
Galaga — Transformer Board Assy. — Parts List .....	4-5
No. 508 — Galaga Upright — Front .....	4-6
No. 508 — Galaga Upright — Front — Parts List .....	4-7
No. 508 — Galaga Upright — Rear Access.....	4-8
No. 508 — Galaga Upright — Rear Access — Parts List .....	4-9
No. 508 — Galaga Upright — Header Fluorescent Fixture Assy.....	4-10
No. 508 — Galaga Upright — Header Fluorescent Fixture Assy. — Parts List .....	4-11
No. 514 — Galaga Mini-Front .....	4-12
No. 514 — Galaga Mini-Front — Parts List.....	4-13
No. 514 — Galaga Mini — Rear Access.....	4-14
No. 514 — Galaga Mini — Rear Access — Parts List .....	4-15
No. 510 — Galaga Cocktail — Front.....	4-16
No. 510 — Galaga Cocktail — Front — Parts List .....	4-17
No. 510 — Galaga Cocktail — Interior Access .....	4-18
No. 510 — Galaga Cocktail — Interior Access — Parts List .....	4-19

## TABLE OF CONTENTS (cont'd)

<b>V. Technical Troubleshooting</b>	5-1
Introduction	5-1
General Suggestions	5-1
Harness Component Troubleshooting	5-1
Transformer and Line Voltage Problems	5-2
A Glossary of Microprocessor Terms	5-3
Introduction to the Z-80 CPU	5-3
General Purpose Registers	5-4
Arithmetic and Logic Unit (ALU)	5-4
Instruction Register and CPU Control	5-4
Z-80 CPU Pin Description	5-4
Basic Logic and Processor Books	5-6
<b>VI. T.V. Monitor Manual</b>	6-1
Introduction	6-1
Symptom Diagnosis	6-2
Guide to Schematic Symbols	6-3
Troubleshooting	6-5
Theory of Operation	6-6
Differences Between Monitors	6-8
Parts Interchangeability	6-9
<b>VII. Schematics and Wiring Diagrams</b>	
Wiring Diagram — Upright	7-1
Wiring Diagram — Mini	7-2
Wiring Diagram — Cocktail	7-3
Power Supply PCB — Component Layout	7-4
Power Supply PCB — Schematic	7-5
Video Board — Component Layout	7-6
Video Board — Schematic	7-7
CPU Board — Component Layout	7-8
CPU Board — Schematic	7-9
Rapid Fire PCB — Component Layout	7-10
Rapid Fire PCB — Schematic	7-11
Filter Board — Component Layout	7-12
Filter Board — Schematic	7-13

## TABLE OF FIGURES

FIGURE	PAGE
1 Location of serial number, interlock switch and ON/OFF switch	2-2
2 Location of volume control and option switch	2-3
3 Option switch settings	2-4
4a Self test display	2-6
4b Board location coordinates (self test display)	2-6
5 Opening Cocktail game	3-2
6 Removing monitor from Upright game	3-3
7 Removing monitor from Mini game	3-4
8 Removing monitor from Cocktail game	3-4
9 P.C.B. replacement	3-6
10 Opening the metal coin acceptor	3-8
11 Lubricating the metal coin acceptor	3-8
12 Changing the plastic coin acceptor for American or Canadian Quarters	3-9



# **I Introduction**

# Galaga

## IMPORTANT NOTE

DO NOT plug in your new game yet. Before you do anything to your game, we recommend that you read SECTIONS I and II of this manual completely. It will not take more than a few minutes and it may be very helpful.

## Introduction

GALAGA is a one or a two player game. There are three models: the "UPRIGHT", "MINI", and "COCKTAIL TABLE". When the two player mode is selected on the Upright or Mini model, the players take turns at the controls to fly their space fighter(s) through the game course. If you have purchased the Cocktail Table model of this game, the rules of play are the same. The only **difference** is that in the two player mode of the Cocktail Table game, the picture flips to face you when it's your turn.

When playing this game, you are the pilot of a space fighter stationed in space to defend your planet against the on-coming hordes of invaders. Your mission is to destroy as many of the enemy ships as possible.

These invaders arrive in convoys. They will attack you while swerving back and forth across the screen, dropping bombs all the while. Certain of the enemy ships can put out a tractor beam and capture your space fighter. That fighter changes color from white to red and stays with that particular enemy ship for the rest of the game. You can get it back by destroying the enemy ship that captured it while they are both attacking your current fighter. If you do this, the rescued ship changes color again from red back to white, and links up with your current fighter. This doubles your fire power.

As your skill level increases, the number of attackers coming at you at any one time and the speed with which the enemy ships attack is gradually increased, plus their attack patterns become more and more complex.

Bonus ships are awarded to you periodically throughout the game as you reach or pass certain preselected point values. Each enemy ship has an assigned point value.

## Major New Features

Two major new features of your GALAGA game are: 1) The player is given the chance to double his fire power at certain points throughout the game, and 2) The game has a rapid fire (automatic firing) option whereby the player just holds the FIRE button down and his space fighter continues to fire at the GALAGAS in bursts of two missiles each.

To double his fire power, the player must let one of his space fighters be captured by one of the GALAGA command ships and then rescue it. The GALAGA command ships **MUST BE SHOT TWICE** to destroy them. When shot once, they change color from green to blue. When shot again, they explode. The rescued fighter then links up with the one that rescued it and they now work as a team — both moving together and firing at the same time.

## Game Objective

The object of the game is to survive as long as possible while destroying as many attacking ships as you can. As you do this, each following convoy of attackers will be harder to destroy.

## **II Location and Setup**

# Location and Setup

## INSPECTION:

1. Remove the game from its shipping crate.
2. Inspect the entire outside of it for any signs of damage.
  - Any scratches?, dents?, cracks?
  - Any broken controls?
  - Any broken glass or plastic?
  - Just look it over closely and make a note of any signs of damage.
3. Remove the shipping cleats from the bottom of the cabinet.
4. Install the four levelers, one at each corner of the cabinet.
  - Level the cabinet.
5. Open the cabinet and inspect the inside of the game for any signs of damage.
  - Also check to make sure all plug-in connectors on the wire harness are firmly seated.

**NOTE:** ALL Connectors or plugs are keyed so they will only go together when all pins are properly lined up.

- Replug any connectors found unplugged. **DO NOT FORCE PLUGS ONTO CONNECTORS. DO NOT FORCE PLUGS TOGETHER.** If it won't go on easily, assuming the keys are lined up, it either does not belong there or is damaged.
  - Make sure all printed circuit boards (P.C.B.'s) are firmly seated in their connectors. These connectors are also keyed. The P.C.B.'s will only go into them one way without being damaged.
  - Note the location of the games serial number. See Figure 1.
  - Check all major subassemblies to be sure they are mounted securely.
    - Power supply.
    - Control panel(s).
    - T.V. monitor.
    - Other P.C.B.'s and/or P.C.B. rack, etc.
    - Power supply filter assembly.
    - Transformer board assembly.
6. Make a note of any problems that can't be easily corrected.
  7. Call your distributor and/or service man about your problem list.

## INSTALLATION:

### 1. Location requirements:

#### Power:

Domestic 110 V @ 60 Hz  
Foreign 200 V to 240 V @ 50 Hz

**Temperature:** 32° to 100°F (0° to 38°C)

**Humidity:** Not over 95% relative

#### Space required

Upright	25" x 33" (63 x 84 cm)
Mini	20" x 24" (50 x 60 cm)
Cocktail	32" x 22" (81 x 55 cm)

#### Game height:

Upright	70" (175 cm)
Mini	59" (148 cm)
Cocktail	29" (73 cm)

### 2. Voltage Selections:

Your game is designed to work properly on the line voltage where you are located. Check your line voltage with a meter to determine what its value is. Then check the power input wires to the main power supply transformer on your game to be sure they are connected to taps which correspond to your line voltage value.

If the power input wires to the main power supply transformer are not connected to taps which correspond to your local line voltage, move them to the proper taps.

If the line voltage in your area falls outside the upper or lower limits of the range of inputs covered by the main power supply transformer, **DO NOT PLUG YOUR GAME IN** until you have talked with your distributor and/or service man and obtained a solution to this problem. Otherwise you could damage your game.

### 3. Interlock and power ON/OFF switches. (See Figure 1.

- To help prevent the possibility of getting an electric shock while working inside the game cabinet, interlock switches have been installed at each cabinet access door (this **DOES NOT** include the coin door in the Upright and Mini models).

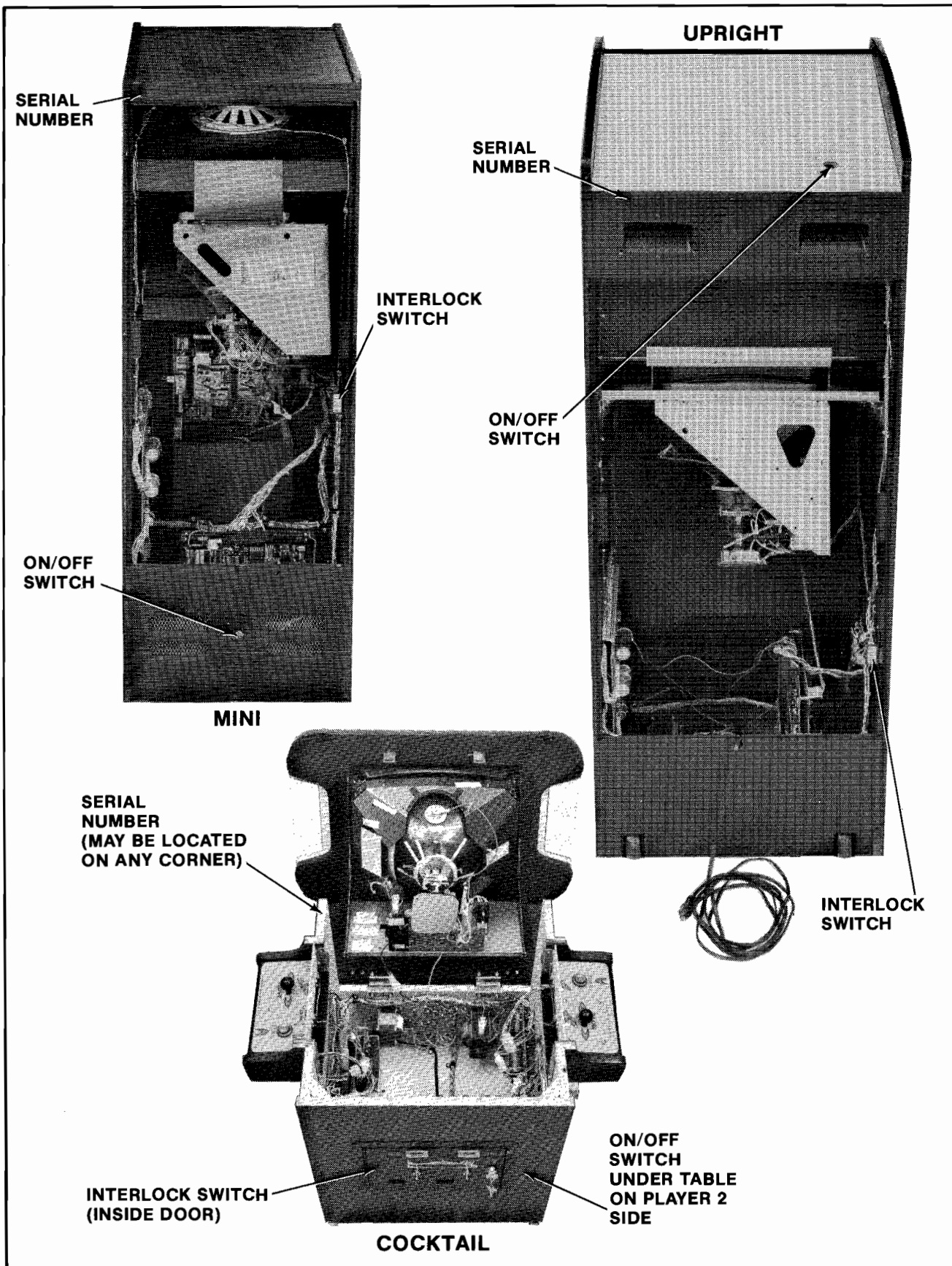

Figure 1. Location of serial number, interlock switch and ON/OFF switch.

- When any access door is opened, the interlock switch installed there turns off all power to the game.
- Check each interlock switch for proper operation.

After checking the line voltage in your area and determining that the input wires to the main power supply transformer of your game are connected properly — or — after obtaining a solution to your over or under voltage problem from your distributor and/or your service man, plug the game into your A.C. wall outlet.

The game ON/OFF switches for all models are located as shown in Figure 1. Turn the game on and allow it to warm up a few minutes.

Slowly open each access door to the game (this **does not** include the coin door on the Upright and Mini models).

As the door is opened approximately 1" (2.54cm) the power to the game should go off (the T.V. monitor, all the lights, and all sounds will stop).

If this does not happen, check the interlock switch by this door to see if it has broken loose from its mounting or if it is stuck in the "ON" position.

If the switch is found to be bad, turn the game off, unplug it, and replace the interlock switch.

When done, plug the game back into the wall outlet, close the access door, and turn the game back on.

After the game has warmed up, repeat the above interlock switch test.

When the interlock switch is working properly and turns the power to the game off, power may be restored to the game with the access door(s) open. Take hold of the interlock switch plunger and **gently** pull it out to its fully extended position. **THIS IS TO BE USED ONLY FOR SERVICING THE GAME.**

### SELF-TEST:

Your new game will Self-Test itself to see if it has any bad parts. The information it receives while testing itself will be shown on the T.V. monitor. Some information can also be heard through the games speaker system. See the GAME OPERATION section for a more detailed description of this function.

When there is a bad result according to the Self-Test, call your distributor and/or service man to have the trouble fixed unless it is something you can do yourself (such as replace a bad RAM or ROM chip).

### GAME VOLUME ADJUSTMENT CONTROL. SEE FIGURE 2.

The game volume control pot is located on the CPU board. The other board is the video board. There is only one pot. For adjustment, it may be reached through the rear access door on the Upright and Mini models. On the Cocktail Table model, you will have to open the table top to reach it.

To make the sounds louder, turn the pot clockwise as you face it (→).

To make the sounds **less** loud, turn the pot counter-clockwise as you face it (←).

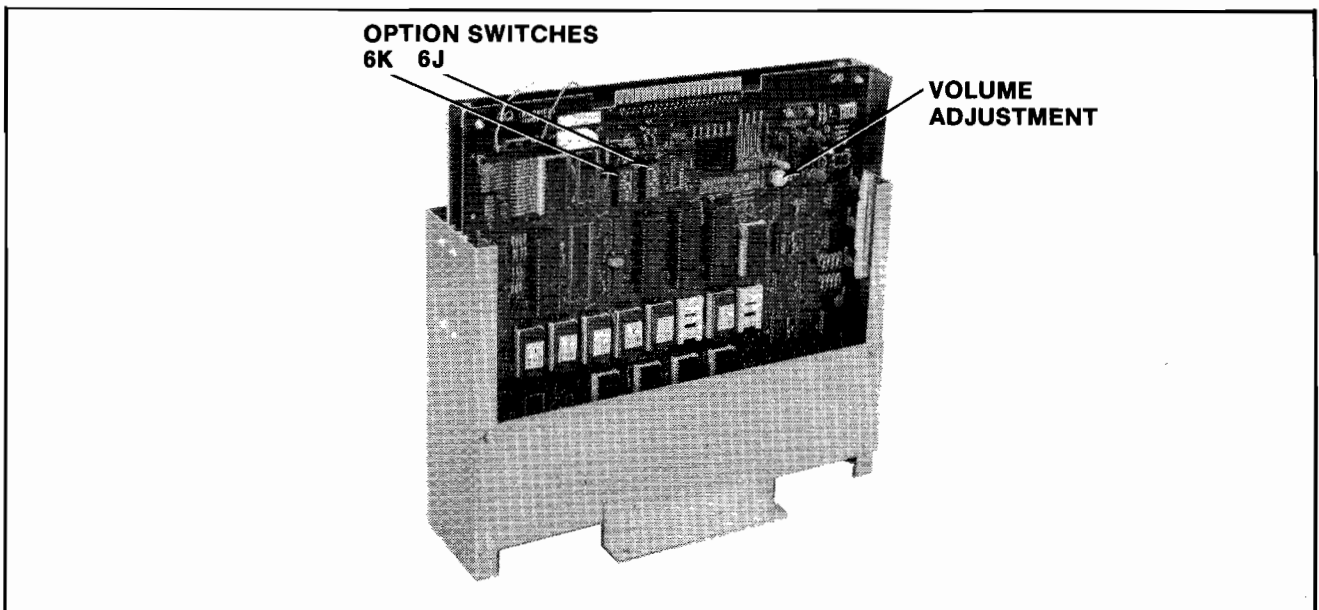

Figure 2. Location of volume control and option switch

**OPTION SWITCH SETTINGS:**

To change the option switch settings, you DO NOT have to take the CPU board out of the game. They can be easily reached through the rear access door on the Upright and Mini models. On the Cocktail Table model, you do have to open the table top to reach them.

When changing any options, ALWAYS perform the Self-Test and play the game to be sure the switches have worked properly and that no switches were accidentally moved that were not meant to be. (These switches are small and this can happen.)

The option switch settings and what they will make the game do are shown in Figure 3. See Figure 2 for option switch locations.

**ELIMINATING THE RAPID (AUTOMATIC) FIRE FEATURE**

If you do not desire the RAPID (AUTOMATIC) FIRE FEATURE on your game, it can be simply and easily eliminated. See the following procedure.

1. Turn the power off to the game.

**Figure 3. Option switch settings**

DIP SWITCH 6J								
	SW#1	SW#2	SW#3	SW#4	SW#5	SW#6	SW#7	SW#8
<b>1 PLAYER GAME</b> PRESS THE 1 PLAYER START BUTTON 2, 3, 4, OR 5 FIGHTERS	OFF						NOT USED	
<b>2 PLAYER GAME</b> PRESS THE 2 PLAYER START BUTTON 2, 3, 4, OR 5 FIGHTERS EACH								
<b>1 PLAYER GAME</b> PRESS THE 1 PLAYER START BUTTON 2, 3, 4, OR 5 FIGHTERS	ON						NOT USED	
<b>1 PLAYER GAME</b> WITH 5, 7, 9, OR 11 FIGHTERS PRESS THE 2 PLAYER START BUTTON								
DIFFICULTY LEVEL SETTINGS — "A" IS THE EASIEST AND "D" IS THE MOST DIFFICULT								
	SW#1	SW#2	SW#3	SW#4	SW#5	SW#6	SW#7	SW#8
RANK "A" - EASIEST LEVEL OF PLAY	OFF	OFF					NOT USED	
RANK "B" - 2ND LEVEL OF DIFFICULTY	ON	ON					USED	
RANK "C" - 3RD LEVEL OF DIFFICULTY	OFF	ON					NOT USED	
RANK "D" - MOST DIFFICULT LEVEL OF PLAY	ON	OFF					USED	
GAME PROVIDES SOUND IN <b>ATTRACT MODE</b> GAME <b>DOES NOT</b> PROVIDE SOUND IN <b>ATTRACT MODE</b>				ON OFF			NOT USED	
FREEZE VIDEO (MONITOR PRESENTATION STOPS MOVING) MONITOR OPERATES NORMALLY					ON OFF		NOT USED	
AUTOMATIC RACK ADVANCE NORMAL OPERATION						ON OFF	NOT USED	
COIN COUNTER								
	SW#1	SW#2	SW#3	SW#4	SW#5	SW#6	SW#7	SW#8
ONE WAY							NOT USED	ON
TWO WAY							USED	OFF

- UPRIGHT and MINI models:  
Unlock and open the rear access door.

**COCTAIL TABLE model:**

If you have this model, you will need to open the table top to reach the necessary terminal board. (See the appropriate opening procedure in the "MAINTENANCE AND REPAIR" section of this manual.)

- Move the plug in the Rapid Fire P.C. Board from position "A"-RAPID, to position "B"-MANUAL.
- To close the game, reverse the opening procedure.
- Turn the power back on, run the game Self-Test, and play one game to make sure everything is working properly.

**Figure 3. Option switch settings (Continued)**

<b>DIP SWITCH 6K</b>											
<b>COINS PER CREDIT</b>											
				<b>SW#1</b>	<b>SW#2</b>	<b>SW#3</b>	<b>SW#4</b>	<b>SW#5</b>	<b>SW#6</b>	<b>SW#7</b>	<b>SW#8</b>
<b>FREE PLAY</b>				ON	ON	ON					
4 COINS		1 CREDIT		ON	ON	OFF					
3 COINS		1 CREDIT		ON	OFF	ON					
2 COINS		1 CREDIT		ON	OFF	OFF					
2 COINS		3 CREDITS		OFF	ON	ON					
1 COIN		3 CREDITS		OFF	ON	OFF					
1 COIN		2 CREDITS		OFF	OFF	ON					
1 COIN		1 CREDIT		OFF	OFF	OFF					
<b>BONUS SHIPS AWARDED AT THE FOLLOWING POINT VALUES:</b>											
<b>BEGAN WITH 2, 3 OR 4 FIGHTERS</b>		<b>BEGAN WITH 5 FIGHTERS</b>		<b>SW#1</b>	<b>SW#2</b>	<b>SW#3</b>	<b>SW#4</b>	<b>SW#5</b>	<b>SW#6</b>	<b>SW#7</b>	<b>SW#8</b>
1st SHIP	20000	1st SHIP	30000				ON	ON	OFF		
2nd SHIP	60000	2nd SHIP	100000								
AND EVERY	60000	AND EVERY	100000								
1st SHIP	20000	1st SHIP	30000				ON	OFF	ON		
2nd SHIP	70000	2nd SHIP	120000								
AND EVERY	70000	AND EVERY	120000								
1st SHIP	20000	1st SHIP	30000				ON	OFF	OFF		
2nd SHIP	80000	2nd SHIP	150000								
AND EVERY	80000	AND EVERY	150000								
1st SHIP	30000	1st SHIP	30000				OFF	ON	ON		
2nd SHIP	100000	2nd SHIP	100000								
AND EVERY	100000										
1st SHIP	30000	1st SHIP	30000				OFF	ON	OFF		
2nd SHIP	120000	2nd SHIP	120000								
AND EVERY	120000										
1st SHIP	20000	1st SHIP	30000				OFF	OFF	ON		
2nd SHIP	60000	2nd SHIP	150000								
1st SHIP	30000	ONE SHIP	30000				OFF	OFF	OFF		
2nd SHIP	80000	ONLY									
<b>NO BONUS SHIPS GIVEN WITH THIS SETTING</b>							ON	ON	ON		
<b>DETERMINES NUMBER OF SPACE FIGHTERS PLAYER BEGINS GAME WITH:</b>											
2 SPACE FIGHTERS										ON	ON
3 SPACE FIGHTERS										ON	OFF
4 SPACE FIGHTERS										OFF	ON
5 SPACE FIGHTERS										OFF	OFF



# Game Operation

GALAGA is a one or a two player game with a color T.V. monitor.

The game has five possible modes of operation: ATTRACT, READY-TO-PLAY, PLAY, HIGH SCORE INITIAL, and SELF-TEST.

## SELF-TEST MODE

The Self-Test mode is a special mode for checking the game switches and computer functions. It is the easiest and best way to check for proper operation of the entire game.

**NOTE:** Putting the game into Self-Test will cause it to erase any CREDITS shown at the lower left corner of the screen from its memory.

You may begin a Self-Test at any time by sliding the Self-Test switch to the "ON" position after the power to the game is on. Test switch is located inside coin door under coin meter. When this is done, the game will react as follows:

1. First, there is an explosion sound (same as when your fighter is hit).
2. Immediately following this, you see an upside down test display which lasts for about 1/2 second. (By pushing both the "1 PLAYER" and the "2 PLAYER" buttons at the same time, the picture will turn upside down and stay that way until you release the buttons.)

3. And last, a rightside up test display is shown on the monitor screen. This will remain until you set the Self-Test switch back to the "OFF" position. This test display is shown below.

```

RAM OK or (a number and a letter i.e. 1L, 3H,
etc.
ROM OK or (a number i.e. 01 21, etc.)
UPRIGHT or (TABLE)
*1 COIN   *1 CREDIT
*3 SHIPS
RANK *A (B,C,D)
SOUND 00 (01,02,03,04,05,06,07,08,09,10,11,12,
13,14,15,16,17)
1ST BONUS *20000 PTS
2ND BONUS *70000 PTS
*AND EVERY 70000 PTS
* = switch selectable
    
```

**Figure 4a. Self test display**

4. If a bad ROM or RAM chip is found by the games internal check system during the Self-Test, the game indicates this to you by showing the location code of the bad chip(s) in place of the letters "OK":

DISPLAY	DESCRIPTION
RAM OK	All RAMs are good
RAM OL	RAM located on Video PC board at position 1K is bad.
RAM OH	RAM located on Video PC board at position 1K is bad.
RAM 1L	RAM located on Video PC board at position 1K is bad.
RAM 1H	RAM located on Video PC board at position 1K is bad.
RAM 2L	RAM located on Video PC board at position 3E is bad.
RAM 2H	RAM located on Video PC board at position 3F is bad.
RAM 3L	RAM located on Video PC board at position 3K is bad.
RAM 3H	RAM located on Video PC board at position 3L is bad.
RAM 4L	RAM located on Video PC board at position 3H is bad.
RAM 4H	RAM located on Video PC board at position 3J is bad.
ROM OK	All ROMs are good.
ROM 01	ROM located on CPU PC board at position 3N is bad.
ROM 02	ROM located on CPU PC board at position 3M is bad.
ROM 03	ROM located on CPU PC board at position 3L is bad.
ROM 04	ROM located on CPU PC board at position 3K is bad.
ROM 11	ROM located on CPU PC board at position 3J is bad.
ROM 21	ROM located on CPU PC board at position 3E is bad.

**Figure 4b. Board location coordinates (Self test display)**

5. "RANK" is a difficulty setting, with "RANK A" being the **least** difficult level of play and "RANK D" being the **most** difficult level of play. See the "OPTION SWITCH SETTINGS" table.
6. To check "SOUND" (the game has 18 different sounds):
  - a) Move the controller to the right momentarily and release it — "SOUND" number changes from "00" to "01".
  - b) Press any game play button or activate the coin switches and sound "01" is heard.
  - c) Repeat Step 6. a) — "SOUND 01" changes to "SOUND 02".
  - d) Repeat Step 6. b) — and "SOUND 02" is heard.
7. To check your game function switches and buttons (coin counter switches, FIRE button, 1 PLAYER and 2 PLAYER buttons): activate each one while the game is in the Self-Test mode. You should hear the same sound during each activation. If you do not hear it, the switch/button is either not working, miswired, or disconnected. Check it out thoroughly.
8. When finished with the Self-Test mode, slide the Self-Test switch back to the "OFF" position.
  - A cross hatch pattern appears on the monitor screen for about 2 seconds.
  - If you wish to keep this test pattern on the monitor screen for further use, slide Self-Test switch back to the "ON" position **after** the cross hatch appears and **before** it disappears.
  - When finished with the cross hatch pattern, set Self-Test switch to the "OFF" position.
  - Normal game functions will now return to the monitor screen.

## ATTRACT MODE

1. **The Attract mode starts:**
  - Just after power has been turned on to the game. (Self-Test switch is in the "OFF" position.)
  - After a Self-Test has been completed. (Performing a Self-Test sets the credits in the games memory to zero "0".)
  - After a play has been finished, the score was not high enough to put the game into the High Score/Initial mode, and there are no more credits left in the games memory.
  - After the High Score/Initial mode when there are no more credits left in its memory.

## READY-TO-PLAY MODE

1. The Ready-To-Play mode starts when enough coins have been accepted for a 1 or a 2 player game.

2. The Ready-To-Play mode ends when either the "1 PLAYER" or the "2 PLAYER" push button is pressed.

## PLAY MODE

1. The Play mode begins when either the "1 PLAYER" or the "2 PLAYER" start button is pressed. "PLAYER 1", "STAGE 1" is displayed **centered** on the screen.
2. The Play mode ends when all of your space fighters have been destroyed. when this happens, "GAME OVER" is written across the center of the monitor screen.
3. The game is made up of convoys of invading alien space ships. You, as defender, try to destroy as many convoys as you can.
4. The convoys are displayed one at a time at the top of the screen. They are made up of GALAGA COMMAND SHIPS, RED GALAGAS, and BLUE GALAGAS. These ships fly onto the screen from different angles, going by your position (giving you an opportunity to shoot them down) and then take up their positions in the convoy formation at the top of the screen.

In the first STAGE, the enemy ships do not drop bombs on you as they fly onto the screen and go by your position. However, they will in later stages.

After the convoy (or what's left of it after you've finished shooting at them as they fly onto the screen and head for their respective spots in the convoy formation) finishes forming up at the top of the screen, enemy ships will begin peeling off and diving at your fighter. They weave back and forth across the screen dropping bombs all the while.

The GALAGA COMMAND SHIPS can put out a tractor beam and capture your fighter. When this happens, that fighter changes color from white to red and stays with that particular enemy COMMAND SHIP for the rest of the game. You can get your fighter back by destroying the GALAGA COMMAND SHIP that captured it while they are both attacking your current fighter. The GALAGA COMMAND SHIPS **MUST BE SHOT TWICE** to destroy them. When shot once, they change color from green to blue. When shot again, they explode. If, however, you mistakenly shoot the captured fighter, it will be destroyed. At that time, if the captured fighter is in a stand-by position in the convoy formation — 500 points will be added to your score; if the captured fighter is attacking — 1000 points will be added to your score.

The RED and BLUE GALAGAS will explode as soon as they are hit by one of your shots.

There are also special attack squadrons made up of three ships each which will appear from STAGE 4 on. If they are completely destroyed, bonus points will be awarded as follows:

**STAGES 4-6**                    1000 BONUS POINTS  
**STAGES 8-10**                  2000 BONUS POINTS  
**STAGES 12-14**                3000 BONUS POINTS

When you destroy the last ship of a convoy, the screen gives the following display **centered** on the monitor screen:

**"STAGE       "**

(And the number of the next stage.)

The only exception to this would be when the next STAGE is a CHALLENGING STAGE. The first CHALLENGING STAGE comes at the end of the 2nd STAGE. After this, they come at the end of every third STAGE. When you destroy the last ship of the 2nd, 6th, 10th, 14th, 18th, etc. convoys, you will see this display **centered** on the monitor screen:

**"CHALLENGING STAGE"**

A CHALLENGING STAGE is made up of 40 enemy ships that fly by your fighter in 5 groups of 8 ships each while describing varying patterns. They do not drop any bombs and the object is to shoot down as many of them as you can. When you shoot down one COMPLETE formation of 8 enemy ships, bonus points (between 1000 and 3000 depending on the STAGE) are added to your score. If you can destroy all 40 GALAGAS, you will be awarded a SPECIAL BONUS OF 10000 POINTS for that particular CHALLENGING STAGE. When you destroy all 40 GALAGAS, you will see this display **centered** on the monitor screen:

**"PERFECT !"**                flashes  
**"NUMBER OF HITS 40"**  
**"SPECIAL BONUS 10000 PTS"**

Otherwise, after each CHALLENGING STAGE is over, the game gives this display **centered** on the monitor screen:

**NUMBER OF HITS**    \_\_\_ \_\_\_  
**BONUS**                \_\_\_ \_\_\_ \_\_\_

(The BONUS is 100 times the NUMBER OF HITS.)

The next display the game always gives is shown below and is **centered** on the monitor screen.

**"STAGE       "**

(And the number of the next stage.)

As you destroy more convoys, the attacks on you become faster, are in a more rapid succession, and follow trickier flight patterns. For instance, they will try to trap you in a cross fire, or in one corner of the screen, etc. You've really got to watch them closely. If they can't bomb you, they'll ram you in the rear. That's one of their favorite tricks, to fly in a circle and come up behind you.

When the enemy happens to destroy one of your fighters, assuming you have at least one reserve fighter left, the word "READY" appears **centered** on the monitor screen BEFORE play begins again.

When the enemy destroys or captures your **last** fighter, the words "GAME OVER" are displayed **centered** on the monitor screen. The next thing the game does is to display your "RESULTS" statistics. See the following sample display.

**1 UP**                                **HIGH SCORE**                        **\*2 UP**  
000000                                000000                                000000

**RESULTS**  
SHOTS FIRED    \_\_\_ \_\_\_  
NUMBER OF HITS    \_\_\_ \_\_\_  
HIT-MISS RATIO    \_\_\_ . \_\_\_ %

stage markers                    

\*ONLY SHOWN IF THE LAST GAME WAS A TWO PLAYER GAME.

If your score was high enough to become one of the five best scores, the game will go into the High Score/Initial mode immediately after the Results mode. If your score is not high enough to cause the game to go into the High Score/Initial mode, it will either go to the Attract mode (if there are no more credits left in its memory) or into the Ready-To-Play mode (if there are still credits left in its memory).

When in the High Score/Initial mode, there are three "A"'s under the top "NAME" heading on the screen. The first "A" is yellow and flashing on and off. The other two "A"'s are white. Farther down the screen under the "TOP 5" heading, your score has been entered in bright yellow and the space for your initials is blank. All other scores are white.

By moving the controller stick to the right, the flashing letter can be made to sequence forward through the alphabet: "A", "B", "C", "D", etc. By moving the controller stick to the left, the flashing letter can be made to sequence backward through the alphabet: "Z", "Y", "X", "W", etc.

When you reach your initial, release the controller and push the FIRE button. Your initial is frozen in place and appears in the blank space opposite your score, just press the FIRE button three times. Three "A"'s will appear opposite your score.

After the High Score/Initial mode, the game will either go to the Attract mode (if there are no more credits left in its memory) or into the Ready-To-Play mode (if there are still credits left in its memory).

Most of the above holds true in the "2 PLAYER" mode also. But there are a few minor differences.

## TWO PLAYER OPERATION

The Upright, Mini, and Cocktail Table models all have two player operation.

In the two player mode, the rules of play are the same as in the single player mode. There are some additional rules, however.

1. In the Upright and Mini models, the players must take turns at the controls.
2. In the Cocktail Table model, each player has his own set of individual controls. The picture will flip to face you when it is your turn. (When it is not your turn, your set of controls will have **NO** effect on the game.)
3. Your turn lasts until the enemy blows up your space fighter. At this point, the game will do one of several things depending on whether or not the destroyed fighter was your last or if you still have others remaining in reserve.

### FIGHTER DESTROYED — FIGHTERS REMAINING IN RESERVE

- The attack stops and the remainder of the enemy convoy flies off the top of the screen in formation.
- Next, "PLAYER " - "STAGE " is displayed (whenever a new convoy is going to come onto the screen) otherwise it just displays "PLAYER " - "READY" while

what's left of the previously formed convoy flies onto the top of the screen.

- Play begins for the other player.

### FIGHTER DESTROYED OR CAPTURED — NO FIGHTERS REMAINING IN RESERVE

- Game displays "PLAYER " - "GAME OVER".
- Next, it goes to the "RESULTS" mode.
- After the "RESULTS" mode, if your score was high enough, it goes to the "HIGH SCORE/INITIAL" MODE.

After this mode, the game will display "PLAYER " - "STAGE " (whenever a new convoy is going to come onto the screen) otherwise it just displays "PLAYER " - "READY" while what's left of the previously formed convoy flies onto the top of the screen and play begins for the other player.

If your score was not high enough to cause the game to go into the "HIGH SCORE/INITIAL" mode, the game will display "PLAYER " - "STAGE " (whenever a new convoy is going to come onto the screen) otherwise it just displays "PLAYER " - "READY" while what's left of the previously formed convoy flies onto the top of the screen and play begins for the other player.

## **III Maintenance and Repair**

# Maintenance and Repair

Your GALAGA game needs certain types of maintenance to keep it in good working order. Clean, well maintained games attract players and earn more profits.

The most important thing for you to remember is to run the Self-Test EVERY TIME you collect money from the coin box. **JUST LOOKING** at your game **WILL NOT** tell you if all its controls and inside parts are working correctly. The Self-Test will inform you whether or not your game is working the way it should.

The second most important thing you should remember is to clean the outside of the game and coin acceptor mechanisms on a regular basis.

## CLEANING

The outside of the game cabinet plus the metal can be cleaned with any non-abrasive household cleaner. However, the front of the T.V. monitor tube and **both sides** of all other glass and plastic on or in the game **MUST** be cleaned with anti-static cleaner **ONLY**. For cleaning the coin acceptors; hot soapy water may be used on the plastic ones and any household cleanser may be used on the metal ones. If you wish, special coin machine cleaners that leave no residue may be purchased from your distributor.

DO NOT dry-wipe any of the plastic panels. This is because any dust that was on them can scratch their surfaces. If this has happened, anyone looking through this type of damaged plastic would feel he was looking at the game through a fog. This fogging damage **CAN NOT** be repaired or reversed. The **ONLY** solution is to **replace** the damaged piece of plastic.

## FUSE REPLACEMENT

### 1. UPRIGHT MODEL:

As viewed from the back, facing the cabinet, with the rear access door removed; the fuses are located on the Mech. Panel and the Power Supply Board.

### 2. MINI MODEL:

As viewed from the back, facing the cabinet, with the rear access door removed; the fuses are located on the Mech. Panel and the Power Supply Board.

### 3. COCKTAIL TABLE MODEL:

As viewed from the coin door side of the cabinet, with the monitor tilted open to one side; the fuses are located on the Mech. Panel and the Power Supply Board.

Replace fuses **ONLY** with the type and size listed in the Illustrated Parts Breakdown Section of this manual.

See the T.V. Monitor Manual (available on request from your distributor or the monitor manufacturer) and/or the T.V. Troubleshooting Section of this manual for information on these fuses.

## OPENING THE CONTROL PANEL.

### 1. UPRIGHT MODEL:

- **The control panel is held in place by three latches; one on the left side, one on the right side, and one in the center of the front of the cabinet.**

They are spring loaded to provide constant positive pressure on their latch plates.

They can be reached through the coin door **AFTER** turning power to the game off.

To release the latches, lift up and toward the center of the control panel.

Once they are released, unhook them from their latch plates.

- **To remove the control panel:**

Raise it up and tilt it toward you until you can see the cable behind it.

Cradling the control panel between yourself and the cabinet, disconnect it from its cabling.

The control panel is now free and can be removed.

- **To reinstall the control panel, reverse this procedure.**

### 2. MINI MODEL:

- **The control panel is held in place by two latches, one on the right side and one on the left side of the cabinet.**

They are spring loaded to provide constant positive pressure on their latch plates.

They can be reached through the coin door **AFTER** turning power to the game off.

To release the latches, lift up and toward the center of the control panel.

Once they are released, unhook them from their latch plates.

- **To remove the control panel:**

Raise it up and tilt it toward you until you can see the cable behind it.

Cradling the control panel between yourself and the cabinet, disconnect it from its cabling.

The control panel is now free and can be removed.

- To reinstall the control panel, reverse this procedure.

### 3. COCKTAIL TABLE MODEL:

- Each control panel is held in place by several screws, two on the inside of the cabinet and three along the outside bottom edge of the control panel.

Turn power to the game off.

Open the coin box door and release the two latches indicated in Figure 5.

**CAUTION:**  
The right hand latch is very close to the HIGH VOLTAGE on the monitor.

Once they're released, unhook them from their latch plates.

Grasp the table top at "A" and open it as indicated in Figure 5.

**CAUTION:**  
Due to the weight of the monitor, EXTREME CARE MUST be taken when opening the cabinet.

Remove the screws which secure the control panel in place.

- To remove the control panel(s):

Disconnect it from its cabling.

The control panel is now free and can be removed.

- To reinstall the control panel, reverse this procedure.

## REMOVAL OF THE MAIN-DISPLAY-GLASS AND/OR THE T.V. BEZEL ASSEMBLY

### 1. UPRIGHT MODEL:

**NOTE:** To do this, the latches which secure the control panel MUST be released. The control panel need not be removed. See the "UPRIGHT MODEL" procedure.

- Turn the power to the game off and remove the rear access door.
- Remove the screws from the glass support bracket and lift it out the back of the cabinet.
- Grasp the main-display-glass in the top center, lift up slightly and pull it out the rear of the cabinet.
- Loosen the screws which secure the T.V. bezel-glass-clamps in place.  
Move the clamps to the side and the bezel glass may be removed.  
Remove the above mentioned screws and the bezel with four bezel-glass-clamps may be removed.
- To reinstall the T.V. bezel assembly and the main-display-glass, reverse this procedure.

### 2. MINI MODEL:

**NOTE:** In order to do this, the control panel MUST be removed first. See the "MINI MODEL" procedure.

- Turn the power off to the game and remove the control panel.

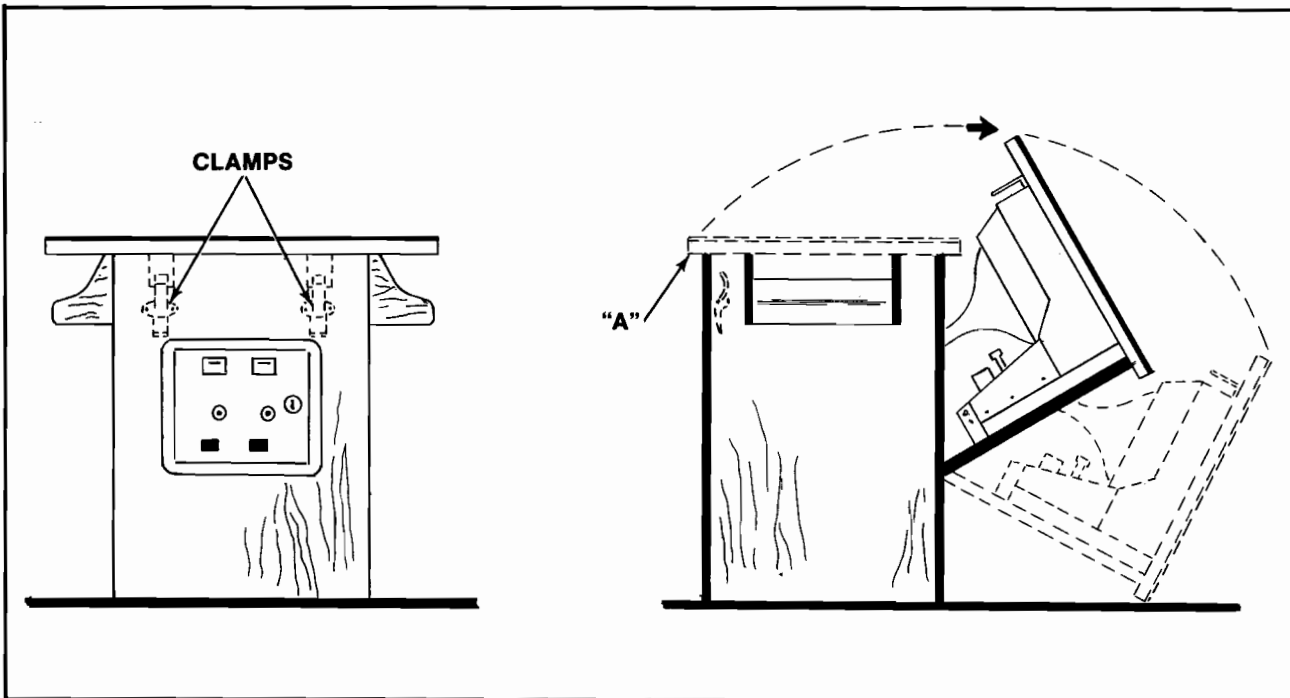

Figure 5. Opening Cocktail game

- Remove the screws which secure the glass clamping plate.
- Lift out the glass clamping plate. This frees the main-display-glass so it can be lifted up.
- By putting your finger in the hole in the middle of the main-display-glass support, you can lift it up and out.
- Remove the screws which secure the T.V. bezel assembly and lift it out.

**NOTE:** Use the hole in the center of the main-display-glass support to grasp it.

- Reverse this procedure to reinstall the T.V. bezel assembly and the main-display-glass.

### 3. COCKTAIL TABLE MODEL:

**NOTE:** This may be done with the table top in the open or the closed position. If you decide to open the table top, **TURN THE POWER TO THE GAME OFF FIRST.**

- Remove the screws which secure the table top glass clamps in place.
- Remove the table top glass.
- Lift out the T.V. bezel assembly.
- To reinstall the T.V. bezel assembly and the table top glass, reverse this procedure.

## T.V. MONITOR REPLACEMENT

### CAUTION:

High voltages may exist in any television unit, even with the power disconnected. Use **EXTREME CAUTION** and do not touch electrical parts or the T.V. yoke area with your hands or with metal objects held in your hands!

In addition, **BE SURE TO USE HEAVY GLOVES** when handling the monitor. You could cut your hands on the metal T.V. chassis without such protection.

### DANGER:

The T.V. monitor **DOES NOT** contain an isolation transformer on its chassis (it is mounted instead on the floor of the cabinet). When servicing the monitor on a test bench, **YOU MUST ISOLATE THE MONITOR FROM AC VOLTAGE WITH AN ISOLATION TRANSFORMER.**

### 1. UPRIGHT MODEL. SEE FIGURE 6

- Turn power off to the game.
- Open the rear access door.
- Completely disconnect the T.V. monitor from all its cabling. **DON'T FORGET THE CHASSIS GROUND WIRE.**

Before removing the T.V. monitor, the main-display-glass and bezel must be removed. See above "Upright Model" procedure.

With the removal of only four bolts, the T.V. monitor and its mounting channels will be loose.

The monitor mounting channels slide on top of and against two metal guides mounted to the cabinet's right and left sides. The monitor is removed by sliding it out the back of the cabinet.

To reinstall the T.V. monitor, be sure to run the game Self-Test.

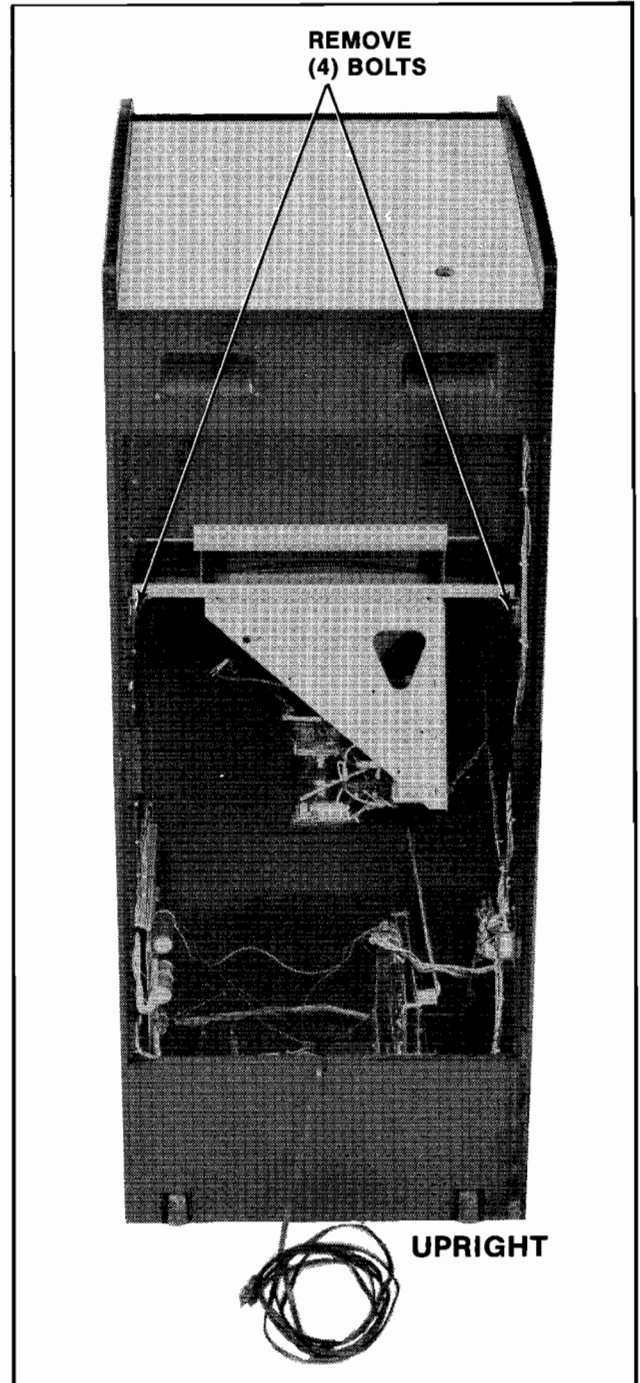

**Figure 6. Removing monitor from Upright game**



## 2. MINI MODEL SEE FIGURE 7

Turn the power off to the game.

Open the rear access door.

Completely disconnect the T.V. monitor from all its cabling. **DON'T FORGET THE CHASSIS GROUND WIRE.**

Before removing the T.V. monitor, the main-display-glass and bezel must be removed. See above "Mini Model" procedure.

With the removal of only four nuts, the T.V. monitor will be loose.

### CAUTION:

**BE SURE to support the T.V. monitor from the rear while removing the four bolts so it will not fall out of the cabinet.**

The monitor is removed by supporting it and pulling straight back.

To reinstall the T.V. monitor, reverse this procedure.

After replacing the T.V. monitor, be sure to run the game Self-Test.

## 3. COCKTAIL TABLE MODEL: SEE FIGURE 8

Turn power off to the game.

Open the coin box door and release the two latches indicated in Figure 5.

### CAUTION:

**The right hand latch is very close to the HIGH VOLTAGE on the monitor.**

- Once the latches are released, unhook them from their latch plates.

- Grasp the table top at "A" and open it as indicated in Figure 5.

### CAUTION:

**Due to the weight of the monitor, EXTREME CARE MUST be taken when opening the cabinet.**

- Remove the screws which hold the table top glass clamps in place.
- Remove the table top glass.
- Lift out the T.V. bezel assembly.
- Completely disconnect the T.V. monitor from all its cabling. **DON'T FORGET THE CHASSIS GROUND WIRE.**
- Remove the screws holding the T.V. monitor chassis to the "L" by the door hinge(s).
- Close the Cocktail Table top and re-latch it.
- Remove the screws which secure the T.V. monitor mounting brackets to the edges of the slot cut in the table top.
- Pry up the end of each monitor mounting bracket with a screwdriver or similar tool until you can grasp them both.
- Lift the T.V. monitor straight up and out of the table top being **VERY CAREFUL** not to bump the neck of the picture tube.
- To reinstall the T.V. monitor, reverse this procedure.
- Be sure to check the clearance of the "L" brackets **BEFORE** setting the monitor into the table top.
- After replacing the T.V. monitor, be sure to run the game Self-Test.

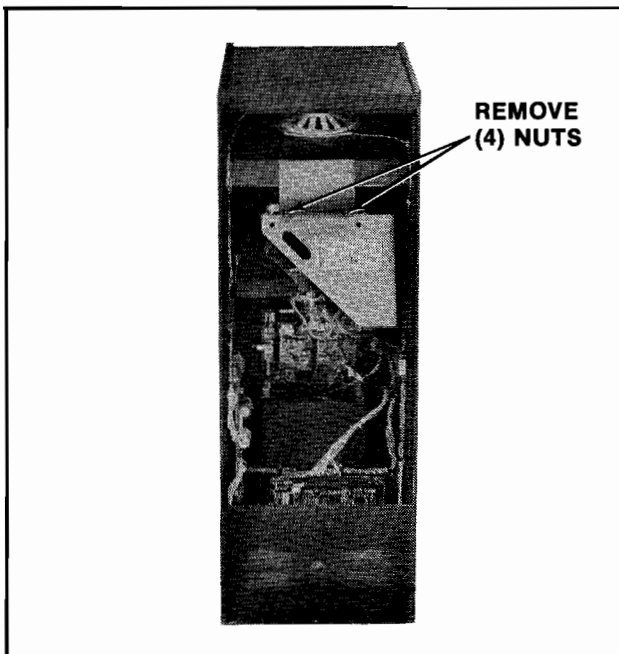

Figure 7. Removing monitor from Mini game

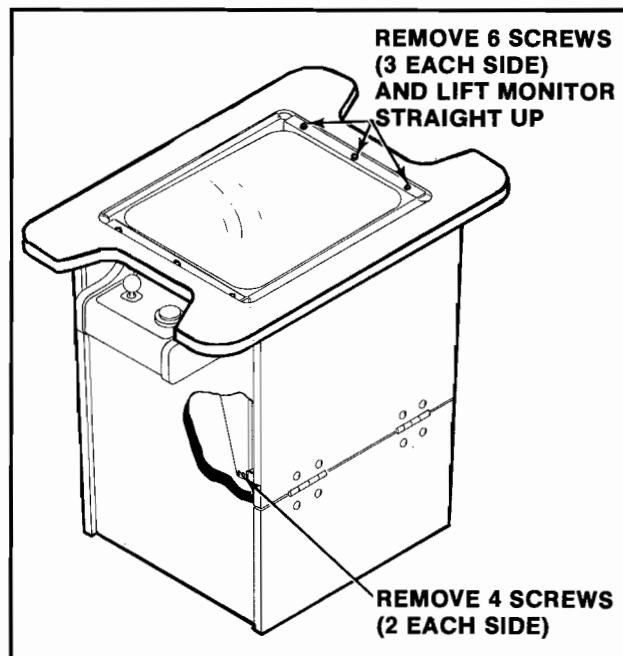

Figure 8. Removing monitor from Cocktail game

## PRINTED CIRCUIT BOARD (P.C.B.) REPLACEMENT

### 1. UPRIGHT MODEL. SEE FIGURE 9

- Turn the power to the game off.
- Unlock and open the rear access door.
- Disconnect the video board from all its cabling.
- Disconnect the CPU board from all its cabling.
- Slide the P.C.B. clamps to one side, remove the P.C.B.'s from the card rack and take them out the back of the cabinet.
- Disconnect the power supply board from all its cabling, remove the P.C.B. supports indicated in Figure 10, and slide it out the back of the cabinet.
- To reinstall the above P.C.B.'s, reverse this procedure.

#### NOTE:

P.C.B.'s are all keyed and will **ONLY** fit into their connectors one way without forcing them. The plugs on the cable harness which connect it to the P.C.B.'s are also keyed and will **ONLY** go onto their connectors one way with out forcing them.

### 2. MINI MODEL. SEE FIGURE 9

- Turn the power off to the game.
- Unlock and open the rear access door.
- Disconnect the video board from all its cabling.
- Disconnect the CPU board from all its cabling.
- Slide the P.C.B. clamps to one side, remove the P.C.B.'s from the card rack and take them out the back of the cabinet.
- Disconnect the power supply board from all its cabling, remove the P.C.B. supports indicated in Figure 9, and slide it out the back of the cabinet.
- To reinstall the above P.C.B.'s, reverse this procedure.

### 3. COCKTAIL TABLE MODEL. SEE FIGURE 9.

- Turn the power off to the game.
- Open the cabinet:  
Open the coin box door and release the two latches indicated in Figure 5.

#### CAUTION:

The right hand latch is very close to the HIGH VOLTAGE on the monitor.

- Once they're released, unhook them from their latch plates.
- Grasp the table top at "A" and open it as indicated in Figure 5.

#### CAUTION:

Due to the weight of the monitor, **EXTREME CARE MUST** be taken when opening the cabinet.

- To remove the power supply board.  
Disconnect it from all its cabling.  
Remove the two smallest P.C.B. supports.  
Once these are removed, the power supply can be lifted out the top of the cabinet.  
To reinstall the power supply board, reverse this procedure.
- To remove the video and CPU boards.  
Disconnect the video board from all its cabling  
Disconnect the CPU board from all its cabling.  
Slide the P.C.B. clamps to one side, remove the P.C.B.'s from the card rack and lift them out the top of the cabinet.  
To reinstall the video and CPU boards, reverse this procedure.

## OPENING THE ATTRACTION PANEL

### 1. UPRIGHT MODEL

- Turn the power to the game off.
- Opening the attraction panel:  
Remove the screws which secure the top bracket in place. (They are on its top side.)  
Remove the top bracket and slide up the attraction panel. This exposes the attraction panel fluorescent light tube and its mounting bracket assembly.  
To reinstall the attraction panel, reverse this procedure.
- The fluorescent light tube may be replaced at this time. **BE CAREFUL NOT TO DROP IT.**

#### WARNING:

If you drop a fluorescent tube and it breaks, **IT WILL IMplode!** Shattered glass can fly six (6) feet or more from the implosion. Use care when replacing any fluorescent tube.

- Replacing the fluorescent tube starter.  
Be sure the power to the game has been turned off.

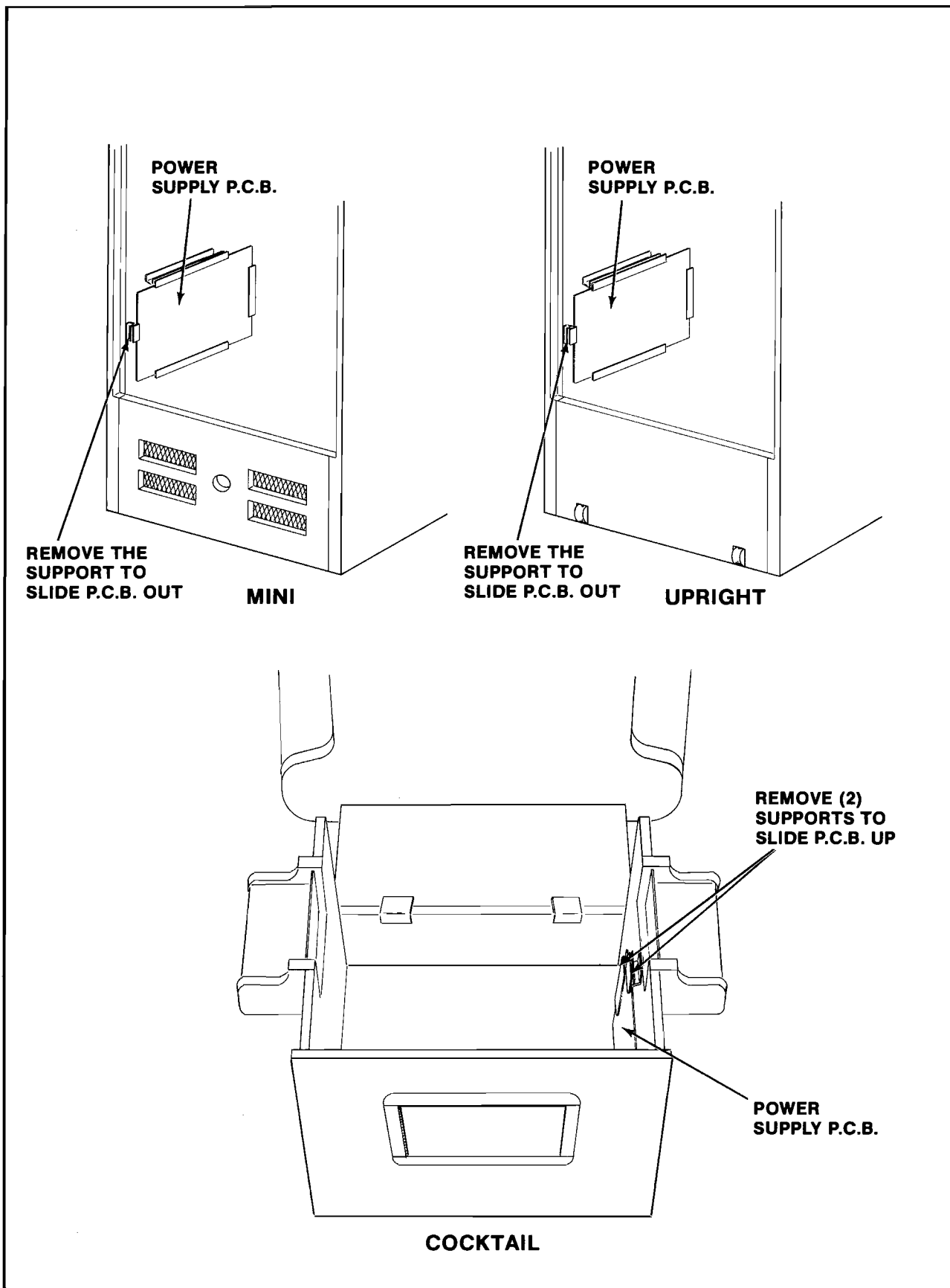

Figure 9. P.C.B. replacement

Grasp the starter (it is on the back of the mounting bracket), give it a quarter turn, and remove it from its socket.

To replace the fluorescent light tube starter, reverse this procedure.

- Replacement of the fluorescent tube mounting bracket assembly.

Be sure the power is off to the game.

Disconnect it from its power cable.

Remove the screws at its right and left hand sides which secure it and gently slide it out the front of the cabinet, being careful not to catch its power cable on anything.

To reinstall the fluorescent tube mounting bracket assembly, reverse this procedure.

- Replacing the speaker.

Be sure the power is off to the game.

Remove the attraction panel and disconnect the speaker from its cabling.

Remove the nuts and bolts which secure the speaker and speaker grill in place and set them and the speaker grill aside.

Once the bolts which secure the speaker in place are removed, the speaker may be removed through the opening where the attraction panel was.

Reverse this procedure to reinstall the speaker.

## 2. MINI MODEL.

- Turn the power off to the game.
- Remove the screws from the top and bottom of the formed attraction panel.
- Remove the formed attraction panel by pulling it straight away from the cabinet. This exposes the attraction panel light bulbs and their mounting board.
- To service the light bulbs and their mounting board:

Turn the power to the game back on so you can see which bulbs are burnt out.

Mark the burnt out bulbs and turn the power to the game back off again.

To replace the burnt out bulbs, grasp them gently and pull straight out.

The new bulbs are gently pushed into the empty sockets.

- To completely replace the light bulb mounting board:

Open the cabinet rear access door and unplug the mounting board from its power cable.

Remove the screws that hold the mounting board to the cabinet.

Gently slide the mounting board out the front of the cabinet being careful not to catch its cable on anything.

To reinstall the above removed items, reverse this procedure.

- To replace the speaker.

Be sure the power is off to the game.

Disconnect the speaker from its cabling.

Remove the nuts and bolts securing the speaker.

Slide the speaker out through the rear access door.

To reinstall the speaker, simply reverse this procedure.

## 3. THE COCKTAIL TABLE MODEL HAS NO BACK-LIT ATTRACTION PANEL.

## COIN DOOR MAINTENANCE:

### METAL COIN ACCEPTOR MECHANISMS

Periodically, the metal coin acceptor mechanism(s) must be removed from the coin door and cleaned.

1. Make sure the power to the game is off.
2. Unlock and open the coin door.
3. Remove the coin acceptor mechanism.
  - Push down on the two spring loaded latches.
  - While holding the latches down, pull the top of the coin acceptor mechanism toward you.
  - Release the latches and lift out the coin acceptor mechanism.
4. Clean the magnet of all foreign particles: See Figure 10.
  - This may be accomplished by swinging the gate open as shown in the above figure.
5. Remove the cradles and undersize levers and clean the bushings. (A pipe cleaner makes a good bushing cleaner.
  - Also clean the pivot pin.
6. Whenever needed, the coin acceptor should be cleaned with hot water and cleanser in the following manner:
  - Place the coin acceptor in boiling water for about ten minutes.

**CAUTION:**  
**BE CAREFUL NOT TO BURN YOURSELF.**

- Next, use a brush and kitchen cleaner to remove all remaining foreign matter from the unit.
- Rinse the coin acceptor in clean boiling water.
- Dry the coin acceptor thoroughly by using filtered compressed air to blow it dry.

**NOTE:**

The reason we recommend using boiling water is that it evaporates faster than cold water and speeds the drying time.

7. To lubricate the coin acceptor:

- Use **ONLY** powdered graphite and put it **ONLY** on the moving parts of the coin acceptor. These parts are called out in Figure 11.
- Be extremely careful to keep the powdered graphite away from paths that are traveled by the coins.

**WARNING**

**DO NOT USE OIL TO LUBRICATE THE COIN ACCEPTOR.**

8. Check the coin chute for obstruction such as: paper, gum, etc.
9. Reinstall the coin acceptor to the coin door.
  - Place the two pegs at the coin acceptors base into their retaining slots.
  - Now push the top of the coin acceptor toward the coin door until it snaps in place and is held there by the two spring loaded latches.
10. Close and lock the coin door.

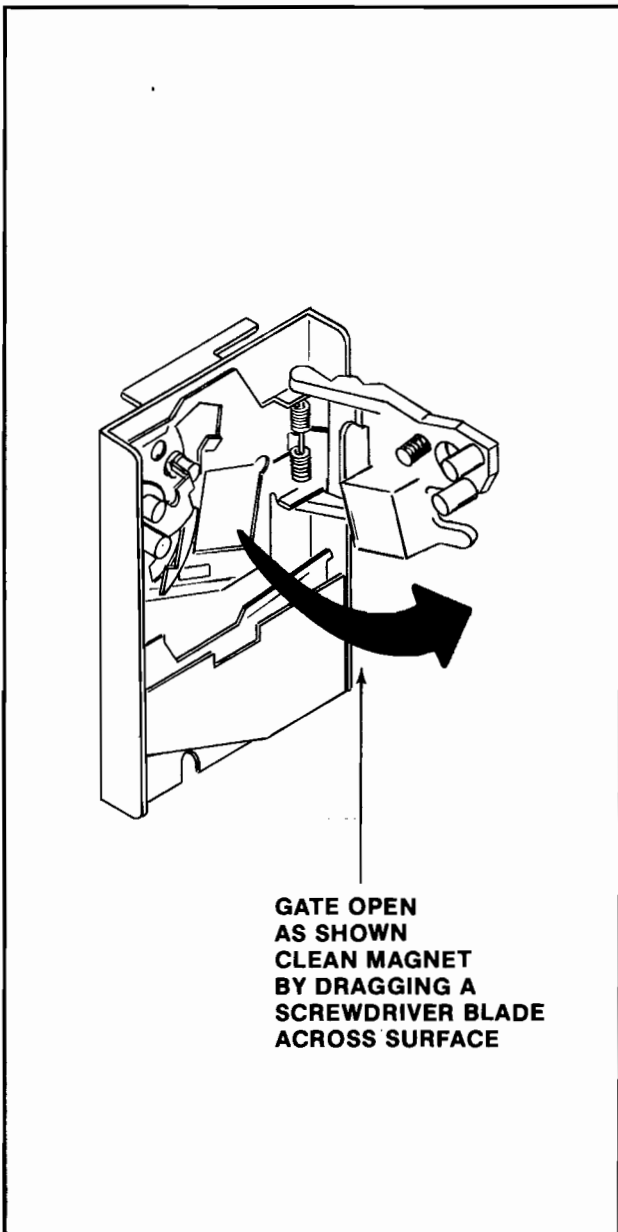

Figure 10. Opening the metal coin acceptor

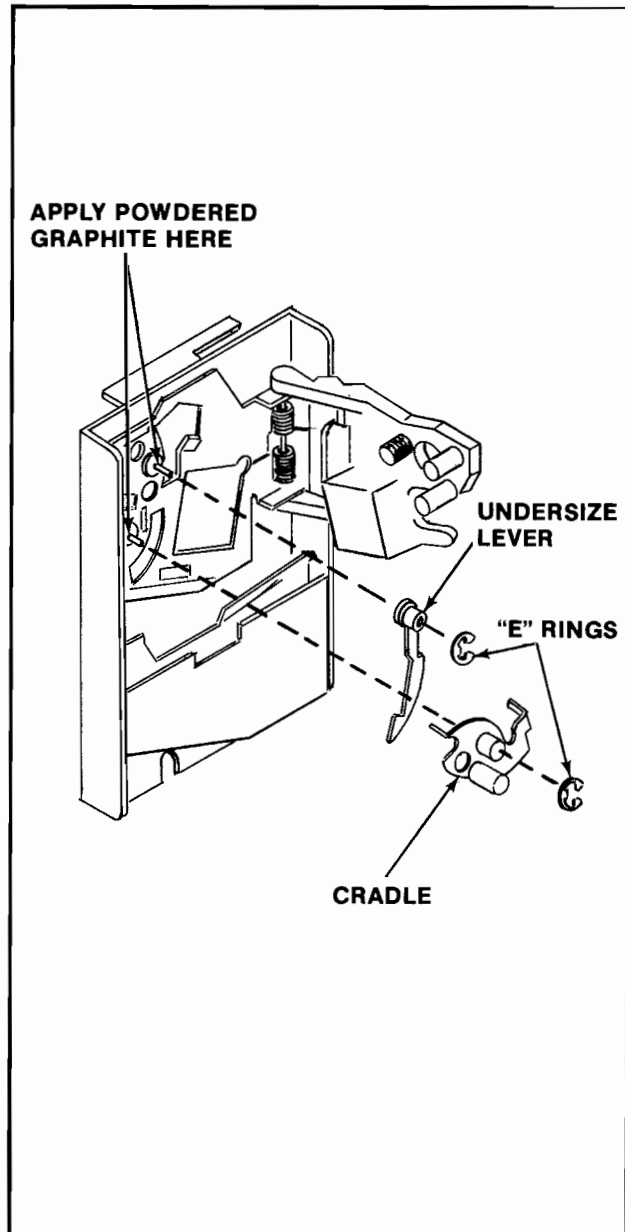

Figure 11. Lubricating the metal coin acceptor

## PLASTIC COIN ACCEPTOR MECHANISMS

The plastic coin acceptor mechanism(s) must be removed periodically from the coin door and cleaned.

1. Make sure the power to the game is off.
2. Unlock and open the coin door.
3. Remove the coin acceptor mechanism(s).
  - Push down on the two spring loaded latches.
  - While holding the latches down, pull the top of the acceptor mechanism toward you.
  - Release the latches and lift out the mechanism.
4. Squeeze the two pins on the mechanisms together to open and break it down into its three basic parts.
  - Clean the mechanism in hot soapy water. It never rusts.
  - Rinse the mechanism in clean hot water and allow it to dry.

- Reassemble the mechanism (it never needs lubrication).
5. Check the coin chute for obstructions such as: paper, gum, etc.
  6. Reinstall the coin acceptor to the coin door.
    - Place the two pegs at the coin acceptors base into their retaining slots.
    - Now push the top of the coin acceptor toward the coin door until it snaps in place and is held there by the two spring loaded latches.
  7. Close and lock the coin door.

### NOTE:

See Figure 12 for instructions on how to set the plastic coin acceptor mechanisms to either accept or reject Canadian quarters.

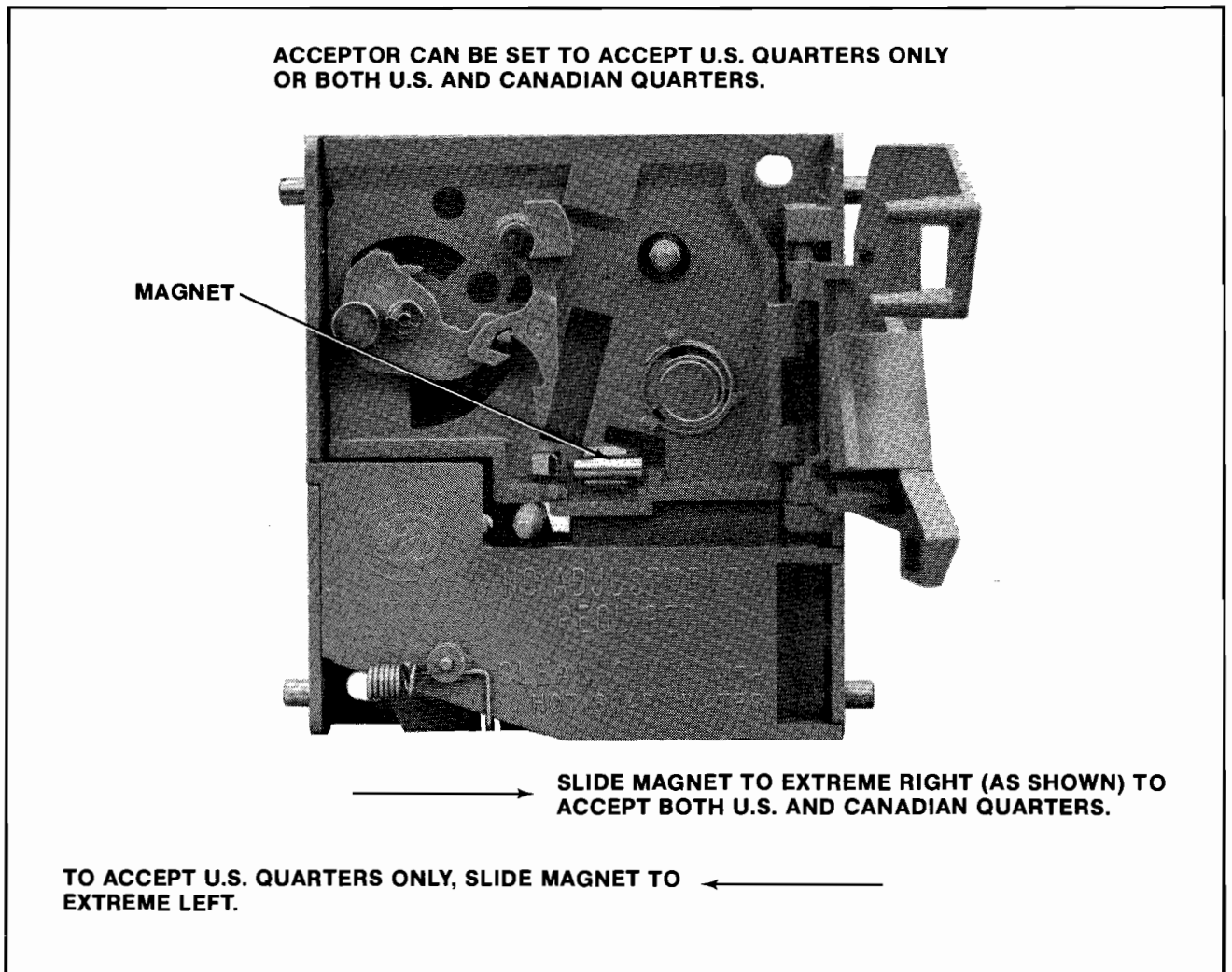
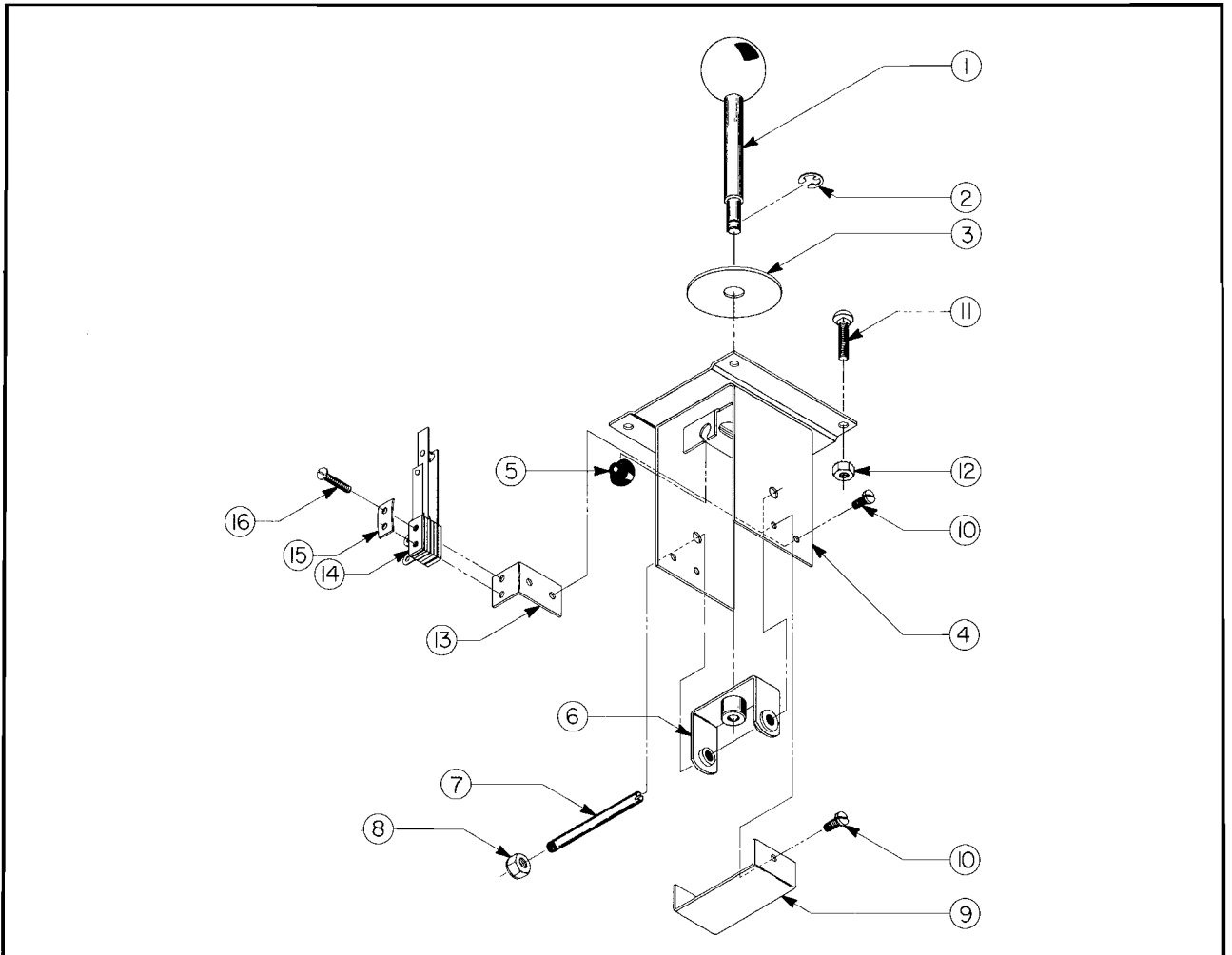

Figure 12. Changing the plastic coin acceptor for American or Canadian Quarters

## **IV Illustrated Parts Breakdown**

**GALAGA — CONTROL ASSEMBLY — ALL VERSIONS**



**GALAGA — CONTROL ASSEMBLY — ALL VERSIONS**

**ORDER BY PART NUMBER ONLY**

ITEM	PART NO.	DESCRIPTION
1	A866-00207-0000	MOLDED 1-3/8" DIA. BALL & SHAFT ASSY.
2	0017-00100-0025	1/4" E-RING
3	0852-00106-0000	FOLLOWER PLATE
4	A508-00021-00XF	TOP PLATE — MAIN CONTROL BRKT. ASSY.
5	0017-00041-0616	RUBBER BUMPER — 90 DUROMETER (2 REQ'D.)
6	A866-00027-0000	PIVOT BRKT. HUB & BEARING ASSY.
7	0852-00701-00XF	PIVOT PIN
8	0017-00103-0011	#10-32 LOCK NUT
9	0508-00112-00XF	BRACE — MAIN BRKT.
10	0017-00101-0755	#6-32 x 5/16 SLT. PAN HD. M.S. (4 REQ'D.)
11	0017-00101-0620	#8-32 x 1/2 RND. CARRIAGE BOLT (4 REQ'D.)
12	0017-00103-0061	#8-32 LOCK NUT W/SEMS (4 REQ'D.)
13	0852-00103-00XF	SWITCH BRKT. (2 REQ'D.)
14	A508-00022-0000	LEAF SWITCH ASSY. (2 REQ'D.)
15	0020-00202-0000	SWITCH PLATE (2 REQ'D.)
16	0017-00101-0737	#5-40 x 5/8 SLT. PAN HD. M.S. (4 REQ'D.)



FRONT DOOR ASSEMBLY — U.S.A. 25¢

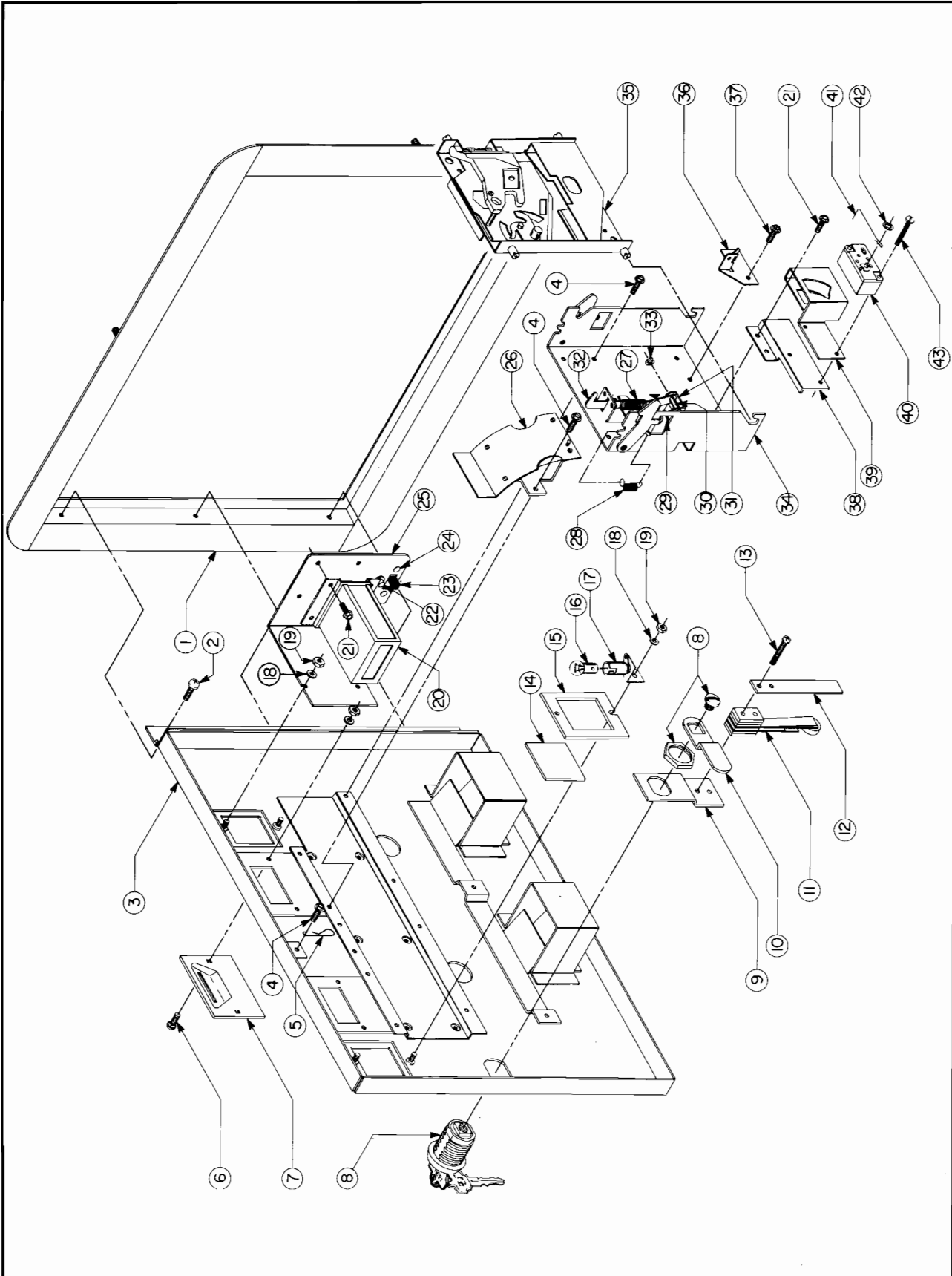

**FRONT DOOR ASSEMBLY — U.S.A. 25¢**

*ORDER BY PART NUMBER ONLY*

ITEM	PART NO.	DESCRIPTION
1	0090-00002-02BK	DOUBLE ENTRY COIN DOOR FRAME
2	0017-00101-0121	#6-32 x 5/16 PHIL. TRS. HD. SCR. (3 REQ'D.)
3	A090-00073-02BK	DOUBLE ENTRY COIN DOOR W/DRESS PLATE
4	0017-00101-0123	#8 x 1/4 UNSLOT. HEX HD. SCREW (4 REQ'D.)
5	0017-00007-0019	KEY HOOK
6	0017-00101-0552	#6-32 x 1/4 CARRIAGE BOLT (4 REQ'D.)
7	0090-00117-03XF	COIN ENTRY PLATE — 25¢ (2 REQ'D.)
8	A097-00005-0000	DOOR LOCK & KEY W/SCREW & NUT (OR)
8	A097-00006-0000	DOOR LOCK & KEY W/SCREW & NUT
9	0090-00128-00XF	DOOR TILT SWITCH BRKT.
10	0017-00005-0041	DOOR CAM
11	A090-00071-0000	DOOR TILT SWITCH
12	0090-00126-01XF	SWITCH BACK-UP PLATE
13	0017-00101-0528	#5-40 x 3/4" PHIL. HD. M.S. (2 REQ'D.)
	A090-00004-0000	DOOR TILT SWITCH & BRKT. ASSY. (ITEMS 9 & 11 THRU 13)
14	0090-00903-9500	25¢ WINDOW (2 REQ'D.)
15	0090-00143-00XF	COIN PLEX RETAINER
16	0017-00003-0052	12 VOLT LAMP — G.E. #1895 (2 REQ'D.)
17	0017-00031-0038	BAYONET SOCKET W/BRKT. (2 REQ'D.)
18	0017-00104-0002	#6 SPLIT LOCK WASHER (8 REQ'D.)
19	0017-00103-0087	#6-32 HEX NUT (8 REQ'D.)
20	A090-00057-0000	COIN METER
21	0017-00101-0124	#6 x 1/4 UNSLOT. HEX HD. SCR. (8 REQ'D.)
22	0017-00032-0051	PUSH BUTTON SWITCH
23	0017-00032-0007	SLIDE SWITCH
24	0017-00072-0034	STEEL OVAL HD. RIVET
25	0090-00173-0000	COIN COUNTER MTG. BRKT.
	A090-00082-0000	TEST SWITCH & BRKT. ASSY. (ITEMS 23 THRU 25)
26	A090-00087-0000	COIN CHUTE & TOP ASSY. (2 REQ'D.)
27	0010-00134-0000	SPRING
28	0010-00181-0000	SPRING
29	0017-00007-0083	1/8 x 1-5/8 ROLL PIN
30	0090-00129-00XF	PIVOT POST
31	0090-00167-00XF	PIVOT LEVER
32	0093-00155-00XF	REJECT LEVER
33	0017-00100-0018	E-RING
	A090-00088-0000	REJECT LEVER ASSY. (2 REQ'D.) (ITEMS 30 THRU 33)
34	A090-00085-0000	COIN ACCEPTOR FRAME ASSY. (2 REQ'D.)
35	0017-00005-0003	COIN ACCEPTOR W/STRING CUTTER (2 REQ'D.) (OR)
35	0017-00005-0211	COIN ACCEPTOR W/ANTI STRING DEVICE (2 REQ'D.) (OR)
35	0017-00005-0214	COIN ACCEPTOR W/STRING CUTTER (2 REQ'D.)
36	A090-00064-0000	ANTI-PENNY DEVICE
37	0017-00101-0099	#6 x 1/4 SLT. HEX HD. M.S. (2 REQ'D.)
38	0090-00162-00XF	COIN SWITCH MTG. BRKT.
39	0017-00005-0203	COIN SWITCH CHUTE
40	0017-00005-0195	COIN SWITCH
41	0010-00599-0000	COIN SWITCH WIRE
42	0017-00007-0132	PUSH-ON RING
	A090-00059-0400	COIN SWITCH & WIRE ASSY. (ITEMS 40 THRU 42)
43	0017-00101-0698	#4-40 x 3/4 SLT. RND. HD. M.S. (2 REQ'D.)
	A090-00077-0000	COIN GUIDE & SWITCH ASSY. (ITEMS 38 THRU 43)

GALAGA — CARD RACK ASSY. W/BOARDS — ALL VERSIONS

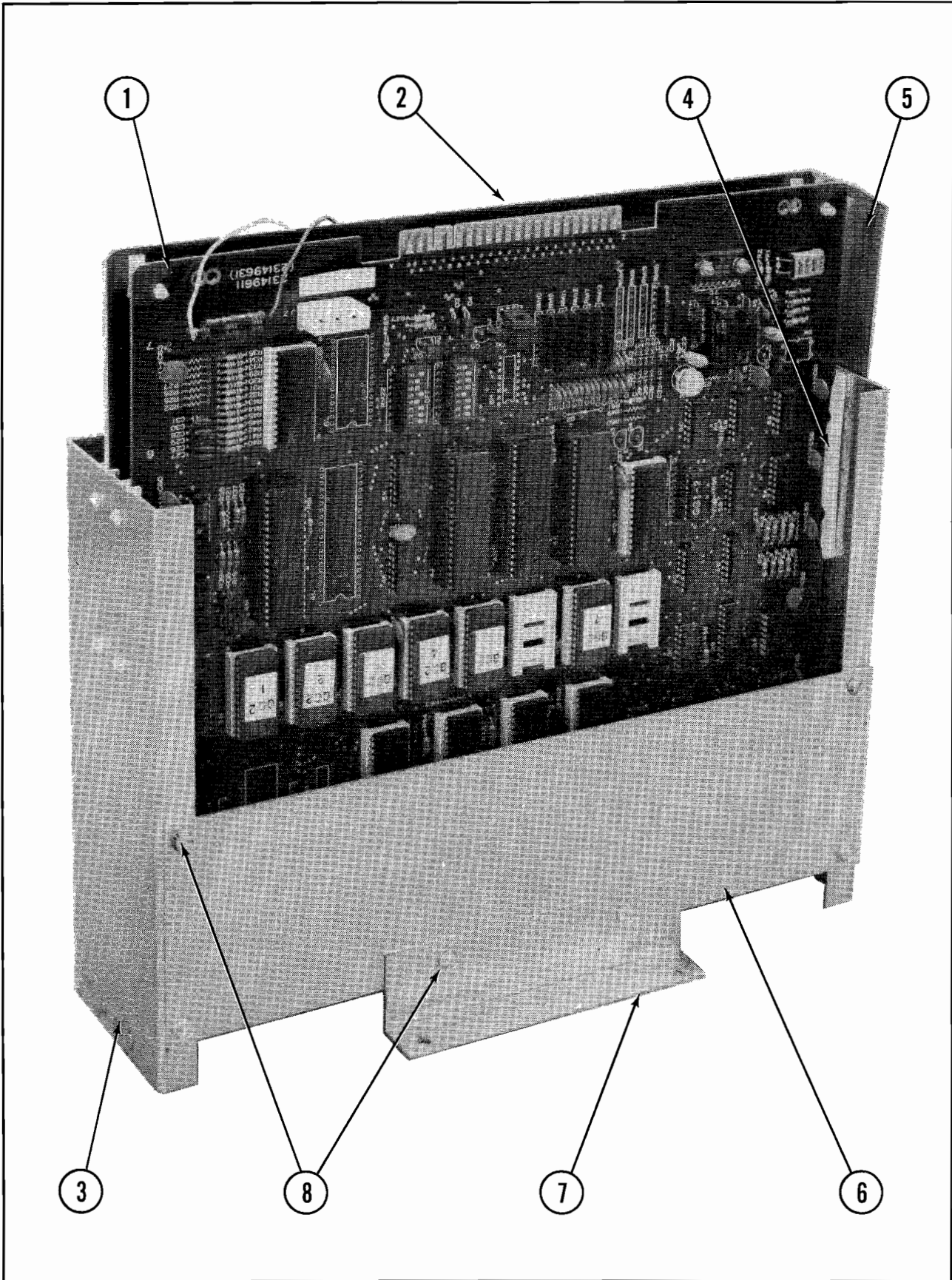

**GALAGA — CARD RACK ASSY. W/BOARDS — ALL VERSIONS**

*ORDER BY PART NUMBER ONLY*

<b>ITEM</b>	<b>PART NO.</b>	<b>DESCRIPTION</b>
1	A084-91404-C508	CPU BOARD ASSY.
2	A084-91405-B508	VIDEO BOARD ASSY.
3	A935-00015-0000	HOLDER PLATE & STOP ASSY. (2 REQ'D.)
4	0017-00009-0478	NYLON GUIDE (4 REQ'D.)
5	0508-00116-0100	P.C. SUPPORT BRKT. — RIGHT
5	0508-00116-0200	P.C. SUPPORT BRKT. — LEFT
6	0935-00103-0000	SIDE SUPPORT (2 REQ'D.)
7	0935-00102-0000	MOUNTING BRACKET (2 REQ'D.)
8	0017-00101-0096	#6 x 3/8 SLT. HEX HD. SCR. (14 REQ'D.)

**GALAGA — TRANSFORMER BOARD ASSY. — PARTS LIST**

*ORDER BY PART NUMBER ONLY*

<b>ITEM</b>	<b>PART NO.</b>	<b>DESCRIPTION</b>
	MT00-00082-0000	TRANSFORMER — 115/115V.
	MT00-00087-0000	POWER TRANSFORMER — 120/240V.
	MT00-00085-0000	TRANSFORMER — 115V., 50 Hz — (COCKTAIL ONLY)
	MT00-00091-0000	SHIELDED TRANSFORMER 115/220V. — (COCKTAIL ONLY)
	0017-00101-0628	#8-32 x 3/4 CARRIAGE BOLT (4 REQ'D.)
	0017-00103-0008	#8-32 HEX NUT (4 REQ'D.)
	0017-00101-0014	#6 x 1/2 SLT. HEX HD. M.S. (15 REQ'D.)
	0720 -00001-0300	3 POSITION FUSE CLIP ASSY. (U.R. & COCKTAIL ONLY)
	0720-00001-0200	2 POSITION FUSE CLIP ASSY. (MINI ONLY)
	0720-00001-0100	1 POSITION FUSE CLIP ASSY.
	0017-00003-0004	SLO-BLO FUSE — 2 AMP, 250V. (2 REQ'D.)
	0017-00003-0002	SLO-BLO FUSE — 1/2 AMP, 250V. (COCKTAIL & U.R. ONLY)
	0017-00003-0217	SLO-BLO FUSE 2-1/2 AMP, 125V.
	0017-00003-0114	NOISE FILTER
	3010-13106-0000	TERMINAL STRIP
	3000-17143-0300	GROUND STRAP ASSY.

NO. 508 — GALAGA UPRIGHT — FRONT

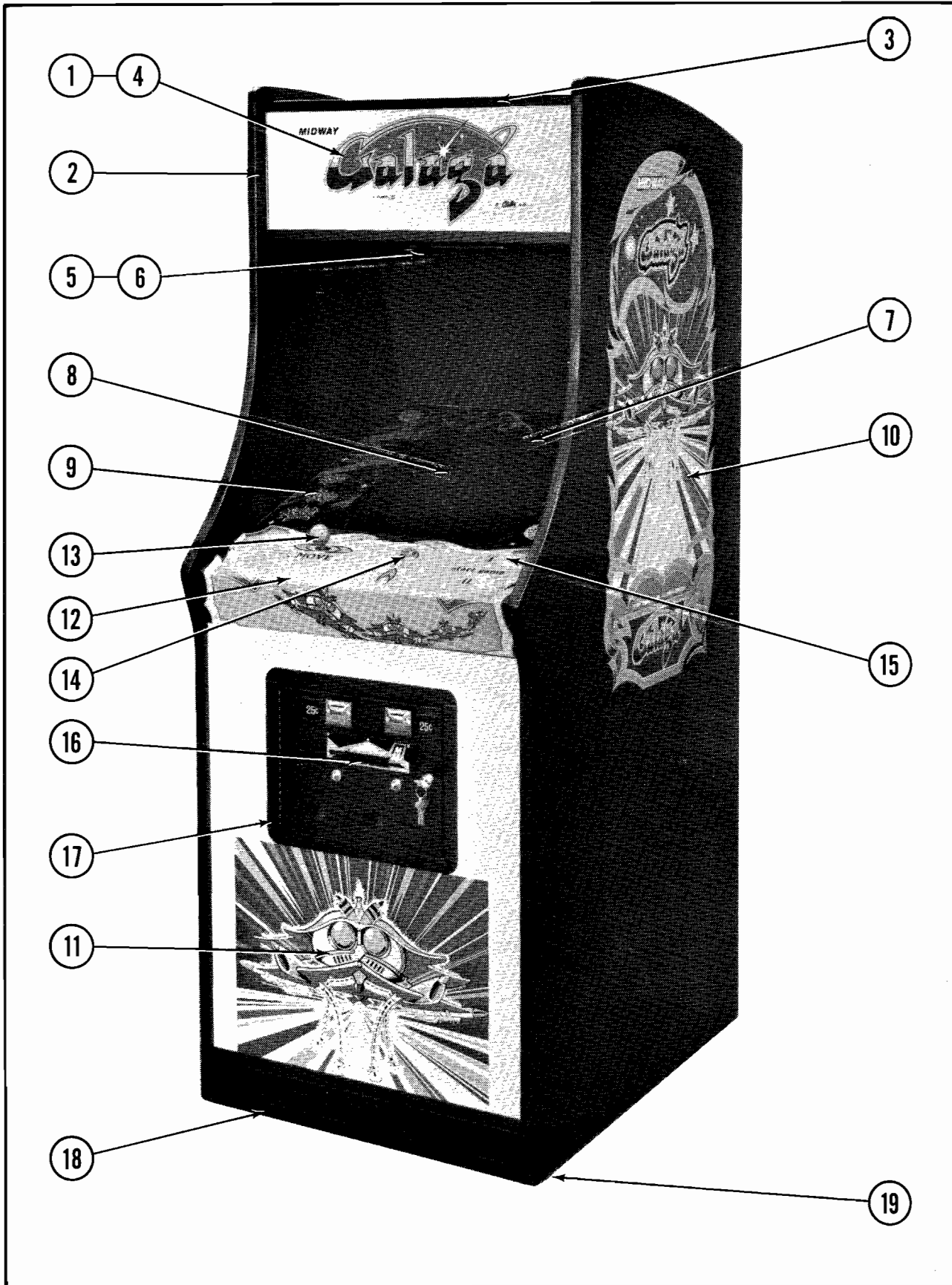

**NO. 508 — GALAGA UPRIGHT — FRONT PARTS LIST**

*ORDER BY PART NUMBER ONLY*

<b>ITEM</b>	<b>PART NO.</b>	<b>DESCRIPTION</b>
1	0508-00903-00XF	UPPER DECORATIVE PLEXI — 23" x 9-1/16" x 3/16"
2	0537-00903-0055	GLASS CHANNEL — 7-3/4" LG. (2 REQ'D.)
3	0508-00104-00XF	UPPER/LOWER HEADER RETAINER (2 REQ'D.)
	0017-00101-0138	#8 x 5/8 TORX TAMPER RESISTANT BLK. SCR. (6 REQ'D.)
	0017-00009-0522	LONG ARM KEY T-20 (FOR ABOVE SCREW)
4	A508-00007-0000	HEADER FLUORESCENT LIGHT ASSY.
5	0017-00009-0393	SPEAKER GRILL — BLACK W/SLOTS
6	0017-00003-0259	6" x 9" SPEAKER 8 OHM, 7W.
	0017-00101-0127	#8-32 x 1-1/2 CARRIAGE BOLT (4 REQ'D.)
	0017-00103-0061	#8- 32 HEX NUT W/SEMS (4 REQ'D.)
7	0508-00900-0000	19" T.V. BEZEL
8	0508-00905-0000	T.V. PLEXI-GLASS (GRAYLITE #31) — 17-3/8" x 13-1/4" x 1/8"
	0508-00901-0000	PLEXI-GLASS CLIPS ( 4 REQ'D.)
	0017-00101-0017	#6 x 1/2 SLT. HEX HD. BLK. SCR. (4 REQ'D.)
9	0508-00902-00XF	MAIN DISPLAY GLASS — 23" x 21-1/8" x 3/16"
	0508-00108-0000	GLASS STOP BRKT.
	0017-00101-0027	#8 x 3/4 SLT. HEX HD. M.S. (3 REQ'D.)
10	0508-00904-0000	DECAL — SIDE (2 REQ'D.)
11	0508-00906-0000	DECAL — FRONT
12	A508-00009-0000	CONTROL PLATE & OVERLAY ASSY.
	A508-00028-0000	CONTROL SHELF PLATE & STRIKE ASSY.
	0508-00907-0000	CONTROL SHELF OVERLAY — DECORATIVE
	0017-00101-0620	#8-32 x 1/2 CARRIAGE BOLT (4 REQ'D.)
	0017-00103-0061	#8-32 HEX NUT W/SEMS (4 REQ'D.)
	0961-00115-00XF	STRIKE (2 REQ'D.)
	0508-00115-0000	CENTER CONTROL SHELF LOCK BRKT.
	0017-00009-0033	BASSICK CLAMP (3 REQ'D.)
	0508-00109-0100	CONTROL SHELF SUPPORT BRKT. — RIGHT
	0508-00109-0200	CONTROL SHELF SUPPORT BRKT. — LEFT
13	A508-00011-0000	CONTROL ASSY.
14	0017-00042-0256	PUSH BUTTON ASSY. — RED
15	0017-00042-0257	PUSH BUTTON ASSY. — YELLOW (2 REQ'D.)
	0017-00032-0093	PUSH BUTTON SWITCH W/HOLDER (3 REQ'D.)
	0017-00103-0054	5/8-11 PAL NUT (3 REQ'D.)
16	A090-00300-07BK	U.S.A. 25¢ COIN DOOR ASSY.
17	0090-00002-02BK	LARGE COIN DOOR FRAME
	0017-00101-0121	#6-32 x 5/16 PHIL. TRS. HD. SCR. (3 REQ'D.) (MOUNTS COIN DOOR TO FRAME)
18	0935-00906-0100	KICK PLATE — 23" LG.
19	0017-00102-0048	3/8-16 x 2" LEG LEVELERS (4 REQ'D.)
	0017-00103-0026	3/8-16 LEG LEVELER HEX NUTS (4 REQ'D.)

NO. 508 — GALAGA UPRIGHT — REAR ACCESS

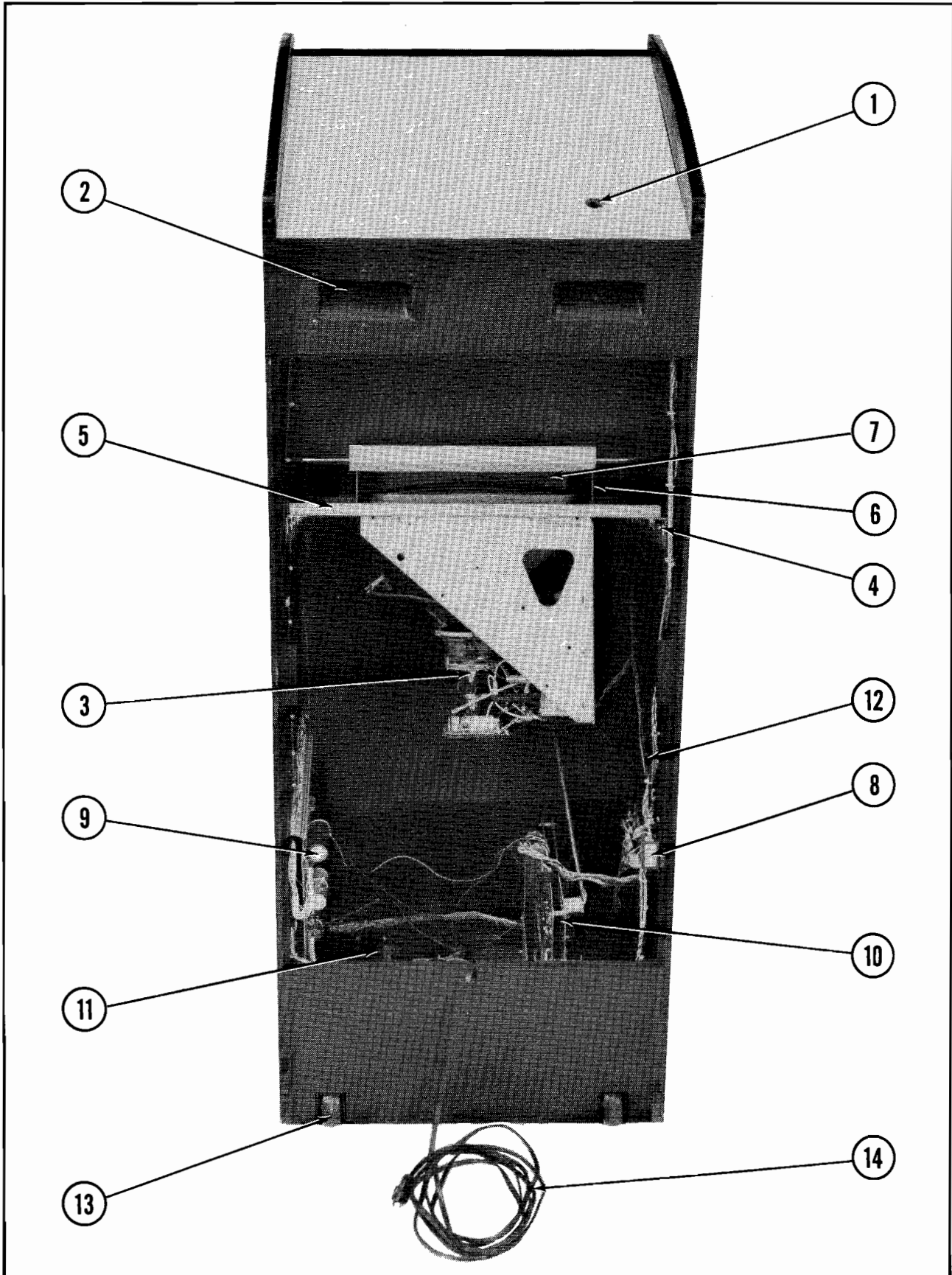



**NO. 508 — GALAGA UPRIGHT — REAR ACCESS PARTS LIST**  
**ORDER BY PART NUMBER ONLY**

ITEM	PART NO.	DESCRIPTION
1	A088-00013-0000	ON-OFF SWITCH & BRKT. ASSY.
2	0894-00913-0000	RECESSED HAND LIFT (2 REQ'D.)
	0017-00101-0117	#8 x 5/8 PHIL. TRS. HD. SCR. (12 REQ'D.)
3	0017-00003-0339	ELECTROHOME — 19" COLOR DUAL SYNC. HORIZ. MTG. MONITOR (OR)
3	0017-00003-0401	WELLS-GARDNER — 19" COLOR DUAL SYNC. HORIZ. MTG. MONITOR
4	A508-00005-0000	MONITOR MTG. CHANNEL ASSY. (2 REQ'D.)
	0017-00102-0066	1/4-20 x 3/4 UNSLOT. HEX HD. BOLT (4 REQ'D.)
5	0508-00100-0000	MONITOR RAIL (2 REQ'D.)
	0017-00102-0002	1/4-20 x 1/2 SLT. HEX HD. BOLT (4 REQ'D.)
	0017-00104-0014	7/8" DISH WASHER (8 REQ'D.)
6	0508-00106-0000	BEZEL MTG. BRKT. (2 REQ'D.)
7	0508-00900-0000	T.V. BEZEL
8	A151-00027-0000	INTERLOCK SWITCH ASSY.
9	A084-91414-C935	POWER SUPPLY ASSY.
	0624-00902-0100	P.C. SUPPORT BRKT. — 12" LG. (2 REQ'D.)
	0624-00902-0300	P.C. SUPPORT BRKT. — 2-1/2" LG.
	0624-00902-0500	P.C. SUPPORT BRKT. — 6-1/2" LG.
	0017-00101-0025	#8 x 1/2 SLT. HEX HD. SCR. (10 REQ'D.)
	0017-00104-0037	#8 FLAT WASHER (10 REQ'D.)
10	A508-00019-0000	CARD RACK W/P.C. BOARDS ASSY.
11	A508-00013-0000	TRANSFORMER BRD. ASSY.
12	A084-91408-B508	FILTER BOARD ASSY. (NOT SEEN)
13	A961-00007-0000	CASTER ASSY. (2 REQ'D.)
	0961-00109-0000	WHEEL BRKT. (2 REQ'D.)
	0017-00042-0255	PLASTIC WHEEL (2 REQ'D.)
	0894-00702-00XF	SHAFT (2 REQ'D.)
	0017-00100-0037	3/8" E-RING (2 REQ'D.)
14	A866-00049-0000	LINE CORD ASSY.
		<b>ADDITIONAL PARTS LIST</b>
	A082-91109-A000	CREDIT MULT. BYPASS P.C. BRD.
	A097-00001-0000	BACK DOOR LOCK ASSY.
	0017-00009-0490	5-5/8 SQ. VENT GRILL — BACK DOOR (4 REQ'D.)
	A508-00014-0000	HIGH VOLTAGE CABLE ASSY.
	A508-00026-0000	COIN DOOR CABLE ASSY.
	A508-00015-0000	LOW VOLTAGE CABLE ASSY.
	A508-00016-0000	MASTER CABLE ASSY.
	A508-00035-0000	MONITOR SIGNAL ADAPTOR CABLE ASSY.
	A508-00018-0000	CONTROL SHELF CABLE ASSY.
	A508-00034-0000	AUDIO ADAPTOR CABLE ASSY.
	A508-00024-0000	SIGNAL CABLE ASSY.
	0017-00009-0477	MOLDED CASH BOX
	A961-00008-0000	CASH BOX COVER ASSY.
	A894-00024-0000	CASH BOX SIDE CHANNEL ASSY.
	0894-00121-0000	CASH BOX SIDE CHANNEL — LONG
	0017-00101-0628	#8-32 x 3/4 CARRIAGE BOLT (4 REQ'D.)
	0017-00104-0022	#8 FLAT WASHER (4 REQ'D.)
	0017-00103-0061	#8-32 HEX NUT W/SEMS (4 REQ'D.)
	3000-17143-0000	GROUND STRAP
	A082-91410-A000	RAPID FIRE P.C. BRD. ASSY.



NO. 508 — GALAGA UPRIGHT — HEADER FLUORESCENT FIXTURE ASSY.

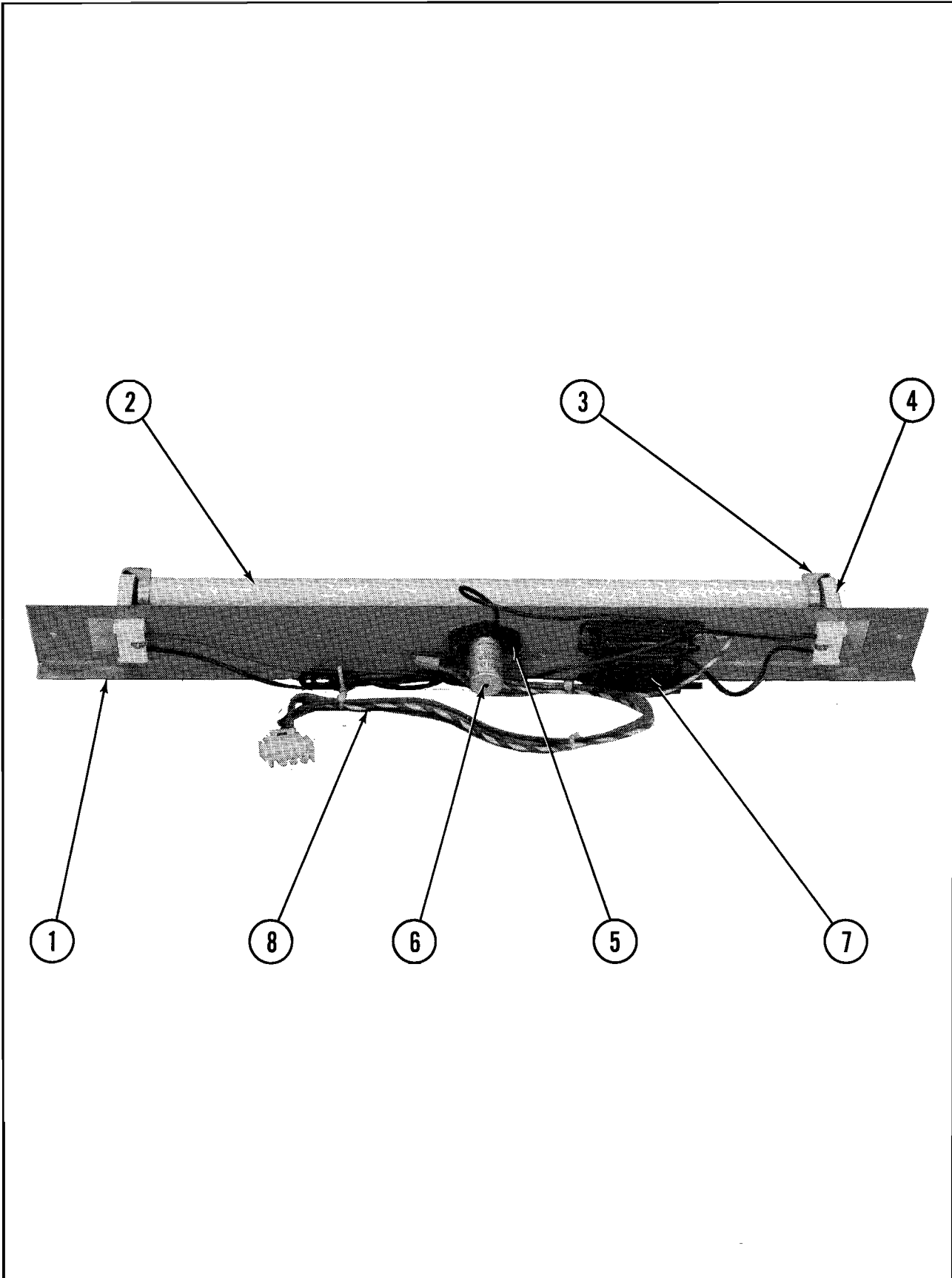

**NO. 508 — GALAGA UPRIGHT — HEADER FLUORESCENT FIXTURE ASSY.**

*ORDER BY PART NUMBER ONLY*

<b>ITEM</b>	<b>PART NO.</b>	<b>DESCRIPTION</b>
1	0508-00103-0000	FLUORESCENT BRKT.
2	0017-00003-0043	18" COOL WHITE FLUOR. LAMP
3	0017-00021-0005	FLUORESCENT LOCKS (2 REQ'D.)
4	0017-00031-0036	FLUORESCENT SOCKET (2 REQ'D.)
5	0017-00003-0412	FLUOR. STARTER HOLDER W/WIRE LEADS
	0017-00101-0573	#6-32 x 1/2 PHIL. RND. HD. M.S. (4 REQ'D.)
	0017-00104-0009	#6 EXT. WASHER (4 REQ'D.)
6	0017-00003-0019	FLUOR. STARTER
7	0017-00003-0026	BALLAST
	0017-00101-0598	#8-32 x 5/16 SLT. HEX HD. SCR. (4 REQ'D.)
8	A508-00017-0000	FLUORESCENT CABLE ASSY.

NO. 514 — GALAGA MINI-FRONT

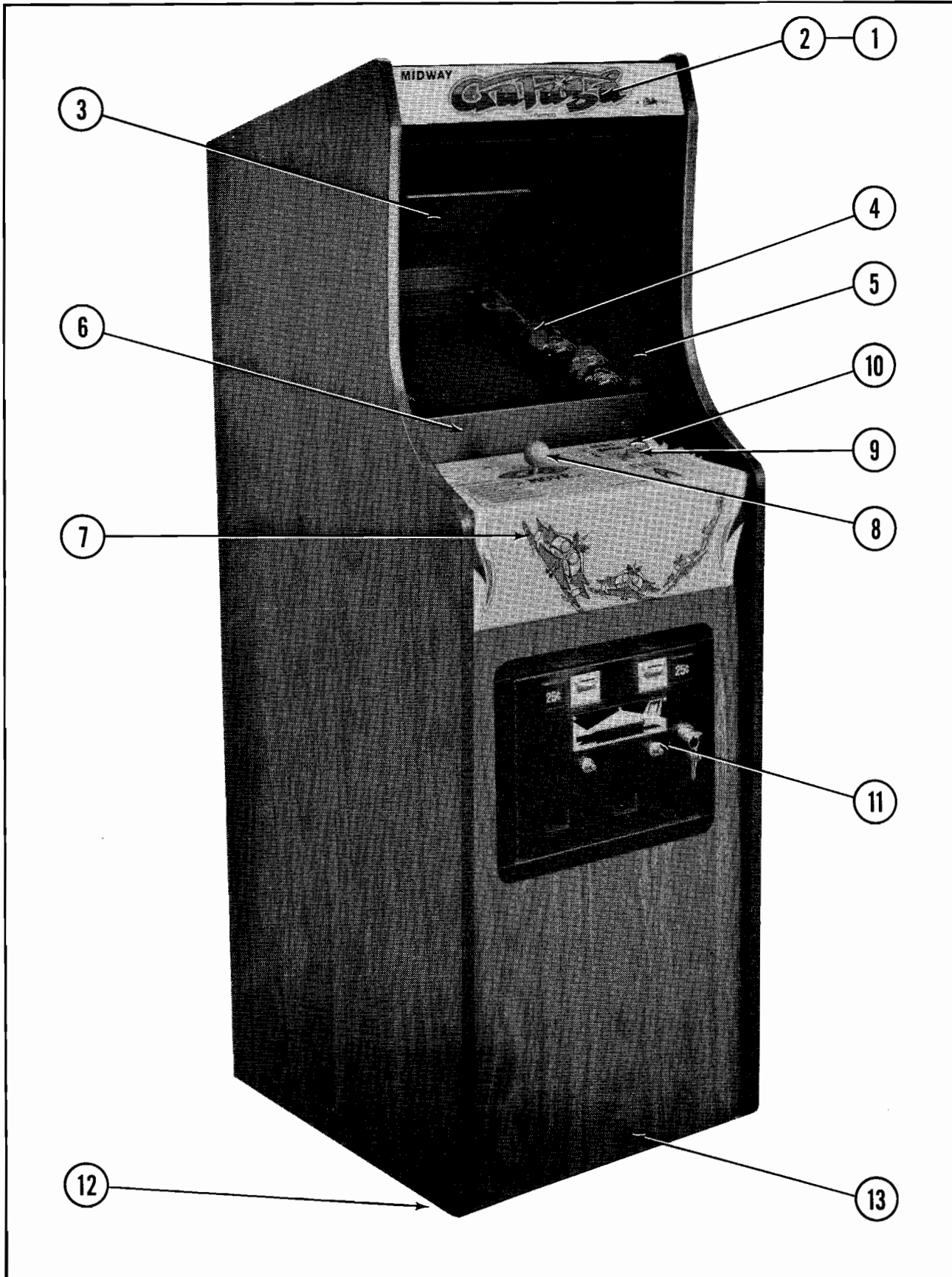

**NO. 514 — GALAGA MINI — FRONT PARTS LIST**

**ORDER BY PART NUMBER ONLY**

<b>ITEM</b>	<b>PART NO.</b>	<b>DESCRIPTION</b>
1	0514-00901-00XF 0017-00101-0138 0017-00009-0522	DISPLAY PANEL #8 x 5/8 TORX TAMPER RESISTANT SCR. (8 REQ'D.) LONG ARM KEY T-20 (FOR ABOVE SCREW)
2	A926-00010-0000 0017-00031-0030 0017-00003-0219	INSERT DISPLAY ASSY. WEDGE BASE LIGHT SOCKET (5 REQ'D.) #194 LAMP 14V., .27A. (5 REQ'D.)
3	0017-00009-0393 0017-00003-0187 0017-00101-0127 0017-00103-0061	BLACK SPEAKER GRILL W/SLOTS 6" x 9" SPEAKER 8 OHM, 9W. #8-32 x 1-1/2 CARRIAGE BOLT (4 REQ'D.) #8-32 HEX NUT W/SEMS (4 REQ'D.)
4	0514-00900-00XF	FRONT GLASS — 17-13/16" x 14-13/16" x 3/16"
5	0905-00903-0100	GLASS EDGE CHANNEL — 14-1/2 LG. (2 REQ'D.)
6	A931-00012-0000 0017-00101-0138	GLASS CLAMPING PLATE ASSY. #8 x 5/8 TORX TAMPER RESISTANT SCREW (2 REQ'D.)
7	A514-00008-0000 0514-00100-0000 0514-00902-0000 0017-00101-0620 0017-00103-0061 0514-00102-0100 0514-00102-0200 0961-00115-00XF 0017-00009-0033	CONTROL PLATE & OVERLAY ASSY. CONTROL SHELF PLATE DECORATIVE SHELF OVERLAY #8-32 x 1/2 CARRIAGE BOLT (4 REQ'D.) #8-32 HEX NUT W/SEMS (4 REQ'D.) CONTROL SHELF BRKT. SUPPORT — RIGHT CONTROL SHELF B RKT. SUPPORT — LEFT STRIKE (2 REQ'D.) BASSICK CLAMP (2 REQ'D.)
8	A508-00011-0000	CONTROL ASSY.
9	0017-00042-0256 0017-00032-0093 0017-00103-0054	PUSH BUTTON ASSY. — RED PUSH BUTTON SWITCH W/HOLDER 5/8-11 PAL NUT
10	0017-00032-0051	SMALL RED SWITCH BUTTON W/HARDWARE (2 REQ'D.)
11	A090-00300-07BK 0090-00002-02BK 0017-00101-0121	U.S.A. 25¢ COIN DOOR ASSY. LARGE COIN DOOR FRAME #6-32 x 5/16 PHIL. TRS. HD. SCR. (3 REQ'D.) (MOUNTS COIN DOOR TO FRAME)
12	0017-00102-0048 0017-00103-0026	3/8-16 x 2" LEG LEVELERS (4 REQ'D.) 3/8-16 LEG LEVELER NUTS (4 REQ'D.)
13	0935-00906-0400	KICK PLATE 17-15/16" LG. — NOT SHOWN

NO. 514 — GALAGA MINI — REAR ACCESS

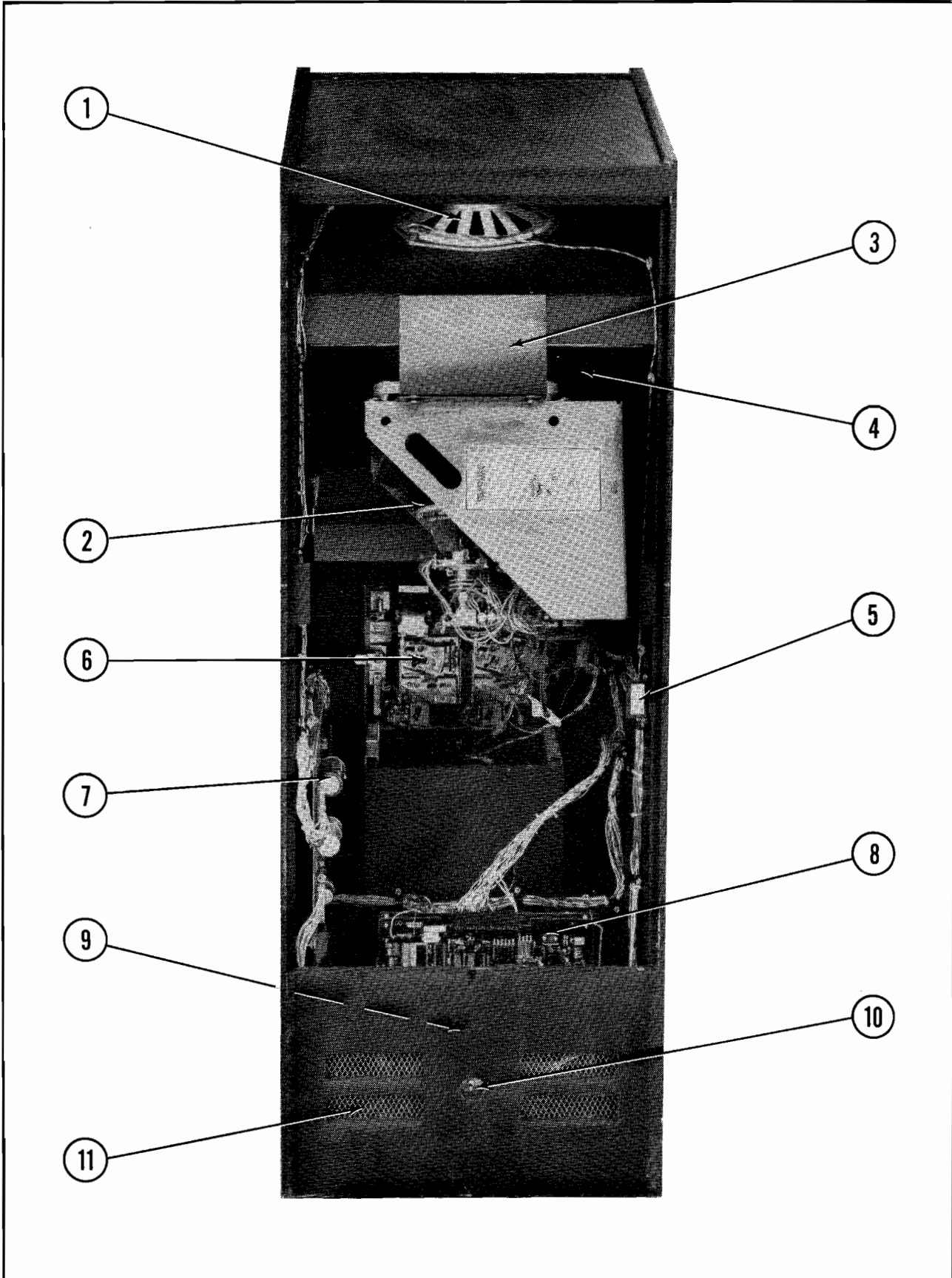

**NO. 514 — GALAGA MINI — REAR ACCESS PARTS LIST**  
**ORDER BY PART NUMBER ONLY**

ITEM	PART NO.	DESCRIPTION
1	0017-00003-0187	6" x 9" SPEAKER 8 OHM, 9W.
2	0017-00003-0340	ELECTROHOME — 13" COLOR DUAL SYNC. HORIZ. MTG. MONITOR (OR)
2	0017-00003-0369	WELLS-GARDNER — 13" COLOR DUAL SYNC. HORIZ. MTG. MONITOR
3	A926-00012-00XF	T.V. MTG. BRKT. ASSY.
	0017-00102-0066	1/4-20 x 3/4 UNSLOT. HEX HD BOLT (2 REQ'D.)
	0017-00104-0014	7/8" DISH WASHER (2 REQ'D.)
4	A514-00004-0000	T.V. BEZEL ASSY.
	0513-00900-0000	T.V. BEZEL
	0934-00905-0000	PLEXI-GLASS (TINTED)
	A961-00026-0000	BEZEL MTG. BRKT. ASSY.
5	A151-00027-0000	INTERLOCK SWITCH ASSY.
6	A090-00300-07BK	DOUBLE ENTRY COIN DOOR ASSY.
7	A084-91414-C935	POWER SUPPLY ASSY.
	0624-00902-0100	P.C. SUPPORT BRKT. — 12" LG. (2 REQ'D.)
	0624-00902-0300	P.C. SUPPORT BRKT. — 2-1/2" LG. (2 REQ'D.)
	0017-00101-0025	#8 x 1/2 SLT. HEX HD. SCR. (10 REQ'D.)
	0017-00104-0037	#8 FLAT WASHER (10 REQ'D.)
8	A508-00019-0000	CARD RACK ASSY. W/BOARDS
9	A084-91408-B508	FILTER BOARD ASSY. — NOT SEEN
	A514-00010-0000	TRANSFORMER BOARD ASSY. — (NOT SEEN) (LOCATED ON CABINET BASE)
10	A088-00013-0000	ON-OFF SWITCH & BRKT. ASSY.
11	0017-00009-0490	5-5/8" SQ. VENT GRILL (4 REQ'D.)
		<b>ADDITIONAL PARTS LIST</b>
	A097-00008-0000	BACK DOOR LOCK ASSY.
	0926-00904-0000	PROTECTIVE BUBBLE — BACK DOOR
	0017-00101-0628	#8-32 x 3/4 CARRIAGE BOLT (10 REQ'D.)
	0017-00103-0061	#8-32 HEX NUT W/SEMS (10 REQ'D.)
	A905-00028-0000	CASH BOX ASSY. W/HANDLE
	A961-00008-0000	CASH BOX COVER ASSY.
	A894-00024-0000	CASH BOX SIDE CHANNEL ASSY.
	0894-00121-0000	CASH BOX SIDE CHANNEL — LONG
	0017-00101-0628	#8-32 x 3/4 CARRIAGE BOLT (4 REQ'D.)
	0017-00104-0022	#8 FLAT WASHER (4 REQ'D.)
	0017-00103-0061	#8-32 HEX NUT W/SEMS (4 REQ'D.)
	A508-00026-0000	COIN DOOR CABLE ASSY.
	A514-00011-0000	HIGH VOLTAGE CABLE ASSY.
	A514-00012-0000	LOW VOLTAGE CABLE ASSY.
	A514-00013-0000	MASTER CABLE ASSY.
	A514-00014-0000	CONTROL SHELF CABLE ASSY.
	A514-00015-0000	DISPLAY INSERT CABLE ASSY.
	A514-00024-0000	SIGNAL CABLE ASSY.
	A508-00034-0000	AUDIO ADAPTOR CABLE ASSY.
	A508-00035-0000	MONITOR SIGNAL ADAPTOR CABLE ASSY.
	A866-00049-0000	LINE CORD ASSY.
	A082-91109-A000	CREDIT MULT. BYPASS P.C. BRD.
	3000-17143-0000	GROUND STRAP
	A082-91410-A000	RAPID FIRE P.C. BRD. ASSY.

NO. 510 — GALAGA COCKTAIL — FRONT

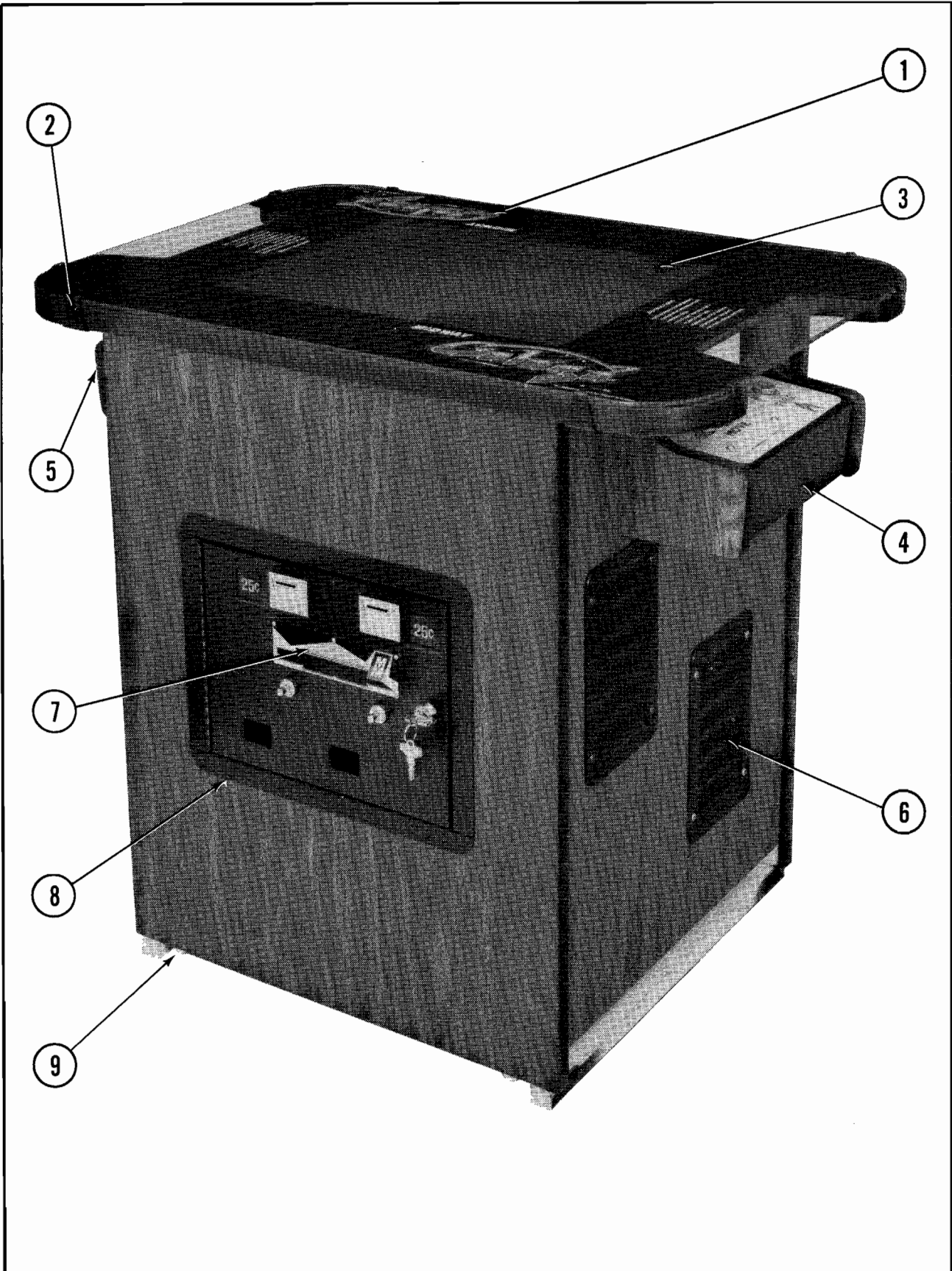

**NO. 510 — GALAGA COCKTAIL — FRONT PARTS LIST**

*ORDER BY PART NUMBER ONLY*

ITEM	PART NO.	DESCRIPTION
1	0510-00900-00XF	COVER GLASS — 32" x 22" x 1/4
2	0775-00104-00XF	GLASS CLIPS (8 REQ'D.)
	0017-00101-0117	#8 x 5/8 PHIL TRS. HD. SCR. (16 REQ'D.)
3	A927-00022-0000	T.V. BEZEL & PLEXI ASSY.
	0927-00903-0000	T.V. BEZEL
	0869-00907-0000	GREY PLEXI
4	A510-00006-0100	CONTROL SHELF ASSY. — PLAYER #2
5	A501-00006-0000	CONTROL SHELF ASSY. — PLAYER #1
6	0017-00009-0393	BLACK SPEAKER GRILL W/SLOTS (3 REQ'D.)
	0017-00003-0259	6" x 9" SPEAKER 8 OHM, 7W.
	0017-00101-0136	#8-32 x 1-1/4 CARRIAGE BOLT (12 REQ'D.)
	0017-00103-0061	#8-32 HEX NUT W/SEMS (12 REQ'D.)
7	A090-00300-06BK	DOUBLE ENTRY COIN DOOR ASSY.
8	0090-00002-02BK	LARGE COIN DOOR FRAME
	0017-00101-0121	#6-32 x 5/16 PHIL. TRS. HD. SCR. (3 REQ'D.) (MOUNTS COIN DOOR TO FRAME)
9	0017-00102-0048	3/8-16 x 2" LEG LEVELERS (4 REQ'D.)
	0017-00103-0026	3/8-16 LEG LEVELER NUTS (4 REQ'D.)
		<u>NOT SHOWN LIST</u>
	A927-00019-0000	COIN BOX ASSY.
	A962-00004-0000	COIN BOX COVER ASSY.
	A962-00005-0000	COIN BOX SIDE CHANNEL ASSY. — SHORT
	0962-00101-0000	COIN BOX SIDE CHANNEL — SHORT
	0017-00101-0628	#8-32 x 3/4 CARRIAGE BOLT (4 REQ'D.)
	0017-00104-0022	#8 WASHER (4 REQ'D.)
	0017-00103-0061	#8-32 HEX NUT W/SEMS (4 REQ'D.)
	A927-00008-0000	ON/OFF SWITCH ASSY.
	A151-00078-0000	INTERLOCK SWITCH ASSY.
	A775-00013-0000	FAN ASSY.
	0151-00081-0000	4" MUFFIN FAN
	0775-00110-00XF	FAN PLATE
	0749-00106-00XF	FAN SCREEN
	0017-00101-0347	#6-32 x 1/2 R.H.M.S. (4 REQ'D.)
	0017-00104-0009	#6 EXT. WASHER (4 REQ'D.)
	0017-00103-0005	#6-32 HEX NUT (4 REQ'D.)
	0017-00101-0026	#8 x 5/8 SLT. HEX HD. SCR. (4 REQ'D.)
	A866-00049-0000	LINE CORD ASSY.
	3000-17143-0000	GROUND STRAP
	0927-00907-0000	HIGH VOLTAGE SHIELD — FORMED



NO. 510 — GALAGA COCKTAIL — INTERIOR ACCESS

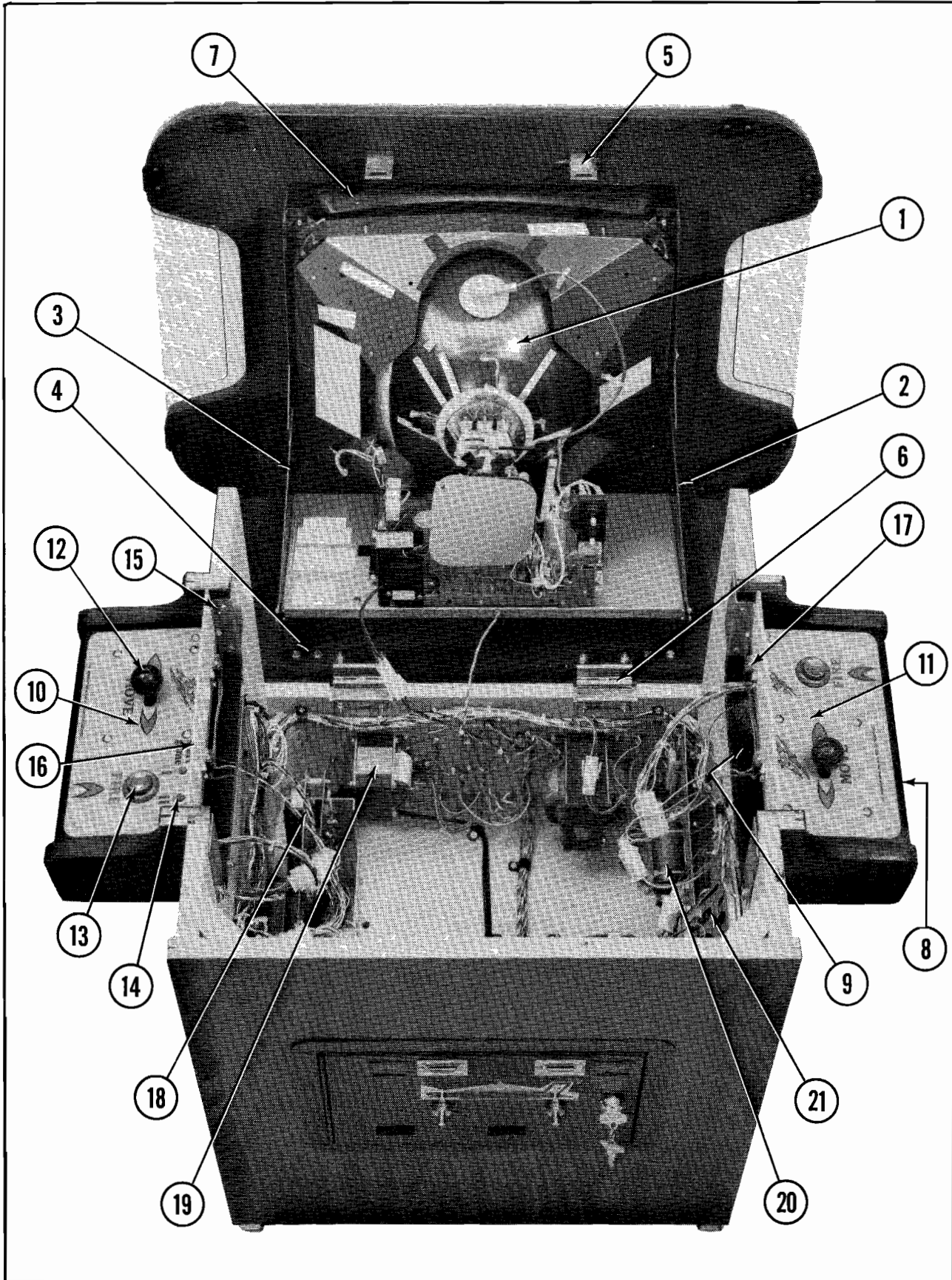

**NO. 510 — GALAGA COCKTAIL — INTERIOR ACCESS PARTS LIST  
ORDER BY PART NUMBER ONLY**

ITEM	PART NO.	DESCRIPTION
1	0017-00003-0339	ELECTROHOME — 19" COLOR DUAL SYNC. HORIZ. MTG. MONITOR
2	A515-00017-01XF	MONITOR SUPPORT ASSY. — RIGHT
3	A515-00017-02XF	MONITOR SUPPORT ASSY. — LEFT
	0017-00101-0109	#8 x 5/16 UNSLOT. HEX HD. BOLT (6 REQ'D.)
4	0927-00101-00XF	SUPPORT ANGLE (2 REQ'D.)
	0017-00101-0598	#8-32 x 5/16 SLT. HEX HD. M.S. (8 REQ'D.)
5	0610-00132-00ZN	STRIKE (2 REQ'D.)
	0017-00009-0033	BASSICK CLAMP (2 REQ'D.) — NOT SEEN
	0017-00101-0027	#8 x 3/4 SLT. HEX HD. SCREW (8 REQ'D.)
6	0017-00009-0514	2-1/2" HINGE (2 REQ'D.)
	0017-00101-0639	#8-32 x 1-1/4 CARRIAGE BOLT (4 REQ'D.)
	0017-00101-0628	#8-32 x 3/4 CARRIAGE BOLT (4 REQ'D.)
	0017-00103-0061	#8-32 HEX NUT W/SEMS (8 REQ'D.)
7	0927-00903-0000	T.V. BEZEL
8	0510-00100-00XF	CONTROL PLATE (2 REQ'D.)
9	0510-00101-00XF	BOTTOM PAN (2 REQ'D.)
10	0510-00901-0100	DECORATIVE CONTROL SHELF OVERLAY — PLAYER #1
11	0510-00901-0200	DECORATIVE CONTROL SHELF OVERLAY — PLAYER #2
	0017-00101-0620	#8-32 x 1/2 CARRIAGE BOLT (8 REQ'D.)
	0017-00103-0061	#8-32 HEX NUT W/SEMS (8 REQ'D.)
	0017-00101-0341	#6 x 1/4 PHIL. TRS. HD. SCR. (14 REQ'D.)
12	A508-00011-0000	CONTROL ASSY. (2 REQ'D.)
13	0017-00042-0256	RED PUSH BUTTON ASSY. (2 REQ'D.)
	0017-00032-0093	PUSH BUTTON SWITCH W/HOLDER (2 REQ'D.)
	0017-00103-0054	5/8-11 PAL NUT (2 REQ'D.)
14	0017-00032-0051	SMALL RED BUTTON SWITCH W/HARDWARE (2 REQ'D.)
15	0930-00104-0000	PANEL LOCATING BRKT. (4 REQ'D.)
	0017-00101-0025	#8 x 1/2 SLT. HEX HD. M.S. (20 REQ'D.)
16	0930-00904-0000	LIGHT SHIELD (2 REQ'D.)
17	0017-00031-0044	WEDGE BASE LAMP SOCKET (4 REQ'D.)
	0017-00003-0219	#194 LAMP 14V., .27A. (4 REQ'D.)
	0017-00101-0555	#6-32 x 5/16 SLT. HEX HD. M.S. (4 REQ'D.)
18	A508-00019-0000	CARD RACK ASSY. W/BOARDS
19	0510-00009-0000	TRANSFORMER BOARD ASSY.
20	A084-90414-C935	POWER SUPPLY ASSY.
	0624-00902-0100	P.C. SUPPORT BRKT. 12" LG. (2 REQ'D.)
	0624-00902-0500	P.C. SUPPORT BRKT. — 6-1/2" LG. (2 REQ'D.)
	0017-00101-0017	#6 x 1/2 SLT. HEX HD. SCR. (10 REQ'D.)
	0017-00104-0031	5/8 DIA. FLAT WASHER (10 REQ'D.)
21	0017-00003-0259	6" x 9" SPEAKER 8 OHM, 7W.
		<b>ADDITIONAL PARTS LIST</b>
	A510-00007-0000	CONTROL SHELF CABLE ASSY. — PLAYER #1
	A510-00007-0100	CONTROL SHELF CABLE ASSY. — PLAYER #2
	A510-00011-0000	HIGH VOLTAGE CABLE ASSY.
	A510-00012-0000	LOW VOLTAGE CABLE ASSY.
	A510-00013-0000	MASTER CABLE ASSY.
	A510-00014-0000	VIDEO SIGNAL CABLE ASSY.
	A508-00026-0000	COIN DOOR CABLE ASSY.
	A508-00034-0000	AUDIO ADAPTOR CABLE ASSY.
	A508-00035-0000	MONITOR SIGNAL ADAPTOR CABLE ASSY.
	A084-91408-B508	FILTER BOARD ASSY.
	A082-91109-A000	CREDIT MULT. BYPASS P.C. BRD.
	A082-91410-A000	RAPID FIRE P.C. BRD. ASSY.

# **V Technical Troubleshooting**

# Troubleshooting

## Introduction

The most common problems occur in harness components such as the coin acceptor, player controls, interconnecting wiring, etc. The TV monitor and PCB computer cause their share of problems too, but not as much as the harness and its component parts. TV monitor troubleshooting will not be covered here because it is covered in that section of this manual.

As you already know, the PCB computer is a complex device with a number of different circuits. Some circuits remain basically the same among games, but overall there are a great many differences between them. PCB troubleshooting procedures, therefore, can be lengthy and will differ greatly among games. However, some basic Z-80 CPU information is involved in this section.

## General Suggestions

The first step in any troubleshooting procedure is correctly identifying the malfunction's symptoms. This includes not only the circuits or features malfunctioning, but also those still operational. A carefully trained eye will pick up other clues as well. For instance, a game in which the computer functions fail completely just after money was collected may have a quarter shorting the PCB traces. Often, an experienced troubleshooter will be able to spot the cause of the problem even before opening the cabinet.

After all the clues are carefully considered, the possible malfunctioning areas can be narrowed down to one or two good suspects. Those areas can be examined by a process of elimination until the cause of the malfunction is discovered.

## Harness Component Troubleshooting

Typical problems falling in this category are coin and credit problems, power problems and failure of individual features.

### NO GAME CREDIT

For example, your prospective player inserts his quarter and is not awarded a game. The first item to check is if the quarter is returned. If the quarter is returned, the malfunction most certainly lies in the coin acceptor itself. First, use a set of test coins (both old and new) to ascertain that the player's coin is not undersize or underweight. If your test coins are also returned, coin acceptor servicing is indicated. Generally, the cause of this particular problem is a maladjusted magnet gate. Normally, this will mean slightly closing the magnet gate a little by turning the adjusting screw out a bit (see section on coin acceptor for more details).

If the quarter is not returned and there is no game credit, the cause of the malfunction may be in one of several areas. First try operating the coin return button; if the coin is returned, the problem is most likely in the magnet gate. Enlarge the gap according to the coin acceptor service procedures. If this does not cure the problem, remove the coin acceptor, clean it and perform the major adjustment procedure.

If the trapped coin is not returned when the wiper lever is actuated, you may have an acceptor jammed by a slug, gummed up with beer, a jammed coin chute, or mechanical failure of the acceptor mechanism. In this case, first check for the slug that will generally be trapped against the magnet. If so, simply remove the slug and test the acceptor. If the chute is blocked, remove the acceptor and remove the jammed coins. If there is actual failure of the acceptor, remove the unit and repair as indicated in the coin acceptor service procedures.

If the coin is making its way through the acceptor (that is, falling into the coin box), yet there is still no game credit, you either have a mechanical failure of the coin switch or electrical failure of the coin and credit circuits. The first place to begin is by checking the coin switch. Most of these switches are the make/break variety of micro switch, which is checked by testing for continuity between the NO, NC, and C terminals. When not actuated, the NC and C terminals should be continuous and the NO terminal open. When operated, the NO and C terminals should close and the NC should be open. If the coin switch checks out, examine the connections to the terminals to make sure there is good contact. If necessary, use the continuity tester and check from the terminal lug on the switch to the associated PCB trace. This will tell you if there is a continuous line all the way to the credit circuit.

If the coin switch wires do not check out, the problem is in the computer — most likely in the coin and credit circuitry.

If you do get game credit when a coin is deposited, but the game will not start when the start switch is pressed, you may have a problem in the start switch, the interconnecting wiring or in the computer. First check the switch. If the switch is OK, proceed to check the wiring. Again, make sure you go from the terminal lug on the switch to the PCB trace. This way, you will check the terminal contact as well as PCB edge connector contact. If the wiring is continuous, proceed to check the PCB credit circuit. If not, check each section of the wiring, until the discontinuity is located. If the wiring is OK, the problem must lie in the computer.

## Transformer and Line Voltage Problems

Your machine must have the correct line voltage to operate properly. If the line voltage drops too low, a circuit in the computer will disable game credit. The point at which the computer will fail to work will vary some from game to game, but no game will work on line voltage that drops below 105 VAC.

Low line voltage may have many causes. Line voltage normally fluctuates a certain amount during the day as the total usage varies. Peak usage times occur mainly at dawn or dusk, so if your machine's malfunction seems to be related to the time of day, this may be a factor. A large load connected to the same line as the game (such as a large air conditioner or other device with an exceptionally large motor) may drop the line voltage significantly when starting up. This drop can result in an intermittent credit problem. In addition, poor connections in the location wiring, plug, or line cord may also cause a significant drop in power. Cold solder joints in the game's harness, especially in areas like the transformer connections, interlock switch, or fuse block, may also produce the same results, although probably on a more permanent basis.

Sometimes location owners (especially in bars) replace light switches with dimmer rheostats, and the game is sometimes on the same line. Obviously, the voltage available to the game is going to drop dramatically when the dimmer is turned.

In any case, the way to check for correct line voltage is with your VOM. Set the VOM to 250 VAC and stick the probes in the wall receptacle. If it's OK here, check the transformer primary connections. If you do not get 117 VAC, examine the solder joints on the transformer, fuse block, and interlock switch. If you do get 117 VAC, the problem must be either in the transformer, harness connections, or in the PCB power supply.

If you suspect the transformer, check its secondaries with the VOM set to 50 VAC and correlate the readings with the legend on the side of the transformer. The transformer must also be correctly grounded, so check the ground potential as well, especially if there is a hum bar rolling up or down the TV screen.

### HARNESS PROBLEMS

Other harness problems include blowing fuses and malfunctioning controls. The repeating blown-fuse problem can sometimes be quite exasperating to solve, for short circuits have the tendency to occur in areas almost impossible to find. First, try inserting a new fuse, as old fuses age and blow without cause. If the new one also blows, you definitely have a short.

The best way to approach this problem is by turning the power off and disconnecting devices that may be causing the problem, such as the TV, transformer, and PCB. Disconnect the devices by pulling off their connectors, but do not allow them to touch. If necessary, insulate them with small pieces of electrical tape. Then, connect your VOM across the terminals of the fuse block (all electrical power shut off), and set it to one of the resistance scales. This will save blowing a fuse each time you want to check the circuit.

If the VOM reveals that disconnecting the devices removed the short, reconnect the devices one by one until the short returns. The last device connected is the one that is at fault. If the VOM reads a short even after the devices are disconnected, the fault must lie in the harness itself, and only patient exploration will reveal its location. First, carefully examine all the wiring, looking for terminals that may be touching, metal objects such as coins shorting connections or burned insulation. If necessary, use the VOM to check each suspected wire.

### MALFUNCTIONING CONTROLS

One of the most common problems here is a bad potentiometer. Typically, a bad pot will cause the image to jump as it reaches a certain point. The only cure for this one is to install a new pot.

If a feature that is operated by a switch (for example, joysticks, foot pedals, control panel buttons) does not operate at all, check the switch with a VOM or continuity tester to verify its operation. If the switch does not check out, replace it. If the switch is OK, you should suspect the input to the switch from the PCB. In this case, get out the harness and logic schematics and check to see what kind of input it is. In many cases, the input will be +5 VDC. If so, use the VOM to check its presence. Normally, the switch is used to pull a +5 VDC line LOW to GND or to pull a LOW line HIGH. If the PCB output is missing, check the wire length from the PCB. If you find the signal at the PCB trace, the wire length or connection is at fault. If not, begin exploring the PCB using the logic schematics.

# A Glossary of Microprocessor Terms

**MICROPROCESSOR** — one or several microcircuits that perform the function of a computer's CPU. Sections of the circuit have arithmetic and comparative functions that perform computations and executive instructions.

**CPU** — central-processing unit. A computing system's "brain", whose arithmetic, control and logic elements direct functions and perform computations. The microprocessor section of a microcomputer is on one chip or several chips.

**PROM** — programmable read-only memory. User permanently sets binary on-off bits in each cell by selectively fusing or not fusing electrical links. Non-erasable. Used for low-volume applications.

**EPROM** — erasable, programmable, read-only memory. Can be erased by ultraviolet light bath, then reprogrammed. Frequently used during design and

development to get programs debugged, then replaced by ROM for mass production.

**ROM** — read-only memory. The program, or binary on-off bit pattern, is set into ROM during manufacture, usually as part of the last metal layer put onto the chip. Nonerasable. Typical ROM's contain up to 16,000 bits of data to serve as the microprocessor's basic instructions.

**RAM** — random-access memory. Stores binary bits as electrical charges in transistor memory cells. Can be read or modified through the CPU. Stores input instructions and results. Erased when power is turned off.

**LSI** — large scale integration. Formation of hundreds or thousands of so-called gate circuits on semiconductor chips. Very large scale integration (VLS) involves microcircuits with the greatest component density.

**MOS** — metal-oxide semiconductor. A layered construction technique for integrated circuits that achieves high component densities. Variations in MOS chip structures create circuits with speed and low-power requirements, or other advantages (static will damage a MOS chip).

---

## Introduction to the Z-80 CPU

The term "microcomputer" has been used to describe virtually every type of small computing device designed within the last few years. This term has been applied to everything from simple "microprogrammed" controllers constructed out of TTL MSI up to low end minicomputers with a portion of the CPU constructed out of TTL LSI "bit slices." However, the major impact of the LSI technology within the last few years has been with MOS LSI. With this technology, it is possible to fabricate complete and very powerful computer systems with only a few MOS LSI components.

The Zilog Z-80 family of components can be configured with any type of standard semiconductor memory to generate computer systems with an extremely wide range of capabilities. For example, as few as two LSI circuits and three standard TTL MSI packages can be combined to form a simple controller. With additional memory and I/O devices a computer can be constructed with capabilities that only a minicomputer could previously deliver.

New products using the MOS LSI microcomputer are being developed at an extraordinary rate. The Zilog Z-80 component set has been designed to fit into this market through the following factors:

1. The Z-80 is fully software compatible with the popular 8080A CPU.
2. Existing designs can be easily converted to include the Z-80.
3. The Z-80 component set is at present superior in both software and hardware capabilities to any other microcomputer system on the market today.
4. For increased throughput the Z80A operating at a 4 MHz clock rate offers the user significant speed advantages.

Microcomputer systems are extremely simple to construct using Z-80 components. Any such system consists of three parts:

1. **CPU (Central Processing Unit)**
2. **Memory**
3. **Interface Circuits to peripheral devices**

The CPU is the heart of the system. Its function is to obtain instructions from the memory and perform the desired operations. The memory is used to contain instructions and in most cases data that is to be processed. For example, a typical instruction sequence may be to read data from a specific peripheral device, store it in a location in memory, check the parity and write it out to another peripheral device. Note that the Zilog component set includes the CPU and various general purpose I/O device controllers, while a wide range of memory devices may be used from any source. Thus, all required components can be connected together in a very simple manner with virtually no other external logic.

## General Purpose Registers

There are two matched sets of general purpose registers, each set containing six 8-bit registers that may be used individually as 8-bit registers or as 16-bit register pairs by the programmer. One set is called BC, DE and HL while the complementary set is called BC', DE' and HL'. At any one time the programmer can select either set of registers to work with through a single exchange command for the entire set. In systems where fast interrupt response is required, one set of general purpose registers and an accumulator/flag register may be reserved for handling this very fast routine. Only a simple exchange command need be executed to go between the routines. This greatly reduces interrupt service time by eliminating the requirement for saving and retrieving register contents in the external stack during interrupt or subroutine processing. These general purpose registers are used for a wide range of applications by the programmer. They also simplify programming, especially in ROM based systems where little external read/write memory is available.

## Arithmetic & Logic Unit (ALU)

The 8-bit arithmetic and logical instructions of the CPU are executed in the ALU. Internally the ALU communicates with the registers and the external

data bus on the internal data bus. The type of functions performed by the ALU include:

<b>Add</b>	Left or right shifts or rotates (arithmetic and logical)
<b>Subtract</b>	Increment
<b>Logical AND</b>	Decrement
<b>Logical OR</b>	Set bit
<b>Logical Exclusive OR</b>	Reset bit
<b>Compare</b>	Test bit

## Instruction Register and CPU Control

As each instruction is fetched from memory, it is placed in the instruction register and decoded. The control sections performs this function and then generates and supplies all of the control signals necessary to read or write data from or to the registers, control the ALU and provide all required external control signals.

## Z-80 CPU Pin Description

The Z-80 CPU is packaged in an industry standard 40 pin Dual In-Line Package. The I/O pins are shown in the below figure and the function of each is described.

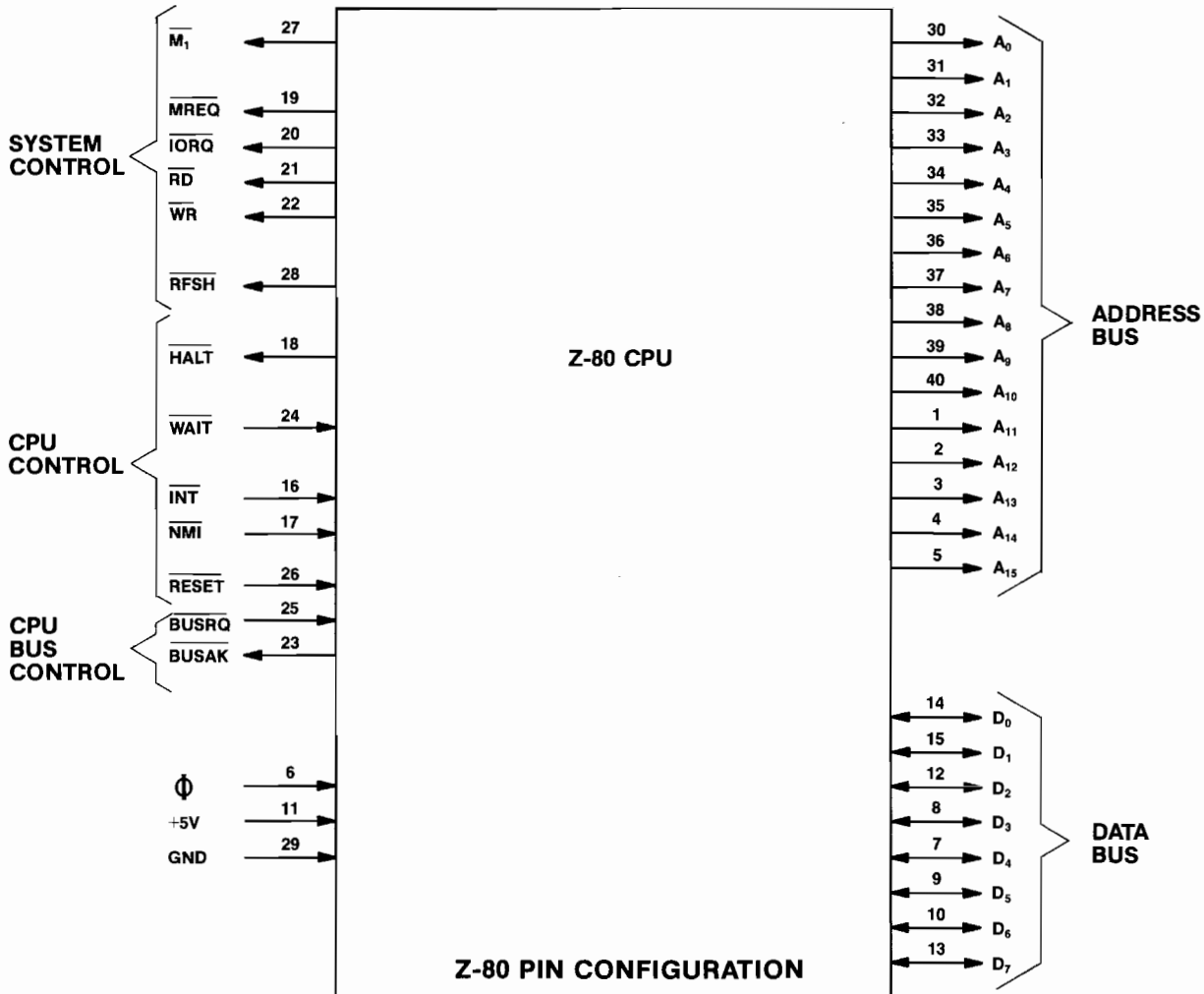



**A<sub>0</sub>-A<sub>15</sub>****(Address Bus)**

Tri-state output, active high. A<sub>0</sub>-A<sub>15</sub> constitute a 16-bit address bus. The address bus provides the address for memory (up to 64K bytes) data exchanges and for I/O device data exchanges. I/O addressing uses the 8 lower address bits to allow the user to directly select up to 256 input or 256 output ports. A<sub>0</sub> is the least significant address bit. During refresh time, the lower 7 bits contain a valid refresh address.

**D<sub>0</sub>-D<sub>7</sub>****(Data Bus)**

Tri-state input/output, active high. D<sub>0</sub>-D<sub>7</sub> constitute an 8-bit bidirectional data bus. The data bus is used for data exchanges with memory and I/O devices.

**M<sub>1</sub>****(Machine Cycle one)**

Output, active low.  $\overline{M_1}$  indicates that the current machine cycle is the OP code fetch cycle of an instruction execution. Note that during execution of 2-byte op-codes,  $\overline{M_1}$  is generated as each op code byte is fetched. These two byte op-codes always begin with CBH, DDH, EDH or FDH.  $\overline{M_1}$  also occurs with  $\overline{IORQ}$  to indicate an interrupt acknowledge cycle.

**MREQ****(Memory Request)**

Tri-state output, active low. The memory request signal indicates that the address bus holds a valid address for a memory read or memory write operation.

**IORQ****(Input/Output Request)**

Tri-state output, active low. The  $\overline{IORQ}$  signal indicates that the lower half of the address bus holds a valid I/O address for a I/O read or write operation. An  $\overline{IORQ}$  signal is also generated with an  $\overline{M_1}$  signal when an interrupt is being acknowledged to indicate that an interrupt response vector can be placed on the data bus. Interrupt Acknowledge operations occur during M<sub>1</sub> time while I/O operations never occur during M<sub>1</sub> time.

**RD****(Memory Read)**

Tri-state output, active low.  $\overline{RD}$  indicates that the CPU wants to read data from memory or an I/O device. The addressed I/O device or memory should use this signal to gate data onto the CPU data bus.

**WR****(Memory Write)**

Tri-state output, active low.  $\overline{WR}$  indicates that the CPU data bus holds valid data to be stored in the addressed memory or I/O device.

**RFSH****(Refresh)**

Output, active low.  $\overline{RFSH}$  indicates that the lower 7 bits of the address bus contain a refresh address for dynamic memories and the current MREQ signal should be used to do a refresh read to all dynamic memories.

**HALT****(Halt state)**

Output, active low.  $\overline{HALT}$  indicates that the CPU has executed a HALT software instruction and is awaiting either a non maskable or a maskable interrupt (with the mask enabled) before operation can resume. While halted, the CPU executes NOP's to maintain memory refresh activity.

**WAIT****(Wait)**

Input, active low.  $\overline{WAIT}$  indicates to the Z-80 CPU that the addressed memory or I/O devices are not ready for a data transfer. The CPU continues to enter wait states for as long as this signal is active. This signal allows memory or I/O devices of any speed to be synchronized to the CPU.

**INT****(Interrupt Request)**

Input, active low. The Interrupt Request signal is generated by I/O devices. A request will be honored at the end of the current instruction if the internal software controlled interrupt enable flip-flop (IFF) is enabled and if the  $\overline{BUSRQ}$  signal is not active. When the CPU accepts the interrupt, an acknowledge signal ( $\overline{IORQ}$  during M<sub>1</sub> time) is sent out at the beginning of the next instruction cycle. The CPU can respond to an interrupt in three different modes that are described in detail in section 5.4 (CPU Control Instructions).

**NMI****(Non-Maskable Interrupt)**

Input, negative edge triggered. The non maskable interrupt request line has a higher priority than  $\overline{INT}$  and is always recognized at the end of the current instruction, independent of the status of the interrupt enable flip-flop.  $\overline{NMI}$  automatically forces the Z-80 CPU to restart to location 0066<sub>H</sub>. The program counter is automatically saved in the external stack so that the user can return to the program that was interrupted. Note that continuous  $\overline{WAIT}$  cycles can prevent the current instruction from ending, and that a  $\overline{BUSRQ}$  will override a  $\overline{NMI}$ .

**RESET**

Input, active low. RESET forces the program counter to zero and initializes the CPU. The CPU initialization includes:

- 1) Disable the interrupt enable flip-flop



- 2) Set Register I = 00H
- 3) Set Register R = 00H
- 4) Set Interrupt Mode 0

During reset time, the address bus and data bus go to a high impedance state and all control output signals go to the inactive state.

When BUSRQ is activated, the CPU will set these buses to a high impedance state as soon as the current CPU machine cycle is terminated.

**BUSAK  
(Bus Acknowledge)**

Output, active low. Bus acknowledge is used to indicate to the requesting device that the CPU address bus, data bus and tri-state control bus signals have been set to their high impedance state and the external device can now control these signals.

Single phase TTL level clock which requires only a 330 ohm pull-up resistor to +5 volts to meet all clock requirements.

**BUSRQ  
(Bus Request)**

Input, active low. The bus request signal is used to request the CPU address bus, data bus and tri-state output control signals to go to a high impedance state so that other devices can control these buses.

**Basic Logic and Processor Books**

- 1. UNDERSTANDING SOLID STATE ELECTRONICS**  
By: Texas Instruments \$2.95  
Radio Shack \$1.95
- 2. TTL COOKBOOK**  
By: Dom Lancaster \$8.95
- 3. DIGITAL VIDEO TEXT BOOK**  
By: Kush-N. Stuff  
Wico \$14.95
- 4. BEGINNER'S GUIDE TO MICROPROCESSORS**  
By: Charles M. Gilmore  
Tab Books \$5.95
- 5. AN INTRODUCTION TO MICROCOMPUTERS**  
By: Adam Osborne \$7.50
- 6. 8080 SYSTEM USER'S MANUAL**  
By: Intel \$5.00

*Prices may vary*

**PLEASE NOTE:**

THE INFORMATION CONTAINED IN THIS SECTION  
IS TOLD IN AN EASY TO UNDERSTAND MANNER  
AND IS INTENDED TO AID THOSE WITHOUT AN  
ELECTRONICS DEGREE IN TROUBLESHOOTING AND  
REPAIRING THEIR GAMES T.V. MONITOR.

IF YOU READ THROUGH THIS SECTION AND STILL  
HAVE QUESTIONS, PLEASE CONTACT YOUR DISTRIBUTOR  
OR MIDWAY MANUFACTURING COMPANY AT THE TOLL  
FREE NUMBER PROVIDED WITH YOUR GAMES PAPERS.

**OUR STAFF AND OUR DISTRIBUTORS STAND READY  
TO HELP YOU!**

**THANK YOU**

**VI T.V. Monitor**

# Color T.V. Monitor

## **Introduction:** (How to use this section of your manual.)

This section has been designed to simply familiarize you with one of the more mystical components in your game — the T.V. monitor. If you are an electronics technician who is quite knowledgeable on the subject, you may decide to just go to the schematics and start troubleshooting the defective monitor. But if you are like most people, a monitor is a T.V. set, and that means a complex doo-dad that means big buck repairs. This isn't necessarily so. This section of the manual will acquaint you with the monitor and could just help you repair it if you feel adventurous enough to give it a try. If you have any knowledge of electronics, especially the use of a voltmeter, the repairs you can make are astonishing. Just keep in mind that **ELECTRICITY CAN BE VERY DANGEROUS, SO BE CAREFUL!!**

If you want to understand how a monitor works, just read the "THEORY OF OPERATION" subsection. If you wish, you can follow along with the schematics. The information is presented in a very basic manner but more complete treatment of the subject can be found in the technical sections of bookstores.

If you want to attempt to repair your monitor, it would be a good idea to read this whole section beginning to end before starting. **Pay attention to all warnings**

**and take them seriously.** The more equipment you have the better, but a low cost Volt-Ohm-Milliameter can often do the trick. Here are the steps to take:

1. Find the symptom that matches the problems your monitor has in the "SYSTEM — DIAGNOSIS" subsection. The diagnosis tells the circuit or area the problem may be in and possibly even the actual component causing it.
2. Once you have the circuit that is causing the trouble, read the "TROUBLESHOOTING" subsection to learn the procedure for finding the bad part.
3. Next, go to the schematic section and find the schematic that matches your monitor. It may be helpful to read the "DIFFERENCES BETWEEN MONITORS" subsection if you are unsure of which monitor you have. Use the schematic to see what parts are in the offending circuit.

That really is all there is to it. Just remember that there are some bizarre or rare symptoms not covered, or that a monitor may have two or more different problems that only a genius, the experienced, or an experienced genius can figure out. But be patient, follow safety precautions, and remember that there is also literature available from the monitor companies through your distributor or from Midway Manufacturing Company on request. (There is a toll free number on the back side of the front cover of this manual.)

# Symptom Diagnosis

- 1. Insufficient width or height:**
  - A. Horizontal line (due to VERTICAL CIRCUIT DEFECT).
    - Bad yoke.
    - Bad vertical output section.
    - Open fusible resistor in vertical section.
    - Bad height control.
    - Bad flyback.
  - B. Vertical line (due to HORIZONTAL CIRCUIT DEFECT).
    - Bad yoke.
    - Open width coil.
    - Open part in horizontal output section.
- 2. Picture spread out too far or crushed in certain areas:**
  - A. Horizontal or vertical output transistor.
  - B. Bad component in output circuitry.
- 3. Line too close with black spacing:**
  - A. Problem in vertical section causing poor linearity.
- 4. Poor focus and convergence:**
  - A. Bad high voltage transformer ("flyback") or control.
  - B. Focus voltage wire not connected to neck-board terminal.
- 5. Colors missing; check:**
  - A. Interface color transistors.
  - B. Color output transistors.
  - C. Cracked printed circuit board.
  - D. Color circuits.
  - E. Video input jack.
- 6. Picture not bright enough:**
  - A. Weak emission from picture tube. (Turn horizontal sync off frequency and put brightness all the way up for about 15 minutes. Occasionally this cures the problem.)
- 7. Silvery effect in white areas; check:**
  - A. Beam current transistors.
  - B. Weak picture tube emission.
- 8. Too much brightness with retrace lines; check:**
  - A. Beam limiter transistors.
  - B. Brightness and/or color blanking control set too high.
- 9. Increasing brightness causes an increase in size and poor focus.**
  - A. Weak high voltage rectifier or regulation (high voltage unit).
- 10. Small picture and/or poor focus:**
  - A. Low B+ voltage (power supply trouble).
- 11. Vertical rolling:**
  - A. Vertical oscillator transistor, IC, or circuit.
  - B. No sync from logic board.
- 12. Horizontal line across center:**
  - A. Vertical output circuit is dead (see symptom No. 1. A.).
  - B. Vertical oscillator is not putting out the right wave form.
- 13. Picture bends:**
  - A. Horizontal sync needs adjusting.
  - B. Magnetic or electromagnetic interference.
- 14. Flashing picture, visible retrace lines:**
  - A. Broken neck board.
  - B. Internal short circuit in the picture tube (arcing).
- 15. Unsymmetrical picture or sides of picture:**
  - A. Defective yoke.
- 16. No brightness, power supply operating — No high voltage for the picture tube; check:**
  - A. Horizontal oscillator.
  - B. Horizontal amplifier and output.
  - C. Flyback transformer (high voltage unit).
- 17. No brightness, high voltage present; check:**
  - A. Heater voltage to the tube at the neck board.
  - B. Screen-grid voltage for the tube.
  - C. Focus voltage.
  - D. Grid to cathode picture tube bias.
- 18. No high voltage; check:**
  - A. For AC input to the "flyback".
  - B. Horizontal deflection stages.
  - C. Flyback transformer.
  - D. Yoke.
  - E. Power supply.
- 19. No horizontal and vertical hold; check:**
  - A. Sync transistors and circuit.
  - B. Wires and jack from logic board to the monitor.
- 20. Wavy picture — (power supply defect); check:**
  - A. Transistors, diodes, electrolytic capacitors in the power supply.

**21. Moving bars in picture:**

- A. Ground connector off between monitor and logic boards.
- B. Defect in the power supply (see wavy picture symptom).

**22. Washed out picture (see picture not bright enough):**

- A. Check video signal at the cathode pins with an oscilloscope. If there is about 80 volts peak to peak, the picture tube has weak emission.

**23. Monitor won't turn on:**

- A. Problem in the power supply: Check fuse, transistors, open fusible resistor.
- B. Shorted horizontal output transistor.

- C. Defective high voltage disabling circuit.
- D. Crack(s) somewhere on main chassis board.

**24. Can't adjust purity or convergence:**

- A. Use a degausser to demagnetize the picture tube carefully following your degausser's instructions.
- B. Picture tube defective.
- C. Metal foreign material is in picture tube shield.
- D. Nearby equipment is electromagnetically interfering.
- E. The poles of the earth are pulling off the purity.
- F. Poor focus or width of picture.

---

---

## Guide To Schematic Symbols

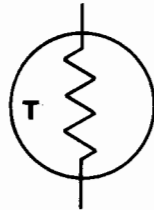

**THERMISTOR**  
(POLARITY DOESN'T MATTER)

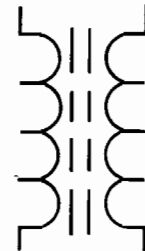

**IRON CORE TRANSFORMER**  
(SUCH AS A FLYBACK)



**INDUCTOR, COIL, CHOKE**  
(POLARITY DOESN'T MATTER)



**FUSE**  
(POLARITY DOESN'T MATTER)

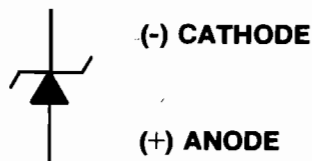

**ZENER DIODE**

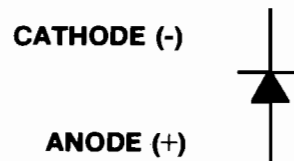

**DIODE**

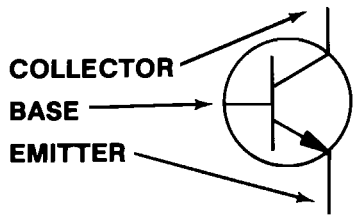

**NPN TRANSISTOR**

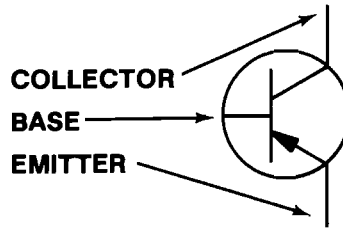

**PNP TRANSISTOR**



**VARIABLE RESISTOR, POT, CONTROL**  
(POLARITY DOESN'T MATTER)



**RESISTOR**  
(POLARITY DOESN'T MATTER)

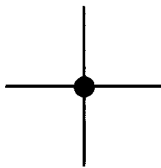

**LINES ARE CONNECTED**

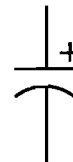

**ELECTROLYTIC CAPACITOR**

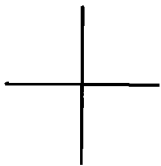

**LINES ARE NOT CONNECTED**



**CAPACITOR**  
(POLARITY DOESN'T MATTER)

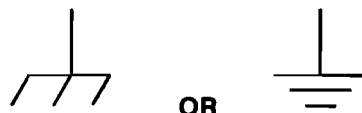

**GROUND**

# Troubleshooting

Troubleshooting monitors requires experience, patience, **and luck**. The first step is to match the symptom the monitor displays to the diagnosis next to it in the "SYMPTOM-DIAGNOSIS" subsection. This will pinpoint the circuit the problem is probably in, and often the parts to check. Next, the circuit should be visually inspected to see if there are any parts broken, burned, or if something is there that shouldn't be, like a loose screw, etc. Some parts go bad before others and should be checked first. In fact, following is the general order in which parts usually go bad:

1. Semiconductors (like transistors, diodes, and integrated circuits).
2. Fusible resistors.
3. Electrolytic capacitors.
4. Resistors.
5. Capacitors and coils.

Always remember that a monitor can bite like a snake. Even when it is turned off, capacitors hold voltage and will discharge it to you should you be touching chassis ground. The picture tube or CRT, itself, is a giant capacitor, so avoid the flyback anode plug hole. With the monitor on, the power supply circuit and/or the flyback, which puts out at least 18,000 volts, **CAN BE KILLERS!!** Avoid handling power transistors (usually output transistors), yoke terminals, and other high power components when the monitor is on.

## **WARNING: That picture tube is a bomb!**

When it breaks, first it implodes, then it explodes. Large pieces of glass have been known to fly in excess of 20 feet in all directions. **DO NOT** carry it by the long, thin neck. Discharge its voltage to ground by shorting the anode hole to ground. Use a plastic handled screwdriver, connect one end of a wire with an alligator clip at each end to chassis ground and the other end to the metal shaft of the screwdriver. Using **ONE HAND ONLY** (put the other in your pocket) and touching **ONLY** the plastic handle of the screwdriver (**DO NOT TOUCH THE METAL SHAFT**) stick the blade of the screwdriver into the anode hole. Be prepared for a fairly loud pop and a flash. The longer the monitor has been turned off, the smaller the pop and dimmer the flash. But **BE CAREFUL**, picture tubes will hold a very

healthy charge for at least **a week** if not longer. Even after you've discharged it once, it may still carry a residual charge. It's better to be too careful than dead, which is why electronic equipment always carries stickers referring servicing to qualified personnel. Handle the side with the viewing screen against your chest when changing it. **ALWAYS** wear safety goggles when handling the picture tube.

To maintain the safety and performance of the monitor, always use exact replacement parts. For instance, the wrong components in the power supply can cause a fire, or the wrong color transistor may give a funny color to the picture. Service your monitor on a nonconductive firm table like wood, **NOT METAL**, and take off all of your jewelry just in case. With all this in mind, you are ready to begin troubleshooting.

Observe the picture carefully. Try to vary the appropriate control that would most likely affect your particular symptom. For example, if there is poor brightness or no picture, try turning up the brightness or contrast control. If the controls have no effect at all, chances are there is trouble with the control itself, the circuit it controls, or a nearby circuit that may be upsetting voltages. Go to the list of symptoms and determine with the schematic where the bad circuit is.

## **CAUTION:**

**Keep in mind that capacitors hold a charge as can the picture tube (for at least a week and usually longer), and could shock you.**

First, check for obvious visual defects such as broken or frayed wires, solder where it is not supposed to be, missing components, burned components, or cracked printed circuit boards. If everything looks good up to this point, make sure that diodes, electrolytic capacitors, and transistors have their leads connected in the right polarity as shown on the schematic and the circuit board.

Turn on the power and measure the voltages at the leads of the active devices such as tubes, transistors, or integrated circuits. Any voltage that does not come within at least 10% to 15% of the voltage specified on the schematic indicates either a problem with that device or a component connected with it in the circuit. The next step is to use the ohmmeter to narrow down the field of possible offenders.

To test a transistor, one lead of the ohmmeter is placed on the base; and the other lead placed just on the emitter, then on the collector. A normal transistor will read either high resistance (infinite), or little resistance (400 to 900 ohms), depending on the polarity of this type transistor. Then the leads should be switched, one remaining on the base, and the other switched from the emitter to the collector. Now the opposite condition should result: the resistance should be infinite if it was lower when the other lead was on the base. Consistently infinite readings indicate an open, and a short is demonstrated by 0-30 ohms on most of these test readings. Finally, place one lead on the collector, then the other on the emitter. No matter which lead is used, there should be infinite resistance. Any lower reading, such as 50 ohms (which is typical on a bad transistor), indicates a short.

This all sounds pretty confusing, but a little experience on a good transistor will make you an expert in no time. Usually, the lowest ohmmeter setting is used for testing transistors. Once in a great while a transistor may check out good on this test, but may actually be "leaky" or break down only on higher voltages. If in doubt, change it. It is also wise to check the transistor out of the circuit just in case some component in the circuit is affecting the ohmmeter reading.

A diode is tested like a transistor except it only has two leads. Again, there should be high resistance one

way and little resistance the other. If it tests bad, take one lead out of the circuit in case some component is messing up the ohmmeter reading.

**NOTE: DO NOT** leave soldering equipment on the leads too long since all semiconductors, especially integrated circuits, are easily destroyed by heat.

Without special equipment, integrated circuits are checked by verifying the proper DC voltage on the pins and the correct AC wave form using an oscilloscope. **BE CAREFUL:** Shorting their pins can easily destroy them.

Resistors are checked with an ohmmeter and should usually be within ten percent of the value stated on them and on the schematic. You may have to desolder one lead from the printed circuit board. If you wreck the foil on the board, carefully solder a small wire over the break to reconnect the conductive foil.

Capacitors are tricky. Their resistance goes up when checked with an ohmmeter which shows a charging action. As they suck up current from the meter, the voltage goes up and so does the resistance. If you are sure a particular circuit is giving you a problem and everything else checks out O.K., Electrolytic capacitors are prime suspects. Substitute a new one and keep your fingers crossed.

---

---

## Theory of Operation

To understand what goes on inside the monitor, large general groups of circuits will be examined instead of laboriously analyzing the branches and small circuits that make up these groups. This will help avoid confusion and aid in a basic, concrete, knowledge of what makes up a monitor.

### THE POWER SUPPLY —

The AC going to the monitor from the game transformer is just like the voltage and current from your wall outlet. It jumps up and down going positive and negative sixty times a second. But a monitor needs nice, smooth DC; direct current, not alternating. So diodes chop up the AC and a big electrolytic capacitor filters it out to make it even smoother. Since the monitor is a big piece of electronic equipment, with many circuits demanding a lot of power from the power supply, there are also zener diodes and transistors to help maintain a nice, constant, smooth voltage so that the monitor circuits don't jump around. And this is what happens when you see a wavy picture. There is AC creeping

through the power supply, so it must be malfunctioning. If the voltage from the power supply is too low, the other circuits will be starved for power and you may see a small, wavy picture, or none at all.

Some circuits receive voltages that are higher than what the power supply should put out. But they come from the flyback transformer which will be discussed later.

### THE INTERFACE SECTION OF THE CHASSIS —

The interface section of the chassis is fairly easy to identify. It is right by the place where the video jack(s) from the logic board(s) plug into. There are sets of transistors that receive the separate red, green, blue, and sync information from the cables that come from the logic boards. The circuits jack up the voltage and match impedances, or in other words, prepare the logic board outputs for the circuits that will really amplify them for the output devices such as the yoke in the case of the sync, or the picture tube that shows the colors.



An interesting aside is that our sync is composite negative sync. That means two things:

1. The sync is a negative going wave form.
2. There are two pulses going at different speeds over the same wire:
  - a. Vertical wave forms at 60 times per second (or Hertz) and
  - b. Horizontal wave forms at about 15,750 times per second (Hz).

The sync is amplified by a sync amplifier transistor and sent on its way to the oscillators. The sync or timing information will be explained along with the oscillator shortly.

The color information is sent via wires to the neck board where the main amplification occurs. This will also be discussed later.

## **VERTICAL AND HORIZONTAL DEFLECTION —**

After the sync signal is amplified by the sync amp, it goes to two different sections, the vertical and horizontal circuits. Basically, the sync signals are for timing so the picture doesn't mess up since it is assembled like an orderly jigsaw puzzle, but so fast that you can't see the electron beams for each color painting the picture on the screen. This will all become clear soon. For now, we will follow the 60 cycle component of the sync as it goes on its journey to the deflection yoke.

The 60 cycle pulse goes to the vertical oscillator to make sure this circuit goes back and forth (or oscillates) at 60 times a second. Without this pulse keeping the circuit at the correct speed, it may get lazy and oscillate at 58 cycles or lower, or get ambitious and oscillate at 62 cycles or higher. At the wrong speed, the picture will start to roll up or down.

A Wells Gardner 13" or 19" color monitor uses transistors for its sync section. An Electrohome 13" or 19" color monitor uses an integrated circuit IC501 for its sync section. The idea is all the same. The output to the vertical amplifying transistors for all monitors must be a sawtooth wave form, sort of like a bunch of pyramids, racing to the yoke's vertical coils at 60 times a second.

Along the way to the output transistors, the 60 cycle pulse is shaped and amplified to do the job: the yoke magnetically pushes the electron beam to fill the screen out sideways looking at the screen with the greatest length going up and down. Or viewing the screen sitting like a home television set. The amplified vertical output fills the screen up and down. Watching a monitor like this, seeing only a horizontal line means a problem with the vertical coils of the yoke or anything from the vertical output section on back to the oscillator.

The horizontal section is very similar with a few exceptions. The horizontal wave shape is more like a square and has a frequency of 15,750 cycles a second. Again, Wells Gardner uses transistors for the horizontal oscillator, and Electrohome uses the other side of IC501. Still, the effect is the same. If the oscillator isn't going at the correct speed, the picture may move sideways, start to slant, or tear up with slanted thin figures. With both the vertical and horizontal of all monitors, there are variable resistors that change the speed of the oscillators up and down. This way you have controls that can make the correct frequencies to keep the electronic jigsaw puzzle nicely locked in place. If you're driving in a car and next to you someone else is driving their car at exactly the same speed, it will appear that they are not moving. And this is why the sync frequency and the oscillators frequencies must match, so the picture doesn't appear to move.

The correct wave form is shaped and amplified in the circuitry just like in the vertical section. But the horizontal output transistor is a large power transistor and not only serves to give current to the horizontal yoke windings, it also feeds the flyback transformer.

## **THE FLYBACK TRANSFORMER (OR HIGH VOLTAGE UNIT) —**

The picture tube needs high voltage to light up, and the power supply can't meet this demand. The flyback transformer receives current alternating at about 15,750 times per second from the horizontal output transistor. The "flyback" jacks up its input voltage and puts out a higher voltage alternating at the same speed. But, in your "flyback" there are diodes that chop up the alternating voltage to make it a smooth DC output just like in the power supply. This is what goes through that thick red wire to your picture tube. **THIS AREA HAS ABOUT 18,000 VOLTS ON IT AND IT CAN KILL YOU!!**

The "flyback" may be dangerous, but it is also generous. It has extra output windings which give voltage to the heater pins of the picture tube, voltage for the vertical deflection circuits, and picture tube screen-grid voltage. So in a way, the high voltage "flyback" is like a second power supply.

## **COLOR CIRCUITS**

The color circuits are pretty straight forward. The signals go into the interface section where some amplification and impedance matching occurs. These circuits are pretty sparse and simple. Each color just has two transistors and a diode with some resistors and capacitors. From here, the AC color signal is sent by wires to the neck board.

The color output circuits are on the neck board. The color signals going to the transistors are controlled by two variable resistors called drive controls. There only two, one for the red and one for the green. The

blue doesn't have one. In the emitter part of each transistor is another variable resistor that is the cut off control. These controls vary the amount of amplified AC signal that goes to the cathodes of the picture tube. The more signal, the more color. The bases of each of these transistors are connected together and are all connected to the blanking and beam limiting transistors which are in the interface section.

The beam limiter helps control the brightness level, and the blanking transistor rapidly turns the picture tube on and off so that retrace lines don't show up on the screen. By turning up the brightness on a good monitor, these four to six retrace lines can be seen slanting diagonally across the picture.

### PROTECTION CIRCUIT —

To protect the high voltage section against voltages that are too high coming from the power supply which could cause X-rays to be emitted from the "flyback", a circuit senses the higher power supply voltage, and using a transistor, turns off the horizontal oscillator. Since the horizontal oscillator doesn't work, the horizontal output transistor has nothing to feed the "flyback" which in turn has nothing to feed the picture tube. The monitor will be silent, have no picture, and will appear to be off. **But don't be fooled.** There is still that excessive amount of voltage coming from the power supply. To find out, check the emitter on TR502 of the Wells Gardner monitors; or the emitter of X04 for the Electrohome monitor. Here are the voltages you should receive:

Wells Gardner = 127VDC  
Electrohome = 120VDC

The best place to measure this voltage on an Electrohome monitor is at a pin marked B1 on the chassis. This is because a 13 inch color Electrohome

monitor, the G07-FB0 or G07-902, has an integrated circuit and very little else in the power supply. Still, there should be 120VDC at B1.

### THE PICTURE TUBE (OR CRT) —

The picture tube or CRT is an output device. In other words, the end result of the circuits work is displayed by this part. Actually, the output of other circuits is in the neck of the picture tube.

First, there is the heater. The heater boils off electrons from the cathodes so that they (the electrons) shoot up to the screen to excite the phosphors so that the three phosphors emit three colors of light.

The cathodes are next, and again they emit electrons to turn on the tube phosphors, making it glow. The cathode can arc or short to the heater resulting in no picture and a defective picture tube.

Next come the grids. The first grid is grounded. The following grid is the screen grid which receives about 300VDC depending on the brightness setting. The next grid closest to the picture tube screen is the focus grid which gets about one fifth the amount of voltage that is applied to the picture tube anode.

After jetting from the cathode through all these grids, the electrons speed through a mask, a sheet of material with tiny holes, and then excite the tiny dots of phosphor in the inside surface of the picture tube screen. The green electron gun (or cathode and circuitry) spits out electrons which head for the green phosphors only. The same goes for the red and blue guns. The way the phosphor light blends determines the color seen. Should these electron beams become too intense, they may burn the phosphor. With the monitor off, this can be seen as a dark permanent image of the video information on the tube screen.

---

## Differences Between Monitors

The easiest way to identify the brand of monitor you are working with, assuming you can't find the brand name written on it anywhere, is to see if there are two circuit boards rising up from the chassis toward the picture tube neck. In other words, they stand up, or are perpendicular to the chassis, with a black plastic bracket holding them in place. This is a description of a Wells Gardner monitor. They use separate boards for main chunks of circuitry. Therefore, you have a "power board" (the power supply), an "interface board" (the interface section), and a "horizontal/vertical board" (for the deflection circuitry). Still, there are a few parts on the chassis, but most can be found on the board. An Electrohome monitor has no

separate boards, except for the neck board, and just has a flat chassis.

Another good way to determine which monitor you have is to check the transistor call out numbers that are printed on the chassis next to the part. For instance, on the neck board, one of the color output transistors is TR401. If you look through the schematics or the parts lists, you will find TR401 in the Wells Gardner literature. On the other hand, the neck board transistor may say X101. X101 can be found in the Electrohome literature. So, all Wells Gardner transistor call outs begin with TR, and Electrohome transistor call outs start with an "X".

# Parts Interchangeability

Some parts can be interchanged on all of the monitors. Here are the rules:

1. You **CAN** swap the voltage regulator TR502 or X01 on any Wells Gardner or Electrohome 19 inch monitor. You **CAN NOT** swap the voltage regulator on the 13 inch Wells Gardner or Electrohome (G07-902) since the Electrohome uses an integrated circuit for the power supply.
2. You **CAN** swap any resistor between monitors that has the same resistance, wattage rating, and tolerance.
3. You **CAN** swap any capacitor between monitors that has the same capacitance, and voltage rating.
4. You **CAN** swap any 19 inch picture tube on the monitors.
5. You **CAN NOT** change any part that is a **safety part**, one that is shaded in gray on the schematic; it **MUST** be **IDENTICAL** to the original. **To do otherwise IS DANGEROUS.** For instance, the 13 inch Electrohome (G07-904) monitor "flyback" looks identical to the 19 inch Electrohome (G07-904) monitor "flyback". In fact, there is even a 19 inch Electrohome (G07-905) monitor (which is an obsolete model) with a similar looking "flyback". **NONE OF THESE ARE INTERCHANGEABLE!!**
6. You **CAN** change any of the parts between the G07-904 and G07-907. They're essentially the same monitor except that the G07-907 has a vertically mounted picture tube.

If there is any doubt about what parts can be swapped between each manufacturer's 19 inch and 13 inch models, compare the manufacturer's part number between each one. If they match up, they are the same part.

---

WELLS-GARDNER 19" COLOR MONITOR SCHEMATIC DIAGRAM

# M051-00087-A012

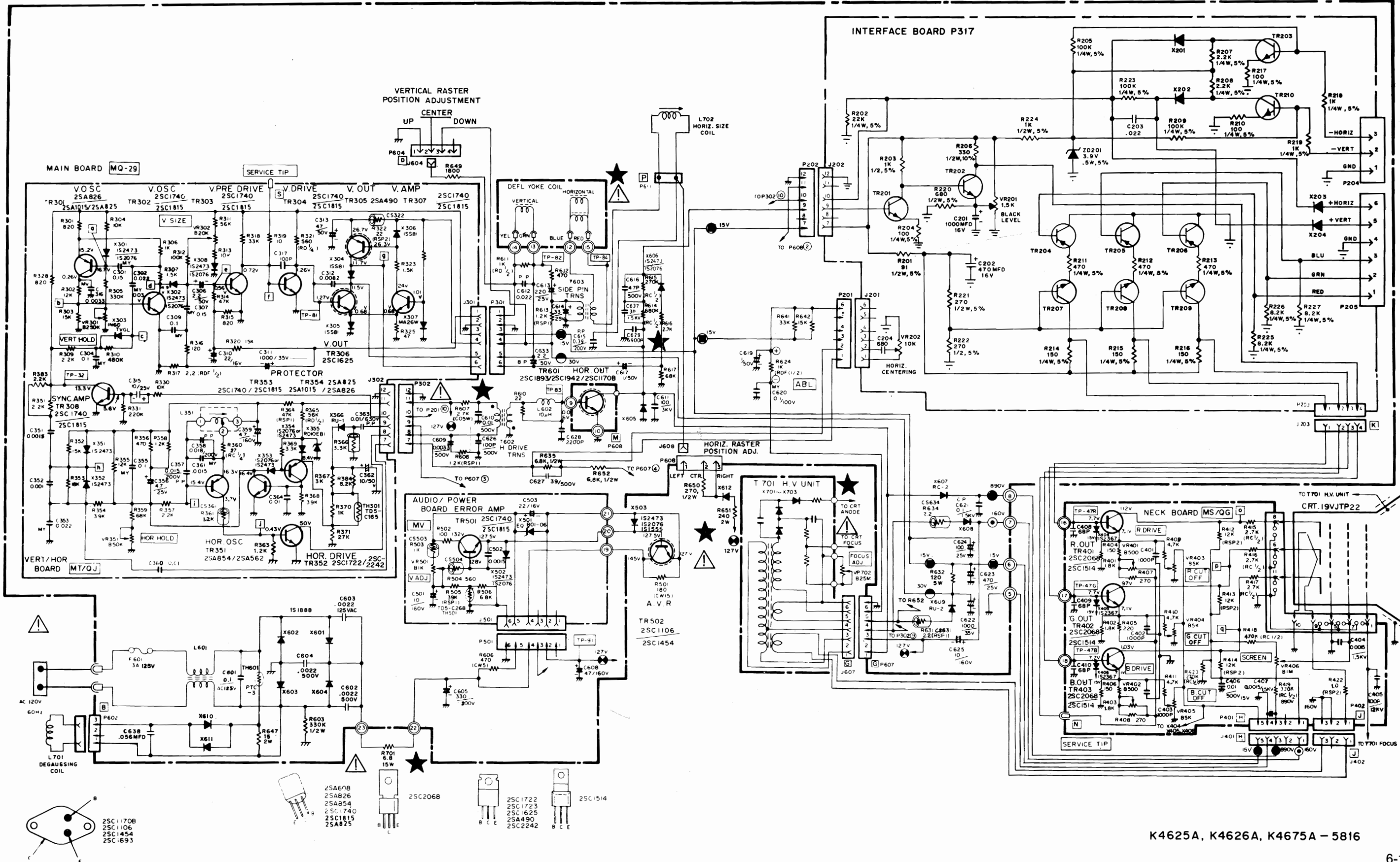

## VERT/HOR BOARD (MT/QJ)

Ref. No.	Part No.	Description	Ref. No.	Part No.	Description
<b>RESISTORS</b>			<b>CAPACITORS (CONT.)</b>		
R301	203X6500-628	820 Ohm, ± 5%, 1/8W Carbon	C313	203X0025-087	47 uF, 50V Electrolytic
R302	203X6500-902	12k Ohm, ± 5%, 1/8W Carbon	C315	203X0015-082	10 uF, 25V Electrolytic
R303	203X6500-927	15k Ohm, ± 5%, 1/8W Carbon	C316	203X1100-220	3300 uF, 50V, ± 10% Mylar
R304	203X6500-886	10k Ohm, ± 5%, 1/8W Carbon	C317	202X8000-616	100 pF, 50V, ± 10% Ceramic
R305	203X6501-241	330k Ohm, ± 5%, 1/8W Carbon	C351	202X7000-281	1500 pF, 50V, ± 10% Ceramic
R306	203X6500-645	1k Ohm, ± 5%, 1/8W Carbon	C352	202X7000-247	1000 pF, 50V, ± 10% Ceramic
R307	203X6500-689	1.5k Ohm, ± 5%, 1/8W Carbon	C353	203X1100-573	0.022 uF, 50V, ± 10% Mylar
R309	203X6500-724	2.2k Ohm, ± 5%, 1/8W Carbon	C355	203X1100-858	0.1 uF, 50V, ± 10% Mylar
R310	203X6501-285	470k Ohm, ± 5%, 1/8W Carbon	C356	203X0015-105	4.7 uF, 25V Electrolytic
R311	203X6501-065	56k Ohm, ± 5%, 1/8W Carbon	C357	203X1201-013	0.015uF, 200V ± 10% PP
R312	203X6501-126	100k Ohm, ± 5%, 1/8W Carbon	C358	203X1201-034	0.018 uF, 200V, ± 10% PP
R313	203X6001-326	10k Ohm, ± 5%, 1/8W Carbon	C359	203X0040-013	4.7 uF, 160V Electrolytic
R314	203X6501-044	47k Ohm, ± 5%, 1/8W Carbon	C360	202X7000-482	0.01 uF, 50V, ± 10% Ceramic
R315	203X6500-628	820 Ohm, ± 5%, 1/8W Carbon	C361	203X1100-509	0.015 uF, 50V, ± 10% Mylar
R316	203X6500-420	120 Ohm, ± 5%, 1/8W Carbon	C362	203X0025-058	10 uF, 50V Electrolytic
R317	203X6206-441	2.2 Ohm, ± 5%, 1/2W Carbon	C363	203X1205-487	0.01 uF, 630V, ± 10% PP
R319	203X6500-169	100 Ohm, ± 5%, 1/8W Carbon	C364	202X7000-482	0.01 uF, 50V, ± 10% Ceramic
R320	203X6500-927	15k Ohm, ± 5%, 1/8W Carbon	<b>SEMICONDUCTORS</b>		
R321	203X6700-509	560 Ohm, ± 5%, 1/2W Carbon	TR301	200X4082-614	Transistor, 2SA826Q
R322	203X9100-121	22 Ohm, ± 5%, 2W M.O.	TR302	200X3174-006	Transistor, 2SC1740Q
R323	203X6500-689	1.5K Ohm, ± 5%, 1/8W Carbon	TR303	200X3174-006	Transistor, 2SA1740Q
R324	203X6500-988	27k Ohm, ± 5%, 1/8W Carbon	TR304	200X3174-006	Transistor, 2SC1740Q
R325	203X6500-326	47 Ohm, ± 5%, 1/8W Carbon	TR305	200X4049-081	Transistor, 2SA490YLBGLI
R328	203X6500-628	820 Ohm, ± 5%, 1/8W Carbon	TR306	200X3162-538	Transistor, 2SC1625YLBGLI
R330	203X6500-886	10k Ohm, ± 5%, 1/8W Carbon	TR307	200X3174-014	Transistor, 2SC1740R
R331	203X6501-209	220k Ohm, ± 5%, 1/8W Carbon	TR308	200X3174-006	Transistor, 2SC1740Q
R351	203X6500-724	2.2k Ohm, ± 5%, 1/8W Carbon	TR351	200X4085-415	Transistor, 2SA854Q
R352	203X6500-927	15k Ohm, ± 5%, 1/8W Carbon	TR352	200X3172-208	Transistor, 2SC1722BKS
R353	203X6500-944	18k Ohm, ± 5%, 1/8W Carbon	TR353	200X3174-006	Transistor, 2SC1740Q
R354	203X6500-783	3.9k Ohm, ± 5%, 1/8W Carbon	TR354	200X4082-614	Transistor, 2SA826Q
R355	203X6500-902	12k Ohm, ± 5%, 1/8W Carbon	X301	201X2010-144	Diode, (SI) IS2473-T72
R356	203X6500-561	470 Ohm, ± 5%, 1/8W Carbon	X302	201X2010-144	Diode, (SI) IS2473-T72
R357	203X6500-724	2.2k Ohm, ± 5%, 1/8W Carbon	X303	200X8000-026	Diode, (GE), IN60TVGL
R358	203X6500-666	1.2k Ohm, ± 5%, 1/8W Carbon	X304	200X8010-165	Diode (SI) ISS81
R359	203X6501-088	68k Ohm, ± 5%, 1/8W Carbon	X305	201X2010-165	Diode (SI) ISS81
R360	203X5500-471	27 Ohm, ± 5%, 1/4W Comp.	X306	201X2010-165	Diode (SI) ISS81
R361	203X6000-998	1.2k Ohm, ± 5%, 1/8W Carbon	X307	200X8010-102	Diode (SI) MA26W
R363	203X6500-666	1.2k Ohm, ± 5%, 1/8W Carbon	X308	200X8010-094	Diode (SI) IS2473
R364	203X9014-988	47k Ohm, ± 5%, 1W M.O.	X351	201X2010-144	Diode (SI) IS2473-T72
R365	203X6700-989	56k Ohm, ± 5%, 1/2W Carbon	X352	201X2010-144	Diode (SI) IS2473-T72
R366	203X6001-148	3.3k Ohm, ± 5%, 1/8W Carbon	X353	201X2010-144	Diode (SI) IS2473-T72
R367	340X2222-734	2.2k Ohm, ± 5%, 1/2W Carbon	X354	201X2010-144	Diode (SI) IS2473-T72
R368	203X6500-785	3.9k Ohm, ± 5%, 1/8W Carbon	X355	200X8220-851	Diode (Zener) RD10EBI
R369	203X6500-762	3.3k Ohm, ± 5%, 1/4W Carbon	X366	200X8100-130	Diode (HS) RU-1 0.3 US
R370	302X6100-961	1k Ohm, ± 5%, 1/4W Carbon			
R371	203X6104-751	2.7k Ohm, ± 5%, 1/4W Carbon			
VR301	204X2122-093	Varistor, 250K Ohm, Vert. Hold			
VR302	204X2114-065	Varistor, 20K Ohm, Vert. Size			
VR351	204X2114-059	Varistor, 50K Ohm, Hor. Hold			

### CAPACITORS

C301	203X1100-928	0.15 uF, 50V, ± 10% Mylar
C302	203X1100-573	0.022 uF, 50V, ± 10% Mylar
C304	203X1100-858	0.1 uF, 50V, ± 10% Mylar
C306	203X0025-026	2.2 uF, 50V, Electrolytic
C307	203X1100-928	0.15 uF, 50V, ± 10% Mylar
C309	203X1100-858	0.1 uF, 50V, ± 10% Mylar
C310	203X0010-011	22 uF, 16V Electrolytic
C311	203X0020-099	1000 uF, 35V Electrolytic
C312	202X7000-469	0.0082 uF, 50V, ± 10% Ceramic

## POWER BOARD (MV)

### RESISTORS

R501	204X1725-052	180 Ohm, ± 10%, 15W WW
R502	203X6000-608	100 Ohm, ± 5%, 1/8W Carbon
R503	203X6000-960	1k Ohm, ± 5%, 1/8W Carbon
R504	203X6000-879	560 Ohm, ± 5%, 1/8W Carbon
R505	203X9014-965	39k Ohm, ± 5%, 1W M.O.
R506	203X6500-842	6.8k Ohm, ± 5%, 1/8W Carbon
R551	203X6500-420	120 Ohm, ± 5%, 1/8W Carbon
VR501	204X2050-001	Varistor Vert. Adj.

### CAPACITORS

C501	203X0040-020	10 uF, 160V Electrolytic
C502	202X7000-281	1500 pF, 50V, ± 10% Ceramic

C503	203X0010-011	22 uF, 16V Electrolytic
C551	203X0005-046	220 uF, 10V Electrolytic

### SEMICONDUCTORS

TR501	200X3174-006	Transistor, 2SC1740Q
★ TR502	200X3145-404	Transistor, 2SC1454
TR551	200X3172-305	Transistor, 2SC1723
X501	201X2230-042	Diode, (SI) Zener EQB01-06V
X502	201X2010-144	Diode, (SI) IS2473-T72

### MISCELLANEOUS

J501	204X9300-958	Socket, 6 Pin
P501	204X9601-195	Plug, 6 Pin
TH501	201X0000-618	Thermistor



## NECK BOARD (MS/QG)

Ref. No.	Part No.	Description	Ref. No.	Part No.	Description
<b>RESISTORS</b>					
R401	203X6500-709	1.8k Ohm ± 5% 1/8W Carbon	C403	202X7000-247	1000 pF, 50V, 10% Ceramic
R402	203X6500-709	1.8k Ohm ± 5% 1/8W Carbon	C404	202X7110-019	1500 pF, 2kV ± 10% Ceramic
R403	203X6500-709	1.8k Ohm ± 5% 1/8W Carbon	C405	202X7150-018	100 pF, 12kV, ± 10% Ceramic
R404	203X6500-447	150 Ohm ± 5% 1/8W Carbon	C406	202X7050-483	.01 uF, 500V, ± 10% Ceramic
R405	203X6500-481	220 Ohm ± 5% 1/8W Carbon	C407	202X7110-019	1500 pF, 2kV ± 10% Ceramic
R406	203X6500-447	150 Ohm ± 5% 1/8W Carbon	C408	202X8000-550	68 pF, 50V, ± 10% Ceramic
R407	203X6500-508	270 Ohm ± 5% 1/8W Carbon	C409	202X8000-550	68 pF, 50V, ± 10% Ceramic
R408	203X6500-508	270 Ohm ± 5% 1/8W Carbon	C410	202X8000-550	68 pF, 50V, ± 10% Ceramic
R409	203X6500-800	4.7k Ohm ± 5% 1/8W Carbon			
R410	203X6500-800	4.7k Ohm ± 5% 1/8W Carbon			
R411	203X6500-800	4.7k Ohm ± 5% 1/8W Carbon			
R412	203X9104-809	12k Ohm ± 5% 2.0W Metal Oxide			
R413	203X9104-809	12k Ohm ± 5% 2.0W Metal Oxide			
R414	203X9104-809	12k Ohm ± 5% 2.0W Metal Oxide			
R415	203X5601-313	2.7k Ohm ± 10% 1/2W Comp.	TR401	200X3206-800	Transistor, 2SC2068, 2SC1514 (R output)
R416	203X5601-313	2.7k Ohm ± 10% 1/2W Comp.	TR402	200X3206-800	Transistor, 2SC2068, 2SC1514 (G output)
R417	203X5601-313	2.7k Ohm ± 10% 1/2W Comp.	TR403	200X3206-800	Transistor, 2SC2068, 2SC1514 (B output)
R418	203X5602-254	470k Ohm ± 10% 1/2W Comp.			
R419	203X5602-185	330k Ohm ± 10% 1/2W Comp.	X404	201X2100-126	Diode, IS2367 (protector)
R422	203X9105-117	1.0 Ohm ± 10% 2W Metal Oxide	X405	201X2100-126	Diode, IS2367 (protector)
R423	203X5102-155	270k Ohm ± 5% 1/4W Carbon	X406	201X2100-126	Diode, IS2367 (protector)
VR401	204X2115-014	500 Ohm Varistor R Drive			
VR402	204X2115-014	500 Ohm Varistor B Drive			
VR403	204X2115-006	5k Ohm Varistor R Cutoff			
VR404	204X2115-006	5k Ohm Varistor G Cutoff			
VR405	204X2115-006	5k Ohm Varistor B Cutoff			
VR406	204X2000-025	1M Ohm Varistor Screen			

### SEMICONDUCTORS

### MISCELLANEOUS

<b>CAPACITORS</b>					
C401	202X7000-247	1000 pF, 50V, 10% Ceramic	J401	206X5003-729	Socket, 5 Pin
C402	202X7000-247	1000 pF, 50V, 10% Ceramic	J402	206X5003-983	Socket, 3 Pin
			P401	204X9600-329	Plug, 5 Pin
			P402	204X9600-254	Plug, 3 Pin

### ▲★ 297X2000-072 HIGH VOLTAGE ASSEMBLY (T701)

▲★ R701	204X1625-058	3.3 Ohm, ± 10% 10W WW Resistor	} Part of T701
VR702	204X3901-125	Focus Control	
X701		Diode (SI HV)	
X702		Diode (SI HV)	
X703		Diode (SI HV)	

### FINAL ASSEMBLY PARTS

▲★ 88X-0129-506	19VJTP22 Pix Tube
38A5554-000	Assy. Purity Shld/Degaussing
205X9800-256	Lateral/Purity Assembly
▲★ 202X1110-810	Yoke, Deflection
208X2000-946	CRT Socket
297X2000-072	HV Unit (T701)
6A0397	Plug, Line Cord
9A2753-003	Degaussing Coil (L701)

## INTERFACE BOARD (P305)

(MODEL 19K4606)

RESISTORS			SEMICONDUCTORS		
R201	340X3910-934	91 Ohm, 5%, 1/2W Carbon	TR201	86X0121-001	Transistor (NPN)
R203	340X3102-934	1k Ohm, 5%, 1/2W Carbon	TR202	86X0121-001	Transistor (NPN)
R204	340X2101-934	100 Ohm, 5%, 1/4W Carbon	TR203	86X0121-001	Transistor (NPN)
R206	340X3331-944	330 Ohm, 10%, 1/2W Carbon	TR204	86X0066-001	Transistor (PNP)
R207	340X3102-934	1k Ohm, 5%, 1/2W Carbon	TR205	86X0066-001	Transistor (PNP)
R208	340X2152-934	1.5k Ohm, 5%, 1/4W Carbon	TR206	86X0066-001	Transistor (PNP)
R209	340X2101-934	100 Ohm, 5%, 1/4W Carbon	TR207	86X0121-001	Transistor (NPN)
R210	340X3102-934	1k Ohm, 5%, 1/2W Carbon	TR208	86X0121-001	Transistor (NPN)
R211	340X2331-934	330 Ohm, 5%, 1/4W Carbon	TR209	86X0121-001	Transistor (NPN)
R212	340X2331-934	330 Ohm, 5%, 1/4W Carbon	ZD201	66X0040-018	Diode, Zener, 6.8v, 5%, 0.5W
R213	340X2331-934	330 Ohm, 5%, 1/4W Carbon	ZD202	66X0040-019	Diode, Zener, 3.9v, 5%, 0.5W
R214	340X2201-934	200 Ohm, 5%, 1/4W Carbon			
R215	340X2201-934	200 Ohm, 5%, 1/4W Carbon			
R216	340X2201-934	200 Ohm, 5%, 1/4W Carbon			
VR201	40X0590-017	1.5k Ohm, Black Level Control			
<b>CAPACITORS</b>					
C201	45X0524-038	1000 uF, 16V Electrolytic	J201	204X9300-958	Socket, 6 Pin
			J202	204X9300-958	Socket, 6 Pin
			J203	206X5019-207	Socket, 4 Pin
			P201	204X9601-195	Plug, 6 Pin
			P202	204X9601-195	Plug, 6 Pin
			P203	204X9600-845	Plug, 4 Pin
			P205	6A0393-006	Plug, 6 Pin

### MISCELLANEOUS

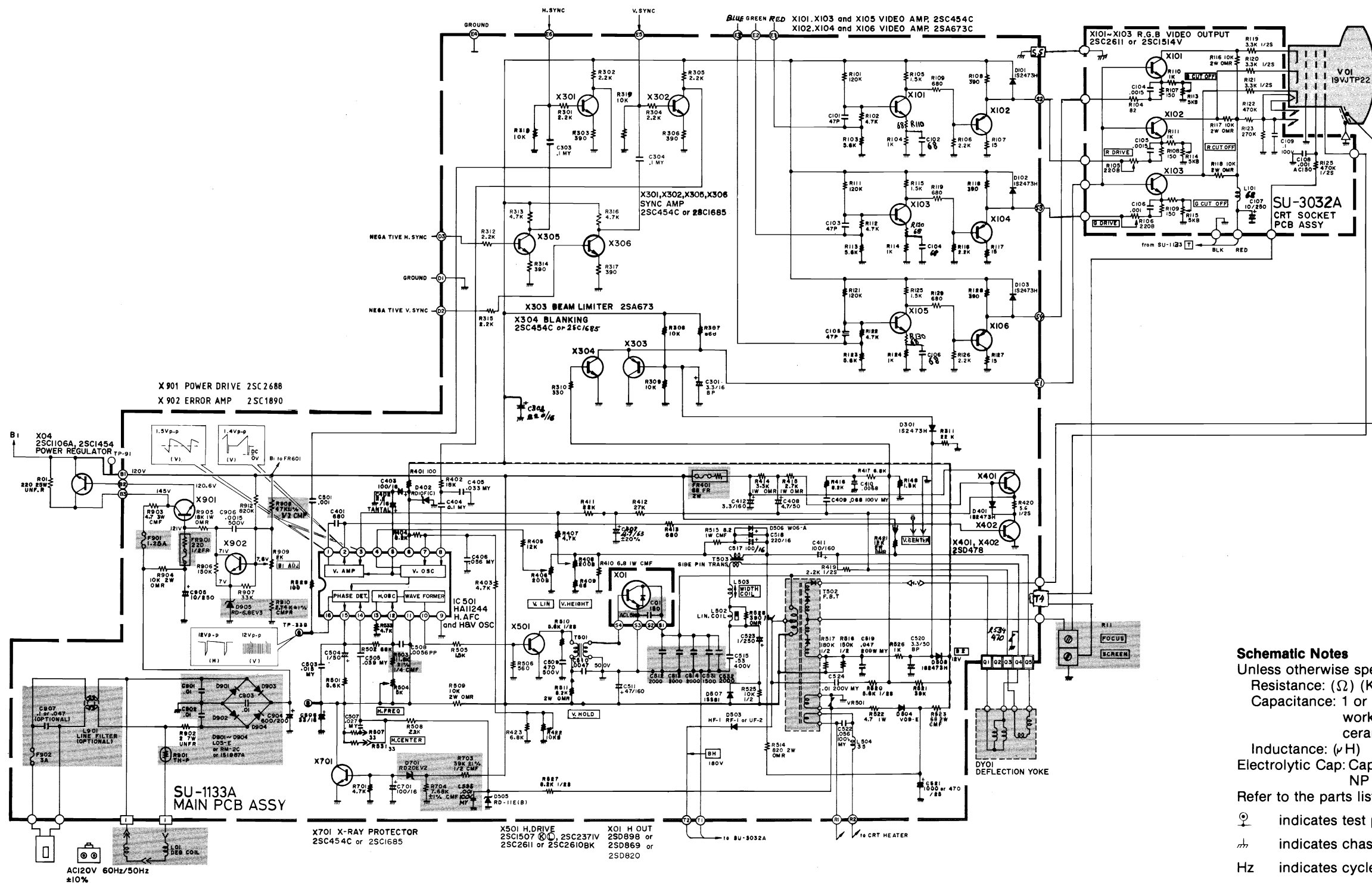

**Schematic Notes**  
 Unless otherwise specified  
 Resistance: (Ω) (K→KΩ, M→MΩ), 1/4 (W) carbon resistor  
 Capacitance: 1 or higher→ (pF), less than 1→ (μF)  
 working voltage → 50 (V)  
 ceramic capacitor  
 Inductance: (μH)  
 Electrolytic Cap: Capacitance Value (μF)/working voltage (V),  
 NP → non-polar (or bipolar) electrolytic cap.  
 Refer to the parts list for additional component information.

⊙ indicates test point connection  
 ⏏ indicates chassis ground unless otherwise specified  
 Hz indicates cycles per second

For **safety** purposes (and continuing reliability)  
 ⚠ replace all components marked with safety symbol with identical type.  
 NOTE: FR → fusible resistor (——)

00-4147-04  
 G07-CB0

Parts identification on circuit boards:  
 e.g. SU1126A (R107 = R1107)  
 SU3030A (R113 = R3113)

## REPLACEMENT PARTS LIST - ELECTROHOME 19" MONITOR

Components identified by the  $\Delta$  symbol in the PARTS LIST and on the Schematic have special characteristics important to safety.

DO NOT degrade the safety of the set through improper servicing.

### Abbreviations for Resistors and Capacitors

#### Resistor

C R	: Carbon Resistor
Comp. R	: Composition Resistor
OM R	: Oxide Metal Film Resistor
V R	: Variable Resistor
MF R	: Metal Film Resistor
CMF R	: Coating Metal Film Resistor
UNF R	: Nonflammable Resistor
F R	: Fusible Resistor

#### Capacitor

C Cap.	: Ceramic Capacitor
M Cap	: Mylar Capacitor
E Cap.	: Electrolytic Capacitor
BP E Cap.	: Bi-Polar (or Non-Polar) Electrolytic Capacitor
MM Cap.	: Metalized Mylar Capacitor
PP Cap.	: Polypropylene Capacitor
MPP Cap.	: Metalized PP Capacitor
PS Cap	: Polystyrol Capacitor
Tan. Cap.	: Tantal Capacitor

NOTE: When ordering replacement parts please specify the part number as shown in this list including part name, and model number. Complete information will help expedite the order.

Use of substitute replacement parts which do not have the same safety characteristics as specified, may create shock, fire or other hazards. For maximum reliability and performance, all parts should be replaced by those having identical specifications.

## SERVICE REPLACEMENT PARTS LIST

Symbol	Description	Part Number
	Main P.C.B. Ass'y	SU-1133A
	CRT Socket P.C.B. Ass'y	SU-3032A
	Purity Shield Ass'y	07-220083-03



### Outside of the P.C.B. Ass'y

Symbol	Description	Part Number
△	Picture Tube 19"	17-7198-03
△	△Deflection Yoke	A29779-D = 21-141-01
△	PC Magnet	A75034-B = 29-32-01
△	△Flyback Transf.	A29951-B
△	△HVR	A46600-A
R05	UNF Resistor 220Ω,25W K	QRF258K-221
C04	C Capacitor 150pF, AC1.5KV	QCZ0101-005
X01	Si. Transistor	2SD870
X02	Si. Transistor	2SC1106A
SC	Screw #8- <sup>3</sup> / <sub>8</sub>	31-610818-06
SC	Screw ¼ x ¾ Pix Tube Mtg. (4)	31-601418-12
WA	Pyramidal Lock Washer (4)	33-255-01
	Nut Retainer, Pix Tube Mtg. (4)	33-494-01
	Clip — P.C.B. Support	33-629-02
	Standoff	33-670-010R-02
	Wire Terminal (Gnd. Strap)	34-228-03
	Terminal Lug (Gnd.)	34-33-04
	Groundstrap Assy.	34-574-02
	Grounding Spring	35-212-03
	Wire Hook (Gnd. Strap)	35-3053-02
	Purity Shield Holddown Clamp	35-2348-01
	Support Brkt. RH	35-3890-01
	Support Brkt. LH	35-3890-02
	Chassis Base	38-449-02
	Yoke Wedge (3)	39-1233-01

### Purity Shield Ass'y. Parts List

Symbol	Description	Part Number
D911, D912	Degaussing Coil	21-1007-30
	Rectifier 1 Amp 600V (2)	28-22-27
	Pin Terminal (2)	34-708-01
	Pin Terminal Housing	34-709-01
	Purity Shield (2 pcs.)	35-3847-01
	Purity Shield (2 pcs.)	35-3847-02
C911	Capacitor 100nF 10% 400V	48-171544-62
R921	Resistor, Wirewound 33Ω, 4W	42-113301-03
	Fire Retardent Term. Strip 4 Lug	34-492-09

### CRT Socket P.C.B. Ass'y (SU-3032A) Parts List

#### Resistors

Symbol	Description	Part Number
R3105	V R 200	QVZ3234-022
R3106	V R 200	QVZ3234-022
R3113	V R 5K	QVZ3234-053
R3114	V R 5K	QVZ3234-053
R3115	V R 5K	QVZ3234-053
R3116	OM R 10KΩ2W J	QRG029J-103
R3117	OM R 10KΩ2W J	QRG029J-103
R3118	OM R 10KΩ2W J	QRG029J-103
R3119	Comp. R 3.3KΩ½W K	QRZ0039-332
R3120	Comp. R 3.3KΩ½W K	QRZ0039-332
C3121	Comp. R 3.3KΩ½W K	QRZ0039-332

#### Capacitors

Symbol	Description	Part Number
C3107	E Cap. 10uF 250V A	QEW53EA-106
C3108	C Cap. 1000pF DC1400V P	QCZ9001-102M

#### Coils

Symbol	Description	Part Number
L3101	Peaking Coil	QQL043K-101

**Semiconductors**

Symbol	Description	Part Number
X3101	Si. Transistor	2SC1514VC
X3102	Si. Transistor	2SC1514VC
X3103	Si. Transistor	2SC1514VC

**Miscellaneous**

Symbol	Description	Part Number
△	△CRT Socket	A76068

**Main PCB Ass'y (SU-1133A) Parts List****Resistors**

Symbol	Description	Part Number
R1406	V R 200Ω	QVZ3230-002
R1408	V R 200Ω	QVZ3230-002
R1410	CMF R 6.8Ω1W J	QRX019J-6R8
R1414	OM R 3.3KΩ1W J	QRG019J-332
R1415	OM R 2.7KΩ1W J	QRG019J-272
R1421	OM R 12KΩ2W J	QRG026J-123Z
R1422	V R 10KΩ	QVZ3230-014
△FR1401	△F R 68Ω2W K	QRH024K-680M
△R1503	△CMF R 11.8KΩ¼W +1%	QRV142F-1182
R1504	V R 5KΩ	QVZ3230-053
R1509	OM R 10KΩ2W J	QRG026J-103Z
R1512	OM R 8.2KΩ2W J	QRG026J-822Z
R1514	OM R 820Ω2W J	QRG026J-821Z
R1515	CMF R 8.2Ω1W J	QRX019J-8R2
R1522	CMF R 4.7Ω1W J	QRX019J-4R7
R1523	OM R 68Ω2W J	QRG026J-680Z
R1528	OM R 390Ω1W J	QRG019J-391
R1534	ZN R	ERZ-C05ZK471
VR1501	ZN R	ERZ-C05DK271
△R1703	△CMF R 39Ω½W +1%	QRV122F-3902
△R1704	△CMF R 7.68KΩ¼W +1%	QRV142F-7681
△R1901	△Posistor	A75414
R1902	UNF R 2Ω7W K	QRF076K-2R0
R1903	CMF R 4.7Ω3W J	QRX039J-4R7
R1904	OM R 10KΩ2W J	QRG026J-103Z
R1905	OM R 18KΩ1W J	QRG019J-183
△Q1908	△CMF R 47Ω½W +1%	QRV122F-470Z
△R1909	V R 2KΩ	QVP5A0B-023E
R1910	△CMF R 2.74KΩ¼W +1%	QRV142F-274I
△FR1901	△F R 220Ω½W K	QRH124K-221M

**Capacitors**

Symbol	Description	Part Number
C1301	BPE Cap. 3.3uF 50V A	QEN61HA-335Z
C1402	Tan. Cap. 2.2uF 16V K	QEE51CK-225B
C1407	E Cap. 4.7uF 6.3V A	QEW51JA-475
C1411	E Cap. 100uF 160V A	QEW52CA-107
C1412	E Cap. 3.3uF 160V A	QEW52CA-335
C1508	PP Cap. 5600uF 50V J	QFP31HJ-562
△C1512	△PP Cap. 2000pF DC1500V J	QFZ0082-202
△C1513	△PP Cap. 2000pF DC1500V J	QFZ0082-202
△C1514	△PP Cap. 2000pF DC1500V J	QFZ0082-202
C1515	PP Cap. 0.53uF DC1200V J	QFZ0067-534
C1520	BPE Cap. 3.3uF 50V A	QEN61HA-335Z
C1523	E Cap. 1uF 160V A	QEW62CA-105Z
C1524	M Cap. 0.1uF 200V K	QFM720K-104M
△C1531	△PP Cap. 2000pF DC1500V J	QFZ0082-202
△C1532	△PP Cap. 1500pF DC1500V J	QFZ0082-152
C1904	E Cap.	QEY0034-001
C1905	E Cap. 10uF 250V A	QEW52EA-106

<b>Coils</b>		
<b>Symbol</b>	<b>Description</b>	<b>Part Number</b>
L1502	Linarity Coil	A39835
L1503	Width Coil	C30380-A
L1504	Heater Choke	C30445-A
<b>Transformers</b>		
<b>Symbol</b>	<b>Description</b>	<b>Part Number</b>
T1501	Hor. Drive Transf.	A46022-BM
T1503	Side Pin Transf.	C39050-A
<b>Semiconductors</b>		
<b>Symbol</b>	<b>Description</b>	<b>Part Number</b>
IC1501	IC	HA11244
X1101	Si. Transistor	2SC1685(R)
X1102	Si. Transistor	2SA673(C)
X1103	Si. Transistor	2SC1685(R)
X1104	Si. Transistor	2SA673(C)
X1105	Si. Transistor	2SC1685(R)
X1106	Si. Transistor	2SA673(C)
X1301	Si. Transistor	2SC1685(R)
X1302	Si. Transistor	2SC1685(R)
X1303	Si. Transistor	2SA673(C)
X1304	Si. Transistor	2SC1685(R)
X1305	Si. Transistor	2SC1685(R)
X1401	Si. Transistor	2SD478
X1402	Si. Transistor	2SD478
X1501	Si. Transistor	2SC2610BK
X1901	Si. Transistor	2SC2688 (K.L.M.)
X1902	Si. Transistor	2SC1890A (E.F.)
D1101	Si. Diode	W06A
D1102	Si. Diode	W06A
D1103	Si. Diode	W06A
D1301	Si. Diode	1SZ473H
D1401	Si. Diode	1SZ473H
D1402	Zener Diode	RD10F(C)
D1503	Si. Diode	HF-1
D1504	Si. Diode	V09E
D1505	Zener Diode	RD11E(B)
D1506	Si. Diode	W06A
D1507	Si. Diode	1SS81
D1508	Si. Diode	1SZ473H
△D1701	△Zener Diode	RD20EV2
△D1901	△Si. Diode	1S1887A
△D1902	△Si. Diode	1S1887A
△D1903	△Si. Diode	1S1887A
△D1904	△Si. Diode	1S1887A
△D1905	△Zener Diode	RD6.8EV3
<b>Miscellaneous</b>		
<b>Symbol</b>	<b>Description</b>	<b>Part Number</b>
△F1901	△Fuse 1.25A	QMF53U1-1R25S
△F1902	△UL Fuse 3A	QMF66U1-3R0S

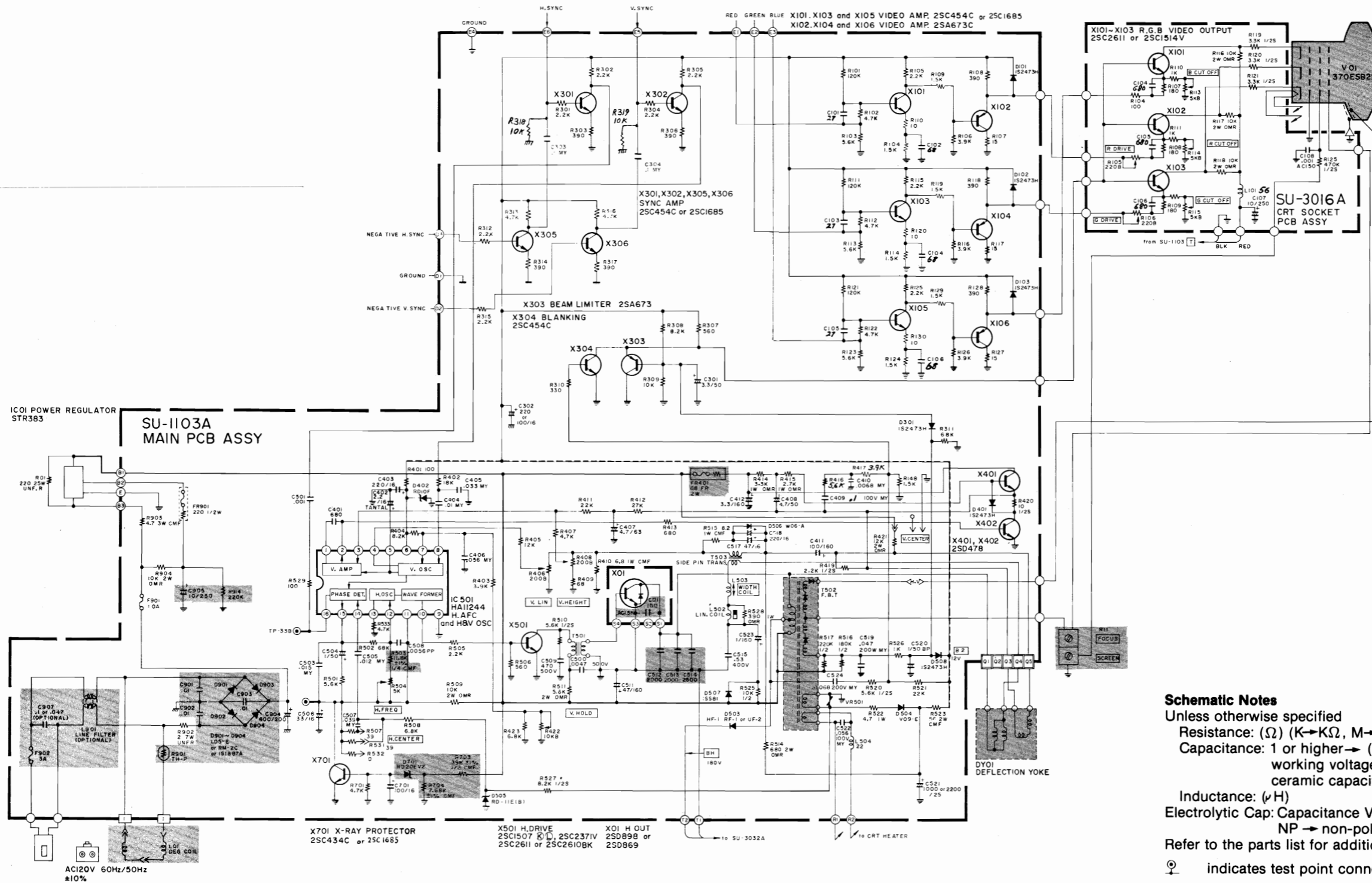

**Schematic Notes**  
 Unless otherwise specified  
 Resistance: ( $\Omega$ ) (K $\rightarrow$ K $\Omega$ , M $\rightarrow$ M $\Omega$ ), 1/4 (W) carbon resistor  
 Capacitance: 1 or higher  $\rightarrow$  (pF), less than 1  $\rightarrow$  ( $\mu$ F)  
 working voltage  $\rightarrow$  50 (V)  
 ceramic capacitor  
 Inductance: ( $\mu$ H)  
 Electrolytic Cap: Capacitance Value ( $\mu$ F)/working voltage (V),  
 NP  $\rightarrow$  non-polar (or bipolar) electrolytic cap.  
 Refer to the parts list for additional component information.  
 $\odot$  indicates test point connection  
 $\perp$  indicates chassis ground unless otherwise specified  
 Hz indicates cycles per second  
 For **safety** purposes (and continuing reliability)  
 $\triangle$  replace all components marked with safety symbol with identical type.  
 NOTE: FR  $\rightarrow$  fusible resistor ( $\rightarrow$   $\leftarrow$ )

G07-FBO  
 00-4147-03

Parts identification on circuit boards:  
 e.g. SU1126A (R107 = R1107)  
 SU3030A (R113 = R3113)

# REPLACEMENT PARTS LIST - ELECTROHOME 13" MONITOR

Components identified by the  $\Delta$  symbol in the PARTS LIST and on the Schematic have special characteristics important to safety.

DO NOT degrade the safety of the set through improper servicing.

## Abbreviations for Resistors and Capacitors

### Resistor

C R	: Carbon Resistor
Comp. R	: Composition Resistor
OM R	: Oxide Metal Film Resistor
V R	: Variable Resistor
MF R	: Metal Film Resistor
CMF R	: Coating Metal Film Resistor
UNF R	: Nonflammable Resistor
F R	: Fusible Resistor

### Capacitor

C Cap.	: Ceramic Capacitor
M Cap	: Mylar Capacitor
E Cap.	: Electrolytic Capacitor
BP E Cap.	: Bi-Polar (or Non-Polar) Electrolytic Capacitor
MM Cap.	: Metalized Mylar Capacitor
PP Cap.	: Polypropylene Capacitor
MPP Cap.	: Metalized PP Capacitor
PS Cap	: Polystyrol Capacitor
Tan. Cap.	: Tantal Capacitor

NOTE: When ordering replacement parts please specify the part number as shown in this list including part name, and model number. Complete information will help expedite the order.

Use of substitute replacement parts which do not have the same safety characteristics as specified, may create shock, fire or other hazards. For maximum reliability and performance, all parts should be replaced by those having identical specifications.

Symbol	Description	Part Number
	Main P.C.B. Ass'y	SU-1103A
	CRT Socket P.C.B. Ass'y	SU-3016A

### Outside of the P.C.B. Ass'y

Symbol	Description	Part Number
$\Delta$ V01	$\Delta$ Picture Tube	370ESB22(E)
$\Delta$ DY01	$\Delta$ Deflection Yoke	C29123-V
	PC Magnet	A76366-A
	Wedge	C30006
	$\Delta$ Flyback Transf.	A19183-A
	$\Delta$ Focus V R	A46606-A
$\Delta$ R11	UNF Resistor 220 $\Omega$ , 25W. K	QRF258K-221
$\Delta$ R05		
$\Delta$ C04	$\Delta$ C Capacitor 150 pF, AC1.5KV	QCZ0101-005
X01	Si. Transistor	2SD869
IC01	IC Regulator	STR383
L01	Degaussing Coil	21-1007-31
	Degaussing Coil Pin Terminal (2)	34-708-01
	Degaussing Coil Pin Terminal Housing	34-709-01
	Groundstrap Ass'y.	34-697-04
	Groundstrap Wire Terminal	34-228-03
	Groundstrap Spring (2)	35-3560-01
BR	Support Bracket RH	35-3919-01
BR	Support Bracket LH	35-3919-02
SC	SCREW 10- $\frac{1}{2}$ Pix Tube Mtg. (4)	31-631018-08
WA	Pyramidal Lockwasher (4)	33-255-01
	Clip P.C.B. Support (2)	33-629-02
	Ground Lug	34-33-04
CH	Chassis Base	38-452-01

## Main P.C.B. Ass'y (SU-1103A) Parts List

### Resistors

Symbol	Description	Part Number
R1406	V R 200Ω	QVZ3230-022
R1408	V R 200Ω	QVZ3230-022
R1410	CMF R 6.8Ω1W J	QRX019J-6R8
R1414	OM R 3.3KΩ1W J	QRG019J-332
R1415	OM R 2.7KΩ1W J	QRG019J-272
R1421	OM R 12KΩ2W J	QRG029J-123
R1422	V R 10KΩ	QVZ3224-014H
△FR1401	△F R 68Ω2W K	QRH024K-680M
△R1503	△CMF R 11.8KΩ¼W +1%	QRV142F-1182
R1504	V R 5KΩ	QVZ3230-053
R1509	OM R 10KΩ2W J	QRG029J-103
R1511	OM R 5.6KΩ2W J	QRG029J-562
R1514	OM R 680Ω2W J	QRG029J-681
R1515	CMF R 8.2Ω1W J	QRX019J-8R2
R1522	CMF R 4.7Ω1W J	QRX019J-4R7
R1523	OM R 56Ω2W J	ORG029J-560
R1528	OM R 390Ω1W J	ORG019J-391
R1534	ZN R	ERZ-C05ZK471
VR1501	ZN R	ERZ-C05DK271
△R1703	△CMF R 39KΩ½W +1%	QRV122F-3902
△R1704	△CMF R 7.68KΩ¼W +1%	QRV142F-7681
△R1901	△Posistor	A75414
R1902	UNF R 2Ω7W K	QRF076K-2R0
R1903	CMF R 5.6Ω3W J	QRX039J-5R6
R1904	OM R 10KΩ2W J	QRG026J-103Z
△FR1901	△F R 220Ω½W K	QRH124K-221M

### Capacitors

Symbol	Description	Part Number
C1402	Tan. Cap. 2.2uF 16V K	QEE51CK-225B
C1411	E Cap. 100uF 160V A	QEW52CA-107
C1412	E Cap. 3.3uF 160V A	QEW52CA-335
C1508	PP Cap. 5600pF 50V J	QFP31HJ-562
C1511	E Cap. 47uF 160V A	QEW52CA-476S
△C1512	△PP Cap. 2000pF DC1500V J	QFZ0082-202
△C1513	△PP Cap. 2000pF DC1500V J	QFZ0082-202
△C1514	△PP Cap. 2500pF DC1500V J	QFZ0082-252
C1515	PP Cap. 0.53uF DC1200V K	QFZ0067-534
C1520	BPE Cap. 1uF 50V A	QEN61HA-105Z
C1524	M Cap. 0.1uF 200V K	QFM72DK-682M
C1904	E Cap.	QEY0034-001
C1905	E Cap. 10uF 250V A	QEW52EA-106
△C1907	△MM Cap. 0.1uF AC150V Z	QFZ9008-104

### Coils

Symbol	Description	Part Number
L1501	Peaking Coil	A75360-6
L1502	Liniarty Coil	A39934
L1503	Width Coil	C30380-A
L1504	Heater Choke	C30333-A
L1901	Line Filter	A39475-J

### Transformers

Symbol	Description	Part Number
T1501	Hor. Drive Transf.	A46022-BM
T1503	Side Pin Transf.	C39050-A

<b>Semiconductors</b>		
<b>Symbol</b>	<b>Description</b>	<b>Part Number</b>
IC1501	I.C.	HA11244
X1101	Si. Transistor	2SC1685(R)
X1102	Si. Transistor	2SA673(C)
X1103	Si. Transistor	2SC1685(R)
X1104	Si. Transistor	2SA673(C)
X1105	Si. Transistor	2SC1685(R)
X1106	Si. Transistor	2SA673(C)
X1301	Si. Transistor	2SC1685(R)
X1302	Si. Transistor	2SC1685(R)
X1303	Si. Transistor	2SA673(C)
X1304	Si. Transistor	2SC1685(R)
X1305	Si. Transistor	2SC1685(R)
X1401	Si. Transistor	2SD478
X1402	Si. Transistor	2SD478
X1501	Si. Transistor	2SC2610BK
X1701	Si. Transistor	2SC1685(P-S)
D1101	Si. Diode	W06A
D1102	Si. Diode	W06A
D1103	Si. Diode	W06A
D1301	Si. Diode	1S2473H
D1401	Si. Diode	1S2473H
D1402	Zener Diode	RD10F(C)
D1503	Si. Diode	HF-1
D1504	Si. Diode	V09E
D1505	Zener Diode	RD11E(B)
D1506	Si. Diode	W06A
D1507	Si. Diode	1SS81
D1508	Si. Diode	1S2473H
△D1701	△Zener Diode	RD20EV2
△D1901	△Si. Diode	1S1887A
△D1902	△Si. Diode	1S1887A
△D1903	△Si. Diode	1S1887A
△D1904	△Si. Diode	1S1887A
<b>Miscellaneous</b>		
<b>Symbol</b>	<b>Description</b>	<b>Part Number</b>
△F1901	△Fuse 1A	QMF53U1-1R0S
△F1902	△UL Fuse 3A	QMF66U1-3R0S

## CRT Socket P.C.B. Ass'y (SU-3016A) Parts List

### Resistors

Symbol	Description	Part Number
R3105	V R 200 $\Omega$	QVZ3234-022
R3106	V R 200 $\Omega$	QVZ3234-022
R3113	V R 5K $\Omega$	QVZ3234-053
R3114	V R 5K $\Omega$	QVZ3234-053
R3115	V R 5K $\Omega$	QVZ3234-053
R3116	OM R 10K $\Omega$ 2W J	QRG029J-103
R3117	OM R 10K $\Omega$ 2W J	QRG029J-103
R3118	OM R 10K $\Omega$ 2W J	QRG029J-103
R3119	Comp. R 3.3K $\Omega$ ½W K	QRZ0039-332
R3120	Comp. R 3.3K $\Omega$ ½W K	QRZ0039-332
R3121	Comp. R 3.3K $\Omega$ ½W K	QRZ0039-332

### Capacitors

Symbol	Description	Part Number
C3107	E Cap. 10 $\mu$ F 250V A	QEW52EA-106
C3108	C Cap. 1000pF DC1400V P	QCZ9001-102M

### Coils

Symbol	Description	Part Number
L3101	Peaking coil	QQL043K-101

### Semiconductors

Symbol	Description	Part Number
X3101	Si. Transistor	2SC2611
X3102	Si. Transistor	2SC2611
X3103	Si. Transistor	2SC2611

### Miscellaneous

Symbol	Description	Part Number
△	△ CRT Socket	A75522



## **VII Schematics and Wiring Diagrams**

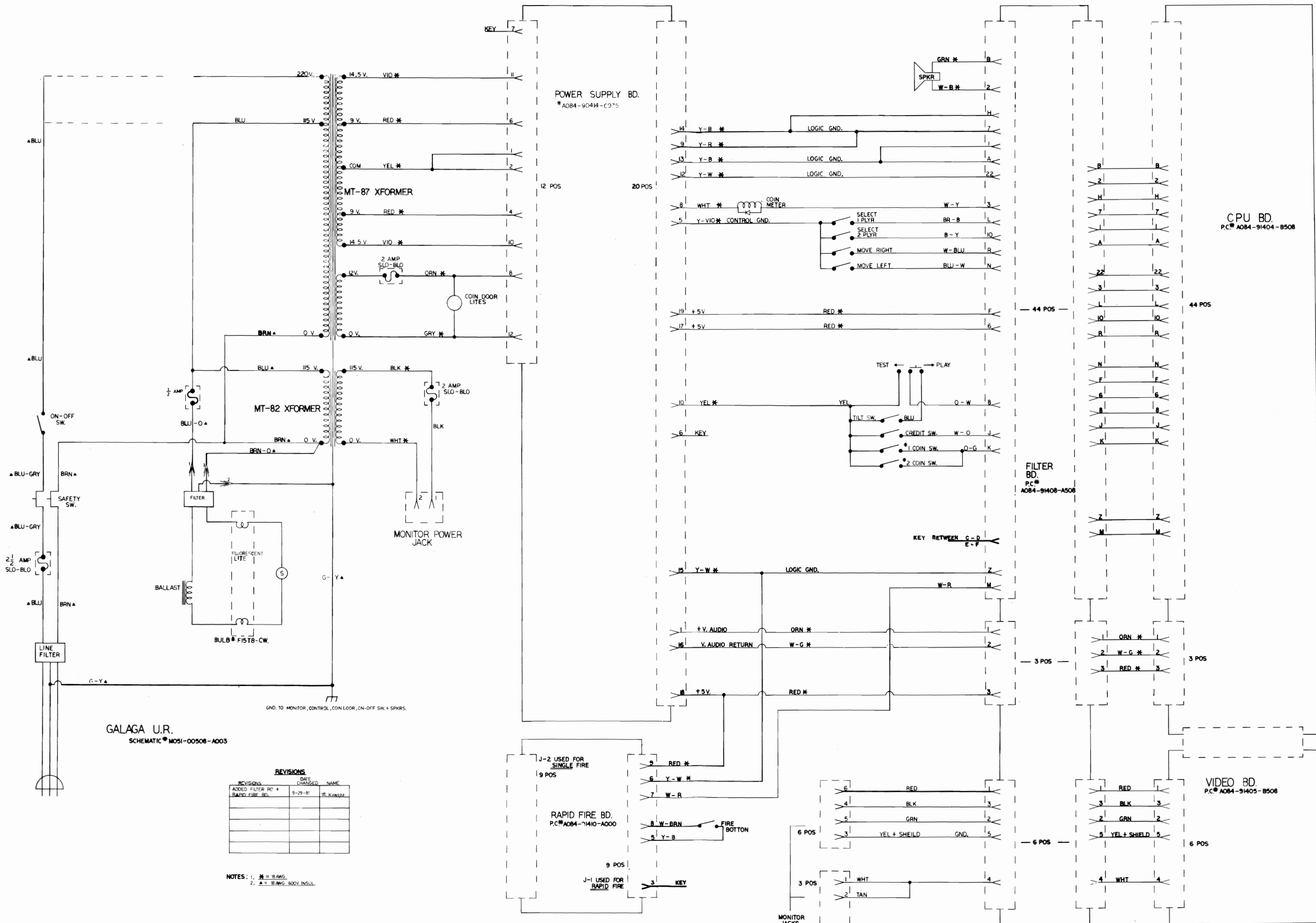

GALAGA U.R.  
SCHEMATIC # M051-00508-A003

**REVISIONS**

REVISIONS	DATE	CHANGED BY	NAME
ADDED FILTER RD + RAPID FIRE BD.	9-29-81	W. King	

NOTES: 1. \* = 18 AWG  
2. ▲ = 18 AWG, 600V. INSUL.

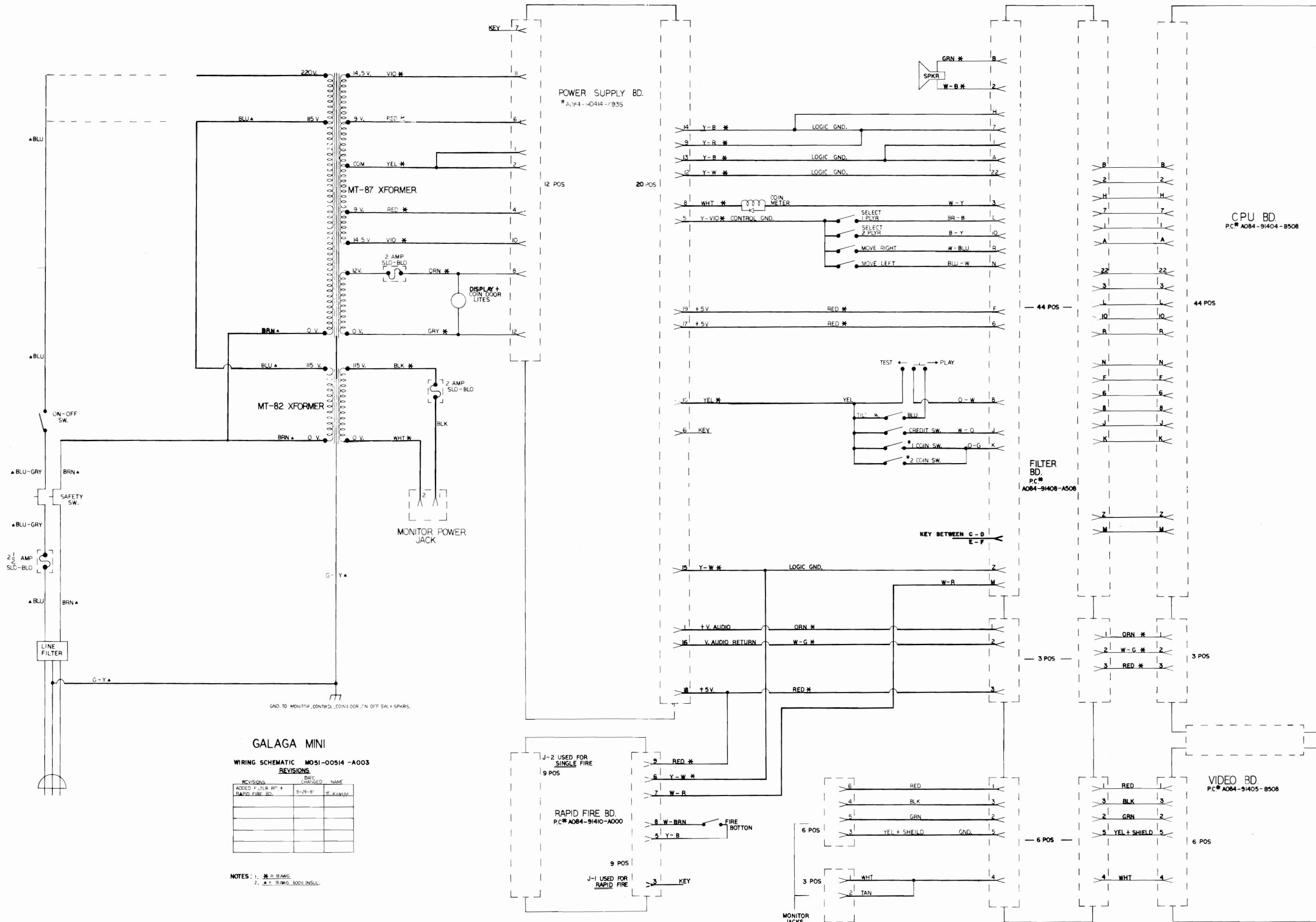

**GALAGA MINI**  
 WIRING SCHEMATIC M051-00514 -A003  
 REVISIONS

REV. NO.	DATE	BY	NAME
1	9-29-81	W. K. Knepp	ADDED FILTER RP + RAPID FIRE BD.

NOTES: 1. \* = 18AWG  
 2. ▲ = 18AWG 500V INSUL.

POWER SUPPLY BD.  
 # A104-40414-1935

12 POS

20 POS

12 POS

20 POS

9 POS

RAPID FIRE BD.  
 P.C.# A084-91410-A000

9 POS

J-1 USED FOR RAPID FIRE

J-2 USED FOR SINGLE FIRE

9 POS

CPU BD.  
 P.C.# A084-91404-8508

44 POS

FILTER BD.  
 P.C.# A084-91408-A508

3 POS

VIDEO BD.  
 P.C.# A084-91405-8508

6 POS

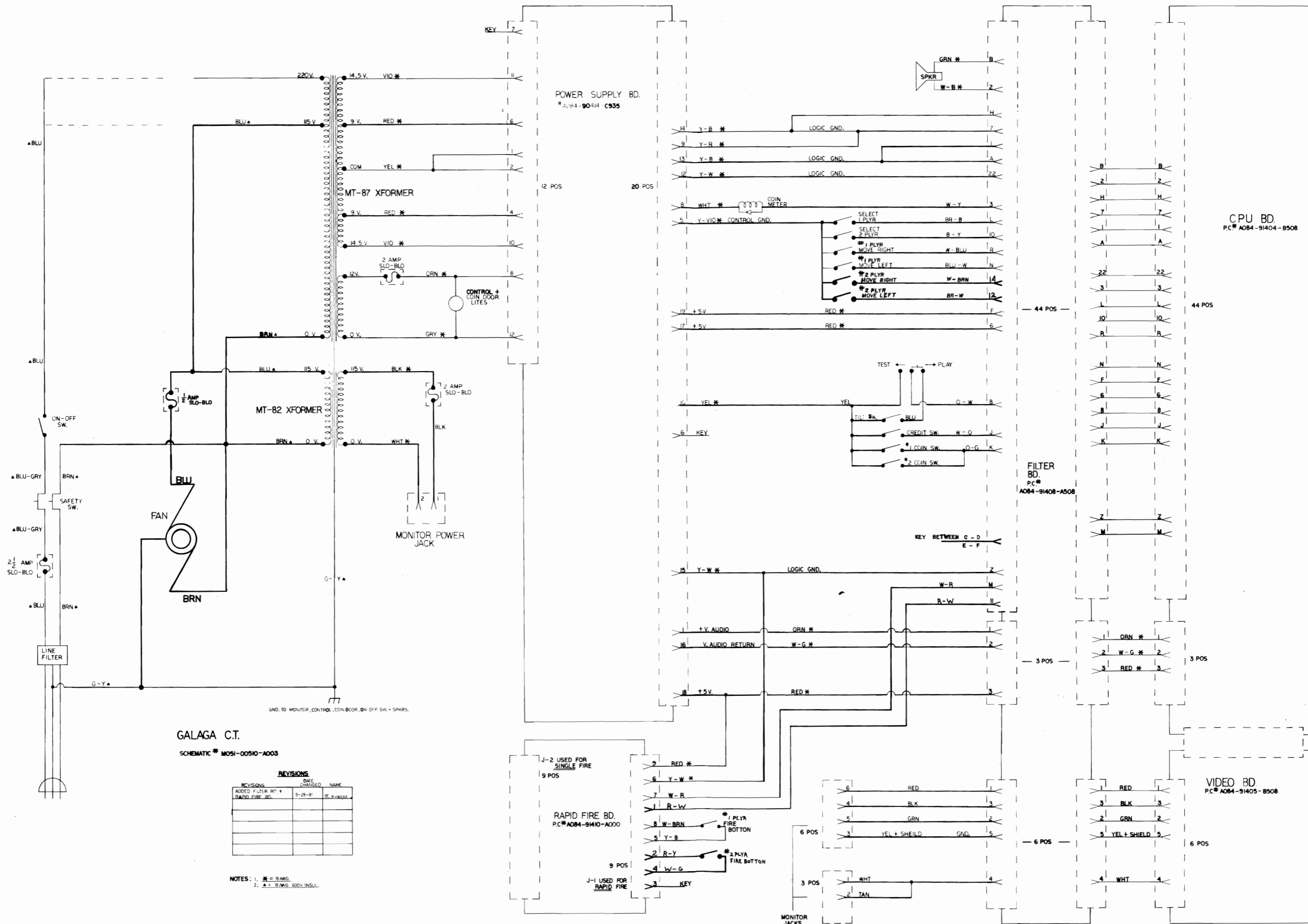

**GALAGA C.T.**  
SCHEMATIC # MOSI-00510-A003

**REVISIONS**

NO.	REVISIONS	DATE	NAME
1	ADDED FILTER RD + RAPID FIRE BD.	9-29-81	W. K. KANG

NOTES: 1. \* = 5/8" DIA.  
2. \* = 1/8" DIA. HOV. INSUL.

DESIGNATION	DESCRIPTION
C1	10000 MF 35V AX. ELEC.
C2	.01MF 50V AX. CER.
C3	1MF 25V TANT.
C4	20000MF 16V AX. ELEC.
C5	100PF 50V AX. CER
C6	470 MF 16V AX. ELEC.
C7	4700 MF 25V " "
R1	470 OHM 1/4W 5% CRBN
R2	100 " " " "
R3	2.7K " " " "
R4	560 " " " "
R5	510 " " " "
R6	10 " " " "
VR1	100 OHM 1/4W CRBN. FLM.
D1, D2	A14F
D3	IN4004
D4, D5	MR750
D6-D9	A15F
D10	A14F
Q1	TIP31
Q2	2N3055
U1	LM317
U2	3532
L1	FERROXCUBE BEAD
HS1	HEAT SINK
F1	FUSE 2A
F2	" 8A
F3	" 6A
FC1A, FC1B, FC2A, FC2B, FC3A, FC3B	FUSECLIP W/ STOP
J1	CONN. KK.156 (RA)(5-PIN) (6-PIN)
J2	" " (RA)(5-PIN) (13-PIN)
MHQ1	MOUNTING HARDWARE Q1 (1) SCREW 4-40X10 SLT RND (1) WSH 4 120-.250-018 (1) HEXNUT 4-40 (1) SHOULDER WSH. 974-302 THERMAL COMPOUND AS REQ. (1) TO-220 INSULATOR RT-3.5 MICA
MHQ2	MOUNTING HARDWARE Q2 (2) SCREW 4-40 X10 SLT RND (2) WSH 4 120-.250-018 (2) HEXNUT 4-40 (2) SHOULDER WSH. 974-302 THERMAL COMPOUND AS REQ. (1) TO-3 RT-1.5 FILM
MHUI	MOUNTING HARDWARE U1 (1) SCREW 4-40X10 SLT RND (1) WSH 4 120-.250-018 (1) HEXNUT 4-40 (1) SHOULDER WSH. 974-302 THERMAL COMPOUND AS REQ. (1) TO-220 INSULATOR RT-3.5 MICA
TW1-TW3	TIE WRAPS

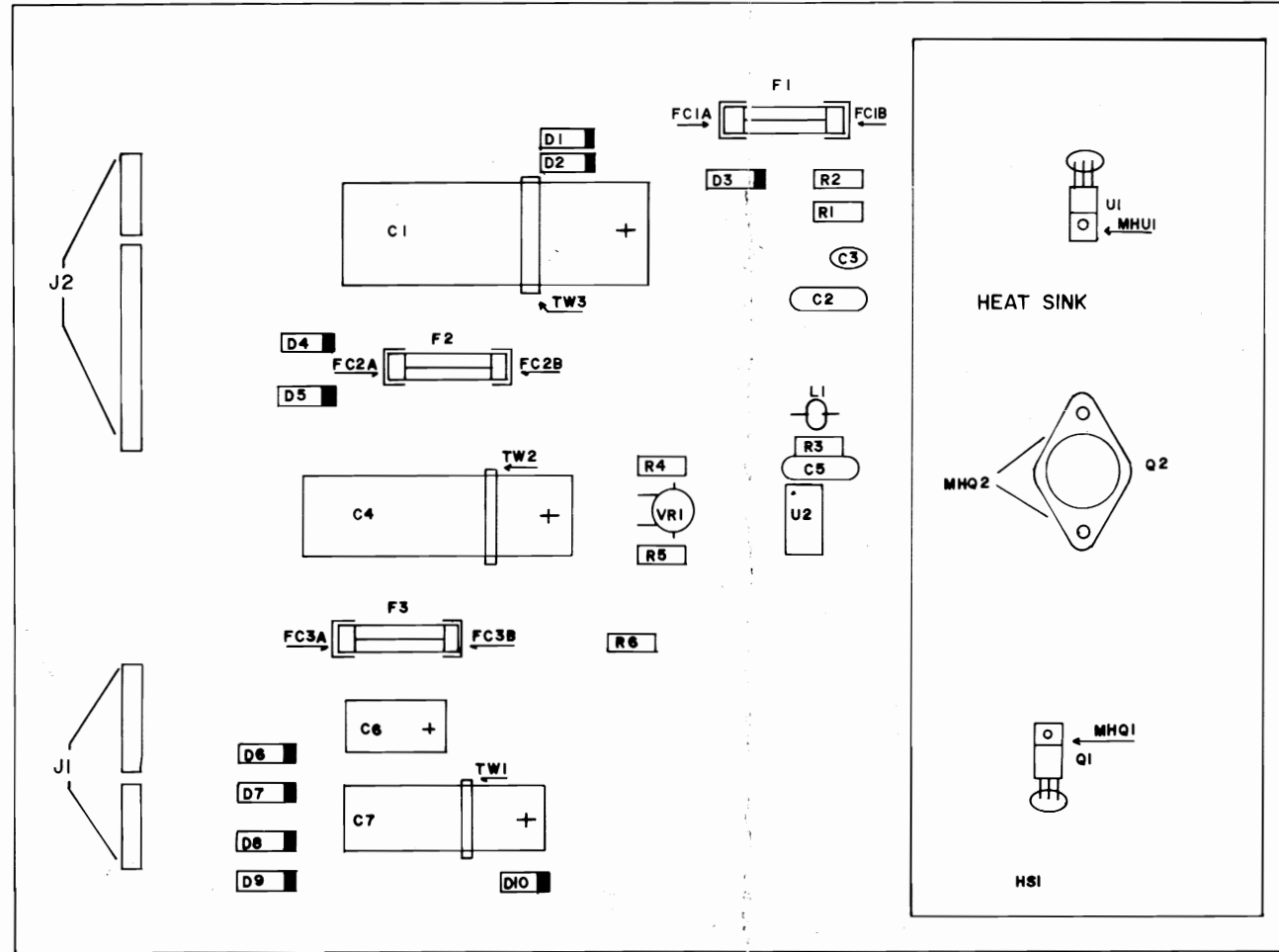

DESCRIPTION	QTY	DESIGNATION	PART NUMBER
100 PF 50v AX. CER.	1	C5	0171-043H6-JXXV
.01MF " " "	1	C2	0171-097H2-JXXX
1MF 25v TANT.	1	C3	0935-00814-0100
470MF " AX. ELEC.	1	C6	0175-271EX-EXXX
4700MF " " "	1	C7	0175-314EX-EXBX
10000MF 35v AX. ELEC.	1	C1	0175-322GX-EXBX
20000 16v MF " "	1	C4	0935-00814-0800
10 OHM 1/4w 5% CBN	1	R6	0062-051B3-1XXX
100 " " " "	1	R2	0062-110B3-1XXX
470 " " " "	1	R1	0062-156B3-1XXX
510 " " " "	1	R5	0062-159B3-1XXX
560 " " " "	1	R4	0062-162B3-1XXX
2.7K " " " "	1	R3	0062-199B3-1XXX
100 " " CBN FLM	1	VR1	0063-025AX-1DEX
1N4004	1	D3	0508-00801-0200
A14F	3	D1, D2, D10	0064-168XX-XXGX
A15F	4	D6-D9	0064-169XX-XXGX
MR750	2	D4, D5	0064-303XX-XXJX
TIP31	1	Q1	0065-485XX-XXXX
2N3055	1	Q2	0935-00800-0000
3532	1	U2	0066-044BX-XXXX
LM317	1	U1	0935-00804-3600
FERROXCUBE BEAD	1	L1	0017-00009-0225
HEAT SINK	1	HS1	0068-045XX-ABDX
FUSE 2A	1	F1	0017-00003-0005
FUSE 6A	1	F3	0017-00003-0008
FUSE 8A	1	F2	0017-00003-0184
FUSECLIP	6	FC1A, FC1B, FC2A, FC2B, FC3A, FC3B	0017-00003-0214
KK 156 (RA) (5)	2	J1, J2	3000-16387-0500
KK 156 (RA) (6)	1	J1	3000-16387-0600
KK 156 (RA) (13)	1	J2	3000-16387-1300
SCREW 4-40x10	4	MHU1, MHQ1, MHQ2	0017-00101-0727
WSH 4 120-.250-018	4	" " "	0017-00104-0071
HEXNUT 4-40	4	" " "	0017-00103-0002
SHOULDER WSH	4	" " "	0017-00042-0109
THERMAL COMPOUND	AS REQ.	" " "	0017-00009-0204
TO-220 INSULATOR	2	MHU1, MHQ1	0017-00003-0205
TO-3 INSULATOR	1	MHQ2	0017-00042-0108
TIE WRAPS	3	TW1-TW3	0017-00042-0105

MOSI-00935-C028

THIS DWG IS CONFIDENTIAL & PROPERTY OF MIDWAY MFG CO

DIM TOLERANCES UNLESS OTHERWISE SPEC	FIRST USED ON DATE	GALAGA	SCALE	10-10-B1 FULL
CONCENTRICITY TIR FRACTIONAL	002			
DECIMAL	± .154			
HOLE DIA	+ .002 - .000			
ANGLE	± 1/2°			
DO NOT SCALE DWG				
<b>MIDWAY MFG. CO.</b> FRANKLIN PK., IL 60131 A BALLY CO.				
<b>POWER SUPPLY</b>				
REVISIONS				
PART NO A.084-9.0.4.1.4-C.9.3.5				

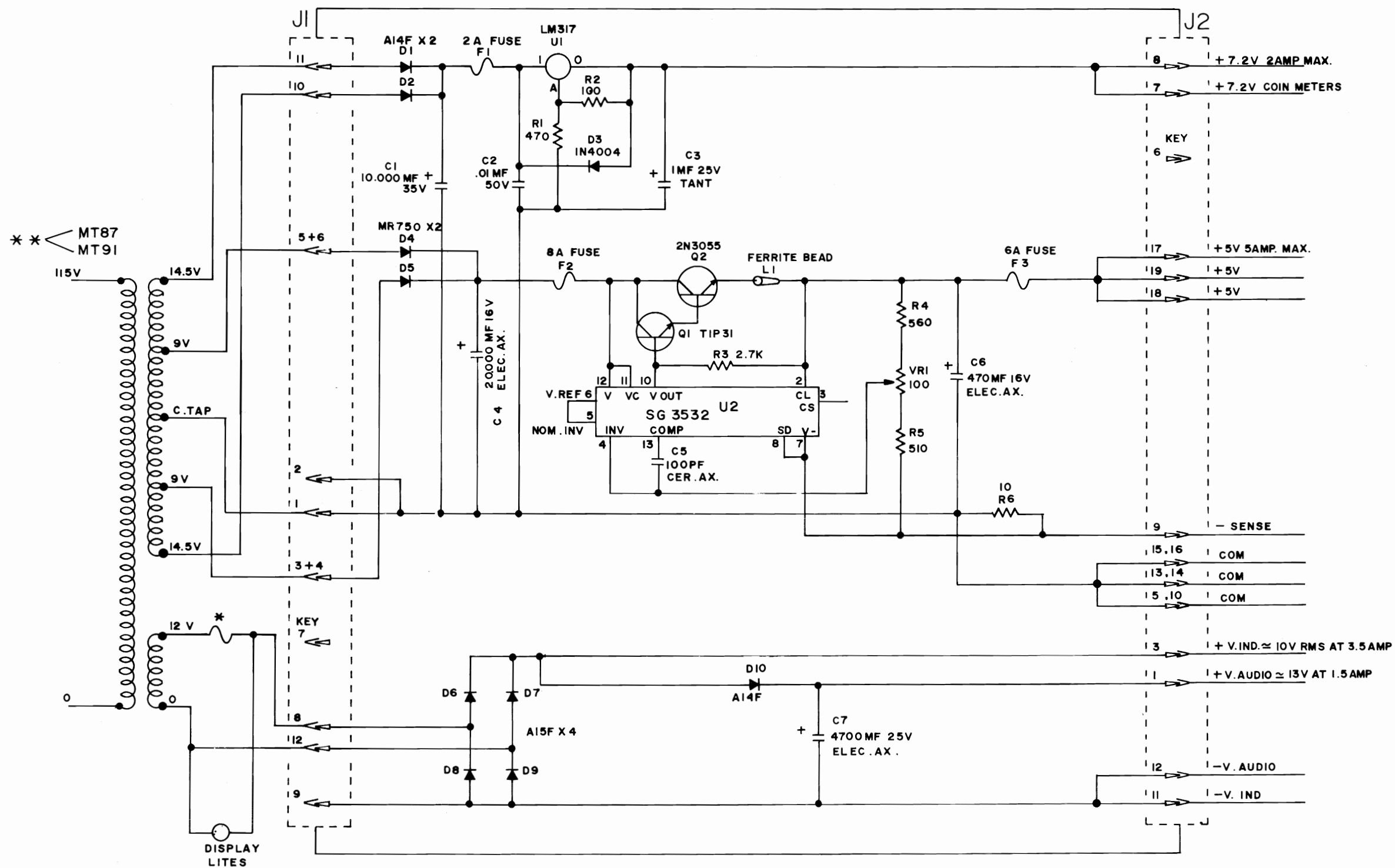

NOTES:

\* 2AMP FUSE W/O DISPLAY LITES

\*\* MT87 FOR UR.

MT91 FOR C.T.

SCHEMATIC: M051-00935-C025

REVISIONS

USED ON GALAGA

MIDWAY MFG. CO.

FRANKLIN PK ILL

DO NOT SCALE DWG.	HEAT TREAT	SCALE	FULL	NO REQ'D   PER
DIM. TOLERANCES UNLESS SPECIFIED	DRN <i>m.m.</i>	MAT'L		
CONCENTRICITY T1 R. 003	CKD.	FINISH		
FRACTIONAL .125	DATE 10-1-81			
DECIMAL .005				
SOLE DIA. +.002 .000				

POWER SUPPLY

PART NO.

A084-90414-C935

DESIGNATION LIST

DESIGNATION	DESCRIPTION	DESIGNATION	DESCRIPTION
C1	470 MF 16V AX ELEC.	IC 5C,5D,5E,5F,5H,5J	74LS161
C2	.001MF 50V CER	" 5K	74LS259
C3	220 PF 500V 5% MICA.	" 5L	74LS20
C4-C21	.1MF 50V CER.	" 5M	74LS257
		" 5N	GG-5 PROM (32X8)
		" 6A	74LS365
		" 6B	"VIDEO RAMKIT" - "OPTION 1"
R1	220 OHM 1/4W 5% CRBN.	" 6C,6D,6E,6F	"VIDEO RAMKIT" - "OPTION 2"
R2	470 " " " " "	" 6H	"VIDEO RAMKIT" - "OPTION 1"
R3	220 " " " " "	" 6J,6K,6L,6M	"VIDEO RAMKIT" - "OPTION 2"
R4	470 " " " " "	" 6N	74LS86
R5	1K " " " " "		
R6	220 " " " " "	ICS IC	16-PIN IC SOCKET
R7	470 " " " " "	" 1H	28-PIN " "
RB,R9	1K " " " " "	" 1K	24-PIN " "
R10	100 " " " " "	" 1L,1N	28-PIN " "
RI-R14	470 " " " " "	" 2N	16-PIN " "
R15,R16	1K " " " " "	" 3E,3F,3H,3J,3K,3L	18-PIN " "
R17	330 " " " " "	" 4D,4F	24-PIN " "
RI8-R22	1K " " " " "	" 4H	28-PIN " "
		" 4L,4M	24-PIN " "
		" 5N	16-PIN " "
RM1-RM4	2.2K OHM 8-UNIT 9-PIN SIP	J1	CONN- R.A. HEADER 50-PIN
RM5	1K " " " " "	J2	CONN- PCB HEADER 6-PIN
RM6-RM8	1K OHM 4-UNIT 5-PIN SIP	MHI-MH4	DUAL LKG PCB SPACER
		PCB	A080-91405-B508
IC 1B	74LS153	<b>CABLE ASSY</b> AS BELOW	
" IC	GG-3 PROM (256X4)	PI, P2	PLUG - SOCKET CONNECTOR 50-PIN
" ID	74LS08	CABLE	RIBBON CABLE - .33FT 50-CONNECTOR
" IE	74LS138		28 GA. STRND.RND. CONDUCTOR
" IF	74LS32		
" IH	04XX CUSTOM IC		
" IK	STATIC RAM (2KX8)		
" IL	00XX CUSTOM IC		
" IN	07XX " "		
" 2B	74LS20		
" 2C	74LS273		
" 2D	74LS377		
" 2E	74LS273		
" 2F,2H,2J,2K	74LS245		
" 2L	74LS273		
" 2M	74LS377		
" 2N	GG-4 PROM(256X4)		
" 3A	74LS20		
" 3B	74LS86		
" 3C,3D	74LS283		
" 3E,3F,3H,3J,3K,3L	2114-2 RAM(1KX4)		
" 3M	74LS00		
" 3N	74LS368		
" 4A	74LS157		
" 4B,4C	74LS86		
" 4D	GG-L EPROM (4096X8)		
" 4F	GG-K " "		
" 4H	02XX CUSTOM IC		
" 4L	GG-J EPROM(4096X8)		
" 4M	05XX CUSTOM IC		
" 5A	74LS365		
" 5B	74LS298		

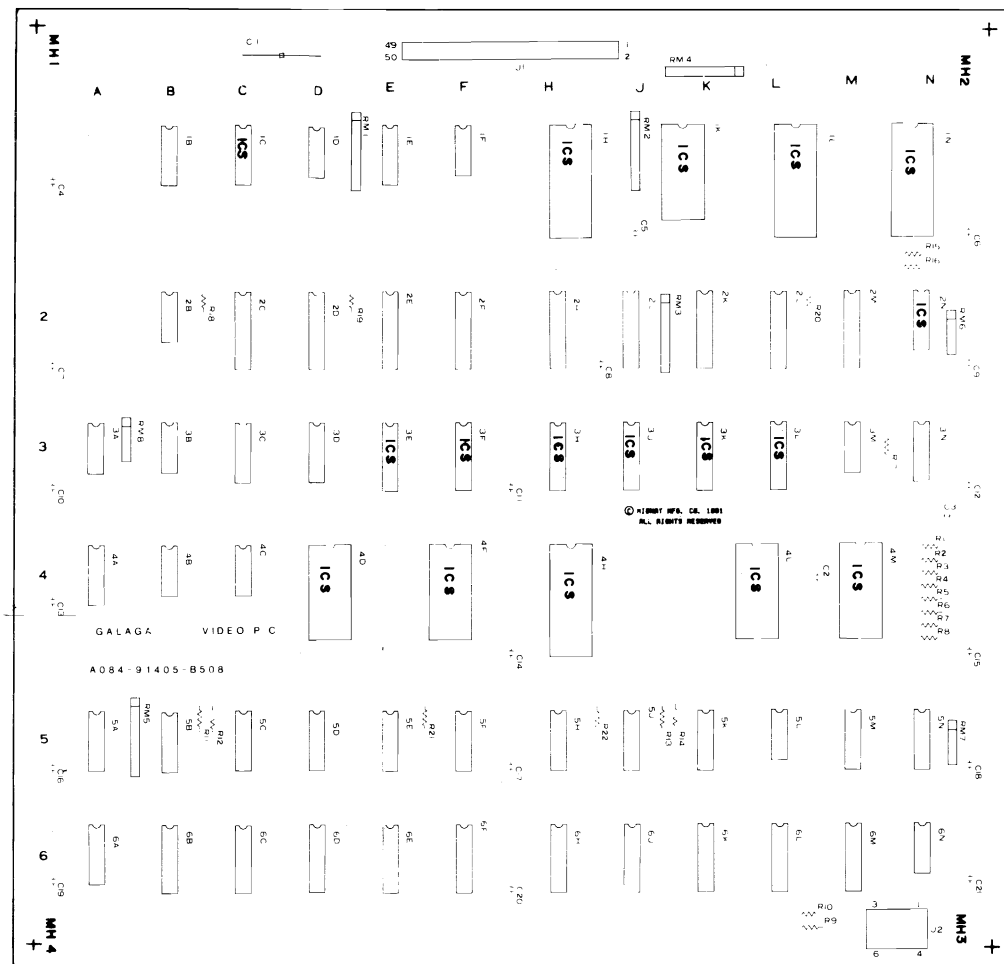
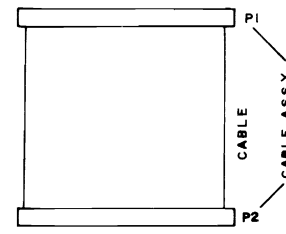

CROSS REFERENCE LIST

DESCRIPTION	QUANTITY	DESIGNATION	PART #
220PF 500V 5% MICA CAP	1	C3	0508-00600-0100
.001MF 50V CER CAP	1	C2	0508-00800-0200
.1MF " " " " "	18	C4-C21	0508-00800-0300
470MF 16V AX. ELEC	1	C1	0508-00800-0400
100 OHM 1/4W 5% CRBN. RES.	1	R10	0062-11083-1XXXX
220 " " " " "	3	R1, R3, R6	0062-13383-1XXXX
330 " " " " "	1	R17	0062-14483-1XXXX
470 " " " " "	7	R2, R4, R7, R11- R14	0062-15683-1XXXX
1K " " " " "	10	R5, R8, R9, R15, R16, R18-R22	0062-17883-1XXXX
1K SIP (4-UNIT) 5-PIN	3	RM6-RM8	0508-00804-0100
1K SIP (8-UNIT) 9-PIN	1	RM5	0508-00804-0200
2.2K " " " " "	4	RM1-RM4	0508-00804-0300
00XX CUSTOM IC	1	IC1L	0066-001CX-XAPX
02XX " " " " "	1	IC4H	0066-002CX-XAPX
04XX " " " " "	1	IC1H	0066-003CX-XAPX
05XX " " " " "	1	IC4M	0066-004CX-XAPX
07XX " " " " "	1	IC1N	0066-006CX-XAPX
2114-2 ST. RAM 200NS.(1024X4)	6	IC 3E,3F,3H,3J,3K,3L	0508-00803-0300
74LS00	1	IC3M	0508-00803-0400
74LS08	1	IC1D	0508-00803-0500
74LS20	3	IC2B, 3A, 5L	0508-00803-0600
74LS32	1	IC1F	0508-00803-0700
74LS86	4	IC3B, 4B, 4C, 6N	0508-00803-0800
74LS138	1	IC1E	0508-00803-0900
74LS153	1	IC1B	0508-00803-1000
74LS157	1	IC4A	0508-00803-1100
74LS161	6	IC5C, 5D, 5E, 5F, 5H, 5J	0508-00803-1200
74LS245	4	IC2F, 2H, 2J, 2K	0508-00803-1300
74LS257	1	IC5M	0508-00803-1400
74LS259	1	IC5K	0508-00803-1500
74LS273	3	IC2C, 2E, 2L	0508-00803-1600
74LS283	2	IC3C, 3D	0508-00803-1700
74LS298	1	IC5B	0508-00803-1800
74LS365	2	IC5A, 6A	0508-00803-1900
74LS368	1	IC3N	0508-00803-2000
74LS377	2	IC2D, 2M	0508-00803-2100
GG-3 PROM (256X4)	1	IC1C	0508-00803-2900
GG-4 " " " " "	1	IC2N	0508-00803-3000
GG-5 PROM (32X8)	1	IC5N	0508-00803-3100
GG-J EPROM(4096X8)	1	IC4L	0508-00803-2600
GG-K " " " " "	1	IC4F	0508-00803-2700
GG-L " " " " "	1	IC4D	0508-00803-2800
STATC RAM (2KX8)	1	IC1K	0508-00803-2500
* "VIDEO RAM KIT"	1	MAIN PHATOM	0508-00803-4000
* OPTION 1	1	SUB PHATOM	NOT RELEASED
- 2148 RAM (1KX4)	2	IC 6B, 6H	(IN ABOVE NUMBER)
* OPTION 2	1	SUB PHATOM	0508-00803-2200
- 2147 RAM (4KX1)	8	IC 6C, 6D, 6E, 6F, IC 6J, 6K, 6L, 6M	(IN ABOVE NUMBER)
* NOTE: ASSEMBLY TO INCLUDE EITHER "OPTION 1" OR "OPTION 2" AS PER LATEST RELEASED B.O.M.			
16-PIN IC SOCKET	3	IC5IC, 2N, 5N	0508-00804-0700
18-PIN " " " " "	6	IC5 3E, 3F, 3H, 3J, 3K, 3L	0508-00804-0800
24-PIN " " " " "	5	IC5 1K, 4D, 4F, 4L, 4M	0508-00804-0900
28-PIN " " " " "	4	IC5 1H, 1L, 1N, 4H	0508-00804-0400
CONNECTOR - R.A. HEADER 50-PIN	1	J1	0508-00804-0800
CONNECTOR - PCB HEADER 6-PIN	1	J2	0017-00021-0424
MOUNTING HARDWARE - DUAL LKG PCB SPACER	4	MHI-MH4	0017-00042-0253
PCB	1	"GALAGA" VIDEO P.C.B	A080-91405-B508
<b>CABLE ASSEMBLY</b>	1	<b>CABLE ASSY</b>	A508-00027-0000
50-PIN			
PLUG - SOCKET CONNECTOR	2	PI, P2	0508-00804-0900
RIBBON CABLE - .33FT	1	CABLE	0017-00033-0346
50-CONDUCTOR 28GA. STRND AND CONDUCTOR			

PROJECT ENG: JERRY SZERSZEN ASSEMBLY MOSI-00508-8007

DO NOT SCALE DWG	HEAT TREAT	SCALE	USED ON GALAGA	REVISIONS
DIM TOLERANCES UNLESS SPECIFIED	MAT L	FULL	NO REQD IPER	
CONCENTRICITY ±.001	FINISH			
DATE: 09-22-81				

GALAGA VIDEO P.C. A084-91405-B508

MIDWAY MFG. CO. FRANKLIN PK ILL

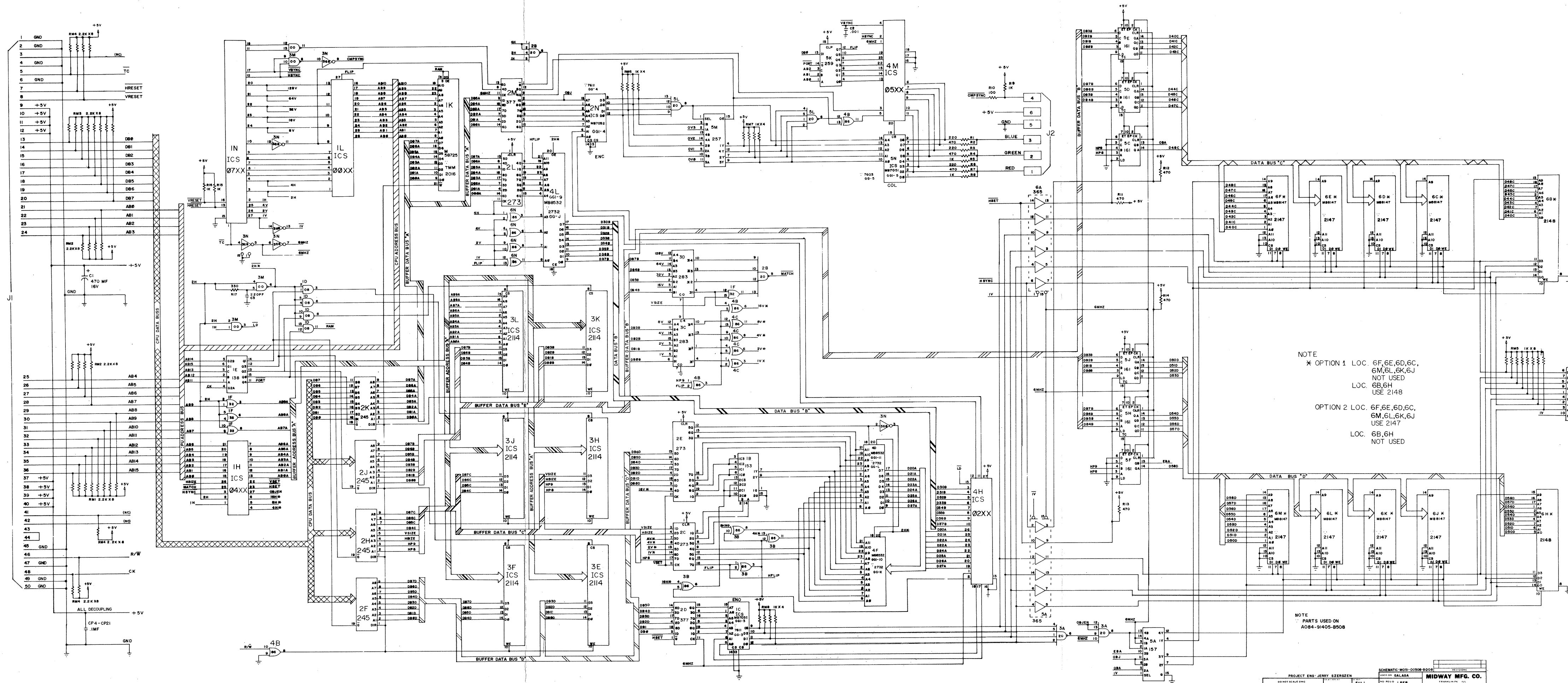

NOTE  
 \* OPTION 1 LOC. 6F,6E,6D,6C,  
 6M,6L,6K,6J  
 NOT USED  
 LOC. 6B,6H  
 USE 2148

OPTION 2 LOC. 6F,6E,6D,6C,  
 6M,6L,6K,6J  
 USE 2147  
 LOC. 6B,6H  
 NOT USED

NOTE  
 PARTS USED ON  
 A084-91405-B508

PROJECT ENG. JERRY SIENZSEN	SCHEMATIC MODS. 00508-B508
DESIGNED BY GALAGA	MIDWAY MFG. CO.
FULL	PER
GALAGA VIDEO P.C.	A084-91405-B508



DESIGNATION LIST

DESIGNATION	DESCRIPTION
C1	470MF 16V AX. ELEC
C2-C17	.01MF 50V CER
C18	.1MF " "
C19	.01MF " "
C20	22 MF 35V AX. ELEC
C21	220 MF 16V AX. ELEC
C22	100 MF
C23,C24	.15 MF 25V 10% RD.TANT
C25	10MF 16V AX. ELEC
C26-C29	.01MF 100V 10% MYLAR
C30-C42	NOT USED
C43	.0022 MF 50V 10% CER
C44	10MF 16V AX. ELEC
C45	100PF 50V CER
C46-C63	.1MF 50V CER
R1, R2	330 OHM 1/4w 5% CRBN
R3,R4	NOT USED
R5	100 OHM 1/4 5% CRBN
R6	1K " " " "
R7,R8	10K " " " "
R9	NOT USED
R10	10K OHM 1/4w 5% CRBN
R11	47K " " " "
R12	47K " " " "
R13	100K " " " "
R14	NOT USED
R15	470 OHM 1/4w 5% CRBN
R16	1K " " " "
R17	2.2K " " " "
R18	4.7K " " " "
R19	10K " " " "
R20	3.3K " " " "
R21-R28	NOT USED
R29	4.7K OHM 1/4w 5% CRBN
R30	10K " " " "
R31	22K " " " "
R32,R33	47K " " " "
R34	10K " " " "
R35	150K " " " "
R36	33K " " " "
R37	10K " " " "
R38	3.3K " " " "
R39	2.2K " " " "
R40	470K " " " "
R41	22K " " " "
R42	150K " " " "
R43	4.7K " " " "
R44	10K " " " "
R45	22K " " " "
R46	47K " " " "
R47,R48	NOT USED
R49,R50	10K OHM 1/4w 5% CRBN
R51	1K " " " "
R52-R54	NOT USED
R55	1K OHM 1/4w 5% CRBN
R56-R63	4.7K " " " "
R64,R65	33PF 50V CER
CX1	100PF " "
CX2	1K OHM 1/4w 5% CRBN
RX1	1K OHM 1/4w 5% CRBN

DESIGNATION	DESCRIPTION
RM1-RM3	1K OHM 4-UNIT 5-PIN SIP
RM4	1K OHM 8-UNIT 9-PIN SIP
RM5	1K OHM 4-UNIT 5-PIN SIP
RM6, RM7	1K OHM 8-UNIT 9-PIN SIP
RM8	NOT USED
RM9	1K OHM 4-UNIT 5-PIN SIP
RM10-RM13	2.2K OHM 4-UNIT 8-PIN SIP
RM14, RM15	NOT USED
RM16	220 OHM 4-UNIT 8-PIN SIP
RM17-RM20	2.2K OHM 8-UNIT 9-PIN SIP
RM21, RM22	4.7K OHM 8-UNIT 9-PIN SIP
VR1	1K OHM 1/4w CRBN POT UP W/O KNOB ALPS HIOSIA-IKOHM
D1	IN914B
D2-D4	NOT USED
Q1	2N3391A
Q2	2N4403
Q3, Q4	NOT USED
Q5	TIP 110
Q6-Q8	NOT USED
IC1A	74LS107
" IC	74LS285
" IC	74LS174
" ID	GG-1 PROM (256X4)
" IE,IF,IH,IJ,IK,IL	74LS367
" IM,IN	74LS367
" IP	74LS138
" 2A,2B	7489
" 2C	74LS157
" 2D	74LS158
" 2E,2H,2J	08XX CUSTOM IC
" 2L	06XX " "
" 2M,2N	NOT USED
" 2P	74LS138
" 3A	4066 CMOS
" 3B	74LS273
" 3C	74LS259
" 3D	NOT USED
" 3E	GG-6 EPROM (4KX8)
" 3H	NOT USED
" 3J	GG-E EPROM (4KX8)
" 3K	GG-D " "
" 3L	GG-C " "
" 3M	GG-B " "
" 3N	GG-A " "
" 3P	74LS32
" 4B	74LS139
" 4C	74LS32
" 4D	07XX CUSTOM IC
" 4E	Z80 MICROPROCESSOR 2.5MHZ
" 4H	51XX CUSTOM IC
" 4J	Z80 MICROPROCESSOR 2.5MHZ
" 4K	74LS151
" 4L	NOT USED
" 4M	Z80A MICROPROCESSOR 4.0 MHZ

DESIGNATION	DESCRIPTION
IC4P	74LS139
" 5A	74LS368
" 5B	74LS107
" 5C	GG-2 PROM (256X4)
" 5K	74LS151
" 5P	LM324
" 6A	74LS393
" 6B	74128
" 6C	74LS139
" 6H	NOT USED
" 6L	" "
" 6M	54XX CUSTOM IC
" 7C	MB3730
ICS ID	16-PIN IC SOCKET
" 2E,2H,2J,2L	28-PIN " "
" 3E,3J,3K,3L,3M,3N	24-PIN " "
" 5A	16-PIN " "
" 5B	14-PIN " "
" 5C	16-PIN " "
" 4D	28-PIN " "
" 4E	40-PIN " "
" 4H	42-PIN " "
" 4J, 4M	40-PIN " "
" 6M	28-PIN " "
XTAL1	18.432 MHZ CRYSTAL
SW1	AKC-8 P.B SWITCH
DIP SW 6J,6K	8-POS DIP SWITCH
J1	CONN.- R.A. HEADER 50-PIN
J2	CONN.- PCB HEADER 3-PIN
MHIC7C	MOUNTING HARDWARE
"	(-2) 4-40 HEX NUT
"	(-2) 4-40 X 8 SLT. PAN M.S
"	(-2) WSH. 4 .125-250-.032 FLT. ST.
"	(-2) WSH. 4 .120-250-.018 EXT. ST.
A080-91404-C508	GALAGA CPU P.C.B

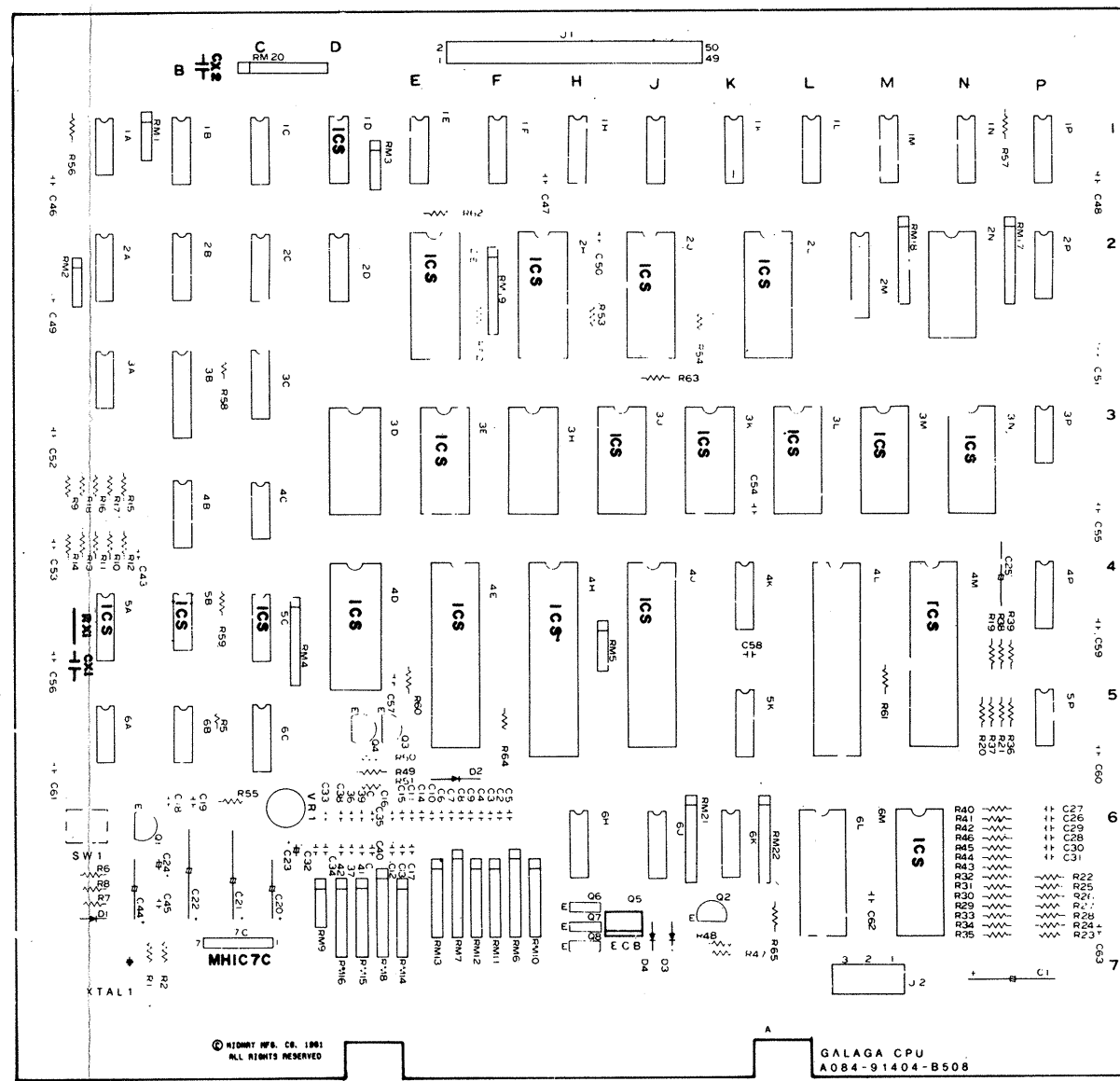

CROSS REFERENCE LIST

DESCRIPTION	QUANTITY	DESIGNATION	PART #	DESCRIPTION	QUANTITY	DESIGNATION	PART #
33PF 50V CER	1	CX1#	0508-00800-2000	74LS273	1	IC5B	0508-00803-1800
100PF " "	2	C46,CX2#*	0508-00800-0500	74LS283	1	IC1B	0508-00803-1700
.0022MF " "	1	C45	0508-00800-0500	74LS367	8	IC1E,IF,IH,IJ,IK,IL	0508-00803-4800
.01MF 25V CER	17	C2-C17,C19	0508-00800-0800			IM,IN	
.01MF 100V MYLAR	4	C26-C29	0508-00800-0700	74LS368	1	IC5A	0508-00803-2000
.1MF 50V CER	19	C18,C46-C63	0508-00800-0900	74LS393	1	IC6A	0508-00803-4900
.15MF 25V R.D TANT	2	C23,C24	0508-00800-1000	GG-1 PROM (256X4)	1	IC1D	0508-00803-3800
10MF 16V AX. ELEC	2	C25,C44	0508-00800-1100	GG-2 " "	1	IC5C	0508-00803-3900
22 MF 35V " "	1	C20	0508-00800-1200	GG-A EPROM 2732	1	IC3N	0508-00803-3200
100MF 16V " "	1	C22	0508-00800-1300	GG-C " "	1	IC3M	0508-00803-3500
220 MF 16V " "	1	C21	0508-00800-1400	GG-D " "	1	IC3L	0508-00803-3400
470MF 16V " "	1	CI	0508-00800-1500	GG-E " "	1	IC3K	0508-00803-3500
				GG-F " "	1	IC3J	0508-00803-3600
				GG-G " "	1	IC3E	0508-00803-3700
100 OHM 1/4w CRBN RESIS	1	R5	0062-110B3-1XXX	LM324	1	IC5P	0508-00803-5400
330 " " " "	2	R1,R2	0062-144B3-1XXX	MB3730	1	IC7C	0066-188XX-XX4X
470 " " " "	3	R15,R47,R48	0062-156B3-1XXX	Z-80 (2.5MHZ)	2	IC4E#J	0508-00803-5000
1K " " " "	14	R6,R16,R52-R54	0062-179B3-1XXX	Z-80A (4.0MHZ)	1	IC4M	0508-00803-5200
2.2K " " " "	2	R17,R59	0062-195B3-1XXX	14-PIN IC SOCKET	1	IC5B	0508-00804-1700
3.3K " " " "	2	R20,R38	0062-203B3-1XXX	16-PIN " "	3	IC5D,5A,5C	0508-00804-0700
4.7K " " " "	5	R18,R29,R43,R64,R65	0062-211B3-1XXX	24-PIN " "	6	IC5E,3J,3K,3L,3M,3N	0508-00804-0500
10K " " " "	9	R7,R8,R10,R19,R30	0062-227B3-1XXX	28-PIN " "	6	IC5E,2H,2L,2J,4D,6M	0508-00804-0400
				40-PIN " "	3	IC5A,4J,4M	0508-00804-1800
				42-PIN " "	1	IC5A4H	0508-00804-1900
22K " " " "	4	R11,R31,R41,R45	0062-243B3-1XXX				
33K " " " "	1	R36	0062-251B3-1XXX	18.432 MHZ CRYSTAL	1	XTAL1	0508-00804-1400
47K " " " "	4	R12,R32,R33,R46	0062-259B3-1XXX	P.B SWITCH AKC-8	1	SW1	0508-00804-1500
100K " " " "	1	R13	0062-275B3-1XXX	8-POS DIP SWITCH	2	6J,6K	0508-00804-1600
150K " " " "	2	R35,R42	0062-283B3-1XXX	CONN.-R.A. HEADER 50-PIN	1	J1	0508-00804-0800
470K " " " "	1	R40	0062-307B3-1XXX	CONN. PCB HEADER 3-PIN	1	J2	0017-00021-0443
220 OHM SIP (4-UNIT) 8-PIN	1	RM16	0508-00804-1100	MOUNTING HARDWARE ICTC		MHIC7C	
1K " " " 5-PIN	5	RM1-RM3, RM5, RM9	0508-00804-0100	4-40 HEX NUT	2	-	0017-00103-0002
1K " " " 9-PIN	3	RM4, RM6, RM7	0508-00804-0200	4-40 X 8 PAN M.S	2	-	0017-00101-0810
2.2K " " " 4-UNIT 8-PIN	4	RM10-RM13	0508-00804-1200	WASHER #4 FLT. ST.	2	-	0017-00104-0018
2.2K " " " 8-UNIT 9-PIN	4	RM17-RM20	0508-00804-0300	WASHER #4 EXT. ST.	2	-	0017-00104-0071
4.7K " " " "	2	RM21, RM22	0508-00804-1000				
1K OHM POTENTIOMETER	1	VR1	0508-00804-1300	GALAGA CPU PCB	1	A080-91404-C508	A080-91404-B508
IN914B	1	D1	0508-00801-0100				
2N3391A	1	Q1	0508-00802-0200				
2N4403	1	Q2	0508-00802-0100				
TIP 110	1	Q5	0508-00802-0300				
06XX CUSTOM IC	1	IC2L	0066-005CX-XAPX				
07XX " "	1	IC4D	0066-006CX-XAPX				
08XX " "	3	IC2E,2H,2J	0066-007CX-XAPX				
51X X " "	1	IC4H	0066-008CX-XAPX				
54XX " "	1	IC6M	0066-009CX-XAPX				
4066 CMOS	1	IC3A	0508-00803-5300				
74LS32	2	IC3P,4C	0508-00803-0700				
7489	2	IC2A,2B	0508-00803-4100				
74LS107	2	IC1A,5B	0508-00803-4200				
74128	1	IC6B	0508-00803-4300				
74LS138	2	IC1P,2P	0508-00803-0900				
74LS139	2	IC 3,6C	0508-00803-4400				
74LS139	1	IC 3	0508-00803-5100				
74LS151	2	IC4K,5K	0508-00803-4500				
74LS157	1	IC2C	0508-00803-1100				
74LS158	1	IC2D	0508-00803-4800				
74LS174	1	IC1C	0508-00803-4700				
74LS259	1	IC3C	0508-00803-1500				

ASSEMBLY M051-00508-C005

PROJECT ENG: JERRY SZERSZEN

DO NOT SCALE DWG

SCALE: FULL

HEAT TREAT: NONE

NO REQ'D IPER

USED ON GALAGA

MIDWAY MFG. CO.

FRANKLIN PK ILL.

GALAGA CPU P.C.

A084-91404-C508

DATE: 10-1-81

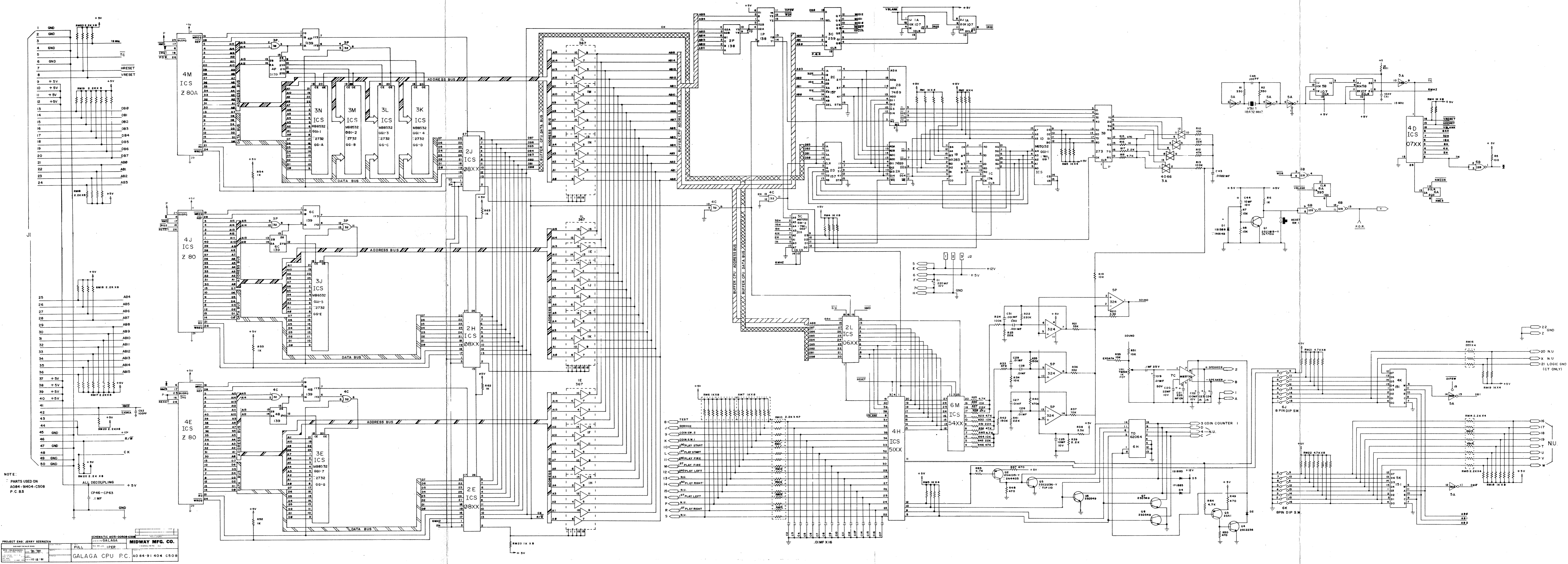

NOTE:  
PARTS USED ON  
A084-9404-C50B  
P.C.B.S.

PROJECT ENG. JERRY BERSEN	SCHMATIC MOD. 0008-0008	MIDWAY MFG. CO.
DESIGNED BY GALAGA	FULL	
DATE 10-77	BY J.P.E.R.	
GALAGA CPU P.C. A084-91404 C50B		

**DESIGNATION LIST**

DESIGNATION	DESCRIPTION
C1, C2	.1MF 100V MYLAR
C3-C7	.01MF 25V AX CER
R1-R4	1MEG OHM 1/4w 5% CRBN RES
R5	1K " " " " "
R6	68 " " " " "
R7	1K " " " " "
R8	68 " " " " "
U1	LM556
U2	7400
J1, J2	KK.156 VERT 2(6-PIN) 2(2-PIN)
MH1-MH4	SNAP BUSHING 1/4"

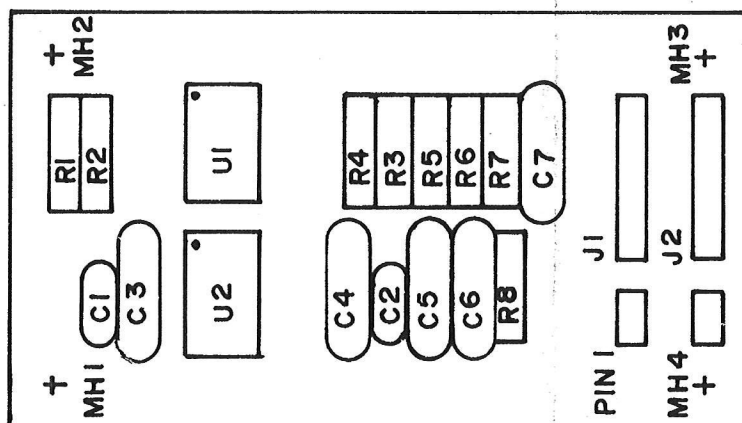

**CROSS REFERENCE LIST**

DESCRIPTION	QUANTITY	DESIGNATION	PART #
.01MF 25VAX CER	5	C3-C7	0508-00800-0800
.1MF 100V 10% MYLAR	2	C1, C2	0508-00800-2300
68 OHM 1/4w 5% CRBN RES.	2	R6, R8	0062-098B3-1XXX
1K " " " " "	2	R5, R7	0062-179B3-1XXX
1MEG " " " " "	4	R1-R4	0062-323B3-1XXX
LM556	1	U1	0508-00803-5500
7400	1	U2	0508-00803-5600
KK.156 CON. (2-PIN)	2	J1, J2	3000-16335-0200
(6-PIN)	2	J1, J2	3000-16335-0600
MOUNTING HARDWARE			
SNAP BUSHING 1/4"	4	MH1-MH4	0017-00042-0014
RAPID FIRE P.C	1	A080-91410-A000	A080-91410-A000

ASSY M051-00114-A001

THIS DWG. IS CONFIDENTIAL & PROPERTY OF MIDWAY MFG. CO.

PROJECT ENG: JERRY SZERSZEN

DIM. TOLERANCES UNLESS OTHERWISE SPEC.		FIRST USED BY <b>GALAGA</b>	
CONCENTRICITY T.I.R. .002	DATE <b>09-30-81</b>	SCALE <b>FULL</b>	
FRACTIONAL ±.1/64	MECH CHK <b>MM</b>	MATERIAL	
DECIMAL ±.005	ELEC CHK	FINISH	
HOLE DIA. +.002--0.00	DO NOT SCALE DWG		
ANGLE ±1/2°			

<b>MIDWAY MFG. CO.</b> FRANKLIN PK., IL. 60131 A BALLY CO.
<b>RAPID FIRE P.C.</b>

REVISIONS
PART NO. <b>A082-91410-A000</b>

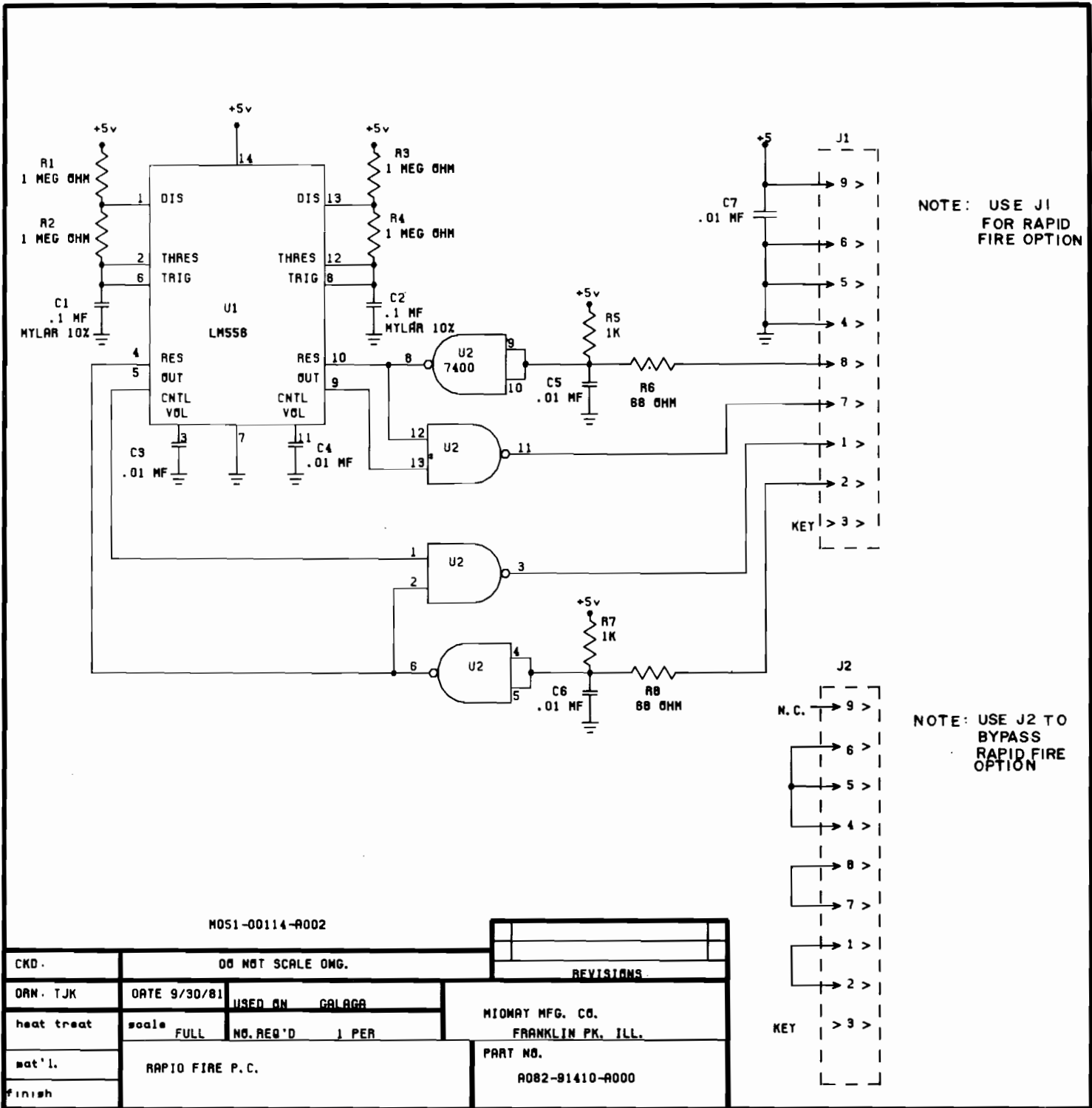

NOTE: USE J1 FOR RAPID FIRE OPTION

NOTE: USE J2 TO BYPASS RAPID FIRE OPTION

M051-00114-A002

CKD.	DD NOT SCALE DWG.		REVISIONS
ORN. TJK	DATE 9/30/81	USED ON GALAGA	MIOMAY MFG. CO. FRANKLIN PK. ILL.
heat treat	scale FULL	NO. REQ'D 1 PER	
mat'l.	RAPID FIRE P.C.		PART NO.
finish			A082-91410-A000

KEY 1 BETWEEN CONTACTS 5,E AND 6,F  
KEY 2 BETWEEN CONTACTS 3,C AND 4,D

6 5 4 3 2 1  
A B C D E F  
P Q R S T U

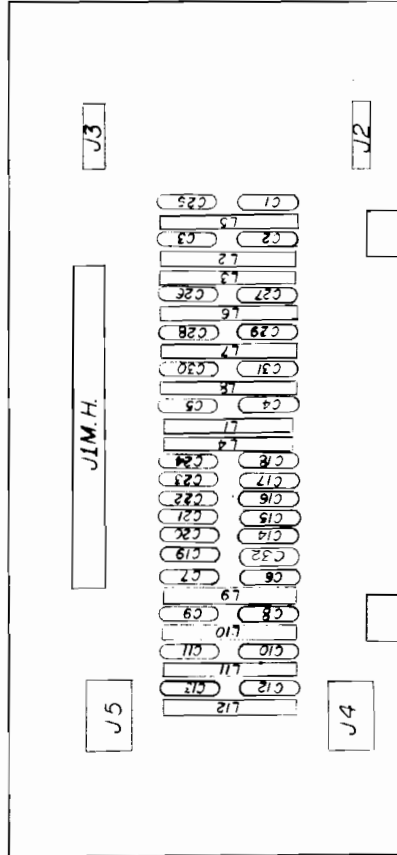

DESIGNATION	DESCRIPTION
C1	.1MF AXGER
C2-C5	47 PF AXGER
C6, C7	470 PF AXGER
C8-C13	100 PF AXGER
C14-C32	.01 MF AXGER
L1-L4	CHOKE 10JH W.W. MILLER
L5-L8	CHOKE 10JH W.W.
L9-L12	CHOKE ENCAP 1C JH
J1	P.C. EDGE CONN.
J2, J3	3 PIN HEADER
J4, J5	6 PIN HEADER
J1 M.H.	2 EDGE CONN. KEY
	(2) 6-32 x 10 SLOT PAN SCREW
	(2) WSH 6 145-250-.032
	(1) BRKT.-CONN. FIN.

DESCRIPTION	QUANTITY	DESIGNATION	PHANTOM NUMBER
47PF 50V AXGER	4	C2-C5	0508-00800-1800
100PF 50V AXGER	6	C8-C13	0508-00800-1600
470PF 50V AXGER	2	C6, C7	0508-00800-1700
.01MF 25V AXGER	19	C14-C32	0508-00800-1800
.1MF 50V AXGER	1	C1	0508-00800-0900
10 JH W.W. RF	4	L1-L4	0067-021XX-XXAX
CHOKE MILLER	4	L5-L8	0508-00804-2000
10 JH W.W. PF	4	L9-L12	0508-00804-2100
10 JH ENCAP	4		
PF CHOKE			
PC EDGE CONN.	1	J1	0017-00021-0418
3 PIN HEADER	2	J2-J3	0017-00021-0443
6 PIN HEADER	2	J4-J5	0017-0021-0424
PC EDGE CONN KEY	2	J1MH	0017-00021-0396
6-32 x 10 SLOT PAN SCREW	2	J1MH	0017-00101-0574
WSH 6	2	J1MH	0017-00104-0002
145-250-.032	2	J1MH	0017-00104-0002
BRKT.-CONN. FIN	1	J1MH	0866-0018-00XF

PROJECT ENGINEER L. DEKKER  
ASSY DWG M051-00508-B014  
THIS DWG IS CONFIDENTIAL & PROPERTY OF MIDWAY MFG CO

DATE	10-2-81	ISSUE	FULL
BY	CKS	CHKD	
APP'D		DATE	
<p>DO NOT SCALE DWG</p> <p>UNLESS OTHERWISE SPECIFIED CONCENTRICITY TOLERANCE .005 RADIUS TOLERANCE .005 HOLE DIA. TOLERANCE +.002 - .000 ANGLE TOLERANCE 1/2°</p>			
<p>ONE TO BE KEPT UNLESS OTHERWISE SPECIFIED CONCENTRICITY TOLERANCE .005 RADIUS TOLERANCE .005 HOLE DIA. TOLERANCE +.002 - .000 ANGLE TOLERANCE 1/2°</p>		<p>REVISIONS</p> <p>PART NO A 08-4 -9 -1 -4 -0 -8 -B -5 -C -8</p>	

MIDWAY MFG. CO.  
FRANKLIN, ILL. 60131  
A BALLY CO.

GALLAGA FILTER PC

TO CABLE

TO P.C. BOARD

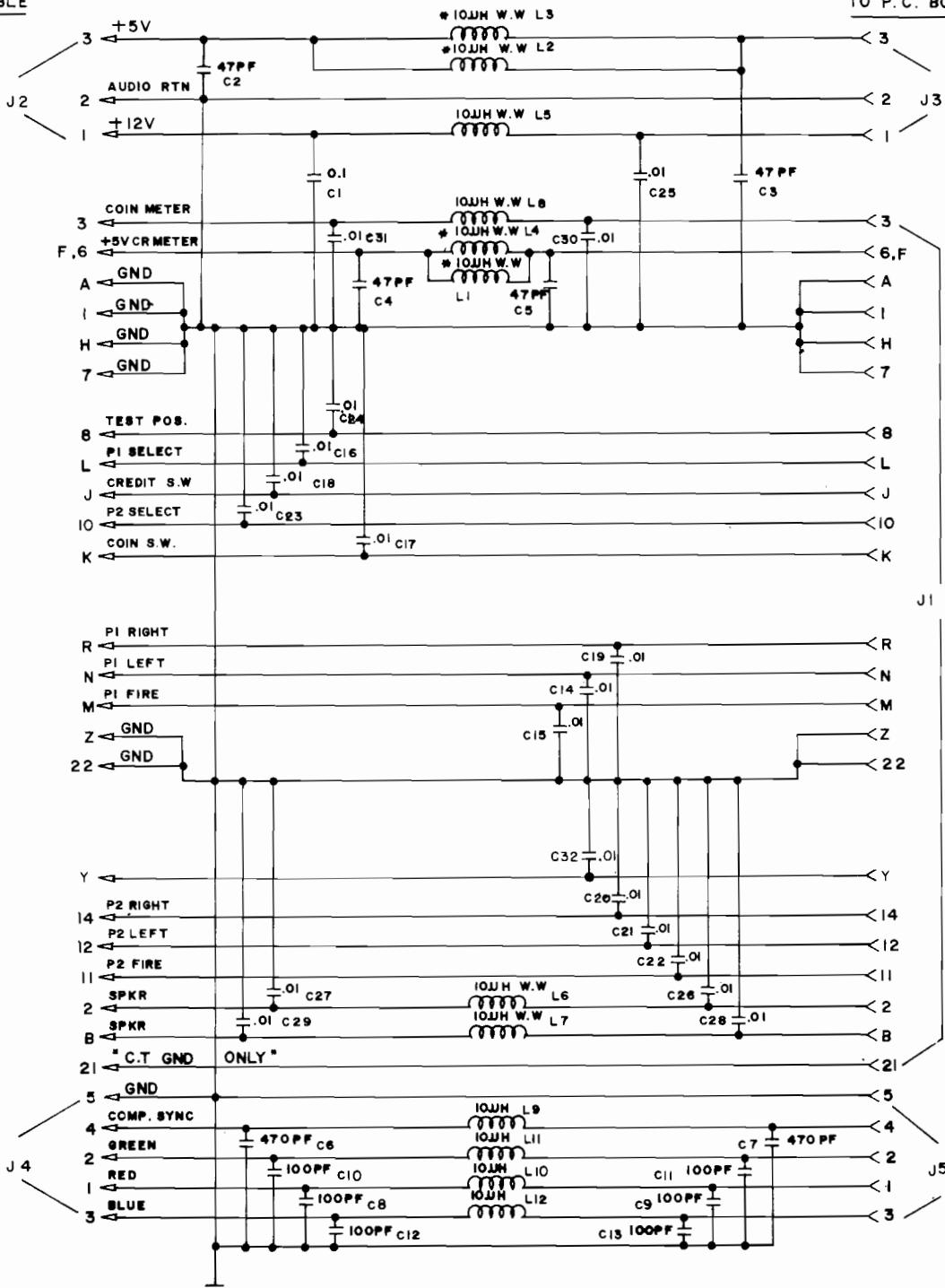

NOTE:  
 ALL .1 + .01 ARE MF  
 ALL CAPS AX. CER. UNLESS  
 NOTED OTHERWISE  
 \* 1.5 AMP (MILLER TYPE)  
 INDUCTORS

SCHEM: MOSI-00508-BO15  
 THIS DWG IS CONFIDENTIAL & PROPERTY OF MIDWAY MFG. CO.

MIDWAY MFG. CO.  
 FRANKLIN, ILL. 60131

PROJECT ENG: L. DEKKER  
 DIM TOLERANCES UNLESS OTHERWISE SPECIFIED:  
 CONCENTRICITY ± .002  
 PERIPHERAL SURF. ± .005  
 HOLE DIA. ± .002 - .000  
 ANGLE ± 10°  
 DO NOT SCALE DWG

GALAGA  
 SCALE FULL  
 70-2-81

REVISIONS  
 PART NO. AO 84 - 91 408 - 8508

GALAGA FILTER BOARD

## GALAGA LOGIC BOARD

### CHIP NUMBER

### FUNCTION

74LS00	Quad 2 Input Nand
74LS08	Quad 2 Input And
74LS10	Triple 3 Input Nand
74LS20	Dual 4 Input Nand
74LS32	Quad 2 Input Or
74LS86	Quad 2 Input Exclusive Or
74LS107	Dual "JK" Flip-Flop
74128	50 Ohm Line Driver
74LS138	3 to 8 Line Decoder
74LS139	Dual 2 to 4 Line Decoder
74LS151	8 Line to 1 Line Data Selector/Multiplexer
74LS153	Dual 4 to 1 Line Multiplexer
74LS157	Quad 2 to 1 Line Multiplexer
74LS158	Quad 2 to 1 Line Multiplexer (Inverting)
74LS161	4 Bit Binary Counter
74LS174	Hex "D" Flip-Flop
74S189	Ram 16 x 4
74LS245	Octal Buss Transceiver
74LS257	Quad Data Selector/Multiplexer
74LS259	8 Bit Addressable Latch
74LS273	Octal "D" Flip-Flop
74LS283	4 Bit Full Adder
74LS298	Quad 2 Input Multiplexer with Storage
74LS365	Hex Buss Driver
74LS367	Hex Buss Driver
74LS368	Hex Buss Driver (Inverting)
74LS377	Octal "D" Flip-Flop
74LS393	Dual 4 Bit Binary Counter
MB7052	Prom 256 X 4 (GG1-1 thru GG1-5)
MB2147	Ram 4K X 1
MB8147	Ram 4K X 1
UPD2114	Ram 1K X 4
MB8532	Eprom 4K X 8
HN462732	Eprom 4K X 8
Z80A or D780C-1	CPU (must use at location 4M)
D780C	CPU (may substitute Z80)
4066	Quad Bilateral Switch
MB3730	Audio Amplifier
LM324	Quad Operational Amplifier
02XX	Custom Data Buffer
04XX	Custom Address Buffer
00XX	Custom Address Generator
05XX	Custom Video Controller
07XX	Custom Horizontal and Vertical Sync. Generators
08XX	Custom Buss Transceivers
51XX	Custom I/O Ports
54XX	Custom Sound Generator
TMM2016	RAM 2K X 8
06XX	Custom Master Buss Controller
18.432	X-tal

## ADDITIONAL DEVICES

CHIP NUMBER	FUNCTION	
2SC1815	Transistor	NPN
2N3391	Transistor	NPN
D998	Transistor	NPN
C2500	Transistor	NPN
TIP 110	Transistor	NPN
A733	Transistor	PNP
2N4403	Transistor	PNP
1N4004	Diode	
1N914B	Diode	