

KONAMI[®]



OPERATOR'S MANUAL



WARNING

GTI CLUB[™] IS AN ORIGINAL GAME DEVELOPED BY KONAMI CO. LTD
KONAMI CO. LTD RESERVES ALL THE COPYRIGHTS, TRADEMARKS AND OTHER INDUSTRIAL
PROPERTY RIGHTS WITH RESPECT TO THIS GAME

Part No: 64353

GTI CLUB DELUXE™

CONTENTS

	Page No.
□ About this product	1
□ Precautions for use	2
1 Machine installation	
1.1 Connecting the units	7
1.2 Fastening the adjusters	9
1.3 Service Panel	10
1.4 Separating and moving the units	11
2 How to play	12
3 Networking game machines and PCB settings	
3.1 How to network game machines	14
3.2 PCB start-up check (self test)	15
3.3 Correcting the positions of steering wheel etc.	16
3.4 Adjusting the game position (manual test)	17
3.5 Mode descriptions	18
3.6 Network abnormality counter measures	26
4 Maintenance and annex	
4.1 Replacing the coin acceptor	28
4.2 Replacing the fluorescent light	31
4.3 Replacing and adjusting the potentiometer	33
4.4 Replacing the gear shift unit switch	40
4.5 Replacing the timing belt and adjusting the tension	41
4.6 Adjusting the projector	43
4.7 Potentiometer wiring information	49

GTI CLUB DELUXE™

CONTENTS

	Page No.
Appendix A Credit board settings	50
Appendix B Names of parts and list of main parts	57
Appendix C Wiring schematic - Main Unit	62

While the information contained in this manual is given in good faith and was accurate at the time of publication, KONAMI CO. Ltd reserve the right to make changes and alteration without prior notice.

This equipment has been manufactured in accordance with the European Community Directive, and as such bears the CE marking. Any changes or modifications made to this equipment must be in accordance with the European Community Directive. If you make unauthorised changes to this equipment, you contravene the European Community Directive.

Under some conditions of extreme external interference, e.g. Radio Transmissions, Electrostatic Discharge or Mains Transients, may cause degradation of performance. However the equipment will recover normal performance once the source of interference has ceased or been removed.

Certain component parts of this equipment are critical to ensure conformance to the European Community Directive, and therefore must only be replaced with parts as those specified.

□ About this product

Thank you for purchasing this Konami product. This manual explains how to operate your gaming machine correctly.



Failure to operate the machine correctly could result in malfunction or accidents, so please read this manual carefully before commencing operation. Be sure to operate the machine as described in this manual. Please ensure this manual is always kept with the machine.

- The specifications of this product are subject to change without notice for reasons such as improving the performance
- The contents of this game, its main data and design are protected by copyright law industrial property law.
- Unauthorised reproduction of this document or any of its contents is strictly forbidden.

© 1996 KONAMI ALL RIGHTS RESERVED

Precautions for use

In this manual, the precautions will be followed without fail in order to prevent damage to persons to install, use or maintain "GTI CLUB™" or other persons or to properties are shown as follows.

Be sure to read the following

- The following suggestions show the degree of danger and damage caused when the product is used improperly with the suggestions disregarded.



WARNING!

Indicates a situation where disregarding the suggestions could result in death or serious injury.



CAUTION!

Indicates a situation where disregarding the suggestions could result in injury or product damage

- The following graphic suggestions describe the types of precautions to be followed.



Indicates a matter of which care should be taken



Indicates a matter which is forbidden



Indicates a matter which should be performed without fail

• Setting Up





Warning!

- Be sure to consult your nearest dealer when setting up, moving or transporting this product.
 - » This product should not be set up, moved or transported by anyone other than industry specialists. Doing so could result in injury or product damage.
 - » When setting up this product, fasten the game machine securely with all the adjusters. If the game machine is not fastened securely, injury or accidents could be caused by the machine rocking.
 - » When setting up this product, take care that no undue force is applied to the connecting sections of the game machine. Failure to do so could cause injury, accidents or product damage.

- This product is an indoor game machine. Never set up the game machine outside. 
 - » Setting up this product outside could result in accidents or equipment failure.

- Do not set up the game machine near emergency exits. 
 - » Doing so could block exits in time of emergency and could result in death or serious injury.

- Do not set up the game machine:
 - ... in a place exposed to rain or to moisture
 - ... in a place exposed to direct sunlight
 - ... in a place exposed to direct heat from air-conditioning and heating equipment etc.
 - ... near hazardous flammable substances such as thinners and kerosene
 - ... on an inclined or uneven floor
 - ... near fire extinguishing equipment
 - ... in a place exposed to strong vibration
 - ... in a place exposed to excessive dust
 - ... near equipment generating strong magnetism or electric waves¹

- Do not place containers holding chemicals or water on or near the game machine. 
 - » Electric shock or damage could be caused by water or foreign matter entering the inside of the machine.

- Do not place items near the ventilating holes. 
 - » Doing so could cause the internal temperature to rise excessively, resulting in equipment damage.

- Do not bend the power cord by force or place heavy objects on it. 
 - » Doing so could result in electric leakage or fire.

- Never plug or unplug the power cord with wet hands. 
 - » Doing so could result in electric shock.

- Never unplug by pulling the power cord 
 - » Doing so could damage the cord, resulting in electrical leakage or fire.

- Use an earthing band or similar means of discharging static electricity when adjusting the PCB DIP switches.
 - » If not discharged, static electricity could damage the electronic components on the board.

¹ Check with EMC guidelines on siting this equipment. All machines should now bear the CE mark for approval. This mark states that all emissions are within those specified by the regulatory body.

• Setting Up



Caution!

- Be sure to use indoor wiring for within the specified voltage range. For extension cord, use indoor wiring of the specified rating or more.
 - » Failure to do so could result in fire or equipment failure.
- Never plug more than one cord at a time into the electrical receptacle.
 - » Doing so could result in fire or electric shock.
- Do not lay the power cord and the communication cable where people walk through. You may tread or stumble over them.
 - » You may stumble down and get injured, or damage the cord or cable.
- Do not place heavy objects on or pull on the pipe connecting the projector unit and drive unit. Also do not use the game machine with the pipe removed and the wiring exposed.
 - » Doing so could result in equipment failure.
- Make sure the machine has been earthed properly before using the machine.
- Clearances of 100mm (3.94in) or more should be created between the game machine and walls.

• Operation



Warning!

- Do not use this product anywhere other than industrial areas.
 - » Use in a residential area or an area next to a residential area could affect signal reception of radios, television sets, telephones, etc.
- If there is any abnormality such as smoke, bad smell or abnormal noise being emitted from the machine, immediately unplug the power cord and stop operating the machine.
 - » Using the machine in abnormal conditions could result in fire or accidents

In case of abnormality:

- 1 - Turn off the power
- 2 - Unplug the power cord
- 3 - Contact your nearest dealer

- Do not leave the power cord plugged improperly or covered with dust.
 - » Doing so could result in electrical shock or fire, so inspect the power cord periodically.
- Never disassemble, repair or modify any section other than those specified in this manual.
 - » Doing so could result in fire, malfunction or equipment failure.

• Operation



Caution!

- The following users should not play the game:
 - » Doing so could cause accidents or illness.



• Those under the influence of alcohol

• Those suffering from or being treated for arm or wrist ailments

- Do not plug or unplug the power cord with wet hands.
 - » Doing so could result in electric shock.



- When handling the power cord, take care of the following:
 - » Improper handling could result in fire or electric shock.



• Do not damage the power cord
• Do not bend the power cord excessively
• Do not heat the power cord
• Do not bind the power cord
• Do not sandwich the power cord

• Do not modify the power cord
• Do not twist the power cord
• Do not pull the power cord
• Do not tread on the power cord
• Do not drive a nail into the power cord.

- If the power cord or power plug becomes damaged, stop using the machine immediately.
 - » Using a damaged power cord or power plug could result in fire or electrical shock.

- Do not place items or heavy loads on or provide a strong impact to the moulding.
 - » Doing so could cause the object on the machine to fall off or could damage the machine, resulting in injury.



• Inspection and cleaning



Warning!

- Be sure to turn off the power and unplug the power cord from the receptacle before inspecting or cleaning the machine.
 - » Failure to do so could result in electrical shock.



- When replacing parts, be sure to use parts of the correct specifications. Never use parts other than the specified ones.
 - » Using improper parts could result in fire or equipment failure.



- Never disassemble, repair or modify any section other than those specified in this manual.
 - » Doing so could result in fire, malfunction or equipment failure.



- To clean the game machine, wipe it with a soft cloth dampened in a neutral detergent and wrung out.

- » Using organic solvents such as thinners may corrode the materials.
- » Electrical shock or equipment failure could be caused by water entering the inside of the machine.

• Moving and Transportation



Caution!

• The game machine contains parts such as a projector, electronic components and precision components which are sensitive to vibration and impact. Great care therefore should be taken when moving and transporting the game machine. Be sure not to let the machine tip over. 

• Fully raise all the adjusters before moving the game machine and move it utilising the casters. Be sure to turn off the power and unplug the power cord from the receptacles before moving the game machine. 

» Failure to do so could result in accidents, damage or equipment failure.

• Take care that no undue force is applied to the connecting sections of the game machine when moving it.

» Failure to do so could cause injury, accidents or product damage.

• Disposal



Warning!

• When disposing of the projector unit, do not leave it with the screen exposed. 

» Doing so could result in fire due to direct sunlight

• If the screen is removed, be careful not leave it in direct sunlight. 

» Doing so could cause burns or fire.

Precautions in Handling



• When setting up, handling, inspecting, maintaining, moving or transporting this product, follow the procedures and instructions set forth in this manual and perform such work safely.

• Do not remove labels of "Warning", "Caution", etc. attached to the product.

• Do not set up, handle, maintain, move or transport this product under conditions specified in any of the previous sections.

• If a new owner is to have this product as a result of transfer, etc. be sure to give this manual to the new owner.

1 Machine Installation

1.1. How to connect the units



- Do not move the units by pulling the cables coming out of the drive unit or projector unit, or the connectors and connection pipes
- When connecting the drive unit or installing the connector cover, take care not to catch the wiring

1. Align drive unit A and drive unit B and temporarily fasten the attached unit connecting plate.*

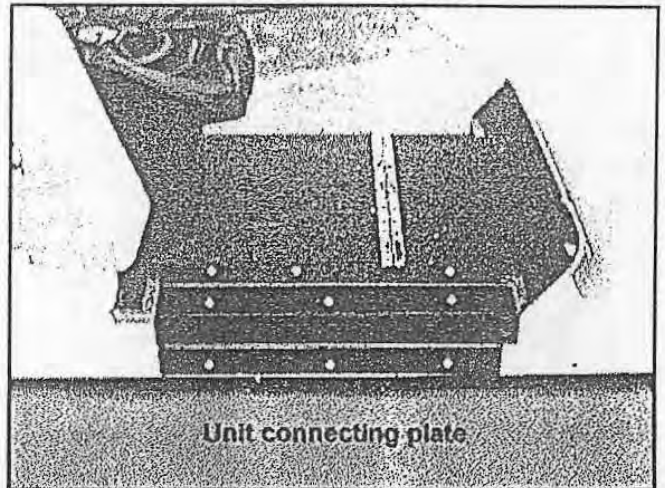

2. Connect the connectors of drive unit A with the connectors of the handbrake unit.

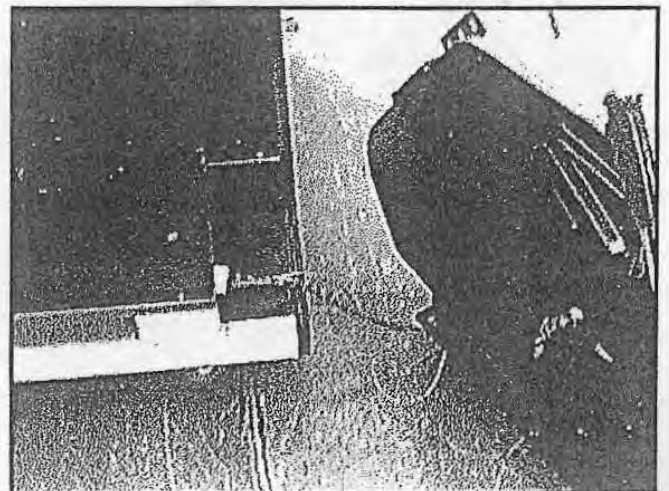

* The temporarily - fastened unit connecting plate and joint fitting should be fastened securely after the completion of "1.2 Fastening the adjusters" on page 9

3. Temporarily fasten the attached joint fittings to secure the handbrake unit.*

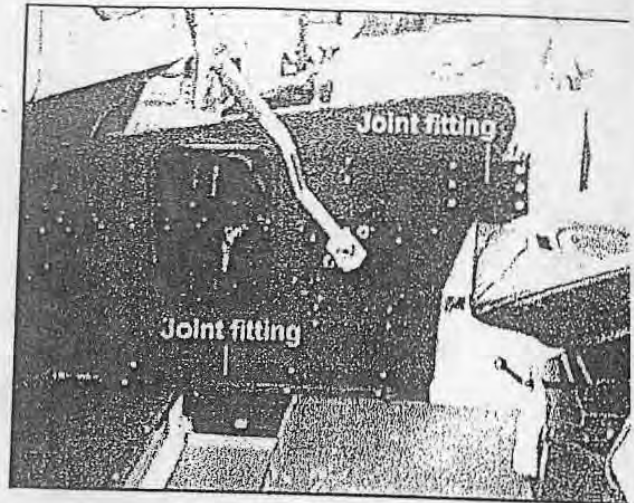

4. Connect the connectors of drive unit A with the connectors of the connection pipe, and install the connector cover using the attached screws.

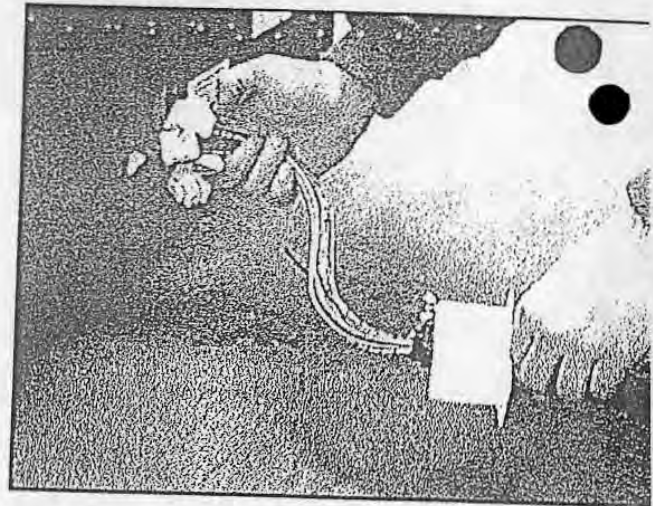

5. Connect the projector unit connector to the connection pipe connector, and install the connector cover using the attached screws.

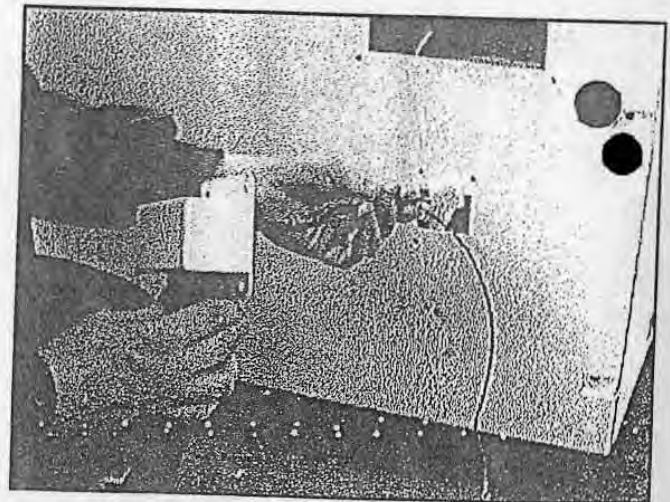

* The temporarily - fastened unit connecting plate and joint fitting should be fastened securely after the completion of "1.2 Fastening the adjusters" on page 9

1.2 Fastening the adjusters



- Adjust the adjusters so that the castors do not touch the floor. Take care not to exceed the maximum adjusting height of the adjuster.
- After checking that all the adjusters stand on the floor and the units do not wobble, tighten the hexagon nuts upward.

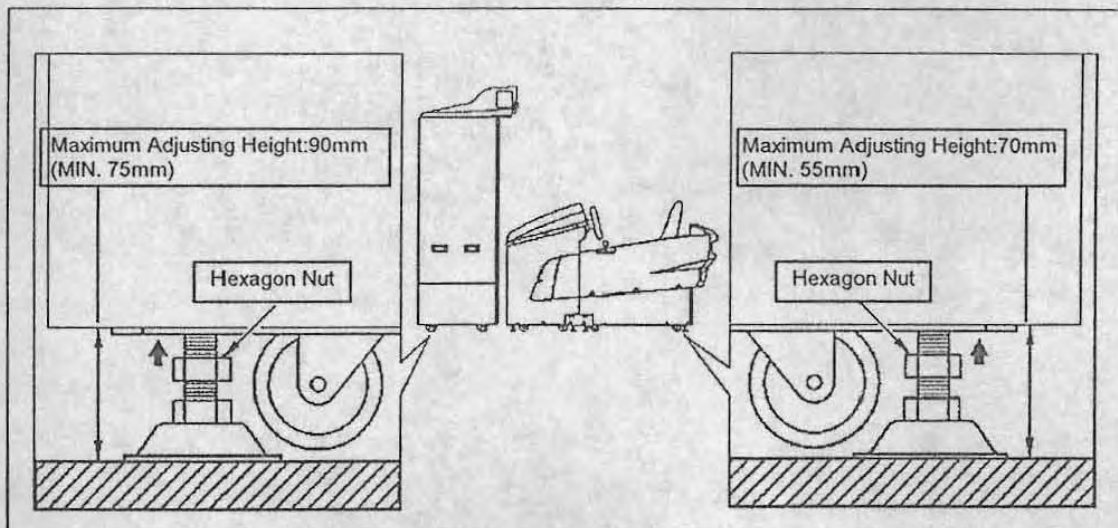

1.3 Service Panel

You will find the service panel when the maintenance door is opened with the attached maintenance key.



Figure 2 Open service door on Handbrake Unit

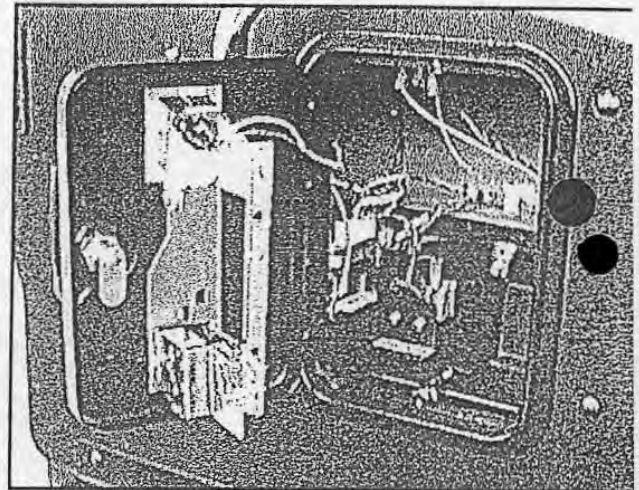

Figure 3 Service Panel is located inside

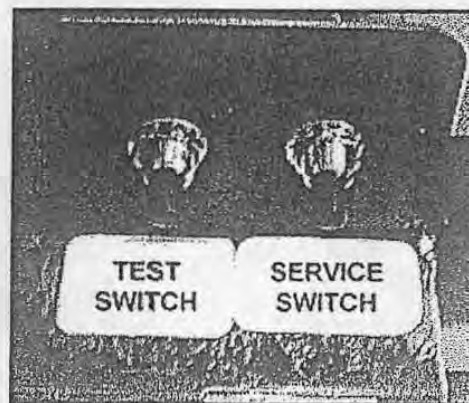

Figure 4 Service Panel Detail

1.4 Separating and moving the units

The units of the machine can be separated.

• How to remove the units



- Before separating the units from the machine, be sure to turn off power switch and remove the power cord from the receptacle.
- Move the game machine, after making sure that the drive unit and projector unit are separated.
- When connecting the separated units, take care not to catch the wiring between the units
- These machine units are heavy, take care not to trap hands or fingers when moving the machine

1.
Turn off power switch and remove power cord plug from the receptacle.

2.
Remove the connector cover and disconnect the connectors.*
Take care to disconnect the earth wire before separating the units.

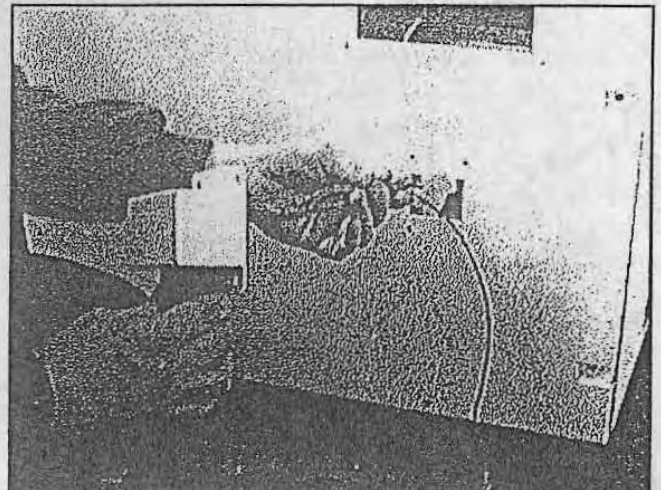

3.
Loosen all the adjusters and move the units utilising the castors.

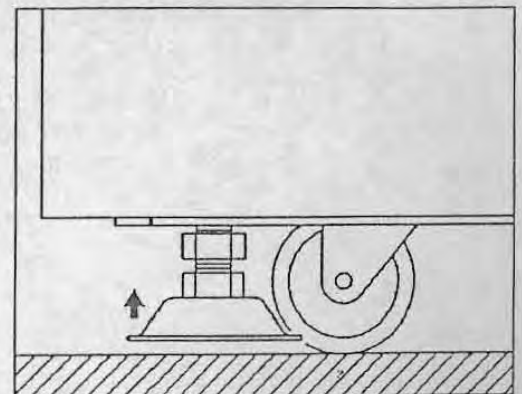

* If you have to separate the drive unit, remove the unit connecting plate and joint fitting, loosen the adjusters, and separate drive unit A and drive unit B from the machine.

2 How to play

This machine simulates a driving game in which eight small rally cars (one of which is to be selected by the player and the other rival cars) compete against each other through a virtual urban area, as if the player is racing through a beautiful resort town in southern France.

This machine allows the player to enjoy a thrilling driving game while controlling his car, complete with realistic "quick turn" & " drift driving " using the handbrake lever. The machine can also be linked up to a maximum of 4 networks, increasing the realism and enjoyment for the player.

• How to play

1. Insert a coin into the slot to start the game. (In free play mode push the VIEW SHIFT button to start the game).
2. The **Network Entry Screen** appears. If a coin is put in another machine which is connected this machine through the network, during this period, the network race starts automatically.
 - ⊕ *If the machine is not connected to the network or it is impossible for the player to play because someone else is playing the game, proceed to the operation in the following item 3 after a coin is inserted*
3. Select the player car on the **Machine Select Screen**. Select desired car by turning the steering wheel and the stepping on the accelerator.
4. The screen changes to the **Game Select Screen**. Then, make the game mode selection from the following modes. Select the desired mode by turning the steering wheel and stepping on the accelerator.
 - **Beginners Mode** A part of the urban area in the map of entire courses is made into a circuit, where the player plays a circuit race.
 - **Advanced mode** All the roads are made open, and the player plays circuit race whilst looking for the shortest and fastest route. This mode is for an expert player.
 - **Super - Advanced mode** The player plays the circuit race in the reverse course to that of advanced mode. This mode is for a super-expert player who wants to challenge an extremely difficult course where a labyrinth of roads is running.
 - **Special mode** This mode can only be selected when in network play. The player can enjoy a car racing " Tag " in a closed urban area.
5. When the selection from the above modes is over, the game starts. The game begins when the countdown has ended on the screen.
6. The basic control is performed by the following equipment:
 - **Steering wheel** Running direction can be controlled by turning the wheel right or left.
 - **Accelerator** Depressing the pedal accelerates and releasing the pedal decelerates the car speed.
 - **Brake** Depressing the pedal brakes the car.
 - **Hand brake** When it is pulled up, the rear wheels are locked and skidding for " Quick Turn "

- Shift Operation Manual operation (MT) or automatic operation (AT) can be selected. Switching over to MT or AT can be performed by pressing the button at any time during play:-
- View Shift Pressing the VIEW SHIFT button enables the player to select three different kinds of view, at any time during play - Rear View / Distant View / Driver's View
In special mode, the " Super Distant View " is exclusively set and the player can not select any other views than this.

7. The rules for each mode are as follows.

- Beginner's / Advanced / Super-advanced modes

The remaining play time is added whenever the player's car passes each check point in the course. The game ends either when the player's car has run the whole pre-set course or when the play time is up.

The ranking, entire route travelled and the point reached at that time are displayed on the map when the game is over.

When the player's car has run the whole distance in the race, the entire route travelled by the player's car is replayed on the screen, and the ranking, total lap time and course record are displayed. Name entry is possible only when the player has renewed the course record.

- Special mode

A " Bomb Mark " is attached to only one of the participant cars, which becomes the "tagger" in tag. When the "tagger" bumps any one of the competitors cars, the " Bomb Mark " is handed over to the bumped car. The player who has the " Bomb Mark " on his car at the time when the limited time is up loses the game.

- Buy in during game

In GTI CLUB™, no buy in is allowed.

- Player car

One " Player's Car " can be selected out of the total five cars including four small cars and premium car (super car).

There is no difference in performance among the small cars, but the premium car has greater acceleration performance. The play fee may be set higher only for the premium car.

- Rival cars

The " Rival Cars " are composed of the small cars which have not been selected (except the premium car) and an additional four rival cars.

3 Networking game machines and PCB settings

3.1 How to network the game machines

The specification of GTI CLUB™ allows up to four game machines to be connected so that players can enjoy 'versus' games. To network, connect the networking cord supplied with each game machine to the network pin jack of the projector unit after setting up the game machines (see previous section).



- When using the game machine independently, do not connect anything to the pin jack.
- Game machines are linked together in a chain with the network cords. Do not connect anything to the first and last pin jacks in the chain
- When networking game machines, set the PCB main board dip switch "network ID" while referring to "DIP SWITCH SETTINGS" on page 15

- Networking four machines

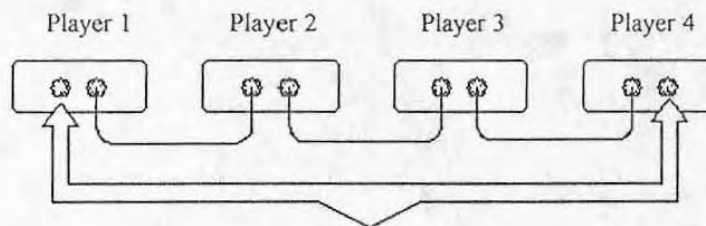

Do not connect anything to the pin jacks at the both ends of the first and last machines

3.2 PCB start-up check (self test)

- When the power switch is turned ON after the installation of the machine, the performance of the PCB is checked automatically. The result is displayed on the screen.



• Be sure to perform the self test before using the machine. If an abnormality persists or the machine does not operate properly, turn OFF the power switch immediately to stop operating the machine

- Result of Test

If test is OK,

- The position of steering wheel is corrected automatically.

If any abnormality is detected,

"BAD" appears on the screen, and the checking is repeated.

If "24G BAD" is displayed, once turn OFF the power switch and then turn it ON again whilst depressing the test switch button on the service panel.

The content of setting in manual test and the course record return to those having been set at the time of shipment.

After the machine is installed, or PCB is repaired or replaced, once return the content of setting to those having been set at the time of shipment by turning ON the power switch while depressing the test switch of the service panel. If the abnormality indication still appears or the machine does not operate normally, turn OFF the power switch immediately to stop operating the machine.

3.3 Correcting the positions of the steering wheel etc.

• After the self test, the positions of the following equipment are corrected automatically - Steering Wheel / Hand Brake / Accelerator / Brake
At this time, the message " DO NOT TOUCH THE CONTROL DEVICE WHEN THE MACHINE IS BEING INITIALISED. " appears on the screen. Refrain from touching the steering wheel, handbrake, accelerator or brake as long as this message appears. The steering wheel turns a few times to the left or right automatically.

• Result of position check

If the result is OK,

• When the position check is over, the operation mode returns automatically to the game mode.

If the result is abnormal

The result of check is displayed as follows on the screen.

• Steering wheel abnormal, the message " Device Error (STEERING WHEEL) " appears on the screen.

What to do The steering wheel control exceeds the correctable range or the steering wheel reaction device is out of order. Make the adjustable by referring to "4.3 Adjusting the potentiometer " on pages 33 & 34

• Hand brake abnormal, the message " Device Error (HAND BRAKE) " appears on the screen .

What to do The hand brake control exceeds the correctable range.
Make the adjustment by referring to "4.3 Adjusting the potentiometer " on pages 37, 38 & 39

• Accelerator abnormal, the message " Device Error (ACCEL) " appears on the screen.

What to do The accelerator control exceeds the correctable range.
Make the adjustment by referring to "4.3 Adjusting the potentiometer " on pages 35 & 36

• Brake abnormal, the message " Device Error (BRAKE) " appears on the screen.

What to do The accelerator control exceeds the correctable range.
Make the adjustment by referring to "4.3 Adjusting the potentiometer " on pages 35 & 36

When any of the above signs appear, push the test switch on the service panel to go to the manual test mode.

Then choose "I/O CHECK" to check the device which shows the error. In case the DEVICE ERROR is still displayed after the readjustment, there may be something wrong with it. *Turn the power off immediately.*

If the " GAME MODE " is selected on the " MAIN MENU " screen, whilst the controls are in a faulty condition, the game will not play properly.

If an error sign is displayed, or the device doesn't work correctly turn off the power switch immediately.

3.4 Adjusting the game environment (manual test)

Manually check and change the settings for the screen display and game contents.

• To start the manual test mode

1. Turn on power switch
2. Press the test switch on the service panel during the game demo mode.²
If you are working with networked machines, you must have all four machines in demo mode before the test switch will take effect.
3. The unit is now in the manual test mode and the main menu is displayed on screen.

• To quit the manual test mode

1. Choose the " GAME MODE " from the main menu using the shift lever.
2. Push the " VIEW " shift switch.

The game then returns to normal game mode.

• Main Menu

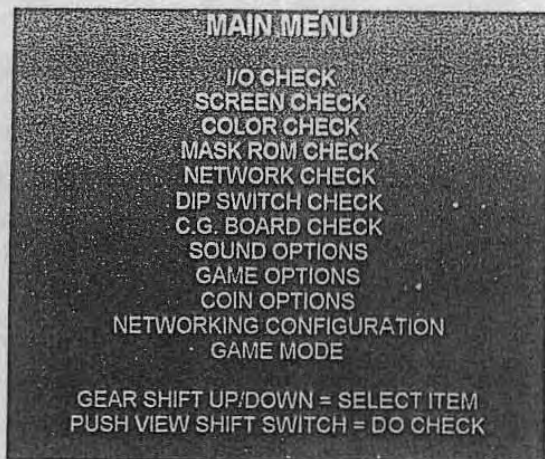

- Check each controller, page 18
- Adjust screen distortion, page 19
- Adjust color, page 19
- Check mask ROM, page 19
- Check network, page 20
- Set DIP switches, page 22
- Check CG board functions, page 22
- Adjust sound volume, etc, page 23
- Set difficulty etc., page 23
- Coin settings, page 24
- Network settings, page 25
- Return to game mode

• Selecting each mode

How to select each mode from menu

Select ⇒ Move the shift lever up or down

Set ⇒ Push the VIEW shift switch

After selecting a mode, refer to the page on which that mode is described in details.

² Turning ON the power whilst depressing the test switch will return all manual settings to their factory preset setting.

3.5 Mode descriptions

- The original factory settings are displayed in green; the changed settings are displayed in red.
- After completion of the setting change, select "SAVE AND EXIT" and push the VIEW shift switch. Then, the settings are saved automatically and the screen returns to the main menu.
- If "EXIT" is selected after the completion of setting change, the following message will appear:- "YOU DID NOT SAVE. DO YOU WANT TO SAVE? YES/NO"
- If "YES" is selected, the message "NOW SAVING" will appear, the changed settings will be saved and you will be returned to the main menu.
- If "NO" is selected, the message "NO MODIFICATION" will appear and the changed settings will not be saved.
- If "FACTORY SETTINGS" is selected and the VIEW shift switch is pressed, all the settings will return to the original settings that have been made at the time of shipment.

I/O CHECK

- The check mode for the controls.

To return to the main menu screen, move up the gear shift lever while pushing the VIEW shift switch.

Shows the value for the steering wheel in decimal (HEX)

Shows the value for the Hand brake in decimal (HEX)

Shows the value for the Accelerator Pedal in decimal (HEX)

Shows the value for the Brake in decimal (HEX)

I/O CHECK

VIEW SHIFT SWITCH OFF GEAR SHIFT SWITCH OFF AT/MT SHIFT SWITCH OFF	COIN MECH SWITCH OFF SERVICE SWITCH OFF TEST SWITCH OFF																																
STEERING WHEEL +00000 (00000) HAND BRAKE 00000 (00000) ACCEL 00000 (00000) BRAKE 00000 (00000)	<table style="margin: auto; border-collapse: collapse;"> <tr> <td></td> <td style="padding: 0 5px;">left</td> <td style="padding: 0 10px;">centre</td> <td style="padding: 0 5px;">right</td> </tr> <tr> <td style="text-align: center;">+--+----- -----+--+</td> <td></td> <td></td> <td></td> </tr> <tr> <td style="text-align: center;">min</td> <td></td> <td></td> <td style="text-align: center;">max</td> </tr> <tr> <td style="text-align: center;"> --+-----+-----+--+</td> <td></td> <td></td> <td></td> </tr> <tr> <td style="text-align: center;">min</td> <td></td> <td></td> <td style="text-align: center;">max</td> </tr> <tr> <td style="text-align: center;"> --+-----+-----+--+</td> <td></td> <td></td> <td></td> </tr> <tr> <td style="text-align: center;">min</td> <td></td> <td></td> <td style="text-align: center;">max</td> </tr> <tr> <td style="text-align: center;"> --+-----+-----+--+</td> <td></td> <td></td> <td></td> </tr> </table>		left	centre	right	+--+----- -----+--+				min			max	--+-----+-----+--+				min			max	--+-----+-----+--+				min			max	--+-----+-----+--+			
	left	centre	right																														
+--+----- -----+--+																																	
min			max																														
--+-----+-----+--+																																	
min			max																														
--+-----+-----+--+																																	
min			max																														
--+-----+-----+--+																																	
HOLD VIEW SHIFT SWITCH & GEAR SHIFT DOWN = ACTIVE STEERING WHEEL TEST HOLD VIEW SHIFT SWITCH & GEAR SHIFT UP = EXIT																																	

The marker position changes show the input value.

Check the steering wheel reaction device. The steering wheel turn automatically clockwise and counterclockwise during check. Make sure the "| " moves according and the meter value changes during the test procedure. Do not touch steering wheel during this procedure.

- If the steering wheel or the accelerator is not properly adjusted, make the necessary adjustments while referring to "4.3 Replacing and adjusting the potentiometer", on pages 33 to 39

• Screen Check

- Adjust the focus, distortion of the screen while watching the grill on the screen. Use projector control PCB (See page 46.) to make the adjustment. To return to the main menu, push the VIEW shift switch

• Color Check

- Make the adjustment using the projector control PCB (mounted behind the access plate on the projector unit), so that the colours of the colour bar should be displayed in discrete gradation. To return to the main menu, push the VIEW shift switch.

• Mask ROM check

- Mask ROMs are checked one by one, and when no abnormality is found, " OK " is displayed. If any abnormality is found, " BAD " is displayed. To start checking, push the AT / MT shift switch. To return to the main menu, push the VIEW shift switch.

• Network Check

• Turn all machines that are connected with the network cables to this mode, observe the screen for at least one minute. The machines should satisfy the following three conditions.

To return to the main menu, push the VIEW shift switch.



• If any of the three conditions are incorrect, it indicates possible communication malfunction. Take measures while referring to " 3.6 Network abnormality counter measures " on page 26. If the same symptom persists in spite of taking measures or a problem occurs that is not covered by this manual, turn off the power switch immediately and do not operate the machine.

• Network Check screen

NETWORK CHECK			
This BOARD-ID is 3			
	ERROR	DOWN	STATUS
ID No.1	0	0	DNC
ID No.2	0	0	DNC
ID No.3	0	0	
ID No.4	0	0	DNC

PUSH VIEW SHIFT SWITCH = EXIT

Shows the " Network ID " of the connected game machine. (1 - 4)

" DNC " (did not connect) appears if network connection is not made

• Check Items

- ✓ Check that the " | " mark in the STATUS column is moving from the left to the right at a fixed speed
- ✓ Check that the value in the ERROR column is below " 10 " after one minute
- ✓ Check that the value in the DOWN column does not change from " 0 "

- Screen display when game machines are networked

- Two game machines are networked

Screen for player 1

NETWORK CHECK			
This BOARD-ID is 1			
	ERROR	DOWN	STATUS
ID No.1	0	0	
ID No.2	0	0	
ID No.3	0	0	DNC
ID No.4	0	0	DNC
PUSH VIEW SHIFT SWITCH = EXIT			

Screen for player 2

NETWORK CHECK			
This BOARD-ID is 2			
	ERROR	DOWN	STATUS
ID No.1	0	0	
ID No.2	0	0	
ID No.3	0	0	DNC
ID No.4	0	0	DNC
PUSH VIEW SHIFT SWITCH = EXIT			

- Four game machines are networked

Screen for player 1

NETWORK CHECK			
This BOARD-ID is 1			
	ERROR	DOWN	STATUS
ID No.1	0	0	
ID No.2	0	0	
ID No.3	0	0	
ID No.4	0	0	
PUSH VIEW SHIFT SWITCH = EXIT			

Screen for player 2

NETWORK CHECK			
This BOARD-ID is 2			
	ERROR	DOWN	STATUS
ID No.1	0	0	
ID No.2	0	0	
ID No.3	0	0	
ID No.4	0	0	
PUSH VIEW SHIFT SWITCH = EXIT			

Screen for player 3

NETWORK CHECK			
This BOARD-ID is 3			
	ERROR	DOWN	STATUS
ID No.1	0	0	
ID No.2	0	0	
ID No.3	0	0	
ID No.4	0	0	
PUSH VIEW SHIFT SWITCH = EXIT			

Screen for player 4

NETWORK CHECK			
This BOARD-ID is 4			
	ERROR	DOWN	STATUS
ID No.1	0	0	
ID No.2	0	0	
ID No.3	0	0	
ID No.4	0	0	
PUSH VIEW SHIFT SWITCH = EXIT			

• DIP Switch Settings

- The DIP switch setting mode

When changing the dip switch settings, set the DIP switch by referring to the chart below.

To return to the main menu, push the VIEW shift switch.



- Be sure to turn OFF the power switch before setting the DIP switch
- Generation of static electricity may cause breakage of electronic parts on the PCB. Be sure to eliminate static electricity by means of the earthing band.

- DIP switch setting chart

- Main board (upper PCB) DIP switch

- Set all the DIP switches on the CG board to OFF

SETTING		1	2	3	4
	First machine	OFF	OFF		
NETWORK ID	Second machine	ON	OFF		
	Third machine	OFF	ON		
	Fourth machine	ON	ON		
	Not in use (Be sure to set it OFF.)			OFF	OFF

- When setting DIP switch of networking game machines, number each switch in the sequence of the small number (Eg. When networking two game machines, set the network ID of the one machine to 1 and the other to 2.)

- The DIP switch on the PCB can be shifted easily by utilising a thin flatblade screwdriver or a ball point pen.

• CG Board Check

- The CG board function check mode.

Observe the screen in this mode to check whether the CG board is functioning correctly.

To return to the main menu, push the VIEW shift switch

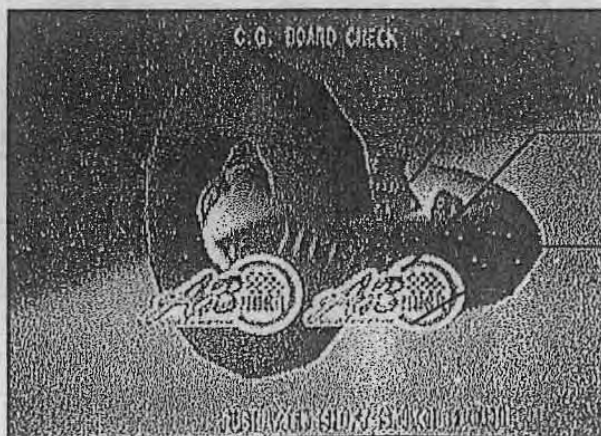

Two toruses (doughnut-shape bodies) are rotating

Two "A&B Product" logos displayed in front of the torus are flickering alternating.

Two backgrounds are displayed at the back of the rotating toruses.

• Sound Options

- The following screen appears when this mode is selected

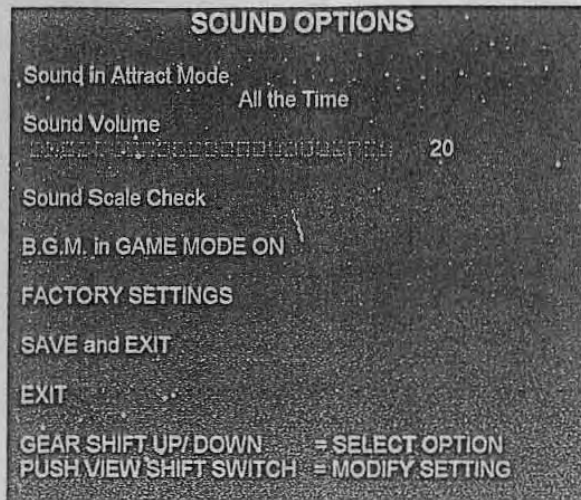

- Turns the demo sound On or OFF
 - ALL THE TIME - Sound always ON
 - ONCE EVERY 4 CYCLES - Sound ON every
 - COMPLETELY OFF - Sound always off
- Adjusts the volume from 0 (min) to 30 (max)
- You will hear a do-re-mi musical scale from the right speaker, this is repeated twice.
- Turns the BGM during the game ON or OFF
Note: This is only for the BackGround Music during game mode.
- Returns all the settings to the factory settings at the time of shipment

• Game Options

- The following screen appears when this mode is selected.

- When connecting the machines to the network communication, be sure to set all the PCBs to the same configuration.

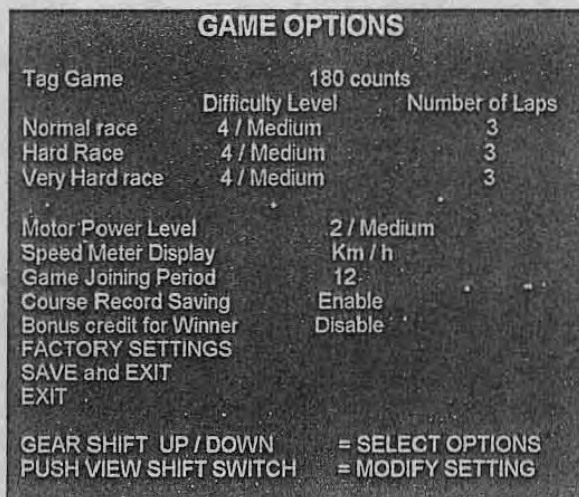

- Time limits of special modes: 100, 120, 140, 160, 180, 200, 220, 240
- Difficulty Level settings
EASIEST ↔ HARDEST
- Sets circulation frequency (2, 3, 4 times)
- Sets Force of Steering wheel reaction force
LIGHT ↔ VERY HEAVY
- Switches the speedometer display KM/H or MPH
- 4, 8, 12, 16 seconds
- Record the course record. When " Disabled " is selected, the course record is not recorded nor initialised.
- When " Enable " is selected, 1 credit is added to the top ranking machine in the network.

- If the setting of circulation frequency for a course is changed and saved the course record is re-initialised.

• Coin Options

• The following screen appears when this mode is selected.



Note: The coin setting options are not displayed if the FREE PLAY option is enabled.



- Always keep set to INDEPENDENT
- Sets the relation between the number of coins and the number of credits.
- Sets the number of additional coins for the selection of the premium car (super car).
- Returns all the settings to the factory settings at time of shipment.

• The relationship between the number of coins and the number of credits

SETTING	1	2	3	4	5	6	7	8	9	10	11	12	13	14	15	16
COINS	1	1	1	1	1	1	1	2	2	2	3	3	3	4	4	4
CREDITS	1	2	3	4	5	6	7	1	3	5	1	2	4	1	3	5

SETTING	17	18	19	20	21	22	23	24	25	26	27	28	29	30	31	32
COINS	5	5	6	6	7	7	8	8	9	10	11	12	13	14	15	16
CREDITS	1	2	1	5	1	2	1	3	1	1	1	1	1	1	1	1

• The number of additional coins for the premium car

SETTING	1	2	3	4	5	6	7	8	9	10	11	12	13	14	15	16
COINS	1	2	3	4	5	6	7	8	9	10	11	12	13	14	15	16

• Networking Configuration

This mode automatically unifies the remaining machines in the network.

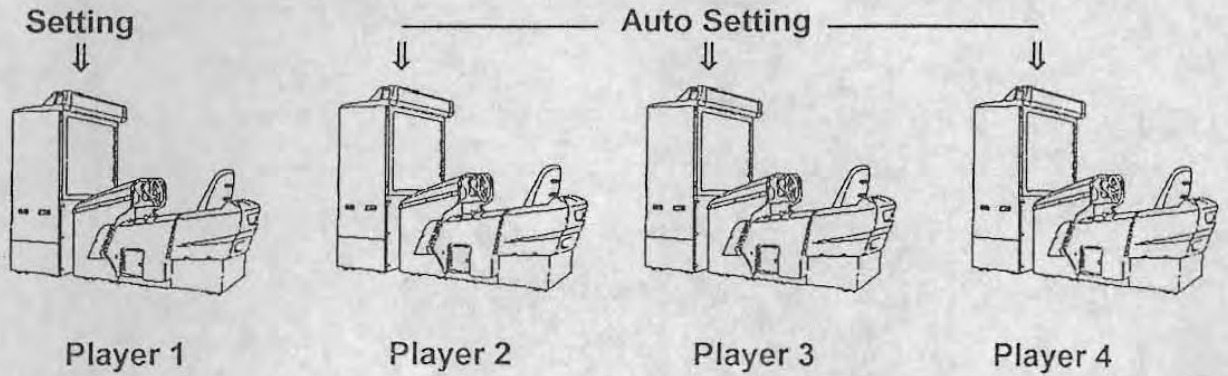

• Setting modes which can be unified are as follows:

- " SOUND OPTIONS " See page 23
- " GAME OPTIONS " See page 23
- " COIN OPTIONS " See page 24

• How to unify the settings

1. Since the machine modes are unified in network communication function, check whether the network communication is working correctly, using the " Network Check " mode.
2. All the machines which are connected to the network are displayed on the " Main Menu " screen for the manual test.
3. Set " Sound Options ", " Game Options " & " Coin Options " on just one of the machines in the network.
4. When the setting has finished, select the " Network Configuration " from the " Main Menu " screen, on the one machine that has just been set in action 3.
Push VIEW shift switch
5. Make sure that other machines connected to the network have entered into the " Network Configuration " mode.
6. The game is started automatically when the AT/MT shift switch is pushed. if the VIEW shift switch is pushed at this time, the screen returns to the " Main Menu "
7. When the network communication setting is over, the screen returns automatically to the " Main Menu ".

• If the network communication setting has not been made normally by the above steps 5 to 7, make the same setting by manually operating the individual machines.

3.6 Network abnormality counter measures.

If the " NETWORK ERROR " message appears, or if any item responds incorrectly in the network communication check described on pages 20 & 21, or the projector displays differ from the specified ones, take the following measures.



- If the same symptom persists in spite of taking measures or a problem not covered by this manual occurs, immediately turn off the power and do not operate the machine.

Symptom 1. The " NETWORK ERROR " message appears on the screen after the power is turned on.



Shows the " Network ID " of the game machine (1 to 4)

- Possible causes and measures to be taken

Possible causes	Measures
• The main DIP switch " Network ID " settings are improper	• Set DIP switches properly
• One of the networking cables has become disconnected from the machine	• Properly connect the network cables and make sure the pins are free from dirt & dust
• A network cable is connected between the pin jacks of the first and last machines	• Disconnect the network cable from those pin jacks

Symptom 2. The " NETWORK ERROR " message appears on the screen during playing

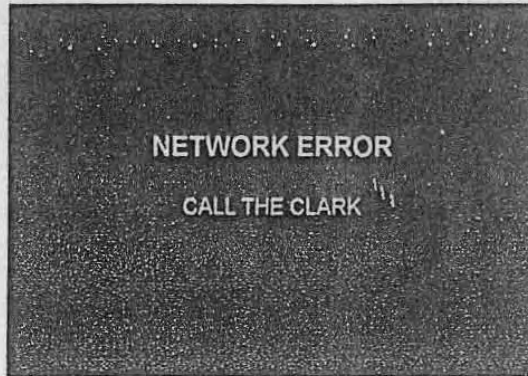

• Possible causes and measures to be taken

Possible causes	Measures
• One of the networking cords has been disconnected during play	• 1. Turn OFF the power 2. Re - connect the network cord 3. Turn ON the power
• One the networking cords has been damaged and could be broken internally	• Replace the networking cord with the spare network cord supplied.*
• The test switch (on the service panel) of one of the networked machines has been pushed	• 1. Turn OFF the power 2. Close the maintenance door 3. Turn ON the power
• Any of the machines which are connected through the network have different game option settings. (In manual test)	• Enter the manual test mode and set the same game options among all the machines.

* You can also use commercially sold video cable (75Ω 3C-FV) having a length of 2m or less.

4 Maintenance and annex

4.1 Replacing the coin acceptor



• Be sure to turn off the power switch and remove the power cord plug from the receptacle before replacing the coin selector.

1. Open the maintenance door.
2. Locate the coin acceptor as shown.

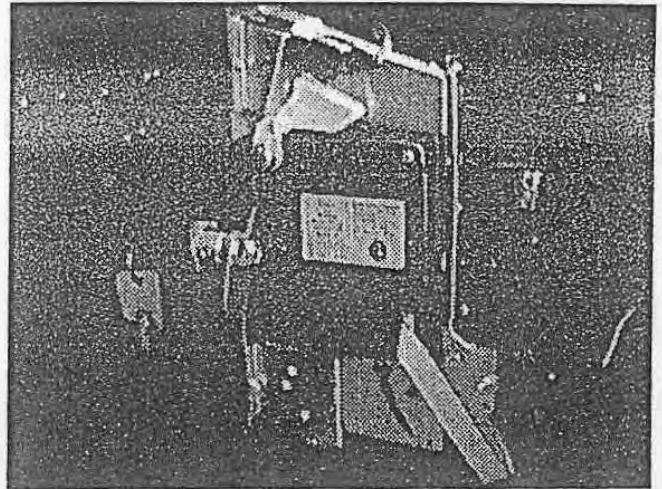

3. Remove the 10way IDC connector as illustrated. *Please take care to only apply force to the connector and not the grey ribbon cable.*

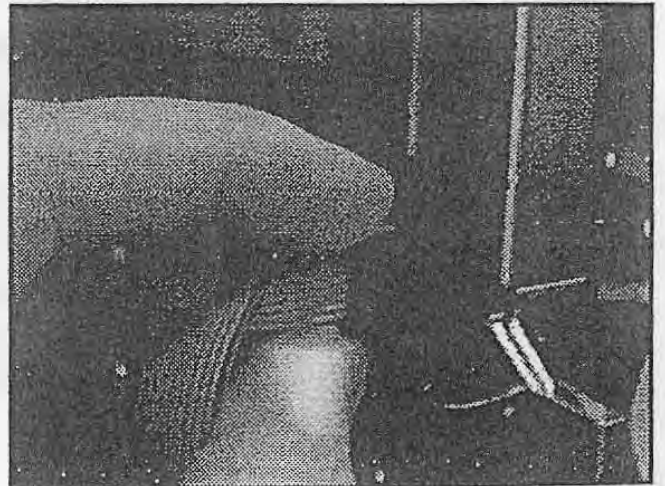

4.

Locate the retaining bar clip as shown
*This secures the retaining bar, holding the
acceptor into the coin bracket.*

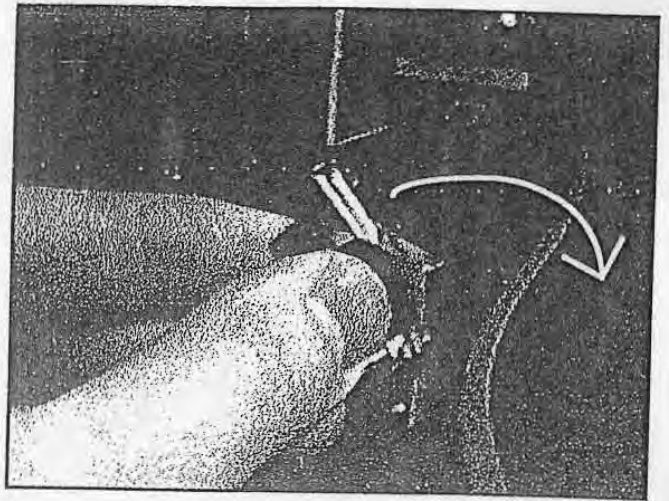

5.

Lift the clip 'clockwise' about its pivot.
This will release the retaining bar.

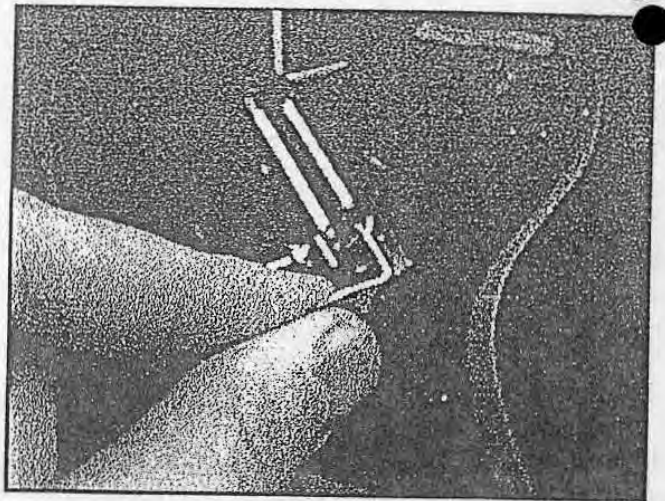

6.

Remove the retaining bar, freeing the
coin acceptor.

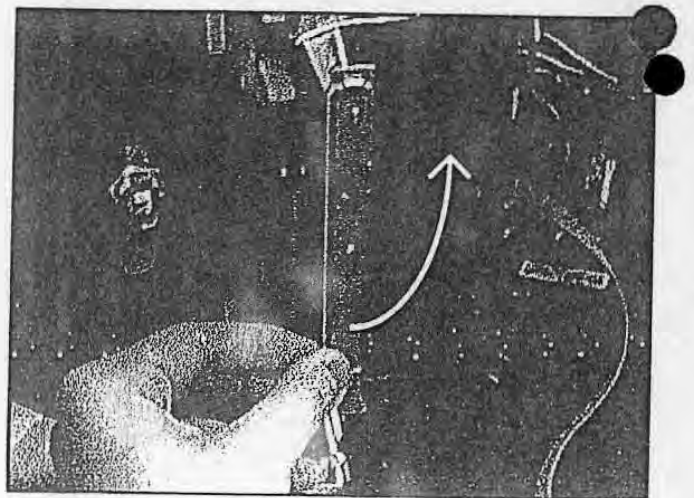

7.
Push the coin acceptor sideways to
release it from its holding bracket.
*Take care not to apply unnecessary force when
trying to free the acceptor.*

8.
Re-assemble with new acceptor in reverse
order.

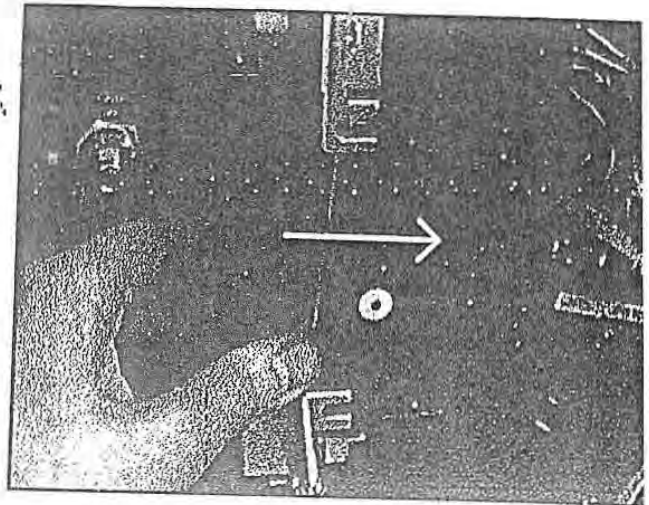

4.2 Replacing the fluorescent light



- Be sure to turn off the power switch and remove power cord before replacing the fluorescent light.
- The fluorescent light will be hot after use. Wait until it cools before replacing the unit with a newer one.
- Always exercise extreme caution when operating on mains wiring, ensure the power is disconnected before carrying out this procedure.

1. Remove the fixing screws from the underside of the light unit.

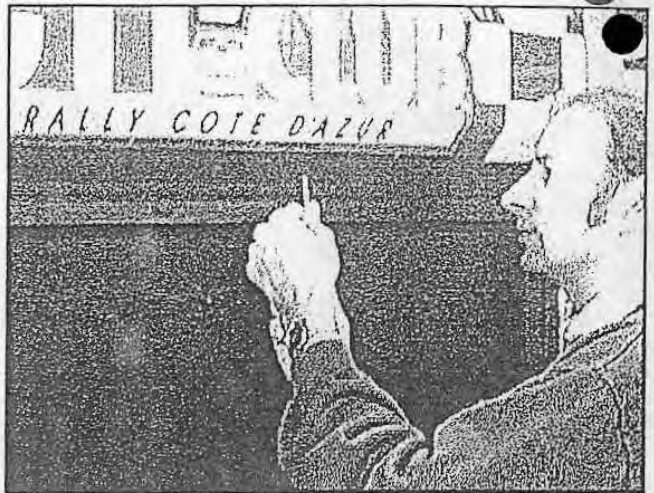

2. Slide the front perspex down, to gain access to the fluorescent tube.



3.

Remove the sockets on either end of the fluorescent tube by sliding them off. The tube can then be removed from the retaining clips.

If the starter needs replacing, replace it with one of a similar type.

Note the wattage rating printed on the side of the starter unit.

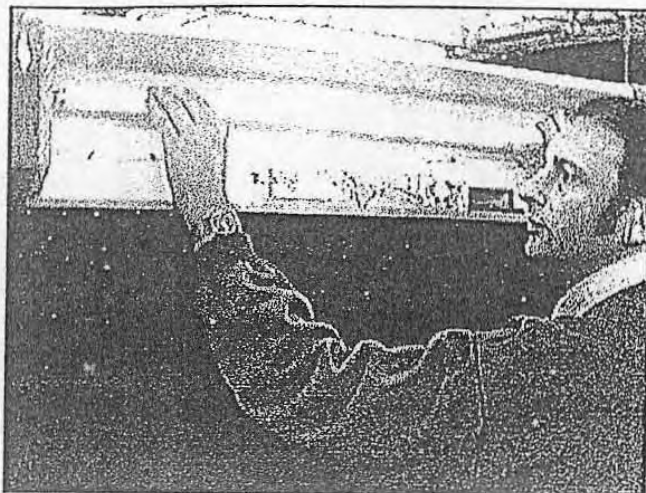

4.

Assembly is the reverse of the above procedure.

4.3 Replacing and adjusting the potentiometer

- How to replace the steering wheel unit potentiometer



- Be sure to turn OFF the power switch and remove the power cord plug from the receptacle before replacing the potentiometer

1.
Remove the top cover on the upper portion of the drive unit.

2.
Remove the cover of the steering wheel reaction force device.

Remove the two terminals connected to the VIEW shift switch and unplug the remaining loom.

Remove any cable ties that are securing the loom using a small pair of wire cutters. Take care not to damage the wiring.

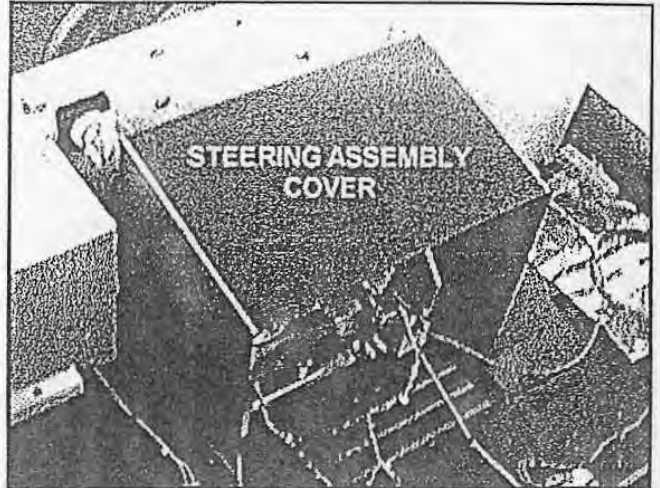

3.
Loosen the fixing screw on the shaft of the steering assembly. If this screw is not easily accessible, turn the steering wheel.

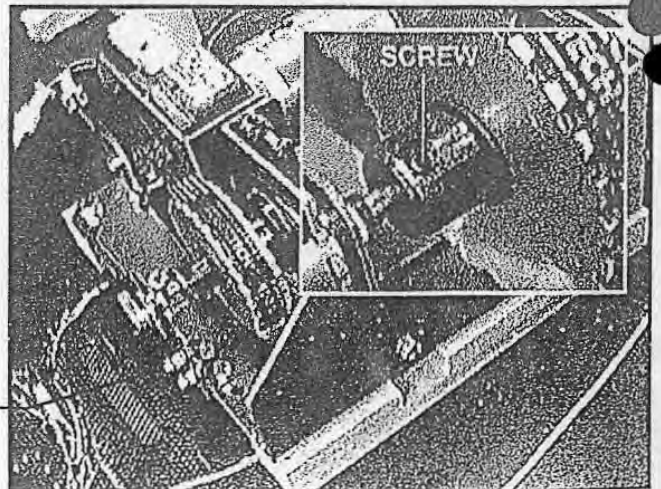

Remove the 2 screws holding the potentiometer bracket to the main assembly.

4. Remove the hexagon nut fastening the potentiometer to the bracket.

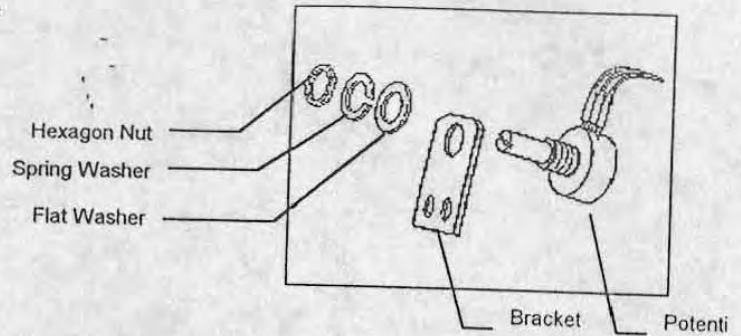

• How to adjust the steering wheel unit potentiometer

5. Attach a new potentiometer to the fixing bracket

6. De-solder the wiring from the faulty potentiometer and solder it to the replacement.
See page 49

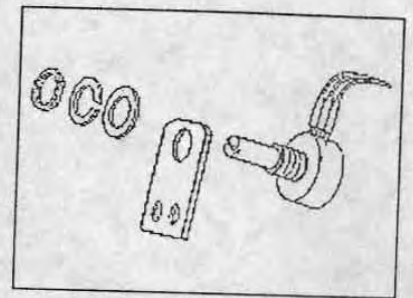

7. Check the wiring, before commencing further.

8. Using a flat blade screwdriver, adjust the potentiometer shaft as shown.

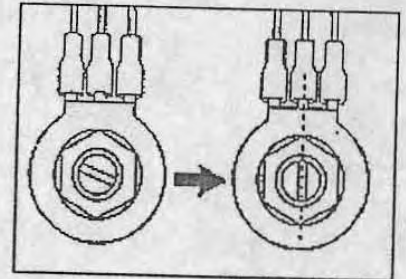

9. Mount the bracket on the main assembly using the 2 fixing screws.
Note: When the fixing screws are tightened up, it is normal that the bracket still has some play. It cannot be fixed tightly.

10. Reconnect the wiring to the VIEW shift switch

11. Reconnect the loom.

12. Tighten the grub screw on the steering shaft.

13. Carry out the test procedure as described in " 3.2 PCB Start up check (self test) " on page 15

• How to replace the pedal unit potentiometers



• Be sure to turn off the power switch and remove the power cord plug from the receptacle before replacing the potentiometers

1.
Remove the maintenance door from the front of the drive unit.

2.
Disconnect the pedal loom from the main loom.

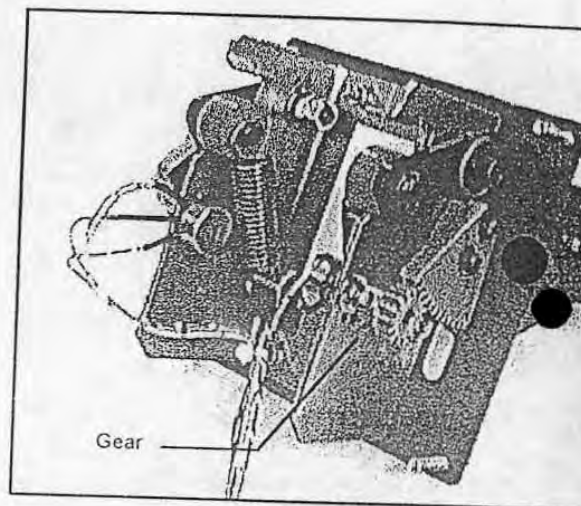

3.
Loosen the grub screws on the potentiometer shafts and remove both gears.

4.
Remove the hexagon nut fastening the potentiometer to the pedal assembly.

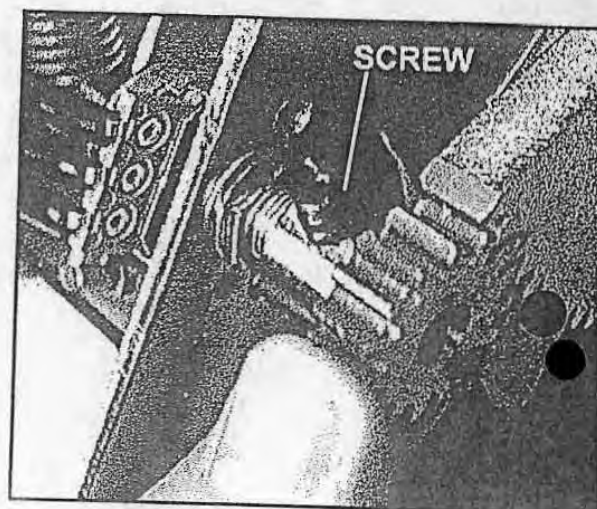

• How to adjust the pedal unit potentiometers

5.
Attach a new potentiometer to the pedal assembly.

6.
Desolder the loom from the faulty potentiometer and resolder it to the replacement.
See page 49

7.
Replace the gear on the potentiometer shaft, do not tighten the grub screw.

8.
Without moving the pedal, adjust the potentiometer with a flat blade screwdriver.

Adjustment Method

- Accelerator - Fully turn the potentiometer counter clockwise and then turn it back by about 10°
- Brake - Fully turn the potentiometer clockwise and then turn it back by about 10°

9.
When the potentiometers have been carefully adjusted, tighten the grub screws on the gear shaft.

10.
Make sure all fixings are secure and replace the maintenance door.

11.
Carry out the procedure described in "3.2 PCB Start-up check (self test) " on page 15

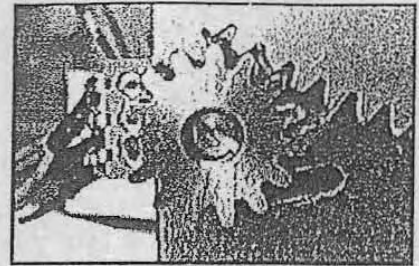

Figure 1 Brake Potentiometer setting



Figure 2 Accelerator potentiometer setting

• How to replace the hand brake potentiometer



- Be sure to turn OFF the power switch and pull out the power plug before replacing the control.
- Since the hand brake is heavy, use due care when handling it.

1.
Remove the rear moulding from the drive unit.



2.
Make sure you can gain access to the service plate mounted on the side of the handbrake unit.

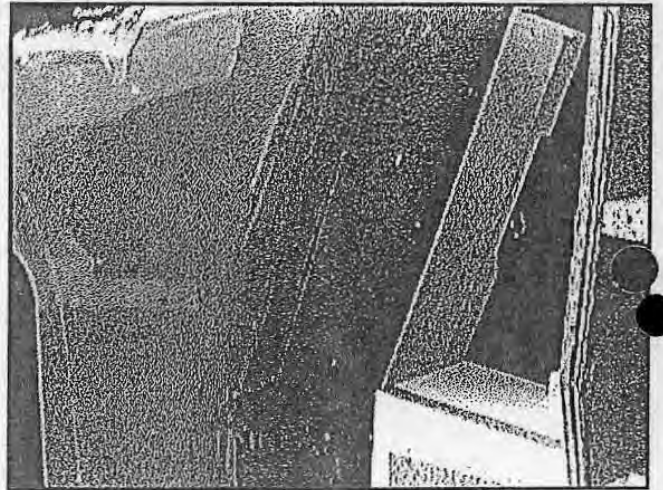

3.
Remove service plate to gain access to the potentiometer bracket.

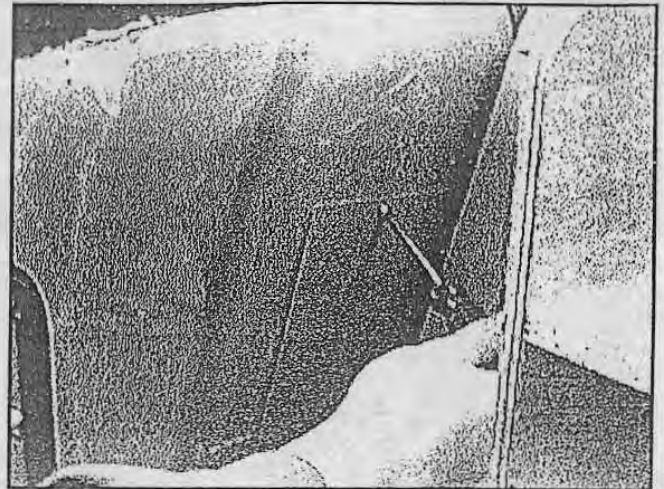

4.
Disconnect the loom connector, loosen the two screws holding the potentiometer bracket in place and slide the potentiometer bracket out.

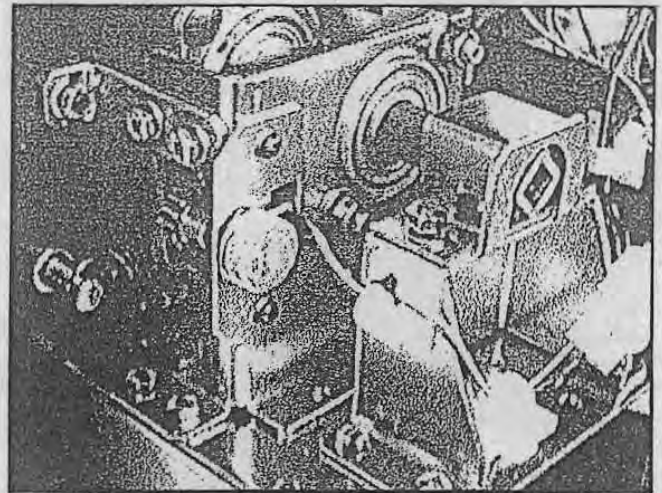

5.
Loosen the fixing screw and remove the gear.

6.
Remove the hexagon nut retaining the potentiometer to the bracket

7.
Replace faulty potentiometer.

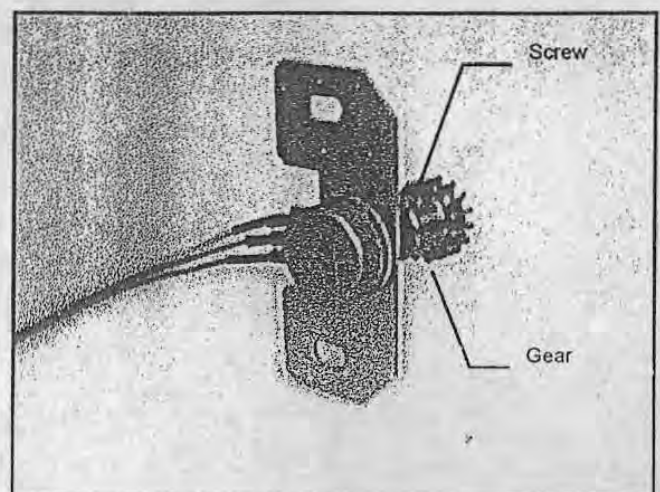

8.
Desolder the wiring from the faulty potentiometer and resolder it to the replacement.
See page 49

• How to adjust the handbrake potentiometer

9.
Replace gear on the shaft of the potentiometer and tighten grub screw.

10.
Align the groove in the shaft of the potentiometer as indicated.

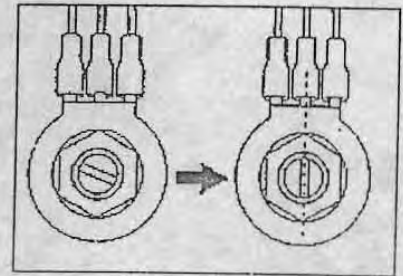

11.
Re-assemble the bracket onto the main handbrake assembly.

Mount the bracket so the gears engage each other, and move freely when the handbrake is moved. Replace lubricant if necessary. Use the following as a guide:

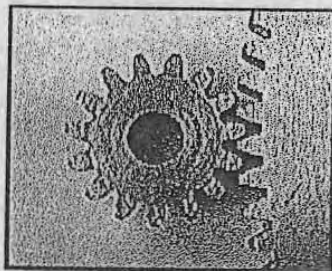

Figure 1 Too large clearance

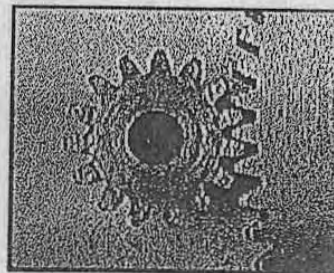

Figure 2 Correct clearance

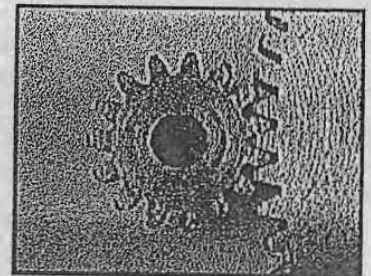

Figure 3 Too small clearance

12
When all the adjustments have been made, replace the service plate.

13
Re-assemble the handbrake unit to the drive unit.

14
Carry out the procedure described in " 3.2 PCB Start-up check (self test) " on page 15

4.4 Replacing the gear shift unit switch

- How to replace the gear shift unit microswitch



• Be sure to turn off the power switch and remove the power cord plug from the receptacle before replacing the potentiometers

1. Remove the 4 screws fastening the gear shift unit and take out the assembly.
2. Disconnect the loom connector from the main loom. Determine which is the faulty microswitch and remove it.
3. Desolder the wiring from the faulty microswitch and resolder it to the replacement.
4. When installing an new microswitch, take care to ensure the microswitch is positioned correctly.

Use the following as a guide:

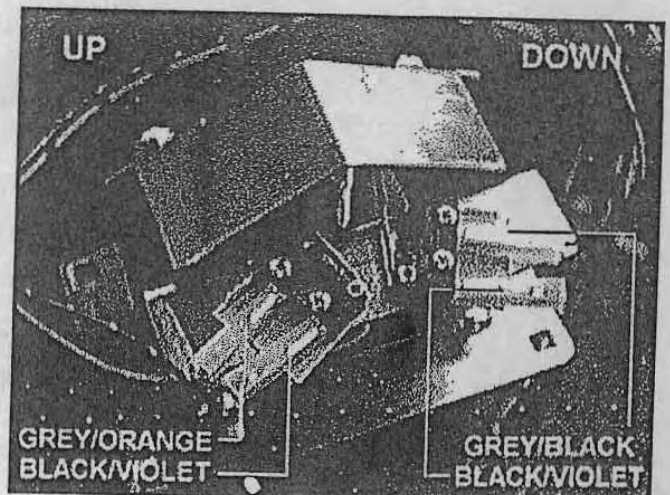

4.5 Replacing and adjusting the timing belt

- How to replace the timing belt



• Be sure to turn OFF the power switch and remove the power cord plug from the receptacle before replacing the potentiometers

1.
Remove the top cover from the drive unit.

2.
Remove the steering reaction device cover to gain access to the steering assembly.

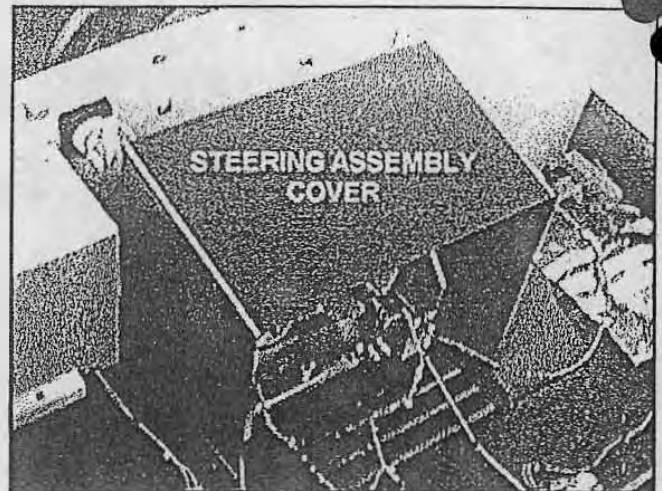

3.
Loosen the 3 motor bracket fixing screws and the adjuster bolt and remove the timing belt.

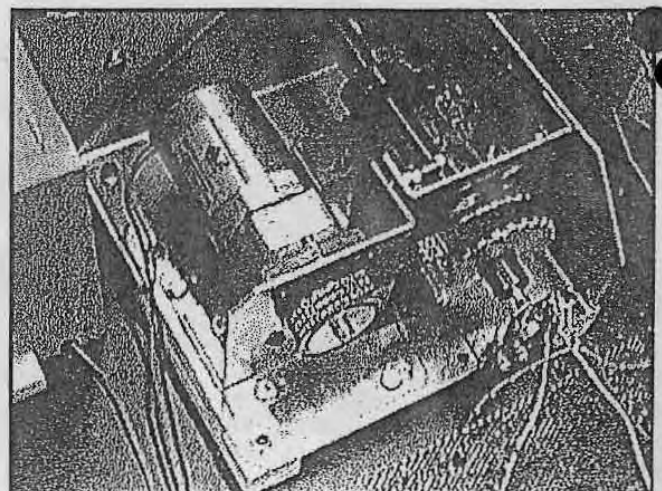

• How to adjust the timing belt

4. Loosen the 3 motor bracket fixing screws and adjust the timing belt tension by turning the adjuster bolt.

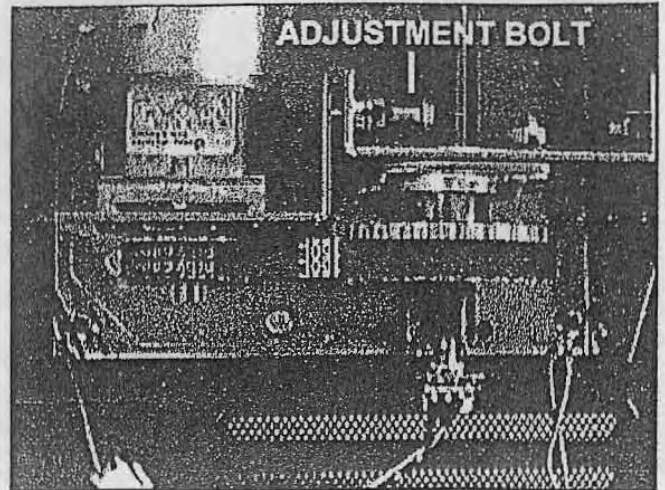

The sag of the belt should be 1.6mm for a weight 0.5Kg

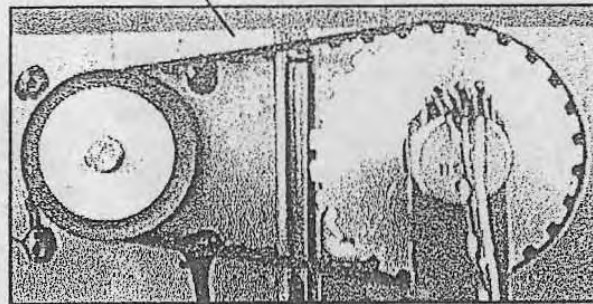

Figure 3 Timing belt sag

4.6 Adjusting the projector

- The projector has already been adjusted at the time of shipment, but it may be readjusted as desired.



- The interior of the projector contains high voltage electricity, so take great care not to touch it

• Projector Adjustment PCB

The projector adjustment PCB is located inside the projector maintenance door of the projector unit. (Loosen the 6 screws and remove panel)

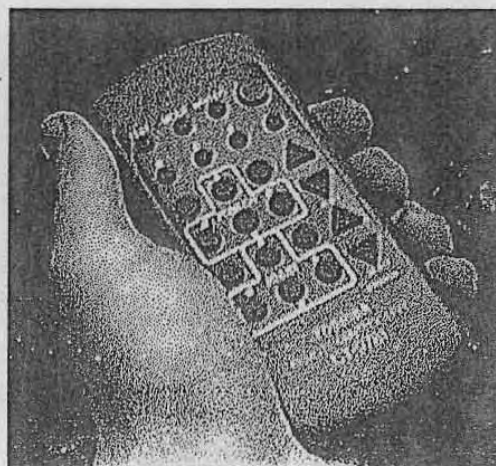
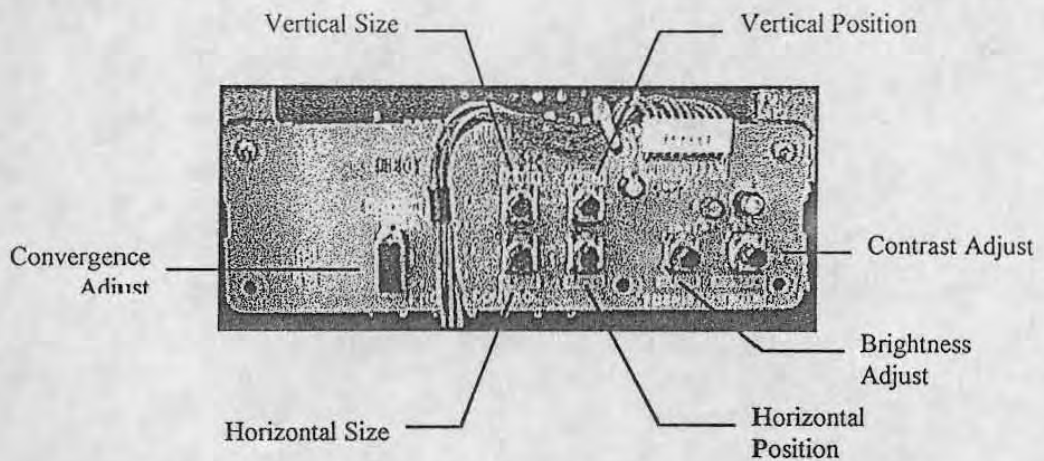

• How to adjust convergence



- Be sure to keep the **convergence adjust** switch off when not adjusting. After the completion of adjustment check that the **convergence adjust** switch is turned off.
- When using the remote control, keep it within a 30° angle to the top, bottom, left and right of the centre of the screen, standing no further than 3 metres.
- When the **reset** key is pushed during adjustment, the setting will revert to the original status before the adjustment was performed.
- When the screen is disturbed by static electricity etc. during the adjustment of the unit, turn off the power switch off and on, then readjust the unit.
- If the remote control does not work properly, replace the batteries with new ones. If the remote control is not to be used for a long time, remove the batteries from the remote control unit. Failure to do so could cause liquid leakage.

1.
Turn ON the Convergence adjust switch on the projector control PCB

2.
Point the remote control at the screen and push the TEST key for about 3 seconds
A green cross pattern should appear.

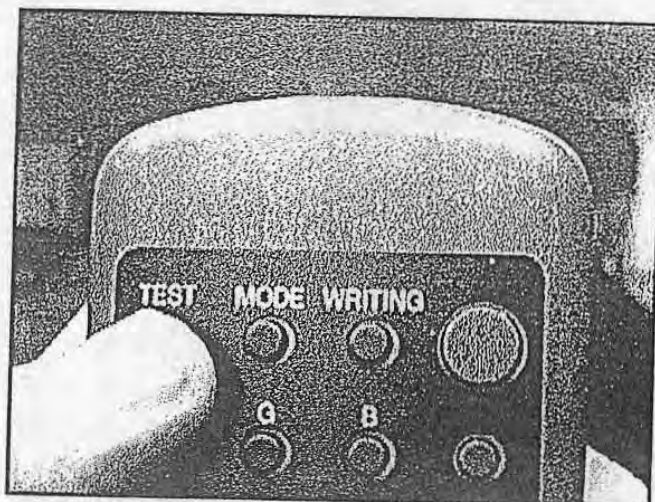

3.
When adjusting the red colour, push the R key on the remote control.
A red cross pattern appears on the screen along with the green cross pattern and the frame turns red.



4.
Using the ADJUST keys on the remote control, align the centre of the red cross with the centre of the green cross.
When the red cross is superimposed on the green cross, the resultant cross is yellow.

! Move the RED cross, not the green cross for adjustment !



5.
When adjusting the blue colour, push the B key on the remote control.
A blue cross pattern appears along with the yellow cross and the frame turns blue.

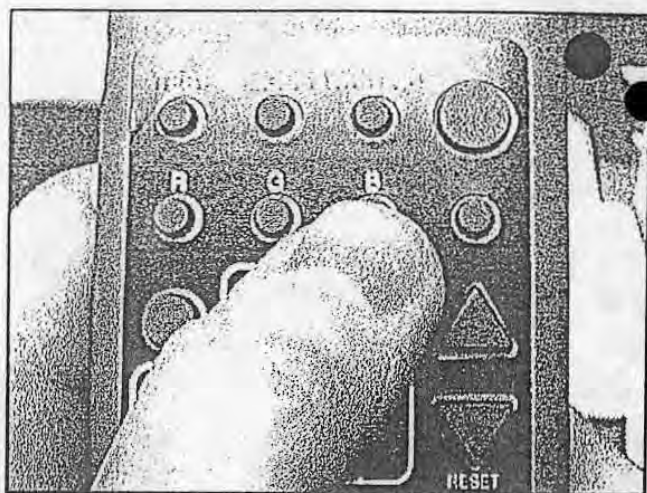

6.
Using the ADJUST keys on the remote control, align the centre of the blue cross with the centre of the yellow cross.
When the blue cross is superimposed on the yellow cross, the resultant cross is white.

• Selecting red again after adjusting blue will make the red disappear, so select a second time. Do the same when adjusting blue again after red.



7.
Push the WRITING key on the remote control to save the adjustments.

8.
Turn OFF the Convergence adjust switch on the projector control PCB



• If partial colour drift is found, perform the convergence adjustment in the following procedure:

- How to perform partial convergence adjustment



• Do not perform an extraordinary setting on purpose; otherwise it will cause damage.
• In case a problem happens during the adjustment, do not push the WRITING key but turn OFF the power switch and ON again, then readjust the unit.

1.
Turn ON the Convergence adjust switch on the projector control PCB.

2.
Point the remote control towards the screen and push the TEST key for about 3 seconds.
A green cross pattern should appear.

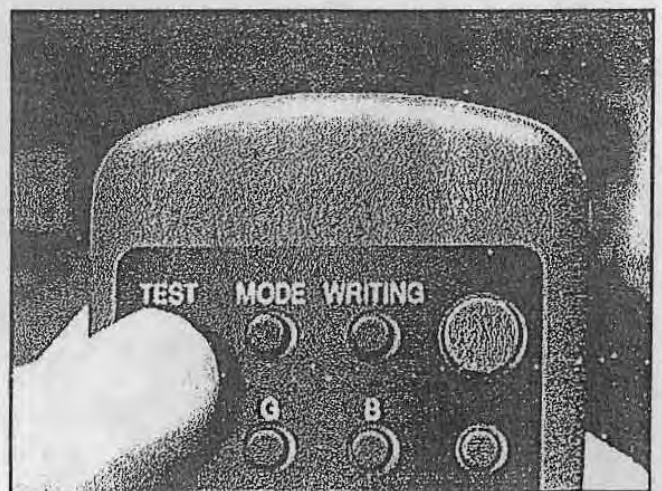

3.
Press the MODE key on the remote control.



Each press of the MODE key changes the mode in the following order:

adjustment \Rightarrow one-row adjustment \Rightarrow one-point adjustment

Select one of the modes according to the colour drift condition. Here we describe the procedure for carrying out partial convergence adjustment, assuring that the one-point adjustment mode has been selected: The screen shows a green checked test pattern and the marker indicating the place to be adjusted.

4.
When adjusting the red colour. Push the R key on the remote control
A red test pattern appears on screen along with the green test pattern and the green marker turns red.



5.
Use the POSITION keys on the remote control to move the marker to the place you want to adjust.
The range where the marker can move is limited.

6.
Use the ADJUST keys on the remote control to match the red test pattern to the green test pattern.
When the red test pattern is superimposed over the green one the resultant test pattern looks yellow.

7.
When adjusting the blue colour.
Push the B key on the remote control.

The blue test pattern is added to the screen and the red marker turns blue. Adjust the blue colour according to the procedure described in steps 5 & 6.

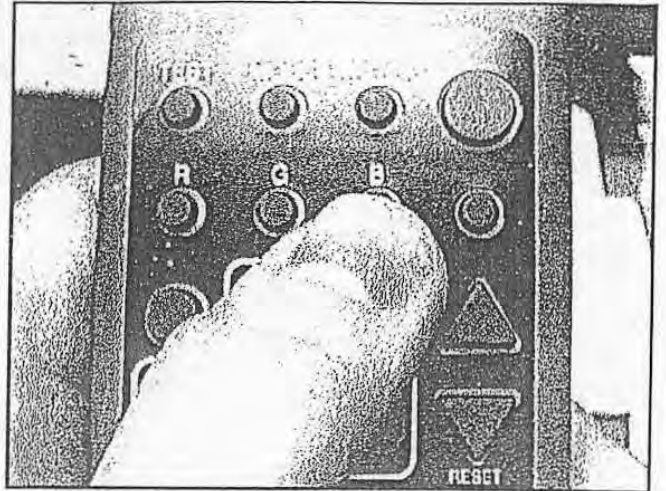

8.
Store the adjustment condition by pushing
the WRITING key on the remote control.

9.
Turn OFF the Convergence adjust switch on
the projector control PCB.

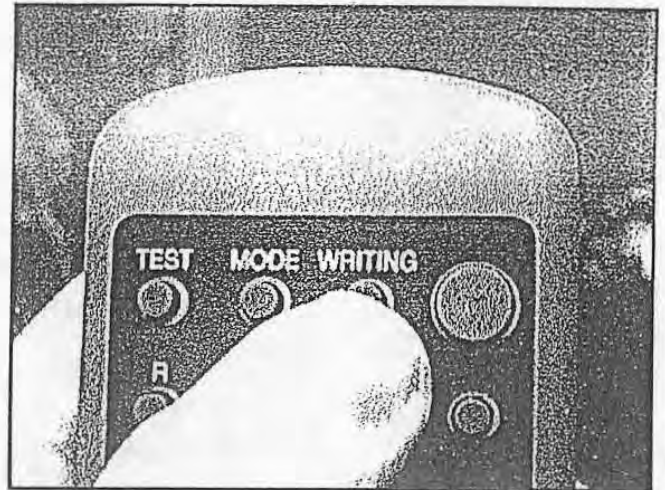

4.7 Potentiometer wiring information

When replacing the potentiometers in the game machine pay attention to the following colour codes used.



Potentiometer	1	2	3
Steering	BLACK / WHITE	RED / WHITE	PINK / WHITE
Accelerator	PINK / BLUE	RED / BLUE	BLACK / WHITE
Brake	BLACK / WHITE	RED / BLACK	PINK / BLUE
Hand Brake	PINK	BROWN	BLACK / YELLOW

When soldering the potentiometers the following points should be observed:

1. Excess heat can damage the potentiometer.
2. All wiring should be insulated using silicone sleeving or heatshrink tube.
3. Check all joints that have been made, they should appear shiny and have a good mechanical bond with both surfaces.
4. Poor soldering can cause intermittent faults with the controls, if in doubt leave any repairs to an appropriately skilled operative.

Appendix A - Coin settings

• The credit board settings need to be changed in accordance with the currency of each country.

Set dil switches (DIL 1) sw-1 to sw-5 according to the options found in the relevant price of play table on the following pages.

Set dil switches (DIL 2) sw-1 to sw-4, which are located under the IC socket as shown in the table below. Sw-4 must always be set to 'off' as the game board only operates in common mode. Care must be taken when removing the IC from its socket so as not to damage its leadout pins. After setting the switches replace the IC in its socket with the package ident mark adjacent to the board edge.



• Be sure to turn the power OFF before setting the DIP switches.

• The position of the coin selector DIP switches.

The coin selector DIP switches are provided inside the maintenance door. See page 10

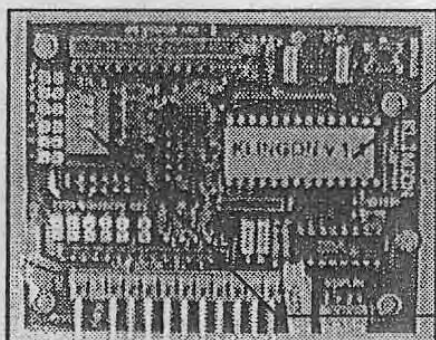

DIP Switch 1

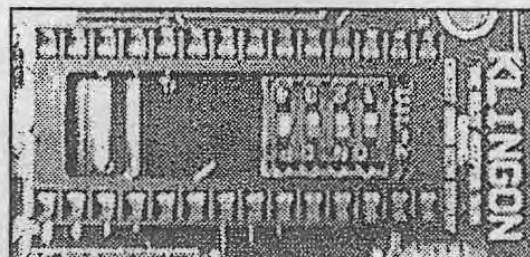

• Setting DIP switches 2

SW 1	SW 2	SW 3	SW 4	COIN SETTINGS	COIN 1	COIN 2	COIN 3	COIN 4
OFF	OFF	OFF	OFF	UK & GREECE	100	50	20	10
OFF	OFF	OFF	OFF	FINLAND & SWEDEN	10	5	2	1
ON	OFF	OFF	OFF	BELGIUM	N/U	50	20	N/U
OFF	ON	ON	OFF	FRANCE, AUSTRIA, NORWAY, DENMARK	20	10	5	1
OFF	OFF	ON	OFF	HOLLAND	N/U	5	2.5	1
OFF	ON	ON	OFF	PORTUGAL	200	100	50	N/U
ON	ON	ON	OFF	GERMANY & SWITZERLAND	5	2	1	N/U
ON	ON	ON	OFF	SOUTH AFRICA	5	2	1	N/U
ON	ON	ON	OFF	SPAIN & ITALY	500	200	100	N/U
				OFF	DIRECT MODE			
				ON	2 CHANNEL MODE			

• Setting DIP switches 1

Price of Play settings for the UK

			1	2	3	4	5
10p play	50p = 5	£1 = 10	OFF	OFF	OFF	OFF	OFF
10p play	50p = 5	£1 = 11	ON	OFF	OFF	OFF	OFF
10p play	50p = 6	£1 = 12	OFF	ON	OFF	OFF	OFF
20p play	50p = 2 1/2	£1 = 5	ON	ON	OFF	OFF	OFF
20p play	50p = 3	£1 = 6	OFF	OFF	ON	OFF	OFF
20p play	50p = 3	£1 = 7	ON	OFF	ON	OFF	OFF
30p play	50p = 1 2/3	£1 = 1 1/3	OFF	ON	ON	OFF	OFF
30p play	50p = 2	£1 = 4	ON	ON	ON	OFF	OFF
30p play	50p = 2	£1 = 5	OFF	OFF	OFF	ON	OFF
40p play	50p = 1 1/4	£1 = 2 1/2	ON	OFF	OFF	ON	OFF
40p play	50p = 1 1/4	£1 = 3	OFF	ON	OFF	ON	OFF
50p play	50p = 1	£1 = 2	ON	ON	OFF	ON	OFF
50p play	50p = 1	£1 = 3	OFF	OFF	ON	ON	OFF
60p play	50p = 5/6	£1 = 1 2/5	ON	OFF	ON	ON	OFF
60p play	50p = 5/6	£1 = 2	OFF	ON	ON	ON	OFF
80p play	50p = 5/8	£1 = 1 1/4	ON	ON	ON	ON	OFF
£1 play	50p = 1/2	£1 = 1	OFF	OFF	OFF	OFF	ON
£1 play	50p = 1/2	£1 = 1 £2 = 3	ON	OFF	OFF	OFF	ON
£2 play	50p = 1/4	£1 = 1/2	OFF	ON	OFF	OFF	ON
£2 play	50p = 1/4	£5 = 3	ON	ON	OFF	OFF	ON
£3 play	NO BONUSSES		OFF	OFF	ON	OFF	ON
£3 play		£5 = 3	ON	OFF	ON	OFF	ON
£5 play	NO BONUSSES		OFF	ON	ON	OFF	ON
£5 play		£10 = 3	ON	ON	ON	OFF	ON
FREE PLAY OPTION			ON	ON	ON	ON	ON

Price of Play settings for GREECE

			1	2	3	4	5
10 play	50 = 5	100 = 10	OFF	OFF	OFF	OFF	OFF
10 play	50 = 5	100 = 11	ON	OFF	OFF	OFF	OFF
10 play	50 = 6	100 = 12	OFF	ON	OFF	OFF	OFF
20 play	50 = 2 1/2	100 = 5	ON	ON	OFF	OFF	OFF
20 play	50 = 3	100 = 6	OFF	OFF	ON	OFF	OFF
20 play	50 = 3	100 = 7	ON	OFF	ON	OFF	OFF
30 play	50 = 1 2/3	100 = 1 1/3	OFF	ON	ON	OFF	OFF
30 play	50 = 2	100 = 4	ON	ON	ON	OFF	OFF
30 play	50 = 2	100 = 5	OFF	OFF	OFF	ON	OFF
40 play	50 = 1 1/4	100 = 2 1/2	ON	OFF	OFF	ON	OFF
40 play	50 = 1 1/4	100 = 3	OFF	ON	OFF	ON	OFF
50 play	50 = 1	100 = 2	ON	ON	OFF	ON	OFF
50 play	50 = 1	100 = 3	OFF	OFF	ON	ON	OFF
60 play	50 = 5/6	100 = 1 2/5	ON	OFF	ON	ON	OFF
60 play	50 = 5/6	100 = 2	OFF	ON	ON	ON	OFF
80 play	50 = 5/8	100 = 1 1/4	ON	ON	ON	ON	OFF
100 play	50 = 1/2	100 = 1	OFF	OFF	OFF	OFF	ON
100 play	50 = 1/2	100 = 1 200 = 3	ON	OFF	OFF	OFF	ON
200 play	50 = 1/4	100 = 1/2	OFF	ON	OFF	OFF	ON
200 play	50 = 1/4	100 = 1/2 500 = 3	ON	ON	OFF	OFF	ON
300 play	NO BONUSSES		OFF	OFF	ON	OFF	ON
300 play		500 = 3	ON	OFF	ON	OFF	ON
500 play	NO BONUSSES		OFF	ON	ON	OFF	ON
500 play		1000 = 3	ON	ON	ON	OFF	ON
FREE PLAY OPTION			ON	ON	ON	ON	ON

Price of Play settings for BELGIUM

			1	2	3	4	5
5F play	20F = 4	50F = 10	OFF	OFF	OFF	OFF	OFF
5F play	20F =	50F = 11	ON	OFF	OFF	OFF	OFF
5F play	20F = 5	50F = 12	OFF	ON	OFF	OFF	OFF
10F play	20F = 2	50F = 5	ON	ON	OFF	OFF	OFF
10F play	20F = 2	50F = 5	OFF	OFF	ON	OFF	OFF
10F play	20F = 3	50F = 7	ON	OFF	ON	OFF	OFF
15F play	20F = 1 1/3	50F = 3 1/3	OFF	ON	ON	OFF	OFF
15F play	20F = 1 1/3	50F = 4	ON	ON	ON	OFF	OFF
15F play	20F = 2	50F = 5	OFF	OFF	OFF	ON	OFF
20F play		50F = 2 1/2	ON	OFF	OFF	ON	OFF
20F play		50F = 3	OFF	ON	OFF	ON	OFF
20F play	50F = 3	100F = 7	ON	ON	OFF	ON	OFF
25F play	20F = 4/5	50F = 2	OFF	OFF	ON	ON	OFF
25F play	20F = 4/5	50F = 2 100F = 5	ON	OFF	ON	ON	OFF
25F play	20F = 4/5	50F = 3 100F = 6	OFF	ON	ON	ON	OFF
30F play	20F = 2/3	50F = 1 1/2	ON	ON	ON	ON	OFF
30F play	20F = 2/3	50F = 1 1/3 100F = 4	OFF	OFF	OFF	OFF	ON
30F play	20F = 2/3	50F = 2 100F = 4	ON	OFF	OFF	OFF	ON
40F play	20F = 1/2	50F = 1 1/4	OFF	ON	OFF	OFF	ON
40F play	20F = 1/2	50F = 2 1/4	ON	ON	OFF	OFF	ON
50F play	NO BONUSSES		OFF	OFF	ON	OFF	ON
50F play		100F = 3	ON	OFF	ON	OFF	ON
50F play		100F = 3	OFF	ON	ON	OFF	ON
FREE PLAY OPTION			ON	ON	ON	ON	ON

Price of Play settings for SPAIN / ITALY

			1	2	3	4	5
100 play	500 = 5	1000 = 10	OFF	OFF	OFF	OFF	OFF
100 play	500 = 5	1000 = 11	ON	OFF	OFF	OFF	OFF
100 play	500 = 6	1000 = 12	OFF	ON	OFF	OFF	OFF
200 play	500 = 2 1/2	1000 = 5	ON	ON	OFF	OFF	OFF
200 play	500 = 3	1000 = 6	OFF	OFF	ON	OFF	OFF
200 play	500 = 3	1000 = 7	ON	OFF	ON	OFF	OFF
300 play	500 = 1 2/3	1000 = 1 1/3	OFF	ON	ON	OFF	OFF
300 play	500 = 2	1000 = 4	ON	ON	ON	OFF	OFF
300 play	500 = 2	1000 = 5	OFF	OFF	OFF	ON	OFF
400 play	500 = 1 1/4	1000 = 2 1/2	ON	OFF	OFF	ON	OFF
400 play	500 = 1 1/4	1000 = 3	OFF	ON	OFF	ON	OFF
500 play	500 = 1	1000 = 2	ON	ON	OFF	ON	OFF
500 play	500 = 1	1000 = 3	OFF	OFF	ON	ON	OFF
600 play	500 = 5/6	1000 = 1 2/5	ON	OFF	ON	ON	OFF
600 play	500 = 5/6	1000 = 2	OFF	ON	ON	ON	OFF
800 play	500 = 5/8	1000 = 1 1/4	ON	ON	ON	ON	OFF
1000 play	500 = 1/2	1000 = 1	OFF	OFF	OFF	OFF	ON
1000 play	500 = 1/2	1000 = 1 2000 = 3	ON	OFF	OFF	OFF	ON
2000 play	500 = 1/4	1000 = 1/2	OFF	ON	OFF	OFF	ON
2000 play	500 = 1/4	1000 = 1/2 5000 = 3	ON	ON	OFF	OFF	ON
3000 play	NO BONUSSES		OFF	OFF	ON	OFF	ON
3000 play		5000 = 3	ON	OFF	ON	OFF	ON
5000 play	NO BONUSSES		OFF	ON	ON	OFF	ON
5000 play		10,000 = 3	ON	ON	ON	OFF	ON
FREE PLAY OPTION			ON	ON	ON	ON	ON

Price of Play settings for DENMARK, SWEDEN, NORWAY & FINLAND

			1	2	3	4	5
1 Kr play	5 Kr = 5 CR	10 Kr = 10 CR	OFF	OFF	OFF	OFF	OFF
1 Kr play	5 Kr = 5 CR	10 Kr = 11 CR	ON	OFF	OFF	OFF	OFF
1 Kr play	5 Kr = 6 CR	10 Kr = 12 CR	OFF	ON	OFF	OFF	OFF
2 Kr play	5 Kr = 2.5 CR	10 Kr = 5 CR	ON	ON	OFF	OFF	OFF
2 Kr play	5 Kr = 3 CR	10 Kr = 6 CR	OFF	OFF	ON	OFF	OFF
2 Kr play	5 Kr = 3 CR	10 Kr = 7 CR	ON	OFF	ON	OFF	OFF
3 Kr play	5 Kr = 1.6 CR	10 Kr = 3.3 CR	OFF	ON	ON	OFF	OFF
3 Kr play	5 Kr = 2 CR	10 Kr = 4 CR	ON	ON	ON	OFF	OFF
3 Kr play	5 Kr = 2 CR	10 Kr = 5CR	OFF	OFF	OFF	ON	OFF
4 Kr play	5 Kr = 1.25 CR	10 Kr = 2.5 CR	ON	OFF	OFF	ON	OFF
4 Kr play	5 Kr = 1.25 CR	10 Kr = 3 CR	OFF	ON	OFF	ON	OFF
5 Kr play	5 Kr = 1 CR	10 Kr = 2 CR	ON	ON	OFF	ON	OFF
5 Kr play	5 Kr = 1 CR	10 Kr = 3 CR	OFF	OFF	ON	ON	OFF
6 Kr play	5 Kr = 0.83 CR	10 Kr = 1.25CR	ON	OFF	ON	ON	OFF
6 Kr play	5 Kr = 0.83 CR	10 Kr = 2 CR	OFF	ON	ON	ON	OFF
8 Kr play	5 Kr = 0.62 CR	10 Kr = 1.25CR	ON	ON	ON	ON	OFF
10 Kr play	5 Kr = 0.5 CR	10 Kr = 1CR	OFF	OFF	OFF	OFF	ON
10 Kr play	5 Kr = 0.5 CR	20 Kr = 2	ON	OFF	OFF	OFF	ON
20 Kr play	5 Kr = 0.25 CR	10 Kr = 0.5 CR	OFF	ON	OFF	OFF	ON
20 Kr play	5 Kr = 0.25 CR	10 Kr = 0.5 CR 50 Kr = 3 CR	ON	ON	OFF	OFF	ON
30 Kr play	NO BONUSES						
30 Kr play		50 Kr = 3 CR					
50 Kr play	NO BONUSES						
50 Kr play		100 Kr = 3 CR					
FREE PLAY OPTION			ON	ON	ON	ON	ON

METER OPERATES ON 1Kr = 1 PULSE

FINLAND / SWEDEN COINAGE : COIN 1 = 10Kr, COIN 2 = 5Kr, COIN 3 = 2Kr, COIN 4 = 1Kr

DENMARK / NORWAY COINAGE : COIN 1 = 20Kr, COIN 2 = 10Kr, COIN 3 = 5Kr, COIN 4 = 1Kr

Price of Play settings for GERMANY

			1	2	3	4	5
1 DM play	5 DM = 5 CR	10 DM = 10 CR	OFF	OFF	OFF	OFF	OFF
1 DM play	5 DM = 5 CR	10 DM = 11 CR	ON	OFF	OFF	OFF	OFF
1 DM play	5 DM = 6 CR	10 DM = 12 CR	OFF	ON	OFF	OFF	OFF
2 DM play	5 DM = 2.5 CR	10 DM = 5 CR	ON	ON	OFF	OFF	OFF
2 DM play	5 DM = 3 CR	10 DM = 6 CR	OFF	OFF	ON	OFF	OFF
2 DM play	5 DM = 3 CR	10 DM = 7 CR	ON	OFF	ON	OFF	OFF
3 DM play	5 DM = 1.6 CR	10 DM = 3.3 CR	OFF	ON	ON	OFF	OFF
3 DM play	5 DM = 2 CR	10 DM = 4 CR	ON	ON	ON	OFF	OFF
3 DM play	5 DM = 2 CR	10 DM = 5CR	OFF	OFF	OFF	ON	OFF
4 DM play	5 DM = 1.25 CR	10 DM = 2.5 CR	ON	OFF	OFF	ON	OFF
4 DM play	5 DM = 1.25 CR	10 DM = 3 CR	OFF	ON	OFF	ON	OFF
5 DM play	5 DM = 1 CR	10 DM = 2 CR	ON	ON	OFF	ON	OFF
5 DM play	5 DM = 1 CR	10 DM = 3 CR	OFF	OFF	ON	ON	OFF
6 DM play	5 DM = 0.83 CR	10 DM = 1.25CR	ON	OFF	ON	ON	OFF
6 DM play	5 DM = 0.83 CR	10 DM = 2 CR	OFF	ON	ON	ON	OFF
8 DM play	5 DM = 0.62 CR	10 DM = 1.25CR	ON	ON	ON	ON	OFF
10 DM play	5 DM = 0.5 CR	10 DM = 1CR	OFF	OFF	OFF	OFF	ON
10 DM play	5 DM = 0.5 CR	20 DM = 2	ON	OFF	OFF	OFF	ON
20 DM play	5 DM = 0.25 CR	10 DM = 0.5 CR	OFF	ON	OFF	OFF	ON
20 DM play	5 DM = 0.25 CR	10 DM = 0.5 CR 50 DM = 3 CR	ON	ON	OFF	OFF	ON
30 DM play	NO BONUSES		OFF	OFF	ON	OFF	ON
30 DM play		50 DM = 3 CR	ON	OFF	ON	OFF	ON
50 DM play	NO BONUSES		OFF	ON	ON	OFF	ON
50 DM play		100 DM = 3 CR	ON	ON	ON	OFF	ON
FREE PLAY OPTION			ON	ON	ON	ON	ON

Price of Play settings for HOLLAND

			1	2	3	4	5
1G play	NO BONUS		OFF	OFF	OFF	OFF	OFF
1G play	2.5G = 3	5G = 6	ON	OFF	OFF	OFF	OFF
1G play	2.5G = 3	5G = 7	OFF	ON	OFF	OFF	OFF
2G play	NO BONUS	50F = 5	ON	ON	OFF	OFF	OFF
2G play	5G = 3		OFF	OFF	ON	OFF	OFF
2G play	5G = 3	10G = 7	ON	OFF	ON	OFF	OFF
3G play	NO BONUS		OFF	ON	ON	OFF	OFF
3G play	5G = 2		ON	ON	ON	OFF	OFF
3G play	5G = 2	10G = 5	OFF	OFF	OFF	ON	OFF
4G play	NO BONUS		ON	OFF	OFF	ON	OFF
4G play	10G = 3		OFF	ON	OFF	ON	OFF
5G play	NO BONUS	100F = 7	ON	ON	OFF	ON	OFF
5G play	10G = 3		OFF	OFF	ON	ON	OFF
6G play	NO BONUS		ON	OFF	ON	ON	OFF
6G play	15G = 3	50F = 3 100F = 6	OFF	ON	ON	ON	OFF
8G play	NO BONUS		ON	ON	ON	ON	OFF
8G play	20G = 3	50F = 1 1/3 100F = 4	OFF	OFF	OFF	OFF	ON
10G play	NO BONUS		ON	OFF	OFF	OFF	ON
10G play	20G = 3		OFF	ON	OFF	OFF	ON
			ON	ON	OFF	OFF	ON
FREE PLAY OPTION			ON	ON	ON	ON	ON

1 METER PULSE = 0.5G COIN 1=N/U, COIN 2=5G, COIN 3=2.5G, COIN 4=1G

Price of Play settings for PORTUGAL

			1	2	3	4	5
10 Esc play	50 Esc = 5	100 Esc = 10	OFF	OFF	OFF	OFF	OFF
10 Esc play	50 Esc = 5	100 Esc = 11	ON	OFF	OFF	OFF	OFF
10 Esc play	50 Esc = 6	100 Esc = 12	OFF	ON	OFF	OFF	OFF
20 Esc play	50 Esc = 2 1/2	100 Esc = 5	ON	ON	OFF	OFF	OFF
20 Esc play	50 Esc = 3	100 Esc = 6	OFF	OFF	ON	OFF	OFF
20 Esc play	50 Esc = 3	100 Esc = 7	ON	OFF	ON	OFF	OFF
30 Esc play	50 Esc = 1 2/3	100 Esc = 1 1/3	OFF	ON	ON	OFF	OFF
30 Esc play	50 Esc = 2	100 Esc = 4	ON	ON	ON	OFF	OFF
30 Esc play	50 Esc = 2	100 Esc = 5	OFF	OFF	OFF	ON	OFF
40 Esc play	50 Esc = 1 1/4	100 Esc = 2 1/2	ON	OFF	OFF	ON	OFF
40 Esc play	50 Esc = 1 1/4	100 Esc = 3	OFF	ON	OFF	ON	OFF
50 Esc play	50 Esc = 1	100 Esc = 2	ON	ON	OFF	ON	OFF
50 Esc play	50 Esc = 1	100 Esc = 3	OFF	OFF	ON	ON	OFF
60 Esc play	50 Esc = 5/6	100 Esc = 1 2/5	ON	OFF	ON	ON	OFF
60 Esc play	50 Esc = 5/6	100 Esc = 2	OFF	ON	ON	ON	OFF
80 Esc play	50 Esc = 5/8	100 Esc = 1 1/4	ON	ON	ON	ON	OFF
100 Esc play	50 Esc = 1/2	100 Esc = 1	OFF	OFF	OFF	OFF	ON
100 Esc play	50 Esc = 1/2	100 Esc = 1 200 Esc = 3	ON	OFF	OFF	OFF	ON
200 Esc play	50 Esc = 1/4	100 Esc = 1/2	OFF	ON	OFF	OFF	ON
200 Esc play	50 esc = 1/4	100 Esc = 1/2 500 Esc = 3	ON	ON	OFF	OFF	ON
300 Esc play	NO BONUSSES		OFF	OFF	ON	OFF	ON
300 Esc play		500 Esc = 3	ON	OFF	ON	OFF	ON
500 Esc play	NO BONUSSES		OFF	ON	ON	OFF	ON
500 Esc play		1000 Esc = 3	ON	ON	ON	OFF	ON
FREE PLAY OPTION			ON	ON	ON	ON	ON

Price of Play settings for AÜSTRIA

			1	2	3	4	5
1 Sch	5 Sch = 5	10 Sch = 10	OFF	OFF	OFF	OFF	OFF
1 Sch	5 Sch = 5	10 Sch = 11	ON	OFF	OFF	OFF	OFF
1 Sch	5 Sch = 6	10 Sch = 12	OFF	ON	OFF	OFF	OFF
2 Sch	5 Sch = 2 1/2	10 Sch = 5	ON	ON	OFF	OFF	OFF
2 Sch	5 Sch = 3	10 Sch = 6	OFF	OFF	ON	OFF	OFF
2 Sch	5 Sch = 3	10 Sch = 7	ON	OFF	ON	OFF	OFF
3 Sch	5 Sch = 1 2/3	10 Sch = 3 1/3	OFF	ON	ON	OFF	OFF
3 Sch	5 Sch = 2	10 Sch = 4	ON	ON	ON	OFF	OFF
3 Sch	5 Sch = 2	10 Sch = 5	OFF	OFF	OFF	ON	OFF
4 Sch	5 Sch = 1 1/4	10 Sch = 2 1/2	ON	OFF	OFF	ON	OFF
4 Sch	5 Sch = 1 1/4	10 Sch = 3	OFF	ON	OFF	ON	OFF
5 Sch	5 Sch = 1	10 Sch = 2	ON	ON	OFF	ON	OFF
5 Sch	5 Sch = 1	10 Sch = 3	OFF	OFF	ON	ON	OFF
6 Sch	5 Sch = 5/6	10 Sch = 1 2/5	ON	OFF	ON	ON	OFF
6 Sch	5 Sch = 5/6	10 Sch = 2	OFF	ON	ON	ON	OFF
8 Sch	5 Sch = 5/8	10 Sch = 1 1/4	ON	ON	ON	ON	OFF
10 Sch	5 Sch = 1/2	10 Sch = 1	OFF	OFF	OFF	OFF	ON
10 Sch	5 Sch = 1/2	10 Sch = 1 20 Sch = 3	ON	OFF	OFF	OFF	ON
20 Sch	5 Sch = 1/4	10 Sch = 1/2	OFF	ON	OFF	OFF	ON
20 Sch	5 Sch = 1/4	10 Sch = 1/2 50 Sch = 3	ON	ON	OFF	OFF	ON
30 Sch	NO BONUSSES		OFF	OFF	ON	OFF	ON
30 Sch	5 Sch = 3		ON	OFF	ON	OFF	ON
50 Sch	NO BONUSSES		OFF	ON	ON	OFF	ON
50 Sch		100 Sch = 3	ON	ON	ON	OFF	ON
FREE PLAY OPTION			ON	ON	ON	ON	ON

COIN 1 = 20 Sch, COIN 2 = 10 Sch, COIN 3 = 5 Sch, COIN 4 = 1 Sch

Price of Play settings for FRANCE / SWITZERLAND

			1	2	3	4	5
1F play	5F = 5	10F = 10	OFF	OFF	OFF	OFF	OFF
1F play	5F = 5	10F = 11	ON	OFF	OFF	OFF	OFF
1F play	5F = 6	10F = 12	OFF	ON	OFF	OFF	OFF
2F play	5F = 2 1/2	10F = 5	ON	ON	OFF	OFF	OFF
2F play	5F = 3	10F = 6	OFF	OFF	ON	OFF	OFF
2F play	5F = 3	10F = 7	ON	OFF	ON	OFF	OFF
3F play	5F = 1 2/3	10F = 3 1/3	OFF	ON	ON	OFF	OFF
3F play	5F = 2	10F = 4	ON	ON	ON	OFF	OFF
3F play	5F = 2	10F = 5	OFF	OFF	OFF	ON	OFF
4F play	5F = 1 1/4	10F = 2 1/2	ON	OFF	OFF	ON	OFF
4F play	5F = 1 1/4	10F = 3	OFF	ON	OFF	ON	OFF
5F play	5F = 1	10F = 2	ON	ON	OFF	ON	OFF
5F play	5F = 1	10F = 3	OFF	OFF	ON	ON	OFF
6F play	5F = 5/6	10F = 1 2/5	ON	OFF	ON	ON	OFF
6F play	5F = 5/6	10F = 2	OFF	ON	ON	ON	OFF
8F play	5F = 5/8	10F = 1 1/4	ON	ON	ON	ON	OFF
10F play	5F = 1/2	10F = 1	OFF	OFF	OFF	OFF	ON
10F play	5F = 1/2	10F = 1 20F=3	ON	OFF	OFF	OFF	ON
20F play	5F = 1/4	10F = 1/2	OFF	ON	OFF	OFF	ON
20F play	5F = 1/4	10F = 1/2 50F=3	ON	ON	OFF	OFF	ON
FREE PLAY OPTION			ON	ON	ON	ON	ON

Price of Play settings for South Africa

			1	2	3	4	5
1 R play	5 R = 5 CR	10 R = 10 CR	OFF	OFF	OFF	OFF	OFF
1 R play	5 R = 5 CR	10 R = 11 CR	ON	OFF	OFF	OFF	OFF
1 R play	5 R = 6 CR	10 R = 12 CR	OFF	ON	OFF	OFF	OFF
2 R play	5 R = 2.5 CR	10 R = 5 CR	ON	ON	OFF	OFF	OFF
2 R play	5 R = 3 CR	10 R = 6 CR	OFF	OFF	ON	OFF	OFF
2 R play	5 R = 3 CR	10 R = 7 CR	ON	OFF	ON	OFF	OFF
3 R play	5 R = 1.6 CR	10 R = 3.3 CR	OFF	ON	ON	OFF	OFF
3 R play	5 R = 2 CR	10 R = 4 CR	ON	ON	ON	OFF	OFF
3 R play	5 R = 2 CR	10 R = 5 CR	OFF	OFF	OFF	ON	OFF
4 R play	5 R = 1.25 CR	10 R = 2.5 CR	ON	OFF	OFF	ON	OFF
4 R play	5 R = 1.25 CR	10 R = 3 CR	OFF	ON	OFF	ON	OFF
5 R play	5 R = 1 CR	10 R = 2 CR	ON	ON	OFF	ON	OFF
5 R play	5 R = 1 CR	10 R = 3 CR	OFF	OFF	ON	ON	OFF
6 R play	5 R = 0.83 CR	10 R = 1.25 CR	ON	OFF	ON	ON	OFF
6 R play	5 R = 0.83 CR	10 R = 2 CR	OFF	ON	ON	ON	OFF
8 R play	5 R = 0.62 CR	10 R = 1.25 CR	ON	ON	ON	ON	OFF
10 R play	5 R = 0.5 CR	10 R = 1 CR	OFF	OFF	OFF	OFF	ON
10 R play	5 R = 0.5 CR	20 R = 2	ON	OFF	OFF	OFF	ON
20 R play	5 R = 0.25 CR	10 R = 0.5 CR	OFF	ON	OFF	OFF	ON
20 R play	5 R = 0.25 CR	10 R = 0.5 CR 50 R = 3 CR	ON	ON	OFF	OFF	ON
30 R play	NO BONUSES		OFF	OFF	ON	OFF	ON
30 R play		50 R = 3 CR	ON	OFF	ON	OFF	ON
50 R play	NO BONUSES		OFF	ON	ON	OFF	ON
50 R play		100 R = 3 CR	ON	ON	ON	OFF	ON
FREE PLAY OPTION			ON	ON	ON	ON	ON

METER OPERATES ON 1 RAND = 1 PULSE
 COIN 1 = 5 RAND, COIN 2 = 2 RAND, COIN 3 = 1 RAND

Appendix B - Names of parts and list of main parts

• Main Machine

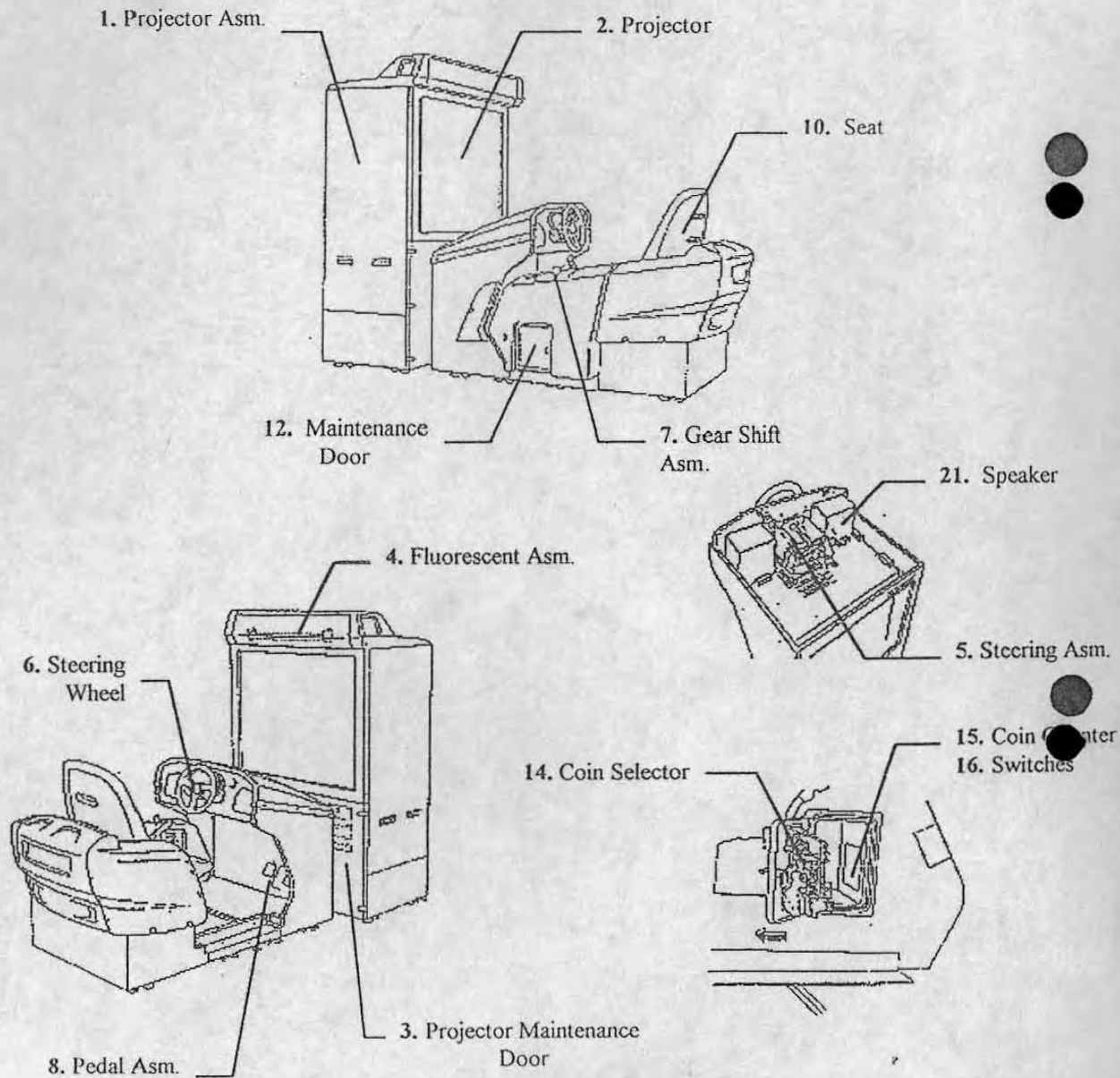

• Replacement part numbers

No.	Part name	Part code	Quantity	Remarks
1	Projector Unit Assembly	381839	1	
2	Projector	10205	1	
3	Projector Unit maintenance door	203548	1	
4	Fluorescent light unit	381776	1	
5	Steering Unit Assembly	381845	1	
6	Steering wheel	21241	1	
7	Gear Shift Unit Assembly	31665	1	
8	Pedal Unit Assembly	381743	1	
9	Handbrake Unit Assembly	381849	1	
10	Seat	341943	1	
11	Maintenance door	50614	1	Coin Acceptor Door
12	Maintenance door	50228	1	Coin Box Door
13	Coin Box	203511	1	
14	Coin Selector	50578	1	UK version
15	Coin Counter	50003	1	12v Meter
16	Service Panel switch	45A020	2	
17	Switch Mode PSU	14031	1	5v Logic Supply
18	Switch Mode PSU	14032	1	12v Logic Supply
19	Switch Mode PSU	14033	1	12v Motor Supply
20	Transformer (110v)	15052	1	Projector Supply
21	Speaker	56036	2	
22	View shift switch	22485	1	
23	AT / MT switch	22487	1	
24	Mains Power switch	45A020	1	
25	Mains Isolation switch	45A001	1	
26	Mains Power Cord	162189	1	

• Steering Assembly - Part No : 381845

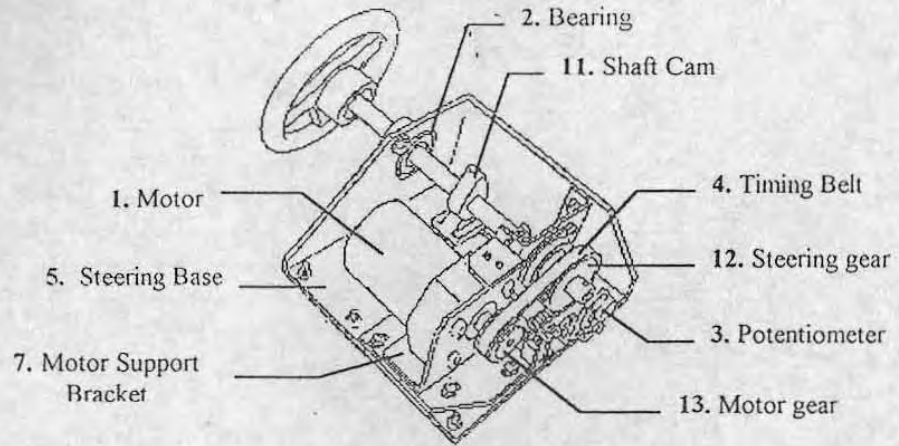

No.	Part name	Part code	Quantity	Remarks
1	Motor	51028	1	
2	Bearing	31649	2	
3	Potentiometer	42100	1	
4	Timing Belt	31663	1	
5	Steering Base	203634	1	
6	Steering wheel Shaft	203638	1	
7	Motor Support Bracket	203635	1	
8	Steering Support Bracket	203639	1	
9	Potentiometer Bracket	203834	1	
10	Shaft Stopper	541971	1	
11	Shaft Cam	203642	1	
12	Steering Gear	31704	1	
13	Motor Gear	31703	1	

MAINS IN SWITCH
PART No: 45A0020

MAINS FILTER
PART No: 80004

MAINS ISOLATION SWITCH
PART No: 45A0021

TRANSFORMER
PART No: 15052

5V LOGIC SUPPLY
PART No: 14031

12V LOGIC SUPPLY
PART No: 14032

12V MOTOR SUPPLY
PART No: 14033

LIGHT UNIT
PART No: 301776

PROJECTOR
PART No: 10205

GTI GAME BOARD
PART No: 11334

COLOUR CODE	
BLK	BLACK
BRN	BROWN
RED	RED
ORG	ORANGE
YEL	YELLOW
GRN	GREEN
BLU	BLUE
VIO	VIOLET
GRY	GREY
WHI	WHITE

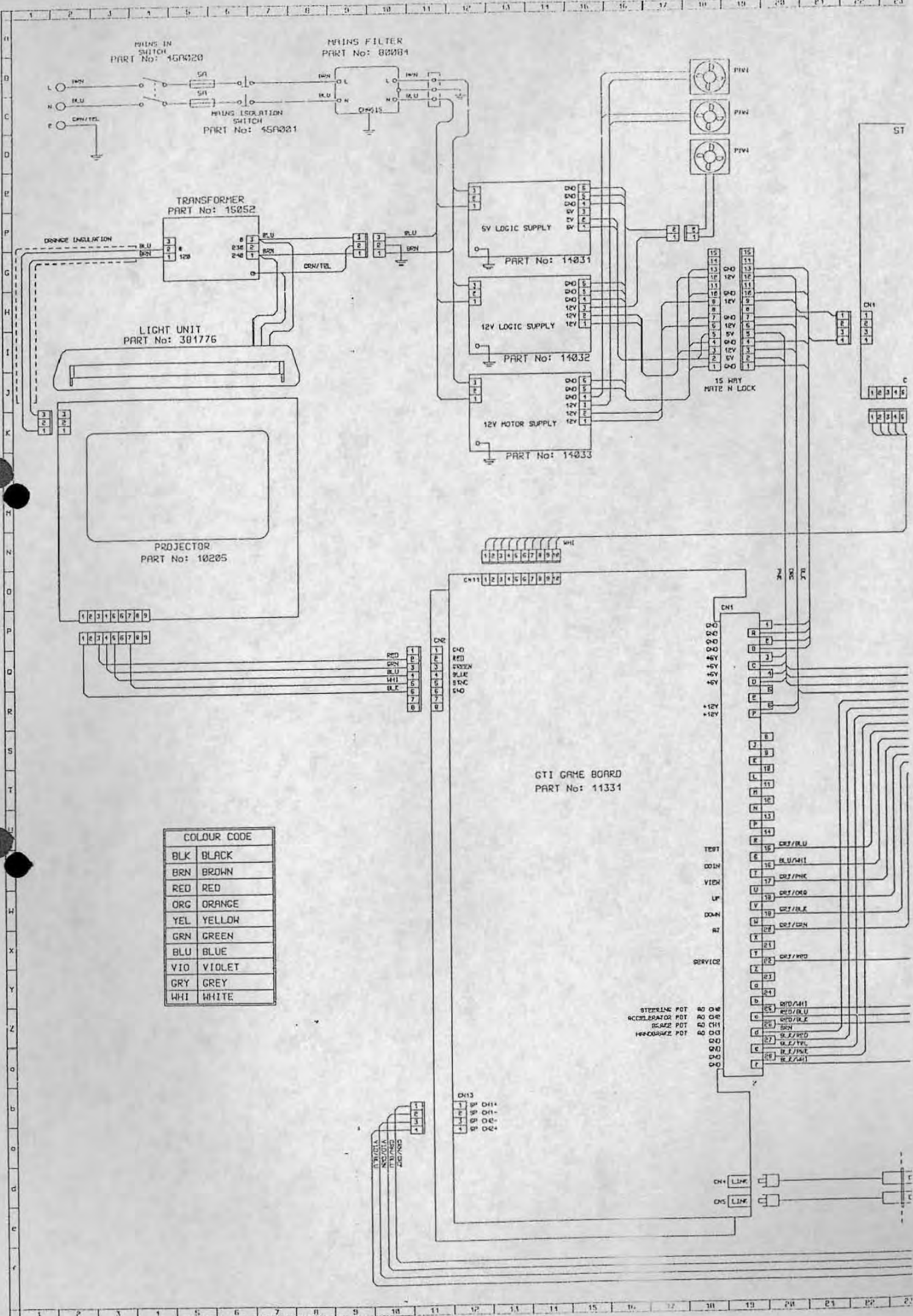

CH2
1 1
2 2
3 3
4 4
5 5
6 6
7 7
8 8
9 9

CH3
1 1
2 2
3 3
4 4

CH1
1 1
2 2
3 3
4 4
5 5
6 6
7 7
8 8
9 9
10 10
11 11
12 12
13 13
14 14
15 15
16 16
17 17
18 18
19 19
20 20
21 21
22 22
23 23
24 24
25 25
26 26
27 27
28 28

TEST
DOWN
VIEW
UP
DOWN
RT
SERVICE

STEERING POT AO CH2
ACCELERATOR POT AO CH2
BRAKE POT AO CH1
100% BRAKE POT AO CH3

CH1
CH2
CH3

1 2 3 4 5 6 7 8 9 10 11 12 13 14 15 16 17 18 19 20 21 22 23 24 25 26 27 28 29 30 31 32 33 34 35 36 37 38 39 40 41 42 43 44 45 46 47 48 49 50 51 52 53 54 55 56 57 58 59 60 61 62 63 64 65 66 67 68 69 70 71 72 73 74 75 76 77 78 79 80 81 82 83 84 85 86 87 88 89 90 91 92 93 94 95 96 97 98 99 100

ERING REACTION DEVICE
DRIVE BOARD
PART No: 11317

GEAR SHIFT ASSEMBLY
PART No: 31665

LAMP

COIN LAMP

AT/MT

COIN ACCEPTOR
PART No: 50578

SERVICE TEST

CREDIT BOARD
PART No: 12562

COUNTER
PART No: 50803

MASCOT ALARM UNIT
PART No: 12532

HANDBRAKE UNIT

HANDBRAKE

PEDAL ASSEMBLY
PART No: 381743

STEERING ASSEMBLY
PART No: 381845

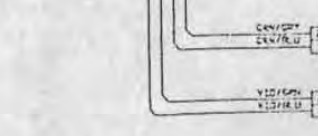
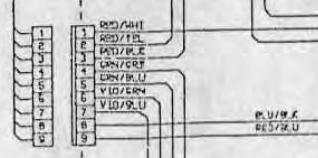
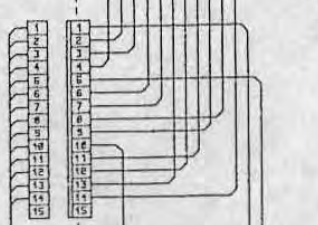
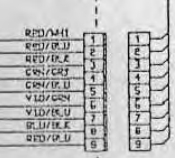
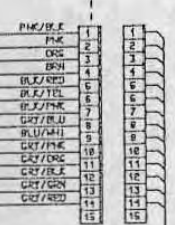
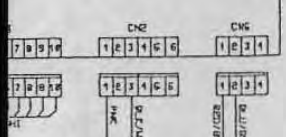

GTI CLUB DELUXE (C) KORNVI 1996
APPENDIX C DRAWN BY: JJ8 (ECA)