

**DC DATA
EAST**

**CAPTAIN
AMERICA**
and The AVENGERS

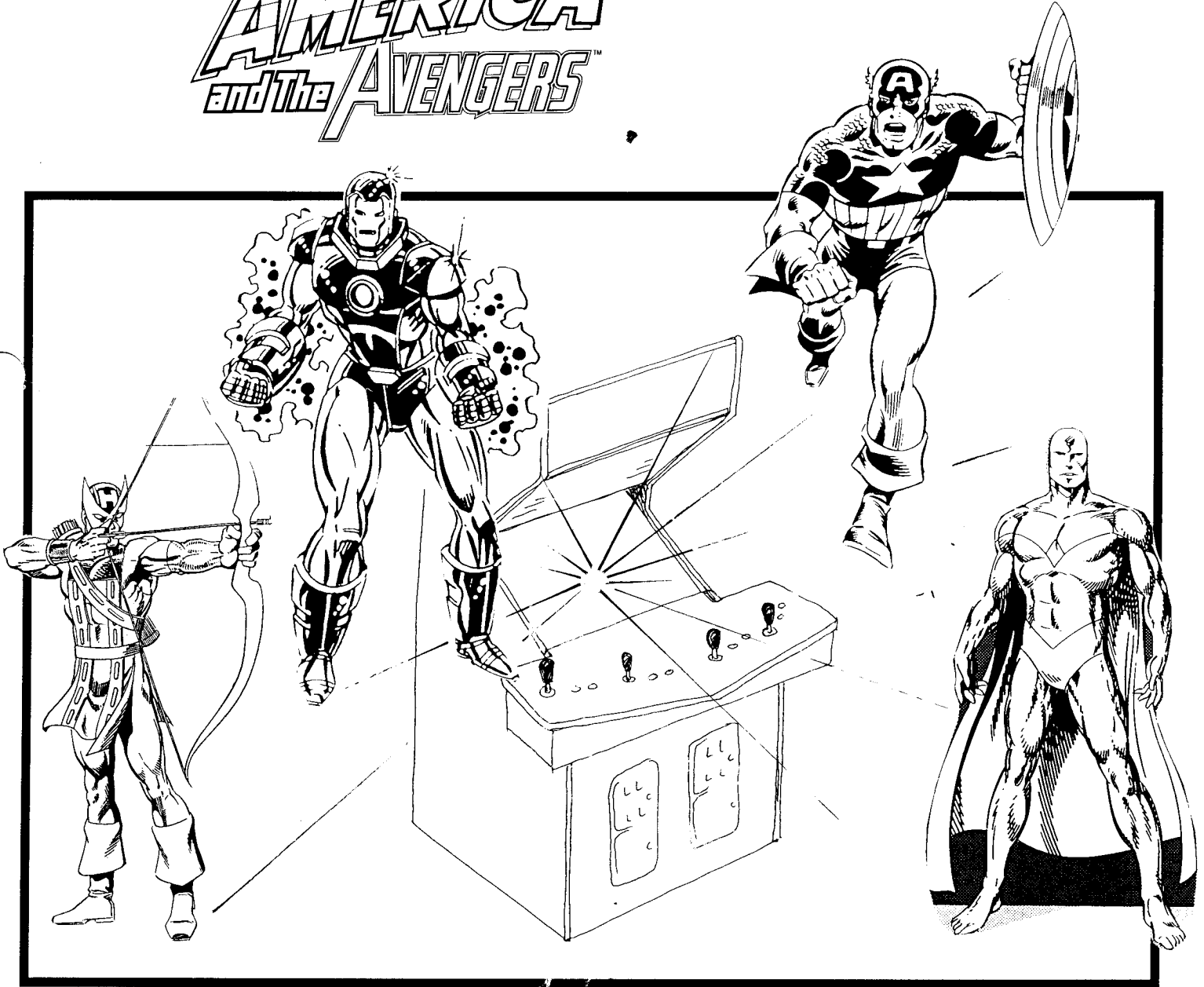

Owner's Manual

1850 Little Orchard Street, San Jose, Ca. 95125-1045 (408) 286-7080 Fax (408) 971-0722
Customer Service (800) 634-7270

P/N 780-0210-00
Rev. 1.0 8/15/91



ERRATA SHEET FOR
CAPTAIN AMERICA AND
THE AVENGERS MANUAL
NO. 780-0210-00
INITIAL RELEASE

The Captain America and the Avengers Game has been changed slightly in Data East's efforts to constantly improve the product that we ship to you. Please keep this errata sheet with your manual or mark the manual to reflect these changes:

Page	Correction
11	Replacement Parts List Item 2 (Harness, Control Panel) under Control Panel Assembly should be Part Number 036-0318-01.
12	Replacement Parts List Items 21 (Harness, Speaker -- Part Number 036-0273-00) and 22 (Harness, Monitor -- Part Number 036-0277-00) are now included in the Main Harness Assembly and can not be bought as separate items.
15	The Video Monitor Connector (CN14) has had the position numbers reversed. Position 1 in the manual is now position 10, position 2 is now position 9 and so forth.



● TABLE OF CONTENTS

Operation & Installation

DISCLAIMERS AND SAFETY GUIDE	1
GAME SPECIFICATIONS	3
GAME DESCRIPTION	3
INSPECTION & SET-UP	6
DIP SWITCH CHARTS	7

Operation & Installation

Appendix A — Replacement Parts

REPLACEMENT PARTS LIST	11
------------------------------	----

APPENDIX A
Replacement Parts

Appendix B — Wiring Diagrams

INTERCONNECT DIAGRAM 1.....	15
INTERCONNECT DIAGRAM 2.....	16

APPENDIX B
Wiring Diagrams

DISCLAIMERS & SAFETY GUIDE

The following safety precautions apply to all game operators and service personnel. Specific warnings and cautions will be found in this manual whenever they apply.

WARNING

Properly Ground the Game

Players may receive an electrical shock if this game is not properly grounded! To avoid electrical shock, do not plug in the game until it has been inspected and properly grounded. This game should only be plugged into a grounded three-wire outlet. If you have only a two-wire outlet, we recommend you hire a licensed electrician to install a three-wire grounded outlet. If the coin door is not properly grounded, players may receive an electrical shock! After servicing any part on the doors, check that the grounding wire is firmly secured to the inside of the control panel. After you have verified this, lock up the game.

AC Power Connection

Before you plug in the game, be sure that the game's power supply can accept the AC line voltage in your location. The line voltage requirements are contained within this manual.

Disconnect Power During Repairs

To avoid electrical shock, disconnect the game from the AC power before removing or repairing any part of the game. The power supply capacitors retain energy for a period of time even after AC power is removed. Use care when working near them or on any circuitry connected to them.

Use the Proper Fuses

To avoid electrical shock, use replacement fuses which are specified in the parts list for this game. Replacement fuses must match those replaced in fuse type, voltage rating, and current rating. In addition, the fuse cover must be in place during game operation.

CAUTION**Properly Attach All Connectors**

Make sure that the connectors on each printed circuit board (PCB) are properly plugged in. The connectors are keyed to fit only one way. If they do not slip into place easily, do not force them. If you reverse a connector, you may damage your game and void your warranty.

NOTICE REGARDING NON-DATA EAST PARTS**WARNING**

Use of non-DATA EAST parts or modifications of any DATA EAST game circuitry may adversely affect the safety of your game, and may cause injury to you and your players.

Note: This equipment generates, uses, and can radiate radio frequency energy, and if not installed and used in accordance with the instruction manual, may cause interference to radio communications. It has been tested and found to comply with the limits for a Class A computing device pursuant to Subpart J of Part 15 of Federal Communications Commission (FCC) Rules, which are designed to provide reasonable protection against such interference when operated in a commercial environment. Operation of this equipment in a residential area or modification to this equipment is likely to cause interference, in which case the user, at his own expense, will be required to take whatever measures may be required to correct the interference. If you suspect interference from a DATA EAST game at your location, check the following:

All ground wires in the game are properly connected as shown in the game wiring diagram.

The power cord is properly plugged into a grounded three wire outlet.

GAME SPECIFICATIONS

Characteristic	Specifications
Power consumption	250 VA , 110 V RMS
Temperature	+5 to +50 degrees C (+37 to +122 degrees F)
Humidity	Not to exceed 95% relative
Line Voltage	102 to 132 VAC(U.S. games)
Width	40"
Depth	36"
Height	72"
Weight	300 lbs.

Table 1-1. Game Specifications

GAME DESCRIPTION

Congratulations! You have just purchased a video game which stars Marvel™ superhero characters. Captain America and the other Avengers have been popular comic book characters for many years. Now, in your new game these characters have been brought to life, and for just a coin or two (or two hundred!) your customers can live the adventures of Captain America, Iron Man™, Vision™ or Hawkeye™. A few other Avenger characters show up briefly in the game, notably Wonder Man™, Sub-Mariner™, and Quicksilver™.

During the game, players meet many well known super villians from the pages of the Avenger's comic books. In the game, Red Skull™ is the Avenger's chief nemesis. In a plot to rule the world he has used a mind-control device to enslave various super villians to serve him.

The player must skillfully operate the Avenger of his choice to battle his way through such formidable foes as Ultron™, Mandarin™, Grim Reaper™, Whirlwind™, Living Laser™, Klaw™, and even Jugger-naut™ and a Sentinal™. Red Skull™ and his right hand man, Crossbones™, are the last enemies the players must meet and defeat.

The game has 5 stages, including a few "shooting" sections in which the Avengers must fly, either under their own power or with small "skysleds", and fire their weapons at attacking enemies.

HOW TO PLAY

Captain America and The Avengers is simple to play and is similar in many respects to other popular coin-op games. It is a 4 player game, with each coin slot corresponding to a specific Avenger. The player selects the Avenger he wishes to play and controls his Avenger with an 8-way joystick and 2 buttons.

The following basic instructions are printed on the game's control panel.

CAPTAIN AMERICA and THE AVENGERS

- 1-4 players
- Insert coin(s) in the slot that goes with the Avenger of your choice, press Start/Attack to start.
- CONTROLS:



8-way joystick



Start/Attack



Jump

More detailed Instructions on how to control the Avenger's movements and actions are illustrated on the next page. These instructions appear on the underlay card.

HOW TO PLAY

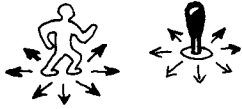

Walk. Hold the joystick in the direction you wish to walk. All Avengers.

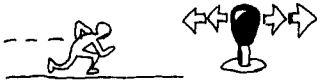

Run left or right. Tap joystick twice (not too rapidly) in the direction you wish to run. All Avengers.



Ram or power-slide. When running (see above), press S/A (Start/Attack) button to bash into enemies. All Avengers ram except Hawkeye, who power-slides.



Close-range attack. Move close to an enemy and press S/A button repeatedly. Note: characters must be lined up on the horizontal axis to hit each other. All Avengers.

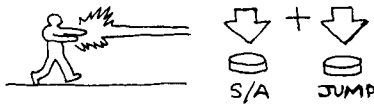

Fire Weapon. Press both S/A and Jump buttons at the same time. Each Avenger has a different projectile attack.



Pick up enemies and certain objects and throw them. Use joystick to move Avenger under and into enemy/object, press S/A the moment you make contact. Press S/A again to throw the enemy or object. All Avengers.



Jump. Press Jump button. Use joystick to control movement direction to some extent in mid-jump. All Avengers.



Diving attack. Press jump and then immediately press S/A. All Avengers.

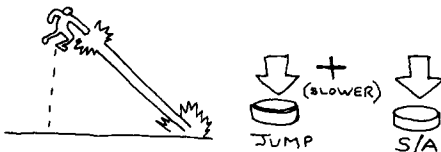

Jump and attack. Press Jump then press S/A near apex of jump. Cap and Hawkeye perform a kicking attack, Iron Man and Vision fire repulsors or lasers at an angle.



Defense against enemy projectiles. Hold S/A button down. All Avengers. Note: Vision's defense is to become immaterial.

INSPECTION AND SET-UP

WARNING

Do not plug in the game until you have completed the following inspection steps.

CAUTION

Before You Power Up, inspect the game cabinet as follows:

1. Examine the exterior of the cabinet for dents, chips, or broken parts.
2. Unlock and open the coin door and rear service door.
3. Ensure that all plug-in connectors inside the rack are firmly plugged in. Do not force connectors together. The connectors are keyed so they fit only in the proper orientation. A reversed edge connector can damage a printed-circuit board (PCB) and will void your warranty.
4. Ensure that all plug-in integrated circuits on the Main PCB are firmly plugged into their sockets.
5. Inspect the power cord for any cuts or dents in the insulation.
6. Inspect the power supply. Make sure that the correct fuses are installed. Check that the harness is plugged in correctly and that the fuse block cover is mounted in place. Check that the green ground wires are connected.
7. Inspect other major sub-assemblies, such as the printed circuit boards, speaker, ticket drive, coin door, etc. Make sure that they are mounted securely and that the ground wires are connected.
8. If the above steps have been completed and all game functions are working properly then you can power up the game.

OPERATOR SELECTABLE OPTIONS

		DIP SWITCH 1								
FUNCTION		SWITCH SETTING								REMARKS
		1	2	3	4	5	6	7	8	
GAME CHARGE	1COIN=1CREDIT	OFF	OFF	OFF						COIN/CREDIT COIN MECH 1
	1COIN=2CREDIT	ON	OFF	OFF						
	1COIN=3CREDIT	OFF	ON	OFF						
	1COIN=4CREDIT	ON	ON	OFF						
	1COIN=5CREDIT	OFF	OFF	ON						
	1COIN=6CREDIT	ON	OFF	ON						
	2COIN=1CREDIT	OFF	ON	ON						
	3COIN=1CREDIT	ON	ON	ON						
GAME CHARGE	1COIN=1CREDIT				OFF	OFF	OFF			COIN/CREDIT COIN MECH 2
	1COIN=2CREDIT				ON	OFF	OFF			
	1COIN=3CREDIT				OFF	ON	OFF			
	1COIN=4CREDIT				ON	ON	OFF			
	1COIN=5CREDIT				OFF	OFF	ON			
	1COIN=6CREDIT				ON	OFF	ON			
	2COIN=1CREDIT				OFF	ON	ON			
	3COIN=1CREDIT				ON	ON	ON			
SCREEN ROTATION	NORMAL							OFF		
	REVERSE							ON		
CONTINUE COIN	1COIN START/1CONTIN.								OFF	
	2COIN START/1CONTIN.								ON	

Table 1 Dip Switch 1 Settings

		DIP SWITCH 2								
FUNCTION		SWITCH SETTING								REMARKS
		1	2	3	4	5	6	7	8	
NUMBER OF LIVES	1	OFF	ON							
	2	ON	ON							
	3	OFF	OFF							
	4	ON	OFF							
GAME DIFFICULTY	NORMAL			OFF	OFF					
	EASY			ON	OFF					
	HARD			OFF	ON					
	HARDEST			ON	ON					
COIN SWITCHES	1 OR 2 SWITCH INPUT					OFF				
	1-4 SWITCH INPUT					ON				
MODE SELECT	2-PLAYER MODE						OFF			
	4-PLAYER MODE						ON			
CONTINUE MODE	YES							OFF		
	NO							ON		
ATTRACT MODE SOUND	YES								OFF	
	NO								ON	

Table 2 Dip Switch 2 Settings

REPLACEMENT PARTS LIST

Control Panel Assembly, Avengers	510-0236-00
1. Control Panel Overlay	800-0064-00
2. Harness, Control Panel	036-0318-00
3. Harness, Control Panel	036-0318-02
4. Pushbutton Assembly, Red	180-0024-02
5. Pushbutton Assembly, Blue	180-0024-06
6. Switch (for Pushbutton Assemblies)	180-0017-00
7. Joystick	450-0015-51
8. Control Panel Base	366-0099-00
9. Control Panel Top	366-0100-00
10. Control Panel Retainer	535-0196-00
11. Hook, Latch (part of Latch from cabinet)	355-0005-00
Cabinet Parts	
1. Marquee Plex	830-0059-00
2. Decal, Left Side, Avengers	820-0071-01
3. Decal, Right Side, Avengers	820-0071-02
4. Label Set, Coin Door, Avengers	406-0488-00
5. Underlay, Monitor, Avengers	810-0057-00
6. Bezel, Black 25"	380-0005-00
7. Plex, Clear, Monitor	660-0014-03
8. Retainer, Plex, Top	535-0195-00
9. Retainer, Plex, Bottom	535-0201-00
10. Printed Circuit Board Assembly	510-0237-00
11. Power Supply	001-0016-00
12. Isolation Transformer, Monitor	010-0009-00
13. Coin Door Assembly (Coin Controls Mfg. P/N 10-4993-09)	510-0232-00
14. Plastic Cash Box	545-0045-00
15. Cover, Plastic Cash Box	535-0233-00
16. Service Panel Assembly	515-0105-00
A. Coin/Ticket Counter	090-0002-00
B. Potentiometer, Volume Control	123-0008-11
C. Switch, Pushbutton, Red (Test)	180-0024-02
D. Switch (for Pushbutton Assemblies)	180-0017-00
E. Harness, Service Panel	036-0321-00
F. Plate, Service Panel	535-0232-01
17. Speaker, 5 x 7, 16 ohm	031-0007-00
18. Bulb, Incandescent, 40 W (Marquee)	165-0004-01
19. Socket, Lamp (for 40 W Bulb)	170-0002-00

REPLACEMENT PARTS LIST (Con't)

20. Harness, Marquee Lamp	036-0319-00
21. Harness, Speaker	036-0273-00
22. Harness, Monitor	036-0277-00
23. Harness, Main (JAMMA)	036-0320-00
24. On/Off Switch Assembly	515-0084-00
A. Switch Mounting Plate	535-0082-00
B. Switch, Toggle	180-0023-00
C. Harness, Switch Plate	036-0278-00
25. Fish Paper, Power Shield	660-0003-00
26. Leg Levelers, 3/8 x 1-1/4 Long	400-0003-00
27. Hinge (for Control Panel)	390-0002-00
28. Latch (for Control Panel)	355-0005-00

INTERCONNECT DIAGRAM 1

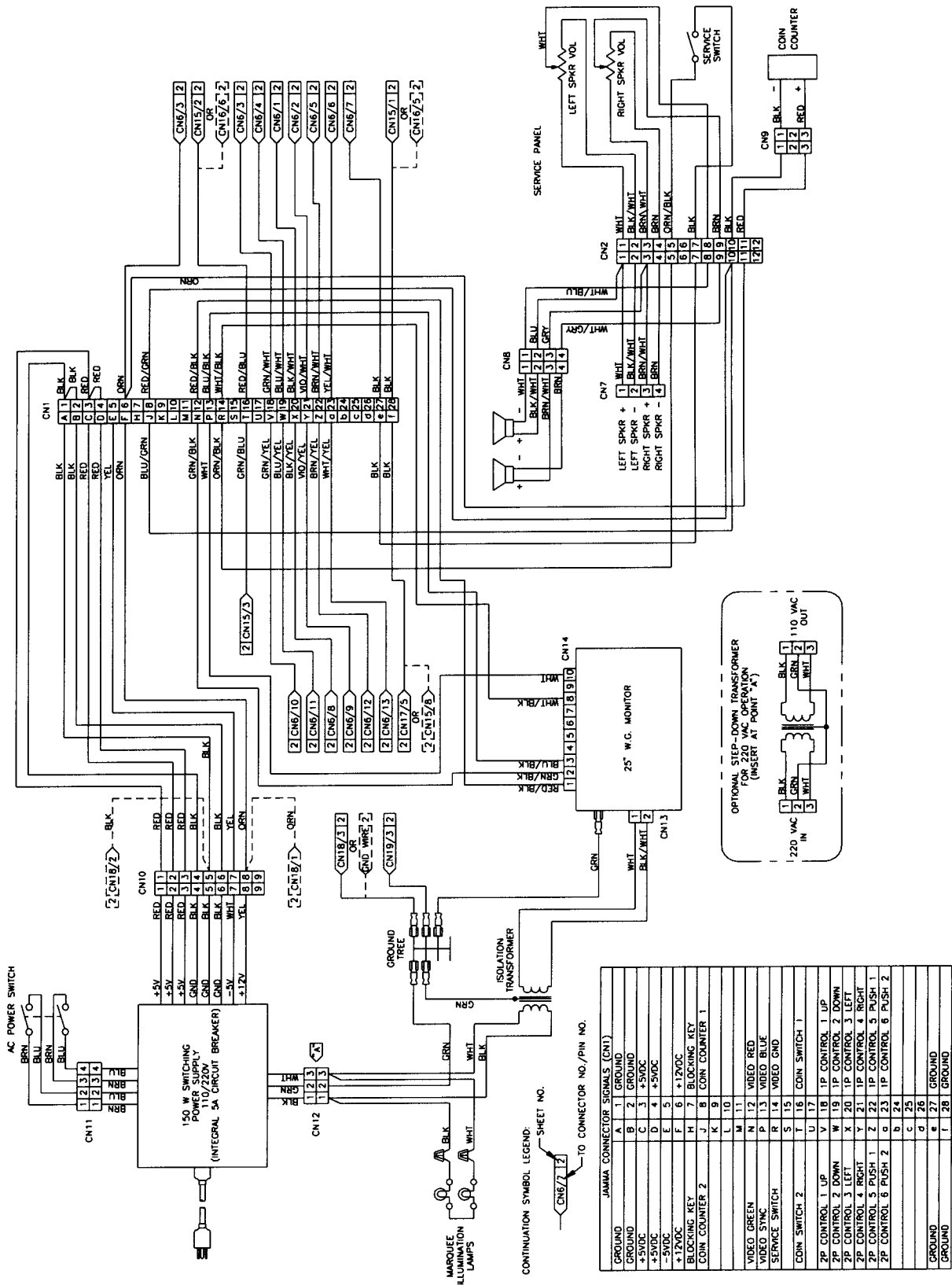

INTERCONNECT DIAGRAM 2

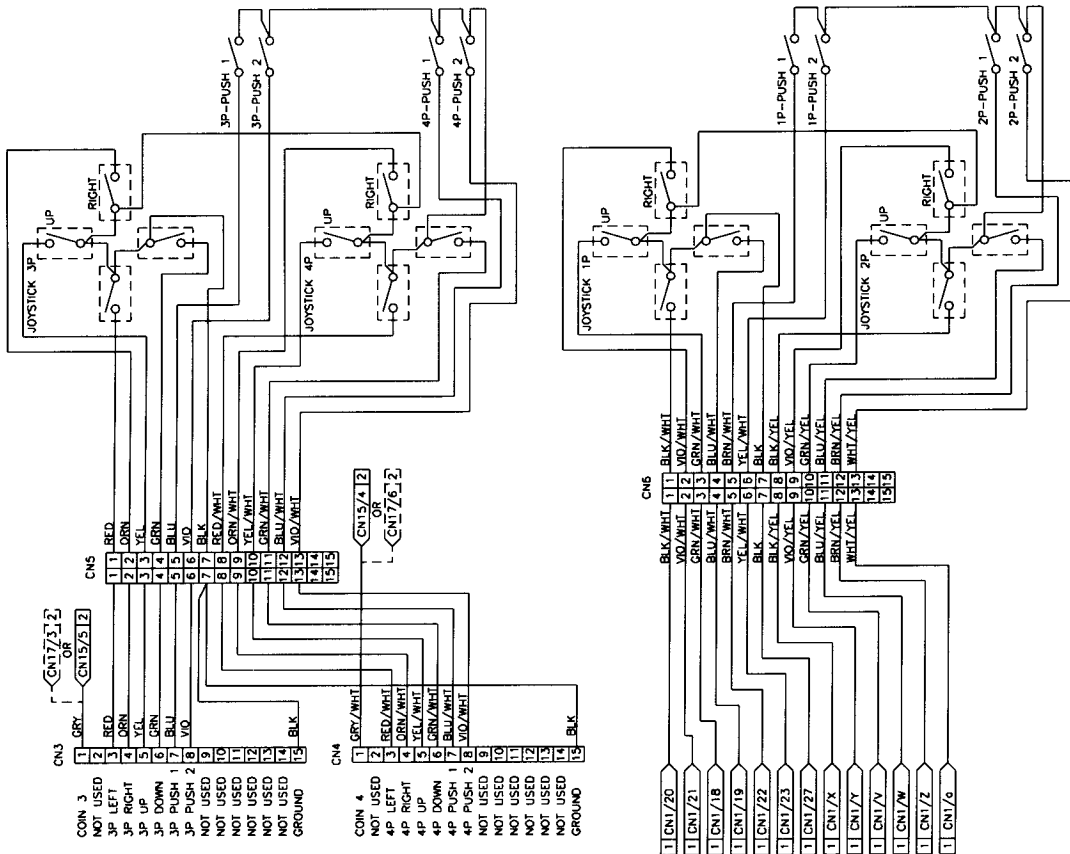
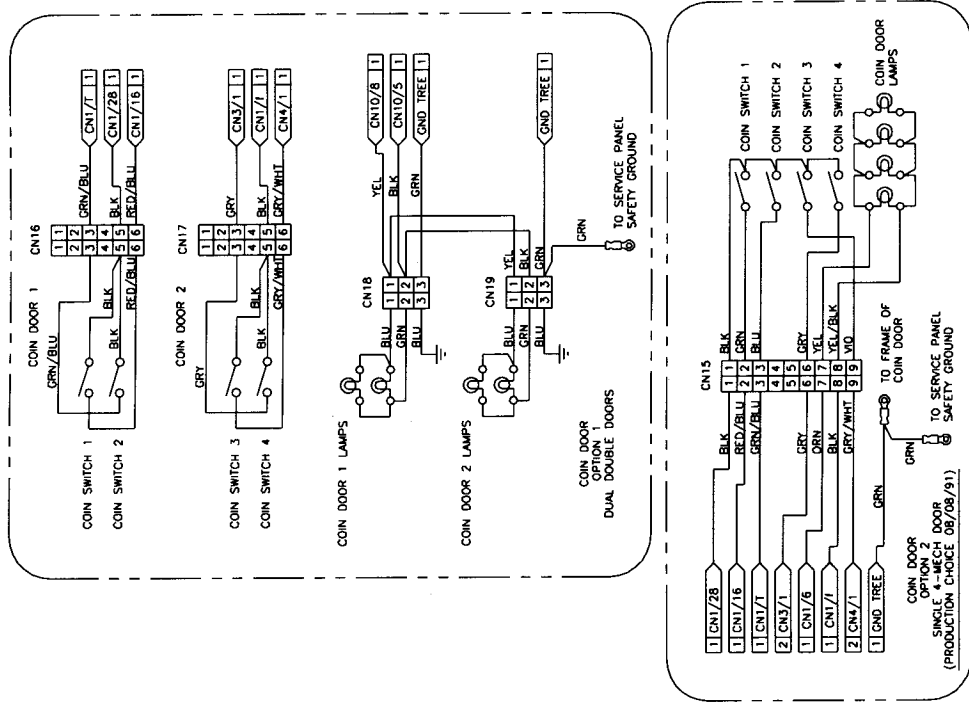

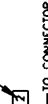
CONTINUATION SYMBOL LEGEND:
 SHEET NO.
 TO CONNECTOR NO./PIN NO.