

SEGA®

AFTER BURNER

DELUXE TYPE

OWNER'S MANUAL



SEGA ENTERPRISES, LTD.

TABLE OF CONTENTS

INTRODUCTION OF THE OWNER'S MANUAL	1
1. HANDLING PRECAUTIONS	1
2. PREVENTION OF COUNTERFEITING AND CONVERSION	2
3. PRECAUTIONS CONCERNING THE PLACE OF INSTALLATION	3
4. NAME OF PARTS	4
5. BREAKER	5
6. PRECAUTIONS FOR INSTALLING AND MOVING THE MACHINE	6
7. REMOVING THE COIN CHUTE TOWER	7
8. ADJUSTING THE SEAT POSITION	8
9. REMOVING THE HANDLE UNIT	9
10. ADJUSTING THE HANDLE UNIT	10
11. REMOVING THE LAMP BOX	11
12. OPENING THE MECHANISM BASE	12
13. REMOVING THE ROLLING MOTOR UNIT	13
14. REMOVING THE PITCHING MOTOR UNIT	14
15. REPLACING THE MOTOR BRUSHES	15
16. ROLLING ADJUSTMENTS	16 • 17
17. PITCHING ADJUSTMENTS	18 • 19
18. REMOVING THE IC BOARD	20
19. SERVICE SWITCH FUNCTIONS	21
20. 20 INCH MONITOR	22
21. DIP SWITCH SETTING	23
22. EPROM/MASK ROM LOCATIONS	24
23. PARTS LIST	25~62
24. WIRING DIAGRAM	63 • 64

SPECIFICATIONS

- | | |
|----------------------|--|
| • INSTALLATION SPACE | : 2000 mm (78.7in) (D) × 1325 mm (52.5in) |
| • HEIGHT | : 1750 mm (68.9in), 1880 mm (74.0in) (MAX) |
| • POWER | : 480 W |
| • C. R. T | : 20 INCH |
| • WEIGHT | : 430 kg (946 lbs.) |

NOTE

o Descriptions herein contained may be subject to improvement changes without notice.

INTRODUCTION OF THE OWNER'S MANUAL

SEGA ENTERPRISES, LTD., supported by its high electronic technology of LSIs, microprocessors, etc. and a wealth of experience, has for more than 30 years been supplying various innovative and popular game machines to the world market. The OWNER'S manual is intended to provide detailed comments together with all the necessary information covering the operation in general of electronic assemblies, electromechanicals servicing control, spare parts, etc. as regards the AFTER BUR a new SEGA product. The manual is intended for those who have knowledge of electricity and technical expertise especially ICs, CRTs, microprocessors, etc. Carefully read so as to acquire sufficient knowledge before working on the machine. Should there be a malfunction, non-technical personnel should under no circumstance touch the interior system.

1. HANDLING PRECAUTIONS

When installing or inspecting, be very careful of the following points and pay attention to ensure that the player can enjoy the game safely.

- o Be sure to turn the power off before working on the machine
- o To insert or pull out the plug quickly is dangerous.
- o It is necessary to make sure that the power cord or the grounding wire is not exposed on the road, etc. in a manner so as to be dangerous. Make sure that grounding connections are made safely at the position where so specified.
- o Do not use any fuse that does not meet the specified rating
- o Make complete connections for the IC board and other connectors. Insufficient insertion is very dangerous.

Also, for the IC board circuit inspections, only the logic probe is allowed. The use of a tester is not permitted, so be careful in this regard. After confirming that there are no irregularities, turn the power ON.

2. PREVENTION OF COUNTERFEITING AND CONVERSION

LABELLING

To prevent counterfeits and conversions, the following labels are put on all the SEGA products. When handling such goods, be sure to confirm the labels. They are used to prevent illegal acts such as the unauthorized copying of the products and the printed circuit boards thereof or carrying on business by manufacturing similar merchandise or by converting, selling or using such products or printed circuit boards.

ORIGINAL SEAL

The following seal is put on the machines manufactured by SEGA.



LICENSE SEAL

The following seal is put on the kits, such as the printed circuit boards, of SEGA products.



COPYRIGHT NOTICE

This SEGA product has the copyright notice as follows:

© SEGA 1987

This signifies that this work was disclosed in 1987 and is the property of SEGA ENTERPRISES, LTD.

3. PRECAUTIONS CONCERNING THE PLACE OF INSTALLATION

The AFTER BURNER is an indoor game machine. Absolutely do not install it outside. Even indoors, avoid installing in places mentioned below so as to ensure proper usage:

- o Places subject to rain or water leakage, or condensation and to humidity.
- o In the proximity of an indoor swimming pool and/or shower.
- o Places subject to direct sunlight.
- o Places subject to heat sources from heating units, etc., or hot air.
- o Vicinity of highly inflammable/volatile chemicals or hazardous matter.
- o Sloped surfaces.
- o Vicinity of anti-disaster facilities such as fire exits and fire extinguishers.
- o Places subject to any type of violent impact.
- o Dusty places.

PRECAUTIONS FOR INSTALLATION

1. For purposes of your customers' safety and protection, providing the TX-0023 GUARD FENCE (optional) around the machine's immediate surrounding area is recommended.
2. Make sure that the power supply outlet is used exclusively for the AFTER BURNER. (The outlet's simultaneous use for other machine(s) may cause the breaker to break when the power consumption exceeds the maximum).
3. An extension cord used shall be of a 15A rated current or higher.

The machine's consumption current

Rated current	:	1A (100V AC)
(standby)		
Maximum	:	15A (100V AC)
During game play:		2.5 15A (100V AC)

4. NAME OF PARTS

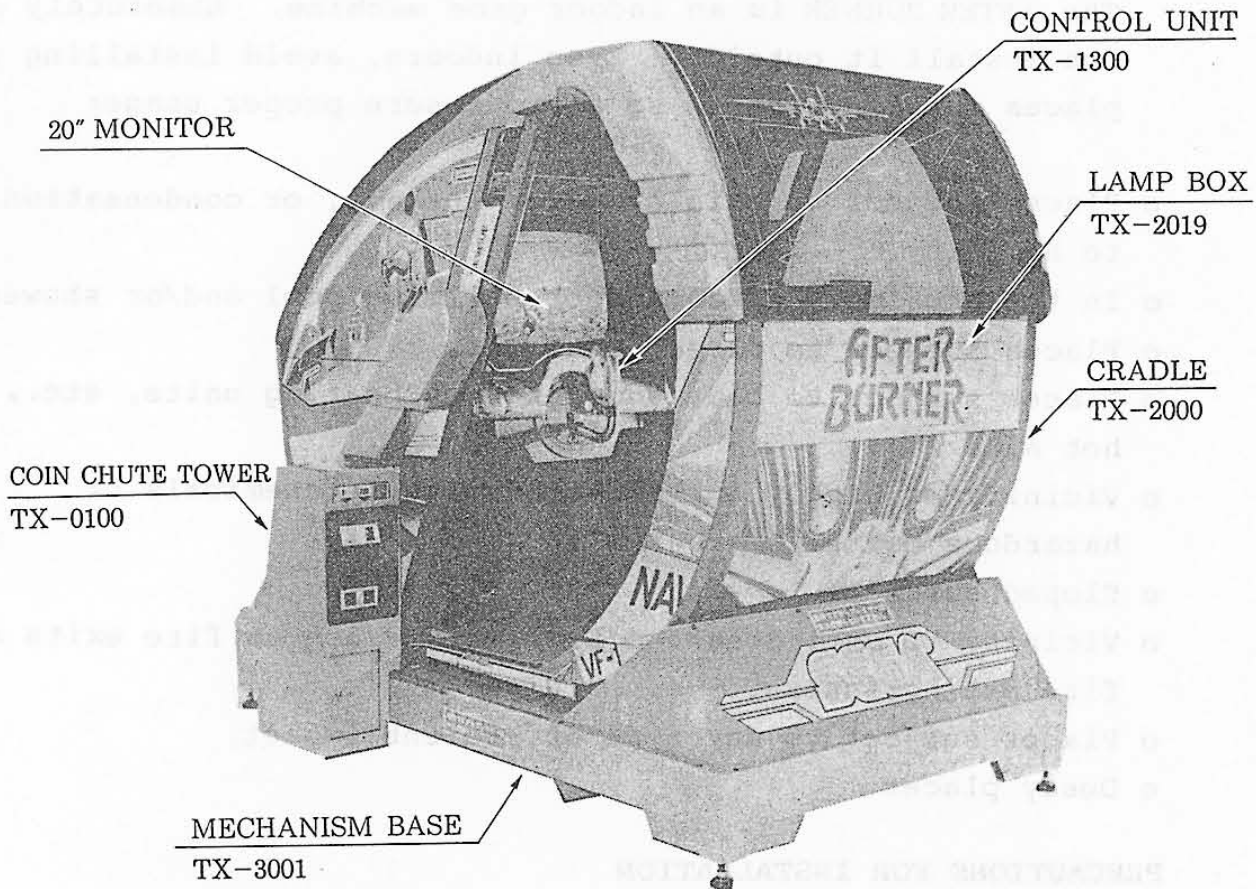

SPARE PARTS

- 601-5910 BRUSH FOR MOTOR (FOR PITCHING MOTOR)
- 601-5911 BRUSH FOR MOTOR (FOR ROLLING MOTOR)
- TX-1317 EXT. SPRING (FOR HANDLE UNIT)
- 390-5167 LAMP 110V, 30W (FOR RANGER LAMP)
- 220-5130 VOL CONT B-5KOHM (FOR HANDLE, ROLLING AND PITCHING ADJUSTMENTS)
- 540-0006-01 WRENCH FOR TAMPER SCREW M4
- 540-0007-01 WRENCH FOR TAMPER SCREW M5

TOOLS

(TAMPERPROOF WRENCH)

- M4 540-0006-01
- M5 540-0007-01

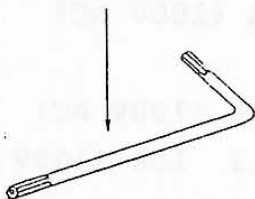

(TAMPERPROOF DRIVER)

- M4 540-0018
- M5 540-0017

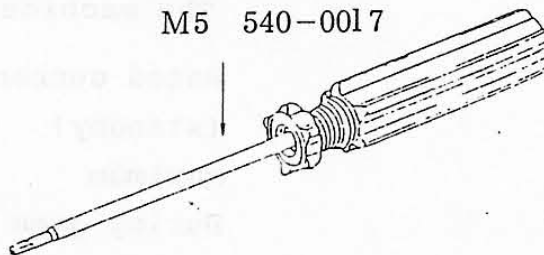

5. BREAKER

When the machine is overloaded, the breaker functions and the machine will stop. In such a case, check the breaker shown below, and if it is protruding, this signifies that the breaker has performed its function. After finishing checking, push it forward to restore the breaker to its original position.

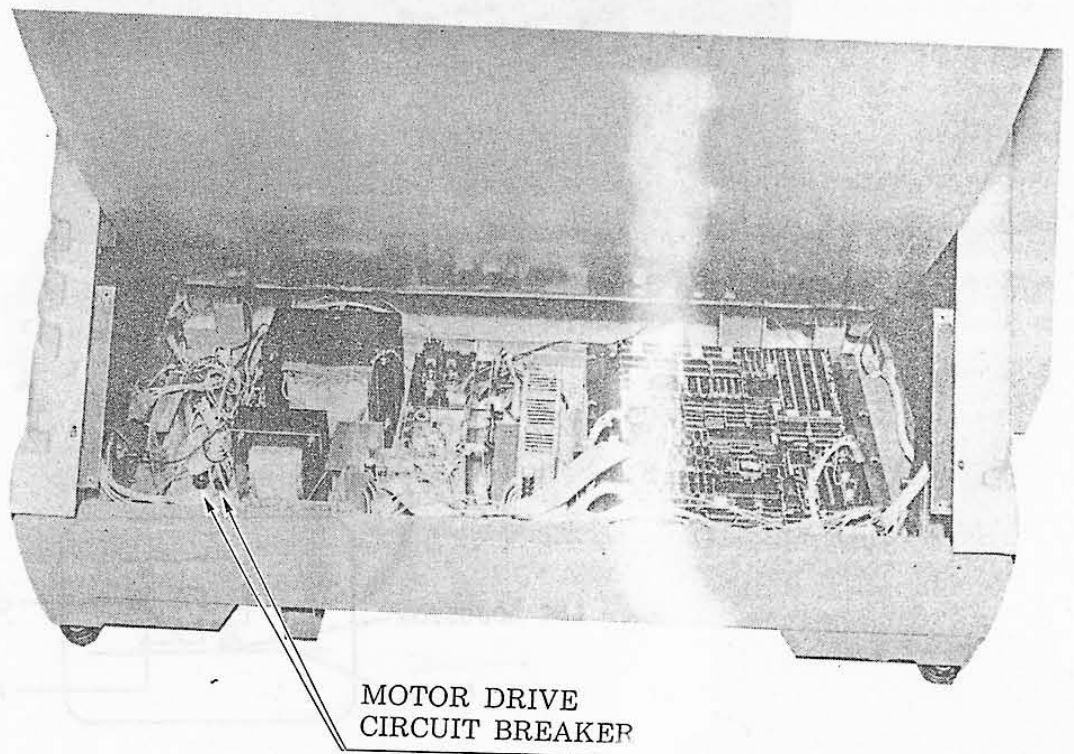
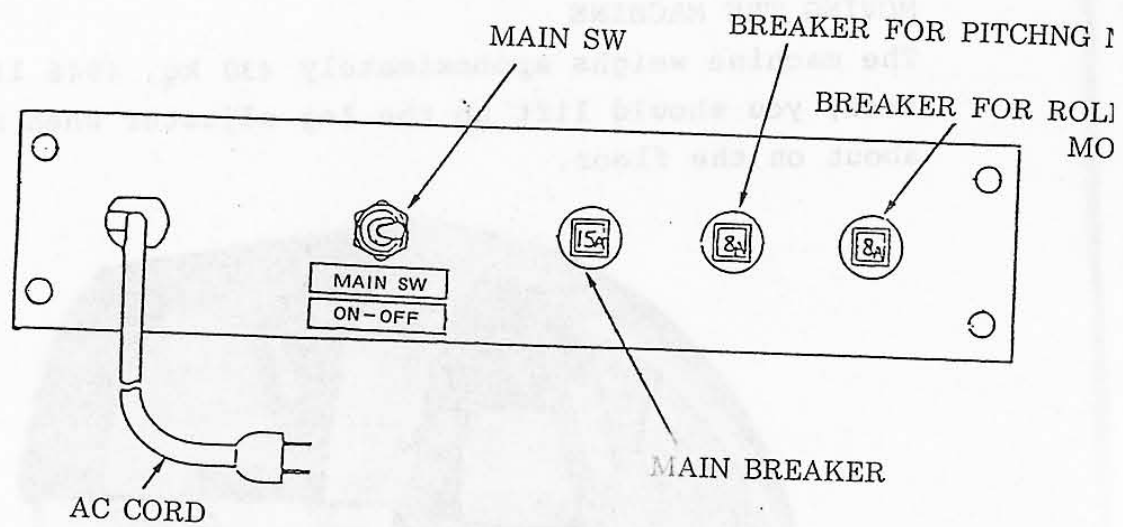

6. PRECAUTIONS FOR INSTALLING AND MOVING THE MACHINE

PRECAUTIONS FOR INSTALLATION

The machine is provided with 4 castors and 4 adjusters. When installing, make sure that the clearance between the floor and the castor is approximately 5 mm (if the clearance is insufficient, the machine will move and thus create a dangerous situation).

MOVING THE MACHINE

The machine weighs approximately 430 kg. (946 lbs.) and as such, you should lift up the leg adjuster when moving it about on the floor.

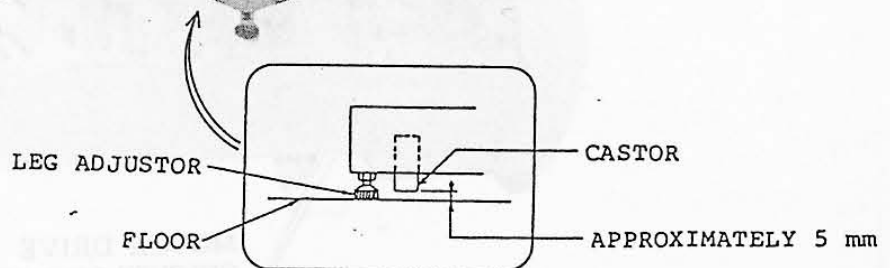

7. REMOVING THE COIN CHUTE TOWER

- ① Disconnect the 4 connectors inside the coin chute to the earth wire attached to the coin chute door.
- ② Take off the 4 (M8) bolts to separate the COIN CHUTE from the base.

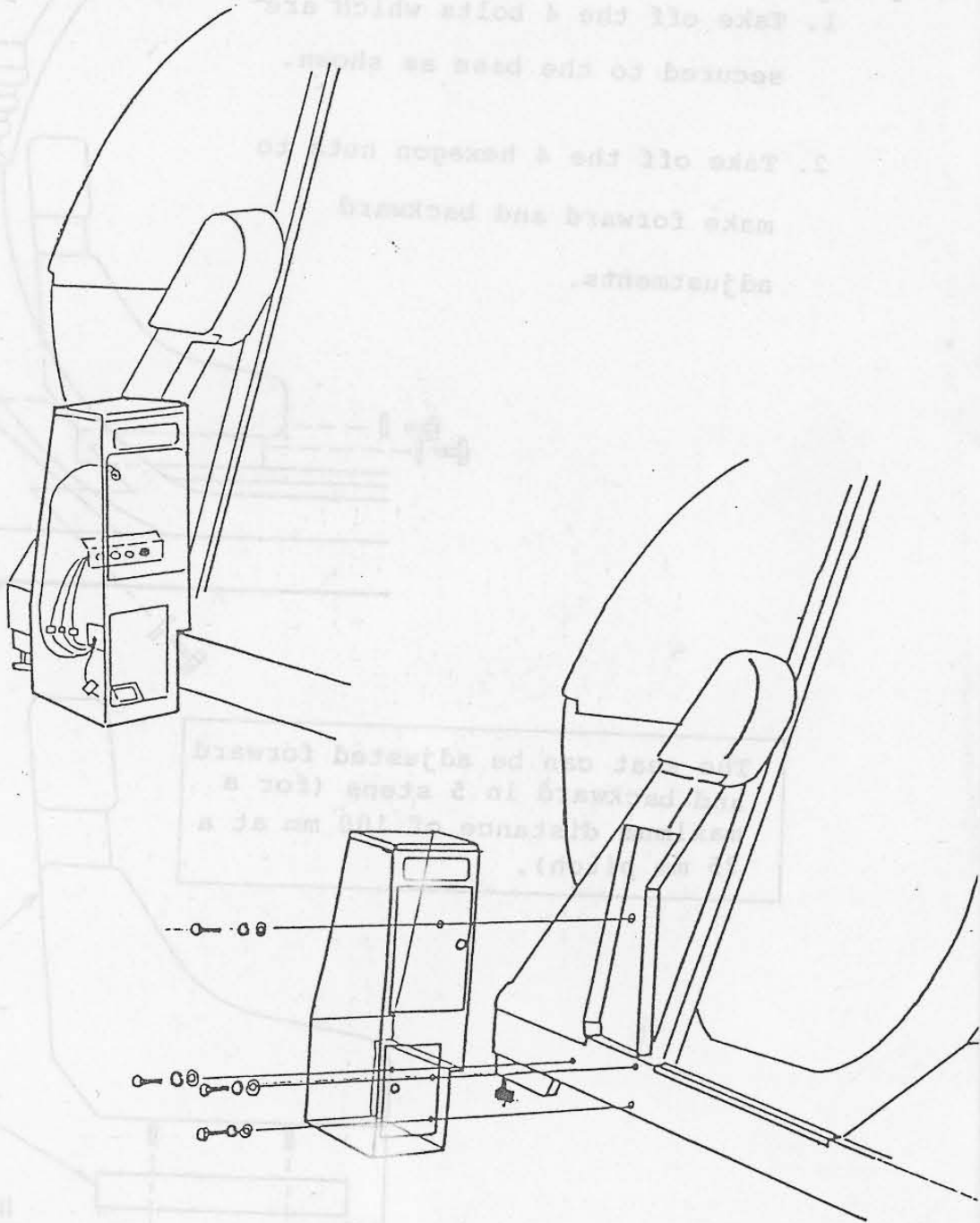

8. ADJUSTING THE SEAT POSITION

The machine's seat position is set at the time of shipment. To adjust, follow the procedure below:

PROCEDURE

1. Take off the 4 bolts which are secured to the base as shown.
2. Take off the 4 hexagon nuts to make forward and backward adjustments.

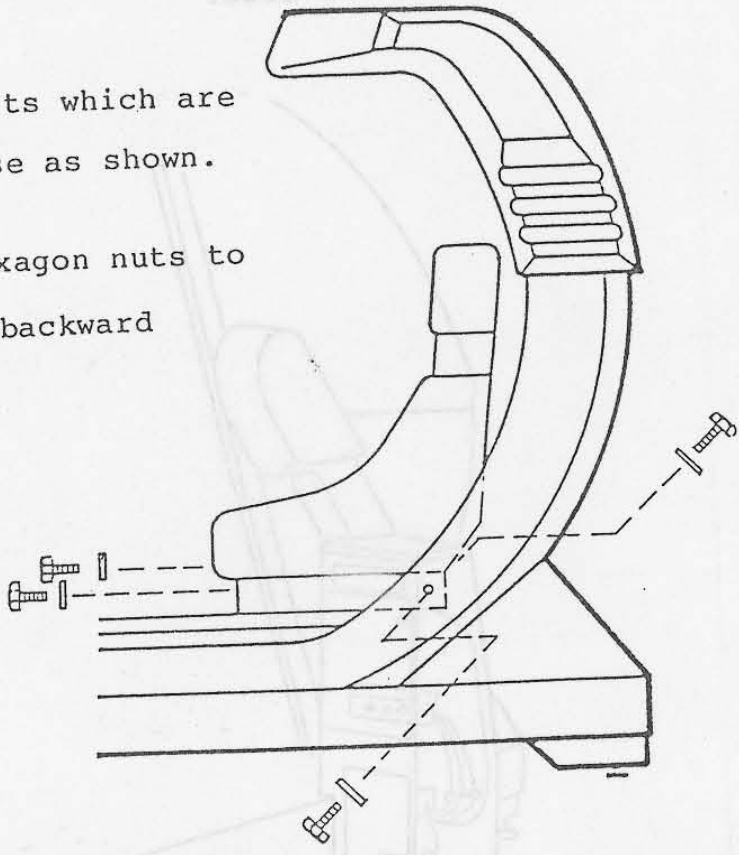

The seat can be adjusted forward and backward in 5 steps (for a maximum distance of 100 mm at a 25 mm pitch).

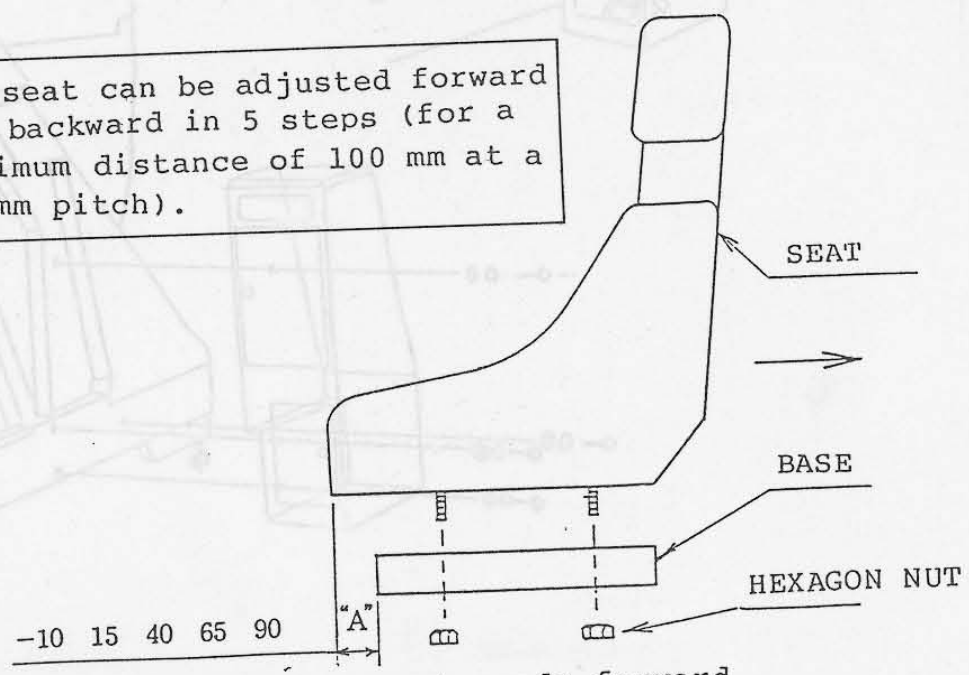

The seat adjustment can be made forward and backward in 5 steps.

9. REMOVING THE HANDLE UNIT

- ① Remove the front glass from the cabinet by taking off the (M5 x 25) tamperproof screws.
- ② Carefully pull out the handle unit towards you by taking the 4 front side and 4 bottom tamperproof screws which secure the handle unit.
- ③ Remove the handle unit from the cabinet by taking off the connectors (4P orange and 6P orange) and the earth wire.

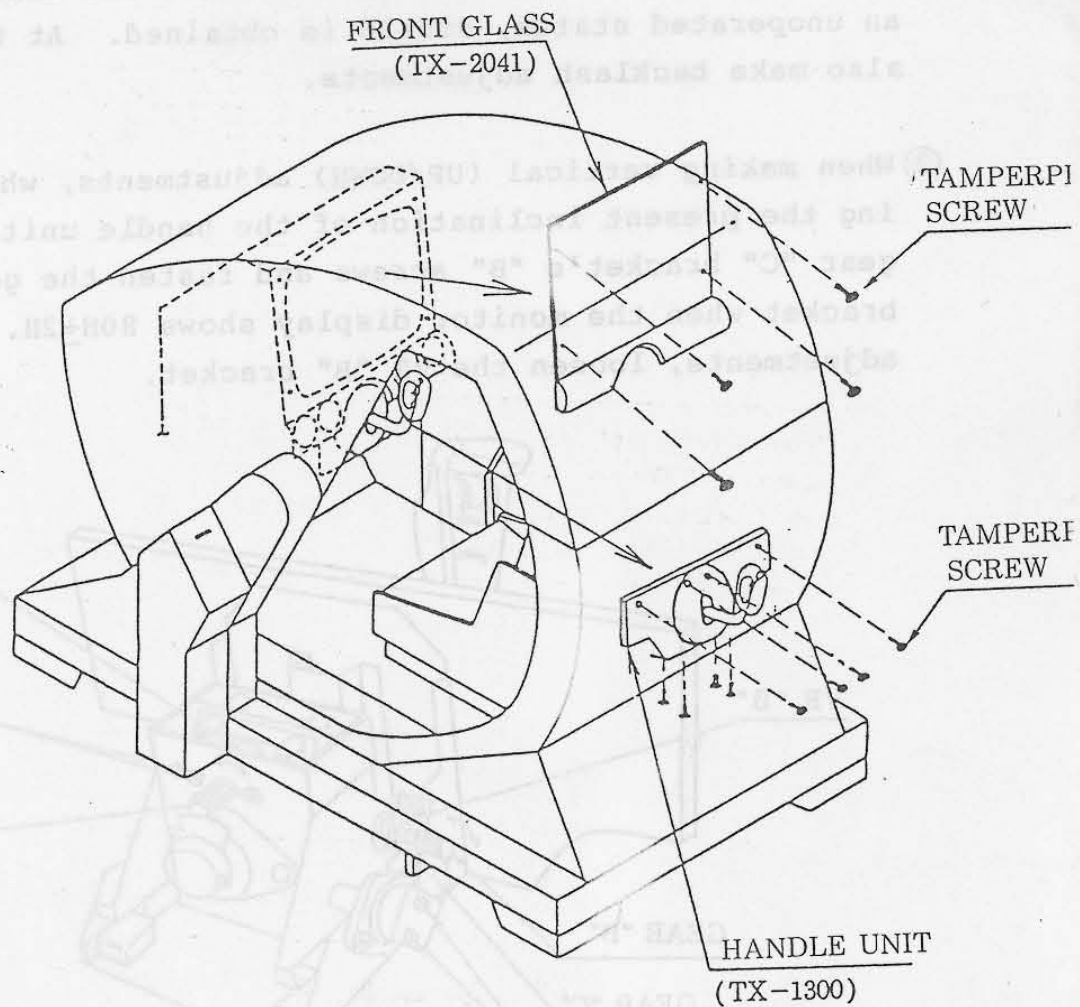

10. ADJUSTING THE HANDLE UNIT

In the test mode, cause the DIAGNOSTIC INPUT DISPLAY to appear on the screen (to select it, push the test switch and move the handle upward and downward).

DIAGNOSTIC INPUT TEST

COIN #1 OFF START OFF
COIN #2 OFF SERVICE OFF

VALCAN OFF
MISSILE OFF

STICK RIGHT LEFT 80H
STICK UP DOWN 80H
SPEED 80H

①

②

- ① To make VR adjustments in a horizontal direction (RIGHT/LEFT), release the VR "A" bracket's "A" screws and turn gear "A" in a manner so that when the handle grip is in an unoperated status, $80H+2H$ is obtained. At this time, also make backlash adjustments.
- ② When making vertical (UP/DOWN) adjustments, while maintaining the present inclination of the handle unit, unfasten the gear "C" bracket's "B" screws and fasten the gear "C" bracket when the monitor display shows $80H+2H$. For backlash adjustments, loosen the VR "B" bracket.

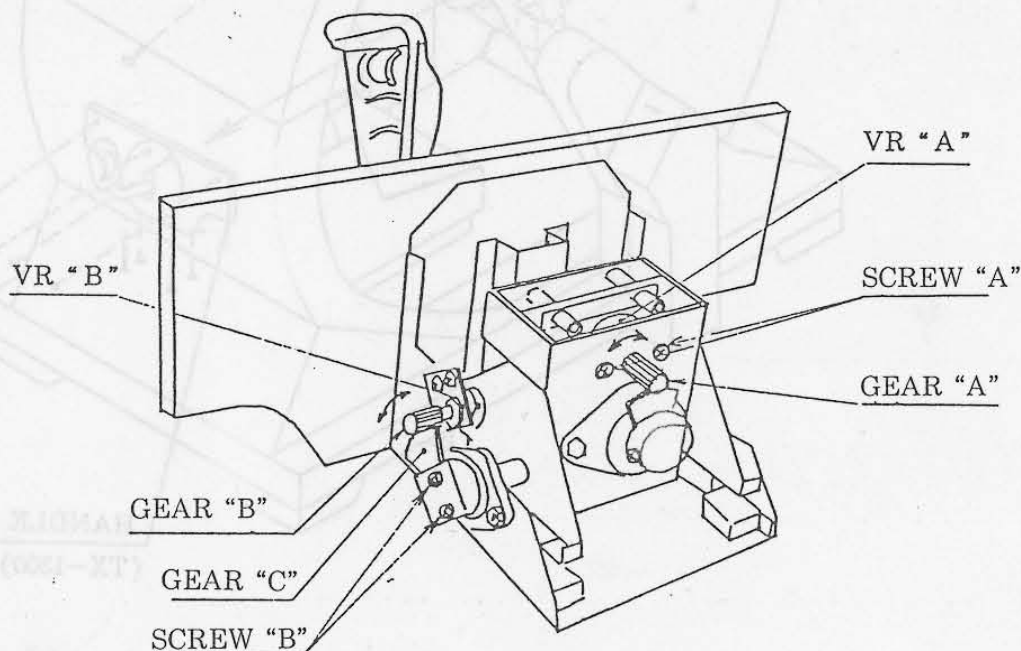

11. REMOVING THE LAMP BOX

- ① Loosen each of the 4 tamperproof screws (M4 x 30) located behind the seat approximately 5 mm.
- ② Push the tamperproof screws' heads with a screwdriver in manner so that the lamp box is pushed outside, and then completely take off the tamperproof screws.
- ③ Pull out the lamp box and disconnect the connectors to all the lamp box to be separated from the cabinet.
- ④ Remove the acryl board by taking off the CORNER UPPER and the CORNER LOWER.

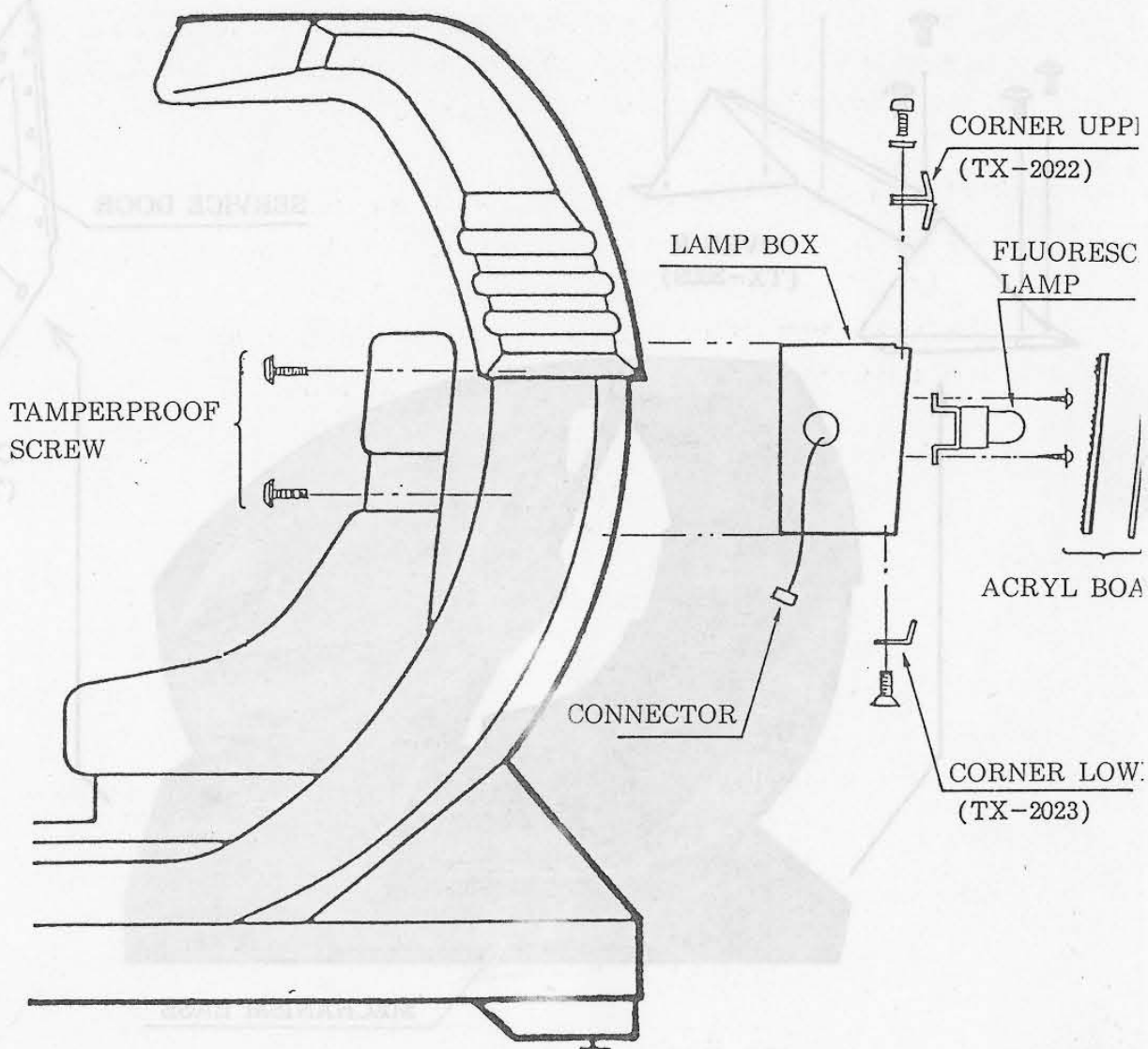

12. OPENING THE MECHANISM BASE

- o A motor, main IC board and the ASSY power supply are contained inside the mechanism base.
- o When servicing of the IC board and ASSY power supply is required, open COVER "F" by taking off the 4 (M5 x 10) tamperproof screws. The IC board can be replaced merely by opening the service door.
- o When motor mechanism service is necessary, open COVER "R" by taking off the 7 (M5 x 10) tamperproof screws.

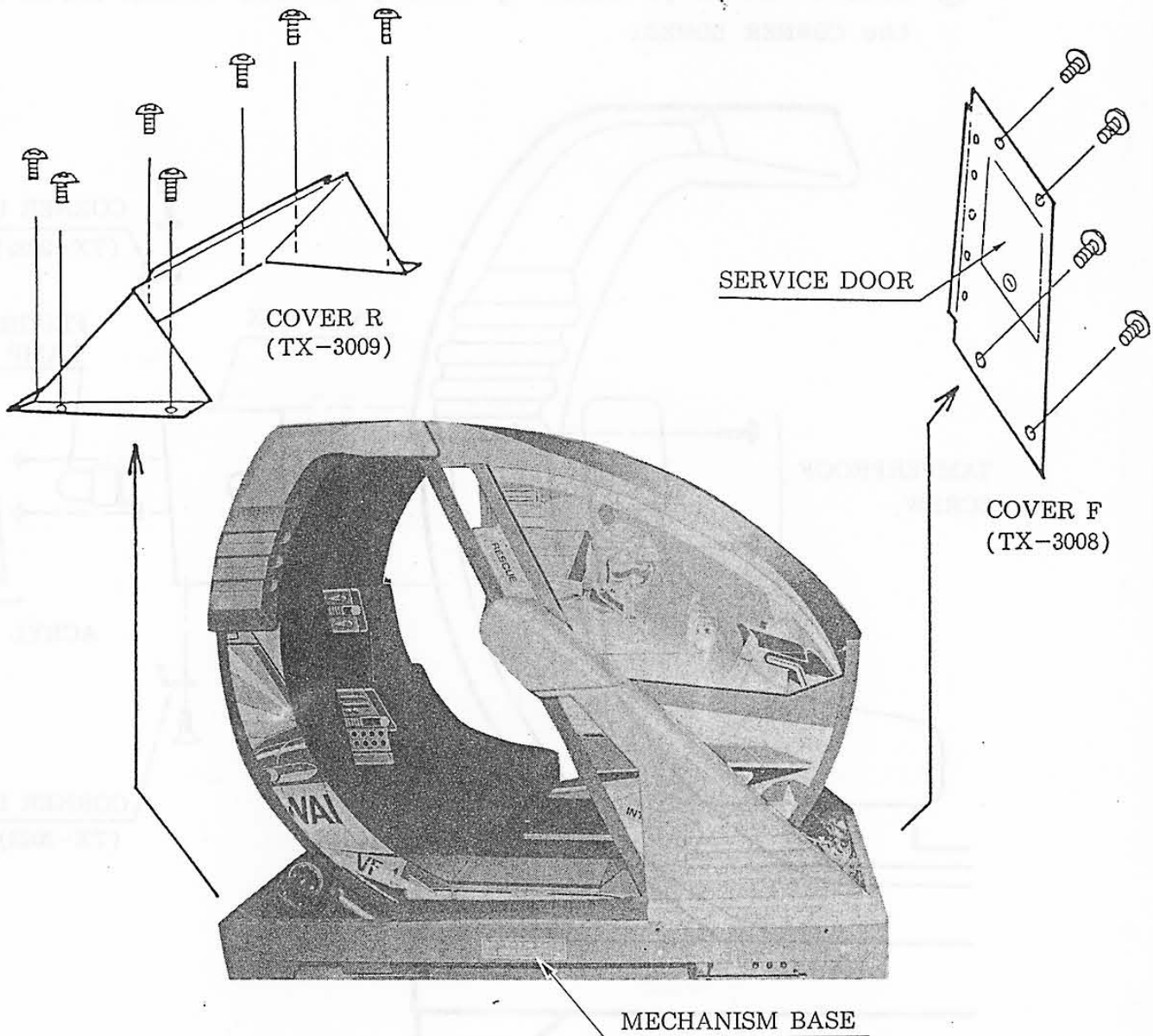

13. REMOVING THE ROLLING MOTOR UNIT

- ① Pull out the bottom board (TX-2014) towards you by taking off the 2 (M5 x 25) tamperproof screws.
- ② Disconnect the 2P connector, remove the bottom board, and you will see the rolling motor.

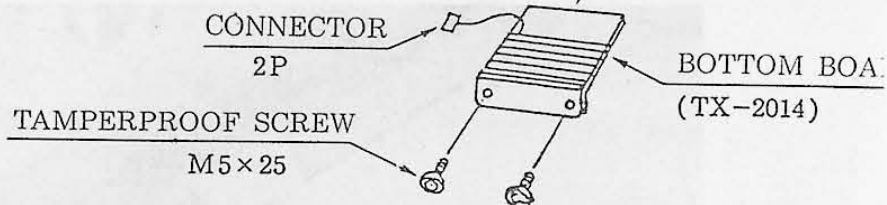
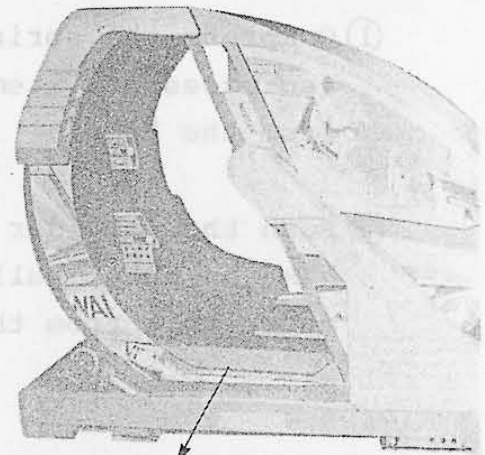

- ③ To remove the rolling motor unit, first compress the spring by fastening the hexagon bolt (an accessory item) to cause the tire to separate from the gondola.
- ④ Next, push the shoulder screws' heads, take off the hexagonal nuts, pull out the shoulder screws, and remove motor unit from the mechanism base.

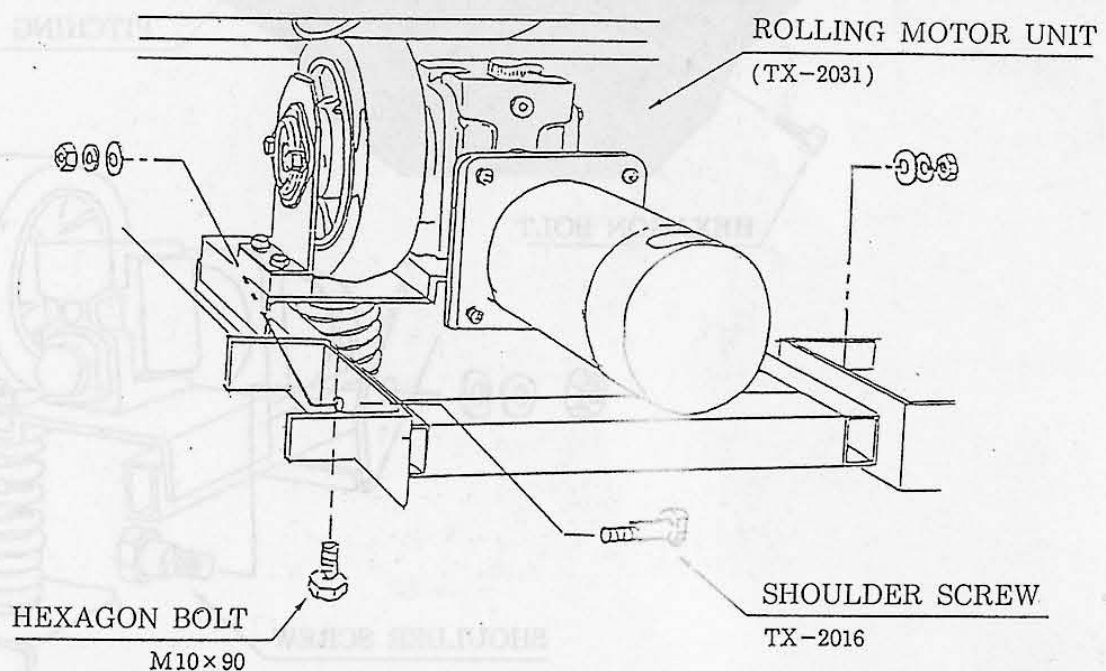

14. REMOVING THE PITCHING MOTOR UNIT

- ① Compress the spring by fastening the (M10 x 90) hexagon bolt (an accessory item) so as to allow the tire to be separated from the hoop.
- ② Push the shoulder screws' (TX-2016) heads, take off the hexagon nuts, pull out the shoulder screws, and remove the motor unit from the base.

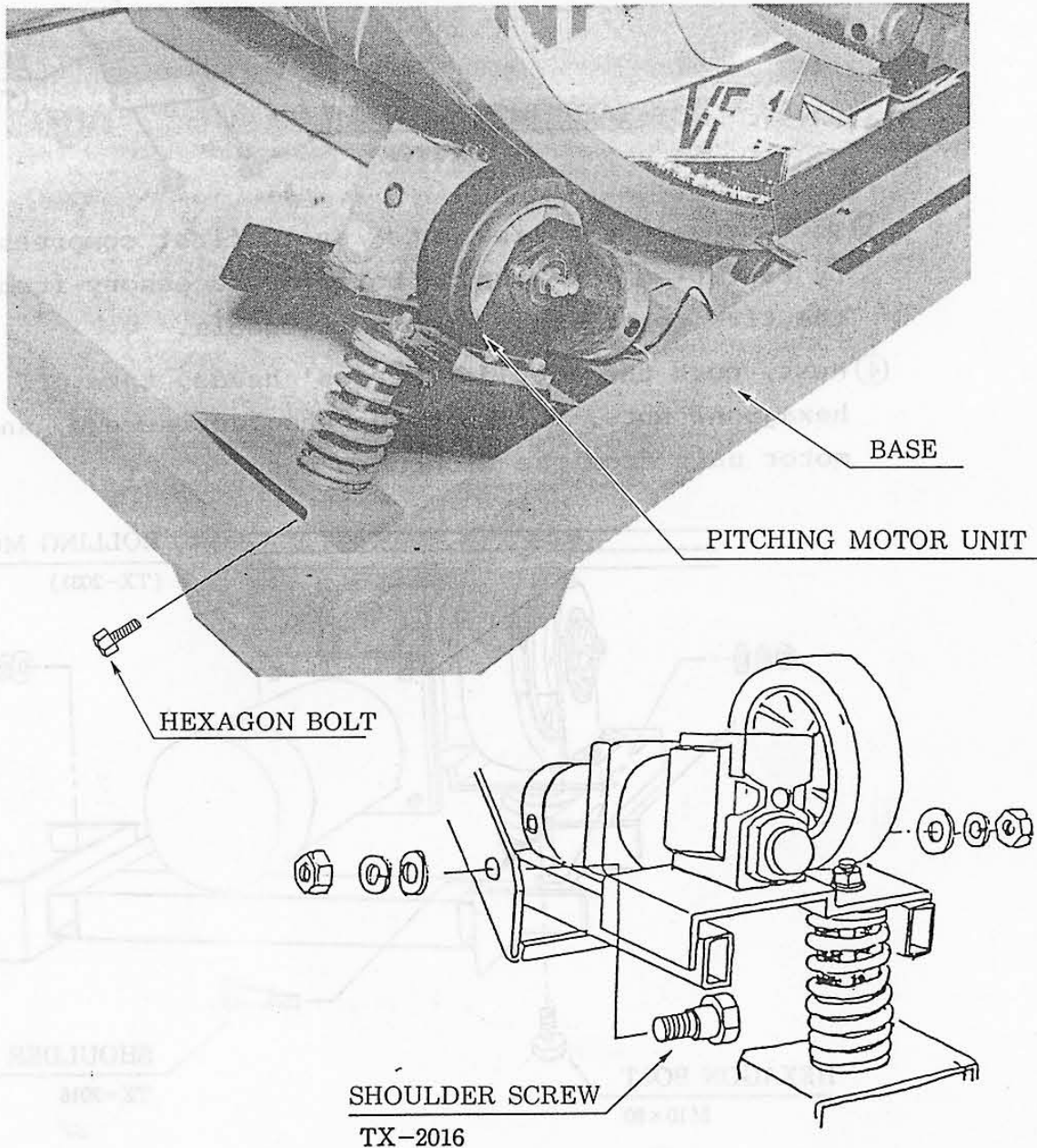

15. REPLACING THE MOTOR BRUSHES

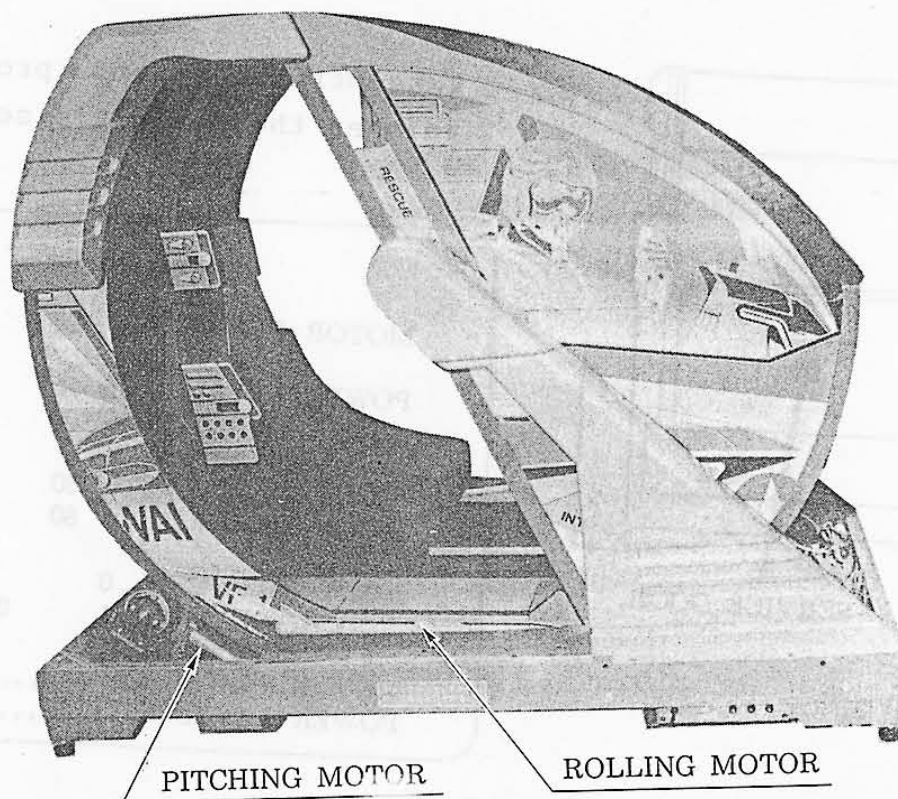

To replace the motor brushes, release the cap with a screwdriver, etc. and take out the brushes. Replacement once every 6 months is recommended. Make sure that both brushes simultaneously replaced.

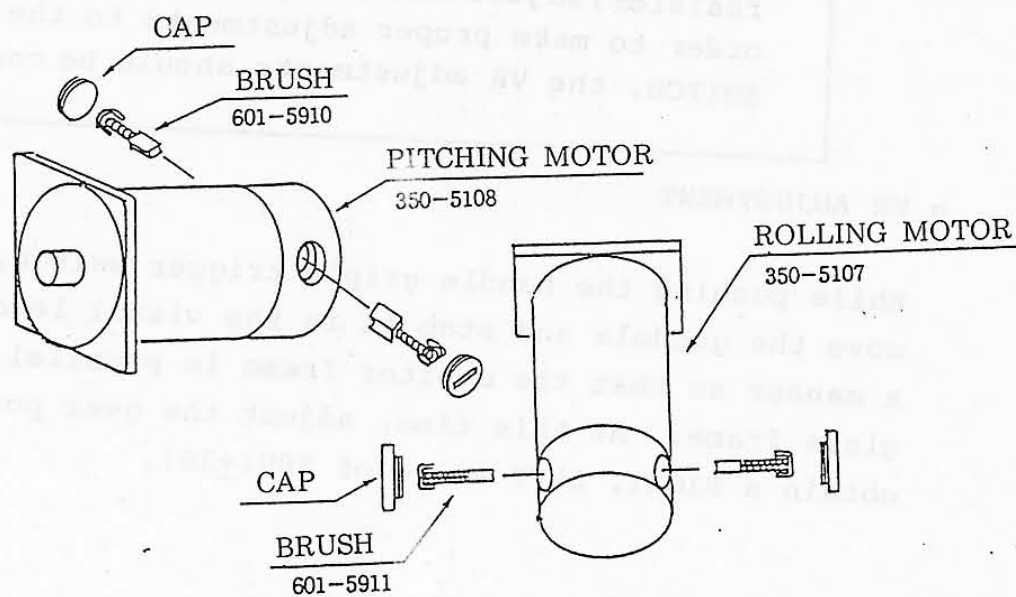

16. ROLLING ADJUSTMENTS

Take off the 4 tamperproof screws to open the cabinet's service door.

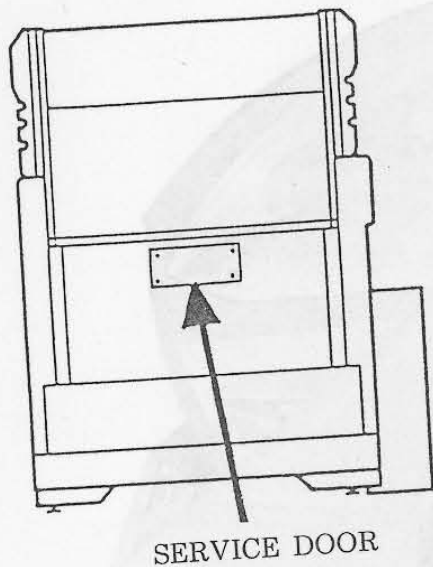

MOTOR TEST

MOTOR POWER OFF

POWER LEVEL 1 to 5 01

MOTOR POSITION

RIGHT, LEFT 80

UP, DOWN 80

LIMIT SW OFF,,0 0

ON,,1 0 0

0

MOTOR POWER ON,,,VALCAN SW

POWER LEVEL SELECT,,,START SW

Push the test SW to select the test mode and then move the handle upward and downward (UP/DOWN) to select MOTOR TEST, making sure that the screen display is as shown.

* When performing the LIMIT SW and VR (variable resistor) adjustments, adjust the VR first. (in order to make proper adjustments to the LIMIT SWITCH, the VR adjustments should be correct).

o VR ADJUSTMENT

While pushing the handle grip's trigger switch, horizontally move the gondola and stop it in the visual level position in a manner so that the monitor frame is parallel with the front glass frame. At this time, adjust the gear position so as to obtain a RIGHT, LEFT value of 80H(+2H).

LIMIT SW ADJUSTMENT

Loosen screw C and move the limit switch to make adjustment.

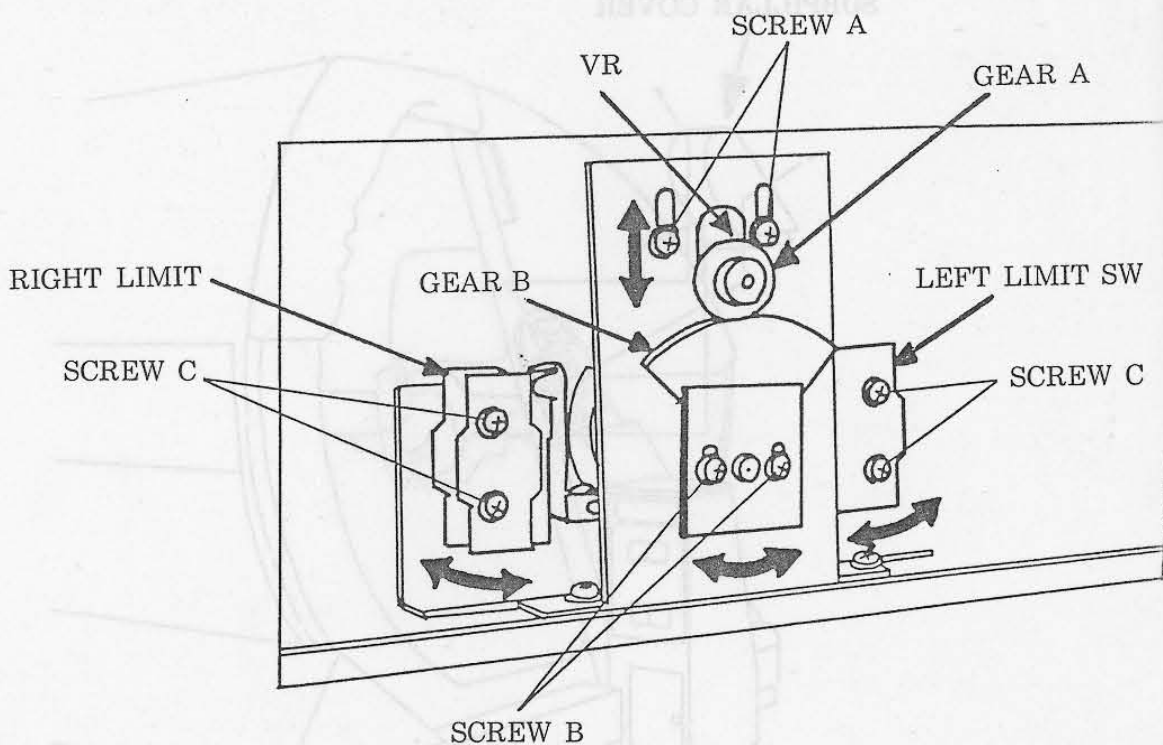

Push the trigger SW and while watching the screen, incline the handle grip to the left side. Check the RIGHT/LEFT VR value when the on-screen LIMIT SWITCH'S left-hand side "0" changes "1", and make LEFT LIMIT SW adjustments until the above VR value becomes $40H(+2H)$. Similarly, incline the handle grip to the right side, check the RIGHT/LEFT VR value when the on-screen LIMIT SWITCH'S right-hand side "0" changes to "1", and make RIGHT LIMIT SWITCH adjustments until the above VR value becomes $COH(+2H)$.

17. PITCHING ADJUSTMENTS

Take off 3 tamperproof screws to remove the subpillar cover.

SUBPILLAR COVER

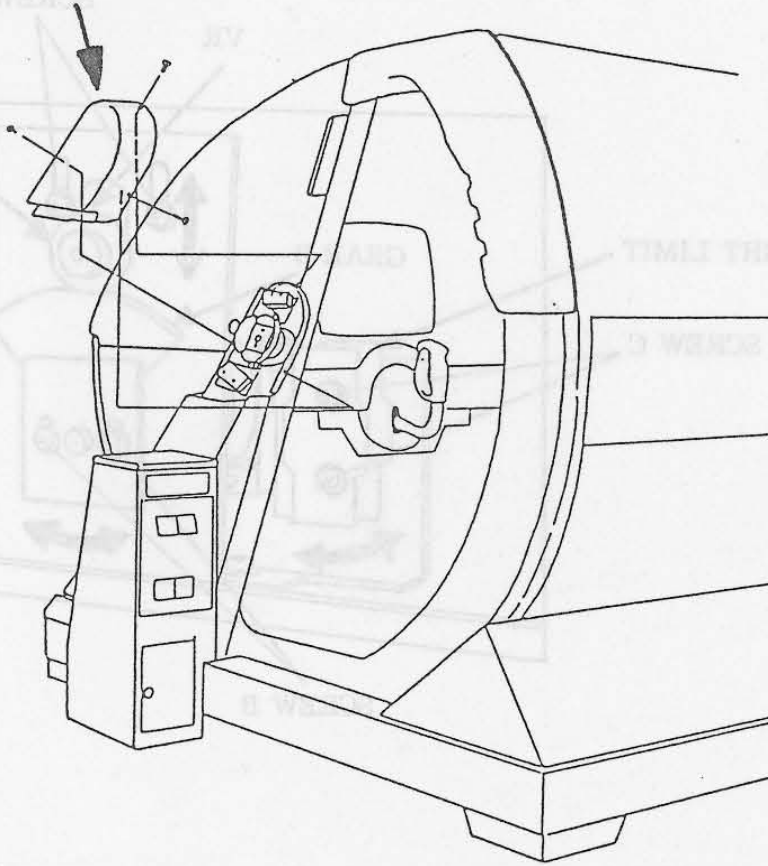

* When adjusting the LIMIT SW and VR, first make VR adjustments (in order to properly set the LIMIT SW, the VR adjustments must be made correctly).

Similarly as in the rolling adjustments, select MOTOR TEST on the screen.

o VR ADJUSTMENTS

Press the handle grip's trigger SW and maintain the cabinet in a level position (make sure that the missile illustration on the side of the cabinet is parallel with the base). At this time, ascertain that the on-screen UP/DOWN value is 80H(+2H)

First, loosen screw A and manually turn gear A to make adjustments of the backlash between gear A and gear B. Next, loosen screw B to turn the adjustment plate and make fine adjustments.

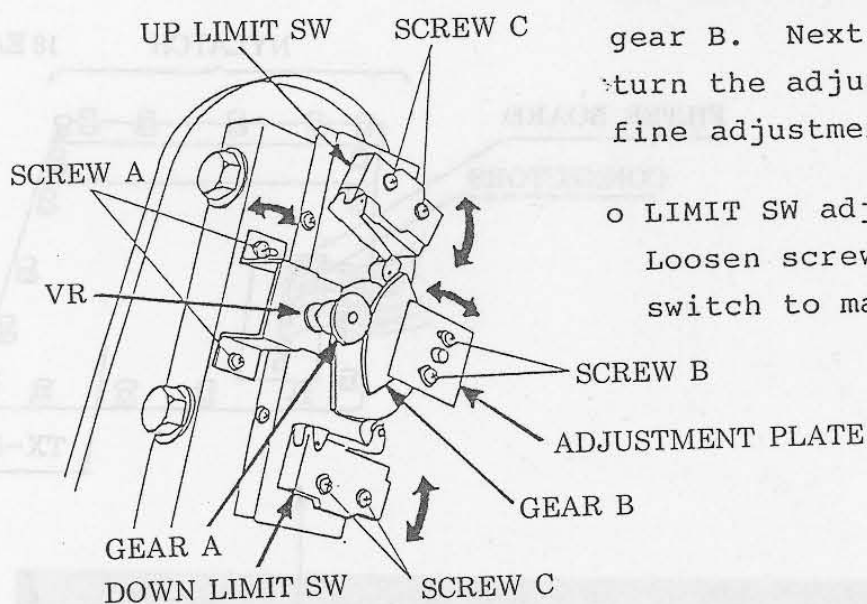

o LIMIT SW adjustments

Loosen screw C and move the limit switch to make adjustments.

Press the trigger switch and while watching the screen, pull handle grip towards you (at this time, if the cradle does not fully upward, then press the START SW and make MOTOR POWER LE adjustments), check for the UP/DOWN VR value when the on-screen LIMIT SWITCH'S upper "0" value changes to "1" and make UP LIMIT SW adjustment so that the above VR value becomes 20H(+2H). Similarly, push the handle grip upward and check the UP/DOWN value when the on-screen LIMIT SWITCH'S lower "0" value changes to "1", and make DOWN LIMIT SW adjustments in a manner so that the above VR value becomes E0H(+2).

18. REMOVING THE IC BOARD

1. Disconnect all of the 5 filter board (839-0097) connectors.
2. Pull the "NYLATCH" knobs upward (18 points).
3. Lift up the shield cover (TX-0004) side which is towards you, disconnect connectors (AMPJ latch 50P, 20P, FLAT 26P, JST 6P x 2 and 4P) which are inserted in the IC board, and then remove the shield cover.
4. The IC board is secured to the base with 4 wood screws. It can be removed by taking them off with a screwdriver.

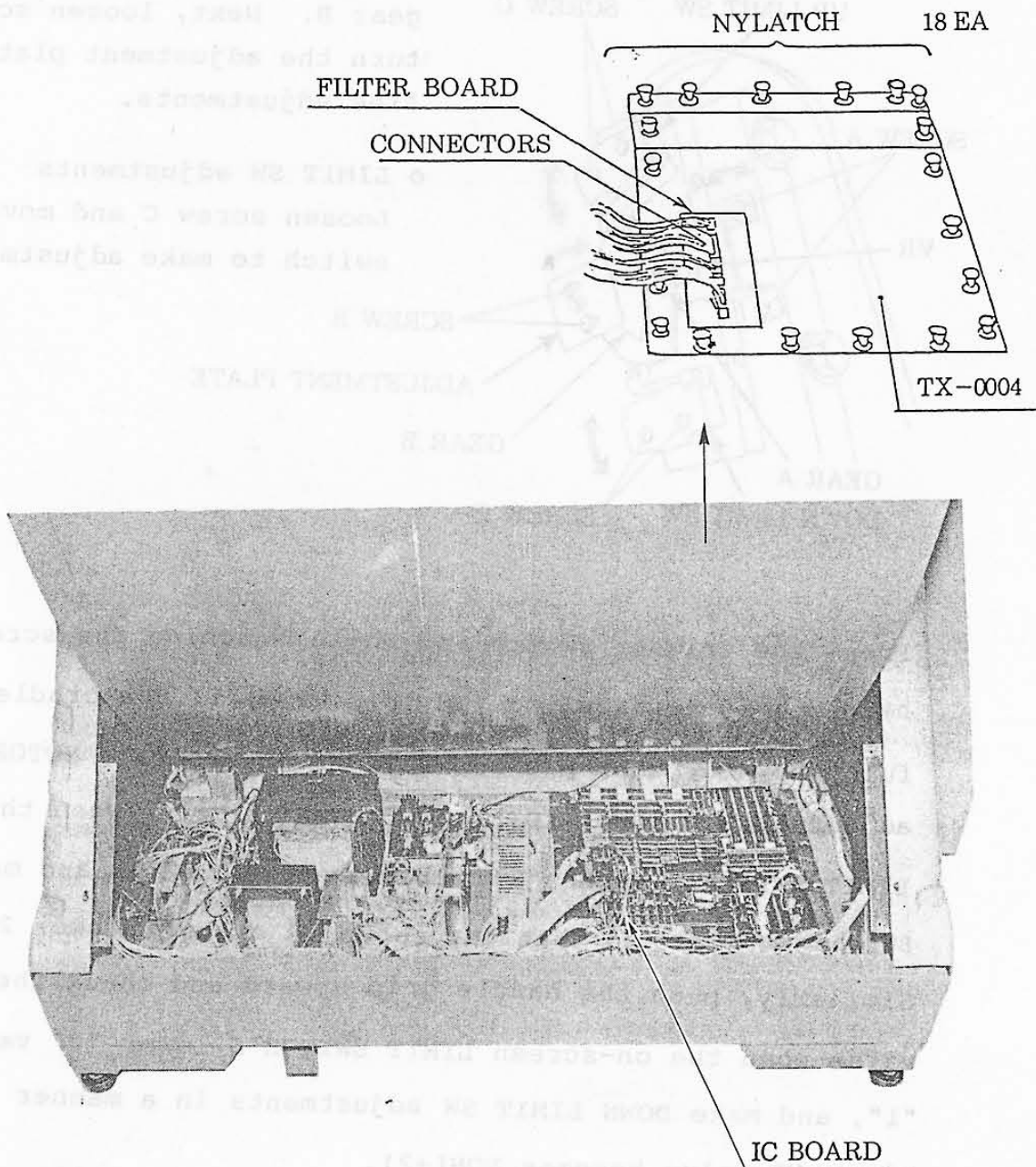

19. SERVICE SWITCH FUNCTIONS

The layout as shown below can be viewed by opening the coin chute door.

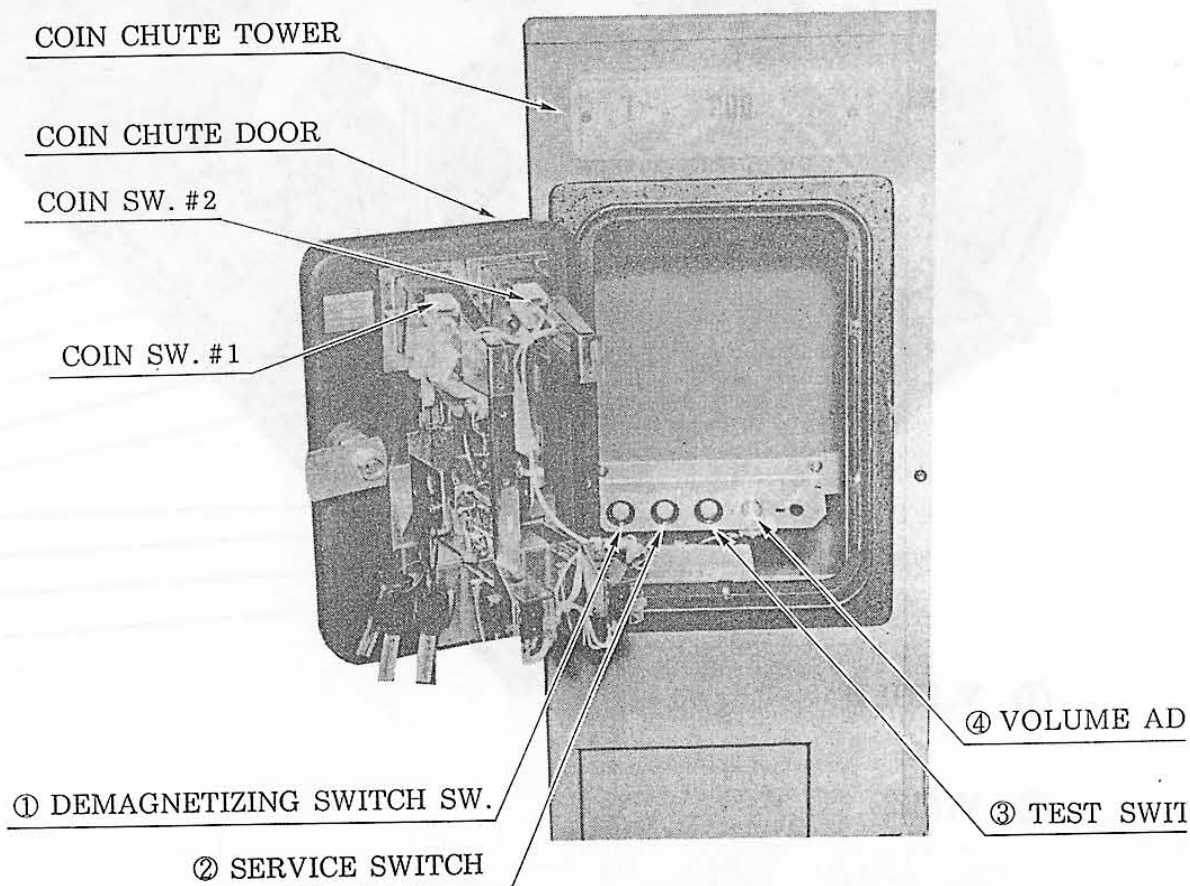

INSTRUCTIONS

- ① DEMAGNETIZING SWITCH Used for removing the on-sc color unevenness.
- ② SERVICE SWITCH Used for the purpose of servicing and increasing th credits without registering the meter (this allows you check the game).
- ③ TEST SWITCH For operating this switch, SELF-TESTING.
- ④ VOLUME ADJUSTMENT The volume of the speaker i the cowl can be adjusted.

20. 20 INCH MONITOR

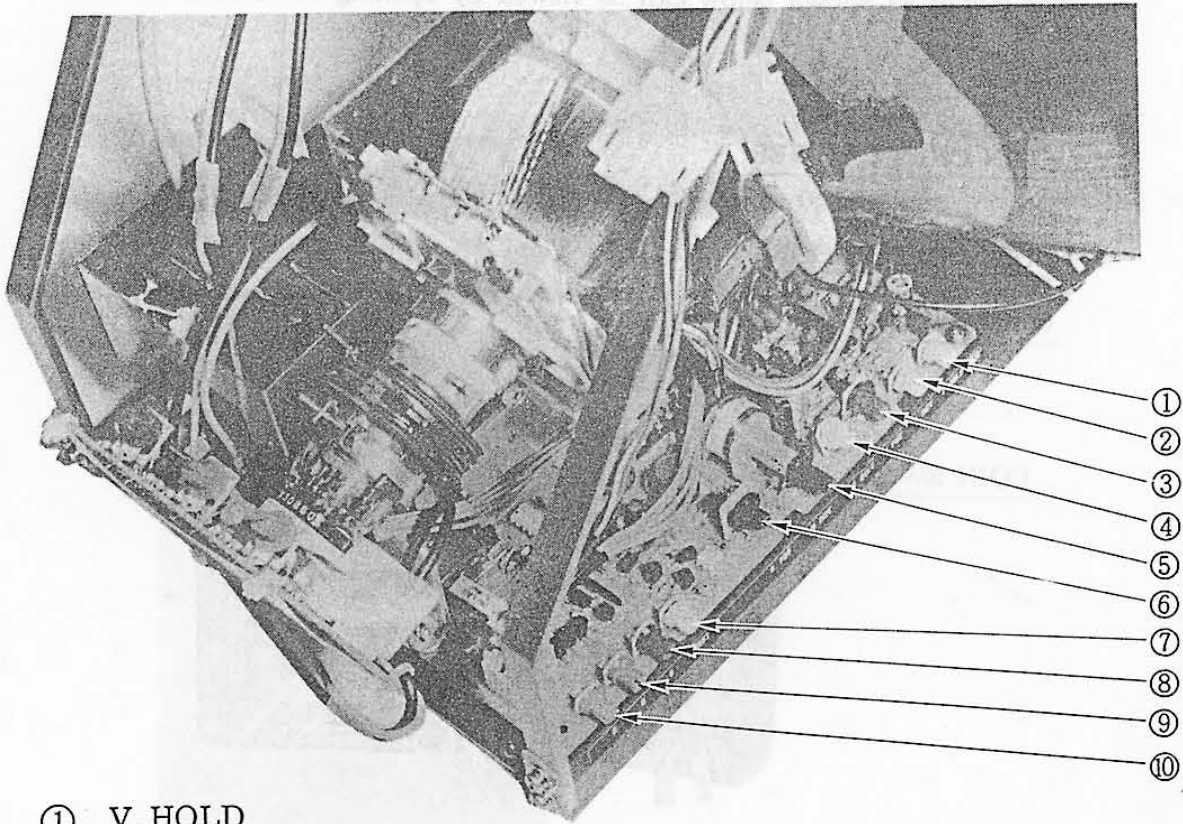

① V. HOLD

② V. SIZE

③ V. POSITION

④ H. HOLD

⑤ H. SIZE

⑥ H. POSITION

⑦ BRIGHT

⑧ B. GAIN

⑨ G. GAIN

⑩ R. GAIN

21. DIP SWITCH SETTING

COIN/CREDIT OPTION SWITCH SETTING

OPTION		DIP SWA							
		1	2	3	4	5	6	7	8
1 COIN	1 CREDIT	OFF	OFF	OFF	OFF	OFF	OFF	OFF	OFF
1 COIN	2 CREDITS	ON	OFF	OFF	OFF	ON	OFF	OFF	OFF
1 COIN	3 CREDITS	OFF	ON	OFF	OFF	ON	OFF	OFF	OFF
1 COIN	4 CREDITS	ON	ON	OFF	OFF	ON	OFF	OFF	OFF
1 COIN	5 CREDITS	OFF	OFF	ON	OFF	ON	OFF	ON	OFF
1 COIN	6 CREDITS	ON	OFF	ON	OFF	ON	OFF	ON	OFF
2 COINS	1 CREDIT	OFF	ON	ON	OFF	ON	ON	ON	OFF
3 COINS	1 CREDIT	ON	ON	ON	OFF	ON	ON	ON	OFF
4 COINS	1 CREDIT	OFF	OFF	OFF	ON	ON	OFF	OFF	ON
2 COINS	3 CREDITS	ON	OFF	OFF	ON	ON	OFF	OFF	ON
2 COINS	1 CREDIT	ON	ON	OFF	ON	ON	ON	OFF	ON
4 COINS	2 CREDITS	OFF	ON	OFF	ON	OFF	OFF	ON	ON
3 COINS	3 CREDITS	OFF	OFF	ON	ON	OFF	OFF	ON	ON
4 COINS	4 CREDITS								
5 COINS	6 CREDITS								
1 COIN	1 CREDIT	ON	OFF	ON	ON	ON	OFF	ON	ON
2 COINS	2 CREDITS								
3 COINS	3 CREDITS								
4 COINS	5 CREDITS								
1 COIN	1 CREDIT	OFF	ON	ON	ON	OFF	ON	ON	ON
2 COINS	3 CREDITS								
FREE PLAY		ON	ON	ON	ON	ON	ON	ON	ON
		COIN SW # 1				COIN SW # 2			

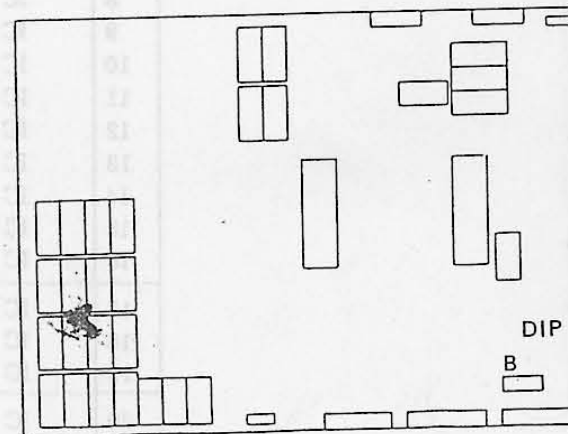
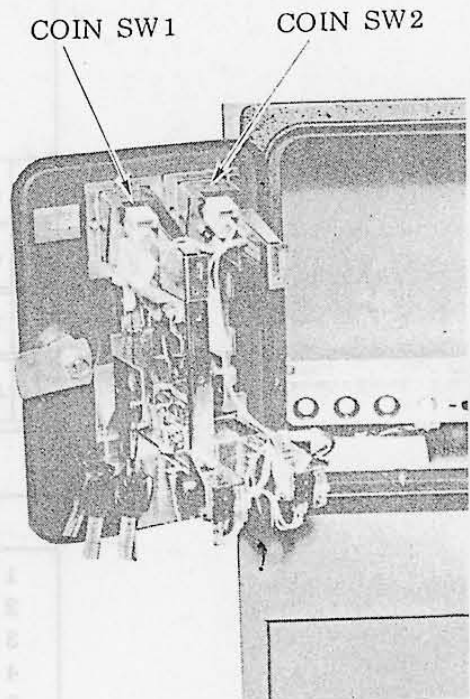

22. EPROM/MASK ROM LOCATIONS

GAME BD AFTER BURNER 834-6335

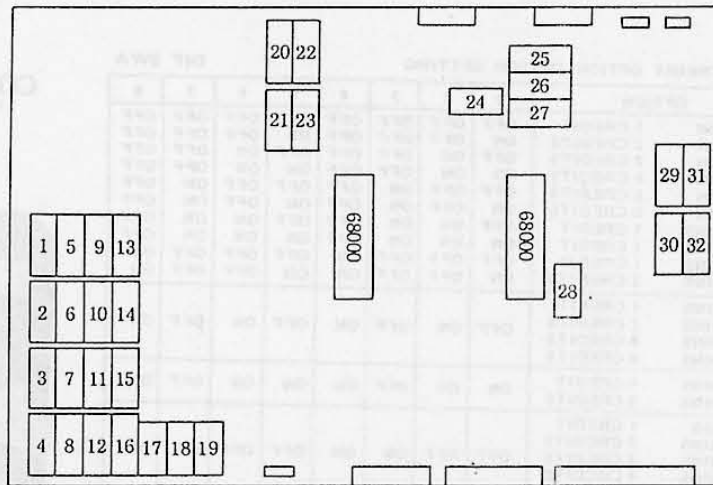

	IC LOCATION	NUMBER	MAIN WORK
1	IC 93	EPR-11098	OBJECT (CHARACTER & SCENE SCENERY)
2	IC 97	EPR-11099	
3	IC 101	EPR-11100	
4	IC 105	EPR-11101	
5	IC 92	EPR-11094	
6	IC 96	EPR-11095	
7	IC 100	EPR-11096	
8	IC 104	EPR-11097	
9	IC 91	MPR-10933	
10	IC 95	MPR-10935	
11	IC 99	MPR-10937	
12	IC 103	MPR-10939	
13	IC 90	MPR-10932	
14	IC 94	MPR-10934	
15	IC 98	MPR-10936	
16	IC 102	MPR-10938	
17	IC 154	EPR-11089	FIX SCROLL CHARACTER
18	IC 153	EPR-11088	
19	IC 152	EPR-11087	
20	IC 58	EPR-11092	MAIN PROGRAM
21	IC 63	EPR-11093	
22	IC 57	EPR-10950	
23	IC 62	EPR-10951	
24	IC 17	EPR-10923	SOUND PROGRAM
25	IC 11	MPR-10930	SOUND DATER
26	IC 12	MPR-10931	
27	IC 13	EPR-10929	
28	IC 40	EPR-10922	ROAD
29	IC 21	EPR-11090 EPR-11091	SUBPROGRAM
30	IC 30		
31	IC 20		
32	IC 29		

23. PARTS LIST

① TOP ASSY SEGA AFTER BURNER DELUXE TX-0000 (D-1/3)

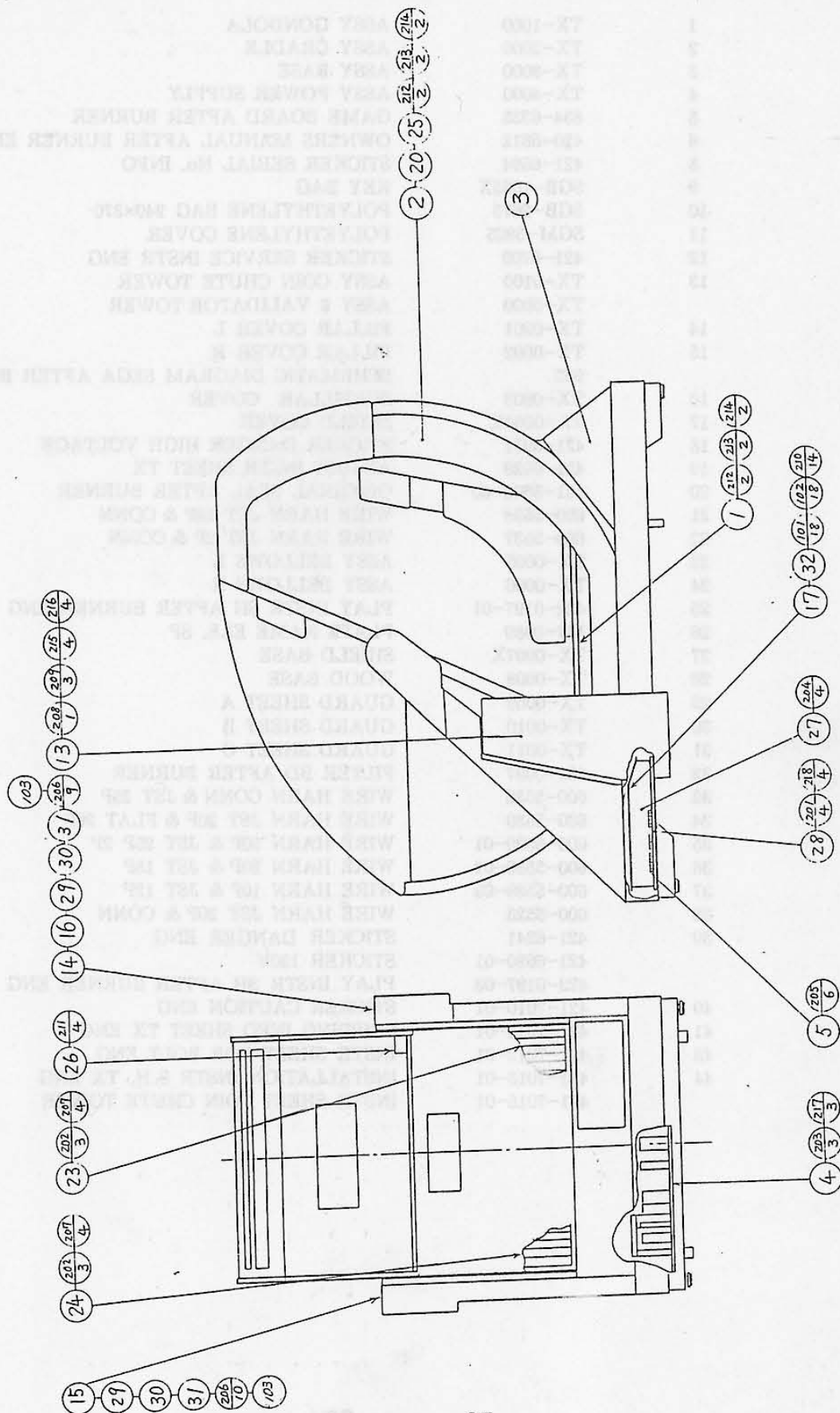

① TOP ASSY SEGA AFTER BURNER DELUXE TX-0000 (D-2/3)

ITEM NO.	PART NO.	DESCRIPTION
1	TX-1000	ASSY GONDOLA
2	TX-2000	ASSY CRADLE
3	TX-3000	ASSY BASE
4	TX-4000	ASSY POWER SUPPLY
5	834-6335	GAME BOARD AFTER BURNER
6	420-5812	OWNERS MANUAL AFTER BURNER ENG.
8	421-6594	STICKER SERIAL No. INFO
9	SGB-1035X	KEY BAG
10	SGB-2675	POLYETHYLENE BAG 240×370
11	SGM-3825	POLYETHYLENE COVER
12	421-6709	STICKER SERVICE INSTR ENG
13	TX-0100	ASSY COIN CHUTE TOWER
	TX-5000	ASSY \$ VALIDATOR TOWER
14	TX-0001	PILLAR COVER L
15	TX-0002	PILLAR COVER R
	953	SCHEMATIC DIAGRAM SEGA AFTER BURNER
16	TX-0003	SUBPILLAR COVER
17	TX-0004X	SHIELD COVER
18	421-6671	STICKER DANGER HIGH VOLTAGE
19	421-6929	ADJUST INSTR SHEET TX
20	421-5800-60	ORIGINAL SEAL AFTER BURNER
21	600-5538	WIRE HARN JST 18P & CONN
22	600-5537	WIRE HARN JST 2P & CONN
23	TX-0005	ASSY BELLOWS L
24	TX-0006	ASSY BELLOWS R
25	422-0197-01	PLAY INSTR SH AFTER BURNER ENG
26	117-0089	PLATE NAME ELE. SP
27	TX-0007X	SHIELD BASE
28	TX-0008	WOOD BASE
29	TX-0009	GUARD SHEET A
30	TX-0010	GUARD SHEET B
31	TX-0011	GUARD SHEET C
32	839-0097	FILTER BD AFTER BURNER
33	600-5536	WIRE HARN CONN & JST 25P
34	600-5539	WIRE HARN JST 20P & FLAT 26P
35	600-5539-01	WIRE HARN 50P & JST 25P 2P
36	600-5539-02	WIRE HARN 20P & JST 18P
37	600-5539-03	WIRE HARN 10P & JST 12P
38	600-5525	WIRE HARN JST 20P & CONN
39	421-6241	STICKER DANGER ENG
	421-6690-01	STICKER 120V
	422-0197-03	PLAY INSTR SH AFTER BURNER ENG
40	421-7010-01	STICKER CAUTION ENG
41	421-7011-01	SHIPPING INFO SHEET TX ENG
43	421-7012-01	INSTR SHEET FOR BOLT ENG
44	421-7013-01	INSTALLATION INSTR S.H. TX ENG
	421-7015-01	INSTR SHEET COIN CHUTE TOWER

① TOP ASSY SEGA AFTER BURNER DELUXE TX-0000 (D-3/3)

ITEM NO.	PART NO.	DESCRIPTION
101	280-5079	NYLATCH GROMMET
102	280-5080	NYLATCH PLUNGER
103	090-0007	DOUBLE FACE TAPE 20mm×50m/ ROLL
201	000-0516	M SCR PH M5×16
202	000-0516-FS	M SCR PH W/FS M5×16
203	000-0525	M SCR PH M5×25
204	005-3510	W SCR RH 3.5×20
205	005-3516-F	W SCR RH W/F 3.5×16
206	008-0410	TMP PRF SCR TH M4×10
207	039-0025	HEX BLT BLK M5×25
208	030-0850	HEX BLT M8×60
209	030-0860	HEX BLT M8×60
210	010-0308-F	S-TITE SCR PH W/F M3×8
211	046-0001	SCR NAIL THH STNLS 1.5×16
212	059-0022	HEX NUT M16
213	069-0060	SPR WSHR M16
214	069-0042	FLT WSHR M16
215	060-0008	FLT WSHR M8
216	061-0008	SPR WSHR M8
217	069-0001	FLT WSHR 5.5-20×1.6
218	060-0005	FLT WSHR M5
219	069-0017	FLT WSHR BLK M5

DESCRIPTION	PART NO.	QTY
WELD BRACKET	TX-001	1
GUIDE PLATE	TX-002	2
SLIDE BASE	TX-003	2
COVER PLATE INSIDE	TX-004	1
OUTSIDE BRACKET	TX-005	2
COVER PLATE OUTSIDE	TX-006	1
SHOULDER SCREW	TX-007	1
BELLOWS TIE	TX-008	1
M SCR PH M5×16	000-0516	100
U-NUT M4	000-050	200
U-NUT M5	000-050	200

② ASSY BELLOWS L TX-0005

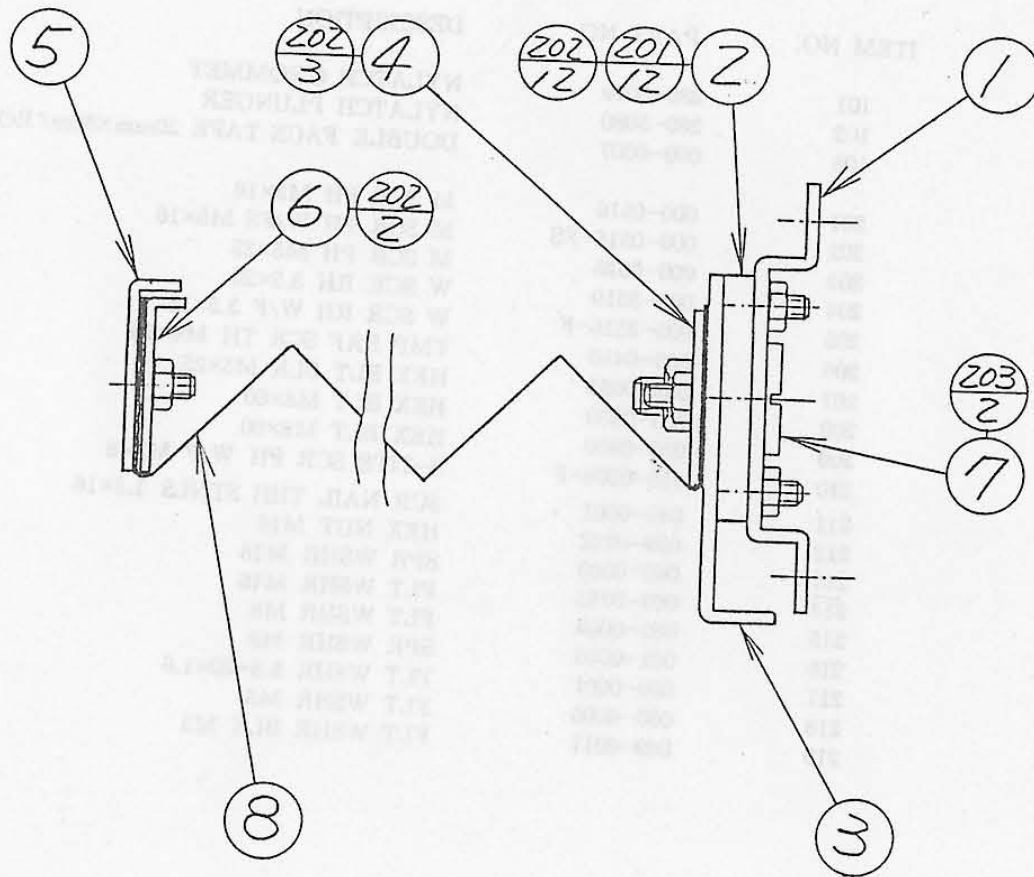

ITEM NO.	PART NO.	DESCRIPTION
1	TX-0012	INSIDE BRACKET
2	TX-0013	GUIDE PLATE
3	TX-0014	SLIDE BASE
4	TX-0015	COVER PLATE INSIDE
5	TX-0016	OUTSIDE BRACKET
6	TX-0017	COVER PLATE OUTSIDE
7	TX-0018	SHOULDER SCREW
8	TX-0020	BELLOWS LEFT
201	000-0414	M SCR FH M4×14
202	054-0004	U-NUT M4
203	054-0006	U-NUT M6

③ ASSY BELLOWS R TX-0006

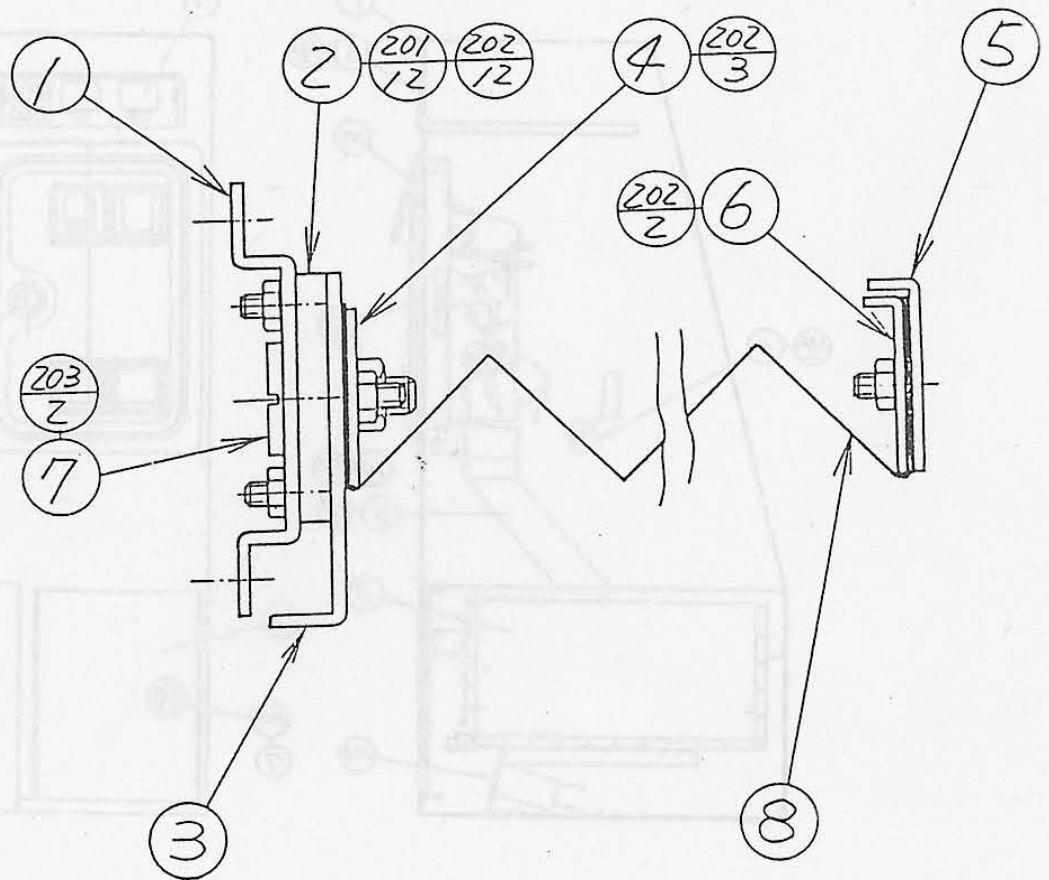

ITEM NO.	PART NO.	DESCRIPTION
1	TX-0012	INSIDE BRACKET
2	TX-0013	GUIDE PLATE
3	TX-0014	SLIDE BASE
4	TX-0015	COVER PLATE INSIDE
5	TX-0016	OUTSIDE BRACKET
6	TX-0017	COVER PLATE OUTSIDE
7	TX-0018	SHOULDER SCREW
8	TX-0019	BELLOWS RIGHT
201	000-0414	M SCR FH M4×14
202	054-0004	U-NUT M4
203	054-6666	U-NUT M6

④ ASSY COIN CHUTE TOWER TX-0100

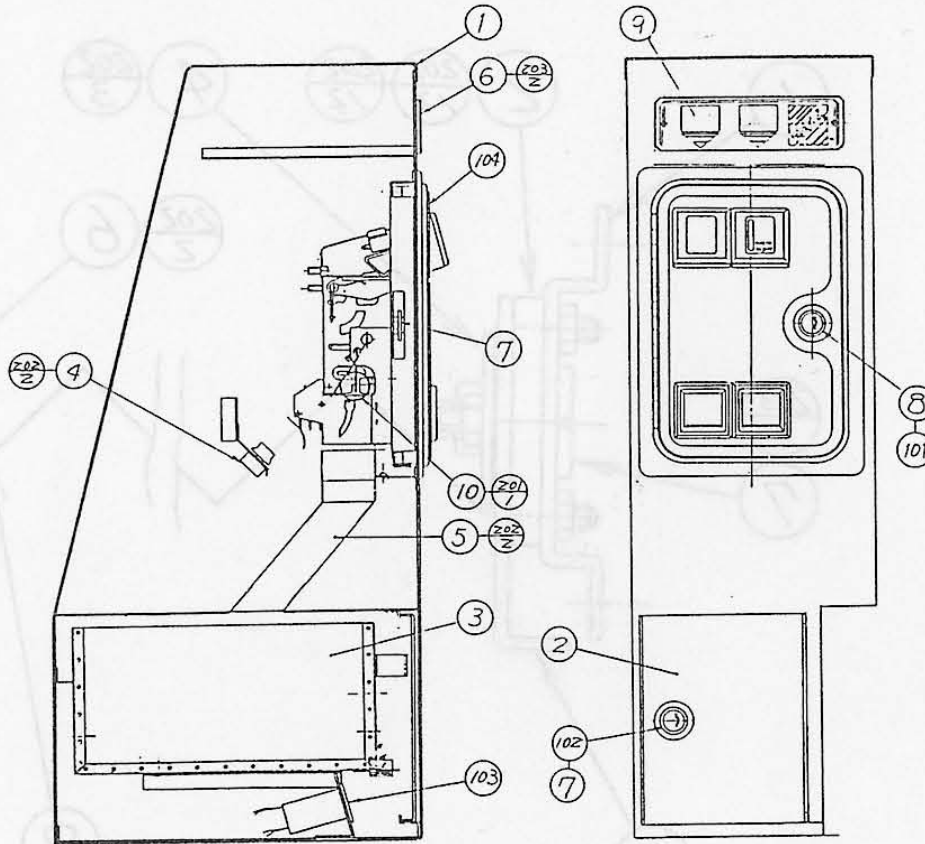

ITEM NO.	PART NO.	DESCRIPTION
1	TX-0101X	COIN CHUTE TOWER
2	TX-0102	DOOR, CASHBOX
3	TX-0103	CASHBOX
4	TX-0104	SW. UNIT
5	KR-1402	COIN CHUTE BK
6	KR-1403	DENOMINATION PLATE
7	DP-1167	TNG LKG
8	HN-1050	SPACER RING
9	MX-1103	DENOMI SH
10	109-0045	HOLDER KEY TURBO UPR
101	220-5044-01	MAGNETIC LOCK MASTER W/O KEY
102	220-5046	MAGNETIC LOCK W/KEY
103	220-5064	MAG CNTR 6DIG DC 5V
104	220-5174	ASSY COIN CHUTE DOOR
105	280-5008	CORD CLAMP ϕ 15
106	280-0425	CORD CLAMP ϕ 10
201	000-0306-FS	M. SCR. P · H W/SF M3×6
202	010-0406-F	S-TITE SCR W/F M4×6
203	012-0410	TMP PRF SCR T · H M4×10

⑤ ASSY BILL VALIDATOR TOWER TX-5000 (D-1/2)

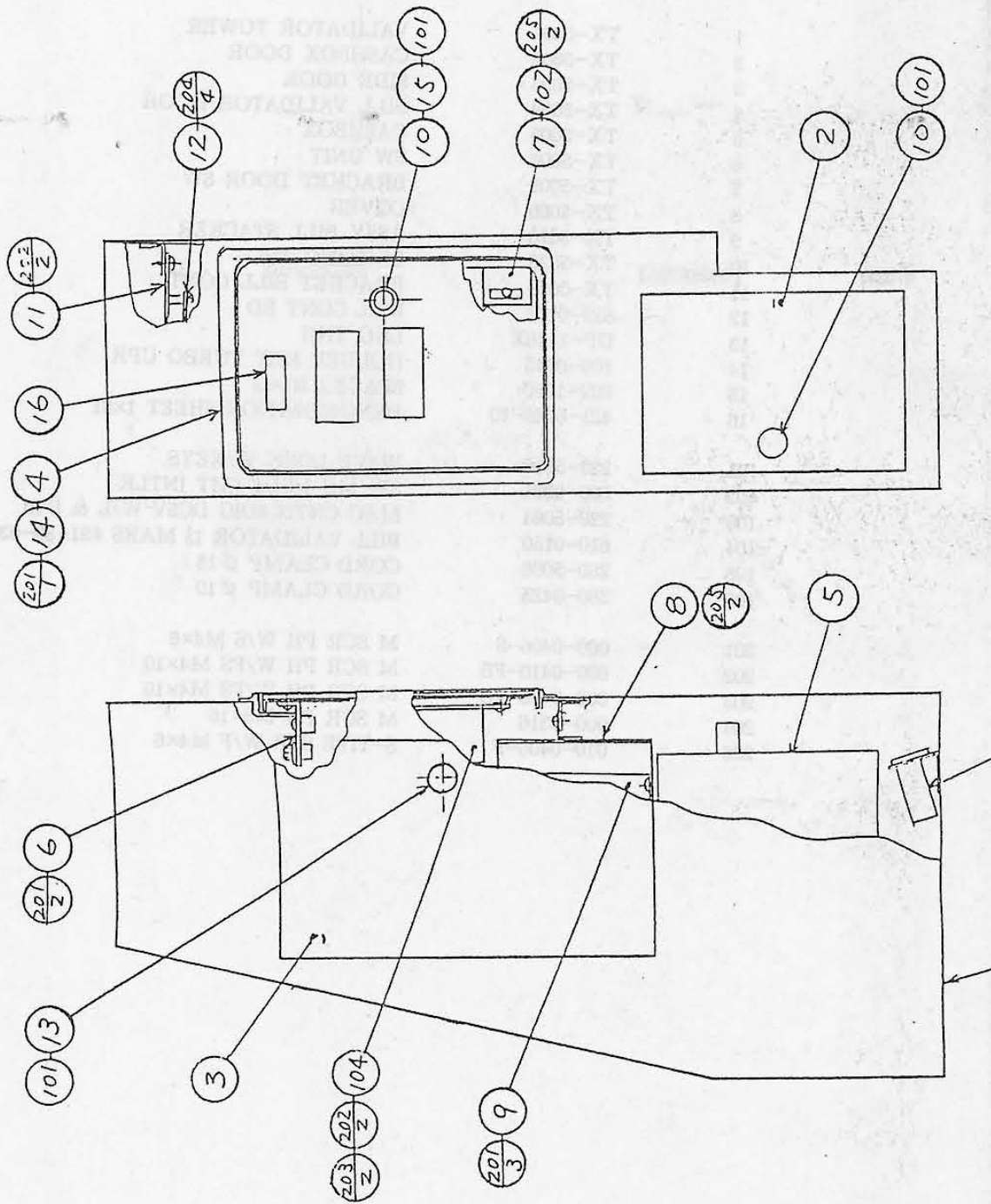

⑤ ASSY BILL VALIDATOR TOWER TX-5000 (D-2/2)

ITEM NO.	PART NO.	DESCRIPTION
1	TX-5001	VALIDATOR TOWER
2	TX-5002	CASHBOX DOOR
3	TX-5003	SIDE DOOR
4	TX-5004	BILL VALIDATOR DOOR
5	TX-5005	CASHBOX
6	TX-5006	SW UNIT
7	TX-5008	BRACKET DOOR SW
8	TX-5009	COVER
9	TX-5010	ASSY BILL STACKER
10	TX-5028	LOCKING TNG
11	TX-5029	BRACKET BILL CONT
12	839-0104	BILL CONT BD
13	DP-1148X	LKG TNG
14	109-0045	HOLDER KEY TURBO UPR
15	HN-1050	SPACER RING
16	421-6186-15	DENOMINATION SHEET 1x\$1
101	220-5118	WAVE LOCK W/KEYS
102	509-0095	SW MC DPDT CHT INTLK
103	220-5064	MAG CNTR 6DIG DC5V W/L & D10
104	610-0150	BILL VALIDATOR 1\$ MARS #91-30-032-4
105	280-5008	CORD CLAMP ϕ 15
106	280-0425	CORD CLAMP ϕ 10
201	000-0406-S	M SCR PH W/S M4x6
202	000-0410-FS	M SCR PH W/FS M4x10
203	000-0416-FS	M SCR PH W/FS M4x16
204	000-0316	M SCR PH M3x16
205	010-0406-F	S-TITE SCR W/F M4x6

⑥ SW UNIT TX-0104

0001-XT AJODN09 Y28A ⑥

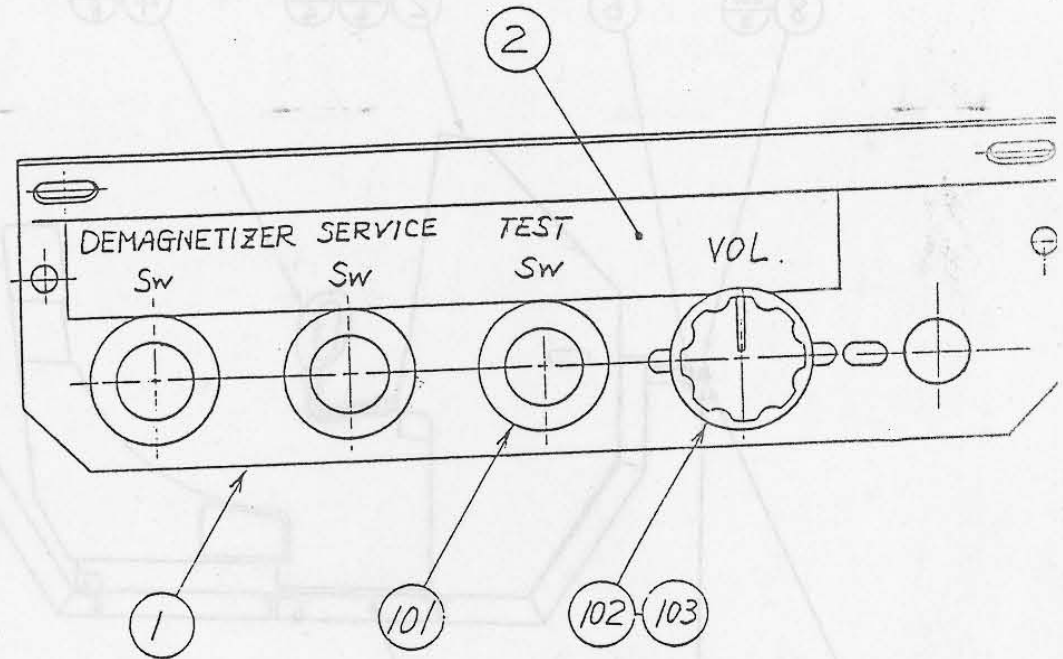

ITEM NO.	PART NO.	DESCRIPTION
1	KR-1405	SW. BRACKET
2	421-6511	STICKER SW.
101	509-5028	SW. PB 1M
102	601-0042	KNOB 22mm
103	220-5179	VOL. CONT B-5K OHM

⑦ ASSY GONDOLA TX-1000

4090-XT T100 W2

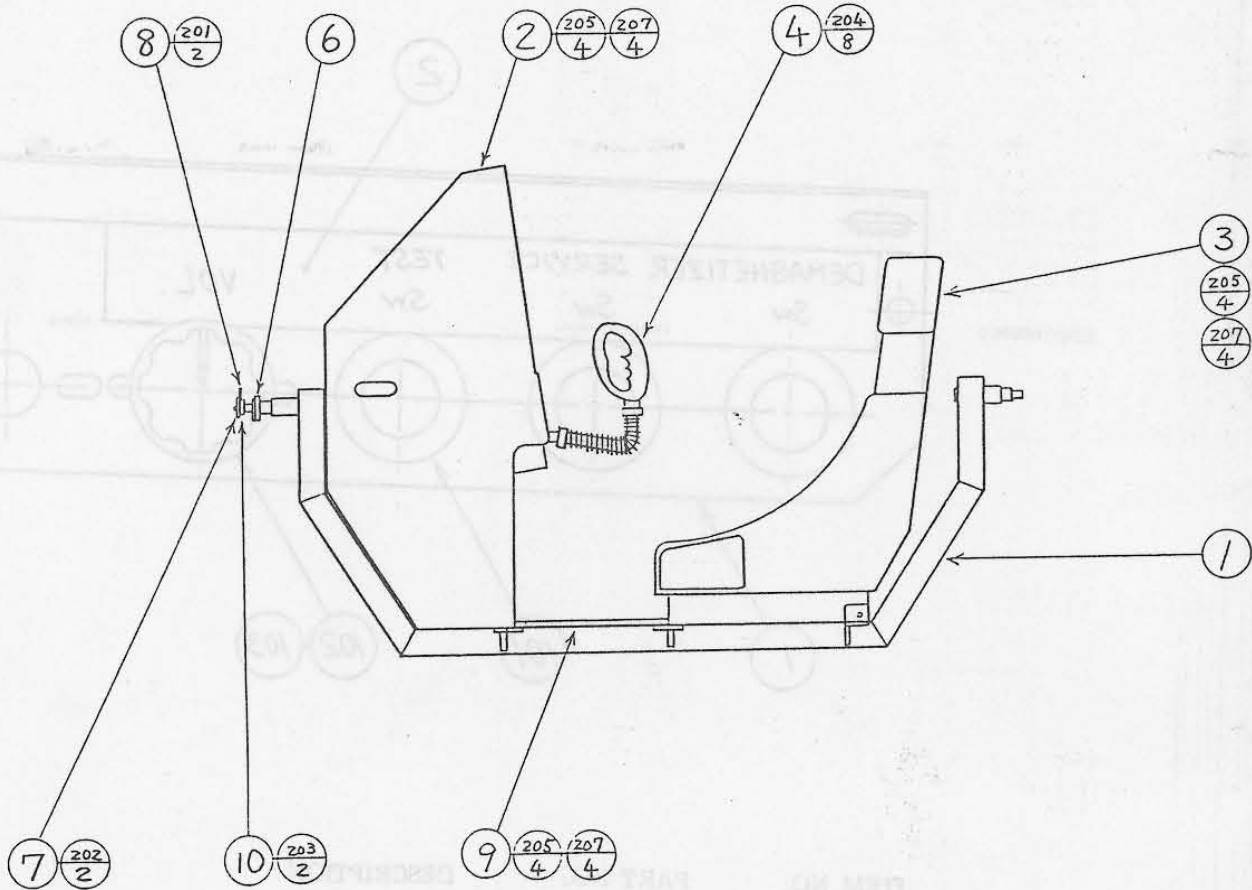

ITEM NO.	PART NO.	DESCRIPTION
1	TX-1001	GONDOLA
2	TX-1100	ASSY CABINET FRONT
3	TX-1200	ASSY CABINET REAR
4	TX-1300	ASSY CONTROL UNIT
6	TX-1002	CAM
7	TX-1003	ADJUST PLATE
8	601-5863	GEAR 1/4
9	TX-1004	ASSY FLOOR BD
10	MX-2017	ADJUSTER
201	000-0408-S	M SCR PH W/S M4×8
202	000-0408-FS	M SCR PH W/FS M4×8
203	028-0021	SET SCR PH SPCL M4×16
204	008-0525	TMP PRF SCR TH M5×25
205	039-0037	HEX BLT BLK M8×30
207	069-0035	FLT WSHR BLK M8

⑧ ASSY CABINET FRONT TX-1100 (D-1/2)

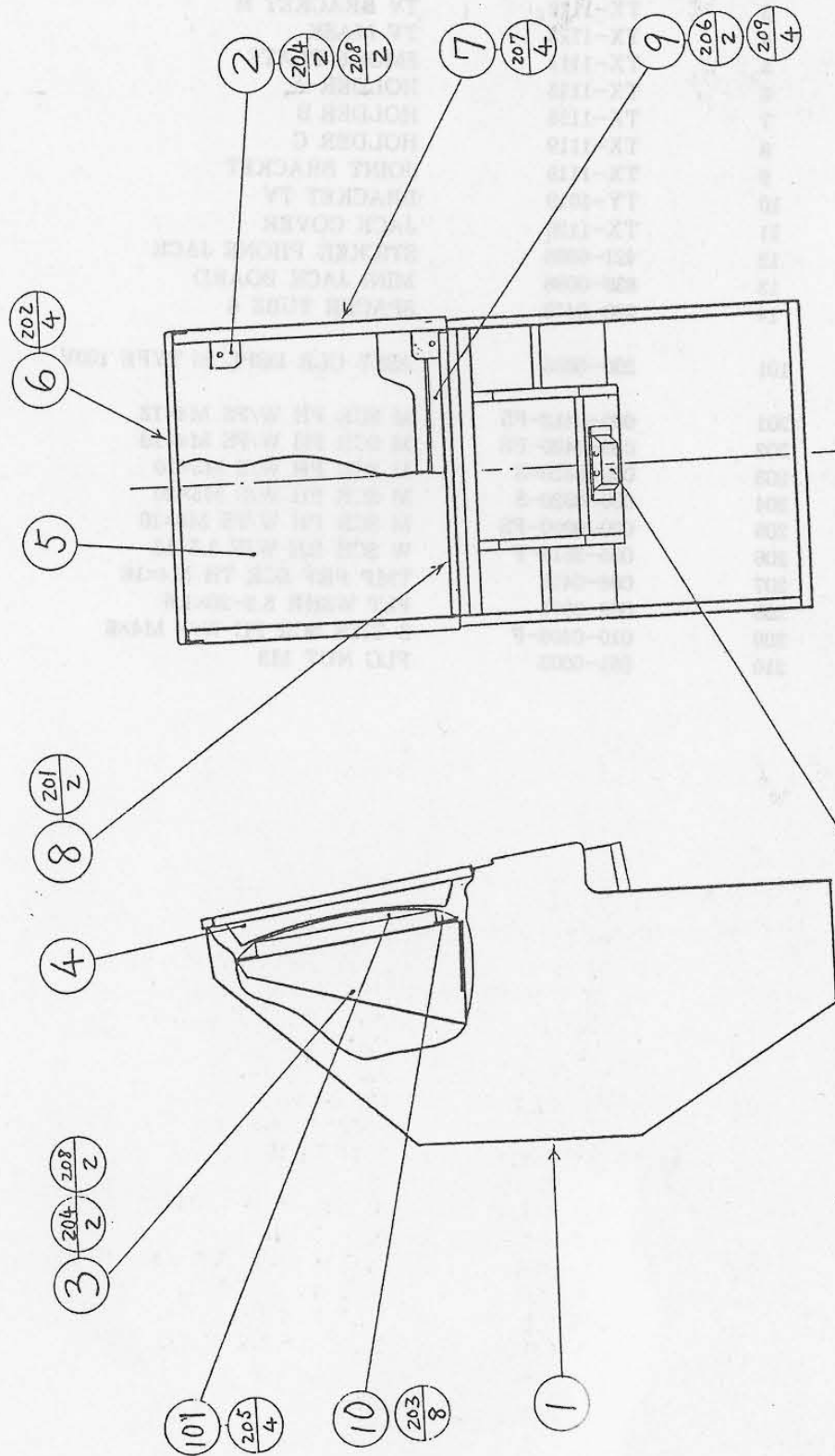

⑧ ASSY CABINET FRONT TX-1100 (D-2/2)

ITEM NO.	PART NO.	DESCRIPTION
1	TX-1101	ASSY SUBCABI FRONT
2	TX-1111	TV BRACKET L
3	TX-1112	TV BRACKET R
4	TX-1113	TV MASK
5	TX-1114	SMOKE PLATE
6	TX-1115	HOLDER A
7	TX-1116	HOLDER B
8	TX-1119	HOLDER C
9	TX-1119	JOINT BRACKET
10	TY-1019	BRACKET TV
11	TX-1120	JACK COVER
12	421-6986	STICKER PHONE JACK
13	839-0098	MINI JACK BOARD
14	280-0479	SPACER TUBE 6
101	200-5095	ASSY CLR DSPL 20 TYPE 100V
201	000-0412-FS	M SCR PH W/FS M4×12
202	000-0420-FS	M SCR PH W/FS M4×20
203	000-0510-S	M SCR PH W/S M5×10
204	000-0520-S	M SCR PH W/S M5×20
205	000-0510-FS	M SCR PH W/FS M5×10
206	005-3513-F	W SCR RH W/F 3.5×13
207	008-0416	TMP PRF SCR TH M4×16
208	069-0001	FLT WSHR 5.5-20×1.6
209	010-0406-F	S-TITE SCR PH W/F M4×6
210	051-0003	FLG NUT M3

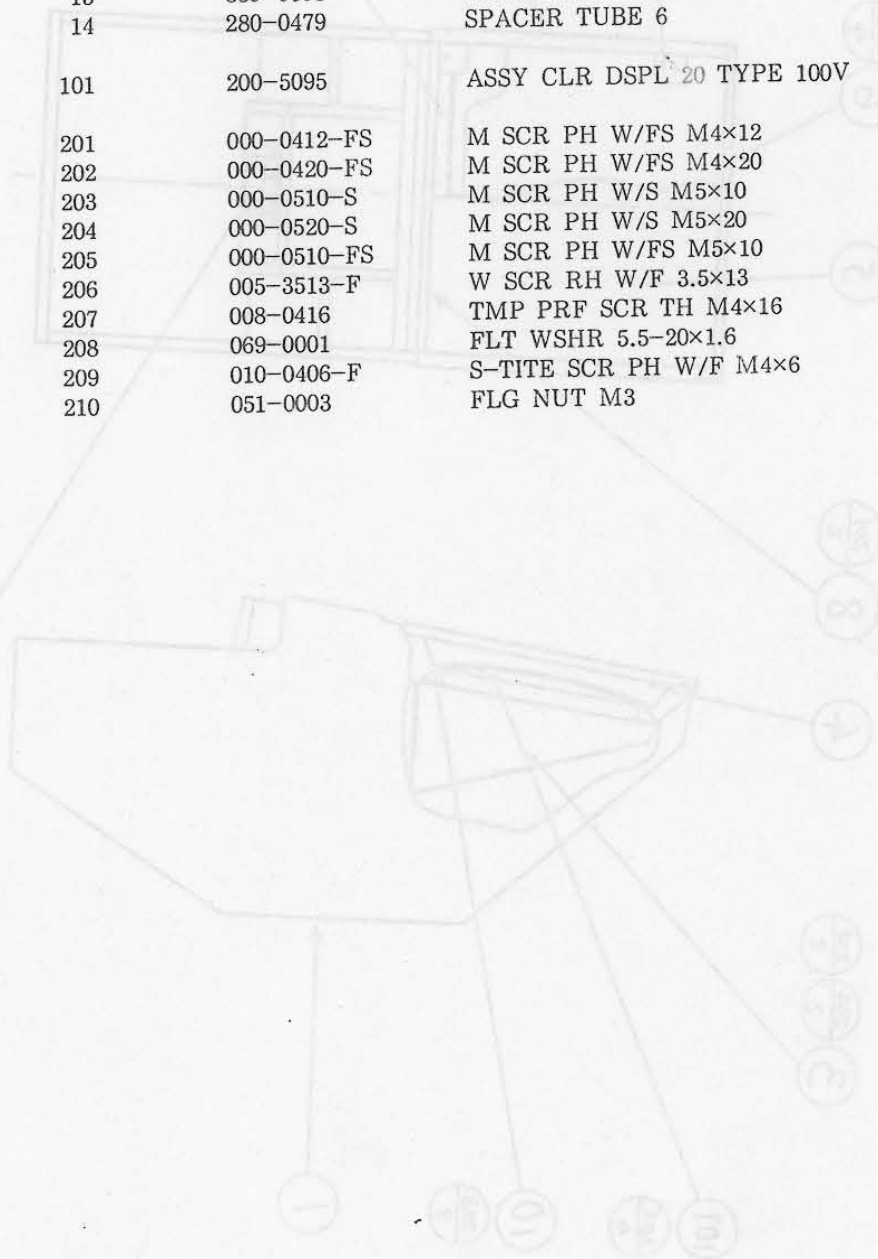

⑨ ASSY CABINET REAR TX-1200 (D-1/2)

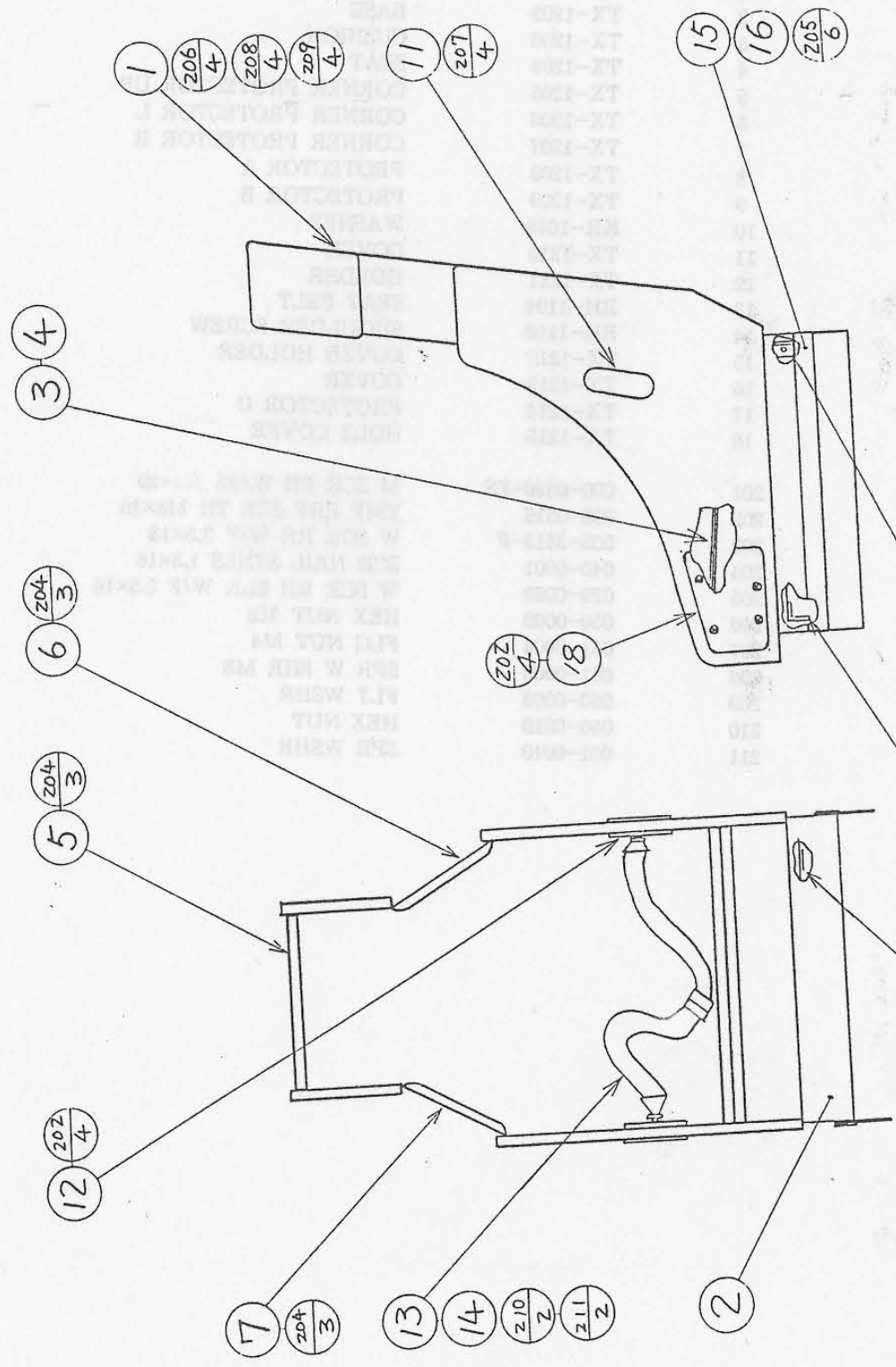

⑨ ASSY CABINET REAR TX-1200 (D-2/2)

ITEM NO.	PART NO.	DESCRIPTION
1	TX-1201	CABINET REAR
2	TX-1202	BASE
3	TX-1203	CUSHION
4	TX-1204	SEAT
5	TX-1205	CORNER PROTECTOR UP
6	TX-1206	CORNER PROTECTOR L
7	TX-1207	CORNER PROTECTOR R
8	TX-1208	PROTECTOR A
9	TX-1209	PROTECTOR B
10	KR-1045	WASHER
11	TX-1210	COVER
12	TX-1211	HOLDER
13	RH-1104	SEAT BELT
14	RH-1118	SHOULDER SCREW
15	TX-1212	COVER HOLDER
16	TX-1213	COVER
17	TX-1214	PROTECTOR C
18	TX-1215	HOLE COVER
201	000-0520-FS	M SCR PH W/FS M5×20
202	008-0516	TMP PRF SCR TH M5×16
203	005-3513-F	W SCR RH W/F 3.5×13
204	046-0001	SCR NAIL STNLS 1.5×16
205	029-0059	W SCR RH BLK W/F 3.5×16
206	050-0008	HEX NUT M8
207	051-0004	FLG NUT M4
208	061-0008	SPR W SHR M8
209	060-0008	FLT WSHR
210	050-0010	HEX NUT
211	061-0010	SPR WSHR

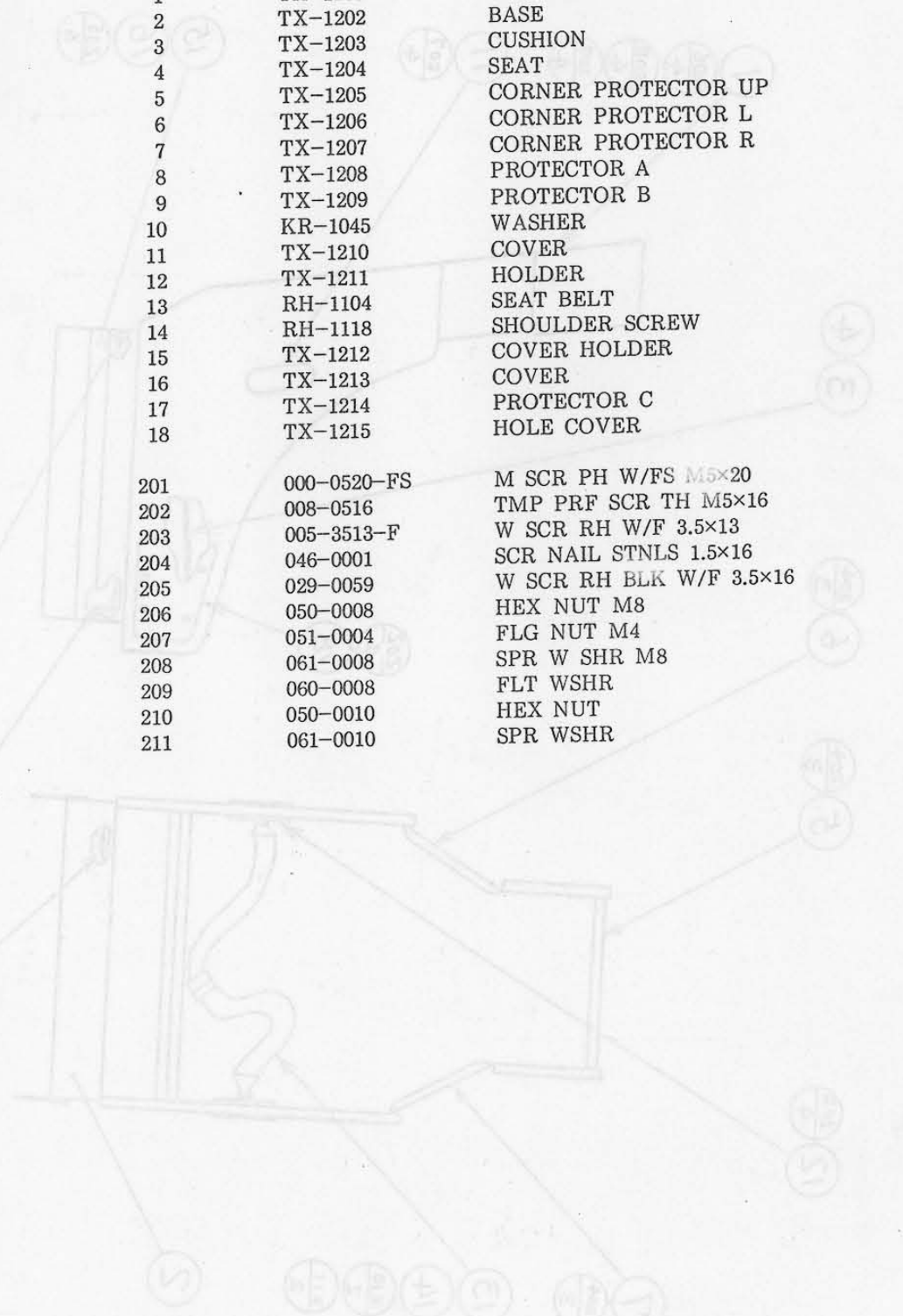

⑩ ASSY CONTROL UNIT TX-1300 (D-1/3)

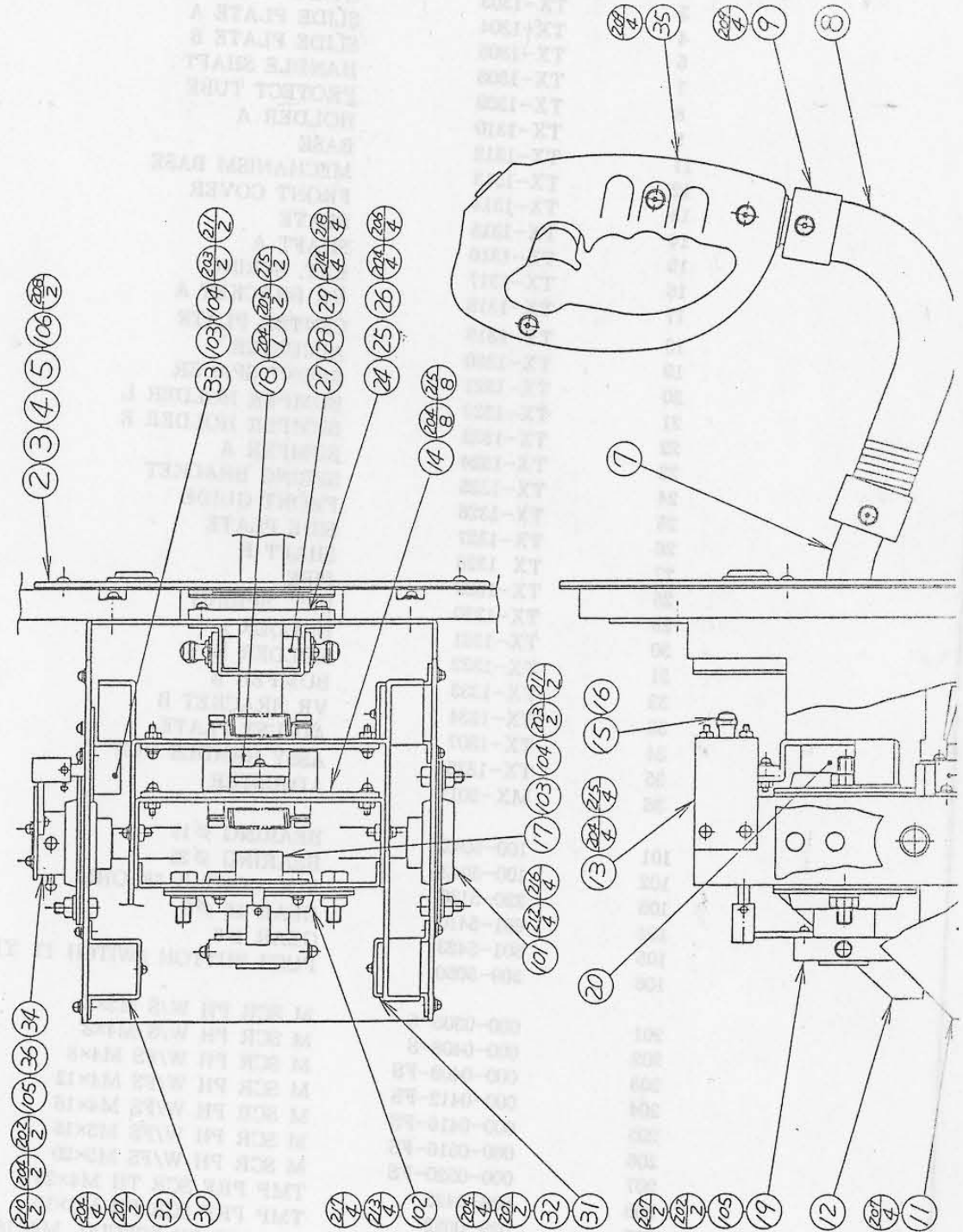

⑩ ASSY CONTROL UNIT TX-1300 (D-2/3) 03 Y23A ⑩

ITEM NO.	PART NO.	DESCRIPTION
1	TX-1301	CONT PNL BASE
2	TX-1302	DESIGN PANEL
3	TX-1303	GUIDE PLATE
4	TX-1304	SLIDE PLATE A
5	TX-1305	SLIDE PLATE B
7	TX-1308	HANDLE SHAFT
8	TX-1309	PROTECT TUBE
9	TX-1310	HOLDER A
	TX-1310	BASE
11	TX-1312	MECHANISM BASE
12	TX-1313	FRONT COVER
13	TX-1314	PLATE
14	TX-1315	SHAFT A
15	TX-1316	EXT. SPRING
16	TX-1317	VR BRACKET A
17	TX-1318	CENTER PLATE
18	TX-1319	ADJUSTER
19	TX-1320	FRONT SPACER
20	TX-1321	BUMPER HOLDER L
21	TX-1322	BUMPER HOLDER R
22	TX-1323	BUMPER A
23	TX-1324	SPRING BRACKET
24	TX-1325	FRONT GUIDE
25	TX-1326	SIDE PLATE
26	TX-1327	SHAFT B
27	TX 1328	PIPE
28	TX-1329	EXT. SPRING
29	TX-1330	HOLDER L
30	TX-1331	HOLDER R
31	TX-1332	BUMPER B
32	TX-1333	VR BRACKET B
33	TX-1334	ADJUST PLATE
34	TX-1307	ASSY HANDLE GLIP
35	TX-1335	ADJUSTER
36	MX-2017	
101	100-5042	BEARING ϕ 12
102	100-5043	BEARING ϕ 25
103	220-5130	VOL CONT B-5K OHM
104	601-5410	GEAR 15 ϕ 6
105	601-5423	GEAR 1/6
106	509-5050	PUSH BUTTON SWITCH 1T YELLOW W/LAMP
201	000-0305-5	M SCR PH W/S M3x5
202	000-0408-S	M SCR PH W/S M4x8
203	000-0408-FS	M SCR PH W/FS M4x8
204	000-0412-FS	M SCR PH W/FS M4x12
205	000-0416-FS	M SCR PH W/FS M4x16
206	000-0516-FS	M SCR PH W/FS M5x16
207	000-0520-FS	M SCR PH W/FS M5x20
208	008-0425	TMP PRF SCR TH M4x25
209	029-0052	TMP PRF SCR PH M5x10
210	028-0021	SET SCR PH SPECIAL M4x16
211	028-0003	SET SCR PH SPECIAL M3x8
212	061-0006	SPR WSHR M6
213	061-0008	SPR WSHR M8
214	060-0008	FLT WSHR M8
215	054-0004	U-NUT M4

⑩ ASSY CONTROL UNIT TX-1300 (D-3/3)

ITEM NO.	PART NO.	DESCRIPTION
216	054-0006	U-NUT M6
217	050-0008	HEX NUT M8
218	065-0006	E RING 6mm

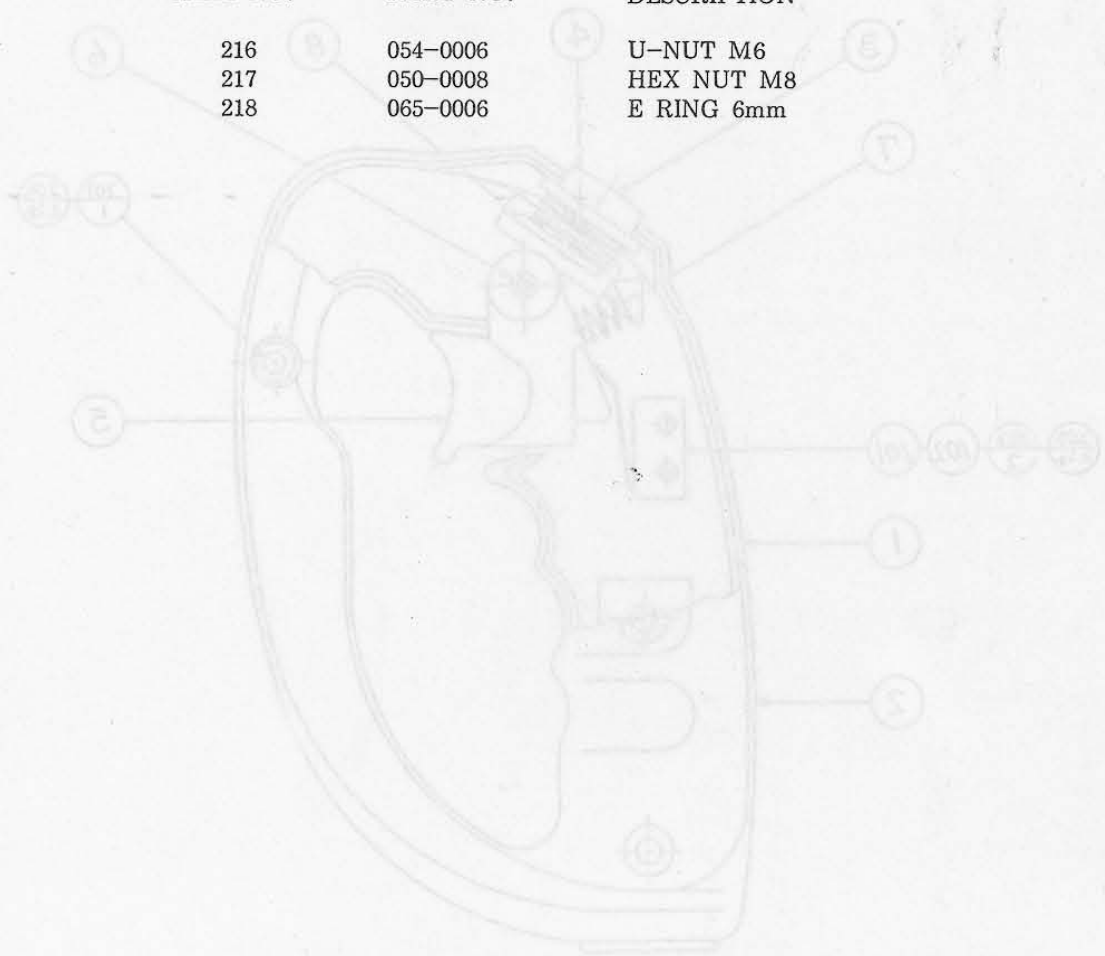

ITEM NO.	PART NO.	DESCRIPTION
101	300-0028	SWITCH KNOB TYPE (MOLON EL-200)
102	200-0029	THERMO-SPRINK TUBE ILLUMINATE TRANSPARENT
201	000-0022	TAP PIP FOR M6-M8
202	000-0124	M SCR FOR M6-M8
203	044-044	GLASS SCR LOCK
204	044-100	LOCKWASHER SPR
10	211-0041	DOWN PIN AMP
2	000-0021	WIRE HARN HANDLE GRIP
3	000-0027	SW BOARD
7	122-0011	COMPRESSION SPRING
4	01-2042	SLAFT TRIGGER
5	01-2041	TRIGGER
4	01-1208	COMPRESSION SPRING
2	01-1207	HANDLE GRIP RIGHT
1	01-1206	HANDLE GRIP LEFT

⑪ ASSY HANDLE GRIP TX-1335

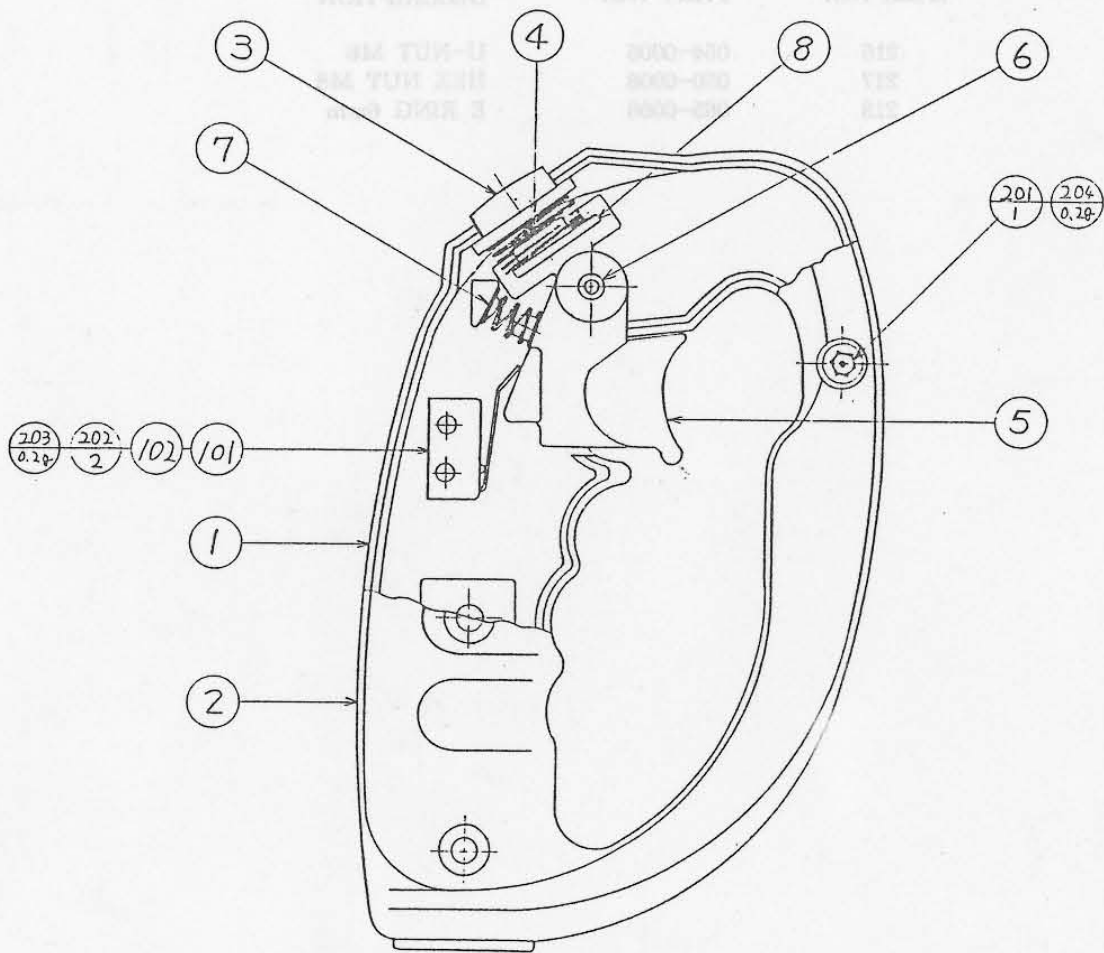

ITEM NO.	PART NO.	DESCRIPTION
1	TX-1336	HANDLE GRIP LEFT
2	TX-1337	HANDLE GRIP RIGHT
3	TX-1338	BUTTON
4	TX-1339	COMPRESSION SPRING
5	CD-2041	TRIGGER
6	CD-2042	SHAFT TRIGGER
7	125-0011	COMPRESSION SPRING
8	839-0087	SW BOARD
9	600-5521	WIRE HARN HANDLE GRIP
10	211-0041	CONN PIN AMP
101	509-0058	SWITCH MICRO TYPE (MULON SL-220)
102	530-0028	THERMO-SHRINK TUBE HISHILITE TRANSPARENT 4mm
201	029-0052	TMP PRF SCR PH M5×10
202	029-0134	M SCR PH M2×10
203	244-044	GLUE SCR LOOK
204	244-106	LOCTITE #271

⑫ ASSY CRADLE TX-2000 (D-1/3)

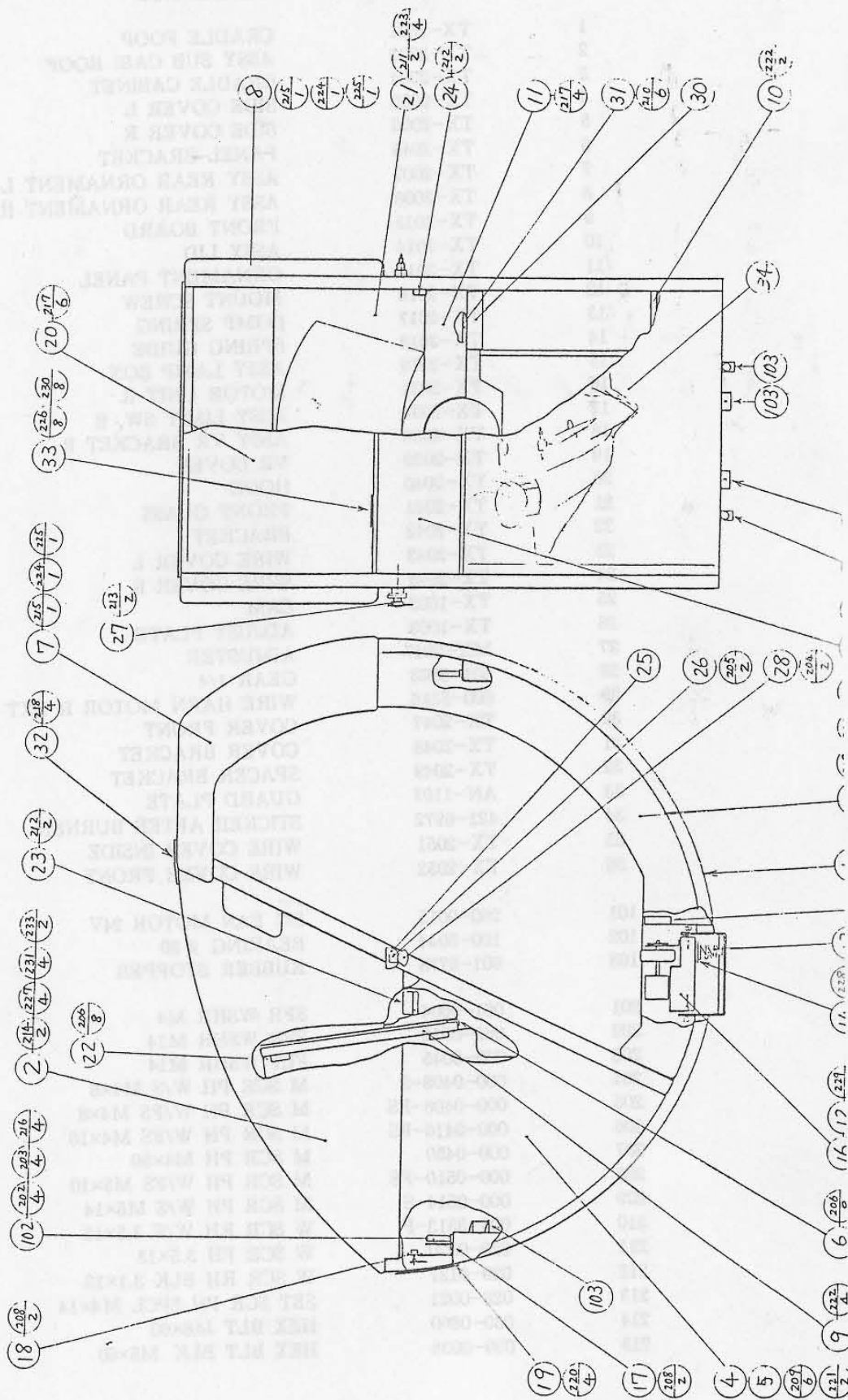

⑫ ASSY CRADLE TX-2000 (D-2/3)

ITEM NO.	PART NO.	DESCRIPTION
1	TX-2001	CRADLE FOOP
2	TX-2002	ASSY SUB CABI ROOF
3	TX-2004	CRADLE CABINET
4	TX-2005	SIDE COVER L
5	TX-2006	SIDE COVER R
6	TX-2045	PANEL BRACKET
7	TX-2007	ASSY REAR ORNAMENT L
8	TX-2008	ASSY REAR ORNAMENT R
9	TX-2013	FRONT BOARD
10	TX-2014	ASSY LID
11	TX-2015	ORNAMENT PANEL
12	TX-2016	MOUNT SCREW
13	TX-2017	COMP SPRING
14	TX-2018	SPRING GUIDE
15	TX-2019	ASSY LAMP BOX
16	TX-2031	MOTOR UNIT R
17	TX-2034	ASSY LIMIT SW. R
18	TX-2036	ASSY VR BRACKET R
19	TX-2039	VR COVER
20	TX-2040	HOOD
21	TX-2041	FRONT GLASS
22	TX-2042	BRACKET
23	TX-2043	WIRE COVER L
24	TX-2044	WIRE COVER R
25	TX-1002	CAM
26	TX-1003	ADJUST PLATE
27	MX-2017	ADJUSTER
28	601-5863	GEAR 1/4
29	600-5516	WIRE HARN MOTOR R EXT B
30	TX-2047	COVER FRONT
31	TX-2048	COVER BRACKET
32	TX-2049	SPACER BRACKET
33	AN-1107	GUARD PLATE
34	421-6972	STICKER AFTER BURNER
35	TX-2051	WIRE COVER INSIDE
36	TX-2052	WIRE COVER FRONT
101	260-0015	DC FAN MOTOR 24V
102	100-5044	BEARING \varnothing 30
103	601-5778	RUBBER STOPPER
201	061-0004	SPR WSHR M4
202	069-0019	SPR WSHR M14
203	069-0045	FLT WSHR M14
204	000-0408-S	M SCR PH W/S M4x8
205	000-0408-FS	M SCR PH W/FS M4x8
206	000-0416-FS	M SCR PH W/FS M4x16
207	000-0450	M SCR PH M4x50
208	000-0510-FS	M SCR PH W/FS M5x10
209	000-0514-S	M SCR PH W/S M5x14
210	005-3513-F	W SCR RH W/F 3.5x13
211	029-0020	W SCR FH 3.5x13
212	029-0127	W SCR RH BLK 3.1x13
213	028-0021	SET SCR PH SPCL M4x14
214	030-0860	HEX BLT M8x60
215	039-0038	HEX BLT BLK M5x60

⑫ ASSY CRADLE TX-2000 (D-3/3)

ITEM NO.	PART NO.	DESCRIPTION
216	039-0035	HEX BLT M14×35
217	008-0410	TMP PRF SCR TH M4×10
218	008-0416	TMP PRF SCR TH M4×16
219	008-0430	TMP PRF SCR TH M4×30
220	008-0510	TMP PRF SCR TH M5×10
221	008-0512	TMP PRF SCR TH M5×12
222	008-0525	TMP PRF SCR TH M5×25
223	008-0420	TMP PRF SCR TH M4×20
224	008-0535	TMP PRF SCR TH M5×35
225	008-0545	TMP PRF SCR TH M5×45
226	031-0410-B	CRG BLT BLK M4×10
227	031-0540	CRG BLT M5×40
228	039-0033	HEX BLT S=30 BLK M10×90
229	050-0010	HEX NUT M10
230	051-0004	FLG NUT M4
231	051-0005	FLG NUT M5
232	069-0028	FLT WSHR BLK 6.6-15×1.2
233	069-0035	FLT WSHR BLK M8

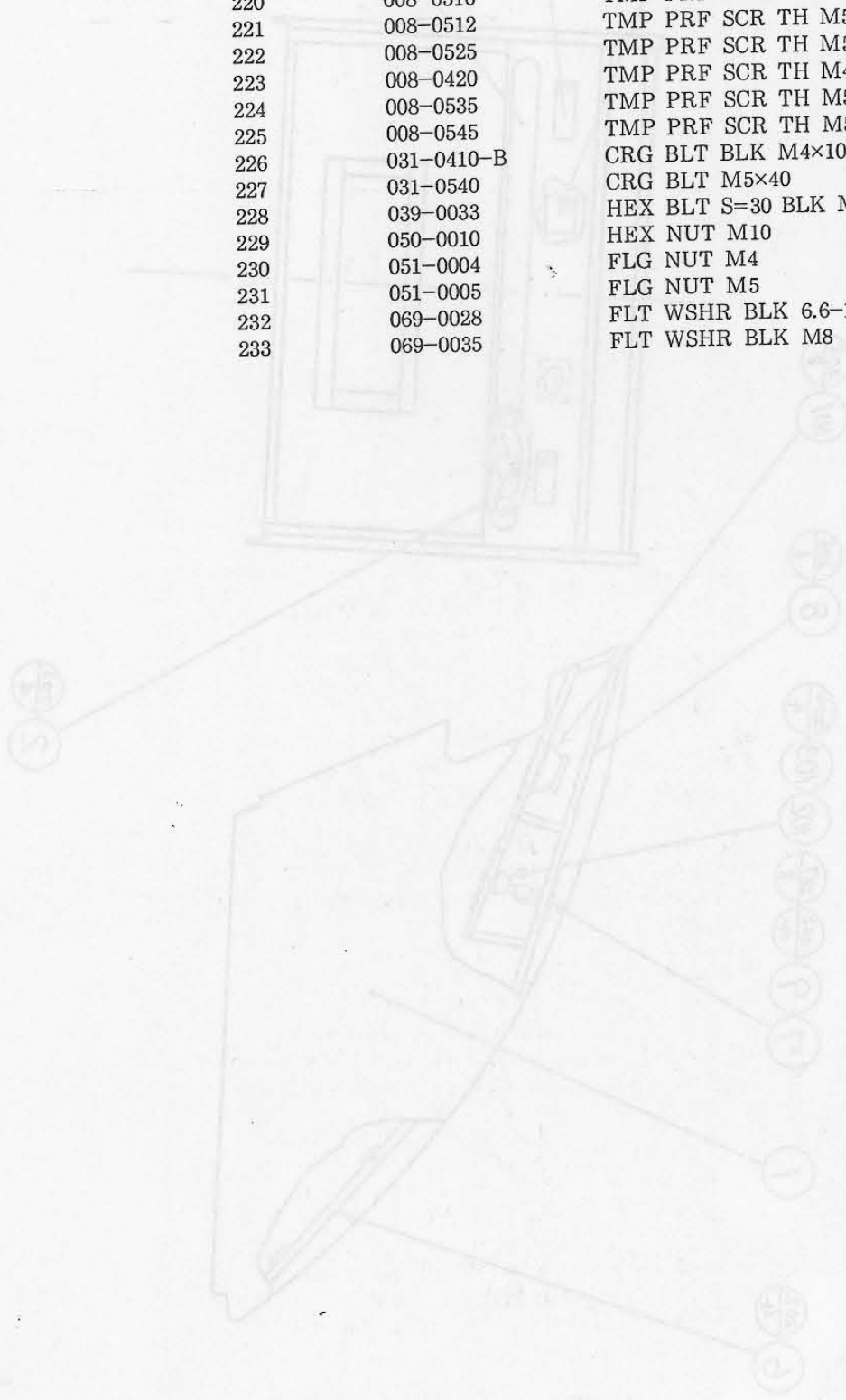

⑬ ASSY SUBCABI ROOF TX-2002 (D-1/2)

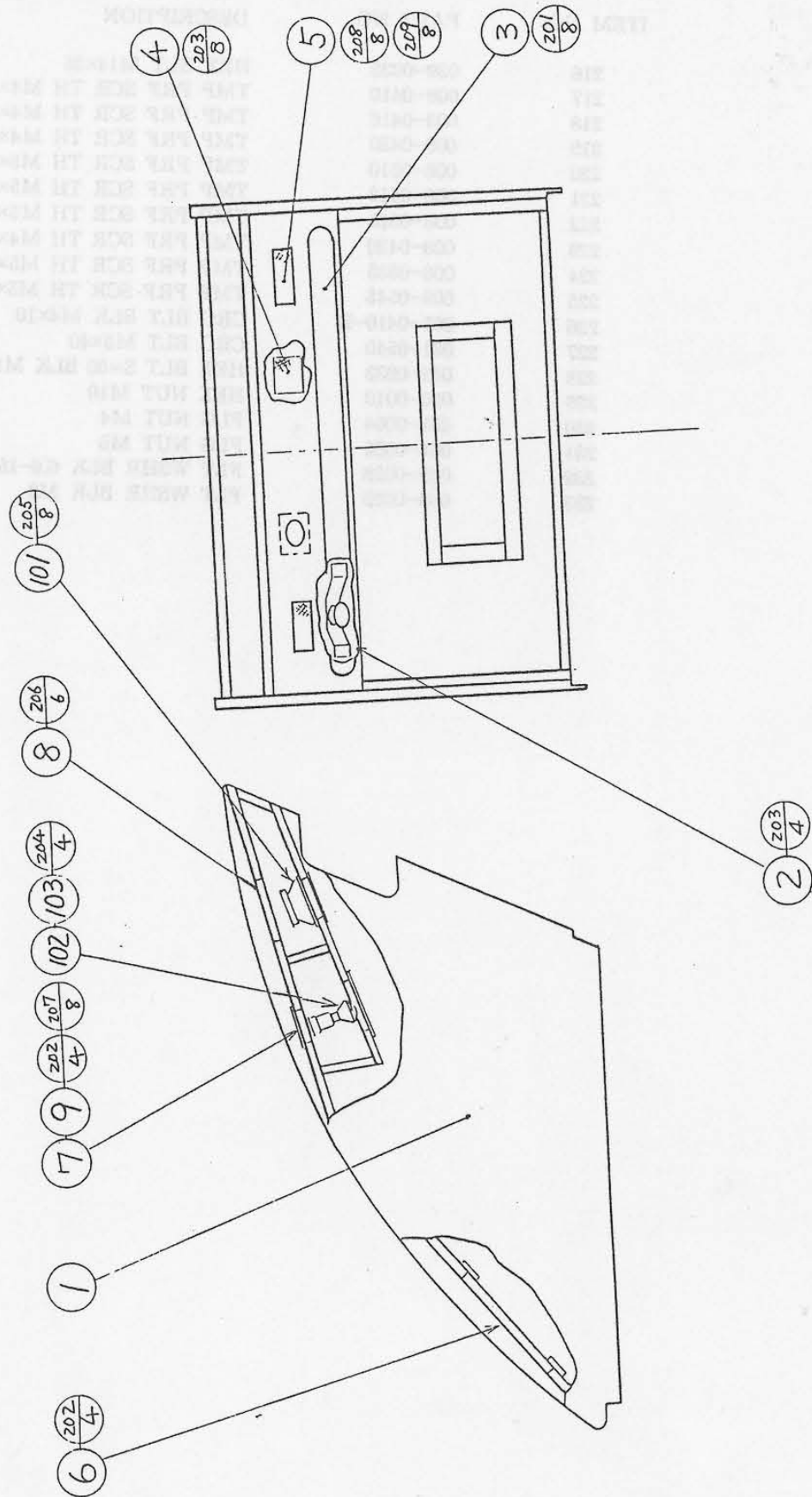

⑬ ASSY SUBCABI ROOF TX-2002 (D-2/2)

ITEM NO.	PART NO.	DESCRIPTION
1	TX-2003	CABINET ROOF
2	TX-2025	LAMP BRACKET
3	TX-2026	DESIGN PLATE
4	TX-2027	HOLE COVER
5	AN-1107	GUARD PLATE
6	TX-2028	SERVICE DOOR A
7	TX-2029	SERVICE DOOR B
8	TX-2030	SERVICE DOOR C
9	TX-2046	COVER
101	130-5019	SPEAKER 10cm 8Ω 15W
102	214-0110	BULB SOCKET
103	390-5167	LAMP 110V 30W
201	008-0420	TMP PRF SCR TH M4×20
202	008-0430	TMP PRF SCR TH M4×30
203	005-3513-F	W SCR RH W/F 3.5×13
204	000-0310	M SCR PH M3×10
205	005-3516-F	W SCR RH W/F 3.5×16
206	005-3525	W SCR RH 3.5×25
207	029-0127	W SCR RH BLK 3.1×13
208	031-0425-B	CRG BLT-BLK M4×25
209	051-0004	FLG NUT M4

LAMP BOX
 DESIGN PLATE WITH NUMBER
 CORNER PLATE
 CORNER PLATE
 LAMP BRACKET
 DESIGN PLATE
 ASSY FL LIGHT RW MELLOW LOCK
 SPEAKER 10cm 8Ω 15W
 M SCR PH M4×20
 W SCR RH W/F 3.5×13
 M SCR PH M3×10
 W SCR RH W/F 3.5×16
 W SCR RH 3.5×25
 W SCR RH BLK 3.1×13
 CRG BLT-BLK M4×25
 FLG NUT M4

⑭ ASSY LAMP BOX TX-2019 (D-1/2)

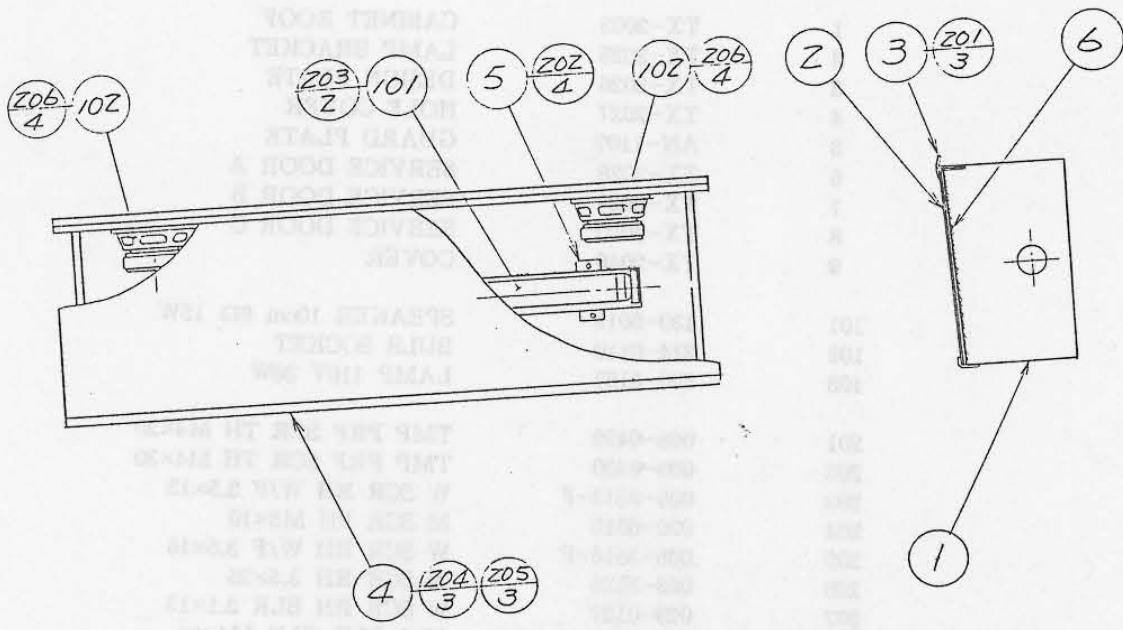

ITEM NO.	PART NO.	DESCRIPTION
1	TX-2020	LAMP BOX
2	423-0066	DESIGN PLATE AFTER BURNER
3	TX-2022	CORNER UPPER
4	TX-2023	CORNER LOWER
5	TX-2024	FL BRACKET
6	TX-2050	PLASTIC PLATE
101	390-5149	ASSY FL LIGHT 30W MELLOW LOOK
102	130-5020	SPEAKER 10cm 80HM 15W
201	001-0414	M SCR FH M4×14
202	005-3513-F	W SCR RH W/F 3.5×13
203	010-0406-F	S TITE SCR PH W/F M4×6
204	000-0414	M SCR PH M4×14
205	060-0004	FLT WSHR M4
206	000-0416	M SCR PH W/SF M4×16

⑮ MOTOR UNIT R TX-2031

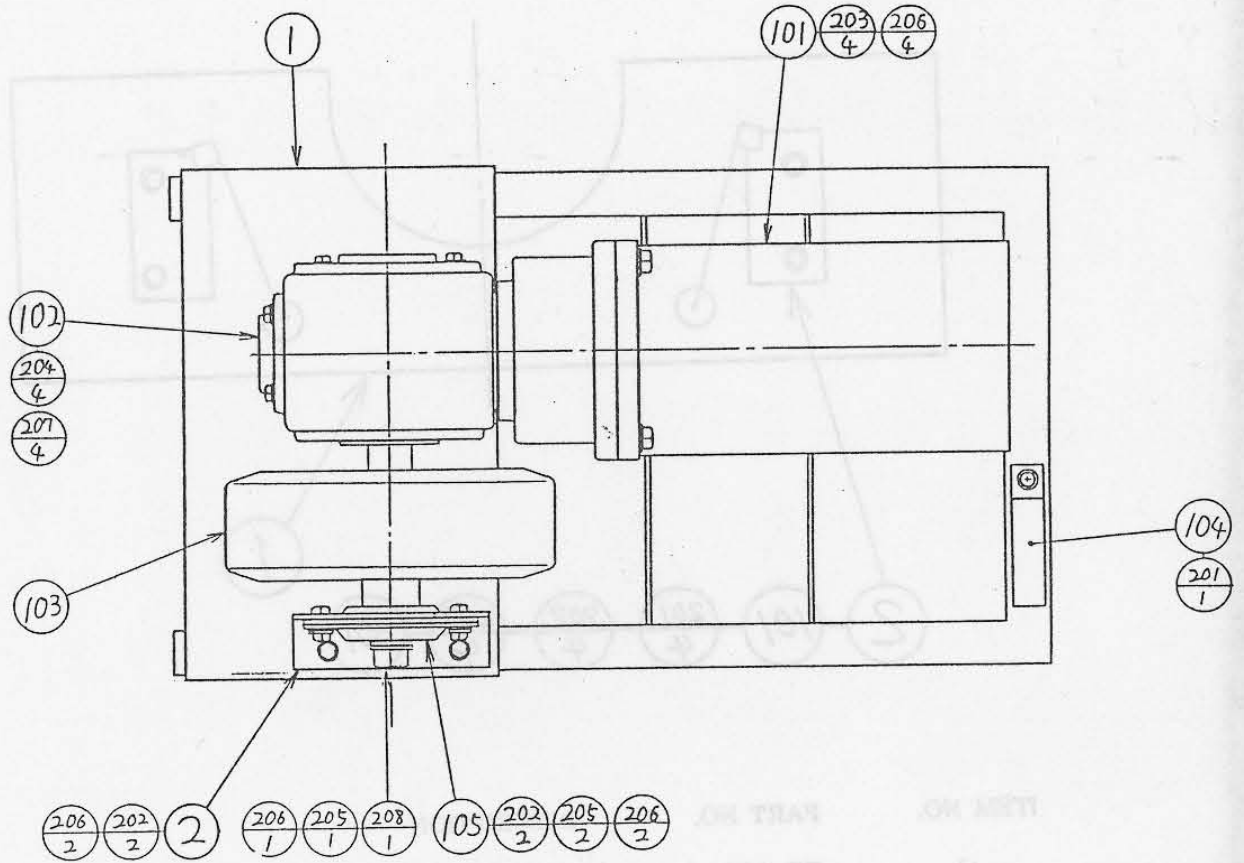

ITEM NO.	PART NO.	DESCRIPTION
1	TX-2032	MOTOR BASE
2	TX-2033	PILLOW BRACKET
101	350-5107	MOTOR DC 80V
102	350-5111	WORM SPEED REDUCER 1/50
103	601-5849	RUBBER WHEEL
104	270-5009	LINE FILTER
105	100-5045	BEARING $\varnothing 15$
201	010-0410-F	S TITE SCR PH W/F M4x10
202	030-0620	HEX BLT M6x20
203	030-0625	HEX BLT M6x25
204	030-0820	HEX BLT M8x20
205	060-0006	FLT WSHR M6
206	061-0006	SPR WSHR M6
207	061-0008	SPR WSHR M8
208	030-0610	HEX BLT M6x10

⑩ ASSY LIMIT SW. R TX-2034

MOTOR UNIT R TX-2031

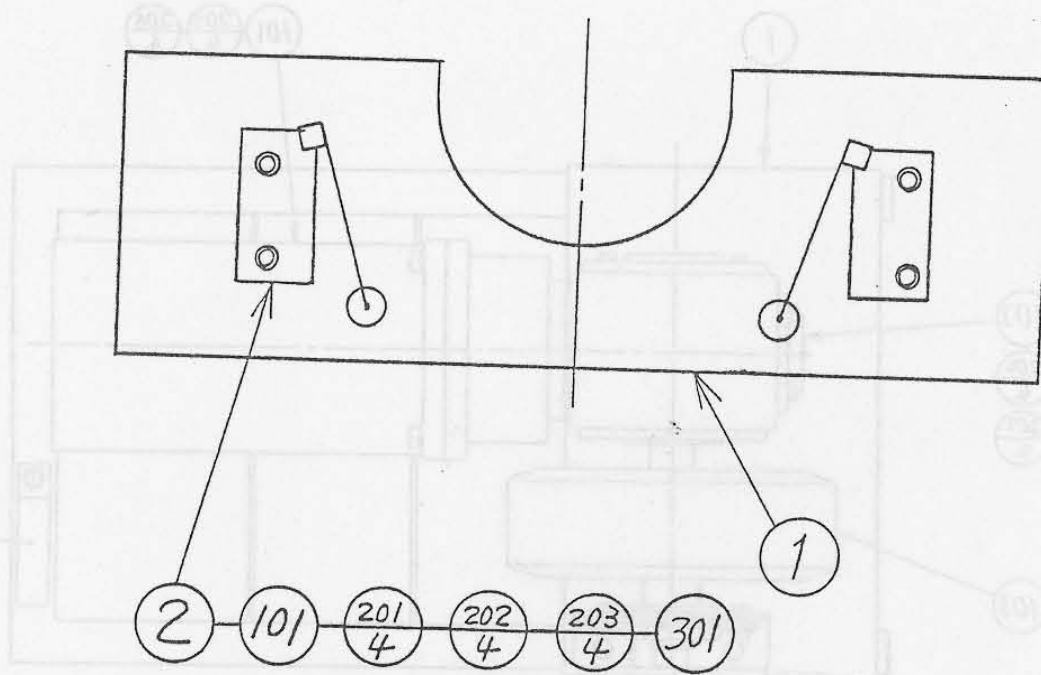

ITEM NO.	PART NO.	DESCRIPTION
1	TX-2035	LIMIT SW. BRACKET R
2	KR-3023	LIMIT SW. NUT PLATE
101	509-5199	SW. MICRO TYPE
201	000-0430	M. SCR P.HM4x30
202	060-0004	FLT WSHR M4
203	061-0004	SPR WSHR M4

⑰ ASSY VR BRACKET R TX-2036

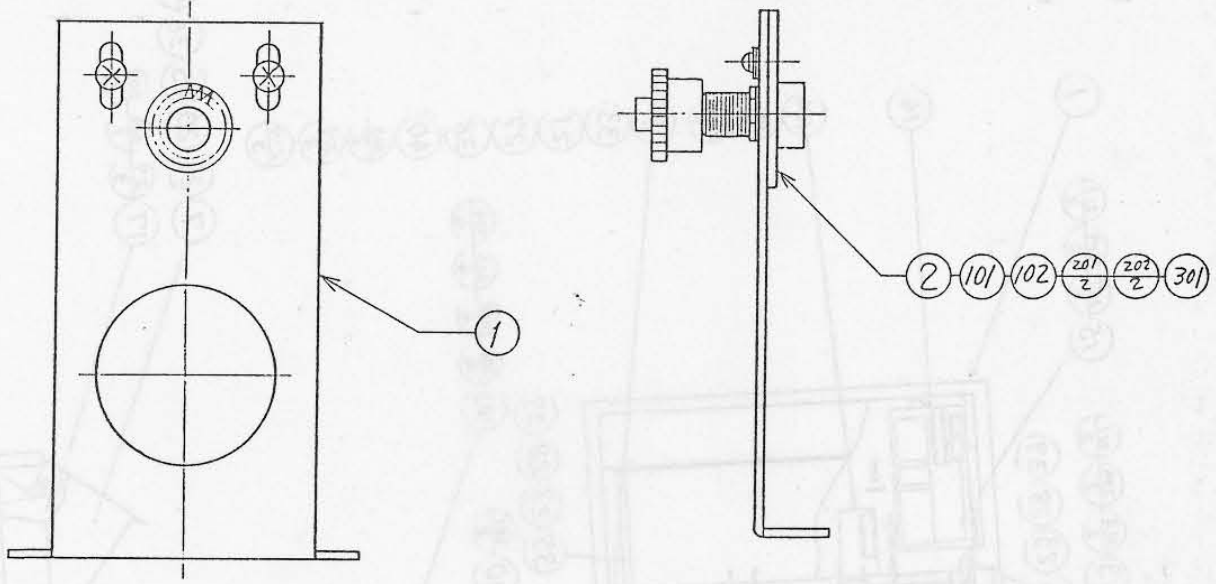

ITEM NO.	PART NO.	DESCRIPTION
1	TX-2037	VR BRKT R
2	TX-2038	VR ADJUST PLATE
101	601-5424	GEAR 30
102	220-5130	VOL CONT B-5KOHM
201	000-0408-FS	M SCR P.H W/FS M4x8
202	028-0014	SET HEX SKT CP UNBR M4x4

⑧ ASSY BASE TX-3000 (D-1/3)

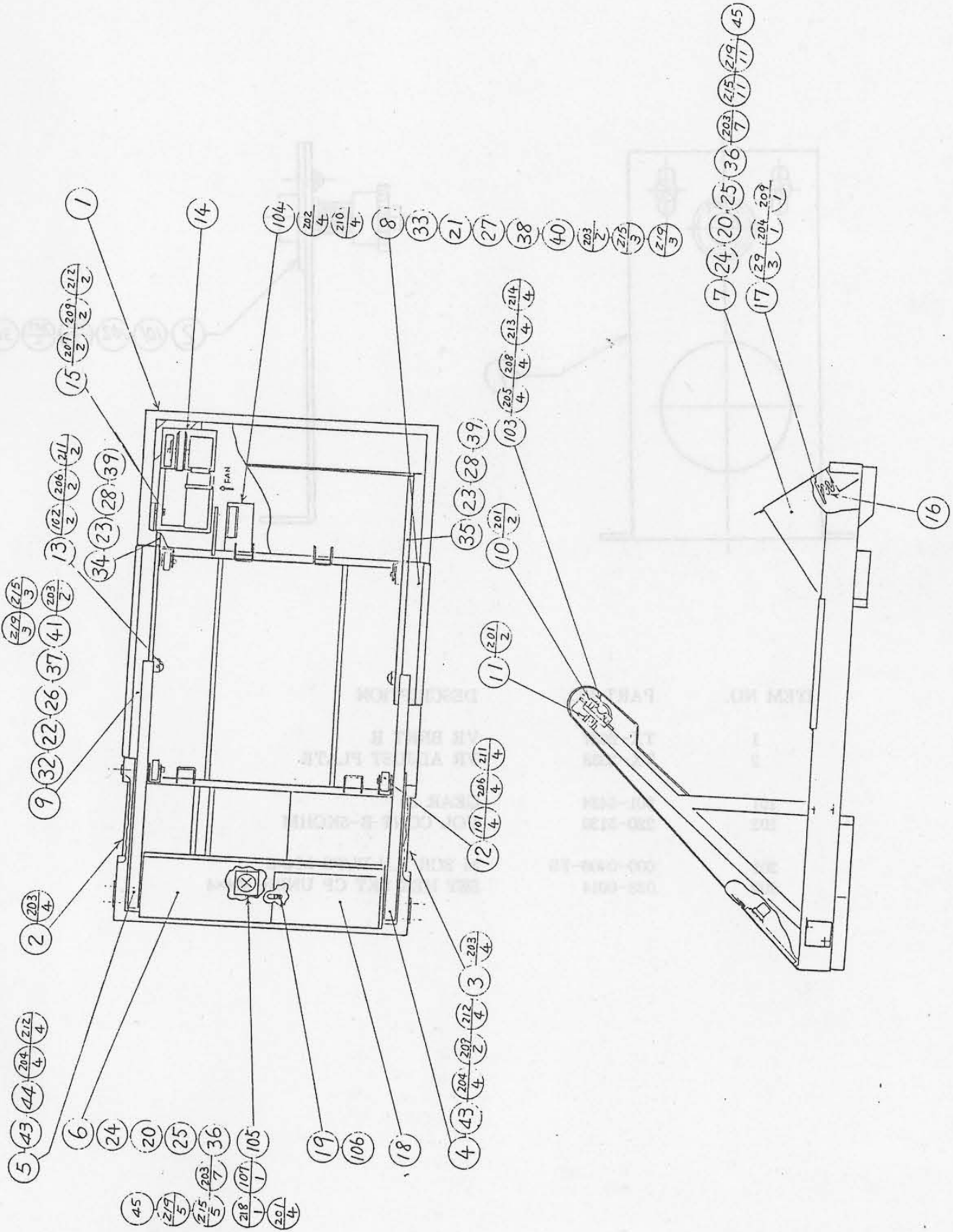

ⓑ ASSY BASE TX-3000 (D-2/3)

ITEM NO.	PART NO.	DESCRIPTION
1	TX-3001	BASE
2	TX-3002	AC UNIT
3	TX-3004	OUTPUT UNIT
4	TX-3006	PILLAR L
5	TX-3007	PILLAR R
6	TX-3008	COVER F
7	TX-3009	COVER R
8	TX-3010	STEP L
9	TX-3011	STEP R
10	TX-3012	ASSY LIMIT SW P
11	TX-3014	ASSY VR P
12	TX-3016	SHOULDER SCREW L
13	TX-3017	SHOULDER SCREW S
14	TX-3018	MOTOR UNIT P
15	TX-2016	MOUNT SCREW
16	TX-2017	COMP SPRING
17	TX-2018	SPRING GUIDE
18	TX-3019	SERVICE DOOR
19	DP-1167	LKG TNG
20	TX-3020	RUBBER BRKT A
21	TX-3021	RUBBER BRKT B
22	TX-3022	RUBBER BRKT C
23	TX-3023	RUBBER BRKT D
24	TX-3024	RUBBER A
25	TX-3025	RUBBER B
26	TX-3026	RUBBER C
27	TX-3027	RUBBER D
28	TX-3028	RUBBER E
29	TX-3029	SPACER RING
30	600-5515	WIRE HARN MOTOR R EXT A
31	600-5517	WIRE HARN MOTOR P EXT
32	TX-3030	SHEET A
33	TX-3031	SHEET B
34	TX-3032	SHEET C
35	TX-3033	SHEET D
36	TX-3034	SUPPORT BRACKET A
37	TX-3035	SUPPORT BRACKET B
38	TX-3036	SUPPORT BRACKET C
39	TX-3037	SUPPORT BRACKET D
40	TX-3038	CORNER PROTECTOR L
41	TX-3039	CORNER PROTECTOR R
42	421-6971	STICKER SEGA
43	TX-3063	PLATE A
44	TX-3064	PLATE B
45	TX-3076	EDGE
101	601-5861	RUBBER WHEEL ϕ 75
102	601-5862	RUBBER WHEEL ϕ 50
103	100-5044	BEARING ϕ 30
104	260-0015	DC FAN MOTOR
105	260-0023	FAN MOTOR AC 100 V
106	220-5044-01	MAGNETIC LOCK MASTER W/O KEY
107	117-0184	TERMINAL PLATE IL 4P
108	601-5526-180	BUSH 1.6t

18 ASSY BASE TX-3000 (D-3/3)

ASSY BASE TX-3000 (D-3/3)

ITEM NO.	PART NO.	DESCRIPTION	ITEM NO.
201	000-0408-FS	M SCR PH W/FS M4x8	1
202	000-0450	M SCR PH	2
203	008-0510	TMP PRF SCR TH M5x10	3
204	039-0033	HEX BLT BLK M10x90 S=30	4
205	039-0036	HEX BLT S=30 M14x90	5
206	050-0008	HEX NUT M8	6
207	050-0010	HEX NUT M10	7
208	059-0016	HEX NUT M14	8
209	069-0061	FLT WSHR BLK M10	9
210	061-0004	SPR WSHR M4	10
211	061-0008	SPR WSHR M8	11
212	069-0063	SPR WSHR BLK M10	12
213	069-0019	SPR WSHR M14	13
214	069-0045	FLT WSHR M14	14
215	008-0516	TMP PRFSCR TH M5x16	15
218	010-0306-F	S TITE SCR PH W/F M3x6	16
219	051-0005	FLG NUT	17
			18
			19
			20
			21
			22
			23
			24
			25
			26
			27
			28
			29
			30
			31
			32
			33
			34
			35
			36
			37
			38
			39
			40
			41
			42
			43
			44
			45
			46
			47
			48
			49
			50
			51
			52
			53
			54
			55
			56
			57
			58
			59
			60
			61
			62
			63
			64
			65
			66
			67
			68
			69
			70
			71
			72
			73
			74
			75
			76
			77
			78
			79
			80
			81
			82
			83
			84
			85
			86
			87
			88
			89
			90
			91
			92
			93
			94
			95
			96
			97
			98
			99
			100

① AC UNIT TX-3002 (D-1/2)

① AC UNIT TX-3002 (D-1/2)

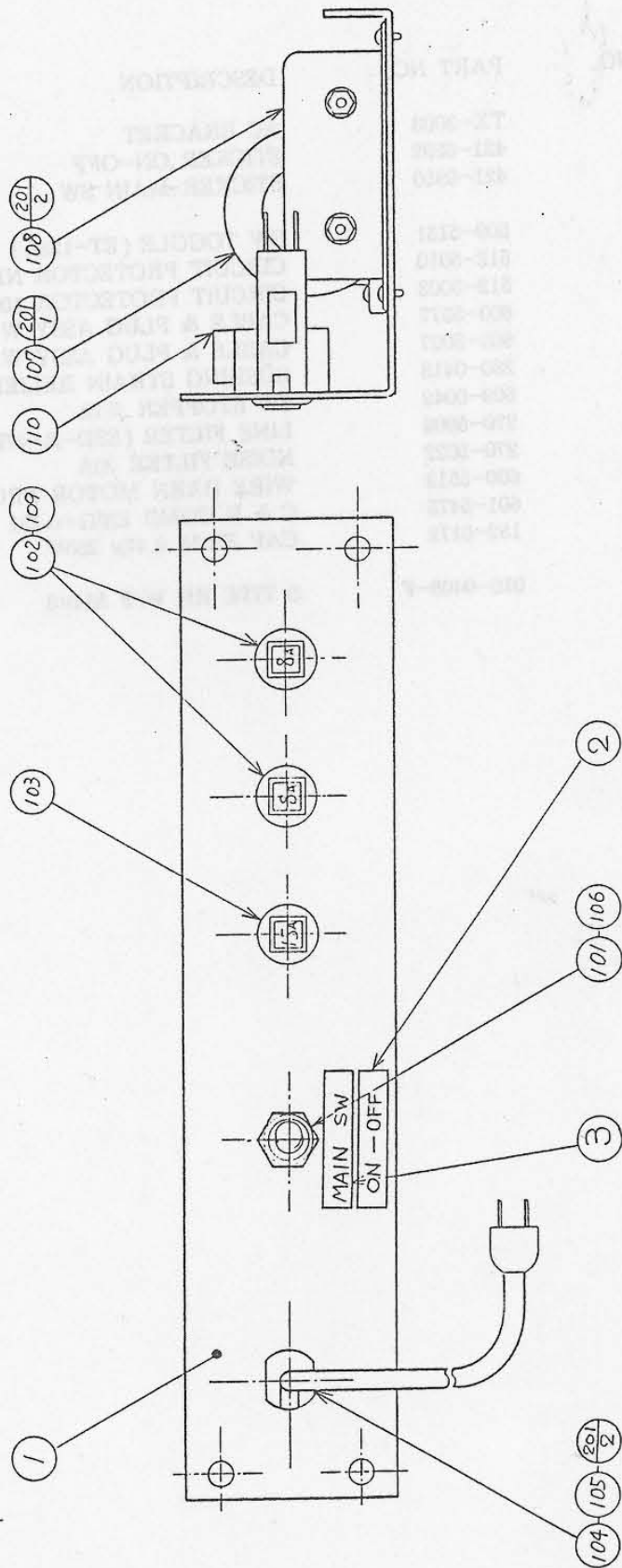

① AC UNIT TX-3002 (D-2/2)

(S1-1) 500E-XT TIMU JA ②

ITEM NO.	PART NO.	DESCRIPTION
1	TX-3003	AC BRACKET
2	421-6592	STICKER ON-OFF
3	421-6950	STICKER MAIN SW
101	509-5131	SW TOGGLE (ET-125A)
102	512-5010	CIRCUIT PROTECTOR NRF 110-8A
103	512-5003	CIRCUIT PROTECTOR 10A (200~240V AREA)
104	600-5577	CABLE & PLUG ASSY W/EARTH
	600-5007	CABLE & PLUG ASSY W/EARTH (240~240V AREA)
105	280-0418	BUSHING STRAIN RELIEF 7.6
106	509-0049	SW STOPPER $\phi 12$
107	270-5009	LINE FILTER (ESD-R-47B)
108	270-5022	NOISE FILTER 20A
109	600-5513	WIRE HARN MOTOR PROTECTOR
110	601-5475	C & R COMB $120\Omega+0.1M$
111	152-0172	CAP FILM 0.47μ 250V
201	010-0408-F	S TITE RH W/F M4x8

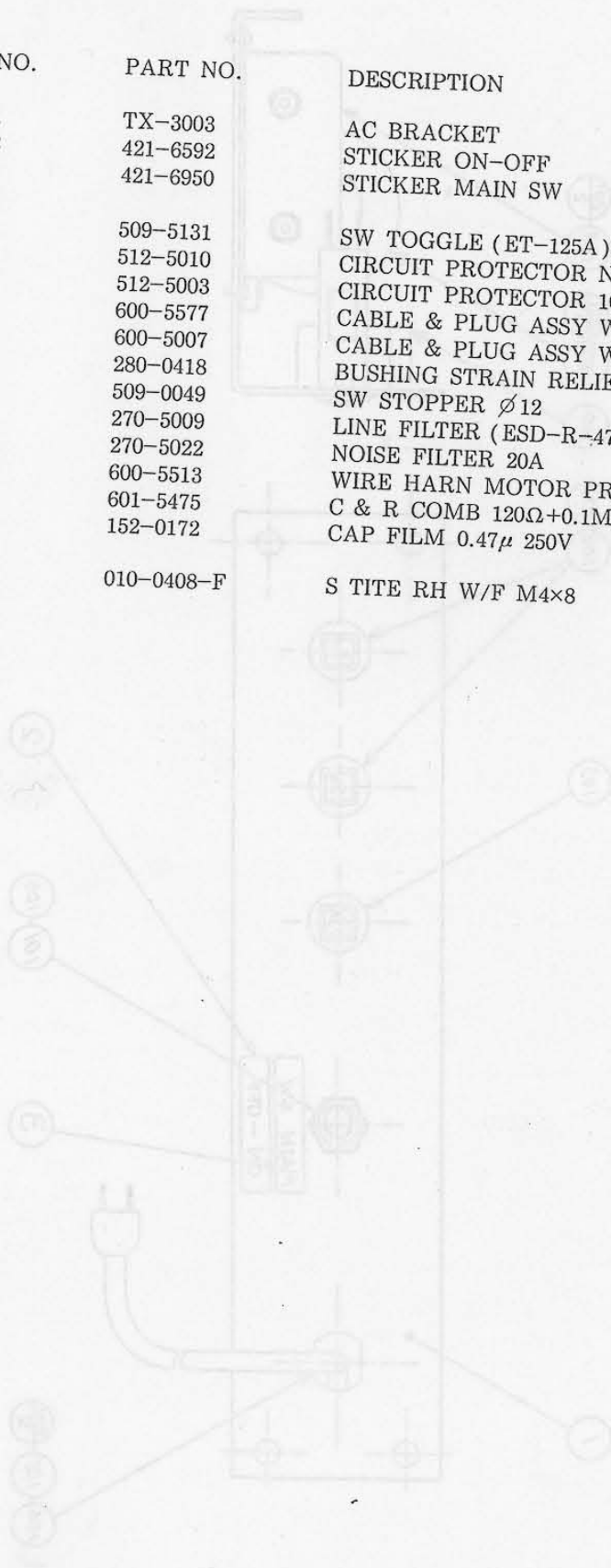

② OUTPUT UNIT TX-3004

ASSEMBLY SW. 9 TX-3004

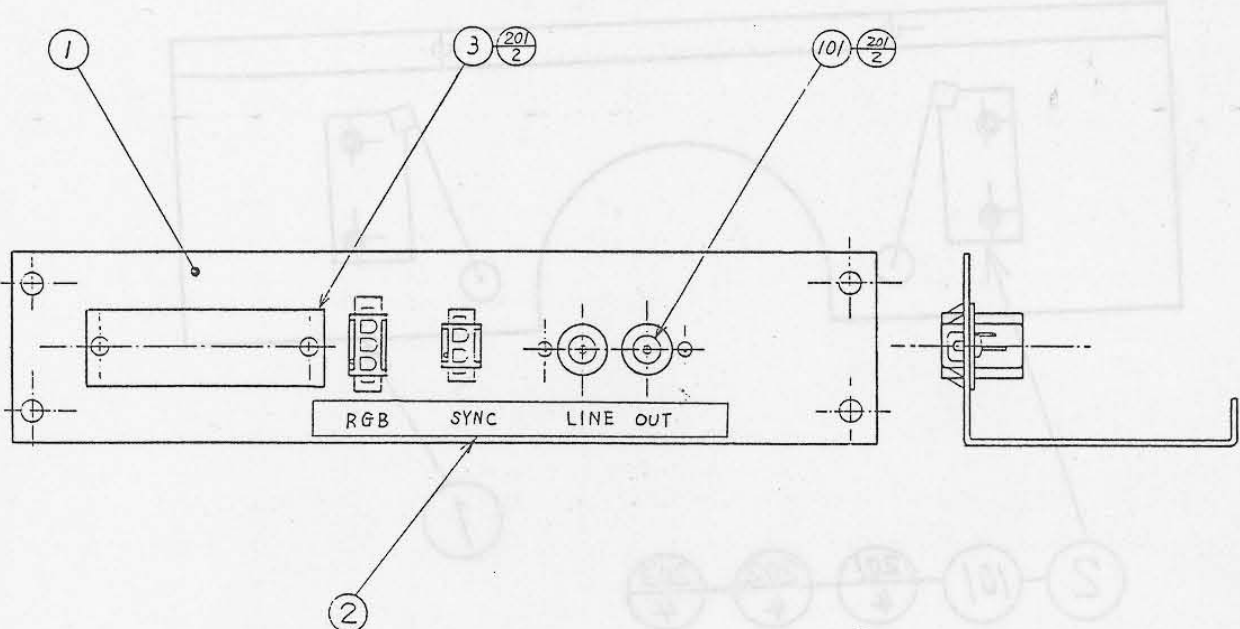

ITEM NO.	PART NO.	DESCRIPTION
1	TX-3005	OUTPUT BRACKET
2	421-6926	STICKER LINE-OUT INSTR
101	210-5019	2P PHONO JACK
201	010-0306	S TITE SCR PH W/F M3×6

② ASSY LIMIT SW. P TX-3012

① OUTPUT UNIT TX-3004

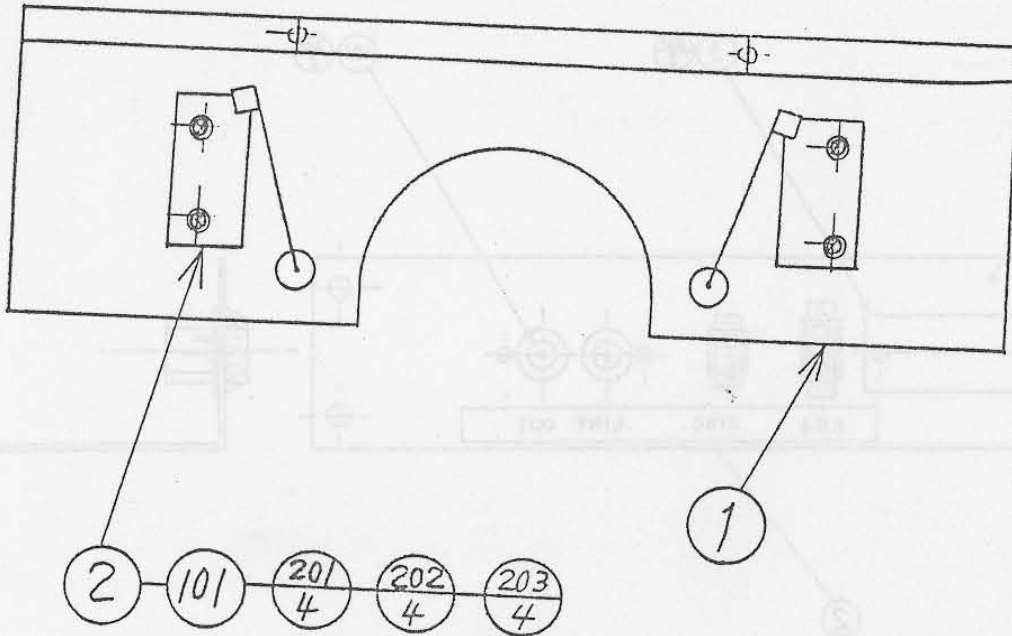

ITEM NO.	PART NO.	DESCRIPTION
1	KR-3013	LIMIT SW BRACKET S
2	KR-3023	LIMIT PLATE
101	509-5199	SW MICRO TYPE
201	000-0430	M SCR P.H M4x30
202	060-0004	FLT WSHR M4
203	061-0004	SPR WSHR M4

② ASSY VR P TX-3014

MOTOR UNIT P TX-3018

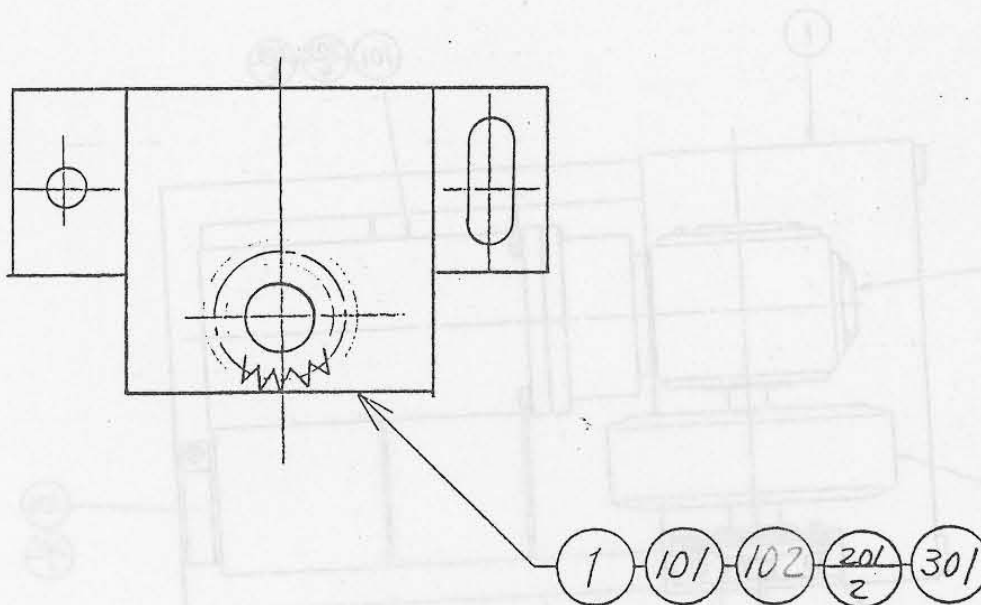

ITEM NO.	PART NO.	DESCRIPTION
1	TX-3015	VR BRACKET P
101	601-5424	GEAR 30
102	220-5130	VOL CONT B KOHM
201	028-0014	SET SCR HEX SKT CP UNBR M4x4

23 MOTOR UNIT P TX-3018

ASSY VR P TX-3018

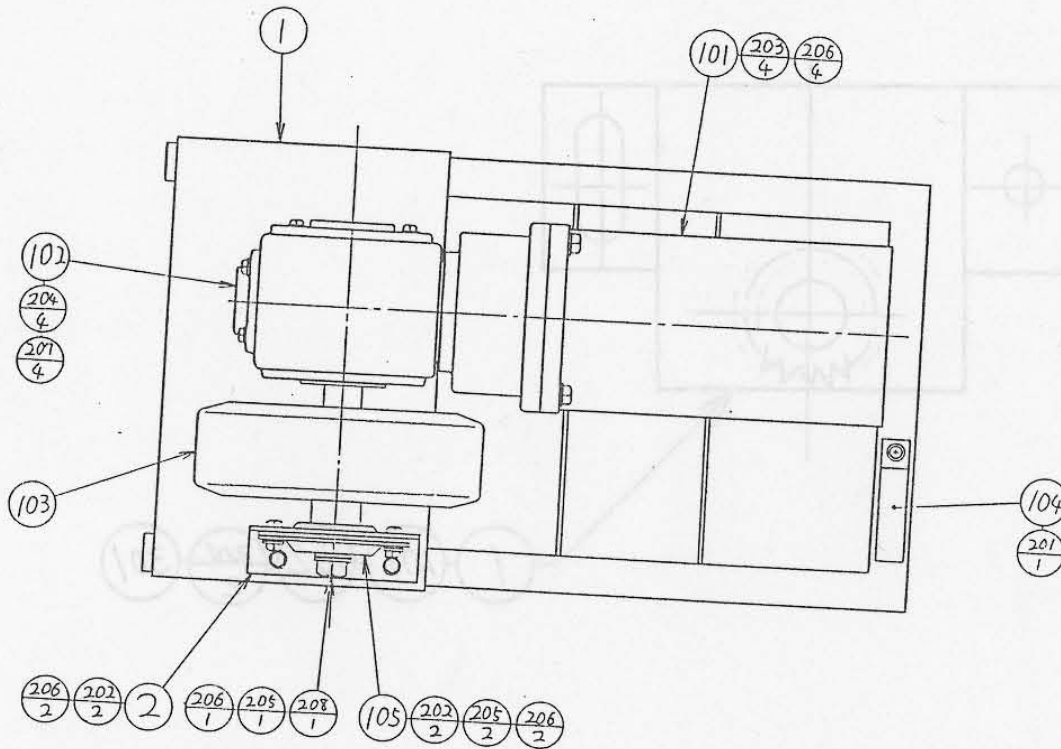

ITEM NO.	PART NO.	DESCRIPTION
1	TX-2032	MOTOR BASE
2	TX-2033	PILLOW BRACKET
101	350-5108	MOTOR DC 80V
102	350-5106	WORM SPEED REDUCER 1/60
103	601-5849	RUBBER WHEEL
104	270-5009	LINE FILTER
105	100-5045	BEARING $\phi 15$
201	010-0410-F	S TITE SCR P.H W/F M4x10
202	030-0620	HEX BLT M6x20
203	030-0625	HEX BLT M6x25
204	030-0820	HEX BLT M8x20
205	060-0006	FLT WSHR M6
206	061-0006	SPR WSHR M6
207	061-0008	SPR WSHR M8
208	030-0610	HEX BLT M6x10

24 ASSY PWR SPLY TX-4000 (D-1/2)

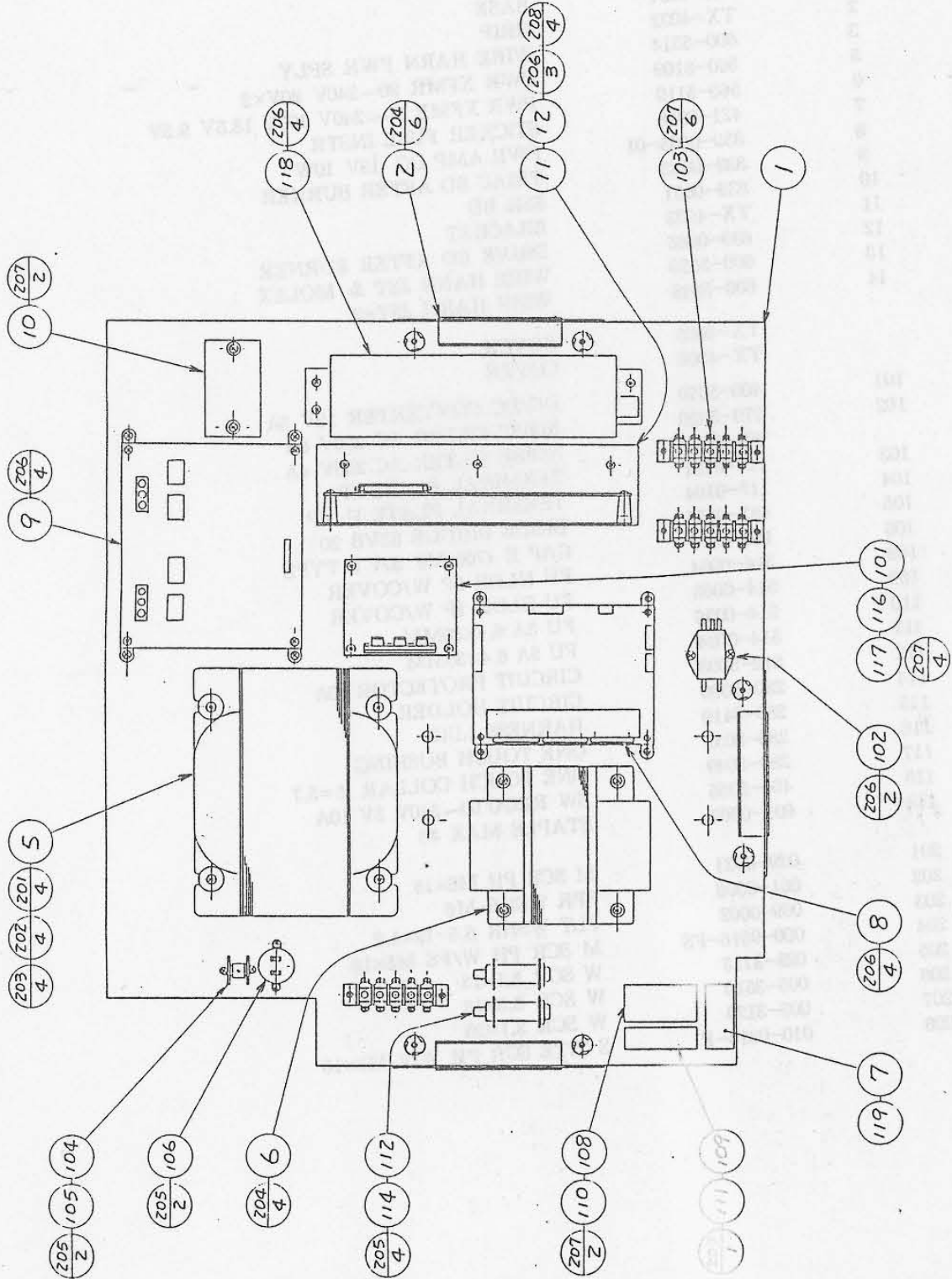

24 ASSY PWR SPLY TX-4000 (D-2/2)

ITEM NO.	PART NO.	DESCRIPTION	PTION
1	TX-4001	BASE	
2	TX-4002	GRIP	
3	600-5514	WIRE HARN PWR SPLY	
5	560-5109	PWR XFMR 90~240V 80V×2	
6	560-5110	PWR XFMR 90~240V 100V 18.5V 9.5V	
7	421-6918	STICKER FUSE INSTR	
8	839-0035-01	PWR AMP DC 12V 10W	
9	839-0083	TRIAC BD AFTER BURNER	
10	839-0051	SSR BD	
11	TX-4003	BRACKET	
12	839-0086	DRIVE BD AFTER BURNER	
13	600-5520	WIRE HARN JST & MOLEX	
14	600-5518	WIRE HARN JST×2	
	TX-4005	COVER	
	TX-4006	COVER	
101	400-5070	DC/DC CONVERTER 12V 5A	
102	270-5020	NOISE FILTER AC 250V 6A	
	601-0429	NOISE FILTER AC 250V 4A	
103	117-5131	TERMINAL PLATE 5P	
104	117-0184	TERMINAL PLATE 1L 4P	
105	481-0157	DIODE BRIDGE S5VB 20	
106	150-0173	CAP E 4700 MF 50V C TYPE	
108	514-0064	FU HLDR 2P W/COVER	
109	514-0065	FU HLDR 1P W/COVER	
110	514-0036	FU 3A 6.4×30MM	
111	514-0034	FU 5A 6.4×30MM	
112	512-5003	CIRCUIT PROTECTOR 10A	
114	280-5096	CIRCUIT HOLDER	
115	280-0419	HARNES LUG	
116	280-5039	ONE TOUCH BUSHING	
117	280-5049	ONE TOUCH COLLAR $\ell=5.7$	
118	400-5055	SW REGU 90~240V 5V 10A	
119	601-0769	STAPLE MAX #3	
201	029-0031	M SCR PH M6×18	
202	061-0006	SPR WSHR M6	
203	069-0002	FLT WSHR 6.5-19×1.2	
204	000-0516-FS	M SCR PH W/FS M5×16	
205	005-3113	W SCR 3.1×13	
206	005-3513	W SCR 3.5×13	
207	005-3120	W SCR 3.1×20	
208	010-0310-F	S TITE SCR PH W/F M3×10	

COIN/CREDIT OPTION SWITCH SETTING

DIP SW A

OPTION		1	2	3	4	5	6	7	8
1 COIN	1 CREDIT	OFF	OFF	OFF	OFF	OFF	OFF	OFF	OFF
1 COIN	2 CREDITS	ON	OFF	OFF	OFF	ON	OFF	OFF	OFF
1 COIN	3 CREDITS	OFF	ON	OFF	OFF	OFF	ON	OFF	OFF
5 COINS	1 CREDIT	ON	ON	OFF	OFF	ON	ON	OFF	OFF
6 COINS	1 CREDIT	OFF	OFF	ON	OFF	OFF	OFF	ON	OFF
7 COINS	1 CREDIT	ON	OFF	ON	OFF	ON	OFF	ON	OFF
2 COINS	1 CREDIT	OFF	ON	ON	OFF	OFF	ON	ON	OFF
3 COINS	1 CREDIT	ON	ON	ON	OFF	ON	ON	ON	OFF
4 COINS	1 CREDIT	OFF	OFF	OFF	ON	OFF	OFF	OFF	ON
2 COINS	3 CREDITS	ON	OFF	OFF	ON	ON	OFF	OFF	ON
2 COINS	1 CREDIT								
3 COINS	2 CREDITS	OFF	ON	OFF	ON	OFF	ON	OFF	ON
5 COINS	3 CREDITS								
6 COINS	4 CREDITS								
2 COINS	1 CREDIT	ON	ON	OFF	ON	ON	ON	OFF	ON
4 COINS	3 CREDITS								
1 COIN	1 CREDIT								
2 COINS	2 CREDITS	OFF	OFF	ON	ON	OFF	OFF	ON	ON
3 COINS	3 CREDITS								
4 COINS	4 CREDITS								
5 COINS	6 CREDITS								
1 COIN	1 CREDIT	ON	OFF	ON	ON	ON	OFF	ON	ON
2 COINS	2 CREDITS								
3 COINS	3 CREDITS								
4 COINS	5 CREDITS								
1 COIN	1 CREDIT	OFF	ON	ON	ON	OFF	ON	ON	ON
2 COINS	3 CREDITS								
NOT USE		ON	ON	ON	ON	ON	ON	ON	ON
COIN SW #1					COIN SW #2				

GAME OPTION SWITCH SETTING

DIP SW B

OPTION		1	2	3	4	5	6	7	8
Moving DX		OFF	OFF						
CABINET MOVING STD		ON	OFF						
TYPE UP RIGHT 1		OFF	ON						
UP RIGHT 2		ON	ON						
THROTTLE WITH				OFF					
LEVER WITHOUT				ON					
SHIPS PER 3 PLAYERS					OFF				
CREDIT 4 PLAYERS					ON				
SHIP INCREASE NO						OFF			
YES						ON			
CONTINUE PLAY NO							OFF		
YES							ON		
GAME DIFFICULTY NORMAL								OFF	OFF
EASY								ON	OFF
HARD								OFF	ON
HARDEST								ON	ON

COIN CHUTE TOWER INSTALLATION PROCEDURE

When the position where the machine is to be put is determined, install the coin chute tower in the following procedure.

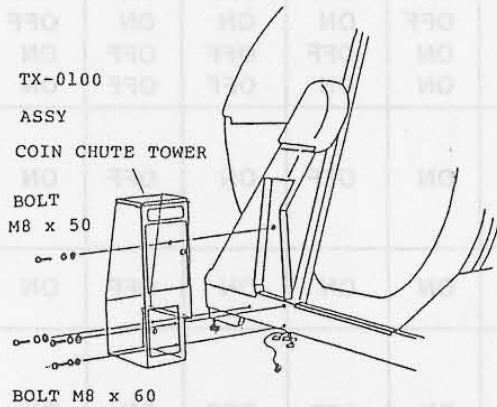

Take out the one (M8 x 50) bolt and 3 (M8 x 60) bolts which are contained in the cashbox.

Mount the coin chute tower on the corner of the base and while holding it, secure it as shown by using the one (M8 x 50) bolt inside the coin chute door and the 3 (M8 x 60) bolts inside the cashbox.

Be careful that no connectors and/or wires are caught in between the coin chute tower and the cabinet & base.

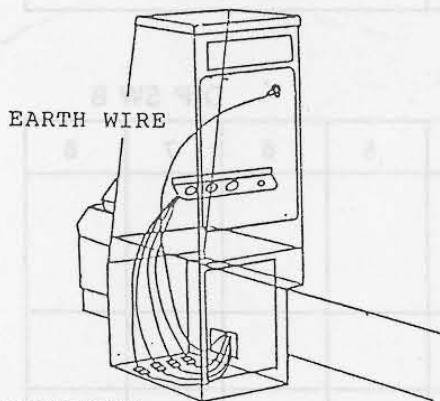

Insert the connectors and earth wire through the cashbox's side hole.

Connect the connectors on the bottom of the cashbox, bring the earth wire up through the cashbox's ceiling hole, and then secure it to any one of the coin chute door screws.

Make sure that the cashbox when inserted and taken out does not catch on the connectors and/or wire.

ROM REPLACEMENT FOR THE AFTER BURNER DELUXE, COMMANDER & UPRIGHT TYPES

(FOR THE PURPOSE OF THROTTLE UNIT INSTALLATION)

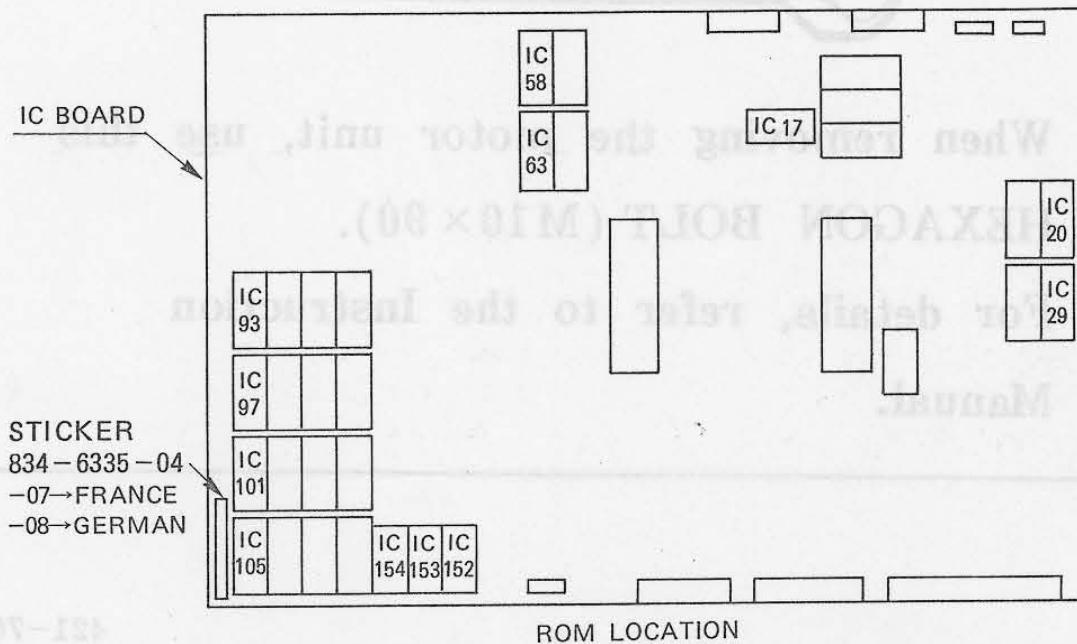

for the change from board number 834-6335-01 (deluxe ,
commander and upright types) to 834-6335-04, -07 & -08:

POSITION	Old ROM	New ROM	
IC 58 (1M)	EPR-11092	EPR-11107	EPR-11171 (FRANCE) EPR-11173 (GERMAN)
IC 63 (1M)	EPR-11093	EPR-11108	EPR-11172 (FRANCE) EPR-11174 (GERMAN)
IC 20 (1M)	EPR-11090	EPR-11109	
IC 29 (1M)	EPR-11091	EPR-11110	
IC 17 (512)	EPR-10923	EPR-11112	
IC 152 (512)	EPR-11087	EPR-11113	
IC 153 (512)	EPR-11088	EPR-11114	
IC 154 (512)	EPR-11089	EPR-11115	
IC 93 (1M)	EPR-11098	EPR-11116	
IC 97 (1M)	EPR-11099	EPR-11117	
IC 101 (1M)	EPR-11100	EPR-11118	
IC 105 (1M)	EPR-11101	EPR-11119	

After the ROM replacements, apply the new board number
834-6335-04, -07 & -08 sticker over the old number
834-6335-01 sticker.

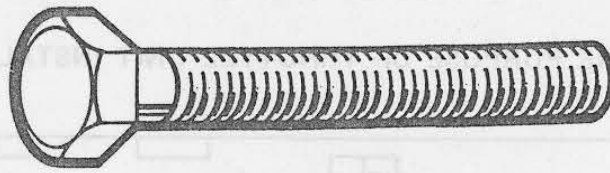

When removing the motor unit, use this
HEXAGON BOLT (M10×90).

For details, refer to the Instruction
Manual.

421-7012-01

POSITION	Old ROM	New ROM
IC 102 (FM)	EPR-1101	EPR-1110
IC 101 (FM)	EPR-1100	EPR-1110
IC 97 (FM)	EPR-1100	EPR-1117
IC 93 (FM)	EPR-1100	EPR-1110
IC 89 (FM)	EPR-1100	EPR-1110
IC 84 (G13)	EPR-1100	EPR-1110
IC 83 (G13)	EPR-1100	EPR-1114
IC 82 (G13)	EPR-1100	EPR-1113
IC 77 (G13)	EPR-1083	EPR-1112
IC 58 (FM)	EPR-1101	EPR-1110
IC 30 (FM)	EPR-1100	EPR-1110
IC 23 (M)	EPR-1103	EPR-1108
IC 28 (FM)	EPR-1103	EPR-1107

After the ROM replacement, apply the new board number
 524-8335-01 sticker over the old number
 524-8335-04 -07 & -08 sticker