

ArcherKit[®]

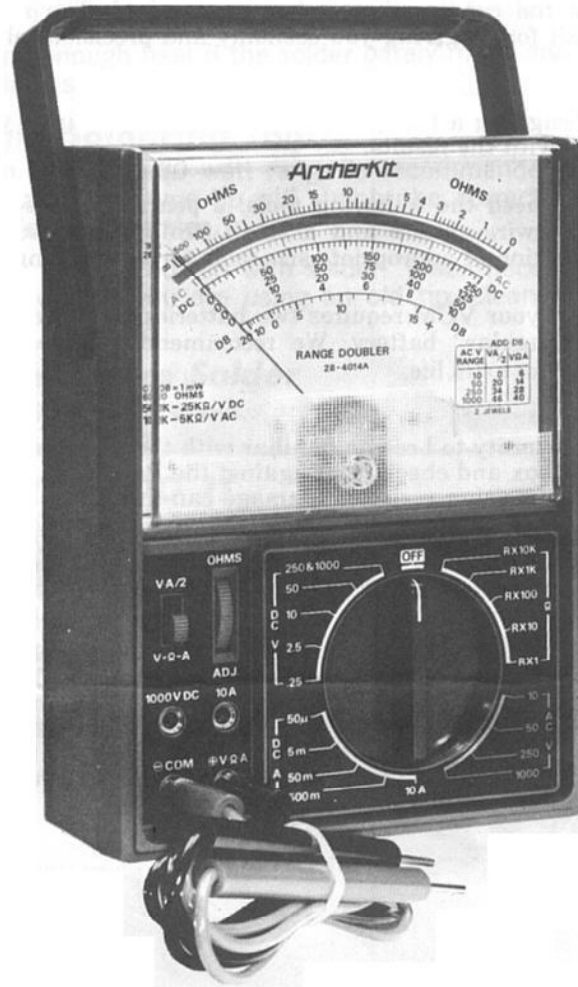

50,000 Ohms-per-Volt VOLT-OHM-METER
Catalog Number 28-4014A

Assembly, Calibration, and User Manual with Parts List

CUSTOM MANUFACTURED FOR RADIO SHACK  A DIVISION OF TANDY CORPORATION

Same as Micronta 22-204 and Sears 82373 multimeters

This Volt-Ohm-Meter is a very sensitive measuring instrument. The VOM is considered to be the most basic test instrument. It is used by Engineers, Technicians, Repairmen, Students and Hobbyists. Almost anyone working with electricity and electronics will constantly be using this type of instrument.

This VOM has been carefully engineered—with the finest meter movement and carefully chosen precision resistors. The result is a superior piece of measuring equipment. We have also given great care to the construction technique required. The result is an ideal high-quality “multitester” in kit form—giving you economy and precision, plus the fun of building your own equipment.

We’ve done our part in designing a fine product. Now, the rest is up to you—build it with care and you’ll be very pleased with the results.

To build this VOM, you’ll need the following tools: a pencil-tipped soldering iron, a pair of long-nose pliers, a pair of wire cutters and a small Phillips-head screwdriver. Your Radio Shack store has a nice selection of appropriate size tools for kit building.

The Resistance function of your VOM requires two batteries for power: one type AA penlight cell and one 9-volt “rectangular” battery. We recommend you use Radio Shack Catalog Number 23-582 and 23-583 for extra life.

UNPACKING

This will give you an opportunity to become familiar with the parts used in your kit. Carefully remove each part from the box and check it off against the Parts List. Take care that you don’t scratch the surface of the precision resistors (damage can affect the accuracy of these parts).

The key to good electronic kit operation is GOOD SOLDERING. The information presented on the facing page will give you instructions on how to make good connections. If you have never soldered before, we urge you to study this information and then practice a little before starting to work on your instrument.

While we’re on the subject of soldering, we’d like to emphasize that the type of soldering iron you use is very important. We’ve already mentioned that it should have a “pencil-type” tip. Also, it should be rated at 30 watts or less. We’d like to strongly recommend that you purchase one of Radio Shack’s **Battery-operated Rechargeable Soldering Irons** (Catalog Number 64-2075). We like to use it personally when building kits because the tip size is almost perfect for this type of work and there is no line cord to drag around on your workbench and get in your way. Try it—we know you’ll like it!



One last thing—don’t rush your work. Take your time and enjoy the fun of building your kit—after all that’s one of the reasons you bought a kit. Also, you do much better work (and enjoy it more) if you take your time.

©Copyright 1974, Radio Shack, A Division of Tandy Corporation, Fort Worth, Texas 76102

THIS KIT MUST BE PROPERLY SOLDERED

USE ENOUGH HEAT

This is the main idea of good soldering. Apply enough heat to the metal surfaces you are joining to make the solder spread freely.

You are not using enough heat if the solder barely melts and forms a rounded ball of rough, flaky solder.

Use the Right Soldering Tool

A soldering iron in the 20-30 watt range is recommended. Any iron in this range with a clean pencil-type tip will supply the correct amount of heat to make a good solder connection.

Keep the iron tip brightly coated with solder. When necessary, wipe the hot iron tip with a cloth. If you are using an old tip, clean it before you start soldering.

Use Only Rosin Core Solder

We supply the right kind of solder.

HERE'S HOW TO DO IT . . .

1. Join bare metal to bare metal. Make good mechanical connections and keep leads as short as possible.
2. Coat the tip of your hot iron with solder. Then **Firmly Press the Tip** against the parts to be soldered.

Apply the solder between the metal to be soldered and the iron tip. Use only enough solder to flow over all surfaces and wires in the connection. Remove the iron.

If you accidentally move the wires as the solder is hardening, apply your iron and reheat.

3. Compare your soldering with these pictures. The connection is good if: solder flowed over all surfaces to be connected, it appears smooth and bright and all wires are held firmly by solder.

You Have Not Used Enough Heat: If your connection is rough and flaky-looking, or if the solder has formed a round ball instead of spreading.

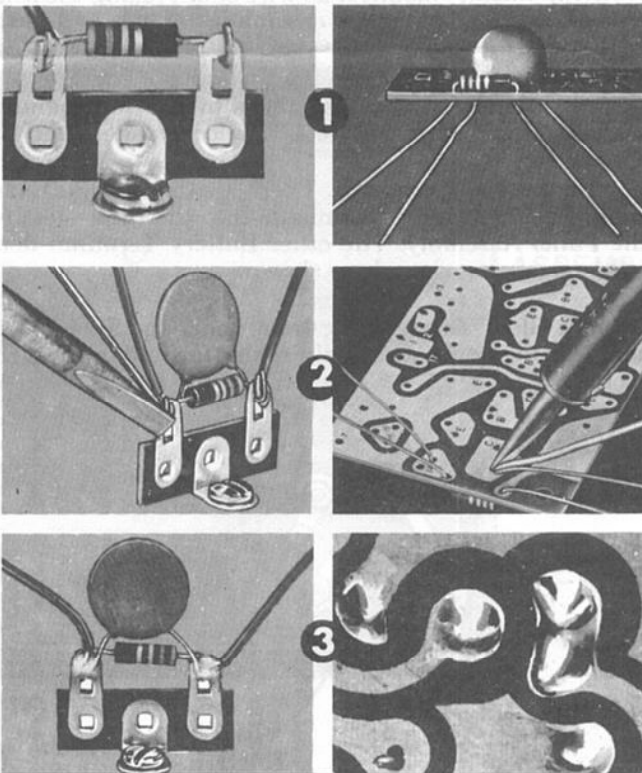

PREPARING YOUR VOM FOR CONSTRUCTION

SEE FIGURE 1.

- Place a soft cloth over your work surface so you don't scratch the Panel Assembly and meter face.
- Remove the Case Back from the Panel Assembly and position the Panel Assembly in front of you as shown.

NOTE: The back of the Meter is covered with a nylon cap. Don't remove this—it is there to keep dust and dirt out of the delicate meter movement.

- Notice that some parts have already been mounted or wired in place. This avoids your having to perform very detailed assembly and soldering work.

NOTE: As you use your soldering iron near and around the plastic case, take great care that it does not touch any of the plastic—the heat can melt the plastic.

- Using the hot tip of your soldering iron to melt the solder in the connection holding the Pink wire to the Small Printed Circuit Board. Release this end of Pink wire. Keep this wire; you'll use it later.
- Carefully remove the calibration resistor R-9 (on a piece of paper, taped to the back of the Meter). Keep the resistor on the paper and install it when called for.
- Locate R-26, wire shunt resistor. It is a loop of wire with an Orange wire soldered to it. Don't bend it out of shape. Refer to Figure 2 for mounting, and use two jack assemblies (10A Jack and \ominus COM Jack) to mount R-26 wire shunt (using the solder lugs already soldered to R-26 for the solder lugs for these Jack assemblies). Put a lockwasher and a nut over each and fasten. The Orange wire will be connected later.
- Mount the other two Jack assemblies to the front panel (referring to Figure 2). Position the solder lugs as shown in Figure 1. Use lockwashers and tighten the nuts securely.
- Locate the Battery Terminals. There are three minus (-) terminals—they each have a dimple. Press the minus Battery Terminals into the three slots (where shown in Figure 1) provided in the Panel Assembly. The other Battery Terminal does not have a dimple in it—press it into the remaining slot where shown.
- There is a Black wire coming from under the Small Printed Circuit Board—its end is positioned near the Jacks. Carefully solder the end to the \ominus COM Jack solder lug.

Figure 2

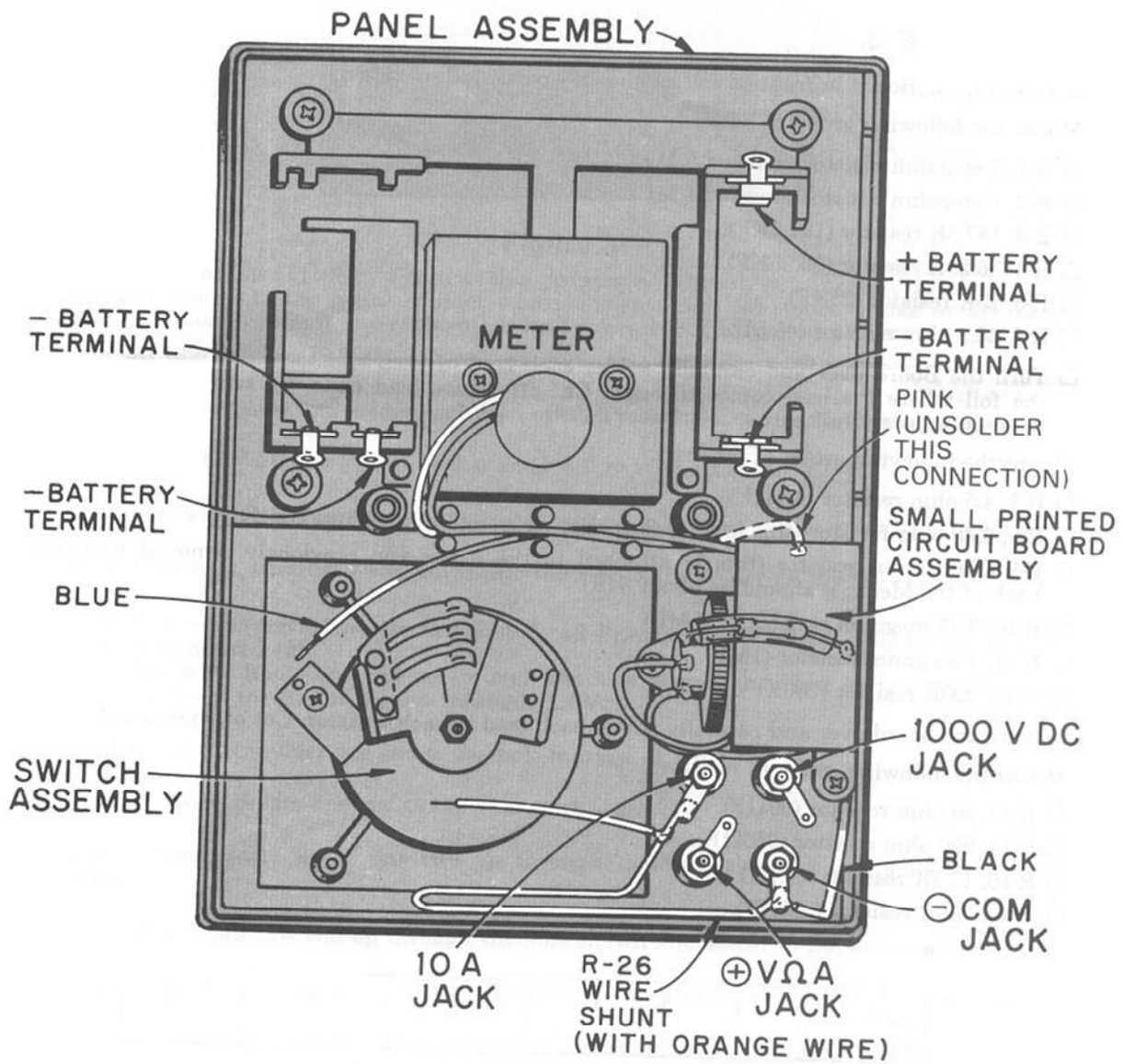
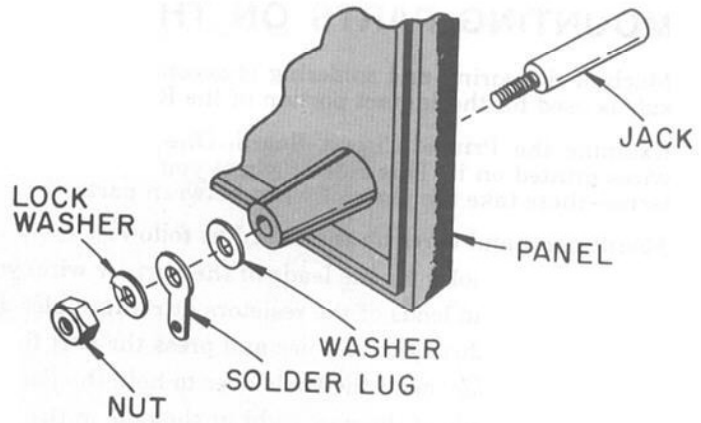

Figure 1

MOUNTING PARTS ON THE PRINTED CIRCUIT BOARD

Much of the wiring and soldering is accomplished on the Printed Circuit Board. Also, the foil side is used for the contact portion of the Range Switch assembly.

Examine the Printed Circuit Board. One side has the outline of resistors and lines for the wires printed on it. This side is where you mount the parts. The other side has metal foil patterns—these take the place of wires between parts.

Mount parts and wires on the Board as follows:

1. Identify the holes for the leads of the part (or wire) you are mounting.
2. Carefully bend leads of the resistors at right angles so they will fit into the Board.
3. Insert leads through the holes and press the part flat down against the Board.
4. On the foil side, bend the leads over to hold the part in place.
5. Solder the leads of the part right at the hole in the foil where the lead comes through.
6. Cut off the excess lead length on the foil side.

SEE FIGURE 3.

- Position the Board in front of you as shown—parts outline side up.

Mount the following group of parts:

- R-1, 5 megohm resistor (marked 5 MF).
- R-2, 1 megohm resistor (marked 1 MF).
- R-3, 187.5K resistor (187.5KF).
- R-4, 56.25K resistor (56.25KF).
- R-5, 25K resistor (25KF).
- R-6, 45.5 ohm resistor (45.5Ω F).
- Turn the Board over and carefully solder each lead of each resistor directly at the hole in the foil where the lead comes through. Cut off excess lead ends. Be sure no solder runs between adjacent foil paths.

Mount the following group of resistors.

- R-7, 4.5 ohm resistor (4.5Ω F).
- R-8, 0.48 ohm resistor (this is a black resistor with silver markings 0.48Ω).
- R-9 Calibration resistor (this is attached to the paper you previously removed from the back of the Meter; it should be about 34K).
- R-10, 3.75 megohm resistor (3.75MF).
- R-11, 1 megohm resistor (1MF).
- R-12, 200K resistor (200KF).
- Turn the board over and carefully solder each lead of each resistor. Cut off excess wire ends.

Mount the following group of resistors:

- R-13, 90 ohm resistor (90Ω F).
- R-14, 950 ohm resistor (950Ω F).
- R-15, 17.7K resistor (17.7KF).
- R-16, 350K resistor (350KF).

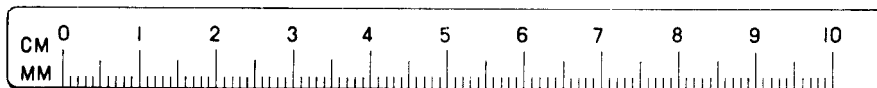

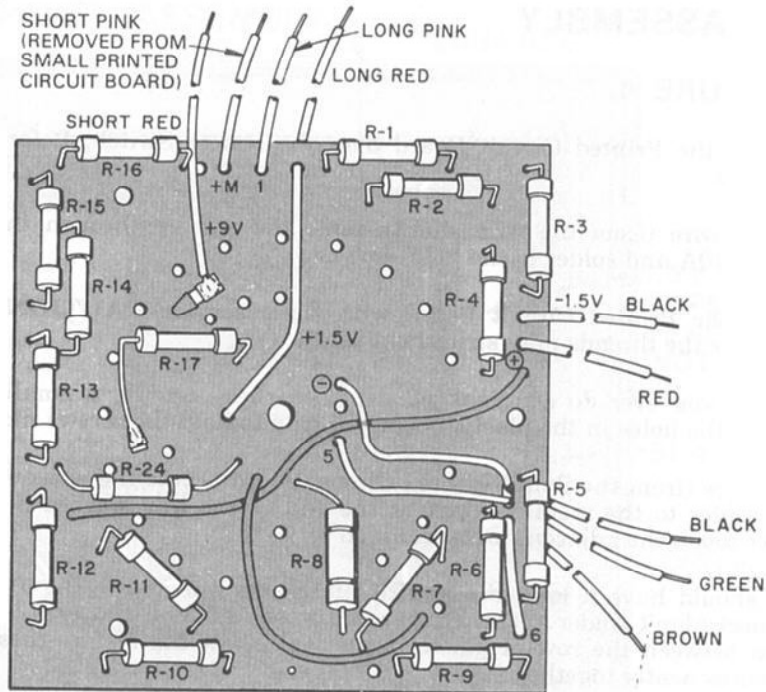

Figure 3

- R-17, 110K resistor (110KF). Position this resistor as shown; cut one lead to about $\frac{3}{4}$ " (2 cm) and solder to the metal contact where shown (don't let solder bridge across to the adjacent metal contact). Insert the other lead down through the hole shown.
 - R-24, 9.5 ohm resistor (9.5Ω).
 - Turn the Board over and solder each lead of each resistor. Cut off excess wire ends.
- Now, continue by adding wires (the other ends will be connected later):
- Short Red wire. Solder one end to the metal contact at the end of the line marked **+9V**.
 - Long Pink wire. Insert one end down into the **1** hole and solder on the foil side.
 - Short Pink wire (previously removed from Small Printed Circuit Board). Solder the free end to the hole marked **+M**.
 - Long Red wire. Route one end up through the hole shown and then solder the end to the hole shown—at the end of the line marked **+1.5V**.
 - Short Black wire. Solder one end to the hole marked **-1.5V**.
 - Short Red wire. Solder one end to the hole marked \oplus .
 - A long Black wire. Route one end up through the hole shown and solder to the hole marked \ominus .
 - Green wire. Route one end up through the hole shown and solder to the hole marked **5**.
 - Brown wire. Route one end up through the hole shown and solder to the hole marked **6**.
 - This completes this sequence of construction on the Printed Circuit Board. Carefully check all your work before you go on. Check especially to be sure excess solder has not flowed across adjacent foil patterns. Also, be sure excess wire ends are cut off so they don't touch adjacent foil paths or connections.

FINAL ASSEMBLY

SEE FIGURE 4.

- Position the Printed Circuit Board over the Range Switch. Before you mount it, do the next step.
- Orange wire (from the wire shunt); route the end up through the hole next to the line marked 10A and solder to the hole shown.
- Mount the Printed Circuit Board with three screws. **CAUTION:** Don't overtighten the screws or the threads may strip the plastic.

NOTE: If you ever do strip the plastic with these screws, a small drop of plastic cement down into the holes in the plastic posts will help to hold the screws nicely.

- Blue wire (from the Small Printed Circuit Board); route the end over the edge of the Board and solder to the metal contact at the end of the line marked **8**. Take care you don't let solder touch the adjacent metal contact.
- You should have a long Black wire left. Solder one end to the 9 Volt Battery - Terminal. Connect (don't solder yet) the other end to the 1.5 Volt Battery - Terminal. Press this wire down between the row of plastic posts just below the Meter—these posts help to keep all the wires neatly together.

Connect the loose ends of wires from the Large Printed Circuit Board as follows:

- Short Red from +9V; solder to the 9 Volt Battery + Terminal.
- Long Pink from 1; solder to foil pattern 1 on the Small Printed Circuit Board.
- Long Red from +1.5V; solder to the 1.5 Volt Battery + Terminal.
- Short Black from -1.5V; solder to the 1.5 Volt Battery - Terminal (there should be 2 wires in this connection).
- Red from \oplus ; connect (don't solder yet) to the +V Ω A Jack.
- Black from \ominus ; solder to \ominus COM Jack (you have already soldered one Black wire to this connection—be sure both wires are firmly held in this connection).
- Green from 5; solder to 5 on the Small Printed Circuit Board.
- Brown from 6; solder to 6 on the Small Printed Circuit Board.
- R-25, 18.75 megohm resistor (18.75 M Ω F). Cut each lead to about $\frac{3}{4}$ " (2 cm). Position the resistor down below the Jack terminals and solder the leads between + V Ω A Jack (2 wires in this connection) and 1000VDC Jack.

This completes the wiring and soldering on your VOM. Before you go on, we suggest you check the following:

1. Check to be sure all leads and wires are soldered.
2. Check to be sure no excess wire ends or solder touches between adjacent foil patterns on the Small Printed Circuit Board.
3. Check to be sure no wire ends or bare leads touch between Jacks.

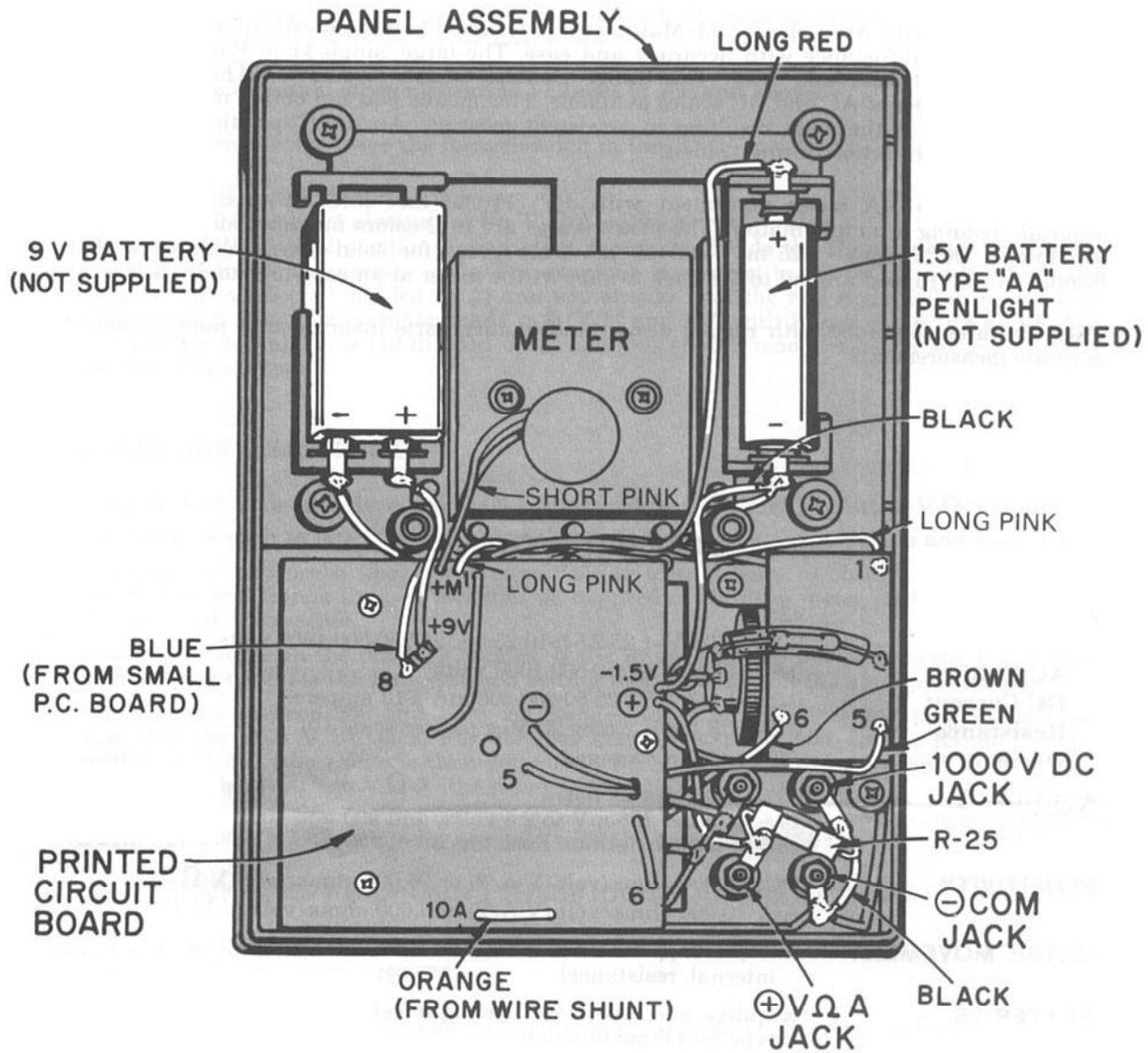

Figure 4

When you are sure everything is OK, install the batteries.

We recommend that you use a Radio Shack TRIPLE LIFE ENERCELL or ALKALINE ENERCELL for the type AA Battery (Catalog Number 23-582 or 23-552). For the 9-volt battery, we suggest either 23-583 or 23-553. These types of batteries will provide longer life, with less chance of leakage or other damaging effects.

Install batteries with polarity as noted.

Fasten the case back in place with the 2 screws provided.

The trim plates on the Panel Assembly (front panel) are covered with vinyl. Remove this protective vinyl (pull up a corner and peel off).

This high-sensitivity ArcherKit VOM/Multitester is designed to measure AC and DC voltages, DC current and Resistance with accuracy and ease. The large, single-knob Range/Function control is easy to use and read. The Range Doubler switch (V-A/2 - V- Ω -A) effectively doubles the number of AC and DC scales available. This means you can obtain meter readings in the upper half of the scale, resulting in consistent accuracy. An "OFF" position is provided to insure meter protection during transit.

The sensitive 18 μ A meter movement with 4¼" (11 cm) face and mirrored scale makes accurate reading a simple matter. The meter scales are in 2 colors for rapid identification. The lowest DC ranges - 125 mV and 25 μ A - are great for solid-state circuit work. The handle can be flipped around to the back to support the meter at an easy-to-read angle.

These features combined with rugged design and quality parts insure you of many years of accurate measurements.

SPECIFICATIONS

RANGES	43
DC Voltage	0-125-250mV-1.25-2.5-5-10-25-50-125-250-500-1000 volts
AC Voltage	0-5-10-25-50-125-250-500-1000 volts
DC Current	0-25-50 μ A-2.5-5-25-50-250-500 mA-5-10 amperes
Resistance	0-2K-20K-200K-2 Meg-20 Meg (center scale 10)
Decibels	-20 to +62 in 8 ranges
ACCURACY	\pm 3% DC except as noted \pm 4% AC, and 125 mV to 2.5 volts, and 500 and 1000 volts DC \pm 3% of scale length on Resistance
SENSITIVITY	DC: 50,000 ohms/volt (V-A/2) or 25,000 ohms/volt (V- Ω -A) AC: 10,000 ohms/volt (V-A/2) or 5,000 ohms/volt (V- Ω -A)
METER MOVEMENT	4¼" (11 cm), 2-color, mirrored scale, 18 μ A full scale (4.2K Ω internal resistance)
BATTERIES	Requires one type "AA" penlight cell and one 9-volt rectangular type for Ohms function
LEADS	47" (120 cm) spring-steel, banana plug style

USING YOUR VOLT-OHM-METER

Be sure you have batteries installed—observe battery polarity.

For most accurate readings, keep the meter laying flat on a non-metallic surface. Also, use a Range and Range Doubler switch setting that results in a reading in the upper 1/3rd of the meter scale.

If the pointer does not normally rest exactly over "0" at the left side of the scale, adjust the plastic screw in the lower center of the meter face to bring the needle to "0".

Always observe correct test lead polarity when making DC measurements: Black into \ominus COM and Red into the \oplus V- Ω -A (or 1000V or 10A) jacks.

Exercise extreme caution when measuring voltages of 150 and above.

When not in use, always leave the Range switch in the "OFF" position.

Use the Range Doubler switch as follows:

For Resistance readings always use the V- Ω -A position.

When using the V-A/2 position for all other functions, divide the Range switch setting by 2 and read on an appropriate scale. For example: Range set to 250 AC V and V-A/2—the range is 125 volts (250 divided by 2) and you should read the **red** scale, following the 0 to 125 markings. Another example: leads in \ominus COM and 10A with Range set to 10A and V-A/2—the range is 5 amperes (10 divided by 2) and you should read the **black** scale, following the 0 to 50 markings.

DC VOLTAGE MEASUREMENTS

1. Plug the test leads into the correct jacks (Black into \ominus COM and Red into \oplus V- Ω -A).
2. Set Range switch to one of the DC V positions; it is best to start at the top and work down.
3. Connect the test probe tips to the circuit under test; be sure to observe correct polarity. Set Range and Range Doubler switches as required to obtain a meter reading in the upper 1/2 or 1/3rd of the scale.
4. Read the voltage on the black DC scales. If the Range Doubler switch is in the V-A/2 position, be sure to divide the Range switch setting by 2 and read on the appropriate scale.
5. For voltages between 250 and 1000, set Range switch to 250&1000 and plug the red test lead into the 1000 V DC jack. For voltages between 250 and 500, set the Range Doubler switch to V-A/2 (the range is then 500 volts). For voltages between 500 and 1000, set the Range Doubler switch to V- Ω -A (the range is then 1000 volts).

NOTE: The 1000 V DC jack is for use only with DC voltages of 250 to 1000.

USE EXTREME CARE WHEN USING THESE HIGH-VOLTAGE RANGES.

AC VOLTAGE MEASUREMENTS

1. Plug the test leads into the correct jacks (Black into \ominus COM and Red into \oplus V- Ω -A).
2. Set Range switch to one of the AC V positions; it is best to start at the top and work down.
3. Connect the test probe tips to the circuit under test. Set Range and Range Doubler switches as required to obtain a meter reading in the upper 1/2 or 1/3rd of the scale.
4. Read the voltage on the red AC scale, following black numbers printed below the red scale. If the Range Doubler switch is in the V-A/2 position, be sure to divide the Range switch setting by 2 and read the appropriate scale.

RESISTANCE MEASUREMENTS

Before taking any resistance measurements, disconnect power to the unit under test and discharge capacitors. It is best to remove batteries and unplug line cords.

1. Plug the test leads into the \ominus COM and \oplus V- Ω -A jacks.
2. Leave the Range Doubler switch in the V- Ω -A position. Set Range switch to one of the Ω positions; touch the test probes together and adjust the OHMS ADJ. control to bring the pointer to the "0" on the OHMS scale (top).

3. Now, connect the probe tips across the circuit or part under test.
4. Read the resistance on the OHMS scale; use the proper multiplier to obtain the correct value (R "times" 1, 10, 100, 1000 or 10,000, depending on the position of the Range switch.).

NOTES: When you are unable to adjust the pointer to "0" on the OHMS scale in the R x 1, R x 10, R x 100 or R x 1K positions, the penlight battery must be replaced.

When you are unable to adjust the pointer to "0" on the OHMS scale when in the R x 10K position, replace the 9-volt battery. When measuring resistance, it is best to disconnect one side of the part under test (thus the remainder of the circuit will not interfere with the readings).

THE RANGE DOUBLER SWITCH MUST BE LEFT IN THE V- Ω -A POSITION FOR ALL RESISTANCE MEASUREMENTS.

DC CURRENT MEASUREMENTS

1. Plug the test leads into the correct jacks (Black into \ominus COM and Red into \oplus V- Ω -A).
2. Set the Range switch to the 500m DC A position (500 milliamp). Or, if the current will be greater than 500 mA, use the 10A jack (instead of the \oplus V- Ω -A) and set Range to 10A. Always start at the top and work down.
3. Open up the circuit in which you want to measure current and connect the black lead to the negative side and the red lead to the positive side of the circuit.
4. Apply power to the circuit under test.
Set Range and Range Doubler switches as required to obtain a meter reading in the upper 1/2 or 1/3rd of the scale.
5. Read the current on the black DC SCALES. If the Range Doubler switch is in the V-A/2 position, be sure to divide the Range switch setting by 2 and read on the appropriate scale.

NOTES: Do not attempt to read AC current.

For currents above 500 milliamps, use the 10A Range switch setting and the 10A jack (instead of the \oplus V- Ω -A jack).

Use the appropriate setting of the Range Doubler switch.

DECIBEL MEASUREMENTS

1. Plug the test leads into the correct jacks (Black into \ominus COM and Red into \oplus V- Ω -A).
2. Set the Range and Voltage Doubler switches as required to obtain a meter reading in the upper 1/2 of the scale.
3. Read dB on the dB scale, adding the appropriate number of dB to the dB scale reading as noted on the chart at the lower right on the meter face.

NOTE: For absolute dB measurements, circuit impedance must be 600 ohms. 0 dB = 1 milliwatt dissipated in a 600 ohm impedance (equivalent to 0.775 volts across 600 ohms).

HOW TO READ THE METER SCALES

The following chart may help you as you read the meter for each range of your VOM.

	Range Setting	Slide Switch		Actual Range	Scale to Read	Each Division Equals
		V Ω A	VA/2			
DC VOLTAGE	.25		x	.125 volt	Black 125	2.5 millivolts
	.25	x		.250 volt	Black 250	5 mV
	2.5		x	1.25 volts	Black 125	25 mV
	2.5	x		2.5 volts	Black 250	50 mV
	10		x	5 volts	Black 50	0.1 volt
	10	x		10 volts	Black 10	0.2 volt
	50		x	25 volts	Black 250	0.5 volt
	50	x		50 volts	Black 50	1 volt
	250 (& 1000)		x	125 volts	Black 125	2.5 volts
	250 (& 1000)	x		250 volts	Black 250	5 volts
250 & 1000 VDC*		x	500 volts	Black 50	10 volts	
250 & 1000 VDC*	x		1000 volts	Black 10	20 volts	
AC VOLTAGE	10		x	5 volts	Black 50**	0.1 volt
	10	x		10 volts	Black 10**	0.2 volt
	50		x	25 volts	Black 250**	0.5 volt
	50	x		50 volts	Black 50**	1 volt
	250		x	125 volts	Black 125**	2.5 volt
	250	x		250 volts	Black 250**	5 volts
	1000		x	500 volts	Black 50**	10 volts
1000	x		1000 volts	Black 10**	20 volts	
RESISTANCE	1	Use only V- Ω -A setting		—	OHMS	Read directly
	10			—	OHMS	Multiply by 10
	100			—	OHMS	Multiply by 100
	1K			—	OHMS	Multiply by 1000
	10K			—	OHMS	Multiply by 10000
DC CURRENT	50 μ A		x	25 μ A	Black 250	0.5 μ A
	50 μ A	x		50 μ A	Black 50	1 μ A
	5 mA		x	2.5 mA	Black 250	50 μ A
	5 mA	x		5 mA	Black 50	100 μ A
	50 mA		x	25 mA	Black 250	0.5 mA
	50 mA	x		50 mA	Black 50	1 mA
	500 mA		x	250 mA	Black 250	5 mA
	500 mA	x		500 mA	Black 50	10 mA
	10A		x	5 Amp	Black 50	100 mA
10A	x		10 Amp	Black 10	200 mA	
DECIBELS	10 Volts AC		x	-20 to +15 dB	Read dB Scale directly	
	10	x		-14 to +21 dB	Add +6 to dB Scale reading	
	50		x	-6 to +29 dB	Add +14 to dB Scale reading	
	50	x		0 to +35 dB	Add +20 to dB Scale reading	
	250		x	8 to +43 dB	Add +28 to dB Scale reading	
	250	x		14 to +49 dB	Add +34 to dB Scale reading	
	1000		x	20 to +55 dB	Add +40 to dB Scale reading	
1000	x		26 to +61 dB	Add +46 to dB Scale reading		

* Using the 250&1000 DC V range, but with the Red + lead connected to the 1000 VDC jack.

** When making AC voltage measurements, read voltage on the RED scale, but you have to follow the **black** numbers which indicate the voltage range.

MAINTENANCE AND CALIBRATION

Your VOM is a very rugged test instrument, so it will withstand a fair amount of abuse—but, don't make it a habit! Take care with it—don't subject it to shock or excessive heat or humidity.

When transporting the VOM, leave the Range Switch set to OFF. This places an electrical short across the meter—effectively damping the movement.

If you don't intend to use the VOM for a few months, remove the batteries. Never leave weak or dead batteries in the VOM.

The calibration pots have been preset at the factory for most precise readings. They never need to be reset unless major changes are made in shunt and/or multiplier resistors. If you have precision calibration equipment, you can check and adjust calibration as follows:

NOTE: VR-1, 2, 3 and 4 are on the small PCB and are marked 1, 2, 3 and 4 (1 is closest to the Jacks).

Step	Calibration Input	Range Setting	Range Doubler	Adjust
1.	50 volts DC	50 DC V	V- Ω -A	VR-4
2.	25 volts DC	50 DC V	V-A/2	VR-3
3.	50 volts DC	50 DC V	V- Ω -A	VR-4
4.	25 volts DC	50 DC V	V-A/2	VR-3
5.	25 mA DC	50m DC A	V-A/2	VR-2
6.	125 volts AC	250 AC V	V-A/2	VR-1

PARTS LIST

Symbol	Description	Part Number
DIODES		
D-1	Germanium diode (TC2050A or Equiv.)	
D-2	Silicon diode (1S1146S or Equiv.)	
D-3	Silicon diode (1S1146S or Equiv.)	
D-4	Silicon diode (1S1146S or Equiv.)	

RESISTORS

All resistors are 1/4-watt, 1%, unless otherwise noted.

R-1	5 meg
R-2	1 meg
R-3	187.5K
R-4	56.25K
R-5	25K
R-6	45.5 ohms
R-7	4.5 ohms
R-8	0.48 ohms, wire-wound
R-9	34K calibration resistor (value may vary from unit to unit)
R-10	3.75 meg
R-11	1 meg
R-12	200K
R-13	90 ohms
R-14	950 ohms
R-15	17.7K
R-16	350K

R-17	110K	
R-18	10K, 1/4-watt (mounted)	
R-19	5K, 1/4-watt (mounted)	
R-20	15K, 1/4-watt (mounted)	
R-21	22K, 1/4-watt (mounted)	
R-22	1K, 1/4-watt (mounted)	
R-23	6.65K, 1/4-watt (mounted)	
R-24	9.5 ohm	
R-25	18.75 meg. 1/2-watt	
R-26	0.025 ohm wire shunt (with orange wire and lugs attached)	
VR-1	5K semi-adjustable resistor, VAC Cal (mounted and pre-set)	P-0755
VR-2	3K semi-adjustable resistor, Current Cal (mounted and pre-set)	P-0756
VR-3	3K semi-adjustable resistor, DCV Cal (mounted and pre-set)	P-0757
VR-4	5K semi-adjustable resistor, DCV Cal (mounted and pre-set)	P-0758
VR-5	10K variable resistor, OHMS ADJ (mounted)	P-0759

SWITCH

S-1	Range Doubler, slide switch (mounted)	S-2233
-----	---------------------------------------	--------

MISCELLANEOUS

Description	Quantity	Part Number
Battery terminals, -	3	HB-1023
Battery terminal, +	1	HB-1024
Case back	1	Z-1963
Jacks	4	J-4354
Knob, OHMS ADJ	1	K-1628
Nut	4	HN-0245
Panel assembly with Meter *	1	M-0445
Printed Circuit Board, large	1	X-4758
Printed Circuit Board, small (mounted)	1	X-4759
Screw, medium, for Printed Circuit Board	3	HS-1581
Screw, long, for case	1	HS-1582
Solder	1 length	
Solder lug, for Jacks	2	HB-1025
Test leads	1 pair	W-1724
Washer, flat metal (for Jacks)	4	HW-0825
Washer, lock (for Jacks)	4	HW-0826
Wire:		
Black, short		HB-1026
Black, long (2)		HB-1027
Brown		HB-1028
Red, short (2)		HB-1029
Red, long		HB-1030
Green		HB-1031
Pink, Long		HB-1032

* Replacement window face (only) for Meter can be ordered under part number G-0160.

The resistors in your kit may be color-coded for value and tolerance instead of numerical markings. In this case, use the following chart to identify the resistors. Keep it handy and always refer to it when you mount the resistors.

REF. NO.	VALUE	COLOR CODE
R-1	5M Ω	GREEN, BLACK, BLACK, YELLOW, BROWN
R-2	1M Ω	BROWN, BLACK, BLACK, YELLOW, BROWN
R-3	187.5 K	BROWN, GRAY, GRAY, ORANGE, BROWN
R-4	56.25 K	GREEN, BLUE, ORANGE, RED, BROWN
R-5	25 K	RED, GREEN, BLACK, RED, BROWN
R-6	45.5 Ω	YELLOW, GREEN, GREEN, GOLD, BROWN
R-7	4.5 Ω	YELLOW, GREEN, BLACK, SILVER, BROWN
R-10	3.75M Ω	ORANGE, VIOLET, GREEN, YELLOW, BROWN
R-11	1M Ω	BROWN, BLACK, BLACK, YELLOW, BROWN
R-12	200 K	RED, BLACK, BLACK, ORANGE, BROWN
R-13	90 Ω	WHITE, BLACK, BLACK, GOLD, BROWN
R-14	950 Ω	WHITE, GREEN, BLACK, BLACK, BROWN
R-15	17.7 K	BROWN, VIOLET, VIOLET, RED, BROWN
R-16	350 K	ORANGE, GREEN, BLACK, ORANGE, BROWN
R-17	110 K	BROWN, BROWN, BLACK, ORANGE, BROWN
R-18	10 K	BROWN, BLACK, BLACK, RED, BROWN
R-19	5 K	GREEN, BLACK, BLACK, BROWN, BROWN
R-20	15 K	BROWN, GREEN, BLACK, RED, BROWN
R-21	22 K	RED, RED, BLACK, RED, BROWN
R-22	1 K	BROWN, BLACK, BLACK, BROWN, BROWN
R-23	6.65 K	BLUE, BLUE, GREEN, BROWN, BROWN
R-24	9.5 Ω	WHITE, GREEN, BLACK, SILVER, BROWN
R-25	18.75M Ω	BROWN, GRAY, GRAY, GREEN, BROWN

SI: V-Ω-A V-A/2

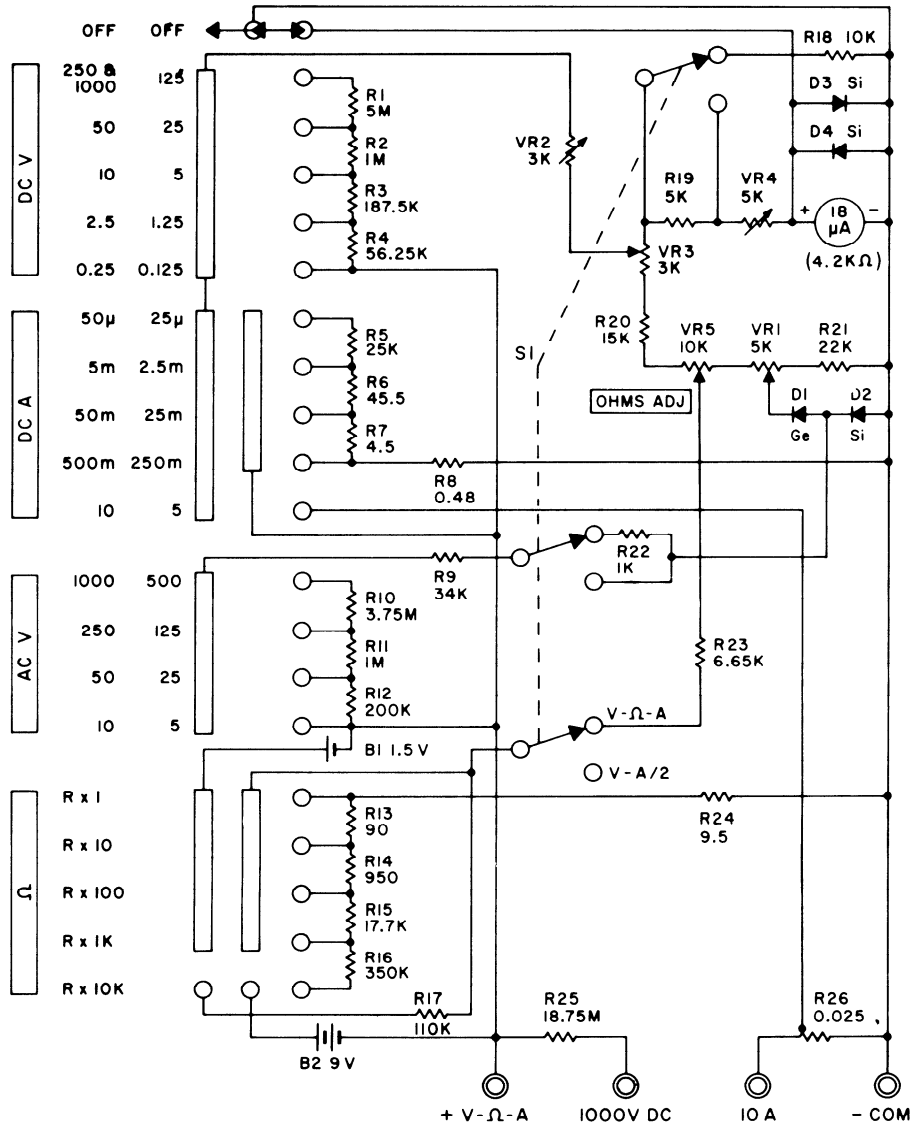

NOTE: RESISTANCE IS IN OHMS; K = x 1000, M = x 1000K
 Si = Silicon
 Ge = Germanium

SCHEMATIC DIAGRAM

ARCHERKIT LIMITED WARRANTY AND SERVICE INFORMATION

50,000 OHMS/VOLT VOLT-OHM-METER

PARTS WARRANTY

Every Archerkit is warranted for a period of ninety (90) days from date of purchase, against defects in material and workmanship.

Prompt, no charge replacement of defective parts will be made. We reserve the right to request the return of any defective part prior to replacement.

Parts which, in our judgment, have been misused or otherwise damaged during construction are not covered by terms of this warranty.

IN WARRANTY REPAIR SERVICE

Within 90 days from the date of purchase you may return your completed Archerkit for repair and adjustment to your store for a minimum service and handling charge of \$5.00.

Kits not completely wired or which require extensive rework to make them operable, will be subject to a charge for labor at the rate of \$7.50 per hour plus the cost of any parts required. You will be notified of the amount of any such extra charge prior to repairing your unit.

Unit not constructed in accordance with the assembly instructions, modified in any way, or show evidence of misuse, neglect or accident or indicate that acid core solder has been used will be returned unrepaired at the owner's expense.

OUT OF WARRANTY SERVICE

Radio Shack maintains complete service facilities for all its products. If service is required, follow the instructions given at the right. Repair charges will be for the cost of material, plus \$7.50 per hour for service time.

We reserve the privilege of making revisions in current production and assume no obligation to incorporate these changes in earlier models.

The preceding Warranty and Service policy applies only to the original purchaser. Radio Shack assumes no liability for consequential damages, or other losses incurred by the buyer in connection with the purchase, construction or operation of any Archerkit product. This Warranty gives you specific legal rights and you may also have other rights which vary from state to state.

IMPORTANT INSTRUCTIONS

1. If your unit is not working properly, first take your kit to the store where it was purchased for assistance.
2. If your kit is missing parts write to our National Parts Center. Be sure to include:
 - a. The stock number which appears on the manual and carton.
 - b. Date of purchase.
 - c. Store from which it was purchased.
 - d. Exact description and part number of missing parts.

For Technical Assistance and Service:

The store where you purchased this kit.

For Parts:

National Parts Center
Radio Shack
1800 South Beach Street
Fort Worth, Texas 76105

RADIO SHACK  **A DIVISION OF TANDY CORPORATION**

U.S.A.: FORT WORTH, TEXAS 76102
CANADA: BARRIE, ONTARIO L4M 4W5

TANDY CORPORATION

AUSTRALIA

280-316 VICTORIA ROAD
RYDALMERE, N.S.W. 2116

BELGIUM

PARC INDUSTRIEL DE NANINNE
5140 NANINNE

U. K.

BILSTON ROAD, WEDNESBURY
WEST MIDLANDS WS10 7JN

CATALOG NO: 28-4014A

11A9

Printed in Korea