

16-564-101
FEBRUARY 1988

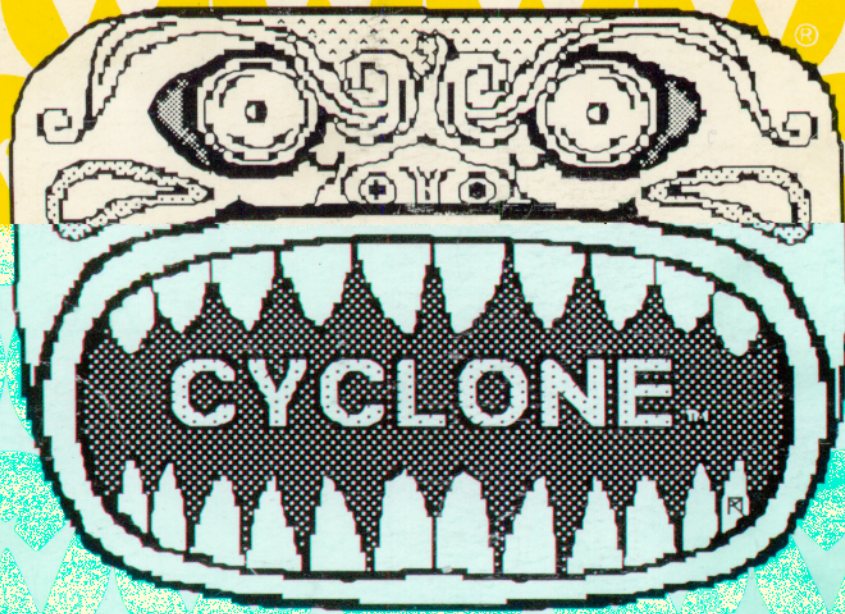

OPERATIONS MANUAL
including
**TEST/DIAGNOSTIC
PROCEDURES,
REFERENCE INFORMATION,
&
SCHEMATICS**

Williams[®] 
ELECTRONICS GAMES, INC.

CYCLONE ROM and Jumper Table

| Game | System 11B CPU Rev. | P/N - U15 Game μP | P/N - U27 G. ROM 1 | P/N - U26 G. ROM 2 | P/N - U21 S. ROM 1 | P/N - U22 S. ROM 2 | P/N - U24 Sound μP | Jumpers |
|---------------|---------------------|-------------------|--------------------|--------------------|--------------------|--------------------|--------------------|---|
| BIG GUNS | - | 5400-09150-00 | A-5343-557-2 | A-5343-557-1 | A-5343-557-4 | A-5343-557-3 | 5400-09150-00 | W1, 2, 4, 5, 7, 8, 11, 14, 16, 17, and 19 |
| SPACE STATION | - | ↓ | A-5343-552-2 | A-5343-552-1 | A-5343-552-4 | A-5343-552-3 | | W1, 2, 4, 5, 7, 8, 11, 14, 16, 17, and 19 |
| CYCLONE | - | ↓ | A-5343-564-2 | A-5343-564-1 | A-5343-564-4 | A-5343-564-3 | ↓ | W1, 2, 4, 5, 7, 8, 11, 14, 16, 17, and 19 |

CYCLONE Solenoid Table

| Sol. No. | Solenoid Description <small>p = Playfield b = Backglass</small> | Solenoid Type | Wire ¹ Color | Connections | | Driver Trans. | Solenoid Part Number Flashlamp Type | |
|------------------|--|---------------|-------------------------|-------------|---|---------------|--|---------------|
| | | | | CPU Bd. | Playfield/ Cabinet | | b = Backbox | p = Playfield |
| 01A ³ | Outhole Kicker | Switched | {Vio-Brn} | 1P11-1 | 8P3-1 (via 5J1-9, Aux Pwr Drvr Bd.) | Q33 | AE-23-800 | |
| 01C ³ | L F Wheel (p) & Jackpot (b) Flashers | Switched | {Blk-Brn} | (Gry-Brn) | | Q33 | #89 flashlamps | 2b, 1p |
| 02A ³ | | Switched | {Vio-Red} | 1P11-3 | 8P3-2 (via 5J1-7, Aux Pwr Drvr Bd.) | Q25 | | |
| 02C ³ | R F Wheel (p) & Teeth (b) Flashers | Switched | {Blk-Red} | (Gry-Red) | | Q25 | #89 flashlamps | 1b, 1p |
| 03A ³ | Ball Shooter Kickbig | Switched | {Vio-Orn} | 1P11-4 | 8P3-3 (via 5J1-6, Aux Pwr Drvr Bd.) | Q32 | AE-24-900 | |
| 03C ³ | Top mid (p) & L Eye (b) Flashers | Switched | {Blk-Orn} | (Gry-Orn) | | Q32 | #89 flashlamps | 1b, 1p |
| 04A ³ | Boomerang Kickbig | Switched | {Vio-Yel} | 1P11-5 | 8P3-4 (via 5J1-5, Aux Pwr Drvr Bd.) | Q24 | AE-26-1500 | |
| 04C ³ | Cats (p) & lwr Fireworks (b) Flashers | Switched | {Blk-Yel} | (Gry-Yel) | | Q24 | #89 flashlamps | 1b, 2p |
| 05A ³ | Drop Target | Switched | {Vio-Grn} | 1P11-6 | 8P3-5 (via 5J1-4, Aux Pwr Drvr Bd.) | Q31 | AE-23-800 | |
| 05C ³ | Ducks (p) & R Fireworks (b) Flashers | Switched | {Blk-Grn} | (Gry-Grn) | | Q31 | #89 flashlamps | 1b, 2p |
| 06A ³ | | Switched | {Vio-Blu} | 1P11-7 | 8P3-6 (via 5J1-3, Aux Pwr Drvr Bd.) | Q23 | | |
| 06C ³ | Ferris Wheel (p) Flashers | Switched | {Blk-Blu} | (Gry-Blu) | | Q23 | #89 flashlamps | 2p |
| 07A ³ | Knocker /Ticket Dispenser (b'box) | Switched | {Vio-Blk} | 1P11-8 | 8P3-7 (via 5J1-2, Aux Pwr Drvr Bd.) | Q30 | AE-26-1200 | |
| 07C ³ | Cyclone (p) & R Eye (b) Flashers | Switched | {Blk-Vio} | (Gry-Vio) | | Q30 | #89 flashlamps | 1b, 1p |
| 08A ³ | | Switched | {Vio-Gry} | 1P11-9 | 8P3-8 (via 5J1-1, Aux Pwr Drvr Bd.) | Q22 | | |
| 08C ³ | Spook H'se (p) & L Fworks (b) Flashers | Switched | {Blk-Gry} | (Gry-Blk) | | Q22 | #89 flashlamps | 1b, 1p |
| 09 | Spook House Bonus Flasher (p) | Contrl'd | Brn-Blk | 1P12-1 | 8P3-9 (via 5J2-9) | Q17 | #89 flashlamps | 1p |
| 10 | Playfield Gen Illumin Relay (p) | Contrl'd | Brn-Red | 1P12-2 | 8P3-10 (via 5J2-8) | Q9 | 5580-09555-01 ⁴ | |
| 11 | Backglass Gen Illumin Relay (b) | Contrl'd | Brn-Orn | 1P12-4 | 6J3-1 (via 5J2-6) | Q16 | 5580-09555-01 ⁴ | |
| 12 | Solenoid A/C Select Relay (b) | Contrl'd | Brn-Yel | 1P12-5 | 8P3-12 (via 5J2-5) | Q8 | 5580-09555-01 ⁵ | |
| 13 | Mystery Wheel (b) Coil B | Contrl'd | Brn-Grn | 1P12-6 | 6J2-3 (B'box Conn Bd) | Q15 | 14-7948/D-12045 | |
| 14 | Mystery Wheel (b) Coil A | Contrl'd | Brn-Blu | 1P12-7 | 6J2-4 | Q7 | 14-7948/D-12045 | |
| 15 | Boomerang Flashers (p) | Contrl'd | Brn-Vio | 1P12-8 | 8P3-15 (via 5J2-2) | Q14 | #1251 lamps | 3p |
| 16 | Ferris Wheel Motor/Relay (p) | Contrl'd | Brn-Gry | 1P12-9 | 8P3-16 (via 5J2-1) | Q6 | 14-7941-3/5580-12145-01 ⁶ | |
| 17 | Left Jet Bumper | Spec'l #1 | Blu-Brn | 1P19-7 | 8P3-17 (via 5J3-7) | Q75 | AE-23-800 | |
| 18 | Left Kicker ("sling") | Spec'l #2 | Blu-Red | 1P19-4 | 8P3-18 (via 5J3-6) | Q71 | AE-26-1500 | |
| 19 | Right Jet Bumper | Spec'l #3 | Blu-Orn | 1P19-3 | 8P3-19 (via 5J3-3) | Q73 | AE-23-800 | |
| 20 | Right Kicker ("sling") | Spec'l #4 | Blu-Yel | 1P19-6 | 8P3-20 (via 5J3-4) | Q69 | AE-23-800 | |
| 21 | Bottom Jet Bumper | Spec'l #5 | Blu-Grn | 1P19-8 | 8P3-21 (via 5J3-2) | Q77 | AE-26-1500 | |
| 22 | | Spec'l #6 | Blu-Blk | 1P19-9 | | Q79 | | |
| - | Right Flipper | - | Orn-Vio [Blu-Vio] | 1P19-1 | 7P1-15 [7P1-16, 8P3-34] ² | - | FL11630-50VDC | |
| - | Left Flipper | - | Orn-Gry [Blu-Gry] | 1P19-2 | 7P1-18 [7P1-19, 8P3-32] ² | - | FL11630-50VDC | |

Notes: 1. Wire colors, except flipper Orn-Vio and Orn-Gry, are ground connections (to coil terminal with unbanded end of diode). Flipper Orn-Vio and Orn-Gry wires connect from CPU Board to flipper switch. 2. Flipper connections shown in braces are from flipper switch to flipper coil. 3. "A" coils are pulsed, when Sol. 12 is de-energized; "B" coils are pulsed, with Sol. 12 energized. Wire colors in brackets are those from respective A and B terminals corresponding to the J1- terminal connection listed for the Aux Power Driver Bd., which controls the device pulsing by Sol. 12. 4. Relay is mounted on Relay Bd. p/n C-11998-1. 5. Relay is mounted on Aux Pwr Driver Bd. D-11813 in the backbox. 6. Relay is mounted on Relay Bd C-11902-1.

Contents

Section 1 - Game Operation & Test Information

| | |
|--|-----|
| <i>CYCLONE</i> (System 11B) ROM Summary | 1 |
| Connector Identification | 2 |
| <i>CYCLONE</i> Circuit Boards | 2 |
| <i>CYCLONE</i> Game Control Locations | 2 |
| Pinball Game Assembly Instructions | 3 |
| Figure 1. Pinball Assembly, Playfield Pitch Angle, and Leg Leveler Details | 3 |
| Game Operation | 4 |
| <i>CYCLONE</i> Game Status Displays | 6 |
| <i>CYCLONE</i> Audit Table | 7 |
| <i>CYCLONE</i> Game Adjustment Table | 8-9 |
| Game Adjustment Procedure | 10 |
| Items 01 - 05. | 11 |
| 06 - 11. | 12 |
| 12 - 17. | 13 |
| 18 - 25. | 14 |
| 26 - 34. | 15 |
| 35 - 41. | 16 |
| 42 - 48. | 17 |
| 49 - 52. | 18 |
| 53 - 54. | 19 |
| 55 - 58. | 20 |
| 59 - 63. | 21 |
| 64 - 70. | 22 |
| <i>CYCLONE</i> Game Adjustment Setting Comparison Table | 23 |
| Resetting the High Scores. | 24 |
| Game Pricing | 24 |
| <i>CYCLONE</i> Pricing Table. | 25 |
| Test/Diagnostic Procedures. | 26 |
| Music Test. | 26 |
| Display Test. | 26 |
| Sound Test. | 26 |
| Lamp Tests | 27 |
| <i>CYCLONE</i> Lamp-Matrix Table | 27 |
| Solenoid Test | 28 |
| <i>CYCLONE</i> Solenoid Table | 28 |
| Special and Controlled Solenoids - Diagrams and Details | 29 |
| Figure 2. Typical Solenoid A/C Select Relay Circuit. | 29 |
| Switch Tests | 30 |
| <i>CYCLONE</i> Switch-Matrix Table. | 30 |
| Ending the Diagnostic Tests | 31 |
| Mystery Wheel Test. | 31 |
| Auto Burn-in Mode | 32 |
| System-11B Memory Chip Test | 32 |
| CPU LED Indicator Codes Table | 32 |
| System-11B Sound Circuitry Tests | 33 |
| Fuse Listing. | 34 |

Contents

Section 2 - Reference Diagrams & Schematics

| | |
|---|--------|
| Switches Locations. | 36 |
| Switch Circuitry, Typical Switch Circuit, and Matrix Diagram. | 37 |
| Lamp Circuitry, Typical Lamp Circuit, and Matrix Diagram | 38 |
| Lamps. | 39 |
| Solenoids/Flashers & Rubber Parts. | 40 |
| Playfield Circuit Boards & Major Devices Locations | 41 |
| Cabinet Wiring Diagram | 42 |
| D-8345-557 Power Supply Schematic | 43 |
| Aux Power Driver Board (D-11813) & Schematic. | 44- 45 |
| Audio Board Schematic | 46 |
| Alphanumeric Display Unit Board Schematic | 47 |
| Interboard Signals Diagrams | 48 |
| Schematic, System 11B CPU (16-9019, Sheet 1 of 4). | 49 |
| Schematic, System 11B CPU (16-9019, Sheet 2 of 4). | 50 |
| Schematic, System 11B CPU (16-9019, Sheet 3 of 4). | 51 |
| Schematic, System 11B CPU (16-9019, Sheet 4 of 4). | 52 |
| Controlled, Special, and Switched Solenoids | 53 |
| Power Wiring Diagram | 54 |
| Diagnostic Test Flowchart (Side 1) | 55 |
| Diagnostic Test Flowchart (Side 2) | 56 |

Section 1

Game Operation & Test Information

- **CYCLONE (System 11B) ROM Summary**
- **Pinball Game Assembly Instructions**
- **Game Play**
- **Game Status Displays**
- **Game Adjustment Procedure**
- **Game Pricing**
- **Test/Diagnostic Procedures**

CYCLONE (System 11B) ROM Summary

| IC | DESCRIPTION | TYPE | IDENTIFIER | BOARD | PART NUMBER |
|--------------------|-------------|-------|------------|-------|--------------|
| Game ROM 1 | 32K x 8 ROM | 27256 | U27 | CPU | A-5343-564-2 |
| Game ROM 2 | 16K x 8 ROM | 27128 | U26 | CPU | A-5343-564-1 |
| Sound ROM 1 | 32K x 8 ROM | 27256 | U21 | CPU | A-5343-564-4 |
| Sound ROM 2 | 32K x 8 ROM | 27256 | U22 | CPU | A-5343-564-3 |
| Music/Speech ROM 1 | 32K x 8 ROM | 27256 | U4 | Audio | A-5343-564-5 |
| Music/Speech ROM 2 | 32K x 8 ROM | 27256 | U19 | Audio | A-5343-564-6 |

NOTICE

To order a replacement ROM from your authorized WILLIAMS ELECTRONICS GAMES distributor, specify: (1) part number (if available); (2) ROM label color; (3) ROM level (number) on the label; (4) which game the ROM is used in.

CONNECTOR IDENTIFICATION

WILLIAMS ELECTRONICS GAMES uses a special technique to identify connectors. Each plug or jack receives a prefix number (which identifies the circuit board), a letter, and a number. J-designations refer to the male part of a connector. P-designations refer to the female part of a connector. For example, 1J1 designates jack 1 of board 1 (a CPU Board jack); 3P6 designates plug 6 of board 3 (a Power Supply Board plug).

Identifying the specific pin number of a connector involves a hyphen, which separates the pin number from the plug or jack designation. For example, 1J1-3 refers to pin 3 of jack 1 on board 1.

CYCLONE CIRCUIT BOARDS

CYCLONE's System 11B Circuit Boards are in the backbox. They are accessible by removing the backbox glass, unlatching the insert board, and swinging it open.

CPU BOARD. The System 11B CPU Board (p/n D-11883-564) must be equipped with the ROMs specified in the CYCLONE (System 11B) ROM Summary. For this ROM complement and CPU Board, jumpers W1, W2, W4, W5, W7, W8, W11, W14, W16, W17, and W19 must be connected. (Jumper W7 is cut/removed for West German games.)

AUDIO BOARD. The Audio Board is p/n D-11581-564, as supplied with ROMs and micro-processor.

DISPLAY BOARD. The Alphanumeric Display Unit Board is p/n D-11609.

POWER SUPPLY BOARD. The Power Supply Board is p/n D-8345-557.

AUX POWER DRIVER BOARD. The Aux Power Driver Board is D-11813-564.

Prefix numbers for the System 11B circuit boards and other major assemblies are listed below. A prefix number may precede a component designator to identify the unit (e.g., connector 1J1).

| | | |
|--------------------------|---------------------|---------------------|
| 1 - CPU | 6 - Backbox | 11 - Audio |
| 2 - (not assigned) | 7 - Cabinet | 12 - (not assigned) |
| 3 - Backbox Power Supply | 8 - Playfield | 13 - (not assigned) |
| 4 - Alphanumeric Display | 9 - Insert Board | 14 - (not assigned) |
| 5 - Aux Power Driver | 10 - (not assigned) | 15 - (not assigned) |

CYCLONE GAME CONTROL LOCATIONS

The On-Off switch is on the bottom of the cabinet near the right front leg.

The Volume Control is on the left inner wall of the cabinet on the tilt mechanisms board. It is accessible by opening the coin box door.

The Credit switch is a pushbutton to the left of the coin door on the cabinet exterior.

GAME ADJUSTMENT/DIAGNOSTIC SWITCHES. CYCLONE allows the operator to program virtually all game adjustments, obtain bookkeeping information, and diagnose problems, using only three switches mounted on the inside of the coin door and the Credit button beside the coin door.

ADVANCE, AUTO-UP/MANUAL-DOWN, and HIGH-SCORE RESET are the switches located on the inside of the coin door. Refer to the Game Status Displays text and the Text/Diagnostic Procedures for details concerning their operation.

The Memory Protect switch is on the inside frame of the coin door. This interlock switch must be open to clear bookkeeping totals and to make game adjustments. It automatically opens, when the coin door opens.

CYCLONE GAME CONTROL LOCATIONS (Continued)

The CPU Diagnostic switch (SW 2) is the lower switch (of the two switches mounted on the left edge of the CPU Board) near a large, socketed microprocessor chip. This switch initiates the Memory Chip Test explained in the Test/Diagnostic Procedures.

The Sound Diagnostic switch (SW 1) is the upper switch of the two mounted on the left edge of the CPU Board. This switch initiates the Sound Section Test. Refer to the Test/Diagnostic Procedures.

PINBALL GAME ASSEMBLY INSTRUCTIONS

1. Open the shipping container; remove all cartons, parts, and other items, and set them aside.
2. Place cabinet on a support and attach rear legs (after installing leg levellers), using leg bolts. Leg levellers and leg bolts are both provided among the parts in the cash box.
3. Attach the front legs (after installing leg levellers), using leg bolts. See Figure 1 for details.

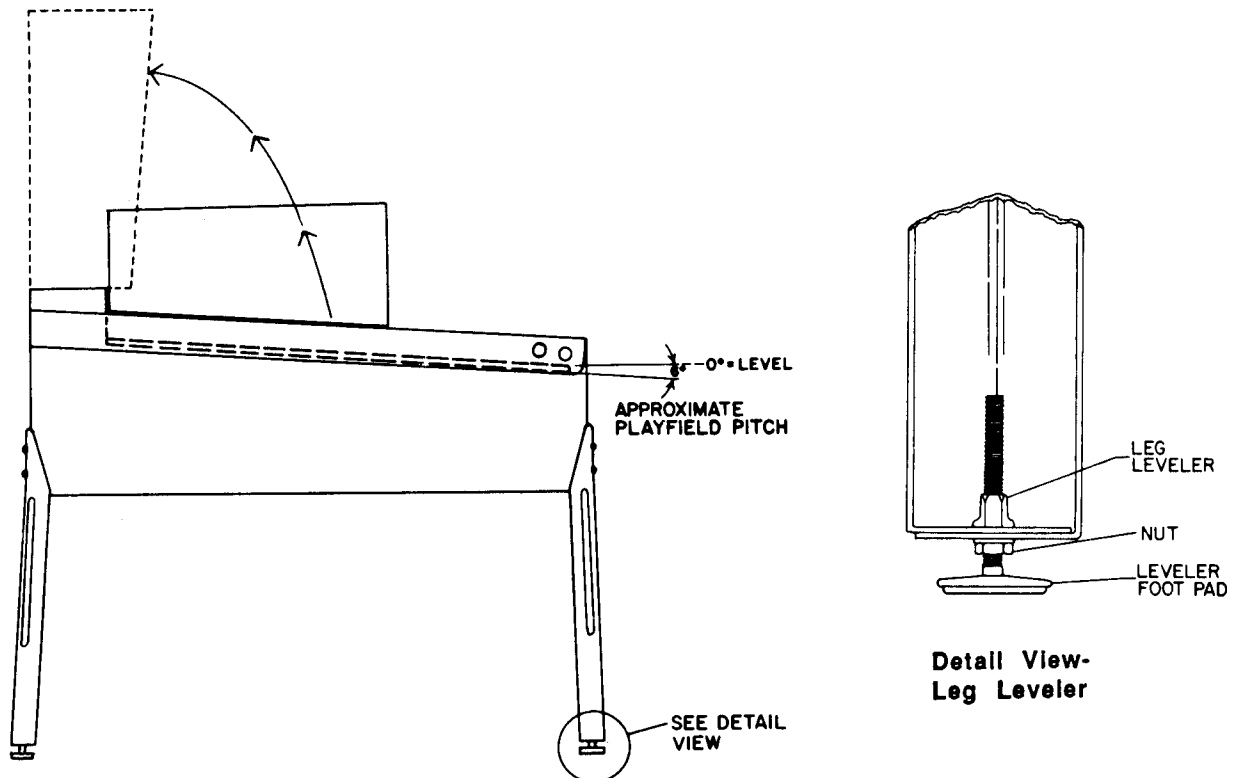

Figure 1. Pinball Assembly, Playfield Pitch Angle, and Leg Leveler Details.

4. Reach into the cabinet and backbox and check the mating of the interconnecting cables, matching several wire colors at each connector. Ensure that all connections are properly secure.

CAUTION

Ensure that the interconnecting cables are free to move (not kinked or pinched). Be careful not to damage wires at any stage of the assembly process.

5. Raise the hinged backbox upright and stabilize it into position, using the clamp on the back of the cabinet and backbox. Unlock the backbox, and remove the backbox glass, storing it carefully to avoid scratches. Remove the shipping block holding the Insert Board. Unlatch the Insert Board and open it, then lift the Speaker/Display Panel up and lay it forward on the playfield cabinet. This allows access to the bolt holes used for securing the backbox upright. Install the mounting bolts and flat washers through the bottom holes of the backbox into the threaded fasteners in the cabinet to secure the backbox.

PINBALL GAME ASSEMBLY INSTRUCTIONS (Continued)

WARNING

NEVER transport a pinball game with the hinged backbox erect. *Always* lower the backbox forward onto the playfield cabinet on a layer of protective material to prevent marring or damage and possible personal injury.

6. Extend each leg leveler *slightly* below the leg bottom, so that all four foot pads are extended about the same distance. Remove the cabinet from its support and place it on the floor.
7. Adjust the leg levelers for proper playfield level (side-to-side) and playfield pitch angle (incline) of approximately 6 degrees. (Again, it is recommended that these measurements be made **ON** the playfield, not the cabinet nor the playfield cover glass.) Tighten the nut on each leg leveler shaft to maintain this setting, as shown in Figure 1.

CAUTION

Playfield pitch angle adjustments can affect the operation of the plumb bob tilt, inside the cabinet. The operator should adjust this tilt mechanism for proper operation, after completion of the desired playfield pitch angle setting.

8. Move the game into the desired location; recheck the level and pitch angle of the playfield.
9. Verify that the **required number** of balls are installed in the game. (*CYCLONE*: 1 ball.)
10. Clean and re-install the playfield cover glass. Prepare the game for player operation.

GAME OPERATION

WARNING

After assembly and installation at its site location, this game must be plugged into a properly grounded outlet to prevent shock hazard, and to assure proper game operation. **DO NOT** use a 'cheater' plug to defeat the ground pin on the line cord. **DO NOT** cut off the ground pin.

POWERING UP. With the coin door closed, plug the game in, and switch it ON, using the On-Off switch. In normal operation, the player 1 score display initially shows 00. Then, the game goes into the Attract Mode (playfield and backbox lamps flashing, sounds being heard, etc., if the operator does not change the Factory Setting).

Open the coindoor and press the AUTO-UP/MANUAL-DOWN switch to MANUAL-DOWN. Press the ADVANCE button to begin the game test routine. Return to AUTO-UP and perform the entire test to verify that the game is operating satisfactorily.

NOTE

CYCLONE's SYSTEM 11B game program has a great capability to aid the operator and service personnel: At game Turn-On (and also at the beginning of the Test/Diagnostic Procedures), the Player 1 display now signals, with a decimal point by the rightmost character, that at least one switch has NOT been actuated during ball play for 120 balls (\approx 40 games). [Note: Only one dot appears; although more than one switch may be affected.] Moreover, *CYCLONE* compensates the game play requirements affected by each disabled switch to allow 'nearly normal' play. This helps keep *CYCLONE* earning good profits! More information is available in the Test/Diagnostic Procedures text describing the Switch Testing.

ATTRACT MODE*. Playfield and backbox lamps blink. All player score displays exhibit a series of messages informing the player concerning:

- A. Recent highest scores*;
- B. A "custom message"
("TAKE A CHANCE ... AND RIDE... THE CYCLONE")*;
- C. The score to achieve to obtain a Replay award*;

GAME OPERATION (Continued)

These (or similar) displays reappear occasionally, accompanied by sounds and music, until a player initiates game play by inserting a coin or, when credits are available, pressing the Credit button.

CREDIT POSTING. Insert coin(s). A sound is heard for each coin, and the player score displays show the number of credits purchased. So long as the number of maximum allowable credits* are *NOT* exceeded by coin purchase or high score, credits are posted correctly. However, after this maximum credits value is reached, posting of additional credits won (not purchased) by the player does *not* occur. *ONLY* posting of *purchased* credits occurs beyond the maximum credits value.

STARTING A GAME. Press the Credit button once. A startup sound plays, and the Credit amount shown in the player score display decreases by one. Player display 1 flashes 00 (until the first playfield switch is actuated), and the Player 4 display shows **ball 1**, except for 4-player games where the **ball #** shows in the individual player's display. Additional players may enter the game by pressing the Credit button once for each player, before the end of play on the first ball.

TILT. Actuating the Slam Tilt switch on the coin door inside the cabinet ends the current game; *CYCLONE* then proceeds to the Game Over Mode. With the actuation of the playfield tilt switch, or the third closure* of the plumb bob tilt switch, the player loses the remaining play of that ball, but can complete the game.

END OF GAME. All earned scores and bonuses are awarded. If a player's final score exceeds the specified value, the player receives a designated award for achieving the current highest score. A random digit set* appears in the Match display. Credit* may be awarded, when the last two digits of any player's score display (1 through 4) match the random digits of the Match display. Match, high score, and game over sounds are made, as appropriate.

GAME OVER MODE. The GAME OVER display shows in the player score displays. Then, the high scores flash on the appropriate player score displays. The game proceeds to the Attract Mode.

* - operator-adjustable feature

CYCLONE GAME STATUS DISPLAYS

CYCLONE provides the game owner/operator with a display of information concerning the game's bookkeeping and game play feature adjustments. Basically, three classes of information now become available in this status display mode: Id (Identification); Au (Audit); Ad (Adjustment). Each of the underscored two-letter abbreviations for these classes appears in the Player 3 score display, while the system microprocessor for the *CYCLONE* game is displaying the items within each class.

Identification Information--Id

With the game turned on, the coin door open, and the AUTO-UP/MANUAL-DOWN switch in the AUTO-UP position, the operator can press the ADVANCE switch once, briefly. *CYCLONE*'s displays immediately change from the Attract Mode to the Game Status Display Mode. This is evident by the following display, shown in columnar form. The column headings refer to the various backbox displays.

| Player 1 | Player 2 | Player 3 | Player 4 |
|----------------|--------------|-------------|-------------|
| CYCLONE | Id 00 | 564 | L-x* |

* x - indicates ROM revision level; e.g., 1 is initial issue; 2, 3, etc. for later revisions.

The game is named in the Player 1 score display. The game's identification number shows in the Player 2 score display and the ROM revision level appears in the Player 4 display. The Player 3 score display shows the status display mode in abbreviated form, *Id*. The Player 3 score display also shows the status display mode item (**00**) for this particular display.

Pressing ADVANCE once more causes the **Id 01** display to appear. This display describes which of the "Install" options is currently in effect. For example, if the YES option of the INSTALL FACTORY Adjustment Item (Ad 70) was last selected, *FACTORY SETTING* appears on the player score displays. Changing the setting of any other game adjustment item, after selecting the YES option for Ad 70 causes the display to change to *FACTORY ALTERED*. Similarly, if the operator selects the YES option for INSTALL HARD (Ad 65), the display indicates *HARD SETTING*. Changing a game adjustment item later then causes the display to show *HARD ALTERED*.

Audit Information--Au

While the AUTO-UP switch remains in the Up position, the operator can press the ADVANCE switch once, briefly, to begin the backbox displays of Audit (sometimes called "bookkeeping") Information. Forty-four audit entries are now available. Calculation of the various factors is no longer necessary because the System 11B game program now performs all the mathematical factor computations. This information is intended to aid the owner/operator in evaluating how the game is performing in each location, by providing knowledge about which game features are receiving the most play. With this information, the owner/operator can determine whether adjusting the game features to other settings will contribute to increased game earnings.

The operator can press the ADVANCE button once to view each Audit Information display item. To proceed more rapidly through this information, the operator only has to press and hold the ADVANCE button. If a desired item is passed, the operator can use the MANUAL-DOWN switch position with the ADVANCE button to back up to the desired item.

The **CYCLONE Audit Table** lists the 49 items of the Audit Information portion of the *CYCLONE* Game Status Displays. Presentation of this Audit Information again utilizes the player score displays; however, the Player 1 and 2 displays are combined as a descriptive phrase. The light type below the table's column headings names the respective backbox displays where the information appears. Because the Player 4 display contains information which depends on game play, only a few example entries are shown in the table. The Credits display shows *Au* for all 49 audit items, so its entry is omitted from the tabular listing. Detection of erroneous data affecting any of the counters used in these audit items causes the message, **ERROR**, to be displayed in the Player 3 display, during display of any audit item associated with that particular counter. (The program does not analyze the cause of the error; it merely alerts the operator of the error's existence by the message.)

CYCLONE GAME STATUS DISPLAYS (Continued)

CYCLONE Audit Table

| Audit Item (Player 3) | Descriptive Phrases (Player 1 and 2 Displays) | Audit Factor ¹ Value (Player 4) |
|--|--|--|
| AU 01 | LEFT COINS [chute next to coin door hinge] | 432 |
| 02 | CENTER COINS | 0 |
| 03 | RIGHT COINS | 398 |
| 04 | PAID CREDITS | 830 |
| 05 | TOTAL PLAYS | |
| 06 | TOTAL FREE (Total Free Plays) | |
| 07 | PERCENT FREE (% Free Plays) | |
| 08 | REPLAY AWARDS | |
| 09 | PERCENT REPLAY (% Replay Awards) | |
| 10 | SPECIAL AWARDS | |
| 11 | PERCENT SPECIAL (% Special Awards) | |
| 12 | MATCH AWARDS | |
| 13 | HSTD (High Score to Date) CREDITS | |
| 14 | PERCENT HSTD (% HSTD Credits) | |
| 15 | EXTRA BALLS | |
| 16 | PERCENT EX. BALL (% Extra Balls) | |
| 17 | AV. BALL TIME (Average Time in Seconds) | |
| 18 | MIN. OF PLAY (Minutes of Play) | |
| 19 | BALLS PLAYED | |
| 20 | REPLAY1 AWARDS | |
| 21 | REPLAY2 AWARDS | |
| 22 | REPLAY3 AWARDS | |
| 23 | REPLAY4 AWARDS | |
| 24 | 1 PLAYR. GAMES | |
| 25 | 2 PLAYR. GAMES | |
| 26 | 3 PLAYR. GAMES | |
| 27 | 4 PLAYR. GAMES | |
| 28 | BURN IN CYCLES | |
| 29 | JACKPOT AWARDS (# of times Gate Bonus Jackpot awarded) | |
| 30 | 1 MILL. AWARDS (# of times 1 Million shot achieved) | |
| 31 | FERRIS AWARDS (# of times Ferris Wheel Bonus awarded) | |
| 32 | SHUTTLE 100K'S (# of times 100K plunger shot achieved) | |
| 33 | M. WHEEL SPINS (# of times Mystery Wheel spun) | |
| 34 | CYCLONE SHOTS (# of times Cyclone lit value awarded) | |
| 35 | COMET SHOTS (# of times Comet lit value awarded) | |
| 36 | OUTLANE EX. BALL (# of Ex. Balls via Outlane) | |
| 37 | X SPECIAL (# of Specials via Bonus Mult.) | |
| 38 | L/R DRAINS (# of times ball drained via L/R outlane) | |
| 39 | H.S.RESET COUNTER | |
| 40 | 0.0-0.4 M. SCORE (# of games <500K) | |
| 41 | 0.5-0.9 M. SCORE (# of games ≥500K, <1M) | |
| 42 | 1.0-1.4 M. SCORE (# of games ≥1M, <1.5M) | |
| 43 | 1.5-1.9 M. SCORE (# of games ≥1.5M, <2.0M) | |
| 44 | 2.0-2.4 M. SCORE (# of games ≥2.0M, <2.5M) | |
| 45 | 2.5-9.9 M. SCORE (# of games ≥2.5M or more) | |
| 46 | H.S.T.D. 1> ??? (1st in HSTD Table, w/Initials) | |
| 47 | H.S.T.D. 2> ??? (2nd in HSTD Table, w/Initials) | |
| 48 | H.S.T.D. 3> ??? (3rd in HSTD Table, w/Initials) | |
| 49 | H.S.T.D. 4> ??? (4th in HSTD Table, w/Initials) | |
| <p>NOTE:</p> <p>1. The numbers shown in this column for Items 1 through 4 are examples. Entries for all items depend on the amount of play; thus, they will vary from location to location.</p> | | |

Adjustment Information--Ad

At end of the Audit Information presentation, with the AUTO-UP switch in the Up position, the operator can press the ADVANCE button to proceed to the Adjustment Information portion of the CYCLONE Game Status Displays, as listed in the **CYCLONE Game Adjustment Table**.

CYCLONE GAME STATUS DISPLAYS (Continued)

The operator can press the ADVANCE button once to view each Adjustment Information display item. To proceed more rapidly through this information, the operator only has to press and hold the ADVANCE button. If a desired item is passed, the operator can use the MANUAL-DOWN switch position with the ADVANCE button to back up to the desired item.

CYCLONE Game Adjustment Table

| Adjustment Item (Player 3) | Descriptive Phrases (Player 1 and 2 Displays) | Factory Setting (Player 4) |
|----------------------------------|---|---|
| Ad 01 | AUTO REPLAY ¹ or FIXED REPLAY ¹ | 10 (%) SCORES ¹ |
| 02 | REPLAY START (or REPLAY LEVEL 1) ¹ | 2,000,000 |
| 03 | REPLAY LEVELS (or REPLAY LEVEL 2) ¹ | 01 (or OFF) |
| 04 | (REPLAY LEVEL 3) ¹ | (see text) |
| 05 | (REPLAY LEVEL 4) ¹ | (see text) |
| 06 | REPLAY AWARD | Credit |
| 07 | SPECIAL AWARD | Credit |
| 08 | MATCH FEATURE | [Off, 1 - 50%] 10 (%) |
| 09 | BALLS / GAME | 03 |
| 10 | TILT WARNING | 03 |
| 11 | EX. BALL / B. I. P. | { [00 = NO Ex. Ball; 1-9 E. B. /Ball; 1-9 E. B. /B. I. P.; 1-9 E. B. /Game] } |
| 12 | MAXIMUM CREDITS | 10 |
| 13 | HIGHEST SCORES | [On; off; auto=prgmd change] On |
| 14 | BACKUP HI. SCR.1 | 3,200,000 |
| 15 | BACKUP HI. SCR. 2 | 3,000,000 |
| 16 | BACKUP HI. SCR. 3 | 2,800,000 |
| 17 | BACKUP HI. SCR. 4 | 2,500,000 |
| 18 | HI. SCR.1 CREDITS | 01 |
| 19 | HI. SCR.2 CREDITS | 01 |
| 20 | HI. SCR.3 CREDITS | 01 |
| 21 | HI. SCR.4 CREDITS | 01 |
| 22 | H. S. RESET EVERY (3,000 PLAYS) ² | |
| 23 | FREE PLAY | NO |
| 24 | U.S.A. 1 COINAGE (1 COIN 1 PLAY) ^{2,3} | |
| 25 | LEFT UNITS | 01 |
| 26 | CENTER UNITS | 04 |
| 27 | RIGHT UNITS | 01 |
| 28 | UNITS/ CREDIT | 01 |
| 29 | UNITS/ BONUS | 00 |
| 30 | MINIMUM UNITS | 00 |
| 31 | COMET TIMER | [Untimed; 1-99 sec for lit COMET shot] 20 sec |
| 32 | DOUBLE SCORE T. | [Untimed; 1-99 sec duration for Dbl Scores] 20 sec |
| 33 | SPOOK H. TIMER | [Untimed; 1-99 sec for Spookhouse] 15 sec |
| 34 | ADVANCE X TIMER | [Untimed; 1-99 sec for ADV. X shot] Off |
| 35 | CYCLONE TIMER | [Untimed; 1-99 sec for lit CYCLONE shot] 15 sec |
| 36 | FERRIS W. TIMER | [Untimed; 1-99 sec for Ferris Wheel shot] 15 sec |
| 37 | MILLION TIMER | [Untimed; 1-90 sec for Million shot] 10 sec |
| 38 | CYCLONE MEMORY | [ball st. lit=lit at start of each ball; mem lit= lit at game start & stored; mem unlit=off at game start & stored; no mem lit=lit at game start/not stored;no mem unlit=off & not stored] Mem Lit |
| 39 | COMET MEMORY | [ball st. lit=lit at start of each ball;mem lit=lit at game start & stored; mem unlit=off at game start & stored; no mem lit=lit at game start/not stored;no mem unlit=off & not stored] Mem Lit |
| 40 | MILLION IN _ SHOTS | [3 - 6;# of Comet ramp shots for 1M score] 5 Shots |
| 41 | FERRIS BON. ADV. | [100-9900; J. Bumper score increase for Ferris Wheel Bonus] 3,000 |

CYCLONE GAME STATUS DISPLAYS (Continued)

The **CYCLONE Game Adjustment Table** lists the 70 items of the Adjustment Information portion of the **CYCLONE** Game Status Displays. Presentation of the displays is similar to that for the Audit Information (that is, the player 1 and 2 displays combine as a descriptive phrase; the light type below the column headings names the respective backbox displays where the information appears, etc.). The Player 3 display shows *Ad* for all 70 adjustment items, so its entry is omitted from the tabular listing.

CYCLONE Game Adjustment Table (Continued)

| Adjustment Item (Player 3) | Descriptive Phrases (Player 1 and 2 Displays) | Factory Setting (Player 4) |
|-------------------------------|---|-------------------------------|
| 42 | GATE BON. ADV. [1K-99K; Gate Bon. increase via 1-2-3 lanes] | 5,000 |
| 43 | EX. BALL AUTO AD. [Off; 1-99 % for all Ex. Balls] | 33% |
| 44 | DUCKS EX. BALL [3-5; # of compl of 3 Duck Tgt for Ex Ball] | 3 Sets |
| 45 | SPECIAL AUTO AD. [Off; 1-90 % for all Specials] | 5% |
| 46 | SPECIAL _X [Off; 1X-7X=flashing #X for Special] | 5X |
| 47 | CONSOL. TIME [Off, 1-99 sec; min. game time] | 67 sec |
| 48 | A. MODE SOUNDS [ALOT; LESS; NONE] | ALOT |
| 49 | CUSTOM MESSAGE ⁴ | ON |
| 50 | SW. ALARM KNOCKER [yes=knock for inop switch; no=no knock] | NO |
| 51 | ENGLISH TEXT | |
| 52 | BON. MULT MEMORY [Yes-No; yes=2x-7x lamps stored for next ball play; no=not stored] | YES |
| 53 ⁵ | INSTALL GERMAN 1 ⁶ | |
| 54 ⁵ | INSTALL GERMAN 2 ⁶ | |
| 55 ⁵ | INSTALL GERMAN 3 ⁶ | |
| 56 ⁵ | INSTALL GERMAN 4 ⁶ | |
| 57 ⁵ | INSTALL GERMAN 5 ⁶ | |
| 58 ⁵ | INSTALL GERMAN 6 ⁶ | |
| 59 ⁵ | INSTALL ADDABALL | NO |
| 60 ⁵ | INSTALL 5-BALL | NO |
| 61 ⁵ | INSTALL NOVELTY | NO |
| 62 ⁵ | INSTALL EX. EASY | NO |
| 63 ⁵ | INSTALL EASY | NO |
| 64 ⁵ | INSTALL MEDIUM | NO |
| 65 ⁵ | INSTALL HARD | NO |
| 66 ⁵ | INSTALL EX. HARD | NO |
| 67 | AUTO BURN-IN | NO |
| 68 | CLEAR COINS | NO |
| 69 | CLEAR AUDITS | NO |
| 70 | INSTALL FACTORY | NO |

NOTES:

1. Automatic Replay percentage value range is adjustable from 5 to 25%, via the Credit button. Item 02 permits changing the factory setting value for Replay Start Level (valid for next 50 games played). Item 03 permits setting up to four replay levels, with values as detailed in text describing item 03. For Fixed Replay Scores set Auto Replay value to 1 less than 5(%) via the Credit button. Go to items 02, 03, 04, and 05; install their replay level scores. Turn off any replay level by setting 00 as its value.
2. Phrase in parentheses is Factory Setting. Phrase appears in player 3 and 4 displays. Press Credit button to change setting of item 22, or the game pricing of item 24.
3. To change country OR coinage setting, press Credit button to obtain 16 Standard settings, followed by a Custom Setting. The Custom Setting activates items 25 through 30. When a Standard Setting is used, items 25 through 30 are set automatically, and cannot be changed.
4. To install Custom Message, press flipper button for alphabet and special characters. Press Credit button for next message letter or character.
5. Special Preset Adjustment, whose effects are noted in the Game Adjustment text.
6. Refer to Pricing Table and text describing these items.
7. Approximates Ad 64, yet includes all factors listed in Factory Setting column, not just Ad 31 through 46 and 52 provided by Ad 64.

GAME ADJUSTMENT PROCEDURE

Adjustment Items 01 through 70

The coin door must be open to access the Game Adjustment/Diagnostic switches. All readings and setting changes require operation of these coin door switches. Some setting changes utilize the Credit button; some also use the flipper button(s). *Additional text describing the game adjustment items follows this procedure; the value of the Factory Setting for each Game Adjustment item is in the preceding **CYCLONE Game Adjustment Table**.*

1. Use AUTO-UP and press ADVANCE. The Id 00 display initially appears. Press ADVANCE until the Player 3 display indicates **Ad 01**. If the factory setting has not changed, the Player 1 and 2 Score displays indicate AUTO REPLAY, and the Player 4 display shows 10%, indicating a 10% replay percentage. (The game program adjusts itself automatically, as discussed in the following text concerning the 'details' about Adjustment Item 01.)
2. To reach a higher item number (in the Player 3 display), use AUTO-UP and press ADVANCE. To return to a previous item number, use MANUAL-DOWN and press ADVANCE.
3. With the desired Game Adjustment Item number showing in the Player 3 display, increase the setting value (or select another option) shown in the Player 4 display by using AUTO-UP and pressing the Credit button. Repeat this step for each item, until all changes to the factory settings for the Game Adjustment Items have been made. The preceding Game Adjustment Table consolidates the Factory Settings into one grouping.

(The same procedure can be used for Audit Items. To zero **Au 01 - 04** (concerning the coin chutes and the total coins), the operator can proceed to item 68, Clear Coins, and press the Credit button to obtain the YES option. The operator then presses the ADVANCE button and notes the "COINS CLEARED" display, which verifies that the entry values for items 01 through 04 of the Audit Items are now reset to zero.)

For example, the operator may desire to change the degree of game play difficulty from the Factory Setting (equivalent to the Install Medium [Ad 64] difficulty, along with a number of other automatically installed settings, as shown in the right column of the Game Adjustment Table) to another difficulty more suitable for the players at a particular game site. Four other 'automatic' play difficulty settings (Ad 62 - Ad 66) are available, each of which, if selected, installs all the adjustments listed for that difficulty in the Game Adjustment Setting Comparison Table, which follows the 'details' text.

4. To proceed rapidly through the entire adjustments series, press *and hold* ADVANCE, until **Ad 70** shows in the Player 3 display. From item 70, you can: (A) return to the Game-Over Mode; or (B) restore factory settings and zero audit (bookkeeping) totals. Perform either of the following, as desired:
 - A. To reach Game-Over Mode, use AUTO-UP and press ADVANCE once. **CYCLONE** now goes to the Game-Over Mode.
 - B. To restore the Factory Settings for Game Adjustment Items (as listed in the Game Adjustments Table), zero all audit (bookkeeping) totals, *and* return to Game-Over Mode, use AUTO-UP or MANUAL-DOWN to display Ad 70 in the Player 3 display. Press the Credit button to display the YES option in the Player 4 display. Using AUTO-UP, press ADVANCE once. **CYCLONE** now zeroes ALL Audit Item totals and changes ALL Game Adjustment Items back to those originally selected as Factory Settings. It then shows the operator a message ("FACTORY SETTING") that this has occurred. (A problem in the Memory Protection circuit or closing the coin door will cause the message "ADJUST FAILURE" to appear.) Press ADVANCE once more to return to the Game-Over Mode.

GAME ADJUSTMENT PROCEDURE (Continued)

Details of Adjustment Items 01 through 70

01 Auto Replay (or Fixed Replay)

Of the two options, AUTO REPLAY is the percentage of replays automatically awarded per game. The game program aids a pinball's initial installation by causing a comparison of the value of the Replay Level to the value of all players' scores every 50 games for the first 1,000 games. At each comparison, the program increases (or decreases) the Replay Level by an amount necessary to achieve the replay percentage specified either via the factory setting (or later operator selection). (After the first 1,000 games, the comparison occurs after every 500 games. The adjustment value is 100K, for this (and each subsequent) comparison.) Use the Credit button to change the percentage within the range of 5 to 25 (%), with the value increasing using AUTO-UP (or decreasing using MANUAL-DOWN). The next Credit button change below 5%, selects the FIXED REPLAY option.

For AUTO REPLAY, Ad 02 provides the Starting Replay Level (Player 1 and 2 displays show REPLAY START). Ad 03 provides the number of replay levels (01, 02, 03, or 04). *CYCLONE* then proceeds to Ad 06 automatically.

For FIXED REPLAY, Ad 02 is the first replay level (REPLAY LEVEL 1). Ad 03, 04, and 05 are the other replay levels.

02 Starting Replay Level (or Replay Level 1)

For AUTO REPLAY (refer to Ad 01), the initial Factory Setting is listed in the Game Adjustment Table, but this will change when the game compares the players' scores with this adjustment's value during its auto adjustment activity. The range of settings is 800,000 through 4,000,000 (by increments of 100,000 with AUTO-UP or decrements of 100,000 with MANUAL-DOWN).

For FIXED REPLAY, the operator can enter the value to be used for the first fixed replay score level via the Credit button. The range of settings is: OFF; 100,000 through 9,900,000 (by increments of 100,000 with AUTO-UP, or decrements of 100,000 with MANUAL-DOWN).

03 Replay Levels (or Replay Level 2)

For AUTO REPLAY (refer to Ad 01), this is the number of replay levels in a game. The option range is *one, two, three, or four* replay level(s). When the operator chooses two replay levels, *CYCLONE* automatically adjusts the second replay level to be twice the value selected for Ad 02, the starting replay level. Choosing three or four replay levels automatically adjusts their replay levels to three times or four times the Ad 02 value.

For FIXED REPLAY, the technique of value entry and the range of settings are identical to those of Ad 02.

04 (Replay Level 3)

For AUTO REPLAY, this Adjustment Item is not applicable. *CYCLONE* automatically bypasses this adjustment.

For FIXED REPLAY, the technique of value entry and the range of settings are identical to those of Ad 02.

05 (Replay Level 4)

For AUTO REPLAY, this Adjustment Item is not applicable. *CYCLONE* automatically bypasses this adjustment.

For FIXED REPLAY, the technique of value entry and the range of settings are identical to those of Ad 02.

GAME ADJUSTMENT PROCEDURE (Continued)

06 Replay Award

For either AUTO REPLAY or FIXED REPLAY (Ad 01), the operator can select the form of the award automatically provided when the player exceeds any Replay Level (Automatic or Fixed). The choices are:

- Credit* - Reaching each replay level obtains a credit (free game).
- Ball* - Reaching each replay level obtains an extra ball.
- Audit* - Reaching each replay level obtains nothing to the player; it does increase the entry value of the Audit Item(s) maintaining a tally of these awards (Au 08, and Au 20 through 23, as applicable).
- Coil* - Reaching each replay level causes the Kicker coil to activate once per free game won (instead of awarding a credit for each level exceeded). **NOTE:** A ticket dispenser or token dispenser, if installed, can be activated by the Kicker coil driver to provide an alternative award for each free game achieved by the player.

07 Special Award

The operator can select the form of the award automatically provided when the player scores a Special. The choices are:

- Credit* - Scoring each Special, when lit, obtains a credit (free game). A variation to this award occurs, when the setting of Ad 06 is Coil. (This permits a ticket or token dispenser to provide the award, when applicable.)
- Ball* - Scoring each Special, when lit, obtains an extra ball.
- Score* - Scoring each Special, when lit, obtains a score advance of 100,000 points to the player.

08 Match Award

The operator can select (via the Credit button) the desired percentage for the Match action occurring at the completion of each game. The choices are:

- 1%-50%* - 1% is 'hard'; 50% is 'extremely easy'. During Match action, the game selects a random two-digit number at end of game and compares each player's score for an identical two digits in the rightmost two positions. A matching of the two digits results in the award of a credit (or a ticket/token, if a dispenser is attached, and the setting of Ad 06 is Coil).
- Off* - The MATCH display does not operate at completion of the game; no award is given.

09 Balls / Game

The operator can define a "game" by specifying the number of balls to be played. The range of this setting is 1 through 9.

10 Tilt Warning

The operator can specify the number of total actuations of the plumb bob and playfield tilt mechanisms that can occur before the game is "tilted". The range of this setting is 1 through 5.

11 Extra Ball/Ball In Play

The operator can choose (via the Credit button) the number of Extra Balls to be awarded to a player. The range of this setting is:

GAME ADJUSTMENT PROCEDURE (Continued)

11 Extra Ball/Ball In Play (Continued)

- 00* - NO extra ball play; displays a message, NO EX. BALL. A score is awarded in lieu of the Extra Ball.
- 1-9 E. B./Ball* - 1 through 9 Extra Balls per ball (i.e., all balls including Extra Balls) are awarded.
- 1-9 E. B./B.I. P.* - 1 through 9 Extra Balls per Ball In Play (B. I. P.) (i.e., all balls NOT including Extra Balls) are awarded.
- 1-9 E. B./Game* - 1 through 9 Extra Balls per game.

12 Maximum Credits

The operator can specify the maximum number of credits the game can accumulate, either through game play awards or coin purchases. The range of settings is 5 through 99. Reaching the specified setting prevents the award of additional credits by game play. Coin purchases do continue to accumulate and are displayed.

NOTE

Whenever the number of credits is less than the specified maximum credits, any credits obtained by coin purchase or game awards (High Score, Match, Replay Levels, etc.) will be accumulated even though they exceed the maximum value. Thereafter, no additional credits can be accumulated, until the credit total is reduced below the specified maximum setting.

13 Highest Scores

The operator can specify (via the Credit button) whether the game is to maintain a record of the four highest scores achieved to date. The choices are:

- Off* - NO high scores are recorded.
- On* - The four highest scores are stored in memory for use by Game Adjustment 22.
- Auto* - The four highest scores are stored in memory for use in a game program subroutine associated with Game Adjustment 22.

14 Backup High Score 1

The operator can set the Backup High Score value in the Player 1 Score display, using the Credit button. The game automatically restores this value, when the operator presses, and holds, the HIGH SCORE RESET switch, or when an automatic High Score Reset event (Ad 22) occurs.

15 Backup High Score 2

This adjustment is similar to Ad 14, except that this applies to the Player 2 Score display. The adjustment technique is identical to Ad 14. It is also restored as described for Ad 14.

16 Backup High Score 3

This adjustment is similar to Ad 14, except that this applies to the Player 3 Score display. The adjustment technique is identical to Ad 14. It is also restored as described for Ad 14.

17 Backup High Score 4

This adjustment is similar to Ad 14, except that this applies to the Player 4 Score display. The adjustment technique is identical to Ad 14. It is also restored as described for Ad 14.

GAME ADJUSTMENT PROCEDURE (Continued)

18 Credits for Highest Score 1

The operator can select the number of credits to be awarded, by using the Credit button, whenever a player exceeds the previous Highest Score. The range of this setting is 00 through 10. A variation to this award occurs, when the setting of Ad 06 is Coil. (This permits a ticket or token dispenser to provide the award, when applicable.)

19 Credits for Highest Score 2

This adjustment is similar to Ad 18, except that this applies to the player's exceeding the second highest score. The Credit button adjustment technique is the same as for Ad 18. The range of this setting is 00 through 03.

20 Credits for Highest Score 3

This adjustment is similar to Ad 18, except that this applies to the player's exceeding the third highest score. The Credit button adjustment technique is the same as for Ad 18. The range of this setting is 00 through 03.

21 Credits for Highest Score 4

This adjustment is similar to Ad 18, except that this applies to the player's exceeding the fourth highest score. The Credit button adjustment technique is the same as for Ad 18. The range of this setting is 00 through 03.

22 Automatic High Score Reset

The operator can specify (via Credit button) that the game will provide an automatic reset of the displayed "Highest Scores", and the number of games to be played before the reset occurs. (Audit item 39 displays the games remaining before the reset.) The values provided upon reset are those selected by the operator in Ad 14 through 17, the Backup High Scores. The range of this setting is Off (to disable this adjustment), and 1,000 to 24,750 games (in increments of 250).

23 Free Play

The operator can select (via the Credit button) whether a player can operate the game without a coin (free play) or with a coin. The choices are:

- No - A coin is necessary for game play.
- Yes - Game play is free; no coin is required.

24 Coinage Selections

The operator can specify (via the Credit button) any of the 16 Standard Settings for game pricing, each of which exhibits a message identifying the country and the number of coins required and the number of games that the coin requirement purchases. Choosing a Standard Setting permits the game to omit items Ad 25 through 30, which are adjustments allowing for a special custom coinage setting.

Following the last Standard Setting is a Custom Coinage Setting, which allows the operator to utilize Ad 25 through 30 in establishing a special coinage setting. A message, CUSTOM COINAGE, indicates that the operator can enter the appropriate values into the Ad 25 through 30 adjustment items.

The values for Ad 25 through 30 of each Standard Setting, as well as other possible values for the Custom Coinage Setting are shown in the **Pricing Table**.

25 Left Chute Coin Units

The operator can specify (via the Credit button) the number of coin units purchased by a coin passing through the left coin chute.

GAME ADJUSTMENT PROCEDURE (Continued)

26 Center Chute Coin Units

The operator can specify (via the Credit button) the number of coin units purchased by a coin passing through the center coin chute.

27 Right Chute Coin Units

The operator can specify (via the Credit button) the number of coin units purchased by a coin passing through the right coin chute.

28 Units Required for Credit

The operator can define (via the Credit button) the number of coin units required to obtain 1 Credit. A coin unit counter in the game program totals the number of coin units purchased through all coin chutes prior to each game. If the total number of coin units purchased exceeds the 1 Credit factor by a multiple (or more, coin units) of the specified Units per Credit value, the Credits display shows the proper number of Credits. The coin unit counter retains any remaining coin units, until the start of a game; then, the coin unit counter is cleared (its contents are zeroed).

29 Units Required for Bonus

The operator can specify (via the Credit button) that 1 additional Credit is to be indicated in the Credits display, when a certain number of coin units are accumulated.

30 Minimum Units Required for any Credits Posted

The operator can specify that NO Credits are to be posted (indicated in the Credits display), until the credit units counter reaches a particular value.

31 COMET Timer

The operator can choose (via the Credit button) the time period for display of the COMET Score lamps (20K, 40K, ...100K). The range of this setting is *01 second* (Conservative) through *99 seconds* (Liberal), or *Off* (Extremely Liberal). Note that, when the time period elapses and either the 80K, 100K, or 'Lites 1 Million' lamp is blinking, all lamps go off. If either the 20K, 40K, or 60K lamp is blinking when the time elapses, the 40K lamp remains lit.

32 Double Scores Timer

The operator can choose (via the Credit button) the time period for the Double Scores feature, which begins upon completion of the 1 - 2 - 3 "Gate" Lanes. During Double Scores, all playfield scoring, except the Ferris Wheel Bonus, 'Gate Bonus', and Shuttle Bonus, is double the usual scoring. The range of this setting is *01 second* (Conservative) through *99 seconds* (Liberal), or *Off* (Extremely Liberal).

33 Spook House Timer

The operator can choose (via the Credit button) the time period for display of the Spook House lamp, which controls how often a player spins the Mystery Wheel for scores, Zilch, Extra Ball, or Special. (Extra Ball and Special awards are related to the settings of Adjustments 43 through 46. The range of this setting is *01 second* (Conservative) through *99 seconds* (Liberal), or *Off* (Extremely Liberal).

34 Advance X (Bonus Multiplier) Timer

The operator can choose (via the Credit button) the time period for display of each of the lighted Bonus Multipliers (2X - 7X). This adjustment mostly affects scoring, but it also affects the 'flashing Special' lamp. (Special awards are related to the settings of Adjustments 45 and 46. The range of this setting is *01 second* (Conservative) through *99 seconds* (Liberal), or *Off* (Extremely Liberal).

GAME ADJUSTMENT PROCEDURE (Continued)

35 CYCLONE Timer

The operator can choose (via the Credit button) the time period for display of each of the lighted Cyclone Score lamps (50K, 100K, 'Gate Bonus'). The range of this setting is *01 second* (Conservative) through *99 seconds* (Liberal), or *Off* (Extremely Liberal). Note that, when the time period elapses and the 'Gate Bonus' lamp is blinking, all lamps go off. If the 50K or 100K lamp is blinking when the time elapses, only the 50K lamp remains lit.

36 Ferris Wheel Timer

The operator can choose (via the Credit button) the time period for display of the lighted Ferris Wheel Bonus lamp. (The value of each player's Ferris Wheel Bonus increases with Jet Bumper play.) The range of this setting is *01 second* (Conservative) through *99 seconds* (Liberal), or *Off* (Extremely Liberal).

37 Million Timer

The operator can choose (via the Credit button) the time period for display of the lighted 1 Million lamp (on the Cyclone, but lighted by COMET play). The range of this setting is *01 second* (Conservative) through *99 seconds* (Liberal), or *Off* (Extremely Liberal).

38 CYCLONE Memory

The operator can choose (via the Credit button) whether the lighted Cyclone Score lamp (50K, 100K, 'Gate Bonus') is stored in memory for 'next ball' play (continues from ball to ball) or is reset at Game Start or at Ball Start. The choices are:

- Ball St. (start) Lit* - (Liberal) Lamp is turned on at ball start.
- Memory Lit* - Lamp is turned on at Game Start (stored in memory).
- Memory Unlit* - Lamp is turned off at Game Start (stored in memory).
- No Mem. Lit* - Lamp is turned on at Game Start (not stored in memory).
- No Mem. Unlit* - (Conservative) Lamp is turned off at Game Start (not stored in memory).

39 CYCLONE Memory

The operator can choose (via the Credit button) whether the lighted Comet Score lamp (20K... 100K, 1 Million) is stored in memory for 'next ball' play (continues from ball to ball) or is reset at Game Start or at Ball Start. The choices are:

- Ball St. (start) Lit* - (Liberal) Lamp is turned on at ball start.
- Memory Lit* - Lamp is turned on at Game Start (stored in memory).
- Memory Unlit* - Lamp is turned off at Game Start (stored in memory).
- No Mem. Lit* - Lamp is turned on at Game Start (not stored in memory).
- No Mem. Unlit* - (Conservative) Lamp is turned off at Game Start (not stored in memory).

40 Million in ___ Shots

The operator can choose (via the Credit button) how many consecutive shots up the Comet Ramp are necessary to obtain the 1 Million score *for the 1st time*. (After the first 1 Million shot, six consecutive Comet Ramp shots are necessary for each subsequent 1 Million award.) The range of this setting is 3 (Liberal) to 6 (Conservative). Note that the setting of this Adjustment can affect the Replay Level value, if too Liberal a setting is selected, allowing high scores.

41 Ferris Wheel Bonus Advancement

The operator can choose (via the Credit button) the point value for Jet Bumper play (directly increasing the value of each player's Ferris Wheel Bonus). The range of this setting is 100 (Conservative) to 9900 (Liberal), by increments of 100. **NOTE:** Each player affects only his individual Ferris Wheel Bonus, which starts at 50K and builds to a maximum of 500K.

GAME ADJUSTMENT PROCEDURE (Continued)

42 'Gate Bonus' Advancement

The operator can choose (via the Credit button) the point value for completing each set of 1-2-3 "Gate" Lanes. The 'Gate Bonus' starts at 500K and builds to a maximum of 4 Million (backglass lamps display the value). The range of this setting is 1,000 (Conservative) to 99,000 (Liberal), by increments of 1000. Note that the setting of this Adjustment can affect the Replay Level value (if too Liberal a setting is selected) allowing high scores.

43 Extra Ball Auto Adjustment

The operator can choose (via the Credit button) the percentage value for ALL Extra Balls. The range of this automatic adjustment setting is *Enabled 1%* (Hard) through *99%* (Extremely easy); it can also be turned off (disabled), via a setting of *Off*. When the automatic adjustment is turned on (enabled), the game program adjusts the setting, at the end of a game, after 50 games, except when the current value is within 2% of the setting. Then, no auto adjustment occurs.

44 Ducks Extra Ball

The operator can choose (via the Credit button) the degree of difficulty for lighting the Extra Ball lamp (left and right Return lanes) via the 3 Duck Targets; that is, how many times the player must hit all three Duck Targets. The range of this setting is *3 Sets of completions of all 3 Duck Targets* (Liberal) through *5 Sets of completions of all 3 Duck Targets* (Conservative). Note that, if Adjustment 43 (Extra Ball Auto Adjustment) is Enabled, it can change the setting within the range of 3 Sets to 5 Sets.

45 SPECIAL Auto Adjustment

The operator can choose (via the Credit button) the percentage value for all Specials per game. The range of this automatic adjustment setting is *Enabled 1%* (Hard) through *99%* (Extremely easy); it can also be turned off (disabled), via a setting of *Off*. When the automatic adjustment is turned on (enabled), the game program adjusts the setting, at the end of a game, after 50 games, except when the current value is within 2% of the setting. Then, no auto adjustment occurs.

46 SPECIAL ___X

The operator can choose (via the Credit button) the point at which the Bonus Multiplier turns on the Special lamp. The range of choices is 2X through 7X. Note that, if Adjustment 45 (Auto Adjustment) is Enabled, this Auto Adjustment has a range from 3X through 7X.

47 Consolation Time

The operator can choose (via the Credit button) the minimum game time below which a form of 'Consolation' becomes effective. This compensates for less skilled players to encourage them to continue playing the game. (Less skilled players are those whose game time is less than the selected setting, and who did not get a Special, an Extra Ball, or other type of 'specialty' shot. For these players, the game program lights the left Outlane Extra Ball lamp, to give them an additional chance to increase their score, but they must drain through that lane to obtain this assistance.) The range of this setting is *1 second* (Very Conservative) through *99 seconds* (Very Liberal), or *Off*.

48 Attract Mode Sounds

The operator can select (via the Credit button) the amount of sounds occurring during the Attract Mode. The choices are:

- ALOT* - Sounds occur for approximately 8 minutes during the Attract Mode sequence.
- LESS* - Sounds occur for approximately 2 minutes during only the Attract Mode.
- NONE* - No sounds occur during the Attract Mode.

GAME ADJUSTMENT PROCEDURE (Continued)

49 Custom Message

The operator can choose (via the Credit button) whether to display a message during the Attract Mode. (When display of a message is selected, the operator can either utilize the message provided or change the message.) Three choices are available:

- 1 - Display a message during the Attract Mode. The Player 4 display shows this choice as ON. The 3-line message provided is:
TAKE A CHANCE ... AND RIDE ... THE CYCLONE
- 2 - Do NOT display a message during the Attract Mode. (Player 4 shows OFF.)
- 3 - The Player 4 display shows this choice as CHANGE. The operator can enter a special ("custom") message, as follows:
 - A. Press ADVANCE once. The operator can now enter as many as three 14-character lines for display during the Attract Mode.
 - B. Use the flipper button(s) to select each message character (alphabet, numbers, and special symbols are available). In case of error, enter a "back arrow" (just before "space") to correct, followed by correct character. For a period after any letter, use letters with periods (following the special symbols). The entire character set is the following:
A B C D E F G H I J K L M N O P Q R S T U V W X Y Z 0 1 2 3 4 5 6 7 8 9 < > ? - / * '
A . B . C . D . E . F . G . H . I . J . K . L . M . N . O . P . Q . R . S . T . U . V . W . X . Y . Z . _
 - C. Move to the next character via the Credit button. No entirely blank lines will be displayed.

50 SW. ALARM KNOCKER

The operator can choose (via the Credit button) whether the knocker operates, sounding an alarm to signal a switch problem, at the time of game Turn-On and at the beginning of the Test/Diagnostic Procedures. Two choices are available:

- YES - The knocker sounds, signalling a switch problem, at game Turn-On and at the beginning of the Test/Diagnostic Procedures.
- NO - The knocker does NOT sound. (Player 4 shows NO.)

51 ENGLISH TEXT

The operator can choose to display the message, audit, adjustment, and Test /Diagnostic information in English or German (Deutsch) via the Credit button.

52 Bonus Multiplier Memory

The operator can choose (via the Credit button) whether the lighted Cyclone Bonus Multiplier Lamps (2X ... 7X) are stored in memory for 'next ball' play (continues from ball to ball) or are reset at Ball Start. The choices are:

- Yes - (Liberal) Lighted lamps are stored for 'next ball' play.
- No - Lighted lamps are not stored and are turned off at each Ball Start.

GAME ADJUSTMENT PROCEDURE (Continued)

SPECIAL PRESET ADJUSTMENTS CAUTION

Adjustments 53 through 66 are Special Preset Adjustments to enable the operator to perform the setting of multiple adjustments at once. They permit the operator to: (1) modify a game for a specific area (special German coinage settings, for example, Ad 53 through 58); (2) change a group of adjustments to conform with laws of certain localities (Ad 59 through 61); and (3) to change the degree of difficulty of game play (Ad 62 through 66). A list of the preceding individual Adjustments affected accompanies each of these Special Preset Adjustments. Whenever the operator chooses to use any Special Preset Adjustment, the operator can later access any or all of the individual Adjustments affected by that Special Adjustment for subsequent changes.

A similar technique is recommended in the event of error or uncertainty concerning any Special Preset Adjustment, after the operator selects it: The operator can restore the factory setting of each individual Adjustment, then select the desired Special Preset Adjustment, and then return to any of the preceding individual adjustments to determine whether use of the Special Adjustment has had the desired effect.

The Backbox displays for each Special Preset Adjustment indicate whether the operator has selected it, by identifying the Adjustment in the Player 1 and 2 displays by name and the selection choice of NO, meaning Not Selected (this is the Factory Setting), or YES, meaning Selected, in the Player 4 display. Operator installation of the 'selected' Preset Adjustment occurs by using the Credit button to choose YES and then pressing the ADVANCE switch. The displays then show the name of the Adjustment again, with DONE to show that the installation is now in effect.

Note that, when an operator installs any of the Special Preset Adjustments, Adjustment Items using the automatic adjust feature of the game program reset to the auto adjust value listed for that Adjustment Item.

NOTE

Games in which the CPU jumper W7 is cut ("German games") automatically have certain Adjustment Items preset:

| <u>Ad</u> | <u>Name</u> | <u>New Setting</u> | <u>Ad</u> | <u>Name</u> | <u>New Setting</u> |
|-----------|-----------------|--------------------|-----------|------------------|--------------------|
| 01 | Auto Replay | 15 (%) | 18 | Hi Scr 1 Credits | 03 |
| 02 | Replay Start | 2,500,000 | 19 | Hi Scr 2 Credits | 00 |
| 03 | Replay Level 2 | 03 | 20 | Hi Scr 3 Credits | 00 |
| 12 | Maximum Credits | 30 | 21 | Hi Scr 4 Credits | 00 |
| 14 | Backup Hi Scr 1 | 5,500,000 | 22 | Hi Scr Reset | 750 games |
| 15 | Backup Hi Scr 2 | 5,000,000 | 24 | German 2 Coinage | 7 Plays/5DM |
| 16 | Backup Hi Scr 3 | 4,500,000 | 47 | Consol. Time | 60 sec |
| 17 | Backup Hi Scr 4 | 4,000,000 | 51 | Deutsch Text | Deutsch |

53 Install German 1

The operator can modify the game pricing selection of Standard Setting 09 in the **Pricing Table** to permit Credit Award play with 10 games for 5 DM. Individual Adjustments are affected, as follows:

| <u>Ad</u> | <u>Name</u> | <u>New Setting</u> | <u>Ad</u> | <u>Name</u> | <u>New Setting</u> |
|-----------|-----------------|--------------------|-----------|------------------|--------------------|
| 06 | Replay Award | Credit | 17 | Backup Hi Scr 4 | 4,000,000 |
| 07 | Special Award | Credit | 18 | Hi Scr 1 Credits | 03 |
| 08 | Match Feature | 10 % | 19 | Hi Scr 2 Credits | 00 |
| 14 | Backup Hi Scr 1 | 5,500,000 | 20 | Hi Scr 3 Credits | 00 |
| 15 | Backup Hi Scr 2 | 5,000,000 | 21 | Hi Scr 4 Credits | 00 |
| 16 | Backup Hi Scr 3 | 4,500,000 | 24 | German 1 Coinage | 10 Plays/5DM |

54 Install German 2

The operator can modify the game pricing selection of Standard Setting 09 in the **Pricing Table** to permit Ticket/Token operation with 10 games for 5 DM. Individual Adjustments are affected, as follows:

GAME ADJUSTMENT PROCEDURE (Continued)

54 Install German 2 (Continued)

| <u>Ad</u> | <u>Name</u> | <u>New Setting</u> | <u>Ad</u> | <u>Name</u> | <u>New Setting</u> |
|-----------|-----------------|--------------------|-----------|------------------|--------------------|
| 06 | Replay Award | Coil | 17 | Backup Hi Scr 4 | 4,000,000 |
| 07 | Special Award | Ball | 18 | Hi Scr 1 Credits | 03 |
| 08 | Match Feature | 10 % | 19 | Hi Scr 2 Credits | 00 |
| 14 | Backup Hi Scr 1 | 5,500,000 | 20 | Hi Scr 3 Credits | 00 |
| 15 | Backup Hi Scr 2 | 5,000,000 | 21 | Hi Scr 4 Credits | 00 |
| 16 | Backup Hi Scr 3 | 4,500,000 | 24 | German 1 Coinage | 10 Plays/5DM |

55 Install German 3

The operator can modify the game pricing selection of Standard Setting 09 in the **Pricing Table** to permit Keyset Mode operation with 10 games for 5 DM. Individual Adjustments are affected, as follows:

| <u>Ad</u> | <u>Name</u> | <u>New Setting</u> | <u>Ad</u> | <u>Name</u> | <u>New Setting</u> |
|-----------|-----------------|--------------------|-----------|------------------|--------------------|
| 06 | Replay Award | Audit | 17 | Backup Hi Scr 4 | 00 |
| 07 | Special Award | Score | 18 | Hi Scr 1 Credits | 00 |
| 08 | Match Feature | Off | 19 | Hi Scr 2 Credits | 00 |
| 14 | Backup Hi Scr 1 | 00 | 20 | Hi Scr 3 Credits | 00 |
| 15 | Backup Hi Scr 2 | 00 | 21 | Hi Scr 4 Credits | 00 |
| 16 | Backup Hi Scr 3 | 00 | 24 | German 1 Coinage | 10 Plays/5DM |

56 Install German 4

The operator can modify the game pricing selection of Standard Setting 09 in the **Pricing Table** to permit Credit Award play with 7 games for 5 DM. Individual Adjustments are affected, as follows:

| <u>Ad</u> | <u>Name</u> | <u>New Setting</u> | <u>Ad</u> | <u>Name</u> | <u>New Setting</u> |
|-----------|-----------------|--------------------|-----------|------------------|--------------------|
| 06 | Replay Award | Credit | 17 | Backup Hi Scr 4 | 4,000,000 |
| 07 | Special Award | Credit | 18 | Hi Scr 1 Credits | 03 |
| 08 | Match Feature | 10 % | 19 | Hi Scr 2 Credits | 00 |
| 14 | Backup Hi Scr 1 | 5,500,000 | 20 | Hi Scr 3 Credits | 00 |
| 15 | Backup Hi Scr 2 | 5,000,000 | 21 | Hi Scr 4 Credits | 00 |
| 16 | Backup Hi Scr 3 | 4,500,000 | 24 | German 2 Coinage | 7 Plays/5DM |

57 Install German 5

The operator can modify the game pricing selection of Standard Setting 09 in the **Pricing Table** to permit Ticket/Token operation with 7 games for 5 DM. Individual Adjustments are affected, as follows:

| <u>Ad</u> | <u>Name</u> | <u>New Setting</u> | <u>Ad</u> | <u>Name</u> | <u>New Setting</u> |
|-----------|-----------------|--------------------|-----------|------------------|--------------------|
| 06 | Replay Award | Coil | 17 | Backup Hi Scr 4 | 4,000,000 |
| 07 | Special Award | Ball | 18 | Hi Scr 1 Credits | 03 |
| 08 | Match Feature | 10 % | 19 | Hi Scr 2 Credits | 00 |
| 14 | Backup Hi Scr 1 | 5,500,000 | 20 | Hi Scr 3 Credits | 00 |
| 15 | Backup Hi Scr 2 | 5,000,000 | 21 | Hi Scr 4 Credits | 00 |
| 16 | Backup Hi Scr 3 | 4,500,000 | 24 | German 2 Coinage | 7 Plays/5DM |

58 Install German 6

The operator can modify the game pricing selection of Standard Setting 09 in the **Pricing Table** to permit Keyset Mode operation with 7 games for 5 DM. Individual Adjustments are affected, as follows:

GAME ADJUSTMENT PROCEDURE (Continued)

58 Install German 6 (Continued)

| <u>Ad Name</u> | <u>New Setting</u> | <u>Ad Name</u> | <u>New Setting</u> |
|--------------------|--------------------|---------------------|--------------------|
| 06 Replay Award | Audit | 17 Backup Hi Scr 4 | 00 |
| 07 Special Award | Score | 18 Hi Scr 1 Credits | 00 |
| 08 Match Feature | Off | 19 Hi Scr 2 Credits | 00 |
| 14 Backup Hi Scr 1 | 00 | 20 Hi Scr 3 Credits | 00 |
| 15 Backup Hi Scr 2 | 00 | 21 Hi Scr 4 Credits | 00 |
| 16 Backup Hi Scr 3 | 00 | 24 German 2 Coinage | 7 Plays/5DM |

59 Install Add-A-Ball

The operator can utilize this option to delete all Free Play awards and replace them with Extra Ball awards. Individual Adjustments are affected, as follows:

| <u>Ad Name</u> | <u>New Setting</u> | <u>Ad Name</u> | <u>New Setting</u> |
|------------------|--------------------|---------------------|--------------------|
| 06 Replay Award | Ball | 18 Hi Scr 1 Credits | 00 |
| 07 Special Award | Ball | 19 Hi Scr 2 Credits | 00 |
| 08 Match Feature | Off | 20 Hi Scr 3 Credits | 00 |
| | | 21 Hi Scr 4 Credits | 00 |

60 Install 5 Ball

The operator can change the game to 5-Ball play, including the changing of certain features to the recommended 5-Ball play difficulty level. Individual Adjustments are affected, as follows:

| <u>Ad Name</u> | <u>New Setting</u> | <u>Ad Name</u> | <u>New Setting</u> |
|-----------------|--------------------|-----------------|--------------------|
| 02 Replay Start | 3,000,000 | 09 Balls / Game | 05 |

61 Install Novelty

The operator can remove all Free Play and Extra Ball awards. Individual Adjustments are affected, as follows:

| <u>Ad Name</u> | <u>New Setting</u> | <u>Ad Name</u> | <u>New Setting</u> |
|-------------------|--------------------|---------------------|--------------------|
| 01 Fixed Replay | SCORES | 07 Special Award | Score |
| 02 Replay Level 1 | Off | 08 Match Feature | Off |
| 03 Replay Level 2 | Off | 11 No Extra Ball | 00 |
| 04 Replay Level 3 | Off | 18 Hi Scr 1 Credits | 00 |
| 05 Replay Level 4 | Off | 19 Hi Scr 2 Credits | 00 |
| 06 Replay Award | Audit | 20 Hi Scr 3 Credits | 00 |
| | | 21 Hi Scr 4 Credits | 00 |

62 Install Extra Easy

The operator can change the game play difficulty adjustments to a combination that is extremely easy (sometimes called "liberal"). The Game Adjustment Setting Comparison Table, which follows these 70 individual Adjustments descriptions, lists the Adjustments and the settings that comprise the 'Extra Easy' group.

63 Install Easy

The operator can change the game play difficulty adjustments to a combination that is slightly easier than the Factory Settings. The Game Adjustment Setting Comparison Table, which follows these 70 individual Adjustments descriptions, lists the Adjustments and the settings that comprise the 'Easy' group.

GAME ADJUSTMENT PROCEDURE (Continued)

64 Install Medium

The operator can change the game play difficulty adjustments to a combination that matches the Factory Settings. The Game Adjustment Setting Comparison Table, which follows these 70 individual Adjustments descriptions, lists the Adjustments and the settings that comprise the 'Medium' group.

65 Install Hard

The operator can change the game play difficulty adjustments to a combination that is more difficult than the Factory Settings. The Game Adjustment Setting Comparison Table, which follows these 70 individual Adjustments descriptions, lists the Adjustments and the settings that comprise the 'Hard' group.

66 Install Extra Hard

The operator can change the game play difficulty adjustments to a combination that is much more difficult than the Factory Settings. The Game Adjustment Setting Comparison Table, which follows these 70 individual Adjustments descriptions, lists the Adjustments and the settings that comprise the 'Extra Hard' group.

67 Auto Burn-in

The operator can choose the YES option for this Special Preset Adjustment to perform certain automatic testing of the game, as used in the factory. It does not affect the game operation, but merely provides for a cyclic testing of most of the game's mechanisms.

68 Clear Coins

The operator can request the clearing of the coinage audits (Au 01 through 04) by selecting (via the Credit button) the YES option, as shown in the player 4 display. This adjustment zeroes the counters tallying the number of coins through each slot, the Paid Credits counter, and the Credits display.

After the YES option is displayed, the operator must press the ADVANCE button. The game then displays DONE to show that the coinage audits have been reset to zero.

69 Clear Audits

The operator can request the clearing of the non-coinage audits (Au 05 through 38) by selecting (via the Credit button) the YES option, as shown in the player 4 display. This Adjustment zeroes the counters tallying the remaining Audit factors. Please note that this does NOT affect the Automatic Replay Percentaging data nor the automatic High Score Reset counter.

After the YES option is displayed, the operator must press the ADVANCE button. The game then displays DONE to show that the non-coinage audits have been reset to zero.

70 Install Factory

The operator can request the game (via the Credit button) to provide the normal Factory Settings, essentially restoring the game to its 'factory condition'. The operator must select the 'YES' option for this adjustment. This Adjustment clears all Audits, resets all Game Adjustments to the respective Factory Settings, and provides a restart of the Auto Replay (Ad 01). After selecting the YES option, the operator must press the ADVANCE button. The game then displays FACTORY SETTING.

Closing of the coin door before appearance of the FACTORY SETTING message or a problem in the Memory Protect circuit will cause the game to display ADJUST FAILURE.

A loss of battery power or improper treatment of the Game Adjustments will cause the game to attempt to restore Factory Settings. The game announces the results of this reset process with the appropriate message, FACTORY SETTING or ADJUST FAILURE.

GAME ADJUSTMENT PROCEDURE (Continued)

CYCLONE Game Adjustment Setting Comparison Table

| Adj # | Adj Description | Extra Easy | Ad 62 | Easy | Ad 63 | Medium Ad (Factory) 64 | Hard | Ad 65 | Extra Hard | Ad 66 |
|-------|--------------------|---------------|----------|---------|----------|---------------------------|-----------|----------|---------------|----------|
| 31 | COMET Timer | 20 sec | | 20 sec | | 20 sec | 15 sec | | 15 sec | |
| 32 | Dbl Score Timer | 20 sec | | 20 sec | | 20 sec | 15 sec | | 10 sec | |
| 33 | Spookhouse Timer | 20 sec | | 20 sec | | 15 sec | 10 sec | | 10 sec | |
| 34 | Adv. X Timer | Off | | Off | | Off | 20 sec | | 15 sec | |
| 35 | CYCLONE Timer | 15 sec | | 20 sec | | 15 sec | 10 sec | | 10 sec | |
| 36 | Ferris Wheel Timer | Off | | 20 sec | | 15 sec | 15 sec | | 15 sec | |
| 37 | Million Timer | 20 sec | | 15 sec | | 10 sec | 10 sec | | 10 sec | |
| 38 | CYCLONE Memory | Ball St. Lit | | Mem Lit | | Mem Lit | Mem Unlit | | No Mem Unlit | |
| 39 | COMET Memory | Mem Lit | | Mem Lit | | Mem Lit | Mem Unlit | | No Mem Unlit | |
| 40 | Million _ Shots | 4 Shots | | 4 Shots | | 5 Shots | 6 Shots | | 6 Shots | |
| 41 | Ferris Bon. Adv. | 5K | | 5K | | 3K | 3K | | 2K | |
| 42 | Gate Bon. Adv. | 10K | | 10K | | 5K | 3K | | 2K | |
| 43 | Ex. Ball Auto Ad. | 33% | | 33% | | 33% | 25% | | 25% | |
| 44 | Ducks Ex. Ball | 3 Sets | | 3 Sets | | 3 Sets | 4 Sets | | 4 Sets | |
| 45 | Special Auto Ad. | 5% | | 5% | | 5% | 4% | | 3% | |
| 46 | Special ___X | 4X | | 4X | | 5X | 5X | | 5X | |
| 52 | Bonus Mult. Memory | Yes | | Yes | | Yes | No | | No | |

RESETTING THE HIGH SCORES

The challenge of exceeding the High Score (either the factory setting or a higher score by another player) is the goal of many pinball game players. To keep a pinball game challenging requires a method of resetting the High Score value for those occasions when a skilled player registers a truly excellent score. Other players note this score and may decide not to play simply because their skill is not adequate to exceed an extremely high score.

For *CYCLONE*, in fact, three methods of resetting the High Score values are available. The simplest method involves allowing Game Adjustment Item Ad 22 to reset the High Score values automatically after the specified number of plays designated by the operator. The second method requires pressing the High Score Reset switch on the inside of the coin door in the Attract Mode. This action simply erases the previous high score values and replaces them with the Backup High Score values. The third method establishes new values replacing the factory setting values or previous operator setting values; it requires performing the following steps:

1. Using AUTO-UP or MANUAL-DOWN, reach item Ad 14 (and items Ad 15, 16, and 17, if desired). The High Score value of the factory setting (or previous operator-adjusted setting) appears in the Player 1 display. If this value is satisfactory, go to step 4 below.
2. If you wish to increase the High Score value from that displayed in the Player 1 display, use AUTO-UP, and press the Credit button, until the desired value shows in the Player 1 display.
3. If you wish to decrease the High Score value, use MANUAL-DOWN, and press the Credit button, until the desired value shows in the Player 1 display.
4. Using AUTO-UP, press and hold down ADVANCE, until the Player 3 display shows **Ad 70**. Press ADVANCE once, to return to Game- Over Mode.
5. Press the High Score Reset switch (on coin door), and listen for the sound signifying that the score reset action is complete. Observe player score displays (Player 1, Player 2, etc.) to verify that the new High Score values are displayed.

GAME PRICING

PRICING MADE EASY. Game Adjustment Item Ad 24 allows the operator an easy method of setting the pricing functions. Pressing the Credit button allows the operator a choice of one of the 16 "Standard" Settings, with associated automatic pricing (Player 1 and 2 displays show the Country identifier, with a number for a country having more than one "Standard" Setting; player 3 and 4 displays show the games per coin(s) information). In the *Pricing Table*, each "Standard" Setting is denoted by a 2-digit number (other than 00) in column 24. Automatic Pricing causes each of the other pricing items (columns 25 through 30) to change to the value shown in the table for that selected "Standard" Setting.

CUSTOM PRICING. Adjustment Item 24 must be set to the Custom Coinage Setting (player 1 and 2 displaying CUSTOM COINAGE) to enable the operator to enter desired custom pricing selections for Items 25 through 30, based on the *Pricing Table*. Item 25 is the left coin chute multiplier. Item 26 is the center coin chute multiplier. Item 27 is the right coin chute multiplier. Item 28 is the number of coin units equal to one Credit. (A Credit is usually equal to one game.)

The calculation of the ratio of Games : Price uses the ratio equation of $X : VC$, where:

X = Coin Chute Multiplier (Item 25, 26, or 27 in *Pricing Table*);

V = Value of coin;

C = Coin units equivalent to one Credit (Item 28).

For example, for 25¢ chutes at the factory setting, substituting values in the Games : Price ratio calculation gives $1 : 25 \times 1$, or one game for 25¢.

UNITS REQUIRED FOR BONUS CREDIT. Item 29 is the number of coin units that must pass through the coin chute(s) before an additional Credit (game) is posted (displayed). At the factory setting, the number in this item is 00. (This 00 means that NO bonus credit (free game) is awarded, although purchase of more than one game at a time occurs.)

GAME PRICING (Continued)

MINIMUM COIN UNITS. Item 30 determines the number of coin units that must pass through the coin chute(s) before play may begin. The factory setting for this item is 00. (This 00 means that the Minimum Coin Units feature (Item 30) is disabled, by the factory setting.)

CYCLONE Pricing Table

| Country | Coin Chute | | | Games/Coin | Ad 24 Display | Pricing Functions | | | | | |
|------------------------|------------|---------|---------|--|---------------|-------------------|----|----|----|----|----|
| | Left | Center | Right | | | 25 | 26 | 27 | 28 | 29 | 30 |
| USA and Canada | 25¢ | - | 25¢ | 1/25¢, 4/\$1 ^{1,2} | U.S.A. 1 | 01 | 04 | 01 | 01 | 00 | 00 |
| | | | | 1/50¢, 2/75¢, 3/\$1 ² | U.S.A. 2 | 03 | 12 | 03 | 04 | 00 | 00 |
| | | | | 1/50¢, 2/\$1 ² | U.S.A. 3 | 01 | 04 | 01 | 02 | 00 | 00 |
| | | | | 1/25¢, 3/50¢, 6/\$1 | CUSTOM | 01 | 04 | 01 | 01 | 02 | 00 |
| | | | | 1/25¢, 5/\$1 | CUSTOM | 01 | 00 | 01 | 01 | 04 | 00 |
| West Germany | 1 DM | 2 DM | 5 DM | 1/1 DM, 2/2 DM, 7/5 DMark ^{2,3} | GERMAN2 | 06 | 12 | 30 | 05 | 30 | 00 |
| | | | | 1/1 DM, 3/2 DM, 10/5 DM ² | GERMAN1 | 09 | 18 | 45 | 05 | 45 | 00 |
| | | | | 1/1 DM, 3/2 DM, 9/5 DM | CUSTOM | 09 | 18 | 45 | 05 | 00 | 00 |
| | | | | 1/2x1 DM, 1/2 DM, 3/5 DM | CUSTOM | 03 | 06 | 15 | 05 | 00 | 00 |
| | | | | 2/1 DM, 5/2 DM, 14/5 DM | CUSTOM | 13 | 26 | 65 | 05 | 65 | 00 |
| | | | | Ticket/Token Mode ⁴ Keyset Mode ⁴ | CUSTOM | | | | | | |
| France | 1 F | 5 F | 10 F | 1/3x1 F, 2/5 F, 5/10 Franc ² | FRANCE | 02 | 10 | 20 | 05 | 20 | 00 |
| Antilles (Netherlands) | 25¢ | - | 1 G | 1/25¢, 4/1 Guilder | CUSTOM | 01 | 01 | 04 | 01 | 00 | 00 |
| Netherlands | 1 HFI | 2.5 HFI | 2.5 HFI | 1/1 HFI, 3/2.5 HFI ² | NETHERL. | 06 | 15 | 15 | 05 | 00 | 00 |
| | 25¢ | - | 1 G | 1/25¢, 5/1 Guilder | CUSTOM | 01 | 00 | 05 | 01 | 00 | 00 |
| Belgium | 20 F | 20 F | 20 F | 3/20 F ² | BELGIUM | 03 | 12 | 12 | 12 | 04 | 00 |
| | 5 F | - | 20 F | 1/2x5 F, 2/20 Franc | CUSTOM | 01 | 01 | 04 | 02 | 00 | 00 |
| | 5 F | 20 F | 20 F | 1/2x5 F, 2/20 F, 2/20 F | CUSTOM | 01 | 04 | 04 | 02 | 00 | 00 |
| | 5 F | 5 F | 20 F | 1/2x5 F, 1/2x5 F, 2/20 F | CUSTOM | 01 | 01 | 04 | 02 | 00 | 00 |
| Spain | 25 P | - | 100 P | 1/25 P, 5/100 Peseta ² | SPAIN | 01 | 00 | 05 | 01 | 00 | 00 |
| Switzerland | 1 F | - | 2 F | 1/1 F, 3/2 F ² | SWISS | 03 | 00 | 06 | 02 | 00 | 00 |
| | 1 F | 2 F | 5 F | 1/1 F, 3/2 F, 7/5 Franc | CUSTOM | 02 | 06 | 14 | 02 | 00 | 00 |
| Japan | - | 100 ¥ | - | 2/100 ¥ ² | JAPAN | 01 | 04 | 01 | 02 | 00 | 00 |
| | 100 ¥ | - | 100 ¥ | 2/100 Yen | CUSTOM | 04 | 00 | 04 | 02 | 00 | 00 |
| Italy | 500 L | - | 500 L | 1/500 Lire ² | ITALY | 01 | 04 | 01 | 01 | 00 | 00 |
| Australia | 20¢ | - | \$1 | 1/2x20 ¢, 3/\$1 ² | AUSTRAL. | 01 | 00 | 06 | 02 | 00 | 00 |
| United Kingdom | 10 P | 50 P | 10 P | 1/10 P, 5/50 P ² | U.K. | 01 | 05 | 01 | 01 | 00 | 00 |
| | 10 P | 50 P | 20 P | 1/10 P, 5/50 P, 2/20 Pence | CUSTOM | 01 | 05 | 02 | 01 | 00 | 00 |
| Argentina | 10¢ | 10¢ | 10¢ | 1/1 Token | CUSTOM | 01 | 01 | 01 | 01 | 00 | 00 |
| Austria | 5 Sch | 10 Sch | 10 Sch | 1/2x5 Sch, 3/2x10 Sch ² | AUSTRIA | 01 | 02 | 02 | 02 | 04 | 00 |
| | 5 Sch | - | 10 Sch | 2/5 Sch, 5/10 Schilling | CUSTOM | 02 | 00 | 05 | 01 | 00 | 00 |
| | 1 Sch | 5 Sch | 10 Sch | 2/5x1 Sch, 2/5 Sch, 5/10 Sch | CUSTOM | 02 | 10 | 25 | 05 | 00 | 00 |
| Chile | Token | - | Token | 1/1 Token ^{1,2} | U.S.A. 1 | 01 | 04 | 01 | 01 | 00 | 00 |
| Denmark | 1 Kr | 5 Kr | 10 Kr | 1/2x1 Kr, 3/5 Kr, 7/10 Krone | CUSTOM | 01 | 06 | 14 | 02 | 00 | 00 |
| Finland | 1 Mka | - | 1 Mka | 1/1 Markka ^{1,2} | U.S.A. 1 | 01 | 04 | 01 | 01 | 00 | 00 |
| New Zealand | 20¢ | - | 20¢ | 1/2x20¢ ² | U.S.A. 3 | 01 | 04 | 01 | 02 | 00 | 00 |
| Norway | 1 Kr | - | 1 Kr | 1/2x1 Kr, 3/5x1 Krone | CUSTOM | 01 | 00 | 01 | 02 | 05 | 00 |
| Sweden | 1 Kr | 5 Kr | 5 Kr | 1/3x1 Kr, 2/5 Krona ² | SWEDEN | 02 | 10 | 10 | 05 | 00 | 00 |
| | 1 Kr | - | 1 Kr | 1/2x1 Krona ² | U.S.A. 1 | 01 | 04 | 01 | 02 | 00 | 00 |

Notes: 1. Factory Default. 2. Standard Setting - Change by pressing Credit button. 3. Default with jumper W7 cut/removed. 4. Other functions are also affected; see the explanations for Adjustment Items 53 through 58.

TEST/DIAGNOSTIC PROCEDURES

WILLIAMS ELECTRONICS GAMES provides a series of diagnostic tests to aid the operator in determining game condition (that is, whether the game's features and highlights are operating satisfactorily). These tests activate virtually all the electronic and electromechanical devices comprising the game, so that the operator can readily locate a malfunctioning device or simply verify that all devices are working properly. In order, these tests deal with the music, the displays, the game sounds, the lamps, the solenoids, and the switches.

In addition to the diagnostic testing, a feature called the Auto Burn-in Mode is available. Activating this mode enables the operator to observe the game while all of the diagnostic tests, *except the switch test*, occur. This can be very helpful in locating 'intermittent' problems.

Activating either the entire test series or one of the individual tests requires use of the Game Adjustment/ Diagnostic switches. Open the coin door for access to these switches. To proceed to the Diagnostic Tests, the operator must simply switch the game On, set the AUTO-UP/MANUAL-DOWN switch to MANUAL-DOWN, and press the ADVANCE button.

CAUTION

*BIG GUN's System-11B game program greatly aids the operator and service personnel: At the beginning of the Test/Diagnostic Procedures (and also at game Turn-On), the Player 1 display now signals, with a decimal point by the rightmost character, that a switch has *NOT* been actuated during ball play for a lengthy period of time (120 balls, or ≈40 games). However, for the Switch Problem Reporting activity at the beginning of the Test/ Diagnostic Procedures, the display of problem switches is *not* limited to just three switches; it now includes *ALL* switches exhibiting problems. Refer to the text on Switch Tests for additional information. To proceed with the Test/Diagnostic Procedures, use AUTO-UP, and press ADVANCE.*

MUSIC TEST.

1. In the Music Test, observe that the player 1 and 2 displays show the message, MUSIC TEST. Switching to AUTO-UP, observe that the message now reads MUSIC OFF, and that the player 3 score display shows 00 00. Press the Credit button to select the desired music selection: 01 - 'Main Theme' through 06 - 'Hi. Score Theme' (the selections repeat). Adjust the volume control for proper sound level for the game location.
2. Use the AUTO-UP position.

DISPLAY TEST.

1. To initiate the Display Test, press ADVANCE. Observe that player 1 and 2 displays briefly show the message, DISPLAY TEST, and that the player 3 score display shows 01 (the Display Test identifier).
2. Use AUTO-UP. Observe that all displays begin a display cycle of all 0s through all 9s, one digit at a time. Verify that the proper comma segments light during display of the odd-numbered digits. Next, a special "all segments" character 'walks' from left to right across each player score display.
3. To halt the display cycle, use MANUAL-DOWN. Then, press ADVANCE to step through the sequential digit display, digit by digit, and the subsequent "all segments" characters display test. Use AUTO-UP to resume cycling, and to proceed to the next test.

SOUND TEST.

1. (From Display Test) To initiate the Sound Test, press ADVANCE. Observe that the player 1 and 2 displays show the message, SOUND TEST, and that the player 3 display shows 02 (the Sound Test identifier). The player 3 display shows a series of test steps from 00 through 07. Verify that a different sound is heard each time the number in the display changes.
2. To repeatedly pulse a single sound, use MANUAL-DOWN. Verify that one particular sound repeats. Press ADVANCE to step to the next sound, which repeats until ADVANCE is pressed again. Use AUTO-UP to resume cycling the sounds, and to proceed to the next test.

TEST/DIAGNOSTIC PROCEDURES

LAMP TESTS.

1. All Lamps.

(From Sound Test) To initiate the first Lamps Test, press ADVANCE. Observe that the Player 1 and 2 displays show the message, ALL LAMPS, and that the Player 3 display shows 03 (All LampsTest identifier) and that all feature lamps (playfield and backbox) blink on and off. (Note, however, that the General Illumination lamps remain lighted steadily.) To locate the wiring associated with a particular feature lamp, refer to the **Lamp-Matrix Table**. CPU Board connections at jacks 1J6 (columns) and 1J7 (rows) are also listed in the table.

2. Single Lamps.

From the All Lamps test, using AUTO-UP, press ADVANCE to initiate the Single Lamps Test. The Player 1 and 2 displays initially show the message, SINGLE LAMPS, and the Player 3 display shows 04. Then, the Player 3 display shows 04 01, and the Player 1 and 2 displays change to show HOLD, the name of the lamp currently blinking. Press the Credit button to proceed through an ascending series of designator numbers (01 through 64), with the Player 1 and 2 displays showing the individual lamp's name. Press and hold the Credit button to proceed rapidly to the desired lamp.

Backglass Lamps: 33 - 48 and 55 - 64

CYCLONE Lamp-Matrix Table

2 Two Lamps

Lamps = #44 Bulb, p/n 24-6549
555 Bulb, p/n 24-8768

| COLUMN ROW | 1 Q66 YEL-BRN 1J7-1 | 2 Q64 YEL-RED 1J7-2 | 3 Q62 YEL-ORN 1J7-3 | 4 Q60 YEL-BLK 1J7-4 | 5 Q58 YEL-GRN 1J7-6 | 6 Q56 YEL-BLU 1J7-7 | 7 Q54 YEL-VIO 1J7-8 | 8 Q52 YEL-GRY 1J7-9 |
|----------------------|----------------------------------|--|------------------------------|-----------------------------------|--|--|---------------------------|-------------------------------------|
| Q80 RED-BRN 1J6-1 | HOLD 1 | WL SCORE FERRIS WHEEL 2 BONUS 9 | RIDE AGAIN 17 | EXTRA BALL Left Outlane 25 | Mystery Wheel (tdc-top dead center) 33 | Mystery Wheel (180 deg from tdc) 41 | 2X 49 | 500,000 Bonus (Backglass)57 |
| Q81 RED-BLK 1J6-2 | BONUS 2 | ADV. "X" 10 | SPINS MYSTERY WHEEL 18 | EXTRA BALL Right Outlane 26 | Mystery Wheel (22-1/2 deg rt of tdc) 34 | Mystery Wheel (157-1/2 deg left of tdc) 42 | 7X 50 | 1,000,000 Bonus (Backglass)58 |
| Q82 RED-ORN 1J6-3 | DOUBLE 3 | Balloon 25K (Ducks) 11 | Ducks (top) 19 | COMET 20K 27 | Mystery Wheel (45 deg rt of tdc) 35 | Mystery Wheel (135 deg left of tdc) 43 | 6X 51 | 1,500,000 Bonus (Backglass)59 |
| Q83 RED-YEL 1J6-5 | SCORES 4 | Balloon 50K (Ducks) 12 | Ducks (mid) 20 | COMET 40K 28 | Mystery Wheel (67-1/2 deg rt of tdc) 36 | Mystery Wheel (112-1/2 deg left of tdc) 44 | 5X 52 | 2,000,000 Bonus (Backglass)60 |
| Q84 RED-GRN 1J6-6 | CYCLONE 50K 5 | Balloon LITES EX. BALL (Ducks) 13 | Ducks (bottom) 21 | COMET 60K 29 | Mystery Wheel (90 deg rt of tdc) 37 | Mystery Wheel (90 deg left of tdc) 45 | 4X 53 | 2,500,000 Bonus (Backglass)61 |
| Q85 RED-BLU 1J6-7 | CYCLONE 100K 6 | 1 (Gate Lane) 14 | Ball Toss (top) 22 | COMET 80K 30 | Mystery Wheel (112-1/2 deg rt of tdc) 38 | Mystery Wheel (67-1/2 deg left of tdc) 46 | 3X 54 | 3,000,000 Bonus (Backglass)62 |
| Q86 RED-VIO 1J6-8 | CYCLONE Gate Bonus 7 | 2 (Gate Lane) 15 | Ball Toss (mid) 23 | COMET 100K 31 | Mystery Wheel (135 deg rt of tdc) 39 | Mystery Wheel (45 deg left of tdc) 47 | MYSTERY (Backglass) 55 | 3,500,000 Bonus (Backglass)63 |
| Q87 RED-GRY 1J6-9 | RIDE THE COMET (on ramp) 8 | 3 (Gate Lane) 16 | Ball Toss (bottom) 24 | COMET 1 Million 32 | Mystery Wheel (157-1/2 deg rt of tdc) 40 | Mystery Wheel (22-1/2 deg left of tdc) 48 | WHEEL (Backglass) 56 | 4,000,000 Bonus (Backglass)64 |

TEST/DIAGNOSTIC PROCEDURES (Continued)

SOLENOID TEST.

1. (From Lamp Test) Using AUTO-UP, press ADVANCE. Observe that the Player 1 and 2 displays show the message, COIL TEST, the Player 3 display shows 05 (Solenoid Test identifier). Next, the Player 3 display shows a series of test steps from 01 through 22, while the Player 1 and 2 displays show the solenoid/circuit name. During each of these steps, pulsing of the respective solenoid/circuit occurs. The test cycles repeatedly, unless halted via the MANUAL-DOWN switch. Refer to the **Solenoid Table** for solenoid numbers and wiring information. CPU Board connections at 1P11, 1P12, and 1P19 are also listed in the table.

To continuously pulse a single solenoid/circuit, use MANUAL-DOWN. Press ADVANCE to sequence through the switched, controlled, and special solenoids. Use AUTO-UP to resume test cycling, and to proceed to the next test.

CYCLONE Solenoid Table

| Sol. No. | Solenoid Description <small>p = Playfield b = Backglass</small> | Solenoid Type | Wire Color ¹ | Connections | | Driver Trans. | Solenoid Part Number Flashlamp Type | |
|------------------|--|---------------|-------------------------|-------------|--|---------------|--|-----------------|
| | | | | CPU Bd. | Playfield/ Cabinet | | b = Backbox | p = Playfield |
| 01A ³ | Outhole Kicker | Switched | { Vio-Brn } | 1P11-1 | 8P3-1 (via 5J1-9, Aux Pwr Drvr Bd.) | Q33 | AE-23-800 | |
| 01C ³ | L F Wheel (p) & Jackpot (b) Flashers | Switched | { Blk-Brn } | (Gry-Brn) | | Q33 | #89 flashlamps | 2b,1p |
| 02A ³ | | Switched | { Vio-Red } | 1P11-3 | 8P3-2 (via 5J1-7, Aux Pwr Drvr Bd.) | Q25 | #89 flashlamps | 1b,1p |
| 02C ³ | R F Wheel (p) & Teeth (b) Flashers | Switched | { Blk-Red } | (Gry-Red) | | Q25 | #89 flashlamps | 1b,1p |
| 03A ³ | Ball Shooter Kickbig | Switched | { Vio-Orn } | 1P11-4 | 8P3-3 (via 5J1-6, Aux Pwr Drvr Bd.) | Q32 | AE-24-900 | |
| 03C ³ | Top mid (p) & L Eye (b) Flashers | Switched | { Blk-Orn } | (Gry-Orn) | | Q32 | #89 flashlamps | 1b,1p |
| 04A ³ | Boomerang Kickbig | Switched | { Vio-Yel } | 1P11-5 | 8P3-4 (via 5J1-5, Aux Pwr Drvr Bd.) | Q24 | AE-26-1500 | |
| 04C ³ | Cats (p) & lwr Fireworks (b) Flashers | Switched | { Blk-Yel } | (Gry-Yel) | | Q24 | #89 flashlamps | 1b,2p |
| 05A ³ | Drop Target | Switched | { Vio-Grn } | 1P11-6 | 8P3-5 (via 5J1-4, Aux Pwr Drvr Bd.) | Q31 | AE-23-800 | |
| 05C ³ | Ducks (p) & R Fireworks (b) Flashers | Switched | { Blk-Grn } | (Gry-Grn) | | Q31 | #89 flashlamps | 1b,2p |
| 06A ³ | | Switched | { Vio-Blu } | 1P11-7 | 8P3-6 (via 5J1-3, Aux Pwr Drvr Bd.) | Q23 | #89 flashlamps | 2p |
| 06C ³ | Ferris Wheel (p) Flashers | Switched | { Blk-Blu } | (Gry-Blu) | | Q23 | #89 flashlamps | 2p |
| 07A ³ | Knocker /Ticket Dispenser (b'box) | Switched | { Vio-Blk } | 1P11-8 | 8P3-7 (via 5J1-2, Aux Pwr Drvr Bd.) | Q30 | AE-26-1200 | |
| 07C ³ | Cyclone (p) & R Eye (b) Flashers | Switched | { Blk-Vio } | (Gry-Vio) | | Q30 | #89 flashlamps | 1b,1p |
| 08A ³ | | Switched | { Vio-Gry } | 1P11-9 | 8P3-8 (via 5J1-1, Aux Pwr Drvr Bd.) | Q22 | #89 flashlamps | 1b,1p |
| 08C ³ | Spook H'se (p) & L Fworks (b) Flashers | Switched | { Blk-Gry } | (Gry-Blk) | | Q22 | #89 flashlamps | 1b,1p |
| 09 | Spook House Bonus Flasher (p) | Contrlid | Brn-Blk | 1P12-1 | 8P3-9 (via 5J2-9) | Q17 | #89 flashlamps | 1p |
| 10 | Playfield Gen Illumin Relay (p) | Contrlid | Brn-Red | 1P12-2 | 8P3-10 (via 5J2-8) | Q9 | 5580-09555-01 ⁴ | |
| 11 | Backglass Gen Illumin Relay (b) | Contrlid | Brn-Orn | 1P12-4 | 6J3-1 (via 5J2-6) | Q16 | 5580-09555-01 ⁴ | |
| 12 | Solenoid A/C Select Relay (b) | Contrlid | Brn-Yel | 1P12-5 | 8P3-12 (via 5J2-5) | Q8 | 5580-09555-01 ⁵ | |
| 13 | Mystery Wheel (b) Coil B | Contrlid | Brn-Grn | 1P12-6 | 6J2-3 (B'box Conn Bd) | Q15 | 14-7948/D-12045 | |
| 14 | Mystery Wheel (b) Coil A | Contrlid | Brn-Blu | 1P12-7 | 6J2-4 | Q7 | 14-7948/D-12045 | |
| 15 | Boomerang Flashers (p) | Contrlid | Brn-Vio | 1P12-8 | 8P3-15 (via 5J2-2) | Q14 | #1251 lamps | 3p ⁶ |
| 16 | Ferris Wheel Motor/Relay (p) | Contrlid | Brn-Gry | 1P12-9 | 8P3-16 (via 5J2-1) | Q6 | 14-7941-3/5580-12145-01 | |
| 17 | Left Jet Bumper | Spec# 1 | Blu-Brn | 1P19-7 | 8P3-17 (via 5J3-7) | Q75 | AE-23-800 | |
| 18 | Left Kicker ("sling") | Spec# 2 | Blu-Red | 1P19-4 | 8P3-18 (via 5J3-6) | Q71 | AE-26-1500 | |
| 19 | Right Jet Bumper | Spec# 3 | Blu-Orn | 1P19-3 | 8P3-19 (via 5J3-3) | Q73 | AE-23-800 | |
| 20 | Right Kicker ("sling") | Spec# 4 | Blu-Yel | 1P19-6 | 8P3-20 (via 5J3-4) | Q69 | AE-23-800 | |
| 21 | Bottom Jet Bumper | Spec# 5 | Blu-Grn | 1P19-8 | 8P3-21 (via 5J3-2) | Q77 | AE-26-1500 | |
| 22 | | Spec# 6 | Blu-Blk | 1P19-9 | | Q79 | | |
| - | Right Flipper | - | Orn-Vio [Blu-Vio] | 1P19-1 | 7P1-15 [7P1-16,8P3-34] ² | - | FL11630-50VDC | |
| - | Left Flipper | - | Orn-Gry [Blu-Gry] | 1P19-2 | 7P1-18 [7P1-19,8P3-32] ² | - | FL11630-50VDC | |

Notes: 1. Wire colors, except flipper Orn-Vio and Orn-Gry, are ground connections (to coil terminal with unbanded end of diode). Flipper Orn-Vio and Orn-Gry wires connect from CPU Board to flipper switch. 2. Flipper connections shown in braces are from flipper switch to flipper coil. 3. "A" coils are pulsed, when Sol. 12 is de-energized; "B" coils are pulsed, with Sol. 12 energized. Wire colors in brackets are those from respective A and B terminals corresponding to the J1-terminal connection listed for the Aux Power Driver Bd., which controls the device pulsing by Sol. 12. 4. Relay is mounted on Relay Bd. p/n C-11998-1. 5. Relay is mounted on Aux Pwr Driver Bd. D-11813 in the backbox. 6. Relay is mounted on Relay Bd C-11902-1.

TEST/DIAGNOSTIC PROCEDURES (Continued)

"On" State Logic - Special Solenoid

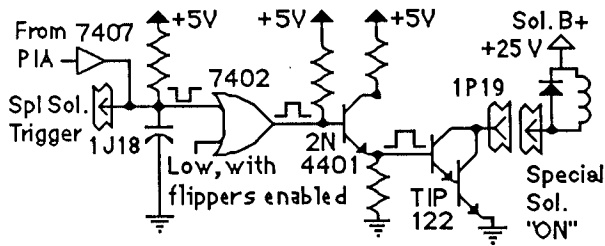

"On" State Logic - Controlled Solenoid

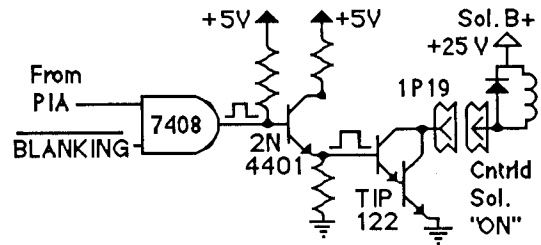

"Off" State - Special Solenoid:

The Special Switch Trigger Input goes low. Meanwhile, the PIA line remains high. The remaining signals reverse their states.

"Off" State - Controlled Solenoid:

The Enable Input (from the PIA) goes low. Meanwhile, the BLANKING signal remains high. The rest of the signals reverse their states.

NOTE

As directed by the game program, the Solenoid A/C Select Relay (solenoid 12) switches the solenoid B+ power between two power busses to permit actuating two groups of solenoids at the proper times. In its de-energized state, the Relay connects the 'circuit A power' to 16 "controlled" and "switched" solenoids (identified in the table with no suffix letter or the letter A, after the solenoid number). Individual solenoid operation then depends on the game program enabling the ground path for solenoid actuation via the driver transistor associated with each solenoid circuit. For example, the game program can actuate the Outhole Kicker solenoid (sol. 01A), via the driver transistor Q33.

When the game program determines that the Solenoid A/C Select Relay (sol. 12) must be energized, the relay connects 'circuit C power' to eight group C solenoids (01C through 08C). Now, driver transistor Q33 can actuate the Left Ferris Wheel (p/f) and Jackpot (bb) Flasher circuit (sol. 01C). Using this "multiplexing" technique, the same driver transistor can control actuation of two separate solenoid circuits.

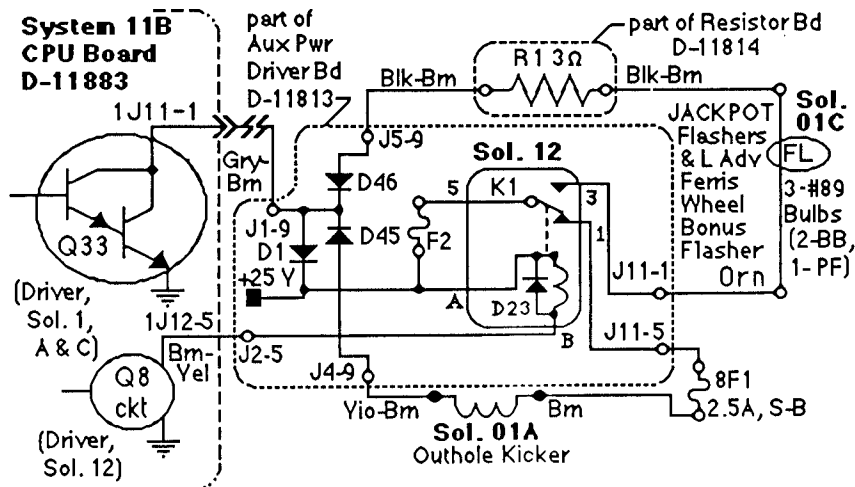

Typical *CYCLONE* +25V Circuit showing the Function of A/C Select Relay, Sol. 12

TEST/DIAGNOSTIC PROCEDURES (Continued)

SWITCH TESTS.

1. Switch Levels.

(From Solenoid Test) To initiate the Switch Levels Test, press ADVANCE. Observe that the Player 1 and 2 displays show the message, SWITCH LEVELS, and the Player 3 display shows 06 (Switch Levels Test identifier). Normally, the right portion of the Player 3 display remains blank, indicating that no switch is actuated.

If, however, a switch *is* actuated (possibly stuck closed), the Player 3 display shows that switch's number, while the Player 1 and 2 displays indicate the switch's name. A sound also accompanies the displays. (This is another facet of the *CYCLONE* System-11B's switch testing capability.) If more than one switch is closed, a series of displays show each actuated switch's name and number.

(In addition, either of these problems could result in the reporting of a switch problem (or problems) at game Turn-On or at the beginning of Diagnostic Tests.)

As soon as the operator opens a closed switch, its name and number are eliminated from the Switch Levels display series. For *CYCLONE*, switch numbers can range from 01 through 64. Refer to the **Switch-Matrix Table** for switch numbers and wiring information. CPU Board connections at jacks 1J8 (columns) and 1J10 (rows) are also listed in the table.

CYCLONE Switch-Matrix Table

| COLUMN ROW | 1 Q45 GRN-BRN 1J8-1 | 2 Q49 GRN-RED 1J8-2 | 3 Q44 GRN-ORN 1J8-3 | 4 Q48 GRN-YEL 1J8-4 | 5 Q43 GRN-BLK 1J8-5 | 6 Q47 GRN-BLU 1J8-7 | 7 Q42 GRN-VIO 1J8-8 | 8 Q46 GRN-GRY 1J8-9 |
|------------------------|---------------------------|---------------------------|-----------------------------|-----------------------------|---------------------------|---|------------------------------|---------------------------------|
| 1 WHT-BRN 1J10-9 | Plumb Bob Tilt 1 | Playfield Tilt 9 | Ferris Wheel Entrance 17 | Ball Shooter Lane 25 | Not Used 33 | Mystery Wheel Opto "Home" (Insert bd) 41 | Not Used 49 | Left Flipper Lane Change 57 |
| 2 WHT-RED 1J10-8 | Not Used 2 | Outhole 10 | Drop Target (center) 18 | Shuttle 10K (kickbig) 26 | Score CYCLONE 34 | Not Used 42 | Not Used 50 | Right Flipper Lane Change 58 |
| 3 WHT-ORN 1J10-7 | Credit Button 3 | Score Spook House 11 | Ducks (top) 19 | Shuttle 25K (bottom) 27 | 10 pt (R. Bottom) 35 | Not Used 43 | Not Used 51 | Spot Ball Toss 59 |
| 4 WHT-YEL 1J10-6 | Right Coin Chute 4 | Not Used 12 | Ducks (middle) 20 | Shuttle 100K 28 | 10 pt (R. Middle) 36 | Not Used 44 | Not Used 52 | Left Jet Bumper 60 |
| 5 WHT-GRN 1J10-5 | Center Coin Chute 5 | Boomerang Kickbig 13 | Ducks (bottom) 21 | Shuttle 25K 29 | 10 pt (R. Top) 37 | Not Used 45 | Left Outlane Ex. Ball 53 | Right Jet Bumper 61 |
| 6 WHT-BLU 1J10-3 | Left Coin Chute 6 | 1 Lane 14 | Ball Toss (top) 22 | Shuttle 5K (top) 30 | Not Used 38 | Not Used 46 | Right Outlane Ex. Ball 54 | Bottom Jet Bumper 62 |
| 7 WHT-VIO 1J10-2 | Slam Tilt 7 | 2 Lane 15 | Ball Toss (middle) 23 | Enter COMET Ramp 31 | Not Used 39 | Not Used 47 | Left Return Lane 55 | Left Kicker 63 |
| 8 WHT-GRY 1J10-1 | High-Score Reset 8 | 3 Lane 16 | Ball Toss (bottom) 24 | Score COMET Ramp 32 | Not Used 40 | Not Used 48 | Right Return Lane 56 | Right Kicker 64 |

Row Problems. If a display of two (or more) switch numbers of a row occurs, although only one switch is closed, check for a short circuit between the column wires.

Multiple Switch Number Indications. Check the associated column wire for a short circuit to ground.

Column Problems. If display of two (or more) switch numbers in a column occurs (while only one switch is actuated), check for a short circuit between the row wires.

Use AUTO-UP to proceed to the next test.

TEST/DIAGNOSTIC PROCEDURES (Continued)

SWITCH TESTS (Continued).

2. Switch Edges.

From the Switch Levels Test, press ADVANCE. Observe that the Player 1 and 2 displays show the message, SWITCH EDGES; the Player 3 display shows 07 (Switch Edges Test identifier). The right portion of the Player 3 display is blank, indicating that no switch is actuated.

This test permits the operator to test whether actuating a switch provides the proper signal to the System-11B switch testing program. When actuating a switch, the operator should see the switch's name and number (in the Player 1, 2, and 3 displays, respectively). If no indication appears at the time the switch is actuated, the operator then knows that there is a malfunction associated with that switch.

Using this technique, the operator can test each switch appearing in the *CYCLONE* switch problem reporting displays (either at game Turn-On or at the beginning of the Diagnostic Tests) to determine whether the switch can be actuated. If the switch's name and number are displayed while the operator checks its operation, the operator then knows that the reported problem with that switch is NOT currently caused by a switch malfunction. The operator can then seek other causes for the reported problem, being almost certain now that the switch did not fail. *This test is also useful when the operator is adjusting the sensitivity of a particular switch's actuation mechanism.*

Among the possibilities is the fact that the players have not actuated that switch because of some other problem; the operator should try to analyze what could cause the switch to be missed, and remedy that problem cause. With these new tests, switch problems are, therefore, more easily isolated.

3. *Playfield or CPU Board?* To determine whether a switch problem is in the playfield or the CPU Board, remove connectors 1P8 and 1P10 from the CPU Board. Begin the Switch Test. Use a jumper wire to simulate switch actuation. For example, placing a jumper between 1J10-9 and 1J8-2 should (based on the **Switch-Matrix Table**) should produce an indication of switch 09 being actuated.

MYSTERY WHEEL TEST

From the Switch Edges Test, press ADVANCE. Observe that the Player 1 and 2 displays show the message, WHEEL TEST, and that the Player 3 displays shows 08 (Mystery Wheel Test identifier).

The Player 2 display now shows the last known position of the Mystery Wheel, while the Player 4 display is divided to show the 'state' of the Home Switch. On the left of the Player 4 display, an "H" means that the Home Switch is open or the opto is interrupted; on the right, a number shows the count of the stepper wheel (1-200; however, if the Home Switch is not working, the number can go as high as 256). If the Player 3 Display shows 08__ (#), it is reporting the number of errors (#) for Mystery Wheel operation occurring since the last Game Turn-on.

Using AUTO-UP, the test is automatic: The wheel spins, waits for 2 seconds, then spins again. The wheel stops on the next counterclockwise position of the wheel, if the Home Switch works.

Using MANUAL-DOWN, press ADVANCE to spin the wheel. The wheel stops on the next counterclockwise position of the wheel, if the Home Switch works. If the wheel is not spinning, you can manually step the motor by pressing Credit button.

During the test, the Player 3 display shows 08Err (#) (Error numbers, up to 9, maximum), if errors occur (the game program did not detect the Home Switch). During a lengthy test, the Player 3 display will detect any errors and add them to the Err(#) count, so that the number displayed is the total number of errors detected during the test.

TEST/DIAGNOSTIC PROCEDURES (Continued)

ENDING THE DIAGNOSTIC TESTS.

To end the Diagnostic Tests, reach the Switch Edges Test (06 in the Player 3 display), use AUTO-UP and press ADVANCE. The backbox displays should show the *CYCLONE* game's Identification Information. Use MANUAL-DOWN, and press ADVANCE to reach Adjustment Item 70 (INSTALL FACTORY). Use AUTO-UP and press ADVANCE to obtain the Attract Mode.

AUTO BURN-IN MODE.

The Auto Burn-in Mode permits the operator to check intermittent (or nonrecurring) problems associated with most portions of the game's circuitry. Repeatedly cycling through a group of tests can sometimes bring a problem, which occurs only randomly or occasionally, to exhibit itself more frequently, thereby aiding in the isolation of the problem. To activate the Auto Burn-in Mode:

1. While in the Game Adjustments, reach Ad 67 and change the Factory Setting of NO to YES, via the Credit button. Set the AUTO-UP/MANUAL-DOWN switch to AUTO-UP.
2. Press ADVANCE to start the Auto Burn-in Mode. This mode repeatedly sequences through the Music Test, the Display Test, the Sound Test, the All Lamps portion of the Lamp Test, and the Solenoid Test.
3. To halt the Auto Burn-in Mode, switch the game Off and then On. *CYCLONE* now starts in the Attract Mode. (If a switch problem is now reported by the displays, perform the Switch Tests again to determine the nature of the problem; then, perform necessary repairs.)

SYSTEM-11B MEMORY CHIP TEST.

A new feature is now included in the Memory Chip Test for System 11B. During power-up, the CPU performs a self-testing routine. When all tests are satisfactory, the game proceeds to the Attract Mode, allowing players to use the game. Whenever a portion of the testing does not produce satisfactory results, the game displays a message, before proceeding to the next portion of the testing. ONLY after all tests are satisfactory does the game allow play.

In addition to the displayed message, when a test fails, the lower LED mounted on the CPU Board can be observed to determine the probable cause of the problem. The LED blinks, or flashes, a certain number of times to identify the probable cause, as described in the **CPU LED Indicator Codes Table**. The operator can also start the self-testing routine by pressing the CPU Diagnostic Switch (SW 2) on the edge of the CPU Board.

CPU LED Indicator Codes Table

| Diagnostic LED | | |
|---|--------------------|--|
| Blinks/ Flashes | Display Message | Explanation |
| 1 | U25 RAM FAILURE | U25 RAM could not be used properly (NO other tests are performed; the game is locked here, until the game is turned off). |
| 2 | MEM. PROT. FAILURE | This message means that (A) the Coin Door may be shut; (B) the Memory Protect Switch may be stuck in the ON position; (C) the memory protect logic is protecting the memory; or (D) a U25 RAM failure is occurring. (See Note 1) |
| 3 | U51 PIA FAILURE | U51 has a malfunction. (See Note 2) |
| 4 | U38 PIA FAILURE | U38 has a malfunction. (See Note 2) |
| 5 | U41 PIA FAILURE | U41 has a malfunction. (See Note 2) |
| 6 | U42 PIA FAILURE | U42 has a malfunction. (See Note 2) |
| 7 | U54 PIA FAILURE | U54 has a malfunction. (See Note 2) |
| 8 | U10 PIA FAILURE | U10 has a malfunction. (See Note 2) |
| 9 | IRQ FAILURE | IRQ has a malfunction. It may be missing or too fast or too slow. |
| 10 | U27 ROM FAILURE | U27's internal checksums do not match. It may be a ROM failure, or its associated connections and connecting devices are causing it to appear to have a problem. (The following U26 test is skipped.) |
| 11 | U26 ROM FAILURE | U26's internal checksums do not match. |
| Notes: 1. This test assumes that the Coin Door is OPEN; it is initiated ONLY by pressing the CPU Diagnostic Switch (SW2). 2. Alternatively, its associated connections or connecting devices are causing the IC to appear to have problems. | | |

TEST/DIAGNOSTIC PROCEDURES (Continued)

SYSTEM-11B SOUND CIRCUITRY TESTS.

Tests of the System-11B Sound circuitry, including the Audio Board are possible, only after successful completion of the System-11B Memory Chip Test.

- 1. Sound/Speech Board Test.** A brief check of the Audio Board (D-11581) circuitry occurs at game Turn-on; the game reports the test results by brief sounds, as follows: No sound = Sound/ Speech Board is not operating, or a failure is affecting the sound circuitry (broken cable; dead amplifier; etc.); 1 sound = system OK; 2 sounds = RAM problem; 3 sounds = U4 problem; 4 sounds = U19 problem.
- 2. General System-11B Sound Test.** Press the Sound Diagnostic Switch (SW 1) on left edge of the CPU Board. Listen for the two test sounds, showing that both the CVSD (Continuously Variable Slope Delta) Modulator, which provides the voices for *CYCLONE*, and the DAC (Digital-to-Analog Converter) sound circuits are functioning properly.

If no sound is heard, refer to the text entitled "NO SOUND ...". If one "ring" is heard, this indicates a malfunction of the U23 RAM Chip. If either two or four "rings" is heard, this indicates a problem associated with the U21 ROM Chip. If either three or five "rings" is heard, this indicates a problem with the U22 ROM Chip.

NO SOUND DURING THIS TEST (but sound can be heard during the Diagnostic Tests).

Check the sound-select inputs (pins 2 through 9 of U9) to see if they pulse during Sound Test 01. Also, check the -12 V supply voltage on the CPU Board. If this voltage is low (or AC ripple seems too high), perform the following checks:

1. The gray and gray-green transformer secondary wires for 19.4 VAC.
2. The CPU Board filter capacitor C26 for -12 VDC.
3. The filter capacitor C26 for excessive AC ripple (over 0.75VAC).

If the previous checks did not isolate the problem, turn the Volume Control for maximum output. Momentarily touch a powered-up AC soldering pencil on the center tap of the Volume Control.

CAUTION

DO NOT use a soldering iron over 40 watts. Note also that cordless soldering irons will NOT work for this test.

Hearing a low hum or a 'click' indicates that the power amplifier (U1, TDA2002), the Volume Control, and the speaker are operating satisfactorily, as is the sound circuit cabling. Not hearing a sound requires repeating the test with the Volume Control turned part way down, to determine whether the Volume Control is faulty. Also, check the cable connectors for proper mating, and that no broken wires affect this circuit .

FUSE LISTING.

The following fuses are used:

| Part Number | Description | Circuit/Location |
|---------------|--------------------------------|--|
| 5730-09252-00 | Fuse, 8A Slow-Blow (S-B), 125v | Input Power ("high voltage") Line/Cabinet Box* |
| 5731-09651-00 | Fuse, 5A S-B, 250v | Gen. Illumination/Upper Rt Backbox fuseholder (4) |
| 5730-09071-00 | Fuse, 8A S-B, 32v | +18 Vdc Lamp Ckt/ Lwr Rt Backbox fuseholder (1) |
| 5730-12203-00 | Fuse, 1/10A S-B, 250v | + & - 100V Display Pwr/Upr Cntr B'box fuseholder (2) |
| 5731-08665-00 | Fuse, 2A S-B, 250v | F1, F3 - F6; D-11813 Aux Pwr Driver Board |
| 5731-06314-00 | Fuse, 4A S-B, 250v | F2, F7; D-11813 Aux Pwr Driver Board |
| 5731-09651-00 | Fuse, 5A S-B, 250v | F8; D-11813 Aux Pwr Driver Board |
| 5731-08761-00 | Fuse, 1/4A S-B, 250v | F1, D-8345-557 Power Supply |
| 5731-09432-00 | Fuse, 7A S-B, 250v | F5, F6; D-8345-557 Power Supply |
| 5731-09128-00 | Fuse, 2-1/2A S-B, 250v | +25Vdc Solenoid "A" ckt/Mid P'fld fuseholder (1) |

* One 4A S-B, 250v fuse (5731-06314-00) is provided for an overseas (220v) game installation.

Section 2

Reference Diagrams & Schematics

- **Diagrams and Schematics:**

Switches

Lamps

Solenoids/Flashers & Rubber Parts

Cabinet Wiring

Power Supply Board

Aux Power Driver Board

Audio Board

A/N Display Unit Board

Interboards Signals

CPU Board

Controlled, Special, & Switched Solenoids

Power Wiring

Switches

| Item | Part No. | Description |
|------|----------------|---------------------------|
| 1 | A-8476 | Plumb Bob Tilt |
| 2 | Not Used | |
| 3 | SW-1A-126 | Credit Button |
| 4 | 27-1092 | R Coin Chute (USA) |
| 5 | Not Used (USA) | Center Coin Chute |
| 6 | 27-1092 | L Coin Chute (USA) |
| 7 | 27-1066 | Slam Tilt |
| 8 | 27-1008 | High Score Reset* |
| 9 | B-8306-1 | Playfield Tilt |
| 10 | 17-1067 | Outhole |
| 11 | 5647-12073-01 | Score Spook House |
| 12 | Not Used | |
| 13 | 5647-12073-09 | Boomerang Kickbig |
| 14 | 5647-12073-10 | 1 Gate/Lane |
| 15 | 5647-12073-10 | 2 Gate/Lane |
| 16 | 5647-12073-10 | 3 Gate/Lane |
| 17 | 5647-12073-10 | Ferris Wheel Entrance |
| 18 | C-11903-R | 1-bank Dr Tgt Opto |
| 19 | B-12039-5 | Duck target (top) |
| 20 | B-12039-5 | Duck target (mid) |
| 21 | B-12039-5 | Duck target (bottom) |
| 22 | B-11696-5 | Ball Toss target (top) |
| 23 | B-11696-5 | Ball Toss target (mid) |
| 24 | B-11696-5 | Ball Toss target (bottom) |
| 25 | 5647-12073-04 | Ball Shooter Lane |
| 26 | 5647-12133-01 | Shuttle 10K (kickbig) |
| 27 | 5647-12073-10 | Shuttle 25K (lower) |
| 28 | 5647-12073-10 | Shuttle 100K |
| 29 | 5647-12073-10 | Shuttle 25K (upper) |
| 30 | 5647-12073-10 | Shuttle 5K (topmost) |
| 31 | SW-1A-171 | Enter Comet Ramp |
| 32 | 5647-12133-04 | Score Comet Ramp |
| 33 | Not Used | |
| 34 | 5647-12133-07 | Score Cyclone (ramp) |
| 35 | B-4834-K | 10 pt (bottom right) |
| 36 | B-4834-K | 10 pt (mid right) |
| 37 | B-4834-K | 10 pt (top right) |

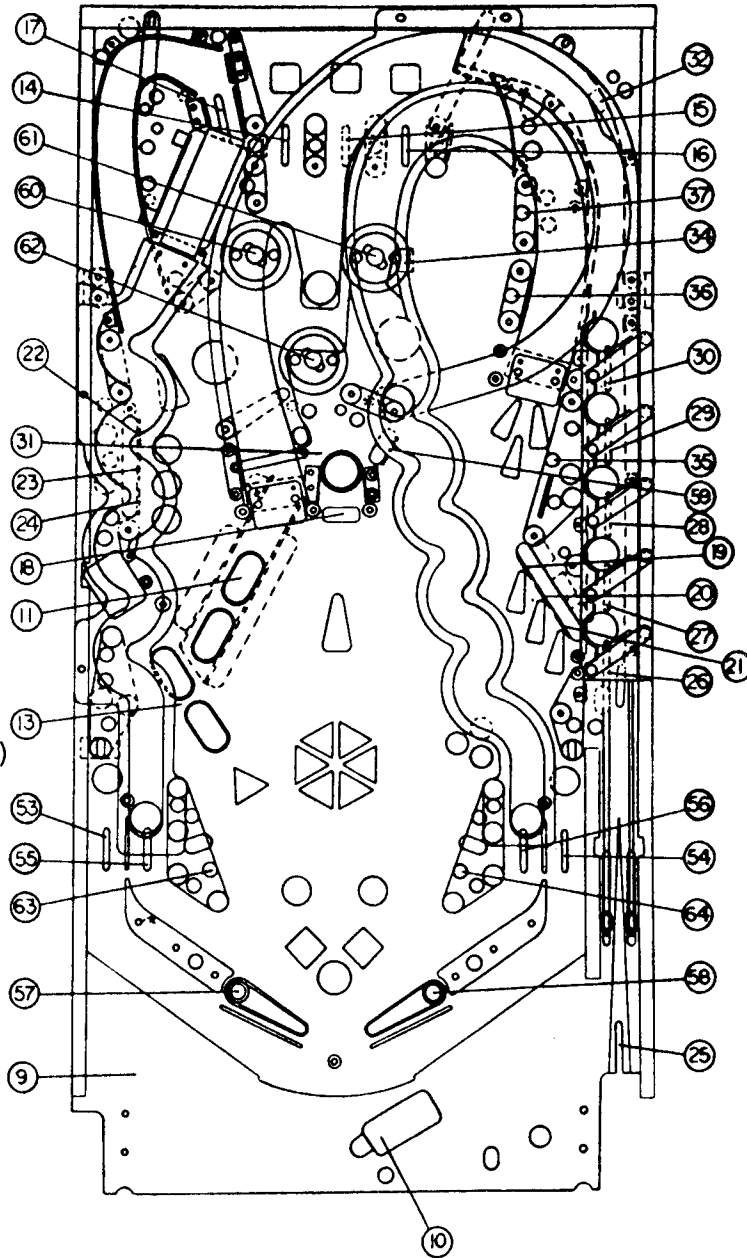

Mystery Wheel Opto**

| Item | Part No. | Description |
|------|---------------|--------------------------------|
| 54 | 5647-12073-10 | Right Outlane (drain) |
| 55 | 5647-12073-10 | Left Return Lane |
| 56 | 5647-12073-10 | Right Return Lane |
| 57 | B-9951-1 | L Flipper Lane Change |
| 58 | B-9951 | R Flipper Lane Change |
| 59 | B-12001-4 | Score Ball Toss Tgt |
| 60 | SW-11A-37 | Jet Bumper (left) |
| 61 | SW-11A-37 | Jet Bumper (right) |
| 62 | SW-11A-37 | Jet Bumper (bottom) |
| 63 | | Left Kicker*** |
| 64 | | Right Kicker*** |
| - | SW-10A-48 | Flipper Button (Cabinet sides) |

Notes: * Part Number is for entire Diagnostic Switch Assembly, including H S Reset Switch;

** Part of Motor Control Assy, D-12046; *** [Paired Kicker Actuating Sw: A-4834-H; B-8734-1]

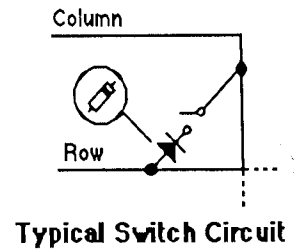
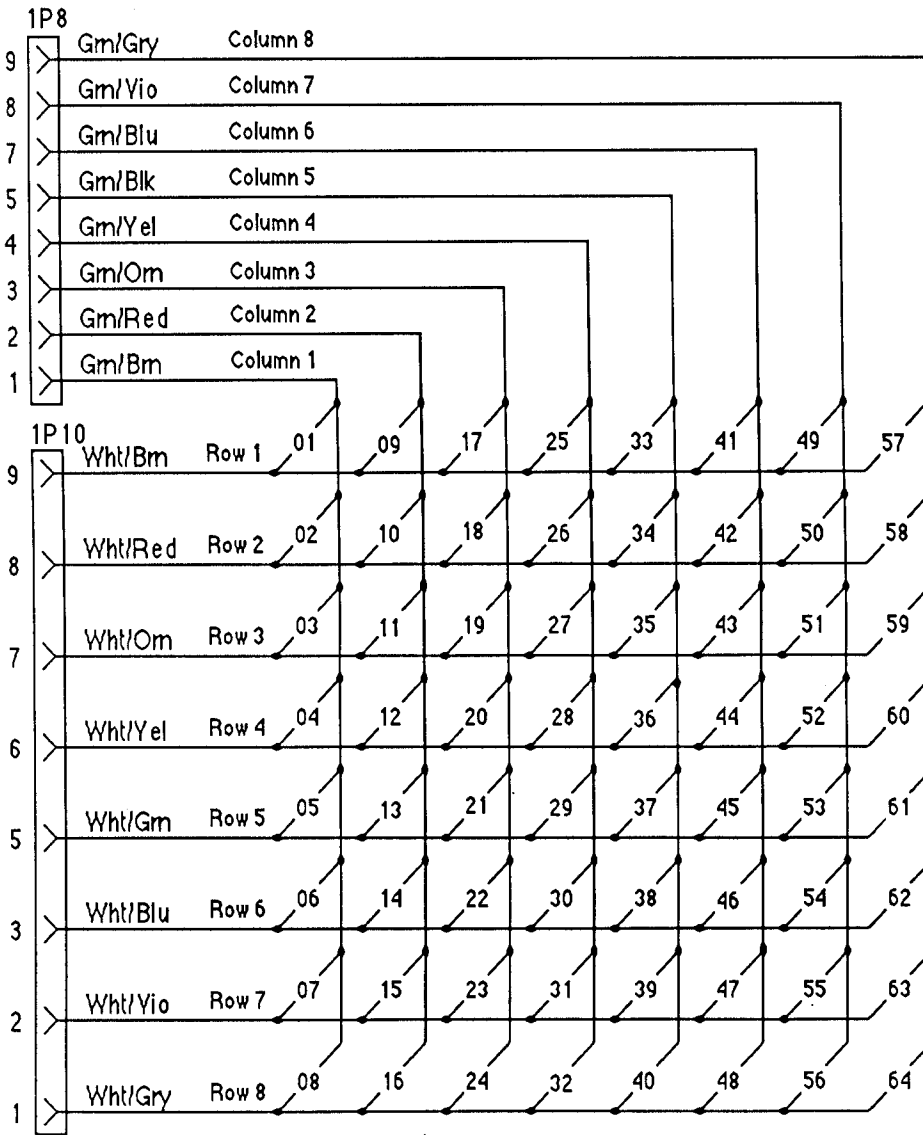

CYCLONE Switch-Matrix Table

| COLUMN \ ROW | 1 Q45 GRN-BRN 1J8-1 | 2 Q49 GRN-RED 1J8-2 | 3 Q44 GRN-ORN 1J8-3 | 4 Q48 GRN-YEL 1J8-4 | 5 Q43 GRN-BLK 1J8-5 | 6 Q47 GRN-BLU 1J8-7 | 7 Q42 GRN-VIO 1J8-8 | 8 Q46 GRN-GRY 1J8-9 |
|------------------------|---------------------------|---------------------------|-----------------------------|-----------------------------|---------------------------|---|------------------------------|---------------------------------|
| 1 WHT-BRN 1J10-9 | Plumb Bob Tilt 1 | Playfield Tilt 9 | Ferris Wheel Entrance 17 | Ball Shooter Lane 25 | Not Used 33 | Mystery Wheel Opto "Home" (Insert bd) 41 | Not Used 49 | Left Flipper Lane Change 57 |
| 2 WHT-RED 1J10-8 | Not Used 2 | Outhole 10 | Drop Target (center) 18 | Shuttle 10K (kickbig) 26 | Score CYCLONE 34 | Not Used 42 | Not Used 50 | Right Flipper Lane Change 58 |
| 3 WHT-ORN 1J10-7 | Credit Button 3 | Score Spook House 11 | Ducks (top) 19 | Shuttle 25K (bottom) 27 | 10 pt (R. Bottom) 35 | Not Used 43 | Not Used 51 | Spot Ball Toss 59 |
| 4 WHT-YEL 1J10-6 | Right Coin Chute 4 | Not Used 12 | Ducks (middle) 20 | Shuttle 100K 28 | 10 pt (R. Middle) 36 | Not Used 44 | Not Used 52 | Left Jet Bumper 60 |
| 5 WHT-GRN 1J10-5 | Center Coin Chute 5 | Boomerang Kickbig 13 | Ducks (bottom) 21 | Shuttle 25K 29 | 10 pt (R. Top) 37 | Not Used 45 | Left Outlane Ex. Ball 53 | Right Jet Bumper 61 |
| 6 WHT-BLU 1J10-3 | Left Coin Chute 6 | 1 Lane 14 | Ball Toss (top) 22 | Shuttle 5K (top) 30 | Not Used 38 | Not Used 46 | Right Outlane Ex. Ball 54 | Bottom Jet Bumper 62 |
| 7 WHT-VIO 1J10-2 | Slam Tilt 7 | 2 Lane 15 | Ball Toss (middle) 23 | Enter COMET Ramp 31 | Not Used 39 | Not Used 47 | Left Return Lane 55 | Left Kicker 63 |
| 8 WHT-GRY 1J10-1 | High-Score Reset 8 | 3 Lane 16 | Ball Toss (bottom) 24 | Score COMET Ramp 32 | Not Used 40 | Not Used 48 | Right Return Lane 56 | Right Kicker 64 |

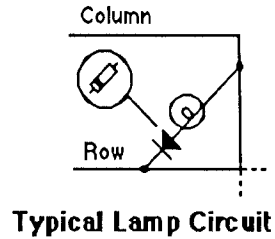
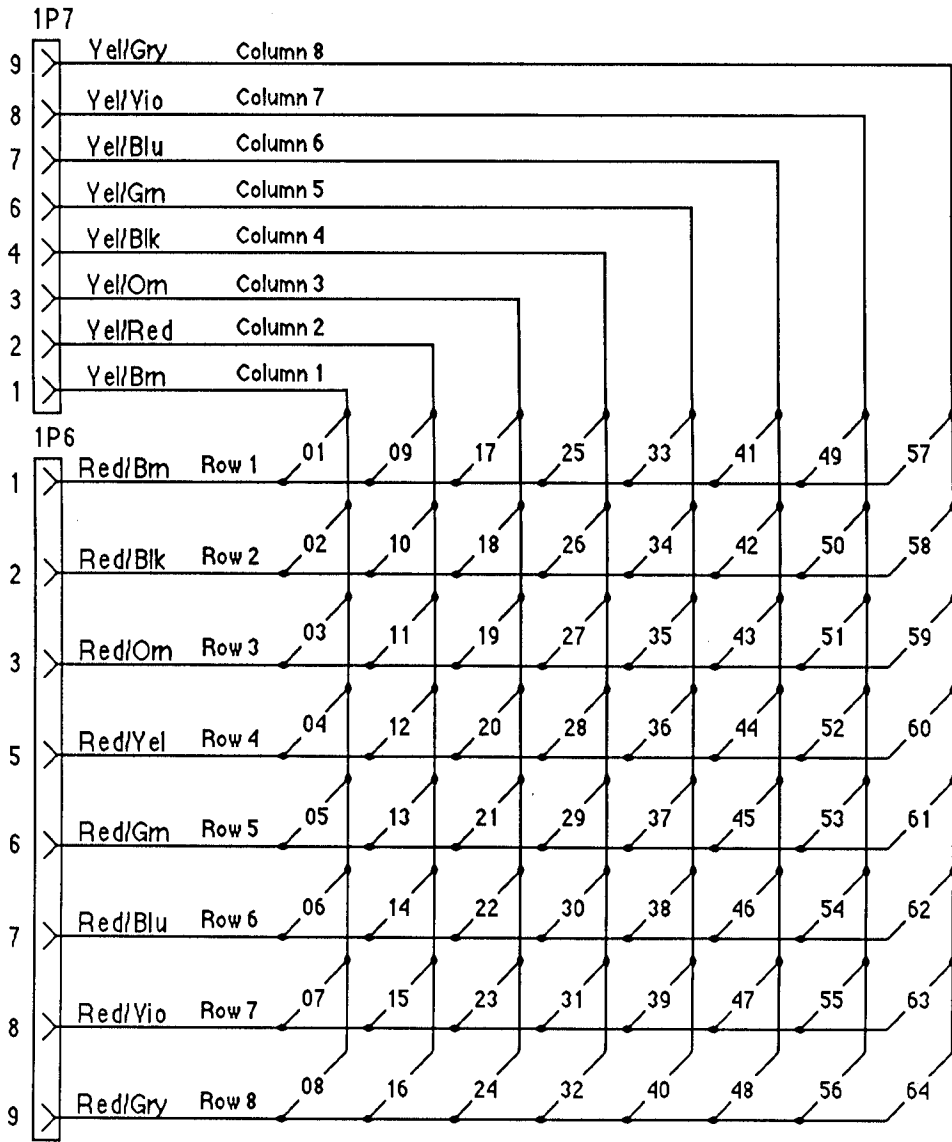

Backglass Lamps: 33 - 48 and 55 - 64

CYCLONE Lamp-Matrix Table

2 Two Lamps

Lamps = #44 Bulb, p/n 24-6549
555 Bulb, p/n 24-8768

| COLUMN \ ROW | 1 Q66 YEL-BRN 1J7-1 | 2 Q64 YEL-RED 1J7-2 | 3 Q62 YEL-ORN 1J7-3 | 4 Q60 YEL-BLK 1J7-4 | 5 Q58 YEL-GRN 1J7-6 | 6 Q56 YEL-BLU 1J7-7 | 7 Q54 YEL-VIO 1J7-8 | 8 Q52 YEL-GRY 1J7-9 |
|----------------------|----------------------------------|---|------------------------------|-----------------------------------|--|--|---------------------------|--------------------------------------|
| Q80 RED-BRN 1J6-1 | HOLD 1 | W/ SCORE FERRIS WHEEL 2 BONUS 9 | RIDE AGAIN 17 | EXTRA BALL Left Outlane 25 | Mystery Wheel (tdc-top dead center) 33 | Mystery Wheel (180 deg from tdc) 41 | 2X 49 | 500,000 Bonus (Backglass) 57 |
| Q81 RED-BLK 1J6-2 | BONUS 2 | ADV. " X" 10 | SPINS MYSTERY WHEEL 18 | EXTRA BALL Right Outlane 26 | Mystery Wheel (22-1/2 deg rt of tdc) 34 | Mystery Wheel (157-1/2 deg left of tdc) 42 | 7X 50 | 1,000,000 Bonus (Backglass) 58 |
| Q82 RED-ORN 1J6-3 | DOUBLE 3 | Balloon 25K (Ducks) 11 | Ducks (top) 19 | COMET 20K 27 | Mystery Wheel (45 deg rt of tdc) 35 | Mystery Wheel (135 deg left of tdc) 43 | 6X 51 | 1,500,000 Bonus (Backglass) 59 |
| Q83 RED-YEL 1J6-5 | SCORES 4 | Balloon 50K (Ducks) 12 | Ducks (mid) 20 | COMET 40K 28 | Mystery Wheel (67-1/2 deg rt of tdc) 36 | Mystery Wheel (112-1/2 deg left of tdc) 44 | 5X 52 | 2,000,000 Bonus (Backglass) 60 |
| Q84 RED-GRN 1J6-6 | CYCLONE 50K 5 | Balloon LITES EX. BALL (Ducks) 13 | Ducks (bottom) 21 | COMET 60K 29 | Mystery Wheel (90 deg rt of tdc) 37 | Mystery Wheel (90 deg left of tdc) 45 | 4X 53 | 2,500,000 Bonus (Backglass) 61 |
| Q85 RED-BLU 1J6-7 | CYCLONE 100K 6 | 1 (Gate Lane) 14 | Ball Toss (top) 22 | COMET 80K 30 | Mystery Wheel (112-1/2 deg rt of tdc) 38 | Mystery Wheel (67-1/2 deg left of tdc) 46 | 3X 54 | 3,000,000 Bonus (Backglass) 62 |
| Q86 RED-VIO 1J6-8 | CYCLONE Gate Bonus 7 | 2 (Gate Lane) 15 | Ball Toss (mid) 23 | COMET 100K 31 | Mystery Wheel (135 deg rt of tdc) 39 | Mystery Wheel (45 deg left of tdc) 47 | MYSTERY (Backglass) 55 | 3,500,000 Bonus (Backglass) 63 |
| Q87 RED-GRY 1J6-9 | RIDE THE COMET (on ramp) 8 | 3 (Gate Lane) 16 | Ball Toss (bottom) 24 | COMET 1 Million 32 | Mystery Wheel (157-1/2 deg rt of tdc) 40 | Mystery Wheel (22-1/2 deg left of tdc) 48 | WHEEL (Backglass) 56 | 4,000,000 Bonus (Backglass) 64 |

Lamps

Lamp Location/Description

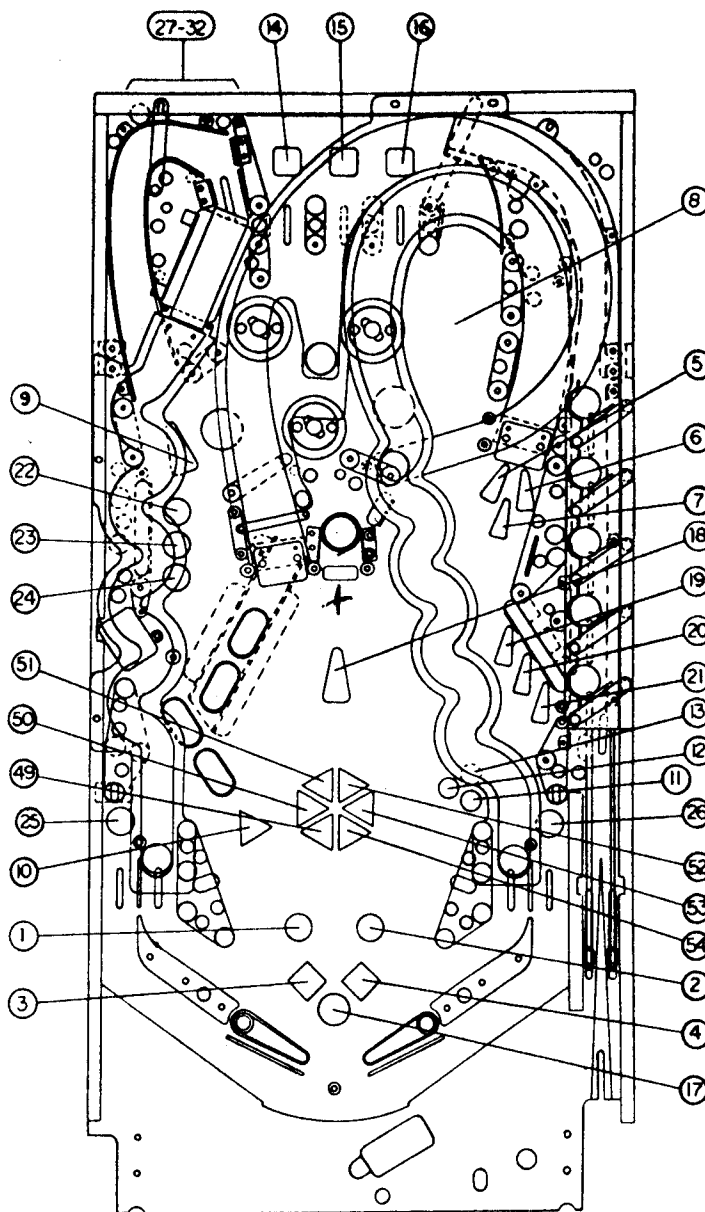

- 1 HOLD
- 2 BONUS
- 3 DOUBLE
- 4 SCORES
- 5 CYCLONE 50K
- 6 CYCLONE 100K
- 7 CYCLONE Gate Bonus
- 8 RIDE THE COMET (on ramp)
- 9 W/L SCORE FERRIS WHEEL BONUS
- 10 ADV. "X"
- 11 25K Balloon (Ducks)
- 12 50K Balloon (Ducks)
- 13 LITES EX. BALL Balloon (Ducks)
- 14 1 (Gate Lane)
- 15 2 (Gate Lane)
- 16 3 (Gate Lane)
- 17 RIDE AGAIN
- 18 SPINS MYSTERY WHEEL
- 19 Ducks (top)
- 20 Ducks (mid)
- 21 Ducks (bottom)
- 22 Ball Toss (top)
- 23 Ball Toss (mid)
- 24 Ball Toss (bottom)
- 25 EXTRA BALL (L Outlane)
- 26 EXTRA BALL (R Outlane)
- 27 COMET 20K
- 28 COMET 40K
- 29 COMET 60K
- 30 COMET 80K
- 31 COMET 100K
- 32 COMET 1 MILLION
- 33 Mystery Wheel (top)
- 34 Mystery Wheel (r of top 1)
- 35 Mystery Wheel (r of top 2)
- 36 Mystery Wheel (r of top 3)
- 37 Mystery Wheel (right)
- 38 Mystery Wheel (below right 1)
- 39 Mystery Wheel (below right 2)
- 40 Mystery Wheel (below right 3)
- 41 Mystery Wheel (bottom)
- 42 Mystery Wheel (l of bottom 1)
- 43 Mystery Wheel (l of bottom 2)
- 44 Mystery Wheel (l of bottom 3)
- 45 Mystery Wheel (left)
- 46 Mystery Wheel (above left 1)
- 47 Mystery Wheel (above left 2)
- 48 Mystery Wheel (above left 3)
- 49 2X
- 50 7X
- 51 6X
- 52 5X
- 53 4X
- 54 3X

Lamp Location/Description

- 55 MYSTERY (backglass)
- 56 WHEEL (backglass)
- 57 500,000 Bonus (backglass)
- 58 1,000,000 Bonus (backglass)
- 59 1,500,000 Bonus (backglass)
- 60 2,000,000 Bonus (backglass)
- 61 2,500,000 Bonus (backglass)
- 62 3,000,000 Bonus (backglass)
- 63 3,500,000 Bonus (backglass)
- 64 4,000,000 Bonus (backglass)

Solenoids/Flashers

| Item | Part No. | Description |
|------|-----------------|--------------------------------|
| 01A | AE-23-800 | Outhole Kicker |
| 01C | #89 Flashlamp | L F. Wheel (pf) & Jackpot (bb) |
| 02A | | |
| 02C | #89 Flashlamp | R F. Wheel (pf) & Teeth (bb) |
| 03A | AE-24-900 | Ball Shooter Kickbig |
| 03C | #89 Flashlamp | Top mid (pf) & L Eye (bb) |
| 04A | AE-26-1500 | Boomerang Kickbig |
| 04C | #89 Flashlamp | Cats (pf) & lwr Fireworks (bb) |
| 05A | AE-23-800 | Drop Target |
| 05C | #89 Flashlamp | Ducks (pf) & R Fireworks (bb) |
| 06A | | |
| 06C | #89 Flashlamp | Ferris Wheel (pf) |
| 07A | AE-26-1200 | Knocker (Ticket Dispenser) |
| 07C | #89 Flashlamp | Cyclone (pf) & R Eye (bb) |
| 08A | | |
| 08C | #89 Flashlamp | Sp'k Hse (pf) & L Fworks (bb) |
| 09 | #89 Flashlamp | Spins Mystery Wheel (pf) |
| 10 | 5580-09555-01 | P'field General Illumin Relay* |
| 11 | 5580-09555-01 | B'glass Gen. Illumin. Relay * |
| 12 | 5580-09555-01 | Solenoid A/C Select Relay** |
| 13 | | |
| 14 | | |
| 15 | #1251 Flashlamp | Boomerang Flasher |
| 16 | 5580-12145-01 | Ferris Wheel Motor/Relay*** |
| 17 | AE-23-800 | Left Jet Bumper |
| 18 | AE-26-1500 | Left Kicker ("Sling") |
| 19 | AE-23-800 | Right Jet Bumper |
| 20 | AE-26-1500 | Right Kicker ("Sling") |
| 21 | AE-23-800 | Bottom Jet Bumper |
| 22 | | |
| - | FL 11630-50VDC | Left and Right Flipper |

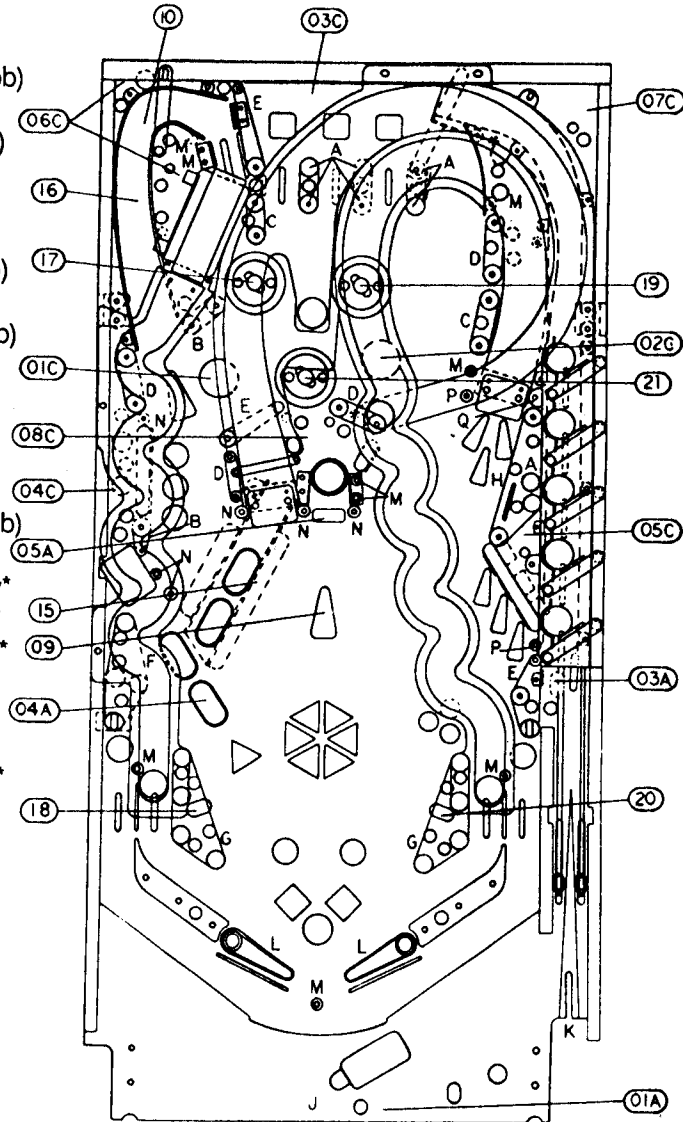

* - On Relay Board, C-11998-1

** - In backbox on Aux Power Driver Bd, D-11813

*** - On Relay Board, C-11902-1; Motor p/n 14-7941-3

Rubber Parts

| Item | Part No. | Description | Qty | Item | Part No. | Description | Qty |
|------|----------|-------------|-----|------|-----------|--------------------|-----|
| A | 23-6300 | 5/16" Ring | 7 | J | 23-6313-1 | Grommet | 1 |
| B | 23-6301 | 3/4" Ring | 2 | K | 23-6327 | Ball Shooter Tip | 1 |
| C | 23-6302 | 1" Ring | 2 | L | 23-6519-4 | Red Flipper Ring | 2 |
| D | 23-6303 | 1-1/4" Ring | 6 | M | 23-6535 | Bumper | 9 |
| E | 23-6304 | 1-1/2" Ring | 3 | N | 23-6552 | Sleeving | 6 |
| F | 23-6305 | 2" Ring | 1 | P | 23-6556 | Sleeving, Black | 2 |
| G | 23-6306 | 2-1/2" Ring | 2 | Q | 23-6579 | Bumper, 3/4" Taper | 1 |
| H | 23-6307 | 3" Ring | 1 | | | | |

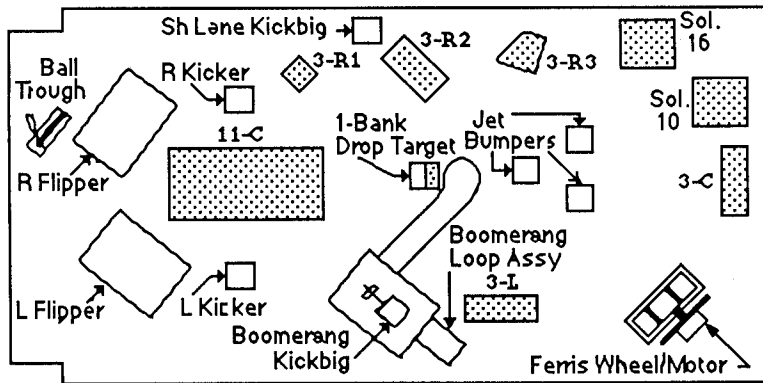

(underside of playfield)

Locations: { **Playfield Circuit Boards** [shaded square]
Major Mechanisms [square]

(Left to right from ball trough area)

| | | | |
|-------------|------------------------------|------------------|--------------------------------|
| C-11626-R-4 | Lower Right Flipper Assembly | B-11984 | Boomerang Loop Assembly |
| C-11626-L-4 | Lower Left Flipper Assembly | C-11866 | 3-Lamp PC Bd ("3-R2") |
| B-9463 | Right Kicker | C-11903-R | 1-b Drop Target Opto Assembly |
| D-11999 | 11-Lamp PC Bd ("11-C") | C-11866 | 3-Lamp PC Bd ("3-L") |
| B-9463 | Left Kicker | C-12004 | 3-Lamp PC Bd ("3-R3") |
| C-12005 | 3-Lamp PC Bd ("3-R1") | B-9414-1/B9415-1 | Jet Bumper(s)/Coil(s) |
| B-11051-R | Shooter Lane Kickbig | C-11902-1 | F. Wheel Relay PC Bd (Sol. 16) |
| B-11052 | Kickbig Mounting Assembly | C-11900 | Ferris Wheel /Motor Assembly |
| B-11051-R | Boomerang Kickbig | C-11998-1 | Relay PC Bd (Sol. 10) |
| B-11052 | Kickbig Mounting Assembly | C-12000 | 3-Lamp PC Bd ("3-C") |

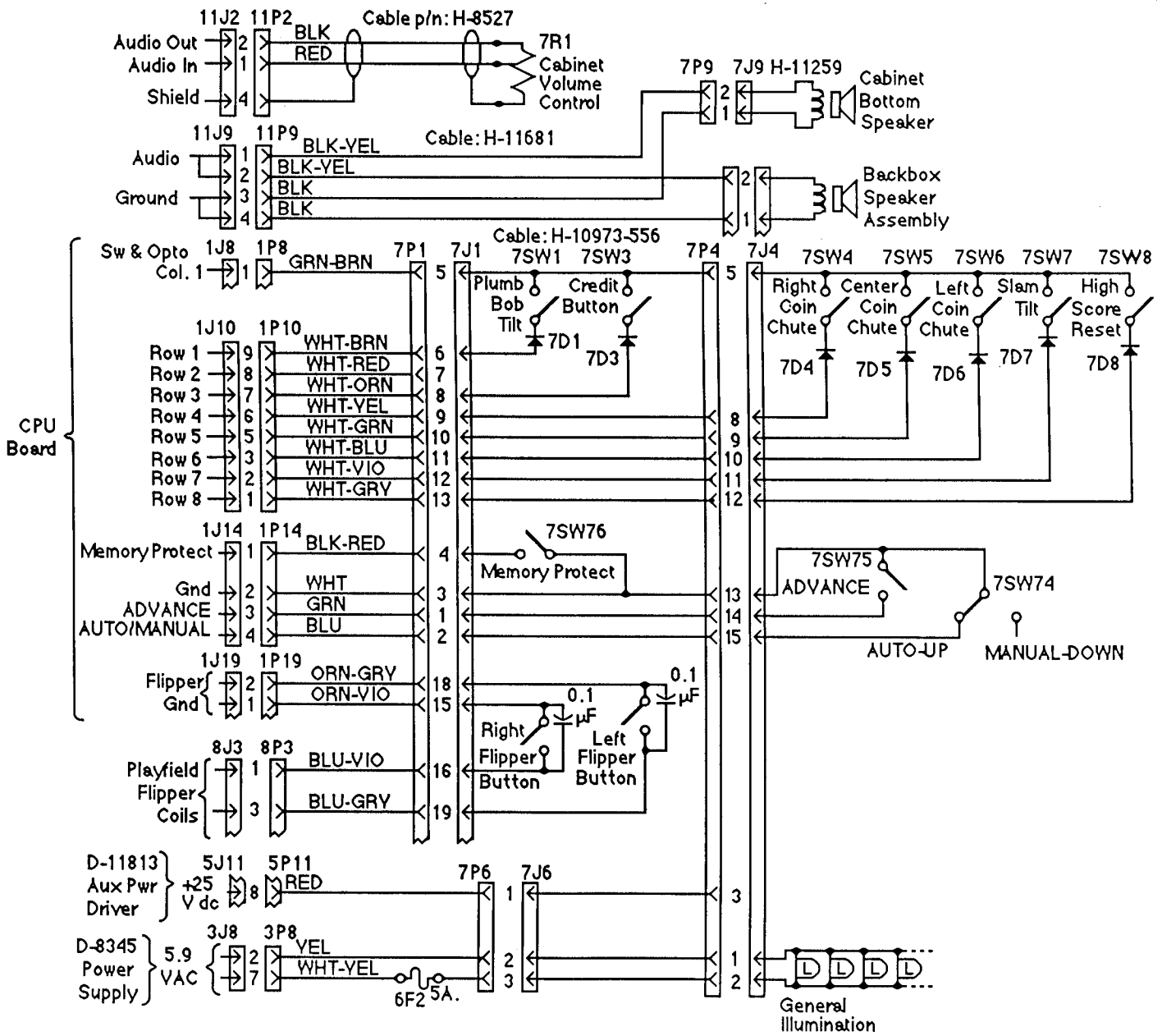

Cabinet Wiring Diagram

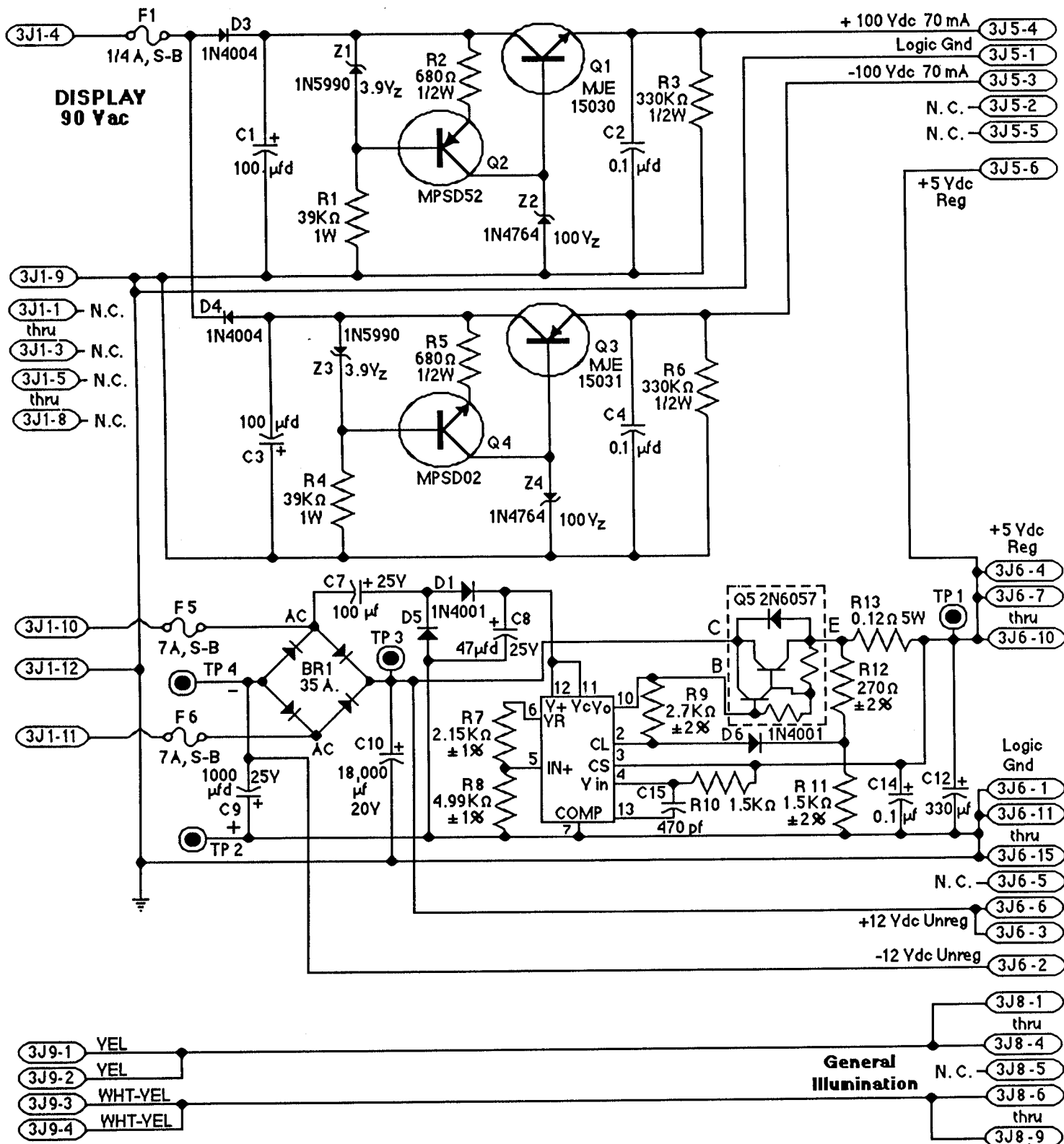

NOTES:

1. Display voltage measured with digits display test ON, and displays at all zeroes.
2. Unless otherwise indicated, all resistors are in ohms (Ω), 1/4 watt.
3. TP3 (unregulated +12 VDC) readout should not go lower than +10.5 V, or intermittent reset will occur.

D-8345-557 Power Supply Schematic

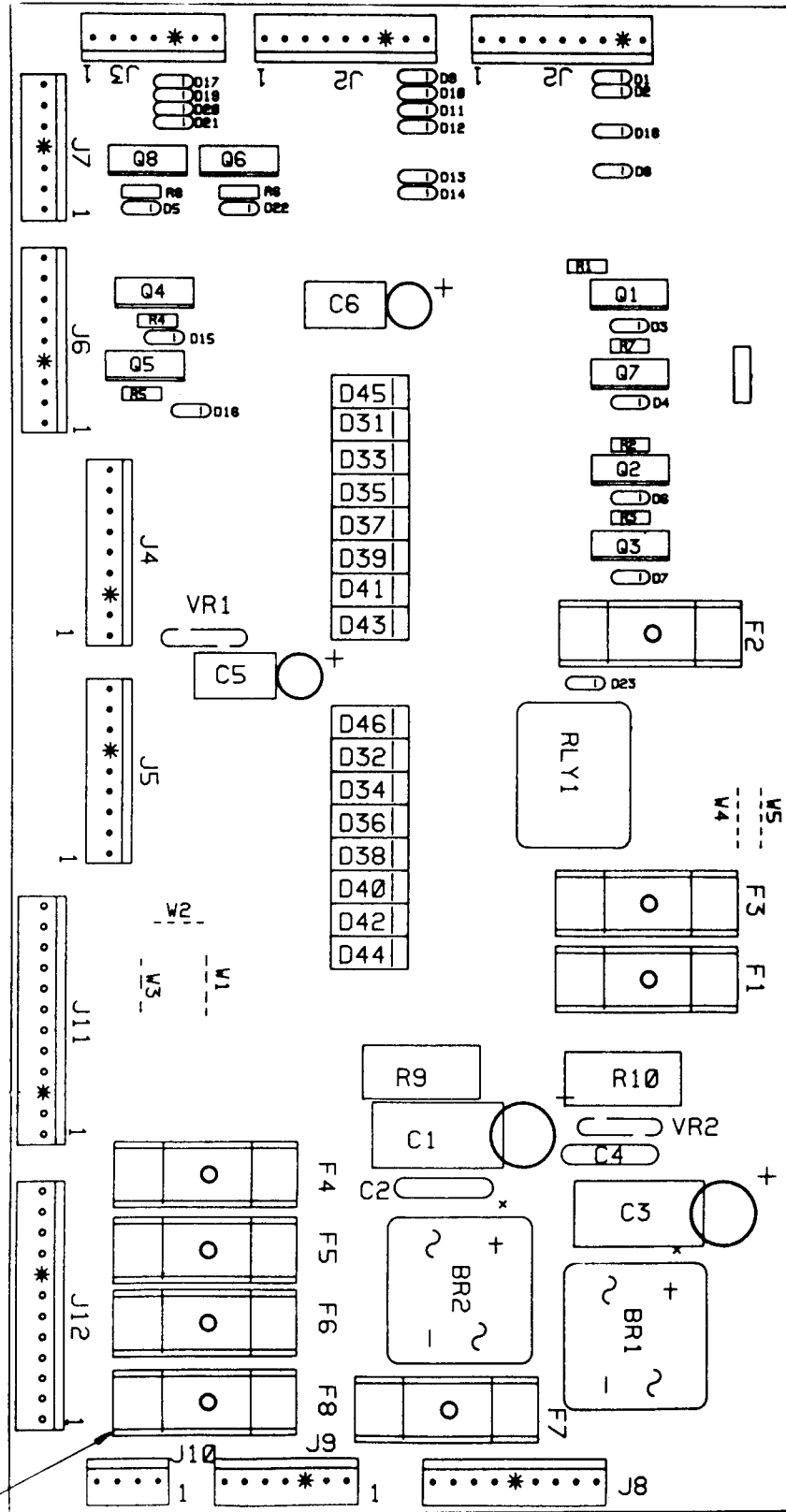

Aux Power Driver Board, D-11813

CYCLONE 44

| REV | DESCRIPTION OF CHANGE | ECN NO DATE |
|-----|-----------------------|------------------|
| | N. P. R. | 17886 8-19-87 |

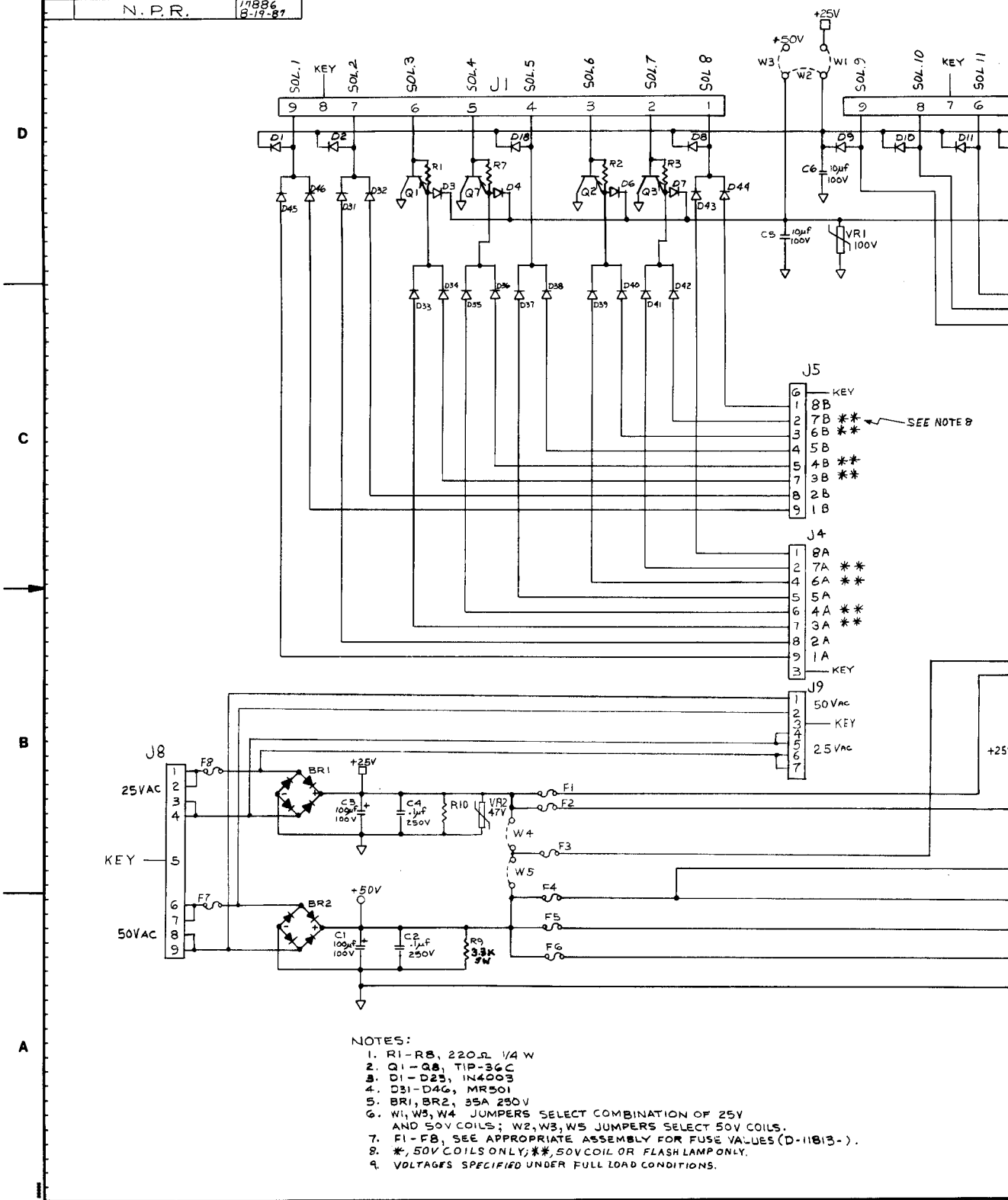

- NOTES:
1. R1-R8, 220Ω 1/4 W
 2. Q1-Q3, TIP-36C
 3. D1-D23, 1N4003
 4. D31-D46, MR501
 5. BR1, BR2, 35A 250V
 6. W1, W3, W4 JUMPERS SELECT COMBINATION OF 25V AND 50V COILS; W2, W3, W5 JUMPERS SELECT 50V COILS.
 7. F1-F8, SEE APPROPRIATE ASSEMBLY FOR FUSE VALUES (D-11813-).
 8. *, 50V COILS ONLY; **, 50V COIL OR FLASH LAMP ONLY.
 9. VOLTAGES SPECIFIED UNDER FULL LOAD CONDITIONS.

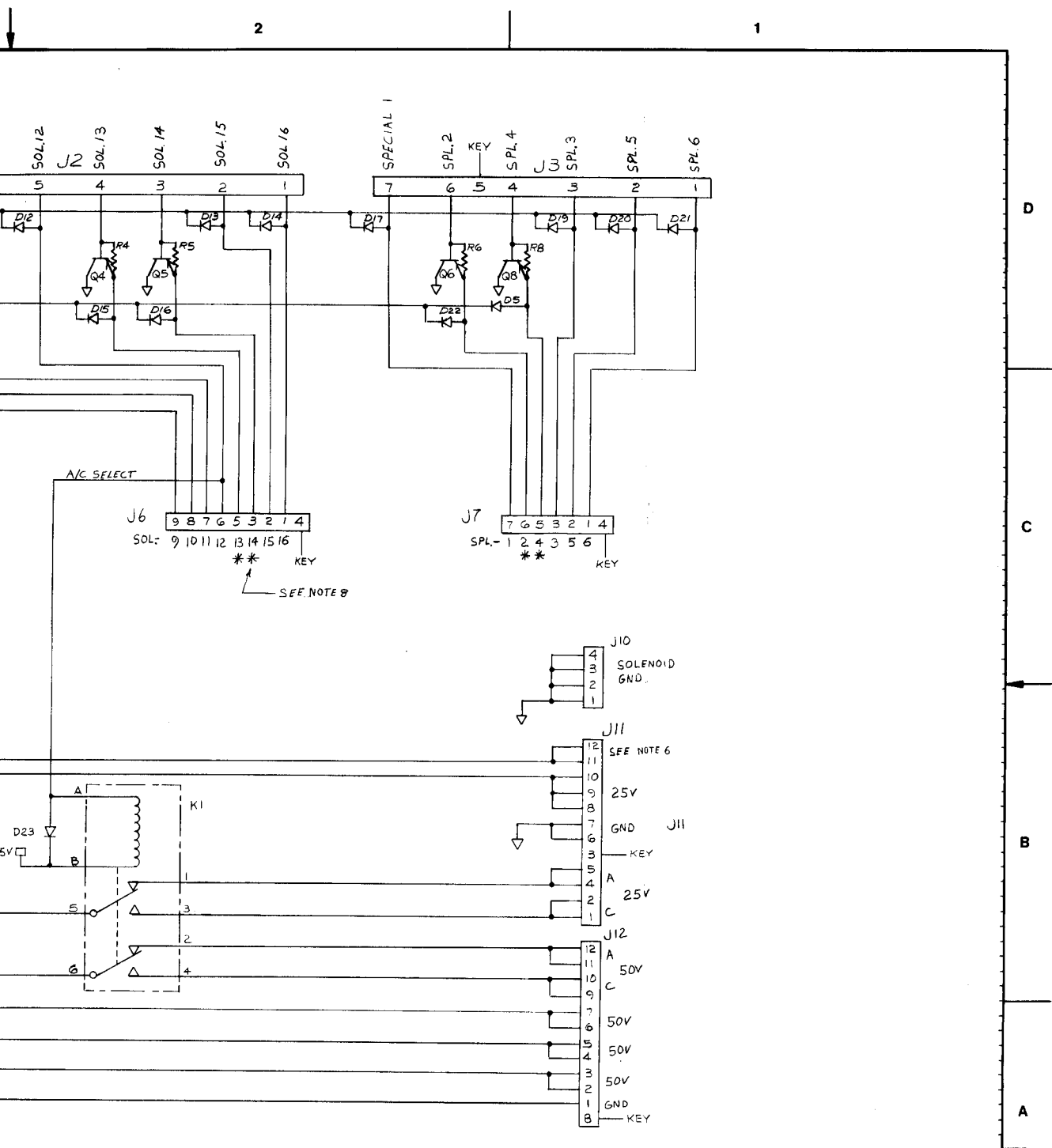

| ITEM | PART NUMBER | DESCRIPTION | QTY | ITEM | PART NUMBER | DESCRIPTION | QTY |
|---------------------------------------|-------------|--|-----|---|-------------|--|-----|
| PROJ. ENGR K. DEGER | | DO NOT SCALE WORK TO DIMENSIONS SHOWN | | REMOVE BURRS-BREAK SHARP CORNERS & EDGES | | WILLIAMS ELECTRONICS, INC. | |
| DWN BY DATE ROSS 7-7-87 | | TOLERANCES DECIMAL — X ± 0.30 ANGULAR — ± 1/2° XX ± 0.05 FRACTIONAL ± 1/64 | | 3401 N. CALIFORNIA AVE. CHICAGO, IL. 60618 | | NAME SCHEMATIC - AUX. PWR. DRVR. | |
| CHECKED BY DATE [Signature] 8/1/67 | | FIRST PROJECT NO. 557 | | MATERIAL —H— | | SCALE N/S | |
| APPROVAL DATE [Signature] 8/1/67 | | FIRST USAGE 557-BB | | QTY 1 | | SHT. 1 OF 1 PART NO. 16-9015 REV | |

Aux Power Driver Board Schematic

| REV | DESCRIPTION OF CHANGE | ECN NO | DATE |
|-----|-----------------------|--------|---------|
| | N. P. R. | 16726 | 2-27-87 |

D
C
B
A

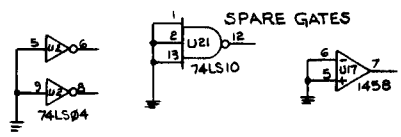
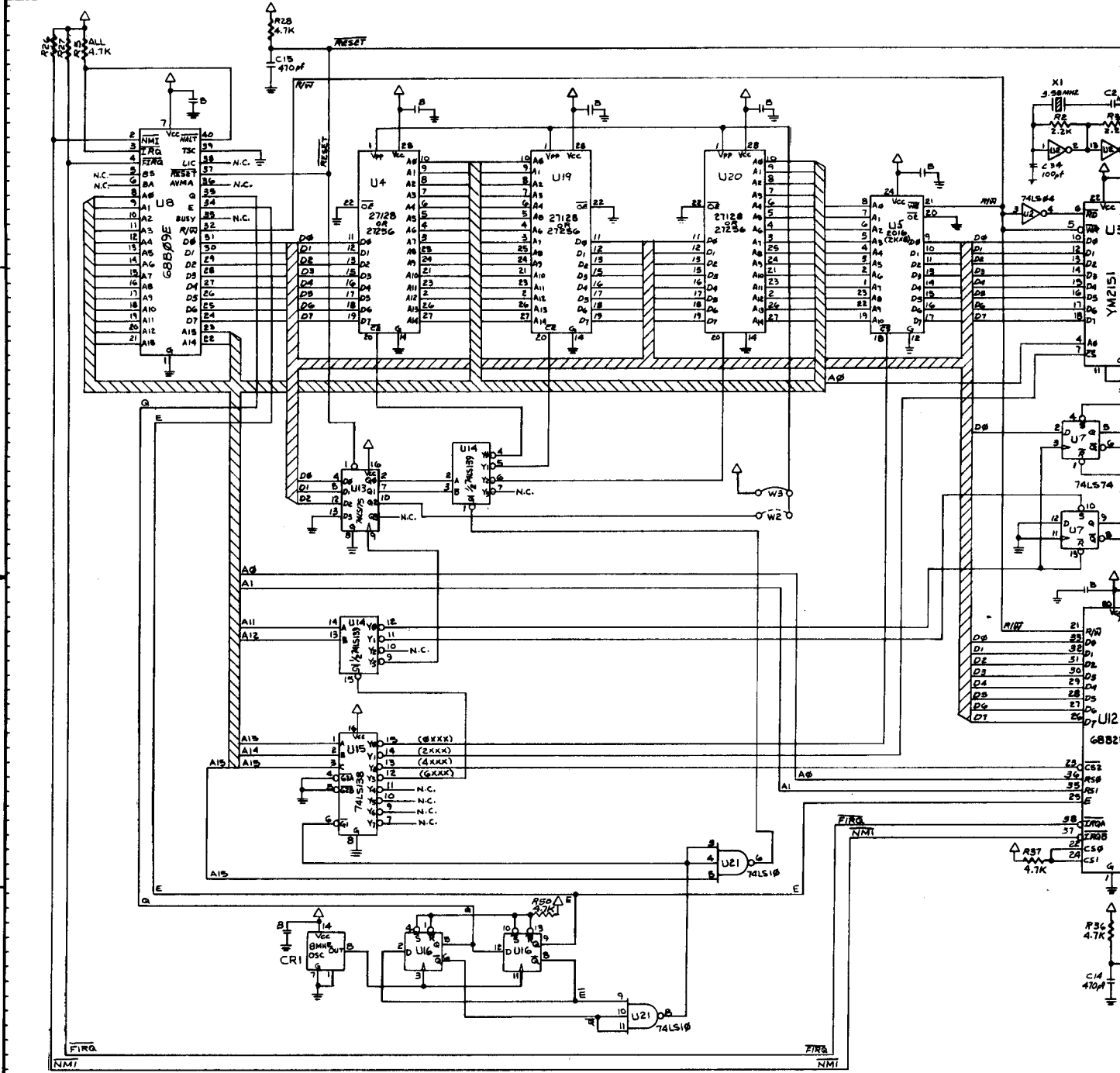

NOTES:
 - ALL CAPACITORS WITH "B" ARE BYPASS AND HAVE A VALUE OF .01µF.
 - LAST USED C59, R48, U23, W7, J5, L3.

4

3

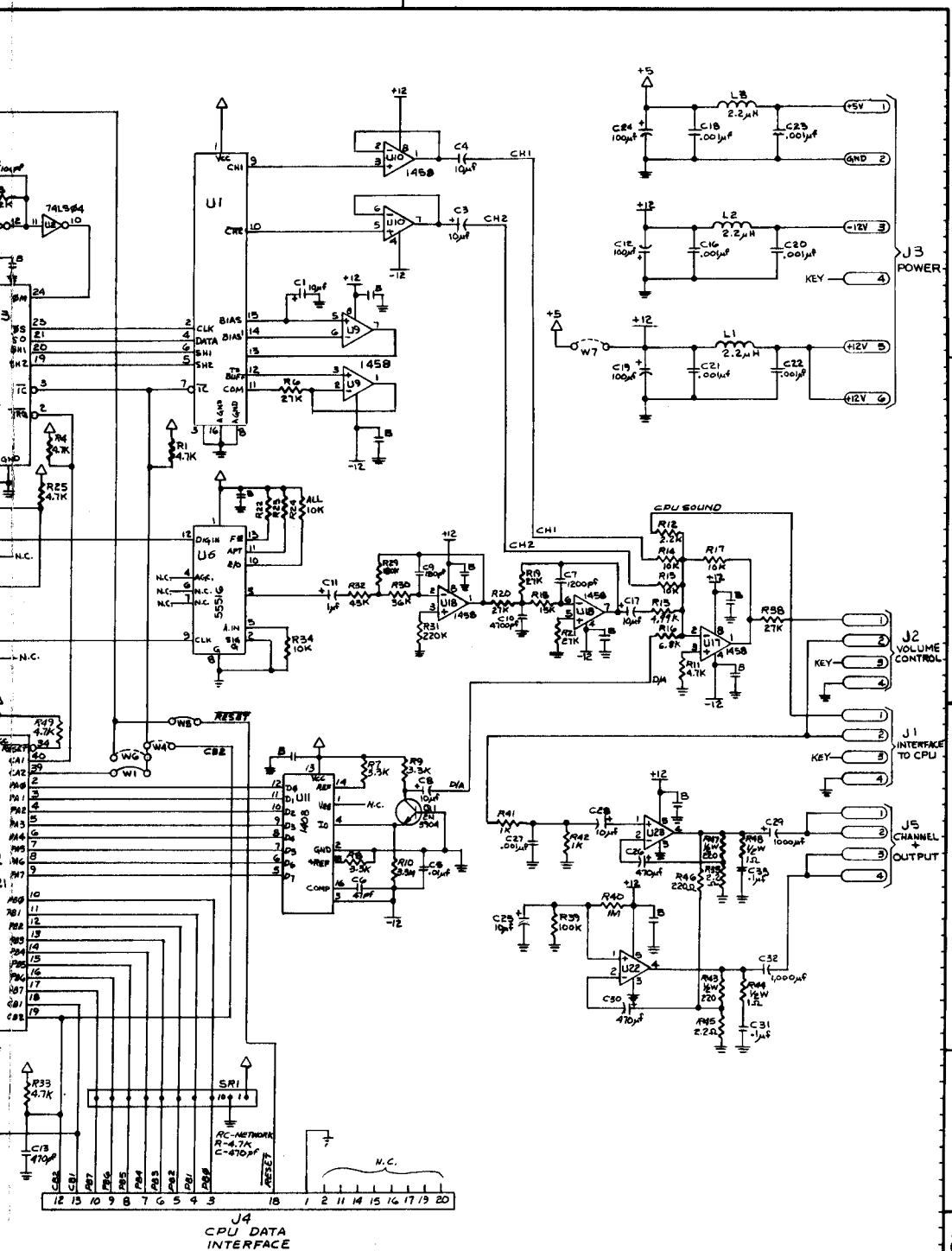

D
C
B
A

| ITEM | PART NUMBER | DESCRIPTION | QTY | ITEM | PART NUMBER | DESCRIPTION | QTY |
|--|-------------|--|-----|--|-------------|--|-----|
| PROJ ENGR C. BLEICH | | DO NOT SCALE WORK TO DIMENSIONS SHOWN | | REMOVE BURRS-BREAK SHARP CORNERS & EDGES | | TOLERANCES UNLESS OTHERWISE SPECIFIED | |
| OWN BY ROSS | | DATE 1/22/87 | | DECIMAL XXX | | ANGULAR 1/2° | |
| CHECKED BY C. BLEICH | | DATE 1/22/87 | | FRACTIONAL 1/64 | | SCALE N/S | |
| APPROVAL D. W. P. A. | | DATE 1/14 | | FIRST PROJECT NO. 554 | | SHT. 1 OF 1 | |
| FIRST USAGE D-11579 | | QTY 1 | | MATERIAL -- | | PART NO. 16-8999 | |
| WILLIAMS ELECTRONICS, INC. 3401 N. CALIFORNIA AVE. CHICAGO IL 60618 | | | | AUDIO SYSTEM SCHEMATIC | | | |

16-8999

Audio Board (D-11581) Schematic

| REV | DESCRIPTION OF CHANGE | ECN NO. | DATE |
|-----|-----------------------|---------|----------|
| | N. P. R. | | 10/24/52 |

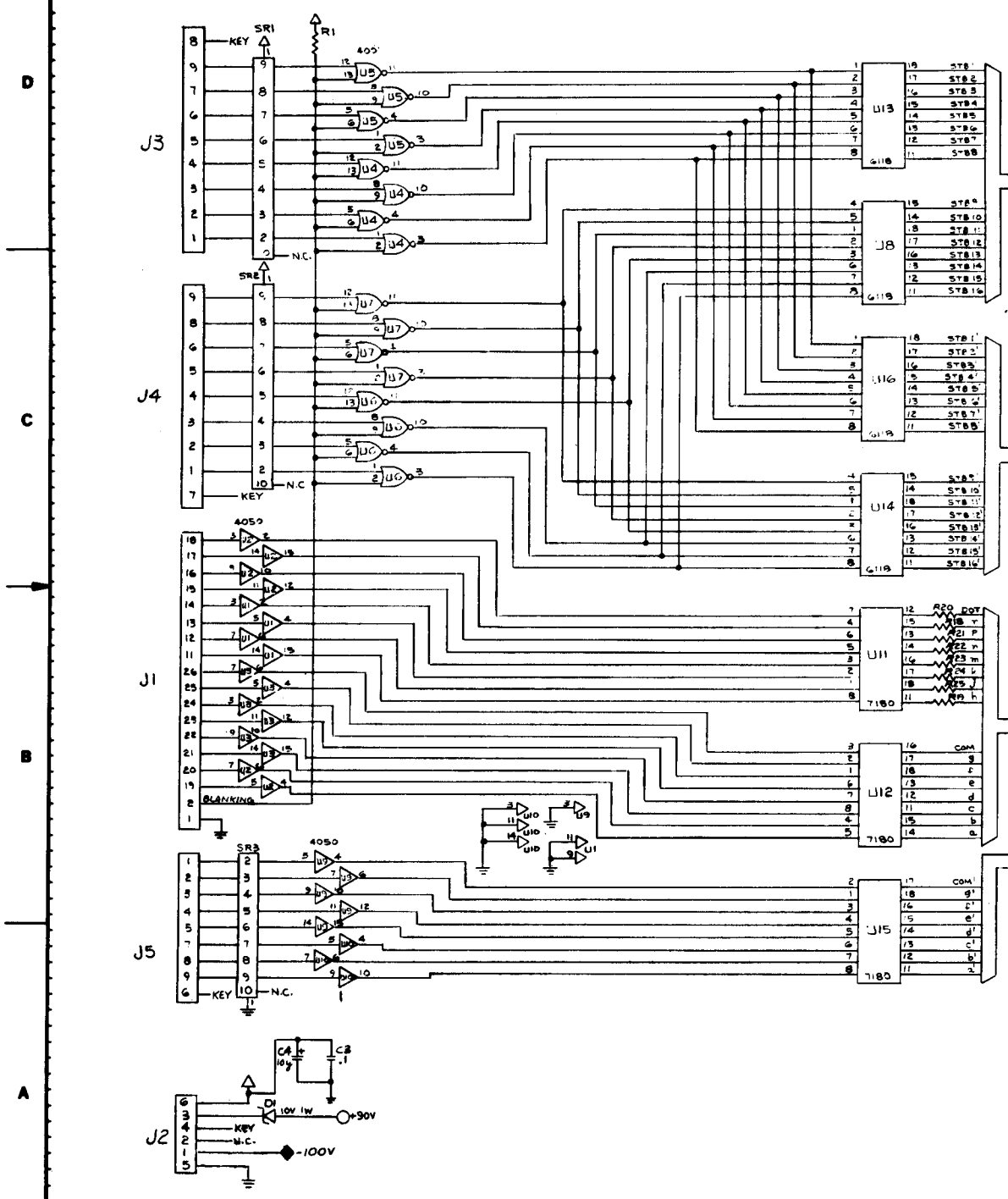

4

3

4

3

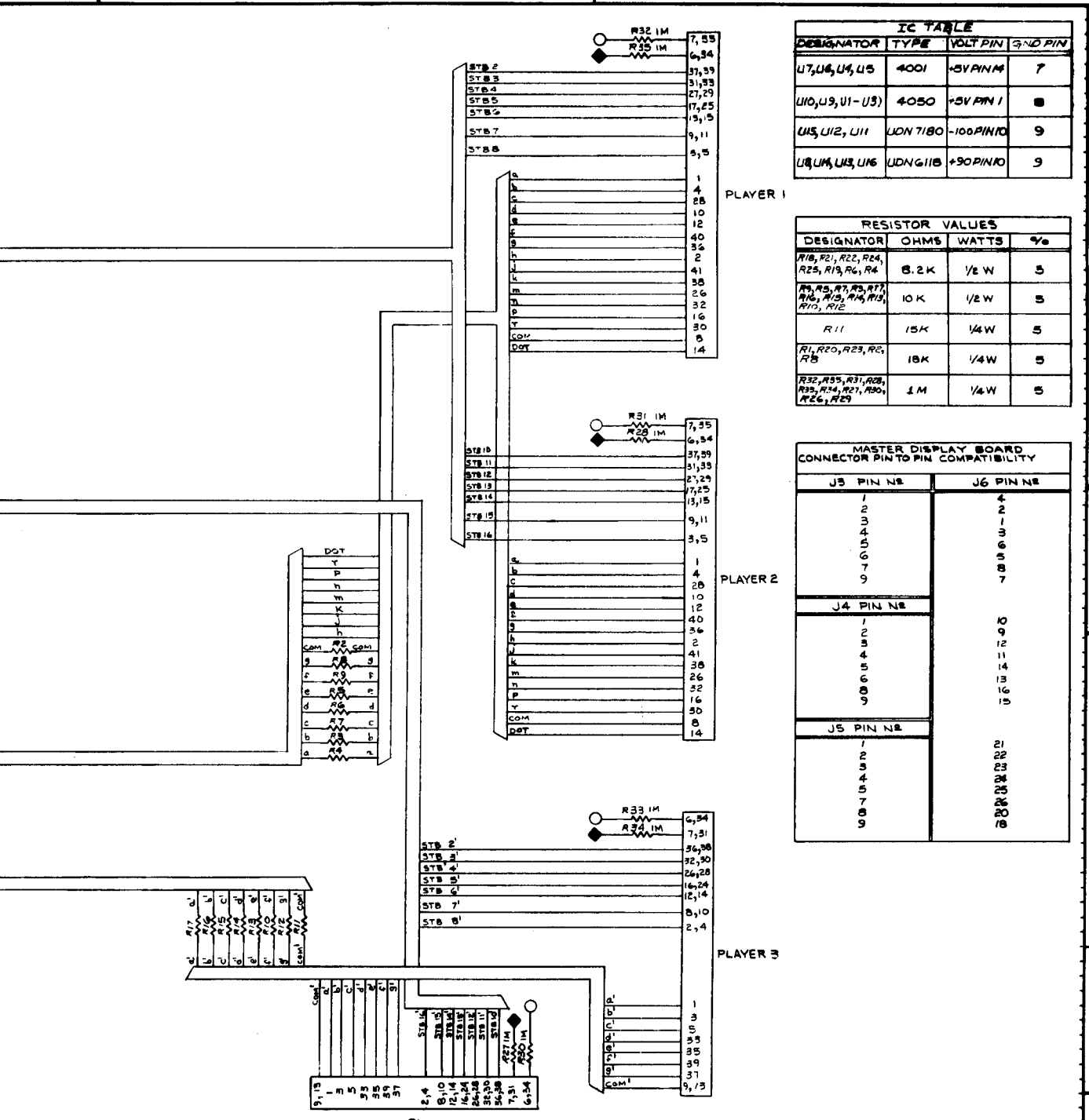

| IC TABLE | | | |
|----------------|---------|--------------|---------|
| DESIGNATOR | TYPE | VOLT PIN | 3RD PIN |
| U7, U8, U4, U5 | 4001 | +5V PIN 4 | 7 |
| U10, U3, U1-U3 | 4050 | +5V PIN 1 | 8 |
| U15, U12, U11 | UDN7180 | -100P PIN 10 | 9 |
| U13, U14, U16 | UDN7118 | +90P PIN 10 | 9 |

| RESISTOR VALUES | | | |
|---|------|-------|---|
| DESIGNATOR | OHMS | WATTS | % |
| R18, R21, R22, R24, R25, R19, R6, R4 | 8.2K | 1/8 W | 5 |
| R9, R5, R7, R3, R71, R16, R13, R14, R13, R10, R12 | 10K | 1/8 W | 5 |
| R11 | 15K | 1/4 W | 5 |
| R1, R20, R23, R2, R5 | 18K | 1/4 W | 5 |
| R22, R35, R31, R28, R25, R14, R21, R30, R26, R29 | 1M | 1/4 W | 5 |

| MASTER DISPLAY BOARD CONNECTOR PIN TO PIN COMPATIBILITY | | | |
|---|----|-----------|----|
| J3 PIN N° | | J6 PIN N° | |
| 1 | 4 | 1 | 2 |
| 2 | 2 | 2 | 1 |
| 3 | 1 | 3 | 6 |
| 4 | 3 | 4 | 5 |
| 5 | 6 | 5 | 8 |
| 6 | 5 | 6 | 7 |
| 7 | 7 | | |
| 8 | 8 | | |
| 9 | 9 | | |
| J4 PIN N° | | J5 PIN N° | |
| 1 | 10 | 1 | 21 |
| 2 | 9 | 2 | 22 |
| 3 | 12 | 3 | 23 |
| 4 | 11 | 4 | 24 |
| 5 | 14 | 5 | 25 |
| 6 | 13 | 6 | 26 |
| 7 | 16 | 7 | 20 |
| 8 | 15 | 8 | 18 |
| 9 | | 9 | |

| | | | | | | | | | | | |
|--|-------------|-------------|-----|---|-------------|-------------|-----|---|--|--|--|
| ITEM | PART NUMBER | DESCRIPTION | QTY | ITEM | PART NUMBER | DESCRIPTION | QTY | | | | |
| PROJ ENGR K. DEGER DWN BY DATE ROSS 1/21/87 CHECKED BY DATE R. DEGER 3/11/87 APPROVAL DATE D. W. 3/11/87 | | | | DO NOT SCALE WORK TO DIMENSIONS SHOWN REMOVE BURRS - BREAK SHARP EDGES TOLERANCES UNLESS OTHERWISE SPECIFIED FRACTIONAL ±1/64 ANGULAR ±1° DECIMAL ±.005 FILLETS .020 MAX MATERIAL | | | | WILLIAMS ELECTRONICS, INC. 3401 N. CALIFORNIA AVE CHICAGO ILL. 60618 NAME 1 SCHEMATIC, M/DISPLAY SCALE N/S SHT. OF PART NO. 16-9000 REV. | | | |
| FIRST PROJECT NO. 354 FIRST USAGE D-11609 QTY 1 | | | | | | | | | | | |

Alphanumeric Display Unit Board (D-11610) Schematic

CPU BOARD SYSTEM 11B D-11883

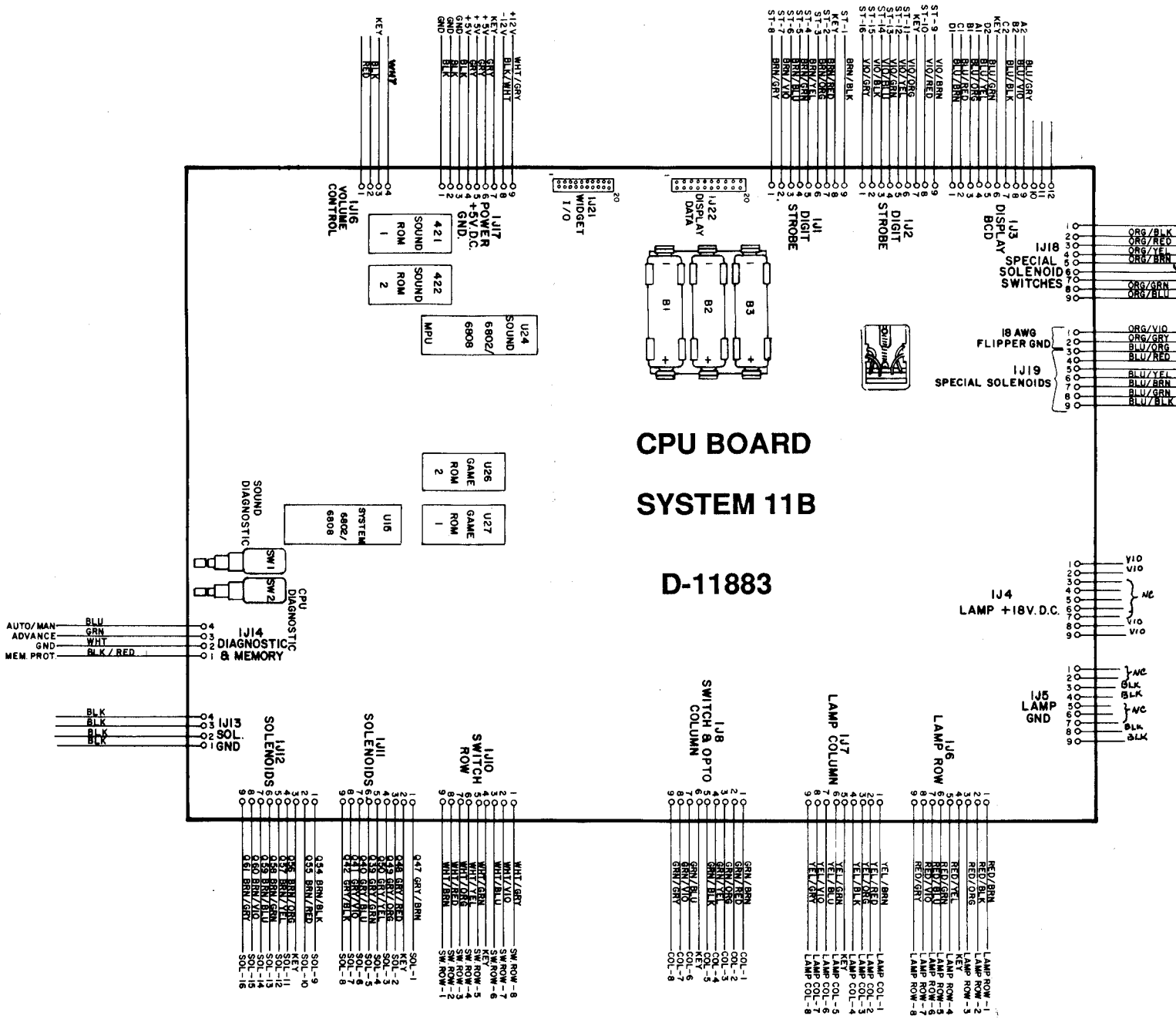

- KEY
- SP SOL - 3SW
- SP SOL - 2SW
- SP SOL - 4SW
- SP SOL - 1SW
- N.C.
- SP SOL - 5SW
- SP SOL - 6SW
- 0.75 SP SOL - 3
- 0.75 SP SOL - 2
- 0.69 KEY
- 0.75 SP SOL - 4
- 0.75 SP SOL - 1
- 0.77 SP SOL - 5
- 0.77 SP SOL - 6

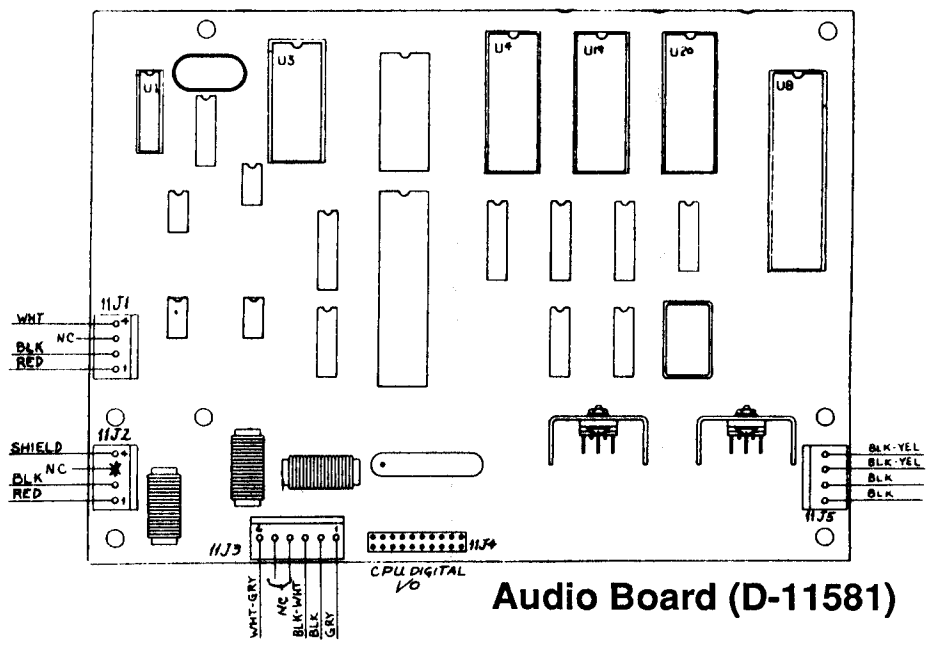
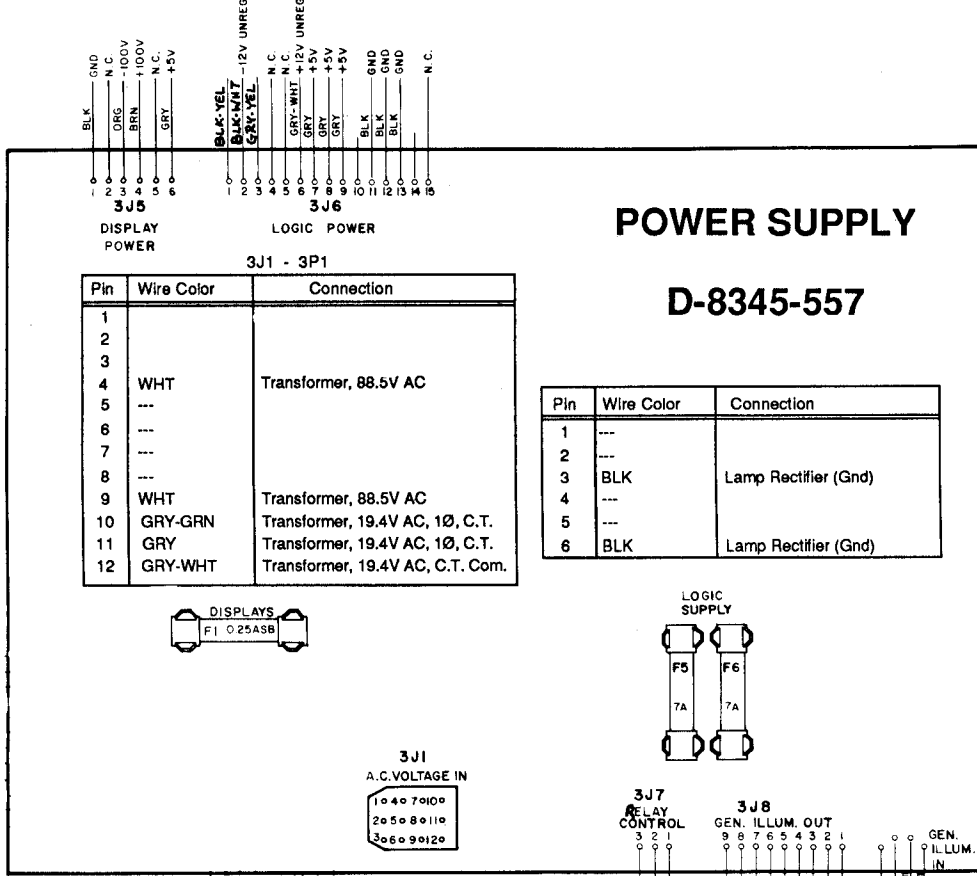

Interboards Signals Diagrams

| REV | DESCRIPTION OF CHANGE | ECN NO | DATE |
|-----|---|--------|----------|
| | NPR | 1793 | 11-9-87 |
| A | SEE COVER SHEET | 1823 | 12-3-87 |
| B | SEE COVER SHEET | 1823 | 12-30-87 |
| C | AT D4 SRB-1 WAS SRB-3 AT B4 SRB-5 WAS SRB-6 AND SR2-6 WAS SR2-5 | 1837B | 12-17-87 |

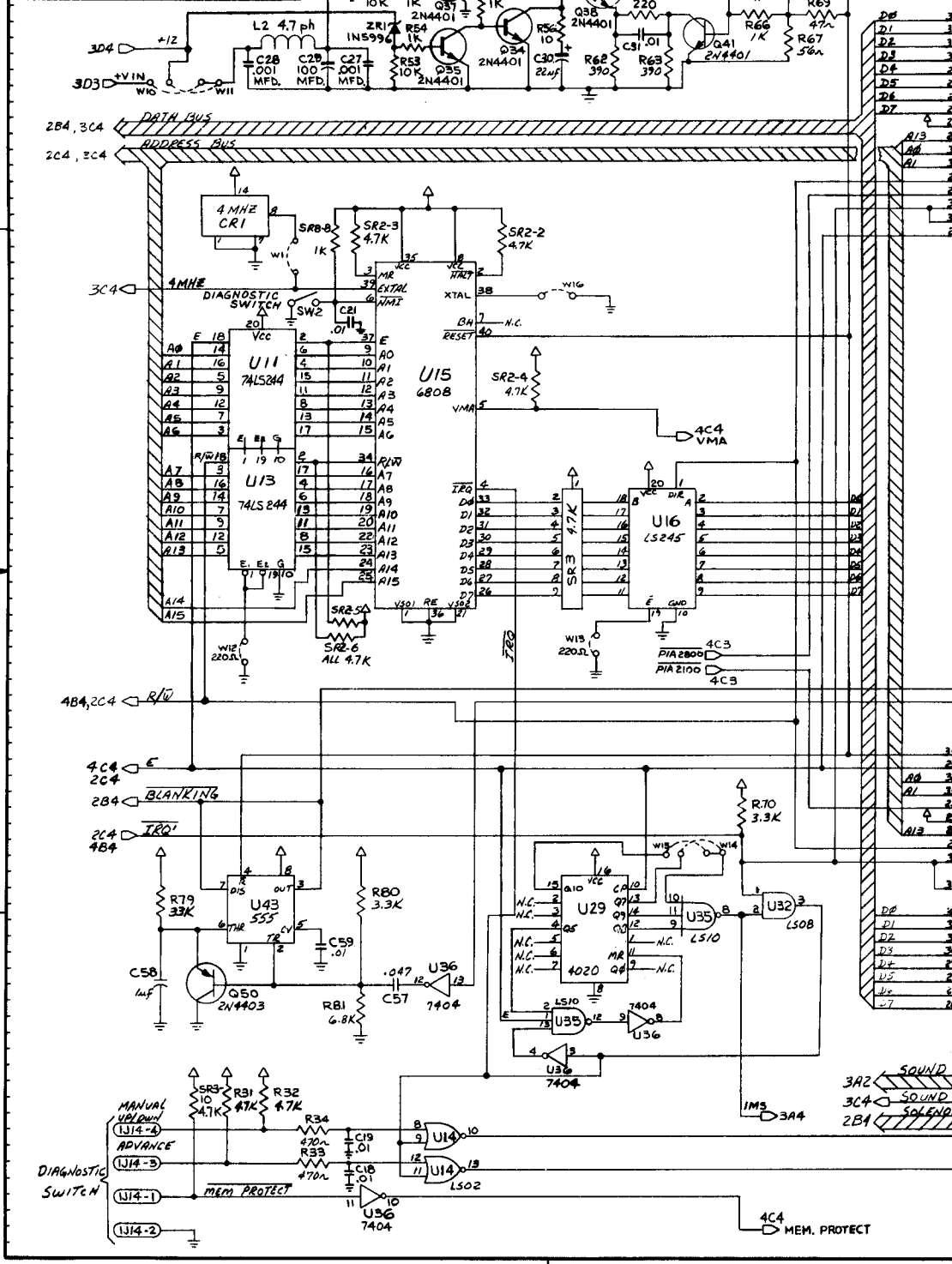

D

C

B

A

4

3

4

3

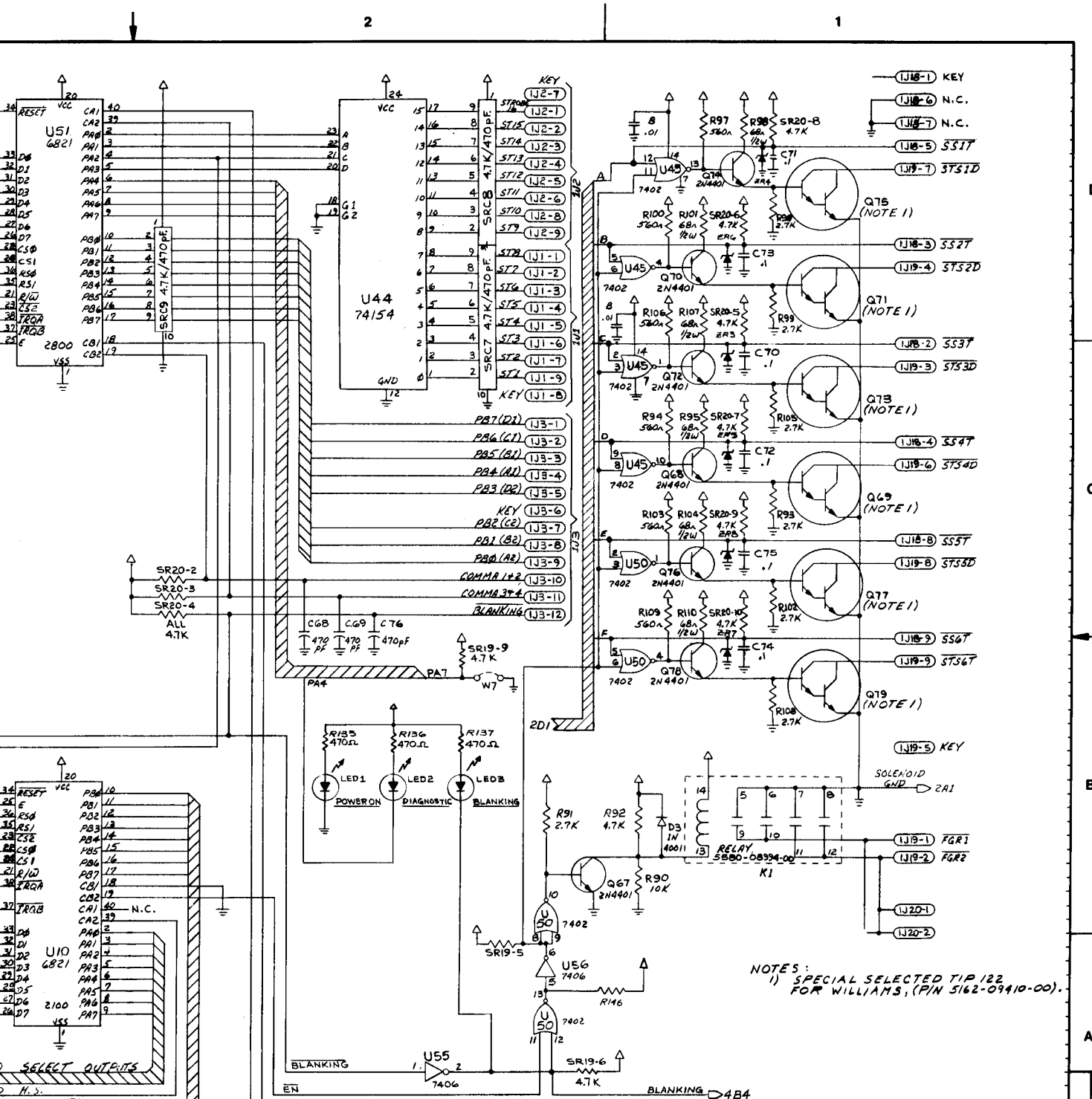

| ITEM | PART NUMBER | DESCRIPTION | QTY | ITEM | PART NUMBER | DESCRIPTION | QTY |
|------------|-------------|------------------|---------|----------------------------------|--|-------------|-----|
| PROJ ENGR | C. BLEICH | DO NOT SCALE | | REMOVE BURRS - BREAK SHARP EDGES | WILLIAMS ELECTRONICS, INC. | | |
| DOWN BY | ROSS | DATE | 8-20-81 | TOLERANCES | 3401 N. CALIFORNIA AVE CHICAGO ILL 60618 | | |
| CHECKED BY | DATE | FIRST PROJECT NO | 557 | FRACTIONAL | UNLESS OTHERWISE SPECIFIED | | |
| APPROVAL | DATE | FIRST USAGE | D-11882 | DECIMAL | .1/64 ANGULAR .020 MAX | | |
| | | | | MATERIAL | NAME CPU SYS 11B SCHEMATIC | | |
| | | | | | SCALE | SHT | LOF |
| | | | | | PART NO | 16-9019 | |
| | | | | | REV | C | |

System 11B CPU Schematic (16-9019, Sheet 1 of 4)

| REV | DESCRIPTION OF CHANGE | ECONO. DATE |
|-----|-----------------------------------|----------------|
| | NPR | 7/19/81 2-7-87 |
| A | SEE COVER SHEET | 10-23-87 |
| B | SEE COVER SHEET | 10-23-87 |
| | AT A4 C77 WAS C78 AND C78 WAS C77 | 12-17-87 |

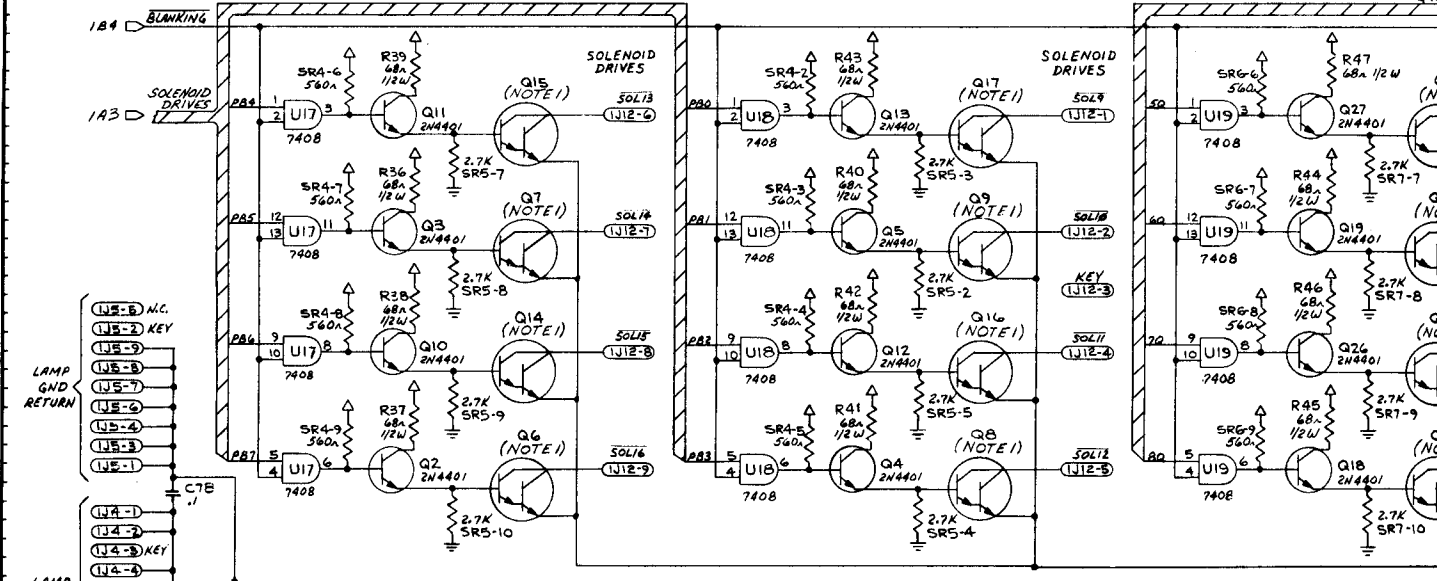
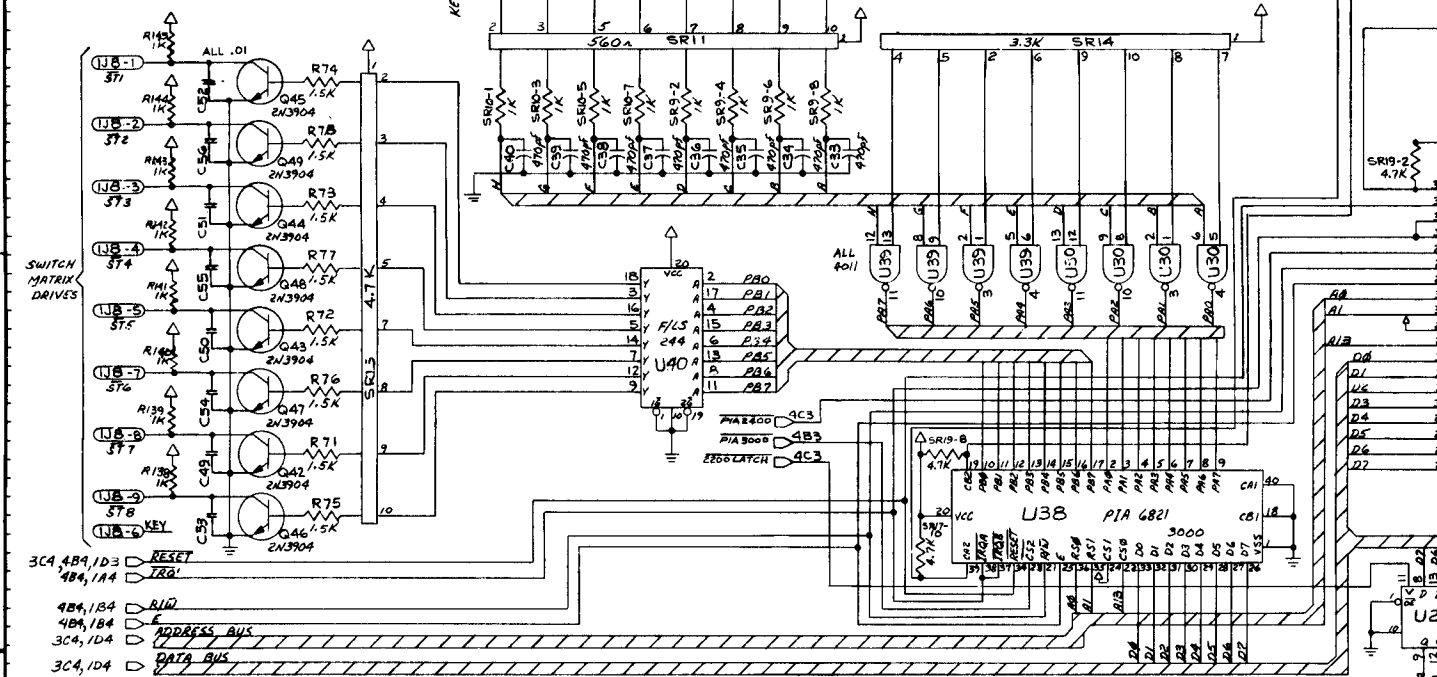

NOTES:
 1) SPECIAL SELECTED TIP 122 FOR WILLIAMS, (P/N 5162-09410-00).

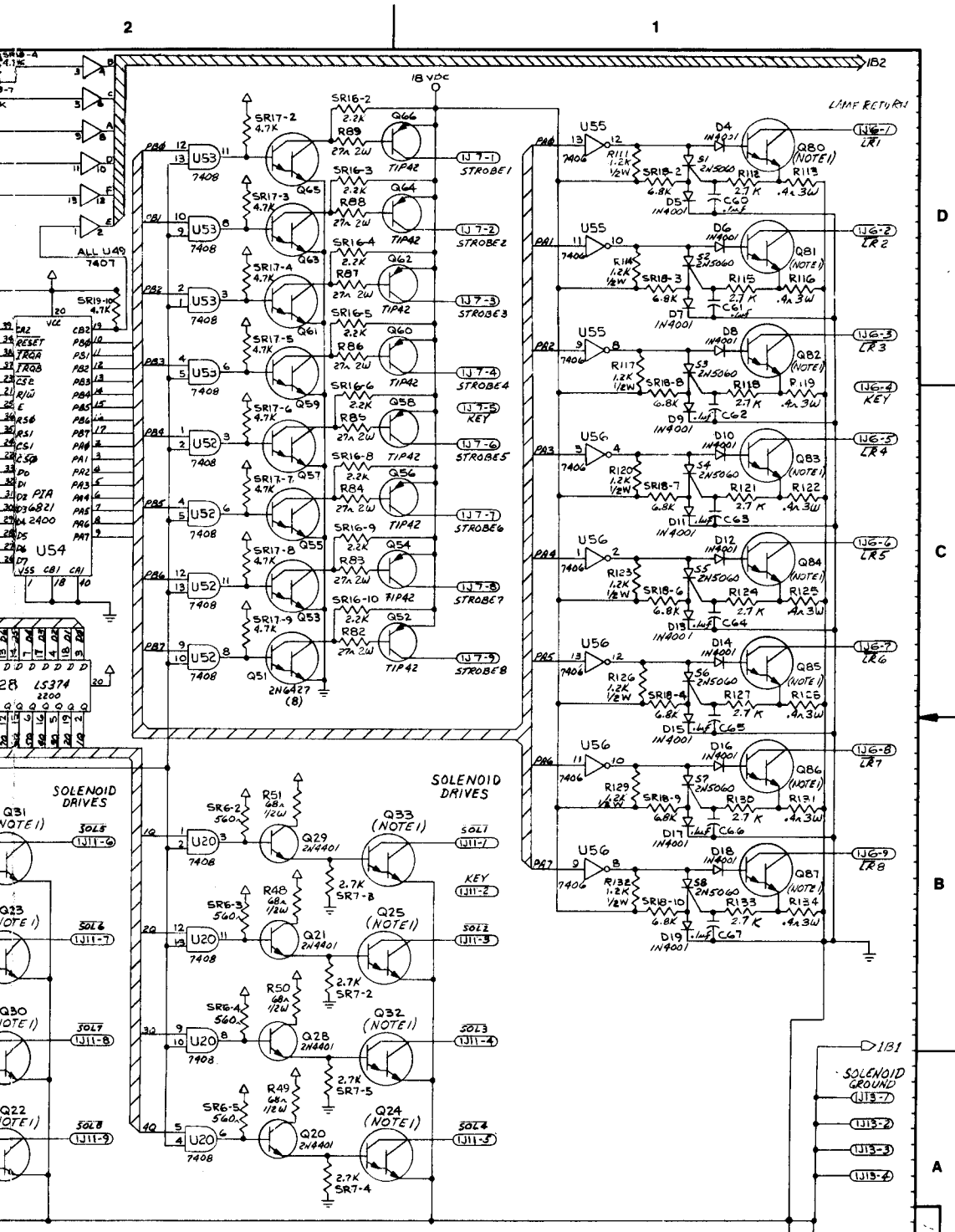

| ITEM | PART NUMBER | DESCRIPTION | QTY | ITEM | PART NUMBER | DESCRIPTION | QTY |
|-------------------------------------|-------------|--|-----|---|-------------|-----------------------------------|-----|
| PROJ. ENGR C. BLEICH | | DO NOT SCALE WORK TO DIMENSIONS SHOWN | | REMOVE BURRS - BREAK SHARP EDGES | | WILLIAMS ELECTRONICS, INC. | |
| DWN BY DATE RCS 8-20-87 | | TOLERANCES UNLESS OTHERWISE SPECIFIED | | 3401 N. CALIFORNIA AVE. CHICAGO IL 60618 | | 6106-57 | |
| CHECKED BY DATE C. BLEICH 9/1/87 | | FRACTIONAL _____ 1/64 ANGULAR _____ 31° | | NAME CPU SYS 11B SCHEMATIC | | SCALE 7 | |
| APPROVAL DATE C. BLEICH 7/7/87 | | DECIMAL _____ .005 FILLETS _____ .020 MAX | | PART NO 16-9019 | | REV C | |
| FIRST PROJECT NO. 557 | | MATERIAL | | SHT 2 OF 4 | | | |
| FIRST USAGE 6-11-82 | | | | | | | |

System 11B CPU Schematic (16-9019, Sheet 2 of 4)

| REV | DESCRIPTION OF CHANGE | EDN NO. DATE |
|-----|--|------------------|
| | N. P. R. | 7/1781-7-27 |
| A | SEE COVER SHEET | 78-23-27 |
| B | SEE COVER SHEET | 78-23-27 |
| C | AT C1 SRB-5 WAS SRB-1 DELETE SOUND SECTION @ LOCATION A3 | 1837 12-17-87 |

D
C
B
A

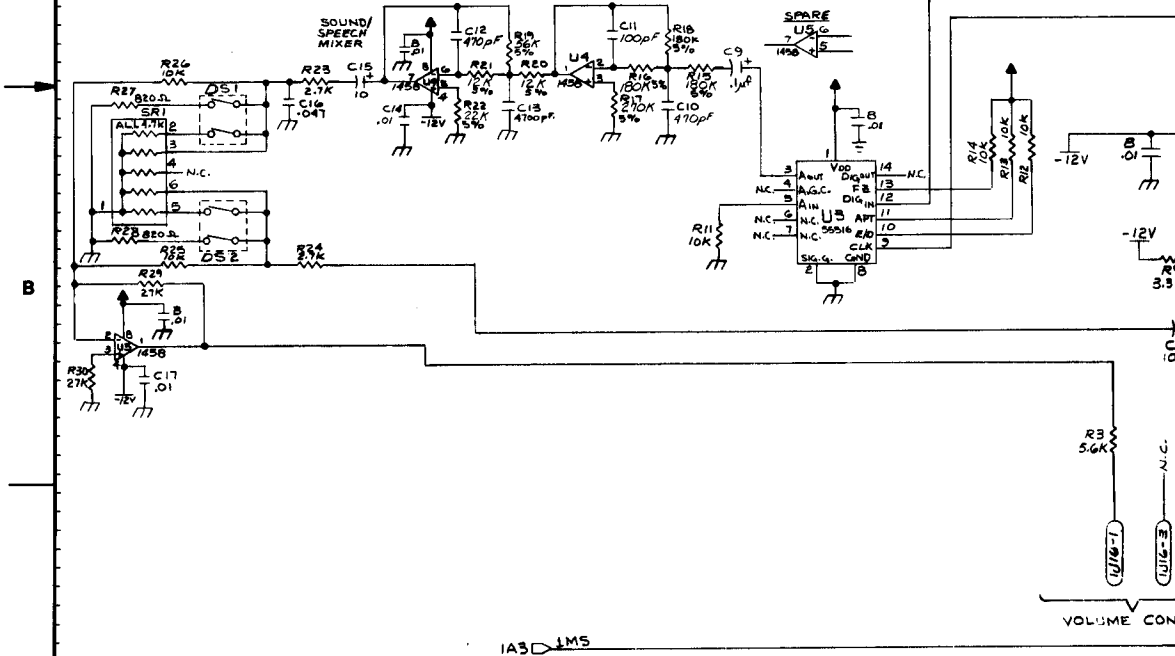
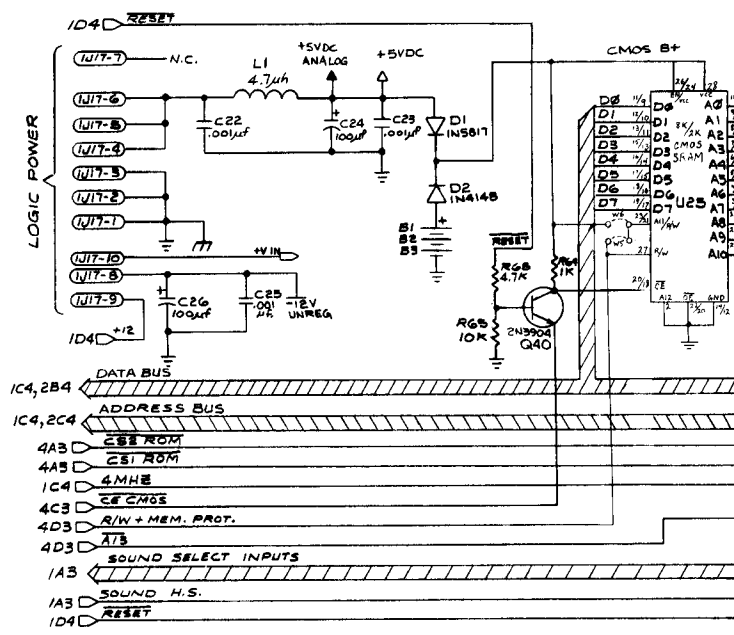

1A3 D 1MS

VOLUME CONT

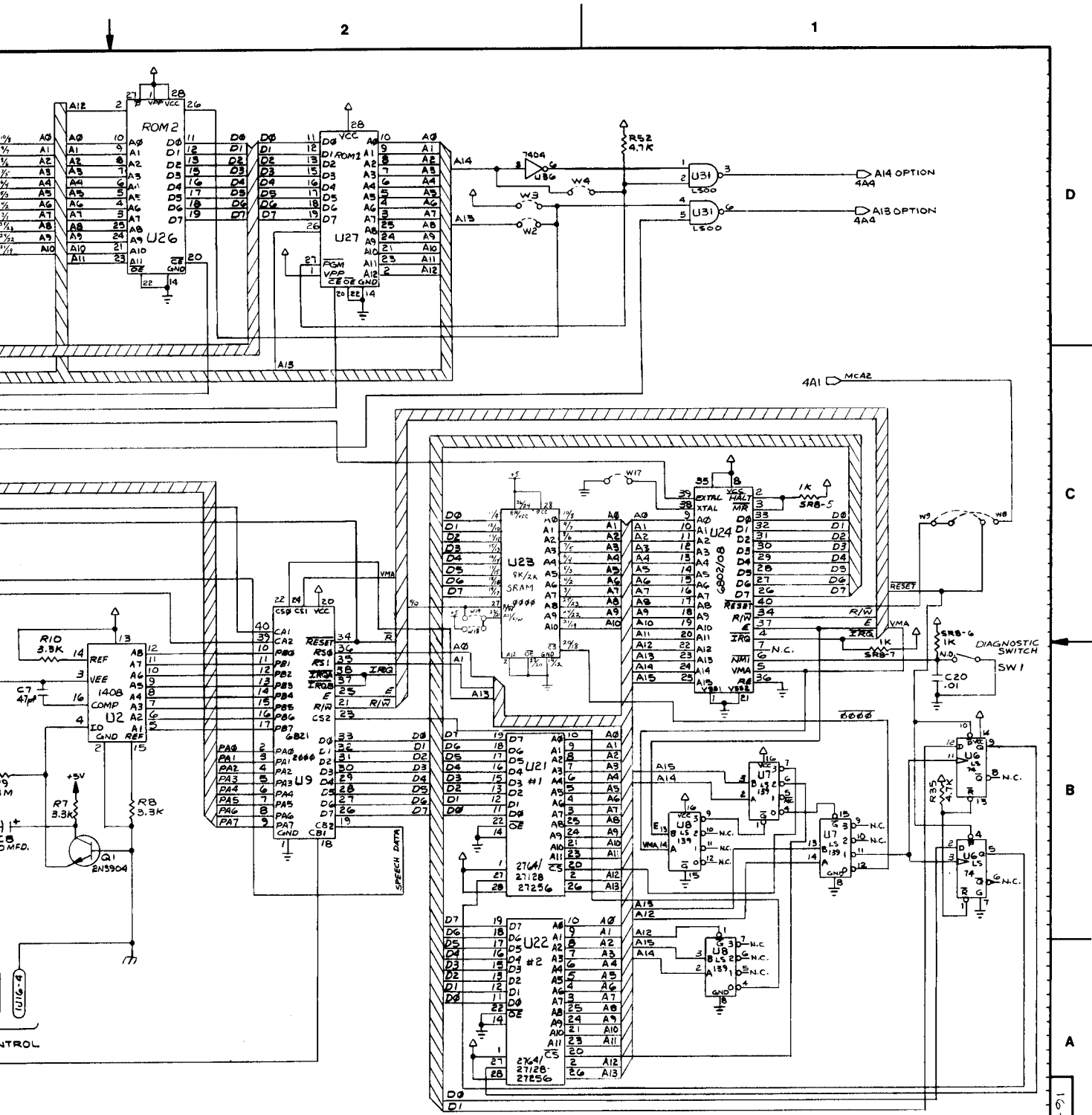

| ITEM | PART NUMBER | DESCRIPTION | QTY | ITEM | PART NUMBER | DESCRIPTION | QTY |
|--|-------------|--|-----|--|-------------|-----------------|-----|
| PROJ. ENGR C. BLEICH | | DO NOT SCALE WORK TO DIMENSIONS SHOWN | | REMOVE BURRS - BREAK SHARP EDGES | | | |
| OWN BY DATE ROSS 8-20-87 | | FIRST PROJECT NO 557 | | TOLERANCES UNLESS OTHERWISE SPECIFIED | | | |
| CHECKED BY DATE C. BLEICH 1/18/87 | | FIRST USAGE D-11882 | | FRACTIONAL _____ ±1/64 ANGULAR _____ ±1° DECIMAL _____ ±.005 FILLETS _____ .020 MAX | | | |
| APPROVAL DATE C. BLEICH 1/18/87 | | QTY — | | MATERIAL — | | | |
| WILLIAMS ELECTRONICS, INC. 3401 N. CALIFORNIA AVE. CHICAGO IL 60618 | | | | NAME CPU SYS 11B SCHEMATIC | | | |
| SCALE X | | SHT 3 OF 4 | | PART NO 16-9019 | | REV C | |

System 11B CPU Schematic (16-9019, Sheet 3 of 4)

| REV | DESCRIPTION OF CHANGE | ECN NO DATE |
|-----|-----------------------|----------------|
| | N. P. R. | 178 7-87 |
| A | SEE COVER SHEET | 182 3-87 |
| B | SEE COVER SHEET | 182 3-87 |
| C | SEE SHEET 1-3 | 183 12-87 |

D
C
B

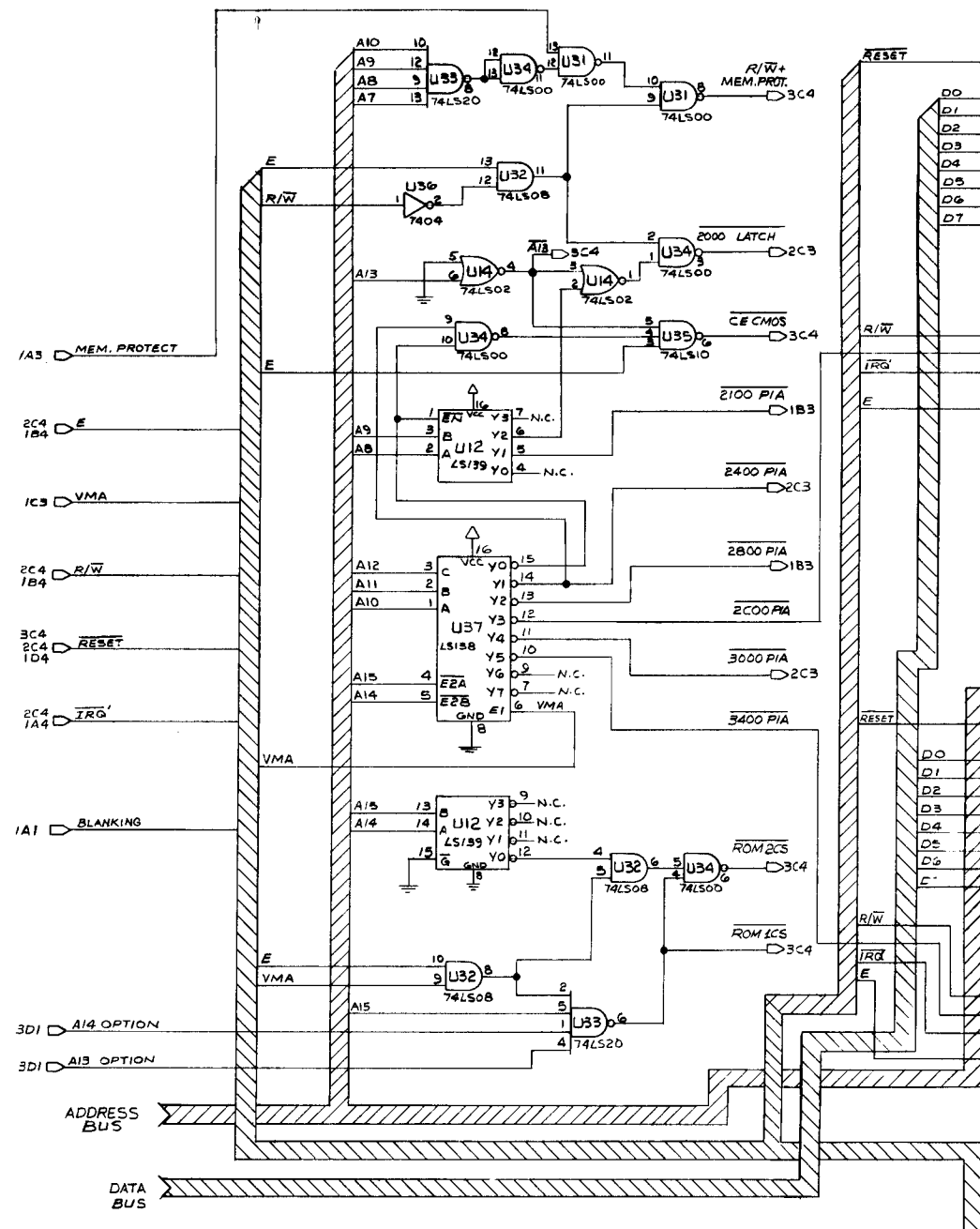

4

3

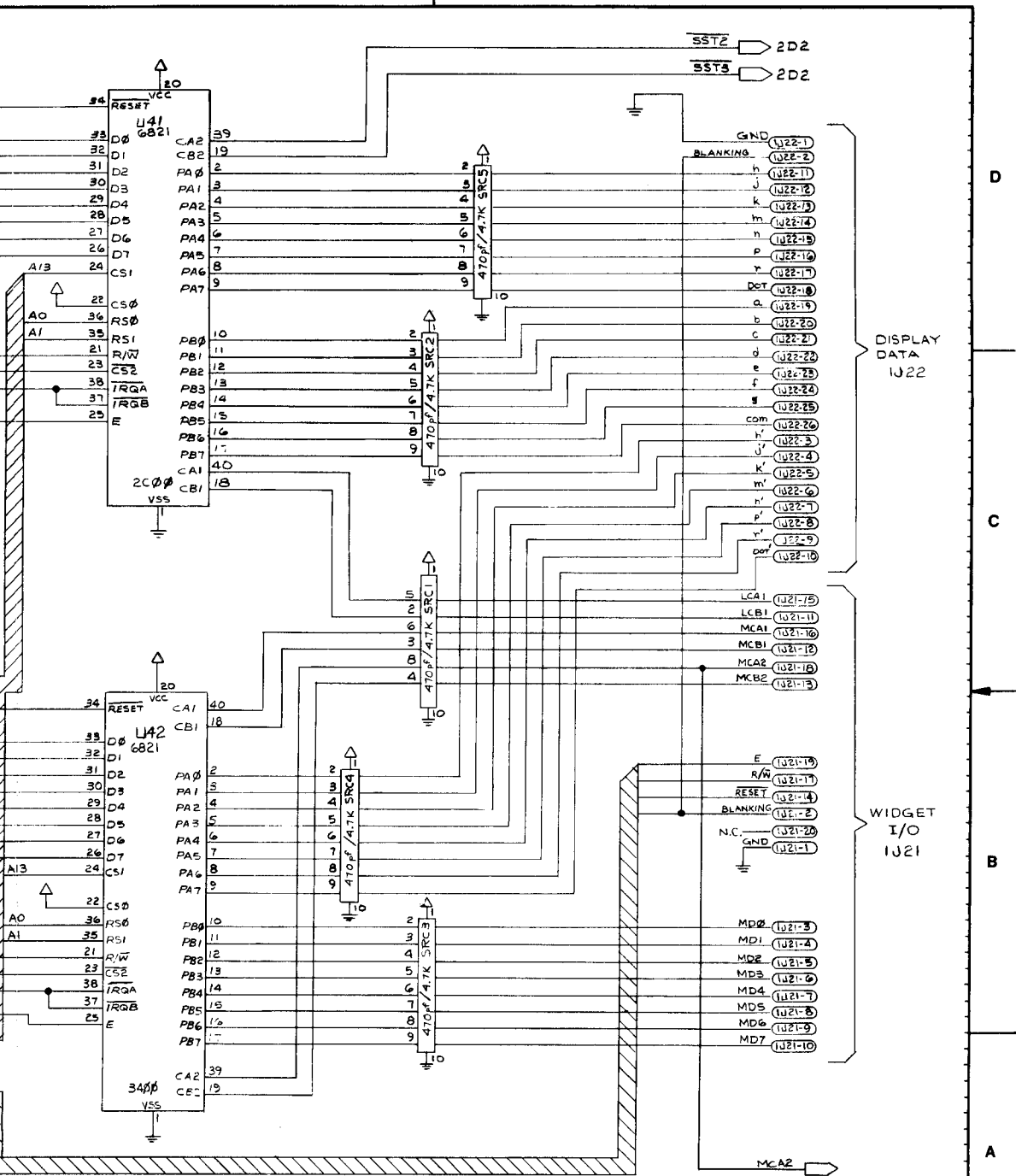

| ITEM | PART NUMBER | DESCRIPTION | QTY | ITEM | PART NUMBER | DESCRIPTION | QTY |
|-----------------------------------|-------------|--|-----|---|-------------|-----------------------------------|-----|
| PROJ ENGR C. BLEICH | | DO NOT SCALE WORK TO DIMENSIONS SHOWN | | REMOVE BURRS - BREAK SHARP EDGES | | WILLIAMS ELECTRONICS, INC. | |
| DOWN BY DATE ROSS 8-20-87 | | TOLERANCES UNLESS OTHERWISE SPECIFIED | | 3401 N. CALIFORNIA AVE. | | CHICAGO IL. 60618 | |
| CHECKED BY DATE G. Ross 9/4/87 | | FRACTIONAL ±1/64 ANGULAR ±1° | | NAME CPU SYS IIB SCHEMATIC | | | |
| APPROVAL DATE D-11882 | | DECIMAL ±.005 FILLETS .020 MAX | | SCALE N/S | | SHT. 4 OF 4 | |
| FIRST PROJECT NO. 557 | | MATERIAL 11 | | PART NO. 16-9019 | | REV C | |
| FIRST USAGE | | | | | | | |

System 11B CPU Schematic (16-9019, Sheet 4 of 4)

CYCLONE Lamp-Matrix Table

2 Two Lamps

Lamps = #44 Bulb, p/n 24-6549
555 Bulb, p/n 24-8768

| COLUMN ROW | 1 Q66 YEL-BRN 1J7-1 | 2 Q64 YEL-RED 1J7-2 | 3 Q62 YEL-ORN 1J7-3 | 4 Q60 YEL-BLK 1J7-4 | 5 Q58 YEL-GRN 1J7-6 | 6 Q56 YEL-BLU 1J7-7 | 7 Q54 YEL-VIO 1J7-8 | 8 Q52 YEL-GRY 1J7-9 |
|----------------------|----------------------------------|---|------------------------------|-----------------------------------|--|--|---------------------------|--------------------------------------|
| Q80 RED-BRN 1J6-1 | HOLD 1 | W/L SCORE FERRIS WHEEL 2 BONUS 9 | RIDE AGAIN 17 | EXTRA BALL Left Outlane 25 | Mystery Wheel (tdc-top dead center) 33 | Mystery Wheel (180 deg from tdc) 41 | 2X 49 | 500,000 Bonus (Backglass) 57 |
| Q81 RED-BLK 1J6-2 | BONUS 2 | ADV. " X" 10 | SPINS MYSTERY WHEEL 18 | EXTRA BALL Right Outlane 26 | Mystery Wheel (22-1/2 deg rt of tdc) 34 | Mystery Wheel (157-1/2 deg left of tdc) 42 | 7X 50 | 1,000,000 Bonus (Backglass) 58 |
| Q82 RED-ORN 1J6-3 | DOUBLE 3 | Balloon 25K (Ducks) 11 | Ducks (top) 19 | COMET 20K 27 | Mystery Wheel (45 deg rt of tdc) 35 | Mystery Wheel (135 deg left of tdc) 43 | 6X 51 | 1,500,000 Bonus (Backglass) 59 |
| Q83 RED-YEL 1J6-5 | SCORES 4 | Balloon 50K (Ducks) 12 | Ducks (mid) 20 | COMET 40K 28 | Mystery Wheel (67-1/2 deg rt of tdc) 36 | Mystery Wheel (112-1/2 deg left of tdc) 44 | 5X 52 | 2,000,000 Bonus (Backglass) 60 |
| Q84 RED-GRN 1J6-6 | CYCLONE 50K 5 | Balloon LITES EX. BALL (Ducks) 13 | Ducks (bottom) 21 | COMET 60K 29 | Mystery Wheel (90 deg rt of tdc) 37 | Mystery Wheel (90 deg left of tdc) 45 | 4X 53 | 2,500,000 Bonus (Backglass) 61 |
| Q85 RED-BLU 1J6-7 | CYCLONE 100K 6 | 1 (Gate Lane) 14 | Ball Toss (top) 22 | COMET 80K 30 | Mystery Wheel (112-1/2 deg rt of tdc) 38 | Mystery Wheel (67-1/2 deg left of tdc) 46 | 3X 54 | 3,000,000 Bonus (Backglass) 62 |
| Q86 RED-VIO 1J6-8 | CYCLONE Gate Bonus 7 | 2 (Gate Lane) 15 | Ball Toss (mid) 23 | COMET 100K 31 | Mystery Wheel (135 deg rt of tdc) 39 | Mystery Wheel (45 deg left of tdc) 47 | MYSTERY (Backglass) 55 | 3,500,000 Bonus (Backglass) 63 |
| Q87 RED-GRY 1J6-9 | RIDE THE COMET (on ramp) 8 | 3 (Gate Lane) 16 | Ball Toss (bottom) 24 | COMET 1 Million 32 | Mystery Wheel (157-1/2 deg rt of tdc) 40 | Mystery Wheel (22-1/2 deg left of tdc) 48 | WHEEL (Backglass) 56 | 4,000,000 Bonus (Backglass) 64 |

CYCLONE Switch-Matrix Table

| COLUMN ROW | 1 Q45 GRN-BRN 1J8-1 | 2 Q49 GRN-RED 1J8-2 | 3 Q44 GRN-ORN 1J8-3 | 4 Q48 GRN-YEL 1J8-4 | 5 Q43 GRN-BLK 1J8-5 | 6 Q47 GRN-BLU 1J8-7 | 7 Q42 GRN-VIO 1J8-8 | 8 Q46 GRN-GRY 1J8-9 |
|---------------------|---------------------------|----------------------------|-----------------------------|-----------------------------|---------------------------|--|------------------------------|---------------------------------|
| 1 WHT-BRN 1J10-9 | Plumb Bob Tilt 1 | Playfield Tilt 9 | Ferris Wheel Entrance 17 | Ball Shooter Lane 25 | Not Used 33 | Mystery Wheel Opto "Home" (Insert bd) 41 | Not Used 49 | Left Flipper Lane Change 57 |
| 2 WHT-RED 1J10-8 | Not Used 2 | Outhole 10 | Drop Target (center) 18 | Shuttle 10K (kickbig) 26 | Score CYCLONE 34 | Not Used 42 | Not Used 50 | Right Flipper Lane Change 58 |
| 3 WHT-ORN 1J10-7 | Credit Button 3 | Score Spook House 11 | Ducks (top) 19 | Shuttle 25K (bottom) 27 | 10 pt (R. Bottom) 35 | Not Used 43 | Not Used 51 | Spot Ball Toss 59 |
| 4 WHT-YEL 1J10-6 | Right Coin Chute 4 | Not Used 12 | Ducks (middle) 20 | Shuttle 100K 28 | 10 pt (R. Middle) 36 | Not Used 44 | Not Used 52 | Left Jet Bumper 60 |
| 5 WHT-GRN 1J10-5 | Center Coin Chute 5 | Boomerang Kickbig 13 | Ducks (bottom) 21 | Shuttle 25K 29 | 10 pt (R. Top) 37 | Not Used 45 | Left Outlane Ex. Ball 53 | Right Jet Bumper 61 |
| 6 WHT-BLU 1J10-3 | Left Coin Chute 6 | 1 Lane 14 | Ball Toss (top) 22 | Shuttle 5K (top) 30 | Not Used 38 | Not Used 46 | Right Outlane Ex. Ball 54 | Bottom Jet Bumper 62 |
| 7 WHT-VIO 1J10-2 | Slam Tilt 7 | 2 Lane 15 | Ball Toss (middle) 23 | Enter COMET Ramp 31 | Not Used 39 | Not Used 47 | Left Return Lane 55 | Left Kicker 63 |
| 8 WHT-GRY 1J10-1 | High-Score Reset 8 | 3 Lane 16 | Ball Toss (bottom) 24 | Score COMET Ramp 32 | Not Used 40 | Not Used 48 | Right Return Lane 56 | Right Kicker 64 |

WARNINGS & NOTICES

WARNING

FOR SAFETY AND RELIABILITY, *WILLIAMS ELECTRONICS GAMES* does not recommend or authorize any substitute parts or modifications of *WILLIAMS'* equipment. Use of Non-*WILLIAMS'* parts, or modifications of game circuitry, may adversely affect game play, or may cause injuries.

SUBSTITUTE PART OR EQUIPMENT MODIFICATIONS may void FCC Type Acceptance.

BECAUSE THIS GAME IS PROTECTED by Federal copyright, trademark, and patent laws, unauthorized game conversions may be illegal under Federal law.

THIS 'CONVERSION' PRINCIPLE ALSO APPLIES to unauthorized facsimiles of *WILLIAMS'* equipment, logos, designs, publications, assemblies, and games (or game features not deemed to be in the public domain), whether manufactured with *WILLIAMS'* components or not.

WARNING

This equipment generates, uses, and can radiate radio frequency energy, and if not installed and used in accordance with the instructions manual, may cause interference to radio communications. It has been tested and found to comply with the limits for a Class A computing device pursuant to Subpart J of Part 15 of FCC Rules, which are designed to provide reasonable protection against such interference when operated in a commercial environment. Operation of this equipment in a residential area is likely to cause interference in which case the user at his own expense will be required to take whatever measures may be required to correct the interference.

WARNING

FCC STICKER. Check the back of your *CYCLONE* game to verify that an FCC-certification sticker was attached to your game at the factory.

All games that leave *WILLIAMS'* plants have been tested and found to comply with FCC Rules. Because the sticker is proof of this fact, legal repercussions to the owner and distributor of the game may result, if the sticker is missing. If you receive any *WILLIAMS'* game, manufactured after December 1982, that has no FCC sticker, call *WILLIAMS'* for advice or write us a note on your Game Registration Card. Be sure that the card bears your game's serial number.

RF Interference Notice

CABLE HARNESS PLACEMENTS and ground strap routing on this game have been designed to keep RF radiation and conduction within levels accepted by the FCC Rules.

TO MAINTAIN THESE LEVELS, reposition harnesses and reconnect ground straps to their original placements, if they become disconnected during maintenance.

Notice

CYCLONE and Lane Change are trademarks of *WILLIAMS ELECTRONICS GAMES, INC.*

FOR SERVICE...

CALL your authorized
WILLIAMS' Distributor.

Williams[®] 
ELECTRONICS GAMES, INC.

3401 N. California Avenue
Chicago, IL 60618

© - 1988 *WILLIAMS ELECTRONICS GAMES, INC.*

WARNING: Transport this game **ONLY** with hinged backbox down!