

# Physical properties of flax fibre for non-textile-use

K.-H. KROMER

*Department of Agricultural Engineering, Rheinische Friedrich-Wilhelms-University Bonn, Bonn, Germany*

**Abstract:** The industrial use of natural fibre has been continuously increasing since 1996. In the interior of cars, the percentage of fibre-reinforced multi-material parts may reach 40%. Quality management needs standards for measuring reliable physical properties. The aim of the article is to summarise the appropriate and approved methods for measuring geometrical, gravimetical, and mechanical properties of flax fibre. Test standards are also needed for fibre-reinforced plastics, an additional method is explained and compared with the existing standards. The use of these methods is demonstrated using selected test data.

**Keywords:** physical properties; flax fibre; fibre-reinforced plastic parts; measuring methods; standardization; method application

The interest in biological materials from agricultural field production is not due to the limited energy resources and climatic change but to specific properties suitable for industrial use along with the advantage that they can be recycled, also thermally. In 1998, in Germany, were issued the limits for the non-reusable portion of cars (AltautoV), in 2015 a maximum of 5% will be allowable. Consequently, natural non-food materials such as wood, starch, and fibre are increasingly used in composite materials (MIECK *et al.* 1995). The following article deals with the use of short-fibre-flax. In this case, these materials will replace the industrially manufactured fibres (i.e. glass) with well known specific and constant properties (PÜTZ 1993; BECKMANN 1998; MUSSIG & HARIS 2000). Initially, natural fibres will be used in multi-material parts of mould systems. In the case of using composite materials in cars, the weight percentage of plastic, reinforced with biological materials may be up to a total of 15%, for an equivalent fuel savings of 3 to 5 l/100 km per 100 kg. The car interior parts containing natural fibre may even reach 40%, (GASSAN 2003; KARUS *et al.* 2003; HENKEL 2007). Flax fibre may also replace hazardous materials like asbestos (i.e. brake material).

Before utilizing these materials, the selection and production of specific fibre for industry requires the knowledge of these material properties due to the variety, location of production, time dependability and influence of the production system. Technically

relevant physical properties are only as good as their definitions, the methods for gaining replicable data, and accuracy and availability of the appropriate documentation (KROMER *et al.* 2002).

## MATERIAL

The material used for the research and development of the test procedures has been flax. Flax (*Linum usitatissimum* L. and *Linum angustifolium* Huds.) is an annual crop for multipurpose use. Initially, varieties had been selected for fibre or oil use, and later for a combination of these, so called combination-flax for fibre and oil production (DAMBROTH *et al.* 1988; KROMER *et al.* 1995a; WIELAGE *et al.* 2001). In the recent breeding, short-fibre-flax was bred for multi-purpose use, including the industrial, non-textile use (i.e. in composites), the physical properties having become the selection criteria.

The plant parts are the roots, the stem, the capsular and the seeds, while relevant for the fibre production is the stem (Figure 1). The stem has a length of 600 to 1000 mm. The top branches out, developing a rispy inflorescence. The sclerenchyma cells (elementary fibre) are organised in bundles, radial around the cambium and wooden body, surrounding the lumen. The fibre bundle is covered by a bark structure, epidermis and cuticle on the outside, requiring decortication. For the textile use, those bundles must be taken apart softly to keep the

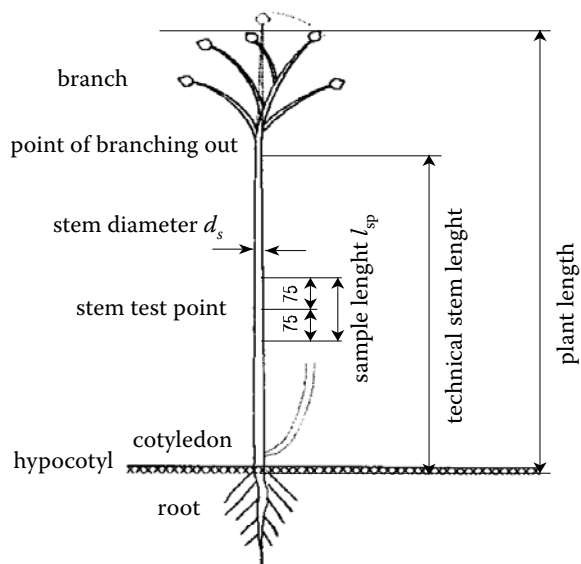

Figure 1. Schematic view of a flax plant

maximum bundle fibre length of 70 mm, while the binding between the elementary fibre should be retained. For the non-textile use, the length of 10 to 20 mm will be sufficient. The number of bundles per stem vary from 20 to 50 and the number of elementary fibre per bundle vary from 10 to 30. The numbers differ over the stem length and the fibres are parallel but off-set. For the industrial use, the non-retted stems are dominantly mechanically decorticated (KROMER *et al.* 1995b; BECKMANN 1998; SCHNEGELSBURG 1999).

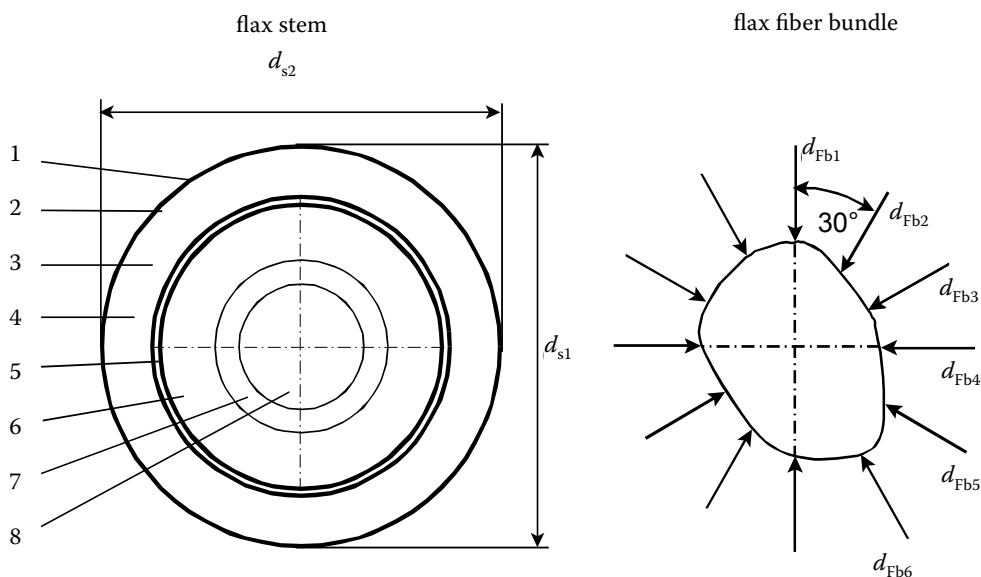

Figure 2. Structure and diameter for measuring geometric properties of stem and bundle

1 – cuticle, 2 – epidermis, 3 – bark, 4 – bundle, 5 – Cambium, 6 – wooden body, 7 – Parenchyma, 8 – marrow

## METHODS

### Geometrical properties

The stem and bundle diameters and cross areas are defined in Figure 2. Non-destructive measuring systems may be used when available. The best results were obtained using a laser micrometer (error < 0.02%), measuring the stem twice with 90° increment ( $d_{s1}$  and  $d_{s2}$ ) and the bundle 6 times with 30° increments ( $d_{Fb1}$  to  $d_{Fb6}$ ). The arithmetic average of the diameter is calculated and then used to calculate the cross-sectional area assuming it to be a circle.

The stem length, technically relevant, is defined as the distance between the cotyledon and the point of the branching out. The plant length is the distance between the cotyledon and the upper capsule. Both were calculated as the arithmetic average from the stems harvested along one meter in the field.

### Gravimetric properties

The test material was harvested manually, with a random selection of 6 stems and taking samples of 150 mm length from the middle of the technically relevant stems, Figure 1. The test samples were dried at 40°C for 36 h, then stored in a desiccator. In addition, 30 g were cut into 20 mm pieces and dried in an open sample probe glass holder at 105°C for 15 h, (DIN 50 014 1985; VDLUFA 1988; KROMER *et al.* 1999; KROMER & HEIER 2001).

Table 1. Adjustment of the Bahmer-Labor-Flachs-Brecher Flaksy®

No. of roller pairs (pieces)	1	2	3	4
Revolution frequency rpm $n_{\max}$ (1/min)	80	80	96	110
No. of teeth per roller (pieces)	9	12	11	12
Roller diameter (mm)	57.0	55.0	52.5	51.0
Tooth length of toothed wheel roller (mm)	10.0	8.0	6.5	4.5
Load $F_{Fe}$ (2 springs per roller) (N)	40	40	40	40

Table 2. Adjustment of the universal material testing machine (ZWICK 1445)

Sample	Stem	Fibre bundle		
Error – length measure (%)	measuring instrument < 0.1	traverse movement < 1		
Sample length at start $l_0$ (mm)	23.0	25.0	10.0	2.0
Clamping length $l_E$ (mm)	25.0	25.0	10.0	2.0
Total length of sample $l_p$ (mm)	150.0	100.0	100.0	80.0
Testing speed $v_p$ (mm/min)	3.0	3.0		
Lead load $F_{lead}$ (N)	5.0	0.05*		
Error – force measure (%)	< 2**	< 2**		
Calculating E-modulus	ascent in the range 40% to 60% of $F_{\max}$	ascent in the range 40% to 60% of $F_{\max}$		
Shut-off threshold	force descent to 80% of $F_{\max}$	force descent to 80% of $F_{\max}$		

\*For stretching the fibre bundle is used a 2 g weight before the clamping process

\*\*Measuring range of the load sensor: stem 0.2–10 kN, fibre bundle 1–50 N

The dry matter content is the percentage of dry matter of the probe weight.

The moisture content wet basis (mcwb) is the percentage of mass loss due to drying related to the fresh, wet sample.

$$\text{mcwb} = (m - m_T) 100/m$$

The moisture content dry basis (mcdb) is the percentage of mass loss due to drying related to the dry sample.

$$\text{mcdb} = (m - m_T) 100/m_T$$

Technically usable fibre content ( $w_{\text{tnF}}$ ) is the percentage of the mass of fibre related to the mass of

the dried sample. The mass of pollution should be < 5%. For decortication, the Bahmer-Labor-Flachs-Brecher Flaksy® (BFLB 04) is the recommended equipment (BECKMANN 1998; KOCH *et al.* 1995).

The air dried sample has to be conditioned at 30°C for 24 h to a dry matter content of 92%–95% (weight constant) (Table 1).

$$w_{\text{tnF}} = m_{4 \times 10} 100/m_E$$

Fineness  $T_l$  is according to DIN 60 905 (1970) a length related mass, calculated using the mass  $m$  and the fibre length  $l$ , the unit is Tex (1 Tex is equivalent to 1 g of 1000 m length). The calculation may be done for the stem as well as for the fibre bundle.

Table 3. Clamp specification (sample holder)

Sample	Stem	Fibre bundle
Force provided	pneumatic	pneumatic
Clamping force $F_{\text{press}}$ (N)	375.0	50.0
Clamping area ( $l \times b$ ) (mm)	50 × 60	20 × 20
Clamping material	basic holder (metal clamps) covered with plastic Vulkollan 80 (1 mm thick)	as for stems plus grinding paper (grind 1 200)

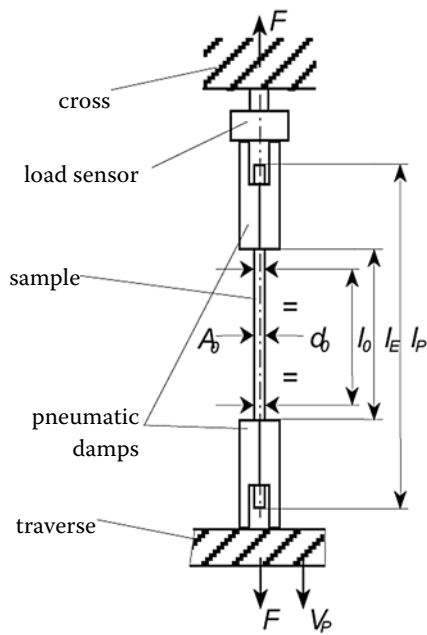

Figure 3. Schematic view of the sample in the universal testing machine

The mass  $m$  is the product of cross-sectional area  $A_0$  times length  $l$  times density  $\rho_{S/F}$ .

$$T_t = m_{S/F}/l_{S/F} = A_0 \times \rho_{S/F}$$

### Mechanical properties

Tensile strength  $\sigma_H$  is the quotient of the maximal force  $F_{max}$  of the tensile test and the cross-sectional area  $A_0$  at the beginning of the test. The maximal force  $F_{max}$  is measured in an extension test using a universal material testing machines of manufacturer like ZWICK or MTS. For the natural fibre research at Bonn University was used a ZWICK model 1445 with the machine adjustment and clamp specification in Table 2 and 3. For natural fibre,  $F_{max}$  is identical in most cases with the breaking force (Figure 3), (DIN 50 145 1975; DIN 53 455 1981; ASTM D 3822 1993; BECKMANN 1998; KROMER & HEIER 2001).

The cross-sectional area may be also calculated as the quotient of the fibre fineness and the fibre density according to DIN 53 816 (1976).

Fineness-related maximal force  $R_H$  is the quotient of maximal force  $F_{max}$  and fineness  $T_t$  before the test run. DIN 53 815 (1989) may be used to define the term, fineness strength.

Extension  $\varepsilon_H$  at maximal tensile force is the quotient of the change of length  $\Delta l_H$  ( $l_0 - l_H$ ), maximal force, and the sample length  $l_0$  extension (in %).

Modulus of elasticity (Young's modulus) E-Modulus  $E_{40/60}$  is calculated on the basis of the ascent in

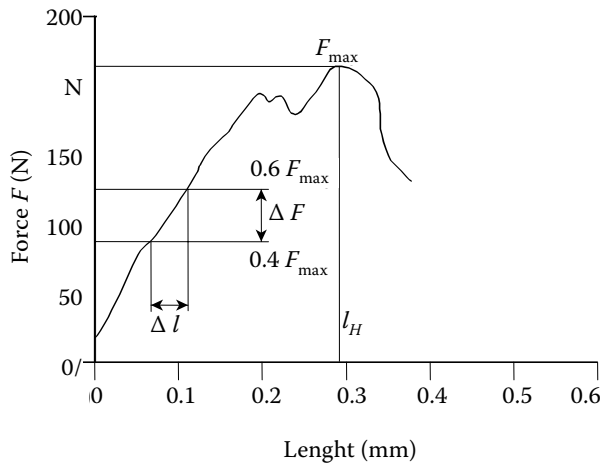

Figure 4. Typical force – deformation (elongation) curve

the tension-extension-diagram. Young's modulus of elasticity is a measure of the stiffness and describes the resistance to the change of length. The force-deformation curves for the tests of flax stems as well as fibre bundle have a sufficient linear slope for the calculation of the tensile strength in the range of 40% to 60%, Figure 4.

$$\sigma_H \text{ at } F_{max} = F_{max}/A_0$$

$$R_H = F_{max}/T_t = F_{max} \times l_{S/F}/m_{S/F}$$

$$\varepsilon_H \text{ at } F_{max} = (l_H - l_0) 100/l_0 = \Delta l_H \times 100/l_0$$

$$E_{40/60} = (\sigma_{60} - \sigma_{40})/\varepsilon(\sigma_{60}) - \varepsilon(\sigma_{40})$$

For the fibre bundle test, a quality evaluation of the breakage is necessary, to assure 24 valid test runs. Not accepted are the bundles non-correctly broken due to splitting up, breakage in or within 1 mm of the clamp, clean breakage without split, slipping in the clamps.

### Mechanical properties of fibre-reinforced plastic

The circular plate bending test for fibre-reinforced composites is a standardised testing method with a plane tension (thickness vs. plate diameter small) and a quasi-static load. It is used to measure the mechanical properties of the circular plate – bending strength – extension and – modulus of elasticity of fibre reinforced polypropylene (PP), Figure 5. The existing standards on plastic material have to be known (DIN 53 452 1977; DIN 53 457 1987; WIELAGE *et al.* 2001).

The test requires 3 circular plates (diameter  $\varnothing$  90 mm), taken randomly from the reinforced plastic with no damage at the edges. They have to be conditioned for 16 h at 23°C and 50% relative

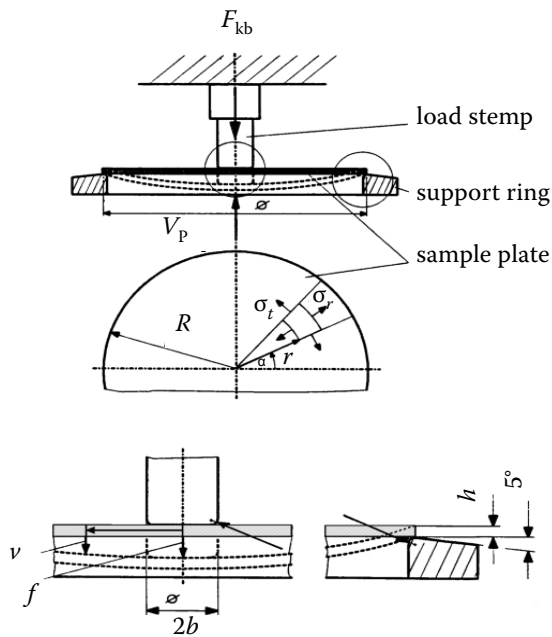

Figure 5. Schematic view of the circular plate bending test

humidity, standard according to DIN 50 014 (1985). The test plate thickness has to be measured with an accuracy of 0.01 mm, 3 times with 120° increments. For a safe support, the plate is cut out with a radial plus 3 mm due to the support ring diameter.

The circular plate bending strength  $\sigma_{KBmax}$  is defined as the maximal stress in the center of the circular plate and is calculated versus the maximal bending force  $F_{KBmax}$ , the plate thickness  $h$ , diameter  $2 \varnothing_2$ , Poisson number  $\nu$ , radius of the loading stamp  $b$ , and support radius  $R$ .

The extension at maximal bending force  $\epsilon_{KBmax}$  ( $\epsilon_{KB}$  at  $\sigma_{KBmax}$ ) is calculated vs. the bending distance in the plate center  $f_{max}$  (a function of  $F_{KBmax}$ ), plate

thickness  $h$ , Poisson number  $\nu$ , and the 2 radius  $b$  and  $R$  (BECKMANN 1998).

Circular plate modulus of elasticity,  $E_{KB}$ , is defined as the secant modulus between two points on the bending stress – extension-curve. Two secant moduli were calculated, the first start modulus  $E_{KB5/25}$  between 0.05% and 0.25% extension, the second  $E_{KB10/50}$  for better information about stiffness between 10% and 50% extension. The bending forces  $F_{KB1}$  and  $F_{KB2}$  are taken from the force-bending curve at  $f_1$ , respectively  $f_2$ . The secant modulus of elasticity  $E_{KB10/50}$  is defined as the secant between the bending strength  $\sigma_{KB10} = 0.1 \sigma_{KBmax}$  and  $\sigma_{KB50} = 0.5 \sigma_{KBmax}$ . The bending through distances  $f_{10} = f(0.1 F_{KBmax})$  und  $f_{50} = f(0.5 F_{KBmax})$  are picked from the force-bending through – curve, bending force  $F_{KB}$  has to be centrally symmetric, Figure 6.

In the plate plane, there exist radial as well as tangential strengths, both reaching their maximum in the center ( $r = 0$ ). Due to the rotation symmetry  $\sigma_{KB} = \sigma_r = \sigma_t$ . For the test, the description of adjustment – curve is shown in Figure 6.

Measuring the Poisson number, strain gauges are used to measure the longitudinal and cross extensions in the tension test. One sample per reinforced plastic plate to be tested is required. The calculation is done for the elastic range at 0.25% longitudinal extension.

Decisive for the reinforcement of plastic by the use of fibre material is the fibre-matrix-binding. The fibre-matrix-binding (SCHLÖSSER *et al.* 1995; WIELAGE *et al.* 2001) is defined as the binding quality between the reinforcing fibre and the matrix material. The binding mechanisms in the boundary layer are chemical covalent binding, secondary

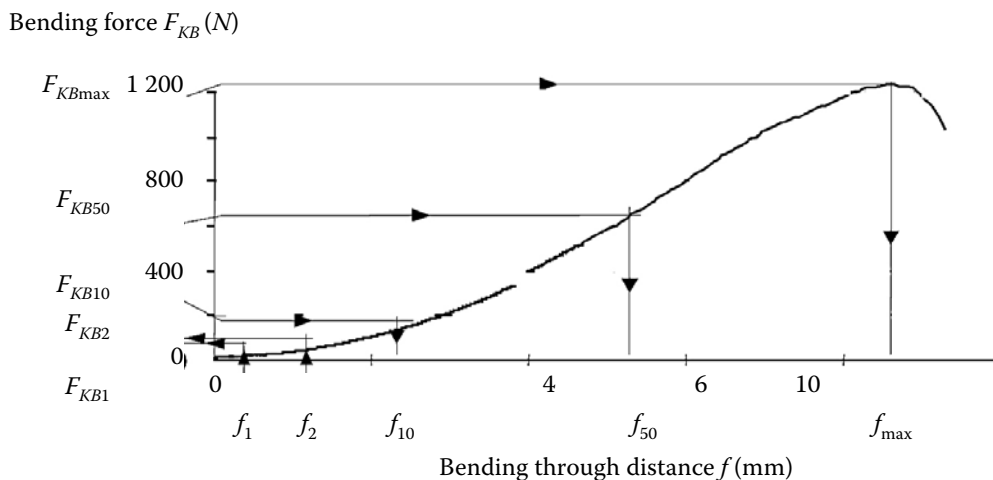

Figure 6. Typical force-deformation (bending through distance) curve (BECKMANN 1998)

Table 4. Adjustments of the universal testing machine (ZWICK 1445) for the circular plate bending test

Radius of circular plate (mm)	45.0
Radius of support ring $R$ (mm)	42.0
Radius of load stamp $b$ (mm)	10.0
Radius of edges $r_1, r_2$ (mm)	2.0
Testing speed $v_p$ (mm/min)	10.0
Lead load $F_{\text{KLead}}$ (N)	10.0
Error of measuring bending through distance $f$ (%)	by using travers movement < 1
Error of measuring bending force $F_{\text{KB}} < 10\text{kN}$ (%)	by using load sensor < 0.2

Table 5. Average, range and standard deviation (SD) of 59 flax fibre samples, BECKMANN (1998)

Fibre property	Average	Minimum	Maximum	SD
Equiv. diameter $d_F$ (mm)	0.133	0.092	0.177	0.023
Fineness $T_t$ (tex)	9.73	3.73	17.57	3.30
Tensile strength $\sigma_H$ (MPa)	451.00	286.00	585.00	78.00
Maximal force related to fineness $R_H$ (cN/tex)	65.00	44.40	95.30	12.50
Extension at maximal force $\epsilon_H$ (%)	1.92	1.63	2.48	0.19
E – Modulus $E_{40/60}$ (MPa)	24.610	17.655	32.005	3.213

chemical binding, adsorption, wetting, interdiffusion, electrostatic attraction, and mechanical binding. A disadvantage is the low affinity of flax fibre, elementary fibre or fibre bundle, and PP. PP is non polar, OH-groups of cellulose are strongly polar. Therefore, binding agents are often used. On the other hand, PP is also a preferable polyolefin for fibre reinforcement of geometrically difficult parts in extrusion. In addition, fibre orientation will also have an influence.

The probe plate is manufactured by film stacking method, the fibre content is limited to a maximum weight percentage of 35% fibre. The press temperature varied from 170°C to 185°C with an influence on the PP-viscosity. The fibre was applied with a fleece of tangled fibre.

### Statistical evaluation

The statistical evaluation has to be done by regression analysis, standard deviation, correlation analysis, and factor-variance-analysis. The factor steps and replications are due to the testing of biological material. For flax, the genotype and the location have often a significant influence. In the test and evalua-

tion praxis, standard software packages were used like SPSS and SAS. (KOCH *et al.* 1995; BECKMANN 1998; KROMER & HEIER 2001)

### Selected test results

The application of the discussed methods will be demonstrated with the selected test results, since they were used on a large scale, mainly in integrated programs with the plant breeding, production technology, fleece production, and application of fibre-reinforced plastics in cars and trucks (MIECK *et al.* 1995).

### Variability of physical properties

For calculating some of the mechanical properties, the equivalent cross-sectional diameter of the flax fibre  $d_F$  in the test runs with the fibre bundle assuming to be a circle, must be known, see Figure 2. The diameter is also necessary for calculating the fineness  $T_t$ . For the tensile test, the universal testing machine ZWICK 1445 was used with the adjustments given in Table 2.

The data shown in Table 5 are based on the correlation analysis of 59 samples with 24 tensile test runs

Table 6. Pearson's correlation coefficient between the mechanical properties of flax stems (*S*) and flax fibre bundles, BECKMANN (1998)

Flax stem property	Correlation coefficient	Fibre bundle property
$\epsilon_{HS}$ (%)	0.31*	$\epsilon_{HF}$ (%)
$\sigma_{HS}$ (MPa)	0.29	$\sigma_{HF}$ (MPa)
$E_{40/60S}$ (MPa)	0.14	$E_{40/60F}$ (MPa)

\*significance level at 5%;  $\epsilon_H$  – extension at maximal pulling force  $F_H$ ;  $\sigma_H$  – tensile strength;  $E_{40/60}$  – modulus of elasticity;  $R_H$  – fineness related maximal force

each. The samples were randomly taken of 21 genotypes, 2 growing locations, 2 years, 2 seeding densities, 24 replications. Discussing the results, there is a large variability of those properties investigated and it may be a problem to produce annually flax fibre with narrowly defined property values in different localities.

#### Correlation between stem and fibre properties

For the quality strategies and quality management, a field measurement of mechanical properties would be requested. Due to the methods, the test on stems

would be the first choice if the properties of the flax stem, indices *S* and flax fibre (bundle), indices *F* correlate sufficiently.

The results of the correlation analysis are shown in Table 6. 40 samples were randomly taken, followed by 24 and respectively, 20 tensile tests for fibres and stems. Discussing the results, there is no correlation between the data on stems and fibres. Therefore, the measurement has to be taken on the plant parts in view of the later application.

Mechanical properties vs. fibre weight percentage in the composite material and the temperature

Table 7. Three-factorial-variance-analysis of mechanical properties, BECKMANN (1998)

Tensile test DIN 53452					
Mechanical property variable	DF	$\sigma_{Zugmax}$	$\epsilon_{Zugmax}$	$E_{Zug5/25}$	$E_{Zug10/50}$
Fibre weight percentage FA	2	***	***	***	***
Pressing temperature TEMP	1	–	–	–	–
FA × TEMP	2	–	–	–	–
Bending test DIN 53 455					
Mechanical property variable	DF	$\sigma_{3Pktmax}$	$\epsilon_{3Pktmax}$	$E_{3Pkt5/25}$	$E_{3Pkt10/50}$
Fibre weight percentage FA	2	***	***	***	***
Pressing temperature TEMP	1	–	–	–	–
FA × TEMP	2	–	–	–	–
Circular plate test by BECKMANN (1998)					
Mechanical property variable	DF	$\sigma_{KBmax}$	$\epsilon_{KBmax}$	$E_{KB5/25}$	$E_{KB10/50}$
Fibre weight percentage FA	2	***	***	–	***
Pressing temperature TEMP	1	–	–	–	–
FA × TEMP	2	–	–	–	–

– Not significant; \*significance level at 5%; \*\*significance level at 1%; \*\*\*significance level at 0.1%

$\sigma_{max}$  – tensile strength at  $F_{max}$ ;  $\epsilon_{max}$  – extension at  $F_{max}$ ;  $E_{5/25}$  – start secant E-modulus of elasticity;  $E_{10/50}$  – second secant E-modulus; DF – degree of freedom; BECKMANN (1998)

during the film-stacking-process (DIN 53 452 1977; DIN 53 455 1981; BECKMANN & KROMER 1995; BECKMANN 1998)

As an example of the effect of the test method used, particularly under the aspect of validating the proposed circular plate bending test, selected mechanical properties of fibre reinforced plastic were investigated. The results of 54 circular plate bending tests (BECKMANN 1998) were compared with 108, each based on the tensile test DIN 53 455 (1981) and 3-point-bending tests DIN 53 452 (1977).

For the 3 factorial variance analysis, the factors included 2 maximal temperatures in the press (170°C and 185°C), 3 replications, 3 fibre weight percentages (0%, 25% and 35%), no binding agent. As the result, the temperature had no effect and can not be utilised for a better binding effect. Highly significant was the fibre weight percentage. Discussing the results, the circular plate bending test gives comparable data for maximal tensile strength, extension at maximal force, and the second E-modulus, a measure for stiffness as discussed. The force-bending through-curve seems to be different at the start, therefore  $E_{KB5/25}$  is not significant, Table 7.

## CONCLUSION

The rapidly increasing application of natural fibre-reinforced plastic offers advantages in the density, weight, costs, availability, degradability, biodiversity, also in meeting car part regulations, but definite physical properties must be provided. The knowledge of these mechanical properties is a precondition for the sustainable application of natural fibre. For a comparable data acquisition, the measuring methods have to be standardised. They are also extremely important for optimisation strategies in the fibre production. The paper summarises the sampling procedures and the existing methods for measuring the geometrical, gravimetical, and mechanical properties of flax fibre, including a ring plate test of natural fibre-reinforced plastic. This method to measure the mechanical properties of composites, recognises the fibre-matrix-binding due to the film stacking process of fibre fleece and PP.

### List of selected symbols

$A_0$	– cross-sectional area (mm <sup>2</sup> )
$b$	– radius of the loading stamp (mm)
$E_{40/60}$	– modulus of elasticity
$f_{\max}$	– bending distance (mm)
$F_{\max}$	– maximal force of tensile test (N)
$F_{KB\max}$	– maximal bending force (N)

$F_{KB1}$	– circular plate bending force at bending distance $f_1$ (N)
$F_{KB2}$	– circular plate bending force at bending distance $f_2$ (N)
$h$	– plate thickness (mm)
$l_0$	– sample length at test start (mm)
$l_H$	– sample length at maximal force $F_{\max}$ (mm)
$l_{S/F}$	– length of the stem or fibre bundle section (m)
$\Delta l_H$	– length change of the probe during the test (mm)
$m$	– mass of probe, fresh (g)
$m_T$	– mass after drying process (g)
$m_{4x10}$	– mass after decortication, 10 runs through 4 pairs of rollers (g)
$m_E$	– mass of sample (g), taken $\geq 20$ g of stems per sample-meter in the field
$m_{S/F}$	– mass of stem or fibre bundle section in the test (mg)
$R$	– radius of the support ring (mm)
$T_t$	– fineness $T_t$ of the stem or the fibre bundle (tex)
$\varepsilon_H$	– quotient of change of length $\Delta l_H$ and length at test start $l_0$
$\varepsilon(\sigma_{60})$	– extension at the tension of 60% $\sigma_{60}$ (%)
$\varepsilon(\sigma_{40})$	– extension at the tension of 40% $\sigma_{40}$ (%)
$\nu$	– Poisson number
$\rho_{S/F}$	– density of the stem or the fibre bundle (kg/dm <sup>3</sup> )
$\sigma_H$	– tensile strength at maximal force $F_{\max}$ (MPa)
$\sigma_{60}$	– tension at 60% of the tensile strength (MPa)
$\sigma_{40}$	– tension at 40% of the tensile strength (MPa)
$\sigma_{KB1}$	– circular plate bending strength 1 (N per mm <sup>2</sup> )
$\sigma_{KB2}$	– circular plate bending strength 2 (N per mm <sup>2</sup> )
$\sigma_{KB50}$	– 50% of bending strength $\sigma_{KB\max}$ (N/mm <sup>2</sup> )
$\sigma_{KB10}$	– 10% of bending strength $\sigma_{KB\max}$ (N/mm <sup>2</sup> )
$\varepsilon_{KB1}$	– circular plate extension at 0.05 (%)
$\varepsilon_{KB2}$	– circular plate extension at 0.25 (%)
$\varepsilon_{KB50}$	– circular plate extension at $f_{KB50}$ (%)
$\varepsilon_{KB10}$	– circular plate extension at $f_{KB10}$ (%)

### References

- ASTM D 3822 (1993): Standard Test Method for Tensile Properties of Single Textile Fibres. Annual Book of ASTM Standards, Engllwood VS & Brackell.
- BECKMANN A., KROMER K.-H. (1995): Evaluation of test standards for measuring the fibre content and strength



- values of flax. *Research in Agricultural Engineering*, 41: 21–24.
- BECKMANN A. (1998): Methoden zur Messung physikalischer Eigenschaften von Industriefaser-Lein (Flachs) und damit verstärkten Kunststoffen. [PhD Thesis.] RWTH Aachen, Forschungsbericht Agrartechnik VDI-MEG Nr. 326, Institut für Landtechnik, RFW University Bonn, Bonn.
- DAMBROTH M., SEEHUBER R. (1988): Flachs: Züchtung, Anbau und Verarbeitung, Eugen Ulmer Verlag, Stuttgart.
- DIN 60 905 (1970): Tex-System zur Bezeichnung der längenbezogenen Masse von textilen Fasern, Zwischenprodukten, Garnen, Zwirnen und verwandten Erzeugnissen. Beuth-Verlag GmbH, Berlin, Köln.
- DIN 50 145 (1975): Zugversuch, Prüfung metallischer Werkstoffe. Beuth-Verlag GmbH Berlin, Köln.
- DIN 53 816 (1976): Einfacher Zugversuch an einzelnen Fasern im klimatisierten oder nassen Zustand, Prüfung von Textilien. Beuth-Verlag GmbH Berlin, Köln.
- DIN 53 452 (1977): Prüfung von Kunststoffen; Biegeversuch. Beuth-Verlag GmbH Berlin, Köln.
- DIN 53 455 (1981): Prüfung von Kunststoffen; Zugversuch. Beuth-Verlag GmbH Berlin, Köln.
- DIN 50 014 (1985): Normalklimat. Beuth-Verlag GmbH Berlin, Köln.
- DIN 53 457 (1987): Prüfung von Kunststoffen, Bestimmung des Elastizitätsmoduls im Zug-, Druck- und Biegeversuch. Beuth-Verlag GmbH Berlin, Köln.
- DIN 53 815 (1989): Prüfung von Textilien, Begriffe für den einfachen Zugversuch. Beuth-Verlag GmbH Berlin, Köln.
- GASSAN J. (2003): Naturfasern im Automobil – Innenraum. *Leichtbau. Kunststoffe*, 93: 77–80.
- HENKEL R.-C. (2007): Ein ungeliebter Werkstoff macht Karriere – Hightech aus Plastic. *VDI Nachrichten* Nr. 42, VDI Verlag, Düsseldorf.
- KOCH K., BECKMANN A., KROMER K.-H. (1995): Untersuchungen zur Entwicklung einer Methode für die Bestimmung des Faseranteiles und der Entholzbarkeit von Leinstroh. *Arbeiten aus dem Institut für Landtechnik der RFW Universität Bonn*, Heft Nr. 17.
- KARUS M., KAUP M., ORTMANN S. (2003): Naturfasereinsatz in Verbundwerkstoffen in der deutschen und österreichischen Automobilindustrie Status 2002, Analyse und Trends. Nova-Institut, Hürth.
- KROMER K.-H., HEIER L. (2001): Optimierungsstrategien der Produktion, Verwertung und des Recycling von technisch nutzbarem Kurzfaserlein. [Forschungsendbericht der Teilprojekte IB, IC – Produktlinienmodell Industriefaserlein, Projekt Nr. FKZ 95NR133-F-A der FNR.] Fachagentur für Nachwachsende Rohstoffe, Institut für Landtechnik, Bonn.
- KROMER K.-H. (ed.), HEYLAND K.-U. (ed.), BECKMANN A., FRANKEN S., KRUKELMANN E., SCHEER-TRIEBEL M. (1995a): Züchtung von zur Kurzfasergewinnung geeigneten Leinsorten unter Berücksichtigung technischer Stoffeigenschaften. [BML – Forschungsendbericht 0319441B.] Bonn.
- KROMER K.-H., GOTTSCHALK H., BECKMANN A. (1995b): Technisch nutzbare Leinfaser – Eine neue Flachskurzfasertechnologie. *Landtechnik*, 50: 340–341.
- KROMER K.-H., HEINTGES M., HEIER L., BECKMANN A. (2002): Methodenbuch Industriefaserlein. *Arbeiten aus dem Institut für Landtechnik der RFW Universität Bonn*, Heft Nr. 29, 2<sup>nd</sup> Ed., Bonn.
- MIECK K.-P., NECHWATAL A., KNOBELSDORF, C. (1995): Eigenschaften und Oberflächenmodifizierung von Flachsfasern für Verbundwerkstoffe. In: *Statusseminar – Flachs*. November 15–16, 1993, Leipzig, 274–290.
- MÜSSIG, J., HARIG, H. (2000): Technical Products based on natural fibres. In: *Proc 2<sup>nd</sup> Int. Symposium Biotechnology for Conservation of the Environment*. July, 9–12, 2000, Münster.
- PÜTZ P. (1993): Datenbank für physikalische Eigenschaften von festen landwirtschaftlichen Stoffen und deren Anwendung für Faserlein. [PhD Thesis.] RFW University Forschungsbericht Agrartechnik VDI-MEG Nr. 326, Institut für Landtechnik, RFW University Bonn, Bonn.
- SCHNEGELSBURG G. (1999): *Handbuch der Faser – Theorie und Systematik der Faser*. Bd. 1, Deutscher Fachverlag, Frankfurt am Main, 512–513.
- SCHLÖSSER TH. P., FÖLSTER TH., GAYER U. (1995): Naturfaserverstärkte Kunststoffe für automobiltechnische Anwendungen. [Abschlussbericht des FNR-Verbundprojektes L 0310545A, Daimler-Benz AG.] *Forschung und Technik*, Ulm.
- VDLUFA (1988): *Methodenbücher*. VDLUFA-Verlag, Darmstadt.
- WIELAGE B., MENNING G., AURICH T., LAMPKE TH. (2001): Einflussfaktoren auf die Eigenschaften spritzgegossener naturfaserverstärkter Thermoplaste. In: KROMER K.-H., HEIER L. (eds.): *Proc. 4th European Symposium on Industrial Crops and Products*. March 23–25, 1999, Bonn. *Arbeiten aus dem Institut für Landtechnik der RFW Universität Bonn*, Heft Nr. 29, 42–49

Received for publication February 12, 2008

Accepted after corrections March 9, 2009

## Abstrakt

KROMER K.-H. (2009): **Vybrané fyzické vlastnosti lněných vláken v netextilním využití.** Res. Agr. Eng., 55: 52–61.

Průmyslové využití přírodních vláken v průmyslu roste nepřetržitě od roku 1996 a procentuální podíl vláken v interiérech automobilů dosahuje až 40 %. Řízení kvality vyžaduje standardy pro měření fyzických vlastností vláken. Článek shrnuje vhodné a vyzkoušené metody pro měření geometrických, gravimetrických a mechanických vlastností lněných vláken. Testovací standardy jsou nutné rovněž pro vyztužené plasty. Z toho důvodu je uvedena další metoda, která byla srovnána se stávajícími standardy. Uvedené metody jsou předvedeny na vybraných souborech měřených dat.

**Klíčová slova:** fyzické vlastnosti; lněná vlákna; vlákny vyztužené plastické hmoty; metody měření; standardizace; aplikace metod

---

*Corresponding author:*

Prof. Dr. Ing. KARL-HANS KROMER, Institut für Landtechnik der RFW University Bonn, Nussallee 5, D-53115 Bonn, Germany  
e-mail: kromer@uni-bonn.de

---