

RINGRAZIAMENTI

Innanzitutto vorrei ringraziare il mio relatore, Prof. Vittorio Curri, sia per avermi proposto questa tesi molto stimolante sia per avermi permesso di svolgere questo lavoro in assoluta serenità, mettendomi sempre nelle migliori condizioni per poter lavorare attraverso la sua passione e il suo aiuto, dandomi inoltre la possibilità di partecipare alla stesura di due articoli scientifici sul progetto su cui si basa il lavoro di tesi. Ringrazio poi il Centro Interdipartimentale per la Power Electronics (PEIC) del Politecnico di Torino per avermi permesso di svolgere questo progetto stimolante sotto vari punti di vista. Vorrei ringraziare i miei correlatori, Prof. Eric Giacomo Armando e Prof. Gianmario Pellegrino del Dipartimento Energia (DENERG), l'Ing. Paolo Savio dell'Istituto Superiore Mario Boella (ISMB) e lo studente di dottorato Anantaram Varatharajan (DENERG), per avermi supportato durante questi sei mesi di lavoro attraverso le loro competenze, dandomi sempre l'apporto necessario e chiarendo sempre ogni mio dubbio. Infine vorrei ringraziare le persone dell'ISMB, in particolare il personale dell'area di ricerca "Applied Photonics" per avermi dato la possibilità di portare avanti il lavoro di tesi presso i loro uffici e per avermi fatto sentire come uno di loro.

Ringrazio voi Mamma e Papà per avermi dato la possibilità di studiare senza mai mettermi pressione stando sempre dalla mia parte, e per avermi dato la possibilità di studiare lontano da casa permettendomi di fare delle esperienze di vita che senza il vostro aiuto non avrei mai potuto fare. Voglio ringraziarvi per essermi sempre stati accanto e per avermi sempre spronato (alla fine tutti quei litigi sono serviti). Purtroppo ci ho messo un pò più del dovuto a laurearmi, ma solo per continuare a sentire le frasi più famose di papà come "apri il libro" o "studia!", e ora infatti già mi mancano (anche se in realtà ci sono ancora Gemma e Albino). Grazie infine per non avermi mai fatto mancare niente nonostante alle volte non sia stato il figlio perfetto. Spero di restituirvi giorno per giorno un pò di tutto quello che avete fatto per me, e rendervi orgogliosi di me, così come io lo sono di voi.

Ringrazio Albino e Gemma, per essere di più di un semplice fratello e una semplice sorella. Siete sempre stati con me, mi avete sempre appoggiato senza se e senza ma. E' vero non usciamo spesso insieme, ma so benissimo che voi ci sarete sempre per me così come io per voi. Vi ringrazio perchè questi 5 anni lontano da casa non hanno minimamente scalfito il nostro bellissimo rapporto, e il tornare a casa e raccontarci le nostre esperienze è sempre emozionante. Voglio infine dirvi, Mamma, Papà, Albino e Gemma, che questa lontananza che

ormai dura da 5 anni, non si fa sentire solo per voi, ma è dura da sopportare (anche se cerco di nascondere) anche per me. Ma sappiamo tutti che non sarà certo qualche kilometro a dividerci: vi voglio bene!

Ringrazio la mia bellissima famiglia allargata, nonna Gemma, zia Graziella, zia Rita, zio Chichino, Mario e Matteo (e anche chi non c'è più ma è come se fosse sempre con noi). Vi ringrazio perchè avete sempre creduto in me, dandomi sempre il vostro sostegno, anche quando questo traguardo sembrava irraggiungibile.

Ringrazio il mio amore, Maria Chiara, perchè da 2 anni e mezzo mi supporta e mi sopporta costantemente. Conosco bene il mio carattere, alle volte sono proprio insopportabile (forse in famiglia ne sanno qualcosa) ma tu nonostante questo non hai mai smesso di credere in me e di tirarmi su quando volevo mandare tutto all'aria, convincendomi delle capacità che ho. Ti ringrazio perchè con la tua presenza nella mia vita, mi hai fatto scoprire cose nuove, mi hai fatto capire cosa significa esserci sempre, mi hai fatto capire che per stare bene ed essere felici non bisogna fare per forza le 5 del mattino, ma basta un letto, una coperta (di paaaail) e una televisione. Ti ringrazio perchè addormentarmi e svegliarmi al tuo fianco è qualcosa di indescrivibilmente bello. Ti ringrazio, Maria Chiara, perchè mi hai insegnato cosa significa AMARE.

Ringrazio i miei Amici, quelli nuovi (terroni e polentoni), conosciuti in questa esperienza da fuori sede, con cui ho passato serate fantastiche in giro per Torino o semplicemente a casa tra un bicchiere di vino e tante risate. Ringrazio poi gli Amici di sempre che nonostante la lontananza sono sempre stati presenti e pronti a supportarmi, ed ogni volta che torno a casa mi fanno sentire come se non me ne fossi mai andato.

Ringrazio i miei bellissimi coinquilini: Gerardo, Giulio, Luciano, Manuel, Pietro e Riccardo. Conoscervi è stata una delle cose più belle di questa esperienza torinese; legare con voi è stato facilissimo, infatti nonostante fossi nuovo della casa mi avete fatto sentire subito a mio agio. Vi ringrazio perchè mi conosco e so quanto rompo le scatole per determinate cose, ma nonostante questo mi avete sempre dato il vostro sostegno, permettendo la nascita di un rapporto solido e di amicizia.

Finisce qui il mio percorsi di studi. Ringraziare tutti con poche parole non è mai semplice, quindi spero di esserci riuscito e di avervi fatto capire quanto siete importanti per me. Grazie di cuore a tutti per essere sempre stati dalla mia parte, senza di voi niente di tutto questo sarebbe stato possibile.

Erasmus Vizzaccaro
Torino, Ottobre 2018.

CONTENTS

1	POWER ELECTRONICS: INTRODUCTION AND BACKGROUND	1
1.1	The need for Power Electronics	1
1.2	What is Power Electronics?	2
1.3	Power Electronic Converters and their Applications . .	7
1.3.1	DC-DC Converter	9
1.3.2	DC-AC Converter	10
1.3.3	AC-DC Converter	13
1.3.4	AC-AC Converter	13
1.3.5	Voltage Regulator and Power Supply	14
1.4	Power Electronic Converters for Electric Motor Drives	18
1.4.1	Brushless DC Motor	19
1.4.2	Motor Control Overview	21
1.5	A method to control a Brushless DC motor: Pulse Width Modulation	24
1.5.1	Pulse Width Modulation	26
2	FIBER-POWER: APPLICATION OF OPTIC FIBERS TO POWER ELECTRONICS	29
2.1	Power Electronics Control Architecture	29
2.1.1	Design of PEBB based Power Electronics Systems	30
2.1.2	Distributed digital controller in motion control system	31
2.2	Communication topologies	34
2.2.1	Star Structure	35
2.2.2	Bus Structure	36
2.2.3	Ring Structure	36
2.2.4	Daisy-chain Structure	36
2.3	An overview of communication protocols for Power Converters	37
2.3.1	Controller Area Network (CAN)	38
2.3.2	Serial Real-time Communication System (SERCOS)	39
2.3.3	Motion And Control Ring Optical (MACRO) . .	39
2.3.4	Power Electronic System Network (PESNet) . .	40
2.4	Thesis purpose	41
2.4.1	Example: Control of a PWM power converter .	42
2.5	Optical Communications	47
2.5.1	Description and characteristics of optical fibers	47
2.5.2	Behavior	50
2.5.3	Attenuation	51
2.5.4	Glass Optical Fiber	52
2.5.5	Plastic Optical Fiber	54
2.5.6	Transmission Windows for Plastic and Glass Op- tical Fibers	55

2.5.7	State of the Art of Plastic Optical Fibers	59
3	SHARED CONTROL OF PECS THROUGH A PHOTONIC BUS	61
3.1	Introduction	61
3.2	Data Communication in PECs and Design of Shared Control Architecture	63
3.3	An overview about FPGA and VHDL	65
3.3.1	Field Programmable Gate Array	65
3.3.2	Very-High-Speed-Integrated-Circuit Hardware Description Language	68
3.4	Photonic bus: Implementation and Protocol	71
3.4.1	Protocol Description	72
3.4.2	Implementation	76
3.5	Demonstrator Setup	78
3.5.1	Finite State Machine	84
3.5.2	Experimental Results	85
4	TOWARDS THE INTERNET OF POWER: CONCLUSION AND FURTHER DEVELOPMENTS	89
4.1	Internet of Things: An Overview	90
4.2	Internet of Energy: Internet of Things in Power Sectors	91
4.2.1	State of the Art of Internet of Energy	92
4.3	Further Developments	93
4.3.1	A cloud approach for controlling Power Electronic Converters	94
4.4	Conclusion	96
	BIBLIOGRAPHY	

LIST OF FIGURES

Figure 1.1	Power Electronics as interface between the source and the load.	2
Figure 1.2	Power Electronics World	4
Figure 1.3	Power Electronics Applications	5
Figure 1.4	Power Semiconductor Devices and their Applications	6
Figure 1.5	Ideal Switch: Circuit and Characteristic	7
Figure 1.6	Power electronics and electrical energy generation transmission, storage, and distribution	8
Figure 1.7	DC-DC Converter	9
Figure 1.8	DC-AC Converter	11
Figure 1.9	AC-DC Converter	13
Figure 1.10	AC-AC Converter	14
Figure 1.11	Motor Classification	18
Figure 1.12	Comparative analysis of motors	19
Figure 1.13	Brushless DC motors	20
Figure 1.14	Construction of Brushless DC motor	20
Figure 1.15	Block diagram of a motor drive system	22
Figure 1.16	A periodic pulse train	24
Figure 1.17	Three pulses with different Duty Cycle	24
Figure 1.18	Pulse Width Modulation technique	26
Figure 2.1	Common converter topologies, (<i>Celanovic 2000</i>)	32
Figure 2.2	New system architecture, (<i>Celanovic 2000</i>)	33
Figure 2.3	Application Manager, (<i>Celanovic 2000</i>)	33
Figure 2.4	Communication topologies: Structure and features, (<i>Vaidya 2017</i>)	35
Figure 2.5	CAN configuration for power converters and its node structure, (<i>Vaidya 2017</i>)	39
Figure 2.6	PESNet topology and functioning of data cycle, (<i>Vaidya 2017</i>)	40
Figure 2.7	DC-DC Buck Converter	43
Figure 2.8	System layout with optic fiber communication	44
Figure 2.9	A typical PWM modulation	44
Figure 2.10	Sampling time scale	45
Figure 2.11	Synchronization of sampling and PWM output update	46
Figure 2.12	Electromagnetic Spectrum	48
Figure 2.13	Optical Fiber	49
Figure 2.14	Structure of a typical single-mode fiber	50
Figure 2.15	Total internal reflection (a) and external reflection (b)	51

Figure 2.16	Optical fibers comparison	53
Figure 2.17	Index profiles for plastic optical fibers	54
Figure 2.18	Comparison between core/cladding of plastic and glass optical fiber	55
Figure 2.19	Expansion of Data applications for POF and connector interfaces for A4a POF	56
Figure 2.20	Transmission windows for a silica optical fiber	58
Figure 2.21	PMMA-SI-POF attenuation spectrum	58
Figure 3.1	Common control layers for a PEC. Conventional and proposed are highlighted	64
Figure 3.2	FPGA and its CLB representations	66
Figure 3.3	FPGAs market	67
Figure 3.4	Xilinx Zynq-7000 structure	68
Figure 3.5	A generic Vivado window with the Flow Navigator on the left	70
Figure 3.6	Scheme for the proposed TDM control setup based on a daisy-chain connected by POF links	71
Figure 3.7	Communication cycle timing diagram of the proposed optical link	73
Figure 3.8	Sensitivity of T_{transm} to fiber length and bit-rate in a one-way transmission between two nodes	74
Figure 3.9	Simulation timing diagram with Vivado	74
Figure 3.10	Example of packet flow	76
Figure 3.11	Demonstrator Setup	79
Figure 3.12	Developed PCB with the X-Nucleo-IHMo8M1	80
Figure 3.13	Control Unit scheme by Vivado Design Suite .	82
Figure 3.14	Finite State Machine - Upstream flow	85
Figure 3.15	Finite State Machine - Downstream flow	85
Figure 3.16	Measured latency with Vivado simulator	87
Figure 3.17	Measured latency with the oscilloscope	87
Figure 4.1	Components of the IoT cloud	91
Figure 4.2	IoE Architecture	92
Figure 4.3	The daisy chain control scheme (on the right) as an element of the power electronic cloud . .	95

POWER ELECTRONICS: INTRODUCTION AND BACKGROUND

This chapter gives an overview about the power electronics world. Firstly, the need and the meaning of power electronics are explained. Then, different power converters are described with particular attention to the converters used in the electric motor drives. Finally, a method to control a power electronic converter is described, i.e Pulse Width Modulation.

1.1 THE NEED FOR POWER ELECTRONICS

Electricity has changed everything and it will again, completely changing the way people live and work. Today, we are in the early stages of a new energy revolution, and we can see it in the explosive growth of portable devices, industry processes, in hybrid cars on the road, in jetliners that are moving to all-electric, and much of the revolution is based on using electronic circuits to process energy. Nowadays, since people don't use "directly" electricity but light, heat, information and other more palpable types of energy, power electronic and energy conversion are becoming more and more important for our lives.

Everything started when a British scientist, Michael Faraday, in 1821 explained the conversion of electrical energy into mechanical energy by placing a current carrying conductor in a magnetic field, which resulted in the rotation of the conductor due to the torque produced by the mutual action of electrical current and magnetic field. Based on his principles, the most primitive DC motor began to be developed. So, it is undoubtedly true that electrical energy plays a very important role in our daily life for a lot of reasons, such as:

- Facility of transport, in fact a city can be fed with few metal wires carrying energy;
- It can be converted back and forth into mechanical energy or other energy forms with high efficiency;

Unfortunately, there are also some drawbacks since it has several different forms such as DC batteries, AC lines, 5v or 3.3v logic levels, single-phase or three-phase circuits. Therefore, since these diverse forms have their own purposes, an adjustment is needed to match each electrical application to a particular type of source.

1.2 WHAT IS POWER ELECTRONICS?

Today, lots of electronic devices, like smartphones and tablets, are used in our daily lives, and clearly the battery of these devices has to be charged to make the device work. Moreover, our daily activities are driven by a plug or an energy source like a battery. Hence, we do not only utilize power but we rely on it. An example can be our morning routine: turn off the alarm clock, turn on the lights in your room, check the e-mails on the smartphone and so on. From an electronic point of view, a source and a load are needed during the usage of an electronic device. The source is something that generates power, for example it could be a battery or the wall power, while the load is something that consumes power, that is the device itself like a computer, TV or any other type of device. The power electronics is the technology in between them, namely the circuitry that takes power from the source and delivers it to the load to feed it, as depicted in Figure 1.1.

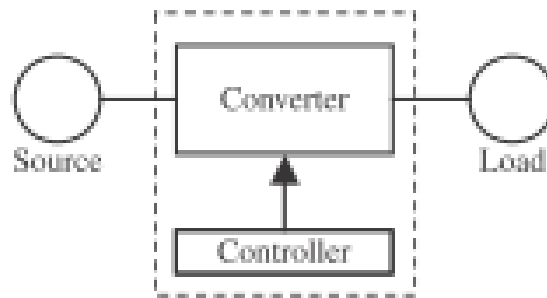

Figure 1.1: Power Electronics as interface between the source and the load.

In particular, the previous figure illustrates a power electronic system, where beyond the source and the load, there is the power converter that contains switches, lossless storage elements and magnetic transformers, while the control circuit is used to define how the switches work to reach the desired conversion, based on information given by the source, load and designer.

In other words, power electronics is the application of electronics to control the conversion of electric power where the electronic circuit takes care of changing the wall power into power that can be used from the load, makes sure that power is delivered safely to the device, so that it doesn't break or over heat.

Some examples of power electronic converters (PECs) are:

- A notebook charge: it is made of a source, that is the AC power grid and of a load that could be the laptop connected with a wire to the power pack;
- A portable battery pack, where the source is the USB power, maybe from computer, and the load is the battery pack itself, where is located the power electronic;
- A photovoltaics (PV) solar panel that feeds an AC grid. In this case, the PV solar panel is the source, while the power grid is the load. So the power electronic is in between them to convert the power from the PV panel into something that can be delivered to the power grid;
- Electric motors require appropriate voltages and currents to operate in a suitable way, ie. maintaining torque speed;
- Microcontrollers and FPGAs, common in embedded application because they support activities of washing machines, microwave ovens and automobiles, requires low voltages and high input currents.

Whereas, some examples of power electronics requirements in the light and heavy industries are:

- Industrial controls: motor and motion control applications; Power sensing and measurement; Advanced power electronic AC motor controls that should supplant almost all existing DC motor systems over the next two decades;
- Electric power industry: emergency backup power supplies; Alternative energy source conversion; HVDC transmission;
- Computer industry: need for lots of power at a different of low DC voltages; Backup power is also important;
- Electronic equipment industry: power supplies for instruments, consumer electronics, portable and remote measurement devices, and many other products;
- Automobile industry: electric actuators and energy control; Electric traction systems;

So, power electronics' framework is concerned with the conversion among different forms of electricity by designing proper circuits in order to control the flow of electrical energy. In fact, as it can be seen from the Figure 1.2, control, energy and electronics are always interrelated, and power electronics represents the median point that links all the topics together.

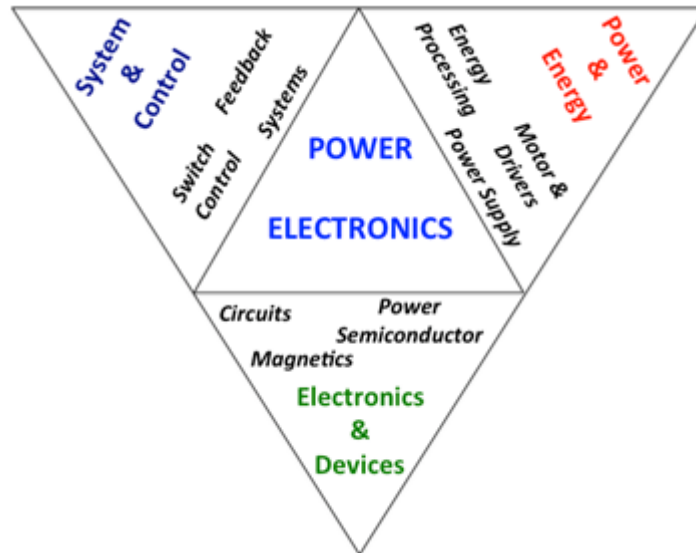

Figure 1.2: Power Electronics World

Of course, since the power converter is between the source and the load, it must only manage the flow and at the same time should not dissipate energy, otherwise the energy used by the converter is lost to the overall system. As a result, the most important features for a power converter are high input to output energy efficiency and the reliability, because a failure in the power converter means also a failure for the user (the load).

Thanks to the big developments in the field of electronics, the new power electronic components and systems allow customers to develop smaller and more energy-efficient power system that make an important contribution to reducing global energy consumption. For example, e-Mobility is one of the fastest growing markets of the future, and power electronic is used both in fast charging stations and in vehicles at the interface between the motor and the battery. In addition, it helps to control the output power of the motors of long distance and urban electric trains and supplies energy to auxiliary units such as lighting ventilation and air conditioning systems. Some of the largest application areas for power electronics can be found in industrial and commercial applications, such as motors, electric drives for robots, pumps and fans, or in the renewable energies field like photovoltaics (PV) solar panel and wind turbine. In general, the field of power electronic, can be divided in six different areas:

- Power supplies for computers (needs for lots of current at a variety of low DC voltages);
- Power semiconductor;
- Electronic motor drives (Power sensing and measurements);

- Energy processing such as power networks, high voltage-direct current (HVDC) systems;
- Electrical mobility such as electric cars and railways;
- Telecommunications field (needs power for transmission, signal processing);



Figure 1.3: Power Electronics Applications

Some years ago the process of energy conversion was not so easy as today. One of the first methods (in 1902) of high power rectification was the mercury arc rectifier, that was used to convert alternating current (AC) into direct current (DC). Thanks to this method it was possible to charge storage batteries and power DC motors for trams and subway systems. Clearly, this method was extremely expensive, inefficient and required an high cost for the maintenance of the system.

Over the time, thanks to the development of new of electronic components, new kinds of converters were invented. The first important invention was around 1950 with the bipolar junction transistor (BJT) that brought improvements in terms of stability, performance and reduced cost. Next, high power semiconductor diodes were invented and took the place of the vacuum tubes (used to control electric current between electrodes) being more efficient, smaller, cheaper, more reliable and durable. After that, with the introduction of the silicon controlled rectifier (SRC) and the increase of the switching speed of the BJTs, the range of the power electronics application started to increase rapidly. Finally, with the development of the MOSFETs in 1976 and the IGBT in 1982 the market of power electronics applications had an enormous expansion that still continues. In recent years there has been an increasing attention in the high-voltage Silicon Carbide(SiC) based semiconductor power devices and their applications such as

medium voltage drives and power converters for renewable energy integration. In the meanwhile, IGBTs and FETs have been broadly used in the application of electric motor drives, switching supplies and other power conversion systems.

Another important benefit of power electronic conversion, is that nowadays the demand for integrated monitoring of industrial facilities in order to expand safety as well as efficiency is growing. In order to meet the power demand of the new applications, features of the power semiconductor devices must be improved into support higher operating switching frequencies and current densities using new materials and manufacturing techniques. Clearly, this has an immediate impact on the dynamic performance of the devices and the increase of the temperature of operation since losses are dissipated as heat. Consequently, the design of power electronics circuits requires precise information about the junction temperature of the switches, since it determines its lifetime and reliability.

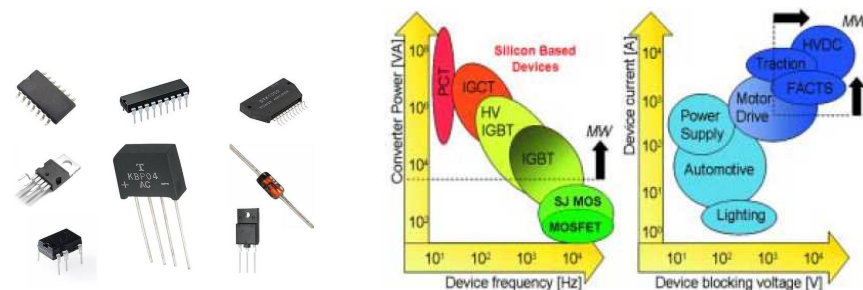

Figure 1.4: Power Semiconductor Devices and their Applications

The characteristics and the limitations of active devices, like BJT and FET, that act as a switch, are a key element in the design of power electronics systems.

In particular, an ideal switch, Figure 1.5, does not consume or dissipate any power. When the switch is closed, the current flow through the switch is equal to the current absorption by the load; the voltage across the switch terminal is equal to zero. When the switch is open, there is no current flow to the load, so the voltage across the switch is equal to the voltage source. So, an ideal switch dissipates no power. Obviously, the real behavior is different from the ideal one, but thanks to the huge advancements of the technology, semiconductor devices such as BJT and MOSFET, that are used as switches, approximate the behavior of the ideal switch, showing high efficiency and a very little amount of power wasted mainly during the switch. This is the reason for which nearly all power electronics applications are based on switching devices.

The benefits of using switching circuits are so important that it is common to associate power electronics with the study of the switching power converters. In fact, power electronics is a branch of electronics in

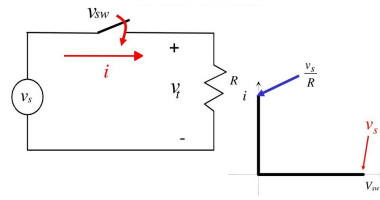

Figure 1.5: Ideal Switch: Circuit and Characteristic

which devices will be operating only in saturation and cut-off regions, unlike linear electronics in which devices will be dealing when they are in active mode. This implies that a linear device dissipates energy to control the output voltage while a power switch stays either "on" or "off" and control the output voltage with the percentage "on" V_s "off", i.e. the duty cycle of the generated waveform.

Thence, power semiconductor devices can be classified based on their switching speed. For example, diodes with a frequency up to a few kilohertz are suited for slow speed while MOSFETs and BJTs work with frequencies that go from tens of kilohertz up to a few megahertz in power applications. Devices with high switching speed, reduce the energy lost in the transitions from ON to OFF and back, but introduce also some problems with radiated electromagnetic interference (EMI).

1.3 POWER ELECTRONIC CONVERTERS AND THEIR APPLICATIONS

As explained in the previous section, power electronics had huge growth after the development of the silicon controlled rectifier (SCR), the first solid-state power switch, in 1957; in fact, today almost all of the technologies that require control of power use power electronics technology. So, with the incoming of microelectronic control, it is possible apply the modern control theory to power electronics and this makes very complex circuit functions feasible. This kind of switching technology allows power electronics systems to operate in the range from a few watts up to GW, with frequency range from some 100 Hz up to some 100 kHz, depending on the power handled. Figure 1.6 shows how electrical energy generation is distributed for the end-user, showing transmission, distribution, storage, renewable energy sources and users. As a result, the application area of power electronics is now extremely wide and is a key technology for all the following sub-systems:

- For high power level, power electronics deals with static and rotating equipment for generation, transmission, and distribution handling large amount of power;
- For consumer electronic applications, power electronics is fundamental for information processing, employing analog and digital circuits, or microprocessors including micro-controllers, digital

signal processors (DSP), and field programmable gate arrays (FPGAs).

- In the area of control, power electronics deals with stability and response characteristics in systems with feedback loops, based on classical or modern control.

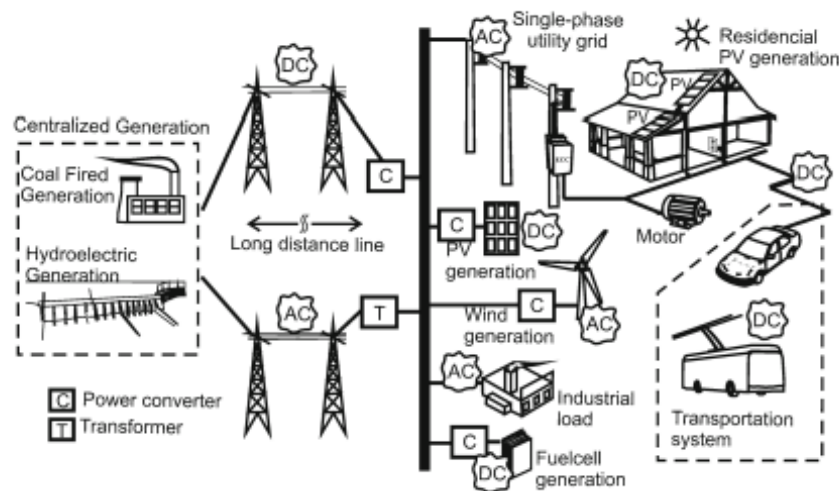

Figure 1.6: Power electronics and electrical energy generation, transmission, storage, and distribution

Thus, the introduction of devices and equipment able to convert effectively electric energy from AC to DC, DC to DC, DC to AC, and AC to AC together with the important developments in electrical power engineering has resulted in broad diffusion of power electronics in a ample spectrum of applications, such as:

- Residential: heaters, home appliances, electronic lighting, equipment sources;
- Commercial: heaters, fans, elevators, Uninterruptible Power Supply (UPS), AC and DC breakers, battery chargers;
- Industrial: pumps, blowers, robots, inductive heaters, welding, machine drive, portable sources;
- Transportation: electrical and hybrid vehicles, battery chargers, railroad electric system;
- Utility systems: high voltage direct current, generators, interface for photovoltaic, wind, fuel cells systems, Flexible AC Transmission System equipment;
- Aerospace: sources for spacecrafts, satellites, planes;
- Communication: sources, RF amplifiers, audio-amplifiers;

So, since each electronic device and application needs different voltages and has different requirements, a converter has to be used to give the right voltage level to the load. For example, as described in Section 1.2 of Chapter 1, starting from the wall AC power, a change in the voltage waveform, from AC to DC, is needed since most of the electric devices, like laptops and smartphone, require DC voltage. In general, in electrical and power engineering, power conversion is converting electric energy from one form to another such as converting between AC and DC, or changing the voltage or frequency, or some combination of these. This goal can be reached with the use of a power converter, that is an electrical or electro-mechanical device for converting electrical energy. There are four kinds of power converters, based on the input and output power:

DC CONVERSION

- DC-DC Converter (DC source, DC load)
- DC-AC Converter (DC source, AC load)

AC CONVERSION

- AC-DC Converter (AC source, DC load)
- AC-AC Converter (AC source, AC load)

1.3.1 *DC-DC Converter*

It is an electronic circuit that converts the input DC voltage, that can range from a very few watts to hundreds of MW, from one level into another based on the requirements of the load. As shown in Figure 1.7, it is made of at least two semiconductors and at least one energy storage element.

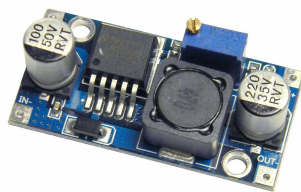

Figure 1.7: DC-DC Converter

This converter finds applications in a lot of portable devices such as computers and smartphone, which are fed with power from battery; in particular it is used to keep the voltage at a known value independently from the voltage level of the battery. They are also used in the renewable energy field, to maximize the energy collected by photovoltaic systems or by wind turbines. This kind of conversion,

common in battery-based systems and in telecommunications systems, is becoming more and more significant in a much wider range of applications, since a lot of circuits use DC power at several different voltage levels. An example is power supplies that is having great result from home appliances to industrial controllers. In the past, major part of DC power supplies obtained energy from an AC line source, modified its voltage level with a transformer and finally rectified the result. Clearly, this method was relatedly inefficient and big expensive, while today the development of power semiconductors and ICs (integrated circuits) makes it economically viable: small cheaper power supplies are built using DC-DC converters. In this kind of converter, energy is periodically stored within and released from a magnetic field in an inductor or a transformer, typically within a frequency range of 300 kHz to 10 MHz. In particular there are two main topologies, *Flyback*, when energy is stored in the magnetic field and *Forward* when energy is transferred through the magnetic field. Moreover, the most common converters are:

- Buck or Step-Down converter (Forward topology), where the output voltage is lower than the input voltage;
- Boost or Step-Up Converter (Flyback topology), where the output voltage is higher than the input voltage;
- Boost-Buck Converter (Forward topology), that is capable of converting to a higher or lower voltage;

1.3.2 DC-AC Converter

Despite a lot of our appliances are made to work with AC, small-scale power generators often generate DC. That means if you want to run something like an AC-powered device from a DC car battery in a mobile home, you need a device that will convert DC to AC. This kind of electronic device is called *inverter*. Today they have taken a prominent role in the modern technological world due to the sudden rise of electric cars and renewable energy technologies; they are also used in uninterruptible power supplies (UPS), HDVC power transmission, power grid and solar inverter. It needs a stable DC power as input in order to supply sufficient current for the designed load. The input voltage depends on the requirement of the designed device, for example 12 V DC for small battery powered consumer inverters or 400 V DC if power is from photovoltaic solar panels. Moreover, since power can be transferred both in single-phase and in three-phase, inverters can operate in single-phase or in three-phase. Single-phase inverter are used for power supplies and single-phase UPSs, while three-phase inverter are used for adjustable speed drives (ASDs) applications and for high power applications such as HVDC power transmission. Topologies for these converters can be separated into two main classes:



Figure 1.8: DC-AC Converter

1. Voltage Source Inverter (VSI): it has rigid DC source voltage that is the DC voltage has limited or zero impedance at the inverter input terminals; the independently controlled output is a voltage waveform; have practical uses in both single-phase and three-phase applications.
2. Current Source Inverter (CSI): It is supplied with a variable current from a DC source that has high impedance. The resulting current waves are not influenced by the load; this kind of inverter has practical for three-phase applications in which high-quality voltage waveforms are demanded.

As of the output waveform, an inverter can produce different waves like square wave, modified sine wave, pulsed sine wave and pulse width modulation. The output frequency is usually 50 or 60 hertz (the same as standard power line frequency), while the output voltage is regulated to be the same as the grid line voltage, that is 120 or 240 VAC.

1.3.2.1 Output waveform

A technique called pulse width modulation (PWM) is used to produce a pure sinusoidal output and it is explained more in detail in the Section 1.5. The logic of PWM is simple, it generates the DC voltage in the form of pulses of different widths, that is in regions where you need higher amplitudes it will generate pulses of larger width. The shape of the averaged pulses looks very similar to the sine curve, the finer the pulse is used the better shape the sine curve will be. To implement the PWM in an actual inverter a comparator is used. Comparators compare a sine wave with triangular waves. In the case of a pure sinusoidal output, one comparators uses a normal sine wave, while the other uses an inverted sine wave. As a result, a PWM is obtained. Moreover, to implement the averaging, that is to make it exactly sinusoidal, energy storage elements (passive filters) such as inductors (that smooth current) and capacitors (that smooth voltage) are used to smooth the power flow. If one more voltage level is introduced, it will give better approximation of the sine wave and can reduce instantaneous errors. Such multi-level inverter technology is used in high precision applications like wind turbines and electric car. To sum up, with an inverter bridge, a good PWM technique and a passive filter, the desired voltage can be produced for all the home appliances.

Generally speaking, the appliances we use in our homes (like electric heaters, incandescent lamps, kettles) that use raw power, don't care much about the shape of the wave they receive; all they want is energy and lots of it. Electronic devices, on the other hand, prefer the smoother input they get from a sine wave. This explains why inverters come in two distinct topologies:

1. *Pure Sine Wave inverters* (PSW), they use a toroidal transformer and electronic circuits to transform direct current into a smoothly varying alternating current very similar to the kind of genuine sine wave normally supplied to our homes. They can be used to power any kind of AC appliance from a DC source, including TVs, computers, video games, radios and stereos;
2. *Modified Sine Wave inverters* (MSW), use relatively inexpensive electronics (thyristors, diodes, and other simple components) to generate a kind of "rounded-off" square wave (a much rougher approximation of a sine wave) and while they're fine for delivering power to hefty electric appliances, they can and do cause problems with delicate electronics (or anything with an electronic or microprocessor controller). Also, their rounded-off square waves are delivering more power to the appliance overall than a pure sine wave (in fact there's more area under a square than a curve), so there's some risk of overheating with MSW inverters.

1.3.3 AC-DC Converter

It is an electrical device that derives DC power from an AC supply, for this reason it is also called *rectifier*. It converts alternating current, which flow changes during the transmission, into direct current, whose flow in only one direction. This kind of converters can be found in different applications such as radio, television and computer, and in high-voltage direct current power transmission systems. The output of the rectifier is firstly smoothed by an electronic filter and possibly followed by a voltage regulator to produce steady current. In particular, consumer electronics usually include an AC adapter (type of power supply) to convert mains-voltage AC current to low-voltage DC suitable for consumption by microchips while consumer voltage converters (also known as "travel converters") are used when traveling between countries that use 120 V versus 240 V AC mains power.



Figure 1.9: AC-DC Converter

Circuit that use these types of converters can be single-phase or multi-phase. In general, single-phase circuit are used for power supplies in home appliances (low power rectifiers) while three-phase circuit are used for industrial and high-power applications and for transmission of energy.

1.3.4 AC-AC Converter

It is an electronic circuit that converts the alternating current waveforms having a certain magnitude and certain frequency into another alternating current waveform of different magnitude and frequency, allowing the control of the voltage, frequency, and phase of the waveform applied to a load from a supplied AC system. Even if it is not common in home appliances like the converters described above, this kind of conversion is principally necessary for speed controlling of machines, for low frequency and variable voltage magnitude applications. Hence, for example, by adjusting AC voltage using the AC to AC converter it is possible to regulate the speed of induction motors.

There are different kinds of AC to AC converters:

- Cycloconverters (also called *frequency changers*), are used in high power applications driving induction and synchronous motors.



Figure 1.10: AC-AC Converter

They are usually phase-controlled and they traditionally use thyristors due to their ease of phase commutation. Moreover in a cycloconverter, unlike other converters, there are no storage devices like inductors or capacitors. For this reason, the instantaneous input and output power are equal. In general, they are preferred for avoiding DC conversion and to limitate the number of stages like AC to DC to AC, since they are expensive and cause more losses. Some applications of cycloconverter are: cement mill drives, rolling mill drives and winders.

- DC link based AC to AC converter (aka AC/DC/AC converter), make use of a DC link, that is a rectifier is used to convert AC to DC and then an inverter is used to get AC from DC. As a result, an output with a different voltage and variable (higher or lower) frequency is obtained. Due to their wide area of application, these converters are the most common contemporary solution. Moreover they are stable in overload and no-load conditions as well as they can be disengaged from a load without damage.
- Matrix converters, the newer form of cycloconversion. This method removes the storage element in the DC-link, at the cost of a larger number of semiconductors. Matrix converters are often seen as a future concept for variable speed drives technology, but in spite of deep research over the decades they are not popular yet in the industrial market.

1.3.5 Voltage Regulator and Power Supply

Voltage regulators or stabilizers are used in home appliances, like computer power supplies where they stabilize the DC voltages used by the processor and other components, to compensate for voltage fluctuations in mains power, i.e. in order to protect them from fluctuating input voltage. In this way, they hold up a constant AC or DC voltage that is independent of the load properties. There exist different techniques to stabilize AC voltage like electromechanical regulator and PWM static voltage regulator. This is the newest technique, and provides real time control of voltage variation, while to stabilize the voltage DC power supplies either series or shunt regulators are used.

Power supplies are used in different range of application being a basic component of several electronic devices:

- Aircraft power supply: Both commercial and military avionic systems require a DC-DC power supply to convert energy into usable voltage;
- Electric Vehicle power supply: a power supply is needed to convert the high voltage coming from vehicle battery power;
- Computer power supply: it is a SMPS that converts the power from the mains supply to the several DC voltages needed internally. In particular, for their high efficiency (more than 90%), these converters are useful for task like convert a computer's main supply voltage (usually 12 V) down to the lower voltages needed by electronic components such as CPU or RAM, which need voltages on the order of 1.8 V or less;

Based on the voltage regulator used, power supplies can be broadly divided in two main types:

1. *Linear regulated power supplies*, based on devices that operate in their linear region and process the input power directly; they act as a variable resistance causing a voltage drop.
2. *Switching regulated power supplies*, based on a device forced to act as an on/off switch, that is providing output voltage by switching ideally lossless elements.

Both of them have some advantages depending on the applications and its requirements. For example, linear regulator are suitable if low EMI (Electromagnetic interference) and low noise are required; moreover at low drop level they are cheaper and occupy less PCB space, while switching regulator are suitable if power efficiency is critical or if the only power supply is a low DC voltage and a higher output voltage is required. It is true that the most important advantage of a SMPS is their efficiency, that is much higher than the efficiency of a linear power supply, since they dissipate a very little amount of power switching their output to keep the L/C output section at the correct voltage.

1.3.5.1 *Linear regulated power supplies*

Linear power supplies, in order to produce the desired voltage, continually dissipate excess power in ohmic loss like a resistor, in the form of heat. In fact, they gain their name from the fact that they use linear, i.e. non-switching techniques to regulate the voltage output from the power supply. The main elements of linear power supply are:

- Input transformer (that determine size and weight of the device): As many power supplies get their source power from an AC mains input, it is common for linear power supplies to have a step down transformer to get lower voltage. This also serves to isolate the power supply from the mains input for safety.
- Rectifier: As the input from an AC supply is alternating, this needs to be converted to a DC format.
- Smoothing: Once rectified from an AC signal, the DC waveform needs to be smoothed to remove the varying voltage level, so large capacitors are used.
- Linear regulator: The smoothed supply is applied to the linear regulator, that provides a properly regulated output, since each load has different voltage requirement.

These devices are largely used since they offer a lot of benefits in terms of overall performance, and are especially used when the line regulation and removal of noise, coming from the AC line, is extremely important. So, even if it may not be as efficient as SMPS, often audio amplifiers and many other items of electronic equipment use linear power supplies to obtain the best performance.

Advantages

- Low noise due to the use of the linear technology;
- No complexity: simpler circuit and simpler feedback loop stability criteria;
- Low risk of equipment damage;

Disadvantages

- Low efficiency, on the order of 30-40%.
- Size and weight: These devices result large and heavy due to the use of the input transformer and the capacitors;
- Losses in the regulator and the transformer;

1.3.5.2 *Switching regulated power supplies*

In these devices the input power is converted to pulses before processing, by components that operate predominantly in non-linear modes (i.e. transistors that spend most of their time in cut-off or saturation). More in detail, the AC mains input is directly rectified and then filtered to obtain a DC voltage. The resulting DC voltage is then switched on and off at a high frequency by electronic switching circuitry, thus producing a sums of pulses that will pass through a high-frequency transformer or inductor and a capacitor. Switching occurs at a very

high frequency (typically 10 kHz — 1 MHz), thereby enabling the use of transformers and filter capacitors that are smaller, lighter, and less expensive than those found in linear power supplies operating at mains frequency. After the inductor or secondary transformer, the high frequency AC is rectified and filtered to produce the DC output voltage. In particular, to keep the output voltage constant, the power supply employs a feedback controller that monitors current drawn by the load. The duty cycle of the switch determines how much charge is transferred to the load, and it increases as power output requirements increase. The output current flow depends on the input power signal, the storage elements and circuit topologies used, and also on the pattern used (i.e. PWM with an adjustable duty cycle) to drive the switching elements. Moreover, if a SMPS uses an adequately insulated high-frequency transformer, the output will be electrically isolated from the mains; it is an essential feature for safety.

Advantages

- Reduced losses thanks to the use of a transformer operating at high frequencies;
- Smaller and lighter than a linear regulator;
- High efficiency: In the range of 70-90%, in fact almost all the power is transmitted to the load thanks to the little amount of wasted power;

Disadvantages

- Greater complexity: They consist of an integrated controller, one or more power transistors and diodes as well as a power transformer, inductors and filter capacitors;
- Electromagnetic interference (EMI), due to the high switching frequency ;

1.4 POWER ELECTRONIC CONVERTERS FOR ELECTRIC MOTOR DRIVES

The primitive electric motors, since their first appearance (1886) more than a century ago with the American scientist Frank J. Sprague, have gone through a process of continuous evolution to achieve the goals of cost, size, and performance, and this evolution will continue into the future. All electric motors are governed by the laws of electromagnetism and are undergo to the same constraints forced by the materials (copper and iron) from which they are made. In particular, an electric motor is a device that converts electrical energy into mechanical energy, acting as a workhorse in a variable-speed drive system. Generally, an electric motor can be powered by direct current or by alternating current which leads to the two main classifications: AC motors and DC motors. Traditionally, AC machines, particularly induction motors, have been used in constant-speed applications, while DC machines were used in variable-speed applications. Furthermore, based on the two main classification there are multiple varieties of electric motor differentiated by structure and signal type., as depicted in Figure 1.11. Actually AC motors can be further classified in synchronous and asyn-

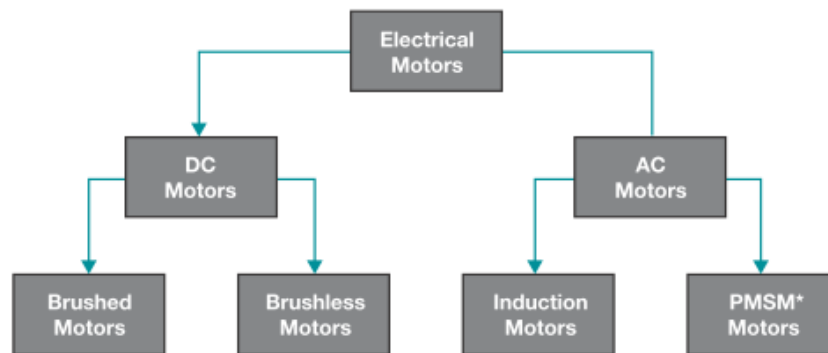

Figure 1.11: Motor Classification

chronous motors, that is whether or not the rotor runs at the same frequency as the stator.

In particular, the motor that we have used in this work is a *brushless DC motor*, depicted in Figure 1.13 and Figure 1.14, a synchronous motor powered by DC electricity with a SMPS which produces an AC electric current to drive each phase of the motor via a closed loop controller. For this reason only the brushless DC motor will be described in detail in the following; for reference a comparison between different motors is represented in Figure 1.12, showing the use of motors in terms of voltage and power levels, along with the pros and cons of each.

Motor Type	Voltage Levels	Power Levels	Applications	Advantages	Disadvantages
Brushed DC	<100V	<100W	Toys, coffee machine, gate openers, etc.	Easy to spin, low cost	Brushes wear out, Inefficient
Brushless DC	<600V	Up to a few kW	Household appliances, white goods, pumps	Long life/reliable, high efficiency	Cost, complicated control
AC induction	>600V	>750 W	Industrial and factory automation	Low cost, less maintenance, rugged, reliable in wide power range	Starting issues, low-power factor correction, complicated speed control

Figure 1.12: Comparative analysis of motors

1.4.1 *Brushless DC Motor*

The expansion of solid state power semiconductor electronics in the 1970s enabled the commutator and brushes to be removed in DC motors and the consequent growth of brushless motors. Today brushed motors are only used in low power applications or where only DC is available. The reasons that have brought to the elimination of the commutator and the decline of brushed motors are different:

- The friction of the brushes sliding along the rotating commutator segments causes torque losses that can be significant in a low power motor.
- The repeated abrupt switching of the current through the inductance of the windings causes sparks at the commutator contacts. These are a fire hazard in explosive atmospheres and can cause electromagnetic interference in nearby microelectronic circuits.
- Maintenance of the brushes;

Hence, thanks the advancement in the semiconductor technology, an electronic servo system replaces the mechanical commutator contacts, detecting the angle of the rotor, and accordingly controls semiconductor switches. The disposal of the sliding contact allows brushless motors to have less friction and longer life, making that their working life is only limited by the lifetime of their bearings. The BLDC motor is largely used in applications such as computer peripherals (disk drives, printers), appliances, automotive, aerospace, medical and automated industrial equipment. Since it is electrically commutated by power switches instead of brushes, it offers many advantages over traditional brushed DC and AC motors, such as:

- Smaller and lighter
- Lower materials costs
- Lower EMI
- Higher efficiency and reliability, largely due to the frequency at which the electricity is switched determined by the position sensor feedback

- Higher speed range
- Longer life
- Better speed versus torque characteristics

Another important advantage is that BLDC motor commutation can be implemented in software using a micro-controller or in digital firmware using an FPGA. In this way, as can be seen in our work, controller software can be customized to the specific motor being used in the application, resulting in greater efficiency.

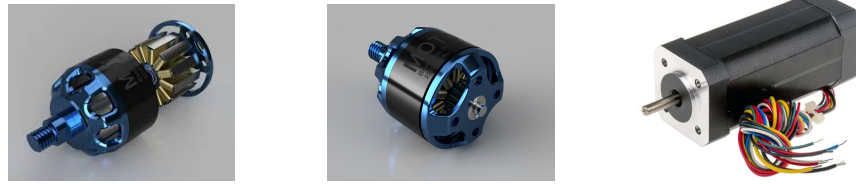

Figure 1.13: Brushless DC motors

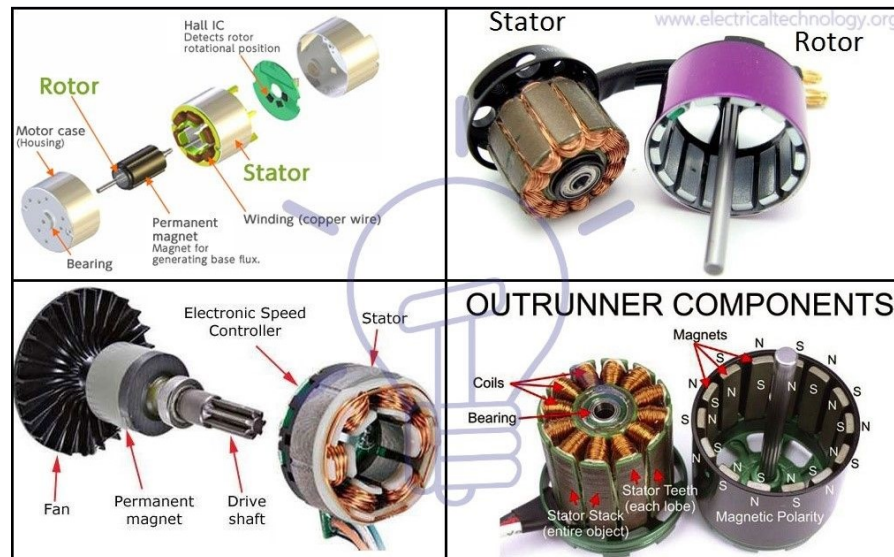

Figure 1.14: Construction of Brushless DC motor

However, since brushless motors do not self commutate, torque control, which is fundamental to the successful operation of any servo system, presents a more complex challenge. Several techniques have developed for controlling torque in brushless motors in order to produce the maximum torque, like sinewave control and Field Oriented Control (or Vector Control).

In particular, in this thesis a determinate application of BLDC motors has been analyzed, namely *Motion Control System*. Brushless DC motors are largely used in the industry, above all for motion control, actuation system and positioning thanks to the advantages above described. The most popular applications of BLDC motors in industrial engineering

are linear motors, servomotors for machine tool servo drives, actuators drive motors for industrial robots.

To sum up, in the course of the last two decades the field of controlled electrical drives had spread fast thanks principally to the advances of semiconductors in power and signal electronics. In particular, these advancements have allowed the growth of motor drive control with ever lower power dissipation and ever more accurate control structures, that is not only are the DC current and voltage controlled but also the three phase currents and voltages are managed with vector controls. Thanks to this kind of control, the AC machine obtains each benefit of the DC machine and frees itself from the mechanical commutation disadvantages, achieving a very accurate steady state and transient control and leading to high dynamic performance in terms of response times and power conversion.

Everyday we see systems in motion all around us. What actually drives these movements are motors. Additionally, most household appliances such as refrigerators, air-conditioners, ventilation fans, washers, driers and so many others all require electric motors: the goal of this section is to discuss the role of power electronics in the motor drives of the applications that we use and encounter in household and industrial environments.

1.4.2 *Motor Control Overview*

Motor control demands three fundamental elements: a motor, a drive, and one or more feedback devices. The drive regulates current (in order to produce torque), knowing velocity and position. In nearly all control systems, multiple axes of motion must be controlled in synchronization. Usually a separate multi-axis controller provides coordination for the machine while the drives are left to implement the control associated with individual motors, but sometimes the application is so well defined that the drive and controller are integrated into one device, like a computer hard-disk controller. In brushless motors the torque command and the motor position are used to calculate multiple current commands in a process called commutation, whereas for brush motors, commutation is mechanical. As described formerly, motion control systems are among the most used in BLDC motors, such as pumps and fans. Additionally, they can be comfortably automated for remote control. The reason why brushless motors are preferred over stepper motors is that they are based upon a closed loop control system that produces closely controlled and stable operation, while DC stepper motors, for example, work with open loop control exhibiting torque pulsations.

1.4.2.1 What is a drive?

An electric motor can be seen as a device that moves energy from an electrical source to a mechanical load. The system in which the motor is situated and makes it rotate is called the *drive*, and is shown in the Figure 1.15. The task of the motor drive is to get electrical energy from the source and provide electrical energy to the motor, such that the wanted mechanical output (speed of the motor, torque and the position of the motor shaft) is reached. Power converter have different

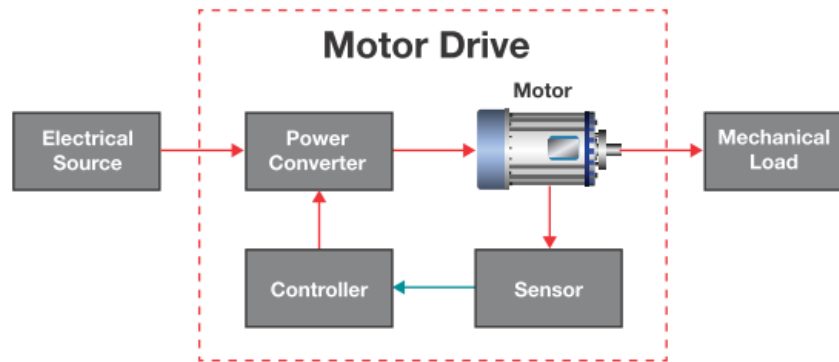

Figure 1.15: Block diagram of a motor drive system

tasks in the motor drive, such as:

- Transfer electrical energy from a source that could be of a given voltage, current at a certain frequency and phase as the input, to an electrical output of desired voltage, current, frequency and phase to the motor such that the required mechanical output of the motor is achieved to drive the load;
- Controller adjusts energy flow through feedback coming from the sensor block;
- Controller tells the converter what it needs to be doing. This is a closed-loop feedback system, that is the method of comparing what is actually happening to what the motor should be outputting, then adjusting the output accordingly to maintain the target output;

Enhancing the efficiency of systems motor-drive based could possibly come out in an important decrease in global electricity consumption, in fact a lot of researches show that electric motors represent about 50% of the whole electrical energy consumption across all applications. So, with the increasing demand of electricity due to the industrialization and urbanization across the world, the capability to provide energy is becoming even more challenging. The goal is to reduce energy consumption and carbon emissions on the environment by using an efficient power converter, that as it has explained in the previous

sections, consist in the use of switched-mode power supplies (SMPS) that yields 100% efficiency in an ideal situation.

1.4.2.2 *What is a servo system?*

Nowadays, electronic motion control is a multi-billion-dollar industry. Servo motion is a fraction of that industry, sharing it with non-servo motion, such as stepper motors and variable-frequency systems. A servo system is defined as the drive, motor, and feedback device that enable accurate control of position, velocity, or torque using feedback loops.

However, the lack of a separate feedback device does not mean the system is not a servo. This is because the feedback device may be present but may not be easily identified. For example, head-positioning servos of a hard-disk drive use feedback signals built into the disk platter rather than a separate feedback sensor; in addition, some applications use electrical signals from the motor itself to indicate speed. So, a servo motor is a sort of all-in-one device that has an electric motor, any integrated circuits required and a potentiometer included on the device.

Even if also stepper motors permit accurate regulation of motion, they are not servos, being based on "open-loop" systems without the need for stability analysis. One of the most important properties is the capacity to regulate position with fast response to changing commands and noise. Applications based on servo motor, generally cycle a motor from one position to another at high rates. However, there exist also servo applications that do not need fast acceleration, such as web-handling applications, which process rolled material such as tape, do not command large accelerations during normal operation.

1.5 A METHOD TO CONTROL A BRUSHLESS DC MOTOR: PULSE WIDTH MODULATION

In order to understand the behavior of PWM, we need to understand how switching devices are represented in mathematics. To analyze the behavior of switching devices the Fourier Series of a switching functions is used, in fact through Fourier analysis, we can resolve periodic signals into individual frequency components. Since whatever switching function $q(t)$ is either 0 or 1, and is generally periodic, a plot of a given $q(t)$ will be a train of square pulses of arbitrary period T , as depicted in Figure 1.16.

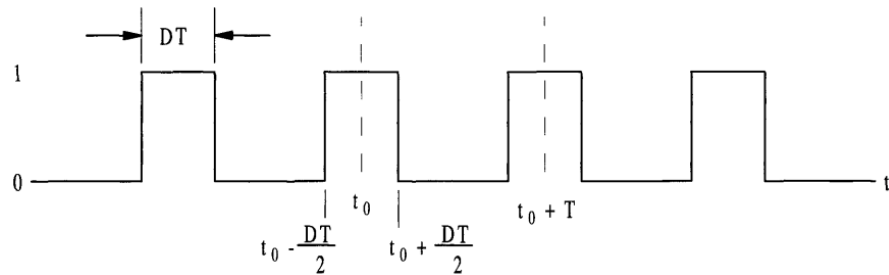

Figure 1.16: A periodic pulse train

As can be seen, the pulse is centered on the time $t = t_0$. Each pulses in the train have duration DT and indicates a measure of the actual ON time, where D is defined as the *Duty Cycle*, with $0 \leq D \leq 1$. Duty cycle is a fraction of the period in which the system is working, where the period is the time it spends for a pulse to complete an ON and OFF cycle. Generally, it is expressed as a percentage, so the formula is:

$$D = \frac{DT}{T} * 100\% \tag{1.1}$$

For example, as can be observed from the Figure 1.17, the first pulse has a duty cycle equal to 50%, in fact it remains high for 1/2 of

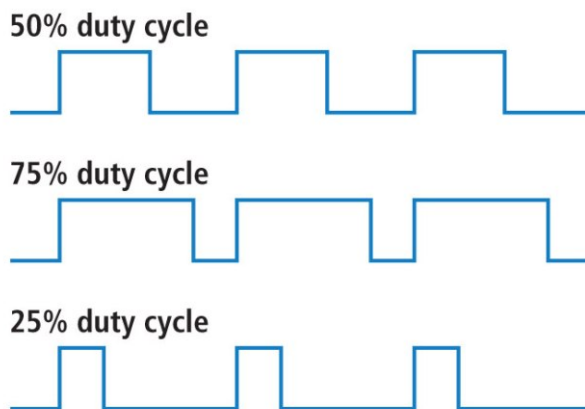

Figure 1.17: Three pulses with different Duty Cycle

the period or low for $1/2$ of the period; the second one has a duty cycle equal to 75%, in fact the signal is on for $3/4$ of the total period, while in the third one duty cycle is equal to 25%. It is widely used in electrical and electronics applications to describe the percent time of an active pulse in devices like SMPS, and in biological system as well, to describe the activity of neurons and muscle fibers. Besides duty cycle, a generic pulses is also described by the frequency $f = \frac{1}{T}$ and the radian frequency $\omega = \frac{2\pi}{T}$. In particular, the Fourier components of $q(t)$ are:

- $a_0 = D$, it means that the DC component is equal to the duty cycle
- $c_n = \frac{2}{\pi} \frac{\sin(n\pi D)}{n}$, $n \neq 0$
- $\theta_n = -n\omega t_0$

So, the Fourier Series for a general $q(t)$ can be written as

$$q(t) = D + \frac{2}{\pi} \sum_{n=1}^{+\infty} \frac{\sin(n\pi D)}{n} \cos(n\omega t - n\phi_0) \quad (1.2)$$

The Fourier representation in 1.2 shows that the function $q(t)$ is determined entirely by just three parameters: duty cycle D , radian frequency $\omega = 2\pi f$, and the reference time t_0 that fully define the switching function. Hence, switch action can always be interpreted in terms of one or more of the them, in particular:

- *Duty Cycle adjustment*: The duty cycle is related to the pulse width DT . Converters that operate by regulating the duty cycle of their switches exhibit PWM action;
- *Frequency adjustment*: It is unusual in power electronics for a very basic reason, that is places tight constraints on the switching frequencies due to the need to provide matching frequency components of voltage and current in a given source or load;
- *Timing adjustment*: It is one of the oldest methods to change the behavior of a power converter;

Today PWM and phase control are the most common adjustment techniques in power electronics. In this thesis a PWM technique and the duty cycle have been used to control our DC brushless motor.

1.5.1 Pulse Width Modulation

In the past, one of the method to control the power delivered to the load was the use of a large variable resistor (rheostat) in series with the motor. Clearly, this method was extremely feckless, since it generates a lot of heat and wasted power in the resistance. So new methods, more efficient, low cost and more compact in order to drive motors for fans, pump and robotic servos were needed. PWM emerged as a solution for this complex problem. Pulse width modulation is an analog modulation technique, like PAM and PPM, used to encode a message into a pulsing (carrier) signal. Despite the type of carrier being always the same in all the three modulations, that is a train of pulses, the parameter that changes in the three modulations is different, in fact in the PWM changes the width, in the PAM changes the amplitude and in the PPM changes the position. PWM is a well-established method of controlling the amplitude and the frequency, and improving the waveform of the basic square-wave voltage at the output of an inverter operating from a fixed DC supply. The most used techniques for realize such a modulation are the subharmonic techniques. According to these, the widths result from an electronic comparison of correctly shaped and controlled analog signals, that is a triangular carrier of fixed frequency and amplitude is compared with a sinusoidal reference of frequency and amplitude less than the triangle (Figure 1.18).

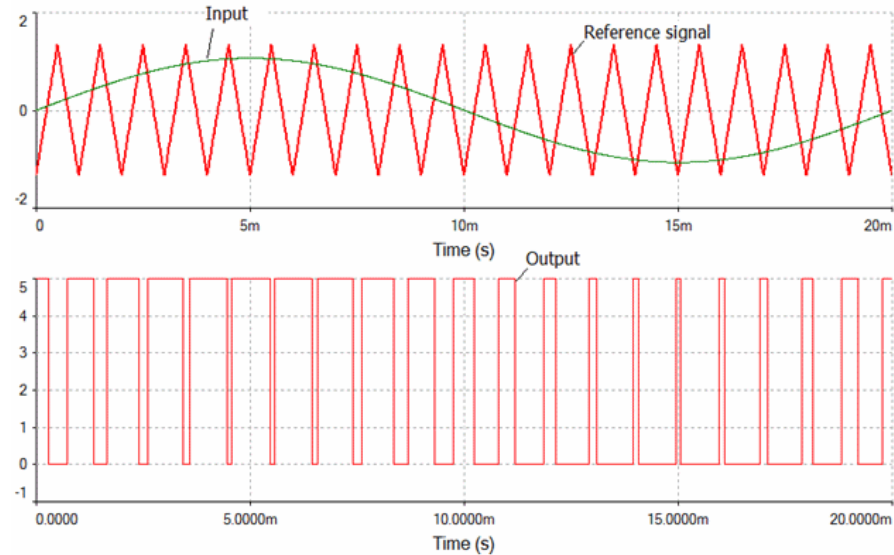

Figure 1.18: Pulse Width Modulation technique

In other words, it is a method for producing an analog signal with the use of a digital source. The behavior of a PWM signal is determined by two main elements: duty cycle and the frequency that defines how fast the PWM finish a cycle, i.e. how fast it switches between high and low states. PWM switching frequency has to be faster, in fact since

the average value of voltage supplied to the load is regulated by the switch position and duration of its state, if the ON period of the switch is longer compared to its OFF period, the load receives comparatively higher power. Moreover, it depends on load and application such as 120 Hz in a lamp dimmer or between a few kHz and tens of kHz for a motor drive. The main advantage of PWM is that power loss in the switching devices is very low. When a switch is off there is practically no current, and when it is on and power is being transferred to the load, there is almost no voltage drop across the switch. Power loss, being the product of voltage and current, is thus in both cases close to zero. In addition, PWM has an high noise immunity and it is very easy from the point of view of complexity of generation and detection.

In other words, PWM technique consists in the generation, through ON/OFF control on the semiconductor switching components, on the output port of a series of pulses with the same amplitude and different width. The duty cycle of the output waveform needs to be modulated by a determined rule and as a result both the output voltage and output frequency of the inverter can be regulated.

For all the reasons above, PWM technique is used for a large kind of control applications, but although can be used in communication systems to convey information over a communications channel, its main use is to allow the control of the power supplied to electrical devices, especially motors. PWM started to be used in motor control since 1960 with the development of the semiconductor devices like MOSFET and BJT. It is the preferred approach to adjusting motor speed for two main reasons: it is energy efficient because it doesn't generate additional heat and improves fan reliability because the fan doesn't run at full speed all the time. It can also be used to control valves, pumps, hydraulics, and other mechanical parts.

In addition, PWM can be used also in brightness control in smart lighting systems by controlling voltage to LED driver connected with LED bulbs or in photovoltaic solar battery chargers. The frequency of a PWM signal depends on the application and the response time of the system that is being power. For example:

- Heating elements or systems with slow response times: 10-100 Hz or higher
- DC electric motors: 5-10 kHz or higher
- Power supplies or audio amplifiers: 20-200 kHz or higher

FIBER-POWER: APPLICATION OF OPTIC FIBERS TO POWER ELECTRONICS

As described in Chapter 1, over the past few decades power electronics have had important progress thanks to the development of more powerful microprocessor and the consequent decreasing cost. These developments lead digital control to become the enabling technology for many engineering fields and power electronics to be used in several applications, ranging from computer power supplies and telecommunications to the hybrid electric vehicles and motor drive control.

In this Chapter the basis and the goals of our work are presented. First of all, the State of the Art of power electronics about motor drive control is analyzed, describing methods for centralized and distributed control, with their benefits and drawbacks in motion control system. After that, the most important communication topologies are introduced and also an overview of the major communication protocols used in power electronics are briefly explained. Next, an introduction about our work is given. In particular, the goals and the stimulus are described, making use of an example of the application of optical fiber to the power electronics. Finally, a background about optical communication is presented, focusing our attention on the benefits of the plastic optical fiber over the glass optical fibers and also describing the State of the Art of plastic optical fiber.

2.1 POWER ELECTRONICS CONTROL ARCHITECTURE

Power electronics applications in high power systems are generally large and expensive. Moreover these applications are normally complex and have several functions. Because of these characteristics, development and implementation of a control algorithm is not so easy. Hence, a new kind of approach is needed in order to prevent customized solutions to each applications. This method consist in the modularization of power electronics system, but despite the use of modularized power stages is largely spread, the major part of power electronics devices rely on a centralized digital controller [11] and have several drawbacks [12], making the device poor in terms of flexibility and re-usability and at the same time increasing the cost. Moreover, until a few years ago, power electronics devices were characterized by having complicated maintenance, lack of standardization and high cost, that decreased for a while possibilities for wider spread of power converters.

In order to overcome these problems, new power electronics devices were developed having some uppermost features, such as:

- in-circuit programmability, to allow for simple software and hardware reconfiguration and use of one standardized module in different applications;
- a high level of integration, to improve reliability and lower costs;
- flexibility, in order to obtain adaptability and multi-functionality;
- dedicated distributed control scheme;

2.1.1 *Design of PEBB based Power Electronics Systems*

For these reasons, during the last two decades, a lot of research and efforts on an integrated systems approach in the design of power electronics components has been done, taking the name of Power Electronics Building Block (PEBB), developed by the Office of Naval Research (ONR). As explained in the document prepared by the Power Electronics Subcommittee of the IEEE PES Substations Committee:

"Power Electronics Building Block (PEBB) is a broad concept that incorporates the progressive integration of power devices, gate drives, and other components into building blocks, with clearly defined functionality, that provides interface capabilities able to serve multiple applications. This building block approach results in reduced cost, losses, weight, size, and engineering effort for the application and maintenance of power electronics systems. Based on the functional specifications of PEBB and the performance requirements of the intended applications, the PEBB designer addresses the details of device stresses, stray inductances, switching speed, losses, thermal management, protection, measurements of required variables, control interfaces, and potential integration issues at all levels."

The use of PEBBs in order to develop new power electronics systems ranging from kW to thousands of MW that can be adopted in several applications would come out in high-volume manufacturing potential, decreased engineering effort, decreased design testing, on-site installation and lower maintenance effort. So, the main scope of PEBB is to develop set of multi-functional and easy-to-use power electronics modules able of working in a vast range of applications [16]. In this way, blocks for power electronic systems are standardized and modularized, becoming plug and play modules operate in collaboration with each other, in different combinations proper for different applications [18]. Nevertheless the important advancements in the integration and modularization in switching power converters, the

control architecture of power electronics devices has not got the same advancements, in fact most of controller have an architecture heavily dependent on converter topology and the application [11].

Thus, the control architecture represent one of the most important aspect in the development of a flexible and multi-functional PEBB. Several work has already been done about the control and communication by using a distributed controller scheme. In their works, Toit et al. [19] have presented a distributed control scheme in which each phase leg is regulated by a different controller. Then, data are exchanged between the controller and the phase legs through the *daisy-chained* fiber optical link. Malapelle et al. [20] proposed a distributed control scheme for high power drives, dividing the controller on a regulator (dedicated for motor control), and a bridge controller linked with a slow parallel bus. Bassi et al. [21] proposed new methods for communication in electrical drives.

So in this thesis, instead of using a centralized approach in order to control a power converter, we have taken advantages of distributed control scheme that split and distribute control between power stage, the application controller and the communication link, relying our work on the great number of research about motion control systems, in fact it is well established in motion control applications and factory automation systems.

2.1.2 *Distributed digital controller in motion control system*

Electric motors are omnipresent in industrial applications. Every kind of motor, DC, AC or special like stepper motor or brushless DC motor, have a fundamental role in the working of motorized machines in industrial environments. Each motor system has a motor drive subsystem that include a lot of components like optocouplers, rotary and motion control encoders, that need to be regulated in the more suitable way. One of the most important goal of designing a new motor drive is to drive more current while delivering high efficiency, reliability and accuracy with optimal high voltage protection, since improving efficiency of industrial motor drive would substantially reduce industrial electricity consumption. To reach these goals, high reliability optocouplers and fiber optic solutions are essential to long term operation and availability of industrial motors, in fact in a typical industrial motor drive operation, an important amount of power is lost in the inverter stage due to inefficiency in the MOSFET switching.

Accordingly, a distributed control approach is much more need. A typical application that could benefit from the distributed control scheme is those presented in [22], in which a PEBB design with a centralized control is described. In particular, three-phase static variable compensator is made of 12 building blocks, each having 16 power switches

regulated by a controller consisting of a digital signal processor (DSP), five FPGAs and a fiber optic board. The direct control of 192 power switches and feedback data demand a great amount of cabling (≈ 2 km) and a very powerful controller. So, one of the most important reasons is definitely the wiring that result bulky and harmful for the whole power electronic system, increasing the cost e decreasing the performance.

Despite exist various topologies of physical implementation of three-phase converters, certain common denominators are shared. As explained in [12] by Celanovic et. al, the idea is to split, on a phase-leg basis, the common power electronics converters shown in Figure 2.1, using an open, flexible and high-bandwidth communication link that will give to the system farther level of flexibility and adaptability.

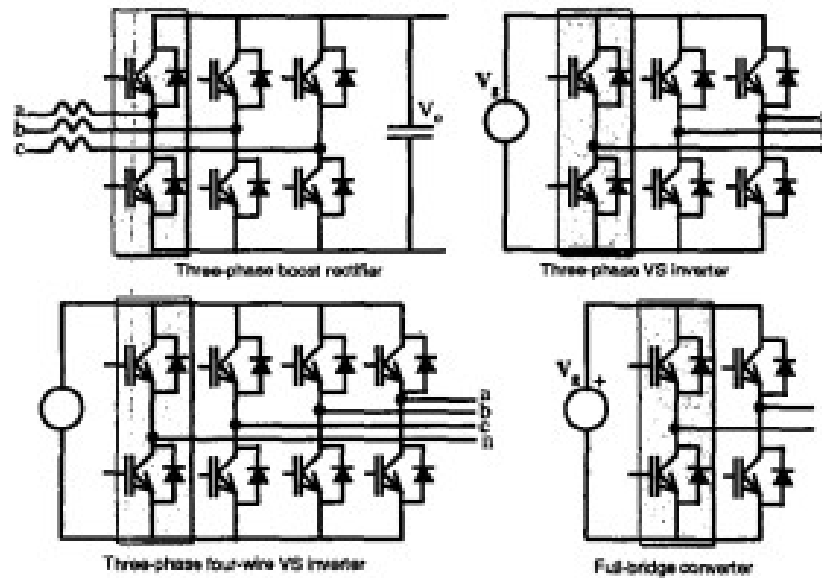

Figure 2.1: Common converter topologies, (Celanovic 2000)

Then, by adding the common switching cell, gate drivers sensor and some local intelligence, a universal, smart and modular power conversion building block can be realized. So, the two main parts (switching module and application manager) can be divided by using a suitable interface.

As can be seen in Figure 2.2, the system architecture is made of three main components:

- an application manager (main controller)
- a communication link
- a power processing units

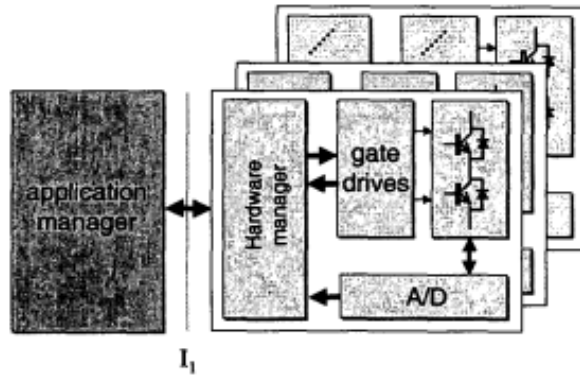

Figure 2.2: New system architecture, (Celanovic 2000)

Let's see more in detail these three main components.

2.1.2.1 Application Manager

This block supply system flexibility and software reconfigurability since it is free from any type of low-level hardware oriented tasks. In fact, it is specially developed to execute higher-level control algorithm and supervisory tasks. In general, as depicted in Figure 2.3, it is composed by a processor, PLD and serial I/O ports. Moreover, being its structure completely independent of the converter topology, number of switches and sensors, it has also the capacity to regulate multiple independent power electronics modules.

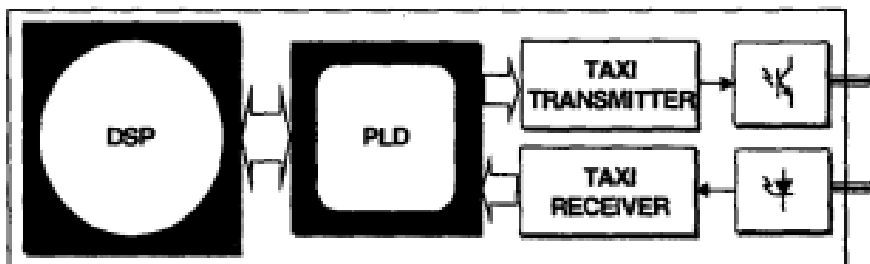

Figure 2.3: Application Manager, (Celanovic 2000)

2.1.2.2 *Hardware Manager*

This block is internal to the power electronic device and manage a lot of important functions, like:

- Low level module protection;
- Communication and sensing of all key analog variables;
- PWM generation;

It is independent of the application and can be developed for different power converter topologies (i.e. for a single phase-leg or for a three phase converter), depending on the power level and the system requirements.

2.1.2.3 *Communication Link*

In this kind of architecture, the communication link has a very important role, since it is responsible of a reliable, inexpensive and fast control structure. Clearly, we would like to have the maximum amount of information on the channel because the more is the information the more flexible will be the system, but since the bandwidth of the communication link is limited, a compromise has to be set. In general, two basic kind of information that are exchanged on the network are:

1. the desired duty cycle and switching period that coming from the application manager to the hardware manager;
2. the feedback data that are sent from the hardware manager to the application manager in the form of voltage, temperature and status information;

So the processor computes duty cycles based on received current and voltages values and then give them to a programmable logic device (PLD), located on a controller board next to it, that generates PWM pulses and sends them individually to each of the switches.

2.2 COMMUNICATION TOPOLOGIES

Today's new topologies that better use digital control are emerging. Recently, as described in [19], converters are based on modularization and have daisy-chained phase legs, that is a sort of ring structure. In this way, costs are reduced and more complicated transmission media can be used. Despite this kind of topology have a lot of advantages, it brings also some problems related to the delay accumulated in the network.

In general, when a power electronic system has to be developed, a communication topology has to be chosen for the network nodes. The main used topologies are star, bus, ring and daisy-chain. The choice is based on different parameters such as the number of nodes, environmental conditions and the available hardware.



Parameters	Topologies			
	Star	Bus	Ring	Daisy chain
Master-slave configuration				
Number of I/O's required at the master	Increases with increase in number of slaves	Fixed for any number of slaves	Fixed for any number of slaves	Fixed for any number of slaves
Impact of modifying the structure	Adding new slaves requires installation of additional hardware and I/O pins at the master	Adding or removing slaves is easy but needs to consider the termination of the trunk	Adding or removing slaves is easy	Adding or removing slaves is easy. Hot connect is possible
Communication protocol requirements	Simple protocol with high throughput	Complex protocol with high throughput, low jitter and synchronization	Complex protocol with need for high throughput, synchronization and low jitter	Complex protocol with need for high throughput, synchronization and low jitter
Point of failure	Master	Master or the trunk	Any slave	Any slave
Reliability and redundancy	Failure of one slave does not affect the whole network. Due to complex hardware signal integrity issues at master	Failure of one slave does not affect the whole network.	Failure of one slave can affect the whole network. Option of dual ring gives a redundant system that can tolerate failure of one slave	Failure of one slave can affect the whole network.
Hardware and wiring simplicity	Hardware and wiring, complex at the master	Hardware and wiring, simple master and slave	Hardware and wiring, simple and same master and slave	Hardware and wiring, simple and same master and slave

Figure 2.4: Communication topologies: Structure and features, (Vaidya 2017)

2.2.1 Star Structure

This topology, as shown in Figure 2.4, has the nodes directly linked to the central node, by means a point-to-point bus lines used for sending one signal in one direction, so when a PWM signal is generated by the controller, it is sent to each of the regulated switches by means the bus lines. Despite being the simplest topology and having an easy communication protocol, it limits the maximum number of PEBB that can be linked to the master controller. More, it needs complex wiring. In fact the number of the lines is at least equal to the number of power modules, and in case of uni-directional communications, the number of lines double respect to the number of power modules. Another important drawback is related to the link between each of the module. This implies that a port at the controller board is needed to act as an interface to each of the modules. So, in the case that the number of nodes have to be modified, a new controller interface has to be designed, meaning that the controller interface reliant on converter topology.

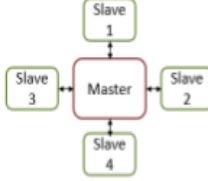
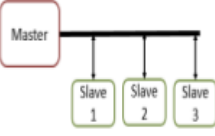
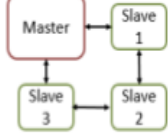
2.2.2 *Bus Structure*

In this topology, shown in Figure 2.4, there is a common bus shared by all the devices linked to the master. Clearly, adding a new device with this topology is very simple, making it scalable and flexible, but it is also true that it requires a complex communication protocol.

2.2.3 *Ring Structure*

This topology, shown in Figure 2.4, is extremely simple and low-cost. Nodes are linked in a point-to-point serial manner making up a continuous ring, demanding just one pair of transmitter and receiver with a transmission line going in and out of the node. Anyway this implies the use of a complex communication protocol that guarantee the synchronization. Moreover, this kind of structure presents two main problems that are better analyzed in [23] :

1. If a node or one communication link quit to work, the whole ring fail.
2. Delay that is generated as data propagates through the ring, implying that the farthest nodes respect to the controller will have a greater latency than the ones that are nearer.

2.2.4 *Daisy-chain Structure*

This is a sub set of the ring topology, as can be seen in the Figure 2.4, where there is no return to the master and represents the easiest method to add more devices into a network. Despite it is a scalable topology , it is also unsafe since it depends on the the fail of a single point.

2.2.4.1 *Propagation Delay Problem*

The delay generated in the network represents a significant problem for power electronics systems and motion control systems, since these systems need to work in synchronous way. An example can be the regulation of movement in a motion control system. As explained in [19] and [24], such a systems exchange data via a plastic optical fiber (POF) to overcome this delay. In fact, each terminal has two fibers linked to it, one for receiving information and the other for transmission. Clearly, to avoid and/or minimize this delay, synchronization has to be implemented. So, a synchronization signal is used, that once sent, reach the first phase leg in a daisy-chained almost instantly, being the delay on an optical fiber very small. A lot of works have been done on this topic. In [24] the delay is 468 ns with a transmission rate equal to 125 Mb/s. In [19] it is one bit per node but with the slower speed of

communication (2.5 Mb/s) the delay is about the same. Therefore, the delays are independent of a switching frequency of the converter, but are nearly related to the data transmission rate, that is an increase of communication speed implies a decrease of propagation delay. In [25] a power electronics system with phase-leg control in daisy-chained are analyzed by means the simulation of a three-phase boost converter, in particular waveforms that forecast the consequence of the delay and help define system requirements are presented.

2.3 AN OVERVIEW OF COMMUNICATION PROTOCOLS FOR POWER CONVERTERS

With the spread of distributed control schemes adopted by power converter systems, the role of communication has become extremely important, while in the power converters systems relying on a centralized control communication is generally used for routine functions such as monitoring and setting of reference values. The implementation of a communication protocol depends on the requirements imposed by power converters. In fact, since the large growth in the semiconductor technologies used by converters, today switching frequencies in the order of 20 kHz have been reached, implying a fast real-time communication and sampling interval in the order of tens of microseconds.

The choice of the protocol is highly important because of a lot of factor are based on it, like packet size, capability to reconfigure quickly, flexibility and scalability. Clearly in a distributed control schemes, a small processing time at the slave controllers and the synchronization between the modules are critical. Another important constraint is the noise and the interference due to the switching devices. To remove these interferences the use of an optical fiber is suitable, since it is immune to them. Moreover, with the use of optical fiber, the link length is not more a problem since fiber can reach distance in the order of kilometers. Also the number of nodes is significant since the number of I/O pins at the master are relied on them. Regarding the communication mode, the most used one is the master-slave mode, while master-master and slave-slave are used in case of master or slave device fault.

In the telecommunications networks in which data like voice, audio, video or any other kind of data are sent, each frame can be on the order of kilobytes. By contrast, here we are dealing with short messages on the order of some byte. Networks that handle this kind of packet are called *Control Networks*. Clearly the goals of this network are different from those of data network, in fact while the goal of data network generally consist in maximize the throughput, the goals of control networks are reliability, modularity and predictability.

The growth of these networks began at the beginning of 1980 with the advancements in the world of semiconductor technologies, when they started to be used in digital control. Over the years a lot of standard have been proposed for different purposes like motion controls, building automation, automatic meter reading and many others. One of the most important reason for which these networks are widely used in the automation system, is their low-cost, in fact all standard need an optical fiber (previously a twisted pair cables) to connect each other. Depending on the applications and their requirements, a lot of communication protocols have been developed and defined as standards such as CAN, SERCOS, MACRO, and PESNet. They represents the basis for our study from a communication protocol point of view and are shortly described below. In fact they are the most significant options for power converters since they achieve most of the criteria discussed previously in Section 2.1. Furthermore, other important protocols are explained in [26].

2.3.1 *Controller Area Network (CAN)*

This is a message-based protocol largely used in automotive to enable micro-controllers and devices such as engine management systems, ABS, gear and lighting control, to communicate with each others without a host computer, in order to obtain more reliable and safe vehicles. It was developed in 1986 after the great growth of the semiconductor world and the consequent spread of electronics devices by Robert Bosh, in order to overcome the problems present in the previous methods of communication in which each device was connected to the other using a point to point wiring. In fact with the CAN, each electronic device can exchange information with each other over a common serial bus, as depicted in Figure 2.5, decreasing in this way the bulkiness and complexity of the system and offering flexibility, good speed and reliability. It is made of different nodes and each of them has 3 main components:

- an host controller to handle the function of the node;
- a CAN controller to convert the messages in the node;
- a CAN transceiver using a CSMA protocol to transmit the message over the serial bus

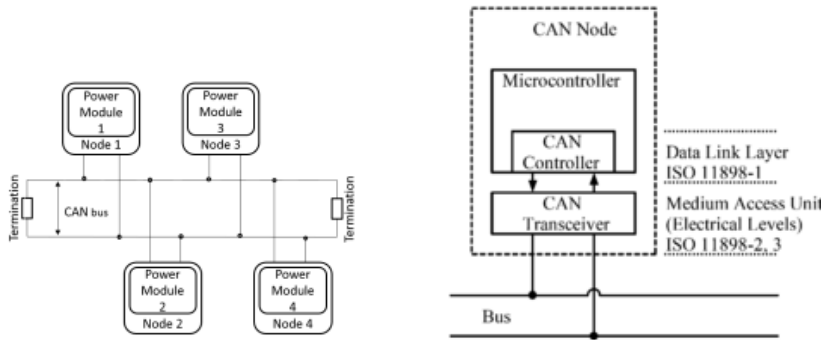

Figure 2.5: CAN configuration for power converters and its node structure, (Vaidya 2017)

2.3.2 Serial Real-time Communication System (SERCOS)

SERCOS is a standard interface used in industrial control system in order to provide hard real-time and high performance communications between motion control and digital servo drives. There exist three different version of this standard:

1. SERCOS I was developed in 1991. It use an optical fiber as transmission medium and a ring topology as communication topology, reaching a data rate between 2 and 4 Mbps.
2. SERCOS II was released in 1999. It support bigger data rates respect to the first version, such as 2,4,8 and 16 Mbps.
3. SERCOS III was introduces in 2003. In this version data rate reaches 100 Mbps. Moreover, it combines the hard real-time of SERCOS I with the Ethernet standard.

2.3.3 Motion And Control Ring Optical (MACRO)

It is a high bandwidth and wired field bus protocol for machine control networks. In general, it uses an optical fiber and it is based on a master-slave ring topology. Thanks to single-plug connections the wiring complexity in large system is minimized, in fact a single fiber optic can produce a controller having several features like position feedback, flag status and machine input status; also the same wire can communicate to other devices on the MACRO network. Other important benefits are the noise immunity thanks to the use of the optical fiber; the speed with a data rate of 125 Mbps and the simplicity since a transmission based on MACRO ring does not require intervention.

2.3.4 Power Electronic System Network (PESNet)

The PESNet protocol was developed from Milosavljevic in 1999 [23]. He started from MACRO protocol and Fiber Distributed Data Interface (FDDI) to define the physical and data link layer, in order to obtain a link between the hardware and the applications manager with important characteristics such as noise immunity, network synchronization and enough channel bandwidth. The topology is shown in Figure 2.6. As can be seen, it is a master-slave ring structure, where each nodes has two fiber attached to it, one comes in and one comes out. The PESNet controller is the master and it is in charge of transmits data to all nodes that are slaves. Each slave receives data once every communication cycle that corresponds to one switching cycle of the converter. When a node receive data, two behaviors are possible: if it is in the passive state, it just transfer data to the next node, while in the active state, that is when the node is addressed, it start to transmitting its own data and store the received data. PESNet also use DSP to implement control algorithm and FPGAs for communication interface.

Over the years, a new version of the PESNet has been developed with new features. Francis in his works [27], pointed out an architecture for control of high power converters using two different version of the PESNet protocol, the old one PESNet 1.2 and a new one PESNet 2.2. In particular, he underlines all the drawback of the older version, explain how its performance are strictly related to the order of the node in the ring. In fact, if an additional node is added in the ring, it produces an extra transmission delay that would desynchronize the nodes because of the technique used to synchronize them. As said, it also gives an overview about the improvements of PESNet 2.2 such as adjustable packet size, fault tolerant clock, improved synchronization, multi-master system and variable ring structure. Moreover in [28], Francis sharpens the importance of the FPGAs in overcoming the problem of time critical signal processing for power converters.

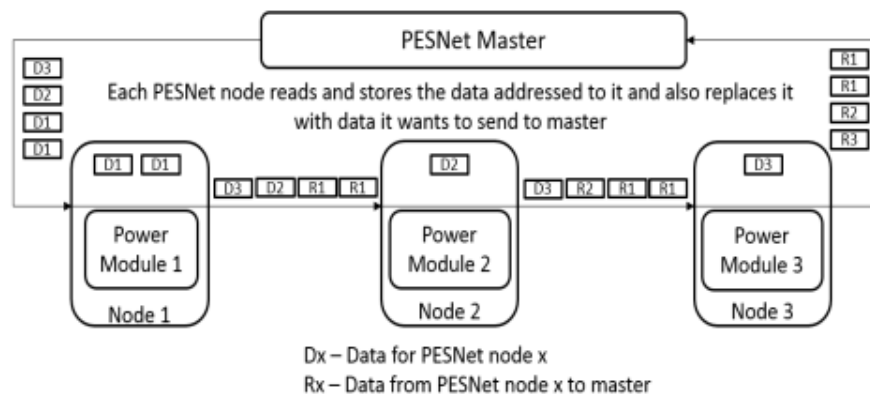

Figure 2.6: PESNet topology and functioning of data cycle, (Vaidya 2017)

2.4 THESIS PURPOSE

As explained in Chapter 1, power electronic converters (PECs) are assuming a fundamental role in modern society, in rapid growth thanks to vehicles electrification and power generation from renewable sources, and the related conversion and energy storage. Their fields of application are countless, from green vehicles to more electric aircrafts, renewable energy production, smart grids, home appliances and motor drive control. Accordingly, digital control is becoming the enabling technology for many engineering fields such as PECs, and also suggesting the possibility of new and better integration of advanced power conversion and ICT services. Traditionally, each PEC has a dedicated embedded controller on board (centralized control), handling the brute force of switching power converters attached to the power stage. Such digital controllers are intimately coupled to the switching power stage, with maximum distance and layout restrictions dictated by electromagnetic compatibility (EMC) requirements. New power semiconductors technologies based on Silicon carbide (SiC) and Gallium nitride (GaN) wide-bandgap devices promise higher voltage and much higher kVA per unit of volume of the converter. Therefore, EMC issues and PCB layout restrictions are becoming everyday more compelling, posing severe challenges to the power electronics designers. Moreover, the State of the Art about the control of PEC is mainly focused on the use of optical fibers as “one signal per fiber”, that is using the fiber as an opto-isolator and so exploiting the characteristic of immunity of optical fibers towards electromagnetic interferences (EMI) coming from PEC. In this way, they use the optical power carried by the fiber as an energy source rather than carrying data, making sure that a device can be remotely powered. Ultimately, the power stage and the embedded controller will be decoupled through the optical communication line, fixing once for all the EMC problems, layout restrictions, and simplifying the co-design of the power and control stages. The physical decoupling of the power and control units will permit to optimize the design of the two sides separately, opening the stage to new converter topologies, integration of the power stage within the application and more in general a block box approach where the two units can be easily replaced or updated independently. Finally, the presence of a standardized, insulated communication link between the field, represented by the power unit, and the Internet, represented by the control unit, might open infinite possibilities for a wider application of ICT into power conversion, as will be explained in the last chapter.

In this work, we investigate an original solution in the use of optical fibers for remotizing the control of PECs, passing in this way from a centralized to a shared centralized control. In particular, it deals the feasibility of shared centralized control and communications units

able to control and synchronize different power converters, enabling real-time control and telemetry for diagnostic in such a challenging environment. Our research is focused on defining a proper communication protocol for the photonic bus able to link together PECs and the Control Unit (CU) and to handle more than 10 devices (N_D) in real-time by relying on time-division multiplexing, with a fixed distance between each node. The optical communication link connects the switching control to the converter control, following the line of separation between the expertises of the power electronic engineer and the control engineer. Control wise, the PEC becomes a black box compatible with any off-board controller, now immune from the Electromagnetic Interference (EMI) produced by the power switches.

Besides proposing the described solutions, we also present some preliminary experimental results. Accordingly, a proof-of-concept demonstrator, able of controlling a 100W-brushless servomotor via a three-phase voltage source inverter (VSI), is presented and tested. It consists of a Control Unit and a remote node, that have both an on-board Field Programmable Gate Arrays (FPGA) to elaborate the data, while for the implementation of the photonic bus, a standard pairs of A4a.2 Poly-Methyl MethAcrylate (PMMA) Step Index Plastic Optical Fiber (POF) are used, establishing in this way a link for real-time high data transfer rate between PECs and the control unit (CU). Xilinx Artix FPGA with integrated optical transceiver are used for ease of development. Regarding the photonic bus, optical fibers have been chosen not only for their immunity towards EMI, but also because they offer a high data transfer rate and low latency for the purposes of PEC tele-controlling, diagnostics and data collection from the field. Moreover, the choice for plastic fibers as transmission medium is driven by their low cost, ruggedness and ease of deployment, as they can be simply cut using a pair of scissors and inserted in optolock transceivers without any specific precautions nor special tools.

Finally, the scope of our demonstrator is to prove the feasibility of the single fiber approach using a simple FPGA implementation. The easier the communication (hardware wise), the more likely this project will be successful and applicable to power units of any size and cost. Therefore, the power converter must be as simple as possible, and rely on existing hardware as far as possible.

2.4.1 *Example: Control of a PWM power converter*

Generally, for a three phase motor controllers, six perfectly timed PWM signals must be generated with minimal processor overhead to control H bridges. Usually, 3-phase induction, permanent magnet synchronous and BLDC motor drives, are supplied with a 3-phase hard-switched VSI (Voltage Source Inverter). So, three complementary

pairs of PWM signals are requested to control, respectively, the high and low switches of the 3-phase inverter.

In generic terms, a power electronic converter is a device that converts the input supply voltage into a variable output voltage as demanded by the load conditions through switching actions. For example in its simplest form, the DC-DC Buck converter has a single switch as shown in Figure 2.7 and the output voltage can be controlled through the duty cycle of the switch. The duty-cycle turns into on-off gate commands of the power switch through PWM or other forms of modulation. In practical scenario, the output voltage is used for closed loop

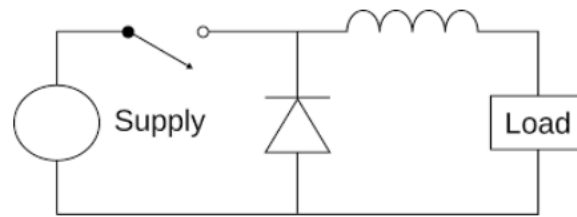

Figure 2.7: DC-DC Buck Converter

control of the load state variable, i.e. the load current in this case. This implies that a feedback channel carries information of the load current to a CU which processes the data and sends the duty cycle through an input channel. In the case of buck converter which has a single switch, the input channel carries a single duty-cycle value (between 0-1) and hence a resolution of around 10-12 bits are sufficient.

However, in converters with higher complexity, the number of switches increases which, as far as the communication channels are concerned, only increases the width of the channels to send the duty cycle of many switches.

Conventionally, as many wires/cables as the switches are used such that each switch has a unique cable to provide the duty-cycle. Moreover, the feedback channel typically has 3/4 cables in motor drive applications (3/4 analog feedback + encoder digital feedback).

The objective of this work is to replace this bundle of cables with a single optic fiber as shown in the Figure 2.8. The optic fiber provides a single platform for the input and feedback channels. It also has an inherent immunity towards EMC which is a source of concern in high power applications.

So, the power unit, the master of the PWM timing, comprises of an FPGA along other auxiliary gate driver circuits for the compatibility between FPGA and power converter. The two primary functions of the FPGA at power unit are transmission of feedback data (after A/D conversion) to the control unit and reception of input data on the duty cycle from the control unit. Once the data is received, it is send to the gate drivers of the power converter. The control unit has an FPGA and

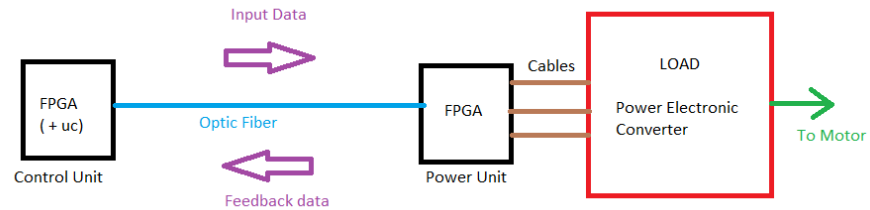

Figure 2.8: System layout with optic fiber communication

possibly a μC which is the brain behind the control that processes the feedback data and finds the optimum duty cycle to be transmitted to the power unit.

2.4.1.1 PWM task synchronization

As just described in Chapter 1, PWM is used to control the speed and the position of the motor by regulating the amount of voltage across its terminal. The PWM drives the motor with several "ON-OFF" pulses and also changing the duty-cycle. In particular, the power supplied to the motor can be controlled by changing the width of the pulses, changing in this way the average DC voltage applied to the terminal of the motors. In this way, the speed of the motor can be handled, i.e. the longer the pulse is "ON", the faster the motor will rotate and viceversa. In other words, the larger the pulse width, the more average voltage applied to the motor terminals, the stronger the magnetic flux inside the armature windings and the faster the motor will rotate, as depicted in Figure 2.9. The use of PWM to control a small motor

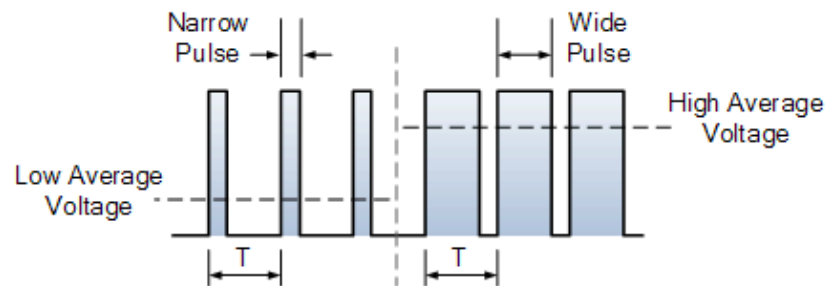

Figure 2.9: A typical PWM modulation

has the benefit in that the power loss in the switching transistor is extremely low since the transistor is either fully "ON" or fully "OFF". Accordingly, the switching transistor has a much decreased power dissipation giving it a linear type of control which results in better speed stability. Also the amplitude of the motor voltage keeps constant so the motor is always at full strength. The result is that the motor can be rotated much more slowly without it stopping.

In Figure 2.10, the chronological working of the system, referring to a single task is depicted, with sampling time equal to the PWM period (single sampling mode) or to a sub-multiple of the PWM (multiple sampling or oversampling).

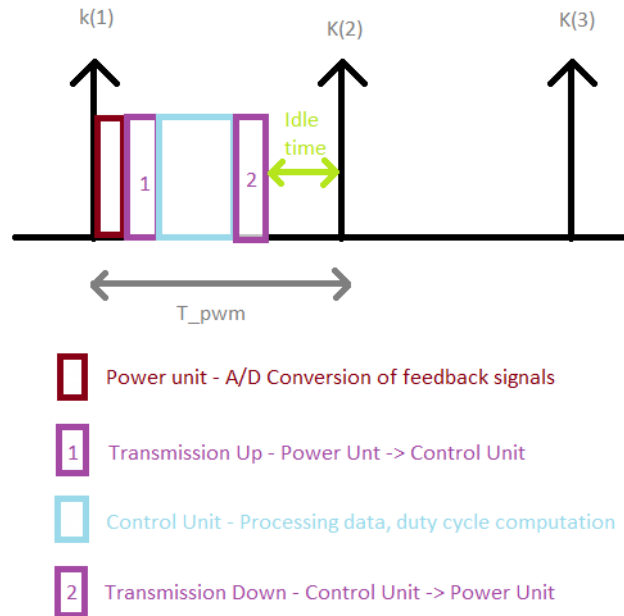

Figure 2.10: Sampling time scale

As can be seen in Figure 2.11, at every sampling instant $k(n)$, the feedback signals are measured, that is when the interrupt occurs; at every time $(k + 1)$ commands are executed by the power unit and PWM values are updated. The feedback measurements are transmitted down to the control unit where it is processed to find the duty cycles which are sent back to the power unit. The idle time can be utilized for other supplementary activities such as temperature monitoring, fault diagnostics etc. The typical sampling and execution frequency depends on the application and it is in the range of a few kHz up to 20 kHz. However, since the use of wide-bandgap power semiconductors (SiC and GaN) is increasing the PWM, also the sampling frequency could be increased up to 100 kHz.

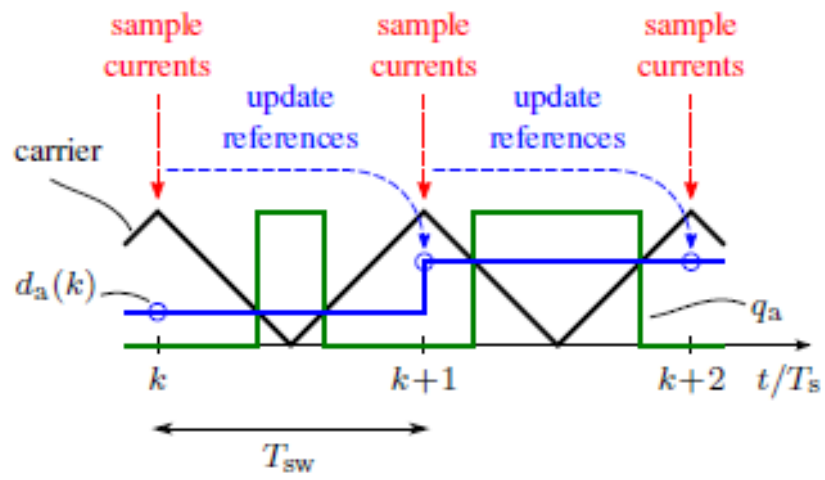

Figure 2.11: Synchronization of sampling and PWM output update

2.5 OPTICAL COMMUNICATIONS

As explained in Section 2.4 there are a lot of reasons for which we have used a plastic optical fiber to build our demonstrator. In this section the motivation and the advantages for this choice are cleared.

Frequency used in optical communications are very high. They come near the visible light spectrum, from which the traditional denomination “optical”. However, the light of optical systems cannot in general be seen, in fact only a small subset of optical systems uses visible light. In the Figure 2.12, is depicted the electromagnetic spectrum, that indicates the set of all possible frequencies of electromagnetic radiation and covers electromagnetic waves with frequencies ranging from below one hertz to above 1025 hertz, corresponding to wavelengths from thousands of kilometers down to a fraction of the size of an atomic nucleus. The waves in the interval between the visible light and the radio waves, at low intensity have little energy and are poorly damaging, the radiations between the ultraviolet and gamma rays instead have more energy, are ionizing and therefore can damage the human beings. As shown in the figure, an electromagnetic wave can be described by the point of view of the frequency or from the point of view of the wavelength. Their relationship is:

$$f = \frac{c}{\lambda} \quad (2.1)$$

where c is the speed of light in vacuum, and is equal to 299 792 458 m/s. As we can see, the visible spectrum, that is the set of the colors perceivable by the human eye giving life to the phenomenon of light, goes from 400 nm to 700 nm, i.e. from violet to red. The fiber optic wavelengths are placed between the infrared and the visible spectrum.

2.5.1 Description and characteristics of optical fibers

Optical fibers were developed in the 1970s by Corning with attenuation sufficiently low for communication purposes (about 20 dB/km) and at the same time the semiconductor lasers were made in GaAs, compact and therefore suitable for fiber-optic telecommunication systems. Over the years, a lot of progresses have been done. In fact, the first generation works at 800 nm with a bitrate equal to 45 Mb/s and had repeaters spaced of 10 km, while the third generation of optical fibers operates at 1550 nm with a bitrate equal to 2.5 Gb/s and with repeaters spaced of 100 km. From the fourth generation optical amplification was introduced to reduce the need for repeaters and the Wavelength Division Multiplexing (WDM), to increase the capacity of the fiber reaching 14 Tb/s on a single fiber 160 km long. About Italy, in 1977 Turin became the first Italian city wired with an experimental optical network, thank to the CSELT group and with the collaboration of Sirti and Pirelli.

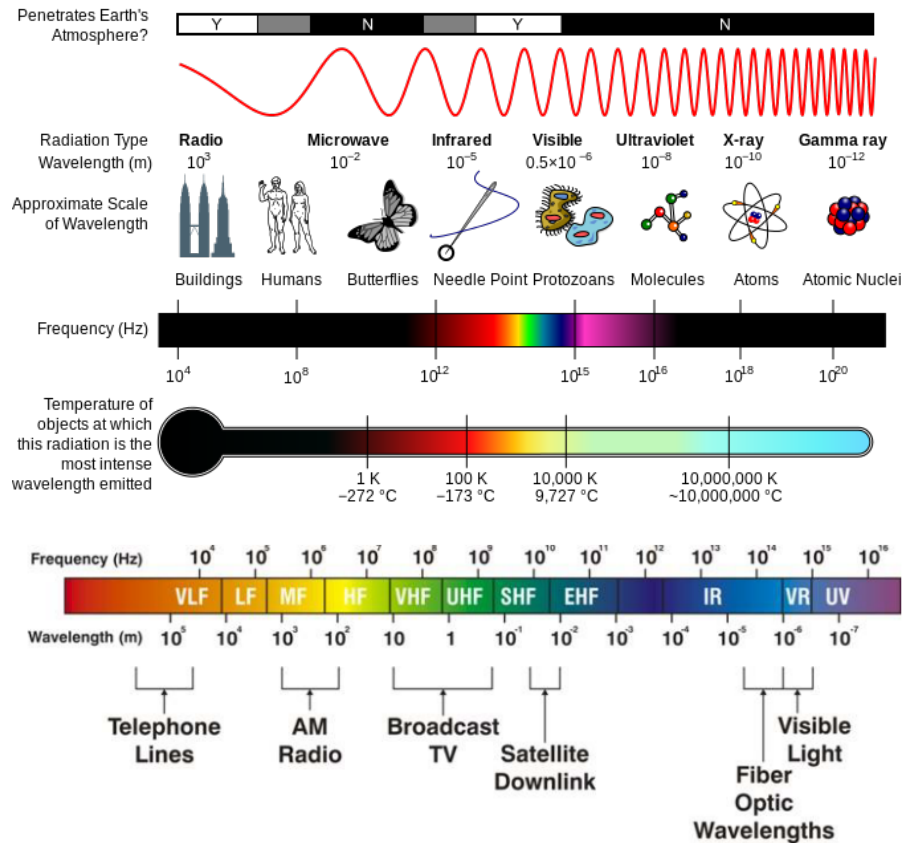

Figure 2.12: Electromagnetic Spectrum

Optical fibers, shown in Figure 2.13 consists of transparent and flexible filaments (which diameter is slightly thicker than that of a human hair) made of *Silica* (glass) or *Polymer* (plastic) material, built in order to conduct the light inside. Optical fibers are dielectric waveguides based on the inhomogeneity of the medium whose core is the place of the electromagnetic field. In other words, they make it possible to convey and drive within them an electromagnetic field of sufficiently high frequency (generally near the infrared) with extremely limited losses. They are commonly used in telecommunications as a means of transmission of optical signals over long distances and at higher bandwidths, providing better services compared to other forms of communication, being durable and also cheaper. They are also immune to the electrical noise and to the difficult atmospheric conditions.

For all these reasons, at present, are replacing traditional copper wires as transmission medium that use electrical impulses to send the signal differently from the fiber that uses light pulses, supplied by a light source like a LED or laser. One of the most important advantages of optical fiber over a copper wire are increased bandwidth and durability, in fact due to the increased level of bandwidth expected from the explosion of the Internet and multimedia technologies, bandwidth

will soon outgrow the capabilities of copper. Hence, an optical fiber is a cost effective replacement. Other important benefits of optical fibers over copper wires are:

- low attenuation, which makes long distance transmission possible without repeaters;
- immunity from electromagnetic interference;
- excellent resistance to adverse weather conditions;
- low BER values;

Moreover, copper cable are extremely sensitive and difficult to maintain. So, optical fibers are largely used in several fields such as telecommunications, Networking, Medical and Defense.

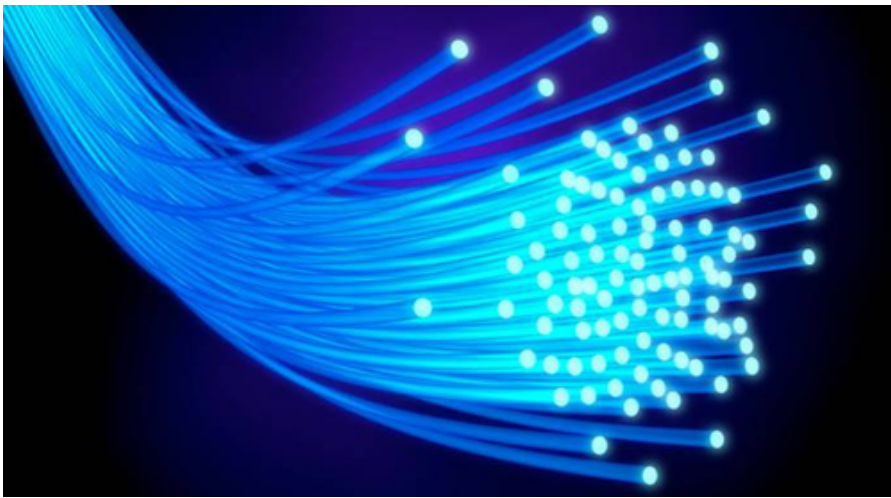

Figure 2.13: Optical Fiber

An optical fiber is composed of two concentric layers of extremely pure transparent material: the *core* and the *cladding*, that can be made of silica or plastic polymers. The two layers are made of materials with slightly different refractive index, in fact the cladding must have a lower refractive index (typically 1,475) than the core (about 1,5). As a further feature, the cladding must have a thickness greater than the damping length of the evanescent wave, in order to capture the light that is not reflected in the core. Fiber cores are made from very high purity materials to guarantee that the light energy is not absorbed or scattered by impurities. Radiation, absorption, and scattering are all forms of energy loss, also known as attenuation. By keeping such losses as low as possible, fiber allows light and the information it carries to travel great distances from the original source.

The behavior of the light inside an optical is the following: the light entering the core at a certain angle (limiting angle) propagates through a series of reflections to the surface of separation between the two core

and cladding materials. Outside the fiber there is a protective polymer sheath called *jacket* which serves to give resistance to physical stresses and corrosion and to avoid contact between the fiber and the external environment.

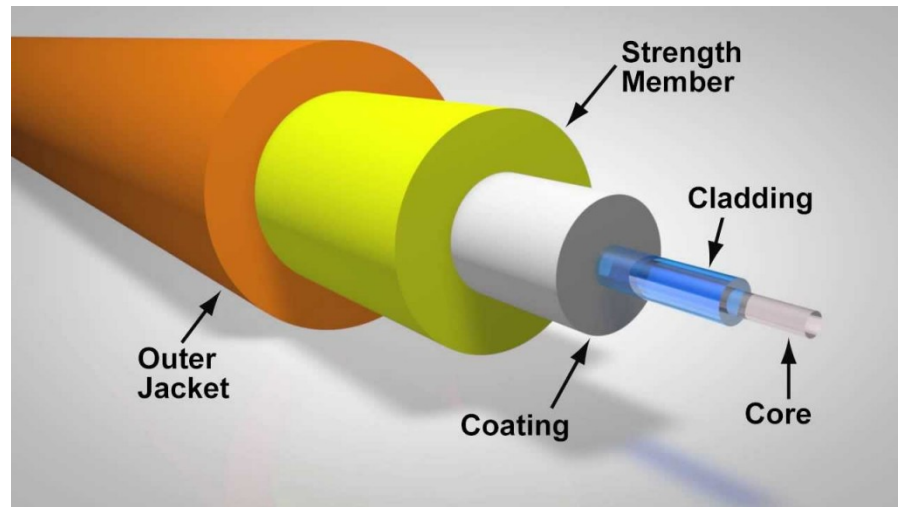

Figure 2.14: Structure of a typical single-mode fiber

Different types of fibers are distinguished by core diameter, refractive indices, characteristics of the material, transition profile of the refractive index and doping (addition of small amounts of other materials to change the optical characteristics).

2.5.1.1 *Refractive Index*

The refractive index of a material is a dimensionless number that quantifies the decrease in the propagation speed of the electromagnetic radiation when it passes through a material. The decrease in the propagation speed is accompanied by the variation of its direction, according to the phenomenon of refraction.

$$n = \frac{c}{v} \quad (2.2)$$

where c is the speed of light in vacuum and v is the speed of the light in the medium. For example, the refractive index of water is 1.333, so light will travel 1.333 times faster in vacuum than in the water. Some representative refractive indices for $\lambda = 589.3$ nm are shown in Table 2.1:

2.5.2 *Behavior*

In the optical fibers there is the so-called total internal reflection, whereby the discontinuity of the refractive index between the materials of the core and of the cladding traps the light radiation until it maintains a rather grazing angle, in practice until the fiber makes too

Table 2.1: Refractive Index

Material	n
Vacuum	1
Air	1.000293
Water (20°)	1.333
PMMA	1.49
Silica	1.45

sharp curves. This phenomenon is depicted in Figure 2.15, where two light rays affect the interface between the core and the cladding inside the optical fiber. The beam *a* affects at an angle θ_a greater than the critical total reflection angle and remains trapped in the core; the beam *b* affects at an angle θ_b less than the critical angle and is refracted into the cladding and then lost.

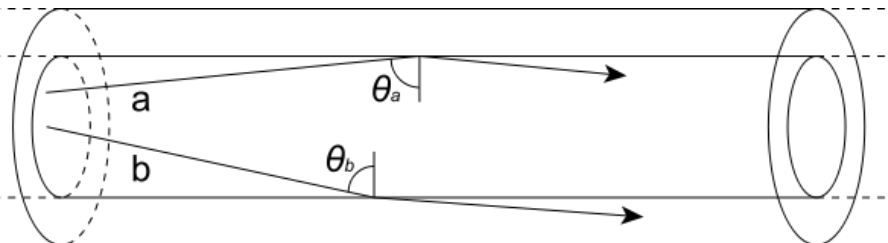

Figure 2.15: Total internal reflection (a) and external reflection (b)

2.5.3 Attenuation

Ideally, optical fibers are a perfect transmission medium. In fact, in addition to not being affected in any way by electromagnetic interference or cross-talk, if properly structured to ensure total reflection of the input signal theoretically allow you to completely transfer the power input in the output.

In practice, however, physical phenomena intervene that cause losses of attenuation of power along the fiber, i.e. the reduction in intensity of the light beam as it travels through the transmission medium. These losses, usually statistically assessed in terms of specific attenuation or in dB/km, are due to:

- intrinsic properties of the medium;
- presence of impurities inside the material;
- Rayleigh scattering
- absorption;

Accordingly, plastic and glass optical fibers will have different losses in terms of dB/Km, depending of their material and the related wavelength in which they work.

2.5.4 *Glass Optical Fiber*

Common experience teaches that monolithic glass is a fragile material. If instead it is spun at a diameter of less than a tenth of a millimeter it loses its characteristic fragility to become a material with high mechanical resistance and resilience. Since the cables have no electrical components, glass optical fibers can work at impressive high temperature, up to 1200°C, where it starts to degrade. This important features make them applicable in different high-temperature applications such as furnaces, ovens and condensers in large engines. Other usual uses are fabrics for thermal insulation, electrical insulation and sound insulation.

2.5.4.1 *Single-mode and multi-mode glass optical fiber*

Within an optical fiber the signal can propagate in a rectilinear way (single-mode) or be reflected a very large number of times (multi-mode). Single-mode fibers allow the propagation of light in only one way and have a core diameter of between 8 μm and 10 μm . They are most frequently used for long-haul networks and communications over long distances, in fact because they accommodate only one path of light, there's less probability for overlapping signals and distortion. Otherwise, multi-mode fibers allow the propagation of multiple modes, and have a core diameter of 50 μm or 62.5 μm . Data centers and office networks, prefer multi-mode fiber since it can manage wide amounts of data in a cost and space efficient manner, in fact this kind of fiber are used for short-distance communication links and for applications where high power must be transmitted. The cladding typically has a diameter of 125 μm for both of them.

It is possible to know a priori the number of possible modes for a wavelength radiation λ that crosses a step-index fiber of diameter with numerical aperture NA . In optical fibers, the numerical aperture indicates the number of modes in which light can propagate through the fiber. It is also closely related to the width of the acceptance cone to have total fiber reflection.

$$NA = n \sin \theta \quad (2.3)$$

where n is the refractive index of the external medium (1.00 for air, 1.33 for pure water) and θ is the maximal half-angle of the cone of light that can enter or exit the fiber.

Multi-mode fibers allow the use of cheaper devices, but they suffer the phenomenon of inter-mode dispersion, whereby the different

modes propagate at slightly different speeds, and this limits the maximum distance at which the signal can be received correctly. On the other hand the single-mode fibers are priced much higher than multi-mode ones, but they are able to cover distances and to reach much higher speeds. Multi-mode fibers can be further divided into step index and graded index fibers:

- In the step index (SI) fibers the refractive index is constant along the whole core section and changes suddenly when the cladding is encountered;
- In the graded index (GI) fibers the refractive index changes gradually from the core to the cladding, allowing the use of multicolor light.

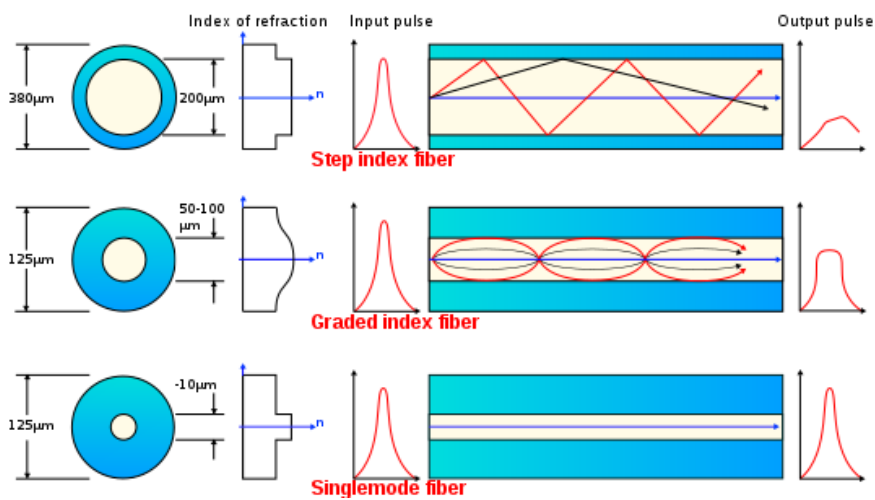

Figure 2.16: Optical fibers comparison

Generally, because of their extremely small diameter they also have a small numerical aperture ($NA=0.16$) and are difficult to connect.

2.5.5 Plastic Optical Fiber

Plastic Optical Fiber (POF) is an optical fiber usually uses Poly Methyl MethAcrylate (PMMA), also known as acrylic glass, a resin as the core material, and fluorinated polymers for the cladding material. They have been standardized and categorized by IEEE 802.3 GEPOF SG in IEC 60793-2-40 and belong to the A4 group. In particular, the international standard IEC 60793-2-40 describes the characteristics and applications of category A4 fibers and the related sub-categories A4a, A4b, A4c, A4d, A4e, A4f, A4g and A4h. These fibers have a plastic core and plastic cladding and may have step-index, multi-step or graded index profiles and perfluorinated polymer graded index profile, shown in Figure 2.17. Thus several different fibers, having different factors such as core diameter, cladding diameter, numerical aperture, operative wavelength, attenuation and bandwidth, exist, such as SI-POF, GI-POF and DSI-POF. In this work, we have used A4a.2 PMMA Step Index plastic optical fiber.

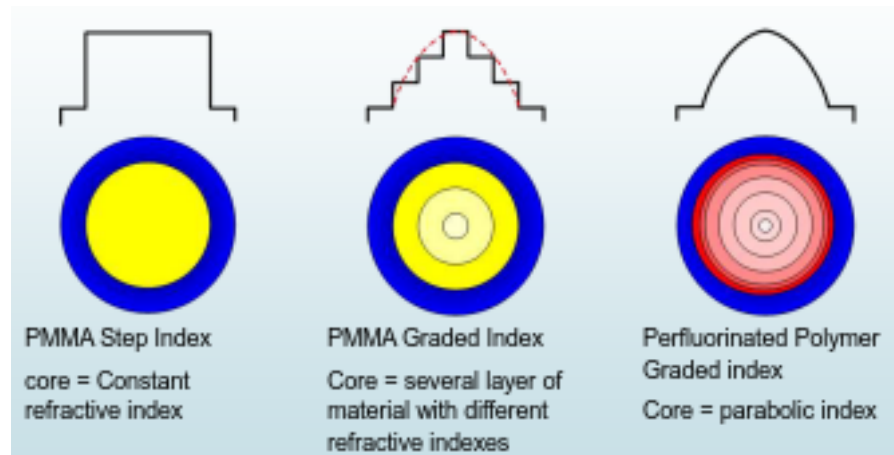

Figure 2.17: Index profiles for plastic optical fibers

Thanks to their material, they present a lot of advantages respect to glass optical fiber:

- They are much easier to manage (can run along skirting boards, under carpets and around tight corners). This because POF has a shorter bend radius, and is more resilient to damage and abuse than glass due to its intrinsic material characteristics;
- They have an important position in military communication network and multimedia equipment in the data transmission, being ideal for short-range communication network;
- They are extremely cheap and their installation and maintenance is very simple, in fact special tools or techniques are not necessary. No train are necessary to do the installation, just simply work with scissors, polish, hook it up and it works.

- Guarantee high quality service and high data rates;
- They are also extremely safe, using harmless green or red light that is easily visible towards the eye. So can be installed in a house without risk to inquisitive children;

As can be seen in Figure 2.18, POF have a larger diameter (1 mm) respect to the glass optical fiber, so they have also an higher numerical aperture. This imply that this kind of fibers are exclusively multi-mode. So, in the plastic optical fibers the 96% of the cross-section is the core that facilitates the transmission of light. POf are also called

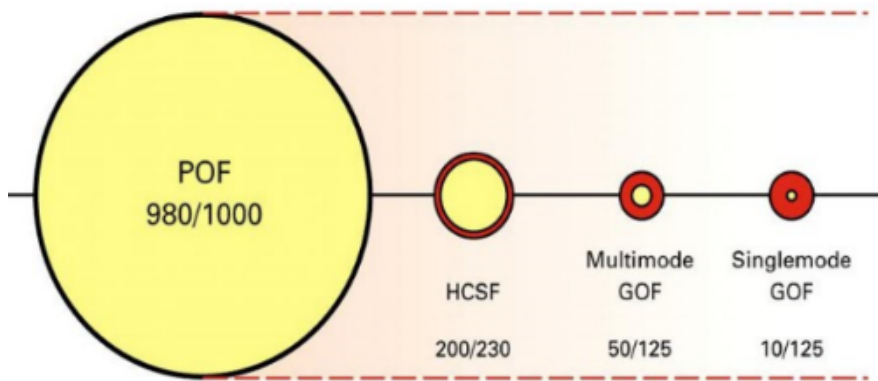

Figure 2.18: Comparison between core/cladding of plastic and glass optical fiber

the "consumer" optical fiber, since the low cost of themselves and their equipment (optical links, connectors and installation). They are especially suited for applications that require continuous flexing of the fiber and for developing new applications with high bandwidth, such as IPTV and Triple Play services. However, due to the attenuation and distortion characteristics of PMMA, they are commonly used for low-speed, short-distance (up to 100 meters) applications, such as:

- Electronic appliances and motor vehicles;
- Digital home appliance interfaces;
- Home and Industrial Networks (PROFIBUS, PROFINET);
- Car Networks (MOST);

2.5.6 Transmission Windows for Plastic and Glass Optical Fibers

In optical communications, the transmission spectrum is usually described in terms of wavelength instead of frequency. Each effect that contributes to attenuation and dispersion depends on the optical wavelength. Attenuation is a very important factor in determining the maximum length of a fiber link, and depends on the material

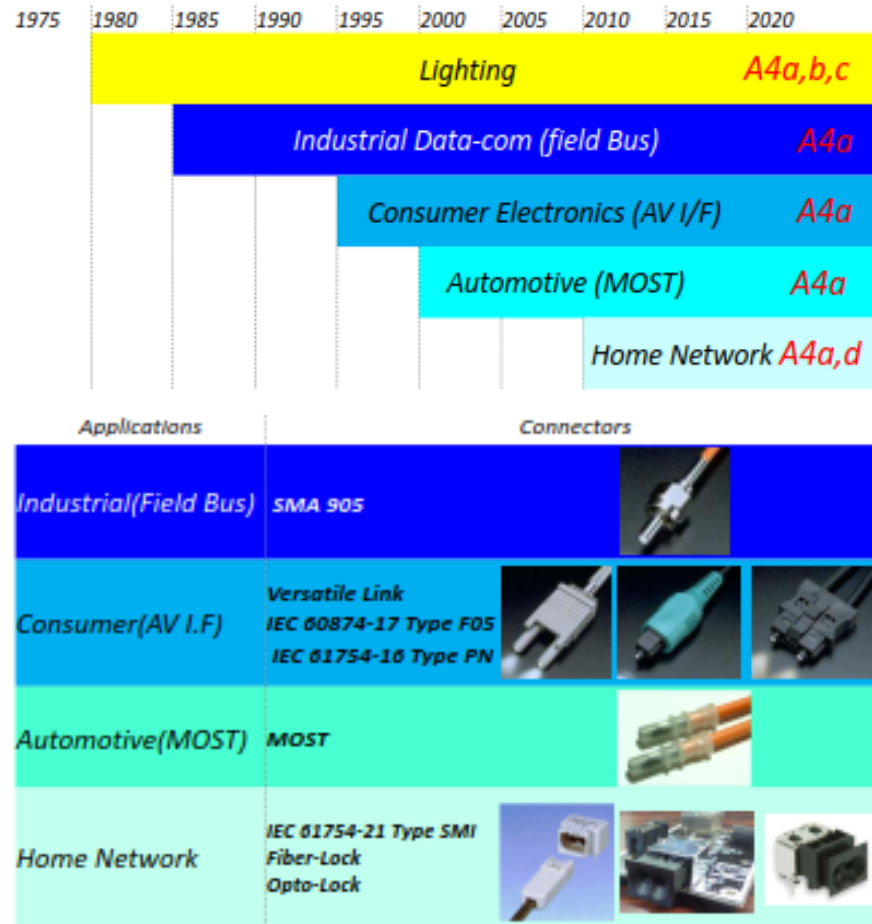

Figure 2.19: Expansion of Data applications for POF and connector interfaces for A4a POF

properties and the transmission wavelength. There are wavelength bands (or windows) where these effects are weakest, and these are the most favorable for transmission.

Attenuation of the signal within optical fibers is usually expressed in the logarithmic unit of decibel. The decibel, which is used for comparing two power levels, may be defined for a particular optical wavelength as the ratio of the output optical power P_0 from the fiber to the input optical power P_i .

$$A = 10 \log_{10} \frac{P_0}{P_i} [dB] \tag{2.4}$$

Generally, attenuation is related to losses introduced by one kilometer of fiber, hence the specific attenuation is:

$$A_s = \frac{A}{L} [dB/km] \tag{2.5}$$

2.5.6.1 *Transmission windows for Glass Optical Fiber*

Combining the different phenomena of attenuation, refraction, dispersion, three main transmission windows, with increasing performance, can be identified. They are shown in Figure 2.20.

1. First window (800 to 900 nm): Central wavelength at 850 nm. It is in the visible field and it is mainly used with cheap diode lasers with multimode light. It allows to make connections of 275 m on 62.5 / 125 fibers and 550 m on 50/125 fibers.
2. Second window (also called O-band: 1260 to 1360 nm): Central wavelength at 1310 nm. It is used with multimode or single-mode lasers. It allows to realize connections of 5/10 km on single-mode fibers.
3. Third window (also called C-band 1530 to 1570 nm): Central wavelength at 1550 nm; it is in the "near infrared" region and is invisible. It is used with single-mode lasers. This window makes it possible to achieve the greatest distances, including 100 km connections with relatively inexpensive devices. By exploiting this wavelength, a good single-mode fiber reaches a attenuation of the order of 0.2-0.25 dB/km. The available bandwidth for the C-band is very huge and it is equal to 5 THz. This is the also called "erbium window", in fact because of its lowest attenuation, it is widely used and has become extremely important in view of the availability of EDFA (Erbium-Doped Fiber Amplifiers), that are the best and cheapest optical amplifiers, and wavelength division multiplexing (WDM) transmission system.

The wavelengths around 1250 nm and 1470 nm have absorption peaks, overtone of the vibrational absorption peak of the OH group of the fiber molecules. However, there is a chemical approach that eliminates the second peak, effectively joining the last two windows: these fibers are called "all-waves fibers".

2.5.6.2 *Transmission windows for Plastic Optical Fiber*

One of the most important drawback of PMMA-SI-POF respect to glass optical fibers is their higher attenuation. As explained, this attenuation depends on the material of the fiber, polymers have many vibrational and rotational bonds that soak up electromagnetic radiation. This effect is particularly acute at wavelengths on the red side of the visible spectrum. For this reason they are not used for long distance communication, even if today this has become an important field of research in order to have POF applicable also for transmission with long haul. Differently, glass optical fibers have an attenuation about 0.2 dB/km. This means that 95% of the launched optical power remains after 1 km of transmission. The PMMA-SI-POF attenuation

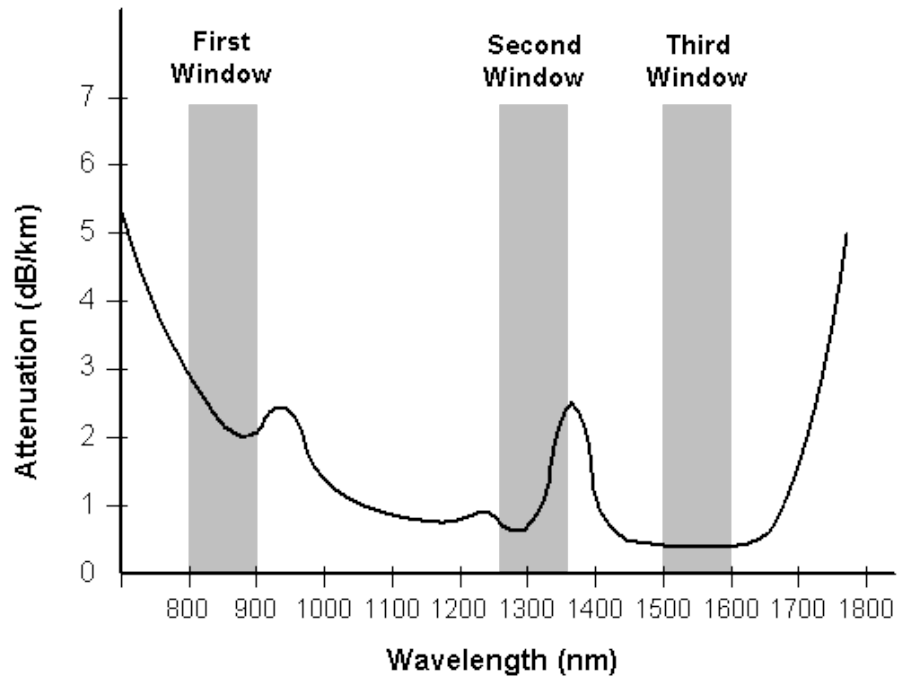

Figure 2.20: Transmission windows for a silica optical fiber

spectrum is depicted in Figure 2.21. As can be seen, POF can only provide passable attenuation in the visible spectrum from 350 nm up to 750 nm. The lowest attenuation is reached for $\lambda=570$ nm and it is equal to 85 dB/km. At 650 nm (for communication using red LED) plastic fibers have losses of about 150 dB/km.

Regarding the sources, only recently that LEDs and Resonant Cavity LEDs (RC-LEDs) sources have become disposable in the 520 nm and 580 nm, while in the past LEDs and laser were only available in the 650 nm. It's clear that, as happens with glass, three transmission windows

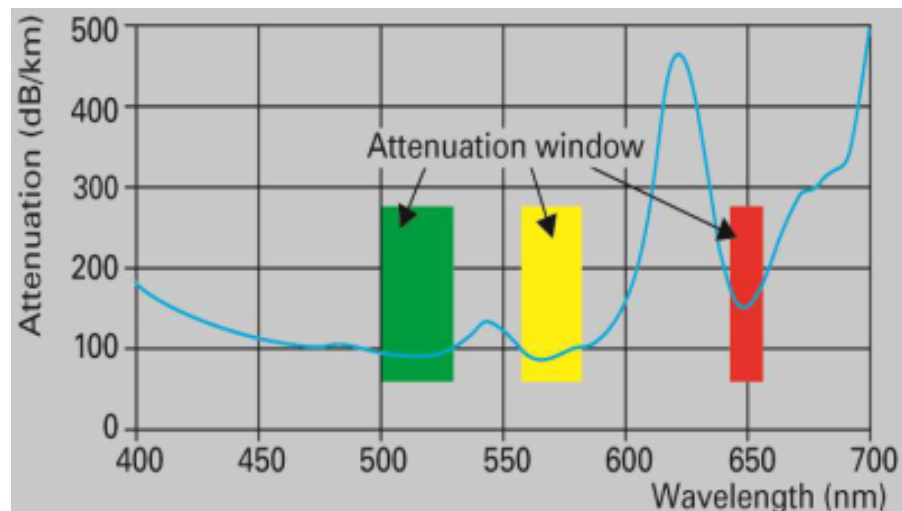

Figure 2.21: PMMA-SI-POF attenuation spectrum

can be identified, even if with very different attenuation values:

- 520 nm, with an attenuation of about 80 dB/km
- 570 nm, with an attenuation of about 75 dB/km
- 650 nm, with an attenuation of about 180 dB/km

Being in the visible spectrum, each of them can be associated to colors respectively blue-green, yellow and red. Hence, blue and yellow windows are have the lowest attenuation and longer distance can be reached, while red window have an attenuation almost doubled (0.18 dB/m) but also in this window there is a plentiful availability of components at higher speeds.

2.5.7 *State of the Art of Plastic Optical Fibers*

In order to develop a suitable protocol to handle the communication on the photonic bus, we started our research from the plentiful of works done regarding applications based on plastic optical fiber transmission medium. In fact, POFs have been recently used for data transmission on short distances and relatively low data rates in scenarios where other technologies such as UTP cables, Wi-Fi and Powerline cannot be effectively deployed because of coexistence with power cables generating unbearable electromagnetic interference (EMI).

During the last decade, interest in POFs as possible option for next-generation Gb/s links inside the home is strongly increased, mainly because of the new requirements requested by high-speed home networking. A lot of European Research projects conducted by different institutes working together like ISMB, LUC, FIRE, TUE are focused on this field and some of them are grouped in [29]. The aims of POF-PLUS Handbook [29] were the development of new components (PCB-based lased laser and photodiode, simplex duplex and ribbon POF cable) and optimize transmission techniques to enable high speed (multiple Gbit/s) optical links based on POF to aid both wired and wireless service delivery to end users in next generation networks, by using SI-POF, but also GI-POF and MC-POF. One of the key result obtained by this project was the development of prototypes for the reliable transmission of Gigabit Ethernet over 50 meters of SI-POF, using RC-LED at the transmitter [31]. Cardenas et al. in [33] proposed a media converter prototype in order to transmit data for 10 Mb/s Ethernet over a PMMA-SI-POF. In particular, Cardenas et al. reached the maximum distance of 425 m with a suitable system margin, enlarging in this way the field of applications for plastic optical fibers. Savio et al. in [32], defines a new Physical Coding Sub-layer (PCS), responsible for interfacing to the higher layer, in order to obtain a Gigabit transmission over 50 m of PMMA-POF. In particular, they used an efficient coding to reduce bandwidth requirements and

including FEC to adjust transmission errors and adding robustness to the communication. ETSI in 2015 published a document, [34], in which provides a summary of applications requirements for full-duplex 100 Mbits and 1 Gbit/s Ethernet based home networking infrastructures based on POFs. In particular, the reasons for the new requirements are analyzed, such as internet based services (VoIP, IPTV, online gaming). Afterwards, an introduction about the current home networking technologies (Ethernet, Wi-Fi) is made, followed by a description of POF based home networking technologies and their standards provided by IEEE. Finally, requirements for transmission over POF based applications are introduced. Some of the are:

- Physical layer requirements;
- Ethernet layer performance;
- Environmental requirements;
- Topology requirements

Hence, developing Gigabit communication standards for POF has become an important field of research. For this purpose, since 2014 transceivers are available in the market enabling the design of home networking equipment actually delivering Gigabit speeds into the home. For example, IEEE 802.3bv-2017, is a standard that defines a 1 Gb/s full duplex transmission over SI-POF using red LED, and it is called 1000BASE-RH.

SHARED CONTROL OF PECS THROUGH A PHOTONIC BUS

In this Chapter the scope of the thesis and the obtained results are presented. In particular, after a brief introduction about the State of the Art on the data communication in Power Electronic Converters, the proposed structure is introduced. Also a short overview about FPGA and VHDL, used for the implementation of our demonstrator, is given. After, the photonic bus is explained, focusing the attention on its implementation and on the protocol used. Finally, our demonstrator is described and the experimental result are presented.

3.1 INTRODUCTION

Power electronic converters (PECs) are becoming more and more important in the modern society. Moreover, the scaling demand for power conversion triggered the development of new devices as Silicon Carbide (SiC) power MOSFETs that were considered too costly and unreliable until very recently. Over the last years, the interest in the high-voltage (HV) SiC based semiconductor power devices and their applications is increased a lot. Some applications based on SiC power devices comprise power converter for renewable energy integration, STATCOM, FACT devices and medium voltage drivers. This work deals with PECs from an optical point of view, with the scope of bring data comings from PECs to the cloud by means the Internet of power. In particular, this thesis is focused on the advancements in the use of optical fibers for control at switching level of PECs, aiming the definition of a serial communication standard protocol in order to control the PEC using a plastic optical fiber (POF).

In the literature, a lot of works have been done about optical fibers applied to PECs. Zhang et al. in [35] present a method to increase the reliability of a 15 kV SiC MOSFET gate drive circuit using a POF based isolated power supply, replacing in this way the traditional design based on isolation transformer. They exploit the electrical isolation supplied by the POFs between the device and the power unit, in fact the use of POFs removes the parasitic CM capacitance coupling the power stage and control stage, and also reaches important size and weight reduction of the gate drive circuit. Also, they use the optical power carried by the fiber as an energy source rather than carrying data, making sure that a device can be remotely powered. In [37] and [36] are introduced applications of optical fiber Bragg grating (FBG) sensors in energy conversion systems. In particular, the authors show

the functionality of FBG in an IGBT module used in power electronics systems, such as the direct temperature measurement that allow the the determination of its thermoelectric model or the temperature characterization of an induction motor.

However in all the reported cases, the optical link is used in "one signal per fiber" manner, that is using a fiber for each transistor of the bridge. So, when the electronic board generates the waveform, each output of the PWM go through its fiber to its receiver where there is the transistor that must be controlled. This method use the fiber as a long opto-isolator being immune to the EMI. On the contrary, we transfer to the control unit only the information about how the waveform must be (just some bit). Hence, we use the fiber to link together each node and exchange data between them.

In the late '90s the US Office of Naval Research promoted the standardization of PEBBs (Power Electronic Building Blocks) for shipboard power electronics [16], later adopted by ABB and other industrial players for medium and high power converters [39]. The PEBBs are "power processors" having minimal digital intelligence on board for hardware protection, execution of switching commands and serial communication with an external controller. The serial communication from the PEBB to the converter control unit is often realized with plastic optical fibers (POF): the dedicated communication protocol PESNet was developed, running on a 125 Mb/s serial communication line implemented on a Hard Clad Silica optical fiber [25]. The control architecture of PEBBs was formalized in [40], for 1MW+ power electronics. The major scope of the PEBB projects was on standardization of the power blocks, following a system-level approach to the design of power electronic converters rather than on exploiting the advantages of optical communications. The efforts on the communication link were all in the direction of composing multiple blocks to make one single PEC, i.e. synchronization between modules, fault tolerance and plug-and-play features [12],[14]. Dealing with industry applications, the most significant result of the PEBB approach is the AC 800PEC controller from ABB, capable of controlling up to 36 synchronized PEBBs via the proprietary optical PowerLink protocol, with a cycle time of 25 μ s.

One discontinuity with the past is that the priority here is to optimize the use of optical communication for one single PEC, targeting the exploitation of new SiC power modules that allow to have higher switching frequencies at the cost of more severe electromagnetic interference (EMI).

Clearly, the keys to make this idea successful are that the communication protocol must be:

- as fast as possible, to minimize the overhead time required by data transmission and decodification;
- as simple as possible, foreseeing its implementation on a low-cost, dedicated integrated circuit;

3.2 DATA COMMUNICATION IN PECs AND DESIGN OF SHARED CONTROL ARCHITECTURE

Notwithstanding the mentioned examples in the previous section, the use of optical fibers in PECs control continue to be restricted in everyday power electronics, missing to get the new opportunities emerging from new power devices.

This work proposes an original protocol for real-time control of PECs using POF. Accordingly to the recommended architecture for power electronics applications defined by Ericson in [13] and following the directives of the "IEEE Guide for Control Architecture for High Power Electronics" [40], our photonic bus is placed between the switching control (on board of the PEC) and the converter control (off the PEC) as shown in Figure 3.1, in which we highlight our proposed layer's structure. Such a structure allow to have a minimized digital hardware on board of the PEC that is immune to the EMI and can be reused by other PECs. Thus, any real-time controller can be linked via the photonic bus, without design restrictions and problem related to EMI.

In particular Ericson, at the beginning of the 2000s, explained in his works [16], [17] that in order to get integration and modularization of PECs, intelligence and hierarchical embedded control are required into PEBBs. Moreover, different control layers need to be defined. The control architecture on the basis of such PECs is either spatial and temporal. In particular, each PEC has the same basic sections that work mostly in a time as well as spatial domain. These sections are:

1. Gate drive
2. Power switches
3. Power circuit (or topology manager)
4. Application (or load manager)
5. System controller
6. Filters

As depicted in Figure 3.1, gate drives, A/D & D/A conversion as well as the thermal management ranging in the domain that goes from $0.1 \mu\text{s}$ to $1\mu\text{s}$. Modulator and converter switching logic are in

the domain which range is $1-10 \mu\text{s}$. At a slower period the converter control is defined, with a domain greater than $10 \mu\text{s}$ and less than 1ms . The highest layer, in which the application manager is defined, is also the slowest one, having a domain that goes from 1ms to 1s . At last, there is the system control that has in charge of control of the PEC domain.

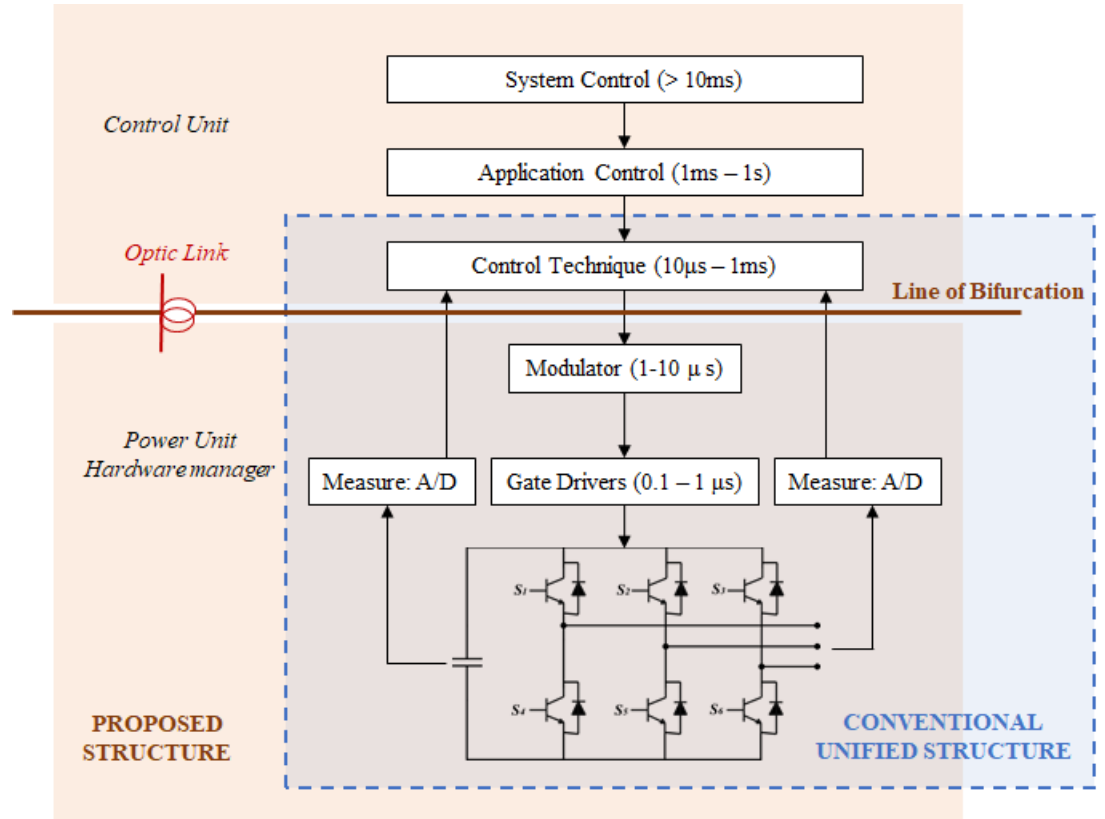

Figure 3.1: Common control layers for a PEC. Conventional and proposed are highlighted

To sum up, data communication in a PEC has been formalized in [40] as reported in Figure 3.1, following the organization by layers typical of data networks (e.g. ISO/OSI). In particular, a generalized control hierarchy boils down to five controllers as follow:

1. Hardware Controller
2. Switching Controller
3. Converter Controller
4. Application Controller
5. System Controller

The *system controller* determines the goals of the power electronic system and manages the working of *application controller* towards

that end. The *converter controller*, placed under the application control layer, can be replaced by a controlled current or a voltage source. The converter controller achieves the functions by setting the voltage references to be forwarded to the modulator (if any) of the *switching controller*. The lowermost layer, i.e. the *hardware controller* handles the power devices.

A relevant example can be a wind farm where the power system operator, i.e. the system controller set the necessary active and reactive power injection into the grid, while the application control layer determines the work of each individual wind turbine, i.e converter layer considering the optimum efficiency, reliability and maintenance.

In the Figure 3.1, it is emphasized that the latter two layers, switching and hardware control layer, are independent of the final application and are common for any PEC. This forms the basis of the replicable and modular PEBBs with minimum on-board intelligence to implementing switching control functions and a communication link to an external controller which, in turn, facilitates distributed control architecture and remote processing. A conventional PEC has a Microcontroller Unit (MCU) on-board for converter control, as shown in Figure 3.1. In the proposed structure, instead, the PEC ends with a switching controller, called hardware manager in [12], and delegates the converter control to an off-board control unit upstream via the optic link.

3.3 AN OVERVIEW ABOUT FPGA AND VHDL

As indicated in [17], all the controller are programmable and multifunctional. However, in order to obtain a completely programmable and Plug-and-Play (PnP) controller, a microprocessor and a programmable logic devices (PLD) have to be used. A PnP controller is extremely advantageous since it permits to all sections of the PEC to be independent of the others. So, Ericson paved the way for the development of low-cost PECs, increasing production considerably. Clearly, the interfaces and the protocol that guarantee the communication between the different layers have to be defined in order to increase their industrial growth, enable range of competitive opportunities and use the simplest set of requirements.

Therefore, before describing the demonstrator that we have built in our laboratory and the communication protocol that manage the photonic bus, a brief background on the FPGAs and the VHDL language and the related software used (Vivado Design Suite) is given.

3.3.1 Field Programmable Gate Array

A PLD is an Integrated Circuit (IC) used in the digital circuits. Differently from a logic gate, that implements a default logic function that

can not be modified, a PLD when it is developed, it is not configured to do a determined logic function, in fact it must be programmed to be used. Thanks to the big developments in the semiconductor industry, PLDs born towards the end of 70's had an enormous growth. The first PLD was the PLA, followed by the PAL, GAL, CPLD and the FPGA.

FPGAs are devices directly programmable (and then re-programmed several times) from the users (*"field programmable"*) off the factory, made of an array of logic components (*"gate array"*) connectible between them, that represents an optimal trade-off between cost and performance. In generic terms, it is an Integrated Circuit which functionality can be programmed by means a hardware description language (HDL) such as VHDL or Verilog. FPGAs make available to the users:

- Logic components such as logic gates (such as AND, OR, XOR), Flip-Flop, buffer and so on;
- Local and distributed connective lines, that are shared by the logic components and give high flexibility.

A generic FPGA's structure is made of an array of logic blocks called CLB (*Configurable Logic Block*), connected to each other through programmable interconnections. Each CLB consists of two or four logic cell that computes boolean operation. Each logic cell have one or more programmable LUT (look-up table). On the edges of the array there are the Input/Output blocks (IOB) that interfaces the CLB with the external circuit. Besides these components, there are the DCM (Digital Clock Manager) to generate the clock signal and the ALU (Arithmetic Logic Unit).

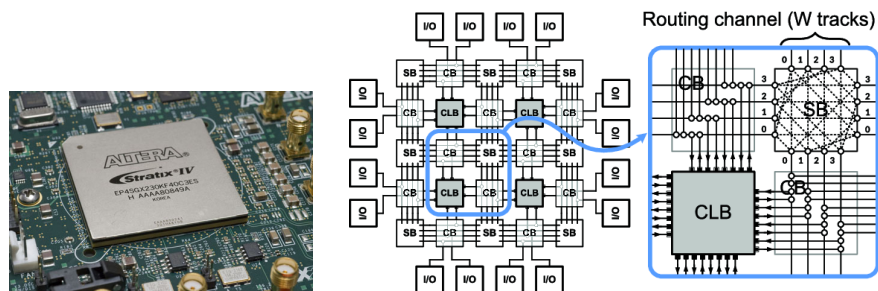

Figure 3.2: FPGA and its CLB representations

The most important advantages of the FPGAs respect to the ASIC (Application Specific Integrated Circuit) is that the functionality to be implemented, is not set by the manufacturer, which can then produce on a large scale with low price. Their generality makes them suitable for a large number of applications such as

- Aerospace and Defense
- High Performance Computing and Automotive

- Wired and Wireless Communications

Being programmed directly by the end user, allow the reduction of design time, verification through simulations and application field testing. Another big benefit over ASICs is that they allow you to make any changes or correct errors simply by reprogramming the device at any time. For this reason they are used extensively in the prototyping phases, as any errors can be solved simply by reconfiguring the device. The design environment is also more user-friendly and relatively easy to learn, such as "Vivado Design Suite" that is an Integrated Synthesis Environment (ISE) produced by Xilinx. On the other hand, for large-scale applications they are uneconomical, because the unit price of the device is higher than that of ASICs (which often have higher design costs).

As can be seen from the Figure 3.3, Xilinx and Altera are the two major manufacturers of FPGAs. The two companies are historical rivals, and together they control over 60% of the market. Both of them provide the related development software for Windows and Linux, in free or paid versions, and with proprietary license. This software allows to program the device and makes it possible to manage the individual resources. In general the different FPGAs manufacturer differ for 3 main aspects:

- General Architecture
- Configurable Logic Block
- Programming Technology

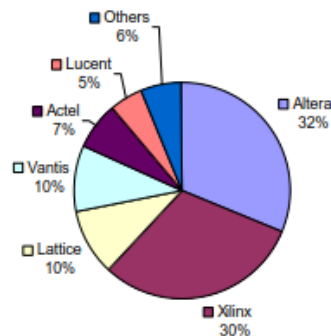

Figure 3.3: FPGAs market

During the last decade, a lot of improvements have been done in the developments FPGAs with embedded microprocessors and related peripherals to build a SoC, i.e. system on a programmable chip. For example, the Xilinx Zynq-7000, shown in Figure 3.4, have a 1.0 GHz dual-core ARM Cortex-A9 32-bit processor embedded within the FPGA's logic fabric. There exist also an alternative to using hard-macro processors, that is the use of soft processor cores that are

directly implemented in the FPGA logic, such as MicroBlaze, a softcore microprocessor designed by Xilinx FPGAs.

This has removed the prejudice that FPGAs are only used as "glue logic" platforms and make the FPGAs a set of system components which can be programmed by the user in order to create a DSP (Digital Signal Processing) system. So, FPGAs became a hardware solution as they offer the capability to develop the most suitable circuit architecture for the computational, memory and power requirements of the application in a similar way to SoC systems.

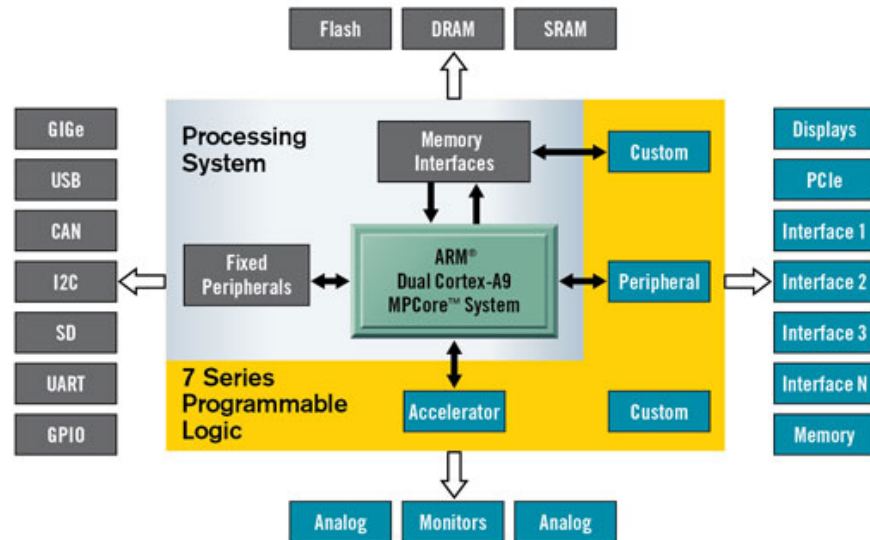

Figure 3.4: Xilinx Zynq-7000 structure

3.3.2 Very-High-Speed-Integrated-Circuit Hardware Description Language

VHDL is, along with Verilog, the most used hardware description language for designing digital systems either for simulation purposes and for synthesis purposes. Its predominant feature is its independence from the hardware technology, that is the capacity to describe whatever digital system without constrain the description to determined real devices. In general, VHDL has five design units:

- Entity
- Architecture
- Configuration
- Package declaration
- Package Body

Indeed, the most used are the *Entity* and the *Architecture* and represent the main phases in the design of a digital circuit. The former

describes the interface and represents a module which may be used as component in a design and define the I/O ports and their type, while the latter describe the behavior and specify what and how the circuit is going to behave. Usually, three different style can be used for the Architecture: structural, data-flow and behavioral. Generally the design of a new device, starts from a behavioral description at High-Level, and then there is the RTL (Register Transfer Level), made of digital fundamental components such as ALU, registers, bus and Finite State Machine.

The last step of the translation of the RTL model in the netlist is automatically executed by a software called synthesizer such as Xilinx Design Suite. It produce a netlist, that is a VHDL file containing instances of cells of the hardware technology (FPGAs) on which the digital circuit is mapped. It is common that during the execution of the design flow, some simulation are executed to check that the congruency between the different behavioral models, RTL and netlist are kept. To launch a simulation, a *testbench* written in VHDL is used. It has the scope to produce the stimuli on the input of the circuit and to check the correctness of the output.

To implement our demonstrator, the integrated design environment (IDE) Vivado Design Suite produced by Xilinx has been used. Being an environment for FPGA produces by Xilinx, it cannot be used with FPGA produced by other vendors. It is a software suite for synthesis and analysis of HDL designs, such as Quartus Prime, the PLD design software produced by Intel. Vivado Design Suite, supported by Windows and Linux operating systems, introduces high-level synthesis respect to its predecessor (Xilinx ISE), with a toolchain that converts C code into programmable logic. Hence, it gives to the developers all the instruments to realize their design.

In particular, it allow the developers to synthesize (compile) their designs, execute timing analysis, observe RTL diagrams, simulate a design's reaction to different stimuli, and configure the target device with the programmer. As shown in Figure 3.5, it is composed by several components, that can be accessed by the Flow Navigator, that allows to the user to initiate and control the entire design flow:

- IP Integrator: It is used to configure a new IP (Intellectuale Property). An IP is a module available in the Xilinx library. It allows engineers to quickly integrate and configure IP from the large Xilinx IP library.
- Simulation: It is a compiled-language simulator that supports mixed-language, TCL scripts, encrypted IP and enhanced verification. It is used for running behavioral and timing simulation;
- RTL Analysis: the register-transfer level (RTL) is a design abstraction which models a digital circuit in terms of the flow of

signal between hardware registers and their logical operations, that create high-level representations of a circuit.

- **Synthesis:** It is the process of transforming an RTL-specified design into a gate-level representation;
- **Implementation:** It includes all steps necessary to place and route the netlist onto device resources, within the logical, physical, and timing constraints of the design.
- **Program and Debug:** It is used to run the design obtained by a successful implementation in hardware by programming the FPGA device and debugging the design in-system;

Another important component is the SDK (Software Development Kit), used for for creating embedded applications on any of Xilinx's microprocessors, such as Zynq-7000 SoCs, or the soft-microprocessor MicroBlaze. The SDK is the first application IDE to deliver true homogeneous and heterogeneous multi-processor design, debug and performance analysis. In our work, it has been used for programming the CPU with a specific C code.

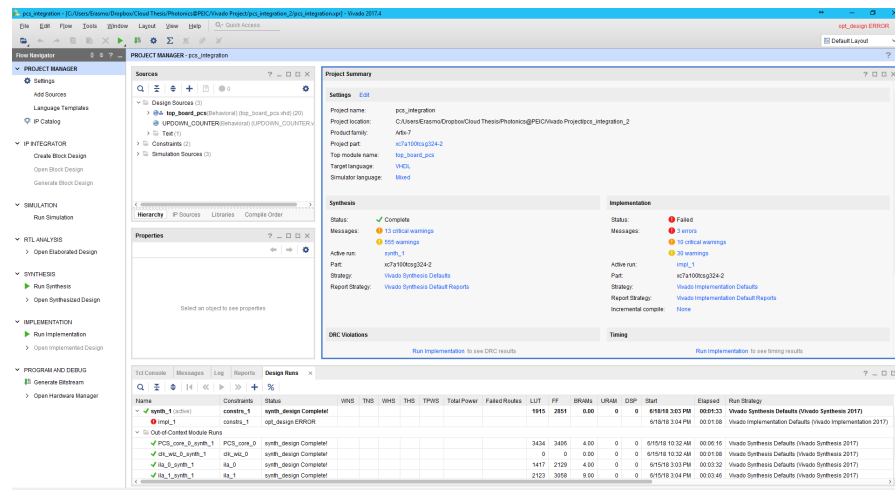

Figure 3.5: A generic Vivado window with the Flow Navigator on the left

3.4 PHOTONIC BUS: IMPLEMENTATION AND PROTOCOL

The photonic bus connects the Control Unit and several PECs configured in a daisy chain through a bi-directional bus made of a fiber pair, as depicted in Figure 3.6, where "downstream flow" refers to the command flow going from the control unit to the PECs while the "up-stream flow" refers to the data stream from PECs to the control unit, while the Finite State Machine (FSM) have been implemented on each node to handle the arrival of the packets. Since commercially available fibers and transceivers are used, a pair of optical fibers are employed (one for up-streaming and one for down-streaming) to link the CU to the first node and each node to the following one. The fiber used are widely diffused, and accordingly are compatible with transceiver optolocks. Also, as the chosen transmission medium is a PMMA POF, it has a refractive index $n = 1.49$. This implies that the propagation velocity in the fiber determining delays is $v = c/n = 2.14 \cdot 10^8 m/s$, where c is the vacuum light velocity.

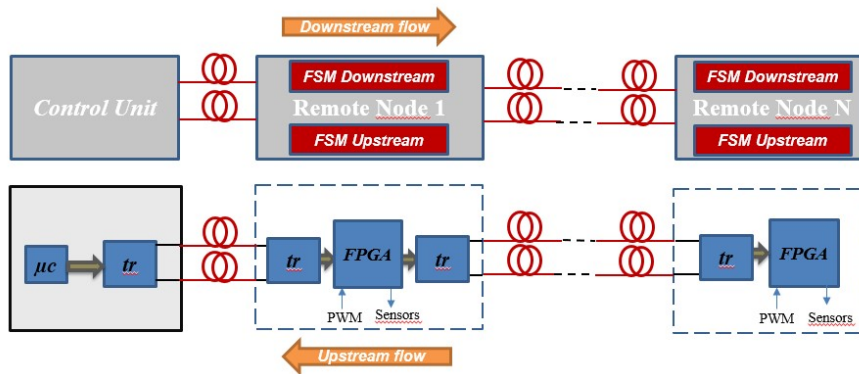

Figure 3.6: Scheme for the proposed TDM control setup based on a daisy-chain connected by POF links

The daisy chain of many PECs is built using two transceivers on each PEC. Both downstream and upstream messages are received, decoded and then forwarded to the next node, down the chain for downstream messages or towards the control unit for upstream messages. Each PEC has its own address in the bus, which is used to correctly receive messages from the control unit or to tag the upstream data sent by the node. Given this decode-and-forward point to point structure, no collision is expected to happen in upstream transmission. Moreover, each PEC has an on-board FPGA to transmit the data from sensors measurements and to implement the received Pulse Width Modulation (PWM) signals from the CU. Clearly, to handle the real time communication between PECs and the CU, the transmission time must be sufficiently low to meet the PWM update rate.

The TDM is realized by means the field "address" of the packet: each node look at the channel to check if it is free before transmitting,

but unlike a standard TDM where a collision cause a fail of the whole system, here there is not a destructive collision since our system use buffers that allow to the node to know if the bus is free or not. Network using standard TDM are PON or Wi-Fi, and they use a shared medium while in our demonstrator the medium is not shared, since a point-to-point communication is used, this means that each node handle its piece of fiber. However, the problem is present only during the upstream phase, while during the downstream phase in which only one node speaks there is no problem. So in the last case, it is impossible that two packets are transmitted at the same time, since the CU when receives a packet, elaborates it and then will be always the CU to decide when send them. Hence, to be as a standard PWM, a synchronization between the nodes is needed, while until now the synchronization mechanism is: each time the the PWM is updated, a node sends a packet and wait an answer. Clearly, if this mechanism doesn't work, the motor will not work.

3.4.1 Protocol Description

In Figure 3.7, the timing organization of the sampling and switching task are shown. The switching frequency of the power devices, that are on the order of 10 - 20 kHz, set the sampling and switching period of the PEC. This is marked as T_{PWM} in Figure 3.7, although not necessarily meaning that all PECs use Pulse Width Modulation. In our case it is fixed at $100 \mu s$, this implies a switching frequency of 10 kHz. T_{PWM} indicates the frequency of the communication on the bus, i.e. the frequency with which PWM is updated; also it represents the amplitude of the waveform used to control the PEC. It has been chosen equal to 10 kHz, since for a single time step should be sufficient to encompass the processing time and transmission time.

The timing diagram displays the transfer of a packet from the remote node to the control unit and its response. It can be observed that during the upstream phase, at the trigger, that is at $t(k)$ the current flowing in the inverter legs is sampled by the AD converters on the power unit (remote node) and is ready to be sent to the control unit. The Analog-to-Digital Converters (ADC) measures currents and voltage on the bridges. The time needed to send (T_{encode}) and receive the packet (T_{decode}) corresponds to the time needed to compute the parallel to serial and serial to parallel conversion of the 66bit words used by the 64/66b line code adopted, plus the protocol encoding and decoding overhead and the latency introduced by the clock and data recovery logic. The packet flows through the intermediate node in the daisy-chain structure before reaching the CU. At each node, the packet is processed to check for the target identifier. T_{prop} is the propagation time of the light along the optical fiber. Next, some time ($T_{control}$) has to be reserved to the algorithm execution in the micro-controller of the

CU, that is to the computation time of CU to process the measured data, preparing them to be loaded in the PWM, and to determine the future states of the inverter, while some idle time (T_{guard}) at the end of the cycle is needed to guarantee that the new PWM values are correctly updated at $t(k+1)$ before the next cycle starts. The overall transmission time (T_{transm}) is defined as one-way total time to pass the data packet from one node to the other.

New duty-cycle value is expected at each PWM cycle for optimum control, so deterministic latency is needed. In order to obtain the

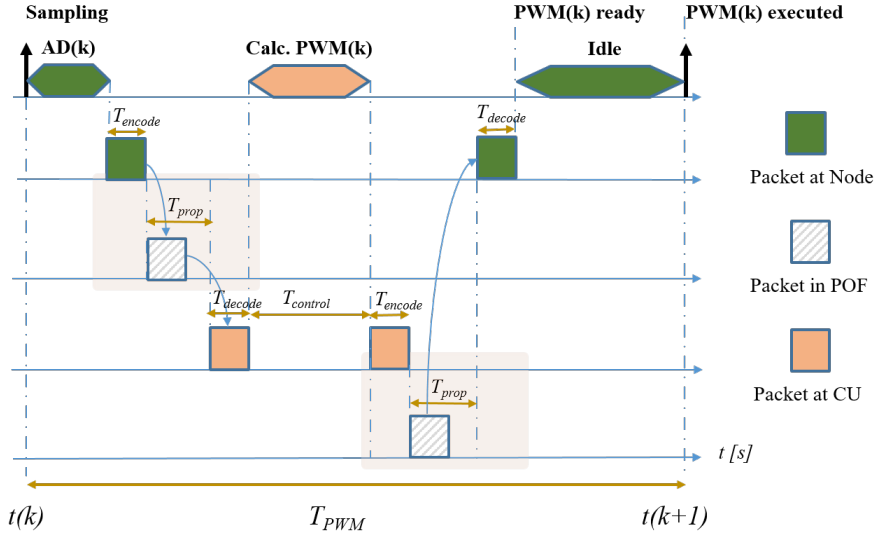

Figure 3.7: Communication cycle timing diagram of the proposed optical link

timing results, useful to have an idea of the behavior of our optical link, the following formula have been used:

- Propagation time: $T_{prop} = L/v$
- Time needed to send and receive a packet: $T_{encode} = T_{decode} = Packet_length/R_b$
- One-way total time to pass the data packet from one node to the other: $T_{transm} = 2 \cdot T_{decode} + T_{prop}$
- Maximum number of devices that can be controlled: $N_D = (T_{PWM} - T_{control}) / (2 \cdot T_{transm} + T_{guard})$

The packet length of 132 bit was considered also accounting for overhead; R_b is fixed at 250 Mbit/s; $T_{control}$ is considered equal to 30 μs and T_{guard} is fixed at 2 μs . Figure 3.8 shows the behaviour of the transmission time against the variations of three parameters namely length of the fiber, bit-rate and computational time. Clearly, the guard time between two packet is taken into account only for a TDM scheme and not for a one node scheme. For each parameter variation, the

other specifications are maintained at their optimal value: $L = 40m$, $R_b = 250Mbit/s$, $T_{control} = 30\mu s$, $T_{PWM} = 100\mu s$ and $T_{guard} = 2\mu s$. As

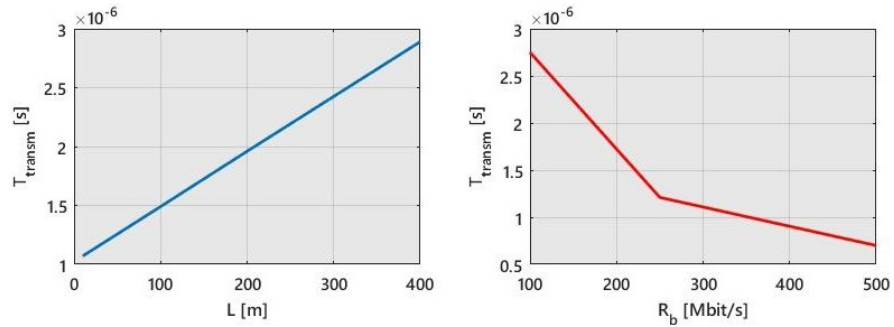

Figure 3.8: Sensitivity of T_{transm} to fiber length and bit-rate in a one-way transmission between two nodes

depicted in Figure 3.8, increasing the length of the fiber, transmission time also increases. It must be pointed out that the additional time arises from the increase in the propagation time within the POF. Also, given the optimal conditions, for $L = 40 m$, the upper limit of number of remote nodes is $N_D = 15$ and increasing the distance L to 400 m decreases the N_D to 8. Regarding the R_b variation, the bit-rate determines T_{encode} and T_{decode} for a given length of the packet. An inverse relation is observed with the transmission time. Also, at 250 Mbit/s, $N_D = 15$, while decreases to 9 at 100 Mbit/s and increases to 20 at 500 Mbit/s.

In Figure 3.9, the simulation of the packet flow on the bus obtained with the Vivado Design Suite, is shown. It can be seen that after the PWM trigger there is the AD conversion; after the sampling, the packet is built and it is immediately transmitted on the photonic bus and received by the control unit.

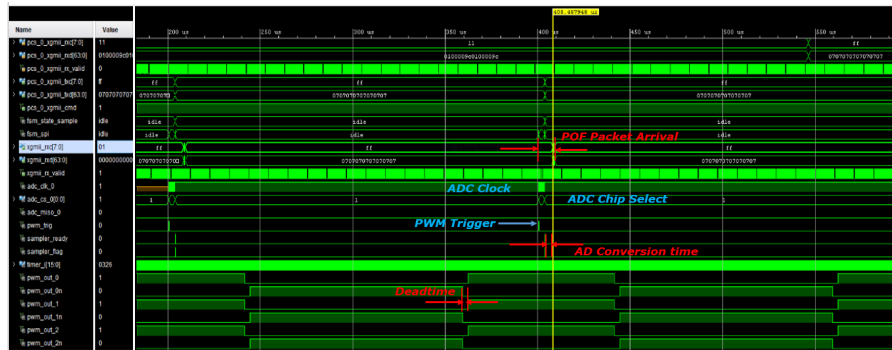

Figure 3.9: Simulation timing diagram with Vivado

3.4.1.1 Packet structure

To sum up, although not explicitly optimized for, the proposed protocol is already capable to manage 10+ devices in real-time using time-division multiplexing, with a distance of 40m between each node. In particular, in optimal conditions and with the values specified before for the various parameters, we are able to manage up to 15 devices. Respect to a standard PEC control scheme, having the micro-controller on board, the optical communication adds a time overhead equal to two transmission times ($2 \cdot T_{transm}$). Therefore it is extremely important that the transmission time is as negligible as possible, that is in the order of $1 \mu s$, respect to the switching period. In the Figure 3.8, the ideal protocol performance are depicted, achieved considering only the bit-rate (R_b) of transmission and the propagation time of light in the POF, without taking into account implementation dependent latency overheads.

Our transmission protocol is based on 132bit packets, shown in Figure 3.10, and transmits and receives two packet types. The protocol is encoded as a couple of consecutive 66 bits words: the first word is tagged as /START (Block field type 0x78), while the second is tagged as /STOP (Block field type 0xFF), so each packet is able to carry up to 14 bytes of payload. The 66b sync header is always set to "10", i.e. control + data words. The contents of each packet is different depending on whether it is an upstream packet or a downstream packet:

- Downstream packet: Source node identifier (address), 3-phase PWM signals (commands) in the fields Data 0/1/2, (optional) telemetry/diagnostic in Data 3/4/5, status word.
- Upstream packet: Source node identifier (address), 3-phase current feedback (ADC sample data) in the fields Data 0/1/2, quadrature encoder for mechanical rotor position in Data 3 and (optional) telemetry/diagnostic in Data 4/5, status word.

As depicted in Figure 3.10, of the 14 bytes of payload, the first byte contains the node address in the daisy chain (destination in the downstream from CU to PEC, or source node in the upstream from the PEC to the CU), while the last byte (i.e. status/debug byte) is used to read/set discrete I/O pins present on the node itself, in fact it has been used to measure the latency on the channel. The remaining 12 bytes, i.e. the 96 bits of useful data, are organized as six 16 bit words. They contain ADC sampled data and the position (value that depends by the encoder of the motor) in the upstream channel and PWM duty-cycle values for the downstream. Further extensions of the size of the packet must consider the rules of the line protocol, so they can be done adding 64 bit data words (66 bits when coded, marked with header 0 1) between START and STOP frames. When data packets are

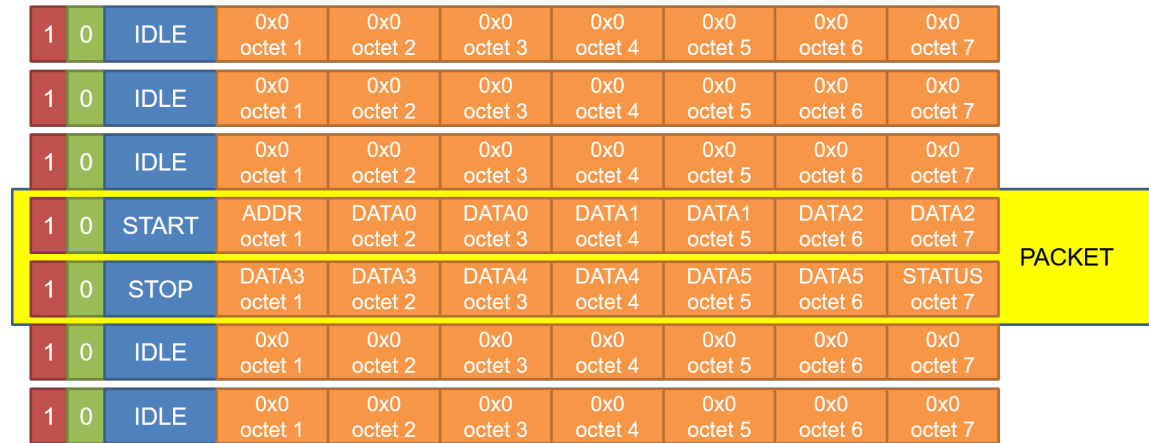

Figure 3.10: Example of packet flow

not transmitted (most of the time), the channel is filled with /IDLE words (Block Field 0x1E).

3.4.2 Implementation

To build our demonstrator, in addition to the timing requirements explained previously, the total cost and the relatively short fiber distance requirements are also considered. Accordingly, we opted for an integrated, tool-less and commercially available transceiver, that has been linked to a differential I/O pair of the FPGA board. In fact, the optolock design permits for setting a connection by just cutting the fiber ribbon with a pair of scissors and locking it into the correct position.

As short distances are targeted, POF optical bandwidth does not deteriorate received data. Therefore, it is not necessary to reconstruct the transmitted waveform using A/D conversion and filtering implemented in Digital Signal Processing (DSP) [31], but only an hard detection is implemented to keep cost and complexity low. As described in Chapter 2, the fiber is a simple PMMA plastic fiber, standardized as A4a.2. We have also seen that it has a large core diameter ($980 \mu\text{m}$) covered with a thin ($10 \mu\text{m}$) layer of cladding, so it can be deployed without using specialized tools, but it has two main disadvantages, a large attenuation (180 dB/Km using red light at 650 nm , such as the one used by the transceivers we have chosen) and a low bandwidth length product (about $40 \text{ MHz per } 100\text{m}$ or about $80 \text{ MHz per } 50\text{m}$), which limit the possible maximum length and the maximum data rate.

The strict real-time requirements impeded to relying on a Forward Error Correction (FEC) code as the Reed Solomon $237,255$ used in [31], limiting the link length to the 40m at 250Mb/s declared by the transceiver manufacturer. Also, the use of the FEC will increase too

much the latency, and since we would work with higher switching frequency we must reduce the latency more.

In order to successfully manage the optical channel, both DC balancing and an adequate data transition density are needed: these requirements are fulfilled by adopting a line code such as the 64/66b that allow us to have a correct clock recovery introducing transitions at some time. The clock recovery is needed since in the used scheme there is not a remote clock that is synchronized with the local clocks, but each node has its own clock with its own frequency. Moreover, the transition density and the DC balancing are randomized by scrambling the data and control words with a known polynomial before optical transmission.

The code implemented in Vivado to handle the photonic bus is already designed to be used for a system having more than one PEC. In this architecture the CU connects to the first node in the chain and the connects in daisy-chain to the other. In this way, a great amount of fiber is saved. If this kind of topology will not work, a new one such the star topology will be used. Moreover our protocol is designed so that the micro-controller on the CU is idle all the time waiting for the packets, while the PU (hardware) checks continuously if there are packet on the bus.

3.4.2.1 64/66b line code

64b/66b is a line code, used in data transmission, in which 64 payload bits are encoded as a 66-bit line code, giving quite state changes to permit proper clock recovery and alignment of the data stream at the receiver. It was defined by the IEEE 802.3 working group as part of the IEEE 802.3ae-2002 amendment which introduced 10 Gbit/s Ethernet, with several goals such as lock recovery, stream alignment, DC balance, transition density and run length. It is widely adopted because it has a low overhead, enabling in this way a more efficient data transmission. The protocol overhead of a coding scheme is the ratio of the number of added coding bits to the number of raw payload bits. In particular, the 64/66b line code demands a 2 bit overhead over 64 bit words with a limited 3% overhead, that is much smaller than the overhead of the 8b/10b encoding scheme, which add 2 coding bits to each 8 payload bits, reaching an overhead of 25%. The 66 bit word, is made by prefixing one of two possible 2-bit preambles to the 64 payload bits

- If the bits in the preamble are 01, 64 payload bits are data.
- If the bits in the preamble are 10, the 64 payload bits hold an 8-bit *Type Field* and 56 bits of control information and/or data

The use of the 01 and 10 preambles ensures a bit transition every 66 bits, which means that a continuous stream of 0s or 1s cannot be valid data. It also permits easier clock/timer synchronization, as a transition

must be seen every 66 bits. The preambles 00 and 11 are not used and indicate an error if seen.

The 64-bit payload is then scrambled to guarantee that a quite even distribution of 1s and 0s are found in the transmitted data. Generally, the encoding and scrambling are implemented completely in hardware, with the scrambler using a linear feedback shift register. The 64b/66b encoding scheme is applied in several technologies:

- InfiniBand
- Aurora, from Xilinx
- 10G-EPON, 10 Gbit/s Ethernet Passive Optical Network
- 10 Gigabit Ethernet (most varieties)
- 100 Gigabit Ethernet

3.5 DEMONSTRATOR SETUP

As explained in Chapter 2, our demonstrator, shown in Figure 3.11, is able of controlling a permanent magnet (PM) based brushless servomotor via a three-phase voltage source inverter (VSI), as presented in [43]. It uses a Xilinx Artix-7 100T FPGA and integrated optical transceiver for ease of development. The goal of this work is to get a standardized, dedicated integrated circuit, with the possibility to be used in PEBBs, i.e. in the composition of multiple converter modules as building blocks such as a multi-level converter architectures with distributed control. Hence, one foreseeable application is in the field of real-time hardware for development of PECs control. Key players in this field [42] would benefit from a standardized optical interface for commanding PECs, both for rapid prototyping and HiL.

The power unit (PU) was built around a commercial mini-module with a Xilinx Artix-7 100T FPGA, an integrated optical transceiver and two 2.54 mm spaced expansion slots. The two units are linked by a 40 m POF pair and handled to control a three-phase VSI, used for vector control of a brushless servomotor. The servomotor is rated at 100 W and 3000 rpm, while the PEC driven it is a 3-phase 2-level VSI which is the X-Nucleo-IHMo8M1, a 60 V DC input, 15 A AC output expansion board for STM32 Nucleo boards by ST-microelectronics. The PEC and servomotor are voluntarily off-the-shelf equipment and of small size, since the main objective of this work is on demonstrating the real-time control ability via POF.

Indeed, a custom adapter print circuit board (PCB), replacing the STM32 Nucleo Board, has been developed to link the FPGA module to the X-Nucleo-IHMo8M1 expansion board and to a second optical transceiver to daisy-chain more units. It is better shown in Figure 3.12.

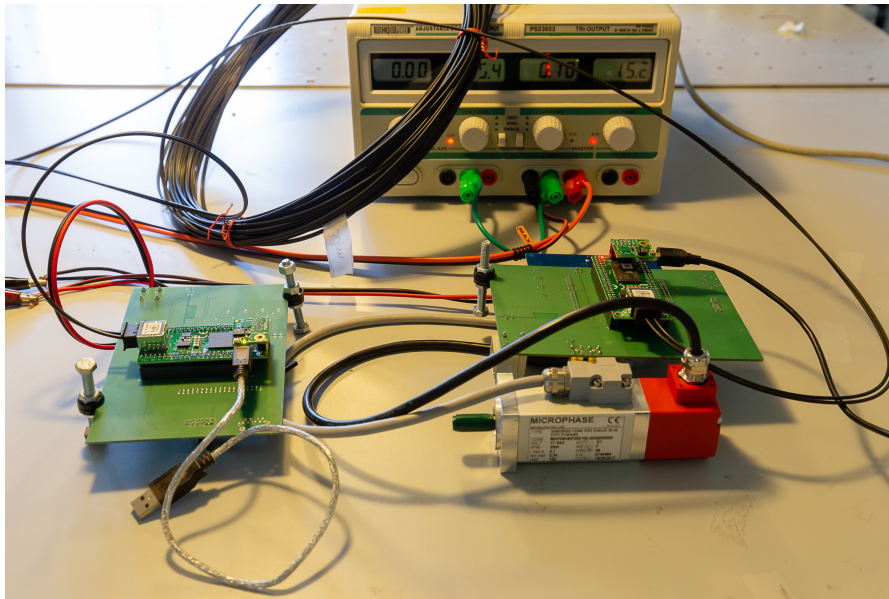

Figure 3.11: Demonstrator Setup

Being a three-phase VSI, each PCB has three AD converters to measure the current generated by each leg of the inverter, also there is another general ADC that measure the incoming voltage. In addition, each node has on its own PCB an encoder that give information about the speed of the motor and its direction. Also, on each power unit, two PCs (Physical Coding Sublayer) handling the ADC sampling and the PWM update, and the SPI act to communicate with the ADCs and handle the serial to parallel and parallel to serial conversion (since the micro-controller and the ADC work with 16/32 bits words while the adopted line code works with 66 bits words) are implemented to manage the incoming and outgoing packets.

The remote node receives 6 gate signals (3 + 3 complementary) from the Control Unit and enforce it on the inverter. Next it sends the measured quantities (3 line currents + DC link voltage) to the CU. In addition, process the encoder signals (A, B, Z) and transmit the counter value to CU. Hence, this unit run in continuous state unlike the CU as the gate signals must read at high frequency for better PWM resolution. Regarding the ADC, though they may be transmitted continuously by PU, they are received only at discrete 10 kHz by CU. But since the two units do not have a common clock and considering the transmission latency, it is better to have the continuous transmission. Lastly, a deadtime (T_{guard}) is enforced on the gate signals so that, between the switching transmission of two IGBTs of the same leg, a small time lapse is desired from one switch turning off and the other turning on to prevent short circuit at transients.

For the control unit (CU) the same mini-module, a Xilinx Artix-7 100T, as the remote node has been utilized, but this time instantiating a full Microblaze micro-controller with built-in floating-point unit running at 100MHz, as shown in Figure 3.13. Clearly, on the CU the PCB is not needed since it just send commands to the nodes based on the micro-controller operations. In the Figure 3.13 the block diagram of the control unit, obtained by the simulation run with Vivado Design Suite, is depicted. All their components are shown such as the PCS to handle the incoming packets and another PCS to handle the outgoing packets towards the nodes, the UART for the debug, PWM signals for handling for motor speed and the MicroBlaze micro-controller.

To process the received quantities from PU (3 line currents, DC voltage, encoder) and generate the PWM gate signals for the next time step, 3 channel PWM (& 3 complementary channels) with a common carrier signal and a PWM interrupt routine at bottom of the carrier (triangle wave) are required.

Finally, respect to the works presented previously such as [19], here we don't have a FPGA for each leg of the motor, but our FPGA control all the three legs of the inverter, obtaining in this way a less bulkiness system.

In the following table, the occupation of the Xilinx Artix-7 100T, reported by Vivado Design Suite, for the power unit and the control unit is reported. Since the occupation is extremely low respect to the available resources, a simpler FPGA can be considered, reducing in this way the device cost.

Table 3.1: Power unit occupation

Resource	Utilization	Available	Utilization percent
LUT	8024	63400	12.6
LUTRAM	341	19000	1.8
FF	11084	126800	8.7
BRAM	8	135	5.9
IO	34	210	16.2
MMCM	1	6	16.6

Regarding the code that control the motor, it has been written using standard C language, compiled by Xilinx SDK, and run on the soft core Microblaze. Being a C code, it will be simply recompiled when targeting other devices, following the idea of PECs, that is changing the control code, several application can be exploited, holding at the same time the same hardware structure. It has a small footprint (a few KB of RAM) and it can be executed from the embedded BRAM blocks present on the Artix-7 100T FPGA.

As the control flow of the code, it is the following: once the PWM interrupt is generated, within the interrupt routine function, the data from PU is read from the optic bus. The motor control algorithm would be a simple vector control (with a couple of PI regulators, not memory demanding) that gives the duty cycle of the 3 PWM channels. Usually, it is updated at the end of the PWM period. Upon conclusion, the interrupt routine is exited and the control returns to the main

Table 3.2: Control unit occupation

Resource	Utilization	Available	Utilization percent
LUT	13036	63400	20
LUTRAM	1047	19000	5.5
FF	14700	126800	11.5
BRAM	35.5	135	26.3
FLOATING POINT UNIT	6	240	2.5
IO	24	210	11.4
MMCM	1	6	16.6

where it either remains idle or does supplementary activities such as telemetry/monitoring etc.

In other words, the control strategy is a closed loop field oriented control consisting of an outer speed control loop and an inner current control loop, while the linear regulators of the loop are tuned based on the motor parameters to guarantee sufficient stability margins and desired bandwidth.

However, as the focus here lies in exploring the feasibility of POF integration to PEC in order to obtain a generic solution independent of the application, the end application and the level of complexity of the control code is irrelevant.

3.5.1 *Finite State Machine*

As can be seen from the Figure 3.6, each power unit has two FSMs, one for handling the downstream flow and another one for handling the upstream flow, while on the CU there is the MicroBlaze micro-controller that by means the C code takes care of the received packets. In particular, as soon as a packet is received, an interrupt is raised and the micro-controller can access those values on five registers, memory mapped on a known location on the system AXI bus. Once the computation algorithm is completed, the updated PWM duty cycle values are written on the registers of the transmit section and the downstream packet is ready to be sent to the target node.

The FSM implemented to handle the upstream flow is shown in Figure 3.14. This FSM takes care of the ADC sampling. Generally the PU is in the IDLE state, then if the flag "sampler" goes to 1, it means that sample data of the node itself are ready, so a packet made of 2 words of 66 bits is created and transmitted to the control unit; after the transmission the power unit come back in the IDLE state; otherwise, if the flag "enable" goes to 1, it means that the node is receiving from a lowest node (it is a valid packet, but it is not for him), so in this case the packet (two words of 66 bits) is simply forwarded towards the CU and then in the "wait" state it attends to finish the transmission before returning in the IDLE state. Clearly, if the flags are not 1 and no packets are received, the power unit remains in the "IDLE" state. The FSM implemented to handle the downstream flow is shown in Figure 3.15. This FSM takes care of the PWM update; the PWM values are written in temporary registers, internal to the power unit, and then are updated at the sampling time. Generally the PU is in the IDLE state. When a packet is available (flag "enable" is 1, the address of the received packet corresponds to the address of the node, the received packet has the frame "START") PWM are updated; then the PU goes into the "wait" state (i.e. a cleaning state after an update operation) where attends to finish the transmission, before returning in the IDLE state; otherwise, if the flag enable is 1, the received packet has the

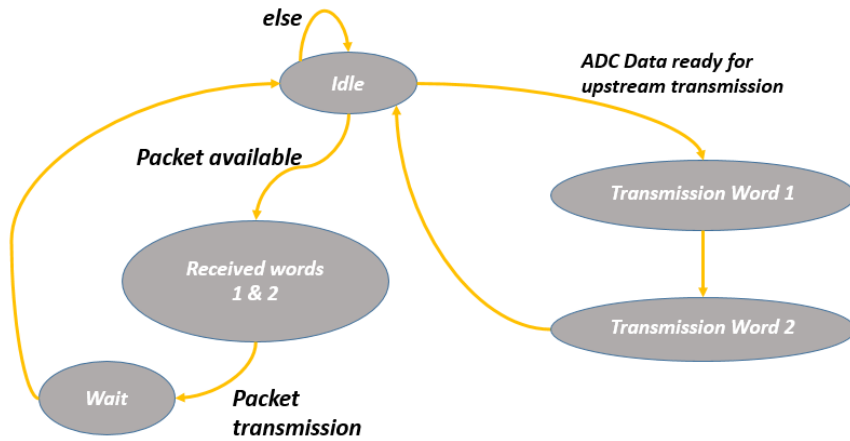

Figure 3.14: Finite State Machine - Upstream flow

frame START, but the address doesn't correspond to the address of the node, the packet is forwarded towards the next node, and, as in the previous case, there will be a "wait" state before returning in the IDLE state. Clearly, if enable is not 1 and no packets are received, the power unit remains in the "IDLE" state.

The flags are needed because the power unit works with a speed much greater respect to the available data on the bus, so it must be kept hold until a word of 66 bit arrived.

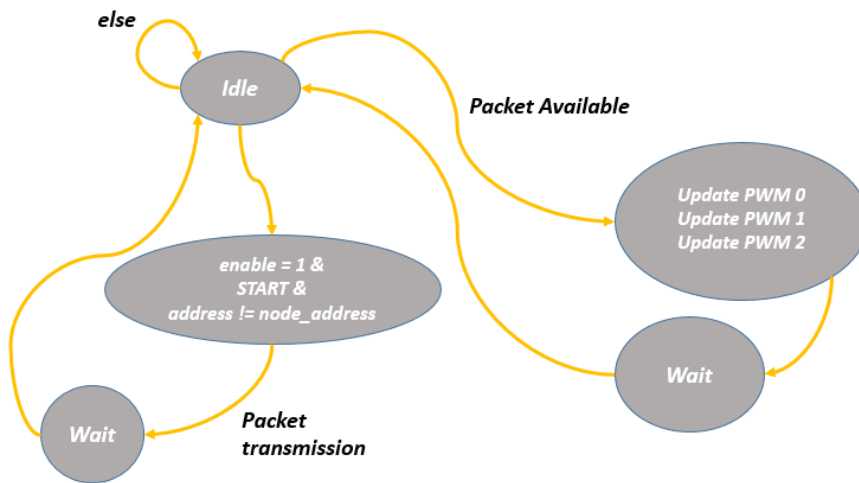

Figure 3.15: Finite State Machine - Downstream flow

3.5.2 Experimental Results

The first tests have been executed sharing a single clock all over the network to synchronize transmitters and receivers. Verily, each node has its own internal clock with its own frequency and will ask data to the master only when it need for them. So, either clock recovery and

data recovery section have been implemented to each of the nodes and on the CU to manage the small frequency differences among the physical frequency of the clock and the nominal one, adopting from the literature a completely and well-established digital solution able to recover all the incoming bits, i.e. the lightweight and scalable 4X oversampling for asynchronous data. Accordingly, incoming asynchronous data stream is oversampled at 4X its nominal rate, that is at 1 Gbit/s ($250\text{Mbit/s} * 4$) and the recovered bits are inserted in a FIFO, deep enough to take into account for small clock variations and jitter. Nevertheless, this solution involves a undesired effect: the receiver FIFO that moves data from the asynchronous clock domain to the internal system clock, can get an underflow (the clock on the receiver is slightly faster than the transmitter) or an overflow condition (the clock on the receiver is slightly slower than the transmitter). The frequency mismatch results in a different number of transmitted/received words between the packets. The control logic solves this situation by adding/removing an IDLE word after the descrambling section of the 64/66b decoder. This operation is safe because the optical bus is principally loaded with IDLE words with only occasional data packets. This happens because in order to maintain low latency, a high bit-rate is used. So, we have a large available bandwidth but with small amount of available packets. In other words, DATA packets will be much less than IDLE packets since, being the switching frequency T_{PWM} 10 kHz and 132 the length of a packet, the bit-rate with which the motor supplies data will be $R_{b-motor} = 10000 \cdot 132 = 1.3\text{Mbit/s}$, that is less than 1% respect to the bit-rate available on the fiber, i.e. 250 Mbit/s.

Since our demonstrator deals with a real time control system, the performance bottleneck is not the available bandwidth (small amount of the bandwidth will be occupied, since the fiber is usually in the idle state), but the total latency. For this reasons, we mainly focused our attention in reducing the latency, i.e. the transmission time of a packet between two nodes. During the first trials made with the simulator implemented in Vivado Design Suite, the latency of the system was about 8 μs . In order to further decrease the latency, the code has been slightly modified, changing the logic that handle the read/write of the FIFO: the amount of words stored in the FIFO has been minimized, since each stored word bring a latency of 64 bit, i.e. 0.25 μs . After these improvements, we managed to get a latency of about 4 μs , as depicted in Figure 3.16, where the latency is 4.66 μs .

In Figure 3.16 is shown the global simulation of the transmission of a packet from a generic node to the control unit, and is also possible to see the state of the FSMs. As can be observed, after the AD conversion (sampler_flag is high), data are available and then they are immediately transmitted (white cursor) and after 4.66 μs are received from the control unit (yellow cursor). Subsequently, in order to validate the

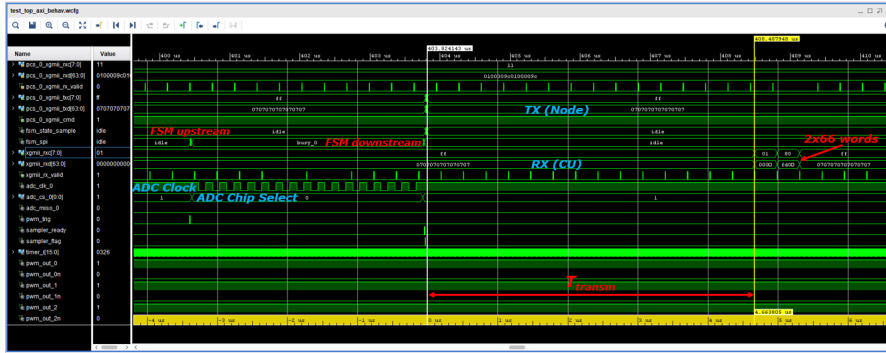

Figure 3.16: Measured latency with Vivado simulator

simulated latency, we measured it with the demonstrator built in the laboratory. In particular, to run our demonstrator we use a HQ-Power PS23023 power supply and a Tektronix TDS3054C oscilloscope.

Practically, to estimate the latency on the channel, two pins, one on the PU and one on the CU, are moved. The C code running on the control unit sets a pin on the control board and immediately sends a packet (using the field "status" of the packet) with the instruction able to raise the pin "status" on the board; using the oscilloscope we measure the time between the rising edges of the pins of the two boards as depicted in Figure 3.17.

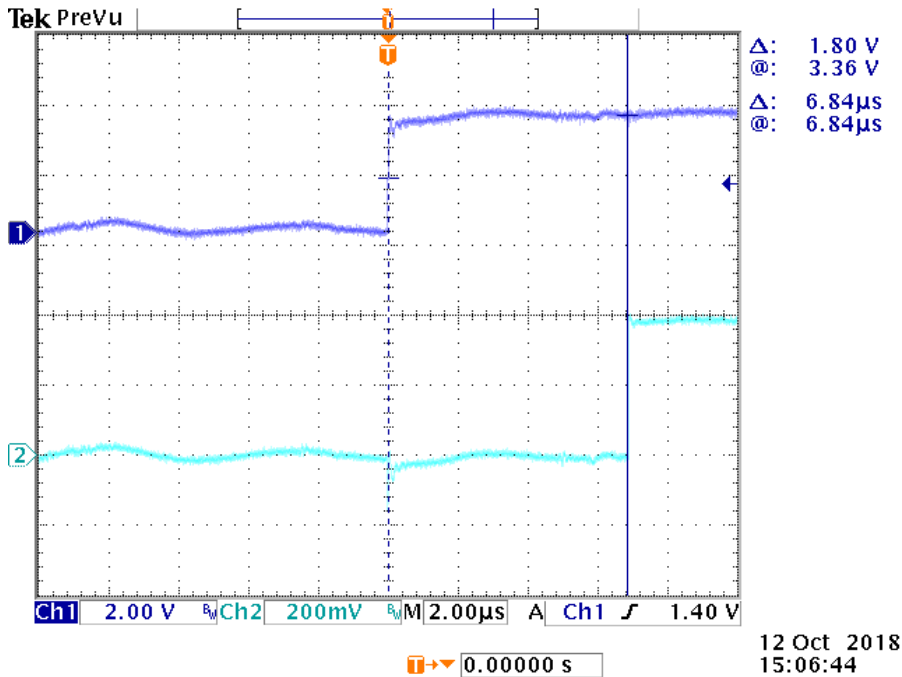

Figure 3.17: Measured latency with the oscilloscope

As we can see, the measured latency is slightly different from the simulated values and it is equal to $6.84 \mu s$ but at the same time confirm and validate the simulation made with Vivado. The reason of this little difference between the simulated and the measured latency is due to

the fact that the clock recovery introduces some delays that can not be perfectly simulated since they depends mainly from the physical quartz that are on the boards.

However, the measured latency is quite near to the value predicted with the formulas presented in the previous section, that is $1.2\mu s$. In the future, some more improvements can be done to reduce the latency, but to get closer to $1.2\mu s$, new technologies such as new transceivers and new fibers must be used, and also a line code with higher performance and lower overhead.

TOWARDS THE INTERNET OF POWER: CONCLUSION AND FURTHER DEVELOPMENTS

“Electricity changed nearly everything about the way we live and work—and that scale of transformation is possible with the Internet of Things.”

Ian Goldin, Director of Oxford Martin School, University of Oxford

Today, people are living a new revolution. The twentieth century, the so-called "miraculous century of physics", with the incoming new technology has heavily changed our daily life. As just explained in the first chapter, one of the most important field of this revolution is due to the improvements in the field of power electronics exploiting the power of the electricity that has brought to an explosive growth of electronic devices as well as new methods of control them. Moreover, another important field of this revolution is the development of the "Internet" that has not only made our life more interesting and livable, but has created new industries and new methods to handle and share information by means the cloud technology.

As the world becomes increasingly energy aware and industries worldwide have a renewed focus on energy efficiency for electric motors, new methods are emerging at the component and system levels of industrial motor drive design concerning power, size, performance, reliability and safety. Modern motor drives are expected to drive more current while delivering high efficiency, reliability and accuracy with optimal high voltage protection.

Hence, driven by the great amount of possibility offered by the power electronics world, we focused our work on the using of plastic optical fiber to link and control several power devices in daisy-chain scheme, joining together the "Optical world" and the "Power world". Also, the Internet of Things paradigm and the ubiquitous diffusion of Power Electronic Converters in many fields of application are suggesting the possibility of new ICT services associated to advanced power conversion.

In this chapter an introduction about the Internet of Things and its link with the power sector is given, and also the State of the Art on the Internet of Energy is presented. Finally, the conclusion and the main aspects of our work are summarized and further improvements are introduced, highlighting the cloud approach for controlling power electronic converters.

4.1 INTERNET OF THINGS: AN OVERVIEW

It is undoubtedly true that one of the most important and significant change of our history is due to the three industrial revolution that are strongly modified our way of life: in the first industrial revolution bring important benefits in the productivity using steam and water; in the second one there was the electricity and assembly lines; in the third one the computerization. Nowadays the fourth industrial revolution is in act and regards the Internet of Things (IoT), which exploits Internet and computer networks to link machines, appliances and people. Some years ago, the Institute of Electrical and Electronics Engineers (IEEE) gave the definition of IoT as:

"An IoT is a network that connects uniquely identifiable 'Things' to the Internet. The 'Things' have sensing/actuation and potential programmability capabilities. Through the exploitation of unique identification and sensing, information about the 'Thing' can be collected and the state of the 'Thing' can be changed from anywhere, anytime, by anything."

The "things" represents the nodes of the networks, having a unique address in order to send and receive data from the other objects of the networks while the sensors are linked with the "thing" making it smart.

The main reasons of the IoT explosion in the sensor and control system, AI and communication technologies is due essentially to few factors:

- The growth of power electronics that allowed the development of cheap and high power chips like wireless chipset, and powerful sensor such as cameras, temperature and sounds;
- Standardization in communication technologies, i.e. the definition of different standard in the communication world like 3G, 4G and 5G for cellular networks, or TCP/IP protocol for computer networks;
- Standardization of software technologies that have brought important benefits in artificial intelligence, cloud computing and cyber-security. For example, today nearly all smartphone have the voice recognition-based virtual assistant (Google Assistant and Siri), face recognition; also cloud technology is more and more used by companies of several sectors since it provides high efficiency, cost reduction for the services management

A general IoT architecture is depicted in Figure 4.1. As we can see, at first data are collected with sensors from the different devices that generate real-time data; these data are aggregated and sent to a gateway device that forward them to the IoT hub. The IoT hub takes

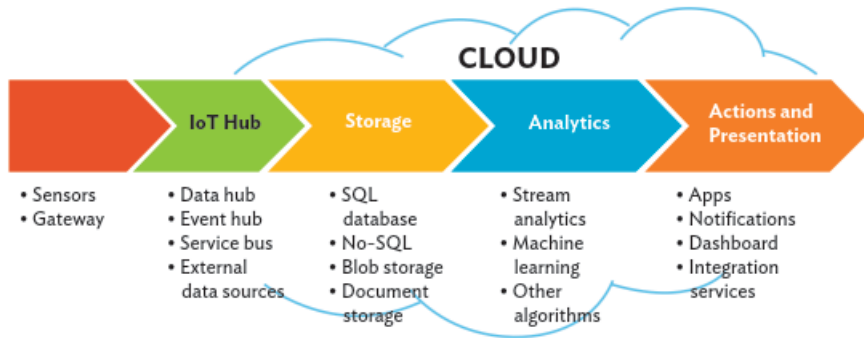

Figure 4.1: Components of the IoT cloud

care of security, i.e. identity management, authentication and data decryption and/or encryption. After, there is the "storage step", where the dataset is stored with a suitable method; during the "analytics" step data are processed with different algorithms such as stream analytics or machine learning; finally, in the last step of the IoT cloud there are the possible applications and actions.

4.2 INTERNET OF ENERGY: INTERNET OF THINGS IN POWER SECTORS

One of the early version of IoT in the power sector was in the 1990s with the supervisory control and new data acquisition methods through the PLC (Programmable Logic Controller) in order to automate industrial processes. The PLCs collect data, analyze them, and then send commands to control the handled process. Another example can be the smart meters that can distribute real-time consumption data and link customers.

Internet of Energy is a modern idea resulted from the enormous developments in the power devices and the communication technologies, that in the last period is attracting important attention in different fields such as universities and government [50],[51],[52]. The main goal of IoE is to make the energy clean and green by using the enormous amount of energy produced with the renewable sources. The principal reason for which the use of renewable sources, during the last two decades, is steadily increasing is due to the significant developments in the technology, leading to a constantly decreasing of their usage cost. There exist several forms of renewable like wind, solar, geothermal, biomass and hydroelectric. For example:

- Wind source: Electricity is produced by intercepting wind energy by means the wind turbine; the output power depends on the greatness of the wind turbine and wind speed.
- Solar power: The solar energy is a plentiful source of energy in the earth; the electricity is produced with the photovoltaic

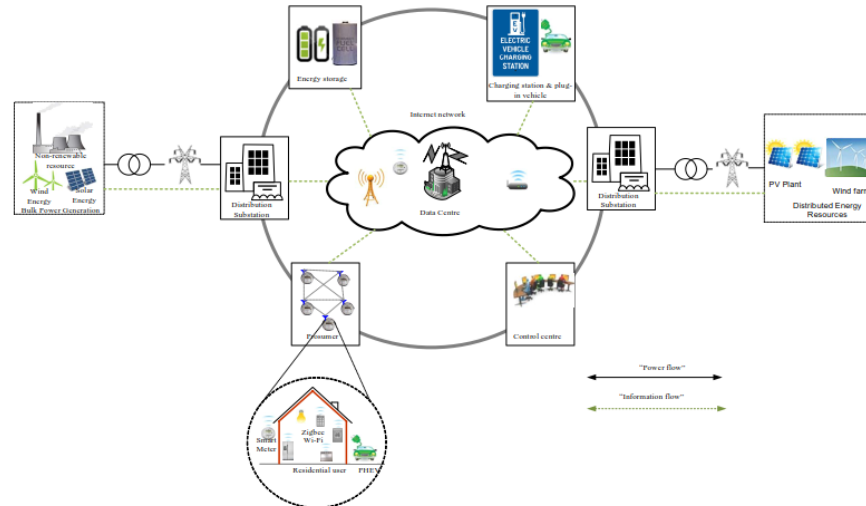

Figure 4.2: IoE Architecture

effect by capturing the solar radiation with the PV cell that are interconnected forming a PC panel, made of semiconductor material;

It is no doubt true that, one of the most important application of IoE is the "smart grid", i.e. a smart electricity distribution with an integrated system for monitoring and control, passing in this way from a centralized power generation to a more safe and efficient energy networks.

A general IoE architecture is shown in Figure 4.2. Energy networks as well as internet networks, must supply a reliable system for exchanging energy between different kind of sources and loads; it will be controlled and handled via Internet using a peer-to-peer exchange of information and energy. The key enabling technology of IoE, allowing the communication with all the sources and load, are the "energy router" that are placed in different points within the energy networks, as happens for the transformer in the today's grid. They take care of elaborate information, supply electricity and convert voltage so that different goals like efficiency and safety of the power system and optimization of energy usage balancing supply and demand, are reached.

4.2.1 State of the Art of Internet of Energy

In the literature, a lot of works have been done regarding the linking between the Internet of Things (IoT) world and the power electronics. Rajeev in [44], presents an innovative and economic method to handle the several assets of a microgrid such as resource allocations and power management by using a hierarchical structure based on cloud computing approach; the use of the cloud allow to collect the past and

present data, making the information more precise and optimizing services for users. Li in [45] proposes a wireless distribution network (WDN) for the construction of smart grid applications; the scope of his work is to utilize a smart distribution network to support the Internet of Power (IoP), i.e. not only controlling communication devices but also power electronic devices having an integrated transceivers. Kafle in his work [46] compares internet and energy networks such as their services, architecture and security in order to detect the key features and the principal challenges to be met in changing the electricity distribution system to a reliable and powerful platform for the exchange of electrical energy. Moscatelli in [47] introduces an original SoC solution to accomplish the different requirements requested by modern smart grids, also addressed by Rana in [50], and smart meters such as security, sensing accuracy and power consumption; nowadays smart grids are linking the whole power grid to Internet, dealing also with electric vehicle, renewable energy sources and street lighting systems, leading to a new revolution in the technology world, called "Internet of Energy" (IoE). Ramamurthy in [49] explains the development and the opportunities offered by the union of the power sector with the Internet of Things, pointing out as in the last period, different machine-learning applications have been developed leading to the "Internet of Energy" and how IoT has the strength to undoubtedly change the industrial sector. An example of the most important applications of such union are smart meters and smart thermostats, that use Internet to send electricity consumption data, net metering, temperature or humidity data inside a home to the cloud. In this way the user can modify the temperature with its smartphone simply setting the thermostat. Generally, the most common applications of the IoE deals with the condition checking and prognostic maintenance of several assets, that is checking the data sent to the cloud with the machine-learning algorithm in order to have an healthy system with a low percentage of failure and at the same time an increasing efficiency of production. The author also affirms that a significant evolution in the future will be the holistic optimization of the entire power network with the scope of decentralization and defossilization of the power sector, exploiting in this way only the renewable energy.

4.3 FURTHER DEVELOPMENTS

One of the possible improvements that could be adopted in the second set of trials is the use of a new FPGA, i.e. the commercial board with a Xilinx Zynq-7000 XC7Z010 having higher performance respect to the Xilinx Artix-7 100T (i.e. the operating system Linux can be implemented). This component is suitable to our prototyping purposes, having on board both FPGA resources (needed for the real time optical communication) and a real 600+MHz ARM A9 core with its embedded

peripherals, while the optical transceiver are absent and will be added on a custom board using an expansion connector.

Hence, we guess that with the adoption of a more powerful FPGA, the latency will be further decreased, nearing to the theoretical value calculated as $1.2 \mu s$. Besides, a short overhead time will allow to push the switching (and control sampling) frequency to the higher limits possible with SiC power MOSFETS (100kHz +), and also the 4 byte that at the moment are free, could be used to allow more feedback data signals to be added for PEC diagnostics and prognostics computed off board.

Other ways to optimize the performance of our system could be to improve the C control code that handle the control unit; the use of a different line code such as 128/130b; the use of the SFP (small form-factor pluggable) transceiver, that will allow an higher bit-rate in the order of 1 Gbps, and as result the decreasing of the latency. Also, the Forward Error Detection (FED) could be implemented, but since a handshaking mechanism must be implemented, the performance could decrease. Another improvement could be the use a new different line code, i.e. the use of the Aurora 64B/66B developed by Xilinx for low-cost and high data-rate application that utilize serial point-to-point connectivity. The reason for which we don't use this code is due to our boards that don't have an hardware structure for its implementation, in fact slots at high speed are needed. However, the use of the Aurora 64B/66B imply an increase in terms of costs since involves the use of new transceivers and new type of fibers made with different material and smaller core, i.e. Graded-Index Perfluorinated POF $120 \mu m$ core, that supports the Gigabit on short distances.

To sum up, further work will see the implementation of advanced control algorithms on a new higher performance platform, enabling smarted power conversion, and the telemetry section needed to upload working data on a cloud data pool, making remote monitoring and fault analysis feasible.

4.3.1 *A cloud approach for controlling Power Electronic Converters*

Power electronics will continue to be an enabling technology to address our future electricity needs. It is expected that new power devices for higher power, higher frequency, and lower losses will continue to be invented. Global energy concerns will provoke a large interest in the increase of the conversion efficiency and more application of PE in power quality, distributed generation, energy conservation and smart grids. So, the integration of power and control circuitry into functional modules will result in system having both reliability and affordability.

One the most important and revolutionary application is the link between the Power Electronic Converters and the Internet. In fact, despite the numerous benefits of the optical link, already described in

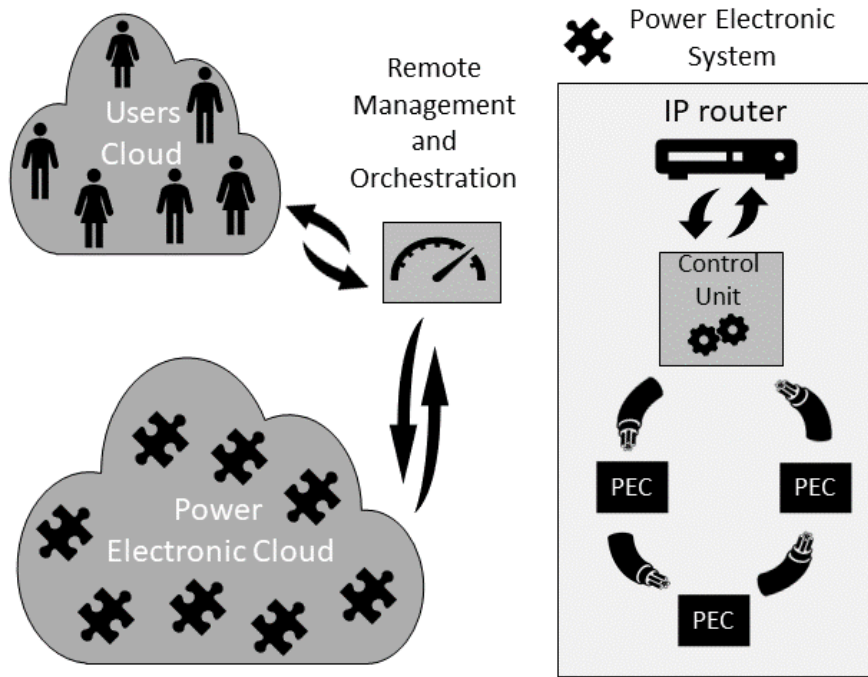

Figure 4.3: The daisy chain control scheme (on the right) as an element of the power electronic cloud

the Chapter 2, it also make easy the integration with cloud following the Internet of Things paradigm. As depicted in Figure 4.3, the Control Unit can be linked to an IP router to permit networking among several power electronic system within a Power Electronic Cloud distributed in the Internet. The daisy chain control bus, besides enabling a remotized control by the Control Unit, may transport telemetry data that can be sent through the Internet in upstream, or may transmit in downstream the commands coming from the Internet to each PEC.

So, the power electronic systems are virtually placed within a cloud relying on the Internet data transport to link systems one to each other. Depending on the specific application, the power electronic system could also benefit from the data from a cloud of users that may greatly help in optimizing the overall effectiveness of the power electronic cloud.

An application field for which this approach could be largely beneficial is the generation of electricity from renewable sources. In this case, the power electronic systems are electricity generators such as solar cells and wind turbines, and the users are families and companies delivering data on power consumption.

4.4 CONCLUSION

During the last years, real-time distributed controls had an important growth in factory automation and motion control systems. In order to provide a consistent control and data communication environment for the distributed controller different, several communication protocols have been proposed. However, while industrial communication protocols (point-to-point serial interface links and the multi-point connection offered by LAN) provide distributed control and communications on a field level (connecting drives, PLCs, controllers, sensors, actuators) this thesis proposes distributed control on a switching level, bring modular design, significant flexibility and hierarchical control.

As clarified in the previous Chapter, being the optical link close to the PEC it will be affected by the EMI, noise immunity became a key role in order to build a system having both reliability and robustness. Moreover, previous schemes of control used point-to-point serial interface links RS 232 or RS 422) to link the motor drives to the control unit. In this way one CU must handle different motor and also manage the communication between them, which could overload the control unit and limit the response time.

Hence, communication relying on optical fiber plays an important role in many industrial motor drive applications guaranteeing integrity and providing mission-critical system control and status communications. Clearly, one of the most important application of optical fiber is for those systems that work in noisy and unshielded environments in which signal integrity could be compromised.

Our project made use of a lot of components off-the-shelf in an innovative manner. In fact, the use of a plastic optical fiber bus in order to implement a remotized control of several power electronic converters has been proposed. In particular, we are able to control a small motor (few watts), having low cost and low danger, generally used in washing machines, small drills and ventilator.

The adopted solution follows the recommendation [40] for a multi-layer structure in controlling PECs. In particular, in according of this scheme, the converter control and the previous layers are assigned to a control unit while the switching and the hardware control layer forms the power unit, communicating through an optical bus made with a pair of plastic optical fiber. To link the PECs, a daisy-chain topology has been proposed allowing us to control up to 10 PECs, with a maximum distance between two nodes of 40 meters.

Regarding the protocol used to handle the communication on the optical bus, we started from the [31] adapting it to the available hardware. Each PEC use a packet made of 132 bits, with 16 bits for the /START and /STOP, 4 bits for the headers and 112 bits of payload for bidirectional communications, thus enabling control remotizing, telemetry and remote orchestration.

A proof-of-concept demonstrator has been implemented and described, showing the feasibility of such an optical control structure: the trials done in the laboratory showed the implementability of such a optical link with a latency (transmission time between two nodes) of $4 \mu s$, very near to the hypothetical latency of $1.2 \mu s$, proving the possibility of remotely controlling a motor with our photonic bus. Moreover, limiting factors to the computation time that the control unit can dedicate to the nodes, to the refresh frequency of the PECs and to the available bandwidth of the fiber were discussed.

Our demonstrator will allow the implementation of power clouds in power electronic systems that will take advantage of a software-defined remote management and orchestration in order to optimize the management of several power electronic systems. Moreover, telemetry data collected in the power electronic cloud will be exploited together with aggregated data from users for a holistic optimization.

Finally, with this work several goal have been reached both in the Photonics and in the Power Electronics World:

Contributions in Photonics

- Develop of a new application of photonics
- Increasing the transmission distance
- Data collection from the power unit
- Internet of Power: remote control of complex systems, with augmented knowledge of field converters status/health

Contributions in Power Electronics

- Simplification of the power converter
- Long distance control
- Multi-converter control
- Ease of data extraction from the field (modules temperature, junction temperature, electrical quantities, estimate of mechanical quantities)
- Advanced diagnostics and prognostics

Next steps of this activity within the Power Electronic Innovation Center (PEIC) of Politecnico di Torino will see the extension of the proposed scheme in order to control a higher number of PECs and more challenging power electronic devices, such as battery charger, electric motors in the order of kW or MW or an active front end, optimizing the hardware and software layers, with the goal of bringing up a first internet of power enabled distributed control device.

BIBLIOGRAPHY

- [1] N. Mohan, T. Undeland, W. Robbins, "Power electronics : converters, applications, and design" 3rd ed., p.802, John Wiley & Sons, 2003.
- [2] S. Chakraborty, M. Simoes, W. Kramer et al., "Power electronics for renewable and distributed energy systems: a sourcebook of topologies, control and integration", Springer, 2013.
- [3] P.T. Krein, "Elements of power electronics", 1st ed., p.794, Oxford University Press, 2014.
- [4] N. Mohan, "Power Electronics: A First Course", p.270, John Wiley & Sons, 2012.
- [5] G. Ellis, "Control System Design Guide", p.464, Elsevier Academic Press, 2004.
- [6] J. Zhao, Y. Yu, "Brushless DC Motor Fundamentals Application Note", 2011.
- [7] A. Hughes, "Electric Motors and Drives: Fundamentals, Types and Applications", 3rd ed., Elsevier Academic Press, 2006.
- [8] N. Sridhar, "Power electronics in motor drives: Where is it?", Texas Instruments, 2015.
- [9] G.S. Buja, W. Zoccarato, "Signal processor controller for a three-phase PWM inverter", *IFAC Proceedings Volumes*, 1983, vol. 16, pp. 461-467.
- [10] P.V. Pulgamkar, S.G. Deshpande, V.R. Dharme, "Application of Power Electronics to Power System", Technical Research Paper Competition for Students, 2017.
- [11] V. Vlatkovic, and D. Borojevic, "Digital-Signal-Processor-Based Control of Three-phase Space Vector Modulated Converters", *IEEE Transactions on Industrial Electronics*, Vol. 41, No. 3, pp. 326-332, June 1994.
- [12] I. Celanovic, I. Milosavljevic, D. Boroyevich et al. "A new distributed digital controller for the next generation of power electronics building blocks", vol. 2, pp. 889-894, Fifteenth Annual IEEE Applied Power Electronics Conference and Exposition, APEC 2000.

- [13] T. Ericson, Y.Khersonsky, P.Steimer, "PEBB Concept Applications in High Power Electronics Converters", IEEE 36th Conference on Power Electronics Specialists, 2005, pp. 2284–2289.
- [14] G. Francis, R. Burgos, F. Wang, D. Boroyevich, "A universal controller for distributed control of power electronics conversion systems", Computers in Power Electronics, 2006. COMPEL'06. IEEE Workshops on, 2006, pp. 8-14.
- [15] G. Francis, R. Burgos, I. Celanovic, F. Wang, D. Boroyevich, "A universal controller for distributed control of power electronics systems in electric ships", IEEE American Control Conference, 2005, pp. 1999–2004.
- [16] T. Ericson, A. Tucker, "Power Electronics Building Blocks and Potential Power Modulator Applications," IEEE Conference Record of the Twenty-Third International Power Modulator Symposium, New York, 1998, pp. 12-15.
- [17] T. Ericson, "Power Electronic Building Blocks-a systematic approach to power electronics", IEEE Power Engineering Society Summer Meeting 2000, Vol. 2, pp.1216 - 1218.
- [18] T. Laakkonen, "Distributed Control Architecture Of Power Electronics Building-Block-Based Frequency Converters", Lappeenranta, 2010.
- [19] J.A. Du Toit, A.D. Le Roux, J.H.R. Enslin, "An Integrated Controller Module for Distributed Control of Power Electronics", IEEE APEC'98 Proceedings, pp. 874-880, 1998.
- [20] P.L.G. Malapelle, G. Tom, R. Moruzzi, A. Oliva, "A New, Modular, Programmable, High Speed Digital Control for Large Drives", IEEE IECON 20th International Conference on Industrial Electronics, Control and Instrumentation 1994, vol. 1, pp. 210-14.
- [21] E. Bassi, F. Benzi, L. Lusetti, G.S. Buja, "Communication Protocols for Electrical Drivers", IEEE IECON Proceedings 1995, vol. 2, pp. 706-711.
- [22] A. Watson, H. Dang, P. Wheeler et al. "A novel multilevel converter structure integrated into power systems and its performance evaluation", in 13th European Conference on Power Electronics and Applications, pp. 1-10, 2009.
- [23] I. Milosavljevic, "Power Electronics System Communication," Blacksburg, Virginia, 1999.
- [24] I. Milosavljevic, D. Borojevic, "Modularized Control Architecture for Power Converters," VPEC Annual Seminar, 1998.

- [25] I. Milosavljevic, Z. Ye, D. Boroyevich, and C. Holton, "Analysis of converter operation with phase-leg control in daisy-chained or ring-type structure," IEEE 30th Annual IEEE Power Electronics Specialists Conference, pp. 1216 – 1221, 1999.
- [26] D. Vaidya, S. Mukherjee, M. A. Zagrodnik and P. Wang, "A review of communication protocols and topologies for power converters," IECON 2017 - 43rd Annual Conference of the IEEE Industrial Electronics Society, Beijing, 2017, pp. 2233-2238.
- [27] G. Francis, "A Synchronous Distributed Digital Control Architecture for High Power Converters," Blacksburg, Virginia, 2004.
- [28] G. Francis, R. Burgos, F. Wan, and D. Boroyevich, "A power electronics communication protocol for distributed digital control architectures," in IEEE Power and Energy Society General Meeting, Pittsburgh, 2008.
- [29] S. Abrate, A. Nespola, S. Straullu, D. Zeolla, P. Savio, and R. Gaudino, "POF-PLUS Handbook", Handbook of the European POF-PLUS Project 2008-2011, 06/2011.
- [30] O. Ziemann et al, "POF handbook: optical short range transmission systems", 2nd ed., Springer-Verlag GmbH, 2008
- [31] A. Nespola, S. Straullu, P. Savio, S. Abrate, D. Cardenas, J. C. Ramirez Molina, N. Campione, R. Gaudino, and D. Zeolla, "First demonstration of real-time LED-based Gigabit Ethernet transmission on 50m of A4a.2 SI-POF with significant system margin", ECOC 2010, Torino, Italy
- [32] P. Savio et al, "A Physical Coding Sublayer for Gigabit Ethernet over POF", 19th International Conference on Plastic Optical Fibers, Yokohama, Japan, 10/2010.
- [33] D. Cárdenas et al, "A media converter prototype for 10-Mb/s ethernet transmission over 425 m of large-core step-index polymer optical fiber", Journal of Lightwave Technology, 2006. 24(12): p. 4946.
- [34] ETSI recommendation "Plastic Optical Fibre System Specifications for 100 Mbit/s and 1 Gbit/s" (TS 105 175-1), V 1.1.1, 2015.
- [35] X. Zhang et al., "A 15 kV SiC MOSFET gate drive with power over fiber based isolated power supply and comprehensive protection functions," APEC 2016, pp. 1967–1973.
- [36] J. P. Bazzo et al., "Thermal characteristics analysis of an IGBT using a fiber Bragg grating," Opt. Lasers Eng., vol. 50, no. 2, pp. 99–103, 2012.

- [37] K. M. Sousa et al., "Optical fiber Bragg grating sensors applied on energy conversion systems," in 2013 SBMO/IEEE MTT-S International Microwave & Optoelectronics Conference (IMOC), 2013, pp. 1-5.
- [38] S. Brehaut and F. Costa, "Gate driving of high power IGBT by wireless transmission," in 2006 CES/IEEE 5th International Power Electronics and Motion Control Conference, 2006, vol. 1, pp. 1-5.
- [39] T. Ericson, Y. Khersonsky, P. Schugart and P. Steimer, "PEBB - Power Electronics Building Blocks, from Concept to Reality," 2006 3rd IET International Conference on Power Electronics, Machines and Drives - PEMD 2006, The Contarf Castle, Dublin, Ireland, 2006, pp. 12-16.
- [40] IEEE Guide for Control Architecture for High Power Electronics (IMW and Greater) Used in Electric Power Transmission and Distribution Systems IEEE Std 1676-2010, 2011, 1-47
- [41] W. Li, L. Grégoire, S. Souvanlasy and J. Bélanger, "An FPGA-based real-time simulator for HIL testing of modular multilevel converter controller," 2014 IEEE Energy Conversion Congress and Exposition (ECCE), Pittsburgh, PA, 2014, pp. 2088-2094.
- [42] NOUREEN, Subrina Sultana et al. Real-Time Digital Simulators: A Comprehensive Study on System Overview, Application, and Importance. International Journal of Research and Engineering, [S.l.], v. 4, n. 11, p. 266-277, dec. 2017. ISSN 2348-7860.
- [43] A. Varatharajan, P. Savio, E. Vizzaccaro, S. Abrate, G. Pellegrino, V. Curri, "Remotized Control of Power Electronic Devices Exploiting a Plastic Optical Fiber Photonic Bus," 2018 20th International Conference on Transparent Optical Networks (ICTON), Bucharest, 2018.
- [44] T. Rajeev, S. Ashok, "A cloud computing approach for power management of microgrids," IEEE PES International Conference on Innovative Smart Grid Technologies, India, 2011.
- [45] Bin Li et al. "A novel wireless distribution network application to support further internet of energy," 11th International Conference on Wireless Communications, Networking and Mobile Computing (WiCOM 2015)
- [46] Y. R. Kafle, K. Mahmud, S. Morsalin, G. E. Town, "Towards an internet of energy," 2016 IEEE International Conference on Power System Technology (POWERCON), pp: 1-6.
- [47] A. Moscatelli, "Innovative system on chip platform for Smart Grids and internet of energy applications," 2016 IEEE Symposium on VLSI Circuits (VLSI-Circuits), pp: 1-2.

- [48] M. Yang, "Application of Power Electronics in Power System," 7th International Conference on Education, Management, Computer and Medicine (EMCM 2016)
- [49] A. Ramamurthy, P. Jain, "The Internet of Things in the Power Sector: Opportunities in Asia and the Pacific," ADB South Asia Sustainable Development Working Paper Series (No. 48), 2017.
- [50] M. Rana, "Architecture of the Internet of Energy Network: An Application to Smart Grid Communications," *IEEE Access*, 2017, vol: 5, pp: 4704-4710.
- [51] C. Capasso, O. Veneri, I. Motori, D. Assante, "A novel platform for the experimental training on Internet of Energy," 2018 IEEE Global Engineering Education Conference (EDUCON), pp: 1746-1752.
- [52] H. D. Mohammadian, "Internet of Energy: A solution for improving the efficiency of reversible energy," 2018 IEEE Global Engineering Education Conference (EDUCON), pp: 1890-1895.