

# LOS ÓRDENES ARQUITECTÓNICOS:

A= Cubierta (A1 Frontón)  
 B= Entablamento (B1 Friso, B2 Arquitrabe)  
 C= Columnata (C1 Capitel, C2 Fuste con y sin acanaladuras,  
 D= Plataforma (D1 Estilóbato) C3 Éntasis, C4 Basa)

## Griegos

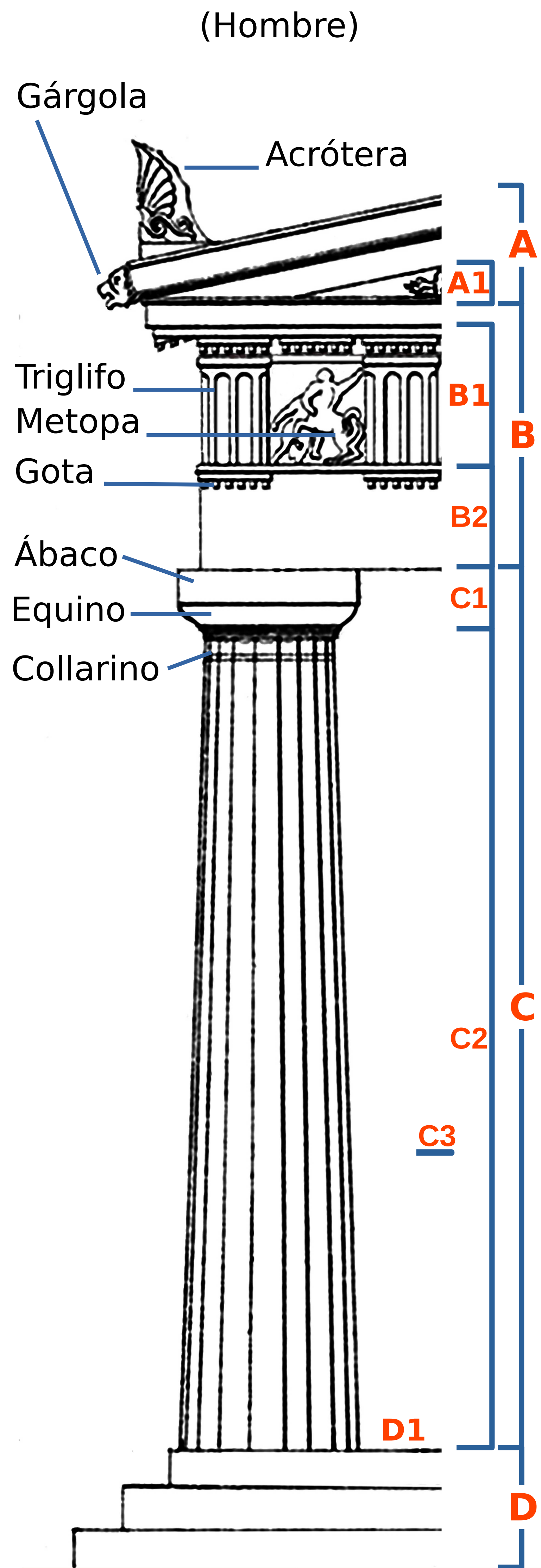

**ORDEN DÓRICO** Aristas vivas

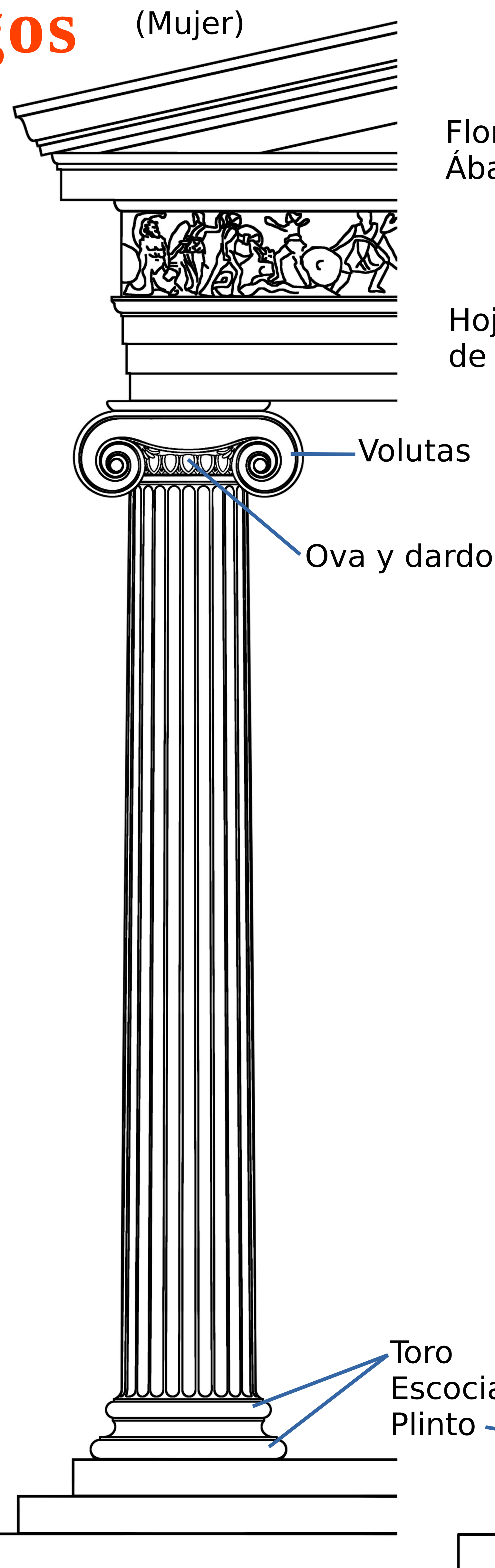

**ORDEN JÓNICO** Aristas matadas

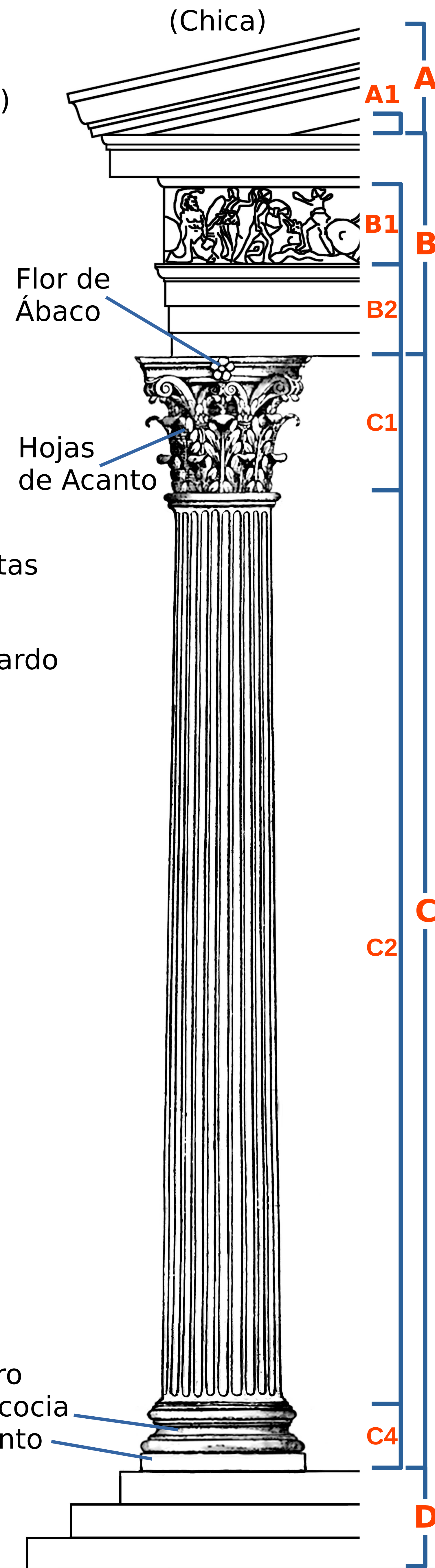

**ORDEN CORINTIO**

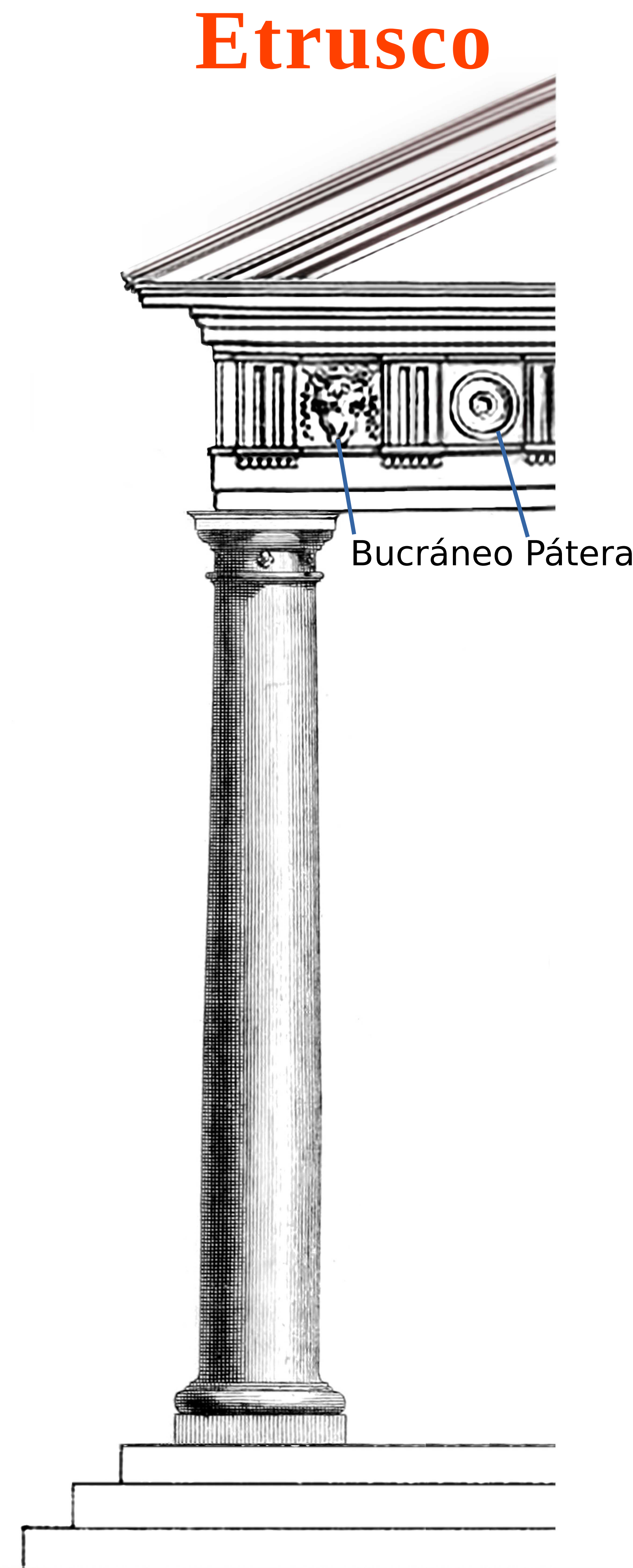

**ORDEN TOSCANO** Fuste liso

## Romano

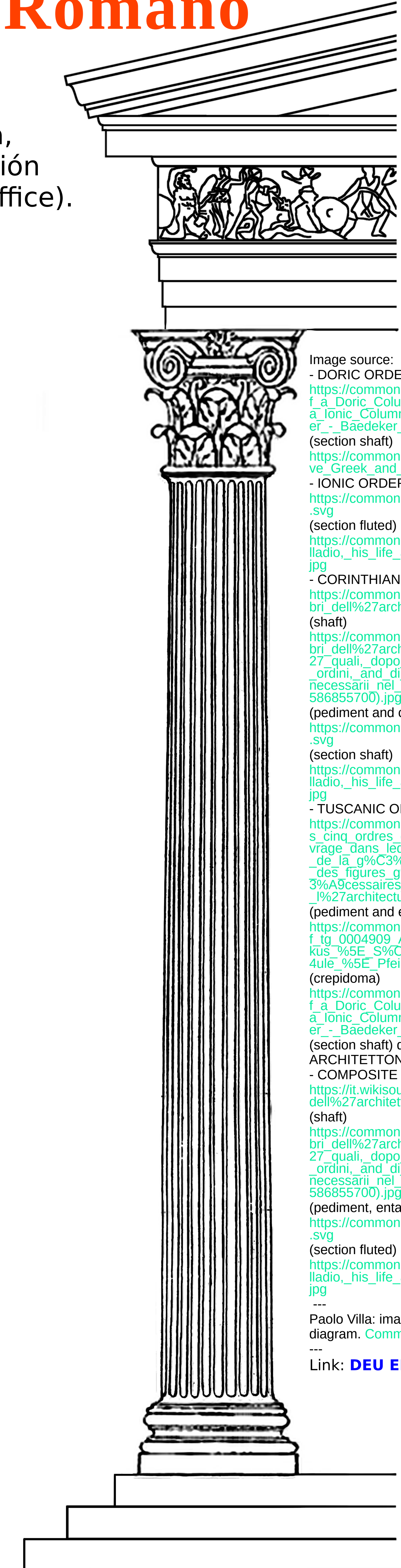

**ORDEN COMPUESTO O IMPERIAL**

Paolo Villa:  
 Composición de la tabla didáctica,  
 textos, signos gráficos, modificación  
 de imágenes (con: GIMP y LibreOffice).  
 Primera publicación:  
[Commons.Wikimedia.org](https://commons.wikimedia.org).

## Etrusco

Image source:  
 - DORIC ORDER:  
[https://commons.wikimedia.org/wiki/File:Diagram\\_of\\_a\\_Doric\\_Column\\_and\\_Entablature\\_Diagram\\_of\\_a\\_Ionic\\_Column\\_and\\_Entablature\\_Corinthian\\_Order\\_-\\_Baedeker\\_Karl\\_-\\_1894.jpg](https://commons.wikimedia.org/wiki/File:Diagram_of_a_Doric_Column_and_Entablature_Diagram_of_a_Ionic_Column_and_Entablature_Corinthian_Order_-_Baedeker_Karl_-_1894.jpg)  
 (section shaft)  
[https://commons.wikimedia.org/wiki/File:Comparative\\_Greek\\_and\\_Roman\\_Orders\\_160.jpg](https://commons.wikimedia.org/wiki/File:Comparative_Greek_and_Roman_Orders_160.jpg)  
 - IONIC ORDER:  
[https://commons.wikimedia.org/wiki/File:Ionic\\_order\\_\(section shaft\).svg](https://commons.wikimedia.org/wiki/File:Ionic_order_(section shaft).svg)  
 (section fluted)  
[https://commons.wikimedia.org/wiki/File:Andrea\\_Palladio\\_his\\_life\\_and\\_works\\_\(1902\)\\_14577922780.jpg](https://commons.wikimedia.org/wiki/File:Andrea_Palladio_his_life_and_works_(1902)_14577922780.jpg)  
 - CORINTHIAN ORDER:  
[https://commons.wikimedia.org/wiki/File:1\\_quattro\\_libri\\_dell'architettura\\_\(1790\)\\_pag015.png](https://commons.wikimedia.org/wiki/File:1_quattro_libri_dell'architettura_(1790)_pag015.png)  
 (shaft)  
[https://commons.wikimedia.org/wiki/File:1\\_quattro\\_libri\\_dell'architettura\\_di\\_Andrea\\_Palladio\\_-\\_ne%27\\_quali\\_dopo\\_un\\_breve\\_trattato\\_de%27\\_cinque\\_ordini\\_and\\_di\\_quelli\\_auertimenti\\_che\\_sono\\_pi%27\\_necessari\\_nel\\_fabricare\\_si\\_tratta\\_delle\\_case\\_\(1458685700\).jpg](https://commons.wikimedia.org/wiki/File:1_quattro_libri_dell'architettura_di_Andrea_Palladio_-_ne%27_quali_dopo_un_breve_trattato_de%27_cinque_ordini_and_di_quelli_auertimenti_che_sono_pi%27_necessari_nel_fabricare_si_tratta_delle_case_(1458685700).jpg)  
 (pediment and crepidoma)  
[https://commons.wikimedia.org/wiki/File:Ionic\\_order\\_\(section shaft\).svg](https://commons.wikimedia.org/wiki/File:Ionic_order_(section shaft).svg)  
 (section shaft)  
[https://commons.wikimedia.org/wiki/File:Andrea\\_Palladio\\_his\\_life\\_and\\_works\\_\(1902\)\\_14577922780.jpg](https://commons.wikimedia.org/wiki/File:Andrea_Palladio_his_life_and_works_(1902)_14577922780.jpg)  
 - TUSCANIC ORDER:  
[https://commons.wikimedia.org/wiki/File:Regles\\_de\\_s\\_cinq\\_ordres\\_d%27architecture\\_de\\_Vignole\\_-\\_ou\\_vrage\\_dans\\_lequel\\_on\\_donne\\_une\\_id%C3%A9e\\_de\\_la\\_g%C3%A9ometrie\\_les\\_3%C3%A9l%C3%A9ments\\_n%C3%A9cessaires\\_%C3%A0\\_%27%C3%A9tude\\_de%27architecture\\_la\\_\(14581151249\).jpg](https://commons.wikimedia.org/wiki/File:Regles_de_s_cinq_ordres_d%27architecture_de_Vignole_-_ou_vrage_dans_lequel_on_donne_une_id%C3%A9e_de_la_g%C3%A9ometrie_les_3%C3%A9l%C3%A9ments_n%C3%A9cessaires_%C3%A0_%27%C3%A9tude_de%27architecture_la_(14581151249).jpg)  
 (pediment and entablature)  
[https://commons.wikimedia.org/wiki/File:Fotothek\\_d\\_f\\_tg\\_0004909\\_Architektur\\_%E\\_Portal\\_%E\\_Portikus\\_%E\\_S%C3%A4ulenordnung\\_%E\\_S%C3%A4ule\\_%E\\_Pfeiler\\_%E\\_Kapitell\\_%E\\_B.jpg](https://commons.wikimedia.org/wiki/File:Fotothek_d_f_tg_0004909_Architektur_%E_Portal_%E_Portikus_%E_S%C3%A4ulenordnung_%E_S%C3%A4ule_%E_Pfeiler_%E_Kapitell_%E_B.jpg)  
 (crepidoma)  
[https://commons.wikimedia.org/wiki/File:Diagram\\_of\\_a\\_Ionic\\_Column\\_and\\_Entablature\\_Corinthian\\_Order\\_-\\_Baedeker\\_Karl\\_-\\_1894.jpg](https://commons.wikimedia.org/wiki/File:Diagram_of_a_Ionic_Column_and_Entablature_Corinthian_Order_-_Baedeker_Karl_-_1894.jpg)  
 (section shaft) draw by Paolo Villa: GLI ORDINI ARCHITETTONICI: greci etrusco romano  
 - COMPOSITE ORDER:  
[https://it.wikisource.org/wiki/Pagina:1\\_quattro\\_libri\\_dell'architettura.djvu/65](https://it.wikisource.org/wiki/Pagina:1_quattro_libri_dell'architettura.djvu/65)  
 (shaft)  
[https://commons.wikimedia.org/wiki/File:1\\_quattro\\_libri\\_dell'architettura\\_di\\_Andrea\\_Palladio\\_-\\_ne%27\\_quali\\_dopo\\_un\\_breve\\_trattato\\_de%27\\_cinque\\_ordini\\_and\\_di\\_quelli\\_auertimenti\\_che\\_sono\\_pi%27\\_necessari\\_nel\\_fabricare\\_si\\_tratta\\_delle\\_case\\_\(1458685700\).jpg](https://commons.wikimedia.org/wiki/File:1_quattro_libri_dell'architettura_di_Andrea_Palladio_-_ne%27_quali_dopo_un_breve_trattato_de%27_cinque_ordini_and_di_quelli_auertimenti_che_sono_pi%27_necessari_nel_fabricare_si_tratta_delle_case_(1458685700).jpg)  
 (pediment, entablature and crepidoma)  
[https://commons.wikimedia.org/wiki/File:Ionic\\_order\\_\(section fluted\).svg](https://commons.wikimedia.org/wiki/File:Ionic_order_(section fluted).svg)  
 (section fluted)  
[https://commons.wikimedia.org/wiki/File:Andrea\\_Palladio\\_his\\_life\\_and\\_works\\_\(1902\)\\_14577922780.jpg](https://commons.wikimedia.org/wiki/File:Andrea_Palladio_his_life_and_works_(1902)_14577922780.jpg)  
 ---  
 Paolo Villa: image correction, composition, text diagram. Commons kimedia.org: first publication  
 ---  
 Link: [DEU](#) [ENG](#) [ESP](#) [ITA](#) ... [otro lingue](#)