



**HAL**  
open science

## Periodic-Finite-Type Shift Spaces

Marie-Pierre Béal, Maxime Crochemore, Bruce Moision, Paul Siegel

► **To cite this version:**

Marie-Pierre Béal, Maxime Crochemore, Bruce Moision, Paul Siegel. Periodic-Finite-Type Shift Spaces. IEEE Transactions on Information Theory, 2011, 57 (6), pp.3677-3691. hal-00619782

**HAL Id: hal-00619782**

**<https://hal.science/hal-00619782v1>**

Submitted on 13 Feb 2013

**HAL** is a multi-disciplinary open access archive for the deposit and dissemination of scientific research documents, whether they are published or not. The documents may come from teaching and research institutions in France or abroad, or from public or private research centers.

L'archive ouverte pluridisciplinaire **HAL**, est destinée au dépôt et à la diffusion de documents scientifiques de niveau recherche, publiés ou non, émanant des établissements d'enseignement et de recherche français ou étrangers, des laboratoires publics ou privés.

# Periodic Finite-Type Shift Spaces

Marie-Pierre Béal, *Member, IEEE*, Maxime Crochemore, *Member, IEEE*,  
Bruce E. Moision, *Member, IEEE*, and Paul H. Siegel, *Fellow, IEEE*

**Abstract**— We study the class of periodic finite-type (PFT) shift spaces, which can be used to model time-varying constrained codes used in digital magnetic recording systems. A PFT shift is determined by a finite list of periodically forbidden words. We show that the class of PFT shifts properly contains all finite-type (FT) shifts, and the class of almost finite-type (AFT) shifts properly contains all PFT shifts. We establish several basic properties of PFT shift spaces of a given period  $T$ , and provide a characterization of such a shift in terms of properties of its Shannon cover (i.e., its unique minimal, deterministic, irreducible graph presentation). We present an algorithm that, given the Shannon cover  $\mathcal{G}$  of an irreducible sofic shift  $X$ , decides whether or not  $X$  is PFT in time that is quadratic in the number of states of  $\mathcal{G}$ . From any periodic irreducible presentation of a given period, we define a periodic forbidden list, unique up to conjugacy for that period, that satisfies certain minimality properties. We show that an irreducible sofic shift is PFT if and only if the list corresponding to its Shannon cover  $\mathcal{G}$  and its period is finite. Finally, we discuss methods for computing the capacity of a PFT shift from a periodic forbidden list, either by construction of a corresponding graph or in a combinatorial manner directly from the list itself.

**Index Terms**—Shift spaces, sofic system, constrained code, finite-type, capacity of constrained system, periodic constraint.

## I. INTRODUCTION

**D**IGITAL data storage systems based upon magnetic and optical recording typically use constrained modulation codes designed to efficiently avoid sequences that are problematic to data recording and retrieval [1].

The family of  $(d, k)$ -constrained run-length limited (RLL) codes over the binary alphabet  $\{0, 1\}$  is a well known example. The code sequences satisfy the constraint that the number of 0s between consecutive 1s in a sequence is at least  $d$  and no more than  $k$ . Their purpose is to aid in timing recovery and to limit intersymbol interference. The  $(d, k)$ -RLL constraint is characterized by a finite list of forbidden words. For example, the  $(1, 3)$ -RLL sequences are precisely those in which neither of the words  $\{11, 0000\}$  appears. Such constraints are called *finite-type (FT)*.

Another widely used family of codes are the  $c$ -charge constrained codes over the bipolar alphabet  $\{\pm 1\}$ . Here, the code

M.-P. Béal and M. Crochemore are with Institut Gaspard-Monge, Université Paris-Est, 77454 Marne-la-Vallée Cedex 2, France (e-mail: {beal, mac}@univ-mlv.fr).

B. E. Moision was with the Mathematical Sciences Research Center, Lucent Technologies, Murray Hill, NJ. He is now with the Communications Systems and Research Section, Jet Propulsion Laboratory, 4800 Oak Grove Drive, Pasadena, CA 91101-8099 (e-mail: bmoision@shannon.jpl.nasa.gov).

P. H. Siegel is with the Center for Magnetic Recording Research, University of California, San Diego, La Jolla, CA 92093-0401, USA (e-mail: psiegel@ucsd.edu).

This work was supported in part by the UC Micro Program under grant 98-140 in cooperation with Marvell Semiconductor, Incorporated, by NSF grants CCR-9612802 and CCF-0514859, by Université Paris-Est, and by the Center for Magnetic Recording Research. The material in this paper was presented in part at the IEEE International Symposium on Information Theory, Washington, DC, June 2001.

sequences limit the running-digital-sums of subsequences to a range of  $c > 2$  consecutive integer values. These codes, often called *dc-free*, ensure that the average power spectral density of code sequences vanishes at zero frequency. In contrast to the  $(d, k)$ -RLL constraint, the  $c$ -charge constraint cannot be characterized by a finite list of forbidden words. However, these constraints can be specified by a countably infinite set of forbidden words. They are representative of constraints called *almost finite-type (AFT)*.

During the past decade, advances in digital recording have led to the introduction of constrained codes that are described by time-varying constraints. An important example is the family of Time-varying Maximum Transition Run codes with parameters  $(j, j + 1)$ , denoted TMTR( $j, j + 1$ ). These codes constrain the run-lengths of 1s to be at most  $j$  starting at odd time indices and  $j + 1$  beginning at even time indices [2], [3], [4], [5]. These codes were developed for systems employing higher-order partial-response equalization and maximum-likelihood sequence detection. For selected partial-response target channels, they are *distance-enhancing* codes; that is, they eliminate bit patterns occurring in the dominant error events of the target-matched sequence detector [6], [7], [8]. Recently, generalized TMTR codes, which limit maximum run-lengths of 1s beginning at more than two phases, have also been studied [9].

Time-varying constraints also arise in the context of constrained codes with unconstrained positions, introduced in [10] and further studied in [11], [12], [13]. These codes permit the insertion of parity bits generated by a systematic error-correcting code into specified bit locations in a constrained code sequence, thereby efficiently combining the modulation and error correction functions of the two codes.

In general, these time-varying constraints are not FT, but they all have the property that they can be specified by a finite list of periodically forbidden words. The study of such time-varying constrained systems was initiated in [14], [15], where they were called *periodic finite-type (PFT)*. The purpose of this paper is to present a detailed analysis of their properties.

Section II reviews necessary concepts, terminology, and notation for use in the rest of the paper.

In Section III, we formulate the definition of PFT constraints in terms of shift spaces, and address their characteristics within the framework of symbolic dynamics. We study basic properties of PFT shifts that are characterized by a finite periodic list of forbidden words for a given period  $T$ . We refer to such shifts as PFT( $T$ ) shifts, and we say that a shift is PFT if, for some period  $T > 0$ , it is PFT( $T$ ). We show that PFT shifts are sofic, and we demonstrate that the family of PFT shifts properly contains the family of FT shifts and is properly contained within the family of AFT shifts [16]. We also explore the periods  $T$  for which a PFT shift can be PFT( $T$ ).

Section IV gives several characterizations of an irreducible PFT shift in terms of its graph presentations. In particular,

we give a necessary and sufficient condition for an irreducible sofic shift to be a PFT( $T$ ) shift, based upon properties of its Shannon cover (i.e., its unique minimal, deterministic, irreducible graph presentation) [17]. This leads to an algorithm that, when presented with the Shannon cover  $\mathcal{G}$  of an irreducible sofic shift, decides in time quadratic in the number of states of  $\mathcal{G}$  if the shift is PFT.

In Section V, we study periodic forbidden lists that offer a concise description of a PFT shift. From an irreducible presentation with period  $T$ , we derive a periodic forbidden list that satisfies a minimality property for the chosen period  $T$ . We prove that the list, up to a permutation of the time indices, is unique and independent of the choice of the presentation with period  $T$ . The notion of minimality, as well as the definition of the list, are directly inspired by the construction of the set of first offenders of a FT shift [18], [16], so we refer to the periodic forbidden list as the set of *periodic first offenders* for the period. We then consider the periodic first offenders corresponding to the Shannon cover and the period of its underlying graph. We prove that an irreducible sofic shift is PFT if and only if this list is finite.

We define the size of a periodic forbidden list to be the sum of the lengths of its words. We prove that the minimum size over all periodic forbidden lists for all periods is attained by a periodic forbidden list for a period dividing the period of the graph underlying the Shannon cover.

Finally, in Section VI we discuss methods for computing the capacity of a PFT shift from a periodic forbidden list description of the shift. The conventional method for computing the capacity of a sofic shift is based upon determining the largest real eigenvalue of the adjacency matrix of a lossless presentation of the system. We review a number of techniques, several of which are formulated in terms of the theory of finite automata, for constructing such a presentation from a finite list of periodically forbidden words.

We then present a quite different method which relies upon the *Principle of Inclusion and Exclusion* [19], [20] from enumerative combinatorics. It extends to PFT shifts the technique presented by Pimentel and Uchôa-Filho in [21] for computing the capacity of FT shifts from a finite list of forbidden words. It appears to be quite effective when the size of the periodic forbidden blocks is large compared to the number of blocks in the list, as is the case for some TMTR constraints.

Section VII concludes the paper.

## II. BACKGROUND AND TERMINOLOGY

In this section we review terminology and background results to be used in the remainder of the paper. The notation in Sections II-A and II-B follows that found in the text by Lind and Marcus [16], and a thorough presentation may be found there. Section II-C contains terminology on finite automata relevant to the construction procedures in Section VI-A. A more detailed exposition on automata may be found in [22].

### A. Shift Spaces

Let  $\Sigma^{\mathbb{Z}}$  denote the set of bi-infinite sequences

$$x = \dots x_{-3}x_{-2}x_{-1}x_0x_1x_2\dots$$

whose symbols are drawn from a finite alphabet  $\Sigma$ ,

$$\Sigma^{\mathbb{Z}} \stackrel{\text{def}}{=} \{x \mid x_i \in \Sigma, \forall i \in \mathbb{Z}\}.$$

A *word* or *block*  $w \in \Sigma^n$ , for some integer  $n$ , is a finite string of consecutive symbols. We say that  $w$  is a *subword*, *subblock*, or *factor* of the sequence  $x$ , or equivalently that  $x$  *contains*  $w$ , if  $w = x_i x_{i+1} \dots x_{i+n-1}$  for some index  $i$ . We denote this fact by  $w \prec_i x$ . To conveniently specify the position of a word within a sequence, we write

$$x_{[i,j]} \stackrel{\text{def}}{=} x_i x_{i+1} \dots x_j,$$

where  $i \leq j$ . We sometimes write  $x_{[i]}$  to denote  $x_i$ . When the context is clear, we will use similar concepts and notation when  $x$  denotes a word.

Let  $\Sigma^*$  be the collection of words over  $\Sigma$ , including the empty word, and let  $\Sigma^+$  denote the subset of non-empty words in  $\Sigma^*$ . The *length* of a word,  $|w|$ , is the number of symbols in  $w$ , and we refer to a block of length  $n$  as an *n-block*. The *shift map*  $\sigma$  takes a sequence  $x$  to the sequence  $y = \sigma(x)$  with  $i$ th coordinate  $y_i = x_{i+1}$ . The inverse of the shift map takes a sequence  $y$  to  $x = \sigma^{-1}(y)$  with  $i$ th coordinate  $x_i = y_{i-1}$ .

When speaking of a finite collection of words  $\mathcal{F}$ , we say that  $\mathcal{F}$  is *anti-factorial* or *non-redundant* if no word  $u \in \mathcal{F}$  is a factor of any word  $w \in \mathcal{F}$  with  $u \neq w$ .

Let  $\mathcal{F}$  be a collection of words over  $\Sigma$  and  $X_{\mathcal{F}}^{\Sigma}$  denote the subset of  $\Sigma^{\mathbb{Z}}$  consisting of all bi-infinite sequences that do not contain a word from  $\mathcal{F}$ . In this context  $\mathcal{F}$  is referred to as a *forbidden list*. A *shift space* is a set  $X = X_{\mathcal{F}}^{\Sigma}$ . This terminology reflects the fact that  $X$  is invariant under the operation of the shift map, i.e.,  $\sigma(X) = X$ . A shift space is a *shift of finite type* if there exists a finite set  $\mathcal{F}$  such that  $X = X_{\mathcal{F}}^{\Sigma}$ .

Let  $\mathcal{B}_n(X)$  denote the set of all length- $n$  words that occur in  $X$ . The *language* of  $X$  is the collection

$$\mathcal{B}(X) \stackrel{\text{def}}{=} \bigcup_{n=0}^{\infty} \mathcal{B}_n(X),$$

where  $\mathcal{B}_0(X) = \{\epsilon\}$ , the empty word. The language of a shift space determines the space [16, Proposition 1.3.4]. That is, a bi-infinite sequence  $x$  belongs to the shift space  $X$  if and only if all of its sub-blocks belong to  $\mathcal{B}(X)$ . Considering  $\mathcal{B}_N(X)$  as an alphabet, the *Nth higher power code*  $\gamma_N : X \rightarrow (\mathcal{B}_N(X))^{\mathbb{Z}}$  is the mapping

$$(\gamma_N(x))_{[i]} = x_{[iN, iN+N-1]},$$

which takes a sequence from  $X$  and breaks it into a sequence of non-overlapping  $N$ -blocks. The image of  $X$  under  $\gamma_N$ ,  $X^N \stackrel{\text{def}}{=} \gamma_N(X)$ , is the *Nth higher power shift* of  $X$ .

Let  $X$  be a shift space over  $\Sigma$ , and let  $\Psi : \mathcal{B}_{m+a+1}(X) \rightarrow \Gamma$  be a mapping from allowed  $(m+a+1)$ -blocks in  $X$  to symbols in an alphabet  $\Gamma$ . The *sliding block code* with *memory*  $m$  and *anticipation*  $a$  induced by  $\Psi$  is the mapping  $\psi : X \rightarrow \Gamma^{\mathbb{Z}}$  defined by

$$y = \psi(x),$$

where, for  $x \in X$ ,

$$y_i = \Psi(x_{[i-m, i+a]}).$$

A sliding block code  $\psi : X \rightarrow Y$  is a *conjugacy* from  $X$  to  $Y$  if it is invertible. The shifts  $X$  and  $Y$  are *conjugate* if  $Y = \psi(X)$  and  $\psi$  is a conjugacy.

## B. Sofic Shifts

A *labeled graph*  $\mathcal{G} = (G, \mathcal{L})$  consists of a graph  $G = (\mathcal{V}, E)$  with a finite set of states  $\mathcal{V} = \mathcal{V}(G)$ , a finite set of directed edges  $E = E(G)$  connecting the states, and a *labeling*  $\mathcal{L} : E \rightarrow \Sigma$  that assigns a label to each edge. Each edge  $e$  is directed, with initial state,  $i(e)$  and terminal state  $t(e)$ . A *path* in the graph is a finite sequence of edges  $\pi = e_1 e_2 \cdots e_N$  such that  $t(e_j) = i(e_{j+1})$ . The initial state of a path  $\pi = e_1 e_2 \cdots e_N$  is defined as  $i(\pi) = i(e_1)$ , and the terminal state is defined as  $t(\pi) = t(e_N)$ . A path is a *cycle* if  $i(\pi) = t(\pi)$ . The label of  $\pi$  is the word  $\mathcal{L}(\pi) = \mathcal{L}(e_1)\mathcal{L}(e_2)\cdots\mathcal{L}(e_N)$ .

Whereas a path is finite, a *walk* on  $G$  is a bi-infinite sequence of edges  $\xi = \cdots e_{-1} e_0 e_1 \cdots$  such that  $t(e_j) = i(e_{j+1})$ . The label of a walk is the sequence

$$\mathcal{L}_\infty(\xi) \stackrel{\text{def}}{=} \cdots \mathcal{L}(e_{-1})\mathcal{L}(e_0)\mathcal{L}(e_1)\cdots$$

A graph  $G$  is *irreducible* if for any pair of states  $I, J \in \mathcal{V}$  there exists a path with  $i(\pi) = I$  and  $t(\pi) = J$ . An *irreducible component* of a graph  $G$  is a maximal (with respect to inclusion of vertices) irreducible subgraph of  $G$ .

A vertex  $I \in \mathcal{V}$  is *stranded* if either no edges start at  $I$  or no edges terminate at  $I$ . A graph is *essential* if no vertex is stranded.

A graph has *local anticipation*  $a$  if  $a$  is the smallest non-negative integer such that, for each  $I \in \mathcal{V}$ , all paths of length  $a + 1$  that start at  $i$  and have the same label start with the same edge. Similarly, a graph has *local memory*  $m$  if  $m$  is the smallest nonnegative integer such that, for each  $I \in \mathcal{V}$ , all paths of length  $m + 1$  that end at  $i$  and have the same label end with the same edge. A graph is *deterministic* if it has local anticipation 0, i.e., if edges with the same initial state have distinct labels.

A graph is  $(m, a)$ -*definite* if, given any word  $w = w_{[-m, a]}$ , the set of paths  $\pi = e_{-m} \cdots e_0 \cdots e_a$  that generate  $w$  all agree in the edge  $e_0$ . If a graph is  $(m, a)$ -definite for some integers  $m$  and  $a$ , it is said to be *definite*. An irreducible graph is definite if and only if no two distinct cycles generate the same word. An  $(m, 0)$ -definite graph is said to be *finite-memory*.

A *sofic shift*  $X_{\mathcal{G}}$  is the set of bi-infinite sequences obtained by reading the labels of walks on  $\mathcal{G}$ ,

$$X_{\mathcal{G}} \stackrel{\text{def}}{=} \{x \mid \mathcal{L}_\infty(\xi) = x \text{ for some } \xi \text{ a walk on } \mathcal{G}\}.$$

We say that  $\mathcal{G}$  is a *presentation* or *cover* of  $X_{\mathcal{G}}$ , or  $\mathcal{G}$  *presents*  $X_{\mathcal{G}}$ . A sofic shift is *irreducible* if it has an irreducible presentation. The set of finite words generated by paths in  $\mathcal{G}$ , denoted  $\mathcal{S}(\mathcal{G})$ , is called a *constrained system*, and similar terminology is used in that context.

Let  $\mathcal{G}$  be a deterministic graph. For any word  $u \in \mathcal{B}(X_{\mathcal{G}})$ , we denote by  $\tau(u)$  the set of terminal states of all paths with label  $u$ . The cardinality of  $\tau(u)$  is called the *rank* of  $u$ , which we refer to as  $r(u)$ . If  $r(u) = 1$ , then  $u$  is called a *synchronizing word*, and it is said to *focus* to the single state in  $\tau(u)$ .

An irreducible sofic shift is *almost-finite-type (AFT)* if it has a presentation with finite local anticipation and finite local memory. Since every sofic shift has a deterministic presentation [16, Theorem 3.3.2], a sofic shift is AFT if and only if it has an irreducible, deterministic presentation with finite local memory.

Sofic shifts are shift spaces [16, Theorem 3.1.4]. Hence, for every  $X_{\mathcal{G}}$  there exists a forbidden list,  $\mathcal{F}$ , of words over  $\Sigma$  such that  $X_{\mathcal{G}} = X_{\mathcal{F}}^\Sigma$ .

There is a unique, up to labeled graph isomorphism, deterministic graph presenting an irreducible sofic shift with the minimal number of states [16, Theorem 3.3.18]. This graph is referred to as the *Shannon cover* of the shift. It is also called the *Fischer cover*. One can obtain the Shannon cover from any presentation via determinizing and state-minimizing algorithms, e.g., [16, pp. 92], [22, pp. 68]. A Shannon cover always has at least one synchronizing word [17]. An irreducible sofic shift is FT (resp. AFT) if and only if the Shannon cover is definite (resp. has finite local memory) [17].

The *follower set*  $F_{\mathcal{G}}(I)$  of state  $I$  in  $\mathcal{V}$  is the collection of labels of paths starting at  $I$ ,

$$F_{\mathcal{G}}(I) \stackrel{\text{def}}{=} \{\mathcal{L}(\pi) \mid \mathcal{L}(\pi) \in \mathcal{B}(X_{\mathcal{G}}) \text{ and } i(\pi) = I\}.$$

Note that for a graph,  $\mathcal{G}$ ,

$$\bigcup_{I \in \mathcal{V}(\mathcal{G})} F_{\mathcal{G}}(I) = \mathcal{B}(X_{\mathcal{G}}).$$

The follower set of a collection of states is simply the union of their respective follower sets. The  $N$ th *higher power graph*  $\mathcal{G}^N = (G^N, \mathcal{L}^N)$  of  $\mathcal{G}$  is the labeled graph with underlying graph  $G^N$  and the naturally induced labeling  $\mathcal{L}^N$ . Specifically, the vertex set is  $\mathcal{V}(G^N) = \mathcal{V}(G)$ , and there is one edge  $e_\pi$  in  $E(G^N)$  from  $I$  to  $J$  with label  $\mathcal{L}^N(e_\pi) = \mathcal{L}(\pi)$  for each path  $\pi$  of length  $N$  from  $I$  to  $J$  in  $G$ . The  $N$ th higher power graph presents the  $N$ th higher power shift,  $X_{\mathcal{G}^N} = (X_{\mathcal{G}})^N$ .

For  $I, J \in \mathcal{V}$ , let  $A_{IJ}$  denote the number of edges from  $I$  to  $J$  in  $G$ . The *adjacency matrix* of  $G$  is the  $|\mathcal{V}| \times |\mathcal{V}|$  matrix  $A_G = [A_{IJ}]$ .

Given a nonnegative matrix  $A$ , the *period of state*  $I$ ,  $\text{per}(I)$ , is the greatest common divisor of those integers  $n \geq 1$  for which  $(A^n)_{II} > 0$ , if such integers exist. Otherwise, we define  $\text{per}(I) = \infty$ . The *period*  $\text{per}(A)$  of  $A$  is defined as the greatest common divisor of the finite periods  $\text{per}(I)$ , or as  $\infty$  if none of the state periods  $\text{per}(I)$  is finite. The *period of a graph*,  $\text{per}(G)$ , is the period of its adjacency matrix. It is the same as the greatest common divisor of the lengths of cycles in  $G$ . The periods of the states in an irreducible graph are equal. For a labeled graph  $\mathcal{G} = (G, \mathcal{L})$ , the period of  $\mathcal{G}$  is defined as  $\text{per}(G)$ .

Let  $\mathcal{G}$  be a labeled graph. If  $p$  is a positive integer, a *coloring* of  $\mathcal{G}$  in  $p$  colors, or a *p-coloring* for short, is a function  $c$  from  $\mathcal{V}(\mathcal{G})$  to  $\{0, 1, \dots, p-1\}$  such that, whenever there is an edge from a state  $I$  to a state  $J$ ,  $c(J) = c(I) + 1 \pmod{p}$ . Note that an irreducible presentation has a coloring in  $p$  colors if and only if its period is a multiple of  $p$ .

We say that a graph  $G$  is *T-partite* if the vertices of  $G$  may be divided into  $T$  disjoint subsets  $D_0, D_1, \dots, D_{T-1}$  such

that any edge that begins in  $D_i$  terminates in  $D_{(i+1) \bmod T}$ . If  $\text{per}(G) = T$  then  $G$  is  $T$ -partite, and the sets  $D_0, D_1, \dots, D_{T-1}$  are referred to as the *period classes* of the graph.

The  $T$ -cascade of a graph  $G$  is the  $T$ -partite graph with vertex set given by  $T$  copies  $\mathcal{V}_0, \mathcal{V}_1, \dots, \mathcal{V}_{T-1}$  of the vertex set  $\mathcal{V}(G)$  and exactly one edge  $e$  from  $I \in \mathcal{V}_i$  to  $J \in \mathcal{V}_{(i+1) \bmod T}$  for each edge  $e$  from  $I$  to  $J$  in  $G$ . For a sofic shift  $\mathcal{G} = (G, \mathcal{L})$ , the  $T$ -cascade of  $\mathcal{G}$  is the shift presented by the  $T$ -cascade of  $G$  with the natural labeling induced by  $\mathcal{L}$ .

If  $\mathcal{G} = (G, \mathcal{L})$  is irreducible with  $\text{per}(G) = p$ , then  $\mathcal{G}^T = (G^T, \mathcal{L}^T)$  decomposes into  $q = \text{gcd}(p, T)$  irreducible components. Moreover, it is easy to verify that each component has period  $p/q$ .

### C. Finite Automata

A language over  $\Sigma$  is a subset  $L \subseteq \Sigma^*$ . A finite automaton  $M$  is defined by a quadruple  $M = (\mathcal{G}, \Sigma, I_0, F)$ , where  $\Sigma$  is the input alphabet,  $\mathcal{G} = (V, E, \mathcal{L})$  is a finite-state labeled graph,  $I_0 \in V$  is the initial state, and  $F \subseteq V$  is the set of final states. Elements of  $F$  are *accepting* states of the automaton; any other state is a *non-accepting* state.

An automaton is *deterministic* if  $\mathcal{G}$  is deterministic. A word  $w$  is *accepted* by automaton  $M = (\mathcal{G}, \Sigma, I_0, F)$  if there exists a path  $\pi$  on  $\mathcal{G}$  with  $i(\pi) = I_0$ ,  $t(\pi) \in F$ , and  $\mathcal{L}(\pi) = w$ . The language accepted by the automaton,  $L(M)$ , is the set of words accepted by the automaton. A regular language (or set) is a language accepted by a finite automaton. In a deterministic automaton, there exists a unique path from the initial state to an accepting state that generates each  $w \in L(M)$ .

There is a natural correspondence between languages of sofic shifts and regular languages. The language of a sofic shift is a regular language [16], [18, A.12]. However, not all regular languages are languages of sofic shifts. In particular, if  $M = (\mathcal{G}, \Sigma, I_0, F)$ , then  $L(M)$  does not necessarily equal  $\mathcal{B}(X_{\mathcal{G}})$ . Simple counter-examples may be constructed from graphs with initial or final states that are stranded.

The graph construction algorithm in Section VI-A makes use of the constructive proof that the class of regular languages is closed under complementation; see, e.g., [22, Theorem 3.2]. Hence, if  $L$  is accepted by a finite automaton, then there is a finite automaton that accepts its complement.

## III. PERIODIC-FINITE-TYPE (PFT) SHIFT SPACES

In this section we formally introduce the class of periodic finite-type (PFT) shift spaces and study their relationship to FT shifts and AFT shifts.

### A. Periodic Forbidden Words

In Section II-A, we defined a shift space in terms of a forbidden list  $\mathcal{F}$ . Here, we will define a sequence space in terms of a set of periodically forbidden words. A subtlety is required in the definition to ensure shift invariance.

The notion of periodically forbidden words [14] generalizes the notion of minimal forbidden words (or minimal forbidden factors) of a bi-infinite word (see for instance [23], [24], [25]).

Let  $\Sigma$  be a finite alphabet. Let  $T$  be a positive integer (the *period*), and let  $\mathcal{F} = (\mathcal{F}_0, \mathcal{F}_1, \dots, \mathcal{F}_{T-1})$  be a list of  $T$  possibly empty sets of finite-length words. The list is said to be *regular* (resp. *finite*) if all its sets are regular (resp. finite) sets.

Let  $X_0$  be the set of bi-infinite words  $x$  over  $\Sigma$  such that, for each integer  $i$ , one has

$$u \prec_i x \Rightarrow u \notin \mathcal{F}_{i \bmod T}.$$

Hence, at position  $i$ , the word  $x$  avoids the words in  $\mathcal{F}_{i \bmod T}$ , for all positions  $i$ . A word  $f \in \mathcal{F}_i$  is said to have *phase* equal to  $i$ , and we sometimes denote such a word together with its phase by  $(f, i)$ . The set of all bi-infinite sequences obtained by all integer shifts of words in  $X_0$  defines a subshift  $X$ . The list  $\mathcal{F}$  is called a *periodic forbidden list* of the shift  $X$  for the period  $T$ . Note that the definition of  $X$  depends on the choice of the alphabet  $\Sigma$ .

More formally, we have the following definition.

**Definition 1.** Given a period  $T$  and a periodic forbidden list  $\mathcal{F} = (\mathcal{F}_0, \mathcal{F}_1, \dots, \mathcal{F}_{T-1})$ , The shift  $X = X_{\{\mathcal{F}, T\}}^{\Sigma}$  is defined as the set of all bi-infinite sequences  $x$  over the alphabet  $\Sigma$  such that there exists some integer  $k \in [0, T-1]$  with the property that the  $k$ -shifted sequence  $\sigma^k(x)$  satisfies

$$u \prec_i \sigma^k(x) \Rightarrow u \notin \mathcal{F}_{i \bmod T}$$

for every integer  $i$ . Note that  $k$  may depend upon  $x$ .

Shift invariance of  $X = X_{\{\mathcal{F}, T\}}^{\Sigma}$  is an immediate consequence of the definition. Sometimes we will use the simpler notation  $X_{\{\mathcal{F}, T\}}$  or  $X_{\mathcal{F}}$  to denote the shift  $X$  when the context prevents any confusion.

**Proposition 1.** A shift is a sofic shift if and only if it has a regular periodic forbidden list for any period.

*Proof.* Let  $X$  be a sofic shift over a finite alphabet  $\Sigma$ . Hence  $\mathcal{B}(X)$  is a regular language. For any positive integer  $T$ , the list  $\mathcal{F}$  defined by  $\mathcal{F}_i = \Sigma^* - \Sigma^* \mathcal{B}(X) \Sigma^*$ , for any  $0 \leq i \leq T-1$ , is a regular periodic forbidden list of  $X$  for the period  $T$ .

Conversely, suppose  $X = X_{\{\mathcal{F}, T\}}$  for a period  $T$  where  $\mathcal{F}_i$  is a regular language for any  $0 \leq i \leq T-1$ . Let  $\mathcal{G}$  be a finite-state automaton accepting the regular language  $W = \Sigma^* - \bigcup_{i=0}^{T-1} (\Sigma^T)^* \Sigma^i \mathcal{F}_i \Sigma^*$ . The finite-state labeled graph obtained from this automaton by removing the non-final states of  $\mathcal{G}$  and by keeping its essential part (*i.e.* the states belonging to a bi-infinite path) is a presentation of the shift  $X$ . ■

It follows from the definition that the list

$$\mathcal{F}' = (\mathcal{F}_{T-1}, \mathcal{F}_0, \dots, \mathcal{F}_{T-2})$$

formed by adding one, modulo  $T$ , to the phase of each  $(f, i)$  pair in  $\mathcal{F}$ , satisfies  $X_{\{\mathcal{F}, T\}} = X_{\{\mathcal{F}', T\}}$ . We refer to the periodic forbidden lists obtained by repeated application of this procedure as the *conjugates* of the list  $\mathcal{F}$ .

### B. PFT Shifts

A shift space  $X$  is *periodic finite-type (PFT)* for a positive integer period  $T$  if it can be described as  $X = X_{\{\mathcal{F}, T\}}^{\Sigma}$ , where  $\mathcal{F}$  is a *finite* periodic forbidden list  $\mathcal{F} = (\mathcal{F}_0, \mathcal{F}_1, \dots, \mathcal{F}_{T-1})$ .

We say that such a shift  $X$  is PFT( $T$ ). Note that a shift is finite-type if and only if it is PFT(1).

**Example 1** Consider the PFT sofic shift  $X$  over the alphabet  $\{0, 1\}$  presented by the graph shown in Fig. 1. For  $T = 2$ , the shift  $X$  has the periodic forbidden list  $\mathcal{F} = (\mathcal{F}_0, \mathcal{F}_1)$ , with  $\mathcal{F}_0 = \{1\}, \mathcal{F}_1 = \emptyset$ .

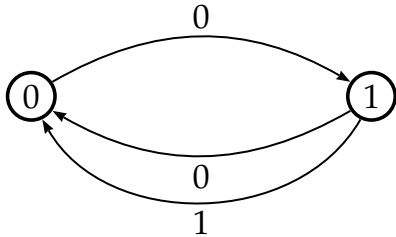

Fig. 1. The periodic finite type shift  $X_{\mathcal{F}}$  for the period 2 over  $\{0, 1\}$  with  $\mathcal{F}_0 = \{1\}, \mathcal{F}_1 = \emptyset$ .

It is easy to see that, for a PFT( $T$ ) shift  $X_{\mathcal{F}}$  over the alphabet  $\Sigma$ , one can construct a periodic forbidden list  $\mathcal{F}'$  in which all words have the same phase, the same length, or both. A common phase is obtained by taking each word  $f \in \mathcal{F}_i$ , prepending each of the  $|\Sigma|^i$  prefixes of length  $i$  to  $f$ , and associating phase 0 with each of the resulting words. The sets corresponding to the other phases are defined to be empty sets. A common word length is achieved by replacing each  $f$  in  $\mathcal{F}_i$  with the words obtained by appending each of the  $|\Sigma|^{l-|f|}$  suffixes to  $f$ , where  $l \geq \max_{f \in \mathcal{F}} |f|$ , so that each word has length  $l$ . Finally, a list that satisfies both properties may be constructed by applying the first transformation followed by the second.

### C. PFT Sofic Shifts

The following theorem, an analog to [16, Theorem 3.1.5] for shifts of finite type, establishes that PFT shift spaces are sofic shifts by explicitly constructing a presentation.

**Theorem 2.** *Every periodic-finite-type shift space is sofic.*

*Proof.* Let  $X_{\mathcal{F}}$  be a PFT( $T$ ) shift space. Assume, without loss of generality, that  $\mathcal{F}_i = \emptyset$  for  $i = 1, \dots, T-1$ , and that each word  $w \in \mathcal{F}_0$  has length  $|w| = l$ .

For  $l \geq 1$ , let  $\mathcal{U}(l)$  be the graph with vertex set  $\mathcal{V}(\mathcal{U}(l)) = \Sigma^l$ , the set of all  $l$ -blocks of letters from  $\Sigma$ . For each pair of vertices  $I = a_1 a_2 \dots a_l$  and  $J = b_1 b_2 \dots b_l$  in  $\mathcal{V}(\mathcal{U}(l))$  with  $a_2 a_3 \dots a_l = b_1 b_2 \dots b_{l-1}$ , draw an edge from  $I$  to  $J$  with label  $b_l$ .

Let  $\mathcal{U}(l, T)$  be the  $T$ -cascade of  $\mathcal{U}(l)$  with vertex sets  $\mathcal{V}_0, \mathcal{V}_1, \dots, \mathcal{V}_{T-1}$ . Let  $\mathcal{U}(l, T, \mathcal{F})$  be the graph formed from  $\mathcal{U}(l, T)$  by deleting the edges starting and ending at each vertex  $I = a_1 a_2 \dots a_l \in \mathcal{V}_l \bmod T$  such that  $I = w$  where  $w \in \mathcal{F}_0$ , as well as the vertex itself.

Let  $\mathcal{G}$  be the largest essential subgraph of  $\mathcal{U}(l, T, \mathcal{F})$ . We will show that  $X_{\mathcal{F}} = X_{\mathcal{G}}$ . Choose  $x = \mathcal{L}_{\infty}(\dots e_{-1} e_0 e_1 \dots) \in X_{\mathcal{G}}$ . Suppose that  $i(e_0) \in \mathcal{V}_k \cap \mathcal{V}(\mathcal{G})$ .

Let  $y = \sigma^k(x)$ . Then  $y_{[m, m+l-1]} \neq w$  for each  $w \in \mathcal{F}$  and  $m \in \mathbb{Z}$  with  $m \bmod T = 0$ . Therefore  $y \in X_{\mathcal{F}}$  and we conclude that  $X_{\mathcal{G}} \subseteq X_{\mathcal{F}}$ .

To show the reverse inclusion, choose  $x \in X_{\mathcal{F}}$ , and let  $k$  be an integer such that  $y = \sigma^k(x)$  satisfies  $y_{[m, m+l-1]} \neq w$  for each  $w \in \mathcal{F}$  and  $m \in \mathbb{Z}$  with  $m \bmod T = 0$ . Since  $\mathcal{U}(l, T)$  presents  $\Sigma^{\mathbb{Z}}$ ,  $y$  is the label of a walk on  $\mathcal{U}(l, T)$ . Let  $\xi = (\dots e_{-1} e_0 e_1 \dots)$  be the walk on  $\mathcal{U}(l, T)$  such that  $\mathcal{L}_{\infty}(\xi) = y$  and  $i(e_0) \in \mathcal{V}_0$ . Suppose an edge in  $\xi$  is deleted when constructing  $\mathcal{G}$  (so that  $y \notin X_{\mathcal{G}}$ ). This occurs only if  $y_{[m, m+l-1]} = w$  for some  $w \in \mathcal{F}$  and  $m \in \mathbb{Z}$  with  $m \bmod T = 0$ , contradicting the properties of  $y$ . Therefore  $x \in X_{\mathcal{G}}$  and  $X_{\mathcal{F}} \subseteq X_{\mathcal{G}}$ . ■

The constructive proof of Theorem 2 provides a method to obtain a graph presenting a PFT shift. The drawback of using the method in practice is the size of the initial representation, which grows exponentially with the length of the longest element in  $\mathcal{F}$ . In Section VI, we discuss alternative algorithms for generating graph presentations of a PFT shift.

The construction in Theorem 2 actually implies a stronger result, namely, that any PFT shift is AFT.

**Theorem 3.** *Irreducible PFT shifts are AFT.*

*Proof.* Let  $X_{\{\mathcal{F}, T\}}$  be a PFT( $T$ ) shift over the alphabet  $\Sigma$ . It is easy to see that the graph  $\mathcal{G}$  constructed in Theorem 2 is deterministic. Therefore, to prove that  $X_{\{\mathcal{F}, T\}}$  is AFT, it suffices to show that  $\mathcal{G}$  has finite local memory. In fact, since  $\mathcal{G} \subseteq \mathcal{U}(l, T)$ , and the operation of passing to a subgraph preserves the property of finite local memory, it suffices to verify that  $\mathcal{U}(l, T)$  has this property. Without loss of generality, consider a vertex  $I \in \mathcal{V}_0$ , with  $I = (a_1 a_2 \dots a_l)$ . Let  $\pi = e_0 e_1 \dots e_l$  and  $\pi' = e'_0 e'_1 \dots e'_l$  be two paths of length  $l+1$  that terminate in  $I$  and generate the word  $b_0 b_1 \dots b_l$ . Let  $J = i(e_l)$  and  $J' = i(e'_l)$ . From the definition of  $\mathcal{U}(l, T)$ , it follows that  $J \in \mathcal{V}_{T-1}$  and  $J' \in \mathcal{V}_{T-1}$ , and, moreover, both  $J$  and  $J'$  correspond to the state  $b_0 b_1 \dots b_{l-1} = b_0 a_1 a_2 \dots a_{l-1}$ . The edge from this state to state  $I$  with label  $a_l$  is unique, implying that  $e_l = e'_l$ . Thus  $\mathcal{U}(l, T)$  has finite local memory. ■

The sliding block coding theorem [16, Theorem 5.5.6] holds for AFT systems [26]. Therefore there exist sliding-block-decodable finite-state codes into irreducible PFT shifts at rational rates less than or equal to the Shannon capacity of the shift. (In Section VI, we address the computation of the capacity of PFT shifts.)

### D. Proper PFT Shifts

We further distinguish a PFT shift as *proper* if it is not FT. For any proper PFT shift, there exists a word that is allowed in some, but not all, phases. Hence proper PFT shifts are PFT( $p$ ) only for  $p > 1$ . The PFT(2) shift of Example 1 is proper. Here are two further examples of proper PFT constraints that have found practical application in magnetic recording systems. Historically, these constraints provided the motivation for the definition and study of PFT shifts.

**Example 2** The well-known biphasic shift is a PFT(2) shift over the binary alphabet with  $\mathcal{F}_0 = \{00, 11\}$  and  $\mathcal{F}_1 = \emptyset$ . Fig. 2 illustrates  $\mathcal{U}(l, T, \mathcal{F})$ , as described in the proof of Theorem 2, where the cyclic nature of the cascade is represented by re-drawing  $\mathcal{V}_1$ . Deleted edges and states are drawn with

dashed lines. The Shannon cover is illustrated in Fig. 3. It is easily shown and well known that the biphasic shift is not FT (see, for example, [16, Theorem 3.4.17], [17, p. 1657]) and hence is proper PFT. ■

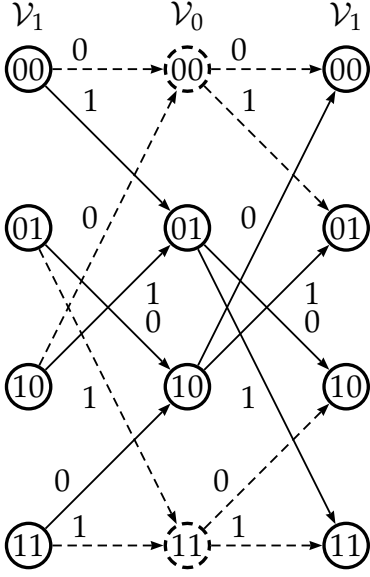

Fig. 2.  $U(l, T, \mathcal{F})$  presenting the biphasic shift.

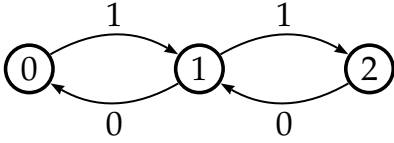

Fig. 3. Shannon cover of the biphasic constraint.

**Example 3** The time-varying maximum-transition-run (TMTR) shift [2], [3], [4] is a binary PFT(2) shift with  $\mathcal{F}_0 = \{111\}$  and  $\mathcal{F}_1 = \emptyset$ . The Shannon cover is shown in Fig. 4. It is easy to verify the TMTR shift is not FT; for example, note that the Shannon cover contains the cover for the biphasic shift, Fig. 3, as a subgraph. Therefore it cannot be definite, implying that the TMTR shift is a proper PFT shift. ■

#### E. Periods of PFT Shifts

We now explore the periods  $T$  with which a PFT shift can be associated.

**Lemma 4.** *If  $X$  is an irreducible PFT( $T$ ) shift, then  $X$  is PFT( $nT$ ) for any positive integer  $n$ .*

*Proof.* If  $X = X_{\mathcal{F}}$  with  $\mathcal{F} = (\mathcal{F}_0, \mathcal{F}_1, \dots, \mathcal{F}_{T-1})$ , then we have trivially also  $X = X_{\mathcal{E}}$  with  $\mathcal{E} = (\mathcal{E}_i)_{0 \leq i \leq nT-1}$  and  $\mathcal{E}_i = \mathcal{F}_{i \bmod T}$ . ■

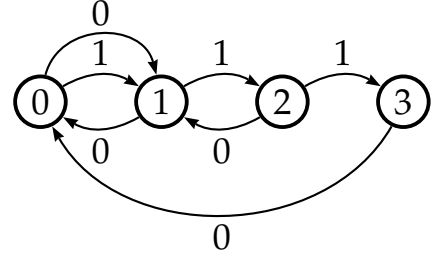

Fig. 4. Shannon cover of the TMTR shift.

**Proposition 5.** *If  $X$  is an irreducible PFT( $T$ ) shift which has an irreducible presentation of period  $q$ , then  $X$  is PFT( $\gcd(T, q)$ ).*

*Proof.* Let  $X = X_{\mathcal{F}}$  with  $\mathcal{F} = (\mathcal{F}_0, \mathcal{F}_1, \dots, \mathcal{F}_{T-1})$ . Let  $d = \gcd(T, q)$  and  $k = T/d$ . Let  $Y = X_{\mathcal{E}}$  with  $\mathcal{E} = (\mathcal{E}_0, \mathcal{E}_1, \dots, \mathcal{E}_{d-1})$  and  $\mathcal{E}_i = \cup_{j=0}^{k-1} \mathcal{F}_{i+jd}$ . It is straightforward to see that  $Y \subseteq X$ .

Let us assume that there is a bi-infinite sequence  $x$  in  $X - Y$ . It is no loss of generality to take as  $x$  a periodic sequence. Since  $x \notin Y$ , for each integer  $0 \leq l \leq d-1$ , there are integers  $0 \leq i \leq d-1$ ,  $0 \leq j \leq k-1$ , a positive integer  $n$ , and a finite factor  $u$  of  $x$  at position  $l + nd + i$  such that  $u \in \mathcal{F}_{i+jd}$ . Moreover, since  $x$  is periodic, one may assume without loss of generality that the distance between two positions  $l + nd + i$  is greater than the maximal length of the words in the list  $\mathcal{F}$ . Let  $\pi$  be a path labeled by  $x$  in the irreducible presentation of  $X$  of period  $q$ . Let  $I$  be the state in  $\pi$  at position  $l + nd + i$ . Since the presentation is irreducible and of period  $q$ , there is a positive integer  $N$  such that for any nonnegative integer  $r$  there is a cycle around  $I$  of length  $NTq + rq$ . Since  $\gcd(T, q) = d$ , there are integers  $a, b$  such that  $aT = -bq + d$ . One can moreover choose  $b > 0$ . Let  $M$  be a positive integer such that  $b(j-n) + MT > 0$ . We choose  $r = b(j-n) + MT$ . Hence there is a cycle around  $I$  of size  $Z = NTq + b(j-n)q + MTq$ . Its length is thus equal to  $jd - nd \bmod T$ . The bi-infinite sequence labeling a path obtained from  $x$  by inserting this cycle at position  $l + nd + i$  belongs to  $X$ . At the position  $l + nd + i + Z$ , equal to  $l + i + jd \bmod T$ , this sequence contains a factor in  $\mathcal{F}_{i+jd \bmod T}$ . By inserting such cycles simultaneously into  $x$  at all positions  $l + nd + i$ , we get a sequence such that every shift of this sequence by  $l$  positions has a factor at a position equal to  $i + jd \bmod T$  which belongs to  $\mathcal{F}_{i+jd}$ . Hence  $x \notin X$ , which is a contradiction. ■

Let  $\mathcal{G}$  be a presentation of a PFT( $T$ ) shift  $X_{\mathcal{F}}$ . The following proposition gives a condition that can be used to determine if  $X_{\mathcal{F}}$  is not a proper PFT shift, namely, the period of  $\mathcal{G}$  and the period  $T$  associated with the forbidden list must share a nontrivial common factor.

**Proposition 6.** *If  $\mathcal{G}$  is an irreducible presentation of a proper PFT( $T$ ) shift  $X_{\mathcal{F}}$  over an alphabet  $\Sigma$ , then  $\gcd(\text{per}(\mathcal{G}), T) \neq 1$ .*

*Proof.* Suppose that  $\gcd(\text{per}(\mathcal{G}), T) = 1$ . Since  $X_{\mathcal{F}}$  is proper, there exists a word  $w \in \mathcal{F}$  and a state  $I \in \mathcal{V}(\mathcal{G})$  such that  $w \in F_{\mathcal{G}}(I)$ . From the irreducibility of  $\mathcal{G}$ , we can choose a word  $v$  such that the path presenting  $wv$  is a cycle. Choose a

cycle  $\pi$  with  $i(\pi) = I$  such that  $T$  and  $l = |\pi|$  have no common divisors greater than 1. Let  $u = \mathcal{L}(\pi)$ . One can choose positive integers  $q_0, q_1, \dots, q_{T-1}$  such that

$$x = \dots wvu^{q_0}wvu^{q_1} \dots wvu^{q_{T-1}} \dots$$

is the label of a walk on  $\mathcal{G}$  and  $w$  appears in  $x$  at all phases  $0, \dots, T-1$ . This implies  $x \notin X_{\mathcal{F}}$ , a contradiction. Hence  $\gcd(\text{per}(\mathcal{G}), T) \neq 1$  ■

The following corollary is an immediate consequence.

**Corollary 7.** *Let  $X$  be an irreducible PFT( $T$ ) shift for some period  $T$ . Let  $\mathcal{G}$  be an irreducible presentation of  $X$ . If  $\gcd(\text{per}(\mathcal{G}), T) = 1$ , then  $X$  is FT.*

■

Note that the PFT shifts in Examples 2 and 3 above – the biphasic and TMTR shifts – are not FT. The period associated with each of their respective forbidden lists is  $T = 2$ , and the graph period of each of their respective Shannon covers is also 2. Hence,  $\gcd(\text{per}(\mathcal{G}), 2) = 2 \neq 1$ , in accordance with Proposition 6.

**Example 4** The graph  $\mathcal{G}$  in Fig. 5 is the Shannon cover of a shift that we will refer to as the *abcd shift*. The *abcd shift* is clearly FT, and therefore not proper PFT. Since any FT shift may be described as a PFT( $T$ ) shift for arbitrary period  $T$  by assigning all phases  $0, 1, \dots, T-1$  to each word in a finite forbidden list, we may choose  $\mathcal{F} = (\mathcal{F}_0, \mathcal{F}_1)$  such that  $X_{\mathcal{G}} = X_{\mathcal{F}}$  is PFT(2). Since  $\text{per}(\mathcal{G}) = 2$ ,  $\gcd(\text{per}(\mathcal{G}), T) = 2$ . This demonstrates that the converse of Proposition 6 is not true. ■

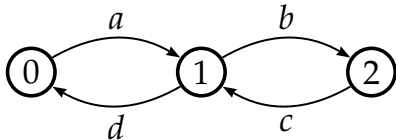

Fig. 5. Graph presenting the *abcd shift*.

**Example 5** Fig. 6 illustrates a graph that presents valid  $(d, k)$  sequences. Aside from the trivial case where  $d = k$ , we find  $\text{per}(\mathcal{G}) = 1$ ; hence  $(d, k)$  shifts are not proper PFT. ■

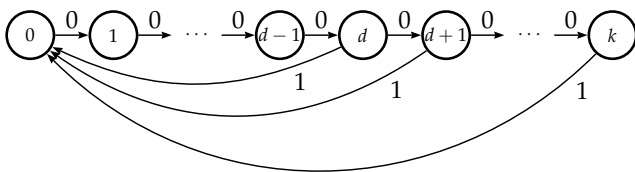

Fig. 6. Graph presenting the  $(d, k)$  shifts.

The following example shows that not all AFT shifts are PFT shifts.

**Example 6** Fig. 7 is the Shannon cover of the *even shift*, so called because its bi-infinite sequences contain only even numbers of consecutive 0's. It is easily verified that the even shift is AFT but not FT. By inspection, we see that  $\text{per}(\mathcal{G}) = 1$ . Therefore, by Corollary 7, the even shift is not PFT( $T$ ) for any  $T \geq 1$ . ■

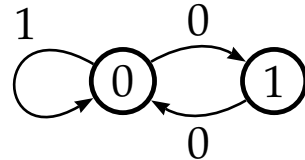

Fig. 7. Shannon cover of the even shift.

Example 6 shows that the PFT shift spaces are a proper subset of the AFT shift spaces.

Manada and Kashyap [27] have examined the relationship between the period  $T$  inherent in the definition of a PFT shift  $X = X_{\{\mathcal{F}, T\}}$  and properties of the shift. They also study the relationship of this *descriptive* period to the periods of periodic sequences in  $X$  and to the periods of its graphical presentations.

#### IV. CHARACTERIZATION AND DECIDABILITY

In this section, we further characterize PFT shifts in terms of properties of their presentations. The characterizations imply the decidability of the PFT property, and they suggest a testing algorithm that is quadratic in the number of states of the Shannon cover.

##### A. Graphical Characterization

The following proposition proves the decidability of the PFT property for an irreducible sofic shift.

**Proposition 8.** *Let  $X$  be an irreducible sofic shift,  $\mathcal{G}$  its Shannon cover of period  $q$ , and  $T$  a positive integer. Then the following assertions are equivalent.*

- 1)  $X$  is PFT( $T$ ).
- 2) The irreducible components of  $\mathcal{G}^{\gcd(T, q)}$  are definite graphs.

*Proof.* Let us assume that  $X$  is PFT( $T$ ). Let  $q$  be the period of the Shannon cover of  $X$  and  $d = \gcd(T, q)$ . By Lemma 5,  $X$  is PFT( $d$ ). We prove that the irreducible components of  $\mathcal{G}^d$  are definite. Let  $C$  be one of these components. Let  $C$  has two distinct cycles with the same label, one around a state  $I$ , another around a state  $J$  distinct from  $I$ . Hence there is in  $\mathcal{G}$  a cycle around  $I$  (resp.  $J$ ) labeled by a word  $u$  of length  $nd$  for some positive integer  $n$ . Since  $I$  and  $J$  belong to a common irreducible component of  $\mathcal{G}^d$ , there is a path labeled by  $z$  from  $I$  to  $J$  in  $\mathcal{G}$  of length  $md$  for some positive integer  $m$ . Let  $v$



be a left-infinite sequence ending with a synchronizing word that focuses to  $I$  in  $\mathcal{G}$ . Since  $\mathcal{G}$  is the Shannon cover of  $X$ , the states  $I$  and  $J$  have different follower sets. Let  $f_J$  be a right-infinite sequence generated by some path in  $\mathcal{G}$  starting at  $J$  that is not the label of a path starting at  $I$ . For any nonnegative integer  $N$ , the bi-infinite word  $x = vu^N zu^N f_J$  belongs to  $X$ . Since  $X$  is PFT( $d$ ), this implies that, for a large enough  $N$ ,  $x' = vu^N f_J$  belongs to  $X$ , which is a contradiction of the fact that  $f_J$  is not generated by a path starting at  $I$ .

Conversely, let us assume that each irreducible component  $C$  of  $\mathcal{G}^d$  is a definite graph. Since  $\mathcal{G}$  has period  $q$ , one can order the irreducible components of  $\mathcal{G}^d$  into  $(C_0, C_1, \dots, C_{d-1})$ , such that there is at least one edge from some state in  $C_i$  to some state in  $C_{i+1 \bmod d}$  in  $\mathcal{G}$ . Each component  $C_i$  presents a shift of finite type  $X_{\mathcal{F}_i}$  over the alphabet  $B = \Sigma^d$ , where  $\mathcal{F}_i$  is a finite subset of  $B^*$ . Let  $\mathcal{E}_i$  be the set of words in  $\mathcal{F}_i$  with symbols in the alphabet  $\Sigma$ . Let  $Y = X_{\mathcal{E}}$  with  $\mathcal{E} = (\mathcal{E}_0, \mathcal{E}_1, \dots, \mathcal{E}_{d-1})$ . By construction  $X = Y$ . It follows that  $X$  is PFT( $d$ ) and also, by Lemma 4, PFT( $T$ ). ■

**Corollary 9.** *Let  $X$  be an irreducible sofic shift and  $p$  be the period of the Shannon cover  $\mathcal{G}$  of  $X$ . Then the following assertions are equivalent.*

- 1)  $X$  is PFT.
- 2)  $X$  is PFT( $p$ ).
- 3) The irreducible components of  $\mathcal{G}^p$  are definite graphs.

*Proof.* (2)  $\Leftrightarrow$  (3) comes from Proposition 8. We prove (1)  $\Rightarrow$  (2). If  $X$  is PFT( $T$ ) for some positive integer  $T$ , we get from Lemma 5 that  $X$  is PFT( $\gcd(p, T)$ ). It is then also PFT( $p$ ) by Lemma 4. Finally (2)  $\Rightarrow$  (1) follows from the definition of a PFT shift. ■

**Corollary 10.** *Let  $\mathcal{G}$  be irreducible with period  $T$ . If an irreducible component  $\mathcal{H}$  of  $\mathcal{G}^T$  is FT with  $X_{\mathcal{H}}^{\Sigma^T} = X_{\mathcal{F}'}^{\Sigma^T}$ , then  $X_{\mathcal{G}} = X_{\{\mathcal{F}, \mathcal{T}\}}$  where  $\mathcal{F}_0 = \mathcal{F}'$  and  $\mathcal{F}_i = \emptyset$ , for  $i = 1, \dots, T - 1$ . ■*

**Example 7** The Shannon cover of the *interleaved-biphase* shift is illustrated in Fig. 8. The period of the graph is 4, and one can show the irreducible components of  $\mathcal{G}^4$  are finite-type. In particular, if  $\mathcal{H}$  denotes the irreducible component consisting of the central state in Fig. 8, then  $X_{\mathcal{H}} = X_{\mathcal{F}'}$ , where

$$\mathcal{F}' = \{0000, 0001, 0010, 0100, 0101, 0111, 1000, 1010, 1011, 1101, 1110, 1111\}.$$

Hence the interleaved-biphase shift is PFT(4), with  $\mathcal{F}_0 = \mathcal{F}'$  and  $\mathcal{F}_1 = \mathcal{F}_2 = \mathcal{F}_3 = \emptyset$ . ■

### B. Decidability of PFT Property

We now derive from the previous propositions a quadratic-time algorithm to check whether an irreducible sofic shift presented by its Shannon cover is PFT.

**Proposition 11.** *Let  $X$  be an irreducible sofic shift presented by its  $n$ -state Shannon cover. It is decidable in time  $O(n^2 \times \log |\Sigma|)$  whether  $X$  is PFT.*

*Proof.* Let  $\mathcal{G}$  be the irreducible Shannon cover of  $X$ . One first computes the period  $p$  of  $\mathcal{G}$ . This operation can be performed with one depth-first search of the graph of  $\mathcal{G}$  in time  $O(n \log n \times |\Sigma|)$  (see [28], [29]).

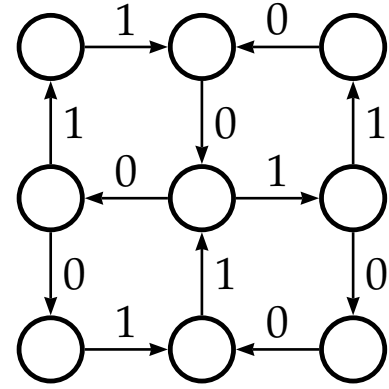

Fig. 8. Shannon cover of interleaved-biphase shift.

Since  $\mathcal{G}$  has period  $p$ , one can define a coloring function  $c$  from  $\mathcal{V}(\mathcal{G})$  to  $\{0, 1, \dots, p - 1\}$  such that, whenever there is an edge from a state  $I$  to a state  $J$ ,  $c(J) = c(I) + 1 \bmod p$ . The color of each state can be computed through a depth-first-search of the graph of  $\mathcal{G}$  in time  $O(n)$ .

One then computes the *fiber product* graph  $\mathcal{H} = \mathcal{G} * \mathcal{G}$  whose set of states is the set of pairs  $(I, J)$ , where  $I, J$  are states of  $\mathcal{G}$  [17]. There is an edge labeled by  $a$  from  $(I, J)$  to  $(I', J')$  if and only if there are two edges labeled by  $a$  from  $I$  to  $I'$  and from  $J$  to  $J'$ . The graph  $\mathcal{H}$  is deterministic over  $\Sigma$  and has at most  $n^2$  states. Then  $X$  is PFT if and only if there is no cycle in  $\mathcal{H}$  going through a state  $(I, J)$  with  $I \neq J$  and  $I, J$  having the same color. Indeed, the existence of such a cycle is equivalent to the existence of two identically labeled cycles in  $\mathcal{G}^p$ , one starting at  $I$ , the other one at  $J$  with  $I \neq J$  and  $I, J$  in the same irreducible component of  $\mathcal{G}^p$ . The existence of such cycles can be determined in time that is linear in the size  $n^2$  of  $\mathcal{H}$ , for instance by inspection of the irreducible components of  $\mathcal{H}$ . The final worst case time-complexity is therefore  $O(n^2 \times \log |\Sigma|)$ . ■

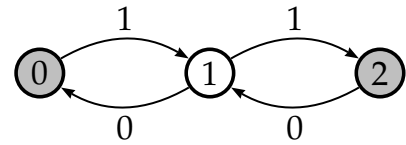

Fig. 9. A 2-coloring of the Shannon cover of the biphase shift.

**Example 8** Let us consider again the biphase shift of Example 2. The Shannon cover, shown in Fig. 9, has period 2. For any 2-coloring, the states 0 and 2 have the same color while 1 has a different color, as illustrated. The cover  $\mathcal{H}$  is represented

in Fig. 10. (States  $(0,2)$  and  $(2,0)$  are not shown, as there are no edges in  $\mathcal{H}$  starting or ending in these states.) Since the cycles go only through pairs of states with different colors or through pairs with the same color but also with equal states, we conclude that the biphasic shift is PFT.

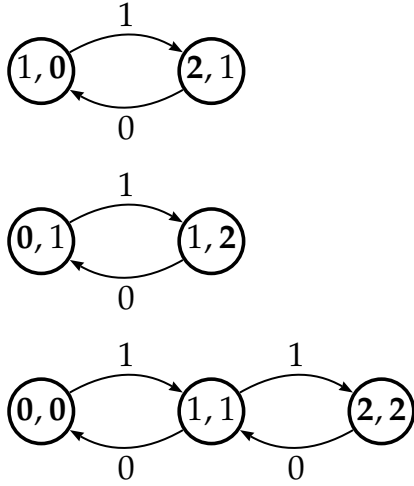

Fig. 10. Graph  $\mathcal{H}$  for checking if the biphasic constraint is PFT. Names of shaded states are shown in bold font. Stranded states are not shown.

## V. PERIODIC FIRST OFFENDERS

In this section, we define a notion of minimal periodic forbidden list of a PFT shift for a given period.

Let  $\mathcal{F} = (\mathcal{F}_0, \mathcal{F}_1, \dots, \mathcal{F}_{T-1})$  be a periodic forbidden list of a shift  $X$  for some positive period  $T$ . We say that  $\mathcal{F}$  is *periodic anti-factorial* if and only if for any  $0 \leq i \leq T-1$  and any  $j \geq 0$ ,

$$w \in \mathcal{F}_i \text{ and } u \prec_j w \text{ with } u \neq w \implies u \notin \mathcal{F}_{i+j \bmod T}.$$

The notion of periodic anti-factorial list was introduced in [13]. It generalizes the notion of anti-factorial language (see [24]). In particular, the sets  $\mathcal{F}_i$  of a periodic anti-factorial list are prefix-free and suffix-free codes.

**Example 9** The list

$$\begin{aligned} \mathcal{F}_0 &= \{00, 11\} \\ \mathcal{F}_1 &= \{00, 11, 010\}, \end{aligned}$$

with  $T = 2$  is periodic anti-factorial, while the list

$$\begin{aligned} \mathcal{F}_0 &= \{00, 11, 010\} \\ \mathcal{F}_1 &= \{00, 10\}, \end{aligned}$$

with  $T = 2$  is not periodic anti-factorial. Indeed, in the latter list,  $010 \in \mathcal{F}_0$ ,  $10 \in \mathcal{F}_1$ , and  $10 \prec_1 010$ .

For any regular periodic forbidden list  $\mathcal{F}$  of a shift  $X$ , there is a regular and periodic anti-factorial forbidden list  $\mathcal{F}'$  of  $X$  such that  $\mathcal{F}'_i \subseteq \mathcal{F}_i$  for any  $0 \leq i \leq T-1$ . Indeed, one can

choose

$$\begin{aligned} \mathcal{F}'_i &= \mathcal{F}_i - \mathcal{F}_i \Sigma^+ - (\Sigma^T)^+ \mathcal{F}_i \Sigma^* \\ &\quad - \bigcup_{j=1}^{T-1} (\Sigma^T)^* \Sigma^j \mathcal{F}_{i+j \bmod T} \Sigma^*. \end{aligned}$$

Periodic anti-factorial lists do not seem to satisfy any useful kind of minimality property among periodic forbidden lists of a PFT shift. We consider, instead, periodic forbidden lists based upon sets of periodic forbidden words called *periodic first offenders* that were introduced in [14], [15]. Their definition is intended to mimic that of the *first offenders* of a shift  $X$  [18] and to refine the notion of periodic anti-factorial list. A key difference, however, is that their definition is not intrinsic; rather, it refers specifically to a presentation of the sofic shift.

We first recall the key properties of the set of first offenders. A word  $w$  is a *first offender* for a shift  $X$  if  $w \notin \mathcal{B}(X)$  but every proper subword of  $w$  is in  $\mathcal{B}(X)$ . The collection of first offenders,  $\mathcal{O}$ , describes the space,  $X = X_{\mathcal{O}}$ , and satisfies the following minimality properties [18], [16, Exercises 1.3.8, 2.1.10]:

- (1) if  $\mathcal{F} \subseteq \mathcal{O}$  and  $X_{\mathcal{F}} = X$ , then  $\mathcal{F} = \mathcal{O}$ ,
- (2) if  $\mathcal{F}$  is finite and  $X_{\mathcal{F}} = X$ , then  $\sum_{w \in \mathcal{O}} |w| \leq \sum_{w \in \mathcal{F}} |w|$ .

Clearly, the words in  $\mathcal{O}$  form an anti-factorial list.

We now introduce an analogous construction for the periodic scenario. Let  $\mathcal{G}$  be an irreducible presentation of period  $p$  of an irreducible sofic shift  $X$ . The states  $\mathcal{V}$  of  $\mathcal{G}$  are colored in  $p$  colors by a coloring function  $c : \mathcal{V} \rightarrow \{0, 1, \dots, p-1\}$ . One has  $c(J) = c(I) + 1 \bmod p$  whenever there is an edge from  $I$  to  $J$ . We denote by  $\mathcal{V}_i$  the set of states of color  $i$ , for  $0 \leq i \leq p-1$ . We also say that these states are *in phase*  $i$ . We denote by  $\mathcal{F}(\mathcal{G}, c)$  the list  $\mathcal{F} = (\mathcal{F}_i)_{0 \leq i \leq p-1}$  where the sets  $\mathcal{F}_i$  are the sets of finite words  $w = w_{[0, |w|-1]}$  such that

- 1)  $w \notin F_{\mathcal{G}}(\mathcal{V}_i)$ ,
- 2) for any  $0 \leq j < |w| - 1$ ,  $w_{[0, j]} \in F_{\mathcal{G}}(\mathcal{V}_i)$ ,
- 3) for any  $0 < j \leq |w| - 1$ ,  $w_{[j, |w|-1]} \in F_{\mathcal{G}}(\mathcal{V}_{i+j \bmod p})$ .

Note that the second condition can be replaced by  $w_{[0, |w|-2]} \in F_{\mathcal{G}}(\mathcal{V}_i)$ , and the third one can be replaced by  $w_{[1, |w|-1]} \in F_{\mathcal{G}}(\mathcal{V}_{i+1 \bmod p})$ . Hence, for  $0 \leq i \leq p-1$ , the sets  $\mathcal{F}_i$  can also be defined by

$$\mathcal{F}_i = (\Sigma^* - F_{\mathcal{G}}(\mathcal{V}_i)) \cap (F_{\mathcal{G}}(\mathcal{V}_i) \Sigma) \cap (\Sigma F_{\mathcal{G}}(\mathcal{V}_{i+1 \bmod p})).$$

Note also that, when  $c$  is changed into another coloring of the graph in  $p$  colors, the list  $\mathcal{F}(\mathcal{G}, c) = (\mathcal{F}_0, \mathcal{F}_1, \dots, \mathcal{F}_{p-1})$  is changed into one of its conjugates  $(\mathcal{F}_j, \mathcal{F}_{j+1}, \dots, \mathcal{F}_{p-1}, \mathcal{F}_0, \dots, \mathcal{F}_{j-1})$ .

**Proposition 12.** *Let  $\mathcal{G}$  be an irreducible presentation with a coloring of its states  $c$  in  $p$  colors. The list  $\mathcal{F}(\mathcal{G}, c)$  is a regular and anti-factorial periodic forbidden list of the sofic shift presented by  $\mathcal{G}$ .*

*Proof.* Let  $\mathcal{F} = \mathcal{F}(\mathcal{G}, c)$ . It follows from the definitions that  $X \subset X_{\mathcal{F}}$ . Conversely, let  $x \in X_{\mathcal{F}}$ . We will show that every subword of  $x$  is in  $\mathcal{B}(X)$ . Up to a power of the shift of the sequence  $x$ , for any integers

$i, j$ , we have  $x_{[i,j]} \notin \mathcal{F}_i \bmod p$ . We prove by recurrence on  $j$  that  $x_{[i,j]} \in F_{\mathcal{G}}(\mathcal{V}_i)$  and  $x_{[i+1,j]} \in F_{\mathcal{G}}(\mathcal{V}_{i+1})$  for any  $j \geq i$ . Since  $x_{[i]} \notin \mathcal{F}_i$  and  $x_{[i+1]} \notin \mathcal{F}_{i+1}$ , we have  $x_{[i]} \in F_{\mathcal{G}}(\mathcal{V}_i)$  and  $x_{[i+1]} \in F_{\mathcal{G}}(\mathcal{V}_{i+1})$ . By definition of  $\mathcal{F}_i$ , from  $x_{[i,i+1]} \notin \mathcal{F}_i$ , we get  $x_{[i,i+1]} \in F_{\mathcal{G}}(\mathcal{V}_i)$ . Let us now assume that  $x_{[i,j]} \in F_{\mathcal{G}}(\mathcal{V}_i)$  and  $x_{[i+1,j]} \in F_{\mathcal{G}}(\mathcal{V}_{i+1})$ . By definition of  $\mathcal{F}_i$ , we get  $x_{[i,j+1]} \in F_{\mathcal{G}}(\mathcal{V}_i)$ . This implies also  $x_{[i+1,j+1]} \in F_{\mathcal{G}}(\mathcal{V}_{i+1})$ . Thus, any subword of  $x$  belongs to  $\mathcal{B}(X)$ . This shows that  $x \in X$ . It is clear that  $\mathcal{F}(\mathcal{G}, c)$  is anti-factorial. ■

We denote by  $\text{size}(\mathcal{F})$  the size of a periodic forbidden list  $\mathcal{F}$  for a period  $p$ . It is defined by

$$\text{size}(\mathcal{F}) = \sum_{0 \leq i \leq p-1} \sum_{w \in \mathcal{F}_i} |w|.$$

**Proposition 13.** *Let  $X$  be an irreducible sofic shift and  $\mathcal{G}$  be an irreducible presentation of  $X$  with a  $p$ -coloring  $c$ . Let  $\mathcal{F}$  be any regular periodic forbidden list of  $X$  for the period  $p$ . If  $\mathcal{F}$  is finite,  $\mathcal{F}(\mathcal{G}, c)$  is finite and  $\text{size}(\mathcal{F}(\mathcal{G}, c)) \leq \text{size}(\mathcal{F})$ .*

Let  $\mathcal{G}'$  be another irreducible presentation of  $X$  with a  $p$ -coloring  $c'$  of its states. Up to a conjugacy,  $\mathcal{F}(\mathcal{G}, c)$  and  $\mathcal{F}(\mathcal{G}', c')$  are equal.

*Proof.* We first prove that, up to a conjugacy of  $\mathcal{F}$ , we have  $F_{\mathcal{G}}(\mathcal{V}_i) \cap \mathcal{F}_i = \emptyset$ . Let us assume that this is false. For any  $j$  such that  $0 \leq j \leq p-1$ , there exists an integer  $i_j$ , with  $0 \leq i_j \leq p-1$ , such that there is a word  $w_j \in F_{\mathcal{G}}(\mathcal{V}_{i_j}) \cap \mathcal{F}_{(i_j+j \bmod p)}$ . That is, the word  $w_j$  is the label of a path  $\pi_j$  starting at some state in  $F_{\mathcal{G}}(\mathcal{V}_{i_j})$  with  $w_j \in \mathcal{F}_{(i_j+j \bmod p)}$ . Since  $\mathcal{G}$  is irreducible, one can choose a walk with label  $x$  that Moreover, since  $\mathcal{G}$  has a  $p$ -coloring and  $w_j \in F_{\mathcal{G}}(\mathcal{V}_{i_j})$ , one

can choose the path such that  $w_j \prec_{i_j} u$  for all integers  $j$ . Since  $X = X_{\mathcal{F}}$ , there is an integer  $k$  such that, for any integer  $l$ ,  $w \prec_l x \Rightarrow w \notin \mathcal{F}_{(k+l \bmod p)}$ . By taking  $l = i_k$ , we get that  $w_k \not\prec_{i_k} x$ , which is a contradiction.

Next, we change  $\mathcal{F}$  into another list  $\mathcal{E}$  such that each proper prefix of a word in  $\mathcal{E}_i$  belongs to  $F_{\mathcal{G}}(\mathcal{V}_i)$ . For this, one replaces each word in  $\mathcal{F}_i$  by its shortest prefix which is not in  $F_{\mathcal{G}}(\mathcal{V}_i)$ . Thus we define  $\mathcal{E}$  by the formula

$$\mathcal{E}_i = (F_{\mathcal{G}}(\mathcal{V}_i)\Sigma) \cap (\Sigma^* - F_{\mathcal{G}}(\mathcal{V}_i)) \cap (\mathcal{F}_i(\Sigma^*)^{-1}).$$

Note that the new list  $\mathcal{E}$  is still a regular periodic forbidden list of  $X$  for the period  $p$ . Indeed, it is clear that  $X_{\mathcal{E}} \subset X$ . Conversely, let  $x \in X$ . Up to some shift, the word  $x$  is the label of a path in  $\mathcal{G}$  going through a state of  $\mathcal{V}_j$  before reading the block  $x_{[j,k]}$  for any  $k \geq j$ . Hence  $x_{[j,k]} \in F_{\mathcal{G}}(\mathcal{V}_j)$  and thus  $x_{[j,k]} \notin \mathcal{E}_j$ . Thus,  $X = X_{\mathcal{E}}$ .

Now, we remove each word  $w \in \mathcal{E}_i$  which is not in  $\mathcal{F}(\mathcal{G}, c)_i$  and add at most one word shorter than  $w$  into some  $\mathcal{E}_j$  in order to still have a periodic forbidden list of  $X$ . If  $w \notin \mathcal{F}(\mathcal{G}, c)_i$ , there are indices  $j, j'$  such that  $w_{[j,j']} \in \mathcal{F}(\mathcal{G}, c)_{i+j \bmod p}$ . We add  $w_{[j,j]} \in \mathcal{E}_j$  and remove  $w$  from  $\mathcal{E}_i$ . It is important to note that  $j, j'$  are unique in this case. Indeed, let us assume that there are two factors  $v_1$  and  $v_2$  of  $w$ , both shorter than  $w$ , with  $v_1 = w_{[j,j']}$  in  $\mathcal{F}(\mathcal{G}, c)_{i+j \bmod p}$  and  $v_2 = w_{[k,k']}$  in  $\mathcal{F}(\mathcal{G}, c)_{i+k \bmod p}$ . Since  $w_{[0,|w|-2]} \in F_{\mathcal{G}}(\mathcal{V}_i)$ ,  $j' = k' = |w| - 1$  and  $v_1$  is a suffix of  $v_2$ , or vice-versa. This contradicts the

fact that  $\mathcal{F}(\mathcal{G}, c)$  is periodic anti-factorial. Hence at most one word is added whenever one is removed.

The new list  $\mathcal{D}$  satisfies  $\mathcal{D}_i \subseteq \mathcal{F}(\mathcal{G}, c)_i$ . We now show that  $\mathcal{D}_i = \mathcal{F}(\mathcal{G}, c)_i$ . Assume the contrary and let  $w$  be a word in  $\mathcal{F}(\mathcal{G}, c)_i - \mathcal{D}_i$ . If  $w = ua = bv$  with  $a, b \in \Sigma$ , we have  $u \in F_{\mathcal{G}}(\mathcal{V}_i)$ ,  $ua \notin F_{\mathcal{G}}(\mathcal{V}_i)$ , and  $v \in F_{\mathcal{G}}(\mathcal{V}_{i+1})$ . Hence  $u$  is the label of a path in  $\mathcal{G}$  starting at a state  $I \in \mathcal{V}_i$  and  $v$  is the label of a path ending in a state  $J \in \mathcal{V}_{i+|w| \bmod p}$ . For any left-infinite word  $z$  labeling a path ending at  $I$ , and any right-infinite word  $y$  labeling a path starting at  $J$ , the word  $zwy$  is in  $X_{\mathcal{D}}$ . It is possible to choose  $z$  and  $y$  such that  $zwy \notin X_{\mathcal{F}(\mathcal{G}, c)}$ , which contradicts the fact  $X = X_{\mathcal{D}}$ . Hence  $\mathcal{D} = \mathcal{F}(\mathcal{G}, c)$ . By construction, if  $\mathcal{F}$  is finite, then  $\mathcal{D}$  is also, and  $\text{size}(\mathcal{D}) \leq \text{size}(\mathcal{E}) \leq \text{size}(\mathcal{F})$ . Thus  $\text{size}(\mathcal{F}(\mathcal{G}, c)) \leq \text{size}(\mathcal{F})$ .

We now prove the second statement of the proposition. We first transform  $\mathcal{F}(\mathcal{G}', c')$  into  $\mathcal{F}'$  as above. The size of  $\mathcal{F}'$  is less than the size of  $\mathcal{F}(\mathcal{G}', c')$  if  $\mathcal{F}' \neq \mathcal{F}(\mathcal{G}', c')$ . We then transform  $\mathcal{F}'$  into  $\mathcal{D} = \mathcal{F}(\mathcal{G}, c)$ . Again, the size of  $\mathcal{D}$  is less than the size of  $\mathcal{F}'$  if  $\mathcal{D} \neq \mathcal{F}'$ . It follows that  $\text{size}(\mathcal{F}(\mathcal{G}, c)) \leq \text{size}(\mathcal{F}(\mathcal{G}', c'))$  and the two sets are equal whenever the sizes are equal. By reversing the roles played by  $\text{size}(\mathcal{F}(\mathcal{G}, c))$  and  $\text{size}(\mathcal{F}(\mathcal{G}', c'))$ , we conclude that equality holds and that the two lists are equal, up to some conjugacy. ■

For an irreducible sofic shift  $X$ , we denote by  $\mathcal{SO}(X)$  the list  $\mathcal{F}(\mathcal{G}, c)$  where  $\mathcal{G}$  is the Shannon cover of  $X$ ,  $p$  is the period of  $\mathcal{G}$ , and  $c$  is a  $p$ -coloring of the states of  $\mathcal{G}$ . It is defined up to a conjugacy of the list. Although the words in this periodic forbidden list were called the periodic first offenders of  $X$  in [14], [15], the discussion above prompts us to more appropriately call them the *Shannon periodic first offenders* of  $X$ .

**Example 10** The Shannon cover of the interleaved-biphase shift, Fig. 8, has period 4. The Shannon periodic first offenders are

$$\begin{aligned} \mathcal{O}_0 &= \{000, 010, 101, 111\}, \\ \mathcal{O}_1 &= \{000, 010, 101, 111\}, \\ \mathcal{O}_2 &= \emptyset, \\ \mathcal{O}_3 &= \emptyset. \end{aligned}$$

■

The following corollary, which is a direct consequence of Proposition 13, provides an alternative way to check whether an irreducible sofic shift is PFT, based upon the size of the list of Shannon periodic first offenders.

**Corollary 14.** *Let  $X$  be an irreducible sofic shift. Then the following assertions are equivalent.*

- $X$  is PFT.
- $\mathcal{SO}(X)$  is finite.

■

It was conjectured in [14], [15] that the size of  $\mathcal{MF}(X)$  is the minimal size of any periodic forbidden list of  $X$  for any period. The following example shows that this is not true. Thus, the minimality of the Shannon periodic first offenders is in general limited to periodic forbidden lists for the period of the Shannon cover.

**Example 11** Let  $X$  be the shift on the alphabet  $\Sigma = \{a, b, c, d, e\}$  presented by the Shannon cover of Fig. 11. The shift  $X$  is FT and its minimal periodic forbidden list for the period  $p = 1$ , i.e., its list of first offenders, is  $\mathcal{F} = \{c, d, e, aa, bb\}$ . For the period  $p = 2$ , which is the period of the Shannon cover,  $\mathcal{SO}(X) = \mathcal{E}$  where  $\mathcal{E}_0 = \{c, d, e, b\}, \mathcal{E}_1 = \{c, d, e, a\}$ . Hence  $\text{size}(\mathcal{SO}(X)) > \text{size}(\mathcal{F})$ . ■

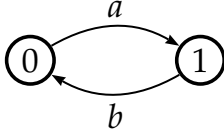

Fig. 11. A shift of finite type  $X$  over the alphabet  $\Sigma = \{a, b, c, d, e\}$ . We have  $X = X_{\mathcal{F}}$  with  $\mathcal{F} = \{c, d, e, aa, bb\}$  for the period  $p = 1$ . We also have  $X = X_{\mathcal{E}}$  with  $\mathcal{E}_0 = \{b, c, d, e\}, \mathcal{E}_1 = \{a, c, d, e\}$  for the period  $p = 2$ . The size of  $\mathcal{F}$  is less than the size of  $\mathcal{E}$  and the period of the Shannon cover of  $X$  is 2.

Let  $X$  be an irreducible PFT shift and  $p$  the period of its Shannon cover  $\mathcal{G}$ . When  $d$  divides  $p$ , we denote by  $\mathcal{SO}(X, d)$  the list  $\mathcal{F}(\mathcal{G}, c)$  where  $c$  is a  $d$ -coloring of  $\mathcal{G}$ . The example above suggests the following proposition.

**Proposition 15.** *Let  $X$  be an irreducible PFT shift and  $p$  the period of its Shannon cover. We have*

$$\min_{d/p} \text{size}(\mathcal{SO}(X, d)) \leq \min_{\mathcal{F}|X=X_{\mathcal{F}}} \text{size}(\mathcal{F}).$$

*Proof.* Note that the numbers involved in the inequality are finite whenever  $X$  is PFT.

Let  $\mathcal{F}$  be a finite periodic forbidden list of an irreducible PFT shift  $X$  for a period  $T$ . By Lemma 5, one can assume, without loss of generality, that  $\mathcal{F}$  is a finite periodic forbidden list of  $X$  for the period  $d = \gcd(p, T)$  (the size of  $\mathcal{F}$  is unchanged). By Proposition 13,  $\text{size}(\mathcal{F}) \geq \text{size}(\mathcal{SO}(X, d))$ , which completes the proof. ■

## VI. CAPACITY OF PFT SHIFTS

The *base-2 capacity*, or simply *capacity* of a sofic shift space  $X$  over an alphabet  $\Sigma$  is defined as

$$C(X) = \lim_{n \rightarrow \infty} \frac{1}{n} \log_2 |\mathcal{B}_n(X)|.$$

It measures the growth rate of the number of words of length  $n$  in  $X$ . It is well known that the capacity of a sofic shift is the logarithm of the largest real eigenvalue of the adjacency matrix of a lossless presentation [16], [17].

In this section, we discuss methods for computing the capacity of a PFT shift from its periodic forbidden list. In Section VI-A, we review techniques for generating lossless (in fact, deterministic) presentations of a PFT shift described by a finite list of periodically forbidden words. Several of the techniques draw on the connections between symbolic dynamics and automata theory.

the nevertheless

In Section VI-B, we present a combinatorial technique for computing the capacity directly from a periodic forbidden list. It extends to PFT shifts the computation of the capacity of FT shifts presented by Pimentel and Uchôa-Filho in [21], relying on the well-known *Inclusion-Exclusion Principle* from enumerative combinatorics [19], [20]. It is also known as the *Goulden-Jackson Cluster Method* [31,32], [33, III.7.4] (see also [34]). This combinatorial method provides a much more efficient means to compute the capacity than the conventional graph-based method when the lengths of the periodically forbidden words are large compared to the number of words.

### A. Graph Construction

Suppose one is given a finite, anti-factorial list  $\mathcal{F}$  of forbidden words over an alphabet  $\Sigma$ . One can construct in a straightforward manner a presentation of the corresponding shift of finite type  $X_{\mathcal{F}}^{\Sigma}$  with  $|\Sigma|^{\ell_{\max}-1}$  states, where  $\ell_{\max}$  is the length of the longest word in  $\mathcal{F}$ . Of course, this construction has time complexity that is exponential in  $\text{size}(\mathcal{F})$ .

An alternative algorithm was described in the unpublished masters thesis of Sindhushayana [35]. The construction makes use of the close connections between symbolic dynamics and automata theory, a theme that underlies several of the other techniques we will mention. Although generally more practical than the straightforward approach, it is not computationally efficient in the sense of guaranteed time complexity polynomial in  $\text{size}(\mathcal{F})$ . A similar construction appeared in the unpublished doctoral dissertation of McEwen [36]. In [24], Crochemore *et al.* gave an efficient, automata-theoretic construction of a deterministic presentation that requires time only linear in  $\text{size}(\mathcal{F})$ .

These algorithms for FT shifts can be extended, often naturally, to PFT shifts. McEwen [36] includes such an extension, and [15] described a generalization of the procedure in [35]. Although neither of these run in polynomial time, for many applications they are convenient to implement and give insights into the properties of the PFT shift.

Constrained systems with unconstrained positions, introduced by Wjngaarden and Immink [10] and further studied by de Souza *et al.* [11], represent a natural example of PFT shift spaces. Given a sofic shift  $X$ , a positive integer  $T$ , and a subset  $U$  of integers modulo  $T$ , the authors of [11] construct a presentation of the unique maximal subsystem such that any position modulo  $T$  in  $U$  is unconstrained. Beginning with a finite-state presentation of the underlying shift  $X$ , their algorithm in general has exponential time and space complexity. However, for FT shifts, under a certain *gap condition* that restricts  $|U|$  relative to the memory of the shift, their algorithm is efficient, requiring only quadratic complexity in space and time. They also provide an efficient construction for Maximum-Transition-Run (MTR) constraints with parameter  $j \geq 1$  [8], the systems in which the maximum allowable length of a run of consecutive 1's is  $j$ .

Béal *et al.* [13] also recognized the connection between PFT shifts and constraints with unconstrained systems. Their construction of a presentation for such a system consists of two steps. First, they derive a periodic list of forbidden words that

define a maximal subsystem for  $T$  and  $U$ , given a prefix-free list  $\mathcal{F}$  of forbidden words defining the underlying FT shift. The description of  $\mathcal{F}$  must be in the form of a tree-like deterministic automaton called a *trie* [13]. (A linear time and space algorithm for this step has recently been given in [30].)

In the second step, they invoke a general procedure for constructing a finite-state presentation of a PFT shift defined by a periodic forbidden list. The input to the algorithm is a collection of  $T$  tries representing the periodically forbidden words associated with the phases  $0, 1, \dots, T-1$ . They show that this step has time and space complexity that is linear in the size of the periodic forbidden list.

In the remainder of this section, we briefly describe the construction algorithm presented in [15]. Although, strictly speaking, it is not efficient, it has proven to be useful in practice in the study of PFT constraints for data storage applications.

We first construct a non-deterministic finite automaton that accepts the complement of the language in which we are interested. An automaton accepting the language is formed by following a constructive proof that the class of regular languages is closed under complementation; see, e.g., [22, Theorem 3.2]. By deleting the non-accepting states of the resulting automaton, we obtain a graph representing the shift space. A detailed description of the construction follows.

Fix a pair  $\{\mathcal{F}, T\}$ . For  $i = 0, 1, 2, \dots, T-1$ , define the language

$$L_i \stackrel{\text{def}}{=} \{v \mid \text{setting } v = v_n v_{n+1} \cdots v_{n+|v|-1}, \\ \forall m, p \in [n, n+|v|-1], \text{ with } m \leq p, \text{ and all } w \in \mathcal{F}_i, \\ \text{if } m \bmod T = i \text{ then } v_{[m,p]} \neq w\},$$

as well as its complement,

$$L_i^c = \{v \mid \text{setting } v = v_n v_{n+1} \cdots v_{n+|v|-1}, \\ \exists m, p \in [n, n+|v|-1], \text{ with } m \leq p, \text{ and } w \in \mathcal{F}_i, \\ \text{such that } m \bmod T = i \text{ and } v_{[m,p]} = w\}.$$

Note that  $\mathcal{B}(X_{\{\mathcal{F}, T\}}) \subseteq \bigcup_{i=0}^{T-1} L_i$ .

Construct a non-deterministic graph  $\mathcal{G}_{nd}$  as follows. Fix  $T$  states labeled  $I_0, I_1, \dots, I_{T-1}$ . Draw an edge for each  $a \in \Sigma$  and each  $i \in [0, T-1]$  from  $I_i$  to  $I_{(i+1) \bmod T}$  with label  $a$ . Fix a state labeled  $K$ , and draw an edge (cycle) from  $K$  to  $K$  with label  $a$  for each  $a \in \Sigma$ . Now draw a path from  $I_i$  to  $K$  for each word  $w = w_0 w_1 \cdots w_{|w|-1}$  in  $\mathcal{F}$  with phase  $i$ .

Note that we may reduce the number of states in  $\mathcal{G}_{nd}$  by sharing common suffixes of forbidden words. From this observation, we have a simple relation for the number of states in  $\mathcal{G}_{nd}$  when suffixes are shared,

$$|\mathcal{V}(\mathcal{G}_{nd})| = T + 1 + \\ (\sum \text{lengths of distinct suffixes of words in } \mathcal{F}).$$

Put  $M_{nd,i} = (\mathcal{G}_{nd}, \Sigma, I_i, K)$ . It is straightforward to show that  $L(M_{nd,i}) = L_i^c$ . Indeed, a word in  $L_i^c$  is of the form  $u w v$ , where  $u$  and  $v$  are elements of  $\Sigma^*$ ,  $w \in \mathcal{F}_n$ , and  $(i + |u|) \bmod T = n$ . These are precisely the words accepted by  $M_{nd,i}$ .

Following the constructive proof in [22, Theorem 3.2], we

will build a deterministic automaton that accepts  $L(M_{nd,i})^c = L_i$ . First, construct a deterministic graph  $\mathcal{G}_d$  from  $\mathcal{G}_{nd}$  via the well-known *subset construction algorithm*, e.g., [16, Theorem 3.3.2], as follows. The state set,  $\mathcal{V}(\mathcal{G}_d)$ , is the set of all nonempty subsets of  $\mathcal{V}(\mathcal{G}_{nd})$ . For every edge  $e$  in  $E(\mathcal{G}_{nd})$  from  $i(e)$  to  $t(e)$  put edges in  $E(\mathcal{G}_d)$  with labels  $\mathcal{L}(e)$  from each  $I \in \mathcal{V}(\mathcal{G}_{nd})$  to each  $J \in \mathcal{V}(\mathcal{G}_{nd})$  such that  $i(e) \in I$  and  $t(e) \in J$ .

Put  $M'_i = (\mathcal{G}_d, \Sigma, I_i, F)$ , where  $F$  is the subset of  $\mathcal{V}(\mathcal{G}_d)$  consisting of those states that contain the accepting state of  $M_{nd,i}$ , i.e.,  $K$ . The automaton  $M'_i$  is deterministic and one can show that  $L(M'_i) = L(M_{nd,i})$ , e.g., [22, Theorem 2.1]. (We remark that this subset construction has, in generally, complexity that is exponential in the size of the initial presentation.)

Let  $M_i = (\mathcal{G}_d, \Sigma, I_i, \mathcal{V}(\mathcal{G}_d) - F)$ , i.e., the automaton constructed from  $M'_i$  by switching the roles of the accepting and non-accepting states. Since  $\mathcal{G}_d$  is deterministic,  $M_i$  accepts a word  $w$  if and only if  $w$  is in  $L^c(M'_i)$ , therefore  $L(M_i) = L^c(M'_i) = L_i$ . Note that the underlying labeled graph  $\mathcal{G}_d$  and the set of accepting states  $\mathcal{V}(\mathcal{G}_d) - F$  are the same for each  $i \in [0, \dots, T-1]$ , i.e., for each automaton  $M_i$ .

No accepting state of  $M_i$  may be reached from a non-accepting state. Hence we can delete the non-accepting states from  $\mathcal{G}_d$  without changing the language accepted by  $M_i$ . Let  $\mathcal{G}$  denote the graph that results from deleting the non-accepting states from  $\mathcal{G}_d$ . The construction may be simplified by keeping in mind that all accepting states will be deleted from  $\mathcal{G}_d$ , hence there is no need to distinguish between different accepting states nor to draw edges between different accepting states when constructing the deterministic automaton. In addition, only the subgraph of  $\mathcal{G}_d$  which may be reached from the starting states needs to be considered.

Finally, take the essential subgraph of  $\mathcal{G}$  and apply a state-minimization algorithm, e.g., [16, pp. 92]. If the shift is irreducible, this will result in the Shannon cover.

In Table I, we summarize the construction procedure, including the simplifications mentioned above.

TABLE I  
SUMMARY OF GRAPH CONSTRUCTION

- 1) Construct the non-deterministic graph  $\mathcal{G}_{nd}$  as described.
- 2) Construct a deterministic graph  $\mathcal{G}_d$  using the subset construction algorithm including only those states which may be reached from one of the starting states, and directing any edge which terminates in an accepting state into a single accepting state.
- 3) Construct  $\mathcal{G}$  by deleting the accepting state and all edges which begin or terminate there.
- 4) Take the essential subgraph of  $\mathcal{G}$ , and apply a state-minimization algorithm.

The following proposition establishes that  $X_{\mathcal{G}} = X_{\{\mathcal{F}, T\}}$ .

**Theorem 16.** *Choose  $\{\mathcal{F}, T\}$ . Let  $\mathcal{G}$  be the graph constructed following the method described above. Then  $X_{\{\mathcal{F}, T\}} = X_{\mathcal{G}}$ .*

*Proof.* Choose  $x \in X_{\mathcal{G}}$ . Since  $|\mathcal{V}(\mathcal{G})|$  is finite and every state in  $\mathcal{G}$  is reachable from some  $I_i$ , choose a starting state  $I_i$  such that any sub-word of  $x$  lies on a path originating from  $I_i$ . Let  $\pi$

be a path starting at  $I_i$  and terminating at  $i(\mathcal{L}^{-1}(x_0))$ . Put  $k = -(|\pi| + i)$ . Then for all  $m$  and all  $w \in \mathcal{F}_n$ , if  $m \bmod T = n$  then  $\sigma^k(x)_{[m, m+|w|-1]} \neq w$ . Therefore  $\sigma^k(x) \in X_{\{\mathcal{F}, T\}}$  and  $X_{\mathcal{G}} \subseteq X_{\{\mathcal{F}, T\}}$ .

For the reverse inclusion, choose  $w \in \mathcal{B}(X_{\{\mathcal{F}, T\}})$ . Then there exists  $i$  such that  $w \in L_i$ . In addition,  $w$  is left-extendable by words in  $\mathcal{B}(X_{\{\mathcal{F}, T\}})$ . Hence we can choose  $uw \in \mathcal{B}(X_{\{\mathcal{F}, T\}})$  such that  $uw \in \bigcup_{i=0}^{T-1} L_i$  and  $w \in \mathcal{B}(X_{\mathcal{G}})$ , i.e., we can choose some  $u$  such that  $w$  lies on the essential subgraph of  $\mathcal{G}$ . Therefore  $\mathcal{B}(X_{\{\mathcal{F}, T\}}) \subseteq \mathcal{B}(X_{\mathcal{G}})$  and  $X_{\{\mathcal{F}, T\}} \subseteq X_{\mathcal{G}}$ . ■

**Example 12** Consider the PFT(2) shift space over the binary alphabet  $\{0, 1\}$  with  $\mathcal{F}_0 = \{101\}$  and  $\mathcal{F}_1 = \{010\}$ . Applying the graph construction described above produces the non-deterministic graph  $\mathcal{G}_{nd}$  shown in Fig. 12, the deterministic graph  $\mathcal{G}_d$  shown in Fig. 13, and finally the Shannon cover  $\mathcal{G}$  shown in Fig. 14,

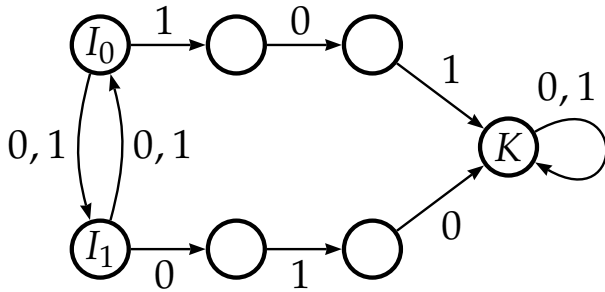

Fig. 12. Graph  $\mathcal{G}_{nd}$  corresponding to  $\Sigma = \{0, 1\}$ ,  $T = 2$ ,  $\mathcal{F}_0 = \{101\}$ ,  $\mathcal{F}_1 = \{010\}$ .

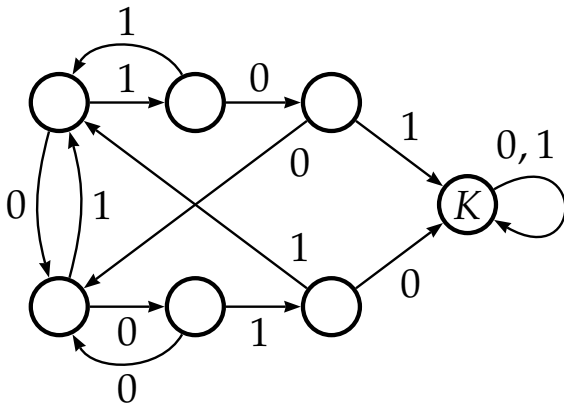

Fig. 13. Graph  $\mathcal{G}_d$  corresponding to  $\Sigma = \{0, 1\}$ ,  $T = 2$ ,  $\mathcal{F}_0 = \{101\}$ ,  $\mathcal{F}_1 = \{010\}$ .

### B. Combinatorial Determination of Capacity

The method we describe here is a computation of the capacity directly from the periodic forbidden list. As mentioned

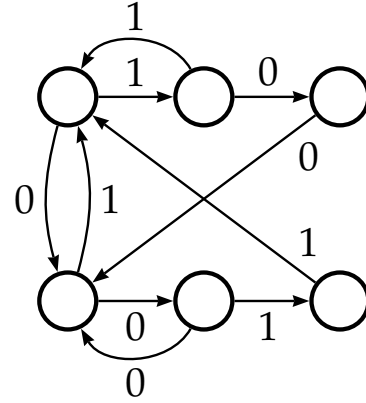

Fig. 14. Shannon cover corresponding to  $\Sigma = \{0, 1\}$ ,  $T = 2$ ,  $\mathcal{F}_0 = \{101\}$ ,  $\mathcal{F}_1 = \{010\}$ .

in the Introduction, it extends to periodic finite shifts the computation of the capacity of shifts of finite type presented by Pimentel and Uchôa-Filho in [21], based upon the combinatorial Inclusion-Exclusion Principle [19], [20], also known as the *Goulden-Jackson Cluster Method* [31], [32], [33, III.7.4], [34]).

Let us assume that  $X = X_{\mathcal{F}}$ , where  $\mathcal{F}$  is some finite anti-factorial periodic forbidden list for a period  $T$ . (Note that if the given list is not anti-factorial, it can be changed into one that is in linear time [13].) Denoting  $\mathcal{B}_n(X)$  by  $x_n$  for convenience, we define the generating series counting the number of factors of  $X$ :

$$C(z) = \sum_{n \geq 0} x_n z^n. \quad (1)$$

It is known (see for instance [37]) that  $C(z)$  is a rational series and that  $C(X)$  is  $\log 1/\rho$ , where  $\rho$  is the radius of convergence of  $C(z)$ .

Recalling the definition of the set  $X_0$  in Section II, we denote by  $\mathcal{B}^{(i)}(X)$  (for  $0 \leq i < T$ ) the set of factors  $u$  of  $X$  such that  $u \prec_i x$ , for some  $x \in X_0$ .

We set  $x_n^{(i)} = |\mathcal{B}^{(i)}(X) \cap \Sigma^n|$ , and define the generating series of the integers  $\sum_{i=0}^{T-1} x_n^{(i)}$ :

$$D(z) = \sum_{n \geq 0} \sum_{i=0}^{T-1} x_n^{(i)} z^n. \quad (2)$$

For an irreducible PFT shift  $X$ , it is known that

$$C(X) = \lim_{n \rightarrow \infty} \frac{1}{n} \log \sum_{i=0}^{T-1} x_n^{(i)}. \quad (3)$$

and  $C(X)$  is  $\log 1/\rho$ , where  $\rho$  is the radius of convergence of  $D(z)$ .

Let  $0 \leq i < T$  and let  $k \geq 0$ . If  $u \in \Sigma^*$ , we denote by  $n(u, i)$  the number of occurrences of a factor  $v$  of  $u$  such that  $v \prec_{i+j} u$  and  $v \in \mathcal{F}_{j \bmod T}$ . We denote by  $d(u, i, k)$  the number of ways to choose  $k$  indices  $j$  such that there is a factor  $v$  of  $u$  with  $v \prec_{i+j} u$  and  $v \in \mathcal{F}_{j \bmod T}$ . Note that  $d(u, i, k) =$

$\binom{n(u,i)}{k}$ ). Finally we define

$$\Delta(n, i, k) = \sum_{u:|u|=n} d(u, i, k).$$

By the Inclusion-Exclusion Principle, each word  $u$  of length  $n$  contributes 0 to  $\sum_{u:|u|=n} d(u, i, k)$  if it contains at least one word  $v \prec_{i+j} u$ , where  $v \in \mathcal{F}_{j \bmod T}$ . It contributes 1 otherwise, *i.e.* when it belongs to  $\mathcal{B}^{(i)}(X)$ . We deduce that

$$x_n^{(i)} = \sum_{k \geq 0} (-1)^k d(n, i, k). \quad (4)$$

We define the following bivariate generating series:

$$D(z, y, i) = \sum_{n \geq 0} \sum_{k \geq 0} \Delta(n, i, k) z^n y^k, \quad (5)$$

$$D(z, y) = \sum_{i=0}^{T-1} D(z, y, i). \quad (6)$$

It follows from Equations (2), (4), and (6) that

$$D(z) = D(z, -1).$$

**Example 13** We consider the PFT shift  $X = X_{\mathcal{F}}$  over the alphabet  $\Sigma = \{0, 1\}$  for a period  $T = 4$  with

$$\begin{aligned} \mathcal{F}_0 &= \{111\}, \\ \mathcal{F}_1 &= \{111\}, \\ \mathcal{F}_2 &= \{1111\}, \\ \mathcal{F}_3 &= \emptyset. \end{aligned}$$

This list of periodically forbidden words defines the TMTR(2,2,3,3) constraint. This constraint can be described as follows. The number of consecutive 1's ending at the time indices  $0 \bmod 4$  and  $1 \bmod 4$  is at most 2, while the number of consecutive 1's ending at the time indices  $2 \bmod 4$  and  $3 \bmod 4$  is at most 3. It is not difficult to see that this description is equivalent to saying that the block 111 is forbidden when it begins at the time indices  $2 \bmod 4$  and  $3 \bmod 4$ , and the block 1111 is forbidden when it begins at the time indices  $0 \bmod 4$ . Hence the TMTR(2,2,3,3) constraint is described by the shift  $X_{\mathcal{F}}$ .

Let  $u = 000011111100$ . It has the word 111 of  $\mathcal{F}_0$  as a factor at position 4, the word 111 of  $\mathcal{F}_1$  as a factor at position 5, and the word 1111 of  $\mathcal{F}_2$  as a factor at position 6. Hence it contributes 1 to  $d(12, 0, 0)$ , 3 to  $d(12, 0, 1)$ ,  $\binom{3}{2}$  to  $d(12, 0, 2)$ , 1 to  $d(12, 0, 3)$ , and 0 to  $d(12, 0, k)$  for  $k > 3$ . Its total contribution to  $\sum_{k \geq 0} (-1)^k d(n, 0, k)$  is  $1 - \binom{3}{1} + \binom{3}{2} - 1 = 0$ .

Now let  $u = 000000000000$ . It contributes 1 to the sum  $\sum_{k \geq 0} (-1)^k d(n, 0, k)$  since it contributes 1 to  $d(12, 0, 0)$  and 0 to  $d(12, 0, k)$  for  $k > 0$ .

We now describe how to compute the bivariate series  $D(z, y)$ . Let  $\mathcal{F} = (\mathcal{F}_0, \dots, \mathcal{F}_{T-1})$  be a finite periodic forbidden list. If  $\mathcal{F}_i$  is a nonempty set, we define the set  $\tilde{F}_i = \{(f, i) \mid f \in \mathcal{F}_i\}$ . If  $\mathcal{F}_i$  is the empty set we denote by  $\tilde{F}_i$  the singleton containing the integer  $i$ . We denote by  $\tilde{F}$  the union of the  $\tilde{F}_i$ . Note that the size of  $\tilde{F}$  is at most  $\text{size}(\mathcal{F}) + T - 1$ .

Let  $(x, i), (y, j)$  be two pairs of a word and an integer modulus  $T$ . We denote by  $(x, i) \otimes (y, j)$  the set of pairs  $(uvw, i)$

such that  $x = uv, y = vw$ , with  $u \neq \varepsilon, u \neq x$ , and  $v \prec_{j-i \bmod T} x$  (see Fig. 15).

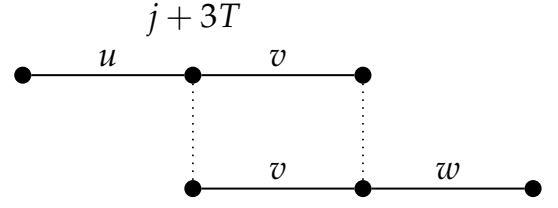

Fig. 15. An example of a factorization of  $x = uv$  and  $y = vw$ . The pair  $(uvw, i)$  belongs to  $(x, i) \otimes (y, j)$ .

We define a square matrix  $G(z)$  with entries indexed by  $\tilde{F} \times \tilde{F}$  as follows. For any  $(f, i), (g, j), k, r$  in  $\tilde{F}$ ,

$$G(z)_{(f,i)(g,j)} = \sum_{\substack{(uvw,i) \in (f,i) \otimes (g,j) \\ f=uv, g=vu}} z^{|u|},$$

$$G(z)_{k(f,i)} = G(z)_{(f,i)k} = G(z)_{kr} = 0.$$

**Example 13 (continued).** The matrix  $G(z)$  for the periodic forbidden list  $\mathcal{F}$  of period 4 of Example 13 is the following  $|\tilde{F}| \times |\tilde{F}|$  matrix with  $\tilde{F} = \{(111, 0), (111, 1), (1111, 2), 3\}$ .

$$G(z) = \begin{bmatrix} 0 & z & z^2 & 0 \\ 0 & 0 & z & 0 \\ z^2 & z^3 & 0 & 0 \\ 0 & 0 & 0 & 0 \end{bmatrix}.$$

If  $P, Q$  are sets of pairs  $(x, i)$ , where  $x$  is a word and  $0 \leq i < T$ , we denote by  $P \otimes Q$  the set

$$P \otimes Q = \bigcup_{\substack{(x,i) \in P \\ (y,j) \in Q}} (x, i) \otimes (y, j),$$

and by  $(x, i) \otimes Q$  the set  $\{(x, i) \otimes (y, j) \mid (y, j) \in Q\}$ . Note that  $((x, i) \otimes (y, j)) \otimes (z, k) = (x, i) \otimes ((y, j) \otimes (z, k))$ , and that, for  $k > 0$ , the  $((f, i), (g, j))$ th entry of  $G(z)^k z^{|g|}$  is the number of sequences  $u$  beginning with  $f$ , ending with  $g$  such that  $(u, i)$  is a  $k$ -product in  $(f, i) \otimes \dots \otimes (g, j)$ .

We extend the construction of the sets of pairs  $(f, i) \otimes (g, j)$  to all possible  $\otimes$ -products among sequences in  $\mathcal{F}$ . Let

$$V = \cup_{r \geq 2} \{(f_1, i_1) \otimes (f_2, i_2) \otimes \dots \otimes (f_r, i_r) \mid (f_j, i_j) \in \tilde{F}\}.$$

For  $0 \leq i, j < T$ , we define the bivariate series

$$V_{i,j}(z, y) = \sum_{n \geq 0} \sum_{k \geq 0} v(n, k, i, j) z^n y^{k+1},$$

where  $v(n, k, i, j)$  is the number of words  $u$  of length  $n$  such that  $(u, i)$  is a  $k$ -fold  $\otimes$ -product  $(f_1, i_1) \otimes (f_2, i_2) \otimes \dots \otimes (f_k, i_k)$  with  $i_1 = i$  and  $i_k + |f_k| = j$ . Hence each word  $u$  counted in the above sum has a decomposition into  $(k+1)$ -overlapping words in  $\mathcal{F}$  (see Fig. 16).

We define the  $T \times T$ -matrix  $V(z, y)$

$$V(z, y) = (V_{i,j}(z, y))_{0 \leq i, j < T}.$$

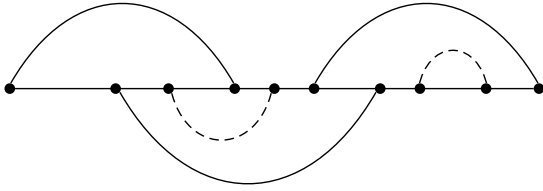

Fig. 16. An example of a 3-overlapping. Note that overlappings like the ones drawn in dashed lines are not allowed since the periodic list is anti-factorial.

We then define the  $|\tilde{F}| \times T$  matrix  $\Phi(z)$  as follows: For any  $(f, i)$ ,  $k$  in  $I$ ,  $0 \leq j < T$ ,

$$\Phi(z)_{(f,i)j} = \begin{cases} z^{|f|} & \text{if } j = i + |f| \pmod{T}, \\ 0 & \text{otherwise,} \end{cases}$$

$$\Phi(z)_{kj} = 0.$$

**Example 13 (continued).** The matrix  $\Phi(z)$  for the periodic forbidden list  $\mathcal{F}$  for period 4 in Example 13 is an  $|\tilde{F}| \times T$  matrix with  $\tilde{F} = \{(111, 0), (111, 1), (1111, 2), 3\}$ .

$$\Phi(z) = \begin{bmatrix} 0 & 0 & 0 & z^3 \\ z^3 & 0 & 0 & 0 \\ 0 & 0 & z^4 & 0 \\ 0 & 0 & 0 & 0 \end{bmatrix}.$$

We define a  $T \times |\tilde{F}|$ -matrix  $\Psi(z)$  as follows: For any  $(f, i)$ ,  $k$  in  $\tilde{F}$  and  $0 \leq j < T$ ,

$$\Psi(z)_{j(f,i)} = \begin{cases} 1 & \text{if } j = i, \\ 0 & \text{otherwise,} \end{cases}$$

$$\Psi(z)_{jk} = \begin{cases} 1 & \text{if } k = j, \\ 0 & \text{otherwise.} \end{cases}$$

**Example 13 (continued).** The matrix  $\Psi(z)$  for the periodic forbidden list  $\mathcal{F}$  for period 4 in Example 13 is an  $|\tilde{F}| \times T$  matrix with  $\tilde{F} = \{(111, 0), (111, 1), (1111, 2), 3\}$ .

$$\Psi(z) = \begin{bmatrix} 1 & 0 & 0 & 0 \\ 0 & 1 & 0 & 0 \\ 0 & 0 & 1 & 0 \\ 0 & 0 & 0 & 1 \end{bmatrix}.$$

Note that in this example  $\Phi(z)$  and  $\Psi(z)$  are square matrices since  $|\tilde{F}| = T$ .

Therefore, for  $0 \leq i, j < T$ , we get

$$\begin{aligned} V_{i,j}(z, y) &= \sum_{n \geq 0} \sum_{k \geq 0} v(n, k, i, j) z^n y^k, \\ &= \sum_{k \geq 0} \left( \sum_{n \geq 0} v(n, k, i, j) z^n \right) y^k, \\ &= \sum_{k \geq 0} \mathbf{1}_i^T \Psi(z) G(z)^k \Phi(z) \mathbf{1}_j y^k \end{aligned}$$

where  $\mathbf{1}_i$  is the column characteristic vector of  $i$ , and  $\mathbf{I}$  is the  $|\tilde{F}| \times |\tilde{F}|$  identity matrix.

Hence

$$\begin{aligned} V(z, y) &= \Psi(z) \sum_{k \geq 0} (G(z)^k y^k) \Phi(z) y, \\ &= \Psi(z) (\mathbf{I} - G(z)y)^{-1} \Phi(z) y. \end{aligned}$$

where  $\mathbf{I}$  is the  $|\tilde{F}| \times |\tilde{F}|$  identity matrix.

Finally, we define a  $T \times T$  square matrix  $P(z)$ . For any  $0 \leq i, j < T$ ,

$$P(z)_{ij} = \begin{cases} |\Sigma|z & \text{if } j = i + 1 \pmod{T}, \\ 0 & \text{otherwise.} \end{cases}$$

**Example 13 (continued).** The matrix  $P(z)$  for the periodic forbidden list  $\mathcal{F}$  of period 4 of Example 13 is an  $|\tilde{F}| \times |\tilde{F}|$  matrix with  $\tilde{F} = \{(111, 0), (111, 1), (1111, 2), 3\}$ .

$$P(z) = \begin{bmatrix} 0 & 2z & 0 & 0 \\ 0 & 0 & 2z & 0 \\ 0 & 0 & 0 & 2z \\ 2z & 0 & 0 & 0 \end{bmatrix}.$$

For  $0 \leq i, j < T$ , we denote by  $V_{ij}$  the set of pairs  $(u, i)$  of  $V$  which are  $\otimes$ -products of the form  $(f_1, i_1) \otimes (f_2, i_2) \otimes \dots \otimes (f_r, i_r)$  with  $i_1 = i$  and  $j = i + |u| \pmod{T}$  ( $= i_r + |f_r| \pmod{T}$ ).

Let  $\mathcal{P} = (\{0, 1, \dots, T-1\}, E)$  be a finite state cover with labels in  $\Sigma^*$  and an edge labeled by each letter of the alphabet  $\Sigma$  from the state  $i$  to the state  $i+1 \pmod{T}$ , and a path labeled by  $u$  from the state  $i$  to the state  $j$  for each word  $u$  such that  $(u, i) \in V_{ij}$ . The form of  $\mathcal{P}$  is illustrated in Fig. 17 for  $\Sigma = \{0, 1\}$ .

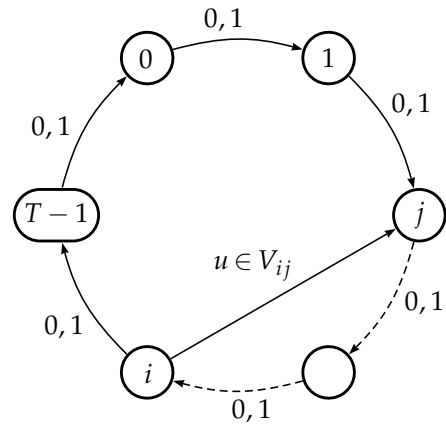

Fig. 17. The automaton  $\mathcal{P}$  for the period  $T$ .

It comes from [32] that the bivariate series  $D(z, y, i)$  enumerates the labels of paths in  $\mathcal{P}$  starting at state  $i$  for any  $0 \leq i < T$ . The bivariate series  $D(z, y)$  enumerates the labels of all paths in  $\mathcal{P}$ .

Hence

$$\begin{aligned} D(z, y) &= \mathbf{1}^T \sum_{r \geq 0} (P(z) + V(z, y))^r \mathbf{1} \\ &= \mathbf{1}^T (\mathbf{I} - P(z) - \Psi(z)(\mathbf{I} - G(z)y)^{-1} \Phi(z)y)^{-1} \mathbf{1}. \end{aligned}$$



We get

$$D(z) = \mathbf{1}^T(1 - P(z) + \Psi(z)(\mathbf{I} + G(z))^{-1}\Phi(z))^{-1}\mathbf{1}. \quad (7)$$

As a consequence,  $C(X)$  is  $\log 1/\rho$ , where  $\rho$  is the positive root of minimal modulus of

$$\det\left(\mathbf{I} - P(z) + \Psi(z)(\mathbf{I} + G(z))^{-1}\Phi(z)\right). \quad (8)$$

**Example 13** (*continued*). For the periodic forbidden list  $\mathcal{F}$  of period 4 of Example 13, the series  $D(z)$  is<sup>1</sup>

$$D(z) = \frac{1}{4z^8 - 13z^4 + 1} \left( 8z + 16z^2 + 30z^3 + 4z^4 + 2z^5 - 8z^6 - 12z^7 + z^8 - 2z^9 + z^{10} + 4 \right)$$

The capacity of  $X$  is  $\log 1/\rho$ , where  $\rho$  is the positive root of minimal modulus of

$$13z^4 - 4z^8 - 1 = (3z^2 + 2z^4 - 1)(3z^2 - 2z^4 + 1),$$

We get  $\rho = \sqrt{\frac{\sqrt{17}-3}{2}}$  and  $\lambda = 1/\rho = 1.887207676$ .

**Example 14** We consider the PFT shift  $X = X_{\mathcal{F}}$  over the alphabet  $\Sigma = \{0, 1\}$  for a period  $T = 2$  with

$$\begin{aligned} \mathcal{F}_0 &= \{111\}, \\ \mathcal{F}_1 &= \emptyset. \end{aligned}$$

The  $|\tilde{F}| \times |\tilde{F}|$  matrices  $G(z)$ ,  $\Phi(z)$  and  $P(z)$ , with  $\tilde{F} = \{(111, 0), 1\}$  are

$$G(z) = \begin{bmatrix} z^2 & 0 \\ 0 & 0 \end{bmatrix}, \quad \Phi(z) = \begin{bmatrix} 0 & z^3 \\ 0 & 0 \end{bmatrix}, \quad P(z) = \begin{bmatrix} 0 & 2z \\ 2z & 0 \end{bmatrix}.$$

The series  $D(z)$  is

$$D(z) = \frac{-4z - 2z^2 - 3z^3 - 2}{3z^2 + 2z^4 - 1}.$$

The capacity of  $X$  is  $\log 1/\rho$ , where  $\rho$  is the positive root of minimal modulus of  $3z^2 + 2z^4 - 1$ . We get  $\rho = \sqrt{\frac{\sqrt{17}-3}{2}}$ . This PFT shift has the same capacity as the PFT shift of Example 13. See [9] for a classification of the capacities of the TMTR( $\mathbf{m}$ ) constraints where  $\mathbf{m}$  is a positive integral vector up to a size four.

**Example 15** We consider the PFT shift  $X = X_{\mathcal{F}}$  over the alphabet  $\Sigma = \{0, 1\}$  for a period  $T = 2$  with

$$\begin{aligned} \mathcal{F}_0 &= \{101\}, \\ \mathcal{F}_1 &= \{010\}. \end{aligned}$$

The  $|\tilde{F}| \times |\tilde{F}|$  matrices  $G(z)$ ,  $\Phi(z)$  and  $P(z)$ , with  $\tilde{F} = \{(101, 0), (010, 1)\}$  are

$$G(z) = \begin{bmatrix} z^2 & z \\ z & z^2 \end{bmatrix}, \quad \Phi(z) = \begin{bmatrix} 0 & z^3 \\ z^3 & 0 \end{bmatrix}, \quad P(z) = \begin{bmatrix} 0 & 2z \\ 2z & 0 \end{bmatrix}.$$

The series  $D(z)$  is

$$D(z) = \frac{-2z - 2z^2 - 2}{z + z^2 + z^3 - 1}.$$

<sup>1</sup>obtained with a MuPAD computation.

The capacity of  $X$  is  $\log 1/\rho$ , where  $\rho$  is the positive root of minimal modulus of  $z + z^2 + z^3 - 1$ . This time-varying constraint has a capacity approximately 0.8791464216. This capacity is equal to the capacity of the MTR(2) constraint (see [38] for the relationship between these two constraints).

## VII. CONCLUSIONS

We have introduced the class of periodic-finite-type (PFT) shift spaces. This class of sofic shifts lie between the class of finite-type shifts and almost-finite-type shifts. We proved several properties of graph presentations of these spaces. For a given PFT space, we identified a particular list of periodically forbidden words, the periodic first-offenders, that enjoy certain minimality properties with respect to other forbidden lists defining the space. Finally, we consider the calculation of the capacity of a PFT shift. We present a straightforward algorithm to construct a graph presenting a PFT space that can be used to determine the capacity of the constraints. We also present a quite different method which relies upon techniques from enumerative combinatorics and that appears to be very effective when the size of the periodic forbidden blocks is large compared to the number of blocks in the list.

## REFERENCES

- [1] K. A. S. Immink, P. H. Siegel, and J. K. Wolf, "Codes for digital recorders," *IEEE Trans. Inf. Theory*, vol. 44, no. 6, pp. 2260–2299, Oct. 1998.
- [2] W. Bliss, "An 8/9 rate time-varying trellis code for high density magnetic recording," *IEEE Trans. Magn.*, vol. 33, no. 9, pp. 2746–2748, Sept. 1997.
- [3] K. K. Fitzpatrick and C. S. Modlin, "Time-varying MTR codes for high density magnetic recording," in *Proc. IEEE Global Telecommun. Conf.*, vol. 3, (Phoenix, AZ, USA), pp. 1250–1253, IEEE, Nov. 1997.
- [4] B. E. Moision, P. H. Siegel, and E. Soljanin, "Distance-enhancing codes for digital recording," *IEEE Trans. Magn.*, vol. 34, no. 1, pp. 69–74, Jan. 1998.
- [5] R. Karabed, P. H. Siegel, and E. Soljanin, "Constrained coding for binary channels with high intersymbol interference," *IEEE Trans. Inf. Theory*, vol. 45, no. 6, pp. 1777–1797, Sept. 1999.
- [6] R. Karabed and P. H. Siegel, "Coding for higher order partial response channels," in *Proc. SPIE* (M. R. Raghuveer, S. A. Dianat, S. W. McLaughlin, and M. Hassner, eds.), vol. 2605, (Philadelphia, PA, USA), pp. 92–102, Oct. 1995.
- [7] E. Soljanin, "On-track and off-track distance properties of class 4 partial response channels," in *Proc. SPIE* (M. R. Raghuveer, S. A. Dianat, S. W. McLaughlin, and M. Hassner, eds.), vol. 2605, (Philadelphia, PA, USA), pp. 92–102, Oct. 1995.
- [8] J. Moon and B. Brickner, "Maximum transition run codes for data storage systems," *IEEE Trans. Magn.*, vol. 32, pp. 3992–3994, Sept. 1996.
- [9] T. Lei Poo and B. H. Marcus, "Time-varying maximum transition run constraints," *IEEE Trans. Inf. Theory*, vol. 52, no. 10, pp. 4464–4480, Oct. 2006.
- [10] A. J. van Wijngaarden and K. A. S. Immink, "Maximum runlength-limited codes with error control capabilities," *IEEE J. Select. Areas Commun.*, vol. 19, no. 4, pp. 602–611, Apr. 2001.
- [11] J. C. de Souza, B. H. Marcus, R. New, and B. A. Wilson, "Constrained systems with unconstrained positions," *IEEE Trans. Inf. Theory*, vol. 48, no. 4, pp. 866–879, Apr. 2002.
- [12] T. Lei Poo, P. Chaichanavong, and B. H. Marcus, "Tradeoff functions for constrained systems with unconstrained positions," *IEEE Trans. Inf. Theory*, vol. 52, no. 4, pp. 1425–1449, Apr. 2006.
- [13] M.-P. Béal, M. Crochemore, G. Fici, "Presentations of constrained systems with unconstrained positions," *IEEE Trans. Inf. Theory*, vol. 51, no. 5, pp. 1891–1900, May 2005.
- [14] B. E. Moision and P. H. Siegel, "Periodic-finite-type shift spaces," in *Proc. IEEE Int. Symp. Inf. Theory*, Washington, DC, June 24–29, 2001, p. 65.

- [15] B. E. Moision and P. H. Siegel, "Periodic-finite-type shift spaces," preprint.
- [16] D. Lind and B. Marcus, *An Introduction to Symbolic Dynamics and Coding*. Cambridge, U.K.: Cambridge Univ. Press, 1995, reprinted in 1999.
- [17] B. H. Marcus, R. M. Roth, and P. H. Siegel, "Constrained systems and coding for recording channels," in *Handbook of Coding Theory* (V. S. Pless and W. C. Huffman, eds.), ch. 20, Elsevier Science, 1998.
- [18] Z. A. Khayrallah and D. L. Neuhoff, "Shift spaces encoders and decoders." preprint.
- [19] J. H. van Lint and R. M. Wilson, *A Course in Combinatorics*, Cambridge University Press, Cambridge, 1992.
- [20] L. J. Guibas and A. M. Odlyzko, "String overlaps, pattern matching, and nontransitive games," *J. Combin. Theory Ser. A*, vol. 30, pp. 183–208, 1981.
- [21] C. Pimentel and B. F. Uchôa-Filho, "A combinatorial approach to finding the capacity of the discrete noiseless channel," *IEEE Trans. Inf. Theory*, vol. 49, no. 8, pp. 2024–2028, Aug. 2003.
- [22] J. E. Hopcroft and L. D. Ullman, *Introduction to Automata Theory, Languages, and Computation*. Reading, MA: Addison-Wesley, 1979.
- [23] M.-P. Béal, F. Mignosi, A. Restivo, and M. Sciortino, "Forbidden words in symbolic dynamics," *Adv. in Appl. Math.*, vol. 25, pp. 163–193, 2000.
- [24] M. Crochemore, F. Mignosi, and A. Restivo, "Automata and forbidden words," *Information Processing Letters*, vol. 67, pp. 111–117, 1998.
- [25] M. Sciortino, *Automata, Forbidden Words and Applications to Symbolic Dynamics and Fragment Assembly*, Ph.D. thesis, University of Palermo, 2001.
- [26] R. Karabed and B. H. Marcus, "Sliding-block coding for input-restricted channels," *IEEE Trans. Inf. Theory*, vol. 34, no. 1, pp. 2–26, Jan. 1988.
- [27] A. Manada and N. Kashyap, "On the period of a periodic-finite-type shift," *Proc. IEEE Int. Symp. Inf. Theory*, Toronto, ON, Canada, July 7–11, 2008, pp. 1453–1457.
- [28] D. Knuth, "Strong components," Tech. Rep. 004639, Comput. Sci. Dep. Stanford Univ., Stanford, Calif., 1973.
- [29] Y. Balcer and A. F. Veinott, Jr., "Computing a graph's period quadratically by node condensation," *Discrete Math.*, vol. 4, pp. 295–303, 1973
- [30] M.-P. Béal, M. Crochemore, and L. Gasieniec, "Tries accepting periodic forbidden words," preprint, 2007.
- [31] I. P. Goulden and D. M. Jackson, "An inversion theorem for cluster decompositions of sequences with distinguished subsequences," *J. London Math. Soc.* (2), vol. 20, pp. 567–576, 1979.
- [32] I. P. Goulden and D. M. Jackson, *Combinatorial Enumeration*, A Wiley-Interscience Publication, John Wiley & Sons Inc., New York, 1983.
- [33] P. Flajolet and R. Sedgewick, *Analytic Combinatorics*. Book in preparation, (672 p.+x. Version of August 16, 2005 is available at <http://algo.inria.fr/flajolet/publist.html>).
- [34] J. Noonan and D. Zeilberger, "The Goulden-Jackson cluster method: extensions, applications and implementations," *J. Differ. Equations Appl.*, vol. 5, pp. 355–377, 1999.
- [35] N. T. Sindhushayana, "Symbolic dynamics and automata theory, with applications to constraint coding," Master's thesis, Cornell University, Ithaca, NY, July 1993.
- [36] P. A. McEwen, *Trellis Coding for Partial Response Channels*. Ph.D. thesis, University of California, San Diego, Apr. 1999.
- [37] M.-P. Béal and D. Perrin, "Symbolic dynamics and finite automata," in *Handbook of formal languages*, Vol. 2, Springer, Berlin, 1997, pp. 463–505.
- [38] B. E. Moision, A. Orlitsky, and P. H. Siegel, "On codes that avoid specified differences," *IEEE Trans. Inf. Theory*, vol. 47, no. 1, pp. 433–442, Jan. 2001.