

(19) World Intellectual Property
Organization
International Bureau



(43) International Publication Date
17 February 2005 (17.02.2005)

PCT

(10) International Publication Number
WO 2005/013853 A2

- (51) International Patent Classification⁷: **A61F**
- (21) International Application Number:
PCT/US2004/025381
- (22) International Filing Date: 6 August 2004 (06.08.2004)
- (25) Filing Language: English
- (26) Publication Language: English
- (30) Priority Data:
10/637,713 8 August 2003 (08.08.2003) US
- (71) Applicant (for all designated States except US): **XTENT, INC.** [US/US]; 604-D Fifth Avenue, Redwood City, California 94063 (US).
- (72) Inventors; and
- (75) Inventors/Applicants (for US only): **ACOSTA, Pablo** [US/US]; 8272 Rinconada Court, Newark, California 94062 (US). **ANDREAS, Bernard** [US/US]; 633 California Way, Redwood City, California 94062 (US). **LANDREVILLE, Steve** [US/US]; 273 Mountain View Avenue, Mountain View, California 94041 (US). **CHEW, Sunmi** [US/US]; 1599 Martin Avenue, San Jose, CA 95123 (US).
- (74) Agents: **SMITH, Scott, M.** et al.; **TOWNSEND AND TOWNSEND AND CREW LLP**, Two Embarcadero Center, 8th Floor, San Francisco, California 94111-3834 (US).
- (81) Designated States (unless otherwise indicated, for every kind of national protection available): AE, AG, AL, AM, AT, AU, AZ, BA, BB, BG, BR, BW, BY, BZ, CA, CH, CN, CO, CR, CU, CZ, DE, DK, DM, DZ, EC, EE, EG, ES, FI, GB, GD, GE, GH, GM, HR, HU, ID, IL, IN, IS, JP, KE, KG, KP, KR, KZ, LC, LK, LR, LS, LT, LU, LV, MA, MD, MG, MK, MN, MW, MX, MZ, NA, NI, NO, NZ, OM, PG, PH, PL, PT, RO, RU, SC, SD, SE, SG, SK, SL, SY, TJ, TM, TN, TR, TT, TZ, UA, UG, US, UZ, VC, VN, YU, ZA, ZM, ZW.
- (84) Designated States (unless otherwise indicated, for every kind of regional protection available): ARIPO (BW, GH, GM, KE, LS, MW, MZ, NA, SD, SL, SZ, TZ, UG, ZM, ZW), Eurasian (AM, AZ, BY, KG, KZ, MD, RU, TJ, TM), European (AT, BE, BG, CH, CY, CZ, DE, DK, EE, ES, FI, FR, GB, GR, HU, IE, IT, LU, MC, NL, PL, PT, RO, SE, SI, SK, TR), OAPI (BF, BJ, CF, CG, CI, CM, GA, GN, GQ, GW, ML, MR, NE, SN, TD, TG).
- Published:**
— without international search report and to be republished upon receipt of that report
- For two-letter codes and other abbreviations, refer to the "Guidance Notes on Codes and Abbreviations" appearing at the beginning of each regular issue of the PCT Gazette.

(54) Title: APPARATUS AND METHODS FOR DEPLOYMENT OF VASCULAR PROSTHESES

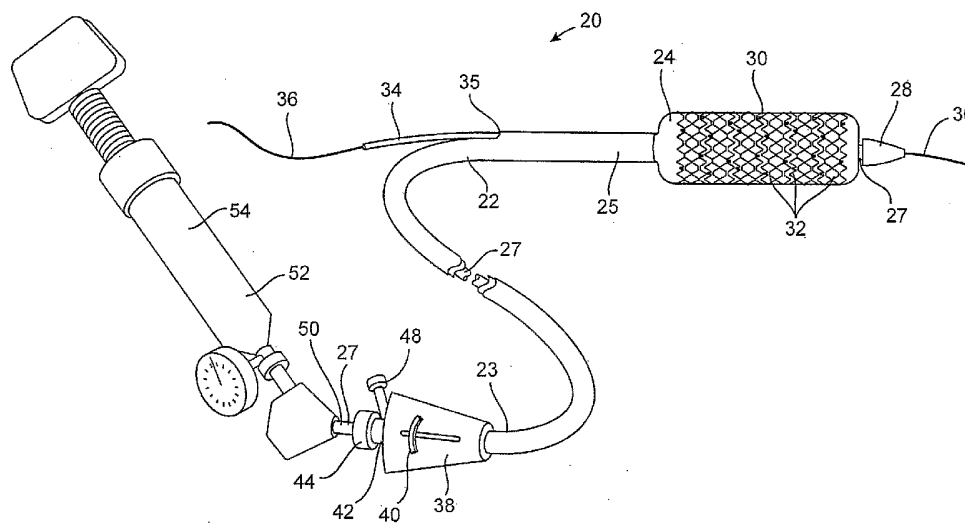

(57) Abstract: Apparatus for delivering stents to body lumens include one or more tubular prostheses carried at the distal end of a catheter shaft, a sheath slidably disposed over the prostheses, and a guidewire tube extending from within the sheath to the exterior of the sheath through an exit port in a sidewall thereof. A guidewire extends slidably through the guidewire tube. The sheath can be moved relative to the catheter shaft and the guidewire tube to expose the prostheses for deployment. Methods of delivering stents are also provided.

WO 2005/013853 A2

APPARATUS AND METHODS FOR DEPLOYMENT OF VASCULAR PROSTHESES

CROSS-REFERENCES TO RELATED APPLICATIONS

[0001] This application is a continuation-in-part of co-pending application Serial No. 10/412,714, filed April 10, 2003 (Attorney Docket No. 21629-000330), which is a continuation-in-part of application Serial No. 10/306,813, filed November 27, 2002 (Attorney Docket No. 21629-000320), which is a non-provisional of provisional application Serial No. 60/336,767, filed December 3, 2001 (Attorney Docket No. 21629-000300), and a non-provisional of provisional application Serial No. 60/364,389, filed March 13, 2002 (Attorney Docket No. 21629-000310), the disclosures of which are incorporated herein by reference.

FIELD OF THE INVENTION

[0002] This invention relates generally to vascular catheters, and more specifically to stents and stent delivery catheters for deployment in the coronary arteries and other vessels.

BACKGROUND OF THE INVENTION

[0003] Stenting has become an increasingly important treatment option for patients with coronary artery disease. Stenting involves the placement of a tubular prosthesis within a diseased coronary artery to expand the arterial lumen and maintain the patency of the artery. Early stent technology suffered from problems with restenosis, the tendency of the coronary artery to become re-occluded following stent placement. However, in recent years, improvements in stent design and the advent of drug-eluting stents have reduced restenosis rates dramatically. As a result, the number of stenting procedures being performed in the United States, Europe, and elsewhere has soared.

[0004] Stents are delivered to the coronary arteries using long, flexible vascular catheters typically inserted through a femoral artery. For self-expanding stents, the stent is simply released from the delivery catheter and it resiliently expands into engagement with the vessel wall. For balloon expandable stents, a balloon on the delivery catheter is expanded which expands and deforms the stent to the desired diameter, whereupon the balloon is deflated and removed.

[0005] Current stent delivery technology, however, suffers from a number of drawbacks. For example, current stent delivery catheters are not capable of customizing the length of the stent *in situ* to match the size of the lesion to be treated. While lesion size may be measured prior to stenting using angiography or fluoroscopy, such measurements may be inexact. If a stent is introduced that is found to be of inappropriate size, the delivery catheter and stent must be removed from the patient and replaced with a different device of correct size.

[0006] Moreover, current stent delivery devices cannot treat multiple lesions with a single catheter. Current devices are capable of delivering only a single stent with a single catheter, and if multiple lesions are to be treated, a new catheter and stent must be introduced for each lesion to be treated.

[0007] Further, current stent delivery devices are not well-adapted for treating vascular lesions that are very long and/or in curved regions of a vessel. Current stents have a discrete length that is relatively short due to their stiffness. If current stents were made longer so as to treat longer lesions, they would not conform well to the curvature of vessels or to the movement of vessels on the surface of the beating heart. On the other hand, any attempt to place multiple stents end-to-end in longer lesions is hampered by the inability to maintain appropriate inter-stent spacing and to prevent overlap of adjacent stents.

[0008] Additionally, some stent delivery catheters and angioplasty balloon catheters, particularly those having movable external sheaths to enclose the stent or balloon, suffer from poor tracking and cumbersome interaction with guidewires. Some such catheters utilize an "over-the-wire" design in which the guidewire extends through an inner lumen of the catheter from its proximal end to its distal end, a design that makes catheter exchanges cumbersome and time-consuming. Rapid exchange designs have also been proposed for such catheters wherein the guidewire extends through the distal end of the catheter and out through a port in a sidewall of the sheath. However, in these designs the guidewire inhibits smooth retraction of the sheath and, if the sheath is retracted a substantial distance, the port can become so displaced from the distal end of the catheter that the guidewire does not slide smoothly as the catheter is moved.

[0009] Finally, many stent delivery catheters suffer from inflexibility and high cross-sectional profile, which hamper endovascular positioning.

[0010] For these and other reasons, stents and stent delivery catheters are needed which enable the customization of stent length *in situ*, and the treatment of multiple lesions of

various sizes, without requiring removal of the delivery catheter from the patient. Such stents and stent delivery catheters should be capable of treating lesions of particularly long length and lesions in curved regions of a vessel, and should be highly flexible to conform to vessel shape and movement. Such stent delivery catheters should further be of minimal cross-sectional profile and should be highly flexible for endovascular positioning through tortuous vascular pathways.

BRIEF SUMMARY OF THE INVENTION

[0011] The invention provides apparatus and methods for delivering prostheses or stents into body lumens. In one aspect of the invention, an apparatus for delivering a prosthesis into a target vessel comprises a flexible catheter shaft having proximal and distal ends and a first lumen therein. A tubular prosthesis is releasably carried near the distal end of the catheter shaft and is expandable to a shape suitable for engaging the target vessel. A sheath is disposed over the catheter shaft and the tubular prosthesis and is axially movable relative thereto. The sheath has proximal and distal ends, a sidewall, and an exit port in the sidewall between the proximal and distal ends. A guidewire tube extends through the exit port and has a distal extremity disposed within the tubular prosthesis and a proximal extremity disposed outside of the sheath, the guidewire tube being adapted for slidably receiving a guidewire therethrough.

[0012] Preferably, the guidewire tube is slidable through the exit port so that the sheath slides relative to the guidewire tube as it is retracted to expose the prosthesis for deployment. In one embodiment, the exit port is fluidly sealed around the guidewire tube so as to limit the introduction of blood into the interior of the sheath and limit the flow of flushing fluids from within the sheath into the vessel. Usually the guidewire tube is fixed relative to the catheter shaft, and may be attached thereto. If an expandable member is mounted to the catheter shaft for prosthesis expansion, the guidewire tube may extend through and attach to the expandable member.

[0013] Because the guidewire tube exits the sheath in a distal extremity thereof, the sheath has a low profile portion proximal to the exit port that has a smaller diameter than the portion distal to the exit port. Not only does this reduce the cross-sectional profile, but increases the flexibility of the device.

[0014] The exit port may be cut into the sidewall of the sheath to face laterally, or alternatively oriented so as to face generally in a proximal direction. The exit port is usually positioned so as to be closer to the distal end of the sheath than to the proximal end thereof, and is preferably a distance of about 20-35 cm from the distal end of the sheath. With the sheath advanced fully distally over the catheter shaft, the proximal extremity of the guidewire lumen exposed outside the sheath is preferably about 3-15 cm in length, although various lengths are possible, even as long or longer than the catheter shaft itself. The proximal end of the guidewire tube is preferably disposed a distance of less than about one-half the length of the catheter shaft from the distal end thereof, but in some embodiments may extend further proximally, even as far as the proximal end of the catheter shaft.

[0015] The apparatus of the invention may be configured to deliver tubular prostheses that are either self-expanding or expandable by a balloon or other expandable member. When self-expanding prostheses are used, the sheath is adapted to constrain the prosthesis in a collapsed configuration. Upon retraction of the sheath, the prosthesis is released and self-expands to engage the vessel.

[0016] For balloon-expandable prostheses, an expandable member is mounted to the catheter shaft near the distal end thereof. The tubular prosthesis is positionable over the expandable member for expansion therewith. Usually the expandable member will comprise a balloon in communication with an inflation lumen in the catheter shaft for delivery of inflation fluid to the balloon. The sheath is axially positionable relative to the expandable member and configured to restrain expansion of a selected portion of the expandable member. Preferably the sheath is reinforced to prevent expansion thereof by the expandable member.

[0017] In a preferred aspect of the invention, the tubular prosthesis comprises a plurality of prosthesis segments. The sheath is axially movable relative to the prosthesis segments and configured to restrain expansion of a selectable number of prosthesis segments. In this way, lesions of various lengths may be treated by adjusting the length of the prosthesis *in situ*, without removal of the device from the body. In these embodiments, a pusher may be slidably disposed over the catheter shaft within the sheath. The pusher has a distal end in engagement with the tubular prosthesis for moving the tubular prosthesis relative to the catheter shaft.

[0018] In a further aspect of the invention, a method of delivering a prosthesis in a target vessel of a patient comprises inserting a guidewire through the patient's vasculature to the target vessel; slidably coupling a delivery catheter to the guidewire, the delivery catheter having a sheath and a guidewire tube, a proximal extremity of the guidewire tube being outside the sheath and a distal extremity of the guidewire tube being inside the sheath, the guidewire being slidably positioned through the guidewire tube; advancing the delivery catheter over the guidewire to the target vessel; retracting the sheath relative to the guidewire tube to expose a tubular prosthesis carried by the delivery catheter; and expanding the tubular prosthesis into engagement with the target vessel.

[0019] Usually, the guidewire tube will extend through an exit port in the sheath, and the guidewire tube will slide through the exit port as the sheath is retracted. Optionally, the method may include sealing the exit port around the guidewire tube to restrict fluid flow therethrough.

[0020] In a preferred embodiment, an expandable member is fixed to a catheter shaft over which the sheath is disposed, and the tubular prosthesis is positionable over the expandable member. The tubular prosthesis will then be expanded by expanding the expandable member. The sheath may be used to cover a proximal portion of the expandable member to constrain the proximal portion from expansion while a distal portion of the expandable member expands. Usually, the expandable member is inflatable and will be inflated by delivering inflation fluid to the expandable member through an inflation lumen in the catheter shaft. The guidewire tube preferably extends through the interior of the expandable member, which may be attached to the guidewire tube.

[0021] In a preferred aspect of the invention, the tubular prosthesis comprises a plurality of prosthesis segments, and the method includes positioning a first selected number of the prosthesis segments on the expandable member for expansion therewith. The method may further include positioning the sheath over a second selected number of the prosthesis segments to constrain expansion thereof. The first selected number of prosthesis segments may be positioned on the expandable member by pushing the first selected number with a pusher that is axially slidable relative to the expandable member.

[0022] In alternative embodiments, the tubular prosthesis self-expands when the sheath is retracted. In embodiments in which the prosthesis comprises multiple prosthesis segments,

the sheath may be retracted relative to a selected number of such segments to allow the segments to self-expand into contact with the vessel.

[0023] In another aspect, the invention provides a balloon catheter for treating a target vessel that includes a flexible catheter shaft having proximal and distal ends and a first lumen therein. An expandable member is connected to the catheter shaft, and a sheath is disposed over the catheter shaft and the expandable member and is axially movable relative thereto. The sheath has an exit port in a sidewall thereof between its proximal and distal ends. A guidewire tube extends through the exit port and has a proximal extremity disposed outside of the sheath and a distal extremity disposed within the sheath that is coupled to the catheter shaft or the expandable member. The guidewire tube is adapted for slidably receiving a guidewire therethrough. The expandable member preferably comprises a balloon in fluid communication with the first lumen to receive inflation fluid therefrom. The sheath may be positionable to constrain a first selected portion of the expandable member from expansion while a second selected portion of the expandable member expands.

[0024] In a preferred embodiment of the balloon catheter of the invention, a tubular prosthesis is disposed on the expandable member and is expandable therewith. The tubular prosthesis will preferably comprise a plurality of unconnected stent segments that are slidable relative to the expandable member. The sheath is positionable to expose a first selected portion of the stent segments while covering a second selected portion of the stent segments.

[0025] In yet another aspect of the invention, an apparatus for delivering a prosthesis into a target vessel comprises a flexible catheter shaft having proximal and distal ends and a tubular prosthesis slidably coupled to the catheter shaft, the tubular prosthesis being expandable to a shape suitable for engaging the target vessel. A pusher is provided for moving the tubular prosthesis from a pre-deployment position to a deployment position near the distal end of the catheter shaft. The apparatus further includes a stop on the catheter shaft configured to engage the tubular prosthesis when the tubular prosthesis is in the deployment position.

[0026] In one embodiment, an expandable member is coupled to the catheter shaft and the tubular prosthesis is adapted for expansion by the expandable member. The expandable member, e.g. balloon, has an interior, and the stop is preferably disposed within the interior of the expandable member. Alternatively, the tubular prosthesis is self-expanding and expands upon being released from the catheter shaft.

[0027] In a preferred aspect, a plurality of tubular prostheses are slidably coupled to the catheter shaft and are movable by the pusher to the deployment position. In addition, a sheath may be movably coupled to the catheter shaft and positionable over the tubular prosthesis or prostheses.

[0028] In a further method of deploying a tubular prosthesis in a target vessel according to the invention a catheter shaft is positioned in a target vessel and the tubular prosthesis is moved distally relative to the catheter shaft while the catheter shaft remains in the target vessel until the prosthesis engages a stop near the distal end of the catheter shaft. The tubular prosthesis is then expanded to engage a wall of the target vessel.

[0029] After expanding the tubular prosthesis, a second prosthesis (or any number of additional prostheses) may be moved distally relative to the catheter shaft until the second prosthesis engages the stop, and the second prosthesis then expanded to engage a wall of the target vessel. Alternatively, a second prosthesis may be moved distally relative to the catheter shaft simultaneously with moving the tubular prosthesis, and both the second prosthesis and the tubular prosthesis are expanded together to engage the wall of the target vessel. Usually, the tubular prosthesis and any additional prostheses are moved by a pusher movably coupled to the catheter shaft.

[0030] The tubular prosthesis is preferably expanded by inflating a balloon coupled to the catheter shaft. Alternatively, the tubular prosthesis may be self-expandable.

[0031] Further, the method may include retaining a second prosthesis in an unexpanded configuration on the catheter shaft while the tubular prosthesis is expanded. In one embodiment, the second prosthesis is retained within a sheath movably coupled to the catheter shaft.

[0032] Further aspects of the nature and advantages of the invention will become apparent from the detailed description below taken in conjunction with the drawings.

BRIEF DESCRIPTION OF THE DRAWINGS

[0033] Fig. 1 is a perspective view of a stent delivery catheter according to the invention with sheath retracted and expandable member inflated.

[0034] Fig. 2A is a side cross-section of a distal portion of the stent delivery catheter of Fig. 1 with expandable member deflated and sheath advanced distally.

[0035] Fig. 2B is a side cross-section of a distal portion of the stent delivery catheter of Fig. 1 with expandable member inflated and sheath retracted.

[0036] Fig. 3 is a transverse cross-section through line 3-3 of Fig. 2A.

[0037] Fig. 4 is a transverse cross-section through line 4-4 of Fig. 2A.

[0038] Fig. 5A is a side view of a first embodiment of a stent segment according to the invention in an unexpanded configuration.

[0039] Fig. 5B is a side view of the stent segment of Fig. 5A in an expanded configuration.

[0040] Fig. 6A is a side view of a second embodiment of a stent segment according to the invention in an unexpanded configuration.

[0041] Fig. 6B is a side view of two of the stent segments of Fig. 6A in an expanded configuration.

[0042] Figs. 7A-7E are side cut-away views of the stent delivery catheter of the invention positioned in a vessel with the stent segments of Figs. 5A-5B, illustrating various steps of delivering a prosthesis according to the method of the invention.

[0043] Fig. 8 is a side cut-away view of the stent delivery catheter of the invention positioned in a vessel with the stent segments of Figs. 6A-6B in a deployed configuration.

DETAILED DESCRIPTION OF THE INVENTION

[0044] A first embodiment of a stent delivery catheter according to present invention is illustrated in Fig. 1. Stent delivery catheter 20 includes a catheter body 22 comprising an outer sheath 25 slidably disposed over an inner shaft 27. An expandable member 24, preferably an inflatable balloon (shown in an inflated configuration), is mounted to inner shaft 27 and is exposed by retracting sheath 25 relative to inner shaft 27. A tapered nosecone 28, composed of a soft elastomeric material to reduce trauma to the vessel during advancement of the device, is mounted distally of expandable member 24. A stent 30, which preferably comprises a plurality of separate or separable stent segments 32, is disposed on expandable member 24 for expansion therewith. A guidewire tube 34 is slidably positioned through a guidewire tube exit port 35 in sheath 25 proximal to expandable member 24. A

guidewire 36 is positioned slidably through guidewire tube 34, expandable member 24, and nosecone 28 and extends distally thereof.

[0045] A handle 38 is mounted to a proximal end 23 of sheath 25 and includes an actuator 40 slidably mounted thereto for purposes described below. An adaptor 42 is mounted to the proximal end of handle 38 and provides a catheter port 44 through which inner shaft 27 is slidably positioned. A flush port 48 is mounted to the side of adaptor 42 through which a fluid such as saline can be introduced into the interior of catheter body 22. An annular seal (not shown) in catheter port 44 seals around inner shaft 27 to prevent fluid from leaking through catheter port 44. Optionally, a clamp (not shown) such as a threaded collar, can be mounted to catheter port 44 to lock inner shaft 27 relative to handle 38.

[0046] Inner shaft 27 has a proximal end 50 to which is mounted an inflation adaptor 52. Inflation adaptor 52 is configured to be fluidly coupled to an inflation device 54, which may be any commercially available balloon inflation device such as those sold under the trade name "Indeflator™," available from Advanced Cardiovascular Systems of Santa Clara, CA. Inflation adaptor 52 is in fluid communication with expandable member 24 via an inflation lumen (described below) in inner shaft 27 to enable inflation of expandable member 24.

[0047] Referring now to Figs. 2A-2B, 3 and 4, which show a distal portion of the stent delivery catheter in cross-section, it may be seen that sheath 25 may be extended up to nosecone 28 to fully surround expandable member 24 and stent segments 32. One or more radiopaque markers 56 are mounted near a distal end 57 of sheath 25 to facilitate visualization of the position of sheath 25 using fluoroscopy. In a preferred embodiment, two annular markers 56 are spaced apart a length equal to the length of one of stent segments 32 for purposes described more fully below. Sheath 25 further includes a valve member 58 preferably spaced proximally from distal end 57 a distance equal to the length of one of stent segments 32. Valve member 58 has an inwardly extending flange 60 configured to frictionally engage stent segments 32 and thereby restrict the sliding movement of stent segments 32 distally relative to sheath 25. Flange 60 may be a polymeric material integrally formed with sheath 25 or a separate annular member bonded or otherwise mounted to sheath 25. Various embodiments of valve member 58 are described in copending application Serial No. 10/412,714, Filed April 10, 2003 (Attorney Docket No. 21629-000330), which is incorporated herein by reference.

[0048] Sheath 25 has a distal extremity 62 configured to surround expandable member 24 and stent segments 32 disposed thereon when in an unexpanded configuration. Distal extremity 62 extends proximally to a junction 63, preferably aligned with the location of guidewire tube exit port 35, where distal extremity 62 is joined to a proximal extremity 64 that extends proximally to handle 38 (see Fig. 1). In a preferred embodiment, distal extremity 62 has a length of about 15-35 cm and proximal extremity 64 as a length of about 100-125 cm. Proximal extremity 64 may be constructed of a variety of biocompatible polymers or metals, preferably being stainless steel or Nitinol. Distal extremity 62 may be a polymer such as PTFE, FEP, polyimide, or Pebax, and is preferably reinforced with a metallic or polymeric braid to resist radial expansion when expandable member 24 is expanded.

[0049] Preferably, proximal extremity 64 has a smaller transverse dimension than distal extremity 62 to accommodate the added width of guidewire tube 34 within the vessel lumen, as well as to maximize flexibility and minimize profile. In one embodiment, shown in Fig. 3, distal extremity 62 is a tubular member having a first outer diameter, preferably about 1.0-1.5 mm, and proximal extremity 64 is a tubular member having a second, smaller outer diameter, preferably about 0.7-1.0 mm. At the junction of proximal extremity 64 with distal extremity 62, a proximally-facing crescent-shaped opening 65 is formed between the two tubular members that creates guidewire tube exit port 35. Excess space within crescent-shaped opening 65 may be filled with a filler material such as adhesive.

[0050] In an alternative embodiment (not shown), a hole is formed in the sidewall of distal extremity 62 or proximal extremity 64 to create guidewire tube exit port 35. Proximally of guidewire tube exit port 35, the wall of sheath 25 adjacent to guidewire tube 34 is flattened or collapsible inwardly thereby reducing the transverse dimension of sheath 25 to accommodate the width of guidewire tube 34.

[0051] Guidewire tube 34 is slidably positioned through guidewire tube exit port 35. Preferably, guidewire tube exit port 35 is configured to provide a total or partial fluid seal around the periphery of guidewire tube 34 to limit blood flow into the interior of sheath 25 and to limit leakage of saline (or other flushing fluid) out of sheath 25. This may be accomplished by sizing guidewire tube exit port 35 appropriately so as to form a fairly tight frictional seal around guidewire tube 34 while still allowing the sliding motion thereof relative to sheath 25. Alternatively an annular sealing ring may be mounted in guidewire tube exit port 35 to provide the desired seal.

[0052] Guidewire tube exit port 35 will be positioned to provide optimal tracking of stent delivery catheter 20 through the vasculature and maximizing the ease with which the catheter can be inserted onto and removed from a guidewire to facilitate catheter exchanges. Usually, guidewire tube exit port 35 will be positioned at a location proximal to expandable member 24 when sheath 25 is extended fully distally up to nosecone 28, but a distance of no more than one-half the length of sheath 25 from distal end 57. In preferred embodiments for coronary applications, guidewire tube exit port 35 is spaced proximally a distance of about 20-35 cm from the distal end 57 of sheath 25.

[0053] Guidewire tube 34 should extend proximally from guidewire tube exit port 35 a distance at least as long as the longest possible stent that may be deployed, e.g. 30-60 mm, to allow for retraction of sheath 25 that distance while retaining a portion of guidewire tube 34 external to sheath 25. Preferably guidewire tube 34 extends proximally a distance of about 3-15 cm from guidewire tube exit port 35 when sheath 25 is in a fully distal position, with the proximal end thereof disposed a distance of about 23-50 cm from the distal tip of nosecone 28. Where stent delivery catheter 20 is to be positioned through a guiding catheter, the proximal end of guidewire tube 34 will preferably be positioned so as to be within the guiding catheter when expandable member 24 is positioned at the target site for stent deployment. Guidewire tube 34 is preferably a highly flexible polymer such as PTFE, FEP, polyimide, or Pebax, and may optionally have a metal or polymer braid embedded in it to increase kink-resistance.

[0054] Inner shaft 27 forms an inflation lumen 66 that is in communication with interior of expandable member 24. In the distal extremity of stent delivery catheter 20 inner shaft 27 is preferably formed of a polymer such as PTFE, FEP, polyimide, or Pebax, and may be reinforced with a metallic braid for added radial strength and kink resistance. In the proximal extremity of delivery catheter 20, inner shaft 27 may be a similar polymer or a metal such as stainless steel or Nitinol.

[0055] Expandable member 24 has an expandable balloon member 70 that is joined to a non-expandable tubular leg 72. Expandable balloon member 70 is a semi-compliant polymer such as Pebax or Nylon. Tubular leg 72 is preferably a polymer such as polyimide, PTFE, FEP or Pebax and may optionally be reinforced with a metal or polymer braid. Tubular leg 72 has an open proximal end 74 through which guidewire tube 34 extends. Proximal end 74 of tubular leg 72 is fixed to distal end 68 of inner shaft 27 and to guidewire tube 34, forming

a fluid-tight seal. Balloon member 70 has a distal end 76 bonded to an annular stop 78, which is mounted to nosecone 28. Stop 78 has a size and shape selected to engage stent segment 32 and provide a stop against which stent segments 32 can be located in the ideal deployment position without being pushed beyond the distal end of balloon member 70. Guidewire tube 34 passes through the interior of balloon member 70 and is mounted to nosecone 28, thereby providing a passage through the distal portion of catheter body 22 through which guidewire 36 may pass.

[0056] Optionally, within the interior of balloon member 70 an annular base member 80 is mounted to guidewire tube 34 and has a diameter selected to urge balloon member 70 against stent segments 32 in their unexpanded configuration, thereby providing frictional engagement with stent segments 32. This helps to limit unintended sliding movement of stent segments 32 on balloon member 70. Base member 80 may be made of a soft elastomer, foam, or other compressible material. Adjacent to the distal and proximal ends of base member 80 two annular radiopaque markers 82 are mounted to guidewire tube 34, facilitating visualization of the location of balloon member 70 with fluoroscopy and enabling appropriate positioning of stent segments 32 on balloon member 70. Alternatively, only a single marker 82 at the distal end of base member 80 may be used, or markers may be placed at other locations on nosecone 28, guidewire tube 34, or inner shaft 27. Such markers may be made of various radiopaque materials such as platinum/iridium, tantalum, and other materials.

[0057] Stent segments 32 are slidably positioned over balloon member 70. Depending upon the number of stent segments 32 loaded in stent delivery catheter 20, stent segments 32 may be positioned over both balloon member 70 and tubular leg 72. In an exemplary embodiment, each stent segment is about 2-8 mm in length, and up to 10-50 stent segments may be positioned end-to-end in a line over balloon member 70 and tubular leg 72. Stent segments 32 preferably are in direct contact with each other, but alternatively separate spacing elements may be disposed between adjacent stent segments, the spacing elements being movable with the stent segments along balloon member 70. Such spacing elements may be plastically deformable or self-expanding so as to be deployable with stent segments 32 into the vessel, but alternatively could be configured to remain on balloon member 70 following stent deployment; for example, such spacing elements could comprise elastic rings which elastically expand with balloon member 70 and resiliently return to their unexpanded shape when balloon member 70 is deflated. The spacing elements could be pushed to the

distal end of balloon member 70 against stop 78 as additional stent segments 32 are advanced distally.

[0058] Stent segments 32 are preferably a malleable metal so as to be plastically deformable by expandable member 24 as they are expanded to the desired diameter in the vessel. Alternatively, stent segments 32 may be formed of an elastic or super elastic shape memory material such as Nitinol so as to self-expand upon release into the vessel by retraction of sheath 25. Stent segments 32 may also be composed of polymers or other suitable biocompatible materials. In self-expanding embodiments, expandable member 24 may also be used for predilatation of a lesion prior to stent deployment or for augmenting the expansion of the self-expanding stent segments.

[0059] In preferred embodiments, stent segments 32 are coated with a drug that inhibits restenosis, such as Rapamycin, Paclitaxel, analogs, prodrugs, or derivatives of the foregoing, or other suitable agent, preferably carried in a bioerodable polymeric carrier. Alternatively, stent segments 32 may be coated with other types of drugs and therapeutic materials such as antibiotics, thrombolytics, anti-thrombotics, anti-inflammatories, cytotoxic agents, anti-proliferative agents, vasodilators, gene therapy agents, radioactive agents, immunosuppressants, and chemotherapeutics. Such materials may be coated over all or a portion of the surface of stent segments 32, or stent segments 32 may include apertures, holes, channels, or other features in which such materials may be deposited.

[0060] Stent segments 32 may have a variety of configurations, including those described in copending application Serial No. 60/440839, filed January 17, 2003 (Attorney Docket No. 21629-000500), which is incorporated herein by reference. Other preferred stent configurations are described below. Stent segments 32 are preferably completely separate from one another without any interconnections, but alternatively may have couplings between two or more adjacent segments which permit flexion between the segments. As a further alternative, one or more adjacent stent segments may be connected by separable or frangible couplings that are separated prior to or upon deployment, as described in copending application Serial No. 10/306,813, filed November 27, 2002 (Attorney Docket No. 21629-000320), which is incorporated herein by reference.

[0061] A pusher tube 86 is slidably disposed over inner shaft 27 and has a distal extension 88 coupled to a pusher ring 90. Pusher ring 90 is slidable over tubular leg 72 and engages the stent segment 32 at the proximal end of the line of stent segments 32. At its proximal end

(not shown), pusher tube 86 is coupled to sliding actuator 40 on handle 38 (see Fig. 1). In this way pusher tube 86 can be advanced distally relative to inner shaft 27 to urge stent segments 32 distally over expandable member 24 (or pusher tube 86 may be held in position while retracting expandable member 24 relative to stent segments 32) until the stent segments engage stop 78. In addition, pusher tube 86 can be used to hold stent segments 32 in place on expandable member 24 while sheath 25 is retracted to expose a desired number of stent segments 32, as shown in Fig. 2B. Pusher tube 86 may be constructed of a variety of biocompatible polymers or metals, preferably being stainless steel or Nitinol. Distal extension 88 and pusher ring 90 may be a polymer such as PTFE, FEP, polyimide, or Pebax, and are preferably reinforced with a metallic or polymeric braid to resist radial expansion when expandable member 24 is expanded.

[0062] It can be seen that with sheath 25 retracted a desired distance, expandable member 24 is allowed to expand when inflation fluid is delivered through inflation lumen 66, thereby expanding a desired number of stent segments 32 exposed distally of sheath 25. The remaining portion of expandable member 24 and the remaining stent segments 32 within sheath 25 are constrained from expansion by sheath 25.

[0063] Fig. 2B further illustrates that when sheath 25 is retracted relative to expandable member 24, guidewire tube exit port 35 becomes further away from the point at which guidewire 36 exits the proximal end 74 of tubular leg 72, increasing the distance that guidewire 36 must pass within the interior of sheath 25. Advantageously, guidewire tube 34 provides a smooth and continuous passage from the tubular leg 72 through guidewire tube exit port 35, eliminating any problems that might result from changing the alignment of the two. This is particularly important in the present invention where the stent delivery catheter may carry a large number of stent segments 32 and sheath 25 may be retracted a substantial distance relative to expandable member 24, resulting in substantial misalignment of guidewire tube exit port 35 relative to tubular leg 72.

[0064] In order to confirm the positioning of stent segments 32 on expandable member 24, fluoroscopy is used to visualize stent segments 32 relative to markers 82 on inner shaft 27. In addition, by fluoroscopic visualization of markers 56 on sheath 25 the user can see the extent of retraction of sheath 25 relative to expandable member 24 and view the location of the exposed stent segments 32 relative to sheath 25. Visualization of stent segments 32 is further enhanced with the use of radiopaque markers and/or materials in or on the stent segments

themselves. Markers of radiopaque materials may be applied to the exterior of stent segments 32, e.g, by applying a metal such as gold, platinum, a radiopaque polymer, or other suitable coating or mark on all or a portion of the stent segments. Alternatively, stent segments 32 may include a radiopaque cladding or coating or may be composed of radiopaque materials such as L-605 cobalt chromium (ASTM F90), other suitable alloys containing radiopaque elements, or multilayered materials having radiopaque layers. In yet another alternative, stent segments 32 may have a geometry conducive to fluoroscopic visualization, such as having struts of greater thickness, sections of higher density, or overlapping struts. Some of the possible materials that may be used in stent segments 32 include (by ASTM number):

- [0065] F67-00 Unalloyed Titanium
- [0066] F75-01 Cobalt-28 Chromium-6 Molybdenum Alloy
- [0067] F90-01 Wrought Cobalt-20 Chromium-15 Tungsten-10 Nickel Alloy
- [0068] F136-02a Wrought Titanium-6 Aluminum-4 Vanadium ELI Alloy
- [0069] F138-00, F139-00 Wrought 18 Chromium-14 Nickel-2.5 Molybdenum Stainless Steel Bar or Sheet
- [0070] F560-98 Unalloyed Tantalum
- [0071] F562-02 Wrought 35 Cobalt-35 Nickel-20 Chromium-10 Molybdenum Alloy
- [0072] F563-00 Wrought Cobalt-20 Nickel-20 Chromium 3.5 Molybdenum-3.5 Tungste-5 Iron Alloy
- [0073] F688 Wrought Cobalt-35 Nickel-20 Chromium-10 Molybdenum Alloy
- [0074] F745-00 18 Chromium-12.5 Nickel-2.5 Molybdenum Stainless Steel
- [0075] F799-02 Cobalt-28 Chromium-6 Molybdenum Alloy
- [0076] F961-96 Cobalt-35 Nickel-20 Chromium-10 Molybdenum Alloy
- [0077] F1058-02 Wrought 40 Cobalt-20 Chromium-16 Iron-15 Nickel-7 Molybdenum Alloy
- [0078] F1091-02 Wrought Cobalt-20 Chromium-15 Tungsten-10 Nickel Alloy
- [0079] F1108 Titanium-6 Aluminum-4 Vanadium Alloy

- [0080] F1295-01 Wrought Titanium-6 Aluminum-7 Niobium Alloy
- [0081] F1314-01 Wrought Nitrogen-strengthened 22 Chromium-13 Nickel-5 Manganese-2.5 Molybdenum Stainless Steel Alloy
- [0082] F1241-99 Unalloyed Titanium Wire
- [0083] F1350-02 Wrought 18 Chromium-14 Nickel-2.5 Molybdenum Stainless Steel Wire
- [0084] F1377-98a Cobalt-28 Chromium-6 Molybdenum Powder coating
- [0085] F1472-02a Wrought Titanium-6 Aluminum-4 Vanadium Alloy
- [0086] F1537-00 Wrought Cobalt-28 Chromium-6 Molybdenum Alloy
- [0087] F1580-01 Titanium and Titanium-6 Aluminum-4 Vanadium Alloy Powder coating
- [0088] F1586-02 Wrought Nitrogen Strengthened 21 Chromium-10 Nickel-3 Manganese-2.5 Molybdenum Stainless Steel Bar
- [0089] F1713-96 Wrought Titanium-13 Niobium-13 Zirconium Alloy
- [0090] F1813-01 Wrought Titanium-12 Molybdenum-6 Zirconium-2 Iron Alloy
- [0091] F2063-00 Wrought Nickel-Titanium Shape Memory Alloys
- [0092] F2066-01 Wrought Titanium-15 Molybdenum Alloy
- [0093] F2146-01 Wrought Titanium-3 Aluminum-2.5 Vanadium Alloy Seamless Tubing
- [0094] F2181-02a Wrought Stainless Steel Tubing

[0095] A first preferred geometry of stent segments 32 is illustrated in Figs. 5A-5B. Fig. 5A illustrates a portion of a stent segment 32 in an unexpanded configuration, shown in a planar shape for clarity. Stent segment 32 comprises two parallel rows 98A, 98B of I-shaped cells 100 formed around an axis A so that stent segment 32 has a cylindrical shape. Each cell 100 has upper and lower axial slots 102 aligned with the axial direction and a circumferential slot 104. Upper and lower slots 102 preferably have an oval, racetrack, rectangular or other oblong shape with a long dimension L generally parallel to axis A and a short dimension W perpendicular thereto. Axial slots 102 are bounded by upper axial struts 106 and lower axial struts 107, curved outer ends 108 and curved inner ends 110. Each circumferential slot 104 is bounded by an outer circumferential strut 109 and an inner circumferential strut 111. Each I-shaped cell 100 is connected to the adjacent I-shaped cell 100 in the same row 98A or 98B by

a circumferential connecting strut 113. All or a portion of cells 100 in row 98A merge or join with cells 100 in row 98B at the inner ends 110, which are integrally formed with the inner ends 110 of the adjacent cells 100.

[0096] In a preferred embodiment, a spacing member 112 extends outwardly in the axial direction from a selected number of outer circumferential struts 109 and/or connecting struts 113. Spacing member 112 preferably itself forms a subcell 114 in its interior, but alternatively may be solid without any cell or opening therein. For those spacing members 112 attached to outer circumferential struts 109, subcell 114 preferably communicates with I-shaped cell 100. Spacing members 112 are configured to engage the curved outer ends 108 of an adjacent stent segment 32 so as to maintain appropriate spacing between adjacent stent segments. In one embodiment, spacing members 112 have outer ends 116 with two spaced-apart protrusions 118 that provide a cradle-like structure to index and stabilize the curved outer end 108 of the adjacent stent segment. Preferably, spacing members 112 have an axial length of at least about 10%, more preferably at least about 25%, of the long dimension L of I-shaped cells 100, so that the I-shaped cells 100 of adjacent stent segments are spaced apart at least that distance. Because spacing members 112 experience little or no axial shortening during expansion of stent segments 32, this minimum spacing between stent segments is maintained both in the unexpanded and expanded configurations.

[0097] A first preferred geometry of stent segments 32 is illustrated in Figs. 5A-5B. Fig. 5A illustrates a portion of a stent segment 32 in an unexpanded configuration, shown in a planar shape for clarity. Stent segment 32 comprises two parallel rows 98A, 98B of I-shaped cells 100 formed around an axis A so that stent segment 32 has a cylindrical shape. Each cell 100 has upper and lower axial slots 102 aligned with the axial direction and a circumferential slot 104. Upper and lower slots 102 preferably have an oval, racetrack, rectangular or other oblong shape with a long dimension L generally parallel to axis A and a short dimension W perpendicular thereto. Axial slots 102 are bounded by upper axial struts 106 and lower axial struts 107, curved outer ends 108 and curved inner ends 110. Each circumferential slot 104 is bounded by an outer circumferential strut 109 and an inner circumferential strut 111. Each I-shaped cell 100 is connected to the adjacent I-shaped cell 100 in the same row 98A or 98B by a circumferential connecting strut 113. All or a portion of cells 100 in row 98A merge or join with cells 100 in row 98B at the inner ends 110, which are integrally formed with the inner ends 110 of the adjacent cells 100.

[0098] As an additional feature, circumferential slots 104 provide a pathway through which vessel side branches can be accessed for catheter interventions. Should stent segment 32 be deployed at a location in which it covers the ostium of a side branch to which access is desired, a balloon dilatation catheter may be positioned through circumferential slot 104 and expanded. This deforms circumferential struts 109, 111 axially outward, thereby expanding circumferential slot 104 and further expanding upper and lower slots 102, as shown in phantom in Fig. 3B. This provides a relatively large opening 120 through which a catheter may be inserted through stent segment 32 and into the side branch for placing stents, performing angioplasty, or carrying out other interventions.

[0099] Figs. 6A-6B illustrate a second embodiment of a stent segment 32 according to the invention. In Fig. 6A, a portion of stent segment 32 is shown in a planar shape for clarity. Similar to the embodiment of Fig. 5A, stent segment 32 comprises two parallel rows 122A, 122B of I-shaped cells 124 formed into a cylindrical shape around axial axis A. Cells 124 have upper and lower axial slots 126 and a connecting circumferential slot 128. Upper and lower slots 126 are bounded by upper axial struts 130, lower axial struts 132, curved outer ends 134, and curved inner ends 136. Circumferential slots 128 are bounded by outer circumferential strut 138 and inner circumferential strut 140. Each I-shaped cell 124 is connected to the adjacent I-shaped cell 124 in the same row 122 by a circumferential connecting strut 142. Row 122A is connected to row 122B by the merger or joining of curved inner ends 136 of at least one of upper and lower slots 126 in each cell 124.

[0100] One of the differences between the embodiment of Figs. 6A-6B and that of Figs. 5A-5B is the way in which spacing is maintained between adjacent stent segments. In place of the spacing members 112 of the earlier embodiment, the embodiment of Fig. 6A includes a bulge 144 in upper and lower axial struts 130, 132 extending circumferentially outwardly from axial slots 126. These give axial slots 126 an arrowhead or cross shape at their inner and outer ends. The bulge 144 in each upper axial strut 130 extends toward the bulge 144 in a lower axial strut 132 in the same cell 100 or in an adjacent cell 100, thus creating a concave abutment 146 in the space between each axial slot 126. Concave abutments 146 are configured to receive and engage curved outer ends 134 of cells 124 in the adjacent stent segment, thereby maintaining spacing between the stent segments. The axial location of bulges 144 along upper and lower axial struts 130, 132 may be selected to provide the desired degree of inter-segment spacing.

[0101] Fig. 6B shows two stent segments 32 of Fig. 6A in an expanded condition. It may be seen that axial slots 124 are deformed into a circumferentially widened modified diamond shape with bulges 144 on the now diagonal upper and lower axial struts 130, 132.

Circumferential slots 128 are generally the same size and shape as in the unexpanded configuration. Bulges 144 have been pulled away from each other to some extent, but still provide a concave abutment 146 to maintain a minimum degree of spacing between adjacent stent segments. As in the earlier embodiment, some axial shortening of each segment occurs upon expansion and stent geometry can be optimized to provide the ideal intersegment spacing.

[0102] It should also be noted that the embodiment of Figs. 6A-6B retains the feature described above with respect to Figs. 5A-5B to enable access to vessel side branches blocked by stent segment 32. Should such side branch access be desired, a dilatation catheter may be inserted into circumferential slot 128 and expanded to provide an enlarged opening through which a side branch may be entered.

[0103] Referring now to Figs. 7A-7E, the use of the stent delivery catheter of the invention will be described. While the invention will be described in the context of coronary artery treatment, the invention is useful in any of a variety of blood vessels and other body lumens in which stents are deployed, including the carotid, femoral, iliac and other arteries, as well as veins and other fluid-carrying vessels. A guiding catheter (not shown) is first inserted into a peripheral artery such as the femoral and advanced to the ostium of the target coronary artery. A guidewire GW is then inserted through the guiding catheter into the coronary artery A where lesion L is to be treated. The proximal end of guidewire GW is then inserted through nosecone 28 and guidewire tube 34 outside the patient's body and stent delivery catheter 20 is slidably advanced over guidewire GW and through the guiding catheter into the coronary artery A. Stent delivery catheter 20 is positioned through a lesion L to be treated such that nosecone 28 is distal to lesion L. During this positioning, sheath 25 is positioned distally up to nosecone 28 so as to surround expandable member 24 and all of the stent segments 32 thereon.

[0104] Optionally, lesion L may be predilated prior to stent deployment. Predilatation may be performed prior to introduction of stent delivery catheter 20 by inserting an angioplasty catheter over guidewire GW and dilating lesion L. Alternatively, stent delivery catheter 20 may be used for predilatation by retracting sheath 25 along with stent segments 32 to expose

an extremity of expandable member 24 long enough to extend through the entire lesion. This may be done while delivery catheter 20 is positioned proximally of lesion L or with expandable member 24 extending through lesion L. Fluoroscopy enables the user to visualize the extent of sheath retraction relative to lesion L by observing the position of marker 56 on sheath 25 relative to marker 82 at the distal end of expandable member 24. To allow stent segments 32 to move proximally relative to expandable member 24, force is released from pusher tube 86 and valve member 58 engages and draws the stent segments proximally with sheath 25. With the appropriate length of expandable member 24 exposed, expandable member 24 is positioned within lesion L and inflation fluid is introduced through inflation lumen 66 to inflate expandable member 24 distally of sheath 25 and thereby dilate lesion L. Expandable member 24 is then deflated and retracted within sheath 25 while maintaining force on pusher tube 86 so that stent segments 32 are positioned up to the distal end of expandable member 24, surrounded by sheath 25. Alternative embodiments of devices and methods for lesion predilatation are described in detail below.

[0105] Following any predilatation, stent delivery catheter 20 is repositioned in artery A so that nosecone 28 is distal to lesion L as shown in Fig. 7A. Sheath 25 is then retracted as in Fig. 7B to expose the appropriate number of stent segments 32 to cover lesion L. Again, fluoroscopy can be used to visualize the position of sheath 25 by observing marker 56 thereon relative to marker 82 within expandable member 24. As sheath 25 is drawn proximally, force is maintained against pusher tube 86 so that stent segments 32 remain positioned up to the distal end of expandable member 24. It should also be noted that sheath 25 moves proximally relative to guidewire tube 34, which slides through guidewire tube exit port 35. Advantageously, regardless of the position of sheath 25, guidewire tube 34 provides a smooth and continuous passage for guidewire GW so that stent delivery catheter slides easily over guidewire GW.

[0106] With the desired number of stent segments 32 exposed distally of sheath 25, it is frequently desirable to create some spacing between the stent segments to be deployed and those remaining enclosed within sheath 25. This reduces the risk of dislodging or partially expanding the distal-most stent segment 32 within sheath 25 when expandable member 24 is inflated. Such spacing is created, as shown in Fig. 7C, by releasing force against pusher tube 86 and retracting sheath 25 further proximally a short distance. The engagement of valve member 58 with stent segments 32 moves those stent segments 32 within sheath 25 away

from those stent segments 32 distal to sheath 25. The length of this spacing is preferably equal to the length of about $\frac{1}{2}$ -1 stent segment.

[0107] Expandable member 24 is then inflated by delivering inflation fluid through inflation lumen 66, as shown in Fig. 7D. The exposed distal portion of expandable member 24 expands so as to expand stent segments 32 thereon into engagement with lesion L. If predilatation was not performed, lesion L may be dilated during the deployment of stent segments 32 by appropriate expansion of expandable member 24. Sheath 25 constrains the expansion of the proximal portion of expandable member 24 and those stent segments 32 within sheath 25.

[0108] Expandable member 24 is then deflated, leaving stent segments 32 in a plastically-deformed, expanded configuration within lesion L, as shown in Fig. 7E. The alternative embodiment of stent segment 32 illustrated in Figs. 6A-6B is shown in a similarly expanded condition in Fig. 8. With stent segments 32 deployed, expandable member 24 may be retracted within sheath 25, again maintaining force against pusher tube 86 to position stent segments 32 at the distal end of expandable member 24. Expandable member 24 is moved proximally relative to stent segments 32 until the distal-most stent segment engages stop 78 (Figs 2A-2B), thereby placing stent segments 32 in position for deployment. Stent delivery catheter 20 is then ready to be repositioned at a different lesion in the same or different artery, and additional stent segments may be deployed. During such repositioning, guidewire tube 34 facilitates smooth tracking over guidewire GW. Advantageously, multiple lesions of various lengths may be treated in this way without removing stent delivery catheter 20 from the patient's body. Should there be a need to exchange stent delivery catheter 20 with other catheters to be introduced over guidewire GW, guidewire tube 34 facilitates quick and easy exchanges.

[0109] When the movement of the pusher tube, sheath, or stent segments is described in relation to other components of the delivery catheter of the invention, such movement is relative and will encompass both moving the sheath, pusher tube, or stent segments while keeping the other component(s) stationary, keeping the sheath, pusher tube or stent segments stationary while moving the other component(s), or moving multiple components simultaneously relative to each other.

[0110] While the foregoing description of the invention is directed to a stent delivery catheter for deploying stents into vascular lumens to maintain patency, various other types of

wire-guided catheters also may embody the principles of the invention. For example, balloon catheters for angioplasty and other purposes, particularly those having a slidable external sheath surrounding the balloon, may be constructed in accordance with the invention. Other types of catheters for deployment of prosthetic devices such as embolic coils, stent grafts, aneurism repair devices, annuloplasty rings, heart valves, anastomosis devices, staples or clips, as well as ultrasound and angiography catheters, electrophysiological mapping and ablation catheters, and other devices may also utilize the principles of the invention.

[0111] Although the above is complete description of the preferred embodiments of the invention, various alternatives, additions, modifications and improvements may be made without departing from the scope thereof, which is defined by the claims.

WHAT IS CLAIMED IS:

1. Apparatus for delivering a prosthesis into a target vessel comprising:
a flexible catheter shaft having proximal and distal ends and a first lumen therein;
a tubular prosthesis releasably carried near the distal end of the catheter shaft, the tubular prosthesis being expandable to a shape suitable for engaging the target vessel;
a sheath disposed over the catheter shaft and the tubular prosthesis and being axially movable relative thereto, the sheath having proximal and distal ends and an exit port between the proximal and distal ends; and
a guidewire tube extending through the exit port and having a distal extremity disposed within the sheath and a proximal extremity disposed outside of the sheath, the guidewire tube being adapted for slidably receiving a guidewire therethrough.
2. The apparatus of claim 1 wherein the guidewire tube is slidable through the exit port.
3. The apparatus of claim 1 wherein the exit port is fluidly sealed around the guidewire tube.
4. The apparatus of claim 1 wherein the guidewire tube is fixed relative to the catheter shaft.
5. The apparatus of claim 1 wherein the sheath has a proximal portion proximal to the exit port and a distal portion distal to the exit port, the proximal portion having a smaller outer diameter than the distal portion.
6. The apparatus of claim 1 wherein the exit port is oriented so as to face generally in a proximal direction.
7. The apparatus of claim 1 wherein the proximal extremity of the guidewire tube is about 3-15 cm in length.
8. The apparatus of claim 1 wherein the guidewire tube has a proximal end disposed a distance of less than about $\frac{1}{2}$ the length of the catheter shaft from the distal end thereof.

9. The apparatus of claim 1 wherein the tubular prosthesis is self-expanding.
10. The apparatus of claim 9 wherein the sheath constrains expansion of the tubular prosthesis and is retractable to allow the tubular prosthesis to expand.
11. The apparatus of claim 1 further comprising an expandable member mounted to the catheter shaft near the distal end thereof, the tubular prosthesis being positionable over the expandable member for expansion therewith.
12. The apparatus of claim 11 wherein the expandable member comprises a balloon having an interior, the inner lumen in the catheter shaft being in communication with the interior for delivery of inflation fluid thereto.
13. The apparatus of claim 12 wherein the guidewire tube extends through the interior of the balloon.
14. The apparatus of claim 11 wherein the sheath is axially positionable relative to the expandable member and configured to restrain expansion of a selected portion of the expandable member.
15. The apparatus of claim 14 wherein the sheath is reinforced to prevent expansion thereof by the expandable member.
16. The apparatus of claim 1 wherein the tubular prosthesis comprises a plurality of prosthesis segments.
17. The apparatus of claim 16 wherein the sheath is axially movable relative to the prosthesis segments and configured to restrain expansion of a selectable number of prosthesis segments.
18. The apparatus of claim 1 further comprising a pusher slidably disposed over the catheter shaft within the sheath, the pusher having a distal end in engagement with the tubular prosthesis for moving the tubular prosthesis relative to the catheter shaft or the sheath.

19. A method of delivering a prosthesis in a target vessel of a patient comprising:
- inserting a guidewire through the patient's vasculature to the target vessel;
 - slidably coupling a delivery catheter to the guidewire, the delivery catheter having a sheath and a guidewire tube, a proximal extremity of the guidewire tube being outside the sheath and a distal extremity of the guidewire tube being inside the sheath, the guidewire being slidably positioned through the guidewire tube;
 - advancing the delivery catheter over the guidewire to the target vessel;
 - retracting the sheath relative to the guidewire tube to expose a tubular prosthesis carried by the delivery catheter; and
 - expanding the tubular prosthesis into engagement with the target vessel.
20. The method of claim 19 wherein the guidewire tube extends through an exit port in a sidewall of the sheath and retracting the sheath comprises sliding the guidewire tube through the exit port.
21. The method of claim 20 further comprising sealing the exit port around the guidewire tube to restrict fluid flow therethrough.
22. The method of claim 19 wherein the delivery catheter further includes a catheter shaft, the sheath being slidably disposed over the catheter shaft, and wherein retracting the sheath comprises moving the sheath relative to the catheter shaft.
23. The method of claim 22 wherein the delivery catheter further comprises an expandable member fixed to the catheter shaft, the tubular prosthesis being positionable over the expandable member, and wherein expanding the tubular prosthesis comprises expanding the expandable member.
24. The method of claim 23 further comprising covering a proximal portion of the expandable member by the sheath to constrain the proximal portion from expansion while a distal portion of the expandable member expands.
25. The method of claim 23 wherein the expandable member is inflatable, further comprising delivering inflation fluid to the expandable member through an inflation lumen in the catheter shaft.

26. The method of claim 23 wherein the expandable member has an interior, the guidewire tube extending through the interior.

27. The method of claim 23 wherein the tubular prosthesis comprises a plurality of prosthesis segments, further comprising positioning a first selected number of the prosthesis segments on the expandable member for expansion therewith.

28. The method of claim 27 further comprising positioning the sheath over a second selected number of the prosthesis segments to constrain expansion thereof.

29. The method of claim 27 wherein the delivery catheter further comprises a pusher slidably disposed within the sheath, and wherein positioning the first selected number of prosthesis segments comprises pushing the first selected number with the pusher.

30. The method of claim 19 wherein the tubular prosthesis self-expands when the sheath is retracted.

31. The method of claim 19 wherein the proximal extremity of the guidewire tube has a proximal end disposed a distance of less than about $\frac{1}{2}$ the length of the sheath from a distal end thereof, the guidewire extending out of the proximal end.

32. The method of claim 20 wherein the exit port is oriented to face in a generally proximal direction such that guidewire tube slides axially through the exit port.

33. A balloon catheter for treating a target vessel comprising:
a flexible catheter shaft having proximal and distal ends and a first lumen therein;
an expandable member connected to the catheter shaft;
a sheath disposed over the catheter shaft and the expandable member and being axially movable relative thereto, the sheath having proximal and distal ends and an exit port between the proximal and distal ends; and
a guidewire tube extending through the exit port and having a distal extremity disposed within the sheath and a proximal extremity disposed outside of the sheath, the guidewire tube being adapted for slidably receiving a guidewire therethrough.

34. The apparatus of claim 33 wherein the guidewire tube is slidable through the exit port.
35. The apparatus of claim 33 wherein the exit port is fluidly sealed around the guidewire tube.
36. The apparatus of claim 33 wherein the guidewire tube is fixed relative to the catheter shaft.
37. The apparatus of claim 33 wherein the sheath has a proximal portion proximal to the exit port and a distal portion distal to the exit port, the proximal portion having a smaller outer diameter than the distal portion.
38. The apparatus of claim 33 wherein the exit port is oriented so as to face generally in a proximal direction.
39. The apparatus of claim 33 wherein the proximal extremity of the guidewire tube is about 3-15 cm in length.
40. The apparatus of claim 33 wherein the guidewire tube has a proximal end disposed a distance of less than about $\frac{1}{2}$ the length of the catheter shaft from the distal end thereof.
41. The apparatus of claim 33 further comprising a tubular prosthesis disposed on the expandable member.
42. The apparatus of claim 41 wherein the tubular prosthesis comprises a plurality of unconnected stent segments.
43. The apparatus of claim 42 wherein the stent segments are slidable relative to the expandable member.
44. The apparatus of claim 42 wherein the sheath is positionable to expose a first selected portion of the stent segments while covering a second selected portion of the stent segments.

45. The apparatus of claim 33 wherein the expandable member comprises a balloon, the balloon being in fluid communication with the first lumen to receive inflation fluid therefrom.

46. The apparatus of claim 33 wherein the sheath is positionable to constrain a first selected portion of the expandable member from expansion while a second selected portion of the expandable member expands.

47. Apparatus for delivering a prosthesis into a target vessel comprising:
a flexible catheter shaft having proximal and distal ends;
a tubular prosthesis slidably coupled to the catheter shaft, the tubular prosthesis being expandable to a shape suitable for engaging the target vessel;
a pusher for moving the tubular prosthesis from a pre-deployment position to a deployment position near the distal end of the catheter shaft; and
a stop on the catheter shaft configured to engage the tubular prosthesis when the tubular prosthesis is in the deployment position.

48. The apparatus of claim 47 further comprising an expandable member coupled to the catheter shaft, the deployment position being on the expandable member, the tubular prosthesis being adapted for expansion by the expandable member.

49. Apparatus of claim 48 wherein expandable member has an interior, the stop being disposed within the interior of the expandable member.

50. Apparatus of claim 47 further comprising a plurality of tubular prostheses slidably coupled to the catheter shaft and being movable by the pusher to the deployment position.

51. Apparatus of claim 47 further comprising a sheath movably coupled to the catheter shaft and positionable over the tubular prosthesis.

52. A method of deploying a tubular prosthesis in a target vessel, the method comprising:
positioning a catheter shaft in the target vessel;

moving the tubular prosthesis distally relative to the catheter shaft while the catheter shaft remains in the target vessel until the prosthesis engages a stop near the distal end of the catheter shaft; and

expanding the tubular prosthesis to engage a wall of the target vessel.

53. The method of claim 52 further comprising, after expanding the tubular prosthesis, moving a second prosthesis distally relative to the catheter shaft until the second prosthesis engages the stop, and expanding the second prosthesis to engage a wall of the target vessel.

54. The method of claim 52 further comprising moving a second prosthesis distally relative to the catheter shaft simultaneously with moving the tubular prosthesis, and expanding the second prosthesis and the tubular prosthesis together to engage the wall of the target vessel.

55. The method of claim 52 further comprising retaining a second prosthesis in an unexpanded configuration on the catheter shaft while the tubular prosthesis is expanded.

56. The method of claim 55 wherein the second prosthesis is retained within a sheath movably coupled to the catheter shaft.

57. The method of claim 52 wherein the tubular prosthesis is expanded by inflating a balloon coupled to the catheter shaft.

58. The method of claim 52 wherein the tubular prosthesis is moved by a pusher movably coupled to the catheter shaft.

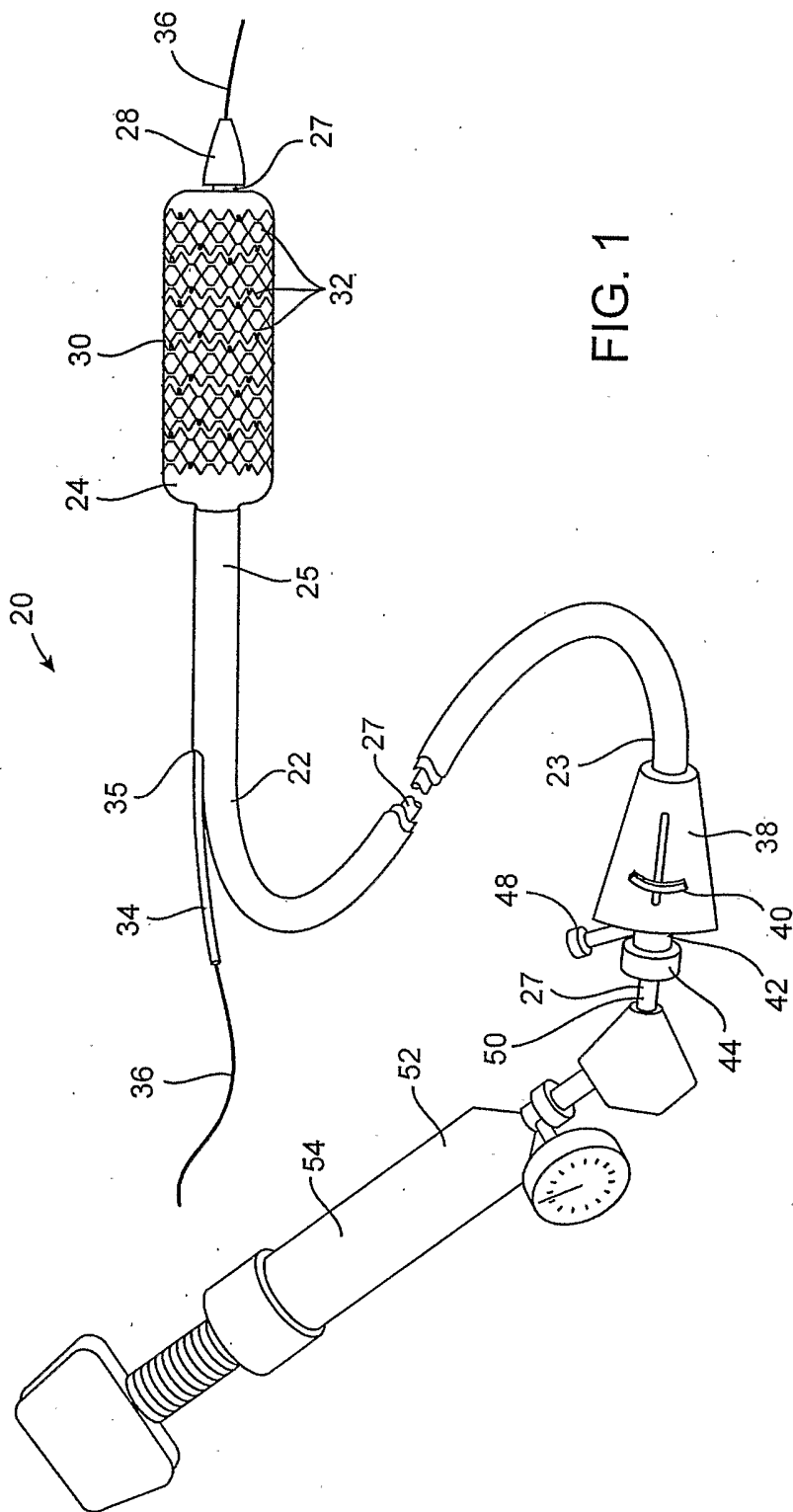

FIG. 1

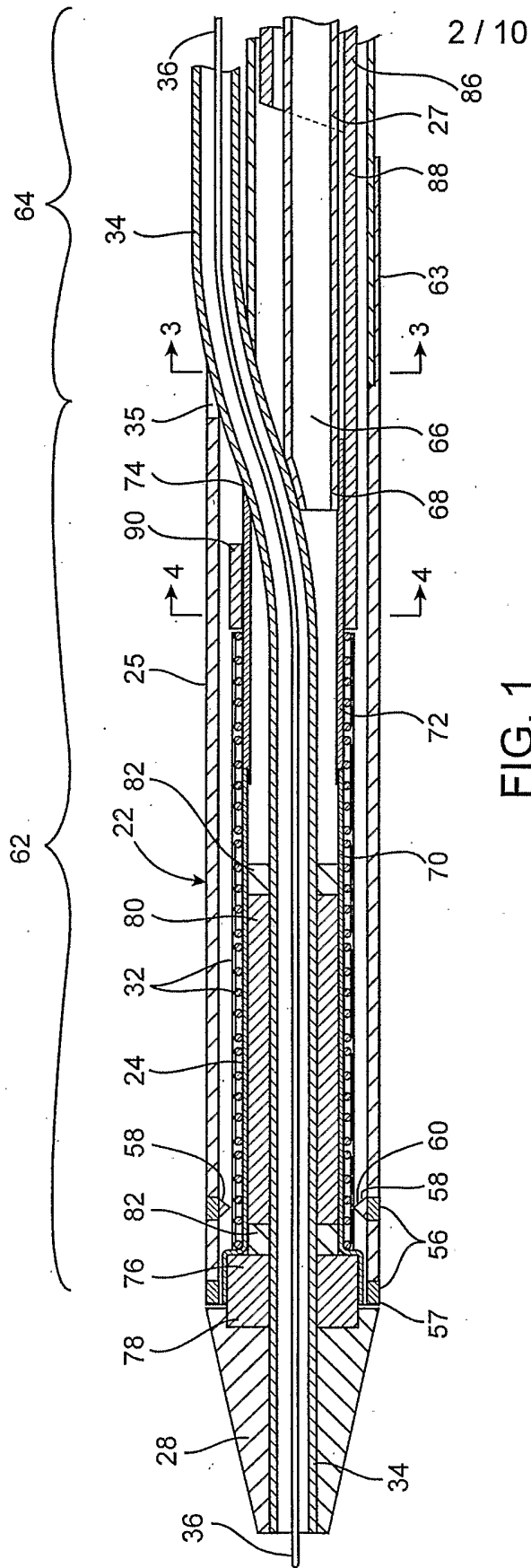

FIG. 1

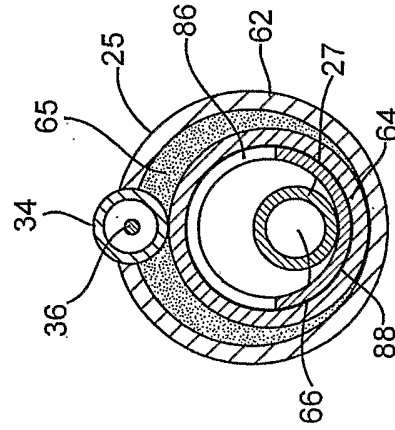

FIG. 3

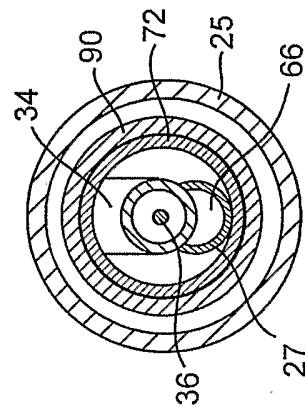

FIG. 4

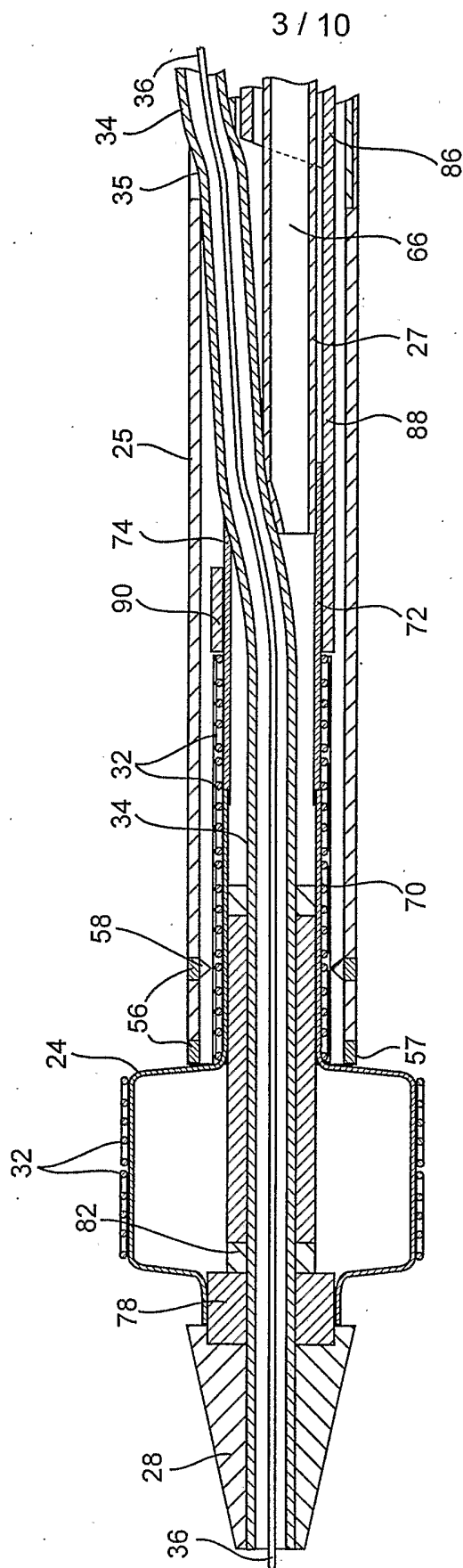

FIG. 2B

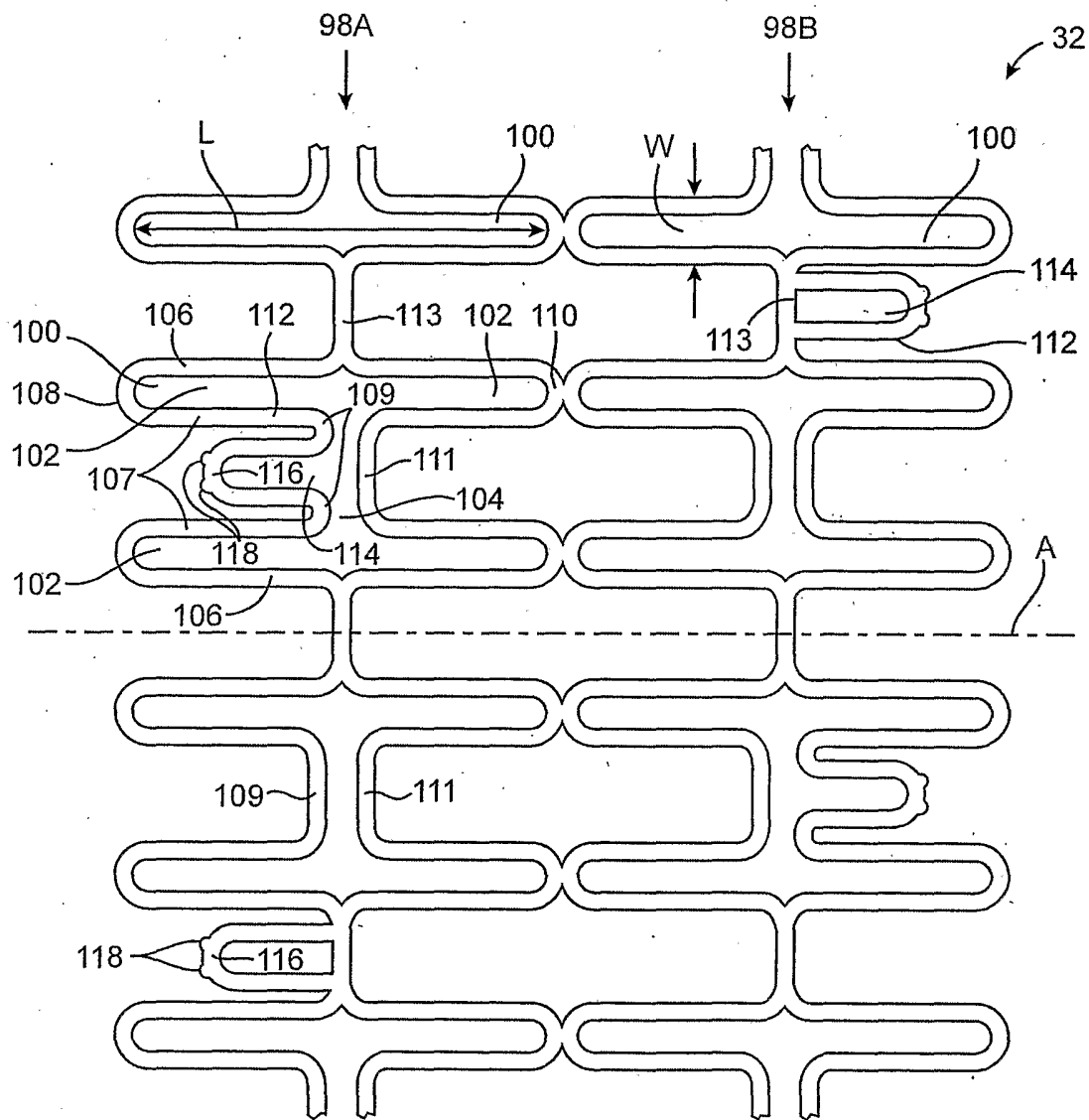

FIG. 5A

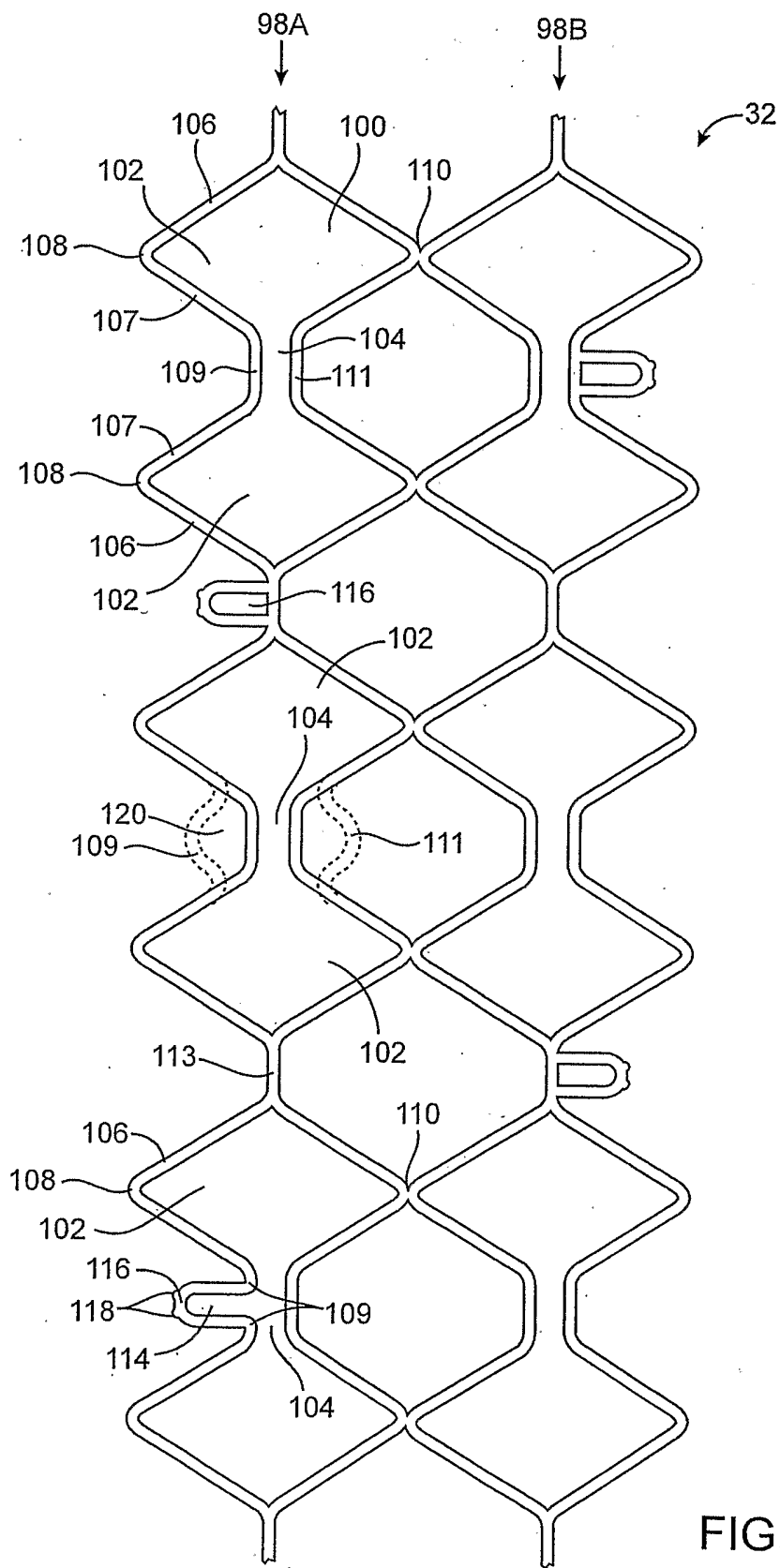

FIG. 5B.

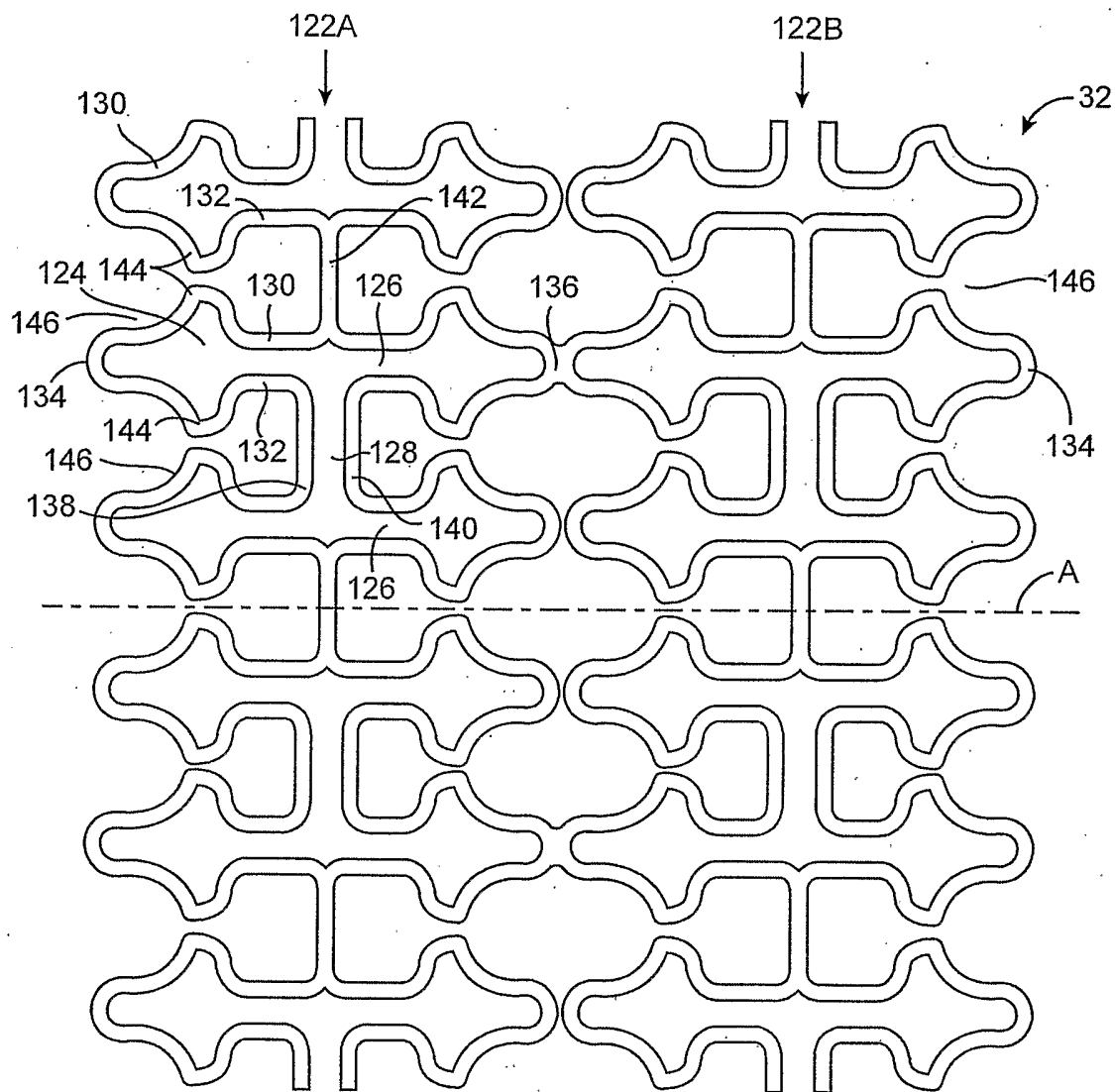

FIG. 6A

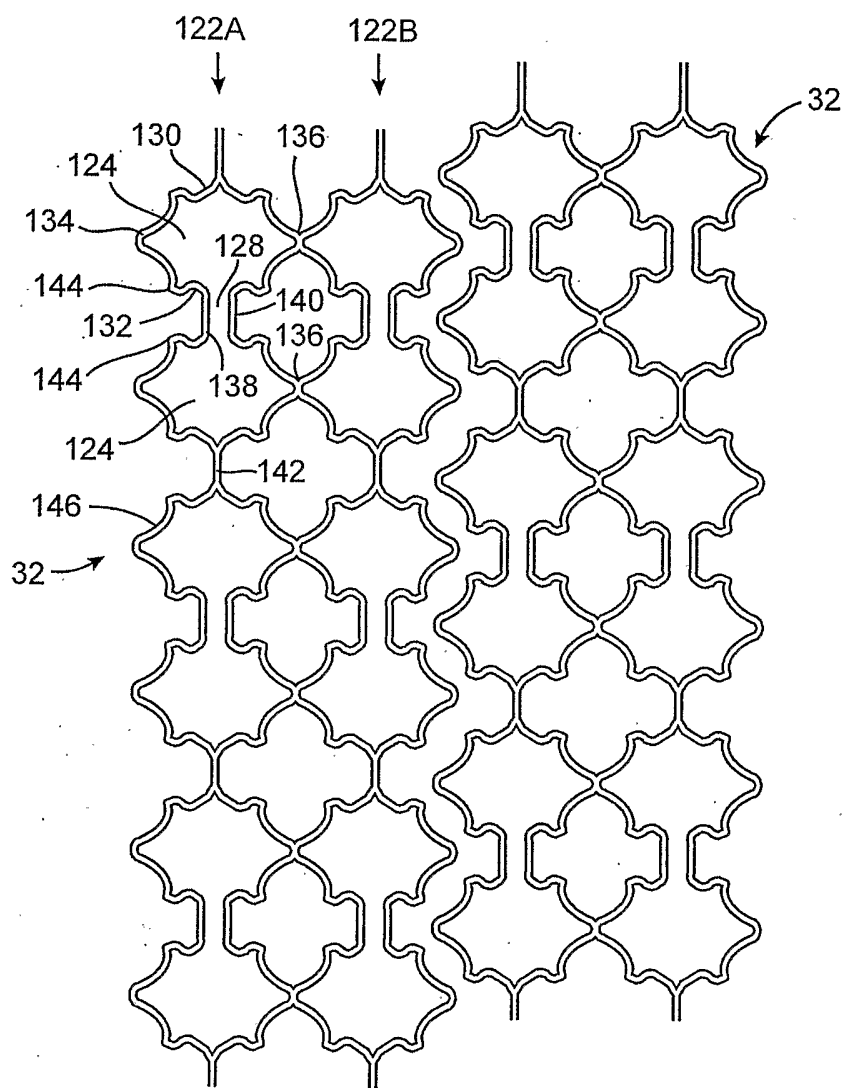

FIG. 6B

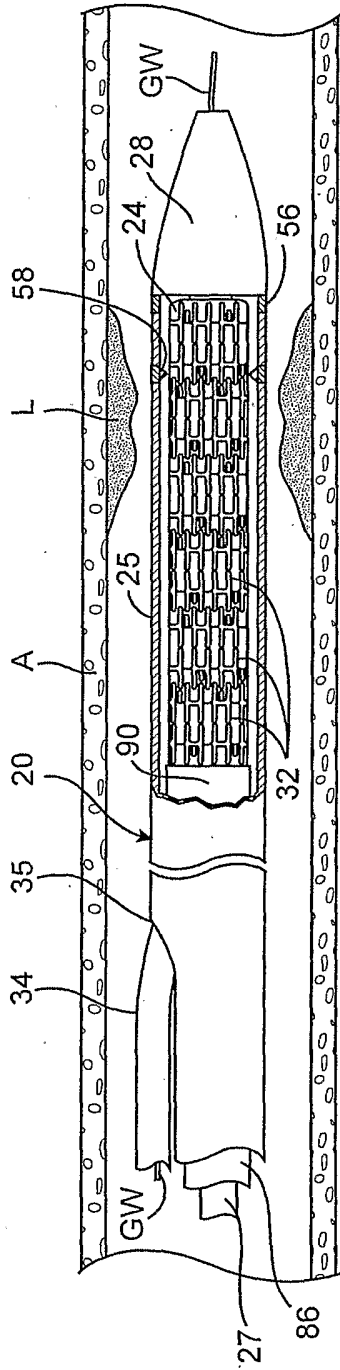

FIG. 7A

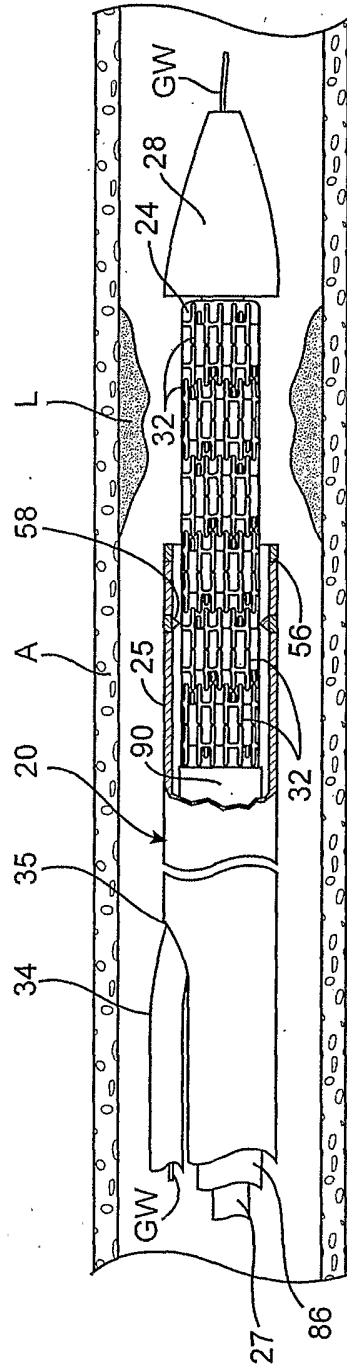

FIG. 7B

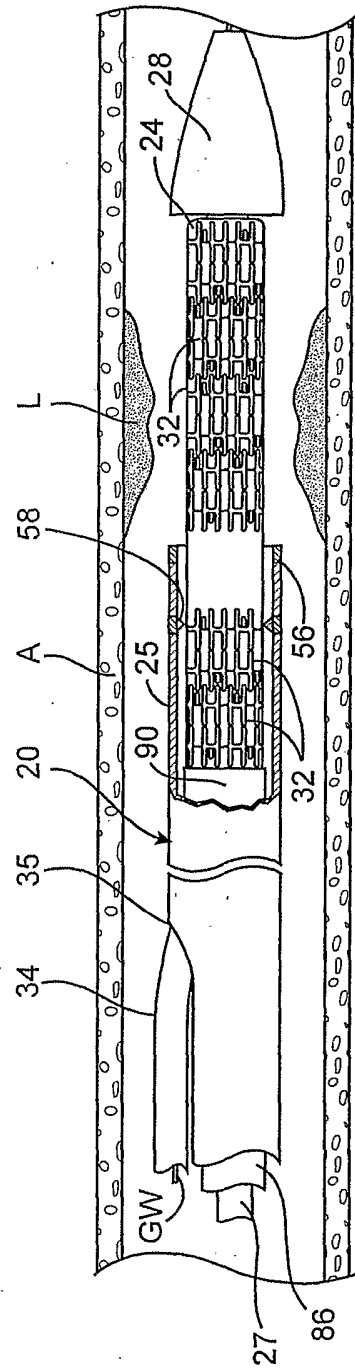

FIG. 7C

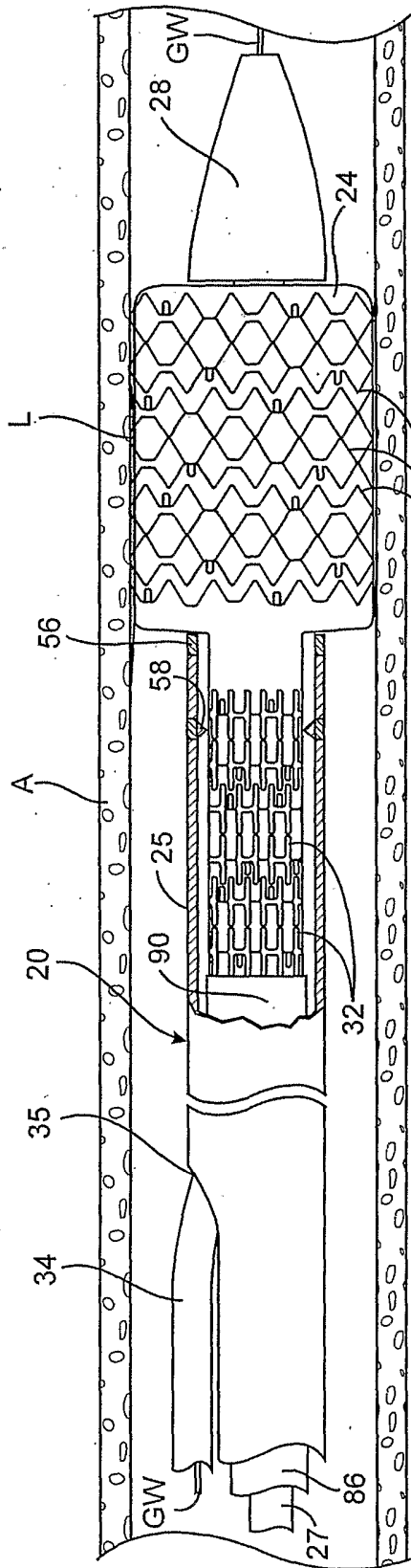

FIG. 7D

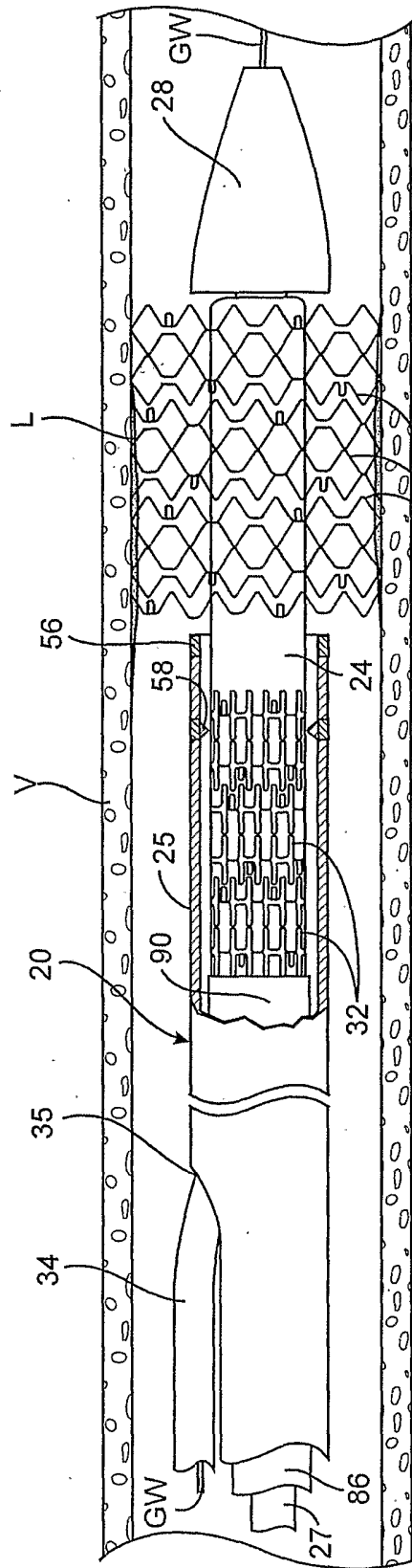

FIG. 7E

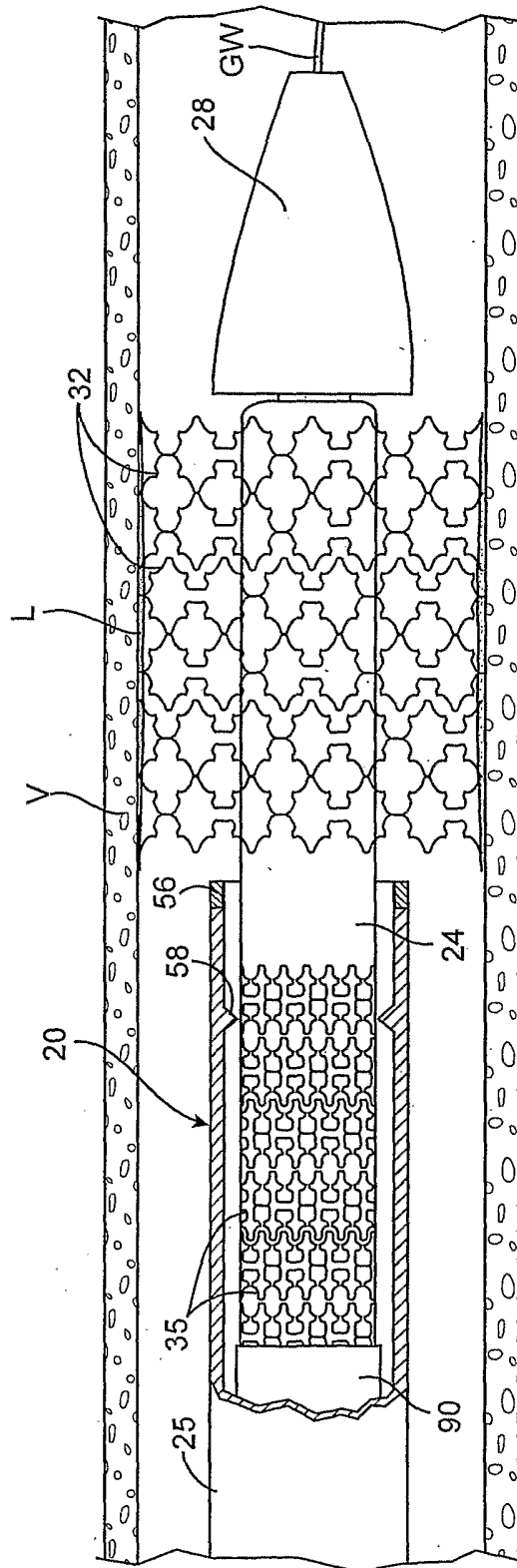

FIG. 8