



US 20140221454A1

(19) **United States**

(12) **Patent Application Publication**  
**Brown**

(10) **Pub. No.: US 2014/0221454 A1**

(43) **Pub. Date: Aug. 7, 2014**

(54) **EXTENDED DICER SUBSTRATE AGENTS  
AND METHODS FOR THE SPECIFIC  
INHIBITION OF GENE EXPRESSION**

Apr. 28, 2009, provisional application No. 61/173,556,  
filed on Apr. 28, 2009, provisional application No.  
61/173,558, filed on Apr. 28, 2009, provisional appli-  
cation No. 61/173,563, filed on Apr. 28, 2009.

(71) Applicant: **Dicerna Pharmaceuticals, Inc.,**  
Watertown, MA (US)

**Publication Classification**

(72) Inventor: **Bob Dale Brown,** Millington, NJ (US)

(51) **Int. Cl.**  
**C12N 15/113** (2006.01)

(73) Assignee: **Dicerna Pharmaceuticals, Inc.,**  
Watertown, MA (US)

(52) **U.S. Cl.**  
CPC ..... **C12N 15/113** (2013.01)  
USPC ..... **514/44 A; 536/24.5; 435/375; 536/25.3;**  
435/91.5

(21) Appl. No.: **13/971,507**

(22) Filed: **Aug. 20, 2013**

(57) **ABSTRACT**

**Related U.S. Application Data**

(63) Continuation of application No. 12/642,371, filed on  
Dec. 18, 2009, now Pat. No. 8,513,207.

(60) Provisional application No. 61/138,946, filed on Dec.  
18, 2008, provisional application No. 61/166,227,  
filed on Apr. 2, 2009, provisional application No.  
61/173,505, filed on Apr. 28, 2009, provisional appli-  
cation No. 61/173,514, filed on Apr. 28, 2009, provi-  
sional application No. 61/173,521, filed on Apr. 28,  
2009, provisional application No. 61/173,525, filed on  
Apr. 28, 2009, provisional application No. 61/173,532,  
filed on Apr. 28, 2009, provisional application No.  
61/173,538, filed on Apr. 28, 2009, provisional appli-  
cation No. 61/173,544, filed on Apr. 28, 2009, provi-  
sional application No. 61/173,549, filed on Apr. 28,  
2009, provisional application No. 61/173,554, filed on

The invention provides compositions and methods for reduc-  
ing expression of a target gene in a cell, involving contacting  
a cell with an isolated double stranded nucleic acid (dsNA) in  
an amount effective to reduce expression of a target gene in a  
cell. The dsNAs of the invention possess a pattern of deox-  
yribonucleotides (in most embodiments, the pattern com-  
prises at least one deoxyribonucleotide-deoxyribonucleotide  
base pair) designed to direct the site of Dicer enzyme cleavage  
within the dsNA molecule. Deoxyribonucleotides of the  
dsNA molecules of the invention are located within a region  
of the dsNA that can be excised via Dicer cleavage to generate  
an active siRNA agent that no longer contains the deoxyribo-  
nucleotide pattern (e.g., deoxyribonucleotide-deoxyribo-  
nucleotide base pairs). Such DNA-extended Dicer-substrate  
siRNAs (DsiRNAs) were demonstrated to be more effective  
RNA inhibitory agents than corresponding double stranded  
RNA-extended DsiRNAs. DsiRNA agents were also found to  
tolerate guide strand mismatches.

FIGURE 1

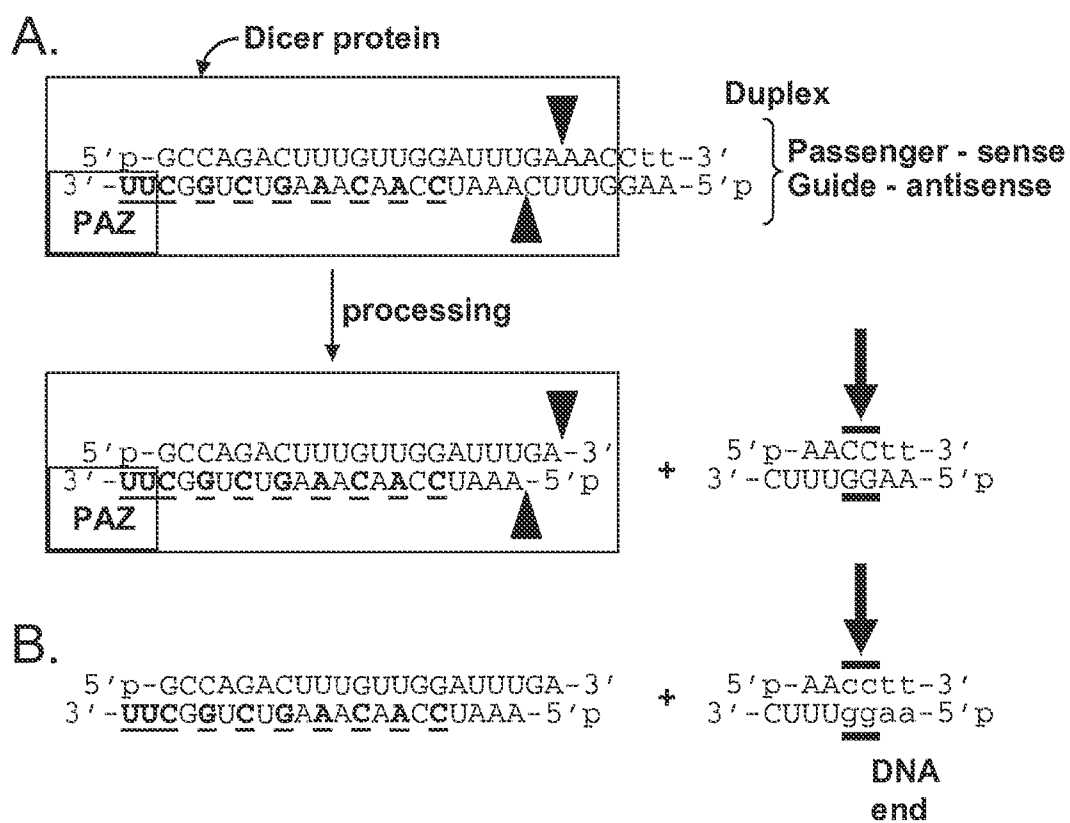
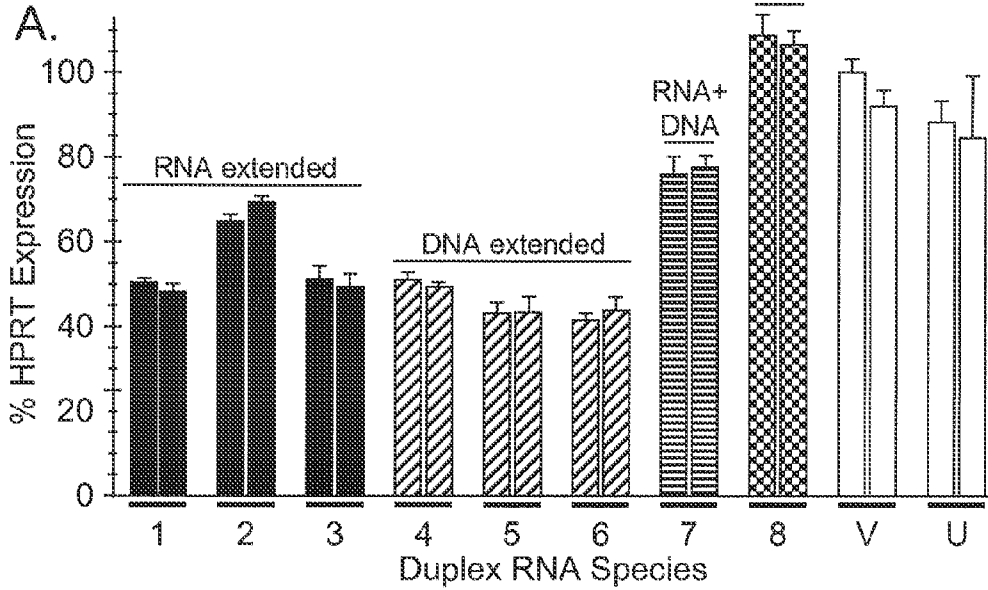

FIGURE 2.



B.

Duplex	Sequence and modifications	Description	Lengths
1	5'p-GCCAGACUUUGUUGGAUUUGAAAtt-3' 3'-UUCGGUCUGAAACAACC UAAACUUUAA-5'p	25/27 standard	25/27mer
2	5'p-GCCAGACUUUGUUGGAUUUGAAACctt-3' 3'-UUCGGUCUGAAACAACC UAAACUUUGGAA-5'p	RNA insert/DNA	27/29mer
3	5'p-GCCAGACUUUGUUGGAUUUGAAACCAACAtt-3' 3'-UUCGGUCUGAAACAACC UAAACUUUGGUUGUAA-5'p	RNA insert/DNA	31/33mer
4	5'p-GCCAGACUUUGUUGGAUUUGAAAacctt-3' 3'-UUCGGUCUGAAACAACC UAAACUUUggaa-5'p	DNA 4 bp	27/29mer
5	5'p-GCCAGACUUUGUUGGAUUUGAAAccaacatt-3' 3'-UUCGGUCUGAAACAACC UAAACUUUggttgtaa-5'p	DNA 8 bp	31/33mer
6	5'p-GCCAGACUUUGUUGGAUUUGAAAccaacagctt-3' 3'-UUCGGUCUGAAACAACC UAAACUUUggttgtagaa-5'p	DNA 10 bp	33/35mer
7	5'p-GCCAGACUUUGUUGGAUUUGAAAccAACAGctt-3' 3'-UUCGGUCUGAAACAACC UAAACUUUGGUUGUCGAA-5'p	DNA/RNA	33/35mer
8	5'p-GCCAGACUUUGUUGGAUUUGAAAccaacagctt-3' 3'-UUCGGUCUGAAACAACC UAAACUUUggttgtagaa-5'p	PS-DNA 10 bp	33/35mer

FIGURE 3. Dose-response comparison of duplexes

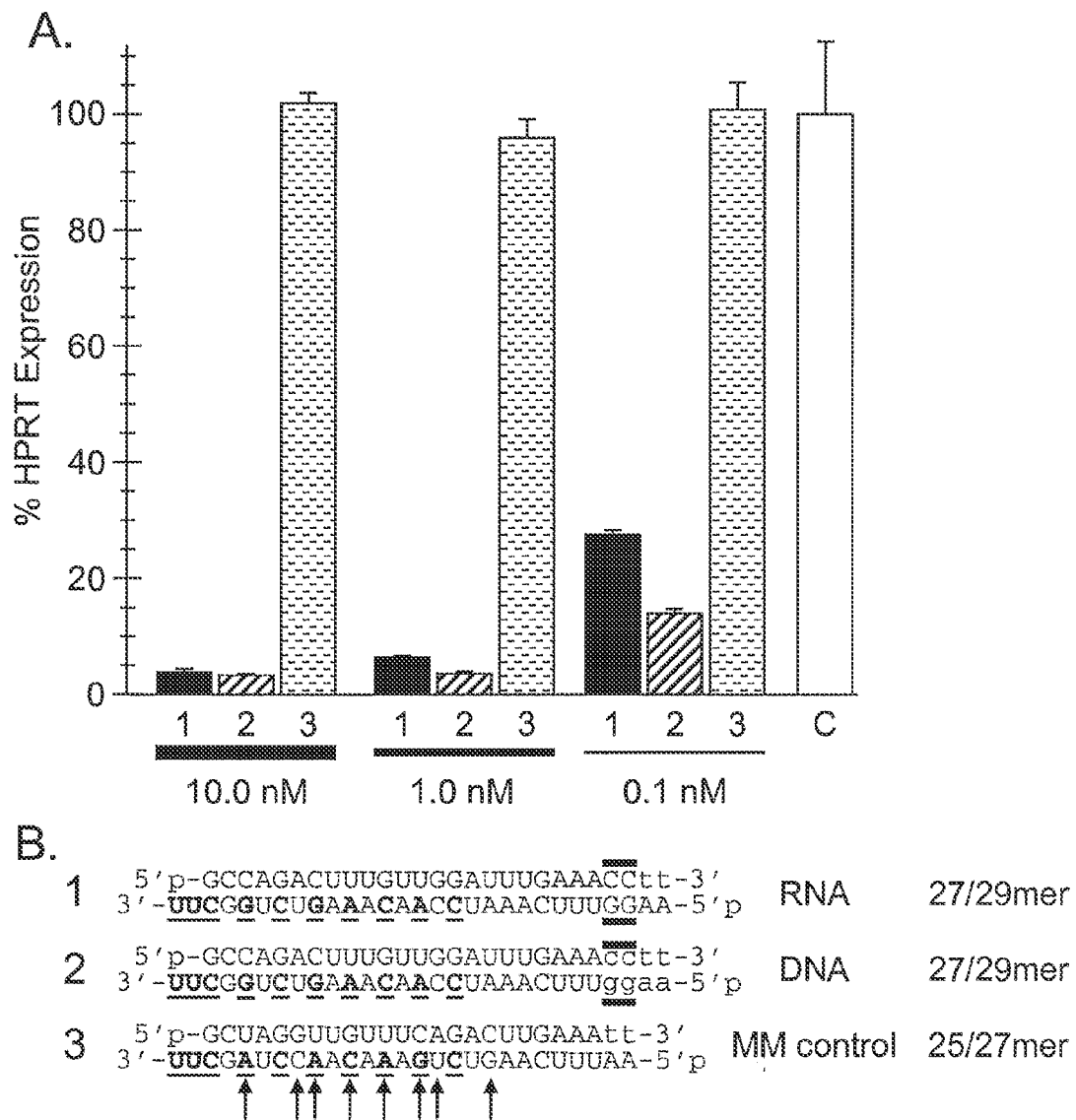
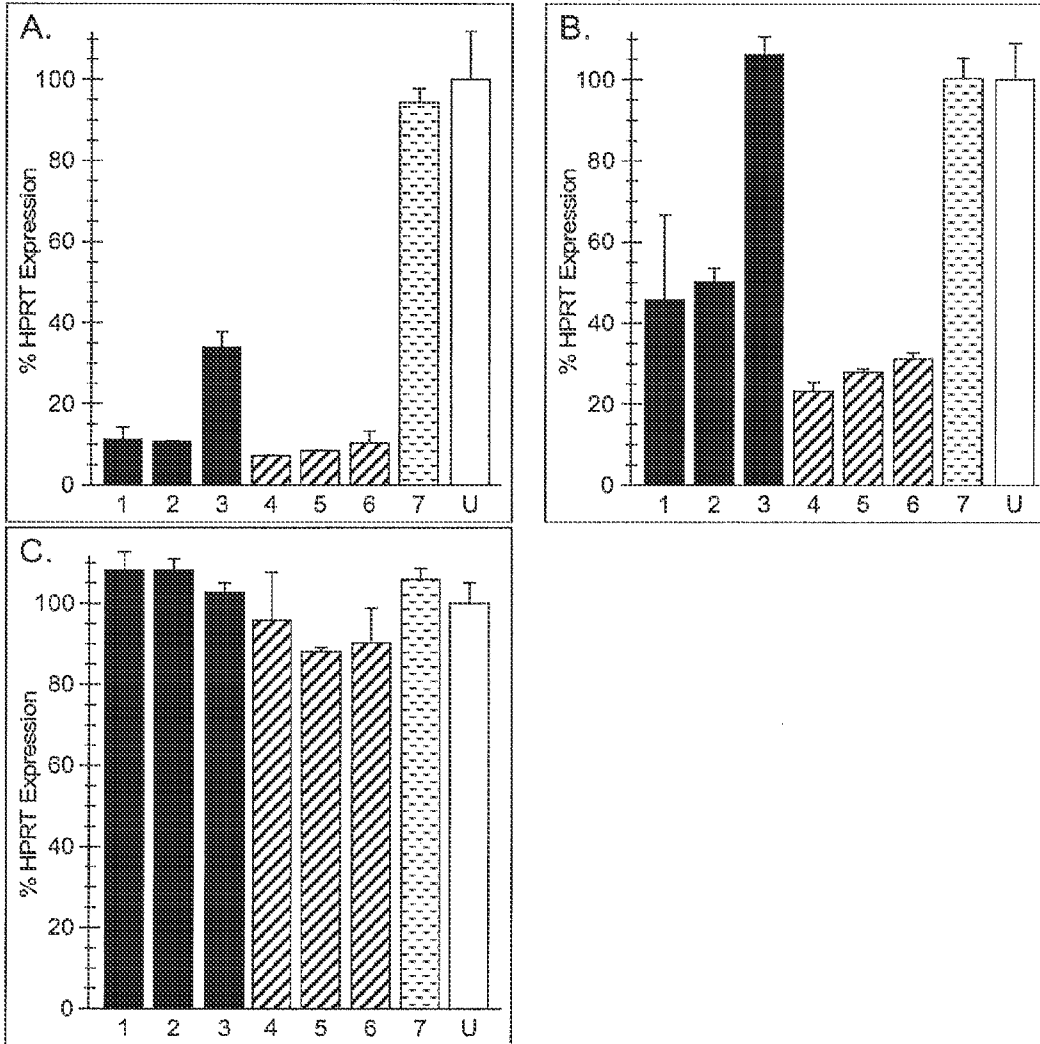



FIGURE 4. Comparison of duplexes extended by 2, 6, and 8 bases.



D.

1	5'p-GCCAGACUUUGUUGGAUUUGAAACcctt-3' 3'- <u>UUCGGUCUGAAACAACC</u> UAAACUUUGGAA-5'p	RNA insert/DNA	27/29mer
2	5'p-AGCCAGACUUUGUUGGAUUUGAAACCAACAtt-3' 3'- <u>UUCGGUCUGAAACAACC</u> UAAACUUUGGUUGUAA-5'p	RNA insert/DNA	31/33mer
3	5'p-GCCAGACUUUGUUGGAUUUGAAAccAACAGcctt-3' 3'- <u>UUCGGUCUGAAACAACC</u> UAAACUUUGGUUGUCGAA-5'p	RNA 6 bp (+ 2 DNA)	33/35mer
4	5'p- GCCAGACUUUGUUGGAUUUGAAAcctt-3' 3'- <u>UUCGGUCUGAAACAACC</u> UAAACUUUGgaa-5'p	DNA 4 bp	27/29mer
5	5'p-GCCAGACUUUGUUGGAUUUGAAAccaacatt-3' 3'- <u>UUCGGUCUGAAACAACC</u> UAAACUUUGggttgtaa-5'p	DNA 8 bp	31/33mer
6	5'p- GCCAGACUUUGUUGGAUUUGAAAccaacagcctt-3' 3'- <u>UUCGGUCUGAAACAACC</u> UAAACUUUGggttgtaa-5'p	DNA 10 bp	33/35mer
7	5'p-GCUAGGUUGUUUCAGACUUUGAAAtt-3' 3'- <u>UUCGAUCCAACAAGUCUGAACUUUAA</u> -5'p	MM control	25/27mer

↑ ↑ ↑ ↑ ↑ ↑ ↑

FIGURE 5.

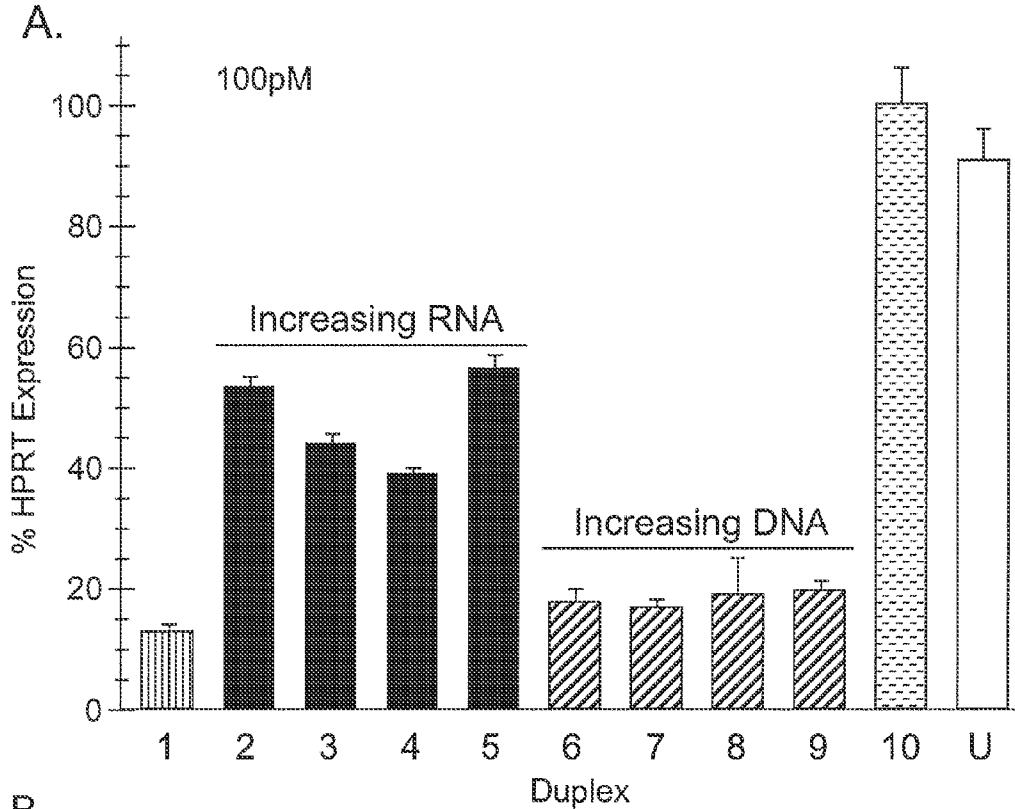

**B.**

Duplex	5' Sequence	3' Sequence	Category	Ratio
1	5'-p-GCCAGACUUUGUUGGAUUUGAAAtt-3'	3'- <u>UUCGGUCUGAAACAACC</u> UAAACUUUAA-5'p	Optimized	25/27
2	5'-p-GCCAGACUUUGUUGGAUUUGAAACctt-3'	3'- <u>UUCGGUCUGAAACAACC</u> UAAACUUUGGAA-5'p	RNA	27/29
3	5'-p-GCCAGACUUUGUUGGAUUUGAAACCAAtt-3'	3'- <u>UUCGGUCUGAAACAACC</u> UAAACUUUGGUAA-5'p	RNA	29/31
4	5'-p-GCCAGACUUUGUUGGAUUUGAAACCAACAtt-3'	3'- <u>UUCGGUCUGAAACAACC</u> UAAACUUUGGUUGAA-5'p	RNA	31/33
5	5'-p-GCCAGACUUUGUUGGAUUUGAAACCAACAGctt-3'	3'- <u>UUCGGUCUGAAACAACC</u> UAAACUUUGGUUGCGAA-5'p	RNA	33/35
6	5'-p-GCCAGACUUUGUUGGAUUUGAAAcctt-3'	3'- <u>UUCGGUCUGAAACAACC</u> UAAACUUUggaa-5'p	DNA	27/29
7	5'-p-GCCAGACUUUGUUGGAUUUGAAAccaatt-3'	3'- <u>UUCGGUCUGAAACAACC</u> UAAACUUUggttaa-5'p	DNA	29/31
8	5'-p-GCCAGACUUUGUUGGAUUUGAAAccaacatt-3'	3'- <u>UUCGGUCUGAAACAACC</u> UAAACUUUggttgtaa-5'p	DNA	31/33
9	5'-p-GCCAGACUUUGUUGGAUUUGAAAccaacagctt-3'	3'- <u>UUCGGUCUGAAACAACC</u> UAAACUUUggttgtagaa-5'p	DNA	33/35
10	5'-p-GCUAGGUUGUUUCAGACUUGAAAtt-3'	3'- <u>UUCGAUCCAACAAGUCUGAACUUUAA</u> -5'p	MM control	25/27

↑ ↑ ↑ ↑ ↑ ↑

Figure 6

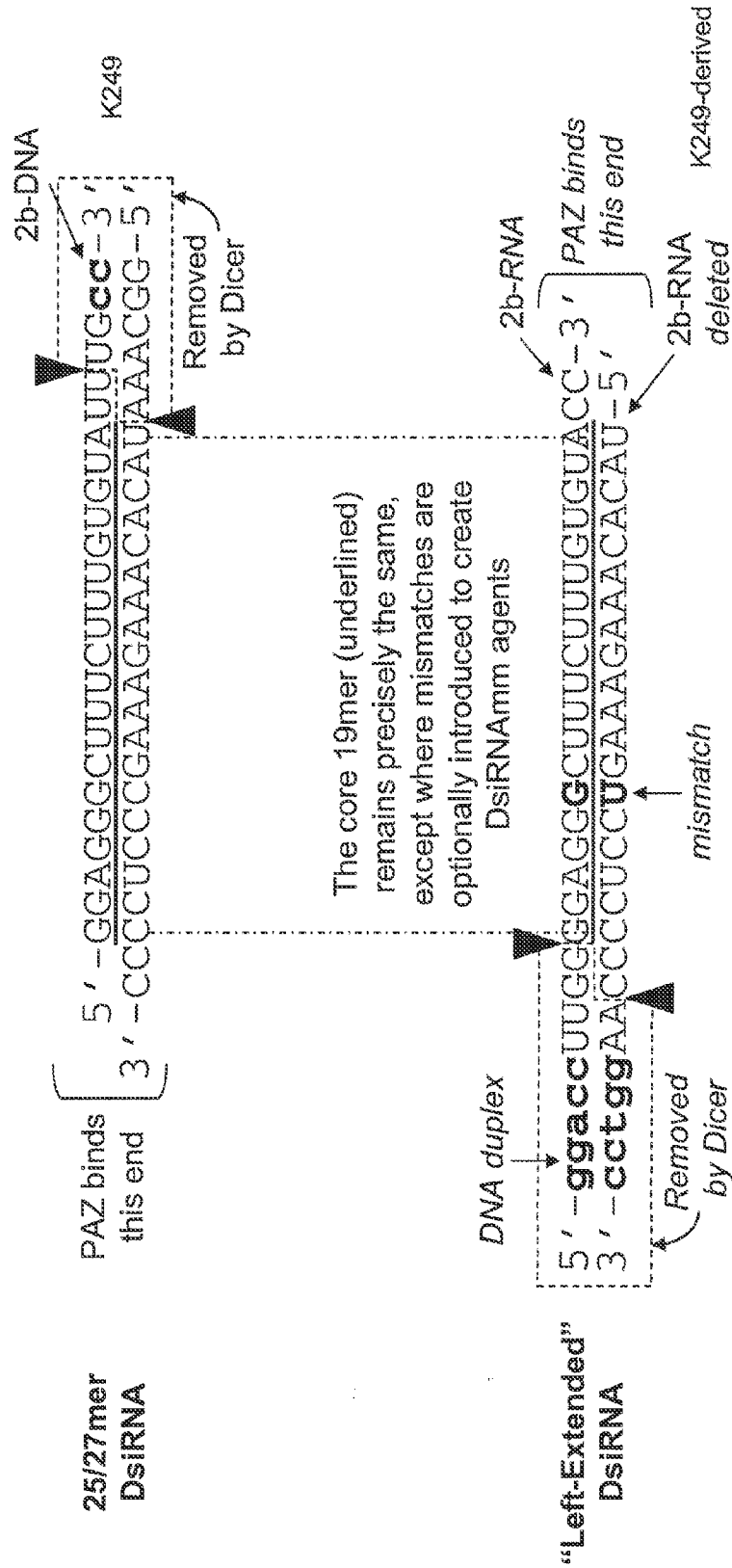

Figure 7

28/30mer Duplexes derived from KRAS-249

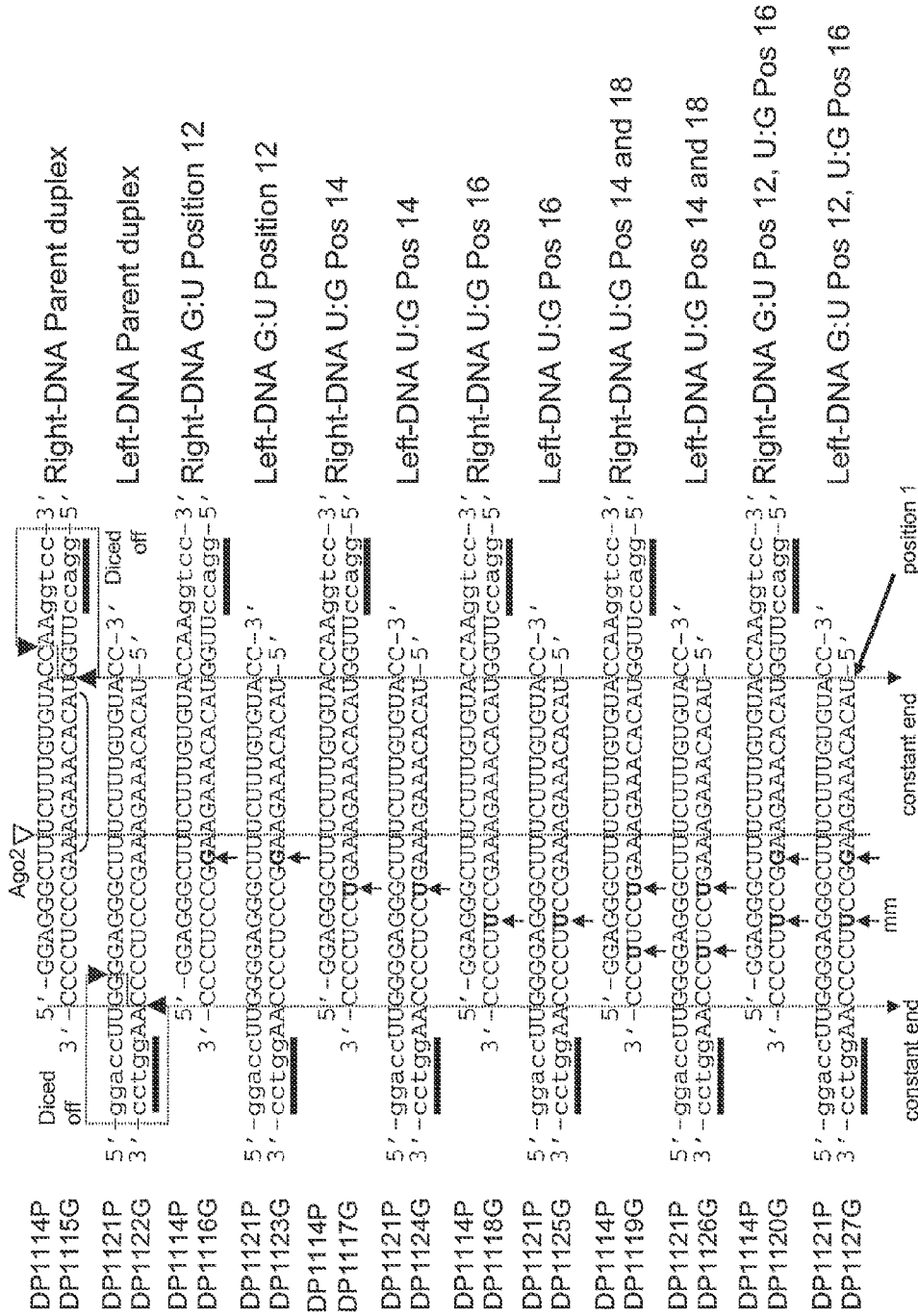
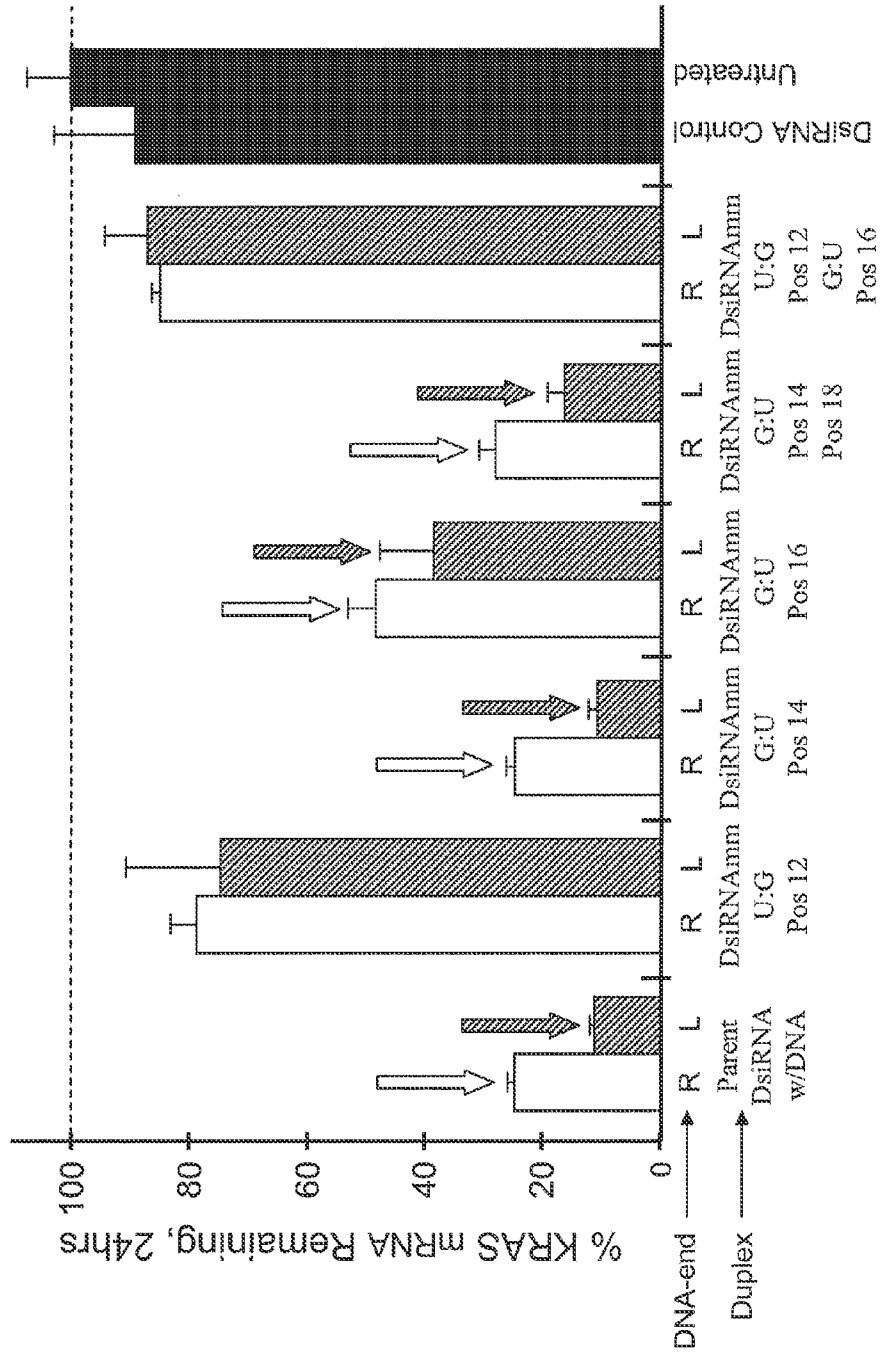

Figure 8



K249-derived

100 pM of each Duplex transfected into HeLa cells

Figure 9

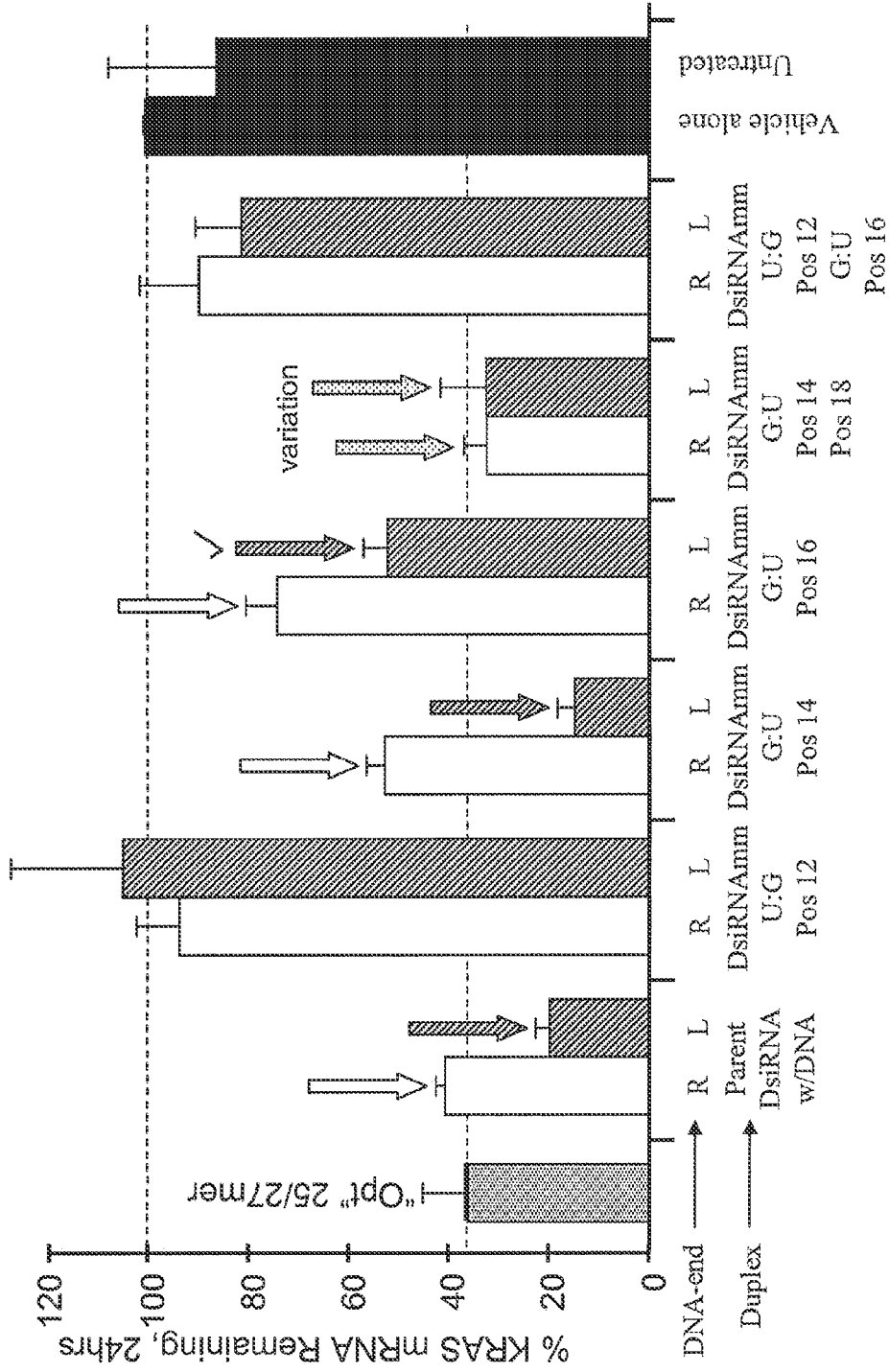

100 pM of each Duplex transfected into HeLa cells

K249-derived

**Figure 10**

HPRTcc	5' -> 3' sequence	Projected Dicer cleavage site	OPTIMIZED	% Reduction qPCR
DP1001P	5' - GCCAGACUUUGUUGGAUUUGAAATT-3'	▲	OPTIMIZED	89
DP1002G	3' - UUCCGUCUGAACACAAACUUA-5'	▲		
DP1030P	5' - GCCAGACUUUGUUGGAUUUGAACCTT-3'		DNA 4bp	77
DP1031G	3' - UUCCGUCUGAACACAAACUUGGAA-5'			
DP1032P	5' - GCCAGACUUUGUUGGAUUUGAACCAATT-3'		DNA 6bp	82
DP1033G	3' - UUCCGUCUGAACACAAACUUGGTTAA-5'			
DP1055P	5' - GCCAGACUUUGUUGGAUUUGAAATT-3'		DNA 4bp	80
DP1056G	3' - UUCCGUCUGAACACAAACUUA-5'			
DP1055P	5' - GCCAGACUUUGUUGGAUUUGAAATT-3'		DNA 4bp+2b	79
DP1057G	3' - UUCCGUCUGAACACAAACUUA-5'			
DP1058P	5' - GCCAGACUUUGUUGGAUUUGAACCTT-3'		DNA 6bp	80
DP1059G	3' - UUCCGUCUGAACACAAACUUA-5'			
DP1058P	5' - GCCAGACUUUGUUGGAUUUGAACCTT-3'		DNA 6bp+2b	76
DP1060G	3' - UUCCGUCUGAACACAAACUUA-5'			
DP1061P	5' - GCCAGACUUUGUUGGAUUUGAACCTT-3'		DNA 6bp(2PS)	74
DP1062G	3' - UUCCGUCUGAACACAAACUUA-5'			
DP1063P	5' - GCCAGACUUUGUUGGAUUUGAACCTT-3'		DNA 6bp(4PS)	74
DP1064G	3' - UUCCGUCUGAACACAAACUUA-5'			
DP1065P	5' - aggcaggtUUAAAGCCAGACUUUGUUGGAUUUGA-3'		Flip DNA 8bp	78
DP1066G	3' - tccgtccaaAUCCGUCUGAACACAAACUUA-5'			
DP1065P	5' - aggcaggtUUAAAGCCAGACUUUGUUGGAUUUGA-3'		Flip DNA 8bp	66
DP1067G	3' - tccgtccaaAUCCGUCUGAACACAAACUUA-5'	▲		

HPRT Targeting DsiRNAs

Figure 11

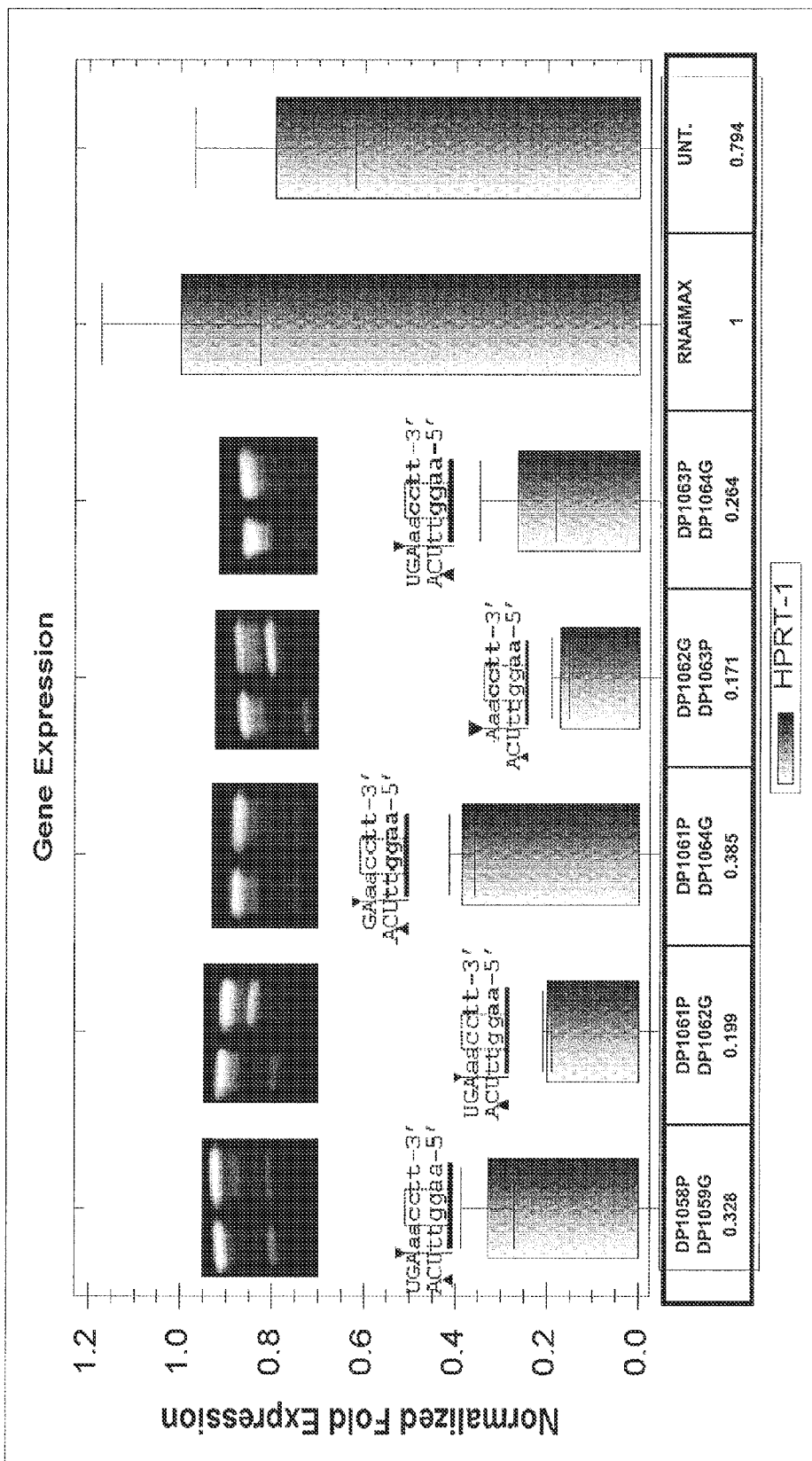



Figure 12

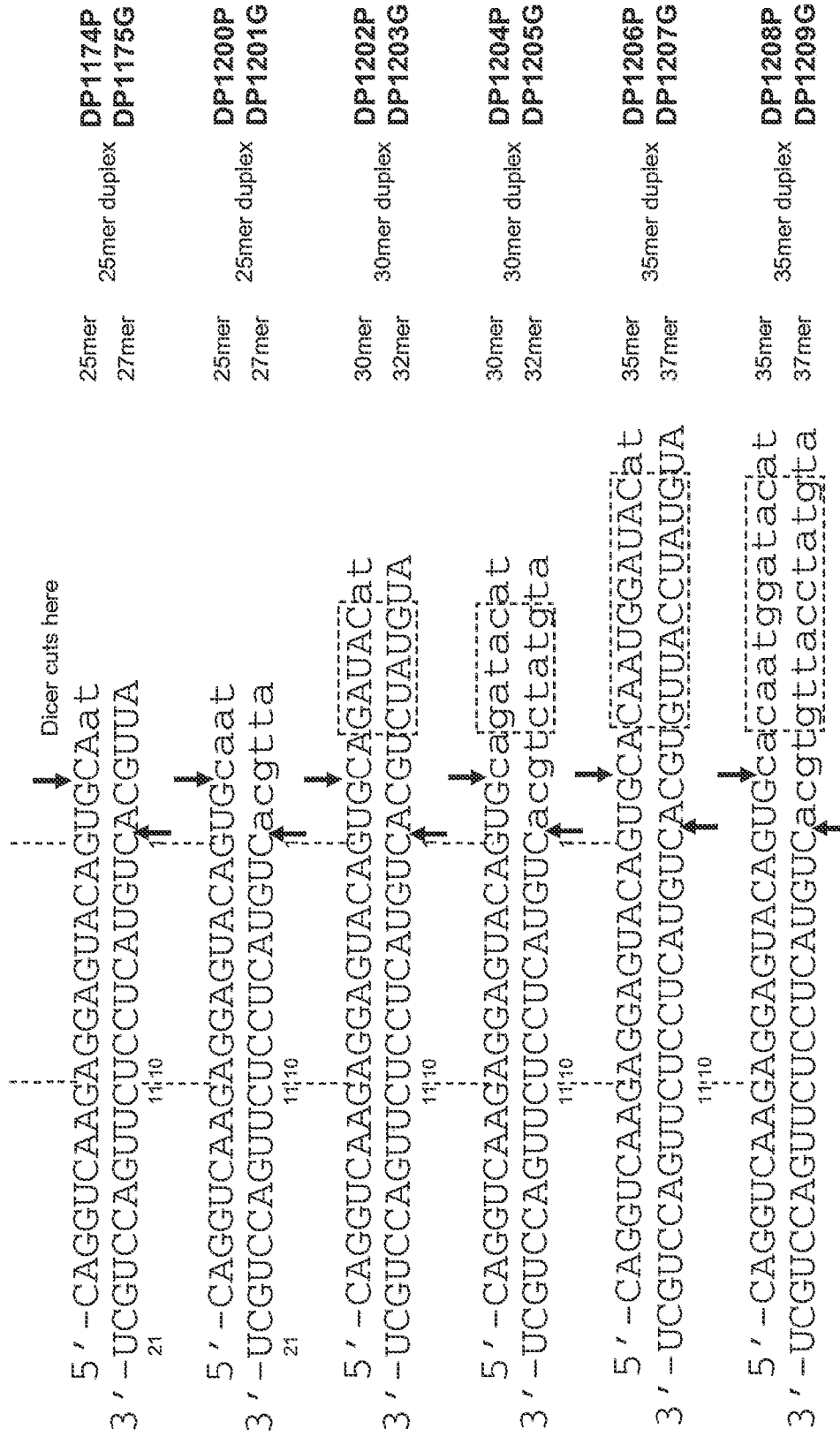

Figure 13

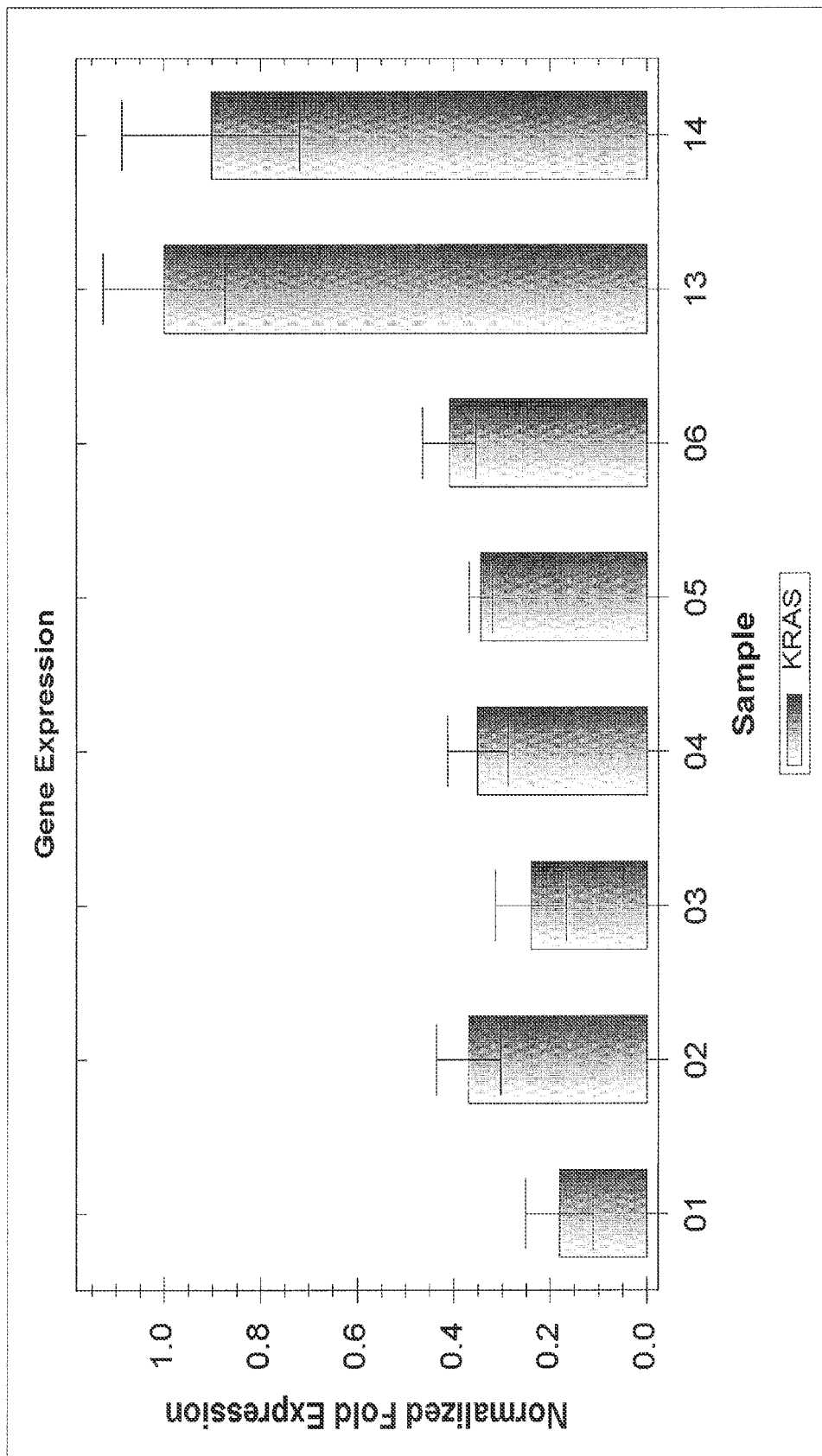

Figure 14

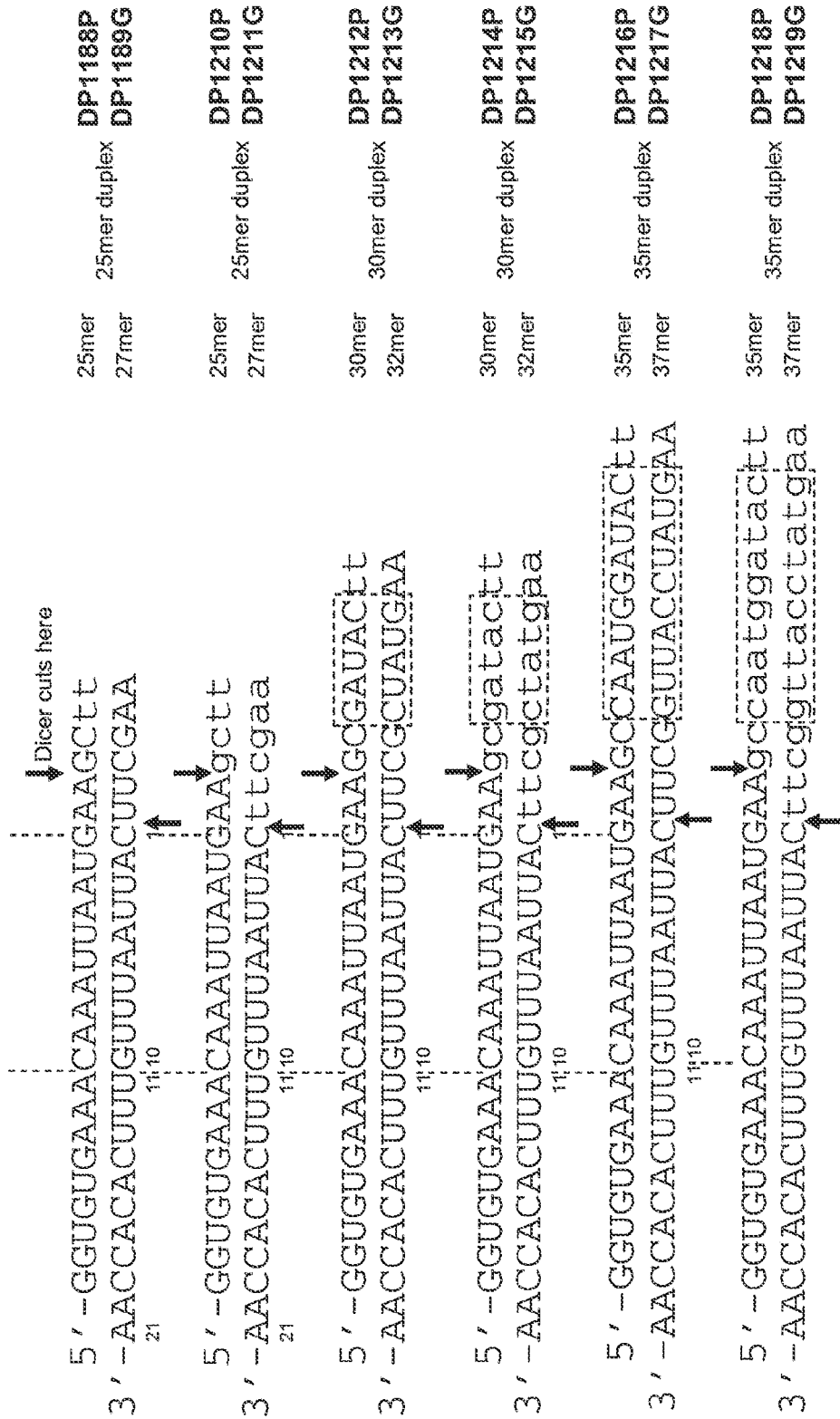
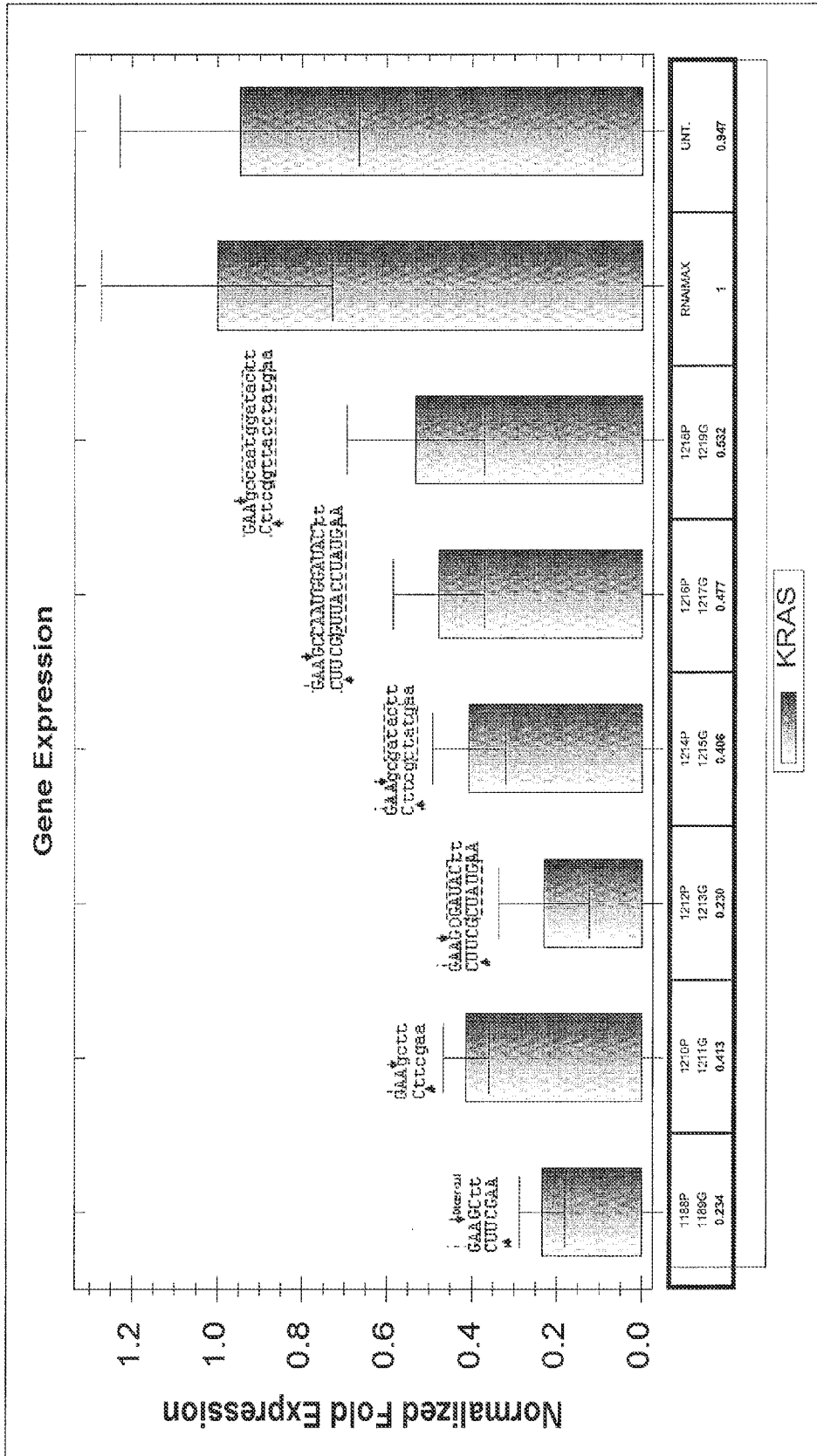

Figure 15



**Figure 16**

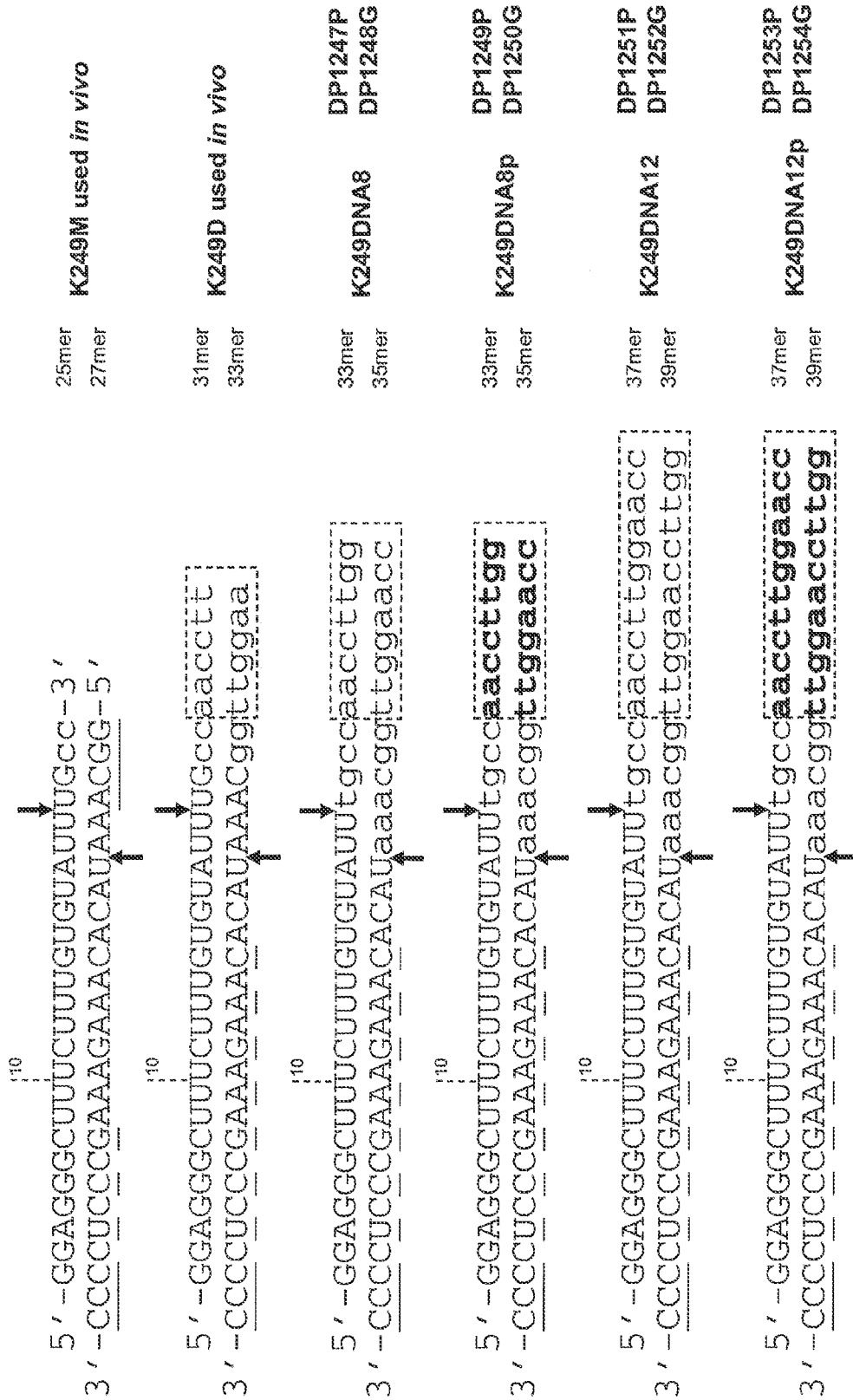

Figure 17

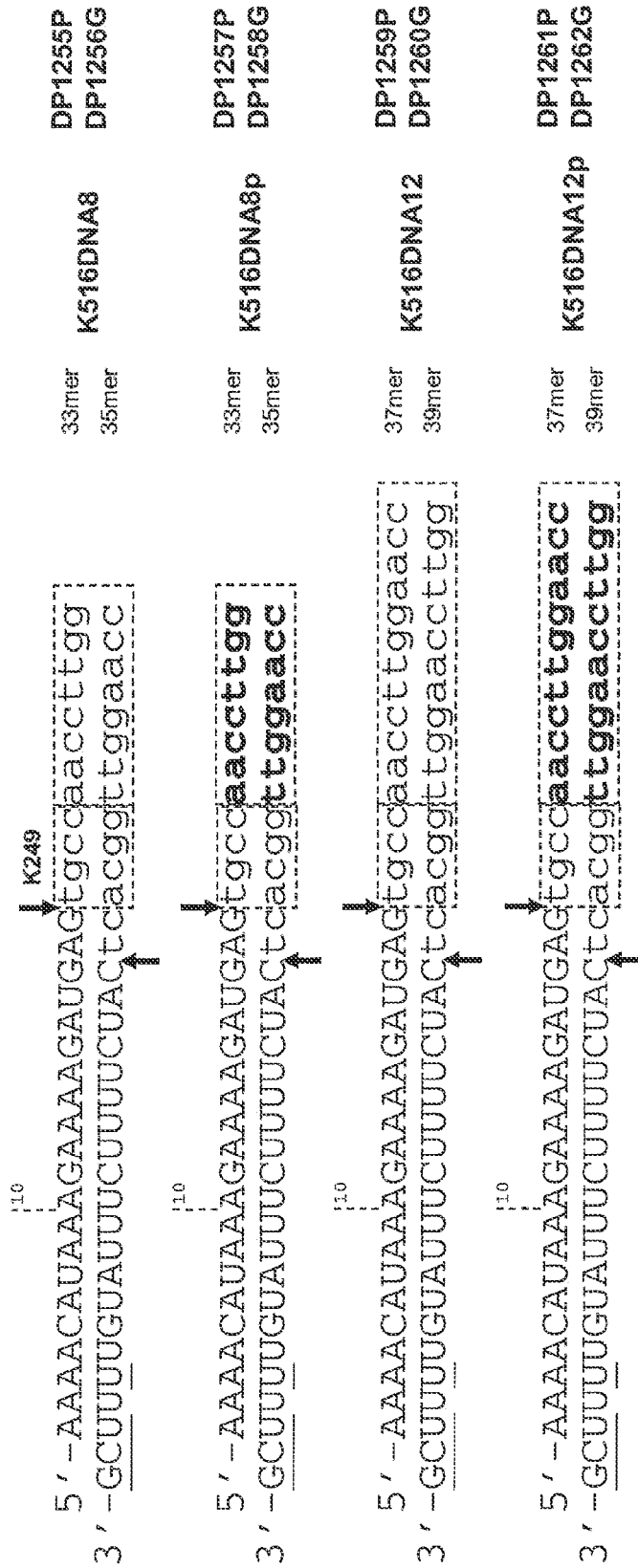



Figure 19

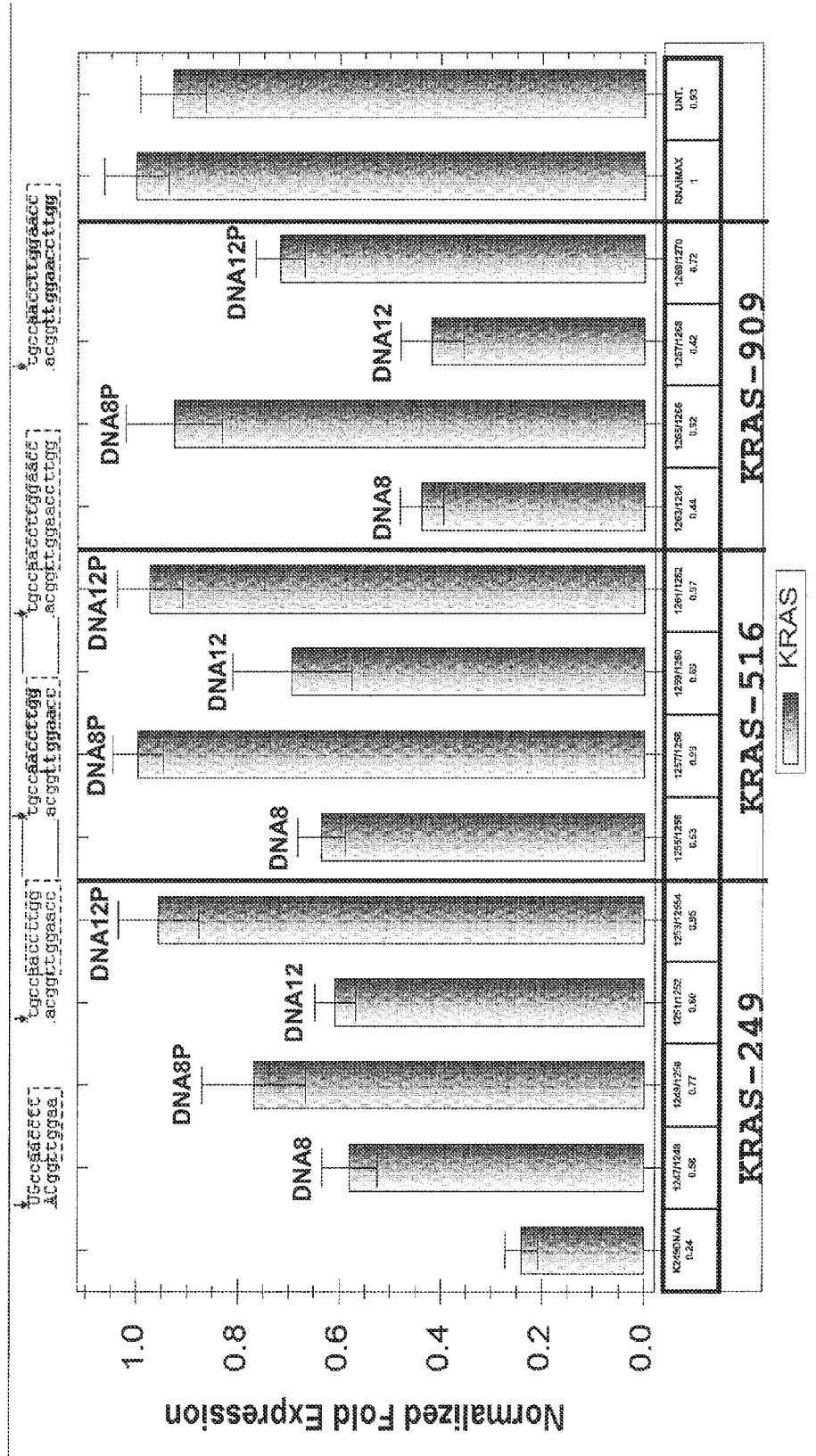



Figure 20

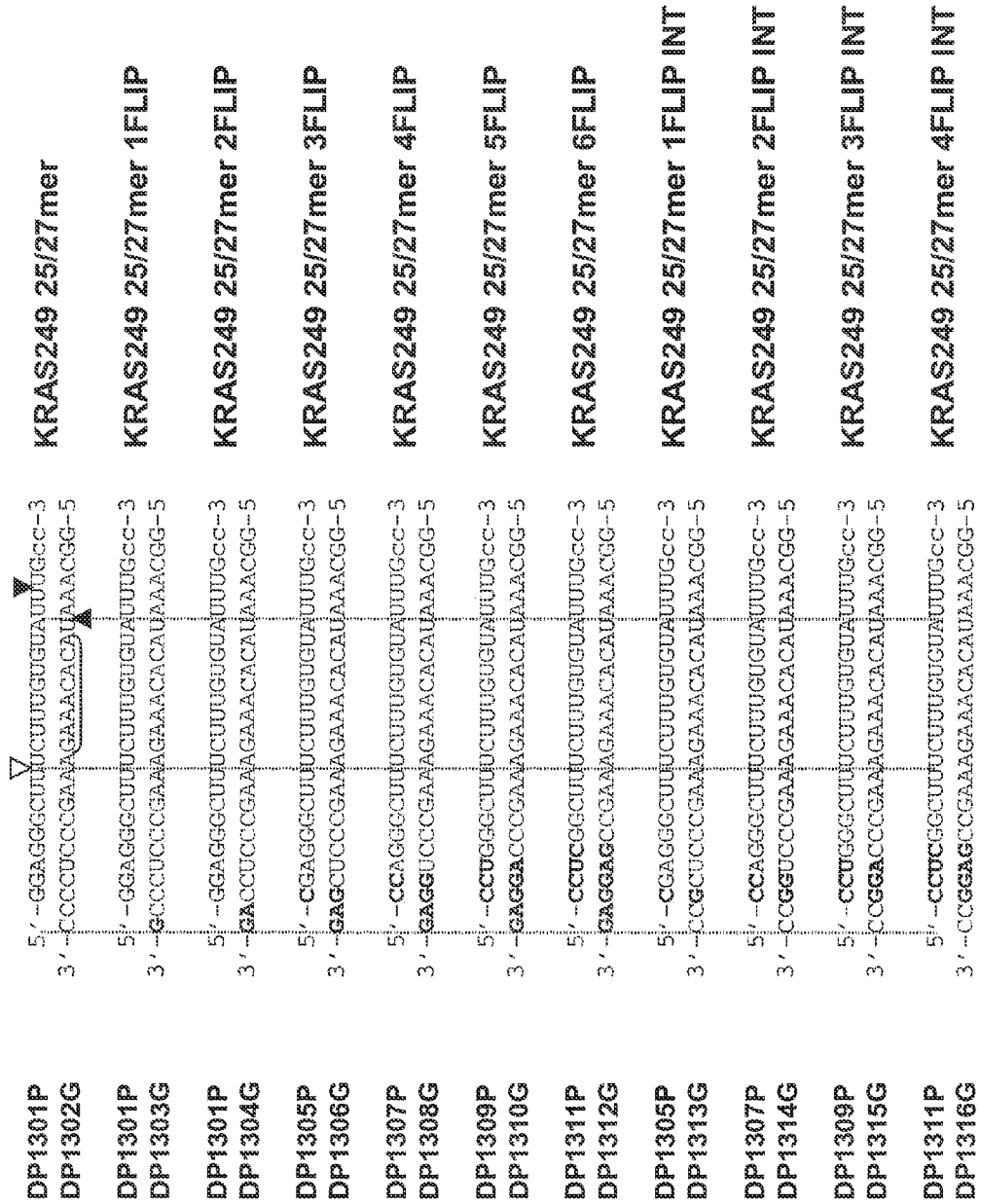

Figure 21

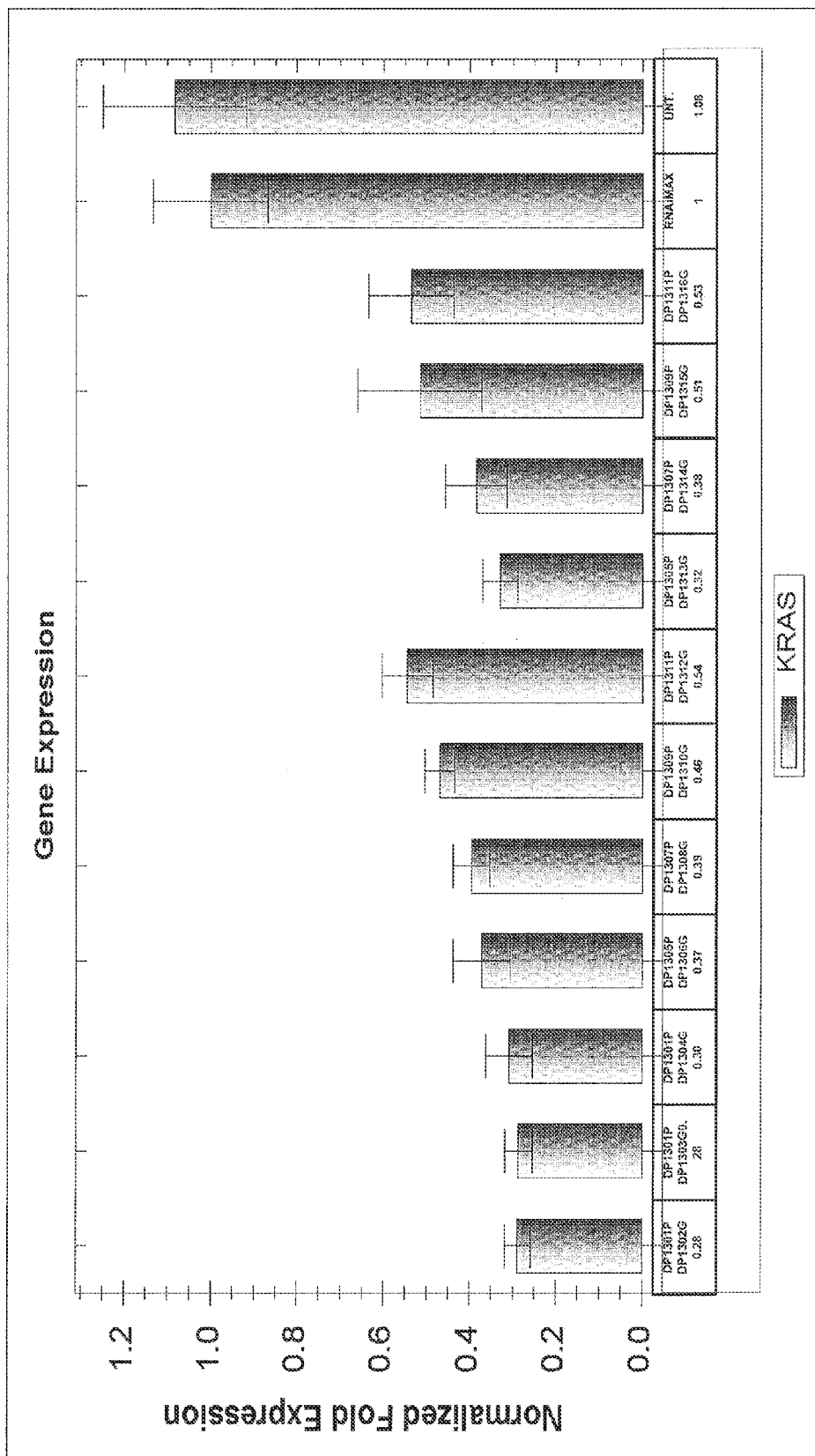

Figure 22

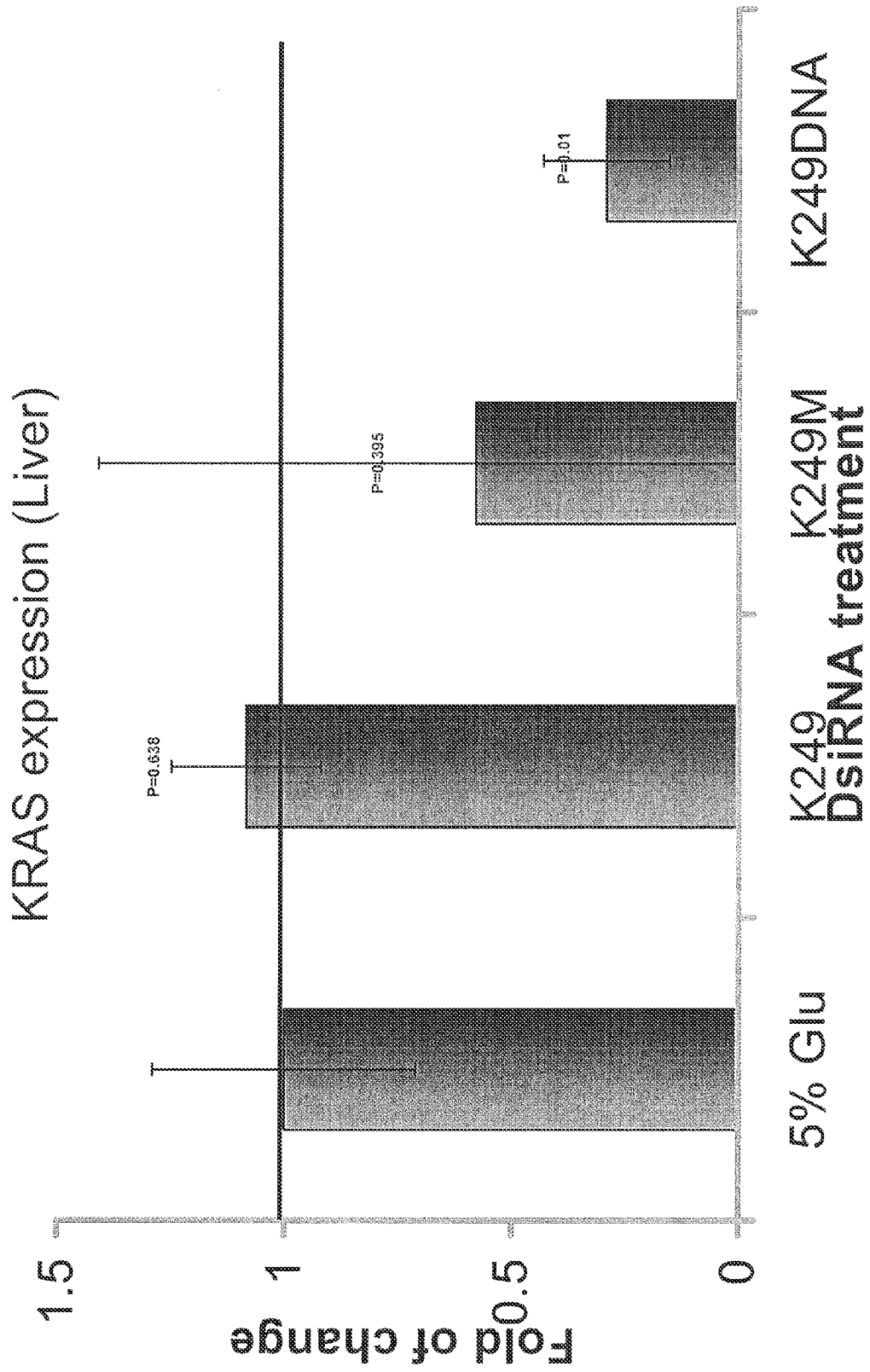

Figure 23

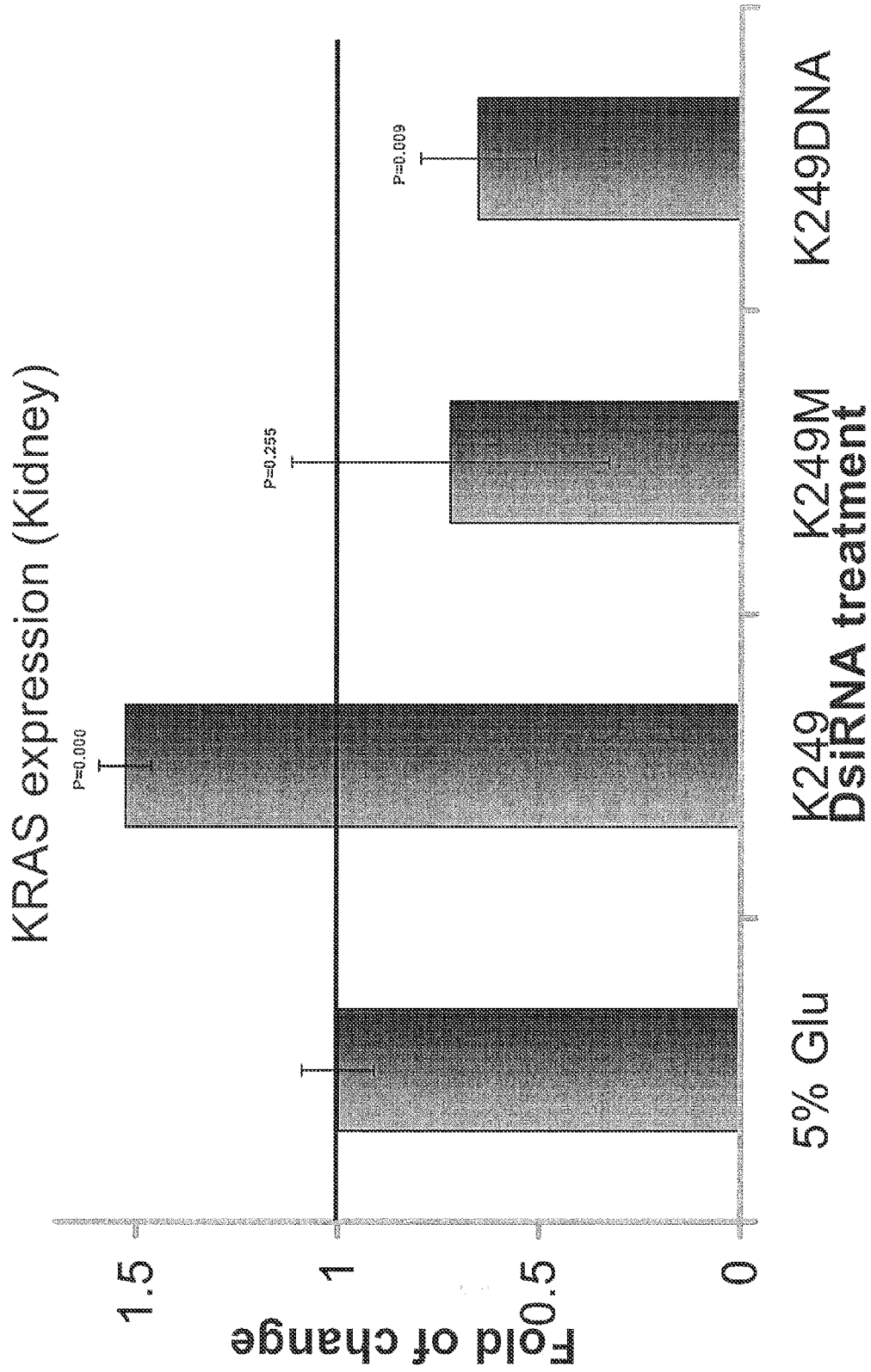

Figure 24

KRAS expression (Spleen)

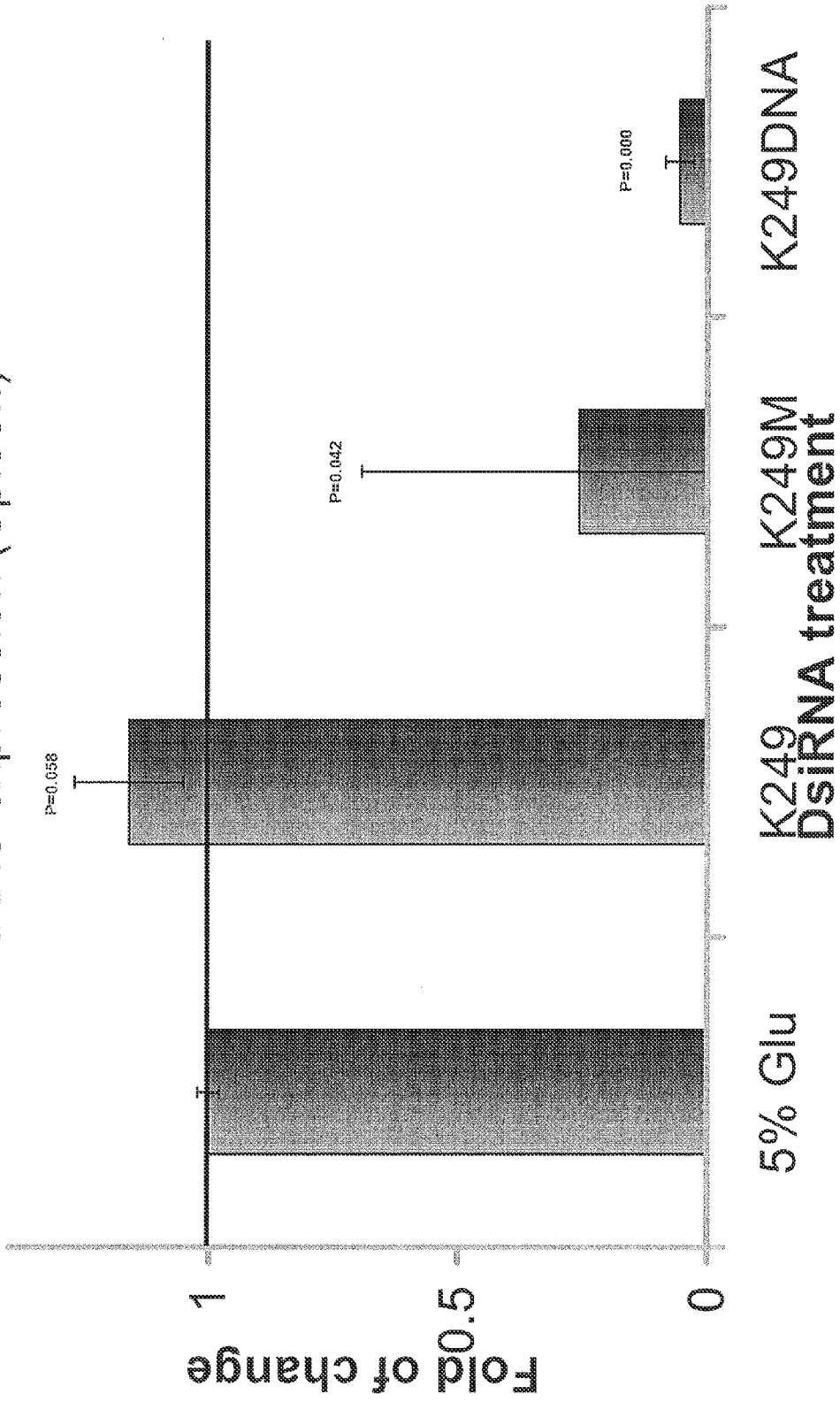

Figure 25

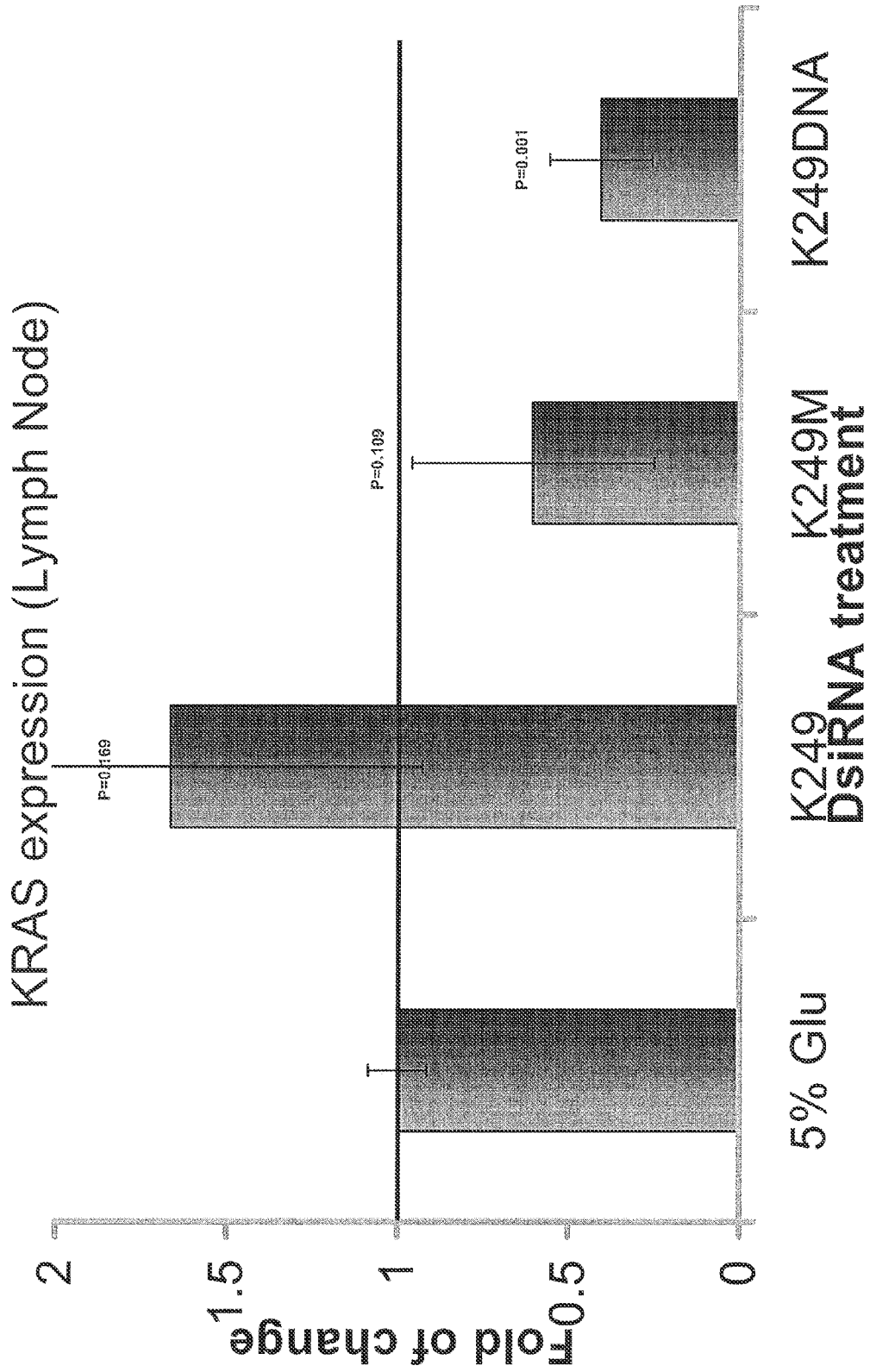

Figure 26

KRAS expression (Liver)

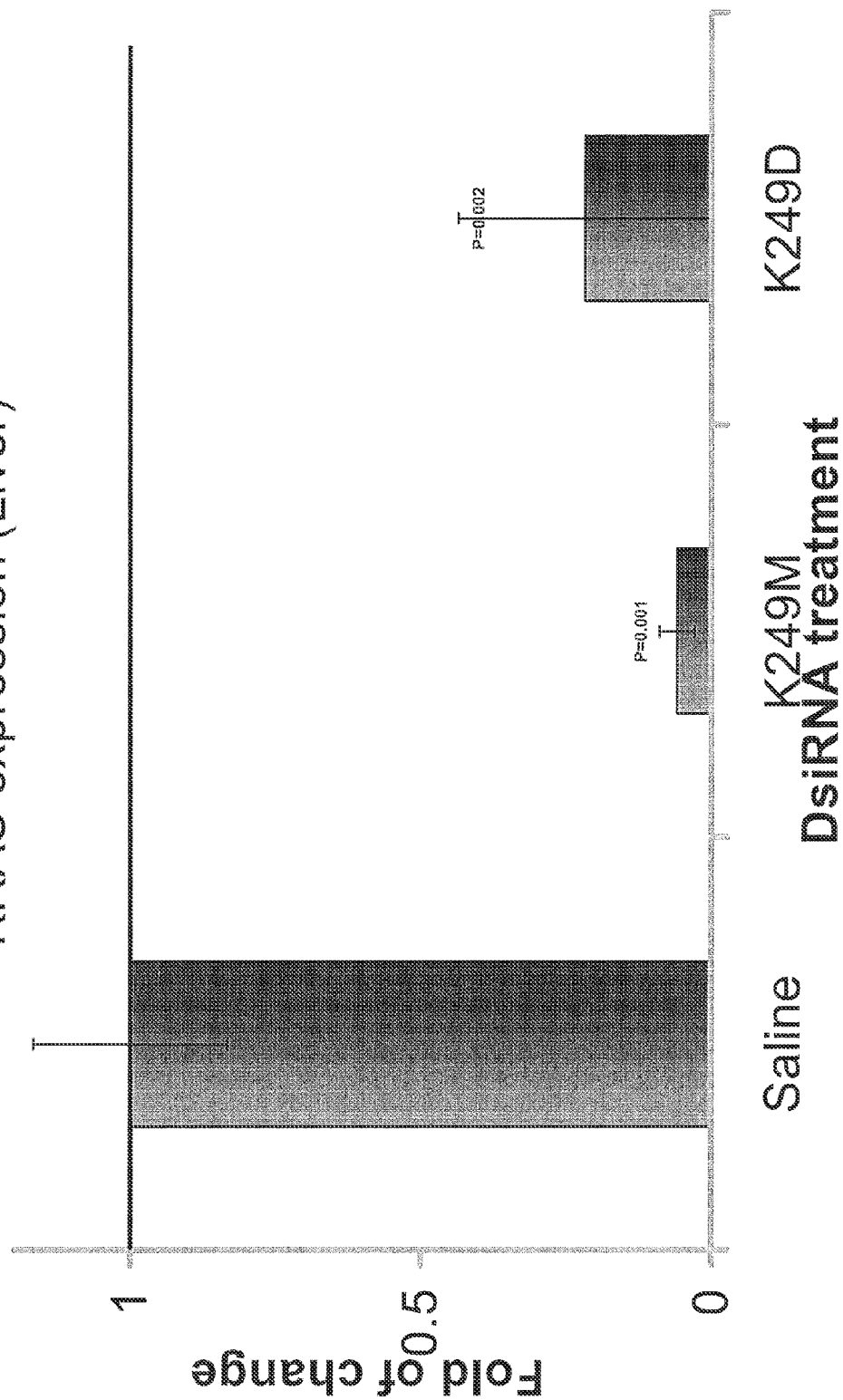

Figure 27

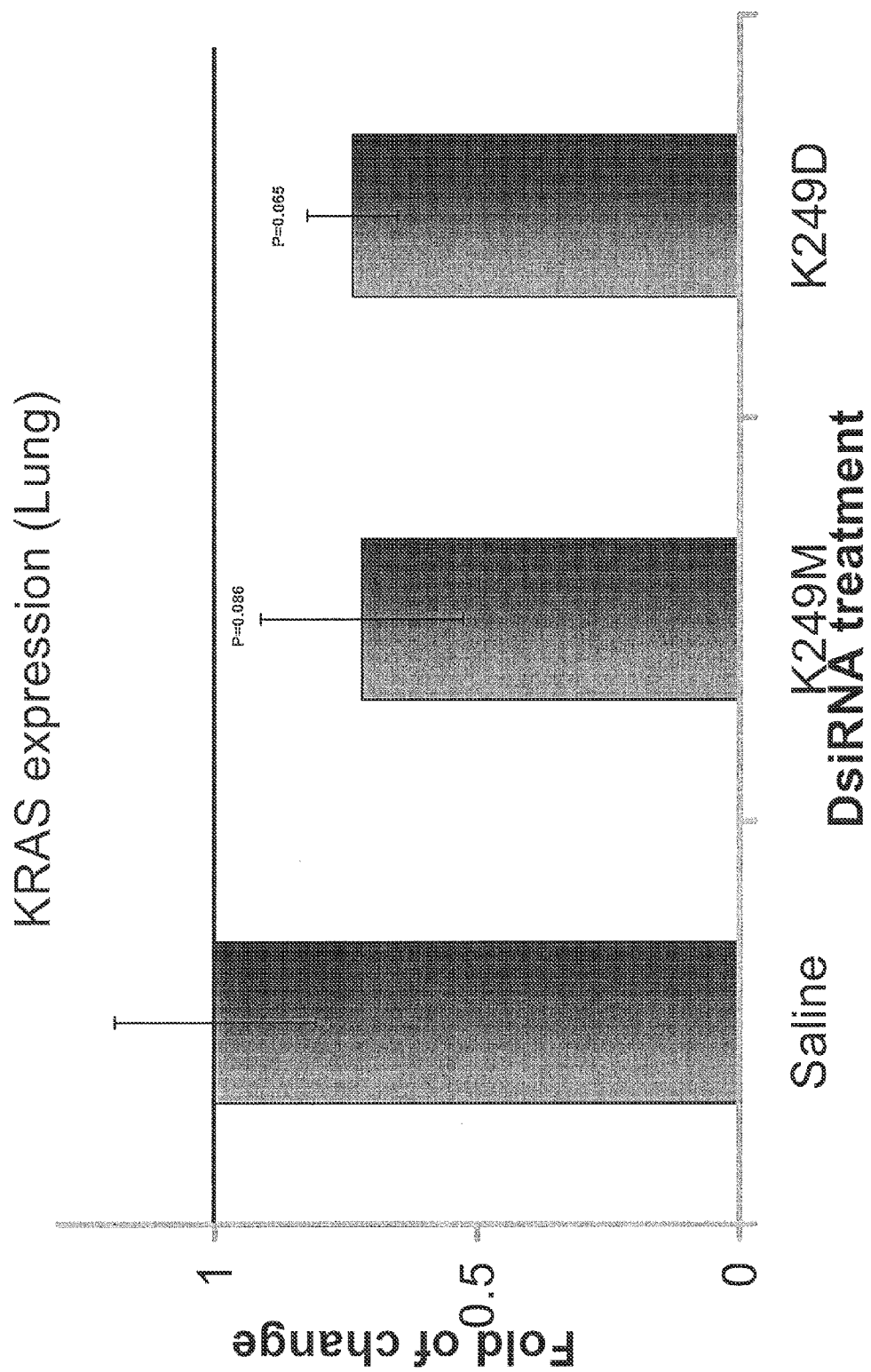



Figure 28

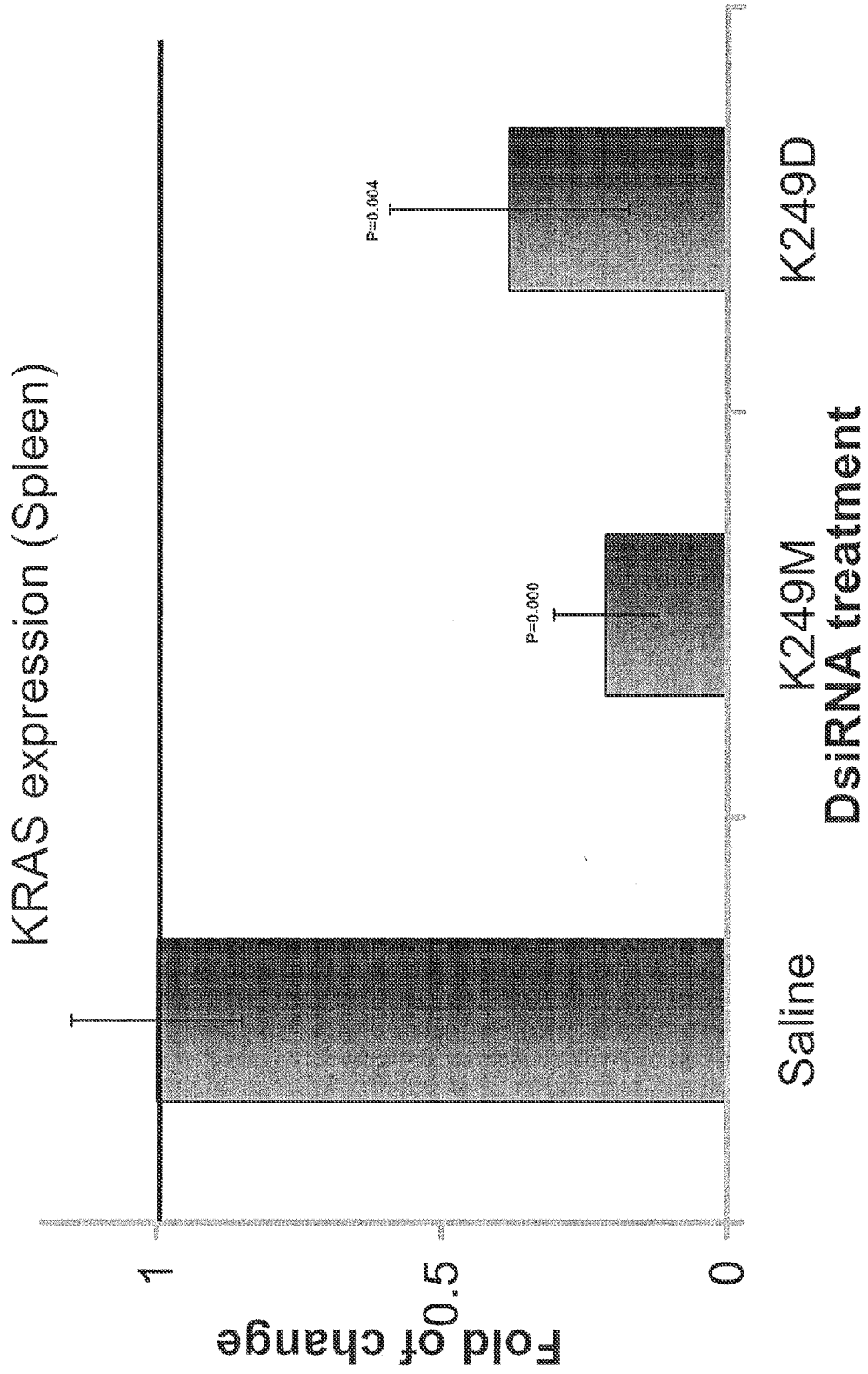

Figure 29

KRAS expression (Kidney)

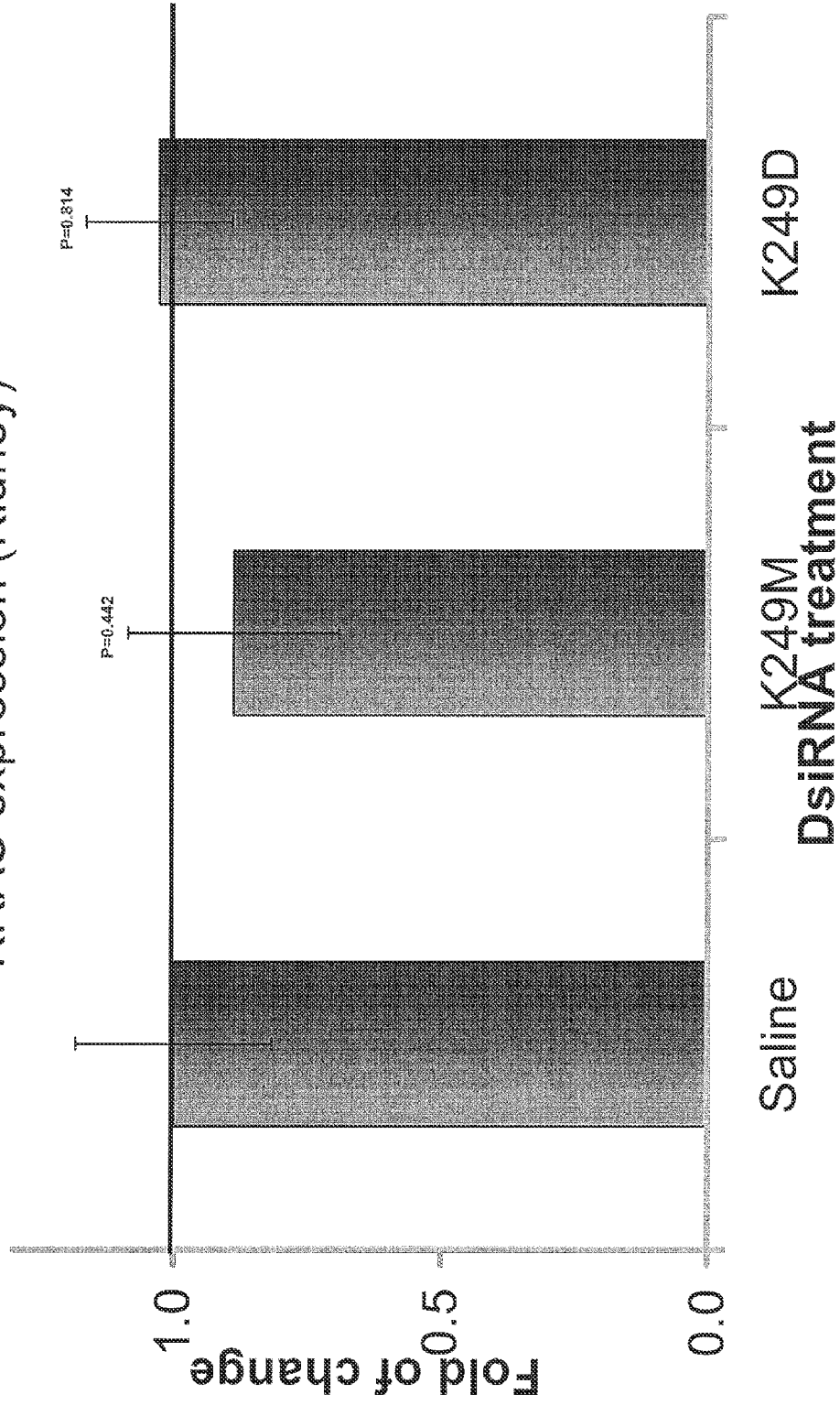

Figure 30

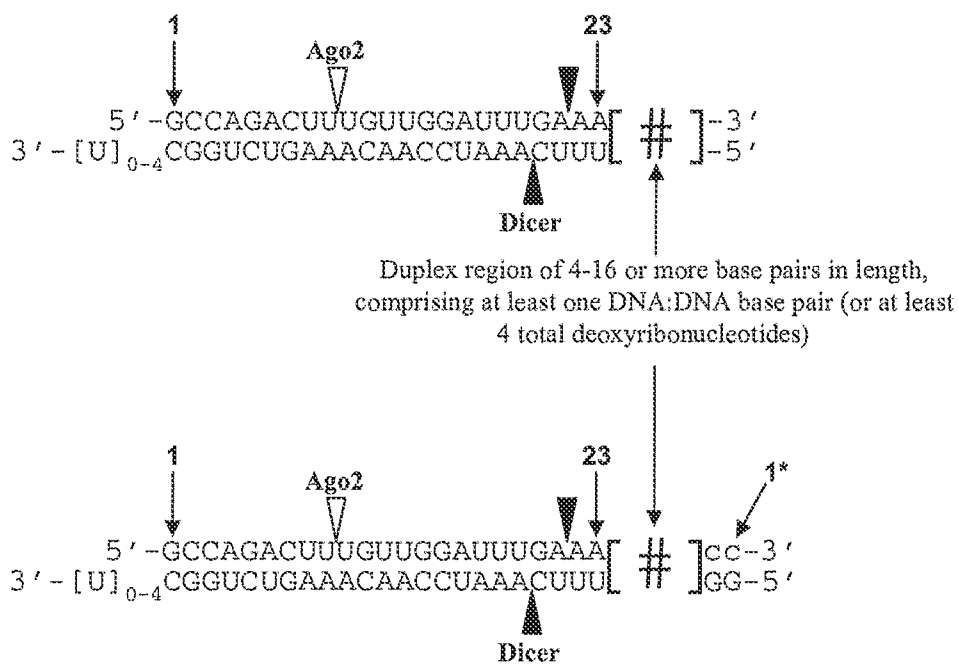

Figure 31

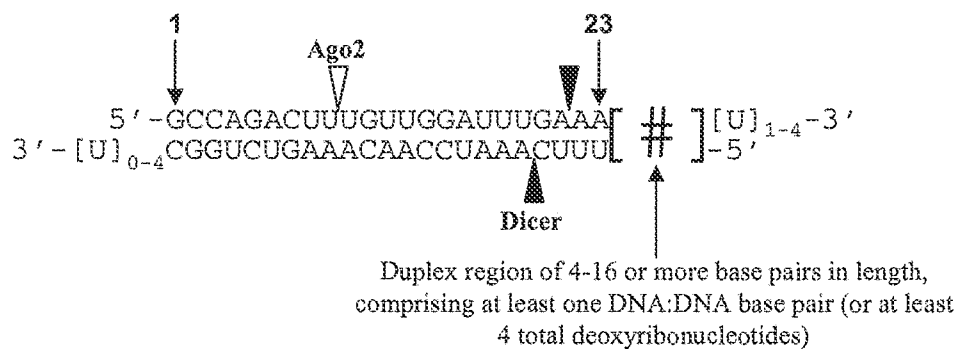

Figure 32

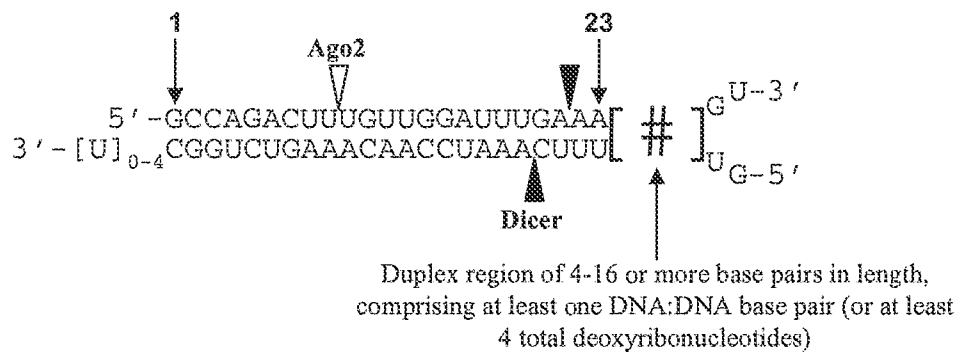

Figure 33

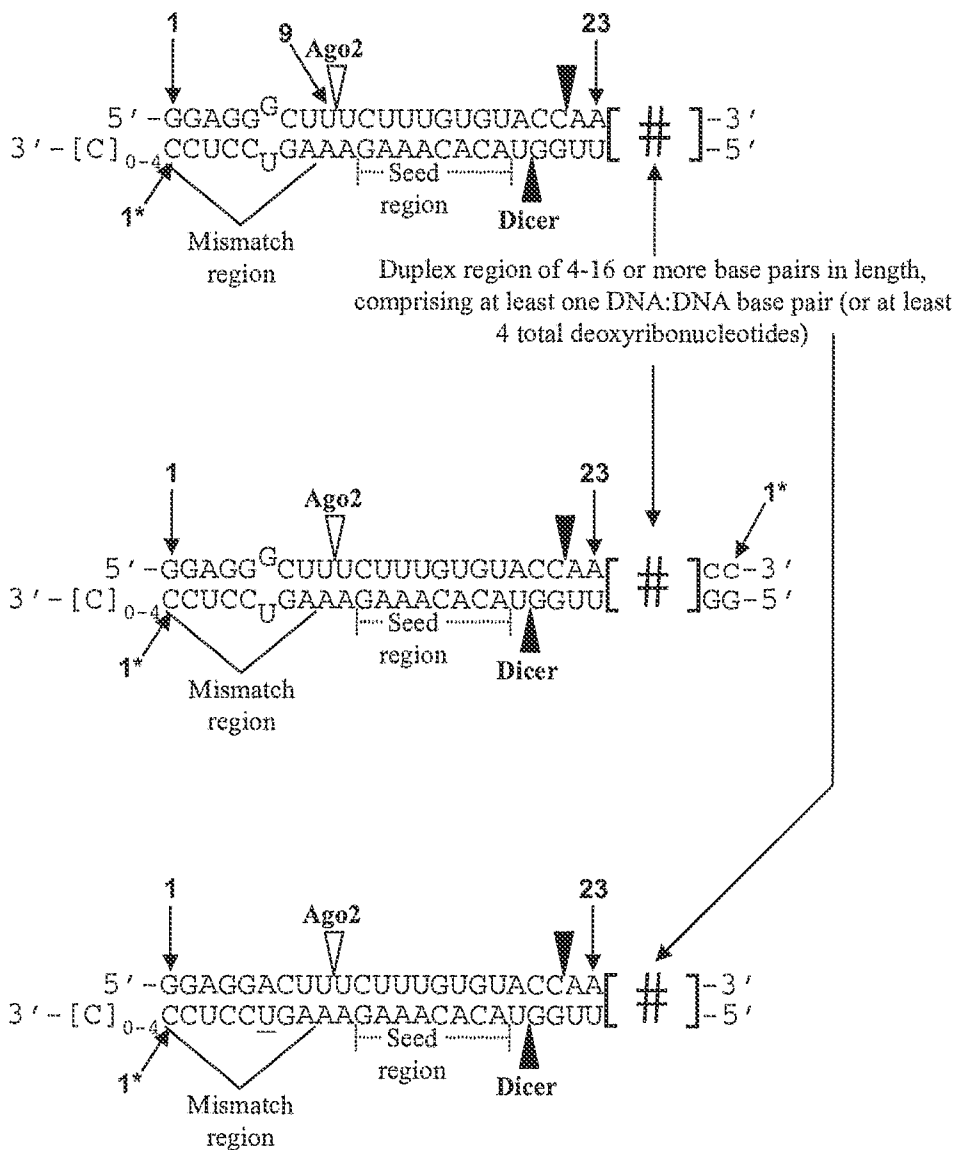

Figure 34

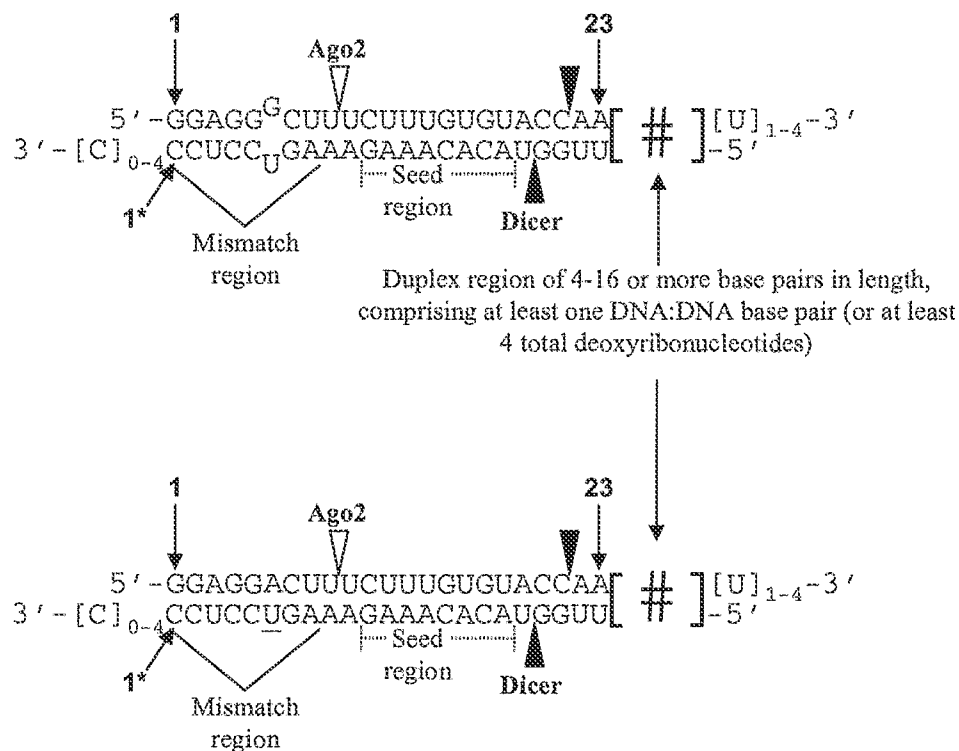

Figure 35

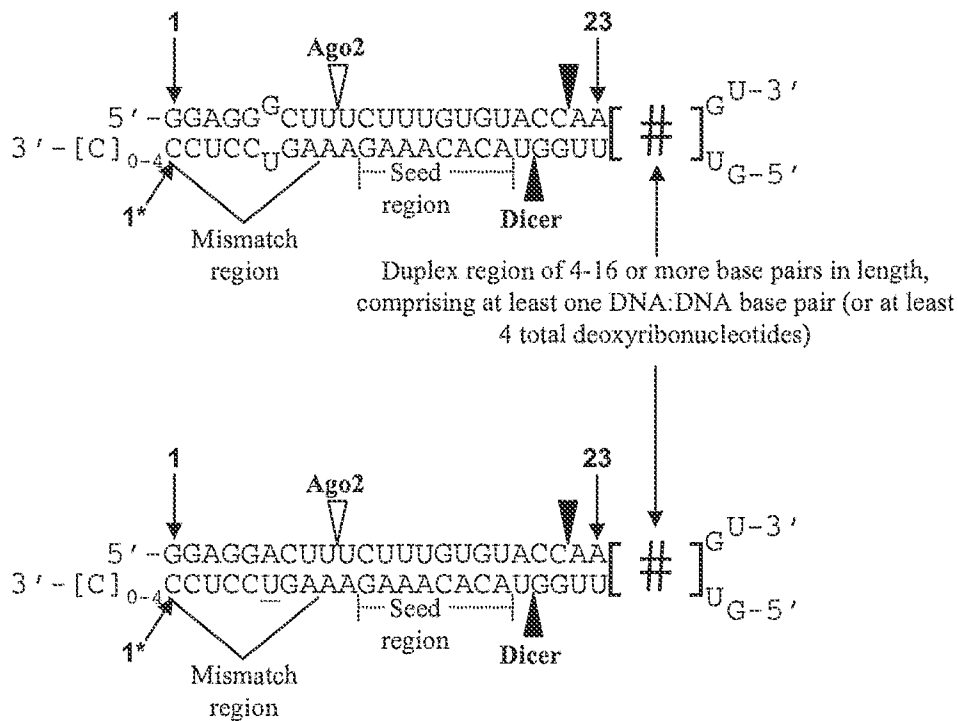
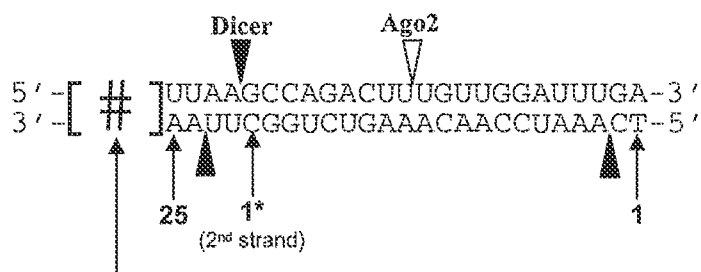



Figure 36



Duplex region of 4-16 or more base pairs in length,  
 comprising at least one DNA:DNA base pair (or at least  
 4 total deoxyribonucleotides)

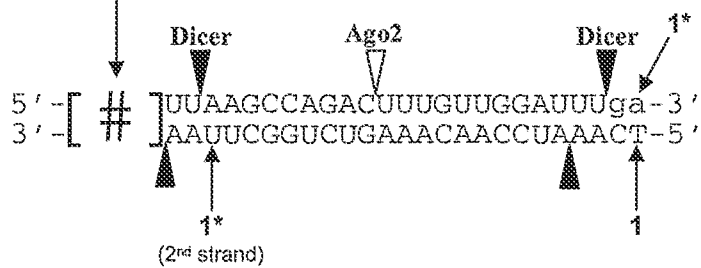

Figure 37

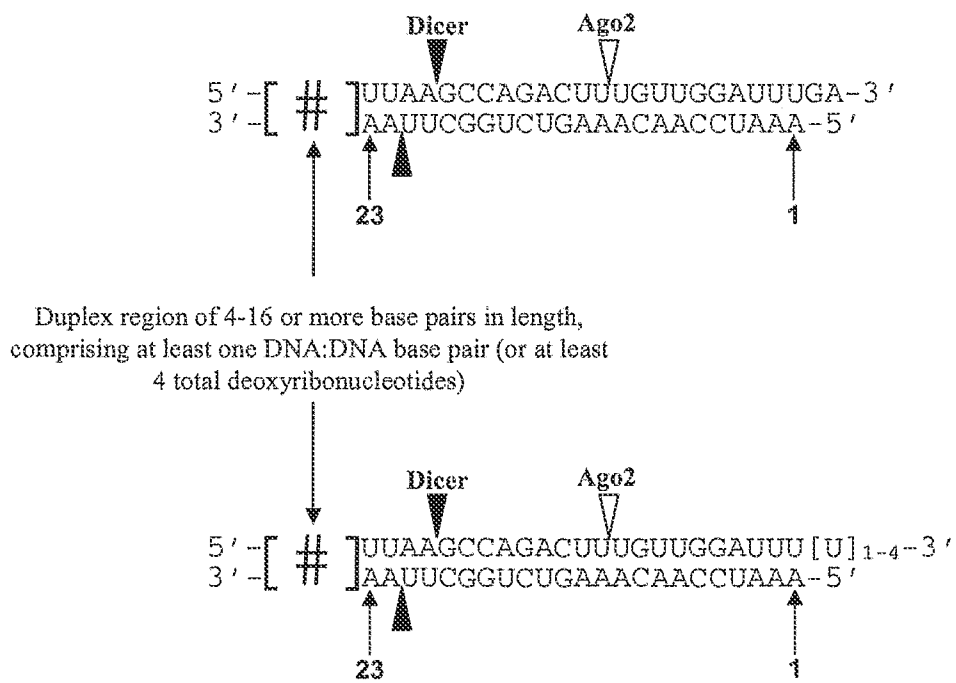
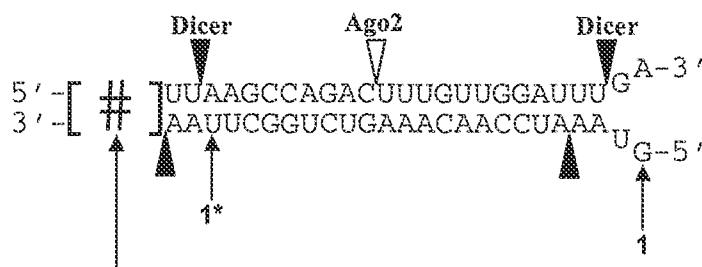
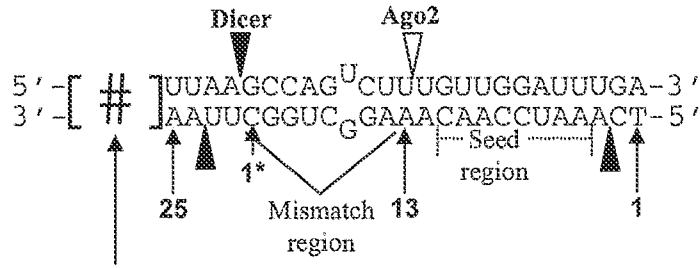

Figure 38



Duplex region of 4-16 or more base pairs in length,  
 comprising at least one DNA:DNA base pair (or at least  
 4 total deoxyribonucleotides)

Figure 39



Duplex region of 4-16 or more base pairs in length, comprising at least one DNA:DNA base pair (or at least 4 total deoxyribonucleotides)

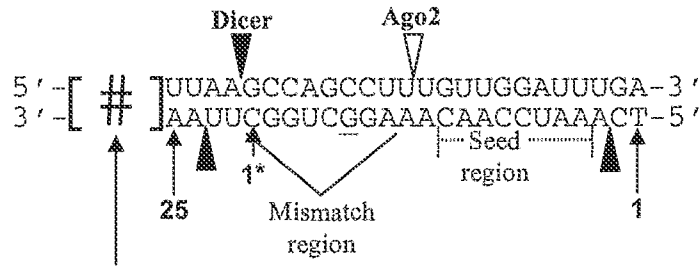
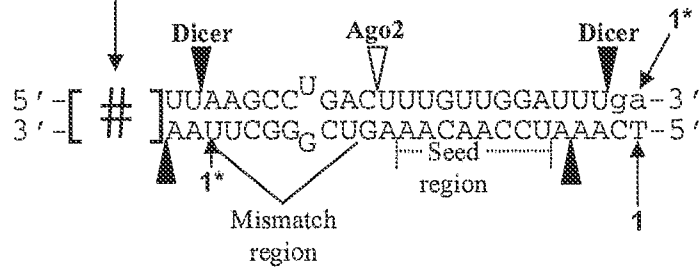

Duplex region of 4-16 or more base pairs in length, comprising at least one DNA:DNA base pair (or at least 4 total deoxyribonucleotides)

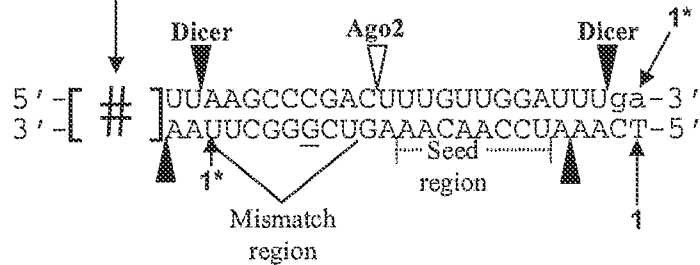

Figure 40

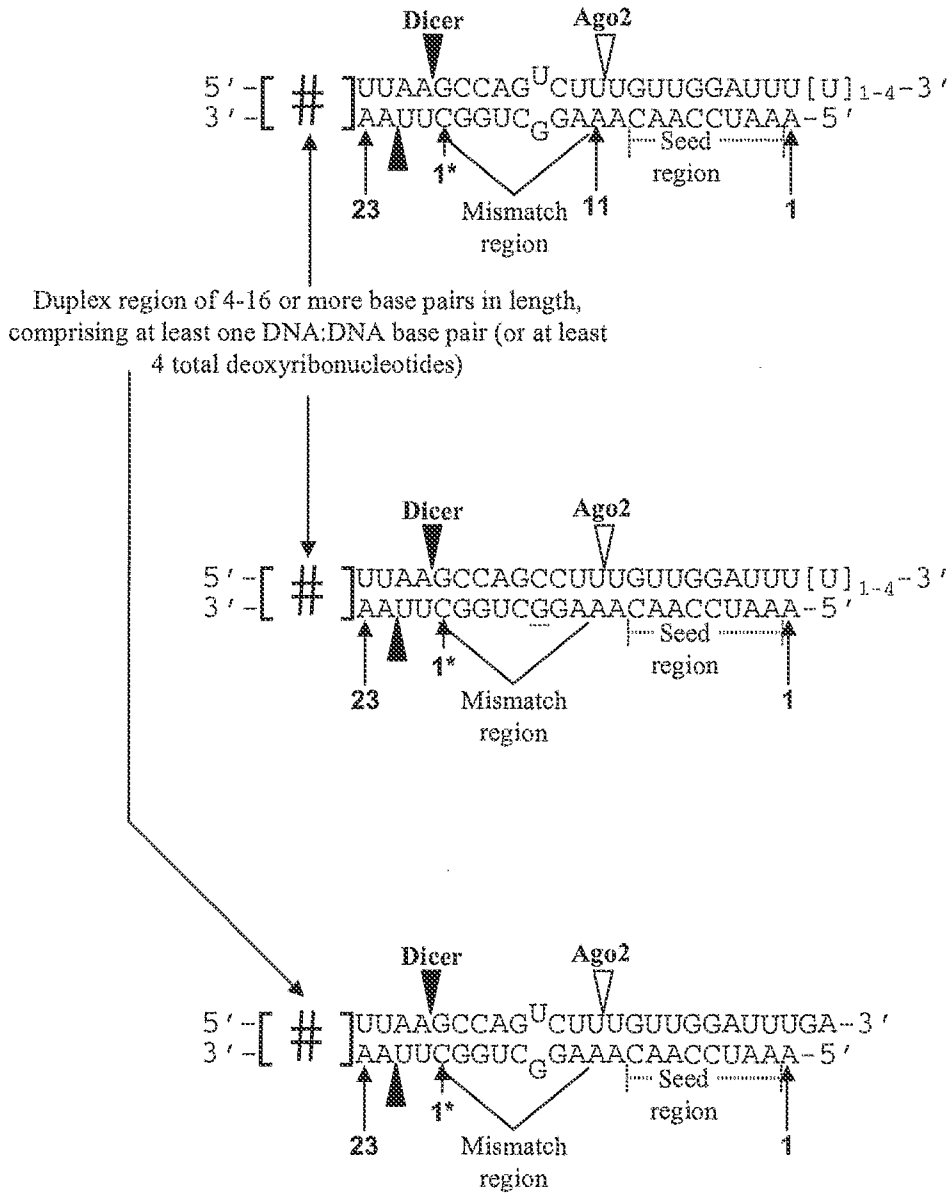

Figure 41

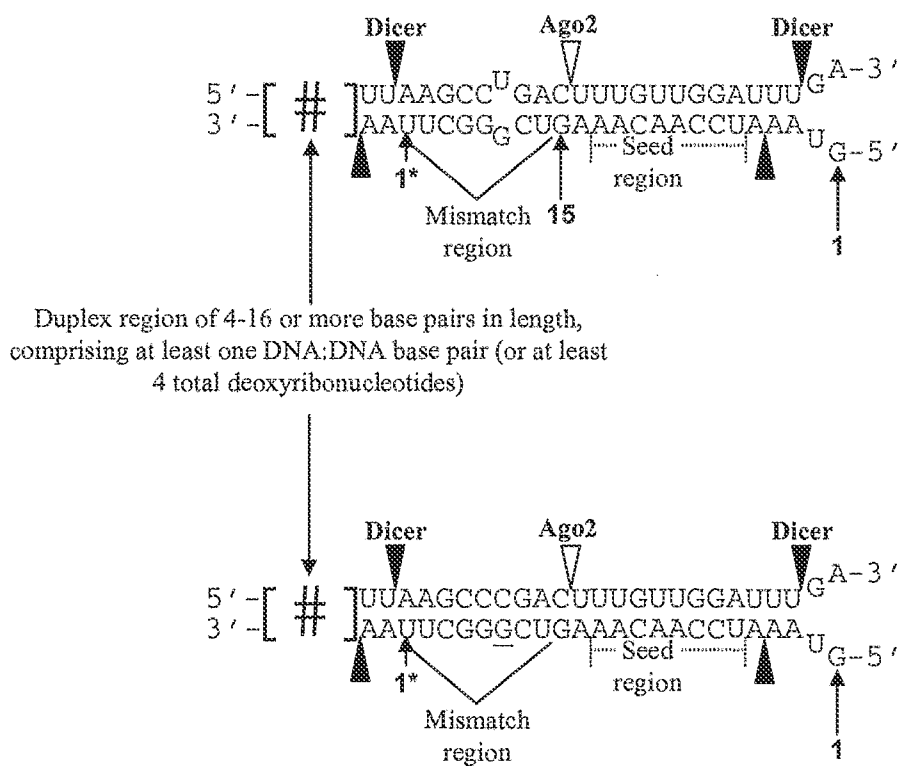

Figure 42A

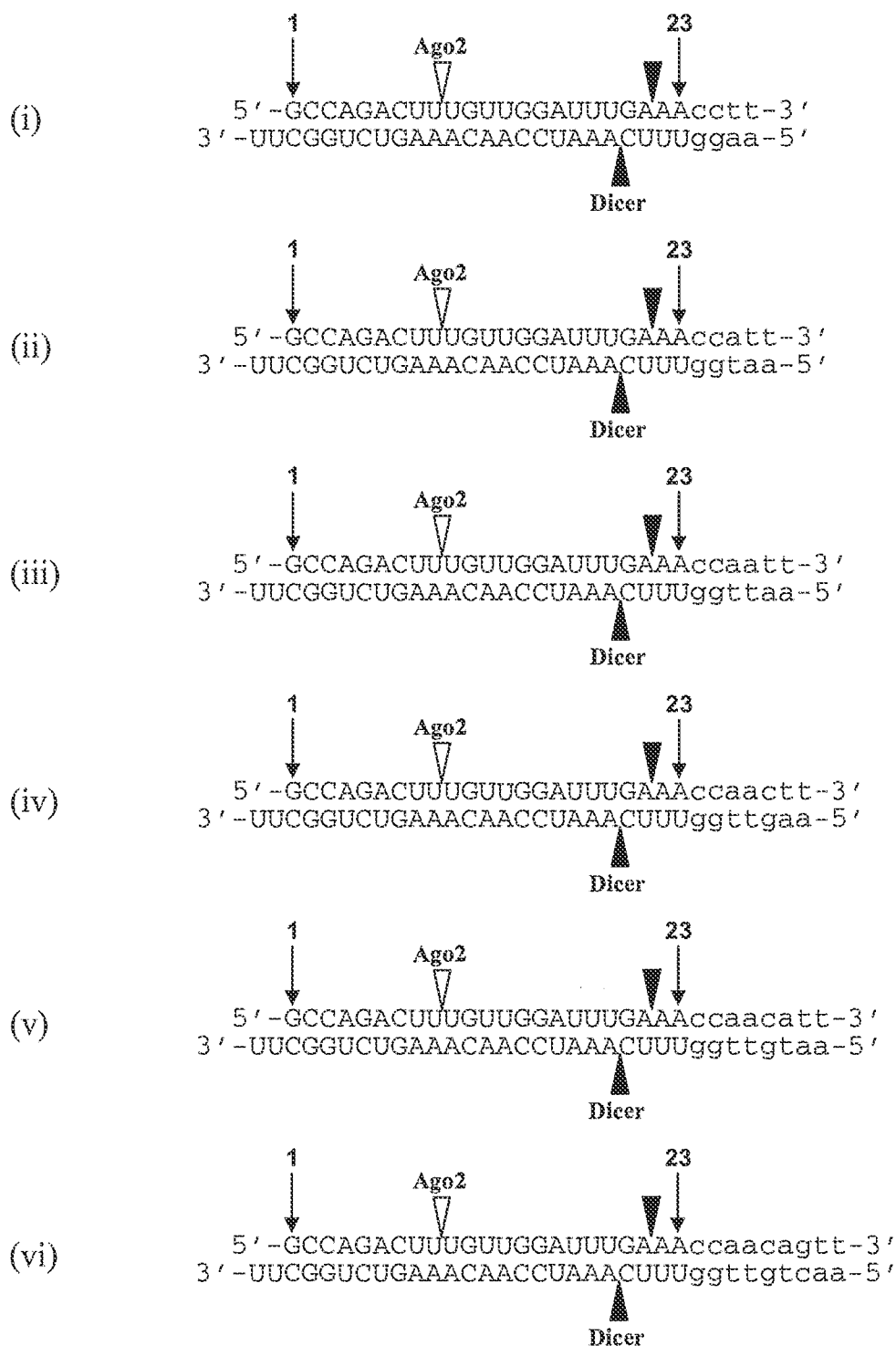

Figure 42B

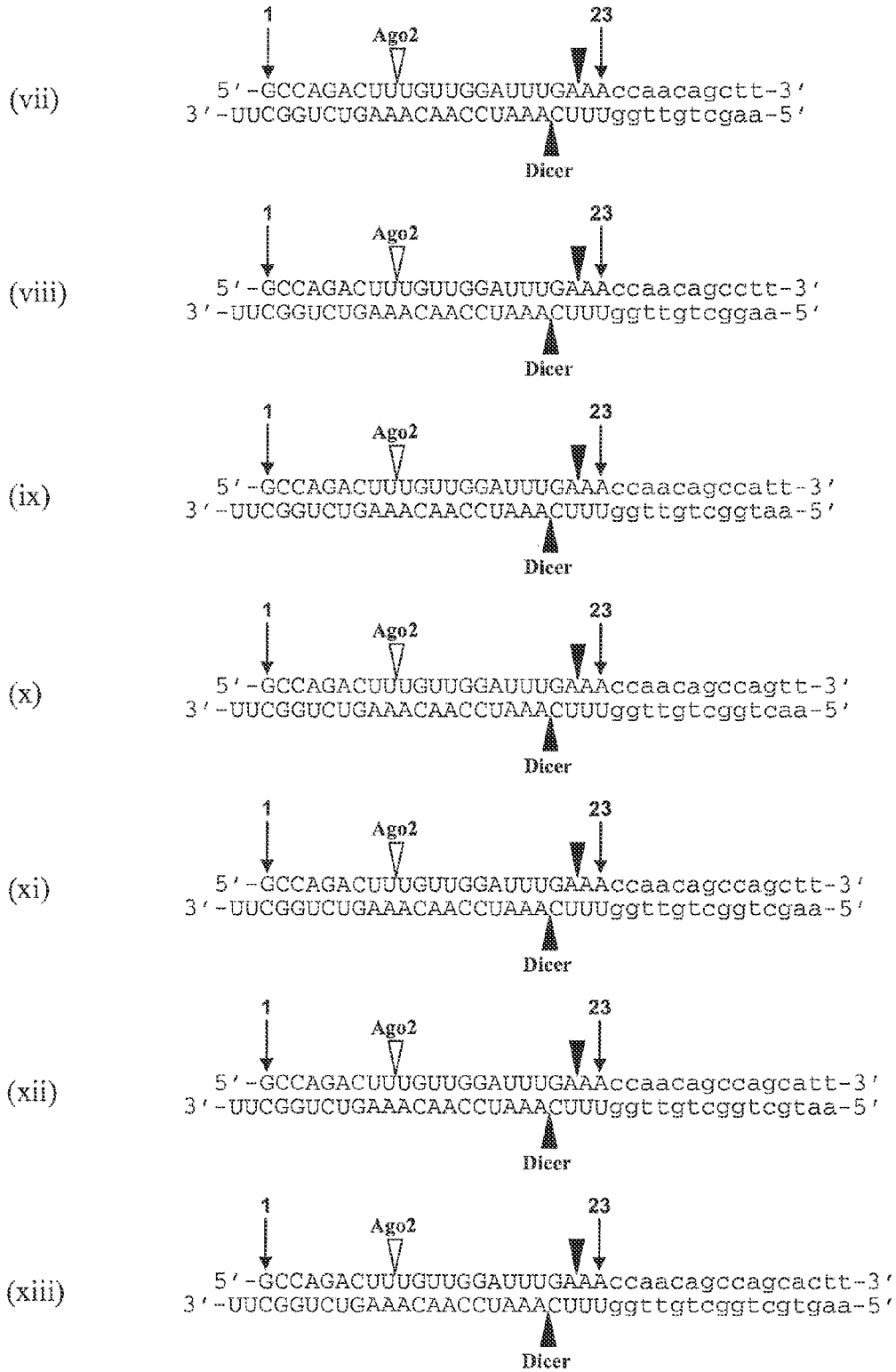



Figure 42C

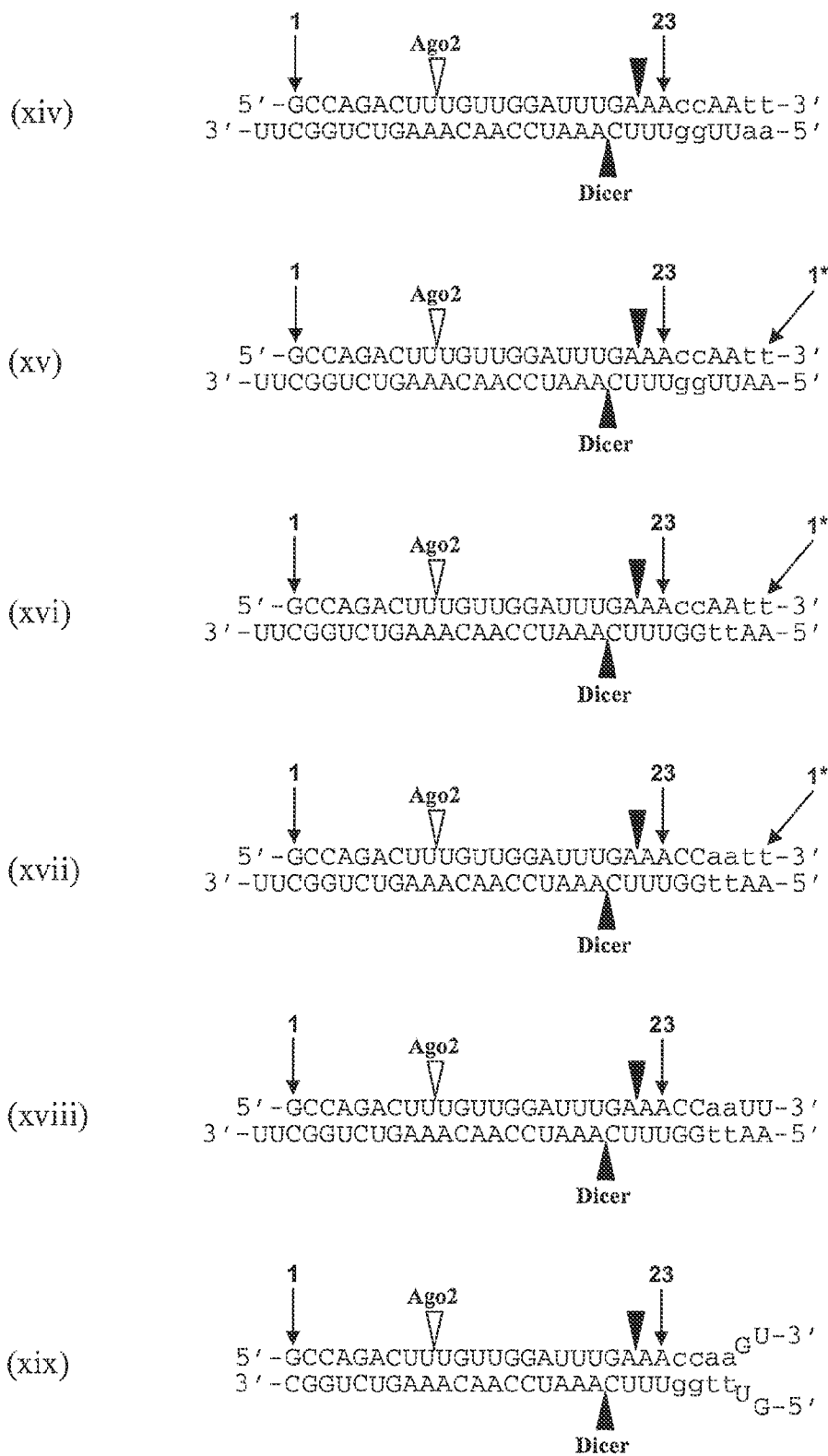

Figure 43A

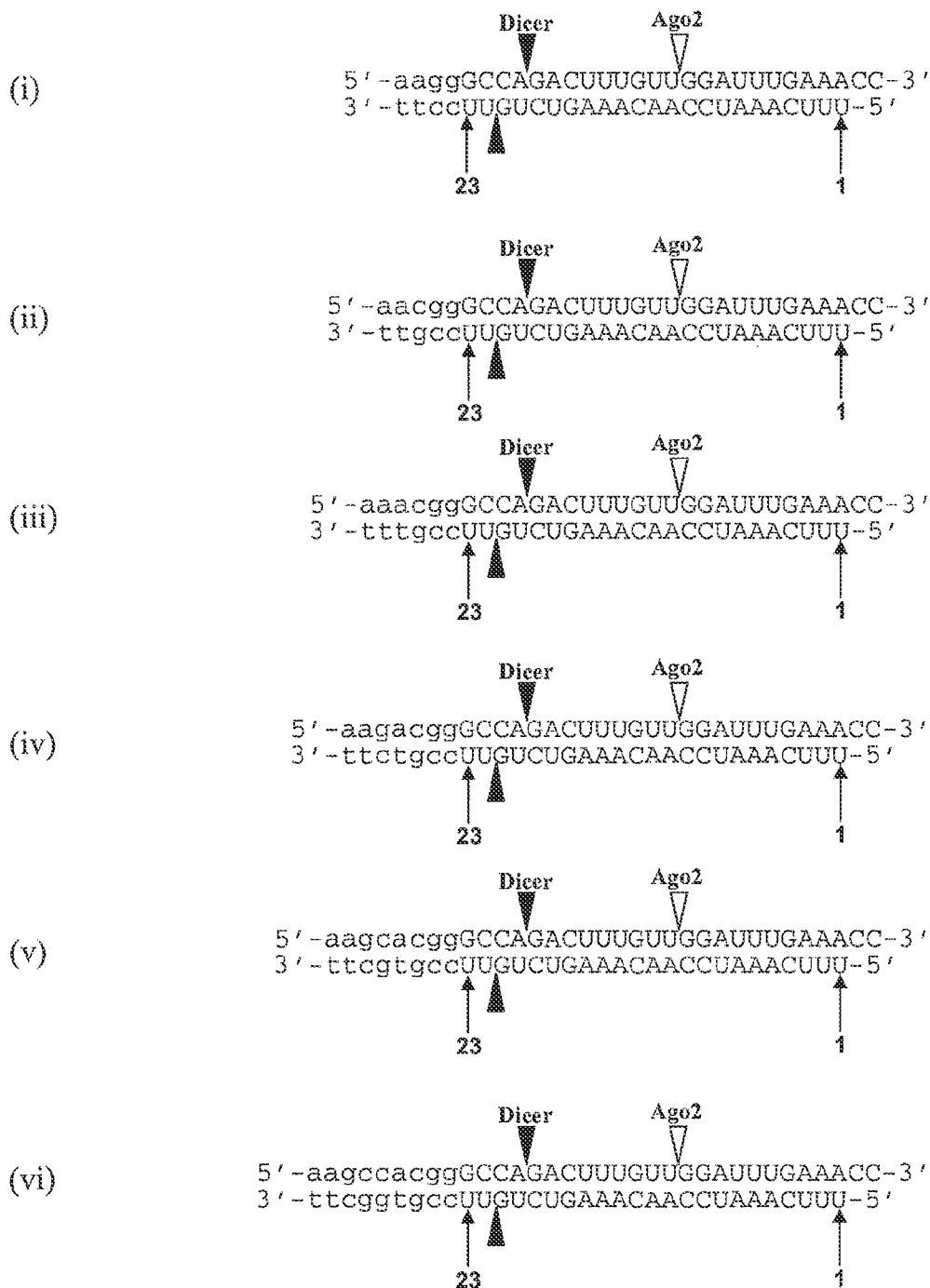

Figure 43B

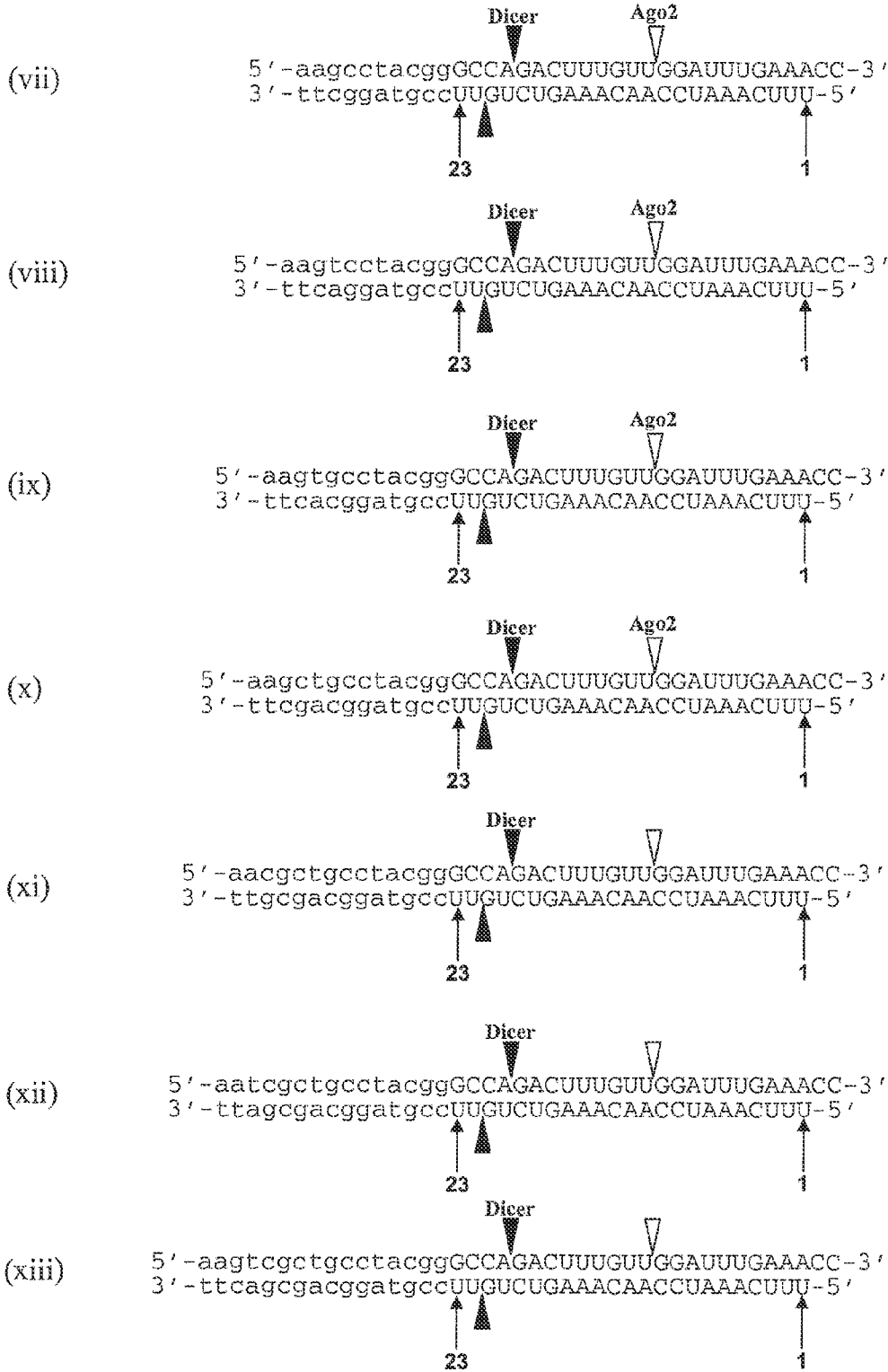
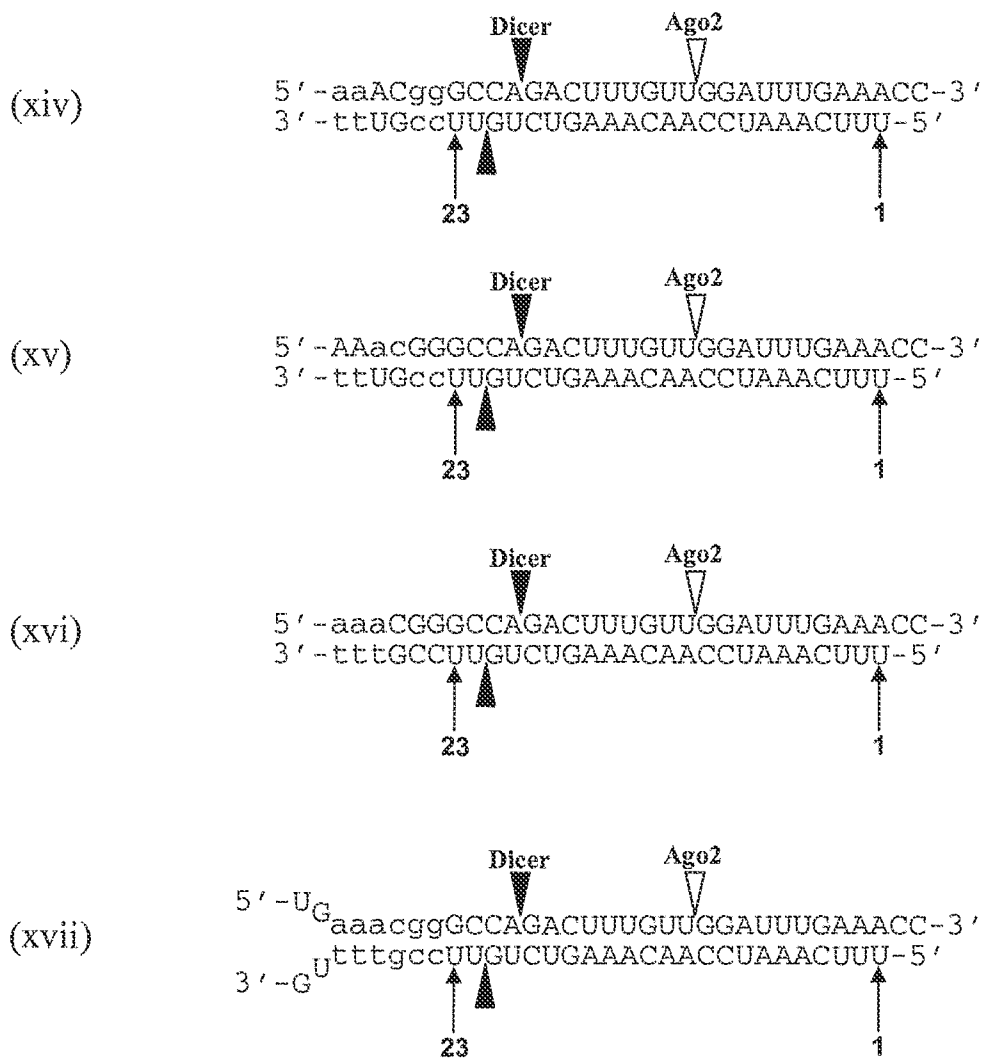

Figure 43C



**EXTENDED DICER SUBSTRATE AGENTS  
AND METHODS FOR THE SPECIFIC  
INHIBITION OF GENE EXPRESSION**

**CROSS-REFERENCE TO RELATED  
APPLICATIONS**

**[0001]** The present application is a Continuation of application Ser. No. 12/642,371 filed Dec. 18, 2009, which is related to and claims priority under 35 U.S.C. §119(e) to the following applications: U.S. provisional patent application No. 61/138,946, filed Dec. 18, 2008; U.S. provisional patent application No. 61/166,227, filed Apr. 2, 2009; U.S. provisional patent application No. 61/173,505, filed Apr. 28, 2009; U.S. provisional patent application No. 61/173,514, filed Apr. 28, 2009; U.S. provisional patent application No. 61/173,521, filed Apr. 28, 2009; U.S. provisional patent application No. 61/173,525, filed Apr. 28, 2009; U.S. provisional patent application No. 61/173,532, filed Apr. 28, 2009; U.S. provisional patent application No. 61/173,538, filed Apr. 28, 2009; U.S. provisional patent application No. 61/173,544, filed Apr. 28, 2009; U.S. provisional patent application No. 61/173,549, filed Apr. 28, 2009; U.S. provisional patent application No. 61/173,554, filed Apr. 28, 2009; U.S. provisional patent application No. 61/173,556, filed Apr. 28, 2009; U.S. provisional patent application No. 61/173,558, filed Apr. 28, 2009; and U.S. provisional patent application No. 61/173,563, filed Apr. 28, 2009. The entire teachings of the above applications are incorporated herein by reference.

**BACKGROUND OF THE INVENTION**

**[0002]** Double-stranded RNA (dsRNA) agents possessing strand lengths of 25 to 35 nucleotides have been described as effective inhibitors of target gene expression in mammalian cells (Rossi et al., U.S. Patent Publication Nos. 2005/0244858 and 2005/0277610). dsRNA agents of such length are believed to be processed by the Dicer enzyme of the RNA interference (RNAi) pathway, leading such agents to be termed "Dicer substrate siRNA" ("DsiRNA") agents. Certain modified structures of DsiRNA agents were previously described (Rossi et al., U.S. Patent Publication No. 2007/0265220).

**[0003]** While robust, sequence-specific target gene silencing efficacy has been identified for 25-35 nucleotide length dsRNA agents, a need exists for improved design of such agents, including design of DsiRNA agents possessing enhanced in vitro and in vivo efficacy.

**BRIEF SUMMARY OF THE INVENTION**

**[0004]** The present invention is based, at least in part, upon the surprising discovery that double stranded nucleic acid agents having strand lengths in the range of 27-39 nucleotides in length that possess base paired deoxyribonucleotides either at or near the 3' terminus of the sense strand/5' terminus of the antisense strand or at or near the 5' terminus of the sense strand/3' terminus of the antisense strand are effective RNA interference agents. Indeed, the instant invention relates to the demonstration that inclusion of base paired deoxyribonucleotides within a region of a Dicer substrate siRNA ("DsiRNAs") that is excised from a resultant active siRNA via Dicer enzyme cleavage, results in an effective inhibitory agent. Inclusion of one or more base paired deoxyribonucleotides within this region of a DsiRNA can impart certain advantages to such a modified DsiRNA molecule, including, e.g.,

enhanced efficacy (including enhanced potency and/or improved duration of effect), display of a recognition domain for DNA-binding molecules, and other attributes associated with a DNA:DNA duplex region. Indeed, such double stranded DNA:DNA-extended DsiRNA agents were demonstrated to possess enhanced efficacy, especially including improved potency, relative to corresponding double stranded RNA:DNA- or RNA:RNA-extended DsiRNA agents.

**[0005]** Among the advantages of the instant invention, the surprising discovery that DNA-extended DsiRNA agents do not exhibit decreased efficacy as duplex length increases allows for the generation of DsiRNAs that remain effective RNA inhibitory agents while providing greater spacing for, e.g., attachment of DsiRNAs to additional functional groups, inclusion/patterning of stabilizing modifications (e.g., PS-NA moieties) or other forms of modifications capable of adding further functionality and/or enhancing, e.g., pharmacokinetics, pharmacodynamics or biodistribution of such agents, as compared to dsRNA agents of corresponding length that do not contain such double stranded DNA-extended domains. The effect of such dsDNA-extension regions appears not to result from a stabilizing activity inherent in dsDNA regions, but rather appears to be attributable to the ability of specifically localized deoxyribonucleotide residues (either located 3' of the projected Dicer cleavage site of the first strand and correspondingly 5' of the projected Dicer cleavage site of the second strand or located 5' of the projected Dicer cleavage site of the first strand and correspondingly 3' of the projected Dicer cleavage site of the second strand) to direct Dicer cleavage such that a preferred cleavage product and/or population of cleavage products is generated and/or is made more prevalent.

**[0006]** Thus, in certain aspects, the instant invention allows for design of RNA inhibitory agents possessing enhanced efficacies at greater length (via more precise direction of the location of Dicer cleavage events) than previously described RNA inhibitory agents, thereby allowing for generation of dsRNA-containing agents possessing enhanced efficacy, delivery, pharmacokinetic, pharmacodynamic and biodistribution attributes, as well as improved ability, e.g., to be successfully formulated, to be attached to an active drug molecule and/or payload, to be attached to another active nucleic acid molecule, to be attached to a detection molecule, to possess (e.g., multiple) stabilizing modifications, etc.

**[0007]** In one aspect, the invention provides an isolated double stranded nucleic acid (dsNA) having a first and a second oligonucleotide strand, where the first strand is 27 to 49 nucleotide residues in length, and starting from the first nucleotide (position 1) at the 5' terminus of the first strand, positions 1 to 23 of the first strand are ribonucleotides; where the second strand is 27 to 53 nucleotide residues in length and includes 23 consecutive ribonucleotides that base pair with the ribonucleotides of positions 1 to 23 of the first strand to form a duplex; the 5' terminus of the first strand and the 3' terminus of the second strand form a blunt end or a 1-4 nucleotide 3' overhang; the 3' terminus of the first strand and the 5' terminus of the second strand form a blunt end; at least one of positions 24 to the 3' terminal nucleotide residue of the first strand is a deoxyribonucleotide that base pairs with a deoxyribonucleotide of the second strand; and the second strand is sufficiently complementary to a target RNA along at least 19 ribonucleotides of the second strand length to reduce target gene expression when the dsNA is introduced into a mammalian cell.

**[0008]** In one embodiment, two or more nucleotide residues of positions 24 to the 3' terminal nucleotide residue of the first strand are deoxyribonucleotides that base pair with deoxyribonucleotides of the second strand. In another embodiment, four or more nucleotide residues of positions 24 to the 3' terminal nucleotide residue of the first strand are deoxyribonucleotides that base pair with deoxyribonucleotides of the second strand. Optionally, six or more nucleotide residues, eight or more nucleotide residues, ten or more nucleotide residues, twelve or more nucleotide residues, fourteen or more nucleotide residues, sixteen or more nucleotide residues, eighteen or more nucleotide residues, or twenty or more nucleotide residues of positions 24 to the 3' terminal nucleotide residue of the first strand are deoxyribonucleotides that base pair with deoxyribonucleotides of the second strand. In one embodiment, the deoxyribonucleotides of the first strand that base pair with the deoxyribonucleotides of the second strand are consecutive deoxyribonucleotides. In another embodiment, two or more consecutive nucleotide residues of positions 24 to 27 of the first strand are deoxyribonucleotides that base pair with deoxyribonucleotides of the second strand. Optionally, each of positions 24 and 25 of the first strand is a deoxyribonucleotide that base pairs with a deoxyribonucleotide of the second strand. In a related embodiment, each nucleotide residue of positions 24 to 27 of the first oligonucleotide strand is a deoxyribonucleotide that base pairs with a deoxyribonucleotide of the second strand.

**[0009]** In one embodiment, the first strand is 29 to 49 nucleotides in length. In another embodiment, each nucleotide residue of positions 24 to 29 of the first oligonucleotide strand is a deoxyribonucleotide that base pairs with a deoxyribonucleotide of the second strand. In a further embodiment, the first strand is 31 to 49 nucleotides in length. Optionally, each nucleotide residue of positions 24 to 31 of the first oligonucleotide strand is a deoxyribonucleotide that base pairs with a deoxyribonucleotide of the second strand. In an additional embodiment, the first strand is 33 to 49 nucleotides in length. Optionally, each nucleotide residue of positions 24 to 33 of the first oligonucleotide strand is a deoxyribonucleotide that base pairs with a deoxyribonucleotide of the second strand. In another embodiment, the first strand is 35 to 49 nucleotides in length. Optionally, each nucleotide residue of positions 24 to 35 of the first oligonucleotide strand is a deoxyribonucleotide that base pairs with a deoxyribonucleotide of the second strand. In another embodiment, the first strand is 37 to 49 nucleotides in length. Optionally, each nucleotide residue of positions 24 to 37 of the first oligonucleotide strand is a deoxyribonucleotide that base pairs with a deoxyribonucleotide of the second strand.

**[0010]** In an additional embodiment, positions 24 to the 3' terminal nucleotide residue of the first strand include between one and 25 deoxyribonucleotide residues, and each of the deoxyribonucleotide residues of the first strand base pairs with a deoxyribonucleotide of the second strand.

**[0011]** In one embodiment, the deoxyribonucleotides of the second strand that base pair with the deoxyribonucleotides of the first strand are not complementary to the target RNA.

**[0012]** In another embodiment, the second strand possesses a 3' overhang of 1-4 nucleotides in length. Optionally, the 3' overhang is 1-3 nucleotides in length, or, as a further option, 1-2 nucleotides in length. In one embodiment, the nucleotides of the 3' overhang include a modified nucleotide. Optionally, the modified nucleotide residue is 2'-O-methyl, 2'-methoxyethoxy, 2'-fluoro, 2'-allyl, 2'-O-[2-(methylamino)-2-oxo-

ethyl], 4'-thio, 4'-CH<sub>2</sub>-O-2'-bridge, 4'-(CH<sub>2</sub>)<sub>2</sub>-O-2'-bridge, 2'-LNA, 2'-amino or 2'-O-(N-methylcarbamate). In one embodiment, the modified nucleotide of the 3' overhang is a 2'-O-methyl ribonucleotide. In a further embodiment, all nucleotides of the 3' overhang are modified nucleotides. In a further embodiment, the 3' overhang is two nucleotides in length and the modified nucleotide of the 3' overhang is a 2'-O-methyl modified ribonucleotide. In another embodiment, the second strand, starting from the nucleotide residue of the second strand that is complementary to the 5' terminal nucleotide residue of the first oligonucleotide strand, possesses unmodified nucleotide residues at all positions from position 20 to the 5' terminal residue of the second strand.

**[0013]** In another embodiment, one or both of the first and second strands includes a 5' phosphate.

**[0014]** In one embodiment, starting from the first nucleotide (position 1\*) at the 3' terminus of the first strand, position 1\*, 2\* and/or 3\* is a deoxyribonucleotide. In another embodiment, the first strand has a deoxyribonucleotide at position 1\* from the 3' terminus of the first strand. In a related embodiment, the first strand has deoxyribonucleotides at positions 1\* and 2\* from the 3' terminus of the first strand.

**[0015]** In another embodiment, the ultimate and penultimate residues of the 3' terminus of the first strand are deoxyribonucleotides and the ultimate and penultimate residues of the 5' terminus of the second strand are ribonucleotides.

**[0016]** In one embodiment, a nucleotide of the second or first oligonucleotide strand is substituted with a modified nucleotide that directs the orientation of Dicer cleavage. In an additional embodiment, starting from the first nucleotide (position 1) at the 3' terminus of the second strand, positions 1, 2, and 3 from the 3' terminus of the second strand are modified nucleotides.

**[0017]** In one embodiment, the first strand has a nucleotide sequence that is at least 80%, 90%, 95% or 100% complementary to the second strand nucleotide sequence.

**[0018]** In another embodiment, the 3' terminal nucleotide residue of the first strand is attached to the 5' terminal nucleotide residue of the second strand by a nucleotide sequence. In one embodiment, the nucleotide sequence that attaches the 3' terminal nucleotide residue of the first strand and the 5' terminal nucleotide residue of the second strand includes a tetraloop. In another embodiment, the nucleotide sequence that attaches the 3' terminal nucleotide residue of the first strand and the 5' terminal nucleotide residue of the second strand includes a hairpin.

**[0019]** In a further embodiment, the first and second strands are joined by a chemical linker. In a related embodiment, the 3' terminus of the first strand and the 5' terminus of the second strand are joined by a chemical linker.

**[0020]** In one embodiment, the dsNA is cleaved endogenously in a mammalian cell by Dicer. In another embodiment, the dsNA is cleaved endogenously in a mammalian cell to produce a double-stranded nucleic acid of 19-23 nucleotides in length that reduces target gene expression.

**[0021]** In an additional embodiment, the dsNA has a phosphate backbone modification that is a phosphonate, a phosphorothioate or a phosphotriester.

**[0022]** In a further embodiment, the dsNA reduces target gene expression in a mammalian cell in vitro by at least 10%, at least 50% or at least 80-90%.

**[0023]** In one embodiment, the dsNA, when introduced into a mammalian cell, reduces target gene expression in

comparison to a reference dsRNA that does not possess a deoxyribonucleotide-deoxyribonucleotide base pair.

**[0024]** In an additional embodiment, the dsNA, when introduced into a mammalian cell, reduces target gene expression by at least 70% when transfected into the cell at a concentration of 1 nM or less, 200 pM or less, 100 pM or less, 50 pM or less, 20 pM or less, or 10 pM or less.

**[0025]** In another embodiment, at least 50% of the ribonucleotide residues of the dsNA are unmodified ribonucleotides. In an additional embodiment, at least 50% of the ribonucleotide residues of the second strand are unmodified ribonucleotides.

**[0026]** In one embodiment, at least one of positions 24 to the 3' terminal nucleotide residue of the first strand that is a deoxyribonucleotide that base pairs with a deoxyribonucleotide of the second strand is an unmodified deoxyribonucleotide. In a related embodiment, both the at least one of positions 24 to the 3' terminal nucleotide residue of the first strand that is a deoxyribonucleotide that base pairs with a deoxyribonucleotide of the second strand and the deoxyribonucleotide of the second strand are unmodified deoxyribonucleotides. In another embodiment, at least 50% of all deoxyribonucleotides of the dsNA are unmodified deoxyribonucleotides.

**[0027]** In one embodiment, the second oligonucleotide strand, starting from the nucleotide residue of the second strand that is complementary to the 5' terminal nucleotide residue of the first oligonucleotide strand, includes alternating modified and unmodified nucleotide residues.

**[0028]** In certain embodiments, the target RNA is KRAS.

**[0029]** In another aspect, the invention provides an isolated double stranded nucleic acid (dsNA) having a first and a second oligonucleotide strand, where the first strand: is 27 nucleotide residues in length and the second strand is 27-31 nucleotide residues in length; starting from the first nucleotide (position 1) at the 5' terminus of the first strand, positions 1 to 23 of the first strand are ribonucleotides that base pair with ribonucleotides of the second strand to form a duplex; each of positions 24 to 27 of the first strand is a deoxyribonucleotide that base pairs with a deoxyribonucleotide of the second strand; the 3' terminus of the first strand and the 5' terminus of the second strand form a blunt end; and the second strand is sufficiently complementary to a target RNA along at least 19 ribonucleotides of the second strand length to reduce target gene expression when the double stranded nucleic acid is introduced into a mammalian cell.

**[0030]** In an additional aspect, the invention provides an isolated double stranded nucleic acid (dsNA) having a first oligonucleotide strand and a second oligonucleotide strand, where the first strand is 29 nucleotide residues in length and the second strand is 29-33 nucleotide residues in length, where starting from the first nucleotide (position 1) at the 5' terminus of the first strand, positions 1 to 23 of the first strand are ribonucleotides that base pair with ribonucleotides of the second strand to form a duplex; each of positions 24 to 29 of the first strand is a deoxyribonucleotide that base pairs with a deoxyribonucleotide of the second strand; the 3' terminus of the first strand and the 5' terminus of the second strand form a blunt end; and the second strand is sufficiently complementary to a target RNA along at least 19 ribonucleotides of the second strand length to reduce target gene expression when the double stranded nucleic acid is introduced into a mammalian cell.

**[0031]** In another aspect, the invention provides an isolated double stranded nucleic acid (dsNA) having a first oligonucleotide strand and a second oligonucleotide strand, where the first strand is 31 nucleotide residues in length and the second strand is 31-35 nucleotide residues in length, and starting from the first nucleotide (position 1) at the 5' terminus of the first strand, positions 1 to 23 of the first strand are ribonucleotides that base pair with ribonucleotides of the second strand to form a duplex; each of positions 24 to 31 of the first strand is a deoxyribonucleotide that base pairs with a deoxyribonucleotide of the second strand to form a duplex; the 3' terminus of the first strand and the 5' terminus of the second strand form a blunt end; and the second strand is sufficiently complementary to a target RNA along at least 19 ribonucleotides of the second strand length to reduce target gene expression when the double stranded nucleic acid is introduced into a mammalian cell.

**[0032]** In one aspect, the invention provides an isolated double stranded nucleic acid (dsNA) having a first oligonucleotide strand and a second oligonucleotide strand, where the first strand is 33 nucleotide residues in length and the second strand is 33-37 nucleotide residues in length, where starting from the first nucleotide (position 1) at the 5' terminus of the first strand, positions 1 to 23 of the first strand are ribonucleotides that base pair with ribonucleotides of the second strand to form a duplex; each of positions 24 to 33 of the first strand is a deoxyribonucleotide that base pairs with a deoxyribonucleotide of the second strand to form a duplex; the 3' terminus of the first strand and the 5' terminus of the second strand form a blunt end; and the second strand is sufficiently complementary to a target RNA along at least 19 ribonucleotides of the second strand length to reduce target gene expression when the double stranded nucleic acid is introduced into a mammalian cell.

**[0033]** In another aspect, the invention provides an isolated double stranded nucleic acid (dsNA) having a first oligonucleotide strand and a second oligonucleotide strand, where the first strand is 35 nucleotide residues in length and the second strand is 35-39 nucleotide residues in length, where starting from the first nucleotide (position 1) at the 5' terminus of the first strand, positions 1 to 23 of the first strand are ribonucleotides that base pair with ribonucleotides of the second strand to form a duplex; each of positions 24 to 35 of the first strand is a deoxyribonucleotide that base pairs with a deoxyribonucleotide of the second strand to form a duplex; the 3' terminus of the first strand and the 5' terminus of the second strand form a blunt end; and the second strand is sufficiently complementary to a target RNA along at least 19 ribonucleotides of the second strand length to reduce target gene expression when the double stranded nucleic acid is introduced into a mammalian cell.

**[0034]** In a further aspect, the invention provides an isolated double stranded nucleic acid (dsNA) having a first oligonucleotide strand and a second oligonucleotide strand, where the first strand is 37 nucleotide residues in length and the second strand is 37-41 nucleotide residues in length, where starting from the first nucleotide (position 1) at the 5' terminus of the first strand, positions 1 to 23 of the first strand are ribonucleotides that base pair with ribonucleotides of the second strand to form a duplex; each of positions 24 to 37 of the first strand is a deoxyribonucleotide that base pairs with a deoxyribonucleotide of the second strand to form a duplex; the 3' terminus of the first strand and the 5' terminus of the second strand form a blunt end; and the second strand is

sufficiently complementary to a target RNA along at least 19 ribonucleotides of the second strand length to reduce target gene expression when the double stranded nucleic acid is introduced into a mammalian cell.

**[0035]** In one embodiment, the deoxyribonucleotides of the second strand that base pair with the deoxyribonucleotides of the first strand are not complementary to the target RNA.

**[0036]** In one aspect, the invention provides an isolated double stranded nucleic acid (dsNA) having a first and a second oligonucleotide strand where the first strand: is 27 nucleotide residues in length, and starting from the first nucleotide (position 1) at the 5' terminus of the first strand, positions 1 to 23 of the first strand are ribonucleotides and positions 24 to 27 are deoxyribonucleotides; the second strand: is 29 nucleotide residues in length, starting from the first nucleotide (position 1) at the 5' terminus of the second strand, positions 1 to 4 of the second strand are deoxyribonucleotides, and the second strand includes 23 consecutive ribonucleotides that base pair with the ribonucleotides of positions 1 to 23 of the first strand to form a duplex; the 5' terminus of the first strand and the 3' terminus of the second strand form a 2 nucleotide 3' overhang structure; the 3' terminus of the first strand and the 5' terminus of the second strand form a blunt end; and the second strand is sufficiently complementary to a target RNA along at least 19 ribonucleotides of the second strand length to reduce target gene expression when the double stranded nucleic acid is introduced into a mammalian cell.

**[0037]** In one embodiment, the nucleotides of the 3' overhang are modified nucleotides. In another embodiment, starting from the first nucleotide (position 1) at the 5' terminus of the second strand, at least one of positions 13-27 is a modified ribonucleotide. In a further embodiment, starting from the first nucleotide (position 1) at the 5' terminus of the second strand, positions 13, 15, 17, 19, 21, 23, 25 and 27 are modified ribonucleotides.

**[0038]** In another aspect, the invention provides an isolated double stranded nucleic acid (dsNA) having a first and a second oligonucleotide strand, where the first strand is 27 to 49 nucleotide residues in length, and starting from the first nucleotide (position 1) at the 5' terminus of the first strand, positions 1 to 23 of the first strand are ribonucleotides; the second strand is 27 to 53 nucleotide residues in length and includes 23 consecutive ribonucleotides that base pair with the ribonucleotides of positions 1 to 23 of the first strand to form a duplex; the 5' terminus of the first strand and the 3' terminus of the second strand form a blunt end or 1-4 nucleotide overhang structure, the 3' terminus of the first strand and the 5' terminus of the second strand form a blunt end, and at least one of positions 24 to the 3' terminal nucleotide residue of the first strand is a phosphorothioate-modified nucleotide (PS-NA) that base pairs with a deoxyribonucleotide of the second strand, with the second strand being sufficiently complementary to a target RNA along at least 19 ribonucleotides of the second strand length to reduce target gene expression when the double stranded nucleic acid is introduced into a mammalian cell.

**[0039]** In one embodiment, two or more nucleotide residues of positions 24 to the 3' terminal nucleotide residue of the first strand are PS-NA residues that base pair with deoxyribonucleotides of the second strand. Optionally, four or more, six or more, eight or more, ten or more, twelve or more, or fifteen or more nucleotide residues of positions 24 to the 3' terminal nucleotide residue of the first strand are PS-NA

residues that base pair with deoxyribonucleotides of the second strand. In another embodiment, the deoxyribonucleotide of the second strand that base pairs with the PS-NA of the first strand is also a PS-NA.

**[0040]** In another aspect, the invention provides an isolated double stranded nucleic acid (dsNA) having a first strand and a second strand where the first strand is 27 to 49 nucleotide residues in length and starting from the first nucleotide (position 1) at the 5' terminus of the first strand, positions 1 to 23 of the first strand are ribonucleotides; the second strand is 27 to 53 nucleotide residues in length and includes 23 consecutive ribonucleotides that base pair with the ribonucleotides of positions 1 to 23 of the first strand to form a duplex; the 5' terminus of the first strand and the 3' terminus of the second strand form a structure that is either a blunt end or a 1-4 nucleotide 3' overhang; the 3' terminus of the first strand and the 5' terminus of the second strand form a blunt end; at least one nucleotide of the second strand base pairs with a deoxyribonucleotide of positions 24 to the 3' terminal nucleotide residue of the first strand and is a phosphorothioate-modified nucleotide (PS-NA); and the second strand is sufficiently complementary to a target RNA along at least 19 ribonucleotides of the second strand length to reduce target gene expression when the double stranded nucleic acid is introduced into a mammalian cell.

**[0041]** In one embodiment, two or more nucleotide residues of the second strand base pair with deoxyribonucleotides of positions 24 to the 3' terminal nucleotide residue of the first strand and are PS-NA residues. Optionally, four or more, six or more, eight or more, ten or more, twelve or more, or fifteen or more nucleotide residues of the second strand base pair with deoxyribonucleotides of positions 24 to the 3' terminal nucleotide residue of the first strand and are PS-NA residues. In another embodiment, the dsNA includes two or more, three or more, four or more, five or more, six or more, seven or more, eight or more, nine or more, ten or more, eleven or more, twelve or more, thirteen or more, fourteen or more, or fifteen or more total PS-NA residues.

**[0042]** In an additional aspect, the invention provides an isolated double stranded nucleic acid (dsNA) having a first and a second oligonucleotide strand, where the first strand is 27 to 49 nucleotide residues in length, and starting from the first nucleotide (position 1) at the 5' terminus of the first strand, positions 1 to 23 of the first strand are ribonucleotides; the second strand is 27 to 53 nucleotide residues in length and includes 23 consecutive ribonucleotides that base pair with the ribonucleotides of positions 1 to 23 of the first strand to form a duplex; the 5' terminus of the first strand and the 3' terminus of the second strand form a blunt end or 1-4 nucleotide overhang structure; the 3' terminus of the first strand and the 5' terminus of the second strand form a blunt end; and at least one of positions 24 to the 3' terminal nucleotide residue of the first strand is a deoxyribonucleotide that base pairs with a phosphorothioate-modified nucleotide (PS-NA) of the second strand, with the second strand being sufficiently complementary to a target RNA along at least 19 ribonucleotides of the second strand length to reduce target gene expression when the double stranded nucleic acid is introduced into a mammalian cell.

**[0043]** In one embodiment, two or more nucleotide residues of positions 24 to the 3' terminal nucleotide residue of the first strand are deoxyribonucleotides that base pair with PS-NA residues of the second strand. Optionally, four or more, six or more, eight or more, ten or more, twelve or more,



or fifteen or more nucleotide residues of positions 24 to the 3' terminal nucleotide residue of the first strand are deoxyribonucleotides that base pair with PS-NA residues of the second strand. In a further embodiment, the deoxyribonucleotide of the first strand that base pairs with the PS-NA of the second strand is also a PS-NA.

**[0044]** In another embodiment, the invention provides a method for reducing expression of a target gene in a cell involving contacting a cell with an isolated dsNA as described in an amount effective to reduce expression of a target gene in a cell in comparison to a reference dsRNA.

**[0045]** In an additional embodiment, the invention provides a method for reducing expression of a target gene in an animal that includes treating an animal with an isolated dsNA as described in an amount effective to reduce expression of a target gene in a cell of the animal in comparison to a reference dsRNA.

**[0046]** In one embodiment, the dsNA possesses enhanced pharmacokinetics when compared to an appropriate control DsiRNA. In another embodiment, the dsNA possesses enhanced pharmacodynamics when compared to an appropriate control DsiRNA. In an additional embodiment, the dsNA possesses reduced toxicity when compared to an appropriate control DsiRNA. In a further embodiment, the dsNA possesses enhanced intracellular uptake when compared to an appropriate control DsiRNA.

**[0047]** In a further embodiment, the invention provides a pharmaceutical composition that includes an isolated dsNA as described in an amount effective to reduce expression of a target gene in a cell in comparison to a reference dsRNA and a pharmaceutically acceptable carrier, for reducing expression of a target gene in a cell of a subject. In another embodiment, the invention provides a method of synthesizing dsNA as described, involving chemically or enzymatically synthesizing the dsNA. In an additional embodiment, the invention provides a kit that includes a dsNA as described, and instructions for its use.

**[0048]** In one aspect, the invention provides an isolated dsNA as shown in FIG. 30.

#### BRIEF DESCRIPTION OF THE DRAWINGS

**[0049]** FIG. 1A shows a schematic representation of the processing of a Dicer substrate inhibitory RNA agent ("DsiRNA"). The protein Dicer is represented by the large rectangle, with the PAZ (Piwi/Argonaute/Zwille) domain of Dicer also indicated. The PAZ domain binds the two-base overhang and the 3'-OH (hydroxyl group) at the 3' end of the guide (antisense) strand, and each strand of the dsRNA duplex is cleaved by separate RNase III domains (black triangles). Substitution of 2 bases of DNA for RNA at the 3' end of the passenger (sense) strand forms a two-base long RNA/DNA duplex blunt end, which reduces or eliminates binding affinity for PAZ. Cleavage of the DsiRNA typically yields a 19mer duplex with 2-base overhangs at each end.

**[0050]** FIG. 1B shows that the addition of four bases of DNA duplex to the DsiRNA had no apparent inhibitory effect upon Dicer cleavage. The bases inserted into this example of an anti-HPRT DsiRNA (heavy black bars and arrows) were not complementary to the HPRT target sequence.

**[0051]** FIG. 2A presents histogram data showing the robust efficacy of DsiRNA agents possessing base paired deoxyribonucleotides in a duplexed region located 3' of the Dicer cleavage site of the sense strand/5' of the Dicer cleavage site of the antisense strand ("Right-extended DsiRNA agents").

DsiRNA duplexes were transfected into HeLa cells at a fixed concentration of 20 nM, and HPRT expression levels were measured 24 hours later. Transfections were performed in duplicate, and each duplicate was assayed in triplicate for HPRT expression by qPCR. Error bars are the standard error. Duplex 1 targeted HPRT and was a 25/27mer configuration overhanging RNA/blunt two-DNA substitution as described in Rose et al. NAR 2005. All other duplexes were longer than Duplex 1 due to the insertion of bases that were not complementary to the HPRT target region. The length of the inserted sequence ranged from two bases (Duplex 2) to eight bases (Duplexes 6, 7, and 8).

**[0052]** FIG. 2B shows duplex numbers, sequences and chemical modification patterns for agents for which data is presented in FIG. 2A. UPPER case=unmodified RNA, Bold, underlined=2'-O-methyl RNA, lower case=DNA, bold lower case=phosphorothioate-modified DNA (PS-DNA). A general description of each duplex and the overall configuration is shown at right.

**[0053]** FIGS. 3A and 3B show that DNA-extended DsiRNA agents were more effective than corresponding RNA-extended DsiRNA agents at low concentrations. An optimized 27/29mer DsiRNA duplex targeting HPRT was compared to a modified duplex in a dose-response series at 10.0 nanomolar (nM), 1.0 nanomolar (nM) and 100 picomolar (100 pM or 0.1 nM), with efficacy of knockdown of HPRT mRNA levels assessed in HeLa cells. Duplex concentrations shown represent the final concentration of oligonucleotides in the transfection mixture and culture medium as described in the Examples. Duplex identities are indicated below the bars (1, 2, 3), with the "C" bar representing baseline HPRT expression in untreated cells. FIG. 3B shows the sequences and chemical modification patterns of those duplexes depicted in FIG. 3A. UPPER case=unmodified RNA, Bold, underlined=2'-O-methyl RNA, and lower case=DNA. DsiRNA 1 was a derivative of a previously reported active 25/27mer DsiRNA duplex (HPRT-1, Rose et al. NAR 2005, Collingwood et al. 2008, see also FIG. 2A above), but contained an insertion of two bases in each strand, which extended the oligonucleotide duplex to a 27/29mer (heavy black bars denote inserted base pairs). Duplex 2 was identical in sequence to duplex 1, but the two base pair insertion (heavy black bars), including two additional nucleosides of both passenger strand (sense sequence) and guide strand (antisense sequence) were synthesized as DNA. Thus, duplex 2 terminated in 4 DNA bp (base pairs) at the 5' end of the guide strand, in contrast to previously reported two base DNA substitutions at the 3' end of the passenger (sense) strand (Rose et al, 2005). Duplex 3 (mismatch (MM) control) was derived from the optimized HPRT-1 duplex, but synthesized with mismatches indicated by arrows. The base composition and chemical modification of each strand and the base sequences and overhang or blunt structure at the ends of duplex 3 were held constant relative to the optimized HPRT-1 duplex in order to control for non-targeted chemical effects (see FIG. 5 below).

**[0054]** FIGS. 4A-4D show that modified DsiRNA duplexes extended by two to eight base paired deoxyribonucleosides were more effective at reducing HPRT target mRNA levels than corresponding ribonucleoside-extended DsiRNA agents. FIG. 4A shows HPRT target gene mRNA levels for cells treated with 1 nM modified DsiRNA agents. FIG. 4B shows HPRT target gene mRNA levels for cells treated with 100 pM modified DsiRNA agents. FIG. 4C shows HPRT

target gene mRNA levels for cells treated with 10 pM modified DsiRNA agents. FIG. 4D shows the sequences and chemical modification patterns of those duplexes depicted in FIGS. 4A-4C. Inserted sequences (heavy bars beneath the duplexes) did not match the HPRT mRNA target region. UPPER case=unmodified RNA, Bold, underlined=2'-O-methyl RNA, lower case=DNA. U=untreated cells.

[0055] FIG. 5A shows HPRT target mRNA inhibition results for a series of modified duplexes of increasing length administered at a fixed concentration of 100 pM. FIG. 5B shows duplex numbers, sequences and chemical modification patterns for agents for which data is presented in FIG. 5A. Duplex 1 was an optimized 25/27mer DsiRNA containing chemical modifications, a two-base overhang at the 3'-end of the guide (antisense) strand and two DNA substitutions and a blunt end at the 3'-end of the passenger (sense) strand (Collingwood et al. 2008). Bases non-complementary to HPRT mRNA were inserted two bases at a time as either RNA (duplexes 2 through 5) or DNA (duplexes 6 through 9), increasing total duplex configurations from 27/29mers to 33/35mers. UPPER case=unmodified RNA, Bold, underlined=2'-O-methyl RNA, lower case=DNA. U=untreated cells. UPPER case=unmodified RNA, Bold, underlined=2'-O-methyl RNA, lower case=DNA.

[0056] FIG. 6 shows the structure and predicted Dicer-mediated processing of a "25/27mer DsiRNA" agent (top) and an exemplary "Left-extended" DsiRNA agent (bottom) which contains a mismatch residue (G:U) within the dsRNA duplex sequence. UPPER case=RNA residues; lower case=DNA residues.

[0057] FIG. 7 shows the structures of a series of DNA-extended duplexes, with pictured duplexes alternately right- or left-extended with 5 base pair DNA sequences. Mismatches are introduced within both forms of extended DsiRNA agents as indicated, with numbering of such mismatches proceeding in the 3' direction from position 1 of the second strand, which is the predicted 5' terminal RNA residue of the second strand after Dicer cleavage.

[0058] FIG. 8 depicts the results of an initial round of testing of the inhibitory activity of right- and left-extended agents shown in FIG. 7. For comparisons between right-versus left-extended parent molecules, right- versus left-extended agents harboring a mismatch at position 14, right-versus left-extended agents possessing a mismatch at position 16, and right- versus left-extended agents harboring a mismatch at both positions 14 and 18, left-extended agents were surprisingly observed to be more effective at gene silencing than corresponding right-extended agents. (100 pM of each indicated duplex was transfected into HeLa cells for all such experiments and % of KRAS target mRNA remaining was assessed at 24 hours.)

[0059] FIG. 9 depicts the result of a second round of experiments performed with the agents shown in FIG. 7, showing that left-extended agents were reproducibly more effective target mRNA silencing agents than right-extended agents in three of the four instances which were initially observed to show such a bias in favor of left-extended agents. Inhibitory results for a non-extended 25/27mer DsiRNA are also shown ("Opt" 25/27mer).

[0060] FIG. 10 shows the structure of a series of DsiRNA agents designed to silence an HPRT target mRNA, and inhibitory efficacies of such agents in cell culture. Capital letters indicate ribonucleotides; lower case letters indicate deoxyribonucleotides; bolded lower case letters indicate phospho-

rothioates (PS-NAs); bolded and underlined uppercase letters indicate 2'-O-methyl modified nucleotides; the bolded uppercase letter of agent DP1065P/DP1067G indicates the site of a mismatched nucleotide (with respect to the sense strand) within the "seed" region sequence of the antisense strand of the DsiRNA agent.

[0061] FIG. 11 shows that phosphorothioate modified "right-extended" DsiRNAs retain target HPRT1 gene inhibitory efficacy, and also indicates that passenger strand extended residues might tolerate phosphorothioate modification better than guide strand extended residues while retaining target gene inhibitory activity. In vitro Dicer cleavage assays (left lane=untreated; right lane=Dicer enzyme treated) are also shown for all extended DsiRNAs. Capital letters indicate ribonucleotides; lower case letters indicate deoxyribonucleotides, while bolded lower case letters indicate phosphorothioate-modified deoxyribonucleotides.

[0062] FIG. 12 depicts the structures of control and "right-extended" DsiRNAs of the invention targeting the "KRAS-200" site within the KRAS transcript. Capital letters indicate ribonucleotides; lower case letters indicate deoxyribonucleotides.

[0063] FIG. 13 shows the KRAS inhibitory efficacies observed for the DsiRNA structures of FIG. 12 in vitro.

[0064] FIG. 14 depicts the structures of control and "right-extended" DsiRNAs of the invention targeting the "KRAS-909" site within the KRAS transcript. Capital letters indicate ribonucleotides; lower case letters indicate deoxyribonucleotides.

[0065] FIG. 15 shows the KRAS inhibitory efficacies observed for the DsiRNA structures of FIG. 14 in vitro.

[0066] FIG. 16 depicts the structures of control and "right-extended" DsiRNAs of the invention targeting the "KRAS-249" site within the KRAS transcript, including modification patterns of such DsiRNAs. Capital letters indicate ribonucleotides; lower case letters indicate deoxyribonucleotides, while bolded lower case letters indicate phosphorothioate-modified deoxyribonucleotides. Underlined capital letters indicate 2'-O-methyl-modified ribonucleotides.

[0067] FIG. 17 depicts the structures of control and "right-extended" DsiRNAs of the invention targeting the "KRAS-516" site within the KRAS transcript, including modification patterns of such DsiRNAs. Capital letters indicate ribonucleotides; lower case letters indicate deoxyribonucleotides, while bolded lower case letters indicate phosphorothioate-modified deoxyribonucleotides. Underlined capital letters indicate 2'-O-methyl-modified ribonucleotides.

[0068] FIG. 18 depicts the structures of control and "right-extended" DsiRNAs of the invention targeting the "KRAS-909" site within the KRAS transcript, including modification patterns of such DsiRNAs. Capital letters indicate ribonucleotides; lower case letters indicate deoxyribonucleotides, while bolded lower case letters indicate phosphorothioate-modified deoxyribonucleotides. Underlined capital letters indicate 2'-O-methyl-modified ribonucleotides.

[0069] FIG. 19 shows in vitro KRAS inhibitory efficacy results obtained for the "right-extended" DsiRNAs of FIGS. 16-18. Results were obtained in HeLa cells contacted with the indicated DsiRNAs at 0.1 nM concentration, assayed at 24 hours post-RNAiMAX™ treatment. Capital letters indicate ribonucleotides; lower case letters indicate deoxyribonucleotides, while bolded lower case letters indicate phosphorothioate-modified deoxyribonucleotides.

**[0070]** FIG. 20 depicts the structures of 25/27mer “KRAS-249” site targeting DsiRNAs which were assessed for mismatch residue tolerance. Closed arrows indicate projected Dicer enzyme cleavage sites, while open arrow indicates projected Ago2 cleavage site within target strand sequence corresponding to passenger strand DsiRNA sequence shown. Capital letters indicate ribonucleotides; lower case letters indicate deoxyribonucleotides. Bolded capital letters indicate sites of target-mismatched residues of guide strand (and complementary residues of passenger strand, where applicable), with such target-mismatched residues obtained by “flipping” individual residues between guide and passenger strand during DsiRNA design. Horizontal bracket within DP1301P/DP1302G duplex indicates “seed region” of this duplex (with seed regions of all other DsiRNA structures occurring in the same vertically-aligned position).

**[0071]** FIG. 21 shows in vitro KRAS inhibitory efficacy results obtained for the DsiRNAs of FIG. 20. Results were obtained in HeLa cells contacted with the indicated DsiRNAs at 0.1 nM concentration, assayed at 24 hours post-RNAiMAX™ treatment.

**[0072]** FIG. 22 shows single dose (10 mg/kg) in vivo KRAS inhibitory efficacy results in liver tissue for an unmodified 25/27mer “KRAS-249” site targeting DsiRNA (“K249”), a 2'-O-methyl-modified form of this 25/27mer (“KRAS-249M”) and a DNA-extended form of this modified DsiRNA (“K249DNA”, shown in FIG. 16 as “K249D”; “5% Glu”=5% glucose control).

**[0073]** FIG. 23 shows single dose (10 mg/kg) in vivo KRAS inhibitory efficacy results in kidney tissue for an unmodified 25/27mer “KRAS-249” site targeting DsiRNA (“K249”), a 2'-O-methyl-modified form of this 25/27mer (“KRAS-249M”) and a DNA-extended form of this modified DsiRNA (“K249DNA”, shown in FIG. 16 as “K249D”; “5% Glu”=5% glucose control).

**[0074]** FIG. 24 shows single dose (10 mg/kg) in vivo KRAS inhibitory efficacy results in spleen tissue for an unmodified 25/27mer “KRAS-249” site targeting DsiRNA (“K249”), a 2'-O-methyl-modified form of this 25/27mer (“KRAS-249M”) and a DNA-extended form of this modified DsiRNA (“K249DNA”, shown in FIG. 16 as “K249D”; “5% Glu”=5% glucose control).

**[0075]** FIG. 25 shows single dose (10 mg/kg) in vivo KRAS inhibitory efficacy results in lymph node tissue for an unmodified 25/27mer “KRAS-249” site targeting DsiRNA (“K249”), a 2'-O-methyl-modified form of this 25/27mer (“KRAS-249M”) and a DNA-extended form of this modified DsiRNA (“K249DNA”, shown in FIG. 16 as “K249D”; “5% Glu”=5% glucose control).

**[0076]** FIG. 26 shows multi-dose (2 mg/kg, administered a total of four times, with each administration performed at three day intervals) in vivo KRAS inhibitory efficacy results in liver tissue for a 2'-O-methyl-modified form of a 25/27mer “KRAS-249” site targeting DsiRNA (“KRAS-249M”) and a DNA-extended form of this modified DsiRNA (“K249D”, as shown in FIG. 16).

**[0077]** FIG. 27 shows multi-dose (2 mg/kg, administered a total of four times, with each administration performed at three day intervals) in vivo KRAS inhibitory efficacy results in lung tissue for a 2'-O-methyl-modified form of a 25/27mer “KRAS-249” site targeting DsiRNA (“KRAS-249M”) and a DNA-extended form of this modified DsiRNA (“K249D”, as shown in FIG. 16).

**[0078]** FIG. 28 shows multi-dose (2 mg/kg, administered a total of four times, with each administration performed at three day intervals) in vivo KRAS inhibitory efficacy results in spleen tissue for a 2'-O-methyl-modified form of a 25/27mer “KRAS-249” site targeting DsiRNA (“KRAS-249M”) and a DNA-extended form of this modified DsiRNA (“K249D”, as shown in FIG. 16).

**[0079]** FIG. 29 shows multi-dose (2 mg/kg, administered a total of four times, with each administration performed at three day intervals) in vivo KRAS inhibitory efficacy results in kidney tissue for a 2'-O-methyl-modified form of a 25/27mer “KRAS-249” site targeting DsiRNA (“KRAS-249M”) and a DNA-extended form of this modified DsiRNA (“K249D”, as shown in FIG. 16).

**[0080]** FIG. 30 shows exemplary structures of “right extended” DsiRNA agents that form a blunt end between the 3' terminus of the first strand and 5' terminus of the second strand. Upper case letters indicate ribonucleotides; lower case characters denote deoxyribonucleotides; open triangle denotes a site within the sequence of the first strand (here, the sense strand) corresponding to the Ago2 cleavage site within the target RNA; filled triangles indicate projected sites of Dicer cleavage; and [#] denotes a duplex region of four to sixteen or more base pairs in length which comprises at least one deoxyribonucleotide-deoxyribonucleotide base pair. (In alternative embodiments, [#] indicates a duplex region of four to sixteen or more base pairs in length which comprises at least four deoxyribonucleotides but is not required to possess a deoxyribonucleotide-deoxyribonucleotide base pair.) Nucleotide position numbering is also shown.

**[0081]** FIG. 31 shows an exemplary structure of a “right extended” DsiRNA agent that possesses a 3'-terminal overhang of the first strand relative to the 5' terminus of the second strand. Upper case letters indicate ribonucleotides; lower case characters denote deoxyribonucleotides; open triangle denotes a site within the sequence of the first strand (here, the sense strand) corresponding to the Ago2 cleavage site within the target RNA; filled triangles indicate projected sites of Dicer cleavage; and [#] denotes a duplex region of four to sixteen or more base pairs in length which comprises at least one deoxyribonucleotide-deoxyribonucleotide base pair. (In alternative embodiments, [#] indicates a duplex region of four to sixteen or more base pairs in length which comprises at least four deoxyribonucleotides but is not required to possess a deoxyribonucleotide-deoxyribonucleotide base pair.) Nucleotide position numbering is also shown.

**[0082]** FIG. 32 shows an exemplary structure of a “right extended” DsiRNA agent that forms a fray at the 3'-terminus of the first strand and corresponding 5' terminus of the second strand. Upper case letters indicate ribonucleotides; lower case characters denote deoxyribonucleotides; open triangle denotes a site within the sequence of the first strand (here, the sense strand) corresponding to the Ago2 cleavage site within the target RNA; filled triangles indicate projected sites of Dicer cleavage; and [#] denotes a duplex region of four to sixteen or more base pairs in length which comprises at least one deoxyribonucleotide-deoxyribonucleotide base pair. (In alternative embodiments, [#] indicates a duplex region of four to sixteen or more base pairs in length which comprises at least four deoxyribonucleotides but is not required to possess a deoxyribonucleotide-deoxyribonucleotide base pair.) Nucleotide position numbering is also shown.

**[0083]** FIG. 33 shows exemplary structures of “right extended” DsiRNA agents that form a blunt end between the

3' terminus of the first strand and 5' terminus of the second strand, and that also possess mismatched residues within antisense strand sequences which are projected to be retained within the interference agent following Dicer cleavage. Upper case letters indicate ribonucleotides; lower case characters denote deoxyribonucleotides; open triangle denotes a site within the sequence of the first strand (here, the sense strand) corresponding to the Ago2 cleavage site within the target RNA; filled triangles indicate projected sites of Dicer cleavage; and [#] denotes a duplex region of four to sixteen or more base pairs in length which comprises at least one deoxyribonucleotide-deoxyribonucleotide base pair. (In alternative embodiments, [#] indicates a duplex region of four to sixteen or more base pairs in length which comprises at least four deoxyribonucleotides but is not required to possess a deoxyribonucleotide-deoxyribonucleotide base pair.) Seed and mismatch regions of the antisense strand, as well as nucleotide position numbering of each strand is also shown. The underlined antisense residue of the bottom agent indicates a nucleotide which base pairs with the sense strand of the DsiRNA agent, yet is projected to form a mismatch with the target RNA.

[0084] FIG. 34 shows exemplary structures of "right extended" DsiRNA agents that possess a 3'-terminal overhang of the first strand relative to the 5' terminus of the second strand, and that also possess mismatched residues within antisense strand sequences which are projected to be retained within the interference agent following Dicer cleavage. Upper case letters indicate ribonucleotides; lower case characters denote deoxyribonucleotides; open triangle denotes a site within the sequence of the first strand (here, the sense strand) corresponding to the Ago2 cleavage site within the target RNA; filled triangles indicate projected sites of Dicer cleavage; and [#] denotes a duplex region of four to sixteen or more base pairs in length which comprises at least one deoxyribonucleotide-deoxyribonucleotide base pair. (In alternative embodiments, [#] indicates a duplex region of four to sixteen or more base pairs in length which comprises at least four deoxyribonucleotides but is not required to possess a deoxyribonucleotide-deoxyribonucleotide base pair.) Seed and mismatch regions of the antisense strand, as well as nucleotide position numbering of each strand is also shown. The underlined antisense residue of the bottom agent indicates a nucleotide which base pairs with the sense strand of the DsiRNA agent, yet is projected to form a mismatch with the target RNA.

[0085] FIG. 35 shows exemplary structures of "right extended" DsiRNA agents that form a fray at the 3'-terminus of the first strand and corresponding 5' terminus of the second strand, and that also possess mismatched residues within antisense strand sequences which are projected to be retained within the interference agent following Dicer cleavage. Upper case letters indicate ribonucleotides; lower case characters denote deoxyribonucleotides; open triangle denotes a site within the sequence of the first strand (here, the sense strand) corresponding to the Ago2 cleavage site within the target RNA; filled triangles indicate projected sites of Dicer cleavage; and [#] denotes a duplex region of four to sixteen or more base pairs in length which comprises at least one deoxyribonucleotide-deoxyribonucleotide base pair. (In alternative embodiments, [#] indicates a duplex region of four to sixteen or more base pairs in length which comprises at least four deoxyribonucleotides but is not required to possess a deoxyribonucleotide-deoxyribonucleotide base pair.) Seed

and mismatch regions of the antisense strand, as well as nucleotide position numbering of each strand is also shown. The underlined antisense residue of the bottom agent indicates a nucleotide which base pairs with the sense strand of the DsiRNA agent, yet is projected to form a mismatch with the target RNA.

[0086] FIG. 36 shows exemplary structures of "left extended" DsiRNA agents that form a blunt end between the 3' terminus of the first strand and 5' terminus of the second strand. Upper case letters indicate ribonucleotides; lower case characters denote deoxyribonucleotides; open triangle denotes a site within the sequence of the first strand (here, the sense strand) corresponding to the Ago2 cleavage site within the target RNA; filled triangles indicate projected sites of Dicer cleavage; and [#] denotes a duplex region of four to sixteen or more base pairs in length which comprises at least one deoxyribonucleotide-deoxyribonucleotide base pair. (In alternative embodiments, [#] indicates a duplex region of four to sixteen or more base pairs in length which comprises at least four deoxyribonucleotides but is not required to possess a deoxyribonucleotide-deoxyribonucleotide base pair.) Nucleotide position numbering is also shown.

[0087] FIG. 37 shows exemplary structures of "left extended" DsiRNA agents that possess a 3'-terminal overhang of the first strand relative to the 5' terminus of the second strand. Upper case letters indicate ribonucleotides; lower case characters denote deoxyribonucleotides; open triangle denotes a site within the sequence of the first strand (here, the sense strand) corresponding to the Ago2 cleavage site within the target RNA; filled triangles indicate projected sites of Dicer cleavage; and [#] denotes a duplex region of four to sixteen or more base pairs in length which comprises at least one deoxyribonucleotide-deoxyribonucleotide base pair. (In alternative embodiments, [#] indicates a duplex region of four to sixteen or more base pairs in length which comprises at least four deoxyribonucleotides but is not required to possess a deoxyribonucleotide-deoxyribonucleotide base pair.) Nucleotide position numbering is also shown.

[0088] FIG. 38 shows an exemplary structure of a "left extended" DsiRNA agent that forms a fray at the 3'-terminus of the first strand and corresponding 5' terminus of the second strand. Upper case letters indicate ribonucleotides; lower case characters denote deoxyribonucleotides; open triangle denotes a site within the sequence of the first strand (here, the sense strand) corresponding to the Ago2 cleavage site within the target RNA; filled triangles indicate projected sites of Dicer cleavage; and [#] denotes a duplex region of four to sixteen or more base pairs in length which comprises at least one deoxyribonucleotide-deoxyribonucleotide base pair. (In alternative embodiments, [#] indicates a duplex region of four to sixteen or more base pairs in length which comprises at least four deoxyribonucleotides but is not required to possess a deoxyribonucleotide-deoxyribonucleotide base pair.) Nucleotide position numbering is also shown.

[0089] FIG. 39 shows exemplary structures of "left extended" DsiRNA agents that form a blunt end between the 3' terminus of the first strand and 5' terminus of the second strand, and that also possess mismatched residues within antisense strand sequences which are projected to be retained within the interference agent following Dicer cleavage. Upper case letters indicate ribonucleotides; lower case characters denote deoxyribonucleotides; open triangle denotes a site within the sequence of the first strand (here, the sense strand) corresponding to the Ago2 cleavage site within the

target RNA; filled triangles indicate projected sites of Dicer cleavage; and [#] denotes a duplex region of four to sixteen or more base pairs in length which comprises at least one deoxyribonucleotide-deoxyribonucleotide base pair. (In alternative embodiments, [#] indicates a duplex region of four to sixteen or more base pairs in length which comprises at least four deoxyribonucleotides but is not required to possess a deoxyribonucleotide-deoxyribonucleotide base pair.) Seed and mismatch regions of the antisense strand, as well as nucleotide position numbering of each strand is also shown. The underlined antisense residue of the lower two agents indicates a nucleotide which base pairs with the sense strand of the DsiRNA agent, yet is projected to form a mismatch with the target RNA.

**[0090]** FIG. 40 shows exemplary structures of “left extended” DsiRNA agents that possess a 3'-terminal overhang of the first strand relative to the 5' terminus of the second strand, and that also possess mismatched residues within antisense strand sequences which are projected to be retained within the interference agent following Dicer cleavage. Upper case letters indicate ribonucleotides; lower case characters denote deoxyribonucleotides; open triangle denotes a site within the sequence of the first strand (here, the sense strand) corresponding to the Ago2 cleavage site within the target RNA; filled triangles indicate projected sites of Dicer cleavage; and [#] denotes a duplex region of four to sixteen or more base pairs in length which comprises at least one deoxyribonucleotide-deoxyribonucleotide base pair. (In alternative embodiments, [#] indicates a duplex region of four to sixteen or more base pairs in length which comprises at least four deoxyribonucleotides but is not required to possess a deoxyribonucleotide-deoxyribonucleotide base pair.) Seed and mismatch regions of the antisense strand, as well as nucleotide position numbering of each strand is also shown. The underlined antisense residue of the middle agent indicates a nucleotide which base pairs with the sense strand of the DsiRNA agent, yet is projected to form a mismatch with the target RNA.

**[0091]** FIG. 41 shows exemplary structures of “left extended” DsiRNA agents that form a fray at the 3'-terminus of the first strand and corresponding 5' terminus of the second strand, and that also possess mismatched residues within antisense strand sequences which are projected to be retained within the interference agent following Dicer cleavage. Upper case letters indicate ribonucleotides; lower case characters denote deoxyribonucleotides; open triangle denotes a site within the sequence of the first strand (here, the sense strand) corresponding to the Ago2 cleavage site within the target RNA; filled triangles indicate projected sites of Dicer cleavage; and [#] denotes a duplex region of four to sixteen or more base pairs in length which comprises at least one deoxyribonucleotide-deoxyribonucleotide base pair. (In alternative embodiments, [#] indicates a duplex region of four to sixteen or more base pairs in length which comprises at least four deoxyribonucleotides but is not required to possess a deoxyribonucleotide-deoxyribonucleotide base pair.) Seed and mismatch regions of the antisense strand, as well as nucleotide position numbering of each strand is also shown. The underlined antisense residue of the bottom agent indicates a nucleotide which base pairs with the sense strand of the DsiRNA agent, yet is projected to form a mismatch with the target RNA.

**[0092]** FIGS. 42A-42C show exemplary structures of “right extended” DsiRNA agents. Upper case letters indicate

ribonucleotides; lower case characters denote deoxyribonucleotides; open triangle denotes a site within the sequence of the top strand (here, the sense strand) corresponding to the Ago2 cleavage site within the target RNA; filled triangles indicate projected sites of Dicer cleavage; and nucleotide position numbering is also shown.

**[0093]** FIGS. 43A-43C show exemplary structures of “left extended” DsiRNA agents. Upper case letters indicate ribonucleotides; lower case characters denote deoxyribonucleotides; open triangle denotes a site within the sequence of the top strand (here, the sense strand) corresponding to the Ago2 cleavage site within the target RNA; filled triangles indicate projected sites of Dicer cleavage; and nucleotide position numbering is also shown.

#### DETAILED DESCRIPTION

**[0094]** The invention provides compositions and methods for reducing expression of a target gene in a cell, involving contacting a cell with an isolated double stranded nucleic acid (dsNA) in an amount effective to reduce expression of a target gene in a cell. The dsNAs of the invention possess a pattern of deoxyribonucleotides (in most embodiments, the pattern comprises at least one deoxyribonucleotide-deoxyribonucleotide base pair) designed to direct the site of Dicer enzyme cleavage within the dsNA molecule. The deoxyribonucleotide pattern of the dsNA molecules of the invention is located within a region of the dsNA that can be excised via Dicer cleavage to generate an active siRNA agent that no longer contains the deoxyribonucleotide pattern (e.g., in most embodiments, the deoxyribonucleotide pattern comprises one or more deoxyribonucleotide-deoxyribonucleotide base pairs). Surprisingly, as demonstrated herein, DNA:DNA-extended Dicer-substrate siRNAs (DsiRNAs) were more effective RNA inhibitory agents than corresponding RNA:DNA- or RNA:RNA-extended DsiRNAs.

**[0095]** It was also surprising to discover that DsiRNAs comprising DNA:DNA extensions which were positioned at the 5' end of the first strand and corresponding 3' end of the second strand of a dsRNA DsiRNA agent (where the second strand is complementary to a sufficient region of target RNA sequence to serve as an effective guide strand sequence of an RNAi agent (antisense to the target RNA)) constituted effective—and in many instances enhanced—inhibitory agents.

**[0096]** The surprising discovery that DNA-extended DsiRNA agents do not exhibit decreases in efficacy as duplex length increases allows for the generation of DsiRNAs that remain effective while providing greater spacing for, e.g., attachment of DsiRNAs to additional and/or distinct functional groups, inclusion/patterning of stabilizing modifications (e.g., PS-NA moieties) or other forms of modifications capable of adding further functionality and/or enhancing, e.g., pharmacokinetics, pharmacodynamics or biodistribution of such agents, as compared to dsRNA agents of corresponding length that do not contain such double stranded DNA-extended domains.

**[0097]** The advantage provided by the newfound ability to lengthen DsiRNA-containing dsNA duplexes while retaining activity of a post-Dicer-processed siRNA agent at levels greater than dsRNA duplexes of similar length is emphasized by the results presented herein, which show that complete phosphorothioate (PS) modification of all nucleotides of a double-stranded DNA:DNA region of an extended DsiRNA agent completely abolished silencing activity (see duplex #8 of FIGS. 2A and 2B). The ability to extend DsiRNA agents

without observing a corresponding reduction in RNA silencing activity can also allow for inclusion of, e.g., more modified nucleotides within a single molecule that still retains RNA silencing activity than could otherwise be achieved were such modified nucleotides not allowed such spacing (in view of the inhibitory effect associated with certain modifications when present in a tandem series—e.g., tandem PS or 2'-O-methyl modifications). Similarly, the ability to include longer duplex extensions in such DsiRNA-containing agents while retaining RNA inhibitory function can also allow for certain functional groups to be attached to such agents that would otherwise not be possible, because of the ability of such functional groups to interfere with RNA silencing activity when present in tighter configurations.

#### DEFINITIONS

**[0098]** Unless defined otherwise, all technical and scientific terms used herein have the meaning commonly understood by a person skilled in the art to which this invention belongs. The following references provide one of skill with a general definition of many of the terms used in this invention: Singleton et al., *Dictionary of Microbiology and Molecular Biology* (2nd ed. 1994); *The Cambridge Dictionary of Science and Technology* (Walker ed., 1988); *The Glossary of Genetics*, 5th Ed., R. Rieger et al. (eds.), Springer Verlag (1991); and Hale & Marham, *The Harper Collins Dictionary of Biology* (1991). As used herein, the following terms have the meanings ascribed to them below, unless specified otherwise.

**[0099]** As used herein, the term “nucleic acid” refers to deoxyribonucleotides, ribonucleotides, or modified nucleotides, and polymers thereof in single- or double-stranded form. The term encompasses nucleic acids containing known nucleotide analogs or modified backbone residues or linkages, which are synthetic, naturally occurring, and non-naturally occurring, which have similar binding properties as the reference nucleic acid, and which are metabolized in a manner similar to the reference nucleotides. Examples of such analogs include, without limitation, phosphorothioates, phosphoramidates, methyl phosphonates, chiral-methyl phosphonates, 2-O-methyl ribonucleotides, peptide-nucleic acids (PNAs).

**[0100]** As used herein, “nucleotide” is used as recognized in the art to include those with natural bases (standard), and modified bases well known in the art. Such bases are generally located at the 1' position of a nucleotide sugar moiety. Nucleotides generally comprise a base, sugar and a phosphate group. The nucleotides can be unmodified or modified at the sugar, phosphate and/or base moiety, (also referred to interchangeably as nucleotide analogs, modified nucleotides, non-natural nucleotides, non-standard nucleotides and other; see, e.g., Usman and McSwiggen, *supra*; Eckstein, et al., *International PCT Publication No. WO 92/07065*; Usman et al., *International PCT Publication No. WO 93/15187*; Uhlman & Peyman, *supra*, all are hereby incorporated by reference herein). There are several examples of modified nucleic acid bases known in the art as summarized by Limbach, et al, *Nucleic Acids Res.* 22:2183, 1994. Some of the non-limiting examples of base modifications that can be introduced into nucleic acid molecules include, hypoxanthine, purine, pyridin-4-one, pyridin-2-one, phenyl, pseudouracil, 2,4,6-trimethoxy benzene, 3-methyl uracil, dihydrouridine, naphthyl, aminophenyl, 5-alkylcytidines (e.g., 5-methylcytidine), 5-alkyluridines (e.g., ribothymidine), 5-halouridine (e.g.,

5-bromouridine) or 6-azapyrimidines or 6-alkylpyrimidines (e.g. 6-methyluridine), propyne, and others (Burgin, et al., *Biochemistry* 35:14090, 1996; Uhlman & Peyman, *supra*). By “modified bases” in this aspect is meant nucleotide bases other than adenine, guanine, cytosine and uracil at 1' position or their equivalents.

**[0101]** As used herein, a “double-stranded nucleic acid” or “dsNA” is a molecule comprising two oligonucleotide strands which form a duplex. A dsNA may contain ribonucleotides, deoxyribonucleotides, modified nucleotides, and combinations thereof. The double-stranded NAs of the instant invention are substrates for proteins and protein complexes in the RNA interference pathway, e.g., Dicer and RISC. An exemplary structure of one form of dsNA of the invention is shown in FIG. 1A, and such structures characteristically comprise an RNA duplex in a region that is capable of functioning as a Dicer substrate siRNA (DsiRNA) and a DNA duplex comprising at least one deoxyribonucleotide, which is located at a position 3' of the projected Dicer cleavage site of the first strand of the DsiRNA/DNA agent, and is base paired with a cognate deoxyribonucleotide of the second strand, which is located at a position 5' of the projected Dicer cleavage site of the second strand of the DsiRNA/DNA agent. In alternative embodiments, the instant invention provides a structure that characteristically comprises an RNA duplex within a region that is capable of functioning as a Dicer substrate siRNA (DsiRNA) and a DNA duplex comprising at least one deoxyribonucleotide, which is located at a position 5' of the projected Dicer cleavage site of the first strand of the DsiRNA/DNA agent, and is base paired with a cognate deoxyribonucleotide of the second strand, which is located at a position 3' of the projected Dicer cleavage site of the second strand of the DsiRNA/DNA agent (see, e.g., “Left-Extended” DsiRNA agent of FIG. 6).

**[0102]** In certain embodiments, the DsiRNAs of the invention can possess deoxyribonucleotide residues at sites immediately adjacent to the projected Dicer enzyme cleavage site (s). For example, in the second, fourth and sixth DsiRNAs shown in FIG. 12, deoxyribonucleotides can be found (starting at the 5' terminal residue of the first strand as position 1) at position 22 and sites 3' of position 22 (e.g., 23, 24, 25, etc.). Correspondingly, deoxyribonucleotides can also be found on the second strand commencing at the nucleotide that is complementary to position 20 of the first strand, and also at positions on the second strand that are located in the 5' direction of this nucleotide. Thus, certain effective DsiRNAs of the invention possess only 19 duplexed ribonucleotides prior to commencement of introduction of deoxyribonucleotides within the first strand, second strand, and/or both strands of such DsiRNAs. While the preceding statements regarding placement of deoxyribonucleotides immediately adjacent to a projected Dicer enzyme cleavage site of the DsiRNAs of the invention explicitly contemplates “right-extended” DsiRNAs of the invention, parallel placement of deoxyribonucleotides can be performed within “left-extended” DsiRNAs of the invention (e.g., deoxyribonucleotides can be placed immediately adjacent to the projected Dicer enzyme cleavage site within “left-extended” DsiRNAs—e.g., immediately 5' on the sense strand of the most 5' projected Dicer cleavage site on the sense strand of such a “left-extended” DsiRNA and/or immediately 3' on the antisense strand of the most 3' projected Dicer cleavage site on the antisense strand of such a “left-extended” DsiRNA).

**[0103]** As used herein, “duplex” refers to a double helical structure formed by the interaction of two single stranded nucleic acids. According to the present invention, a duplex may contain first and second strands which are sense and antisense, or which are target and antisense. A duplex is typically formed by the pairwise hydrogen bonding of bases, i.e., “base pairing”, between two single stranded nucleic acids which are oriented antiparallel with respect to each other. Base pairing in duplexes generally occurs by Watson-Crick base pairing, e.g., guanine (G) forms a base pair with cytosine (C) in DNA and RNA (thus, the cognate nucleotide of a guanine deoxyribonucleotide is a cytosine deoxyribonucleotide, and vice versa), adenine (A) forms a base pair with thymine (T) in DNA, and adenine (A) forms a base pair with uracil (U) in RNA. Conditions under which base pairs can form include physiological or biologically relevant conditions (e.g., intracellular: pH 7.2, 140 mM potassium ion; extracellular pH 7.4, 145 mM sodium ion). Furthermore, duplexes are stabilized by stacking interactions between adjacent nucleotides. As used herein, a duplex may be established or maintained by base pairing or by stacking interactions. A duplex is formed by two complementary nucleic acid strands, which may be substantially complementary or fully complementary (see below).

**[0104]** By “complementary” or “complementarity” is meant that a nucleic acid can form hydrogen bond(s) with another nucleic acid sequence by either traditional Watson-Crick or Hoogsteen base pairing. In reference to the nucleic acid molecules of the present disclosure, the binding free energy for a nucleic acid molecule with its complementary sequence is sufficient to allow the relevant function of the nucleic acid to proceed, e.g., RNAi activity. Determination of binding free energies for nucleic acid molecules is well known in the art (see, e.g., Turner, et al., CSH Symp. Quant. Biol. LII, pp. 123-133, 1987; Frier, et al., Proc. Nat. Acad. Sci. USA 83:9373-9377, 1986; Turner, et al., J. Am. Chem. Soc. 109:3783-3785, 1987). A percent complementarity indicates the percentage of contiguous residues in a nucleic acid molecule that can form hydrogen bonds (e.g., Watson-Crick base pairing) with a second nucleic acid sequence (e.g., 5, 6, 7, 8, 9, or 10 nucleotides out of a total of 10 nucleotides in the first oligonucleotide being based paired to a second nucleic acid sequence having 10 nucleotides represents 50%, 60%, 70%, 80%, 90%, and 100% complementary, respectively). To determine that a percent complementarity is of at least a certain percentage, the percentage of contiguous residues in a nucleic acid molecule that can form hydrogen bonds (e.g., Watson-Crick base pairing) with a second nucleic acid sequence is calculated and rounded to the nearest whole number (e.g., 12, 13, 14, 15, 16, or 17 nucleotides out of a total of 23 nucleotides in the first oligonucleotide being based paired to a second nucleic acid sequence having 23 nucleotides represents 52%, 57%, 61%, 65%, 70%, and 74%, respectively; and has at least 50%, 50%, 60%, 60%, 70%, and 70% complementarity, respectively). As used herein, “substantially complementary” refers to complementarity between the strands such that they are capable of hybridizing under biological conditions. Substantially complementary sequences have 60%, 70%, 80%, 90%, 95%, or even 100% complementarity. Additionally, techniques to determine if two strands are capable of hybridizing under biological conditions by examining their nucleotide sequences are well known in the art.

**[0105]** The first and second strands of the agents of the invention (antisense and sense oligonucleotides) are not

required to be completely complementary. In one embodiment, the RNA sequence of the antisense strand contains one or more mismatches or modified nucleotides with base analogs. In an exemplary embodiment, such mismatches occur within the 3' region of RNA sequence of the antisense strand (e.g., within the RNA sequence of the antisense strand that is complementary to the target RNA sequence that is positioned 5' of the projected Argonaute 2 (Ago2) cut site within the target RNA—see, e.g., FIG. 6 for illustration of exemplary location of such a mismatch-containing region). In one aspect, about two mismatches or modified nucleotides with base analogs are incorporated within the RNA sequence of the antisense strand that is 3' in the antisense strand of the projected Ago2 cleavage site of the target RNA sequence when the target RNA sequence is hybridized.

**[0106]** The use of mismatches or decreased thermodynamic stability (specifically at or near the 3'-terminal residues of sense/5'-terminal residues of the antisense region of siRNAs) has been proposed to facilitate or favor entry of the antisense strand into RISC (Schwarz et al., 2003; Khvorova et al., 2003), presumably by affecting some rate-limiting unwinding steps that occur with entry of the siRNA into RISC. Thus, terminal base composition has been included in design algorithms for selecting active 21mer siRNA duplexes (Ui-Tei et al., 2004; Reynolds et al., 2004).

**[0107]** In certain embodiments, mismatches (or modified nucleotides with base analogs) can be positioned within a parent DsiRNA (optionally a right- or left-extended DsiRNA agent) at or near the predicted 3'-terminus of the sense strand of the siRNA projected to be formed following Dicer cleavage. In such embodiments, the small end-terminal sequence which contains the mismatch(es) will either be left unpaired with the antisense strand (become part of a 3'-overhang) or be cleaved entirely off the final 21-mer siRNA. In such embodiments, mismatches in the original (non-Dicer-processed) agent do not persist as mismatches in the final RNA component of RISC. It has been found that base mismatches or destabilization of segments at the 3'-end of the sense strand of Dicer substrate improved the potency of synthetic duplexes in RNAi, presumably by facilitating processing by Dicer (Collingwood et al., 2008).

**[0108]** In some embodiments, one or more mismatches are positioned within a DsiRNA agent of the invention (optionally a right- or left-extended DsiRNA agent) at a location within the region of the antisense strand of the DsiRNA agent that hybridizes with the region of the target mRNA that is positioned 5' of the predicted Ago2 cleavage site within the target mRNA (see, e.g., location(s) of mismatches within the agents of FIG. 7). Optionally, two or more mismatches are positioned within the right- or left-extended DsiRNA agents of the instant invention within this relatively 3' region of the antisense strand that hybridizes to a sequence of the target RNA that is positioned 5' of the projected Ago2 cleavage site of the target RNA (were target RNA cleavage to occur). Inclusion of such mismatches within the DsiRNA agents of the instant invention can allow such agents to exert inhibitory effects that resemble those of naturally-occurring miRNAs, and optionally can be directed against not only naturally-occurring miRNA target RNAs (e.g., 3' UTR regions of target transcripts) but also against RNA sequences for which no naturally-occurring antagonistic miRNA is known to exist. For example, DsiRNAs of the invention possessing mismatched base pairs which are designed to resemble and/or function as miRNAs can be synthesized to target repetitive



sequences within genes/transcripts that might not be targeted by naturally-occurring miRNAs (e.g., repeat sequences within the Notch protein can be targeted, where individual repeats within Notch can differ from one another (e.g., be degenerate) at the nucleic acid level, but which can be effectively targeted via a miRNA mechanism that allows for mismatch(es) yet also allows for a more promiscuous inhibitory effect than a corresponding, perfect match siRNA agent). In such embodiments, target RNA cleavage may or may not be necessary for the mismatch-containing DsiRNA agent to exert an inhibitory effect.

**[0109]** In one embodiment, a double stranded nucleic acid molecule of the invention comprises or functions as a microRNA (miRNA). By “microRNA” or “miRNA” is meant a small double stranded RNA that regulates the expression of target messenger RNAs either by mRNA cleavage, translational repression/inhibition or heterochromatic silencing (see for example Ambros, 2004, *Nature*, 431, 350-355; Bartel, 2004, *Cell*, 116, 281-297; Cullen, 2004, *Virus Research.*, 102, 3-9; He et al., 2004, *Nat. Rev. Genet.*, 5, 522-531; and Ying et al., 2004, *Gene*, 342, 25-28). In one embodiment, the microRNA of the invention, has partial complementarity (i.e.,

**[0111]** Hybridization is measured by the temperature required to dissociate single stranded nucleic acids forming a duplex, i.e., (the melting temperature;  $T_m$ ). Hybridization conditions are also conditions under which base pairs can form. Various conditions of stringency can be used to determine hybridization (see, e.g., Wahl, G. M. and S. L. Berger (1987) *Methods Enzymol.* 152:399; Kimmel, A. R. (1987) *Methods Enzymol.* 152:507). Stringent temperature conditions will ordinarily include temperatures of at least about 30° C., more preferably of at least about 37° C., and most preferably of at least about 42° C. The hybridization temperature for hybrids anticipated to be less than 50 base pairs in length should be 5-10° C. less than the melting temperature ( $T_m$ ) of the hybrid, where  $T_m$  is determined according to the following equations. For hybrids less than 18 base pairs in length,  $T_m(^{\circ}\text{C.})=2(\# \text{ of A+T bases})+4(\# \text{ of G+C bases})$ . For hybrids between 18 and 49 base pairs in length,  $T_m(^{\circ}\text{C.})=81.5+16.6(\log 10[\text{Na}^+])+0.41(\% \text{ G+C})-(600/\text{N})$ , where N is the number of bases in the hybrid, and  $[\text{Na}^+]$  is the concentration of sodium ions in the hybridization buffer ( $[\text{Na}^+]$  for  $1 \times \text{SSC}=0.165 \text{ M}$ ). For example, a hybridization determination buffer is shown in Table 1.

TABLE 1

	final conc.	Vender	Cat#	Lot#	m.w./ Stock	To make 50 mL solution
NaCl	100 mM	Sigma	S-5150	41K8934	5M	1 mL
KCl	80 mM	Sigma	P-9541	70K0002	74.55	0.298 g
MgCl <sub>2</sub>	8 mM	Sigma	M-1028	120K8933	1M	0.4 mL
sucrose	2% w/v	Fisher	BP220-212	907105	342.3	1 g
Tris-HCl	16 mM	Fisher	BP1757-500	12419	1M	0.8 mL
NaH <sub>2</sub> PO <sub>4</sub>	1 mM	Sigma	S-3193	52H-029515	120.0	0.006 g
EDTA	0.02 mM	Sigma	E-7889	110K89271	0.5M	2 μL
H <sub>2</sub> O		Sigma	W-4502	51K2359		to 50 mL
pH = 7.0 at 20° C.				adjust with HCl		

less than 100% complementarity) between the sense strand (e.g., first strand) or sense region and the antisense strand (e.g., second strand) or antisense region of the miRNA molecule or between the antisense strand or antisense region of the miRNA and a corresponding target nucleic acid molecule (e.g., target mRNA). For example, partial complementarity can include various mismatches or non-base paired nucleotides (e.g., 1, 2, 3, 4, 5 or more mismatches or non-based paired nucleotides, such as nucleotide bulges) within the double stranded nucleic acid molecule structure, which can result in bulges, loops, or overhangs that result between the sense strand or sense region and the antisense strand or antisense region of the miRNA or between the antisense strand or antisense region of the miRNA and a corresponding target nucleic acid molecule.

**[0110]** Single-stranded nucleic acids that base pair over a number of bases are said to “hybridize.” Hybridization is typically determined under physiological or biologically relevant conditions (e.g., intracellular: pH 7.2, 140 mM potassium ion; extracellular pH 7.4, 145 mM sodium ion). Hybridization conditions generally contain a monovalent cation and biologically acceptable buffer and may or may not contain a divalent cation, complex anions, e.g. gluconate from potassium gluconate, uncharged species such as sucrose, and inert polymers to reduce the activity of water in the sample, e.g. PEG. Such conditions include conditions under which base pairs can form.

**[0112]** Useful variations on hybridization conditions will be readily apparent to those skilled in the art. Hybridization techniques are well known to those skilled in the art and are described, for example, in Benton and Davis (*Science* 196: 180, 1977); Grunstein and Hogness (*Proc. Natl. Acad. Sci., USA* 72:3961, 1975); Ausubel et al. (*Current Protocols in Molecular Biology*, Wiley Interscience, New York, 2001); Berger and Kimmel (*Antisense to Molecular Cloning Techniques*, 1987, Academic Press, New York); and Sambrook et al., *Molecular Cloning: A Laboratory Manual*, Cold Spring Harbor Laboratory Press, New York.

**[0113]** As used herein, “oligonucleotide strand” is a single stranded nucleic acid molecule. An oligonucleotide may comprise ribonucleotides, deoxyribonucleotides, modified nucleotides (e.g., nucleotides with 2' modifications, synthetic base analogs, etc.) or combinations thereof. Such modified oligonucleotides can be preferred over native forms because of properties such as, for example, enhanced cellular uptake and increased stability in the presence of nucleases.

**[0114]** Certain dsNAs of this invention are chimeric dsNAs. “Chimeric dsNAs” or “chimeras”, in the context of this invention, are dsNAs which contain two or more chemically distinct regions, each made up of at least one nucleotide. These dsNAs typically contain at least one region primarily comprising ribonucleotides (optionally including modified ribonucleotides) that form a Dicer substrate siRNA (“DsiRNA”) molecule. This DsiRNA region is covalently attached to a



second region comprising base paired deoxyribonucleotides (a “dsDNA region”) which confers one or more beneficial properties (such as, for example, increased efficacy, e.g., increased potency and/or duration of DsiRNA activity, function as a recognition domain or means of targeting a chimeric dsDNA to a specific location, for example, when administered to cells in culture or to a subject, functioning as an extended region for improved attachment of functional groups, payloads, detection/detectable moieties, functioning as an extended region that allows for more desirable modifications and/or improved spacing of such modifications, etc.). This second region comprising base paired deoxyribonucleotides may also include modified or synthetic nucleotides and/or modified or synthetic deoxyribonucleotides.

**[0115]** As used herein, the term “ribonucleotide” encompasses natural and synthetic, unmodified and modified ribonucleotides. Modifications include changes to the sugar moiety, to the base moiety and/or to the linkages between ribonucleotides in the oligonucleotide. As used herein, the term “ribonucleotide” specifically excludes a deoxyribonucleotide, which is a nucleotide possessing a single proton group at the 2' ribose ring position.

**[0116]** As used herein, the term “deoxyribonucleotide” encompasses natural and synthetic, unmodified and modified deoxyribonucleotides. Modifications include changes to the sugar moiety, to the base moiety and/or to the linkages between deoxyribonucleotide in the oligonucleotide. As used herein, the term “deoxyribonucleotide” also includes a modified ribonucleotide that does not permit Dicer cleavage of a dsDNA agent, e.g., a 2'-O-methyl ribonucleotide, a phosphorothioate-modified ribonucleotide residue, etc., that does not permit Dicer cleavage to occur at a bond of such a residue.

**[0117]** As used herein, the term “PS-NA” refers to a phosphorothioate-modified nucleotide residue. The term “PS-NA” therefore encompasses both phosphorothioate-modified ribonucleotides (“PS-RNAs”) and phosphorothioate-modified deoxyribonucleotides (“PS-DNAs”).

**[0118]** In certain embodiments, a chimeric DsiRNA/DNA agent of the invention comprises at least one duplex region of at least 23 nucleotides in length, within which at least 50% of all nucleotides are unmodified ribonucleotides. As used herein, the term “unmodified ribonucleotide” refers to a ribonucleotide possessing a hydroxyl (—OH) group at the 2' position of the ribose sugar.

**[0119]** In certain embodiments, a chimeric DsiRNA/DNA agent of the invention comprises at least one region, located 3' of the projected Dicer cleavage site on the first strand and 5' of the projected Dicer cleavage site on the second strand, having a length of at least 2 base paired nucleotides in length, wherein at least 50% of all nucleotides within this region of at least 2 base paired nucleotides in length are unmodified deoxyribonucleotides. As used herein, the term “unmodified deoxyribonucleotide” refers to a ribonucleotide possessing a single proton at the 2' position of the ribose sugar.

**[0120]** As used herein, “antisense strand” refers to a single stranded nucleic acid molecule which has a sequence complementary to that of a target RNA. When the antisense strand contains modified nucleotides with base analogs, it is not necessarily complementary over its entire length, but must at least hybridize with a target RNA.

**[0121]** As used herein, “sense strand” refers to a single stranded nucleic acid molecule which has a sequence complementary to that of an antisense strand. When the antisense strand contains modified nucleotides with base analogs, the

sense strand need not be complementary over the entire length of the antisense strand, but must at least duplex with the antisense strand.

**[0122]** As used herein, “guide strand” refers to a single stranded nucleic acid molecule of a dsRNA or dsRNA-containing molecule, which has a sequence sufficiently complementary to that of a target RNA to result in RNA interference. After cleavage of the dsRNA or dsRNA-containing molecule by Dicer, a fragment of the guide strand remains associated with RISC, binds a target RNA as a component of the RISC complex, and promotes cleavage of a target RNA by RISC. As used herein, the guide strand does not necessarily refer to a continuous single stranded nucleic acid and may comprise a discontinuity, preferably at a site that is cleaved by Dicer. A guide strand is an antisense strand.

**[0123]** As used herein, “target RNA” refers to an RNA that would be subject to modulation guided by the antisense strand, such as targeted cleavage or steric blockage. The target RNA could be, for example genomic viral RNA, mRNA, a pre-mRNA, or a non-coding RNA. The preferred target is mRNA, such as the mRNA encoding a disease associated protein, such as ApoB, Bcl2, Hif-1 alpha, Survivin or a p21 ras, such as Ha. ras, K-ras or N-ras.

**[0124]** As used herein, “passenger strand” refers to an oligonucleotide strand of a dsRNA or dsRNA-containing molecule, which has a sequence that is complementary to that of the guide strand. As used herein, the passenger strand does not necessarily refer to a continuous single stranded nucleic acid and may comprise a discontinuity, preferably at a site that is cleaved by Dicer. A passenger strand is a sense strand.

**[0125]** As used herein, “Dicer” refers to an endoribonuclease in the RNase III family that cleaves a dsRNA or dsRNA-containing molecule, e.g., double-stranded RNA (dsRNA) or pre-microRNA (miRNA), into double-stranded nucleic acid fragments about 19-25 nucleotides long, usually with a two-base overhang on the 3' end. With respect to the dsNAs of the invention, the duplex formed by a dsRNA region of a dsDNA of the invention is recognized by Dicer and is a Dicer substrate on at least one strand of the duplex. Dicer catalyzes the first step in the RNA interference pathway, which consequently results in the degradation of a target RNA. The protein sequence of human Dicer is provided at the NCBI database under accession number NP\_085124, hereby incorporated by reference.

**[0126]** Dicer “cleavage” is determined as follows (e.g., see Collingwood et al., *Oligonucleotides* 18:187-200 (2008)). In a Dicer cleavage assay, RNA duplexes (100 pmol) are incubated in 20  $\mu$ L of 20 mM Tris pH 8.0, 200 mM NaCl, 2.5 mM MgCl<sub>2</sub> with or without 1 unit of recombinant human Dicer (Stratagene, La Jolla, Calif.) at 37° C. for 18-24 hours. Samples are desalted using a Performa SR 96-well plate (Edge Biosystems, Gaithersburg, Md.). Electrospray-ionization liquid chromatography mass spectroscopy (ESI-LCMS) of duplex RNAs pre- and post-treatment with Dicer is done using an Oligo HTCS system (Novatia, Princeton, N.J.; Hail et al., 2004), which consists of a ThermoFinnigan TSQ7000, Xcalibur data system, ProMass data processing software and Paradigm MS4 HPLC (Michrom BioResources, Auburn, Calif.). In this assay, Dicer cleavage occurs where at least 5%, 10%, 20%, 30%, 40%, 50%, 60%, 70%, 80%, 90%, 95%, or even 100% of the Dicer substrate dsRNA, (i.e., 25-35 bp dsRNA, preferably 26-30 bp dsRNA, optionally extended as described herein) is cleaved to a shorter dsRNA (e.g., 19-23 bp dsRNA, preferably, 21-23 bp dsRNA).

[0127] As used herein, “Dicer cleavage site” refers to the sites at which Dicer cleaves a dsRNA (e.g., the dsRNA region of a dsNA of the invention). Dicer contains two RNase III domains which typically cleave both the sense and antisense strands of a dsRNA. The average distance between the RNase III domains and the PAZ domain determines the length of the short double-stranded nucleic acid fragments it produces and this distance can vary (Macrae I, et al. (2006). “Structural basis for double-stranded RNA processing by Dicer”. *Science* 311 (5758): 195-8.). As shown in FIG. 1A, Dicer is projected to cleave certain double-stranded nucleic acids of the instant invention that possess an antisense strand having a 2 nucleotide 3' overhang at a site between the 21<sup>st</sup> and 22<sup>nd</sup> nucleotides removed from the 3' terminus of the antisense strand, and at a corresponding site between the 21<sup>st</sup> and 22<sup>nd</sup> nucleotides removed from the 5' terminus of the sense strand. The projected and/or prevalent Dicer cleavage site(s) for dsNA molecules distinct from those depicted in FIG. 1A may be similarly identified via art-recognized methods, including those described in Macrae et al. While the Dicer cleavage event depicted in FIG. 1A generates a 21 nucleotide siRNA, it is noted that Dicer cleavage of a dsNA (e.g., DsiRNA) can result in generation of Dicer-processed siRNA lengths of 19 to 23 nucleotides in length. Indeed, in one aspect of the invention that is described in greater detail below, a double stranded DNA region is included within a dsNA for purpose of directing prevalent Dicer excision of a typically non-preferred 19mer siRNA.

[0128] As used herein, “overhang” refers to unpaired nucleotides, in the context of a duplex having two or four free ends at either the 5' terminus or 3' terminus of a dsNA. In certain embodiments, the overhang is a 3' or 5' overhang on the antisense strand or sense strand.

[0129] As used herein, “target” refers to any nucleic acid sequence whose expression or activity is to be modulated. In particular embodiments, the target refers to an RNA which duplexes to a single stranded nucleic acid that is an antisense strand in a RISC complex. Hybridization of the target RNA to the antisense strand results in processing by the RISC complex. Consequently, expression of the RNA or proteins encoded by the RNA, e.g., mRNA, is reduced.

[0130] As used herein, the term “RNA processing” refers to processing activities performed by components of the siRNA, miRNA or RNase H pathways (e.g., Drosha, Dicer, Argonaute2 or other RISC endoribonucleases, and RNaseH), which are described in greater detail below (see “RNA Processing” section below). The term is explicitly distinguished from the post-transcriptional processes of 5' capping of RNA and degradation of RNA via non-RISC- or non-RNase H-mediated processes. Such “degradation” of an RNA can take several forms, e.g. deadenylation (removal of a 3' poly(A) tail), and/or nuclease digestion of part or all of the body of the RNA by any of several endo- or exo-nucleases (e.g., RNase III, RNase P, RNase T1, RNase A (1, 2, 3, 4/5), oligonucleotidase, etc.).

[0131] As used herein, “reference” is meant a standard or control. As is apparent to one skilled in the art, an appropriate reference is where only one element is changed in order to determine the effect of the one element.

[0132] As used herein, “modified nucleotide” refers to a nucleotide that has one or more modifications to the nucleoside, the nucleobase, pentose ring, or phosphate group. For example, modified nucleotides exclude ribonucleotides containing adenosine monophosphate, guanosine monophos-

phate, uridine monophosphate, and cytidine monophosphate and deoxyribonucleotides containing deoxyadenosine monophosphate, deoxyguanosine monophosphate, deoxythymidine monophosphate, and deoxycytidine monophosphate. Modifications include those naturally occurring that result from modification by enzymes that modify nucleotides, such as methyltransferases. Modified nucleotides also include synthetic or non-naturally occurring nucleotides. Synthetic or non-naturally occurring modifications in nucleotides include those with 2' modifications, e.g., 2'-methoxyethoxy, 2'-fluoro, 2'-allyl, 2'-O-[2-(methylamino)-2-oxoethyl], 4'-thio, 4'-CH<sub>2</sub>-O-2'-bridge, 4'-(CH<sub>2</sub>)<sub>2</sub>-O-2'-bridge, 2'-LNA, and 2'-O—(N-methylcarbamate) or those comprising base analogs. In connection with 2'-modified nucleotides as described for the present disclosure, by “amino” is meant 2'-NH<sub>2</sub> or 2'-O—NH<sub>2</sub>, which can be modified or unmodified. Such modified groups are described, e.g., in Eckstein et al., U.S. Pat. No. 5,672,695 and Matulic-Adamic et al., U.S. Pat. No. 6,248,878.

[0133] The term “in vitro” has its art recognized meaning, e.g., involving purified reagents or extracts, e.g., cell extracts. The term “in vivo” also has its art recognized meaning, e.g., involving living cells, e.g., immortalized cells, primary cells, cell lines, and/or cells in an organism.

[0134] In reference to the nucleic acid molecules of the present disclosure, the modifications may exist in patterns on a strand of the dsNA. As used herein, “alternating positions” refers to a pattern where every other nucleotide is a modified nucleotide or there is an unmodified nucleotide (e.g., an unmodified ribonucleotide) between every modified nucleotide over a defined length of a strand of the dsNA (e.g., 5'-MNMMMN-3'; 3'-MNMMMN-5'; where M is a modified nucleotide and N is an unmodified nucleotide). The modification pattern starts from the first nucleotide position at either the 5' or 3' terminus according to any of the position numbering conventions described herein (in certain embodiments, position 1 is designated in reference to the terminal residue of a strand following a projected Dicer cleavage event of a DsiRNA agent of the invention; thus, position 1 does not always constitute a 3' terminal or 5' terminal residue of a pre-processed agent of the invention). The pattern of modified nucleotides at alternating positions may run the full length of the strand, but in certain embodiments includes at least 4, 6, 8, 10, 12, 14 nucleotides containing at least 2, 3, 4, 5, 6 or 7 modified nucleotides, respectively. As used herein, “alternating pairs of positions” refers to a pattern where two consecutive modified nucleotides are separated by two consecutive unmodified nucleotides over a defined length of a strand of the dsNA (e.g., 5'-MMNMMNMMNMMN-3'; 3'-MMNMMNMMNMMN-5'; where M is a modified nucleotide and N is an unmodified nucleotide). The modification pattern starts from the first nucleotide position at either the 5' or 3' terminus according to any of the position numbering conventions described herein. The pattern of modified nucleotides at alternating positions may run the full length of the strand, but preferably includes at least 8, 12, 16, 20, 24, 28 nucleotides containing at least 4, 6, 8, 10, 12 or 14 modified nucleotides, respectively. It is emphasized that the above modification patterns are exemplary and are not intended as limitations on the scope of the invention.

[0135] As used herein, “base analog” refers to a heterocyclic moiety which is located at the 1' position of a nucleotide sugar moiety in a modified nucleotide that can be incorporated into a nucleic acid duplex (or the equivalent position in

a nucleotide sugar moiety substitution that can be incorporated into a nucleic acid duplex). In the dsNAs of the invention, a base analog is generally either a purine or pyrimidine base excluding the common bases guanine (G), cytosine (C), adenine (A), thymine (T), and uracil (U). Base analogs can duplex with other bases or base analogs in dsRNAs. Base analogs include those useful in the compounds and methods of the invention, e.g., those disclosed in U.S. Pat. Nos. 5,432,272 and 6,001,983 to Benner and US Patent Publication No. 20080213891 to Manoharan, which are herein incorporated by reference. Non-limiting examples of bases include hypoxanthine (I), xanthine (X), 3 $\beta$ -D-ribofuranosyl-(2,6-diaminopyrimidine) (K), 3- $\beta$ -D-ribofuranosyl-(1-methyl-pyrazolo [4,3-d]pyrimidine-5,7(4H,6H)-dione) (P), iso-cytosine (iso-C), iso-guanine (iso-G), 1- $\beta$ -D-ribofuranosyl-(5-nitroindole), 1- $\beta$ -D-ribofuranosyl-(3-nitropyrrole), 5-bromouracil, 2-aminopurine, 4-thio-dT, 7-(2-thienyl)-imidazo[4,5-b]pyridine (Ds) and pyrrole-2-carbaldehyde (Pa), 2-amino-6-(2-thienyl)purine (S), 2-oxopyridine (Y), difluorotolyl, 4-fluoro-6-methylbenzimidazole, 4-methylbenzimidazole, 3-methyl isocarbostyrylyl, 5-methyl isocarbostyrylyl, and 3-methyl-7-propynyl isocarbostyrylyl, 7-azaindolyl, 6-methyl-7-azaindolyl, imidizopyridinyl, 9-methyl-imidizopyridinyl, pyrrolopyridinyl, isocarbostyrylyl, 7-propynyl isocarbostyrylyl, propynyl-7-azaindolyl, 2,4,5-trimethylphenyl, 4-methylindolyl, 4,6-dimethylindolyl, phenyl, naphthalenyl, anthracenyl, phenanthracenyl, pyrenyl, stilbenzyl, tetracenyl, pentacenyl, and structural derivatives thereof (Schweitzer et al., *J. Org. Chem.*, 59:7238-7242 (1994); Berger et al., *Nucleic Acids Research*, 28(15):2911-2914 (2000); Moran et al., *J. Am. Chem. Soc.*, 119:2056-2057 (1997); Morales et al., *J. Am. Chem. Soc.*, 121:2323-2324 (1999); Guckian et al., *J. Am. Chem. Soc.*, 118:8182-8183 (1996); Morales et al., *J. Am. Chem. Soc.*, 122(6):1001-1007 (2000); McMinn et al., *J. Am. Chem. Soc.*, 121:11585-11586 (1999); Guckian et al., *J. Org. Chem.*, 63:9652-9656 (1998); Moran et al., *Proc. Natl. Acad. Sci.*, 94:10506-10511 (1997); Das et al., *J. Chem. Soc., Perkin Trans.*, 1:197-206 (2002); Shibata et al., *J. Chem. Soc., Perkin Trans.*, 1: 1605-1611 (2001); Wu et al., *J. Am. Chem. Soc.*, 122(32):7621-7632 (2000); O'Neill et al., *J. Org. Chem.*, 67:5869-5875 (2002); Chaudhuri et al., *J. Am. Chem. Soc.*, 117:10434-10442 (1995); and U.S. Pat. No. 6,218,108.). Base analogs may also be a universal base.

**[0136]** As used herein, "universal base" refers to a heterocyclic moiety located at the 1' position of a nucleotide sugar moiety in a modified nucleotide, or the equivalent position in a nucleotide sugar moiety substitution, that, when present in a nucleic acid duplex, can be positioned opposite more than one type of base without altering the double helical structure (e.g., the structure of the phosphate backbone). Additionally, the universal base does not destroy the ability of the single stranded nucleic acid in which it resides to duplex to a target nucleic acid. The ability of a single stranded nucleic acid containing a universal base to duplex a target nucleic acid can be assayed by methods apparent to one in the art (e.g., UV absorbance, circular dichroism, gel shift, single stranded nuclease sensitivity, etc.). Additionally, conditions under which duplex formation is observed may be varied to determine duplex stability or formation, e.g., temperature, as melting temperature ( $T_m$ ) correlates with the stability of nucleic acid duplexes. Compared to a reference single stranded nucleic acid that is exactly complementary to a target nucleic acid, the single stranded nucleic acid containing a universal

base forms a duplex with the target nucleic acid that has a lower  $T_m$  than a duplex formed with the complementary nucleic acid. However, compared to a reference single stranded nucleic acid in which the universal base has been replaced with a base to generate a single mismatch, the single stranded nucleic acid containing the universal base forms a duplex with the target nucleic acid that has a higher  $T_m$  than a duplex formed with the nucleic acid having the mismatched base.

**[0137]** Some universal bases are capable of base pairing by forming hydrogen bonds between the universal base and all of the bases guanine (G), cytosine (C), adenine (A), thymine (T), and uracil (U) under base pair forming conditions. A universal base is not a base that forms a base pair with only one single complementary base. In a duplex, a universal base may form no hydrogen bonds, one hydrogen bond, or more than one hydrogen bond with each of G, C, A, T, and U opposite to it on the opposite strand of a duplex. Preferably, the universal bases does not interact with the base opposite to it on the opposite strand of a duplex. In a duplex, base pairing between a universal base occurs without altering the double helical structure of the phosphate backbone. A universal base may also interact with bases in adjacent nucleotides on the same nucleic acid strand by stacking interactions. Such stacking interactions stabilize the duplex, especially in situations where the universal base does not form any hydrogen bonds with the base positioned opposite to it on the opposite strand of the duplex. Non-limiting examples of universal-binding nucleotides include inosine, 1- $\beta$ -D-ribofuranosyl-5-nitroindole, and/or 1- $\beta$ -D-ribofuranosyl-3-nitropyrrole (US Pat. Appl. Publ. No. 20070254362 to Quay et al.; Van Aerschot et al., An acyclic 5-nitroindazole nucleoside analogue as ambiguous nucleoside. *Nucleic Acids Res.* 1995 Nov. 11; 23(21):4363-70; Loakes et al., 3-Nitropyrrole and 5-nitroindole as universal bases in primers for DNA sequencing and PCR. *Nucleic Acids Res.* 1995 Jul. 11; 23(13):2361-6; Loakes and Brown, 5-Nitroindole as an universal base analogue. *Nucleic Acids Res.* 1994 Oct. 11; 22(20):4039-43).

**[0138]** As used herein, "loop" refers to a structure formed by a single strand of a nucleic acid, in which complementary regions that flank a particular single stranded nucleotide region hybridize in a way that the single stranded nucleotide region between the complementary regions is excluded from duplex formation or Watson-Crick base pairing. A loop is a single stranded nucleotide region of any length. Examples of loops include the unpaired nucleotides present in such structures as hairpins, stem loops, or extended loops.

**[0139]** As used herein, "extended loop" in the context of a dsRNA refers to a single stranded loop and in addition 1, 2, 3, 4, 5, 6 or up to 20 base pairs or duplexes flanking the loop. In an extended loop, nucleotides that flank the loop on the 5' side form a duplex with nucleotides that flank the loop on the 3' side. An extended loop may form a hairpin or stem loop.

**[0140]** As used herein, "tetraloop" in the context of a dsRNA refers to a loop (a single stranded region) consisting of four nucleotides that forms a stable secondary structure that contributes to the stability of an adjacent Watson-Crick hybridized nucleotides. Without being limited to theory, a tetraloop may stabilize an adjacent Watson-Crick base pair by stacking interactions. In addition, interactions among the four nucleotides in a tetraloop include but are not limited to non-Watson-Crick base pairing, stacking interactions, hydrogen bonding, and contact interactions (Cheong et al., *Nature* 1990 Aug. 16; 346(6285):680-2; Heus and Pardi, *Science* 1991 Jul.

12; 253(5016):191-4). A tetraloop confers an increase in the melting temperature ( $T_m$ ) of an adjacent duplex that is higher than expected from a simple model loop sequence consisting of four random bases. For example, a tetraloop can confer a melting temperature of at least 55° C. in 10 mM NaHPO<sub>4</sub> to a hairpin comprising a duplex of at least 2 base pairs in length. A tetraloop may contain ribonucleotides, deoxyribonucleotides, modified nucleotides, and combinations thereof. Examples of RNA tetraloops include the UNCG family of tetraloops (e.g., UUCG), the GNRA family of tetraloops (e.g., GAAA), and the CUUG tetraloop. (Woese et al., Proc Natl Acad Sci USA. 1990 November; 87(21):8467-71; Antao et al., Nucleic Acids Res. 1991 Nov. 11; 19(21):5901-5). Examples of DNA tetraloops include the d(GNNA) family of tetraloops (e.g., d(GTTA), the d(GNRA)) family of tetraloops, the d(GNAB) family of tetraloops, the d(CNNG) family of tetraloops, the d(TNCG) family of tetraloops (e.g., d(TTCG)). (Nakano et al. Biochemistry, 41 (48), 14281-14292, 2002.; SHINJI et al. Nippon Kagakkai Koen Yokoshu VOL. 78th; NO. 2; PAGE. 731 (2000).)

**[0141]** As used herein, “increase” or “enhance” is meant to alter positively by at least 5% compared to a reference in an assay. An alteration may be by 5%, 10%, 25%, 30%, 50%, 75%, or even by 100% compared to a reference in an assay. By “enhance Dicer cleavage,” it is meant that the processing of a quantity of a dsRNA or dsRNA-containing molecule by Dicer results in more Dicer cleaved dsRNA products, that Dicer cleavage reaction occurs more quickly compared to the processing of the same quantity of a reference dsRNA or dsRNA-containing molecule in an in vivo or in vitro assay of this disclosure, or that Dicer cleavage is directed to cleave at a specific, preferred site within a dsNA and/or generate higher prevalence of a preferred population of cleavage products (e.g., by inclusion of DNA residues as described herein). In one embodiment, enhanced or increased Dicer cleavage of a dsNA molecule is above the level of that observed with an appropriate reference dsNA molecule. In another embodiment, enhanced or increased Dicer cleavage of a dsNA molecule is above the level of that observed with an inactive or attenuated molecule.

**[0142]** As used herein “reduce” is meant to alter negatively by at least 5% compared to a reference in an assay. An alteration may be by 5%, 10%, 25%, 30%, 50%, 75%, or even by 100% compared to a reference in an assay. By “reduce expression,” it is meant that the expression of the gene, or level of RNA molecules or equivalent RNA molecules encoding one or more proteins or protein subunits, or level or activity of one or more proteins or protein subunits encoded by a target gene, is reduced below that observed in the absence of the nucleic acid molecules (e.g., dsRNA molecule or dsRNA-containing molecule) in an in vivo or in vitro assay of this disclosure. In one embodiment, inhibition, down-regulation or reduction with a dsNA molecule is below that level observed in the presence of an inactive or attenuated molecule. In another embodiment, inhibition, down-regulation, or reduction with dsNA molecules is below that level observed in the presence of, e.g., a dsNA molecule with scrambled sequence or with mismatches. In another embodiment, inhibition, down-regulation, or reduction of gene expression with a nucleic acid molecule of the instant disclosure is greater in the presence of the nucleic acid molecule than in its absence.

**[0143]** As used herein, “cell” is meant to include both prokaryotic (e.g., bacterial) and eukaryotic (e.g., mammalian or plant) cells. Cells may be of somatic or germ line origin,

may be totipotent or pluripotent, and may be dividing or non-dividing. Cells can also be derived from or can comprise a gamete or an embryo, a stem cell, or a fully differentiated cell. Thus, the term “cell” is meant to retain its usual biological meaning and can be present in any organism such as, for example, a bird, a plant, and a mammal, including, for example, a human, a cow, a sheep, an ape, a monkey, a pig, a dog, and a cat. Within certain aspects, the term “cell” refers specifically to mammalian cells, such as human cells, that contain one or more isolated dsNA molecules of the present disclosure. In particular aspects, a cell processes dsRNAs or dsRNA-containing molecules resulting in RNA interference of target nucleic acids, and contains proteins and protein complexes required for RNAi, e.g., Dicer and RISC.

**[0144]** As used herein, “animal” is meant a multicellular, eukaryotic organism, including a mammal, particularly a human. The methods of the invention in general comprise administration of an effective amount of the agents herein, such as an agent of the structures of formulae herein, to a subject (e.g., animal, human) in need thereof, including a mammal, particularly a human. Such treatment will be suitably administered to subjects, particularly humans, suffering from, having, susceptible to, or at risk for a disease, or a symptom thereof.

**[0145]** By “pharmaceutically acceptable carrier” is meant, a composition or formulation that allows for the effective distribution of the nucleic acid molecules of the instant disclosure in the physical location most suitable for their desired activity.

**[0146]** The present invention is directed to compositions that comprise both a double stranded RNA (“dsRNA”) duplex and DNA-containing extended region—in most embodiments, a dsDNA duplex—within the same agent, and methods for preparing them, that are capable of reducing the expression of target genes in eukaryotic cells. One of the strands of the dsRNA region contains a region of nucleotide sequence that has a length that ranges from about 15 to about 22 nucleotides that can direct the destruction of the RNA transcribed from the target gene. The dsDNA duplex region of such an agent is not necessarily complementary to the target RNA, and, therefore, in such instances does not enhance target RNA hybridization of the region of nucleotide sequence capable of directing destruction of a target RNA. Double stranded NAs of the invention can possess strands that are chemically linked, or can also possess an extended loop, optionally comprising a tetraloop, that links the first and second strands. In some embodiments, the extended loop containing the tetraloop is at the 3' terminus of the sense strand, at the 5' terminus of the antisense strand, or both.

**[0147]** In one embodiment, the dsNA of the invention comprises a double stranded RNA duplex region comprising 18-30 nts (for example, 18, 19, 20, 21, 22, 23, 24, 25, 26, 27, 28, 29 and 30 nts) in length.

**[0148]** The DsiRNA/dsDNA agents of the instant invention can enhance the following attributes of such agents relative to DsiRNAs lacking such dsDNA regions: in vitro efficacy (e.g., potency and duration of effect), in vivo efficacy (e.g., potency, duration of effect, pharmacokinetics, pharmacodynamics, intracellular uptake, reduced toxicity). In certain embodiments, the dsDNA region of the instant invention can optionally provide an additional agent (or fragment thereof), such as an aptamer or fragment thereof; a binding site (e.g., a “decoy” binding site) for a native or exogenously introduced moiety capable of binding to dsDNA in either a non-sequence-selective

tive or sequence-specific manner (e.g., the dsDNA-extended region of an agent of the instant invention can be designed to comprise one or more transcription factor recognition sequences and/or the dsDNA-extended region can provide a sequence-specific recognition domain for a probe, marker, etc.).

**[0149]** As used herein, the term “pharmacokinetics” refers to the process by which a drug is absorbed, distributed, metabolized, and eliminated by the body. In certain embodiments of the instant invention, enhanced pharmacokinetics of a DsiRNA/dsDNA agent relative to an appropriate control DsiRNA refers to increased absorption and/or distribution of such an agent, and/or slowed metabolism and/or elimination of such a DsiRNA/dsDNA agent from a subject administered such an agent.

**[0150]** As used herein, the term “pharmacodynamics” refers to the action or effect of a drug on a living organism. In certain embodiments of the instant invention, enhanced pharmacodynamics of a DsiRNA/dsDNA agent relative to an appropriate control DsiRNA refers to an increased (e.g., more potent or more prolonged) action or effect of a DsiRNA/dsDNA agent upon a subject administered such agent, relative to an appropriate control DsiRNA.

**[0151]** As used herein, the term “stabilization” refers to a state of enhanced persistence of an agent in a selected environment (e.g., in a cell or organism). In certain embodiments, the DsiRNA/dsDNA chimeric agents of the instant invention exhibit enhanced stability relative to appropriate control DsiRNAs. Such enhanced stability can be achieved via enhanced resistance of such agents to degrading enzymes (e.g., nucleases) or other agents.

#### DsiRNA Design/Synthesis

**[0152]** It was previously shown that longer dsRNA species of from 25 to about 30 nucleotides (DsiRNAs) yield unexpectedly effective RNA inhibitory results in terms of potency and duration of action, as compared to 19-23mer siRNA agents. Without wishing to be bound by the underlying theory of the dsRNA processing mechanism, it is thought that the longer dsRNA species serve as a substrate for the Dicer enzyme in the cytoplasm of a cell. In addition to cleaving the dsNA of the invention into shorter segments, Dicer is thought to facilitate the incorporation of a single-stranded cleavage product derived from the cleaved dsNA into the RISC complex that is responsible for the destruction of the cytoplasmic RNA of or derived from the target gene. Prior studies (Rossi et al., U.S. Patent Application No. 2007/0265220) have shown that the cleavability of a dsRNA species (specifically, a DsiRNA agent) by Dicer corresponds with increased potency and duration of action of the dsRNA species. The instant invention, at least in part, provides for design of RNA inhibitory agents that direct the site of Dicer cleavage, such that preferred species of Dicer cleavage products are thereby generated.

**[0153]** A model of DsiRNA processing is presented in FIG. 1A. Briefly, Dicer enzyme binds to a DsiRNA agent, resulting in cleavage of the DsiRNA at a position 19-23 nucleotides removed from a Dicer PAZ domain-associated 3' overhang sequence of the antisense strand of the DsiRNA agent. This

Dicer cleavage event results in excision of those duplexed nucleic acids previously located at the 3' end of the passenger (sense) strand and 5' end of the guide (antisense) strand. (Cleavage of the DsiRNA shown in FIG. 1A typically yields a 19mer duplex with 2-base overhangs at each end.) As presently modeled in FIG. 1A, this Dicer cleavage event generates a 21-23 nucleotide guide (antisense) strand capable of directing sequence-specific inhibition of target mRNA as a RISC component.

**[0154]** The first and second oligonucleotides of the DsiRNA agents of the instant invention are not required to be completely complementary. In fact, in one embodiment, the 3'-terminus of the sense strand contains one or more mismatches. In one aspect, about two mismatches are incorporated at the 3' terminus of the sense strand. In another embodiment, the DsiRNA of the invention is a double stranded RNA molecule containing two RNA oligonucleotides each of which is an identical number of nucleotides in the range of 27-35 nucleotides in length and, when annealed to each other, have blunt ends and a two nucleotide mismatch on the 3'-terminus of the sense strand (the 5'-terminus of the antisense strand). The use of mismatches or decreased thermodynamic stability (specifically at the 3'-sense/5'-antisense position) has been proposed to facilitate or favor entry of the antisense strand into RISC (Schwarz et al., 2003; Khvorova et al., 2003), presumably by affecting some rate-limiting unwinding steps that occur with entry of the siRNA into RISC. Thus, terminal base composition has been included in design algorithms for selecting active 21mer siRNA duplexes (Ui-Tei et al., 2004; Reynolds et al., 2004). With Dicer cleavage of the dsRNA region of this embodiment, the small end-terminal sequence which contains the mismatches will either be left unpaired with the antisense strand (become part of a 3'-overhang) or be cleaved entirely off the final 21-mer siRNA. These specific forms of “mismatches”, therefore, do not persist as mismatches in the final RNA component of RISC. The finding that base mismatches or destabilization of segments at the 3'-end of the sense strand of Dicer substrate improved the potency of synthetic duplexes in RNAi, presumably by facilitating processing by Dicer, was a surprising finding of past works describing the design and use of 25-30mer dsRNAs (also termed “DsiRNAs” herein; Rossi et al., U.S. Patent Application Nos. 2005/0277610, 2005/0244858 and 2007/0265220). It is now equally surprising that DsiRNAs having base-paired deoxyribonucleotides at either passenger (sense) or guide (antisense) strand positions that are predicted to be 3' of the most 3' Dicer cleavage site of the respective passenger or guide strand are at least equally effective as RNA-RNA duplex-extended DsiRNA agents. Such agents may also harbor mismatches, with such mismatches being formed by the antisense strand either in reference to (actual or projected hybridation with) the sequence of the sense strand of the DsiRNA agent, or in reference to the target RNA sequence. Exemplary mismatched or wobble base pairs of agents possessing mismatches are G:A, C:A, C:U, G:G, A:A, C:C, U:U, I:A, I:U and I:C. Base pair strength of such agents can also be lessened via modification of the nucleotides of such agents, including, e.g., 2-amino- or 2,6-diamino modifications of guanine and adenine nucleotides.

#### Exemplary Structures of DsiRNA Agent Compositions

**[0155]** In one aspect, the present invention provides compositions for RNA interference (RNAi) that possess one or more base paired deoxyribonucleotides within a region of a

double stranded nucleic acid (dsNA) that is positioned 3' of a projected sense strand Dicer cleavage site and correspondingly 5' of a projected antisense strand Dicer cleavage site. The compositions of the invention comprise a dsNA which is a precursor molecule, i.e., the dsNA of the present invention is processed in vivo to produce an active small interfering nucleic acid (siRNA). The dsNA is processed by Dicer to an active siRNA which is incorporated into RISC.

**[0156]** In certain embodiments, the DsiRNA agents of the invention can have any of the following exemplary structures:

**[0157]** In one such embodiment, the DsiRNA comprises:

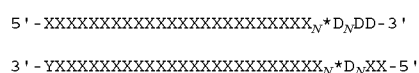

wherein “X”=RNA, “Y” is an optional overhang domain comprised of 0-10 RNA monomers that are optionally 2'-O-methyl RNA monomers—in certain embodiments, “Y” is an overhang domain comprised of 1-4 RNA monomers that are optionally 2'-O-methyl RNA monomers, “D”=DNA, and “N”=1 to 50 or more, but is optionally 1-15 or, optionally, 1-8. “N\*”=0 to 15 or more, but is optionally 0, 1, 2, 3, 4, 5 or 6. In one embodiment, the top strand is the sense strand, and the bottom strand is the antisense strand. Alternatively, the bottom strand is the sense strand and the top strand is the antisense strand.

**[0158]** In a related embodiment, the DsiRNA comprises:

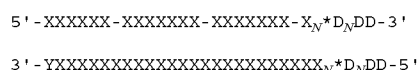

wherein “X”=RNA, “Y” is an optional overhang domain comprised of 0-10 RNA monomers that are optionally 2'-O-methyl RNA monomers—in certain embodiments, “Y” is an overhang domain comprised of 1-4 RNA monomers that are optionally 2'-O-methyl RNA monomers, “D”=DNA, and “N”=1 to 50 or more, but is optionally 1-15 or, optionally, 1-8. “N\*”=0 to 15 or more, but is optionally 0, 1, 2, 3, 4, 5 or 6. In one embodiment, the top strand is the sense strand, and the bottom strand is the antisense strand. Alternatively, the bottom strand is the sense strand and the top strand is the antisense strand.

**[0159]** In another such embodiment, the DsiRNA comprises:

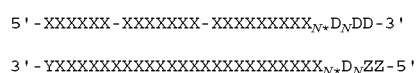

wherein “X”=RNA, “X”=2'-O-methyl RNA, “Y” is an optional overhang domain comprised of 0-10 RNA monomers that are optionally 2'-O-methyl RNA monomers—in certain embodiments, “Y” is an overhang domain comprised of 1-4 RNA monomers that are optionally 2'-O-methyl RNA monomers, “D”=DNA, “Z”=DNA or RNA, and “N”=1 to 50 or more, but is optionally 1-15 or, optionally, 1-8. “N\*”=0 to 15 or more, but is optionally 0, 1, 2, 3, 4, 5 or 6. In one embodiment, the top strand is the sense strand, and the bottom strand is the antisense strand. Alternatively, the bottom strand

is the sense strand and the top strand is the antisense strand, with 2'-O-methyl RNA monomers located at alternating residues along the top strand, rather than the bottom strand presently depicted in the above schematic.

**[0160]** In another such embodiment, the DsiRNA comprises:

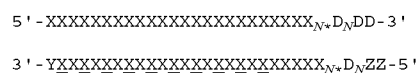

wherein “X”=RNA, “X”=2'-O-methyl RNA, “Y” is an optional overhang domain comprised of 0-10 RNA monomers that are optionally 2'-O-methyl RNA monomers—in certain embodiments, “Y” is an overhang domain comprised of 1-4 RNA monomers that are optionally 2'-O-methyl RNA monomers, “D”=DNA, “Z”=DNA or RNA, and “N”=1 to 50 or more, but is optionally 1-15 or, optionally, 1-8. “N\*”=0 to 15 or more, but is optionally 0, 1, 2, 3, 4, 5 or 6. In one embodiment, the top strand is the sense strand, and the bottom strand is the antisense strand. Alternatively, the bottom strand is the sense strand and the top strand is the antisense strand, with 2'-O-methyl RNA monomers located at alternating residues along the top strand, rather than the bottom strand presently depicted in the above schematic.

**[0161]** In another embodiment, the DsiRNA comprises:

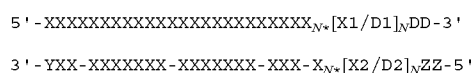

wherein “X”=RNA, “Y” is an optional overhang domain comprised of 0-10 RNA monomers that are optionally 2'-O-methyl RNA monomers—in certain embodiments, “Y” is an overhang domain comprised of 1-4 RNA monomers that are optionally 2'-O-methyl RNA monomers, “D”=DNA, “Z”=DNA or RNA, and “N”=1 to 50 or more, but is optionally 1-15 or, optionally, 1-8, where at least one D1<sub>N</sub> is present in the top strand and is base paired with a corresponding D2<sub>N</sub> in the bottom strand. Optionally, D1<sub>N</sub> and D1<sub>N+1</sub> are base paired with corresponding D2<sub>N</sub> and D2<sub>N+1</sub>; D1<sub>N</sub>, D1<sub>N+1</sub> and D1<sub>N+2</sub> are base paired with corresponding D2<sub>N</sub>, D1<sub>N+1</sub> and D1<sub>N+2</sub>, etc. “N\*”=0 to 15 or more, but is optionally 0, 1, 2, 3, 4, 5 or 6. In one embodiment, the top strand is the sense strand, and the bottom strand is the antisense strand. Alternatively, the bottom strand is the sense strand and the top strand is the antisense strand, with 2'-O-methyl RNA monomers located at alternating residues along the top strand, rather than the bottom strand presently depicted in the above schematic.

**[0162]** In any of the above-depicted structures, the 5' end of either the sense strand or antisense strand optionally comprises a phosphate group.

**[0163]** In another embodiment, the DNA:DNA-extended DsiRNA comprises strands having equal lengths possessing 1-3 mismatched residues that serve to orient Dicer cleavage (specifically, one or more of positions 1, 2 or 3 on the first strand of the DsiRNA, when numbering from the 3'-terminal residue, are mismatched with corresponding residues of the 5'-terminal region on the second strand when first and second

strands are annealed to one another). An exemplary DNA: DNA-extended DsiRNA agent with two terminal mismatched residues is shown:

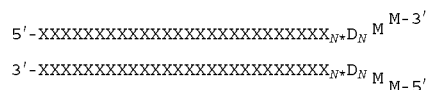

wherein “X”=RNA, “M”=Nucleic acid residues (RNA, DNA or non-natural or modified nucleic acids) that do not base pair (hydrogen bond) with corresponding “M” residues of otherwise complementary strand when strands are annealed, “D”=DNA and “N”=1 to 50 or more, but is optionally 1-15 or, optionally, 1-8. “N\*”=0 to 15 or more, but is optionally 0, 1, 2, 3, 4, 5 or 6. Any of the residues of such agents can optionally be 2'-O-methyl RNA monomers—alternating positioning of 2'-O-methyl RNA monomers that commences from the 3'-terminal residue of the bottom (second) strand, as shown for above asymmetric agents, can also be used in the above “blunt/fray” DsiRNA agent. In one embodiment, the top strand (first strand) is the sense strand, and the bottom strand (second strand) is the antisense strand. Alternatively, the bottom strand is the sense strand and the top strand is the antisense strand. Modification and DNA:DNA extension patterns paralleling those shown above for asymmetric/overhang agents can also be incorporated into such “blunt/frayed” agents.

[0164] In one embodiment, a length-extended DsiRNA agent is provided that comprises deoxyribonucleotides positioned at sites modeled to function via specific direction of Dicer cleavage, yet which does not require the presence of a base-paired deoxyribonucleotide in the dsNA structure. An exemplary structure for such a molecule is shown:

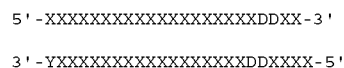

wherein “X”=RNA, “Y” is an optional overhang domain comprised of 0-10 RNA monomers that are optionally 2'-O-methyl RNA monomers—in certain embodiments, “Y” is an overhang domain comprised of 1-4 RNA monomers that are optionally 2'-O-methyl RNA monomers, and “D”=DNA. In one embodiment, the top strand is the sense strand, and the bottom strand is the antisense strand. Alternatively, the bottom strand is the sense strand and the top strand is the antisense strand. The above structure is modeled to force Dicer to cleave a minimum of a 21mer duplex as its primary post-processing form. In embodiments where the bottom strand of the above structure is the antisense strand, the positioning of two deoxyribonucleotide residues at the ultimate and penultimate residues of the 5' end of the antisense strand is likely to reduce off-target effects (as prior studies have shown a 2'-O-methyl modification of at least the penultimate position from the 5' terminus of the antisense strand to reduce off-target effects; see, e.g., US 2007/0223427).

[0165] In one embodiment, the DsiRNA comprises:

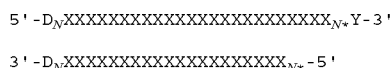

wherein “X”=RNA, “Y” is an optional overhang domain comprised of 0-10 RNA monomers that are optionally 2'-O-

methyl RNA monomers—in certain embodiments, “Y” is an overhang domain comprised of 1-4 RNA monomers that are optionally 2'-O-methyl RNA monomers, “D”=DNA, and “N”=1 to 50 or more, but is optionally 1-15 or, optionally, 1-8. “N\*”=0 to 15 or more, but is optionally 0, 1, 2, 3, 4, 5 or 6. In one embodiment, the top strand is the sense strand, and the bottom strand is the antisense strand. Alternatively, the bottom strand is the sense strand and the top strand is the antisense strand.

[0166] In a related embodiment, the DsiRNA comprises:

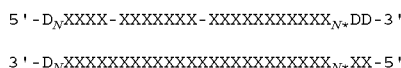

wherein “X”=RNA, optionally a 2'-O-methyl RNA monomers “D”=DNA, “N”=1 to 50 or more, but is optionally 1-15 or, optionally, 1-8. “N\*”=0 to 15 or more, but is optionally 0, 1, 2, 3, 4, 5 or 6. In one embodiment, the top strand is the sense strand, and the bottom strand is the antisense strand. Alternatively, the bottom strand is the sense strand and the top strand is the antisense strand.

[0167] In another such embodiment, the DsiRNA comprises:

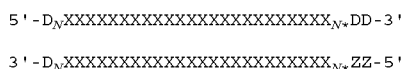

wherein “X”=RNA, optionally a 2'-O-methyl RNA monomers “D”=DNA, “N”=1 to 50 or more, but is optionally 1-15 or, optionally, 1-8. “N\*”=0 to 15 or more, but is optionally 0, 1, 2, 3, 4, 5 or 6. “Z”=DNA or RNA. In one embodiment, the top strand is the sense strand, and the bottom strand is the antisense strand. Alternatively, the bottom strand is the sense strand and the top strand is the antisense strand, with 2'-O-methyl RNA monomers located at alternating residues along the top strand, rather than the bottom strand presently depicted in the above schematic.

[0168] In another such embodiment, the DsiRNA comprises:

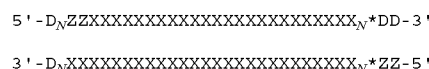

wherein “X”=RNA, “X”=2'-O-methyl RNA, “D”=DNA, “Z”=DNA or RNA, and “N”=1 to 50 or more, but is optionally 1-15 or, optionally, 1-8. “N\*”=0 to 15 or more, but is optionally 0, 1, 2, 3, 4, 5 or 6. In one embodiment, the top strand is the sense strand, and the bottom strand is the antisense strand. Alternatively, the bottom strand is the sense strand and the top strand is the antisense strand, with 2'-O-methyl RNA monomers located at alternating residues along the top strand, rather than the bottom strand presently depicted in the above schematic.

[0169] In another such embodiment, the DsiRNA comprises:

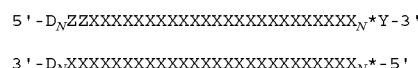

wherein “X”=RNA, “X”=2'-O-methyl RNA, “D”=DNA, “Z”=DNA or RNA, and “N”=1 to 50 or more, but is optionally 1-15 or, optionally, 1-8. “N\*”=0 to 15 or more, but is

optionally 0, 1, 2, 3, 4, 5 or 6. “Y” is an optional overhang domain comprised of 0-10 RNA monomers that are optionally 2'-O-methyl RNA monomers—in certain embodiments, “Y” is an overhang domain comprised of 1-4 RNA monomers that are optionally 2'-O-methyl RNA monomers. In one embodiment, the top strand is the sense strand, and the bottom strand is the antisense strand. Alternatively, the bottom strand is the sense strand and the top strand is the antisense strand, with 2'-O-methyl RNA monomers located at alternating residues along the top strand, rather than the bottom strand presently depicted in the above schematic.

[0170] In another embodiment, the DsiRNA comprises:

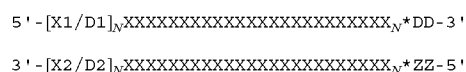

wherein “X”=RNA, “D”=DNA, “Z”=DNA or RNA, and “N”=1 to 50 or more, but is optionally 1-15 or, optionally, 1-8, where at least one D1<sub>N</sub> is present in the top strand and is base paired with a corresponding D2<sub>N</sub> in the bottom strand. Optionally, D1<sub>N</sub> and D1<sub>N+1</sub> are base paired with corresponding D2<sub>N</sub> and D2<sub>N+1</sub>; D1<sub>N</sub>, D1<sub>N+1</sub> and D1<sub>N+2</sub> are base paired with corresponding D2<sub>N</sub>, D1<sub>N+1</sub> and D1<sub>N+2</sub>, etc. “N\*”=0 to 15 or more, but is optionally 0, 1, 2, 3, 4, 5 or 6. In one embodiment, the top strand is the sense strand, and the bottom strand is the antisense strand. Alternatively, the bottom strand is the sense strand and the top strand is the antisense strand, with 2'-O-methyl RNA monomers located at alternating residues along the top strand, rather than the bottom strand presently depicted in the above schematic.

[0171] In a related embodiment, the DsiRNA comprises:

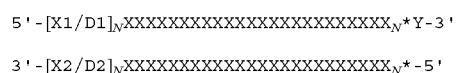

wherein “X”=RNA, “D”=DNA, “Y” is an optional overhang domain comprised of 0-10 RNA monomers that are optionally 2'-O-methyl RNA monomers—in certain embodiments, “Y” is an overhang domain comprised of 1-4 RNA monomers that are optionally 2'-O-methyl RNA monomers, and “N”=1 to 50 or more, but is optionally 1-15 or, optionally, 1-8, where at least one D1<sub>N</sub> is present in the top strand and is base paired with a corresponding D2<sub>N</sub> in the bottom strand. Optionally, D1<sub>N</sub> and D1<sub>N+1</sub> are base paired with corresponding D2<sub>N</sub> and D2<sub>N+1</sub>; D1<sub>N</sub>, D1<sub>N+1</sub> and D1<sub>N+2</sub> are base paired with corresponding D2<sub>N</sub>, D1<sub>N+1</sub> and D1<sub>N+2</sub>, etc. “N\*”=0 to 15 or more, but is optionally 0, 1, 2, 3, 4, 5 or 6. In one embodiment, the top strand is the sense strand, and the bottom strand is the antisense strand. Alternatively, the bottom strand is the sense strand and the top strand is the antisense strand, with 2'-O-methyl RNA monomers located at alternating residues along the top strand, rather than the bottom strand presently depicted in the above schematic.

[0172] In any of the above-depicted structures, the 5' end of either the sense strand or antisense strand optionally comprises a phosphate group.

[0173] In another embodiment, the DNA:DNA-extended DsiRNA comprises strands having equal lengths possessing 1-3 mismatched residues that serve to orient Dicer cleavage (specifically, one or more of positions 1, 2 or 3 on the first strand of the DsiRNA, when numbering from the 3'-terminal residue, are mismatched with corresponding residues of the

5'-terminal region on the second strand when first and second strands are annealed to one another). An exemplary DNA:DNA-extended DsiRNA agent with two terminal mismatched residues is shown:

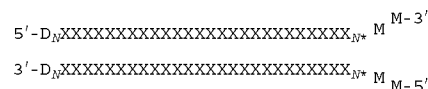

wherein “X”=RNA, “M”=Nucleic acid residues (RNA, DNA or non-natural or modified nucleic acids) that do not base pair (hydrogen bond) with corresponding “M” residues of otherwise complementary strand when strands are annealed, “D”=DNA and “N”=1 to 50 or more, but is optionally 1-15 or, optionally, 1-8. “N\*”=0 to 15 or more, but is optionally 0, 1, 2, 3, 4, 5 or 6. Any of the residues of such agents can optionally be 2'-O-methyl RNA monomers—alternating positioning of 2'-O-methyl RNA monomers that commences from the 3'-terminal residue of the bottom (second) strand, as shown for above asymmetric agents, can also be used in the above “blunt/fray” DsiRNA agent. In one embodiment, the top strand (first strand) is the sense strand, and the bottom strand (second strand) is the antisense strand. Alternatively, the bottom strand is the sense strand and the top strand is the antisense strand. Modification and DNA:DNA extension patterns paralleling those shown above for asymmetric/overhang agents can also be incorporated into such “blunt/frayed” agents.

[0174] In another embodiment, a length-extended DsiRNA agent is provided that comprises deoxyribonucleotides positioned at sites modeled to function via specific direction of Dicer cleavage, yet which does not require the presence of a base-paired deoxyribonucleotide in the dsNA structure. Exemplary structures for such a molecule are shown:

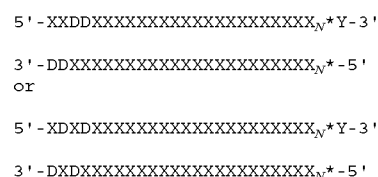

wherein “X”=RNA, “Y” is an optional overhang domain comprised of 0-10 RNA monomers that are optionally 2'-O-methyl RNA monomers—in certain embodiments, “Y” is an overhang domain comprised of 1-4 RNA monomers that are optionally 2'-O-methyl RNA monomers, and “D”=DNA. “N\*”=0 to 15 or more, but is optionally 0, 1, 2, 3, 4, 5 or 6. In one embodiment, the top strand is the sense strand, and the bottom strand is the antisense strand. Alternatively, the bottom strand is the sense strand and the top strand is the antisense strand. The above structures are modeled to force Dicer to cleave a minimum of a 21mer duplex as its primary post-processing form.

[0175] In any of the above embodiments where the bottom strand of the above structure is the antisense strand, the positioning of two deoxyribonucleotide residues at the ultimate and penultimate residues of the 5' end of the antisense strand is likely to reduce off-target effects (as prior studies have shown a 2'-O-methyl modification of at least the penultimate



position from the 5' terminus of the antisense strand to reduce off-target effects; see, e.g., US 2007/0223427).

**[0176]** The extended DsiRNAs of the invention can carry a broad range of modification patterns (e.g., 2'-O-methyl RNA patterns within extended DsiRNA agents). Certain preferred modification patterns of the second strand of the extended DsiRNAs of the invention are presented below—it is noted that while many of the below structures depict modification of non-extended DsiRNAs, the skilled artisan will recognize that the modification patterns shown are also readily applied to the full range of extended DsiRNA structures described elsewhere herein.

**[0177]** In one embodiment, the DsiRNA comprises:

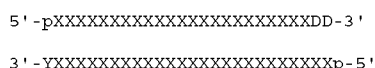

wherein “X”=RNA, “p”=a phosphate group, “Y” is an overhang domain comprised of 1-4 RNA monomers that are optionally 2'-O-methyl RNA monomers, and “D”=DNA. In one embodiment, the top strand is the sense strand, and the bottom strand is the antisense strand. Alternatively, the bottom strand is the sense strand and the top strand is the antisense strand.

**[0178]** In another embodiment, the DsiRNA comprises:

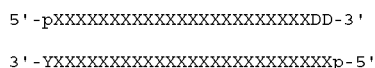

wherein “X”=RNA, “p”=a phosphate group, “X”=2'-O-methyl RNA, “Y” is an overhang domain comprised of 1-4 RNA monomers that are optionally 2'-O-methyl RNA monomers, underlined residues are 2'-O-methyl RNA monomers, and “D”=DNA. The top strand is the sense strand, and the bottom strand is the antisense strand.

**[0179]** In another embodiment, the DsiRNA comprises:

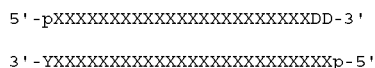

wherein “X”=RNA, “p”=a phosphate group, “X”=2'-O-methyl RNA, “Y” is an overhang domain comprised of 1-4 RNA monomers that are optionally 2'-O-methyl RNA monomers, underlined residues are 2'-O-methyl RNA monomers, and “D”=DNA. The top strand is the sense strand, and the bottom strand is the antisense strand.

**[0180]** In further embodiments, the DsiRNA comprises:

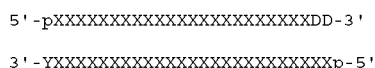

wherein “X”=RNA, “p”=a phosphate group, “X”=2'-O-methyl RNA, “Y” is an overhang domain comprised of 1-4 RNA monomers that are optionally 2'-O-methyl RNA monomers, underlined residues are 2'-O-methyl RNA monomers, and “D”=DNA. The top strand is the sense strand,

and the bottom strand is the antisense strand. In one embodiment, the DsiRNA comprises:

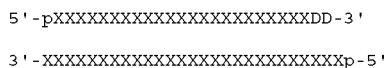

wherein “X”=RNA, “p”=a phosphate group, “X”=2'-O-methyl RNA, and “D”=DNA. The top strand is the sense strand, and the bottom strand is the antisense strand.

**[0181]** In additional embodiments, the DsiRNA comprises:

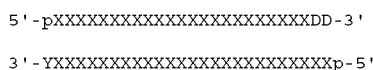

wherein “X”=RNA, “p”=a phosphate group, “X”=2'-O-methyl RNA, “Y” is an overhang domain comprised of 1-4 RNA monomers that are optionally 2'-O-methyl RNA monomers, underlined residues are 2'-O-methyl RNA monomers, and “D”=DNA. The top strand is the sense strand, and the bottom strand is the antisense strand. In one embodiment, the DsiRNA comprises:

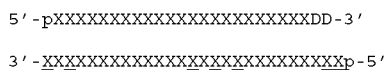

wherein “X”=RNA, “p”=a phosphate group, “X”=2'-O-methyl RNA, and “D”=DNA. The top strand is the sense strand, and the bottom strand is the antisense strand.

**[0182]** In other embodiments, the DsiRNA comprises:

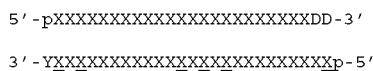

wherein “X”=RNA, “p”=a phosphate group, “X”=2'-O-methyl RNA, “Y” is an overhang domain comprised of 1-4 RNA monomers that are optionally 2'-O-methyl RNA monomers, underlined residues are 2'-O-methyl RNA monomers, and “D”=DNA. The top strand is the sense strand, and the bottom strand is the antisense strand. In one embodiment, the DsiRNA comprises:

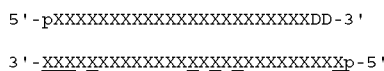

wherein “X”=RNA, “p”=a phosphate group, “X”=2'-O-methyl RNA, and “D”=DNA. The top strand is the sense strand, and the bottom strand is the antisense strand.

**[0183]** In further embodiments, the DsiRNA comprises:

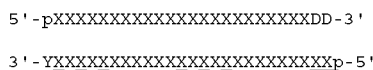

wherein “X”=RNA, “p”=a phosphate group, “X”=2'-O-methyl RNA, “Y” is an overhang domain comprised of 1-4 RNA monomers that are optionally 2'-O-methyl RNA monomers, underlined residues are 2'-O-methyl RNA monomers, and “D”=DNA. The top strand is the sense strand,

and the bottom strand is the antisense strand. In one embodiment, the DsiRNA comprises:

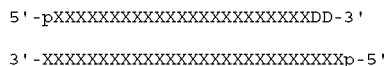

wherein “X”=RNA, “p”=a phosphate group, “X”=2'-O-methyl RNA, and “D”=DNA. The top strand is the sense strand, and the bottom strand is the antisense strand.

**[0184]** In additional embodiments, the DsiRNA comprises:

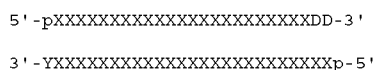

wherein “X”=RNA, “p”=a phosphate group, “X”=2'-O-methyl RNA, “Y” is an overhang domain comprised of 1-4 RNA monomers that are optionally 2'-O-methyl RNA monomers, underlined residues are 2'-O-methyl RNA monomers, and “D”=DNA. The top strand is the sense strand, and the bottom strand is the antisense strand. In one embodiment, the DsiRNA comprises:

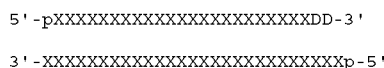

wherein “X”=RNA, “p”=a phosphate group, “X”=2'-O-methyl RNA, and “D”=DNA. The top strand is the sense strand, and the bottom strand is the antisense strand.

**[0185]** In other embodiments, the DsiRNA comprises:

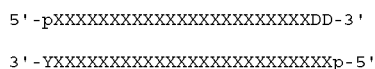

wherein “X”=RNA, “p”=a phosphate group, “X”=2'-O-methyl RNA, “Y” is an overhang domain comprised of 1-4 RNA monomers that are optionally 2'-O-methyl RNA monomers, underlined residues are 2'-O-methyl RNA monomers, and “D”=DNA. The top strand is the sense strand, and the bottom strand is the antisense strand. In one embodiment, the DsiRNA comprises:

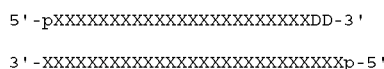

wherein “X”=RNA, “p”=a phosphate group, “X”=2'-O-methyl RNA, and “D”=DNA. The top strand is the sense strand, and the bottom strand is the antisense strand.

**[0186]** In certain additional embodiments, the DsiRNA comprises:

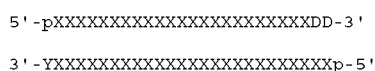

wherein “X”=RNA, “p”=a phosphate group, “X”=2'-O-methyl RNA, “Y” is an overhang domain com-

prised of 1-4 RNA monomers that are optionally 2'-O-methyl RNA monomers, underlined residues are 2'-O-methyl RNA monomers, and “D”=DNA. The top strand is the sense strand, and the bottom strand is the antisense strand. In one embodiment, the DsiRNA comprises:

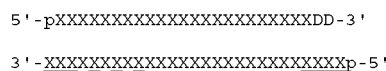

wherein “X”=RNA, “p”=a phosphate group, “X”=2'-O-methyl RNA, and “D”=DNA. The top strand is the sense strand, and the bottom strand is the antisense strand.

**[0187]** In additional embodiments, the DsiRNA comprises:

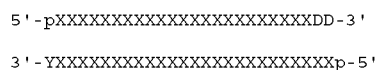

wherein “X”=RNA, “p”=a phosphate group, “X”=2'-O-methyl RNA, “Y” is an overhang domain comprised of 1-4 RNA monomers that are optionally 2'-O-methyl RNA monomers, underlined residues are 2'-O-methyl RNA monomers, and “D”=DNA. The top strand is the sense strand, and the bottom strand is the antisense strand. In one embodiment, the DsiRNA comprises:

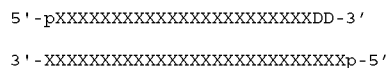

wherein “X”=RNA, “p”=a phosphate group, “X”=2'-O-methyl RNA, and “D”=DNA. The top strand is the sense strand, and the bottom strand is the antisense strand.

**[0188]** In further embodiments, the DsiRNA comprises:

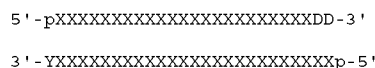

wherein “X”=RNA, “p”=a phosphate group, “X”=2'-O-methyl RNA, “Y” is an overhang domain comprised of 1-4 RNA monomers that are optionally 2'-O-methyl RNA monomers, underlined residues are 2'-O-methyl RNA monomers, and “D”=DNA. The top strand is the sense strand, and the bottom strand is the antisense strand. In one embodiment, the DsiRNA comprises:

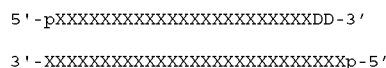

wherein “X”=RNA, “p”=a phosphate group, “X”=2'-O-methyl RNA, and “D”=DNA. The top strand is the sense strand, and the bottom strand is the antisense strand.

**[0189]** In another embodiment, the DsiRNA comprises strands having equal lengths possessing 1-3 mismatched residues that serve to orient Dicer cleavage (specifically, one or more of positions 1, 2 or 3 on the first strand of the DsiRNA, when numbering from the 3'-terminal residue, are mismatched with corresponding residues of the 5'-terminal

region on the second strand when first and second strands are annealed to one another). An exemplary 27mer DsiRNA agent with two terminal mismatched residues is shown:

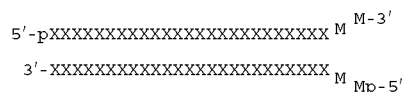

wherein “X”=RNA, “p”=a phosphate group, “M”=Nucleic acid residues (RNA, DNA or non-natural or modified nucleic acids) that do not base pair (hydrogen bond) with corresponding “M” residues of otherwise complementary strand when strands are annealed. Any of the residues of such agents can optionally be 2'-O-methyl RNA monomers—alternating positioning of 2'-O-methyl RNA monomers that commences from the 3'-terminal residue of the bottom (second) strand, as shown for above asymmetric agents, can also be used in the above “blunt/fray” DsiRNA agent. In one embodiment, the top strand is the sense strand, and the bottom strand is the antisense strand. Alternatively, the bottom strand is the sense strand and the top strand is the antisense strand.

**[0190]** As used herein “DsiRNAm” refers to a DisRNA having a “mismatch tolerant region” containing one, two, three or four mismatched base pairs of the duplex formed by the sense and antisense strands of the DsiRNA, where such mismatches are positioned within the DsiRNA at a location(s) lying between (and thus not including) the two terminal base pairs of either end of the DsiRNA. The mismatched base pairs are located within a “mismatch-tolerant region” which is defined herein with respect to the location of the projected Ago2 cut site of the corresponding target nucleic acid. The mismatch tolerant region is located “upstream of” the projected Ago2 cut site of the target strand. “Upstream” in this context will be understood as the 5'-most portion of the DsiRNAm duplex, where 5' refers to the orientation of the sense strand of the DsiRNA duplex. Therefore, the mismatch tolerant region is upstream of the base on the sense (passenger) strand that corresponds to the projected Ago2 cut site of the target nucleic acid (see FIG. 14); alternatively, when referring to the antisense (guide) strand of the DsiRNAm, the mismatch tolerant region can also be described as positioned downstream of the base that is complementary to the projected Ago2 cut site of the target nucleic acid, that is, the 3'-most portion of the antisense strand of the DsiRNAm (where position 1 of the antisense strand is the 5' terminal nucleotide of the antisense strand, see FIG. 20).

**[0191]** In one embodiment, for example as depicted in FIG. 33, the mismatch tolerant region is positioned between and including base pairs 3-9 when numbered from the nucleotide starting at the 5' end of the sense strand of the duplex. Therefore, a DsiRNAm of the invention possesses a single mismatched base pair at any one of positions 3, 4, 5, 6, 7, 8 or 9 of the sense strand of a right-hand extended DsiRNA (where position 1 is the 5' terminal nucleotide of the sense strand and position 9 is the nucleotide residue of the sense strand that is immediately 5' of the projected Ago2 cut site of the target RNA sequence corresponding to the sense strand sequence). In certain embodiments, for a DsiRNAm that possesses a mismatched base pair nucleotide at any of positions 3, 4, 5, 6, 7, 8 or 9 of the sense strand, the corresponding mismatched base pair nucleotide of the antisense strand not only forms a mismatched base pair with the DsiRNAm sense strand

sequence, but also forms a mismatched base pair with a DsiRNAm target RNA sequence (thus, complementarity between the antisense strand sequence and the sense strand sequence is disrupted at the mismatched base pair within the DsiRNAm, and complementarity is similarly disrupted between the antisense strand sequence of the DsiRNAm and the target RNA sequence). In alternative embodiments, the mismatch base pair nucleotide of the antisense strand of a DsiRNAm only form a mismatched base pair with a corresponding nucleotide of the sense strand sequence of the DsiRNAm, yet base pairs with its corresponding target RNA sequence nucleotide (thus, complementarity between the antisense strand sequence and the sense strand sequence is disrupted at the mismatched base pair within the DsiRNAm, yet complementarity is maintained between the antisense strand sequence of the DsiRNAm and the target RNA sequence).

**[0192]** A DsiRNAm of the invention that possesses a single mismatched base pair within the mismatch-tolerant region (mismatch region) as described above (e.g., a DsiRNAm harboring a mismatched nucleotide residue at any one of positions 3, 4, 5, 6, 7, 8 or 9 of the sense strand) can further include one, two or even three additional mismatched base pairs. In preferred embodiments, these one, two or three additional mismatched base pairs of the DsiRNAm occur at position(s) 3, 4, 5, 6, 7, 8 and/or 9 of the sense strand (and at corresponding residues of the antisense strand). In one embodiment where one additional mismatched base pair is present within a DsiRNAm, the two mismatched base pairs of the sense strand can occur, e.g., at nucleotides of both position 4 and position 6 of the sense strand (with mismatch also occurring at corresponding nucleotide residues of the antisense strand).

**[0193]** In DsiRNAm agents possessing two mismatched base pairs, mismatches can occur consecutively (e.g., at consecutive positions along the sense strand nucleotide sequence). Alternatively, nucleotides of the sense strand that form mismatched base pairs with the antisense strand sequence can be interspersed by nucleotides that base pair with the antisense strand sequence (e.g., for a DsiRNAm possessing mismatched nucleotides at positions 3 and 6, but not at positions 4 and 5, the mismatched residues of sense strand positions 3 and 6 are interspersed by two nucleotides that form matched base pairs with corresponding residues of the antisense strand). For example, two residues of the sense strand (located within the mismatch-tolerant region of the sense strand) that form mismatched base pairs with the corresponding antisense strand sequence can occur with zero, one, two, three, four or five matched base pairs located between these mismatched base pairs.

**[0194]** For certain DsiRNAm agents possessing three mismatched base pairs, mismatches can occur consecutively (e.g., in a triplet along the sense strand nucleotide sequence). Alternatively, nucleotides of the sense strand that form mismatched base pairs with the antisense strand sequence can be interspersed by nucleotides that form matched base pairs with the antisense strand sequence (e.g., for a DsiRNAm possessing mismatched nucleotides at positions 3, 4 and 8, but not at positions 5, 6 and 7, the mismatched residues of sense strand positions 3 and 4 are adjacent to one another, while the mismatched residues of sense strand positions 4 and 8 are interspersed by three nucleotides that form matched base pairs with corresponding residues of the antisense strand). For example, three residues of the sense strand (located

within the mismatch-tolerant region of the sense strand) that form mismatched base pairs with the corresponding antisense strand sequence can occur with zero, one, two, three or four matched base pairs located between any two of these mismatched base pairs.

**[0195]** For certain DsiRNAm agents possessing four mismatched base pairs, mismatches can occur consecutively (e.g., in a quadruplet along the sense strand nucleotide sequence). Alternatively, nucleotides of the sense strand that form mismatched base pairs with the antisense strand sequence can be interspersed by nucleotides that form matched base pairs with the antisense strand sequence (e.g., for a DsiRNAm possessing mismatched nucleotides at positions 3, 5, 7 and 8, but not at positions 4 and 6, the mismatched residues of sense strand positions 7 and 8 are adjacent to one another, while the mismatched residues of sense strand positions 3 and 5 are interspersed by one nucleotide that forms a matched base pair with the corresponding residue of the antisense strand—similarly, the mismatched residues of sense strand positions 5 and 7 are also interspersed by one nucleotide that forms a matched base pair with the corresponding residue of the antisense strand). For example, four residues of the sense strand (located within the mismatch-tolerant region of the sense strand) that form mismatched base pairs with the corresponding antisense strand sequence can occur with zero, one, two or three matched base pairs located between any two of these mismatched base pairs.

**[0196]** In another embodiment, for example as depicted in FIG. 39, a DsiRNAm of the invention comprises a mismatch tolerant region which possesses a single mismatched base pair nucleotide at any one of positions 13, 14, 15, 16, 17, 18, 19, 20 or 21 of the antisense strand of a left-hand extended DsiRNA (where position 1 is the 5' terminal nucleotide of the antisense strand and position 13 is the nucleotide residue of the antisense strand that is immediately 3' (downstream) in the antisense strand of the projected Ago2 cut site of the target RNA sequence sufficiently complementary to the antisense strand sequence). In certain embodiments, for a DsiRNAm that possesses a mismatched base pair nucleotide at any of positions 13, 14, 15, 16, 17, 18, 19, 20 or 21 of the antisense strand with respect to the sense strand of the DsiRNAm, the mismatched base pair nucleotide of the antisense strand not only forms a mismatched base pair with the DsiRNAm sense strand sequence, but also forms a mismatched base pair with a DsiRNAm target RNA sequence (thus, complementarity between the antisense strand sequence and the sense strand sequence is disrupted at the mismatched base pair within the DsiRNAm, and complementarity is similarly disrupted between the antisense strand sequence of the DsiRNAm and the target RNA sequence). In alternative embodiments, the mismatch base pair nucleotide of the antisense strand of a DsiRNAm only forms a mismatched base pair with a corresponding nucleotide of the sense strand sequence of the DsiRNAm, yet base pairs with its corresponding target RNA sequence nucleotide (thus, complementarity between the antisense strand sequence and the sense strand sequence is disrupted at the mismatched base pair within the DsiRNAm, yet complementarity is maintained between the antisense strand sequence of the DsiRNAm and the target RNA sequence).

**[0197]** A DsiRNAm of the invention that possesses a single mismatched base pair within the mismatch-tolerant region as described above (e.g., a DsiRNAm harboring a

mismatched nucleotide residue at positions 13, 14, 15, 16, 17, 18, 19, 20 or 21 of the antisense strand) can further include one, two or even three additional mismatched base pairs. In preferred embodiments, these one, two or three additional mismatched base pairs of the DsiRNAm occur at position (s) 13, 14, 15, 16, 17, 18, 19, 20 and/or 21 of the antisense strand (and at corresponding residues of the sense strand). In one embodiment where one additional mismatched base pair is present within a DsiRNAm, the two mismatched base pairs of the antisense strand can occur, e.g., at nucleotides of both position 14 and position 18 of the antisense strand (with mismatch also occurring at corresponding nucleotide residues of the sense strand).

**[0198]** In DsiRNAm agents possessing two mismatched base pairs, mismatches can occur consecutively (e.g., at consecutive positions along the antisense strand nucleotide sequence). Alternatively, nucleotides of the antisense strand that form mismatched base pairs with the sense strand sequence can be interspersed by nucleotides that base pair with the sense strand sequence (e.g., for a DsiRNAm possessing mismatched nucleotides at positions 13 and 16, but not at positions 14 and 15, the mismatched residues of antisense strand positions 13 and 16 are interspersed by two nucleotides that form matched base pairs with corresponding residues of the sense strand). For example, two residues of the antisense strand (located within the mismatch-tolerant region of the sense strand) that form mismatched base pairs with the corresponding sense strand sequence can occur with zero, one, two, three, four, five, six or seven matched base pairs located between these mismatched base pairs.

**[0199]** For certain DsiRNAm agents possessing three mismatched base pairs, mismatches can occur consecutively (e.g., in a triplet along the antisense strand nucleotide sequence). Alternatively, nucleotides of the antisense strand that form mismatched base pairs with the sense strand sequence can be interspersed by nucleotides that form matched base pairs with the sense strand sequence (e.g., for a DsiRNAm possessing mismatched nucleotides at positions 13, 14 and 18, but not at positions 15, 16 and 17, the mismatched residues of antisense strand positions 13 and 14 are adjacent to one another, while the mismatched residues of antisense strand positions 14 and 18 are interspersed by three nucleotides that form matched base pairs with corresponding residues of the sense strand). For example, three residues of the antisense strand (located within the mismatch-tolerant region of the antisense strand) that form mismatched base pairs with the corresponding sense strand sequence can occur with zero, one, two, three, four, five or six matched base pairs located between any two of these mismatched base pairs.

**[0200]** For certain DsiRNAm agents possessing four mismatched base pairs, mismatches can occur consecutively (e.g., in a quadruplet along the antisense strand nucleotide sequence). Alternatively, nucleotides of the antisense strand that form mismatched base pairs with the sense strand sequence can be interspersed by nucleotides that form matched base pairs with the sense strand sequence (e.g., for a DsiRNAm possessing mismatched nucleotides at positions 13, 15, 17 and 18, but not at positions 14 and 16, the mismatched residues of antisense strand positions 17 and 18 are adjacent to one another, while the mismatched residues of antisense strand positions 13 and 15 are interspersed by one nucleotide that forms a matched base pair with the corresponding residue of the sense strand—similarly, the mismatched residues of antisense strand positions 15 and 17 are

also interspersed by one nucleotide that forms a matched base pair with the corresponding residue of the sense strand). For example, four residues of the antisense strand (located within the mismatch-tolerant region of the antisense strand) that form mismatched base pairs with the corresponding sense strand sequence can occur with zero, one, two, three, four or five matched base pairs located between any two of these mismatched base pairs.

**[0201]** In a further embodiment, for example as depicted in FIG. 40, a DsiRNAm of the invention possesses a single mismatched base pair nucleotide at any one of positions 11, 12, 13, 14, 15, 16, 17, 18 or 19 of the antisense strand of a left-hand extended DsiRNA (where position 1 is the 5' terminal nucleotide of the antisense strand and position 11 is the nucleotide residue of the antisense strand that is immediately 3' (downstream) in the antisense strand of the projected Ago2 cut site of the target RNA sequence sufficiently complementary to the antisense strand sequence). In certain embodiments, for a DsiRNAm that possesses a mismatched base pair nucleotide at any of positions 11, 12, 13, 14, 15, 16, 17, 18 or 19 of the antisense strand with respect to the sense strand of the DsiRNAm, the mismatched base pair nucleotide of the antisense strand not only forms a mismatched base pair with the DsiRNAm sense strand sequence, but also forms a mismatched base pair with a DsiRNAm target RNA sequence (thus, complementarity between the antisense strand sequence and the sense strand sequence is disrupted at the mismatched base pair within the DsiRNAm, and complementarity is similarly disrupted between the antisense strand sequence of the DsiRNAm and the target RNA sequence). In alternative embodiments, the mismatch base pair nucleotide of the antisense strand of a DsiRNAm only forms a mismatched base pair with a corresponding nucleotide of the sense strand sequence of the DsiRNAm, yet this same antisense strand nucleotide base pairs with its corresponding target RNA sequence nucleotide (thus, complementarity between the antisense strand sequence and the sense strand sequence is disrupted at the mismatched base pair within the DsiRNAm, yet complementarity is maintained between the antisense strand sequence of the DsiRNAm and the target RNA sequence).

**[0202]** A DsiRNAm of the invention that possesses a single mismatched base pair within the mismatch-tolerant region as described above (e.g., a DsiRNAm harboring a mismatched nucleotide residue at positions 11, 12, 13, 14, 15, 16, 17, 18 or 19 of the antisense strand) can further include one, two or even three additional mismatched base pairs. In preferred embodiments, these one, two or three additional mismatched base pairs of the DsiRNAm occur at position (s) 11, 12, 13, 14, 15, 16, 17, 18 and/or 19 of the antisense strand (and at corresponding residues of the sense strand). In one embodiment where one additional mismatched base pair is present within a DsiRNAm, the two mismatched base pairs of the antisense strand can occur, e.g., at nucleotides of both position 14 and position 18 of the antisense strand (with mismatch also occurring at corresponding nucleotide residues of the sense strand).

**[0203]** In DsiRNAm agents possessing two mismatched base pairs, mismatches can occur consecutively (e.g., at consecutive positions along the antisense strand nucleotide sequence). Alternatively, nucleotides of the antisense strand that form mismatched base pairs with the sense strand sequence can be interspersed by nucleotides that base pair with the sense strand sequence (e.g., for a DsiRNAm pos-

sessing mismatched nucleotides at positions 12 and 15, but not at positions 13 and 14, the mismatched residues of antisense strand positions 12 and 15 are interspersed by two nucleotides that form matched base pairs with corresponding residues of the sense strand). For example, two residues of the antisense strand (located within the mismatch-tolerant region of the sense strand) that form mismatched base pairs with the corresponding sense strand sequence can occur with zero, one, two, three, four, five, six or seven matched base pairs located between these mismatched base pairs.

**[0204]** For certain DsiRNAm agents possessing three mismatched base pairs, mismatches can occur consecutively (e.g., in a triplet along the antisense strand nucleotide sequence). Alternatively, nucleotides of the antisense strand that form mismatched base pairs with the sense strand sequence can be interspersed by nucleotides that form matched base pairs with the sense strand sequence (e.g., for a DsiRNAm possessing mismatched nucleotides at positions 13, 14 and 18, but not at positions 15, 16 and 17, the mismatched residues of antisense strand positions 13 and 14 are adjacent to one another, while the mismatched residues of antisense strand positions 14 and 18 are interspersed by three nucleotides that form matched base pairs with corresponding residues of the sense strand). For example, three residues of the antisense strand (located within the mismatch-tolerant region of the antisense strand) that form mismatched base pairs with the corresponding sense strand sequence can occur with zero, one, two, three, four, five or six matched base pairs located between any two of these mismatched base pairs.

**[0205]** For certain DsiRNAm agents possessing four mismatched base pairs, mismatches can occur consecutively (e.g., in a quadruplet along the antisense strand nucleotide sequence). Alternatively, nucleotides of the antisense strand that form mismatched base pairs with the sense strand sequence can be interspersed by nucleotides that form matched base pairs with the sense strand sequence (e.g., for a DsiRNAm possessing mismatched nucleotides at positions 13, 15, 17 and 18, but not at positions 14 and 16, the mismatched residues of antisense strand positions 17 and 18 are adjacent to one another, while the mismatched residues of antisense strand positions 13 and 15 are interspersed by one nucleotide that forms a matched base pair with the corresponding residue of the sense strand—similarly, the mismatched residues of antisense strand positions 15 and 17 are also interspersed by one nucleotide that forms a matched base pair with the corresponding residue of the sense strand). For example, four residues of the antisense strand (located within the mismatch-tolerant region of the antisense strand) that form mismatched base pairs with the corresponding sense strand sequence can occur with zero, one, two, three, four or five matched base pairs located between any two of these mismatched base pairs.

**[0206]** In an additional embodiment, for example as depicted in FIG. 41, a DsiRNAm of the invention possesses a single mismatched base pair nucleotide at any one of positions 15, 16, 17, 18, 19, 20, 21, 22 or 23 of the antisense strand of a left-hand extended DsiRNA (where position 1 is the 5' terminal nucleotide of the antisense strand and position 15 is the nucleotide residue of the antisense strand that is immediately 3' (downstream) in the antisense strand of the projected Ago2 cut site of the target RNA sequence sufficiently complementary to the antisense strand sequence). In certain embodiments, for a DsiRNAm that possesses a mismatched base pair nucleotide at any of positions 15, 16, 17, 18, 19, 20, 21,

22 or 23 of the antisense strand with respect to the sense strand of the DsiRNAm, the mismatched base pair nucleotide of the antisense strand not only forms a mismatched base pair with the DsiRNAm sense strand sequence, but also forms a mismatched base pair with a DsiRNAm target RNA sequence (thus, complementarity between the antisense strand sequence and the sense strand sequence is disrupted at the mismatched base pair within the DsiRNAm, and complementarity is similarly disrupted between the antisense strand sequence of the DsiRNAm and the target RNA sequence). In alternative embodiments, the mismatch base pair nucleotide of the antisense strand of a DsiRNAm only forms a mismatched base pair with a corresponding nucleotide of the sense strand sequence of the DsiRNAm, yet this same antisense strand nucleotide base pairs with its corresponding target RNA sequence nucleotide (thus, complementarity between the antisense strand sequence and the sense strand sequence is disrupted at the mismatched base pair within the DsiRNAm, yet complementarity is maintained between the antisense strand sequence of the DsiRNAm and the target RNA sequence).

**[0207]** A DsiRNAm of the invention that possesses a single mismatched base pair within the mismatch-tolerant region as described above (e.g., a DsiRNAm harboring a mismatched nucleotide residue at positions 15, 16, 17, 18, 19, 20, 21, 22 or 23 of the antisense strand) can further include one, two or even three additional mismatched base pairs. In preferred embodiments, these one, two or three additional mismatched base pairs of the DsiRNAm occur at position (s) 15, 16, 17, 18, 19, 20, 21, 22 and/or 23 of the antisense strand (and at corresponding residues of the sense strand). In one embodiment where one additional mismatched base pair is present within a DsiRNAm, the two mismatched base pairs of the antisense strand can occur, e.g., at nucleotides of both position 16 and position 20 of the antisense strand (with mismatch also occurring at corresponding nucleotide residues of the sense strand).

**[0208]** In DsiRNAm agents possessing two mismatched base pairs, mismatches can occur consecutively (e.g., at consecutive positions along the antisense strand nucleotide sequence). Alternatively, nucleotides of the antisense strand that form mismatched base pairs with the sense strand sequence can be interspersed by nucleotides that base pair with the sense strand sequence (e.g., for a DsiRNAm possessing mismatched nucleotides at positions 16 and 20, but not at positions 17, 18 and 19, the mismatched residues of antisense strand positions 16 and 20 are interspersed by three nucleotides that form matched base pairs with corresponding residues of the sense strand). For example, two residues of the antisense strand (located within the mismatch-tolerant region of the sense strand) that form mismatched base pairs with the corresponding sense strand sequence can occur with zero, one, two, three, four, five, six or seven matched base pairs located between these mismatched base pairs.

**[0209]** For certain DsiRNAm agents possessing three mismatched base pairs, mismatches can occur consecutively (e.g., in a triplet along the antisense strand nucleotide sequence). Alternatively, nucleotides of the antisense strand that form mismatched base pairs with the sense strand sequence can be interspersed by nucleotides that form matched base pairs with the sense strand sequence (e.g., for a DsiRNAm possessing mismatched nucleotides at positions 16, 17 and 21, but not at positions 18, 19 and 20, the mismatched residues of antisense strand positions 16 and 17 are

adjacent to one another, while the mismatched residues of antisense strand positions 17 and 21 are interspersed by three nucleotides that form matched base pairs with corresponding residues of the sense strand). For example, three residues of the antisense strand (located within the mismatch-tolerant region of the antisense strand) that form mismatched base pairs with the corresponding sense strand sequence can occur with zero, one, two, three, four, five or six matched base pairs located between any two of these mismatched base pairs.

**[0210]** For certain DsiRNAm agents possessing four mismatched base pairs, mismatches can occur consecutively (e.g., in a quadruplet along the antisense strand nucleotide sequence). Alternatively, nucleotides of the antisense strand that form mismatched base pairs with the sense strand sequence can be interspersed by nucleotides that form matched base pairs with the sense strand sequence (e.g., for a DsiRNAm possessing mismatched nucleotides at positions 17, 19, 21 and 22, but not at positions 18 and 20, the mismatched residues of antisense strand positions 21 and 22 are adjacent to one another, while the mismatched residues of antisense strand positions 17 and 19 are interspersed by one nucleotide that forms a matched base pair with the corresponding residue of the sense strand—similarly, the mismatched residues of antisense strand positions 19 and 21 are also interspersed by one nucleotide that forms a matched base pair with the corresponding residue of the sense strand). For example, four residues of the antisense strand (located within the mismatch-tolerant region of the antisense strand) that form mismatched base pairs with the corresponding sense strand sequence can occur with zero, one, two, three, four or five matched base pairs located between any two of these mismatched base pairs.

**[0211]** For reasons of clarity, the location(s) of mismatched nucleotide residues within the above DsiRNAm agents are numbered in reference to the 5' terminal residue of either sense or antisense strands of the DsiRNAm. As noted for the different left-extended DsiRNAm agents exemplified in FIGS. 20, 21 and 22, the numbering of positions located within the mismatch-tolerant region (mismatch region) of the antisense strand can shift with variations in the proximity of the 5' terminus of the antisense strand to the projected Ago2 cleavage site. Thus, the location(s) of preferred mismatch sites within either antisense strand or sense strand can also be identified as the permissible proximity of such mismatches to the projected Ago2 cut site. Accordingly, in one preferred embodiment, the position of a mismatch nucleotide of the sense strand of a DsiRNAm is the nucleotide residue of the sense strand that is located immediately 5' (upstream) of the projected Ago2 cleavage site of the corresponding target RNA sequence. In other preferred embodiments, a mismatch nucleotide of the sense strand of a DsiRNAm is positioned at the nucleotide residue of the sense strand that is located two nucleotides 5' (upstream) of the projected Ago2 cleavage site, three nucleotides 5' (upstream) of the projected Ago2 cleavage site, four nucleotides 5' (upstream) of the projected Ago2 cleavage site, five nucleotides 5' (upstream) of the projected Ago2 cleavage site, six nucleotides 5' (upstream) of the projected Ago2 cleavage site, seven nucleotides 5' (upstream) of the projected Ago2 cleavage site, eight nucleotides 5' (upstream) of the projected Ago2 cleavage site, or nine nucleotides 5' (upstream) of the projected Ago2 cleavage site.

**[0212]** Exemplary single mismatch-containing 25/27mer DsiRNAs (DsiRNAm) include the following structures

(such mismatch-containing structures may also be incorporated into other exemplary DsiRNA structures shown herein).

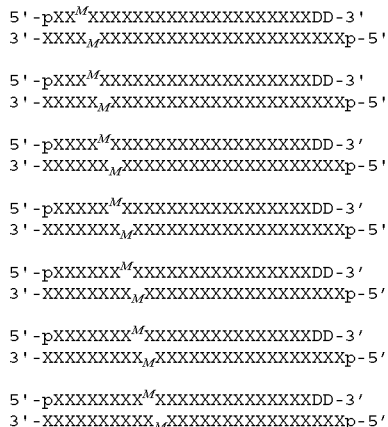

wherein “X”=RNA, “D”=DNA, “p”=a phosphate group. “M”=Nucleic acid residues (RNA, DNA or non-natural or modified nucleic acids) that do not base pair (hydrogen bond) with corresponding “M” residues of otherwise complementary strand when strands are annealed. Any of the residues of such agents can optionally be 2'-O-methyl RNA monomers—alternating positioning of 2'-O-methyl RNA monomers that commences from the 3'-terminal residue of the bottom (second) strand, as shown above, can also be used in the above DsiRNAm agents. For the above mismatch structures, the top strand is the sense strand, and the bottom strand is the antisense strand.

[0213] In certain embodiments, a DsiRNA of the invention can contain mismatches that exist in reference to the target RNA sequence yet do not necessarily exist as mismatched base pairs within the two strands of the DsiRNA—thus, a DsiRNA can possess perfect complementarity between first and second strands of a DsiRNA, yet still possess mismatched residues in reference to a target RNA (which, in certain embodiments, may be advantageous in promoting efficacy and/or potency and/or duration of effect). In certain embodiments, where mismatches occur between antisense strand and target RNA sequence, the position of a mismatch is located within the antisense strand at a position(s) that corresponds to a sequence of the sense strand located 5' of the projected Ago2 cut site of the target region—e.g., antisense strand residue(s) positioned within the antisense strand to the 3' of the antisense residue which is complementary to the projected Ago2 cut site of the target sequence (such region is indicated within, e.g., FIG. 33 as a “mismatch region”, which is distinct from the projected “seed region” of such DsiRNAs).

[0214] Exemplary 25/27mer DsiRNAs that harbor a single mismatched residue in reference to target sequences include the following preferred structures.

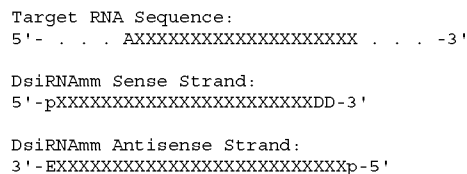

-continued

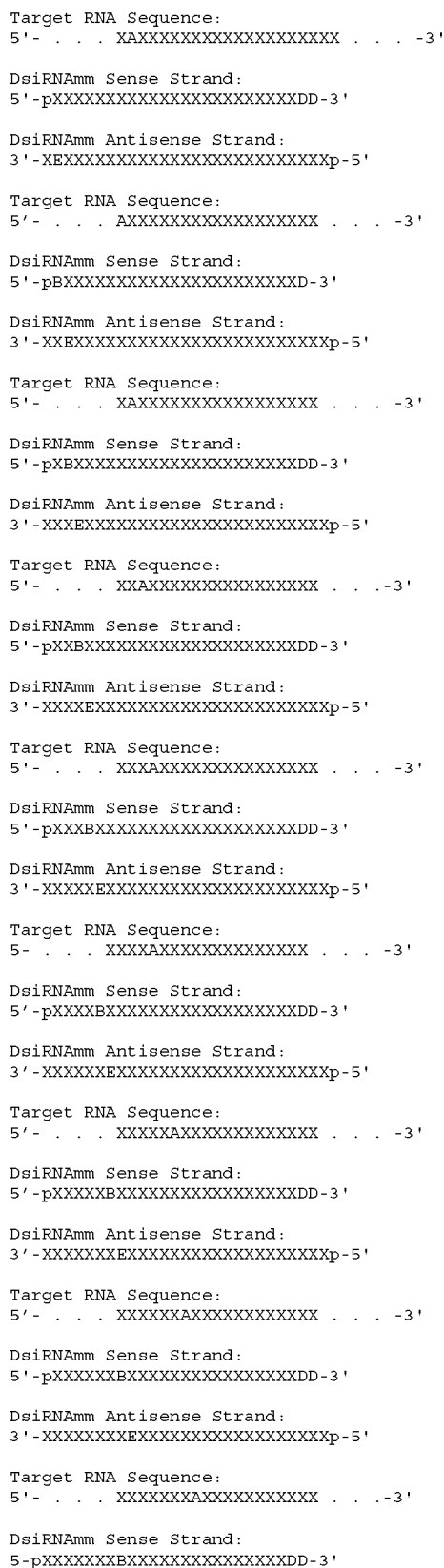

-continued

```

DsiRNAm Antisense Strand:
3'-XXXXXXXXXXEXXXXXXXXXXXXXXXXXp-5'

Target RNA Sequence:
5'- . . . XXXXXXXXXXXXXXXXXXXX . . . -3'

DsiRNAm Sense Strand:
5'-pXXXXXXXXXXBXXXXXXXXXXXXXXXXDD-3'

DsiRNAm Antisense Strand:
3'-XXXXXXXXXXEXXXXXXXXXXXXXXXXXp-5'

```

wherein “X”=RNA, “D”=DNA, “p”=a phosphate group, “E”=Nucleic acid residues (RNA, DNA or non-natural or modified nucleic acids) that do not base pair (hydrogen bond) with corresponding “A” RNA residues of otherwise complementary (target) strand when strands are annealed, yet optionally do base pair with corresponding “B” residues (“B” residues are also RNA, DNA or non-natural or modified nucleic acids). Any of the residues of such agents can optionally be 2'-O-methyl RNA monomers—e.g., alternating positioning of 2'-O-methyl RNA monomers that commences from the 3'-terminal residue of the bottom (second) strand, as shown above, or other patterns of 2'-O-methyl and/or other modifications as described herein can also be used in the above DsiRNA agents.

**[0215]** In addition to the above-exemplified structures, DsiRNAs of the invention can also possess one, two or three additional residues that form further mismatches with the target RNA sequence. Such mismatches can be consecutive, or can be interspersed by nucleotides that form matched base pairs with the target RNA sequence. Where interspersed by nucleotides that form matched base pairs, mismatched residues can be spaced apart from each other within a single strand at an interval of one, two, three, four, five, six, seven or even eight base paired nucleotides between such mismatch-forming residues.

**[0216]** As for the above-described DsiRNAm agents, a preferred location within DsiRNAs for antisense strand nucleotides that form mismatched base pairs with target RNA sequence (yet may or may not form mismatches with corresponding sense strand nucleotides) is within the antisense strand region that is located 3' (downstream) of the antisense strand sequence which is complementary to the projected Ago2 cut site of the DsiRNA (e.g., in FIG. 39, the region of the antisense strand which is labeled as the “mismatch region” is preferred for mismatch-forming residues and happens to be located at positions 13-21 of the antisense strand for the agents shown in FIG. 39). Thus, in one preferred embodiment, the position of a mismatch nucleotide (in relation to the target RNA sequence) of the antisense strand of a DsiRNAm is the nucleotide residue of the antisense strand that is located immediately 3' (downstream) within the antisense strand sequence of the projected Ago2 cleavage site of the corresponding target RNA sequence. In other preferred embodiments, a mismatch nucleotide of the antisense strand of a DsiRNAm (in relation to the target RNA sequence) is positioned at the nucleotide residue of the antisense strand that is located two nucleotides 3' (downstream) of the corresponding projected Ago2 cleavage site, three nucleotides 3' (downstream) of the corresponding projected Ago2 cleavage site, four nucleotides 3' (downstream) of the corresponding projected Ago2 cleavage site, five nucleotides 3' (downstream) of the corresponding projected Ago2 cleavage site, six nucleotides 3' (downstream) of the projected Ago2 cleav-

age site, seven nucleotides 3' (downstream) of the projected Ago2 cleavage site, eight nucleotides 3' (downstream) of the projected Ago2 cleavage site, or nine nucleotides 3' (downstream) of the projected Ago2 cleavage site.

**[0217]** In DsiRNA agents possessing two mismatch-forming nucleotides of the antisense strand (where mismatch-forming nucleotides are mismatch forming in relation to target RNA sequence), mismatches can occur consecutively (e.g. at consecutive positions along the antisense strand nucleotide sequence). Alternatively, nucleotides of the antisense strand that form mismatched base pairs with the target RNA sequence can be interspersed by nucleotides that base pair with the target RNA sequence (e.g., for a DsiRNA possessing mismatch-forming nucleotides at positions 13 and 16 (starting from the 5' terminus (position 1) of the antisense strand of the structure shown in FIG. 39), but not at positions 14 and 15, the mismatched residues of sense strand positions 13 and 16 are interspersed by two nucleotides that form matched base pairs with corresponding residues of the target RNA sequence). For example, two residues of the antisense strand (located within the mismatch-tolerant region of the antisense strand) that form mismatched base pairs with the corresponding target RNA sequence can occur with zero, one, two, three, four or five matched base pairs (with respect to target RNA sequence) located between these mismatch-forming base pairs.

**[0218]** For certain DsiRNAs possessing three mismatch-forming base pairs (mismatch-forming with respect to target RNA sequence), mismatch-forming nucleotides can occur consecutively (e.g., in a triplet along the antisense strand nucleotide sequence). Alternatively, nucleotides of the antisense strand that form mismatched base pairs with the target RNA sequence can be interspersed by nucleotides that form matched base pairs with the target RNA sequence (e.g., for a DsiRNA possessing mismatched nucleotides at positions 13, 14 and 18, but not at positions 15, 16 and 17, the mismatch-forming residues of antisense strand positions 13 and 14 are adjacent to one another, while the mismatch-forming residues of antisense strand positions 14 and 18 are interspersed by three nucleotides that form matched base pairs with corresponding residues of the target RNA). For example, three residues of the antisense strand (located within the mismatch-tolerant region of the antisense strand) that form mismatched base pairs with the corresponding target RNA sequence can occur with zero, one, two, three or four matched base pairs located between any two of these mismatch-forming base pairs.

**[0219]** For certain DsiRNAs possessing four mismatch-forming base pairs (mismatch-forming with respect to target RNA sequence), mismatch-forming nucleotides can occur consecutively (e.g., in a quadruplet along the sense strand nucleotide sequence). Alternatively, nucleotides of the antisense strand that form mismatched base pairs with the target RNA sequence can be interspersed by nucleotides that form matched base pairs with the target RNA sequence (e.g., for a DsiRNA possessing mismatch-forming nucleotides at positions 13, 15, 17 and 18, but not at positions 14 and 16, the mismatch-forming residues of antisense strand positions 17 and 18 are adjacent to one another, while the mismatch-forming residues of antisense strand positions 13 and 15 are interspersed by one nucleotide that forms a matched base pair with the corresponding residue of the target RNA sequence—similarly, the mismatch-forming residues of antisense strand positions 15 and 17 are also interspersed by one nucleotide



that forms a matched base pair with the corresponding residue of the target RNA sequence). For example, four residues of the antisense strand (located within the mismatch-tolerant region of the antisense strand) that form mismatched base pairs with the corresponding target RNA sequence can occur with zero, one, two or three matched base pairs located between any two of these mismatch-forming base pairs.

**[0220]** The above DsiRNAm and other DsiRNA structures are described in order to exemplify certain structures of DsiRNAm and DsiRNA agents. Design of the above DsiRNAm and DsiRNA structures can be adapted to generate, e.g., DsiRNAm forms of a DNA-extended (“DNA handle”) DsiRNA agent shown *infra* (including, e.g., design of mismatch-containing DsiRNAm agents as shown in FIGS. 14-16 and 20-22). As exemplified above, DsiRNAs can also be designed that possess single mismatches (or two, three or four mismatches) between the antisense strand of the DsiRNA and a target sequence, yet optionally can retain perfect complementarity between sense and antisense strand sequences of a DsiRNA.

**[0221]** It is further noted that the DsiRNA agents exemplified *infra* can also possess insertion/deletion (in/del) structures within their double-stranded and/or target RNA-aligned structures. Accordingly, the DsiRNAs of the invention can be designed to possess in/del variations in, e.g., antisense strand sequence as compared to target RNA sequence and/or antisense strand sequence as compared to sense strand sequence, with preferred location(s) for placement of such in/del nucleotides corresponding to those locations described above for positioning of mismatched and/or mismatch-forming base pairs.

**[0222]** In certain embodiments, the “D” residues of any of the above structures include at least one PS-DNA or PS-RNA. Optionally, the “D” residues of any of the above structures include at least one modified nucleotide that inhibits Dicer cleavage.

**[0223]** While the above-described “DNA-extended” DsiRNA agents can be categorized as either “left extended” or “right extended”, DsiRNA agents comprising both left and right-extended DNA-containing sequences within a single agent (e.g., both flanks surrounding a core dsRNA structure are dsDNA extensions) can also be generated and used in similar manner to those described herein for “right-extended” and “left-extended” agents.

**[0224]** In some embodiments, the DsiRNA of the instant invention further comprises a linking moiety or domain that joins the sense and antisense strands of a DNA:DNA-extended DsiRNA agent. Optionally, such a linking moiety domain joins the 3' end of the sense strand and the 5' end of the antisense strand. The linking moiety may be a chemical (non-nucleotide) linker, such as an oligomethylenediol linker, oligoethylene glycol linker, or other art-recognized linker moiety. Alternatively, the linker can be a nucleotide linker, optionally including an extended loop and/or tetraloop.

**[0225]** In one embodiment, the DsiRNA agent has an asymmetric structure, with the sense strand having a 27-base pair length, the antisense strand having a 29-nucleotide length with a 2 base 3'-overhang (and, therefore, the DsiRNA agent possesses a blunt end at the 3' end of the sense strand/5' end of the antisense strand), and with deoxyribonucleotides located at positions 24 and 25 of the sense strand (numbering from position 1 at the 5' of the sense strand) and each base paired with a cognate deoxyribonucleotide of the antisense strand. In

another embodiment, this DsiRNA agent has an asymmetric structure further containing 2 deoxyribonucleotides at the 3' end of the sense strand.

**[0226]** In another embodiment, the DsiRNA agent has an asymmetric structure, with the sense strand having a 30-nucleotide length, the antisense strand having a 28-nucleotide length, with a 2 nucleotide 3' overhang positioned at the 3' end of the sense strand. The 3' end of the antisense strand and 5' end of the sense strand of this DsiRNA agent form a blunt end, and starting from position 1 at the 5' terminus of the sense strand, positions 1-5 are deoxyribonucleotides that hybridize to form a duplex with cognate deoxyribonucleotides of the 3' end region of the antisense strand. Optionally, starting from position 1 at the 5' end of the antisense strand, positions 11-21 of the antisense strand (in certain embodiments, positions 13-21) harbor one or more nucleotides that either form a mismatch base pairing with the corresponding nucleotide of the sense strand, or with the corresponding nucleotide of the target RNA sequence when the antisense strand and the target RNA sequence hybridize to form a duplex, or with both sense strand and target RNA sequence. Optionally, the ultimate and penultimate nucleotides of the 5' terminus of the sense strand and the ultimate and penultimate nucleotides of the 3' end of the antisense strand comprise one or more phosphorothioates (optionally, the two antisense strand deoxyribonucleotides, the two sense strand deoxyribonucleotides, or all 4 deoxyribonucleotides constituting the ultimate and penultimate residues of both the 5' end of the sense strand and the 3' end of the antisense strand possess phosphorothioates).

#### Modification of DsiRNAs

**[0227]** One major factor that inhibits the effect of double stranded RNAs (“dsRNAs”) is the degradation of dsRNAs (e.g., siRNAs and DsiRNAs) by nucleases. A 3'-exonuclease is the primary nuclease activity present in serum and modification of the 3'-ends of antisense DNA oligonucleotides is crucial to prevent degradation (Eder et al., 1991). An RNase-T family nuclease has been identified called ERI-1 which has 3' to 5' exonuclease activity that is involved in regulation and degradation of siRNAs (Kennedy et al., 2004; Hong et al., 2005). This gene is also known as Thex1 (NM\_02067) in mice or THEX1 (NM\_153332) in humans and is involved in degradation of histone mRNA; it also mediates degradation of 3'-overhangs in siRNAs, but does not degrade duplex RNA (Yang et al., 2006). It is therefore reasonable to expect that 3'-end-stabilization of dsRNAs, including the DsiRNAs of the instant invention, will improve stability.

**[0228]** XRN1 (NM\_019001) is a 5' to 3' exonuclease that resides in P-bodies and has been implicated in degradation of mRNA targeted by miRNA (Rehwinkel et al., 2005) and may also be responsible for completing degradation initiated by internal cleavage as directed by a siRNA. XRN2 (NM\_012255) is a distinct 5' to 3' exonuclease that is involved in nuclear RNA processing. Although not currently implicated in degradation or processing of siRNAs and miRNAs, these both are known nucleases that can degrade RNAs and may also be important to consider.

**[0229]** RNase A is a major endonuclease activity in mammals that degrades RNAs. It is specific for ssRNA and cleaves at the 3'-end of pyrimidine bases. SiRNA degradation products consistent with RNase A cleavage can be detected by mass spectrometry after incubation in serum (Turner et al., 2007). The 3'-overhangs enhance the susceptibility of siR-

NAs to RNase degradation. Depletion of RNase A from serum reduces degradation of siRNAs; this degradation does show some sequence preference and is worse for sequences having poly A/U sequence on the ends (Haupenthal et al., 2006). This suggests the possibility that lower stability regions of the duplex may “breathe” and offer transient single-stranded species available for degradation by RNase A. RNase A inhibitors can be added to serum and improve siRNA longevity and potency (Haupenthal et al., 2007).

**[0230]** In 21mers, phosphorothioate or boranophosphate modifications directly stabilize the internucleoside phosphate linkage. Boranophosphate modified RNAs are highly nuclease resistant, potent as silencing agents, and are relatively non-toxic. Boranophosphate modified RNAs cannot be manufactured using standard chemical synthesis methods and instead are made by *in vitro* transcription (IVT) (Hall et al., 2004 and Hall et al., 2006). Phosphorothioate (PS) modifications can be readily placed in an RNA duplex at any desired position and can be made using standard chemical synthesis methods, though the ability to use such modifications within an RNA duplex that retains RNA silencing activity can be limited. As shown herein in FIG. 2 (duplex #8), inclusion of a multiple PS-modified deoxyribonucleotide residues in a tandem series configuration that base paired with a cognate tandem series of PS-modified deoxyribonucleotide residues abolished RNA silencing activity of an agent that was otherwise active with only unmodified deoxyribonucleotides present at these residues. Because PS moieties are likely to require greater spacing when included within an RNA duplex-containing agent in order to retain RNA inhibitory activity, extended DsiRNAs such as those described herein can provide a means of including more PS modifications (either PS-DNA or PS-RNA) within a single DsiRNA agent than would otherwise be available were no such extension used. It is noted, however, that the PS modification shows dose-dependent toxicity, so most investigators have recommended limited incorporation in siRNAs, historically favoring the 3'-ends where protection from nucleases is most important (Harborth et al., 2003; Chiu and Rana, 2003; Braasch et al., 2003; Amarzguoui et al., 2003). More extensive PS modification can be compatible with potent RNAi activity; however, use of sugar modifications (such as 2'-O-methyl RNA) may be superior (Choung et al., 2006).

**[0231]** A variety of substitutions can be placed at the 2'-position of the ribose which generally increases duplex stability ( $T_m$ ) and can greatly improve nuclease resistance. 2'-O-methyl RNA is a naturally occurring modification found in mammalian ribosomal RNAs and transfer RNAs. 2'-O-methyl modification in siRNAs is known, but the precise position of modified bases within the duplex is important to retain potency and complete substitution of 2'-O-methyl RNA for RNA will inactivate the siRNA. For example, a pattern that employs alternating 2'-O-methyl bases can have potency equivalent to unmodified RNA and is quite stable in serum (Choung et al., 2006; Czauderna et al., 2003).

**[0232]** The 2'-fluoro (2'-F) modification is also compatible with dsRNA (e.g., siRNA and DsiRNA) function; it is most commonly placed at pyrimidine sites (due to reagent cost and availability) and can be combined with 2'-O-methyl modification at purine positions; 2'-F purines are available and can also be used. Heavily modified duplexes of this kind can be potent triggers of RNAi *in vitro* (Allerson et al., 2005; Prakash et al., 2005; Kravynack and Baker, 2006) and can improve performance and extend duration of action when

used *in vivo* (Morrissey et al., 2005a; Morrissey et al., 2005b). A highly potent, nuclease stable, blunt 19mer duplex containing alternative 2'-F and 2'-O-Me bases is taught by Allerson. In this design, alternating 2'-O-Me residues are positioned in an identical pattern to that employed by Czauderna, however the remaining RNA residues are converted to 2'-F modified bases. A highly potent, nuclease resistant siRNA employed by Morrissey employed a highly potent, nuclease resistant siRNA *in vivo*. In addition to 2'-O-Me RNA and 2'-F RNA, this duplex includes DNA, RNA, inverted abasic residues, and a 3'-terminal PS internucleoside linkage. While extensive modification has certain benefits, more limited modification of the duplex can also improve *in vivo* performance and is both simpler and less costly to manufacture. Soutschek et al. (2004) employed a duplex *in vivo* and was mostly RNA with two 2'-O-Me RNA bases and limited 3'-terminal PS internucleoside linkages.

**[0233]** Locked nucleic acids (LNAs) are a different class of 2'-modification that can be used to stabilize dsRNA (e.g., siRNA and DsiRNA). Patterns of LNA incorporation that retain potency are more restricted than 2'-O-methyl or 2'-F bases, so limited modification is preferred (Braasch et al., 2003; Grunweller et al., 2003; Elmen et al., 2005). Even with limited incorporation, the use of LNA modifications can improve dsRNA performance *in vivo* and may also alter or improve off target effect profiles (Mook et al., 2007).

**[0234]** Synthetic nucleic acids introduced into cells or live animals can be recognized as “foreign” and trigger an immune response. Immune stimulation constitutes a major class of off-target effects which can dramatically change experimental results and even lead to cell death. The innate immune system includes a collection of receptor molecules that specifically interact with DNA and RNA that mediate these responses, some of which are located in the cytoplasm and some of which reside in endosomes (Marques and Williams, 2005; Schlee et al., 2006). Delivery of siRNAs by cationic lipids or liposomes exposes the siRNA to both cytoplasmic and endosomal compartments, maximizing the risk for triggering a type 1 interferon (IFN) response both *in vitro* and *in vivo* (Morrissey et al., 2005b; Sioud and Sorensen, 2003; Sioud, 2005; Ma et al., 2005). RNAs transcribed within the cell are less immunogenic (Robbins et al., 2006) and synthetic RNAs that are immunogenic when delivered using lipid-based methods can evade immune stimulation when introduced into cells by mechanical means, even *in vivo* (Heidel et al., 2004). However, lipid based delivery methods are convenient, effective, and widely used. Some general strategy to prevent immune responses is needed, especially for *in vivo* application where all cell types are present and the risk of generating an immune response is highest. Use of chemically modified RNAs may solve most or even all of these problems.

**[0235]** Although certain sequence motifs are clearly more immunogenic than others, it appears that the receptors of the innate immune system in general distinguish the presence or absence of certain base modifications which are more commonly found in mammalian RNAs than in prokaryotic RNAs. For example, pseudouridine, N6-methyl-A, and 2'-O-methyl modified bases are recognized as “self” and inclusion of these residues in a synthetic RNA can help evade immune detection (Kariko et al., 2005). Extensive 2'-modification of a sequence that is strongly immunostimulatory as unmodified RNA can block an immune response when administered to mice intravenously (Morrissey et al., 2005b). However, extensive modi-

fication is not needed to escape immune detection and substitution of as few as two 2'-O-methyl bases in a single strand of a siRNA duplex can be sufficient to block a type 1 IFN response both in vitro and in vivo; modified U and G bases are most effective (Judge et al., 2006). As an added benefit, selective incorporation of 2'-O-methyl bases can reduce the magnitude of off-target effects (Jackson et al., 2006). Use of 2'-O-methyl bases should therefore be considered for all dsRNAs intended for in vivo applications as a means of blocking immune responses and has the added benefit of improving nuclease stability and reducing the likelihood of off-target effects.

**[0236]** Although cell death can result from immune stimulation, assessing cell viability is not an adequate method to monitor induction of IFN responses. IFN responses can be present without cell death, and cell death can result from target knockdown in the absence of IFN triggering (for example, if the targeted gene is essential for cell viability). Relevant cytokines can be directly measured in culture medium and a variety of commercial kits exist which make performing such assays routine. While a large number of different immune effector molecules can be measured, testing levels of IFN- $\alpha$ , TNF- $\alpha$ , and IL-6 at 4 and 24 hours post transfection is usually sufficient for screening purposes. It is important to include a "transfection reagent only control" as cationic lipids can trigger immune responses in certain cells in the absence of any nucleic acid cargo. Including controls for IFN pathway induction should be considered for cell culture work. It is essential to test for immune stimulation whenever administering nucleic acids in vivo, where the risk of triggering IFN responses is highest.

**[0237]** Modifications can be included in the DsiRNA agents of the present invention so long as the modification does not prevent the DsiRNA agent from serving as a substrate for Dicer. Indeed, one surprising finding of the instant invention is that base paired deoxyribonucleotides can be attached to previously described DsiRNA molecules, resulting in enhanced RNAi efficacy and duration, provided that such extension is performed in a region of the extended molecule that does not interfere with Dicer processing (e.g., 3' of the Dicer cleavage site of the sense strand/5' of the Dicer cleavage site of the antisense strand). In one embodiment, one or more modifications are made that enhance Dicer processing of the DsiRNA agent. In a second embodiment, one or more modifications are made that result in more effective RNAi generation. In a third embodiment, one or more modifications are made that support a greater RNAi effect. In a fourth embodiment, one or more modifications are made that result in greater potency per each DsiRNA agent molecule to be delivered to the cell. Modifications can be incorporated in the 3'-terminal region, the 5'-terminal region, in both the 3'-terminal and 5'-terminal region or in some instances in various positions within the sequence. With the restrictions noted above in mind, any number and combination of modifications can be incorporated into the DsiRNA agent. Where multiple modifications are present, they may be the same or different. Modifications to bases, sugar moieties, the phosphate backbone, and their combinations are contemplated. Either 5'-terminus can be phosphorylated.

**[0238]** Examples of modifications contemplated for the phosphate backbone include phosphonates, including methylphosphonate, phosphorothioate, and phosphotriester modifications such as alkylphosphotriesters, and the like. Examples of modifications contemplated for the sugar moiety

include 2'-alkyl pyrimidine, such as 2'-O-methyl, 2'-fluoro, amino, and deoxy modifications and the like (see, e.g., Amarrzguioui et al., 2003). Examples of modifications contemplated for the base groups include abasic sugars, 2-O-alkyl modified pyrimidines, 4-thiouracil, 5-bromouracil, 5-iodouracil, and 5-(3-aminoallyl)-uracil and the like. Locked nucleic acids, or LNA's, could also be incorporated. Many other modifications are known and can be used so long as the above criteria are satisfied. Examples of modifications are also disclosed in U.S. Pat. Nos. 5,684,143, 5,858,988 and 6,291,438 and in U.S. published patent application No. 2004/0203145 A1. Other modifications are disclosed in Herdewijn (2000), Eckstein (2000), Rusckowski et al. (2000), Stein et al. (2001); Vorobjev et al. (2001).

**[0239]** One or more modifications contemplated can be incorporated into either strand. The placement of the modifications in the DsiRNA agent can greatly affect the characteristics of the DsiRNA agent, including conferring greater potency and stability, reducing toxicity, enhance Dicer processing, and minimizing an immune response. In one embodiment, the antisense strand or the sense strand or both strands have one or more 2'-O-methyl modified nucleotides. In another embodiment, the antisense strand contains 2'-O-methyl modified nucleotides. In another embodiment, the antisense strand contains a 3' overhang that is comprised of 2'-O-methyl modified nucleotides. The antisense strand could also include additional 2'-O-methyl modified nucleotides.

**[0240]** In certain embodiments of the present invention, the DsiRNA agent has one or more properties which enhance its processing by Dicer. According to these embodiments, the DsiRNA agent has a length sufficient such that it is processed by Dicer to produce an active siRNA and at least one of the following properties: (i) the DsiRNA agent is asymmetric, e.g., has a 3' overhang on the antisense strand and (ii) the DsiRNA agent has a modified 3' end on the sense strand to direct orientation of Dicer binding and processing of the dsRNA region to an active siRNA. In certain such embodiments, the presence of one or more base paired deoxyribonucleotides in a region of the sense strand that is 3' to the projected site of Dicer enzyme cleavage and corresponding region of the antisense strand that is 5' of the projected site of Dicer enzyme cleavage can also serve to orient such a molecule for appropriate directionality of Dicer enzyme cleavage.

**[0241]** In certain embodiments, the length of the dsDNA region (or length of the region comprising DNA:DNA base pairs) is 1-50 base pairs, optionally 2-30 base pairs, preferably 2-20 base pairs, and more preferably 2-15 base pairs. Thus, a DNA:DNA-extended DsiRNA of the instant invention may possess a dsDNA region that is 1, 2, 3, 4, 5, 6, 7, 8, 9, 10, 11, 12, 13, 14, 15, 16, 17, 18, 19, 20, 21, 22, 23, 24, 25, 26, 27, 28, 29, 30, 31, 32, 33, 34, 35, 36, 37, 38, 39, 40, 41, 42, 43, 44, 45, 46, 47, 48, 49, 50 or more (e.g., 51, 52, 53, 54, 55, 56, 57, 58, 59, 60 or more) base pairs in length.

**[0242]** In some embodiments, the longest strand in the dsNA comprises 29-43 nucleotides. In one embodiment, the DsiRNA agent is asymmetric such that the 3' end of the sense strand and 5' end of the antisense strand form a blunt end, and the 3' end of the antisense strand overhangs the 5' end of the sense strand. In certain embodiments, the 3' overhang of the antisense strand is 1-10 nucleotides, and optionally is 1-4 nucleotides, for example 2 nucleotides. Both the sense and the antisense strand may also have a 5' phosphate.

**[0243]** In certain embodiments, the sense strand of a DsiRNA of the invention that comprises base paired deoxyribonucleotide residues has a total length of between 26 nucleotides and 39 or more nucleotides (e.g., the sense strand possesses a length of 26, 27, 28, 29, 30, 31, 32, 33, 34, 35, 36, 37, 38, 39, 40, 41, 42, 43, 44, 45, 46, 47, 48, 49, 50 or more (e.g., 51, 52, 53, 54, 55, 56, 57, 58, 59, 60 or more) nucleotides). In certain embodiments, the length of the sense strand is between 26 nucleotides and 39 nucleotides, optionally between 27 and 35 nucleotides, or, optionally, between 27 and 33 nucleotides in length. In related embodiments, the antisense strand has a length of between 27 and 43 or more nucleotides (e.g., the sense strand possesses a length of 26, 27, 28, 29, 30, 31, 32, 33, 34, 35, 36, 37, 38, 39, 40, 41, 42, 43, 44, 45, 46, 47, 48, 49, 50 or more (e.g., 51, 52, 53, 54, 55, 56, 57, 58, 59, 60 or more) nucleotides). In certain such embodiments, the antisense strand has a length of between 27 and 43 nucleotides in length, or between 27 and 39 nucleotides in length, or between 27 and 35 nucleotides in length, or between 28 and 37 nucleotides in length, or, optionally, between 29 and 35 nucleotides in length.

**[0244]** In certain embodiments, the presence of one or more base paired deoxyribonucleotides in a region of the sense strand that is 3' of the projected site of Dicer enzyme cleavage and corresponding region of the antisense strand that is 5' of the projected site of Dicer enzyme cleavage can serve to direct Dicer enzyme cleavage of such a molecule. While certain exemplified agents of the invention possess a sense strand deoxyribonucleotide that is located at position 24 or more 3' when counting from position 1 at the 5' end of the sense strand, and having this position 24 or more 3' deoxyribonucleotide of the sense strand base pairing with a cognate deoxyribonucleotide of the antisense strand, in some embodiments, it is also possible to direct Dicer to cleave a shorter product, e.g., a 19mer or a 20mer via inclusion of deoxyribonucleotide residues at, e.g., position 20 of the sense strand. Such a position 20 deoxyribonucleotide base pairs with a corresponding deoxyribonucleotide of the antisense strand, thereby directing Dicer-mediated excision of a 19mer as the most prevalent Dicer product (it is noted that the antisense strand can also comprise one or two deoxyribonucleotide residues immediately 3' of the antisense residue that base pairs with the position 20 deoxyribonucleotide residue of the sense strand in such embodiments, to further direct Dicer cleavage of the antisense strand). In such embodiments, the double-stranded DNA region (which is inclusive of modified nucleic acids that block Dicer cleavage) will generally possess a length of greater than 1 or 2 base pairs (e.g., 3 to 5 base pairs or more), in order to direct Dicer cleavage to generate what is normally a non-preferred length of Dicer cleavage product. A parallel approach can also be taken to direct Dicer excision of 20mer siRNAs, with the positioning of the first deoxyribonucleotide residue of the sense strand (when surveying the sense strand from position 1 at the 5' terminus of the sense strand) occurring at position 21.

**[0245]** In certain embodiments, the sense strand of the DsiRNA agent is modified for Dicer processing by suitable modifiers located at the 3' end of the sense strand, i.e., the DsiRNA agent is designed to direct orientation of Dicer binding and processing via sense strand modification. Suitable modifiers include nucleotides such as deoxyribonucleotides, dideoxyribonucleotides, acyclonucleotides and the like and sterically hindered molecules, such as fluorescent molecules and the like. Acyclonucleotides substitute a 2-hydroxy-

ethoxymethyl group for the 2'-deoxyribofuranosyl sugar normally present in dNMPs. Other nucleotide modifiers could include 3'-deoxyadenosine (cordycepin), 3'-azido-3'-deoxythymidine (AZT), 2',3'-dideoxyinosine (ddI), 2',3'-dideoxy-3'-thiacytidine (3TC), 2',3'-didehydro-2',3'-dideoxythymidine (d4T) and the monophosphate nucleotides of 3'-azido-3'-deoxythymidine (AZT), 2',3'-dideoxy-3'-thiacytidine (3TC) and 2',3'-didehydro-2',3'-dideoxythymidine (d4T). In one embodiment, deoxyribonucleotides are used as the modifiers. When nucleotide modifiers are utilized, 1-3 nucleotide modifiers, or 2 nucleotide modifiers are substituted for the ribonucleotides on the 3' end of the sense strand. When sterically hindered molecules are utilized, they are attached to the ribonucleotide at the 3' end of the antisense strand. Thus, the length of the strand does not change with the incorporation of the modifiers. In another embodiment, the invention contemplates substituting two DNA bases in the DsiRNA agent to direct the orientation of Dicer processing of the antisense strand. In a further embodiment of the present invention, two terminal DNA bases are substituted for two ribonucleotides on the 3'-end of the sense strand forming a blunt end of the duplex on the 3' end of the sense strand and the 5' end of the antisense strand, and a two-nucleotide RNA overhang is located on the 3'-end of the antisense strand. This is an asymmetric composition with DNA on the blunt end and RNA bases on the overhanging end. In certain embodiments of the instant invention, the modified nucleotides (e.g., deoxyribonucleotides) of the penultimate and ultimate positions of the 3' terminus of the sense strand base pair with corresponding modified nucleotides (e.g., deoxyribonucleotides) of the antisense strand (optionally, the penultimate and ultimate residues of the 5' end of the antisense strand in those DsiRNA agents of the instant invention possessing a blunt end at the 3' terminus of the sense strand/5' terminus of the antisense strand).

**[0246]** The sense and antisense strands of a DsiRNA agent of the instant invention anneal under biological conditions, such as the conditions found in the cytoplasm of a cell. In addition, a region of one of the sequences, particularly of the antisense strand, of the DsiRNA agent has a sequence length of at least 19 nucleotides, wherein these nucleotides are in the 21-nucleotide region adjacent to the 3' end of the antisense strand and are sufficiently complementary to a nucleotide sequence of the RNA produced from the target gene to anneal with and/or decrease levels of such a target RNA.

**[0247]** The DsiRNA agent of the instant invention may possess one or more deoxyribonucleotide base pairs located at any positions of sense and antisense strands that are located 3' of the projected Dicer cleavage site of the sense strand and 5' of the projected Dicer cleavage site of the antisense strand. In certain embodiments, one, two, three or all four of positions 24-27 of the sense strand (starting from position 1 at the 5' terminus of the sense strand) are deoxyribonucleotides, each deoxyribonucleotide of which base pairs with a corresponding deoxyribonucleotide of the antisense strand. In certain embodiments, the deoxyribonucleotides of the 5' region of the antisense strand (e.g., the region of the antisense strand located 5' of the projected Dicer cleavage site for a given DsiRNA molecule) are not complementary to the target RNA to which the DsiRNA agent is directed. In related embodiments, the entire region of the antisense strand located 5' of the projected Dicer cleavage site of a DsiRNA agent is not complementary to the target RNA to which the DsiRNA agent is directed. In certain embodiments, the deoxyribonucle-

otides of the antisense strand or the entire region of the antisense strand that is located 5' of the projected Dicer cleavage site of the DsiRNA agent is not sufficiently complementary to the target RNA to enhance annealing of the antisense strand of the DsiRNA to the target RNA when the antisense strand is annealed to the target RNA under conditions sufficient to allow for annealing between the antisense strand and the target RNA (e.g., a "core" antisense strand sequence lacking the DNA-extended region anneals equally well to the target RNA as the same "core" antisense strand sequence also extended with sequence of the DNA-extended region).

**[0248]** The DsiRNA agent may also have one or more of the following additional properties: (a) the antisense strand has a right or left shift from the typical 21mer, (b) the strands may not be completely complementary, i.e., the strands may contain simple mismatch pairings and (c) base modifications such as locked nucleic acid(s) may be included in the 5' end of the sense strand. A "typical" 21mer siRNA is designed using conventional techniques. In one technique, a variety of sites are commonly tested in parallel or pools containing several distinct siRNA duplexes specific to the same target with the hope that one of the reagents will be effective (Ji et al., 2003). Other techniques use design rules and algorithms to increase the likelihood of obtaining active RNAi effector molecules (Schwarz et al., 2003; Khvorova et al., 2003; Ui-Tei et al., 2004; Reynolds et al., 2004; Krol et al., 2004; Yuan et al., 2004; Boese et al., 2005). High throughput selection of siRNA has also been developed (U.S. published patent application No. 2005/0042641 A1). Potential target sites can also be analyzed by secondary structure predictions (Heale et al., 2005). This 21mer is then used to design a right shift to include 3-9 additional nucleotides on the 5' end of the 21mer. The sequence of these additional nucleotides may have any sequence. In one embodiment, the added ribonucleotides are based on the sequence of the target gene. Even in this embodiment, full complementarity between the target sequence and the antisense siRNA is not required.

**[0249]** The first and second oligonucleotides of a DsiRNA agent of the instant invention are not required to be completely complementary. They only need to be substantially complementary to anneal under biological conditions and to provide a substrate for Dicer that produces a siRNA sufficiently complementary to the target sequence. Locked nucleic acids, or LNA's, are well known to a skilled artisan (Elman et al., 2005; Kurreck et al., 2002; Crinelli et al., 2002; Braasch and Corey, 2001; Bondensgaard et al., 2000; Wahlstedt et al., 2000). In one embodiment, an LNA is incorporated at the 5' terminus of the sense strand. In another embodiment, an LNA is incorporated at the 5' terminus of the sense strand in duplexes designed to include a 3' overhang on the antisense strand.

**[0250]** In certain embodiments, the DsiRNA agent of the instant invention has an asymmetric structure, with the sense strand having a 27-base pair length, and the antisense strand having a 29-base pair length with a 2 base 3'-overhang. Such agents optionally may possess between one and four deoxyribonucleotides of the 3' terminal region (specifically, the region 3' of the projected Dicer cleavage site) of the sense strand, at least one of which base pairs with a cognate deoxyribonucleotide of the 5' terminal region (specifically, the region 5' of the projected Dicer cleavage site) of the antisense strand. In other embodiments, the sense strand has a 28-base pair length, and the antisense strand has a 30-base pair length with a 2 base 3'-overhang. Such agents optionally may pos-

sess between one and five deoxyribonucleotides of the 3' terminal region (specifically, the region 3' of the projected Dicer cleavage site) of the sense strand, at least one of which base pairs with a cognate deoxyribonucleotide of the 5' terminal region (specifically, the region 5' of the projected Dicer cleavage site) of the antisense strand. In additional embodiments, the sense strand has a 29-base pair length, and the antisense strand has a 31-base pair length with a 2 base 3'-overhang. Such agents optionally possess between one and six deoxyribonucleotides of the 3' terminal region (specifically, the region 3' of the projected Dicer cleavage site) of the sense strand, at least one of which base pairs with a cognate deoxyribonucleotide of the 5' terminal region (specifically, the region 5' of the projected Dicer cleavage site) of the antisense strand. In further embodiments, the sense strand has a 30-base pair length, and the antisense strand has a 32-base pair length with a 2 base 3'-overhang. Such agents optionally possess between one and seven deoxyribonucleotides of the 3' terminal region (specifically, the region 3' of the projected Dicer cleavage site) of the sense strand, at least one of which base pairs with a cognate deoxyribonucleotide of the 5' terminal region (specifically, the region 5' of the projected Dicer cleavage site) of the antisense strand. In other embodiments, the sense strand has a 31-base pair length, and the antisense strand has a 33-base pair length with a 2 base 3'-overhang. Such agents optionally possess between one and eight deoxyribonucleotides of the 3' terminal region (specifically, the region 3' of the projected Dicer cleavage site) of the sense strand, at least one of which base pairs with a cognate deoxyribonucleotide of the 5' terminal region (specifically, the region 5' of the projected Dicer cleavage site) of the antisense strand. In additional embodiments, the sense strand has a 32-base pair length, and the antisense strand has a 34-base pair length with a 2 base 3'-overhang. Such agents optionally possess between one and nine deoxyribonucleotides of the 3' terminal region (specifically, the region 3' of the projected Dicer cleavage site) of the sense strand, at least one of which base pairs with a cognate deoxyribonucleotide of the 5' terminal region (specifically, the region 5' of the projected Dicer cleavage site) of the antisense strand. In still other embodiments, any of these DsiRNA agents have an asymmetric structure that further contains 2 deoxyribonucleotides at the 3' end of the sense strand in place of two of the ribonucleotides; optionally, these 2 deoxyribonucleotides base pair with cognate deoxyribonucleotides of the antisense strand.

**[0251]** Certain DsiRNA agent compositions containing two separate oligonucleotides can be linked by a third structure. The third structure will not block Dicer activity on the DsiRNA agent and will not interfere with the directed destruction of the RNA transcribed from the target gene. In one embodiment, the third structure may be a chemical linking group. Many suitable chemical linking groups are known in the art and can be used. Alternatively, the third structure may be an oligonucleotide that links the two oligonucleotides of the DsiRNA agent in a manner such that a hairpin structure

is produced upon annealing of the two oligonucleotides making up the dsNA composition. The hairpin structure will not block Dicer activity on the DsiRNA agent and will not interfere with the directed destruction of the target RNA.

**[0252]** In certain embodiments, the DsiRNA agent of the invention has several properties which enhance its processing by Dicer. According to such embodiments, the DsiRNA agent has a length sufficient such that it is processed by Dicer to produce an siRNA and at least one of the following properties: (i) the DsiRNA agent is asymmetric, e.g., has a 3' overhang on the sense strand and (ii) the DsiRNA agent has a modified 3' end on the antisense strand to direct orientation of Dicer binding and processing of the dsRNA region to an active siRNA. According to these embodiments, the longest strand in the DsiRNA agent comprises 25-43 nucleotides. In one embodiment, the sense strand comprises 25-39 nucleotides and the antisense strand comprises 26-43 nucleotides. The resulting dsNA can have an overhang on the 3' end of the sense strand. The overhang is 1-4 nucleotides, such as 2 nucleotides. The antisense or sense strand may also have a 5' phosphate.

**[0253]** In certain embodiments, the sense strand of a DsiRNA agent is modified for Dicer processing by suitable modifiers located at the 3' end of the sense strand, i.e., the DsiRNA agent is designed to direct orientation of Dicer binding and processing. Suitable modifiers include nucleotides such as deoxyribonucleotides, dideoxyribonucleotides, acyclonucleotides and the like and sterically hindered molecules, such as fluorescent molecules and the like. Acyclonucleotides substitute a 2-hydroxyethoxymethyl group for the 2'-deoxyribofuranosyl sugar normally present in dNMPs. Other nucleotide modifiers could include 3'-deoxyadenosine (cordycepin), 3'-azido-3'-deoxythymidine (AZT), 2',3'-dideoxyinosine (ddI), 2',3'-dideoxy-3'-thiacytidine (3TC), 2',3'-didehydro-2',3'-dideoxythymidine (d4T) and the monophosphate nucleotides of 3'-azido-3'-deoxythymidine (AZT), 2',3'-dideoxy-3'-thiacytidine (3TC) and 2',3'-didehydro-2',3'-dideoxythymidine (d4T). In one embodiment, deoxyribonucleotides are used as the modifiers. When nucleotide modifiers are utilized, 1-3 nucleotide modifiers, or 2 nucleotide modifiers are substituted for the ribonucleotides on the 3' end of the sense strand. When sterically hindered molecules are utilized, they are attached to the ribonucleotide at the 3' end of the antisense strand. Thus, the length of the strand does not change with the incorporation of the modifiers. In another embodiment, the invention contemplates substituting two DNA bases in the dsNA to direct the orientation of Dicer processing. In a further embodiment, two terminal DNA bases are located on the 3' end of the sense strand in place of two ribonucleotides forming a blunt end of the duplex on the 5' end of the antisense strand and the 3' end of the sense strand, and a two-nucleotide RNA overhang is located on the 3' end of the antisense strand. This is an asymmetric composition with DNA on the blunt end and RNA bases on the overhanging end.

**[0254]** In certain other embodiments, the antisense strand of a DsiRNA agent is modified for Dicer processing by suitable modifiers located at the 3' end of the antisense strand, i.e., the DsiRNA agent is designed to direct orientation of Dicer binding and processing. Suitable modifiers include nucleotides such as deoxyribonucleotides, dideoxyribonucleotides, acyclonucleotides and the like and sterically hindered molecules, such as fluorescent molecules and the like. Acyclonucleotides substitute a 2-hydroxyethoxymethyl group for

the 2'-deoxyribofuranosyl sugar normally present in dNMPs. Other nucleotide modifiers could include 3'-deoxyadenosine (cordycepin), 3'-azido-3'-deoxythymidine (AZT), 2',3'-dideoxyinosine (ddI), 2',3'-dideoxy-3'-thiacytidine (3TC), 2',3'-didehydro-2',3'-dideoxythymidine (d4T) and the monophosphate nucleotides of 3'-azido-3'-deoxythymidine (AZT), 2',3'-dideoxy-3'-thiacytidine (3TC) and 2',3'-didehydro-2',3'-dideoxythymidine (d4T). In one embodiment, deoxyribonucleotides are used as the modifiers. When nucleotide modifiers are utilized, 1-3 nucleotide modifiers, or 2 nucleotide modifiers are substituted for the ribonucleotides on the 3' end of the antisense strand. When sterically hindered molecules are utilized, they are attached to the ribonucleotide at the 3' end of the antisense strand. Thus, the length of the strand does not change with the incorporation of the modifiers. In another embodiment, the invention contemplates substituting two DNA bases in the dsNA to direct the orientation of Dicer processing. In a further invention, two terminal DNA bases are located on the 3' end of the antisense strand in place of two ribonucleotides forming a blunt end of the duplex on the 5' end of the sense strand and the 3' end of the antisense strand, and a two-nucleotide RNA overhang is located on the 3' end of the sense strand. This is also an asymmetric composition with DNA on the blunt end and RNA bases on the overhanging end.

**[0255]** The sense and antisense strands anneal under biological conditions, such as the conditions found in the cytoplasm of a cell. In addition, a region of one of the sequences, particularly of the antisense strand, of the dsNA has a sequence length of at least 19 nucleotides, wherein these nucleotides are adjacent to the 3' end of antisense strand and are sufficiently complementary to a nucleotide sequence of the target RNA to direct RNA interference.

**[0256]** Additionally, the DsiRNA agent structure can be optimized to ensure that the oligonucleotide segment generated from Dicer's cleavage will be the portion of the oligonucleotide that is most effective in inhibiting gene expression. For example, in one embodiment of the invention, a 27-35-bp oligonucleotide of the DsiRNA agent structure is synthesized wherein the anticipated 21 to 22-bp segment that will inhibit gene expression is located on the 3'-end of the antisense strand. The remaining bases located on the 5'-end of the antisense strand will be cleaved by Dicer and will be discarded. This cleaved portion can be homologous (i.e., based on the sequence of the target sequence) or non-homologous and added to extend the nucleic acid strand. As surprisingly identified in the instant invention, such extension can be performed with base paired DNA residues (double stranded DNA:DNA extensions), resulting in extended DsiRNA agents having improved efficacy or duration of effect than corresponding double stranded RNA:RNA-extended DsiRNA agents.

**[0257]** US 2007/0265220 discloses that 27mer DsiRNAs show improved stability in serum over comparable 21mer siRNA compositions, even absent chemical modification. Modifications of DsiRNA agents, such as inclusion of 2'-O-methyl RNA in the antisense strand, in patterns such as detailed in US 2007/0265220 and in the instant Examples, when coupled with addition of a 5' Phosphate, can improve stability of DsiRNA agents. Addition of 5'-phosphate to all strands in synthetic RNA duplexes may be an inexpensive and physiological method to confer some limited degree of nuclease stability.

**[0258]** The chemical modification patterns of the DsiRNA agents of the instant invention are designed to enhance the efficacy of such agents. Accordingly, such modifications are designed to avoid reducing potency of DsiRNA agents; to avoid interfering with Dicer processing of DsiRNA agents; to improve stability in biological fluids (reduce nuclease sensitivity) of DsiRNA agents; or to block or evade detection by the innate immune system. Such modifications are also designed to avoid being toxic and to avoid increasing the cost or impact the ease of manufacturing the instant DsiRNA agents of the invention.

#### RNA Processing

##### **[0259]** siRNA

**[0260]** The process of siRNA-mediated RNAi is triggered by the presence of long, dsRNA molecules in a cell. During the initiation step of RNAi, these dsRNA molecules are cleaved into 21-23 nucleotide (nt) small-interfering RNA duplexes (siRNAs) by Dicer, a conserved family of enzymes containing two RNase III-like domains (Bernstein et al. 2001; Elbashir et al. 2001). The siRNAs are characterized by a 19-21 base pair duplex region and 2 nucleotide 3' overhangs on each strand. During the effector step of RNAi, the siRNAs become incorporated into a multimeric protein complex called RNA-induced silencing complex (RISC), where they serve as guides to select fully complementary mRNA substrates for degradation. Degradation is initiated by endonucleolytic cleavage of the mRNA within the region complementary to the siRNA. More precisely, the mRNA is cleaved at a position 10 nucleotides from the 5' end of the guiding siRNA (Elbashir et al. 2001 *Genes & Dev.* 15: 188-200; Nykanen et al. 2001 *Cell* 107: 309-321; Martinez et al. 2002 *Cell* 110: 563-574). An endonuclease responsible for this cleavage was identified as Argonaute2 (Ago2; Liu et al. *Science*, 305: 1437-41).

##### miRNA

**[0261]** The majority of human miRNAs (70%)—and presumably the majority of miRNAs of other mammals—are transcribed from introns and/or exons, and approximately 30% are located in intergenic regions (Rodriguez et al., *Genome Res.* 2004, 14(10A), 1902-1910). In human and animal, miRNAs are usually transcribed by RNA polymerase II (Farh et al. *Science* 2005, 310(5755), 1817-1821), and in some cases by pol III (Borchert et al. *Nat. Struct. Mol. Biol.* 2006, 13(12), 1097-1101). Certain viral encoded miRNAs are transcribed by RNA polymerase III (Pfeffer et al. *Nat. Methods* 2005, 2(4), 269-276; Andersson et al. *J. Virol.* 2005, 79(15), 9556-9565), and some are located in the open reading frame of viral gene (Pfeffer et al. *Nat. Methods* 2005, 2(4), 269-276; Samols et al. *J. Virol.* 2005, 79(14), 9301-9305). miRNA transcription results in the production of large monocistronic, bicistronic or polycistronic primary transcripts (pri-miRNAs). A single pri-miRNA may range from approximately 200 nucleotides (nt) to several kilobases (kb) in length and have both a 5' 7-methylguanosine (m7) caps and a 3' poly (A) tail. Characteristically, the mature miRNA sequences are localized to regions of imperfect stem-loop sequences within the pri-miRNAs (Cullen. *Mol. Cell* 2004, 16(6), 861-865).

**[0262]** The first step of miRNA maturation in the nucleus is the recognition and cleavage of the pri-miRNAs by the RNase III Drosha-DGCR8 nuclear microprocessor complex, which releases a ~70 nt hairpin-containing precursor molecule called pre-miRNAs, with a monophosphate at the 5' terminus and a 2-nt overhang with a hydroxyl group at the 3' terminus

(Cai et al. *RNA* 2004, 10(12), 1957-1966; Lee et al. *Nature* 2003, 425(6956), 415-419; Kim *Nat. Rev. Mol. Cell. Biol.* 2005, 6(5), 376-385). The next step is the nuclear transport of the pre-miRNAs out of the nucleus into the cytoplasm by Exportin-5, a carrier protein (Yi et al. *Genes. Dev.* 2003, 17(24), 3011-3016, Bohnsack et al. *RNA* 2004, 10(2), 185-191). Exportin-5 and the GTP-bound form of its cofactor Ran together recognize and bind the 2 nucleotide 3' overhang and the adjacent stem that are characteristics of pre-miRNA (Basyuk et al. *Nucl. Acids Res.* 2003, 31(22), 6593-6597, Zamore *Mol. Cell.* 2001, 8(6), 1158-1160). In the cytoplasm, GTP hydrolysis results in release of the pre-miRNA, which is then processed by a cellular endonuclease III enzyme Dicer (Bohnsack et al.). Dicer was first recognized for its role in generating siRNAs that mediate RNA interference (RNAi). Dicer acts in concert with its cofactors TRBP (Transactivating region binding protein; Chendrimata et al. *Nature* 2005, 436(7051), 740-744) and PACT (interferon-inducible double strand-RNA-dependant protein kinase activator, Lee et al. *EMBO J.* 2006, 25(3), 522-532). These enzymes bind at the 3' 2 nucleotide overhang at the base of the pre-miRNA hairpin and remove the terminal loop, yielding an approximately 21-nt miRNA duplex intermediate with both termini having 5' monophosphates, 3' 2 nucleotide overhangs and 3' hydroxyl groups. The miRNA guide strand, the 5' terminus of which is energetically less stable, is then selected for incorporation into the RISC (RNA-induced silencing complex), while the 'passenger' strand is released and degraded (Maniataki et al. *Genes. Dev.* 2005, 19(24), 2979-2990; Hammond et al. *Nature* 2000, 404(6775), 293-296). The composition of RISC remains incompletely defined, but a key component is a member of the Argonaute (Ago) protein family (Maniataki et al.; Meister et al. *Mol. Cell.* 2004, 15(2), 185-197).

**[0263]** The mature miRNA then directs RISC to complementary mRNA species. If the target mRNA has perfect complementarity to the miRNA-armed RISC, the mRNA will be cleaved and degraded (Zeng et al. *Proc. Natl. Acad. Sci. USA* 2003, 100(17), 9779-9784; Hutvagner et al. *Science* 2002, 297(55 89), 2056-2060). But as the most common situation in mammalian cells, the miRNAs targets mRNAs with imperfect complementarity and suppress their translation, resulting in reduced expression of the corresponding proteins (Yekta et al. *Science* 2004, 304(5670), 594-596; Olsen et al. *Dev. Biol.* 1999, 216(2), 671-680). The 5' region of the miRNA, especially the match between miRNA and target sequence at nucleotides 2-7 or 8 of miRNA (starting from position 1 at the 5' terminus), which is called the seed region, is essentially important for miRNA targeting, and this seed match has also become a key principle widely used in computer prediction of the miRNA targeting (Lewis et al. *Cell* 2005, 120(1), 15-20; Brennecke et al. *PLoS Biol.* 2005, 3(3), e85). miRNA regulation of the miRNA-mRNA duplexes is mediated mainly through multiple complementary sites in the 3' UTRs, but there are many exceptions. miRNAs may also bind the 5' UTR and/or the coding region of mRNAs, resulting in a similar outcome (Lytle et al. *Proc. Natl. Acad. Sci. USA* 2007, 104(23), 9667-9672).

##### RNase H

**[0264]** RNase H is a ribonuclease that cleaves the 3'-O—P bond of RNA in a DNA/RNA duplex to produce 3'-hydroxyl and 5'-phosphate terminated products. RNase H is a non-specific endonuclease and catalyzes cleavage of RNA via a hydrolytic mechanism, aided by an enzyme-bound divalent



metal ion. Members of the RNase H family are found in nearly all organisms, from archaea and prokaryotes to eukaryotes. During DNA replication, RNase H is believed to cut the RNA primers responsible for priming generation of Okazaki fragments; however, the RNase H enzyme may be more generally employed to cleave any DNA:RNA hybrid sequence of sufficient length (e.g., typically DNA:RNA hybrid sequences of 4 or more base pairs in length in mammals).

#### MicroRNA and MicroRNA-Like Therapeutics

**[0265]** MicroRNAs (miRNAs) have been described to act by binding to the 3' UTR of a template transcript, thereby inhibiting expression of a protein encoded by the template transcript by a mechanism related to but distinct from classic RNA interference. Specifically, miRNAs are believed to act by reducing translation of the target transcript, rather than by decreasing its stability. Naturally-occurring miRNAs are typically approximately 22 nt in length. It is believed that they are derived from larger precursors known as small temporal RNAs (stRNAs) approximately 70 nt long.

**[0266]** Interference agents such as siRNAs, and more specifically such as miRNAs, that bind within the 3' UTR (or elsewhere in a target transcript, e.g., in repeated elements of, e.g., Notch and/or transcripts of the Notch family) and inhibit translation may tolerate a larger number of mismatches in the siRNA/template (miRNA/template) duplex, and particularly may tolerate mismatches within the central region of the duplex. In fact, there is evidence that some mismatches may be desirable or required, as naturally occurring stRNAs frequently exhibit such mismatches, as do miRNAs that have been shown to inhibit translation in vitro (Zeng et al., *Molecular Cell*, 9: 1-20). For example, when hybridized with the target transcript, such miRNAs frequently include two stretches of perfect complementarity separated by a region of mismatch. Such a hybridized complex commonly includes two regions of perfect complementarity (duplex portions) comprising nucleotide pairs, and at least a single mismatched base pair, which may be, e.g., G:A, G:U, G:G, A:A, A:C, U:U, U:C, C:C, G:-, A:-, U:-, C:-, etc. Such mismatched nucleotides, especially if present in tandem (e.g., a two, three or four nucleotide area of mismatch) can form a bulge that separates duplex portions which are located on either flank of such a bulge. A variety of structures are possible. For example, the miRNA may include multiple areas of nonidentity (mismatch). The areas of nonidentity (mismatch) need not be symmetrical in the sense that both the target and the miRNA include nonpaired nucleotides. For example, structures have been described in which only one strand includes nonpaired nucleotides (Zeng et al., FIG. 33). Typically the stretches of perfect complementarity within a miRNA agent are at least 5 nucleotides in length, e.g., 6, 7, or more nucleotides in length, while the regions of mismatch may be, for example, 1, 2, 3, or 4 nucleotides in length.

**[0267]** In general, any particular siRNA could function to inhibit gene expression both via (i) the "classical" siRNA pathway, in which stability of a target transcript is reduced and in which perfect complementarity between the siRNA and the target is frequently preferred, and also by (ii) the "alternative" pathway (generally characterized as the miRNA pathway in animals), in which translation of a target transcript is inhibited. Generally, the transcripts targeted by a particular siRNA via mechanism (i) would be distinct from the transcript targeted via mechanism (ii), although it is possible that

a single transcript could contain regions that could serve as targets for both the classical and alternative pathways. (Note that the terms "classical" and "alternative" are used merely for convenience and generally are believed to reflect historical timing of discovery of such mechanisms in animal cells, but do not reflect the importance, effectiveness, or other features of either mechanism.) One common goal of siRNA design has been to target a single transcript with great specificity, via mechanism (i), while minimizing off-target effects, including those effects potentially elicited via mechanism (ii). However, it is among the goals of the instant invention to provide RNA interference agents that possess mismatch residues by design, either for purpose of mimicking the activities of naturally-occurring miRNAs, or to create agents directed against target RNAs for which no corresponding miRNA is presently known, with the inhibitory and/or therapeutic efficacies/potencies of such mismatch-containing DsiRNA agents (e.g., DsiRNAm agents) tolerant of, and indeed possibly enhanced by, such mismatches.

**[0268]** The tolerance of miRNA agents for mismatched nucleotides (and, indeed the existence and natural use of mechanism (ii) above in the cell) suggests the use of miRNAs in manners that are advantageous to and/or expand upon the "classical" use of perfectly complementary siRNAs that act via mechanism (i). Because miRNAs are naturally occurring molecules, there are likely to be distinct advantages in applying miRNAs as therapeutic agents. miRNAs benefit from hundreds of millions of years of evolutionary "fine tuning" of their function. Thus, sequence-specific "off target" effects should not be an issue with naturally occurring miRNAs, nor, by extension, with certain synthetic DsiRNAs of the invention (e.g., DsiRNAm agents) designed to mimic naturally occurring miRNAs. In addition, miRNAs have evolved to modulate the expression of groups of genes, driving both up and down regulation (in certain instances, performing both functions concurrently within a cell with a single miRNA acting promiscuously upon multiple target RNAs), with the result that complex cell functions can be precisely modulated. Such replacement of naturally occurring miRNAs can involve introducing synthetic miRNAs or miRNA mimetics (e.g., certain DsiRNAmms) into diseased tissues in an effort to restore normal proliferation, apoptosis, cell cycle, and other cellular functions that have been affected by down-regulation of one or more miRNAs. In certain instances, reactivation of these miRNA-regulated pathways has produced a significant therapeutic response (e.g., In one study on cardiac hypertrophy, overexpression of miR-133 by adenovirus-mediated delivery of a miRNA expression cassette protected animals from agonist-induced cardiac hypertrophy, whereas reciprocally reduction of miR-133 in wild-type mice by antagomirs caused an increase in hypertrophic markers (Care et al. *Nat. Med.* 13: 613-618)).

**[0269]** To date, more than 600 miRNAs have been identified as encoded within the human genome, with such miRNAs expressed and processed by a combination of proteins in the nucleus and cytoplasm. miRNAs are highly conserved among vertebrates and comprise approximately 2% of all mammalian genes. Since each miRNA appears to regulate the expression of multiple, e.g., two, three, four, five, six, seven, eight, nine or even tens to hundreds of different genes, miRNAs can function as "master-switches", efficiently regulating and coordinating multiple cellular pathways and processes. By coordinating the expression of multiple genes, miRNAs



play key roles in embryonic development, immunity, inflammation, as well as cellular growth and proliferation.

**[0270]** Expression and functional studies suggest that the altered expression of specific miRNAs is critical to a variety of human diseases. Mounting evidence indicates that the introduction of specific miRNAs into disease cells and tissues can induce favorable therapeutic responses (Pappas et al. *Expert Opin Ther Targets*. 12: 115-27). The promise of miRNA therapy is perhaps greatest in cancer due to the apparent role of certain miRNAs as tumor suppressors. The rationale for miRNA-based therapeutics for, e.g., cancer is supported, at least in part, by the following observations:

**[0271]** (1) miRNAs are frequently mis-regulated and expressed at altered levels in diseased tissues when compared to normal tissues. A number of studies have shown altered levels of miRNAs in cancerous tissues relative to their corresponding normal tissues. Often, altered expression is the consequence of genetic mutations that lead to increased or reduced expression of particular miRNAs. Diseases that possess unique miRNA expression signatures can be exploited as diagnostic and prognostic markers, and can be targeted with the DsiRNA (e.g., DsiRNAmms) agents of the invention.

**[0272]** (2) Mis-regulated miRNAs contribute to cancer development by functioning as oncogenes or tumor suppressors. Oncogenes are defined as genes whose over-expression or inappropriate activation leads to oncogenesis. Tumor suppressors are genes that are required to keep cells from being cancerous; the down-regulation or inactivation of tumor suppressors is a common inducer of cancer. Both types of genes represent preferred drug targets, as such targeting can specifically act upon the molecular basis for a particular cancer. Examples of oncogenic miRNAs are miR-155 and miR-17-92: let-7 is an example of a tumor suppressive miRNA.

**[0273]** (3) Administration of miRNA induces a therapeutic response by blocking or reducing tumor growth in pre-clinical animal studies. The scientific literature provides proof-of-concept studies demonstrating that restoring miRNA function can prevent or reduce the growth of cancer cells in vitro and also in animal models. A well-characterized example is the anti-tumor activity of let-7 in models for breast and lung cancer. DsiRNAs (e.g., DsiRNAmms) of the invention which are designed to mimic let-7 can be used to target such cancers, and it is also possible to use the DsiRNA design parameters described herein to generate new DsiRNA (e.g., DsiRNAmms) agents directed against target RNAs for which no counterpart naturally occurring miRNA is known (e.g., repeats within Notch or other transcripts), to screen for therapeutic lead compounds, e.g. agents that are capable of reducing tumor burden in pre-clinical animal models.

**[0274]** (4) A given miRNA controls multiple cellular pathways and therefore may have superior therapeutic activity. Based on their biology, miRNAs can function as “master switches” of the genome, regulating multiple gene products and coordinating multiple pathways. Genes regulated by miRNAs include genes that encode conventional oncogenes and tumor suppressors, many of which are individually pursued as drug targets by the pharmaceutical industry. Thus, miRNA therapeutics could possess activity superior to siRNAs and other forms of lead compounds by targeting multiple disease

and/or cancer-associated genes. Given the observation that mis-regulation of miRNAs is frequently an early event in the process of tumorigenesis, miRNA therapeutics, which replace missing miRNAs, may be the most appropriate therapy.

**[0275]** (5) miRNAs are natural molecules and are therefore less prone to induce non-specific side-effects. Millions of years of evolution helped to develop the regulatory network of miRNAs, fine-tuning the interaction of miRNA with target messenger RNAs. Therefore, miRNAs and miRNA derivatives (e.g., DsiRNAs designed to mimic naturally occurring miRNAs) will have few if any sequence-specific “off-target” effects when applied in the proper context.

**[0276]** The physical characteristics of siRNAs and miRNAs are similar. Accordingly, technologies that are effective in delivering siRNAs (e.g., DsiRNAs of the invention) are likewise effective in delivering synthetic miRNAs (e.g., certain DsiRNAmms of the invention).

#### Conjugation and Delivery of DsiRNA Agents

**[0277]** In certain embodiments, the present invention relates to a method for treating a subject having or at risk of developing a disease or disorder. In such embodiments, the DsiRNA can act as a novel therapeutic agent for controlling the disease or disorder. The method comprises administering a pharmaceutical composition of the invention to the patient (e.g., human), such that the expression, level and/or activity of a target RNA is reduced. The expression, level and/or activity of a polypeptide encoded by the target RNA might also be reduced by a DsiRNA of the instant invention.

**[0278]** In the treatment of a disease or disorder, the DsiRNA can be brought into contact with the cells or tissue exhibiting or associated with a disease or disorder. For example, DsiRNA substantially identical to all or part of a target RNA sequence, may be brought into contact with or introduced into a diseased, disease-associated or infected cell, either in vivo or in vitro. Similarly, DsiRNA substantially identical to all or part of a target RNA sequence may be administered directly to a subject having or at risk of developing a disease or disorder.

**[0279]** Therapeutic use of the DsiRNA agents of the instant invention can involve use of formulations of DsiRNA agents comprising multiple different DsiRNA agent sequences. For example, two or more, three or more, four or more, five or more, etc. of the presently described agents can be combined to produce a formulation that, e.g., targets multiple different regions of one or more target RNA(s). A DsiRNA agent of the instant invention may also be constructed such that either strand of the DsiRNA agent independently targets two or more regions of a target RNA. Use of multifunctional DsiRNA molecules that target more than one region of a target nucleic acid molecule is expected to provide potent inhibition of RNA levels and expression. For example, a single multifunctional DsiRNA construct of the invention can target both conserved and variable regions of a target nucleic acid molecule, thereby allowing down regulation or inhibition of, e.g., different strain variants of a virus, or splice variants encoded by a single target gene.

**[0280]** A DsiRNA agent of the invention can be conjugated (e.g., at its 5' or 3' terminus of its sense or antisense strand) or unconjugated to another moiety (e.g. a non-nucleic acid moiety such as a peptide), an organic compound (e.g., a dye, cholesterol, or the like). Modifying DsiRNA agents in this

way may improve cellular uptake or enhance cellular targeting activities of the resulting DsiRNA agent derivative as compared to the corresponding unconjugated DsiRNA agent, are useful for tracing the DsiRNA agent derivative in the cell, or improve the stability of the DsiRNA agent derivative compared to the corresponding unconjugated DsiRNA agent.

#### RNAi In Vitro Assay to Assess DsiRNA Activity

**[0281]** An in vitro assay that recapitulates RNAi in a cell-free system can optionally be used to evaluate DsiRNA constructs. For example, such an assay comprises a system described by Tuschl et al., 1999, *Genes and Development*, 13, 3191-3197 and Zamore et al., 2000, *Cell*, 101, 25-33, adapted for use with DsiRNA agents directed against target RNA. A *Drosophila* extract derived from syncytial blastoderm is used to reconstitute RNAi activity in vitro. Target RNA is generated via in vitro transcription from an appropriate plasmid using T7 RNA polymerase or via chemical synthesis. Sense and antisense DsiRNA strands (for example 20 uM each) are annealed by incubation in buffer (such as 100 mM potassium acetate, 30 mM HEPES-KOH, pH 7.4, 2 mM magnesium acetate) for 1 minute at 90° C. followed by 1 hour at 37° C., then diluted in lysis buffer (for example 100 mM potassium acetate, 30 mM HEPES-KOH at pH 7.4, 2 mM magnesium acetate). Annealing can be monitored by gel electrophoresis on an agarose gel in TBE buffer and stained with ethidium bromide. The *Drosophila* lysate is prepared using zero to two-hour-old embryos from Oregon R flies collected on yeasted molasses agar that are dechorionated and lysed. The lysate is centrifuged and the supernatant isolated. The assay comprises a reaction mixture containing 50% lysate [vol/vol], RNA (10-50 pM final concentration), and 10% [vol/vol] lysis buffer containing DsiRNA (10 nM final concentration). The reaction mixture also contains 10 mM creatine phosphate, 10 ug/ml creatine phosphokinase, 100 uM GTP, 100 uM UTP, 100 uM CTP, 500 uM ATP, 5 mM DTT, 0.1 U/uL RNasin (Promega), and 100 uM of each amino acid. The final concentration of potassium acetate is adjusted to 100 mM. The reactions are pre-assembled on ice and preincubated at 25° C. for 10 minutes before adding RNA, then incubated at 25° C. for an additional 60 minutes. Reactions are quenched with 4 volumes of 1.25x Passive Lysis Buffer (Promega). Target RNA cleavage is assayed by RT-PCR analysis or other methods known in the art and are compared to control reactions in which DsiRNA is omitted from the reaction.

**[0282]** Alternately, internally-labeled target RNA for the assay is prepared by in vitro transcription in the presence of [ $\alpha$ -32P] CTP, passed over a G50 Sephadex column by spin chromatography and used as target RNA without further purification. Optionally, target RNA is 5'-32P-end labeled using T4 polynucleotide kinase enzyme. Assays are performed as described above and target RNA and the specific RNA cleavage products generated by RNAi are visualized on an autoradiograph of a gel. The percentage of cleavage is determined by PHOSPHOR IMAGER® (autoradiography) quantitation of bands representing intact control RNA or RNA from control reactions without DsiRNA and the cleavage products generated by the assay.

#### Methods of Introducing Nucleic Acids, Vectors, and Host Cells

**[0283]** DsiRNA agents of the invention may be directly introduced into a cell (i.e., intracellularly); or introduced

extracellularly into a cavity, interstitial space, into the circulation of an organism, introduced orally, or may be introduced by bathing a cell or organism in a solution containing the nucleic acid. Vascular or extravascular circulation, the blood or lymph system, and the cerebrospinal fluid are sites where the nucleic acid may be introduced.

**[0284]** The DsiRNA agents of the invention can be introduced using nucleic acid delivery methods known in the art including injection of a solution containing the nucleic acid, bombardment by particles covered by the nucleic acid, soaking the cell or organism in a solution of the nucleic acid, or electroporation of cell membranes in the presence of the nucleic acid. Other methods known in the art for introducing nucleic acids to cells may be used, such as lipid-mediated carrier transport, chemical-mediated transport, and cationic liposome transfection such as calcium phosphate, and the like. The nucleic acid may be introduced along with other components that perform one or more of the following activities: enhance nucleic acid uptake by the cell or otherwise increase inhibition of the target RNA.

**[0285]** A cell having a target RNA may be from the germ line or somatic, totipotent or pluripotent, dividing or non-dividing, parenchyma or epithelium, immortalized or transformed, or the like. The cell may be a stem cell or a differentiated cell. Cell types that are differentiated include adipocytes, fibroblasts, myocytes, cardiomyocytes, endothelium, neurons, glia, blood cells, megakaryocytes, lymphocytes, macrophages, neutrophils, eosinophils, basophils, mast cells, leukocytes, granulocytes, keratinocytes, chondrocytes, osteoblasts, osteoclasts, hepatocytes, and cells of the endocrine or exocrine glands.

**[0286]** Depending on the particular target RNA sequence and the dose of DsiRNA agent material delivered, this process may provide partial or complete loss of function for the target RNA. A reduction or loss of RNA levels or expression (either RNA expression or encoded polypeptide expression) in at least 50%, 60%, 70%, 80%, 90%, 95% or 99% or more of targeted cells is exemplary. Inhibition of target RNA levels or expression refers to the absence (or observable decrease) in the level of RNA or RNA-encoded protein. Specificity refers to the ability to inhibit the target RNA without manifest effects on other genes of the cell. The consequences of inhibition can be confirmed by examination of the outward properties of the cell or organism (as presented below in the examples) or by biochemical techniques such as RNA solution hybridization, nuclease protection, Northern hybridization, reverse transcription, gene expression monitoring with a microarray, antibody binding, enzyme linked immunosorbent assay (ELISA), Western blotting, radioimmunoassay (RIA), other immunoassays, and fluorescence activated cell analysis (FACS). Inhibition of target RNA sequence(s) by the DsiRNA agents of the invention also can be measured based upon the effect of administration of such DsiRNA agents upon measurable phenotypes such as tumor size for cancer treatment, viral load/titer for viral infectious diseases, etc. either in vivo or in vitro. For viral infectious diseases, reductions in viral load or titer can include reductions of, e.g., 50%, 60%, 70%, 80%, 90%, 95% or 99% or more, and are often measured in logarithmic terms, e.g., 10-fold, 100-fold, 1000-fold, 10<sup>5</sup>-fold, 10<sup>6</sup>-fold, 10<sup>7</sup>-fold reduction in viral load or titer can be achieved via administration of the DsiRNA agents of the invention to cells, a tissue, or a subject.

**[0287]** For RNA-mediated inhibition in a cell line or whole organism, expression a reporter or drug resistance gene

whose protein product is easily assayed can be measured. Such reporter genes include acetohydroxyacid synthase (AHAS), alkaline phosphatase (AP), beta galactosidase (LacZ), beta glucuronidase (GUS), chloramphenicol acetyltransferase (CAT), green fluorescent protein (GFP), horseradish peroxidase (HRP), luciferase (Luc), nopaline synthase (NOS), octopine synthase (OCS), and derivatives thereof. Multiple selectable markers are available that confer resistance to ampicillin, bleomycin, chloramphenicol, gentamycin, hygromycin, kanamycin, lincomycin, methotrexate, phosphinothricin, puromycin, and tetracyclin. Depending on the assay, quantitation of the amount of gene expression allows one to determine a degree of inhibition which is greater than 10%, 33%, 50%, 90%, 95% or 99% as compared to a cell not treated according to the present invention.

**[0288]** Lower doses of injected material and longer times after administration of RNA silencing agent may result in inhibition in a smaller fraction of cells (e.g., at least 10%, 20%, 50%, 75%, 90%, or 95% of targeted cells). Quantitation of gene expression in a cell may show similar amounts of inhibition at the level of accumulation of target RNA or translation of target protein. As an example, the efficiency of inhibition may be determined by assessing the amount of gene product in the cell; RNA may be detected with a hybridization probe having a nucleotide sequence outside the region used for the inhibitory DsiRNA, or translated polypeptide may be detected with an antibody raised against the polypeptide sequence of that region.

**[0289]** The DsiRNA agent may be introduced in an amount which allows delivery of at least one copy per cell. Higher doses (e.g., at least 5, 10, 100, 500 or 1000 copies per cell) of material may yield more effective inhibition; lower doses may also be useful for specific applications.

#### RNA Interference Based Therapy

**[0290]** As is known, RNAi methods are applicable to a wide variety of genes in a wide variety of organisms and the disclosed compositions and methods can be utilized in each of these contexts. Examples of genes which can be targeted by the disclosed compositions and methods include endogenous genes which are genes that are native to the cell or to genes that are not normally native to the cell. Without limitation, these genes include oncogenes, cytokine genes, idiotype (Id) protein genes, prion genes, genes that expresses molecules that induce angiogenesis, genes for adhesion molecules, cell surface receptors, proteins involved in metastasis, proteases, apoptosis genes, cell cycle control genes, genes that express EGF and the EGF receptor, multi-drug resistance genes, such as the MDR1 gene.

**[0291]** More specifically, a target mRNA of the invention can specify the amino acid sequence of a cellular protein (e.g., a nuclear, cytoplasmic, transmembrane, or membrane-associated protein). In another embodiment, the target mRNA of the invention can specify the amino acid sequence of an extracellular protein (e.g., an extracellular matrix protein or secreted protein). As used herein, the phrase "specifies the amino acid sequence" of a protein means that the mRNA sequence is translated into the amino acid sequence according to the rules of the genetic code. The following classes of proteins are listed for illustrative purposes: developmental proteins (e.g., adhesion molecules, cyclin kinase inhibitors, Wnt family members, Pax family members, Winged helix family members, Hox family members, cytokines/lymphokines and their receptors, growth/differentiation factors and

their receptors, neurotransmitters and their receptors); oncogene-encoded proteins (e.g., ABLI, BCL1, BCL2, BCL6, CBFA2, CBL, CSFIR, ERBA, ERBB, EBRB2, ETSI, ETSI, ETV6, FGR, FOS, FYN, HCR, HRAS, JUN, KRAS, LCK, LYN, MDM2, MLL, MYB, MYC, MYCLI, MYCN, NRAS, PIM I, PML, RET, SRC, TALI, TCL3, and YES); tumor suppressor proteins (e.g., APC, BRCA1, BRCA2, MADH4, MCC, NF I, NF2, RB I, TP53, and WTI); and enzymes (e.g., ACC synthases and oxidases, ACP desaturases and hydroxylases, ADP-glucose pyrophosphorylases, ATPases, alcohol dehydrogenases, amylases, amyloglucosidases, catalases, cellulases, chalcone synthases, chitinases, cyclooxygenases, decarboxylases, dextrinases, DNA and RNA polymerases, galactosidases, glucanases, glucose oxidases, granule-bound starch synthases, GTPases, helicases, hemicellulases, integrases, inulinases, invertases, isomerases, kinases, lactases, lipases, lipoxygenases, lysozymes, nopaline synthases, octopine synthases, pectinesterases, peroxidases, phosphatases, phospholipases, phosphorylases, phytases, plant growth regulator synthases, polygalacturonases, proteinases and peptidases, pullanases, recombinases, reverse transcripts, RUBISCOs, topoisomerases, and xylanases).

**[0292]** In one aspect, the target mRNA molecule of the invention specifies the amino acid sequence of a protein associated with a pathological condition. For example, the protein may be a pathogen-associated protein (e.g., a viral protein involved in immunosuppression of the host, replication of the pathogen, transmission of the pathogen, or maintenance of the infection), or a host protein which facilitates entry of the pathogen into the host, drug metabolism by the pathogen or host, replication or integration of the pathogen's genome, establishment or spread of infection in the host, or assembly of the next generation of pathogen. Pathogens include RNA viruses such as flaviviruses, picornaviruses, rhabdoviruses, filoviruses, retroviruses, including lentiviruses, or DNA viruses such as adenoviruses, poxviruses, herpes viruses, cytomegaloviruses, hepadnaviruses or others. Additional pathogens include bacteria, fungi, helminths, schistosomes and trypanosomes. Other kinds of pathogens can include mammalian transposable elements. Alternatively, the protein may be a tumor-associated protein or an autoimmune disease-associated protein.

**[0293]** The target gene may be derived from or contained in any organism. The organism may be a plant, animal, protozoa, bacterium, virus or fungus. See e.g., U.S. Pat. No. 6,506,559, incorporated herein by reference.

#### Pharmaceutical Compositions

**[0294]** In certain embodiments, the present invention provides for a pharmaceutical composition comprising the DsiRNA agent of the present invention. The DsiRNA agent sample can be suitably formulated and introduced into the environment of the cell by any means that allows for a sufficient portion of the sample to enter the cell to induce gene silencing, if it is to occur. Many formulations for dsNA are known in the art and can be used so long as the dsNA gains entry to the target cells so that it can act. See, e.g., U.S. published patent application Nos. 2004/0203145 A1 and 2005/0054598 A1. For example, the DsiRNA agent of the instant invention can be formulated in buffer solutions such as phosphate buffered saline solutions, liposomes, micellar structures, and capsids. Formulations of DsiRNA agent with cationic lipids can be used to facilitate transfection of the DsiRNA agent into cells. For example, cationic lipids, such as

lipofectin (U.S. Pat. No. 5,705,188), cationic glycerol derivatives, and polycationic molecules, such as polylysine (published PCT International Application WO 97/30731), can be used. Suitable lipids include Oligofectamine, Lipofectamine (Life Technologies), NC388 (Ribozyme Pharmaceuticals, Inc., Boulder, Colo.), or FuGene 6 (Roche) all of which can be used according to the manufacturer's instructions.

[0295] Such compositions typically include the nucleic acid molecule and a pharmaceutically acceptable carrier. As used herein the language "pharmaceutically acceptable carrier" includes saline, solvents, dispersion media, coatings, antibacterial and antifungal agents, isotonic and absorption delaying agents, and the like, compatible with pharmaceutical administration. Supplementary active compounds can also be incorporated into the compositions.

[0296] A pharmaceutical composition is formulated to be compatible with its intended route of administration. Examples of routes of administration include parenteral, e.g., intravenous, intradermal, subcutaneous, oral (e.g., inhalation), transdermal (topical), transmucosal, and rectal administration. Solutions or suspensions used for parenteral, intradermal, or subcutaneous application can include the following components: a sterile diluent such as water for injection, saline solution, fixed oils, polyethylene glycols, glycerine, propylene glycol or other synthetic solvents; antibacterial agents such as benzyl alcohol or methyl parabens; antioxidants such as ascorbic acid or sodium bisulfite; chelating agents such as ethylenediaminetetraacetic acid; buffers such as acetates, citrates or phosphates and agents for the adjustment of tonicity such as sodium chloride or dextrose. pH can be adjusted with acids or bases, such as hydrochloric acid or sodium hydroxide. The parenteral preparation can be enclosed in ampoules, disposable syringes or multiple dose vials made of glass or plastic.

[0297] Pharmaceutical compositions suitable for injectable use include sterile aqueous solutions (where water soluble) or dispersions and sterile powders for the extemporaneous preparation of sterile injectable solutions or dispersion. For intravenous administration, suitable carriers include physiological saline, bacteriostatic water, Cremophor EL™ (BASF, Parsippany, N.J.) or phosphate buffered saline (PBS). In all cases, the composition must be sterile and should be fluid to the extent that easy syringability exists. It should be stable under the conditions of manufacture and storage and must be preserved against the contaminating action of microorganisms such as bacteria and fungi. The carrier can be a solvent or dispersion medium containing, for example, water, ethanol, polyol (for example, glycerol, propylene glycol, and liquid polyethylene glycol, and the like), and suitable mixtures thereof. The proper fluidity can be maintained, for example, by the use of a coating such as lecithin, by the maintenance of the required particle size in the case of dispersion and by the use of surfactants. Prevention of the action of microorganisms can be achieved by various antibacterial and antifungal agents, for example, parabens, chlorobutanol, phenol, ascorbic acid, thimerosal, and the like. In many cases, it will be preferable to include isotonic agents, for example, sugars, polyalcohols such as mannitol, sorbitol, sodium chloride in the composition. Prolonged absorption of the injectable compositions can be brought about by including in the composition an agent which delays absorption, for example, aluminum monostearate and gelatin.

[0298] Sterile injectable solutions can be prepared by incorporating the active compound in the required amount in

an appropriate solvent with one or a combination of ingredients enumerated above, as required, followed by filtered sterilization. Generally, dispersions are prepared by incorporating the active compound into a sterile vehicle, which contains a basic dispersion medium and the required other ingredients from those enumerated above. In the case of sterile powders for the preparation of sterile injectable solutions, the preferred methods of preparation are vacuum drying and freeze-drying which yields a powder of the active ingredient plus any additional desired ingredient from a previously sterile-filtered solution thereof.

[0299] Oral compositions generally include an inert diluent or an edible carrier. For the purpose of oral therapeutic administration, the active compound can be incorporated with excipients and used in the form of tablets, troches, or capsules, e.g., gelatin capsules. Oral compositions can also be prepared using a fluid carrier for use as a mouthwash. Pharmaceutically compatible binding agents, and/or adjuvant materials can be included as part of the composition. The tablets, pills, capsules, troches and the like can contain any of the following ingredients, or compounds of a similar nature: a binder such as microcrystalline cellulose, gum tragacanth or gelatin; an excipient such as starch or lactose, a disintegrating agent such as alginic acid, Primogel, or corn starch; a lubricant such as magnesium stearate or Sterotes; a glidant such as colloidal silicon dioxide; a sweetening agent such as sucrose or saccharin; or a flavoring agent such as peppermint, methyl salicylate, or orange flavoring.

[0300] For administration by inhalation, the compounds are delivered in the form of an aerosol spray from pressured container or dispenser which contains a suitable propellant, e.g., a gas such as carbon dioxide, or a nebulizer. Such methods include those described in U.S. Pat. No. 6,468,798.

[0301] Systemic administration can also be by transmucosal or transdermal means. For transmucosal or transdermal administration, penetrants appropriate to the barrier to be permeated are used in the formulation. Such penetrants are generally known in the art, and include, for example, for transmucosal administration, detergents, bile salts, and fusidic acid derivatives. Transmucosal administration can be accomplished through the use of nasal sprays or suppositories. For transdermal administration, the active compounds are formulated into ointments, salves, gels, or creams as generally known in the art.

[0302] The compounds can also be prepared in the form of suppositories (e.g., with conventional suppository bases such as cocoa butter and other glycerides) or retention enemas for rectal delivery.

[0303] The compounds can also be administered by transfection or infection using methods known in the art, including but not limited to the methods described in McCaffrey et al. (2002), *Nature*, 418(6893), 38-9 (hydrodynamic transfection); Xia et al. (2002), *Nature Biotechnol.*, 20(10), 1006-10 (viral-mediated delivery); or Putnam (1996), *Am. J. Health Syst. Pharm.* 53(2), 151-160, erratum at *Am. J. Health Syst. Pharm.* 53(3), 325 (1996).

[0304] The compounds can also be administered by any method suitable for administration of nucleic acid agents, such as a DNA vaccine. These methods include gene guns, bio injectors, and skin patches as well as needle-free methods such as the micro-particle DNA vaccine technology disclosed in U.S. Pat. No. 6,194,389, and the mammalian transdermal needle-free vaccination with powder-form vaccine as disclosed in U.S. Pat. No. 6,168,587. Additionally, intranasal

delivery is possible, as described in, inter alia, Hamajima et al. (1998), Clin. Immunol. Immunopathol., 88(2), 205-10. Liposomes (e.g., as described in U.S. Pat. No. 6,472,375) and microencapsulation can also be used. Biodegradable targetable microparticle delivery systems can also be used (e.g., as described in U.S. Pat. No. 6,471,996).

**[0305]** In one embodiment, the active compounds are prepared with carriers that will protect the compound against rapid elimination from the body, such as a controlled release formulation, including implants and microencapsulated delivery systems. Biodegradable, biocompatible polymers can be used, such as ethylene vinyl acetate, polyanhydrides, polyglycolic acid, collagen, polyorthoesters, and polylactic acid. Such formulations can be prepared using standard techniques. The materials can also be obtained commercially from Alza Corporation and Nova Pharmaceuticals, Inc. Liposomal suspensions (including liposomes targeted to infected cells with monoclonal antibodies to viral antigens) can also be used as pharmaceutically acceptable carriers. These can be prepared according to methods known to those skilled in the art, for example, as described in U.S. Pat. No. 4,522,811.

**[0306]** Toxicity and therapeutic efficacy of such compounds can be determined by standard pharmaceutical procedures in cell cultures or experimental animals, e.g., for determining the LD<sub>50</sub> (the dose lethal to 50% of the population) and the ED<sub>50</sub> (the dose therapeutically effective in 50% of the population). The dose ratio between toxic and therapeutic effects is the therapeutic index and it can be expressed as the ratio LD<sub>50</sub>/ED<sub>50</sub>. Compounds which exhibit high therapeutic indices are preferred. While compounds that exhibit toxic side effects may be used, care should be taken to design a delivery system that targets such compounds to the site of affected tissue in order to minimize potential damage to uninfected cells and, thereby, reduce side effects.

**[0307]** The data obtained from the cell culture assays and animal studies can be used in formulating a range of dosage for use in humans. The dosage of such compounds lies preferably within a range of circulating concentrations that include the ED<sub>50</sub> with little or no toxicity. The dosage may vary within this range depending upon the dosage form employed and the route of administration utilized. For any compound used in the method of the invention, the therapeutically effective dose can be estimated initially from cell culture assays. A dose may be formulated in animal models to achieve a circulating plasma concentration range that includes the IC<sub>50</sub> (i.e., the concentration of the test compound which achieves a half-maximal inhibition of symptoms) as determined in cell culture. Such information can be used to more accurately determine useful doses in humans. Levels in plasma may be measured, for example, by high performance liquid chromatography.

**[0308]** As defined herein, a therapeutically effective amount of a nucleic acid molecule (i.e., an effective dosage) depends on the nucleic acid selected. For instance, if a plasmid encoding a DsiRNA agent is selected, single dose amounts in the range of approximately 1 pg to 1000 mg may be administered; in some embodiments, 10, 30, 100, or 1000 pg, or 10, 30, 100, or 1000 ng, or 10, 30, 100, or 1000 µg, or 10, 30, 100, or 1000 mg may be administered. In some embodiments, 1-5 g of the compositions can be administered. The compositions can be administered from one or more times per day to one or more times per week; including once every other day. The skilled artisan will appreciate that certain factors may influence the dosage and timing required to effec-

tively treat a subject, including but not limited to the severity of the disease or disorder, previous treatments, the general health and/or age of the subject, and other diseases present. Moreover, treatment of a subject with a therapeutically effective amount of a protein, polypeptide, or antibody can include a single treatment or, preferably, can include a series of treatments.

**[0309]** It can be appreciated that the method of introducing DsiRNA agents into the environment of the cell will depend on the type of cell and the make up of its environment. For example, when the cells are found within a liquid, one preferable formulation is with a lipid formulation such as in lipofectamine and the DsiRNA agents can be added directly to the liquid environment of the cells. Lipid formulations can also be administered to animals such as by intravenous, intramuscular, or intraperitoneal injection, or orally or by inhalation or other methods as are known in the art. When the formulation is suitable for administration into animals such as mammals and more specifically humans, the formulation is also pharmaceutically acceptable. Pharmaceutically acceptable formulations for administering oligonucleotides are known and can be used. In some instances, it may be preferable to formulate DsiRNA agents in a buffer or saline solution and directly inject the formulated DsiRNA agents into cells, as in studies with oocytes. The direct injection of DsiRNA agents duplexes may also be done. For suitable methods of introducing dsNA (e.g., DsiRNA agents), see U.S. published patent application No. 2004/0203145 A1.

**[0310]** Suitable amounts of a DsiRNA agent must be introduced and these amounts can be empirically determined using standard methods. Typically, effective concentrations of individual DsiRNA agent species in the environment of a cell will be about 50 nanomolar or less, 10 nanomolar or less, or compositions in which concentrations of about 1 nanomolar or less can be used. In another embodiment, methods utilizing a concentration of about 200 picomolar or less, and even a concentration of about 50 picomolar or less, about 20 picomolar or less, about 10 picomolar or less, or about 5 picomolar or less can be used in many circumstances.

**[0311]** The method can be carried out by addition of the DsiRNA agent compositions to any extracellular matrix in which cells can live provided that the DsiRNA agent composition is formulated so that a sufficient amount of the DsiRNA agent can enter the cell to exert its effect. For example, the method is amenable for use with cells present in a liquid such as a liquid culture or cell growth media, in tissue explants, or in whole organisms, including animals, such as mammals and especially humans.

**[0312]** The level or activity of a target RNA can be determined by any suitable method now known in the art or that is later developed. It can be appreciated that the method used to measure a target RNA and/or the expression of a target RNA can depend upon the nature of the target RNA. For example, if the target RNA encodes a protein, the term "expression" can refer to a protein or the RNA/transcript derived from the target RNA. In such instances, the expression of a target RNA can be determined by measuring the amount of RNA corresponding to the target RNA or by measuring the amount of that protein. Protein can be measured in protein assays such as by staining or immunoblotting or, if the protein catalyzes a reaction that can be measured, by measuring reaction rates. All such methods are known in the art and can be used. Where target RNA levels are to be measured, any art-recognized methods for detecting RNA levels can be used (e.g., RT-PCR,

Northern Blotting, etc.). In targeting viral RNAs with the DsiRNA agents of the instant invention, it is also anticipated that measurement of the efficacy of a DsiRNA agent in reducing levels of a target virus in a subject, tissue, in cells, either in vitro or in vivo, or in cell extracts can also be used to determine the extent of reduction of target viral RNA level(s). Any of the above measurements can be made on cells, cell extracts, tissues, tissue extracts or any other suitable source material.

**[0313]** The determination of whether the expression of a target RNA has been reduced can be by any suitable method that can reliably detect changes in RNA levels. Typically, the determination is made by introducing into the environment of a cell undigested DsiRNA such that at least a portion of that DsiRNA agent enters the cytoplasm, and then measuring the level of the target RNA. The same measurement is made on identical untreated cells and the results obtained from each measurement are compared.

**[0314]** The DsiRNA agent can be formulated as a pharmaceutical composition which comprises a pharmacologically effective amount of a DsiRNA agent and pharmaceutically acceptable carrier. A pharmacologically or therapeutically effective amount refers to that amount of a DsiRNA agent effective to produce the intended pharmacological, therapeutic or preventive result. The phrases “pharmacologically effective amount” and “therapeutically effective amount” or simply “effective amount” refer to that amount of an RNA effective to produce the intended pharmacological, therapeutic or preventive result. For example, if a given clinical treatment is considered effective when there is at least a 20% reduction in a measurable parameter associated with a disease or disorder, a therapeutically effective amount of a drug for the treatment of that disease or disorder is the amount necessary to effect at least a 20% reduction in that parameter.

**[0315]** Suitably formulated pharmaceutical compositions of this invention can be administered by any means known in the art such as by parenteral routes, including intravenous, intramuscular, intraperitoneal, subcutaneous, transdermal, airway (aerosol), rectal, vaginal and topical (including buccal and sublingual) administration. In some embodiments, the pharmaceutical compositions are administered by intravenous or intraparenteral infusion or injection.

**[0316]** In general, a suitable dosage unit of dsNA will be in the range of 0.001 to 0.25 milligrams per kilogram body weight of the recipient per day, or in the range of 0.01 to 20 micrograms per kilogram body weight per day, or in the range of 0.01 to 10 micrograms per kilogram body weight per day, or in the range of 0.10 to 5 micrograms per kilogram body weight per day, or in the range of 0.1 to 2.5 micrograms per kilogram body weight per day. Pharmaceutical composition comprising the dsNA can be administered once daily. However, the therapeutic agent may also be dosed in dosage units containing two, three, four, five, six or more sub-doses administered at appropriate intervals throughout the day. In that case, the dsNA contained in each sub-dose must be correspondingly smaller in order to achieve the total daily dosage unit. The dosage unit can also be compounded for a single dose over several days, e.g., using a conventional sustained release formulation which provides sustained and consistent release of the dsNA over a several day period. Sustained release formulations are well known in the art. In this embodiment, the dosage unit contains a corresponding multiple of the daily dose. Regardless of the formulation, the pharmaceutical composition must contain dsNA in a quantity sufficient

to inhibit expression of the target gene in the animal or human being treated. The composition can be compounded in such a way that the sum of the multiple units of dsNA together contain a sufficient dose.

**[0317]** Data can be obtained from cell culture assays and animal studies to formulate a suitable dosage range for humans. The dosage of compositions of the invention lies within a range of circulating concentrations that include the ED<sub>50</sub> (as determined by known methods) with little or no toxicity. The dosage may vary within this range depending upon the dosage form employed and the route of administration utilized. For any compound used in the method of the invention, the therapeutically effective dose can be estimated initially from cell culture assays. A dose may be formulated in animal models to achieve a circulating plasma concentration range of the compound that includes the IC<sub>50</sub> (i.e., the concentration of the test compound which achieves a half-maximal inhibition of symptoms) as determined in cell culture. Such information can be used to more accurately determine useful doses in humans. Levels of dsNA in plasma may be measured by standard methods, for example, by high performance liquid chromatography.

**[0318]** The pharmaceutical compositions can be included in a kit, container, pack, or dispenser together with instructions for administration.

#### Methods of Treatment

**[0319]** The present invention provides for both prophylactic and therapeutic methods of treating a subject at risk of (or susceptible to) a disease or disorder caused, in whole or in part, by the expression of a target RNA and/or the presence of such target RNA (e.g., in the context of a viral infection, the presence of a target RNA of the viral genome, capsid, host cell component, etc.).

**[0320]** “Treatment”, or “treating” as used herein, is defined as the application or administration of a therapeutic agent (e.g., a DsiRNA agent or vector or transgene encoding same) to a patient, or application or administration of a therapeutic agent to an isolated tissue or cell line from a patient, who has the disease or disorder, a symptom of disease or disorder or a predisposition toward a disease or disorder, with the purpose to cure, heal, alleviate, relieve, alter, remedy, ameliorate, improve or affect the disease or disorder, the symptoms of the disease or disorder, or the predisposition toward disease.

**[0321]** In one aspect, the invention provides a method for preventing in a subject, a disease or disorder as described above, by administering to the subject a therapeutic agent (e.g., a DsiRNA agent or vector or transgene encoding same). Subjects at risk for the disease can be identified by, for example, any or a combination of diagnostic or prognostic assays as described herein. Administration of a prophylactic agent can occur prior to the detection of, e.g., viral particles in a subject, or the manifestation of symptoms characteristic of the disease or disorder, such that the disease or disorder is prevented or, alternatively, delayed in its progression.

**[0322]** Another aspect of the invention pertains to methods of treating subjects therapeutically, i.e., alter onset of symptoms of the disease or disorder. These methods can be performed in vitro (e.g., by culturing the cell with the DsiRNA agent) or, alternatively, in vivo (e.g., by administering the DsiRNA agent to a subject).

**[0323]** With regards to both prophylactic and therapeutic methods of treatment, such treatments may be specifically tailored or modified, based on knowledge obtained from the

field of pharmacogenomics. "Pharmacogenomics", as used herein, refers to the application of genomics technologies such as gene sequencing, statistical genetics, and gene expression analysis to drugs in clinical development and on the market. More specifically, the term refers to the study of how a patient's genes determine his or her response to a drug (e.g., a patient's "drug response phenotype", or "drug response genotype"). Thus, another aspect of the invention provides methods for tailoring an individual's prophylactic or therapeutic treatment with either the target RNA molecules of the present invention or target RNA modulators according to that individual's drug response genotype. Pharmacogenomics allows a clinician or physician to target prophylactic or therapeutic treatments to patients who will most benefit from the treatment and to avoid treatment of patients who will experience toxic drug-related side effects.

**[0324]** Therapeutic agents can be tested in an appropriate animal model. For example, a DsiRNA agent (or expression vector or transgene encoding same) as described herein can be used in an animal model to determine the efficacy, toxicity, or side effects of treatment with said agent. Alternatively, a therapeutic agent can be used in an animal model to determine the mechanism of action of such an agent. For example, an agent can be used in an animal model to determine the efficacy, toxicity, or side effects of treatment with such an agent. Alternatively, an agent can be used in an animal model to determine the mechanism of action of such an agent.

**[0325]** The practice of the present invention employs, unless otherwise indicated, conventional techniques of chemistry, molecular biology, microbiology, recombinant DNA, genetics, immunology, cell biology, cell culture and transgenic biology, which are within the skill of the art. See, e.g., Maniatis et al., 1982, *Molecular Cloning* (Cold Spring Harbor Laboratory Press, Cold Spring Harbor, N.Y.); Sambrook et al., 1989, *Molecular Cloning*, 2nd Ed. (Cold Spring Harbor Laboratory Press, Cold Spring Harbor, N.Y.); Sambrook and Russell, 2001, *Molecular Cloning*, 3rd Ed. (Cold Spring Harbor Laboratory Press, Cold Spring Harbor, N.Y.); Ausubel et al., 1992, *Current Protocols in Molecular Biology* (John Wiley & Sons, including periodic updates); Glover, 1985, *DNA Cloning* (IRL Press, Oxford); Anand, 1992; Guthrie and Fink, 1991; Harlow and Lane, 1988, *Antibodies*. (Cold Spring Harbor Laboratory Press, Cold Spring Harbor, N.Y.); Jakoby and Pastan, 1979; *Nucleic Acid Hybridization* (B. D. Hames & S. J. Higgins eds. 1984); *Transcription And Translation* (B. D. Hames & S. J. Higgins eds. 1984); *Culture Of Animal Cells* (R. I. Freshney, Alan R. Liss, Inc., 1987); *Immobilized Cells And Enzymes* (IRL Press, 1986); B. Perbal, *A Practical Guide To Molecular Cloning* (1984); the treatise, *Methods In Enzymology* (Academic Press, Inc., N.Y.); *Gene Transfer Vectors For Mammalian Cells* (J. H. Miller and M. P. Calos eds., 1987, Cold Spring Harbor Laboratory); *Methods In Enzymology*, Vols. 154 and 155 (Wu et al. eds.), *Immunochemical Methods In Cell And Molecular Biology* (Mayer and Walker, eds., Academic Press, London, 1987); *Handbook Of Experimental Immunology*, Volumes I-IV (D. M. Weir and C. C. Blackwell, eds., 1986); Riott, *Essential Immunology*, 6th Edition, Blackwell Scientific Publications, Oxford, 1988; Hogan et al., *Manipulating the Mouse Embryo*, (Cold Spring Harbor Laboratory Press, Cold Spring Harbor, N.Y., 1986); Westerfield, M., *The zebrafish book. A guide for the laboratory use of zebrafish (*Danio rerio*)*, (4th Ed., Univ. of Oregon Press, Eugene, 2000).

**[0326]** Unless otherwise defined, all technical and scientific terms used herein have the same meaning as commonly understood by one of ordinary skill in the art to which this invention belongs. Although methods and materials similar or equivalent to those described herein can be used in the practice or testing of the present invention, suitable methods and materials are described below. All publications, patent applications, patents, and other references mentioned herein are incorporated by reference in their entirety. In case of conflict, the present specification, including definitions, will control. In addition, the materials, methods, and examples are illustrative only and not intended to be limiting.

#### EXAMPLES

**[0327]** The present invention is described by reference to the following Examples, which are offered by way of illustration and are not intended to limit the invention in any manner. Standard techniques well known in the art or the techniques specifically described below were utilized.

##### Example 1

##### Methods

##### Oligonucleotide Synthesis, In Vitro Use

**[0328]** Individual RNA strands were synthesized and HPLC purified according to standard methods (Integrated DNA Technologies, Coralville, Iowa). All oligonucleotides were quality control released on the basis of chemical purity by HPLC analysis and full length strand purity by mass spectrometry analysis. Duplex RNA DsiRNAs were prepared before use by mixing equal quantities of each strand, briefly heating to 100° C. in RNA buffer (IDT) and then allowing the mixtures to cool to room temperature.

##### Oligonucleotide Synthesis, In Vivo Use

**[0329]** Individual RNA strands were synthesized and HPLC purified according to standard methods (OligoFactory, Holliston, Mass.). All oligonucleotides were quality control released on the basis of chemical purity by HPLC analysis and full length strand purity by mass spectrometry analysis. Duplex RNA DsiRNAs were prepared before use by mixing equimolar quantities of each strand, briefly heating to 100° C. in RNA buffer (IDT) and then allowing the mixtures to cool to room temperature.

##### Cell Culture and RNA Transfection

**[0330]** HeLa cells were obtained from ATCC and maintained in Dulbecco's modified Eagle medium (HyClone) supplemented with 10% fetal bovine serum (HyClone) at 37° C. under 5% CO<sub>2</sub>. For RNA transfections of FIG. 2, HeLa cells were seeded overnight in 6-well plates at a density of 4×10<sup>5</sup> cells/well in a final volume of 2 mL. 24 hours later, cells were transfected with the DsiRNA duplexes as specified at a final concentration of 20 nM using Oligofectamine™ (Invitrogen) and following the manufacturer's instructions. Briefly, 8 μL of a 5 μM stock solution of each DsiRNA was mixed with 200 μL of Opti-MEM® I (Invitrogen). In a separate tube, 12 μL of Oligofectamine™ was mixed with 48 μL of Opti-MEM® I. After a 5 minute incubation at room temperature (RT) the DsiRNA and Oligofectamine™ aliquots were combined, gently vortexed, and further incubated for 20 minutes at RT to allow DsiRNA:Oligofectamine™ com-

plexes (transfection mixes) to form. Finally, culture medium was added to bring each transfection mix to a final volume of 2 mL. After a 6 hour incubation, the transfection/culture medium in each well was replaced with fresh culture medium and cells were incubated for an additional 18 hours.

**[0331]** For RNA transfections of FIGS. 3-5, HeLa cells were transfected with DsiRNAs as indicated at a final concentration of 0.1 nM using Lipofectamine™ RNAiMAX (Invitrogen) and following manufacturer's instructions. Briefly, 2.5 µL of a 0.02 µM stock solution of each DsiRNA were mixed with 46.5 µL of Opti-MEM I (Invitrogen) and 1 µL of Lipofectamine™ RNAiMAX. The resulting 50 µL mix was added into individual wells of 12 well plates and incubated for 20 min at RT to allow DsiRNA:Lipofectamine™ RNAiMAX complexes to form. Meanwhile, HeLa cells were trypsinized and resuspended in medium at a final concentration of 367 cells/µL. Finally, 450 µL of the cell suspension were added to each well (final volume 500 µL) and plates were placed into the incubator for 24 hours.

#### RNA Isolation and Analysis, In Vitro Examples

**[0332]** Cells were washed once with 2 mL of PBS, and total RNA was extracted using RNeasy Mini Kit™ (Qiagen) and eluted in a final volume of 30 µL. 1 µg of total RNA was reverse-transcribed using Transcriptor 1<sup>st</sup> Strand cDNA Kit™ (Roche) and random hexamers following manufacturer's instructions. One-thirtieth (0.66 µL) of the resulting cDNA was mixed with 5 µL of iQ™ Multiplex Powermix (Bio-Rad) together with 3.33 µL of H<sub>2</sub>O and 1 µL of a 3 µM mix containing 2 sets of primers and probes specific for human genes HPRT-1 (accession number NM\_000194) and SFRS9 (accession number NM\_003769) genes:

```
Hu HPRT forward primer F517
GACTTTGCTTTCCTTGCTCAG

Hu HPRT reverse primer R591
GGCTTATATCCAACACTTCGTGGG

Hu HPRT probe P554
Cy5-ATGGTCAAGGTCGCAAGCTTGCTGGT-IBFQ

Hu SFRS9 forward primer F569
TGTGCAGAAGGATGGAGT

Hu SFRS9 reverse primer R712
CTGGTGCTTCTCTCAGGATA

Hu SFRS9 probe P644
HEX-TGGAAATATGCCCTGCGTAACTGGA-IBFQ
```

#### In Vivo Sample Preparation and Injection

**[0333]** DsiRNA was formulated in Invivofectamine™ according to manufacturer's protocol (Invitrogen, Carlsbad, Calif.). Briefly, the N/group of mice and body weight of the mice used were determined, then amount of DsiRNA needed for each group of mice treated was calculated. One ml IVF-oligo was enough for 4 mice of 25 g/mouse at 10 mg/kg dosage. One mg DsiRNA was added to one ml Invivofectamine™, and mixed at RT for 30 min on a rotator. 14 ml of 5% glucose was used to dilute formulated IVF-DsiRNA and applied to 50 kDa molecular weight cutoff spin concentrators (Amicon). The spin concentrators were spun at 4000 rpm for ~2 hours at 4 C until the volume of IVF-DsiRNA was

brought down to less than 1 ml. Recovered IVF-DsiRNA was diluted to one ml with 5% glucose and readied for animal injection.

#### Animal Injection and Tissue Harvesting

**[0334]** Animals were subjected to surgical anesthesia by i.p. injection with Ketamine/Xylazine. Each mouse was weighed before injection. Formulated IVF-DsiRNA was injected i.v. at 100 µl/10 g of body weight. After 24 hours, mice were sacrificed by CO<sub>2</sub> inhalation. Tissues for analysis were collected and placed in tubes containing 2 ml RNeasy™ (Qiagen) and rotated at RT for 30 min before incubation at 4° C. overnight. The tissues were stored subsequently at -80° C. until use.

#### Tissue RNA Preparation and Quantitation

**[0335]** About 50-100 mg of tissue pieces were homogenized in 1 ml QIAzol™ (Qiagen) on Tissue Lyser™ (Qiagen). Then total RNA were isolated according to the manufacturer's protocol. Briefly, 0.2 ml Chloroform (Sigma-Aldrich) was added to the QIAzol™ lysates and mixed vigorously by vortexing. After spinning at 14,000 rpm for 15 min at 4° C., aqueous phase was collected and mixed with 0.5 ml of isopropanol. After another centrifugation at 14,000 rpm for 10 min, the RNA pellet was washed once with 75% ethanol and briefly dried. The isolated RNA was resuspended in 100 µl RNase-Free water, and subjected to clean up with RNeasy™ total RNA preparation kit (Qiagen) or SV 96 total RNA Isolation System (Promega) according to manufacturer's protocol.

#### First Strand cDNA Synthesis, In Vivo Examples

**[0336]** 1 µg of total RNA was reverse-transcribed using Transcriptor 1<sup>st</sup> Strand cDNA Kit™ (Roche) and oligo-dT following manufacturer's instructions. One-fortieth (0.66 µL) of the resulting cDNA was mixed with 5 µL of iQ Multiplex Powermix (Bio-Rad) together with 3.33 µL of H<sub>2</sub>O and 1 µL of a 3 µM mix containing 2 sets of primers and probes specific for mouse genes HPRT-1 (accession number NM\_013556) and KRAS (accession number NM\_021284) genes:

```
Mm HPRT forward primer F576
CAAACCTTGGCTTTCCTGGT

Mm HPRT reverse primer R664
CAACAAAGTCTGGCCTGTATC

Mm HPRT probe P616
Cy5-TGGTTAAGGTTGCAAGCTTGCTGGTG-IBFQ

Mm KRAS forward primer F275
CTTTGTGGATGAGTACGACC

Mm KRAS reverse primer R390
CACTGTACTCCTCTTACCT

Mm KRAS probe P297
FAM-ACGATAGAGGACTCCTACAGAAACAAGT-IBFQ
```

#### Quantitative RT-PCR

**[0337]** A CFX96 Real-time System with a C1000 Thermal cycler (Bio-Rad) was used for the amplification reactions. PCR conditions were: 95° C. for 3 min; and then cycling at 95° C., 10 sec; 55° C., 1 min for 40 cycles. Each sample was tested in triplicate. For HPRT Examples, relative HPRT



mRNA levels were normalized to SFRS9 mRNA levels and compared with mRNA levels obtained in control samples treated with the transfection reagent plus a control mismatch duplex, or untreated. For KRAS examples, relative KRAS mRNA levels were normalized to HPRT-1 mRNA levels and compared with mRNA levels obtained in control samples from mice treated with 5% glucose. Data were analyzed using Bio-Rad CFX Manager version 1.0 (in vitro Examples) or 1.5 (in vivo Example) software.

#### Example 2

##### Efficacy of DsiRNA Agents Possessing DNA Duplex Extensions

**[0338]** DsiRNA agents possessing DNA duplex extensions were examined for efficacy of sequence-specific target mRNA inhibition. Specifically, HPRT-targeting DsiRNA duplexes possessing RNA-extended, DNA-extended or mixed DNA- and RNA-extended structures were transfected into HeLa cells at a fixed concentration of 20 nM and HPRT expression levels were measured 24 hours later (FIGS. 2A and 2B). Transfections were performed in duplicate, and each duplicate was assayed in triplicate for HPRT expression by qPCR. Under these conditions (20 nM duplexes, Oligofectamine transfection), HPRT gene expression was reduced by 30-50% by duplexes 1 through 6. Duplex 6 contained DNA substitutions which formed a 10 bp (base pair) region starting at the 5' end of the guide (antisense) strand and gave a final length configuration of 33/35mer. Duplex 7 was identical in length and sequence to duplex 6, but contained only 4 DNA nucleoside modifications in the positions indicated in FIG. 2B. Surprisingly, duplex 7 reduced HPRT expression significantly less than duplex 6, suggesting that Dicer recognizes the extended RNA region between the DNA bases and cleaves the duplex into alternate species of siRNAs. It was also observed that phosphorothioate modification of DNA:DNA-extended regions of DsiRNA (duplex 8) was capable of abolishing the RNA inhibitory activity of DNA-extended DsiRNA agents. It is likely that activity of the duplex 8 agent can be restored by sufficient substitution of PS-DNA moieties with unmodified DNA moieties. Indeed, such "add-back" of unmodified DNA residues to such a duplex underscores an advantage of the invention—the agents of the invention can be made to carry more modifications than non-extended agents while still retaining RNA inhibitory activity, which is an important development in view of the issues that presence of tandem and/or tightly-spaced modified residues can cause (here, complete abolishment of RNA inhibitory activity when tandem, base paired PS-DNAs are present in duplex 8).

#### Example 3

##### Dose-Response Comparison of 27/29Mer Duplexes

**[0339]** To test the efficacy of a DNA duplex-extended DsiRNA at reduced concentrations, a modified duplex targeting HPRT was compared to an optimized 27/29mer duplex in a dose response series of experiments at 10.0 nanomolar (nM), 1.0 nanomolar (nM) and 100 picomolar (100 pM or 0.1 nM) concentrations for knockdown of HPRT mRNA levels in HeLa cells. Duplex DsiRNA 1 was a derivative of a 25/27mer DsiRNA duplex previously reported as active (HPRT-1, Rose et al. *NAR* 2005, Collingwood et al. 2008); however, the present duplex (#1) contained an insertion of two bases in each strand that extended the oligonucleotide duplex to a

27/29mer. Duplex 2 was identical in sequence to duplex 1, but the two base pair insertion and two additional nucleosides of the guide strand (antisense sequence) were synthesized as DNA. Thus, duplex 2 terminated in 4 DNA bp (base pairs) at the 5' end of the guide strand, in contrast to previously reported two base DNA substitutions at the 3' end of the passenger (sense) strand (Rose et al, 2005). Duplex 3 (MM control) was derived from the optimized HPRT-1 duplex, but synthesized with mismatches in relation to the target RNA sequence. The base composition and chemical modification of each strand and the base sequences and overhang or blunt structure at the ends of duplex 3 were held constant relative to the optimized HPRT-1 duplex in order to control for non-targeted chemical effects (see FIG. 5). Baseline HPRT expression in untreated cells was also measured ("C" of FIG. 3A).

**[0340]** Putative Dicer processing products of duplexes 1 and 2 were identical (see FIG. 1A) to one another, and to the Dicer processing products of duplexes shown in FIG. 2B. At 10 nM and 1 nM transfection concentrations, both duplexes 1 and 2 reduced HPRT RNA levels by at least 95%, suggesting that the addition of the double-stranded DNA at the end of Duplex 2 did not interfere with Dicer binding and processing of the duplex into a structure competent to load and direct RISC activity against HPRT mRNA. At 100 pM, duplex 2 reduced HPRT expression by 90% and appeared more than 2-fold more active than duplex 1, which reduced HPRT by approximately 75%.

#### Example 4

##### Comparison of Duplexes Extended by Two, Six and Eight DNA Base Pairs

**[0341]** To investigate the length of double stranded DNA extension that might be introduced into a DsiRNA agent while still enhancing efficacy and/or duration of effect of such a DNA duplex-extended DsiRNA in comparison to a DsiRNA agent having a corresponding length of extended double stranded RNA, a series of double stranded nucleic acids were generated and tested with two base pair, six base pair and eight base pair extensions (the nominal length of such extensions also includes penultimate and ultimate deoxyribonucleotide residues of the 3' terminus of the sense strand that base pair with cognate deoxyribonucleotide residues of the 5' terminus of the antisense strand, resulting in the "DNA 4 bp" duplex #4, the "DNA 8 bp" duplex #5 and the "DNA 10 bp" duplex #6 of FIGS. 4A-4D). Inhibition of gene expression by duplex 3, a 33/35mer comprising an extension comprising a two base pair DNA:RNA double stranded region and a six base pair RNA:RNA double stranded region (see FIGS. 4A-4D) was reduced relative to duplex 1 (a 27/29mer having a two base pair RNA:RNA double stranded extension) and duplex 2 (a 31/33mer having a six base pair RNA:RNA double stranded extension), consistent with previous reports that increasing RNA duplex length lowered RNAi activity. Notably, RNA:RNA-extended duplexes 1, 2 and 3 all showed reduced activity relative to corresponding duplexes 4, 5, and 6, which possessed double stranded DNA:DNA extensions. The greatest difference in activity between the RNA insert/DNA series and the DNA series was observed at 100 pM, but was still detectable at 10 pM (FIGS. 4B and 4C).

**[0342]** The duplexes compared in FIG. 4 were designed to 1) enhance negative effects of promiscuous processing of Dicer-substrate duplexes, if it occurred, and 2) to eliminate

the possibility of RNase H-mediated cleavage of the HPRT mRNA. Duplexes processed in a way that did not yield a canonical 19-23 base long RNA strand, beginning with the 3'-end of the guide (antisense) strands shown in FIG. 4B, would be less likely to direct RISC-mediated reduction in HPRT target mRNA levels. Promiscuous processing of long RNA duplexes (e.g., duplex 3 of FIG. 4D) would yield guide strands that contained mismatches in the seed region, thus reducing RISC activity against the target. Promiscuous processing could also yield RISC loaded with passenger (sense) oligonucleotides. Duplex 3 was significantly less active than shorter RNA species at lower concentrations, and was likely processed into less active siRNA species.

**[0343]** If long duplexes containing DNA (e.g., duplex 6 of FIG. 4D) were differentially degraded and/or incorrectly processed, single stranded oligonucleotides containing up to ten bases of antisense DNA could result. In theory, this DNA portion could activate RNase H to cleave a complementary target mRNA. The DNA portions of duplexes 4, 5, and 6 did not match HPRT mRNA, and thus could not be responsible for the observed reduction in HPRT mRNA. Differential degradation of duplexes prior to cellular uptake, processing by Dicer, or before loading into RISC could also have caused an observed difference in HPRT reduction. Duplex 3 contained an internal substitution of two DNA nucleosides to control for this effect (bases 9 and 10, counting from the 3' end of the passenger strand). If DNA substitutions increased duplex activity by simply stabilizing the duplex against nuclease degradation, duplex 3 should have been more stable than duplexes 1 or 2, and potentially as stable as duplex 4. Instead, duplex 3 reduced HPRT target mRNA levels less effectively than duplexes 1, 2, and 4, indicating that the enhancing effect seen when double stranded DNA:DNA regions were introduced was not simply attributable to enhanced resistance to nuclease degradation. By similar rationale, if DNA base pairs had caused a significant stabilization of the tested duplexes, then increased DNA base pair length should have resulted in progressively enhanced activity across duplexes 4 through 6. However, such progressively increasing DNA lengths did not increase duplex activity.

**[0344]** In view of the above results, it was concluded that DsiRNA agents possessing double stranded DNA:DNA extended regions of two to ten base pairs (where such extensions were located in the region of the sense strand that was 3' of the projected Dicer cleavage site and corresponding region of the antisense strand that was 5' of the projected Dicer cleavage site) constituted effective, and in certain cases, enhanced, RNA inhibitory agents.

#### Example 5

##### Enhanced Efficacy of Double Stranded DNA:DNA-Extended Duplexes at Low Concentration

**[0345]** A series of modified duplexes of increasing length was evaluated for reduction of HPRT mRNA expression at a fixed concentration of 100 pM. Duplex 1 of FIGS. 5A and 5B was an optimized 25/27mer Dicer-substrate containing chemical modifications, a two-base overhang at the 3'-end of the guide (antisense) strand and two DNA substitutions and a blunt end at the 3'-end of the passenger (sense) strand (Collingwood et al. 2008). Bases non-complementary to HPRT mRNA were inserted two bases at a time as either RNA (duplexes 2 through 5) or DNA (duplexes 6 through 9; see

FIGS. 5A and 5B), increasing total duplex configurations from 27/29mers to 33/35mers.

**[0346]** Duplex 1 was more effective at reducing HPRT mRNA levels than any other "optimized" duplex extended by the addition of RNA base pairs (duplexes 2 through 5; FIG. 5A), supporting the concept that longer duplexes were likely processed into one or more less active guide species. All duplexes extended by the addition of DNA base pairs (duplexes 6 through 9; FIG. 5A) were significantly more active than duplexes 2 through 5, and approximately equal in activity to duplex 1.

**[0347]** Duplexes 6 through 9 were indistinguishable in their degree of HPRT mRNA reduction. Thus, the DNA base pair regions were not exerting a nuclease-resistance property that increased RNAi activity (compare duplexes 2 through 5 to each other and to duplex 1). Surprisingly, increasing the length of the DNA portion also did not negatively impact HPRT reduction. All DNA duplexes had equivalent activity and had greater activity than comparable RNA-based duplexes. These results indicated that the DNA insertions of duplexes 2 through 5 limited Dicer activity to production of the canonical guide strand processed out of optimized duplex 1.

#### Example 6

##### Efficacy of Left-Extended DsiRNA Agents, Including DsiRNA Agents Harboring Mismatches ("DsiRNAmms")

**[0348]** To examine whether effective DsiRNA agents can also possess DNA:DNA extensions in the reverse ("flipped") orientation as the above-described "right extended" DsiRNA agents, "left extended" DsiRNA agents were synthesized and tested for inhibitory efficacy via methods as described above. Such "left extended" DsiRNA agents (in the instant case, 30/28mer agents possessing a 5 base pair DNA:DNA extension formed between the 5' terminal region of the sense strand and 3' terminal region of the antisense strand, as shown in FIG. 7) were tested for target RNA inhibitory efficacy in direct comparison with corresponding 28/30mer "right extended" DsiRNA agents. Surprisingly, "left extended" agents were observed to be more potent than "right extended" agents in their inhibition of KRAS target mRNA levels. Also surprising was the fact that mismatch residues could be introduced into both "left extended" and "right extended" DNA:DNA extended DsiRNA agents at certain positions but not others, while retaining inhibition efficacy of such agents. Specifically, DNA:DNA extended "DsiRNAmms" agents (as used herein, the term "DsiRNAmms agent" indicates a DsiRNA agent comprising one or more mismatched base pairs that are positioned at a location other than the two terminal nucleotide residues of either end of either strand) were synthesized to possess mismatched base pairs at the following positions: 12 alone, 14 alone, 16 alone, 14 and 18 together and 12 and 16 together (starting from position 1 as the 5' terminal antisense residue of the projected post-Dicer cleaved DsiRNAmms agent). As shown in FIGS. 8 and 9, DsiRNAmms agents possessing mismatched residues at position 14 alone, position 16 alone and at both positions 14 and 18, were all effective inhibitory agents. Surprisingly, left-extended forms of both "parent" DsiRNAs and DsiRNAmms were initially identified to possess greater inhibition efficacy (at 100 pM transfection levels in HeLa cells) than right extended forms for parent DsiRNA agents and for DsiR-

NAm agents having mismatched residues at position 14 alone, position 16 alone and at both positions 14 and 18 of the antisense strand (when positions are numbered in the 3' direction (meaning from 5' to 3') starting from position 1 at the 5' terminal antisense residue of the predicted post-Dicer cleaved DsiRNA or DsiRNAm agent; see FIG. 8). With the exception of the DsiRNAm agent possessing mismatched residues at both positions 14 and 18 of the antisense strand, the greater efficacy at 100 pM which was initially observed for left-extended as compared to right-extended DsiRNA or DsiRNAm agents was reproducible (FIG. 9).

#### Example 7

##### Location of Phosphorothioate Modifications and DNA Residues within Effective DsiRNA Agents

**[0349]** To test whether DNA:DNA extended sequences of the invention provide extra residues within a DsiRNA agent upon which advantageous modifications might be placed while retaining inhibitory efficacy of the DsiRNA agent, the robustness of DsiRNA agents harboring multiple phosphorothioate-modified bases was examined. Prior studies of phosphorothioate modified siRNA agents have revealed that such agents can be cytotoxic to cells when multiple phosphorothioates are present (Amarzguioui et al. *Nucleic Acids Research*. 31: 589-595), and some siRNA agents possessing phosphorothioate modifications at or near the 5' end of the antisense strand have been observed to have reduced inhibitory activity. As shown in FIG. 10, the DsiRNA agents "DNA 6 bp(2PS)" and "DNA 6 bp(4PS)" exhibited similar target mRNA (HPRT) inhibitory efficacies, demonstrating that the DNA-extended duplex regions of these molecules can be extensively modified without detrimental impact upon these molecules' target RNA inhibitory efficacy.

**[0350]** The patterning of deoxyribonucleotides at or near the projected 5' Dicer cleavage site of the antisense strand within "right-extended" DsiRNA agents of the invention was also examined. As shown in FIG. 10, DsiRNA agents possessing antisense strand deoxyribonucleotides extending from the 5' terminus of the antisense strand all the way to the location adjacent to the 5' terminal nucleotide of the post-Dicer cleaved antisense strand (see agents DP1055P/DP1057G and DP1058P/DP1060G) were effective RNA interference agents. Results for the DP1055P/DP1057G and DP1058P/DP1060G DsiRNA agents were unexpected, as it was previously thought that termination of deoxyribonucleotide inclusion within the 5' end region of the antisense strand should occur at a location 5' within the antisense strand of the most 3' Dicer cleavage site within the sense strand (see agents DP1055P/DP1056G and DP1058P/DP1059G). As also shown in FIG. 10, a left-extended DsiRNA agent was observed to be an effective inhibitory agent, while inclusion of a U:G mismatch within the "seed" region of the antisense strand of this DsiRNA agent was observed to cause a modestly diminished level of inhibitory activity.

**[0351]** The effect of strand-weighted patterns of phosphorothioate modification of "right-extended" DsiRNA agents of the invention was also examined. The phosphorothioate-modified oligonucleotide strands of "right-extended" DsiRNA agents "DNA 6 bp(2PS)" and "DNA 6 bp(4PS)" were reassembled to create the DP1061P/DP1064G and DP1062G/DP1063P DsiRNA agents shown in FIG. 11. Surprisingly, the DP1062G/DP1063P duplex, which presents four phosphorothioate modified deoxyribonucleotides on the

passenger strand and only two phosphorothioate modified deoxyribonucleotides on corresponding guide strand residues, performed as well as or better than the "DNA 6 bp(2PS)" agent, whereas the DP1061P/DP1064G duplex, which harbors four phosphorothioate modified deoxyribonucleotides on the guide strand and only two phosphorothioate modified deoxyribonucleotides on corresponding passenger strand residues, was not as effective an inhibitory molecule. Such results suggest that for the extended regions of DsiRNAs of the invention, phosphorothioate modification patterns that weight such modifications on the passenger strand relative to the guide strand might retain greatest efficacy relative to oppositely weighted patterns.

#### Example 8

##### Comparison of Duplexes Extended by Five, Ten and Twelve DNA or RNA Base Pairs

**[0352]** To investigate further the impact of structural extensions of DsiRNAs, several series of "right-extended" DsiRNAs targeting the KRAS transcript were generated and assessed for target knockdown efficacy in vitro. FIG. 12 depicts the structures of a series of "right-extended" DsiRNAs targeting the "KRAS-200" site within the KRAS transcript. The first duplex of FIG. 12 ("DP1174P/DP1175G" or duplex "01" of corresponding data FIG. 13) is a 25/27mer DsiRNA possessing deoxyribonucleotides at only the ultimate and penultimate 3'-terminal residues of the passenger strand. The second duplex of FIG. 12 ("DP1200P/DP1201G" or duplex "02" of corresponding data FIG. 13) is a 25/27mer DsiRNA possessing deoxyribonucleotides at all passenger strand residues located 3' of the passenger strand projected Dicer cleavage site and at all guide strand residues located 5' of the guide strand projected Dicer cleavage site shown. The third duplex of FIG. 12 ("DP1202P/DP1203G" or duplex "03" of corresponding data FIG. 13) is a 30/32mer DsiRNA possessing a five base pair ribonucleotide sequence insertion relative to the "DP1174P/DP1175G" duplex, as shown (boxed region of the third duplex of FIG. 12). The fourth duplex of FIG. 12 ("DP1204P/DP1205G" or duplex "04" of corresponding data FIG. 13) is a 30/32mer DsiRNA possessing a five base pair deoxyribonucleotide sequence insertion relative to the "DP1200P/DP1201G" duplex, as shown (boxed region of the fourth duplex of FIG. 12). The fifth duplex of FIG. 12 ("DP1206P/DP1207G" or duplex "05" of corresponding data FIG. 13) is a 35/37mer DsiRNA possessing a ten base pair ribonucleotide sequence insertion relative to the "DP1174P/DP1175G" duplex, as shown (boxed region of the fifth duplex of FIG. 12). The sixth duplex of FIG. 12 ("DP1208P/DP1209G" or duplex "06" of corresponding data FIG. 13) is a 35/37mer DsiRNA possessing a ten base pair deoxyribonucleotide sequence insertion relative to the "DP1200P/DP1201G" duplex, as shown (boxed region of the sixth duplex of FIG. 12).

**[0353]** FIG. 13 shows KRAS target gene inhibitory efficacy results for the KRAS-200 site targeting DsiRNAs presented in FIG. 12. As shown in FIG. 13, DsiRNAs possessing RNA duplex or DNA duplex extensions of five or even ten base pairs in length retained robust inhibitory efficacy in vitro (the experiments of FIG. 13 were performed in HeLa cells and involved treatment with 0.1 nM DsiRNA for 24 hours, in duplicate, using RNAiMAX; "13" and "14" correspond to results obtained using RNAiMAX alone and obtained for

untreated cells, respectively; multiplex experiments were performed to assess both KRAS and HPRT1 levels).

**[0354]** FIG. 14 depicts the structures of a series of “right-extended” DsiRNAs targeting the “KRAS-909” site within the KRAS transcript. The first duplex of FIG. 14 (“DP1188P/DP1189G”) is a 25/27mer DsiRNA possessing deoxyribonucleotides at only the ultimate and penultimate 3'-terminal residues of the passenger strand. The second duplex of FIG. 14 (“DP1210P/DP1211G”) is a 25/27mer DsiRNA possessing deoxyribonucleotides at all passenger strand residues located 3' of the passenger strand projected Dicer cleavage site and at all guide strand residues located 5' of the guide strand projected Dicer cleavage site shown. The third duplex of FIG. 14 (“DP1212P/DP1213G”) is a 30/32mer DsiRNA possessing a five base pair ribonucleotide sequence insertion relative to the “DP1188P/DP1189G” duplex, as shown (boxed region of the third duplex of FIG. 14). The fourth duplex of FIG. 14 (“DP1214P/DP1215G”) is a 30/32mer DsiRNA possessing a five base pair deoxyribonucleotide sequence insertion relative to the “DP1210P/DP1211G” duplex, as shown (boxed region of the fourth duplex of FIG. 14). The fifth duplex of FIG. 14 (“DP1216P/DP1217G”) is a 35/37mer DsiRNA possessing a ten base pair ribonucleotide sequence insertion relative to the “DP1188P/DP1189G” duplex, as shown (boxed region of the fifth duplex of FIG. 14). The sixth duplex of FIG. 14 (“DP1218P/DP1219G”) is a 35/37mer DsiRNA possessing a ten base pair deoxyribonucleotide sequence insertion relative to the “DP1210P/DP1211G” duplex, as shown (boxed region of the sixth duplex of FIG. 14).

**[0355]** FIG. 15 shows KRAS target gene inhibitory efficacy results for the KRAS-909 site targeting DsiRNAs presented in FIG. 14. As shown in FIG. 15, while 25/27mer DsiRNAs “1188P/1189G” and 30/32mer “1212P/1213G” showed slightly greater target RNA inhibitory efficacies than other DsiRNAs examined, DsiRNAs possessing RNA duplex or DNA duplex extensions of five or even ten base pairs in length exhibited robust inhibitory efficacies in vitro. (the experiments of FIG. 15 were performed in HeLa cells and involved treatment with 0.1 nM DsiRNA for 24 hours, in duplicate, using RNAiMAX; multiplex experiments were performed to assess both KRAS and HPRT1 levels).

#### Example 9

##### Effect of Numerous Phosphorothioate Modifications within “Extended” DsiRNAs

**[0356]** FIG. 10 demonstrates that deoxyribonucleotide extension of DsiRNA molecules can provide a surface upon which phosphorothioate modification can be performed with little, if any, impact upon target transcript inhibitory efficacy of the phosphorothioate-modified DsiRNA. FIGS. 16-18 depict DsiRNA molecules synthesized for purpose of testing whether even more extensive levels of phosphorothioate modification can be tolerated within extended (here, “right-extended”) DsiRNAs. Specifically, FIG. 16 shows a series of “KRAS-249” site-targeting DsiRNAs, wherein:

**[0357]** the first duplex (“K249M”) is a 25/27mer possessing deoxyribonucleotides at only the penultimate and ultimate residues at the 3'-terminus of the passenger strand, has no phosphorothioate modifications and has a pattern of 2'-O-Methyl modification as shown (underlined residues indicate 2-O-Methyl modified residues).

**[0358]** the second duplex (“K249D”) is a 31/33mer possessing a total of eight deoxyribonucleotide base pairs positioned at the 3'-terminus of the passenger strand/5'-terminus of the guide strand, having no phosphorothioate modifications and having a pattern of 2'-O-Methyl modification as shown.

**[0359]** the third and fourth duplexes (“K249DNA8” and “K249DNA8p”) are 33/35mers possessing exclusively deoxyribonucleotides at all passenger strand residues positioned 3' of the projected Dicer cleavage site shown and at all residues of the guide strand located 5' of the projected Dicer cleavage site shown. 2'-O-Methyl modification patterns were the same as used for the “K249D” DsiRNA described above. The fourth duplex (“K249DNA8p”) possesses phosphorothioate modifications at all nucleotides of the eight base pairs comprising the 3' terminus of the passenger strand/5' terminus of the guide strand.

**[0360]** the fifth and sixth duplexes (“K249DNA12” and “K249DNA12p”) are 37/39mers possessing exclusively deoxyribonucleotides at all passenger strand residues positioned 3' of the projected Dicer cleavage site shown and at all residues of the guide strand located 5' of the projected Dicer cleavage site shown. 2'-O-Methyl modification patterns were the same as used for the “K249D” DsiRNA described above. The sixth duplex (“K249DNA12p”) possesses phosphorothioate modifications at all nucleotides of the twelve base pairs comprising the 3' terminus of the passenger strand/5' terminus of the guide strand.

**[0361]** FIG. 17 shows a series of “KRAS-516” site-targeting DsiRNAs, wherein:

**[0362]** the first and second duplexes (“K516DNA8” and “K516DNA8p”) are 33/35mers possessing exclusively deoxyribonucleotides at all passenger strand residues positioned 3' of the projected Dicer cleavage site shown and at all residues of the guide strand located 5' of the projected Dicer cleavage site shown. 2'-O-Methyl modified nucleotides are shown as underlined residues. The second duplex (“K516DNA8p”) possesses phosphorothioate modifications at all nucleotides of the eight base pairs comprising the 3' terminus of the passenger strand/5' terminus of the guide strand. Notably, a four base pair deoxyribonucleotide sequence of K249 was introduced into these extended DsiRNAs (see boxed region labeled as “K249”).

**[0363]** the third and fourth duplexes (“K516DNA12” and “K516DNA12p”) are 37/39mers possessing exclusively deoxyribonucleotides at all passenger strand residues positioned 3' of the projected Dicer cleavage site shown and at all residues of the guide strand located 5' of the projected Dicer cleavage site shown. 2'-O-Methyl modification patterns were the same as used for the “K516DNA8” and “K516DNA8p” DsiRNAs described above. The fourth duplex (“K516DNA12p”) possesses phosphorothioate modifications at all nucleotides of the twelve base pairs comprising the 3' terminus of the passenger strand/5' terminus of the guide strand. As for “K516DNA8” and “K516DNA8p” DsiRNAs, a four base pair deoxyribonucleotide sequence of K249 was used introduced into these extended DsiRNAs (see boxed region labeled as “K249”).

[0364] FIG. 18 shows a series of “KRAS-909” site-targeting DsiRNAs, wherein:

[0365] the first and second duplexes (“K909DNA8” and “K909DNA8p”) are 33/35mers possessing exclusively deoxyribonucleotides at all passenger strand residues positioned 3' of the projected Dicer cleavage site shown and at all residues of the guide strand located 5' of the projected Dicer cleavage site shown. 2'-O-Methyl modified nucleotides are shown as underlined residues. The second duplex (“K909DNA8p”) possesses phosphorothioate modifications at all nucleotides of the eight base pairs comprising the 3' terminus of the passenger strand/5' terminus of the guide strand. A four base pair deoxyribonucleotide sequence of K249 was also introduced into these extended DsiRNAs (see boxed region labeled as “K249”).

[0366] the third and fourth duplexes (“K909DNA12” and “K909DNA12p”) are 37/39mers possessing exclusively deoxyribonucleotides at all passenger strand residues positioned 3' of the projected Dicer cleavage site shown and at all residues of the guide strand located 5' of the projected Dicer cleavage site shown. 2'-O-Methyl modification patterns were the same as used for the “K909DNA8” and “K909DNA8p” DsiRNAs described above. The fourth duplex (“K909DNA 12p”) possesses phosphorothioate modifications at all nucleotides of the twelve base pairs comprising the 3' terminus of the passenger strand/5' terminus of the guide strand. As for “K909DNA8” and “K909DNA8p” DsiRNAs, a four base pair deoxyribonucleotide sequence of K249 was used introduced into these extended DsiRNAs (see boxed region labeled as “K249”).

[0367] The extended DsiRNAs shown in FIGS. 16-18 were tested for KRAS target transcript inhibitory efficacy in vitro. Data from such experiments is shown in FIG. 19. Surprisingly, both 33/35mer and 37/39mer DNA-extended DsiRNAs exhibited significant inhibitory efficacies (refer to “DNA8” and “DNA 12” results for each of KRAS-249, 516 and 909 target sites in FIG. 19); however, extensive phosphorothioate modification of the DNA-extended region of these DsiRNAs—positioned on both strands of the extended region—reduced inhibitory efficacies (see “DNA8p” and “DNA12p” results for each of KRAS-249, 516 and 909 target sites). Thus, even though a pattern of two or even four successive DNA base pairs harboring phosphorothioate modifications of both strands was observed to show little or no impact upon the efficacy of a DNA-extended DsiRNA (see FIG. 10), FIG. 19 shows that insertion of eight or twelve successive phosphorothioate-modified deoxyribonucleotide base pairs (phosphorothioate modified on both strands) within the “extended” DsiRNAs of the invention can reduce the inhibitory efficacy of such “extended” DsiRNAs.

[0368] In spite of the above results, it is noted that positioning of phosphorothioate modifications on only one strand of the double-stranded extended regions of the extended DsiRNAs of the instant invention has been shown to allow for introduction of longer runs of phosphorothioate modification with no significant loss of efficacy. For example, inclusion of as many as 15 consecutive phosphorothioate modifications upon only one strand of the extended region of an extended DsiRNA has been shown to be tolerated without significant loss of efficacy of such a modified extended DsiRNA (data not shown). Thus, even though the results of FIG. 19 show the impact of including long tracts of phosphorothioate modifi-

cation upon both strands of the extended DsiRNAs of the invention, on the whole, the DNA-containing extended region (s) of the DsiRNAs of the instant invention have been demonstrated to provide a structure upon which extensive advantageous modifications (e.g., phosphorothioate, 2'-O-Methyl or other modification(s) capable of enhancing stability, delivery, efficacy and/or potency of the extended DsiRNAs of the invention) can be introduced without negatively impacting, e.g., the inhibitory efficacy of the extended DsiRNAs of the invention.

#### Example 10

##### Relative Effect of Position and Number of Mismatches Within Non-Seed Regions of DsiRNAs

[0369] In above Example 6, it was demonstrated that introduction of mismatches within the extended DsiRNAs of the invention could create extended “DsiRNAm” agents that possess inhibitory efficacies similar to those of DsiRNAs possessing sequences that are perfectly complementary to target sequence. Notably, it was observed in FIGS. 7-9 that, of the non-seed region mismatch positions examined, the mismatch position (“position 12”) that impacted efficacy the most was also the position located in closest proximity to the projected Ago2 cleavage site of the target strand sequence. Further to these results, the effect of introducing sequence mismatches within 25/27mer DsiRNA nucleotides at non-seed region positions substantially removed from the projected Ago2 cleavage site was examined. FIG. 20 shows the structures of a series of 25/27mer DsiRNAs that were synthesized to assess the impact of introducing one or more mismatch residues (noting that for the DsiRNAm molecules of FIG. 20, mismatches were relative to target sequence only, and not with respect to corresponding DsiRNA passenger strand sequence residues; it is further noted that a “target-mismatched” nucleotide or residue is defined for purpose of the invention as a guide strand nucleotide that forms a mismatch relative to target nucleotide sequence, but that is not necessarily mismatched relative to a corresponding DsiRNA passenger strand sequence nucleotide), with such mismatches starting from either the 3' terminus of the guide strand, or starting from the guide strand position that is complementary to the 5' terminal residue of the passenger strand. As shown in FIG. 21, the 3' terminal region of the guide strand of the tested 25/27mer DsiRNA surprisingly tolerated introduction of one or more target-mismatched nucleotides. Indeed, introduction of between one and three target-mismatched nucleotides commencing from the 3' terminus of the guide strand of the tested DsiRNA elicited no statistically significant impact upon target inhibition efficacy (see duplexes DP1301P/DP1303G, DP1301P/DP1304G and DP1305P/DP1306G), while introduction of four, five or even six target-mismatched nucleotides commencing from the 3' terminus of the guide strand of the tested DsiRNA still resulted in a DsiRNA that retained significant inhibitory activity (see duplexes DP1307P/DP1308G, DP1309P/DP1310G and DP1311P/DP1312G). Introduction of target-mismatched residues within the guide strand that commenced from the guide strand position that is complementary to the 5' terminal residue of the DsiRNA passenger strand yielded results consistent with those observed for introduction of target-mismatched nucleotides commencing from the 3' terminus of the guide strand. Specifically, introduction of between one and four target-mismatched nucleotides com-

mencing from the guide strand position that is complementary to the 5' terminal residue of the DsiRNA passenger strand impacted DsiRNA inhibitory efficacy to approximately the same extent as observed for introduction of between three and six target-mismatched nucleotides commencing from the 3' terminus of the guide strand (consistent with the observed tolerance for the ultimate and penultimate nucleotides of the 3'-terminal guide strand sequence—as well as the guide strand position complementary to the 5' terminal residue of the DsiRNA passenger strand—to target-mismatched nucleotides).

#### Example 11

##### In Vivo Efficacy of DsiRNA Agents, Single Dose Results

**[0370]** DsiRNA agents possessing DNA duplex extensions were examined for in vivo efficacy of sequence-specific target mRNA inhibition. Specifically, unmodified KRAS-targeting DsiRNA “K249” of FIG. 20 (“DP1301P/DP1302G” duplex), 2'-O-Methyl-modified KRAS-targeting DsiRNA “K249M” (first duplex of FIG. 16) and 2'-O-Methyl-modified “right extended” KRAS-targeting DsiRNA “K249D” (second duplex of FIG. 16; denoted as “K249DNA” in FIGS. 22-25) were formulated in InvivoFectamine™ and injected i.v. into CD1 mice at 10 mg/kg. Expression of KRAS in liver, kidney, spleen and lymph node tissues was measured 24 hours post-injection (FIGS. 22-25, respectively; each bar presents results obtained for four mice per treatment group), with real-time PCR (RT-PCR) performed in triplicate to assess KRAS expression. Under these conditions, “right extended” DsiRNA “K249DNA” exhibited statistically significant levels of KRAS target gene inhibition in all tissues examined. Specific KRAS percent inhibition levels observed in such “K249DNA”-treated tissues and p-values associated with these observations were: liver (55%-87%, mean 71%, p=0.010), spleen (92%-98%, mean 94%, P<0.001), kidney (19%-53%, mean 35%, P=0.009) and lymph nodes (47%-81%, mean 59%, P=0.001). Thus, the in vivo efficacy of the extended DsiRNAs of the instant invention were demonstrated across many tissue types.

#### Example 12

##### In Vivo Efficacy of DsiRNA Agents, Multiple Dose Results

**[0371]** DsiRNA agents possessing DNA duplex extensions were examined for in vivo efficacy of sequence-specific target mRNA inhibition in a repeated dose protocol at a lower dosage than that of Example 11. Specifically, 2'-O-Methyl-modified KRAS-targeting DsiRNA “K249M” (first duplex of FIG. 16) and 2'-O-Methyl-modified “right extended” KRAS-targeting DsiRNA “K249D” (second duplex of FIG. 16) were formulated in InvivoFectamine™ and injected i.v. in CD1 mice at 2 mg/kg every 3 days until a total of four doses were administered to each mouse. Expression of KRAS in liver, lung, spleen and kidney tissues was measured 24 hours after the final injection was administered (FIGS. 26-29, respectively; each bar presents results obtained for four mice per treatment group), with real-time PCR (RT-PCR) performed in triplicate to assess KRAS expression. Under these conditions, statistically significant reductions in KRAS levels were observed in liver and spleen tissues of mice administered the “right-extended” DsiRNA “K249D”. Specific KRAS percent

inhibition levels observed in such “K249DNA”-treated tissues and p-values associated with these observations were: liver (46%-90%, mean 78%, p=0.002), spleen (36%-80%, mean 62%, P=0.004), kidney (0%, mean 0%, P=0.814\*\*) and lung (17%-38%, mean 26%, P=0.065\*\*). Thus, the in vivo efficacy of the extended DsiRNAs of the instant invention in a multi-dose (low dose) regimen was demonstrated in liver and spleen tissues.

#### Example 13

##### Further Assessment of In Vivo Efficacy of DsiRNA Agents

**[0372]** Further demonstration of the capability of the extended Dicer substrate agents of the invention to reduce gene expression of specific target genes in vivo is performed via administration of the DsiRNAs of the invention to mice or other mammalian subjects, either systemically (e.g., by i.v. or i.p. injection) or via direct injection of a tissue (e.g., injection of the eye, spinal cord/brain/CNS, etc.). Measurement of additional target RNA levels are performed upon target cells (e.g., RNA levels in liver and/or kidney cells are assayed following injection of mice; eye cells are assayed following ophthalmic injection of subjects; or spinal cord/brain/CNS cells are assayed following direct injection of same of subjects) by standard methods (e.g., Trizol™ preparation (guanidinium thiocyanate-phenol-chloroform) followed by qRT-PCR).

**[0373]** In any such further in vivo experiments, an extended Dicer substrate agent of the invention (e.g., a left-extended or right-extended DsiRNA) can be deemed to be an effective in vivo agent if a statistically significant reduction in RNA levels is observed when administering an extended Dicer substrate agent of the invention, as compared to an appropriate control (e.g., a vehicle alone control, a randomized duplex control, a duplex directed to a different target RNA control, etc.). Generally, if the p-value (e.g., generated via 1 tailed, unpaired T-test) assigned to such comparison is less than 0.05, an extended Dicer substrate agent (e.g., left-extended or right-extended DsiRNA agent) of the invention is deemed to be an effective RNA interference agent. Alternatively, the p-value threshold below which to classify an extended Dicer substrate agent of the invention as an effective RNA interference agent can be set, e.g. at 0.01, 0.001, etc., in order to provide more stringent filtering, identify more robust differences, and/or adjust for multiple hypothesis testing, etc. Absolute activity level limits can also be set to distinguish between effective and non-effective extended Dicer substrate agents. For example, in certain embodiments, an effective extended Dicer substrate agent of the invention is one that not only shows a statistically significant reduction of target RNA levels in vivo but also exerts, e.g., at least an approximately 10% reduction, approximately 15% reduction, at least approximately 20% reduction, approximately 25% reduction, approximately 30% reduction, etc. in target RNA levels in the tissue or cell that is examined, as compared to an appropriate control. Further in vivo efficacy testing of the extended Dicer substrate agents (e.g., left-extended and right-extended DsiRNA agents) of the invention is thereby performed.

**[0374]** All patents and publications mentioned in the specification are indicative of the levels of skill of those skilled in the art to which the invention pertains. All references cited in

this disclosure are incorporated by reference to the same extent as if each reference had been incorporated by reference in its entirety individually.

**[0375]** One skilled in the art would readily appreciate that the present invention is well adapted to carry out the objects and obtain the ends and advantages mentioned, as well as those inherent therein. The methods and compositions described herein as presently representative of preferred embodiments are exemplary and are not intended as limitations on the scope of the invention. Changes therein and other uses will occur to those skilled in the art, which are encompassed within the spirit of the invention, are defined by the scope of the claims.

**[0376]** It will be readily apparent to one skilled in the art that varying substitutions and modifications can be made to the invention disclosed herein without departing from the scope and spirit of the invention. Thus, such additional embodiments are within the scope of the present invention and the following claims. The present invention teaches one skilled in the art to test various combinations and/or substitutions of chemical modifications described herein toward generating nucleic acid constructs with improved activity for mediating RNAi activity. Such improved activity can comprise improved stability, improved bioavailability, and/or improved activation of cellular responses mediating RNAi. Therefore, the specific embodiments described herein are not limiting and one skilled in the art can readily appreciate that specific combinations of the modifications described herein can be tested without undue experimentation toward identifying DsiRNA molecules with improved RNAi activity.

**[0377]** The invention illustratively described herein suitably can be practiced in the absence of any element or elements, limitation or limitations that are not specifically disclosed herein. Thus, for example, in each instance herein any of the terms “comprising”, “consisting essentially of”, and “consisting of” may be replaced with either of the other two terms. The terms and expressions which have been employed are used as terms of description and not of limitation, and there is no intention that in the use of such terms and expressions of excluding any equivalents of the features shown and described or portions thereof, but it is recognized that various modifications are possible within the scope of the invention claimed. Thus, it should be understood that although the present invention has been specifically disclosed by preferred embodiments, optional features, modification and variation

of the concepts herein disclosed may be resorted to by those skilled in the art, and that such modifications and variations are considered to be within the scope of this invention as defined by the description and the appended claims.

**[0378]** In addition, where features or aspects of the invention are described in terms of Markush groups or other grouping of alternatives, those skilled in the art will recognize that the invention is also thereby described in terms of any individual member or subgroup of members of the Markush group or other group.

**[0379]** The use of the terms “a” and “an” and “the” and similar referents in the context of describing the invention (especially in the context of the following claims) are to be construed to cover both the singular and the plural, unless otherwise indicated herein or clearly contradicted by context. The terms “comprising,” “having,” “including,” and “containing” are to be construed as open-ended terms (i.e., meaning “including, but not limited to,”) unless otherwise noted. Recitation of ranges of values herein are merely intended to serve as a shorthand method of referring individually to each separate value falling within the range, unless otherwise indicated herein, and each separate value is incorporated into the specification as if it were individually recited herein. All methods described herein can be performed in any suitable order unless otherwise indicated herein or otherwise clearly contradicted by context. The use of any and all examples, or exemplary language (e.g., “such as”) provided herein, is intended merely to better illuminate the invention and does not pose a limitation on the scope of the invention unless otherwise claimed. No language in the specification should be construed as indicating any non-claimed element as essential to the practice of the invention.

Embodiments of this invention are described herein, including the best mode known to the inventors for carrying out the invention. Variations of those embodiments may become apparent to those of ordinary skill in the art upon reading the foregoing description. The inventors expect skilled artisans to employ such variations as appropriate, and the inventors intend for the invention to be practiced otherwise than as specifically described herein. Accordingly, this invention includes all modifications and equivalents of the subject matter recited in the claims appended hereto as permitted by applicable law. Moreover, any combination of the above-described elements in all possible variations thereof is encompassed by the invention unless otherwise indicated herein or otherwise clearly contradicted by context.

---

SEQUENCE LISTING

<160> NUMBER OF SEQ ID NOS: 219

<210> SEQ ID NO 1

<211> LENGTH: 21

<212> TYPE: DNA

<213> ORGANISM: Artificial Sequence

<220> FEATURE:

<223> OTHER INFORMATION: Description of Artificial Sequence: Synthetic primer

<400> SEQUENCE: 1

gactttgctt tccttggtca g

21

<210> SEQ ID NO 2

<211> LENGTH: 24

---

-continued

---

<212> TYPE: DNA  
<213> ORGANISM: Artificial Sequence  
<220> FEATURE:  
<223> OTHER INFORMATION: Description of Artificial Sequence: Synthetic primer  
  
<400> SEQUENCE: 2  
ggcttatatc caacactteg tggg 24

<210> SEQ ID NO 3  
<211> LENGTH: 26  
<212> TYPE: DNA  
<213> ORGANISM: Artificial Sequence  
<220> FEATURE:  
<223> OTHER INFORMATION: Description of Artificial Sequence: Synthetic probe  
  
<400> SEQUENCE: 3  
atggtcaagg tcgcaagctt gctggt 26

<210> SEQ ID NO 4  
<211> LENGTH: 18  
<212> TYPE: DNA  
<213> ORGANISM: Artificial Sequence  
<220> FEATURE:  
<223> OTHER INFORMATION: Description of Artificial Sequence: Synthetic primer  
  
<400> SEQUENCE: 4  
tgtgcagaag gatggagt 18

<210> SEQ ID NO 5  
<211> LENGTH: 20  
<212> TYPE: DNA  
<213> ORGANISM: Artificial Sequence  
<220> FEATURE:  
<223> OTHER INFORMATION: Description of Artificial Sequence: Synthetic primer  
  
<400> SEQUENCE: 5  
ctggtgcttc tetcaggata 20

<210> SEQ ID NO 6  
<211> LENGTH: 25  
<212> TYPE: DNA  
<213> ORGANISM: Artificial Sequence  
<220> FEATURE:  
<223> OTHER INFORMATION: Description of Artificial Sequence: Synthetic probe  
  
<400> SEQUENCE: 6  
tggaatatgc cctgcgtaaa ctgga 25

<210> SEQ ID NO 7  
<211> LENGTH: 20  
<212> TYPE: DNA  
<213> ORGANISM: Artificial Sequence  
<220> FEATURE:  
<223> OTHER INFORMATION: Description of Artificial Sequence: Synthetic primer  
  
<400> SEQUENCE: 7  
caaactttgc tttccctggt 20



---

-continued

---

<210> SEQ ID NO 8  
<211> LENGTH: 21  
<212> TYPE: DNA  
<213> ORGANISM: Artificial Sequence  
<220> FEATURE:  
<223> OTHER INFORMATION: Description of Artificial Sequence: Synthetic primer  
  
<400> SEQUENCE: 8  
  
caacaaagtc tggcctgtat c 21

<210> SEQ ID NO 9  
<211> LENGTH: 26  
<212> TYPE: DNA  
<213> ORGANISM: Artificial Sequence  
<220> FEATURE:  
<223> OTHER INFORMATION: Description of Artificial Sequence: Synthetic probe  
  
<400> SEQUENCE: 9  
  
tggttaaggt tgcaagcttg ctggtg 26

<210> SEQ ID NO 10  
<211> LENGTH: 20  
<212> TYPE: DNA  
<213> ORGANISM: Artificial Sequence  
<220> FEATURE:  
<223> OTHER INFORMATION: Description of Artificial Sequence: Synthetic primer  
  
<400> SEQUENCE: 10  
  
ctttgtggat gactacgacc 20

<210> SEQ ID NO 11  
<211> LENGTH: 20  
<212> TYPE: DNA  
<213> ORGANISM: Artificial Sequence  
<220> FEATURE:  
<223> OTHER INFORMATION: Description of Artificial Sequence: Synthetic primer  
  
<400> SEQUENCE: 11  
  
cactgtactc ctcttgacct 20

<210> SEQ ID NO 12  
<211> LENGTH: 29  
<212> TYPE: DNA  
<213> ORGANISM: Artificial Sequence  
<220> FEATURE:  
<223> OTHER INFORMATION: Description of Artificial Sequence: Synthetic probe  
  
<400> SEQUENCE: 12  
  
acgatagagg actcctacag gaaacaagt 29

<210> SEQ ID NO 13  
<211> LENGTH: 27  
<212> TYPE: DNA  
<213> ORGANISM: Artificial Sequence  
<220> FEATURE:  
<223> OTHER INFORMATION: Description of Artificial Sequence: Synthetic oligonucleotide  
<220> FEATURE:  
<223> OTHER INFORMATION: Description of Combined DNA/RNA Molecule: Synthetic oligonucleotide

---

-continued

---

<400> SEQUENCE: 13

gccagacuuu guuggauuug aaacctt 27

<210> SEQ ID NO 14

<211> LENGTH: 29

<212> TYPE: RNA

<213> ORGANISM: Artificial Sequence

<220> FEATURE:

<223> OTHER INFORMATION: Description of Artificial Sequence: Synthetic  
oligonucleotide

<400> SEQUENCE: 14

aagguuuca aauccaaca agucuggcu 29

<210> SEQ ID NO 15

<211> LENGTH: 21

<212> TYPE: RNA

<213> ORGANISM: Artificial Sequence

<220> FEATURE:

<223> OTHER INFORMATION: Description of Artificial Sequence: Synthetic  
oligonucleotide

<400> SEQUENCE: 15

gccagacuuu guuggauuug a 21

<210> SEQ ID NO 16

<211> LENGTH: 21

<212> TYPE: RNA

<213> ORGANISM: Artificial Sequence

<220> FEATURE:

<223> OTHER INFORMATION: Description of Artificial Sequence: Synthetic  
oligonucleotide

<400> SEQUENCE: 16

aaaaccaaca aagucuggcu u 21

<210> SEQ ID NO 17

<211> LENGTH: 25

<212> TYPE: DNA

<213> ORGANISM: Artificial Sequence

<220> FEATURE:

<223> OTHER INFORMATION: Description of Artificial Sequence: Synthetic  
oligonucleotide

<220> FEATURE:

<223> OTHER INFORMATION: Description of Combined DNA/RNA Molecule:  
Synthetic oligonucleotide

<400> SEQUENCE: 17

gccagacuuu guuggauuug aaatt 25

<210> SEQ ID NO 18

<211> LENGTH: 27

<212> TYPE: RNA

<213> ORGANISM: Artificial Sequence

<220> FEATURE:

<223> OTHER INFORMATION: Description of Artificial Sequence: Synthetic  
oligonucleotide

<400> SEQUENCE: 18

aauucaaa ccaacaaagu cuggcu 27

<210> SEQ ID NO 19

<211> LENGTH: 29

<212> TYPE: RNA

---

-continued

---

<213> ORGANISM: Artificial Sequence  
<220> FEATURE:  
<223> OTHER INFORMATION: Description of Artificial Sequence: Synthetic  
oligonucleotide

<400> SEQUENCE: 19

aagguuucaa auccaacaaa gucuggcuu 29

<210> SEQ ID NO 20  
<211> LENGTH: 31  
<212> TYPE: DNA  
<213> ORGANISM: Artificial Sequence  
<220> FEATURE:  
<223> OTHER INFORMATION: Description of Artificial Sequence: Synthetic  
oligonucleotide

<220> FEATURE:  
<223> OTHER INFORMATION: Description of Combined DNA/RNA Molecule:  
Synthetic oligonucleotide

<400> SEQUENCE: 20

gccagacuuu guuggauug aaaccaacat t 31

<210> SEQ ID NO 21  
<211> LENGTH: 33  
<212> TYPE: RNA  
<213> ORGANISM: Artificial Sequence  
<220> FEATURE:  
<223> OTHER INFORMATION: Description of Artificial Sequence: Synthetic  
oligonucleotide

<400> SEQUENCE: 21

aauguugguu ucaaauccea caaagucugg cuu 33

<210> SEQ ID NO 22  
<211> LENGTH: 27  
<212> TYPE: DNA  
<213> ORGANISM: Artificial Sequence  
<220> FEATURE:  
<223> OTHER INFORMATION: Description of Artificial Sequence: Synthetic  
oligonucleotide

<220> FEATURE:  
<223> OTHER INFORMATION: Description of Combined DNA/RNA Molecule:  
Synthetic oligonucleotide

<400> SEQUENCE: 22

gccagacuuu guuggauug aaacctt 27

<210> SEQ ID NO 23  
<211> LENGTH: 29  
<212> TYPE: DNA  
<213> ORGANISM: Artificial Sequence  
<220> FEATURE:  
<223> OTHER INFORMATION: Description of Artificial Sequence: Synthetic  
oligonucleotide

<220> FEATURE:  
<223> OTHER INFORMATION: Description of Combined DNA/RNA Molecule:  
Synthetic oligonucleotide

<400> SEQUENCE: 23

aagguuucaa auccaacaaa gucuggcuu 29

<210> SEQ ID NO 24  
<211> LENGTH: 31  
<212> TYPE: DNA  
<213> ORGANISM: Artificial Sequence  
<220> FEATURE:

---

-continued

<223> OTHER INFORMATION: Description of Artificial Sequence: Synthetic oligonucleotide  
<220> FEATURE:  
<223> OTHER INFORMATION: Description of Combined DNA/RNA Molecule: Synthetic oligonucleotide  
  
<400> SEQUENCE: 24  
gccagacuuu guuggauuug aaaccaacat t 31  
  
<210> SEQ ID NO 25  
<211> LENGTH: 33  
<212> TYPE: DNA  
<213> ORGANISM: Artificial Sequence  
<220> FEATURE:  
<223> OTHER INFORMATION: Description of Artificial Sequence: Synthetic oligonucleotide  
<220> FEATURE:  
<223> OTHER INFORMATION: Description of Combined DNA/RNA Molecule: Synthetic oligonucleotide  
  
<400> SEQUENCE: 25  
aatggtgguu ucaaauccea caaagucugg cuu 33  
  
<210> SEQ ID NO 26  
<211> LENGTH: 33  
<212> TYPE: DNA  
<213> ORGANISM: Artificial Sequence  
<220> FEATURE:  
<223> OTHER INFORMATION: Description of Artificial Sequence: Synthetic oligonucleotide  
<220> FEATURE:  
<223> OTHER INFORMATION: Description of Combined DNA/RNA Molecule: Synthetic oligonucleotide  
  
<400> SEQUENCE: 26  
gccagacuuu guuggauuug aaaccaacag ctt 33  
  
<210> SEQ ID NO 27  
<211> LENGTH: 35  
<212> TYPE: DNA  
<213> ORGANISM: Artificial Sequence  
<220> FEATURE:  
<223> OTHER INFORMATION: Description of Artificial Sequence: Synthetic oligonucleotide  
<220> FEATURE:  
<223> OTHER INFORMATION: Description of Combined DNA/RNA Molecule: Synthetic oligonucleotide  
  
<400> SEQUENCE: 27  
aagctgttgg uuucaaaucc aacaaagucu ggcuu 35  
  
<210> SEQ ID NO 28  
<211> LENGTH: 33  
<212> TYPE: DNA  
<213> ORGANISM: Artificial Sequence  
<220> FEATURE:  
<223> OTHER INFORMATION: Description of Artificial Sequence: Synthetic oligonucleotide  
<220> FEATURE:  
<223> OTHER INFORMATION: Description of Combined DNA/RNA Molecule: Synthetic oligonucleotide  
  
<400> SEQUENCE: 28  
gccagacuuu guuggauuug aaaccaacag ctt 33  
  
<210> SEQ ID NO 29

---

-continued

---

<211> LENGTH: 35  
<212> TYPE: DNA  
<213> ORGANISM: Artificial Sequence  
<220> FEATURE:  
<223> OTHER INFORMATION: Description of Artificial Sequence: Synthetic oligonucleotide  
  
<400> SEQUENCE: 29  
  
aagcuguugg uuucaaaaucc aacaaagucu ggcuu 35

<210> SEQ ID NO 30  
<211> LENGTH: 25  
<212> TYPE: DNA  
<213> ORGANISM: Artificial Sequence  
<220> FEATURE:  
<223> OTHER INFORMATION: Description of Artificial Sequence: Synthetic oligonucleotide  
<220> FEATURE:  
<223> OTHER INFORMATION: Description of Combined DNA/RNA Molecule: Synthetic oligonucleotide  
  
<400> SEQUENCE: 30  
  
gcuagguugu uucagacuug aaatt 25

<210> SEQ ID NO 31  
<211> LENGTH: 27  
<212> TYPE: RNA  
<213> ORGANISM: Artificial Sequence  
<220> FEATURE:  
<223> OTHER INFORMATION: Description of Artificial Sequence: Synthetic oligonucleotide  
  
<400> SEQUENCE: 31  
  
aauucaagu cugaaacaac cuagcuu 27

<210> SEQ ID NO 32  
<211> LENGTH: 32  
<212> TYPE: DNA  
<213> ORGANISM: Artificial Sequence  
<220> FEATURE:  
<223> OTHER INFORMATION: Description of Artificial Sequence: Synthetic oligonucleotide  
<220> FEATURE:  
<223> OTHER INFORMATION: Description of Combined DNA/RNA Molecule: Synthetic oligonucleotide  
  
<400> SEQUENCE: 32  
  
agccagacuu uguuggauuu gaaaccaaca tt 32

<210> SEQ ID NO 33  
<211> LENGTH: 29  
<212> TYPE: DNA  
<213> ORGANISM: Artificial Sequence  
<220> FEATURE:  
<223> OTHER INFORMATION: Description of Artificial Sequence: Synthetic oligonucleotide  
<220> FEATURE:  
<223> OTHER INFORMATION: Description of Combined DNA/RNA Molecule: Synthetic oligonucleotide  
  
<400> SEQUENCE: 33  
  
gccagacuuu guuggauuug aaaccaatt 29

<210> SEQ ID NO 34  
<211> LENGTH: 31  
<212> TYPE: RNA

---

-continued

---

<213> ORGANISM: Artificial Sequence  
<220> FEATURE:  
<223> OTHER INFORMATION: Description of Artificial Sequence: Synthetic  
oligonucleotide

<400> SEQUENCE: 34

aauggguuuc aaauccaaca aagucuggcu u 31

<210> SEQ ID NO 35  
<211> LENGTH: 33  
<212> TYPE: DNA  
<213> ORGANISM: Artificial Sequence  
<220> FEATURE:  
<223> OTHER INFORMATION: Description of Artificial Sequence: Synthetic  
oligonucleotide  
<220> FEATURE:  
<223> OTHER INFORMATION: Description of Combined DNA/RNA Molecule:  
Synthetic oligonucleotide

<400> SEQUENCE: 35

gccagacuuu guuggauuug aaaccaacag ctt 33

<210> SEQ ID NO 36  
<211> LENGTH: 29  
<212> TYPE: DNA  
<213> ORGANISM: Artificial Sequence  
<220> FEATURE:  
<223> OTHER INFORMATION: Description of Artificial Sequence: Synthetic  
oligonucleotide  
<220> FEATURE:  
<223> OTHER INFORMATION: Description of Combined DNA/RNA Molecule:  
Synthetic oligonucleotide

<400> SEQUENCE: 36

gccagacuuu guuggauuug aaaccaatt 29

<210> SEQ ID NO 37  
<211> LENGTH: 31  
<212> TYPE: DNA  
<213> ORGANISM: Artificial Sequence  
<220> FEATURE:  
<223> OTHER INFORMATION: Description of Artificial Sequence: Synthetic  
oligonucleotide  
<220> FEATURE:  
<223> OTHER INFORMATION: Description of Combined DNA/RNA Molecule:  
Synthetic oligonucleotide

<400> SEQUENCE: 37

aattgguuuc aaauccaaca aagucuggcu u 31

<210> SEQ ID NO 38  
<211> LENGTH: 25  
<212> TYPE: DNA  
<213> ORGANISM: Artificial Sequence  
<220> FEATURE:  
<223> OTHER INFORMATION: Description of Artificial Sequence: Synthetic  
oligonucleotide  
<220> FEATURE:  
<223> OTHER INFORMATION: Description of Combined DNA/RNA Molecule:  
Synthetic oligonucleotide

<400> SEQUENCE: 38

ggaggguuuu cuuuguguau uggcc 25

<210> SEQ ID NO 39  
<211> LENGTH: 27

---

-continued

---

<212> TYPE: RNA  
<213> ORGANISM: Artificial Sequence  
<220> FEATURE:  
<223> OTHER INFORMATION: Description of Artificial Sequence: Synthetic  
oligonucleotide

<400> SEQUENCE: 39

ggcaaaauaca caaagaaagc ccucuccc 27

<210> SEQ ID NO 40  
<211> LENGTH: 30  
<212> TYPE: DNA  
<213> ORGANISM: Artificial Sequence  
<220> FEATURE:  
<223> OTHER INFORMATION: Description of Artificial Sequence: Synthetic  
oligonucleotide  
<220> FEATURE:  
<223> OTHER INFORMATION: Description of Combined DNA/RNA Molecule:  
Synthetic oligonucleotide

<400> SEQUENCE: 40

ggaccuuggg gagggcuuuc uuuguguacc 30

<210> SEQ ID NO 41  
<211> LENGTH: 28  
<212> TYPE: DNA  
<213> ORGANISM: Artificial Sequence  
<220> FEATURE:  
<223> OTHER INFORMATION: Description of Artificial Sequence: Synthetic  
oligonucleotide  
<220> FEATURE:  
<223> OTHER INFORMATION: Description of Combined DNA/RNA Molecule:  
Synthetic oligonucleotide

<400> SEQUENCE: 41

uacacaaaga aaguccuccc caaggtcc 28

<210> SEQ ID NO 42  
<211> LENGTH: 28  
<212> TYPE: DNA  
<213> ORGANISM: Artificial Sequence  
<220> FEATURE:  
<223> OTHER INFORMATION: Description of Artificial Sequence: Synthetic  
oligonucleotide  
<220> FEATURE:  
<223> OTHER INFORMATION: Description of Combined DNA/RNA Molecule:  
Synthetic oligonucleotide

<400> SEQUENCE: 42

ggagggcuuu cuuguguac caaggtcc 28

<210> SEQ ID NO 43  
<211> LENGTH: 30  
<212> TYPE: DNA  
<213> ORGANISM: Artificial Sequence  
<220> FEATURE:  
<223> OTHER INFORMATION: Description of Artificial Sequence: Synthetic  
oligonucleotide  
<220> FEATURE:  
<223> OTHER INFORMATION: Description of Combined DNA/RNA Molecule:  
Synthetic oligonucleotide

<400> SEQUENCE: 43

ggaccuuggu acacaaagaa agccuccccc 30

<210> SEQ ID NO 44

---

-continued

<211> LENGTH: 28  
<212> TYPE: DNA  
<213> ORGANISM: Artificial Sequence  
<220> FEATURE:  
<223> OTHER INFORMATION: Description of Artificial Sequence: Synthetic oligonucleotide  
<220> FEATURE:  
<223> OTHER INFORMATION: Description of Combined DNA/RNA Molecule: Synthetic oligonucleotide  
  
<400> SEQUENCE: 44  
  
uacacaaaga aagccuccc caaggtcc 28  
  
<210> SEQ ID NO 45  
<211> LENGTH: 30  
<212> TYPE: DNA  
<213> ORGANISM: Artificial Sequence  
<220> FEATURE:  
<223> OTHER INFORMATION: Description of Artificial Sequence: Synthetic oligonucleotide  
<220> FEATURE:  
<223> OTHER INFORMATION: Description of Combined DNA/RNA Molecule: Synthetic oligonucleotide  
  
<400> SEQUENCE: 45  
  
ggaccuuggu acacaaagaa ggccucccc 30  
  
<210> SEQ ID NO 46  
<211> LENGTH: 28  
<212> TYPE: DNA  
<213> ORGANISM: Artificial Sequence  
<220> FEATURE:  
<223> OTHER INFORMATION: Description of Artificial Sequence: Synthetic oligonucleotide  
<220> FEATURE:  
<223> OTHER INFORMATION: Description of Combined DNA/RNA Molecule: Synthetic oligonucleotide  
  
<400> SEQUENCE: 46  
  
uacacaaaga aggccuccc caaggtcc 28  
  
<210> SEQ ID NO 47  
<211> LENGTH: 30  
<212> TYPE: DNA  
<213> ORGANISM: Artificial Sequence  
<220> FEATURE:  
<223> OTHER INFORMATION: Description of Artificial Sequence: Synthetic oligonucleotide  
<220> FEATURE:  
<223> OTHER INFORMATION: Description of Combined DNA/RNA Molecule: Synthetic oligonucleotide  
  
<400> SEQUENCE: 47  
  
ggaccuuggu acacaaagaa aguccuccc 30  
  
<210> SEQ ID NO 48  
<211> LENGTH: 30  
<212> TYPE: DNA  
<213> ORGANISM: Artificial Sequence  
<220> FEATURE:  
<223> OTHER INFORMATION: Description of Artificial Sequence: Synthetic oligonucleotide  
<220> FEATURE:  
<223> OTHER INFORMATION: Description of Combined DNA/RNA Molecule: Synthetic oligonucleotide  
  
<400> SEQUENCE: 48



---

-continued

---

ggaccuuggu acacaaagaa agccuucucc 30

<210> SEQ ID NO 49  
<211> LENGTH: 28  
<212> TYPE: DNA  
<213> ORGANISM: Artificial Sequence  
<220> FEATURE:  
<223> OTHER INFORMATION: Description of Artificial Sequence: Synthetic  
oligonucleotide  
<220> FEATURE:  
<223> OTHER INFORMATION: Description of Combined DNA/RNA Molecule:  
Synthetic oligonucleotide  
  
<400> SEQUENCE: 49

uacacaaaga aagccuucucc caaggtcc 28

<210> SEQ ID NO 50  
<211> LENGTH: 30  
<212> TYPE: DNA  
<213> ORGANISM: Artificial Sequence  
<220> FEATURE:  
<223> OTHER INFORMATION: Description of Artificial Sequence: Synthetic  
oligonucleotide  
<220> FEATURE:  
<223> OTHER INFORMATION: Description of Combined DNA/RNA Molecule:  
Synthetic oligonucleotide  
  
<400> SEQUENCE: 50

ggaccuuggu acacaaagaa aguccuucucc 30

<210> SEQ ID NO 51  
<211> LENGTH: 28  
<212> TYPE: DNA  
<213> ORGANISM: Artificial Sequence  
<220> FEATURE:  
<223> OTHER INFORMATION: Description of Artificial Sequence: Synthetic  
oligonucleotide  
<220> FEATURE:  
<223> OTHER INFORMATION: Description of Combined DNA/RNA Molecule:  
Synthetic oligonucleotide  
  
<400> SEQUENCE: 51

uacacaaaga aaguccuucc caaggtcc 28

<210> SEQ ID NO 52  
<211> LENGTH: 30  
<212> TYPE: DNA  
<213> ORGANISM: Artificial Sequence  
<220> FEATURE:  
<223> OTHER INFORMATION: Description of Artificial Sequence: Synthetic  
oligonucleotide  
<220> FEATURE:  
<223> OTHER INFORMATION: Description of Combined DNA/RNA Molecule:  
Synthetic oligonucleotide  
  
<400> SEQUENCE: 52

ggaccuuggu acacaaagaa ggccuucucc 30

<210> SEQ ID NO 53  
<211> LENGTH: 28  
<212> TYPE: DNA  
<213> ORGANISM: Artificial Sequence  
<220> FEATURE:  
<223> OTHER INFORMATION: Description of Artificial Sequence: Synthetic  
oligonucleotide  
<220> FEATURE:  
<223> OTHER INFORMATION: Description of Combined DNA/RNA Molecule:

---

-continued

---

Synthetic oligonucleotide

<400> SEQUENCE: 53

uacacaaaga aggccuuccc caaggctc 28

<210> SEQ ID NO 54  
<211> LENGTH: 25  
<212> TYPE: DNA  
<213> ORGANISM: Artificial Sequence  
<220> FEATURE:  
<223> OTHER INFORMATION: Description of Artificial Sequence: Synthetic oligonucleotide  
<220> FEATURE:  
<223> OTHER INFORMATION: Description of Combined DNA/RNA Molecule: Synthetic oligonucleotide

<400> SEQUENCE: 54

gccagacuuu guuggauuug aaatt 25

<210> SEQ ID NO 55  
<211> LENGTH: 27  
<212> TYPE: DNA  
<213> ORGANISM: Artificial Sequence  
<220> FEATURE:  
<223> OTHER INFORMATION: Description of Artificial Sequence: Synthetic oligonucleotide  
<220> FEATURE:  
<223> OTHER INFORMATION: Description of Combined DNA/RNA Molecule: Synthetic oligonucleotide

<400> SEQUENCE: 55

aattucaaa ccaacaaagu cuggcuu 27

<210> SEQ ID NO 56  
<211> LENGTH: 27  
<212> TYPE: DNA  
<213> ORGANISM: Artificial Sequence  
<220> FEATURE:  
<223> OTHER INFORMATION: Description of Artificial Sequence: Synthetic oligonucleotide  
<220> FEATURE:  
<223> OTHER INFORMATION: Description of Combined DNA/RNA Molecule: Synthetic oligonucleotide

<400> SEQUENCE: 56

aatttcaau ccaacaaagu cuggcuu 27

<210> SEQ ID NO 57  
<211> LENGTH: 27  
<212> TYPE: DNA  
<213> ORGANISM: Artificial Sequence  
<220> FEATURE:  
<223> OTHER INFORMATION: Description of Artificial Sequence: Synthetic oligonucleotide  
<220> FEATURE:  
<223> OTHER INFORMATION: Description of Combined DNA/RNA Molecule: Synthetic oligonucleotide

<400> SEQUENCE: 57

gccagacuuu guuggauuug aaacctt 27

<210> SEQ ID NO 58  
<211> LENGTH: 29  
<212> TYPE: DNA  
<213> ORGANISM: Artificial Sequence  
<220> FEATURE:

---

-continued

<223> OTHER INFORMATION: Description of Artificial Sequence: Synthetic oligonucleotide  
<220> FEATURE:  
<223> OTHER INFORMATION: Description of Combined DNA/RNA Molecule: Synthetic oligonucleotide  
  
<400> SEQUENCE: 58  
aaggttucaa auccaacaaa gucuggcuu 29  
  
<210> SEQ ID NO 59  
<211> LENGTH: 29  
<212> TYPE: DNA  
<213> ORGANISM: Artificial Sequence  
<220> FEATURE:  
<223> OTHER INFORMATION: Description of Artificial Sequence: Synthetic oligonucleotide  
<220> FEATURE:  
<223> OTHER INFORMATION: Description of Combined DNA/RNA Molecule: Synthetic oligonucleotide  
  
<400> SEQUENCE: 59  
aaggtttcaa auccaacaaa gucuggcuu 29  
  
<210> SEQ ID NO 60  
<211> LENGTH: 33  
<212> TYPE: DNA  
<213> ORGANISM: Artificial Sequence  
<220> FEATURE:  
<223> OTHER INFORMATION: Description of Artificial Sequence: Synthetic oligonucleotide  
<220> FEATURE:  
<223> OTHER INFORMATION: Description of Combined DNA/RNA Molecule: Synthetic oligonucleotide  
  
<400> SEQUENCE: 60  
aggcaggtuu aagccagacu uguuggauu uga 33  
  
<210> SEQ ID NO 61  
<211> LENGTH: 31  
<212> TYPE: DNA  
<213> ORGANISM: Artificial Sequence  
<220> FEATURE:  
<223> OTHER INFORMATION: Description of Artificial Sequence: Synthetic oligonucleotide  
<220> FEATURE:  
<223> OTHER INFORMATION: Description of Combined DNA/RNA Molecule: Synthetic oligonucleotide  
  
<400> SEQUENCE: 61  
aaaaccaaca aagucuggcu uaaacctgcc t 31  
  
<210> SEQ ID NO 62  
<211> LENGTH: 31  
<212> TYPE: DNA  
<213> ORGANISM: Artificial Sequence  
<220> FEATURE:  
<223> OTHER INFORMATION: Description of Artificial Sequence: Synthetic oligonucleotide  
<220> FEATURE:  
<223> OTHER INFORMATION: Description of Combined DNA/RNA Molecule: Synthetic oligonucleotide  
  
<400> SEQUENCE: 62  
aaaaucaaca aagucuggcu uaaacctgcc t 31  
  
<210> SEQ ID NO 63

---

-continued

---

<211> LENGTH: 25  
<212> TYPE: DNA  
<213> ORGANISM: Artificial Sequence  
<220> FEATURE:  
<223> OTHER INFORMATION: Description of Artificial Sequence: Synthetic oligonucleotide  
<220> FEATURE:  
<223> OTHER INFORMATION: Description of Combined DNA/RNA Molecule: Synthetic oligonucleotide  
  
<400> SEQUENCE: 63  
  
caggucaaga ggaguacagu gcaat 25  
  
<210> SEQ ID NO 64  
<211> LENGTH: 27  
<212> TYPE: RNA  
<213> ORGANISM: Artificial Sequence  
<220> FEATURE:  
<223> OTHER INFORMATION: Description of Artificial Sequence: Synthetic oligonucleotide  
  
<400> SEQUENCE: 64  
  
auugcacugu acuccucuug accugcu 27  
  
<210> SEQ ID NO 65  
<211> LENGTH: 25  
<212> TYPE: DNA  
<213> ORGANISM: Artificial Sequence  
<220> FEATURE:  
<223> OTHER INFORMATION: Description of Artificial Sequence: Synthetic oligonucleotide  
<220> FEATURE:  
<223> OTHER INFORMATION: Description of Combined DNA/RNA Molecule: Synthetic oligonucleotide  
  
<400> SEQUENCE: 65  
  
caggucaaga ggaguacagu gcaat 25  
  
<210> SEQ ID NO 66  
<211> LENGTH: 27  
<212> TYPE: DNA  
<213> ORGANISM: Artificial Sequence  
<220> FEATURE:  
<223> OTHER INFORMATION: Description of Artificial Sequence: Synthetic oligonucleotide  
<220> FEATURE:  
<223> OTHER INFORMATION: Description of Combined DNA/RNA Molecule: Synthetic oligonucleotide  
  
<400> SEQUENCE: 66  
  
attgcacugu acuccucuug accugcu 27  
  
<210> SEQ ID NO 67  
<211> LENGTH: 30  
<212> TYPE: DNA  
<213> ORGANISM: Artificial Sequence  
<220> FEATURE:  
<223> OTHER INFORMATION: Description of Artificial Sequence: Synthetic oligonucleotide  
<220> FEATURE:  
<223> OTHER INFORMATION: Description of Combined DNA/RNA Molecule: Synthetic oligonucleotide  
  
<400> SEQUENCE: 67  
  
caggucaaga ggaguacagu gcagauacat 30

---

-continued

---

<210> SEQ ID NO 68  
<211> LENGTH: 32  
<212> TYPE: RNA  
<213> ORGANISM: Artificial Sequence  
<220> FEATURE:  
<223> OTHER INFORMATION: Description of Artificial Sequence: Synthetic  
oligonucleotide  
  
<400> SEQUENCE: 68  
  
auguaucugc acuguacucc ucuugaccug cu 32

<210> SEQ ID NO 69  
<211> LENGTH: 30  
<212> TYPE: DNA  
<213> ORGANISM: Artificial Sequence  
<220> FEATURE:  
<223> OTHER INFORMATION: Description of Artificial Sequence: Synthetic  
oligonucleotide  
<220> FEATURE:  
<223> OTHER INFORMATION: Description of Combined DNA/RNA Molecule:  
Synthetic oligonucleotide  
  
<400> SEQUENCE: 69  
  
caggucaaga ggaguacagu gcagatacat 30

<210> SEQ ID NO 70  
<211> LENGTH: 32  
<212> TYPE: DNA  
<213> ORGANISM: Artificial Sequence  
<220> FEATURE:  
<223> OTHER INFORMATION: Description of Artificial Sequence: Synthetic  
oligonucleotide  
<220> FEATURE:  
<223> OTHER INFORMATION: Description of Combined DNA/RNA Molecule:  
Synthetic oligonucleotide  
  
<400> SEQUENCE: 70  
  
atgtatctgc acuguacucc ucuugaccug cu 32

<210> SEQ ID NO 71  
<211> LENGTH: 35  
<212> TYPE: DNA  
<213> ORGANISM: Artificial Sequence  
<220> FEATURE:  
<223> OTHER INFORMATION: Description of Artificial Sequence: Synthetic  
oligonucleotide  
<220> FEATURE:  
<223> OTHER INFORMATION: Description of Combined DNA/RNA Molecule:  
Synthetic oligonucleotide  
  
<400> SEQUENCE: 71  
  
caggucaaga ggaguacagu gcacaugga uacat 35

<210> SEQ ID NO 72  
<211> LENGTH: 37  
<212> TYPE: RNA  
<213> ORGANISM: Artificial Sequence  
<220> FEATURE:  
<223> OTHER INFORMATION: Description of Artificial Sequence: Synthetic  
oligonucleotide  
  
<400> SEQUENCE: 72  
  
auguauccau ugugcacugu acuccucug accugcu 37

<210> SEQ ID NO 73  
<211> LENGTH: 35

---

-continued

<212> TYPE: DNA  
<213> ORGANISM: Artificial Sequence  
<220> FEATURE:  
<223> OTHER INFORMATION: Description of Artificial Sequence: Synthetic  
oligonucleotide  
<220> FEATURE:  
<223> OTHER INFORMATION: Description of Combined DNA/RNA Molecule:  
Synthetic oligonucleotide  
  
<400> SEQUENCE: 73  
caggucaaga ggaguacagu gcacaatgga tacat 35  
  
<210> SEQ ID NO 74  
<211> LENGTH: 37  
<212> TYPE: DNA  
<213> ORGANISM: Artificial Sequence  
<220> FEATURE:  
<223> OTHER INFORMATION: Description of Artificial Sequence: Synthetic  
oligonucleotide  
<220> FEATURE:  
<223> OTHER INFORMATION: Description of Combined DNA/RNA Molecule:  
Synthetic oligonucleotide  
  
<400> SEQUENCE: 74  
atgtatccat tgtgcacugu acuccucuug accugcu 37  
  
<210> SEQ ID NO 75  
<211> LENGTH: 25  
<212> TYPE: DNA  
<213> ORGANISM: Artificial Sequence  
<220> FEATURE:  
<223> OTHER INFORMATION: Description of Artificial Sequence: Synthetic  
oligonucleotide  
<220> FEATURE:  
<223> OTHER INFORMATION: Description of Combined DNA/RNA Molecule:  
Synthetic oligonucleotide  
  
<400> SEQUENCE: 75  
ggugugaaac aaaauaauga agctt 25  
  
<210> SEQ ID NO 76  
<211> LENGTH: 27  
<212> TYPE: RNA  
<213> ORGANISM: Artificial Sequence  
<220> FEATURE:  
<223> OTHER INFORMATION: Description of Artificial Sequence: Synthetic  
oligonucleotide  
  
<400> SEQUENCE: 76  
aagcuucauu aauuuguuuc acaccaa 27  
  
<210> SEQ ID NO 77  
<211> LENGTH: 25  
<212> TYPE: DNA  
<213> ORGANISM: Artificial Sequence  
<220> FEATURE:  
<223> OTHER INFORMATION: Description of Artificial Sequence: Synthetic  
oligonucleotide  
<220> FEATURE:  
<223> OTHER INFORMATION: Description of Combined DNA/RNA Molecule:  
Synthetic oligonucleotide  
  
<400> SEQUENCE: 77  
ggugugaaac aaaauaauga agctt 25  
  
<210> SEQ ID NO 78

---

-continued

---

<211> LENGTH: 27  
<212> TYPE: DNA  
<213> ORGANISM: Artificial Sequence  
<220> FEATURE:  
<223> OTHER INFORMATION: Description of Artificial Sequence: Synthetic oligonucleotide  
<220> FEATURE:  
<223> OTHER INFORMATION: Description of Combined DNA/RNA Molecule: Synthetic oligonucleotide  
  
<400> SEQUENCE: 78  
  
aagcttcauu aauuuguuuc acaccaa 27  
  
<210> SEQ ID NO 79  
<211> LENGTH: 30  
<212> TYPE: DNA  
<213> ORGANISM: Artificial Sequence  
<220> FEATURE:  
<223> OTHER INFORMATION: Description of Artificial Sequence: Synthetic oligonucleotide  
<220> FEATURE:  
<223> OTHER INFORMATION: Description of Combined DNA/RNA Molecule: Synthetic oligonucleotide  
  
<400> SEQUENCE: 79  
  
ggugugaaac aaauuaauga agcgauactt 30  
  
<210> SEQ ID NO 80  
<211> LENGTH: 32  
<212> TYPE: RNA  
<213> ORGANISM: Artificial Sequence  
<220> FEATURE:  
<223> OTHER INFORMATION: Description of Artificial Sequence: Synthetic oligonucleotide  
  
<400> SEQUENCE: 80  
  
aaguaucgcu ucauuuuuu guuucacacc aa 32  
  
<210> SEQ ID NO 81  
<211> LENGTH: 30  
<212> TYPE: DNA  
<213> ORGANISM: Artificial Sequence  
<220> FEATURE:  
<223> OTHER INFORMATION: Description of Artificial Sequence: Synthetic oligonucleotide  
<220> FEATURE:  
<223> OTHER INFORMATION: Description of Combined DNA/RNA Molecule: Synthetic oligonucleotide  
  
<400> SEQUENCE: 81  
  
ggugugaaac aaauuauga agcgatactt 30  
  
<210> SEQ ID NO 82  
<211> LENGTH: 32  
<212> TYPE: DNA  
<213> ORGANISM: Artificial Sequence  
<220> FEATURE:  
<223> OTHER INFORMATION: Description of Artificial Sequence: Synthetic oligonucleotide  
<220> FEATURE:  
<223> OTHER INFORMATION: Description of Combined DNA/RNA Molecule: Synthetic oligonucleotide  
  
<400> SEQUENCE: 82  
  
aagtatcgct tcauuuuuu guuucacacc aa 32

---

-continued

<210> SEQ ID NO 83  
<211> LENGTH: 35  
<212> TYPE: DNA  
<213> ORGANISM: Artificial Sequence  
<220> FEATURE:  
<223> OTHER INFORMATION: Description of Artificial Sequence: Synthetic  
oligonucleotide  
<220> FEATURE:  
<223> OTHER INFORMATION: Description of Combined DNA/RNA Molecule:  
Synthetic oligonucleotide  
  
<400> SEQUENCE: 83  
  
ggugugaaac aaauaauga agccaugga uactt 35

<210> SEQ ID NO 84  
<211> LENGTH: 37  
<212> TYPE: RNA  
<213> ORGANISM: Artificial Sequence  
<220> FEATURE:  
<223> OTHER INFORMATION: Description of Artificial Sequence: Synthetic  
oligonucleotide  
  
<400> SEQUENCE: 84  
  
aaguauccau uggcucauu aauuuguuuc acaccaa 37

<210> SEQ ID NO 85  
<211> LENGTH: 35  
<212> TYPE: DNA  
<213> ORGANISM: Artificial Sequence  
<220> FEATURE:  
<223> OTHER INFORMATION: Description of Artificial Sequence: Synthetic  
oligonucleotide  
<220> FEATURE:  
<223> OTHER INFORMATION: Description of Combined DNA/RNA Molecule:  
Synthetic oligonucleotide  
  
<400> SEQUENCE: 85  
  
ggugugaaac aaauaauga agccaatgga tactt 35

<210> SEQ ID NO 86  
<211> LENGTH: 37  
<212> TYPE: DNA  
<213> ORGANISM: Artificial Sequence  
<220> FEATURE:  
<223> OTHER INFORMATION: Description of Artificial Sequence: Synthetic  
oligonucleotide  
<220> FEATURE:  
<223> OTHER INFORMATION: Description of Combined DNA/RNA Molecule:  
Synthetic oligonucleotide  
  
<400> SEQUENCE: 86  
  
aagtatccat tggcttcauu aauuuguuuc acaccaa 37

<210> SEQ ID NO 87  
<211> LENGTH: 12  
<212> TYPE: DNA  
<213> ORGANISM: Artificial Sequence  
<220> FEATURE:  
<223> OTHER INFORMATION: Description of Artificial Sequence: Synthetic  
oligonucleotide  
<220> FEATURE:  
<223> OTHER INFORMATION: Description of Combined DNA/RNA Molecule:  
Synthetic oligonucleotide  
  
<400> SEQUENCE: 87  
  
gaagcgauac tt 12



---

-continued

---

<210> SEQ ID NO 88  
<211> LENGTH: 12  
<212> TYPE: RNA  
<213> ORGANISM: Artificial Sequence  
<220> FEATURE:  
<223> OTHER INFORMATION: Description of Artificial Sequence: Synthetic  
oligonucleotide

<400> SEQUENCE: 88

aaguaucgcu uc 12

<210> SEQ ID NO 89  
<211> LENGTH: 12  
<212> TYPE: DNA  
<213> ORGANISM: Artificial Sequence  
<220> FEATURE:  
<223> OTHER INFORMATION: Description of Artificial Sequence: Synthetic  
oligonucleotide  
<220> FEATURE:  
<223> OTHER INFORMATION: Description of Combined DNA/RNA Molecule:  
Synthetic oligonucleotide

<400> SEQUENCE: 89

gaagcgatac tt 12

<210> SEQ ID NO 90  
<211> LENGTH: 12  
<212> TYPE: DNA  
<213> ORGANISM: Artificial Sequence  
<220> FEATURE:  
<223> OTHER INFORMATION: Description of Artificial Sequence: Synthetic  
oligonucleotide  
<220> FEATURE:  
<223> OTHER INFORMATION: Description of Combined DNA/RNA Molecule:  
Synthetic oligonucleotide

<400> SEQUENCE: 90

aagtatcgct tc 12

<210> SEQ ID NO 91  
<211> LENGTH: 17  
<212> TYPE: DNA  
<213> ORGANISM: Artificial Sequence  
<220> FEATURE:  
<223> OTHER INFORMATION: Description of Artificial Sequence: Synthetic  
oligonucleotide  
<220> FEATURE:  
<223> OTHER INFORMATION: Description of Combined DNA/RNA Molecule:  
Synthetic oligonucleotide

<400> SEQUENCE: 91

gaagccaau g auactt 17

<210> SEQ ID NO 92  
<211> LENGTH: 17  
<212> TYPE: DNA  
<213> ORGANISM: Artificial Sequence  
<220> FEATURE:  
<223> OTHER INFORMATION: Description of Artificial Sequence: Synthetic  
oligonucleotide

<400> SEQUENCE: 92

aaguauccau uggcuuc 17

<210> SEQ ID NO 93

---

-continued

---

<211> LENGTH: 17  
<212> TYPE: DNA  
<213> ORGANISM: Artificial Sequence  
<220> FEATURE:  
<223> OTHER INFORMATION: Description of Artificial Sequence: Synthetic oligonucleotide  
<220> FEATURE:  
<223> OTHER INFORMATION: Description of Combined DNA/RNA Molecule: Synthetic oligonucleotide  
  
<400> SEQUENCE: 93  
  
gaagccaatg gatactt 17  
  
<210> SEQ ID NO 94  
<211> LENGTH: 17  
<212> TYPE: DNA  
<213> ORGANISM: Artificial Sequence  
<220> FEATURE:  
<223> OTHER INFORMATION: Description of Artificial Sequence: Synthetic oligonucleotide  
<220> FEATURE:  
<223> OTHER INFORMATION: Description of Combined DNA/RNA Molecule: Synthetic oligonucleotide  
  
<400> SEQUENCE: 94  
  
aagtatccat tggcttc 17  
  
<210> SEQ ID NO 95  
<211> LENGTH: 31  
<212> TYPE: DNA  
<213> ORGANISM: Artificial Sequence  
<220> FEATURE:  
<223> OTHER INFORMATION: Description of Artificial Sequence: Synthetic oligonucleotide  
<220> FEATURE:  
<223> OTHER INFORMATION: Description of Combined DNA/RNA Molecule: Synthetic oligonucleotide  
  
<400> SEQUENCE: 95  
  
ggagggcuuu cuuuguguau uugccaacct t 31  
  
<210> SEQ ID NO 96  
<211> LENGTH: 33  
<212> TYPE: DNA  
<213> ORGANISM: Artificial Sequence  
<220> FEATURE:  
<223> OTHER INFORMATION: Description of Artificial Sequence: Synthetic oligonucleotide  
<220> FEATURE:  
<223> OTHER INFORMATION: Description of Combined DNA/RNA Molecule: Synthetic oligonucleotide  
  
<400> SEQUENCE: 96  
  
aaggttggca aauacacaaa gaaagcccuc ccc 33  
  
<210> SEQ ID NO 97  
<211> LENGTH: 33  
<212> TYPE: DNA  
<213> ORGANISM: Artificial Sequence  
<220> FEATURE:  
<223> OTHER INFORMATION: Description of Artificial Sequence: Synthetic oligonucleotide  
<220> FEATURE:  
<223> OTHER INFORMATION: Description of Combined DNA/RNA Molecule: Synthetic oligonucleotide  
  
<400> SEQUENCE: 97

---

-continued

---

ggagggcuuu cuuuguguau utgccaacct tgg 33

<210> SEQ ID NO 98  
<211> LENGTH: 35  
<212> TYPE: DNA  
<213> ORGANISM: Artificial Sequence  
<220> FEATURE:  
<223> OTHER INFORMATION: Description of Artificial Sequence: Synthetic  
oligonucleotide  
<220> FEATURE:  
<223> OTHER INFORMATION: Description of Combined DNA/RNA Molecule:  
Synthetic oligonucleotide  
  
<400> SEQUENCE: 98

ccaaggttgg caauacaca aagaaagccc ucccc 35

<210> SEQ ID NO 99  
<211> LENGTH: 37  
<212> TYPE: DNA  
<213> ORGANISM: Artificial Sequence  
<220> FEATURE:  
<223> OTHER INFORMATION: Description of Artificial Sequence: Synthetic  
oligonucleotide  
<220> FEATURE:  
<223> OTHER INFORMATION: Description of Combined DNA/RNA Molecule:  
Synthetic oligonucleotide  
  
<400> SEQUENCE: 99

ggagggcuuu cuuuguguau utgccaacct tggaacc 37

<210> SEQ ID NO 100  
<211> LENGTH: 39  
<212> TYPE: DNA  
<213> ORGANISM: Artificial Sequence  
<220> FEATURE:  
<223> OTHER INFORMATION: Description of Artificial Sequence: Synthetic  
oligonucleotide  
<220> FEATURE:  
<223> OTHER INFORMATION: Description of Combined DNA/RNA Molecule:  
Synthetic oligonucleotide  
  
<400> SEQUENCE: 100

ggttccaagg ttggcaaaua cacaagaaa gccuccccc 39

<210> SEQ ID NO 101  
<211> LENGTH: 33  
<212> TYPE: DNA  
<213> ORGANISM: Artificial Sequence  
<220> FEATURE:  
<223> OTHER INFORMATION: Description of Artificial Sequence: Synthetic  
oligonucleotide  
<220> FEATURE:  
<223> OTHER INFORMATION: Description of Combined DNA/RNA Molecule:  
Synthetic oligonucleotide  
  
<400> SEQUENCE: 101

aaaacauaaa gaaaagauga gtgccaacct tgg 33

<210> SEQ ID NO 102  
<211> LENGTH: 35  
<212> TYPE: DNA  
<213> ORGANISM: Artificial Sequence  
<220> FEATURE:  
<223> OTHER INFORMATION: Description of Artificial Sequence: Synthetic  
oligonucleotide  
<220> FEATURE:  
<223> OTHER INFORMATION: Description of Combined DNA/RNA Molecule:

-continued

---

Synthetic oligonucleotide

<400> SEQUENCE: 102

ccaaggttgg cactcaucuu uucuuuaugu uuucg 35

<210> SEQ ID NO 103  
<211> LENGTH: 37  
<212> TYPE: DNA  
<213> ORGANISM: Artificial Sequence  
<220> FEATURE:  
<223> OTHER INFORMATION: Description of Artificial Sequence: Synthetic oligonucleotide  
<220> FEATURE:  
<223> OTHER INFORMATION: Description of Combined DNA/RNA Molecule: Synthetic oligonucleotide

<400> SEQUENCE: 103

aaaacauaaa gaaaagauga gtgccaacct tggaacc 37

<210> SEQ ID NO 104  
<211> LENGTH: 39  
<212> TYPE: DNA  
<213> ORGANISM: Artificial Sequence  
<220> FEATURE:  
<223> OTHER INFORMATION: Description of Artificial Sequence: Synthetic oligonucleotide  
<220> FEATURE:  
<223> OTHER INFORMATION: Description of Combined DNA/RNA Molecule: Synthetic oligonucleotide

<400> SEQUENCE: 104

ggttccaagg ttggcactca uuuuuuuuu auguuuuucg 39

<210> SEQ ID NO 105  
<211> LENGTH: 33  
<212> TYPE: DNA  
<213> ORGANISM: Artificial Sequence  
<220> FEATURE:  
<223> OTHER INFORMATION: Description of Artificial Sequence: Synthetic oligonucleotide  
<220> FEATURE:  
<223> OTHER INFORMATION: Description of Combined DNA/RNA Molecule: Synthetic oligonucleotide

<400> SEQUENCE: 105

ggugugaaac aaauuauga atgccaacct tgg 33

<210> SEQ ID NO 106  
<211> LENGTH: 35  
<212> TYPE: DNA  
<213> ORGANISM: Artificial Sequence  
<220> FEATURE:  
<223> OTHER INFORMATION: Description of Artificial Sequence: Synthetic oligonucleotide  
<220> FEATURE:  
<223> OTHER INFORMATION: Description of Combined DNA/RNA Molecule: Synthetic oligonucleotide

<400> SEQUENCE: 106

ccaaggttgg cattcauuaa uuuguuucac accaa 35

<210> SEQ ID NO 107  
<211> LENGTH: 37  
<212> TYPE: DNA  
<213> ORGANISM: Artificial Sequence  
<220> FEATURE:

---

-continued

<223> OTHER INFORMATION: Description of Artificial Sequence: Synthetic oligonucleotide  
<220> FEATURE:  
<223> OTHER INFORMATION: Description of Combined DNA/RNA Molecule: Synthetic oligonucleotide  
  
<400> SEQUENCE: 107  
ggugugaaac aaauaauga atgccaacct tggaacc 37  
  
<210> SEQ ID NO 108  
<211> LENGTH: 39  
<212> TYPE: DNA  
<213> ORGANISM: Artificial Sequence  
<220> FEATURE:  
<223> OTHER INFORMATION: Description of Artificial Sequence: Synthetic oligonucleotide  
<220> FEATURE:  
<223> OTHER INFORMATION: Description of Combined DNA/RNA Molecule: Synthetic oligonucleotide  
  
<400> SEQUENCE: 108  
ggttccaagg ttggcattca uaaauuguu ucacaccaa 39  
  
<210> SEQ ID NO 109  
<211> LENGTH: 10  
<212> TYPE: DNA  
<213> ORGANISM: Artificial Sequence  
<220> FEATURE:  
<223> OTHER INFORMATION: Description of Artificial Sequence: Synthetic oligonucleotide  
<220> FEATURE:  
<223> OTHER INFORMATION: Description of Combined DNA/RNA Molecule: Synthetic oligonucleotide  
  
<400> SEQUENCE: 109  
ugccaacctt 10  
  
<210> SEQ ID NO 110  
<211> LENGTH: 10  
<212> TYPE: DNA  
<213> ORGANISM: Artificial Sequence  
<220> FEATURE:  
<223> OTHER INFORMATION: Description of Artificial Sequence: Synthetic oligonucleotide  
<220> FEATURE:  
<223> OTHER INFORMATION: Description of Combined DNA/RNA Molecule: Synthetic oligonucleotide  
  
<400> SEQUENCE: 110  
aaggttggca 10  
  
<210> SEQ ID NO 111  
<211> LENGTH: 12  
<212> TYPE: DNA  
<213> ORGANISM: Artificial Sequence  
<220> FEATURE:  
<223> OTHER INFORMATION: Description of Artificial Sequence: Synthetic oligonucleotide  
  
<400> SEQUENCE: 111  
tgccaacctt gg 12  
  
<210> SEQ ID NO 112  
<211> LENGTH: 12  
<212> TYPE: DNA  
<213> ORGANISM: Artificial Sequence

---

-continued

---

<220> FEATURE:  
<223> OTHER INFORMATION: Description of Artificial Sequence: Synthetic oligonucleotide

<400> SEQUENCE: 112

ccaaggttgg ca 12

<210> SEQ ID NO 113  
<211> LENGTH: 16  
<212> TYPE: DNA  
<213> ORGANISM: Artificial Sequence  
<220> FEATURE:  
<223> OTHER INFORMATION: Description of Artificial Sequence: Synthetic oligonucleotide

<400> SEQUENCE: 113

tgccaacctt ggaacc 16

<210> SEQ ID NO 114  
<211> LENGTH: 16  
<212> TYPE: DNA  
<213> ORGANISM: Artificial Sequence  
<220> FEATURE:  
<223> OTHER INFORMATION: Description of Artificial Sequence: Synthetic oligonucleotide

<400> SEQUENCE: 114

ggttccaagg ttggca 16

<210> SEQ ID NO 115  
<211> LENGTH: 27  
<212> TYPE: RNA  
<213> ORGANISM: Artificial Sequence  
<220> FEATURE:  
<223> OTHER INFORMATION: Description of Artificial Sequence: Synthetic oligonucleotide

<400> SEQUENCE: 115

ggcaauaca caaagaaagc ccucccg 27

<210> SEQ ID NO 116  
<211> LENGTH: 27  
<212> TYPE: RNA  
<213> ORGANISM: Artificial Sequence  
<220> FEATURE:  
<223> OTHER INFORMATION: Description of Artificial Sequence: Synthetic oligonucleotide

<400> SEQUENCE: 116

ggcaauaca caaagaaagc ccuccag 27

<210> SEQ ID NO 117  
<211> LENGTH: 25  
<212> TYPE: DNA  
<213> ORGANISM: Artificial Sequence  
<220> FEATURE:  
<223> OTHER INFORMATION: Description of Artificial Sequence: Synthetic oligonucleotide

<220> FEATURE:  
<223> OTHER INFORMATION: Description of Combined DNA/RNA Molecule: Synthetic oligonucleotide

<400> SEQUENCE: 117

cgagggcuuu cuuuguguau uugcc 25

---

-continued

---

<210> SEQ ID NO 118  
<211> LENGTH: 27  
<212> TYPE: RNA  
<213> ORGANISM: Artificial Sequence  
<220> FEATURE:  
<223> OTHER INFORMATION: Description of Artificial Sequence: Synthetic  
oligonucleotide

<400> SEQUENCE: 118  
ggcaaaauaca caaagaaagc ccucgag 27

<210> SEQ ID NO 119  
<211> LENGTH: 25  
<212> TYPE: DNA  
<213> ORGANISM: Artificial Sequence  
<220> FEATURE:  
<223> OTHER INFORMATION: Description of Artificial Sequence: Synthetic  
oligonucleotide  
<220> FEATURE:  
<223> OTHER INFORMATION: Description of Combined DNA/RNA Molecule:  
Synthetic oligonucleotide

<400> SEQUENCE: 119  
ccagggcuuu cuuuguguau uugcc 25

<210> SEQ ID NO 120  
<211> LENGTH: 27  
<212> TYPE: RNA  
<213> ORGANISM: Artificial Sequence  
<220> FEATURE:  
<223> OTHER INFORMATION: Description of Artificial Sequence: Synthetic  
oligonucleotide

<400> SEQUENCE: 120  
ggcaaaauaca caaagaaagc ccuggag 27

<210> SEQ ID NO 121  
<211> LENGTH: 25  
<212> TYPE: DNA  
<213> ORGANISM: Artificial Sequence  
<220> FEATURE:  
<223> OTHER INFORMATION: Description of Artificial Sequence: Synthetic  
oligonucleotide  
<220> FEATURE:  
<223> OTHER INFORMATION: Description of Combined DNA/RNA Molecule:  
Synthetic oligonucleotide

<400> SEQUENCE: 121  
ccugggcuuu cuuuguguau uugcc 25

<210> SEQ ID NO 122  
<211> LENGTH: 27  
<212> TYPE: RNA  
<213> ORGANISM: Artificial Sequence  
<220> FEATURE:  
<223> OTHER INFORMATION: Description of Artificial Sequence: Synthetic  
oligonucleotide

<400> SEQUENCE: 122  
ggcaaaauaca caaagaaagc ccaggag 27

<210> SEQ ID NO 123  
<211> LENGTH: 25  
<212> TYPE: DNA  
<213> ORGANISM: Artificial Sequence

---

-continued

---

<220> FEATURE:  
<223> OTHER INFORMATION: Description of Artificial Sequence: Synthetic oligonucleotide  
<220> FEATURE:  
<223> OTHER INFORMATION: Description of Combined DNA/RNA Molecule: Synthetic oligonucleotide  
<400> SEQUENCE: 123  
ccucggcuuu cuuuguguau uugcc 25  
  
<210> SEQ ID NO 124  
<211> LENGTH: 27  
<212> TYPE: RNA  
<213> ORGANISM: Artificial Sequence  
<220> FEATURE:  
<223> OTHER INFORMATION: Description of Artificial Sequence: Synthetic oligonucleotide  
<400> SEQUENCE: 124  
ggcaaaauaca caaagaaagc cgaggag 27  
  
<210> SEQ ID NO 125  
<211> LENGTH: 27  
<212> TYPE: RNA  
<213> ORGANISM: Artificial Sequence  
<220> FEATURE:  
<223> OTHER INFORMATION: Description of Artificial Sequence: Synthetic oligonucleotide  
<400> SEQUENCE: 125  
ggcaaaauaca caaagaaagc ccucgcc 27  
  
<210> SEQ ID NO 126  
<211> LENGTH: 27  
<212> TYPE: RNA  
<213> ORGANISM: Artificial Sequence  
<220> FEATURE:  
<223> OTHER INFORMATION: Description of Artificial Sequence: Synthetic oligonucleotide  
<400> SEQUENCE: 126  
ggcaaaauaca caaagaaagc ccuggcc 27  
  
<210> SEQ ID NO 127  
<211> LENGTH: 27  
<212> TYPE: RNA  
<213> ORGANISM: Artificial Sequence  
<220> FEATURE:  
<223> OTHER INFORMATION: Description of Artificial Sequence: Synthetic oligonucleotide  
<400> SEQUENCE: 127  
ggcaaaauaca caaagaaagc ccaggcc 27  
  
<210> SEQ ID NO 128  
<211> LENGTH: 27  
<212> TYPE: RNA  
<213> ORGANISM: Artificial Sequence  
<220> FEATURE:  
<223> OTHER INFORMATION: Description of Artificial Sequence: Synthetic oligonucleotide  
<400> SEQUENCE: 128  
ggcaaaauaca caaagaaagc cgaggcc 27



---

-continued

---

<210> SEQ ID NO 129  
<211> LENGTH: 39  
<212> TYPE: DNA  
<213> ORGANISM: Artificial Sequence  
<220> FEATURE:  
<223> OTHER INFORMATION: Description of Artificial Sequence: Synthetic  
oligonucleotide  
<220> FEATURE:  
<223> OTHER INFORMATION: Description of Combined DNA/RNA Molecule:  
Synthetic oligonucleotide  
<220> FEATURE:  
<221> NAME/KEY: modified\_base  
<222> LOCATION: (24)..(39)  
<223> OTHER INFORMATION: a, c, t, g, unknown or other and this region  
may encompass 4 to 16 bases

<400> SEQUENCE: 129

gccagacuuu guuggauuug aaannnnnnn nnnnnnnnn 39

<210> SEQ ID NO 130  
<211> LENGTH: 43  
<212> TYPE: DNA  
<213> ORGANISM: Artificial Sequence  
<220> FEATURE:  
<223> OTHER INFORMATION: Description of Artificial Sequence: Synthetic  
oligonucleotide  
<220> FEATURE:  
<223> OTHER INFORMATION: Description of Combined DNA/RNA Molecule:  
Synthetic oligonucleotide  
<220> FEATURE:  
<221> NAME/KEY: misc\_feature  
<222> LOCATION: (40)..(43)  
<223> OTHER INFORMATION: This region may encompass 0 to 4 bases  
<220> FEATURE:  
<221> NAME/KEY: modified\_base  
<222> LOCATION: (1)..(16)  
<223> OTHER INFORMATION: a, c, t, g, unknown or other and this region  
may encompass 4 to 16 bases

<400> SEQUENCE: 130

nnnnnnnnn nnnnnnuuc aaauccaaca aagucuggcu uuu 43

<210> SEQ ID NO 131  
<211> LENGTH: 41  
<212> TYPE: DNA  
<213> ORGANISM: Artificial Sequence  
<220> FEATURE:  
<223> OTHER INFORMATION: Description of Artificial Sequence: Synthetic  
oligonucleotide  
<220> FEATURE:  
<223> OTHER INFORMATION: Description of Combined DNA/RNA Molecule:  
Synthetic oligonucleotide  
<220> FEATURE:  
<221> NAME/KEY: modified\_base  
<222> LOCATION: (24)..(39)  
<223> OTHER INFORMATION: a, c, t, g, unknown or other and this region  
may encompass 4 to 16 bases

<400> SEQUENCE: 131

gccagacuuu guuggauuug aaannnnnnn nnnnnnnnc c 41

<210> SEQ ID NO 132  
<211> LENGTH: 45  
<212> TYPE: DNA  
<213> ORGANISM: Artificial Sequence  
<220> FEATURE:  
<223> OTHER INFORMATION: Description of Artificial Sequence: Synthetic  
oligonucleotide  
<220> FEATURE:

---

-continued

---

<223> OTHER INFORMATION: Description of Combined DNA/RNA Molecule:  
Synthetic oligonucleotide

<220> FEATURE:  
<221> NAME/KEY: misc\_feature  
<222> LOCATION: (42)..(45)  
<223> OTHER INFORMATION: This region may encompass 0 to 4 bases

<220> FEATURE:  
<221> NAME/KEY: modified\_base  
<222> LOCATION: (3)..(18)  
<223> OTHER INFORMATION: a, c, t, g, unknown or other and this region  
may encompass 4 to 16 bases

<400> SEQUENCE: 132

ggnnnnnnnn nnnnnnnuu ucaaauccaa caaagucugg cuuuu 45

<210> SEQ ID NO 133  
<211> LENGTH: 43  
<212> TYPE: DNA  
<213> ORGANISM: Artificial Sequence

<220> FEATURE:  
<223> OTHER INFORMATION: Description of Artificial Sequence: Synthetic  
oligonucleotide

<220> FEATURE:  
<223> OTHER INFORMATION: Description of Combined DNA/RNA Molecule:  
Synthetic oligonucleotide

<220> FEATURE:  
<221> NAME/KEY: misc\_feature  
<222> LOCATION: (40)..(43)  
<223> OTHER INFORMATION: This region may encompass 1 to 4 bases

<220> FEATURE:  
<221> NAME/KEY: modified\_base  
<222> LOCATION: (24)..(39)  
<223> OTHER INFORMATION: a, c, t, g, unknown or other and this region  
may encompass 4 to 16 bases

<400> SEQUENCE: 133

gccagacuuu guuggauuug aaannnnnnn nnnnnnnnu uuu 43

<210> SEQ ID NO 134  
<211> LENGTH: 41  
<212> TYPE: DNA  
<213> ORGANISM: Artificial Sequence

<220> FEATURE:  
<223> OTHER INFORMATION: Description of Artificial Sequence: Synthetic  
oligonucleotide

<220> FEATURE:  
<223> OTHER INFORMATION: Description of Combined DNA/RNA Molecule:  
Synthetic oligonucleotide

<220> FEATURE:  
<221> NAME/KEY: modified\_base  
<222> LOCATION: (24)..(39)  
<223> OTHER INFORMATION: a, c, t, g, unknown or other and this region  
may encompass 4 to 16 bases

<400> SEQUENCE: 134

gccagacuuu guuggauuug aaannnnnnn nnnnnnnng u 41

<210> SEQ ID NO 135  
<211> LENGTH: 45  
<212> TYPE: DNA  
<213> ORGANISM: Artificial Sequence

<220> FEATURE:  
<223> OTHER INFORMATION: Description of Artificial Sequence: Synthetic  
oligonucleotide

<220> FEATURE:  
<223> OTHER INFORMATION: Description of Combined DNA/RNA Molecule:  
Synthetic oligonucleotide

<220> FEATURE:  
<221> NAME/KEY: misc\_feature  
<222> LOCATION: (42)..(45)

---

-continued

---

<223> OTHER INFORMATION: This region may encompass 0 to 4 bases  
<220> FEATURE:  
<221> NAME/KEY: modified\_base  
<222> LOCATION: (3)..(18)  
<223> OTHER INFORMATION: a, c, t, g, unknown or other and this region  
may encompass 4 to 16 bases

<400> SEQUENCE: 135

gunnnnnnnn nnnnnnnnuu ucaaauccea caaagucugg cuuuu 45

<210> SEQ ID NO 136  
<211> LENGTH: 39  
<212> TYPE: DNA  
<213> ORGANISM: Artificial Sequence  
<220> FEATURE:  
<223> OTHER INFORMATION: Description of Artificial Sequence: Synthetic  
oligonucleotide  
<220> FEATURE:  
<223> OTHER INFORMATION: Description of Combined DNA/RNA Molecule:  
Synthetic oligonucleotide  
<220> FEATURE:  
<221> NAME/KEY: modified\_base  
<222> LOCATION: (24)..(39)  
<223> OTHER INFORMATION: a, c, t, g, unknown or other and this region  
may encompass 4 to 16 bases

<400> SEQUENCE: 136

ggagggcuuu cuuuguguac caannnnnnn nnnnnnnnn 39

<210> SEQ ID NO 137  
<211> LENGTH: 43  
<212> TYPE: DNA  
<213> ORGANISM: Artificial Sequence  
<220> FEATURE:  
<223> OTHER INFORMATION: Description of Artificial Sequence: Synthetic  
oligonucleotide  
<220> FEATURE:  
<223> OTHER INFORMATION: Description of Combined DNA/RNA Molecule:  
Synthetic oligonucleotide  
<220> FEATURE:  
<221> NAME/KEY: misc\_feature  
<222> LOCATION: (40)..(43)  
<223> OTHER INFORMATION: This region may encompass 0 to 4 bases  
<220> FEATURE:  
<221> NAME/KEY: modified\_base  
<222> LOCATION: (1)..(16)  
<223> OTHER INFORMATION: a, c, t, g, unknown or other and this region  
may encompass 4 to 16 bases

<400> SEQUENCE: 137

nnnnnnnnnn nnnnnnuugg uacacaaaga aaguccuccc ccc 43

<210> SEQ ID NO 138  
<211> LENGTH: 41  
<212> TYPE: DNA  
<213> ORGANISM: Artificial Sequence  
<220> FEATURE:  
<223> OTHER INFORMATION: Description of Artificial Sequence: Synthetic  
oligonucleotide  
<220> FEATURE:  
<223> OTHER INFORMATION: Description of Combined DNA/RNA Molecule:  
Synthetic oligonucleotide  
<220> FEATURE:  
<221> NAME/KEY: modified\_base  
<222> LOCATION: (24)..(39)  
<223> OTHER INFORMATION: a, c, t, g, unknown or other and this region  
may encompass 4 to 16 bases

<400> SEQUENCE: 138

-continued

---

ggagggcuuu cuuuguguac caannnnnnn nnnnnnnnc c 41

<210> SEQ ID NO 139  
<211> LENGTH: 45  
<212> TYPE: DNA  
<213> ORGANISM: Artificial Sequence  
<220> FEATURE:  
<223> OTHER INFORMATION: Description of Artificial Sequence: Synthetic  
oligonucleotide  
<220> FEATURE:  
<223> OTHER INFORMATION: Description of Combined DNA/RNA Molecule:  
Synthetic oligonucleotide  
<220> FEATURE:  
<221> NAME/KEY: misc\_feature  
<222> LOCATION: (42)..(45)  
<223> OTHER INFORMATION: This region may encompass 0 to 4 bases  
<220> FEATURE:  
<221> NAME/KEY: modified\_base  
<222> LOCATION: (3)..(18)  
<223> OTHER INFORMATION: a, c, t, g, unknown or other and this region  
may encompass 4 to 16 bases  
  
<400> SEQUENCE: 139

ggnnnnnnnn nnnnnnnuu gguacacaaa gaaaguccuc ccccc 45

<210> SEQ ID NO 140  
<211> LENGTH: 39  
<212> TYPE: DNA  
<213> ORGANISM: Artificial Sequence  
<220> FEATURE:  
<223> OTHER INFORMATION: Description of Artificial Sequence: Synthetic  
oligonucleotide  
<220> FEATURE:  
<223> OTHER INFORMATION: Description of Combined DNA/RNA Molecule:  
Synthetic oligonucleotide  
<220> FEATURE:  
<221> NAME/KEY: modified\_base  
<222> LOCATION: (24)..(39)  
<223> OTHER INFORMATION: a, c, t, g, unknown or other and this region  
may encompass 4 to 16 bases  
  
<400> SEQUENCE: 140

ggaggacuuu cuuuguguac caannnnnnn nnnnnnnnn 39

<210> SEQ ID NO 141  
<211> LENGTH: 43  
<212> TYPE: DNA  
<213> ORGANISM: Artificial Sequence  
<220> FEATURE:  
<223> OTHER INFORMATION: Description of Artificial Sequence: Synthetic  
oligonucleotide  
<220> FEATURE:  
<223> OTHER INFORMATION: Description of Combined DNA/RNA Molecule:  
Synthetic oligonucleotide  
<220> FEATURE:  
<221> NAME/KEY: misc\_feature  
<222> LOCATION: (40)..(43)  
<223> OTHER INFORMATION: This region may encompass 1 to 4 bases  
<220> FEATURE:  
<221> NAME/KEY: modified\_base  
<222> LOCATION: (24)..(39)  
<223> OTHER INFORMATION: a, c, t, g, unknown or other and this region  
may encompass 4 to 16 bases  
  
<400> SEQUENCE: 141

ggagggcuuu cuuuguguac caannnnnnn nnnnnnnnu uuu 43

<210> SEQ ID NO 142  
<211> LENGTH: 43

---

-continued

<212> TYPE: DNA  
<213> ORGANISM: Artificial Sequence  
<220> FEATURE:  
<223> OTHER INFORMATION: Description of Artificial Sequence: Synthetic  
oligonucleotide  
<220> FEATURE:  
<223> OTHER INFORMATION: Description of Combined DNA/RNA Molecule:  
Synthetic oligonucleotide  
<220> FEATURE:  
<221> NAME/KEY: misc\_feature  
<222> LOCATION: (40)..(43)  
<223> OTHER INFORMATION: This region may encompass 1 to 4 bases  
<220> FEATURE:  
<221> NAME/KEY: modified\_base  
<222> LOCATION: (24)..(39)  
<223> OTHER INFORMATION: a, c, t, g, unknown or other and this region  
may encompass 4 to 16 bases  
  
<400> SEQUENCE: 142

ggaggacuuu cuuuguguac caannnnnnn nnnnnnnnu uuu 43

<210> SEQ ID NO 143  
<211> LENGTH: 41  
<212> TYPE: DNA  
<213> ORGANISM: Artificial Sequence  
<220> FEATURE:  
<223> OTHER INFORMATION: Description of Artificial Sequence: Synthetic  
oligonucleotide  
<220> FEATURE:  
<223> OTHER INFORMATION: Description of Combined DNA/RNA Molecule:  
Synthetic oligonucleotide  
<220> FEATURE:  
<221> NAME/KEY: modified\_base  
<222> LOCATION: (24)..(39)  
<223> OTHER INFORMATION: a, c, t, g, unknown or other and this region  
may encompass 4 to 16 bases

<400> SEQUENCE: 143

ggagggcuuu cuuuguguac caannnnnnn nnnnnnnng u 41

<210> SEQ ID NO 144  
<211> LENGTH: 45  
<212> TYPE: DNA  
<213> ORGANISM: Artificial Sequence  
<220> FEATURE:  
<223> OTHER INFORMATION: Description of Artificial Sequence: Synthetic  
oligonucleotide  
<220> FEATURE:  
<223> OTHER INFORMATION: Description of Combined DNA/RNA Molecule:  
Synthetic oligonucleotide  
<220> FEATURE:  
<221> NAME/KEY: misc\_feature  
<222> LOCATION: (42)..(45)  
<223> OTHER INFORMATION: This region may encompass 0 to 4 bases  
<220> FEATURE:  
<221> NAME/KEY: modified\_base  
<222> LOCATION: (3)..(18)  
<223> OTHER INFORMATION: a, c, t, g, unknown or other and this region  
may encompass 4 to 16 bases

<400> SEQUENCE: 144

gunnnnnnnn nnnnnnnnuu gguacacaaa gaaaguccuc ccccc 45

<210> SEQ ID NO 145  
<211> LENGTH: 41  
<212> TYPE: DNA  
<213> ORGANISM: Artificial Sequence  
<220> FEATURE:  
<223> OTHER INFORMATION: Description of Artificial Sequence: Synthetic  
oligonucleotide

---

-continued

---

<220> FEATURE:  
<223> OTHER INFORMATION: Description of Combined DNA/RNA Molecule:  
Synthetic oligonucleotide  
<220> FEATURE:  
<221> NAME/KEY: modified\_base  
<222> LOCATION: (24)..(39)  
<223> OTHER INFORMATION: a, c, t, g, unknown or other and this region  
may encompass 4 to 16 bases  
  
<400> SEQUENCE: 145  
  
ggaggacuuu cuuuguguac caannnnnnn nnnnnnnng u 41  
  
<210> SEQ ID NO 146  
<211> LENGTH: 41  
<212> TYPE: DNA  
<213> ORGANISM: Artificial Sequence  
<220> FEATURE:  
<223> OTHER INFORMATION: Description of Artificial Sequence: Synthetic  
oligonucleotide  
<220> FEATURE:  
<223> OTHER INFORMATION: Description of Combined DNA/RNA Molecule:  
Synthetic oligonucleotide  
<220> FEATURE:  
<221> NAME/KEY: modified\_base  
<222> LOCATION: (1)..(16)  
<223> OTHER INFORMATION: a, c, t, g, unknown or other and this region  
may encompass 4 to 16 bases  
  
<400> SEQUENCE: 146  
  
nnnnnnnnn nnnnnnuaa gccagacuuu guuggauuug a 41  
  
<210> SEQ ID NO 147  
<211> LENGTH: 41  
<212> TYPE: DNA  
<213> ORGANISM: Artificial Sequence  
<220> FEATURE:  
<223> OTHER INFORMATION: Description of Artificial Sequence: Synthetic  
oligonucleotide  
<220> FEATURE:  
<223> OTHER INFORMATION: Description of Combined DNA/RNA Molecule:  
Synthetic oligonucleotide  
<220> FEATURE:  
<221> NAME/KEY: modified\_base  
<222> LOCATION: (26)..(41)  
<223> OTHER INFORMATION: a, c, t, g, unknown or other and this region  
may encompass 4 to 16 bases  
  
<400> SEQUENCE: 147  
  
tcaaauccea caaagucugg cuaaannnnn nnnnnnnnn n 41  
  
<210> SEQ ID NO 148  
<211> LENGTH: 39  
<212> TYPE: DNA  
<213> ORGANISM: Artificial Sequence  
<220> FEATURE:  
<223> OTHER INFORMATION: Description of Artificial Sequence: Synthetic  
oligonucleotide  
<220> FEATURE:  
<223> OTHER INFORMATION: Description of Combined DNA/RNA Molecule:  
Synthetic oligonucleotide  
<220> FEATURE:  
<221> NAME/KEY: modified\_base  
<222> LOCATION: (24)..(39)  
<223> OTHER INFORMATION: a, c, t, g, unknown or other and this region  
may encompass 4 to 16 bases  
  
<400> SEQUENCE: 148  
  
aaaaccaaca aagucuggcu uaannnnnnn nnnnnnnnn 39

---

-continued

---

<210> SEQ ID NO 149  
<211> LENGTH: 43  
<212> TYPE: DNA  
<213> ORGANISM: Artificial Sequence  
<220> FEATURE:  
<223> OTHER INFORMATION: Description of Artificial Sequence: Synthetic oligonucleotide  
<220> FEATURE:  
<223> OTHER INFORMATION: Description of Combined DNA/RNA Molecule: Synthetic oligonucleotide  
<220> FEATURE:  
<221> NAME/KEY: misc\_feature  
<222> LOCATION: (40)..(43)  
<223> OTHER INFORMATION: This region may encompass 1 to 4 bases  
<220> FEATURE:  
<221> NAME/KEY: modified\_base  
<222> LOCATION: (1)..(16)  
<223> OTHER INFORMATION: a, c, t, g, unknown or other and this region may encompass 4 to 16 bases

<400> SEQUENCE: 149

nnnnnnnnnn nnnnnnuuaa gccagacuuu guuggauuuu uuu 43

<210> SEQ ID NO 150  
<211> LENGTH: 41  
<212> TYPE: DNA  
<213> ORGANISM: Artificial Sequence  
<220> FEATURE:  
<223> OTHER INFORMATION: Description of Artificial Sequence: Synthetic oligonucleotide  
<220> FEATURE:  
<223> OTHER INFORMATION: Description of Combined DNA/RNA Molecule: Synthetic oligonucleotide  
<220> FEATURE:  
<221> NAME/KEY: modified\_base  
<222> LOCATION: (26)..(41)  
<223> OTHER INFORMATION: a, c, t, g, unknown or other and this region may encompass 4 to 16 bases

<400> SEQUENCE: 150

guaaauccaa caaagucugg cuuaannnnn nnnnnnnnnn n 41

<210> SEQ ID NO 151  
<211> LENGTH: 41  
<212> TYPE: DNA  
<213> ORGANISM: Artificial Sequence  
<220> FEATURE:  
<223> OTHER INFORMATION: Description of Artificial Sequence: Synthetic oligonucleotide  
<220> FEATURE:  
<223> OTHER INFORMATION: Description of Combined DNA/RNA Molecule: Synthetic oligonucleotide  
<220> FEATURE:  
<221> NAME/KEY: modified\_base  
<222> LOCATION: (1)..(16)  
<223> OTHER INFORMATION: a, c, t, g, unknown or other and this region may encompass 4 to 16 bases

<400> SEQUENCE: 151

nnnnnnnnnn nnnnnnuuaa gccagacuuu guuggauuug a 41

<210> SEQ ID NO 152  
<211> LENGTH: 41  
<212> TYPE: DNA  
<213> ORGANISM: Artificial Sequence  
<220> FEATURE:  
<223> OTHER INFORMATION: Description of Artificial Sequence: Synthetic oligonucleotide  
<220> FEATURE:

---

-continued

---

<223> OTHER INFORMATION: Description of Combined DNA/RNA Molecule:  
Synthetic oligonucleotide  
<220> FEATURE:  
<221> NAME/KEY: modified\_base  
<222> LOCATION: (26)..(41)  
<223> OTHER INFORMATION: a, c, t, g, unknown or other and this region  
may encompass 4 to 16 bases  
  
<400> SEQUENCE: 152  
  
tcaaauccaa caaaggcugg cuaaannnnn nnnnnnnnnn n  
41  
  
<210> SEQ ID NO 153  
<211> LENGTH: 41  
<212> TYPE: DNA  
<213> ORGANISM: Artificial Sequence  
<220> FEATURE:  
<223> OTHER INFORMATION: Description of Artificial Sequence: Synthetic  
oligonucleotide  
<220> FEATURE:  
<223> OTHER INFORMATION: Description of Combined DNA/RNA Molecule:  
Synthetic oligonucleotide  
<220> FEATURE:  
<221> NAME/KEY: modified\_base  
<222> LOCATION: (1)..(16)  
<223> OTHER INFORMATION: a, c, t, g, unknown or other and this region  
may encompass 4 to 16 bases  
  
<400> SEQUENCE: 153  
  
nnnnnnnnnn nnnnnnuuaa gccugacuuu guuggauuug a  
41  
  
<210> SEQ ID NO 154  
<211> LENGTH: 41  
<212> TYPE: DNA  
<213> ORGANISM: Artificial Sequence  
<220> FEATURE:  
<223> OTHER INFORMATION: Description of Artificial Sequence: Synthetic  
oligonucleotide  
<220> FEATURE:  
<223> OTHER INFORMATION: Description of Combined DNA/RNA Molecule:  
Synthetic oligonucleotide  
<220> FEATURE:  
<221> NAME/KEY: modified\_base  
<222> LOCATION: (26)..(41)  
<223> OTHER INFORMATION: a, c, t, g, unknown or other and this region  
may encompass 4 to 16 bases  
  
<400> SEQUENCE: 154  
  
tcaaauccaa caaagucggg cuaaannnnn nnnnnnnnnn n  
41  
  
<210> SEQ ID NO 155  
<211> LENGTH: 41  
<212> TYPE: DNA  
<213> ORGANISM: Artificial Sequence  
<220> FEATURE:  
<223> OTHER INFORMATION: Description of Artificial Sequence: Synthetic  
oligonucleotide  
<220> FEATURE:  
<223> OTHER INFORMATION: Description of Combined DNA/RNA Molecule:  
Synthetic oligonucleotide  
<220> FEATURE:  
<221> NAME/KEY: modified\_base  
<222> LOCATION: (1)..(16)  
<223> OTHER INFORMATION: a, c, t, g, unknown or other and this region  
may encompass 4 to 16 bases  
  
<400> SEQUENCE: 155  
  
nnnnnnnnnn nnnnnnuuaa gccagccuuu guuggauuug a  
41



---

-continued

---

<210> SEQ ID NO 156  
<211> LENGTH: 41  
<212> TYPE: DNA  
<213> ORGANISM: Artificial Sequence  
<220> FEATURE:  
<223> OTHER INFORMATION: Description of Artificial Sequence: Synthetic  
oligonucleotide  
<220> FEATURE:  
<223> OTHER INFORMATION: Description of Combined DNA/RNA Molecule:  
Synthetic oligonucleotide  
<220> FEATURE:  
<221> NAME/KEY: modified\_base  
<222> LOCATION: (1)..(16)  
<223> OTHER INFORMATION: a, c, t, g, unknown or other and this region  
may encompass 4 to 16 bases

<400> SEQUENCE: 156

nnnnnnnnnn nnnnnnuuaa gcccgacuuu guuggauuug a 41

<210> SEQ ID NO 157  
<211> LENGTH: 43  
<212> TYPE: DNA  
<213> ORGANISM: Artificial Sequence  
<220> FEATURE:  
<223> OTHER INFORMATION: Description of Artificial Sequence: Synthetic  
oligonucleotide  
<220> FEATURE:  
<223> OTHER INFORMATION: Description of Combined DNA/RNA Molecule:  
Synthetic oligonucleotide  
<220> FEATURE:  
<221> NAME/KEY: misc\_feature  
<222> LOCATION: (40)..(43)  
<223> OTHER INFORMATION: This region may encompass 1 to 4 bases  
<220> FEATURE:  
<221> NAME/KEY: modified\_base  
<222> LOCATION: (1)..(16)  
<223> OTHER INFORMATION: a, c, t, g, unknown or other and this region  
may encompass 4 to 16 bases

<400> SEQUENCE: 157

nnnnnnnnnn nnnnnnuuaa gccagacuuu guuggauuuu uu 43

<210> SEQ ID NO 158  
<211> LENGTH: 39  
<212> TYPE: DNA  
<213> ORGANISM: Artificial Sequence  
<220> FEATURE:  
<223> OTHER INFORMATION: Description of Artificial Sequence: Synthetic  
oligonucleotide  
<220> FEATURE:  
<223> OTHER INFORMATION: Description of Combined DNA/RNA Molecule:  
Synthetic oligonucleotide  
<220> FEATURE:  
<221> NAME/KEY: modified\_base  
<222> LOCATION: (24)..(39)  
<223> OTHER INFORMATION: a, c, t, g, unknown or other and this region  
may encompass 4 to 16 bases

<400> SEQUENCE: 158

aaaaccaaca aaggcuggcu uaannnnnnn nnnnnnnnn 39

<210> SEQ ID NO 159  
<211> LENGTH: 43  
<212> TYPE: DNA  
<213> ORGANISM: Artificial Sequence  
<220> FEATURE:  
<223> OTHER INFORMATION: Description of Artificial Sequence: Synthetic  
oligonucleotide  
<220> FEATURE:  
<223> OTHER INFORMATION: Description of Combined DNA/RNA Molecule:

-continued

---

Synthetic oligonucleotide

<220> FEATURE:  
 <221> NAME/KEY: misc\_feature  
 <222> LOCATION: (40)..(43)  
 <223> OTHER INFORMATION: This region may encompass 1 to 4 bases

<220> FEATURE:  
 <221> NAME/KEY: modified\_base  
 <222> LOCATION: (1)..(16)  
 <223> OTHER INFORMATION: a, c, t, g, unknown or other and this region  
 may encompass 4 to 16 bases

<400> SEQUENCE: 159

nnnnnnnnnn nnnnnnuuaa gccagccuuu guuggauuuu uuu 43

<210> SEQ ID NO 160  
 <211> LENGTH: 41  
 <212> TYPE: DNA  
 <213> ORGANISM: Artificial Sequence  
 <220> FEATURE:  
 <223> OTHER INFORMATION: Description of Artificial Sequence: Synthetic  
 oligonucleotide

<220> FEATURE:  
 <223> OTHER INFORMATION: Description of Combined DNA/RNA Molecule:  
 Synthetic oligonucleotide

<220> FEATURE:  
 <221> NAME/KEY: modified\_base  
 <222> LOCATION: (26)..(41)  
 <223> OTHER INFORMATION: a, c, t, g, unknown or other and this region  
 may encompass 4 to 16 bases

<400> SEQUENCE: 160

guaaauccaa caaagucggg cuuaannnnn nnnnnnnnnn n 41

<210> SEQ ID NO 161  
 <211> LENGTH: 28  
 <212> TYPE: DNA  
 <213> ORGANISM: Artificial Sequence  
 <220> FEATURE:  
 <223> OTHER INFORMATION: Description of Artificial Sequence: Synthetic  
 oligonucleotide

<220> FEATURE:  
 <223> OTHER INFORMATION: Description of Combined DNA/RNA Molecule:  
 Synthetic oligonucleotide

<400> SEQUENCE: 161

gccagacuuu guuggauuug aaaccatt 28

<210> SEQ ID NO 162  
 <211> LENGTH: 30  
 <212> TYPE: DNA  
 <213> ORGANISM: Artificial Sequence  
 <220> FEATURE:  
 <223> OTHER INFORMATION: Description of Artificial Sequence: Synthetic  
 oligonucleotide

<220> FEATURE:  
 <223> OTHER INFORMATION: Description of Combined DNA/RNA Molecule:  
 Synthetic oligonucleotide

<400> SEQUENCE: 162

aatgguuuc aauccaacaa agucuggcuu 30

<210> SEQ ID NO 163  
 <211> LENGTH: 30  
 <212> TYPE: DNA  
 <213> ORGANISM: Artificial Sequence  
 <220> FEATURE:  
 <223> OTHER INFORMATION: Description of Artificial Sequence: Synthetic  
 oligonucleotide

---

-continued

---

<220> FEATURE:  
<223> OTHER INFORMATION: Description of Combined DNA/RNA Molecule:  
Synthetic oligonucleotide

<400> SEQUENCE: 163

gccagacuuu guuggauuug aaaccaactt 30

<210> SEQ ID NO 164  
<211> LENGTH: 32  
<212> TYPE: DNA  
<213> ORGANISM: Artificial Sequence  
<220> FEATURE:  
<223> OTHER INFORMATION: Description of Artificial Sequence: Synthetic  
oligonucleotide  
<220> FEATURE:  
<223> OTHER INFORMATION: Description of Combined DNA/RNA Molecule:  
Synthetic oligonucleotide

<400> SEQUENCE: 164

aagtgguuu caaauccaac aaagucuggc uu 32

<210> SEQ ID NO 165  
<211> LENGTH: 32  
<212> TYPE: DNA  
<213> ORGANISM: Artificial Sequence  
<220> FEATURE:  
<223> OTHER INFORMATION: Description of Artificial Sequence: Synthetic  
oligonucleotide  
<220> FEATURE:  
<223> OTHER INFORMATION: Description of Combined DNA/RNA Molecule:  
Synthetic oligonucleotide

<400> SEQUENCE: 165

gccagacuuu guuggauuug aaaccaacag tt 32

<210> SEQ ID NO 166  
<211> LENGTH: 34  
<212> TYPE: DNA  
<213> ORGANISM: Artificial Sequence  
<220> FEATURE:  
<223> OTHER INFORMATION: Description of Artificial Sequence: Synthetic  
oligonucleotide  
<220> FEATURE:  
<223> OTHER INFORMATION: Description of Combined DNA/RNA Molecule:  
Synthetic oligonucleotide

<400> SEQUENCE: 166

aactggttgu uucaaaacca acaaagucug gcuu 34

<210> SEQ ID NO 167  
<211> LENGTH: 34  
<212> TYPE: DNA  
<213> ORGANISM: Artificial Sequence  
<220> FEATURE:  
<223> OTHER INFORMATION: Description of Artificial Sequence: Synthetic  
oligonucleotide  
<220> FEATURE:  
<223> OTHER INFORMATION: Description of Combined DNA/RNA Molecule:  
Synthetic oligonucleotide

<400> SEQUENCE: 167

gccagacuuu guuggauuug aaaccaacag cctt 34

<210> SEQ ID NO 168  
<211> LENGTH: 36  
<212> TYPE: DNA

---

-continued

<213> ORGANISM: Artificial Sequence  
<220> FEATURE:  
<223> OTHER INFORMATION: Description of Artificial Sequence: Synthetic oligonucleotide  
<220> FEATURE:  
<223> OTHER INFORMATION: Description of Combined DNA/RNA Molecule: Synthetic oligonucleotide

<400> SEQUENCE: 168

aaggctggtg guuucaaac caacaaguc uggcuu 36

<210> SEQ ID NO 169  
<211> LENGTH: 35  
<212> TYPE: DNA  
<213> ORGANISM: Artificial Sequence  
<220> FEATURE:  
<223> OTHER INFORMATION: Description of Artificial Sequence: Synthetic oligonucleotide  
<220> FEATURE:  
<223> OTHER INFORMATION: Description of Combined DNA/RNA Molecule: Synthetic oligonucleotide

<400> SEQUENCE: 169

gccagacuuu guuggauug aaaccaacag ccatt 35

<210> SEQ ID NO 170  
<211> LENGTH: 37  
<212> TYPE: DNA  
<213> ORGANISM: Artificial Sequence  
<220> FEATURE:  
<223> OTHER INFORMATION: Description of Artificial Sequence: Synthetic oligonucleotide  
<220> FEATURE:  
<223> OTHER INFORMATION: Description of Combined DNA/RNA Molecule: Synthetic oligonucleotide

<400> SEQUENCE: 170

aatggctggt gguucaaa ccaacaagu cuggcuu 37

<210> SEQ ID NO 171  
<211> LENGTH: 36  
<212> TYPE: DNA  
<213> ORGANISM: Artificial Sequence  
<220> FEATURE:  
<223> OTHER INFORMATION: Description of Artificial Sequence: Synthetic oligonucleotide  
<220> FEATURE:  
<223> OTHER INFORMATION: Description of Combined DNA/RNA Molecule: Synthetic oligonucleotide

<400> SEQUENCE: 171

gccagacuuu guuggauug aaaccaacag ccagtt 36

<210> SEQ ID NO 172  
<211> LENGTH: 38  
<212> TYPE: DNA  
<213> ORGANISM: Artificial Sequence  
<220> FEATURE:  
<223> OTHER INFORMATION: Description of Artificial Sequence: Synthetic oligonucleotide  
<220> FEATURE:  
<223> OTHER INFORMATION: Description of Combined DNA/RNA Molecule: Synthetic oligonucleotide

<400> SEQUENCE: 172

aactggctgt tgguucaaa uccaacaag ucuggcuu 38

---

-continued

---

<210> SEQ ID NO 173  
<211> LENGTH: 37  
<212> TYPE: DNA  
<213> ORGANISM: Artificial Sequence  
<220> FEATURE:  
<223> OTHER INFORMATION: Description of Artificial Sequence: Synthetic  
oligonucleotide  
<220> FEATURE:  
<223> OTHER INFORMATION: Description of Combined DNA/RNA Molecule:  
Synthetic oligonucleotide  
  
<400> SEQUENCE: 173  
gccagacuuu guuggauug aaaccaacag ccagctt 37

<210> SEQ ID NO 174  
<211> LENGTH: 39  
<212> TYPE: DNA  
<213> ORGANISM: Artificial Sequence  
<220> FEATURE:  
<223> OTHER INFORMATION: Description of Artificial Sequence: Synthetic  
oligonucleotide  
<220> FEATURE:  
<223> OTHER INFORMATION: Description of Combined DNA/RNA Molecule:  
Synthetic oligonucleotide  
  
<400> SEQUENCE: 174  
aagctggctg ttgguucaa auccaacaaa gucuggcuu 39

<210> SEQ ID NO 175  
<211> LENGTH: 38  
<212> TYPE: DNA  
<213> ORGANISM: Artificial Sequence  
<220> FEATURE:  
<223> OTHER INFORMATION: Description of Artificial Sequence: Synthetic  
oligonucleotide  
<220> FEATURE:  
<223> OTHER INFORMATION: Description of Combined DNA/RNA Molecule:  
Synthetic oligonucleotide  
  
<400> SEQUENCE: 175  
gccagacuuu guuggauug aaaccaacag ccagcatt 38

<210> SEQ ID NO 176  
<211> LENGTH: 40  
<212> TYPE: DNA  
<213> ORGANISM: Artificial Sequence  
<220> FEATURE:  
<223> OTHER INFORMATION: Description of Artificial Sequence: Synthetic  
oligonucleotide  
<220> FEATURE:  
<223> OTHER INFORMATION: Description of Combined DNA/RNA Molecule:  
Synthetic oligonucleotide  
  
<400> SEQUENCE: 176  
aatgctggct gttgguuca auccaacaaa agucuggcuu 40

<210> SEQ ID NO 177  
<211> LENGTH: 39  
<212> TYPE: DNA  
<213> ORGANISM: Artificial Sequence  
<220> FEATURE:  
<223> OTHER INFORMATION: Description of Artificial Sequence: Synthetic  
oligonucleotide  
<220> FEATURE:  
<223> OTHER INFORMATION: Description of Combined DNA/RNA Molecule:  
Synthetic oligonucleotide

---

-continued

---

<400> SEQUENCE: 177

gccagacuuu guuggauuug aaaccaacag ccagcactt 39

<210> SEQ ID NO 178

<211> LENGTH: 41

<212> TYPE: DNA

<213> ORGANISM: Artificial Sequence

<220> FEATURE:

<223> OTHER INFORMATION: Description of Artificial Sequence: Synthetic oligonucleotide

<220> FEATURE:

<223> OTHER INFORMATION: Description of Combined DNA/RNA Molecule: Synthetic oligonucleotide

<400> SEQUENCE: 178

aagtgtggc tgttguuuc aaauccaaca aagucuggcu u 41

<210> SEQ ID NO 179

<211> LENGTH: 29

<212> TYPE: DNA

<213> ORGANISM: Artificial Sequence

<220> FEATURE:

<223> OTHER INFORMATION: Description of Artificial Sequence: Synthetic oligonucleotide

<220> FEATURE:

<223> OTHER INFORMATION: Description of Combined DNA/RNA Molecule: Synthetic oligonucleotide

<400> SEQUENCE: 179

gccagacuuu guuggauuug aaaccaatt 29

<210> SEQ ID NO 180

<211> LENGTH: 31

<212> TYPE: DNA

<213> ORGANISM: Artificial Sequence

<220> FEATURE:

<223> OTHER INFORMATION: Description of Artificial Sequence: Synthetic oligonucleotide

<220> FEATURE:

<223> OTHER INFORMATION: Description of Combined DNA/RNA Molecule: Synthetic oligonucleotide

<400> SEQUENCE: 180

aaugguuuc aaauccaaca aagucuggcu u 31

<210> SEQ ID NO 181

<211> LENGTH: 31

<212> TYPE: DNA

<213> ORGANISM: Artificial Sequence

<220> FEATURE:

<223> OTHER INFORMATION: Description of Artificial Sequence: Synthetic oligonucleotide

<220> FEATURE:

<223> OTHER INFORMATION: Description of Combined DNA/RNA Molecule: Synthetic oligonucleotide

<400> SEQUENCE: 181

aattgguuuc aaauccaaca aagucuggcu u 31

<210> SEQ ID NO 182

<211> LENGTH: 29

<212> TYPE: DNA

<213> ORGANISM: Artificial Sequence

<220> FEATURE:

<223> OTHER INFORMATION: Description of Artificial Sequence: Synthetic oligonucleotide

---

-continued

---

<220> FEATURE:  
<223> OTHER INFORMATION: Description of Combined DNA/RNA Molecule:  
Synthetic oligonucleotide

<400> SEQUENCE: 182

gccagacuuu guuggauuug aaaccaatt 29

<210> SEQ ID NO 183  
<211> LENGTH: 29  
<212> TYPE: DNA  
<213> ORGANISM: Artificial Sequence  
<220> FEATURE:  
<223> OTHER INFORMATION: Description of Artificial Sequence: Synthetic  
oligonucleotide  
<220> FEATURE:  
<223> OTHER INFORMATION: Description of Combined DNA/RNA Molecule:  
Synthetic oligonucleotide

<400> SEQUENCE: 183

gccagacuuu guuggauuug aaaccaauu 29

<210> SEQ ID NO 184  
<211> LENGTH: 29  
<212> TYPE: DNA  
<213> ORGANISM: Artificial Sequence  
<220> FEATURE:  
<223> OTHER INFORMATION: Description of Artificial Sequence: Synthetic  
oligonucleotide  
<220> FEATURE:  
<223> OTHER INFORMATION: Description of Combined DNA/RNA Molecule:  
Synthetic oligonucleotide

<400> SEQUENCE: 184

gccagacuuu guuggauuug aaaccaagu 29

<210> SEQ ID NO 185  
<211> LENGTH: 29  
<212> TYPE: DNA  
<213> ORGANISM: Artificial Sequence  
<220> FEATURE:  
<223> OTHER INFORMATION: Description of Artificial Sequence: Synthetic  
oligonucleotide  
<220> FEATURE:  
<223> OTHER INFORMATION: Description of Combined DNA/RNA Molecule:  
Synthetic oligonucleotide

<400> SEQUENCE: 185

guttgguuuc aaauccaaca aagucuggc 29

<210> SEQ ID NO 186  
<211> LENGTH: 29  
<212> TYPE: DNA  
<213> ORGANISM: Artificial Sequence  
<220> FEATURE:  
<223> OTHER INFORMATION: Description of Artificial Sequence: Synthetic  
oligonucleotide  
<220> FEATURE:  
<223> OTHER INFORMATION: Description of Combined DNA/RNA Molecule:  
Synthetic oligonucleotide

<400> SEQUENCE: 186

aagggccaga cuuuguugga uuugaaacc 29

<210> SEQ ID NO 187  
<211> LENGTH: 27  
<212> TYPE: DNA

---

-continued

---

<213> ORGANISM: Artificial Sequence  
<220> FEATURE:  
<223> OTHER INFORMATION: Description of Artificial Sequence: Synthetic  
oligonucleotide  
<220> FEATURE:  
<223> OTHER INFORMATION: Description of Combined DNA/RNA Molecule:  
Synthetic oligonucleotide  
  
<400> SEQUENCE: 187  
  
uuucaaaucc aacaaagucu guucctt 27  
  
<210> SEQ ID NO 188  
<211> LENGTH: 30  
<212> TYPE: DNA  
<213> ORGANISM: Artificial Sequence  
<220> FEATURE:  
<223> OTHER INFORMATION: Description of Artificial Sequence: Synthetic  
oligonucleotide  
<220> FEATURE:  
<223> OTHER INFORMATION: Description of Combined DNA/RNA Molecule:  
Synthetic oligonucleotide  
  
<400> SEQUENCE: 188  
  
aacgggccag acuuuguugg auuugaaacc 30  
  
<210> SEQ ID NO 189  
<211> LENGTH: 28  
<212> TYPE: DNA  
<213> ORGANISM: Artificial Sequence  
<220> FEATURE:  
<223> OTHER INFORMATION: Description of Artificial Sequence: Synthetic  
oligonucleotide  
<220> FEATURE:  
<223> OTHER INFORMATION: Description of Combined DNA/RNA Molecule:  
Synthetic oligonucleotide  
  
<400> SEQUENCE: 189  
  
uuucaaaucc aacaaagucu guuccggt 28  
  
<210> SEQ ID NO 190  
<211> LENGTH: 31  
<212> TYPE: DNA  
<213> ORGANISM: Artificial Sequence  
<220> FEATURE:  
<223> OTHER INFORMATION: Description of Artificial Sequence: Synthetic  
oligonucleotide  
<220> FEATURE:  
<223> OTHER INFORMATION: Description of Combined DNA/RNA Molecule:  
Synthetic oligonucleotide  
  
<400> SEQUENCE: 190  
  
aaacgggccca gacuuuguug gauuugaaac c 31  
  
<210> SEQ ID NO 191  
<211> LENGTH: 29  
<212> TYPE: DNA  
<213> ORGANISM: Artificial Sequence  
<220> FEATURE:  
<223> OTHER INFORMATION: Description of Artificial Sequence: Synthetic  
oligonucleotide  
<220> FEATURE:  
<223> OTHER INFORMATION: Description of Combined DNA/RNA Molecule:  
Synthetic oligonucleotide  
  
<400> SEQUENCE: 191  
  
uuucaaaucc aacaaagucu guuccggtt 29



---

-continued

---

<210> SEQ ID NO 192  
<211> LENGTH: 32  
<212> TYPE: DNA  
<213> ORGANISM: Artificial Sequence  
<220> FEATURE:  
<223> OTHER INFORMATION: Description of Artificial Sequence: Synthetic  
oligonucleotide  
<220> FEATURE:  
<223> OTHER INFORMATION: Description of Combined DNA/RNA Molecule:  
Synthetic oligonucleotide  
  
<400> SEQUENCE: 192  
  
aagacgggcc agacuuuguu ggauuugaaa cc 32

<210> SEQ ID NO 193  
<211> LENGTH: 30  
<212> TYPE: DNA  
<213> ORGANISM: Artificial Sequence  
<220> FEATURE:  
<223> OTHER INFORMATION: Description of Artificial Sequence: Synthetic  
oligonucleotide  
<220> FEATURE:  
<223> OTHER INFORMATION: Description of Combined DNA/RNA Molecule:  
Synthetic oligonucleotide  
  
<400> SEQUENCE: 193  
  
uuucaaaucc aacaaagucu guuccgtctt 30

<210> SEQ ID NO 194  
<211> LENGTH: 33  
<212> TYPE: DNA  
<213> ORGANISM: Artificial Sequence  
<220> FEATURE:  
<223> OTHER INFORMATION: Description of Artificial Sequence: Synthetic  
oligonucleotide  
<220> FEATURE:  
<223> OTHER INFORMATION: Description of Combined DNA/RNA Molecule:  
Synthetic oligonucleotide  
  
<400> SEQUENCE: 194  
  
aagcacgggc cagacuuugu uggauuugaa acc 33

<210> SEQ ID NO 195  
<211> LENGTH: 31  
<212> TYPE: DNA  
<213> ORGANISM: Artificial Sequence  
<220> FEATURE:  
<223> OTHER INFORMATION: Description of Artificial Sequence: Synthetic  
oligonucleotide  
<220> FEATURE:  
<223> OTHER INFORMATION: Description of Combined DNA/RNA Molecule:  
Synthetic oligonucleotide  
  
<400> SEQUENCE: 195  
  
uuucaaaucc aacaaagucu guuccgtgct t 31

<210> SEQ ID NO 196  
<211> LENGTH: 34  
<212> TYPE: DNA  
<213> ORGANISM: Artificial Sequence  
<220> FEATURE:  
<223> OTHER INFORMATION: Description of Artificial Sequence: Synthetic  
oligonucleotide  
<220> FEATURE:  
<223> OTHER INFORMATION: Description of Combined DNA/RNA Molecule:  
Synthetic oligonucleotide

---

-continued

---

<400> SEQUENCE: 196

aagccacggg ccagacuuug uuggauuga aacc 34

<210> SEQ ID NO 197

<211> LENGTH: 32

<212> TYPE: DNA

<213> ORGANISM: Artificial Sequence

<220> FEATURE:

<223> OTHER INFORMATION: Description of Artificial Sequence: Synthetic oligonucleotide

<220> FEATURE:

<223> OTHER INFORMATION: Description of Combined DNA/RNA Molecule: Synthetic oligonucleotide

<400> SEQUENCE: 197

uuucaaaucc aacaaagucu guuccgtggc tt 32

<210> SEQ ID NO 198

<211> LENGTH: 35

<212> TYPE: DNA

<213> ORGANISM: Artificial Sequence

<220> FEATURE:

<223> OTHER INFORMATION: Description of Artificial Sequence: Synthetic oligonucleotide

<220> FEATURE:

<223> OTHER INFORMATION: Description of Combined DNA/RNA Molecule: Synthetic oligonucleotide

<400> SEQUENCE: 198

aagcctacgg gccagacuuu guuggauug aaacc 35

<210> SEQ ID NO 199

<211> LENGTH: 33

<212> TYPE: DNA

<213> ORGANISM: Artificial Sequence

<220> FEATURE:

<223> OTHER INFORMATION: Description of Artificial Sequence: Synthetic oligonucleotide

<220> FEATURE:

<223> OTHER INFORMATION: Description of Combined DNA/RNA Molecule: Synthetic oligonucleotide

<400> SEQUENCE: 199

uuucaaaucc aacaaagucu guuccgtagg ctt 33

<210> SEQ ID NO 200

<211> LENGTH: 36

<212> TYPE: DNA

<213> ORGANISM: Artificial Sequence

<220> FEATURE:

<223> OTHER INFORMATION: Description of Artificial Sequence: Synthetic oligonucleotide

<220> FEATURE:

<223> OTHER INFORMATION: Description of Combined DNA/RNA Molecule: Synthetic oligonucleotide

<400> SEQUENCE: 200

aagtcctacg ggccagacuu uguuggauuu gaaacc 36

<210> SEQ ID NO 201

<211> LENGTH: 34

<212> TYPE: DNA

<213> ORGANISM: Artificial Sequence

<220> FEATURE:

<223> OTHER INFORMATION: Description of Artificial Sequence: Synthetic oligonucleotide

---

-continued

---

<220> FEATURE:  
<223> OTHER INFORMATION: Description of Combined DNA/RNA Molecule:  
Synthetic oligonucleotide

<400> SEQUENCE: 201

uuucaaaucc aacaaagucu guuccgtagg actt 34

<210> SEQ ID NO 202  
<211> LENGTH: 37  
<212> TYPE: DNA  
<213> ORGANISM: Artificial Sequence  
<220> FEATURE:  
<223> OTHER INFORMATION: Description of Artificial Sequence: Synthetic  
oligonucleotide  
<220> FEATURE:  
<223> OTHER INFORMATION: Description of Combined DNA/RNA Molecule:  
Synthetic oligonucleotide

<400> SEQUENCE: 202

aagtgcctac gggccagacu uuguuggauu ugaaacc 37

<210> SEQ ID NO 203  
<211> LENGTH: 35  
<212> TYPE: DNA  
<213> ORGANISM: Artificial Sequence  
<220> FEATURE:  
<223> OTHER INFORMATION: Description of Artificial Sequence: Synthetic  
oligonucleotide  
<220> FEATURE:  
<223> OTHER INFORMATION: Description of Combined DNA/RNA Molecule:  
Synthetic oligonucleotide

<400> SEQUENCE: 203

uuucaaaucc aacaaagucu guuccgtagg cactt 35

<210> SEQ ID NO 204  
<211> LENGTH: 38  
<212> TYPE: DNA  
<213> ORGANISM: Artificial Sequence  
<220> FEATURE:  
<223> OTHER INFORMATION: Description of Artificial Sequence: Synthetic  
oligonucleotide  
<220> FEATURE:  
<223> OTHER INFORMATION: Description of Combined DNA/RNA Molecule:  
Synthetic oligonucleotide

<400> SEQUENCE: 204

aagctgccta cgggccagac uuuguuggau uugaaacc 38

<210> SEQ ID NO 205  
<211> LENGTH: 36  
<212> TYPE: DNA  
<213> ORGANISM: Artificial Sequence  
<220> FEATURE:  
<223> OTHER INFORMATION: Description of Artificial Sequence: Synthetic  
oligonucleotide  
<220> FEATURE:  
<223> OTHER INFORMATION: Description of Combined DNA/RNA Molecule:  
Synthetic oligonucleotide

<400> SEQUENCE: 205

uuucaaaucc aacaaagucu guuccgtagg cagctt 36

<210> SEQ ID NO 206  
<211> LENGTH: 39  
<212> TYPE: DNA

-continued

---

<213> ORGANISM: Artificial Sequence  
<220> FEATURE:  
<223> OTHER INFORMATION: Description of Artificial Sequence: Synthetic  
oligonucleotide  
<220> FEATURE:  
<223> OTHER INFORMATION: Description of Combined DNA/RNA Molecule:  
Synthetic oligonucleotide

<400> SEQUENCE: 206

aacgctgcct acgggccaga cuuguugga uuugaaacc 39

<210> SEQ ID NO 207  
<211> LENGTH: 37  
<212> TYPE: DNA  
<213> ORGANISM: Artificial Sequence  
<220> FEATURE:  
<223> OTHER INFORMATION: Description of Artificial Sequence: Synthetic  
oligonucleotide  
<220> FEATURE:  
<223> OTHER INFORMATION: Description of Combined DNA/RNA Molecule:  
Synthetic oligonucleotide

<400> SEQUENCE: 207

uuucaaaacc aacaaagucu guuccgtagg cagcggt 37

<210> SEQ ID NO 208  
<211> LENGTH: 40  
<212> TYPE: DNA  
<213> ORGANISM: Artificial Sequence  
<220> FEATURE:  
<223> OTHER INFORMATION: Description of Artificial Sequence: Synthetic  
oligonucleotide  
<220> FEATURE:  
<223> OTHER INFORMATION: Description of Combined DNA/RNA Molecule:  
Synthetic oligonucleotide

<400> SEQUENCE: 208

aatcgctgcc tacgggccag acuuuguugg auuugaaacc 40

<210> SEQ ID NO 209  
<211> LENGTH: 38  
<212> TYPE: DNA  
<213> ORGANISM: Artificial Sequence  
<220> FEATURE:  
<223> OTHER INFORMATION: Description of Artificial Sequence: Synthetic  
oligonucleotide  
<220> FEATURE:  
<223> OTHER INFORMATION: Description of Combined DNA/RNA Molecule:  
Synthetic oligonucleotide

<400> SEQUENCE: 209

uuucaaaacc aacaaagucu guuccgtagg cagcgatt 38

<210> SEQ ID NO 210  
<211> LENGTH: 41  
<212> TYPE: DNA  
<213> ORGANISM: Artificial Sequence  
<220> FEATURE:  
<223> OTHER INFORMATION: Description of Artificial Sequence: Synthetic  
oligonucleotide  
<220> FEATURE:  
<223> OTHER INFORMATION: Description of Combined DNA/RNA Molecule:  
Synthetic oligonucleotide

<400> SEQUENCE: 210

aagtcgctgc ctacgggccca gacuuuguug gauuugaaac c 41

---

-continued

---

<210> SEQ ID NO 211  
<211> LENGTH: 39  
<212> TYPE: DNA  
<213> ORGANISM: Artificial Sequence  
<220> FEATURE:  
<223> OTHER INFORMATION: Description of Artificial Sequence: Synthetic  
oligonucleotide  
<220> FEATURE:  
<223> OTHER INFORMATION: Description of Combined DNA/RNA Molecule:  
Synthetic oligonucleotide  
  
<400> SEQUENCE: 211  
  
uuucaaaucc aacaaagucu guuccgtagg cagcgactt 39

<210> SEQ ID NO 212  
<211> LENGTH: 31  
<212> TYPE: DNA  
<213> ORGANISM: Artificial Sequence  
<220> FEATURE:  
<223> OTHER INFORMATION: Description of Artificial Sequence: Synthetic  
oligonucleotide  
<220> FEATURE:  
<223> OTHER INFORMATION: Description of Combined DNA/RNA Molecule:  
Synthetic oligonucleotide  
  
<400> SEQUENCE: 212  
  
aaacgggcca gacuuuguug gauuugaaac c 31

<210> SEQ ID NO 213  
<211> LENGTH: 29  
<212> TYPE: DNA  
<213> ORGANISM: Artificial Sequence  
<220> FEATURE:  
<223> OTHER INFORMATION: Description of Artificial Sequence: Synthetic  
oligonucleotide  
<220> FEATURE:  
<223> OTHER INFORMATION: Description of Combined DNA/RNA Molecule:  
Synthetic oligonucleotide  
  
<400> SEQUENCE: 213  
  
uuucaaaaacc aacaaagucu guuccgutt 29

<210> SEQ ID NO 214  
<211> LENGTH: 31  
<212> TYPE: DNA  
<213> ORGANISM: Artificial Sequence  
<220> FEATURE:  
<223> OTHER INFORMATION: Description of Artificial Sequence: Synthetic  
oligonucleotide  
<220> FEATURE:  
<223> OTHER INFORMATION: Description of Combined DNA/RNA Molecule:  
Synthetic oligonucleotide  
  
<400> SEQUENCE: 214  
  
aaacgggcca gacuuuguug gauuugaaac c 31

<210> SEQ ID NO 215  
<211> LENGTH: 29  
<212> TYPE: DNA  
<213> ORGANISM: Artificial Sequence  
<220> FEATURE:  
<223> OTHER INFORMATION: Description of Artificial Sequence: Synthetic  
oligonucleotide  
<220> FEATURE:  
<223> OTHER INFORMATION: Description of Combined DNA/RNA Molecule:  
Synthetic oligonucleotide

-continued

---

```

<400> SEQUENCE: 215
uuucaaaucc aacaaagucu guuccgutt                29

<210> SEQ ID NO 216
<211> LENGTH: 31
<212> TYPE: DNA
<213> ORGANISM: Artificial Sequence
<220> FEATURE:
<223> OTHER INFORMATION: Description of Artificial Sequence: Synthetic
        oligonucleotide
<220> FEATURE:
<223> OTHER INFORMATION: Description of Combined DNA/RNA Molecule:
        Synthetic oligonucleotide

<400> SEQUENCE: 216
aaacgggcca gacuuuguug gauuugaaac c            31

<210> SEQ ID NO 217
<211> LENGTH: 29
<212> TYPE: DNA
<213> ORGANISM: Artificial Sequence
<220> FEATURE:
<223> OTHER INFORMATION: Description of Artificial Sequence: Synthetic
        oligonucleotide
<220> FEATURE:
<223> OTHER INFORMATION: Description of Combined DNA/RNA Molecule:
        Synthetic oligonucleotide

<400> SEQUENCE: 217
uuucaaaucc aacaaagucu guuccgttt                29

<210> SEQ ID NO 218
<211> LENGTH: 33
<212> TYPE: DNA
<213> ORGANISM: Artificial Sequence
<220> FEATURE:
<223> OTHER INFORMATION: Description of Artificial Sequence: Synthetic
        oligonucleotide
<220> FEATURE:
<223> OTHER INFORMATION: Description of Combined DNA/RNA Molecule:
        Synthetic oligonucleotide

<400> SEQUENCE: 218
ugaaacgggc cagacuuugu uggauuugaa acc          33

<210> SEQ ID NO 219
<211> LENGTH: 31
<212> TYPE: DNA
<213> ORGANISM: Artificial Sequence
<220> FEATURE:
<223> OTHER INFORMATION: Description of Artificial Sequence: Synthetic
        oligonucleotide
<220> FEATURE:
<223> OTHER INFORMATION: Description of Combined DNA/RNA Molecule:
        Synthetic oligonucleotide

<400> SEQUENCE: 219
uuucaaaucc aacaaagucu guuccgtttu g            31

```

---

**1-106.** (canceled)

**107.** An isolated double stranded nucleic acid (dsNA) comprising a first oligonucleotide strand having a 5' terminus and a 3' terminus and a second oligonucleotide strand having a 5' terminus and a 3' terminus, wherein:

said first strand is 31 to 60 nucleotide residues in length,  
 said second strand is 31 to 60 nucleotide residues in length;

said second strand anneals to said first strand,  
 said second strand comprises a 3' overhang of unmodified  
 and modified nucleotides,  
 said second strand is complementary to a sequence of a  
 target mRNA of a target gene; and  
 said second strand is sufficiently complementary to a target  
 RNA to reduce target gene expression when said double

- stranded nucleic acid is introduced into a mammalian cell.
- 108.** The isolated dsNA of claim **107**, wherein the overhang of the second strand is conjugated to a non-nucleic acid moiety.
- 109.** The isolated dsNA of claim **108**, wherein the non-nucleic acid moiety is a peptide or an organic compound.
- 110.** The isolated dsNA of claim **109**, wherein the organic compound is a dye.
- 111.** The isolated dsNA of claim **110**, wherein the organic compound is cholesterol.
- 112.** The isolated dsNA of claim **107**, in combination with a sugar
- 113.** The isolated dsNA of claim **108**, wherein the non-nucleic acid moiety increases cellular uptake.
- 114.** The isolated dsNA of claim **108**, wherein the non-nucleic acid moiety increase cellular targeting of the dsNA.
- 115.** The isolated dsNA of claim **108**, wherein the non-nucleic acid moiety increases stability of the dsNA.
- 116.** The isolated dsNA of claim **108**, wherein the non-nucleic acid moiety facilitates tracking of the dsNA.
- 117.** The isolated dsNA of claim **108**, wherein the non-nucleic acid moiety increases the binding affinity of the dsNA.
- 118.** The isolated dsNA of claim **108**, wherein the non-nucleic acid moiety decreases the immunogenicity of the dsNA.
- 119.** The isolated dsNA of claim **107**, wherein the modified nucleotide is a phosphorothioate-modified nucleotide residue (PS-NA).
- 120.** The isolated dsNA of claim **107**, wherein the modified nucleotide is a peptide nucleic acid (PNA).
- 121.** The isolated double stranded nucleic acid of claim **107**, wherein the modified nucleotide comprises a modified base and/or a modified sugar moiety.
- 122.** The isolated double stranded nucleic acid of claim **107**, wherein the modified nucleotide is selected from the group consisting of: dideoxyribonucleotides, acyclonucleotides 3'-deoxyadenosine (cordycepin), 3'-azido-3'-deoxythymidine (AZT), 2',3'-dideoxyinosine (ddI), 2',3'-dideoxy-3'-thiacytidine (3TC), 2',3'-didehydro-2',3'-dideoxythymidine (d4T), the monophosphate nucleotides of 3'-azido-3'-deoxythymidine (AZT), 2',3'-dideoxy-3'-thiacytidine (3TC) and 2',3'-didehydro-2',3'-dideoxythymidine (d4T).
- 123.** The isolated double stranded nucleic acid of claim **121**, wherein the modified sugar moiety is selected from the group consisting of 2'-O-methyl, 2'-methoxyethoxy, 2'-fluoro, 2'-allyl, 2'-O[2-(methylamino)-2-oxoethyl], 4'-thio, 4'-CH<sub>2</sub>-O-2'-bridge, 4'-(CH<sub>2</sub>)<sub>2</sub>-O-2'-bridge, 2'-LNA, 2'-amino and 2'-O—(N-methylcarbamate).
- 124.** The isolated double stranded nucleic acid of claim **107**, wherein at least one internucleoside linkage is modified.
- 125.** The isolated double stranded nucleic acid of claim **124**, wherein the internucleoside linkage modification is selected from the group consisting of: methylphosphonate, phosphorothioate, and phosphotriester modifications.
- 126.** The isolated double stranded nucleic acid of claim **107**, further comprising a fluorescein.
- 127.** The isolated double stranded nucleic acid of claim **107**, wherein the modified nucleotide comprises an LNA modification.
- 128.** The isolated dsNA of claim **107**, wherein the modified nucleotide is selected from the group consisting of 2'-O-methyl, 2'-methoxyethoxy, 2'-fluoro, 2'-allyl, 2'-O-[2-(methylamino)-2-oxoethyl], 4'-thio, 4'-CH<sub>2</sub>-O-2'-bridge, 4'-(CH<sub>2</sub>)<sub>2</sub>-O-2'-bridge, 2'-LNA, 2'-amino and 2'-O—(N-methylcarbamate).
- 129.** The isolated dsNA of claim **107**, wherein the modified nucleotide of said 3' overhang is a 2'-O-methyl ribonucleotide.
- 130.** The isolated dsNA of claim **107**, wherein all nucleotides of said 3' overhang are modified nucleotides.
- 131.** The isolated dsNA of claim **107**, wherein one or both of said first and second strands comprises a 5' phosphate.
- 132.** The isolated dsNA of claim **107**, wherein the 3' overhang is two nucleotides in length and wherein said modified nucleotide of said 3' overhang is a 2'-O-methyl modified ribonucleotide.
- 133.** The isolated dsNA of claim **107**, wherein the first strand has a nucleotide sequence that is at least 80%, 90%, 95% or 100% complementary to the second strand nucleotide sequence.
- 134.** The isolated dsNA of claim **107**, wherein a nucleotide of said second or first oligonucleotide strand is substituted with a modified nucleotide that directs the orientation of Dicer cleavage.
- 135.** The isolated dsNA of claim **107**, wherein the 3' terminus of said first strand and the 5' terminus of said second strand are joined by a chemical linker.
- 136.** The isolated dsNA of claim **107**, wherein the dsNA is a dicer substrate.
- 137.** The isolated dsNA of claim **107**, wherein the dsNA is a Dicer substrate that, upon endogenous Dicer processing, yields double-stranded nucleic acids of 19-23 nucleotides in length capable of reducing target gene expression in a mammalian cell.
- 138.** The isolated dsNA of claim **107** comprising a phosphate backbone modification selected from the group consisting of a phosphonate, a phosphorothioate and a phosphotriester.
- 139.** The isolated dsNA of claim **107**, wherein the dsNA reduces target gene expression in a mammalian cell in vitro by an amount (expressed by %) selected from the group consisting of at least 10%, at least 50% and at least 80-90%.
- 140.** The isolated dsNA of claim **107**, wherein the dsNA, when introduced into a mammalian cell, reduces target gene expression by at least 70% when transfected into said cell at a concentration selected from the group consisting of 1 nM or less, 200 pM or less, 100 pM or less, 50 pM or less, 20 pM or less and 10 pM or less.
- 141.** The isolated dsNA of claim **107**, wherein at least 50% of the ribonucleotide residues of said dsNA are unmodified ribonucleotides.
- 142.** The isolated dsNA of claim **107**, wherein at least 50% of the ribonucleotide residues of said second strand are unmodified ribonucleotides.
- 143.** The isolated dsNA of claim **107**, wherein the second oligonucleotide strand, starting from the nucleotide residue of said second strand that is complementary to the 5' terminal nucleotide residue of said first oligonucleotide strand and toward the 5' end of said second strand, comprises alternating modified and unmodified nucleotide residues.

**144.** The isolated dsNA of claim **107**, wherein the first strand is of a length selected from the group consisting of: 33 to 49 nucleotides, 35 to 49 nucleotides and 37 to 49 nucleotides.

**145.** The isolated dsNA of claim **107**, wherein the second strand possesses a 3' overhang of 1-4 nucleotides in length.

**146.** The isolated dsNA of claim **145**, wherein the 3' overhang is 1-3 nucleotides in length.

**147.** The isolated dsNA of claim **145**, wherein the 3' overhang is 1-2 nucleotides in length.

**148.** A method for reducing expression of a target gene in a cell, comprising: contacting a cell with an isolated double stranded NA (dsNA) as claimed in claim **107** in an amount effective to reduce expression of a target gene in a cell in comparison to a reference dsRNA.

**149.** A method for reducing expression of a target gene in an animal, comprising: treating an animal with an isolated double stranded NA (dsNA) as claimed in claim **107** in an amount effective to reduce expression of a target gene in a cell of the animal in comparison to a reference dsRNA.

**150.** The method of claim **149**, wherein the dsNA possesses enhanced pharmacokinetics when compared to an appropriate control DsiRNA.

**151.** The method of claim **149**, wherein the dsNA possesses enhanced pharmacodynamics when compared to an appropriate control DsiRNA.

**152.** The method of claim **149**, wherein the dsNA possesses reduced toxicity when compared to an appropriate control DsiRNA.

**153.** The method of claim **149**, wherein the dsNA possesses enhanced intracellular uptake when compared to an appropriate control DsiRNA.

**154.** A pharmaceutical composition for reducing expression of a target gene in a cell of a subject comprising the isolated double stranded NA (dsNA) of claim **107** in an amount effective to reduce expression of a target gene in a cell in comparison to a reference dsRNA and a pharmaceutically acceptable carrier.

**155.** A method of synthesizing the double stranded NA (dsNA) of claim **107**, comprising chemically or enzymatically synthesizing said dsNA.

**156.** A kit comprising the dsNA of claim **107** and instructions for its use.

**157.** An isolated double stranded nucleic acid (dsNA) comprising a first oligonucleotide strand having a 5' terminus and a 3' terminus and a second oligonucleotide strand having a 5' terminus and a 3' terminus, wherein: the first strand is 31 to 60 nucleotide residues in length, wherein starting from the first nucleotide (position 1) at the 5' terminus of the first strand, positions 1 to 23 of said first strand are ribonucleotides; said second strand is 31 to 60 nucleotide residues in length and comprises 23 consecutive ribonucleotides that base pair with the ribonucleotides of positions 1 to 23 of said first strand to form a duplex; the 5' terminus of said first strand and the 3' terminus of said second strand form a structure selected from the group consisting of a blunt end and a 1-4 nucleotide 3' overhang; the 3' terminus of said first strand and the 5' terminus of said second strand form a duplexed blunt end; at least one of positions 24 to the 3' terminal nucleotide residue of said first strand is a deoxyribonucleotide that base pairs with a deoxyribonucleotide of said second strand; and said second strand is sufficiently complementary to a target RNA along at least 19 ribonucleotides of said second strand length to reduce

target gene expression when said double stranded nucleic acid is introduced into a mammalian cell.

**158.** The isolated dsNA of claim **157**, wherein two or more nucleotide residues of positions 24 to the 3' terminal nucleotide residue of said first strand are deoxyribonucleotides that base pair with deoxyribonucleotides of said second strand.

**159.** The isolated dsNA of claim **157**, wherein four or more nucleotide residues of positions 24 to the 3' terminal nucleotide residue of said first strand are deoxyribonucleotides that base pair with deoxyribonucleotides of said second strand.

**160.** The isolated dsNA of claim **157**, wherein six or more nucleotide residues of positions 24 to the 3' terminal nucleotide residue of said first strand are deoxyribonucleotides that base pair with deoxyribonucleotides of said second strand.

**161.** The isolated dsNA of claim **157**, wherein eight or more nucleotide residues of positions 24 to the 3' terminal nucleotide residue of said first strand are deoxyribonucleotides that base pair with deoxyribonucleotides of said second strand.

**162.** The isolated dsNA of claim **157**, wherein ten or more nucleotide residues of positions 24 to the 3' terminal nucleotide residue of said first strand are deoxyribonucleotides that base pair with deoxyribonucleotides of said second strand.

**163.** The isolated dsNA of claim **157**, wherein twelve or more nucleotide residues of positions 24 to the 3' terminal nucleotide residue of said first strand are deoxyribonucleotides that base pair with deoxyribonucleotides of said second strand.

**164.** The isolated dsNA of claim **157**, wherein fourteen or more nucleotide residues of positions 24 to the 3' terminal nucleotide residue of said first strand are deoxyribonucleotides that base pair with deoxyribonucleotides of said second strand.

**165.** The isolated dsNA of claim **157**, wherein sixteen or more nucleotide residues of positions 24 to the 3' terminal nucleotide residue of said first strand are deoxyribonucleotides that base pair with deoxyribonucleotides of said second strand.

**166.** The isolated dsNA of claim **157**, wherein eighteen or more nucleotide residues of positions 24 to the 3' terminal nucleotide residue of said first strand are deoxyribonucleotides that base pair with deoxyribonucleotides of said second strand.

**167.** The isolated dsNA of claim **157**, wherein twenty or more nucleotide residues of positions 24 to the 3' terminal nucleotide residue of said first strand are deoxyribonucleotides that base pair with deoxyribonucleotides of said second strand.

**168.** The isolated dsNA of claim **158**, wherein the deoxyribonucleotides of said first strand that base pair with said deoxyribonucleotides of said second strand are consecutive deoxyribonucleotides.

**169.** The isolated dsNA of claim **157**, wherein two or more consecutive nucleotide residues of positions 24 to 27 of said first strand are deoxyribonucleotides that base pair with deoxyribonucleotides of said second strand.

**170.** The isolated dsNA of claim **157**, wherein each of positions 24 and 25 of said first strand is a deoxyribonucleotide that base pairs with a deoxyribonucleotide of said second strand.

**171.** The isolated dsNA of claim **157**, wherein each nucleotide residue of positions 24 to 27 of said first oligonucleotide strand is a deoxyribonucleotide that base pairs with a deoxyribonucleotide of said second strand.



**172.** The isolated dsNA of claim **157**, wherein each nucleotide residue of positions 24 to 29 of said first oligonucleotide strand is a deoxyribonucleotide that base pairs with a deoxyribonucleotide of said second strand.

**173.** The isolated dsNA of claim **157**, wherein each nucleotide residue of positions 24 to 31 of said first oligonucleotide strand is a deoxyribonucleotide that base pairs with a deoxyribonucleotide of said second strand.

**174.** The isolated dsNA of claim **157**, wherein positions 24 to the 3' terminal nucleotide residue of said first strand comprise between one and 25 deoxyribonucleotide residues, wherein each of said deoxyribonucleotide residues of said first strand base pairs with a deoxyribonucleotide of said second strand.

**175.** The isolated dsNA of claim **157**, wherein the deoxyribonucleotides of said second strand that base pair with said deoxyribonucleotides of said first strand are not complementary to said target RNA.

**176.** The isolated dsNA of claim **157**, wherein the second strand possesses a 3' overhang of 1-4 nucleotides in length.

**177.** The isolated dsNA of claim **176**, wherein the 3' overhang is 1-3 nucleotides in length.

**178.** The isolated dsNA of claim **176**, wherein the 3' overhang is 1-2 nucleotides in length.

**179.** The isolated dsNA of claim **176**, wherein the nucleotides of said 3' overhang comprise a modified nucleotide.

**180.** The isolated dsNA of claim **179**, wherein the modified nucleotide residue is selected from the group consisting of 2'-O-methyl, 2'-methoxyethoxy, 2'-fluoro, 2'-allyl, 2'-O-[2-(methylamino)-2-oxoethyl], 4'-thio, 4'-CH<sub>2</sub>-O-2'-bridge, 4'-(CH<sub>2</sub>)<sub>2</sub>-O-2'-bridge, 2'-LNA, 2'-amino and 2'-O-(N-methylcarbamate).

**181.** The isolated dsNA of claim **179**, wherein the modified nucleotide of said 3' overhang is a 2'-O-methyl ribonucleotide.

**182.** The isolated dsNA of claim **179**, wherein all nucleotides of said 3' overhang are modified nucleotides.

**183.** The isolated dsNA of claim **157**, wherein one or both of said first and second strands comprises a 5' phosphate.

**184.** The isolated dsNA of claim **179**, wherein the 3' overhang is two nucleotides in length and wherein said modified nucleotide of said 3' overhang is a 2'-O-methyl modified ribonucleotide.

**185.** The isolated dsNA of claim **176**, wherein the second strand, starting from the nucleotide residue of said second strand that is complementary to the 5' terminal nucleotide residue of said first oligonucleotide strand (position 1\*), comprises unmodified nucleotide residues at all positions from position 20\* to the 5' terminal residue of said second strand.

**186.** The isolated dsNA of claim **157**, wherein starting from the first nucleotide (position 1\*) at the 3' terminus of said first strand, position 1\*, 2\* and/or 3\* is a deoxyribonucleotide.

**187.** The isolated dsNA of claim **186**, wherein the first strand comprises a deoxyribonucleotide at position 1\* from the 3' terminus of said first strand.

**188.** The isolated dsNA of claim **186**, wherein the first strand comprises deoxyribonucleotides at positions 1\* and 2\* from the 3' terminus of said first strand.

**189.** The isolated dsNA of claim **157**, wherein the ultimate and penultimate residues of said 3' terminus of said first strand are deoxyribonucleotides and the ultimate and penultimate residues of said 5' terminus of said second strand are ribonucleotides.

**190.** The isolated dsNA of claim **157**, wherein a nucleotide of said second or first oligonucleotide strand is substituted with a modified nucleotide that directs the orientation of Dicer cleavage.

**191.** The isolated dsNA of claim **157**, wherein starting from the first nucleotide (position 1\*) at the 3' terminus of said second strand, positions 1\*, 2\*, and 3\* from the 3' terminus of said second strand are modified nucleotides.

**192.** The isolated dsNA of claim **157**, wherein the first strand has a nucleotide sequence that is at least 80%, 90%, 95% or 100% complementary to the second strand nucleotide sequence.

**193.** The isolated dsNA of claim **157**, wherein the 3' terminus of said first strand and the 5' terminus of said second strand are joined by a chemical linker.

**194.** The isolated dsNA of claim **157**, wherein the dsNA is a Dicer substrate.

**195.** The isolated dsNA of claim **157**, wherein the dsNA is a Dicer substrate that, upon endogenous Dicer processing, yields double-stranded nucleic acids of 19-23 nucleotides in length capable of reducing target gene expression in a mammalian cell.

**196.** The isolated dsNA of claim **157** comprising a phosphate backbone modification selected from the group consisting of a phosphonate, a phosphorothioate and a phosphotriester.

**197.** The isolated dsNA of claim **157**, wherein the dsNA reduces target gene expression in a mammalian cell in vitro by an amount (expressed by %) selected from the group consisting of at least 10%, at least 50% and at least 80-90%.

**198.** The isolated dsNA of claim **157**, wherein the dsNA, when introduced into a mammalian cell, reduces target gene expression in comparison to a reference dsRNA that does not possess a deoxyribonucleotide-deoxyribonucleotide base pair.

**199.** The isolated dsNA of claim **157**, wherein the dsNA, when introduced into a mammalian cell, reduces target gene expression by at least 70% when transfected into said cell at a concentration selected from the group consisting of 1 nM or less, 200 pM or less, 100 pM or less, 50 pM or less, 20 pM or less and 10 pM or less.

**200.** The isolated dsNA of claim **157**, wherein at least 50% of the ribonucleotide residues of said dsNA are unmodified ribonucleotides.

**201.** The isolated dsNA of claim **157**, wherein at least 50% of the ribonucleotide residues of said second strand are unmodified ribonucleotides.

**202.** The isolated dsNA of claim **157**, wherein the at least one of positions 24 to the 3' terminal nucleotide residue of said first strand that is a deoxyribonucleotide that base pairs with a deoxyribonucleotide of said second strand is an unmodified deoxyribonucleotide.

**203.** The isolated dsNA of claim **202**, wherein both said at least one of positions 24 to the 3' terminal nucleotide residue of said first strand that is a deoxyribonucleotide that base pairs with a deoxyribonucleotide of said second strand and said deoxyribonucleotide of said second strand are unmodified deoxyribonucleotides.

**204.** The isolated dsNA of claim **157**, wherein at least 50% of all deoxyribonucleotides of said dsNA are unmodified deoxyribonucleotides.

**205.** The isolated dsNA of claim **157**, wherein the second oligonucleotide strand, starting from the nucleotide residue of said second strand that is complementary to the 5' terminal

nucleotide residue of said first oligonucleotide strand and toward the 5' end of said second strand, comprises alternating modified and unmodified nucleotide residues.

**206.** The isolated dsNA of claim **157**, wherein at least one of positions 24 to the 3' terminal nucleotide residue of said first strand is a phosphorothioate-modified nucleotide (PS-NA) That base pairs with a deoxyribonucleotide of said second strand

**207.** The isolated dsNA of claim **157**, wherein the target RNA is KRAS.

**208.** A method for reducing expression of a target gene in a cell, comprising: contacting a cell with an isolated double stranded NA (dsNA) as claimed in claim **157** in an amount effective to reduce expression of a target gene in a cell in comparison to a reference dsRNA.

**209.** A method for reducing expression of a target gene in an animal, comprising: treating an animal with an isolated double stranded NA (dsNA) as claimed in claim **157** in an amount effective to reduce expression of a target gene in a cell of the animal in comparison to a reference dsRNA.

**210.** The method of claim **209**, wherein the dsNA possesses enhanced pharmacokinetics when compared to an appropriate control DsiRNA.

**211.** The method of claim **209**, wherein the dsNA possesses enhanced pharmacodynamics when compared to an appropriate control DsiRNA.

**212.** The method of claim **209**, wherein the dsNA possesses reduced toxicity when compared to an appropriate control DsiRNA.

**213.** The method of claim **209**, wherein the dsNA possesses enhanced intracellular uptake when compared to an appropriate control DsiRNA.

**214.** A pharmaceutical composition for reducing expression of a target gene in a cell of a subject comprising the isolated double stranded NA (dsNA) of claim **157** in an amount effective to reduce expression of a target gene in a cell in comparison to a reference dsRNA and a pharmaceutically acceptable carrier.

**215.** A method of synthesizing the double stranded NA (dsNA) of claim **157**, comprising chemically or enzymatically synthesizing said dsNA.

**216.** A kit comprising the dsNA of claim **157** and instructions for its use.

\* \* \* \* \*