



US 20100016948A1

(19) **United States**
(12) **Patent Application Publication**
Chobotov

(10) **Pub. No.: US 2010/0016948 A1**
(43) **Pub. Date: Jan. 21, 2010**

(54) **ENDOVASCULAR GRAFT**

(60) Provisional application No. 60/074,112, filed on Feb. 9, 1998.

(75) Inventor: **Michael V. Chobotov**, Santa Rosa, CA (US)

Publication Classification

Correspondence Address:
Hoffmann & Baron LLP
6900 Jericho Turnpike
Syosset, NY 11791 (US)

(51) **Int. Cl.**
A61F 2/06 (2006.01)

(52) **U.S. Cl.** **623/1.13; 623/1.3**

(73) Assignee: **TRIVASCULAR2, INC.**, Santa Rosa, CA (US)

(57) **ABSTRACT**

(21) Appl. No.: **12/566,793**

An endovascular graft, which is configured to conform to the morphology of a vessel to be treated, includes a tubular ePTFE structure; an inflatable ePTFE structure disposed over at least a portion of the ePTFE tubular structure; and an injection port in fluid communication with the inflatable ePTFE structure for inflation of the inflatable ePTFE structure with an inflation medium. The inflatable ePTFE structure may be longitudinally disposed over the tubular ePTFE structure. The ePTFE structure may be a bifurcated structure having first and second bifurcated tubular structures, where the inflatable ePTFE structure is disposed over at least a portion of the first and second bifurcated tubular structures.

(22) Filed: **Sep. 25, 2009**

Related U.S. Application Data

(63) Continuation of application No. 11/390,732, filed on Mar. 28, 2006, now Pat. No. 7,615,071, which is a continuation of application No. 10/132,754, filed on Apr. 24, 2002, now Pat. No. 7,081,129, which is a continuation of application No. 09/133,978, filed on Aug. 14, 1998, now Pat. No. 6,395,019.

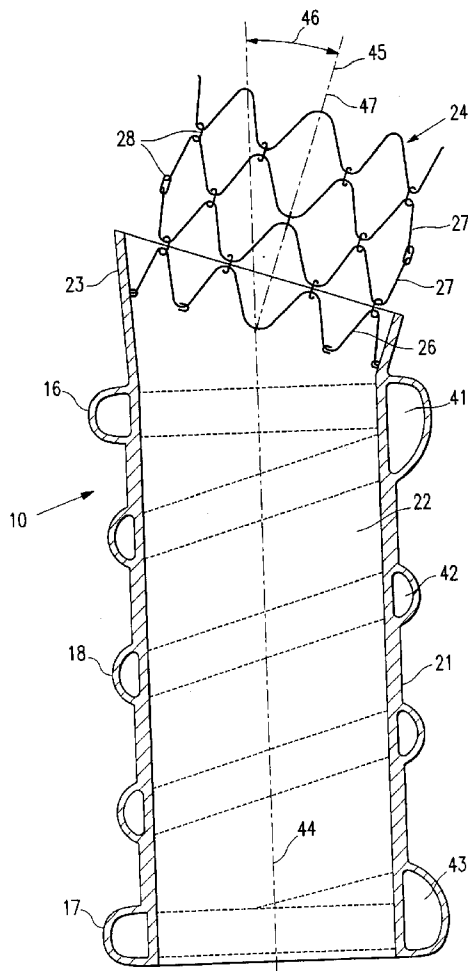

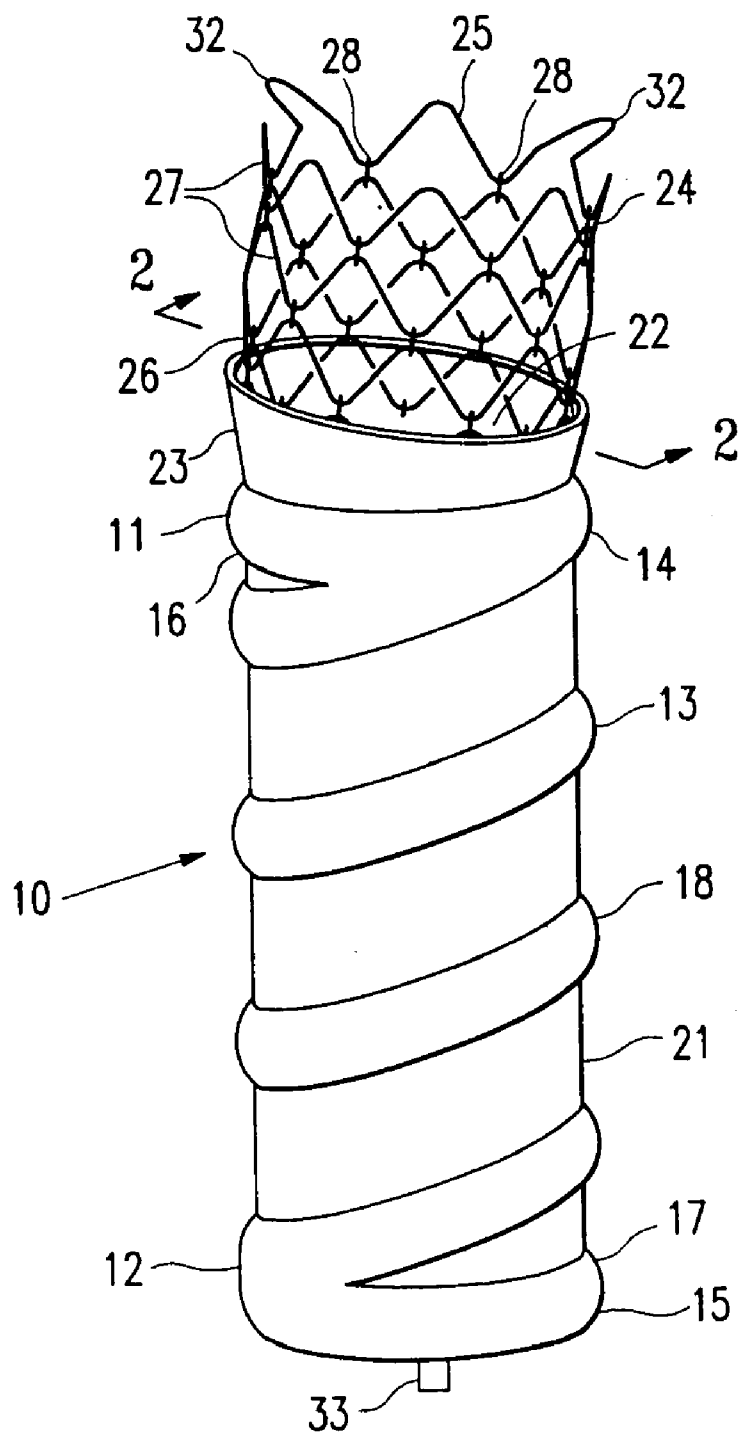

FIG. 1

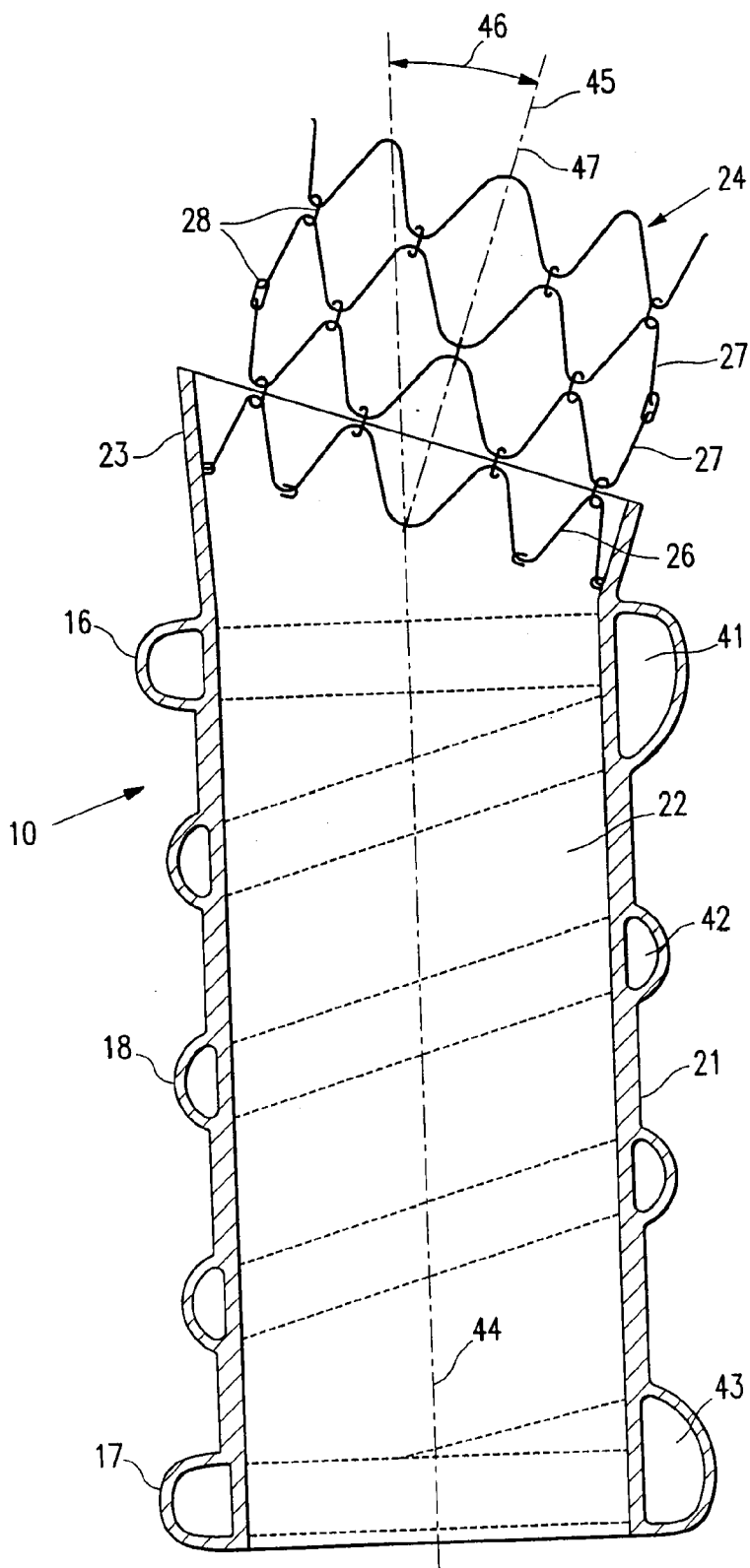

FIG. 2

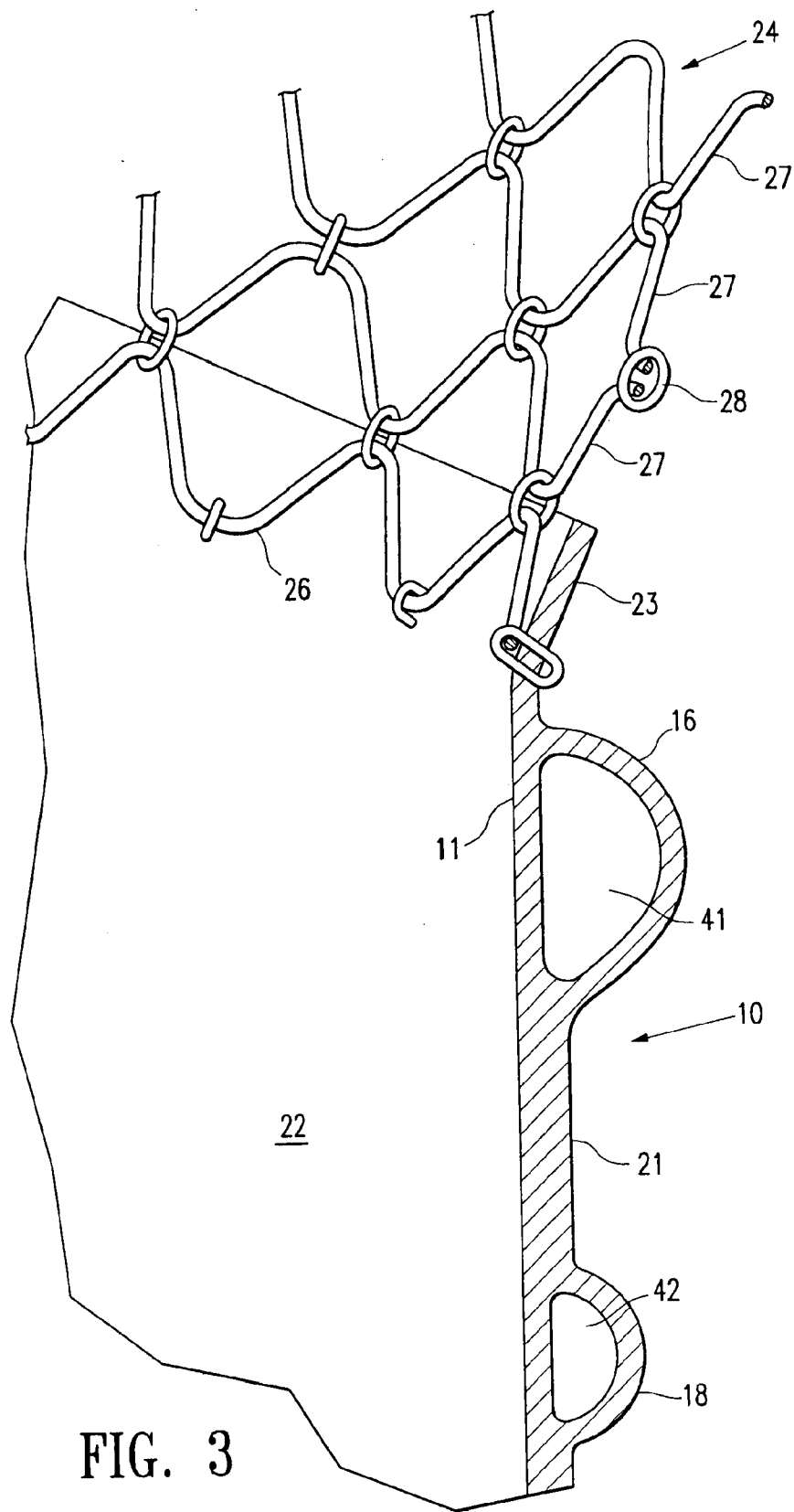

FIG. 3

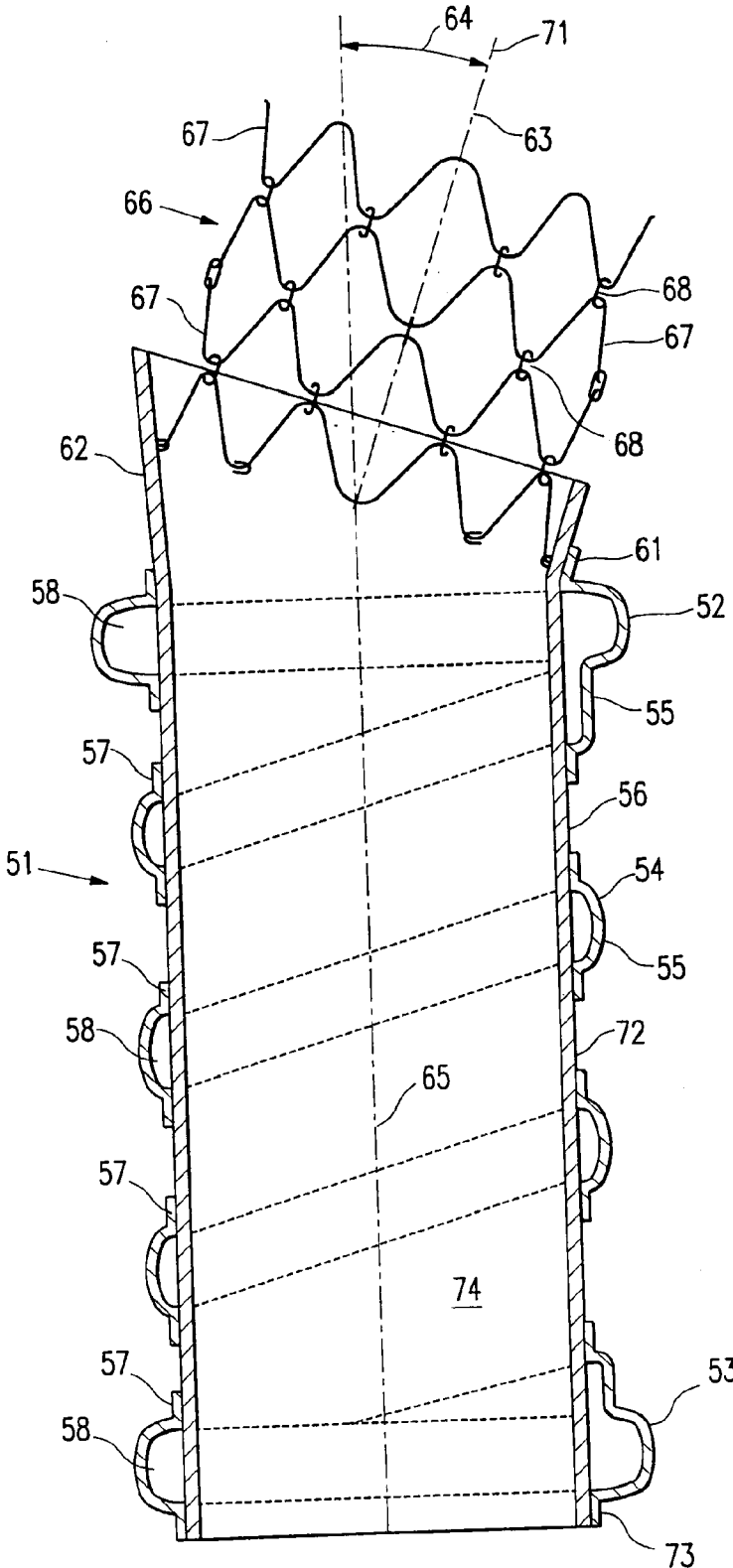

FIG. 4

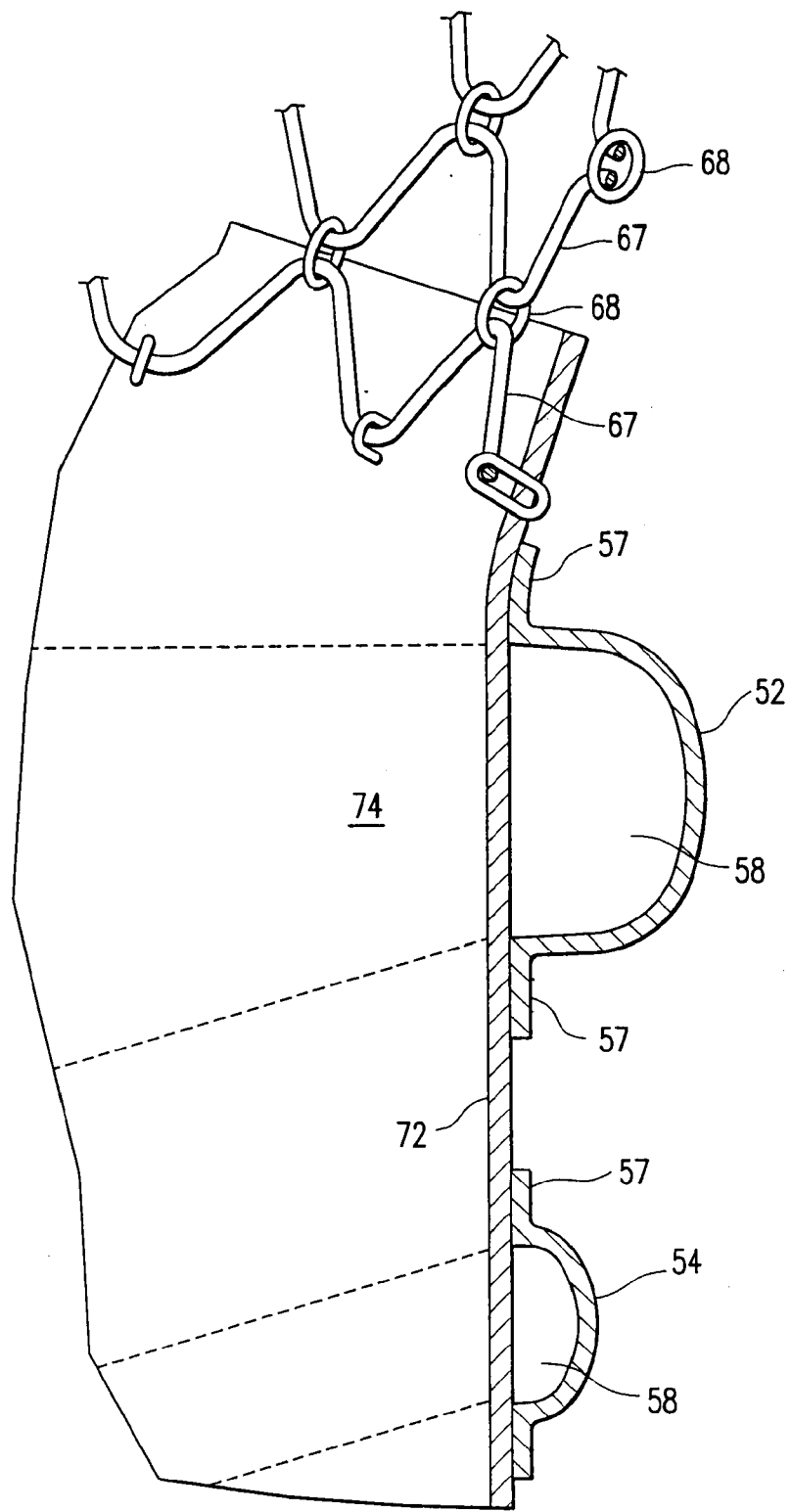

FIG. 5

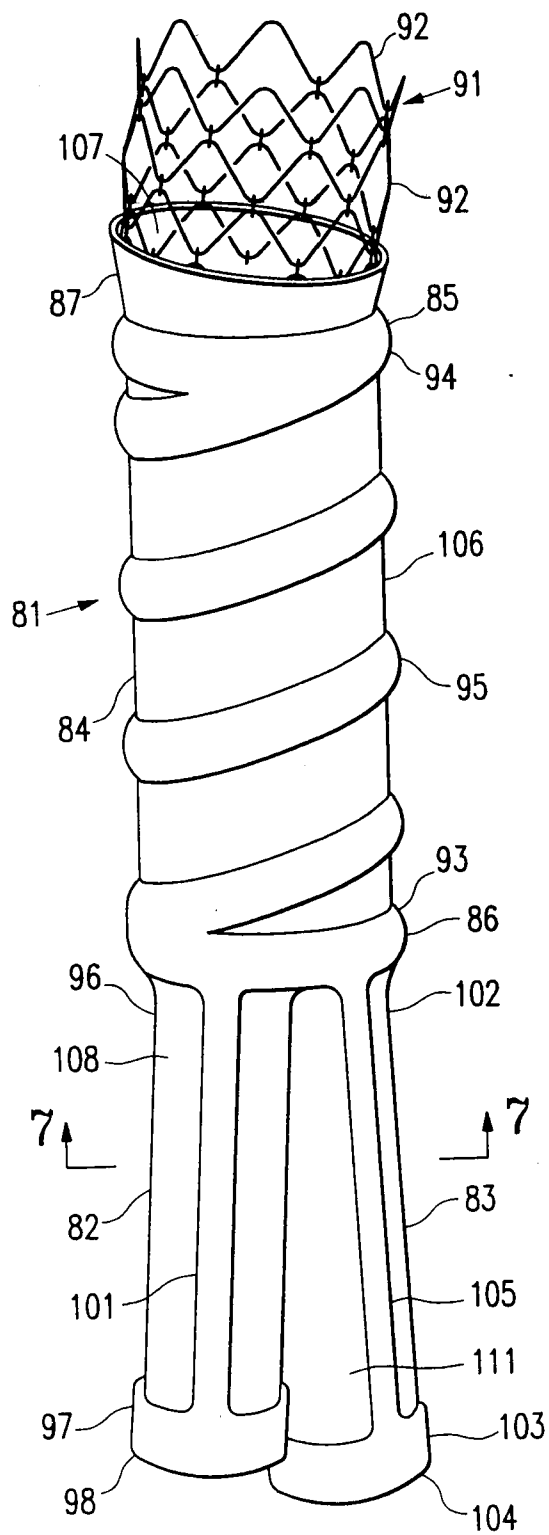

FIG. 6

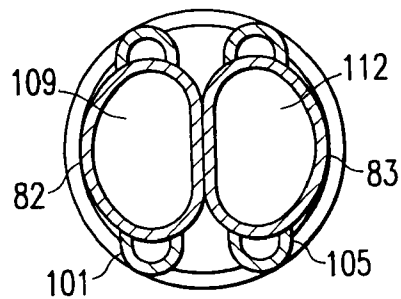

FIG. 7

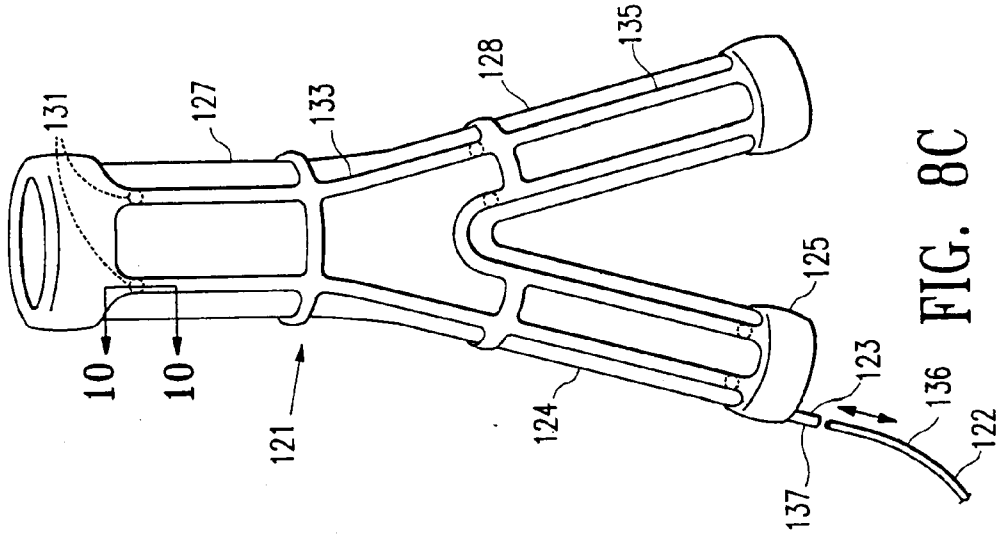

FIG. 8C

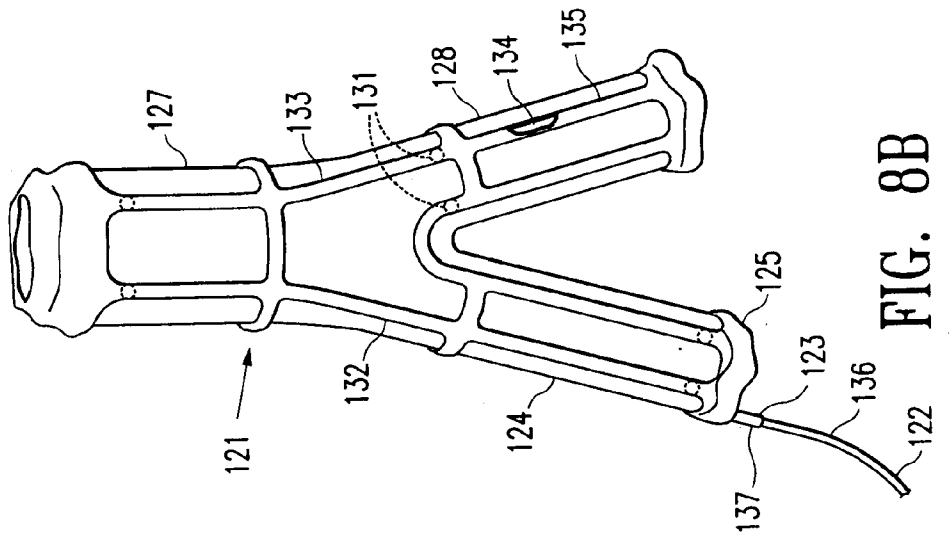

FIG. 8B

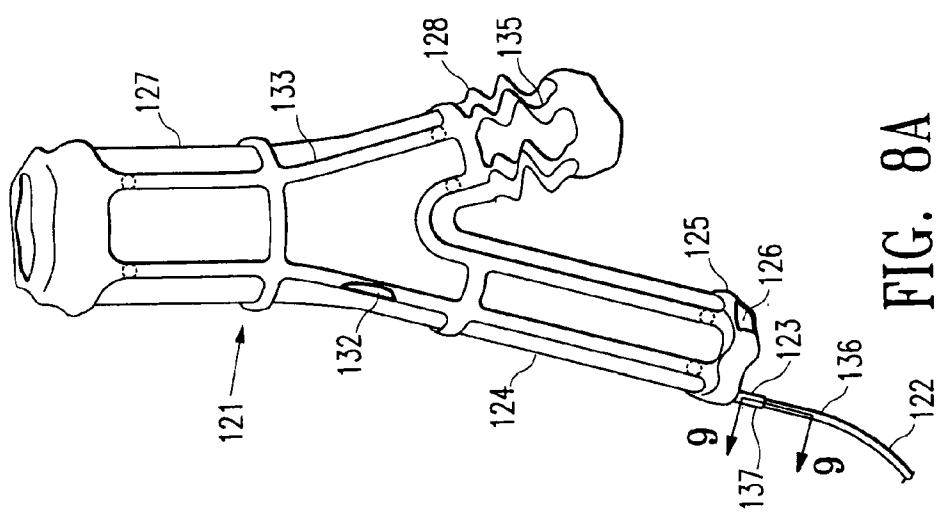

FIG. 8A

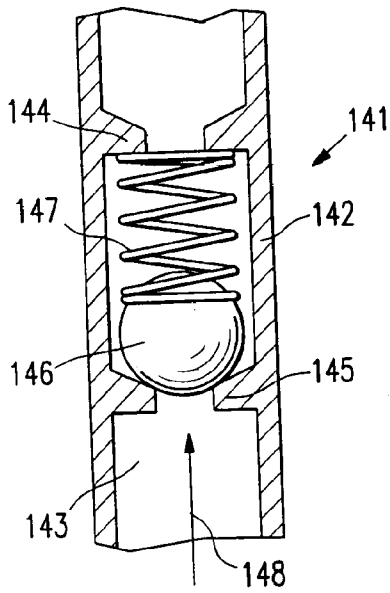

FIG. 9A

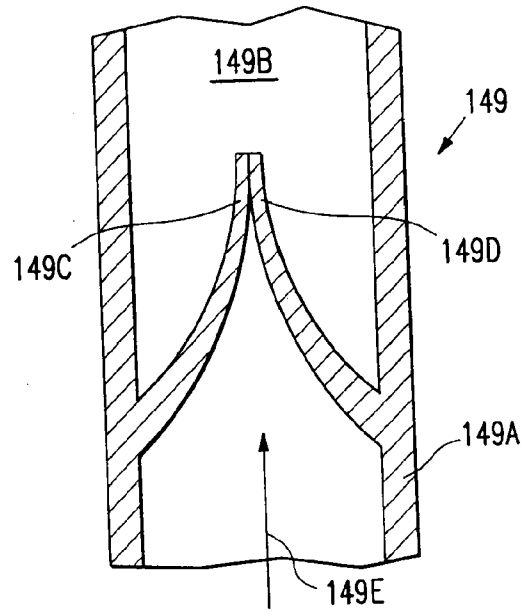

FIG. 9B

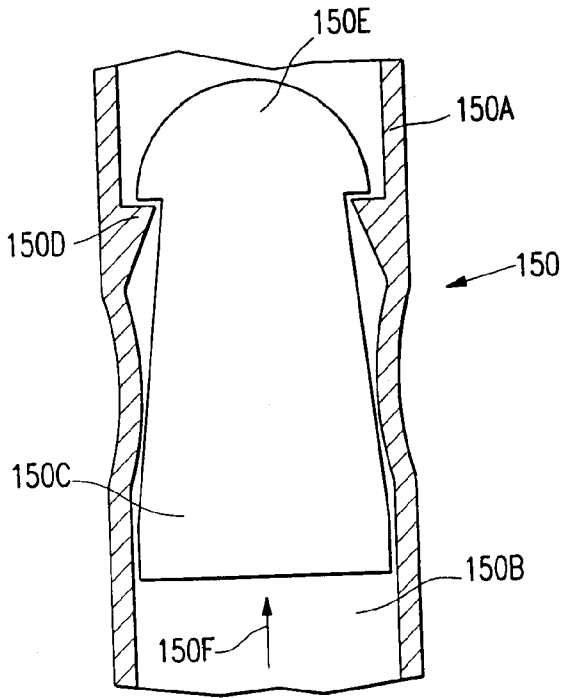

FIG. 9C

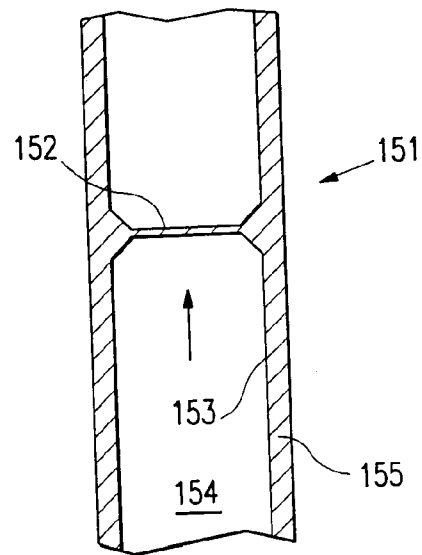

FIG. 10

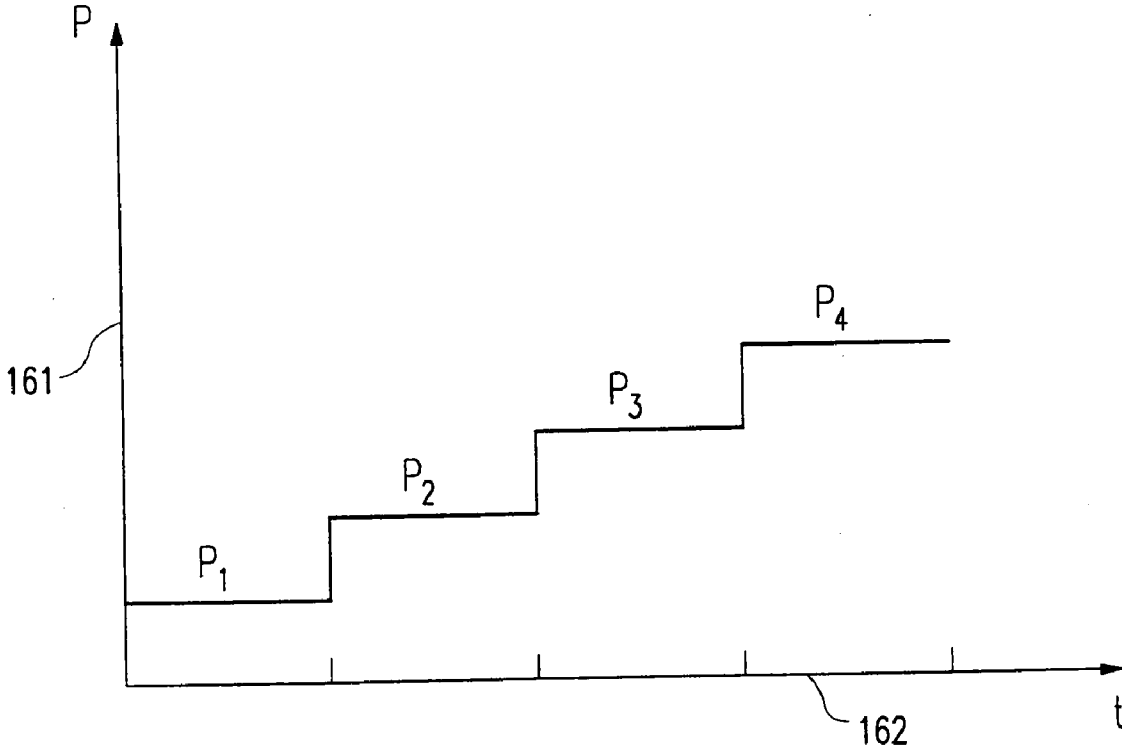

FIG. 11

ENDOVASCULAR GRAFT

CROSS-REFERENCE TO RELATED APPLICATIONS

[0001] This application is a continuation of U.S. application Ser. No. 11/390,732, filed Mar. 28, 2006, which is a continuation of U.S. application Ser. No. 10/132,754, filed Apr. 24, 2002, now U.S. Pat. No. 7,081,129, which is a continuation of U.S. application Ser. No. 09/133,978, filed Aug. 14, 1998, now U.S. Pat. No. 6,395,019, which claims the benefit of U.S. Provisional Application No. 60/074,112, filed Feb. 9, 1998, the contents of all of which are incorporated herein by reference.

BACKGROUND OF THE INVENTION

[0002] The present invention relates to a system and method for the treatment of disorders of the vasculature. More specifically, a system and method for treatment of abdominal aortic aneurysm and the like, which is a condition manifested by expansion and weakening of the aorta below the diaphragm. Such conditions require intervention due to the severity of the sequelae, which frequently is death. Prior methods of treating aortic aneurysm have consisted of invasive surgical methods with graft placement within the aorta as a reinforcing member of the artery. However, such a procedure requires a surgical cut down to access the vessel, which in turn can result in a catastrophic rupture of the aneurysm due to the decreased external pressure from the organs and tissues surrounding the aorta, which are moved during the procedure to gain access to the vessel. Accordingly, surgical procedures have a high mortality rate due to the possibility of the rupture discussed above in addition to other factors. Other factors can include poor physical condition of the patient due to blood loss, anuria, and low blood pressure associated with the aortic abdominal aneurysm. An example of a surgical procedure is described in a book entitled *Surgical Treatment of Aortic Aneurysms* by Denton A. Cooley, M.D., published in 1986 by W.B. Saunders Company.

[0003] Due to the inherent risks and complexities of surgical procedures, various attempts have been made in the development of alternative methods for deployment of grafts within aortic aneurysms. One such method is the non-invasive technique of percutaneous delivery by a catheter-based system. Such a method is described in Lawrence, Jr. et al. in "Percutaneous endovascular graft: experimental evaluation", *Radiology* (May 1987). Lawrence described therein the use of a Gianturco stent as disclosed in U.S. Pat. No. 4,580,568. The stent is used to position a Dacron fabric graft within the vessel. The Dacron graft is compressed within the catheter and then deployed within the vessel to be treated. A similar procedure has also been described by Mirich et al. in "Percutaneously placed endovascular grafts for aortic aneurysms: feasibility study," *Radiology* (March 1989). Mirich describes therein a self-expanding metallic structure covered by a nylon fabric, with said structure being anchored by barbs at the proximal and distal ends.

[0004] One of the primary deficiencies of the existing percutaneous devices and methods has been that the grafts and the delivery catheters used to deliver the grafts are relatively large in profile, often up to 24 French and greater, and stiff in bending. The large profile and bending stiffness makes delivery through the irregular and tortuous arteries of diseased vessels difficult and risky. In particular, the iliac arteries are

often too narrow or irregular for the passage of a percutaneous device. Because of this, non-invasive percutaneous graft delivery for treatment of aortic aneurysm is not available to many patients who would benefit from it.

[0005] Another contraindication for current percutaneous grafting methods and devices is a vessel treatment site with high neck angulation which precludes a proper fit between the graft and the vessel wall. An improper fit or seal between the graft and the vessel wall can result in leaks or areas of high stress imposed upon the diseased vessel which lead to reduced graft efficacy and possibly rupture of the aneurysm.

[0006] While the above methods have shown some promise with regard to treating abdominal aortic aneurysms with non-invasive methods, there remains a need for an endovascular graft system which can be deployed percutaneously in a small diameter flexible catheter system. In addition, there is a need for a graft which conforms more closely to the contours of an aortic aneurysm which are often quite irregular and angulated and vary from patient to patient. The present invention satisfies these and other needs.

SUMMARY OF THE INVENTION

[0007] The present invention is directed generally to an endovascular graft for vascular treatment and a method for manufacturing and using the graft. The graft generally has an inflatable tubular frame structure which can be configured to conform to the morphology of a patient's vessel to be treated. The frame structure has a proximal end and a distal end with an inflatable cuff disposed on at least one end and preferably both. The inflatable cuffs can be reduced in diameter and profile when deflated for introduction into a patient's vasculature by a catheter based delivery system or other suitable means. The inflatable cuffs provide a sufficiently rigid structure when inflated which supports the graft and seals the graft against the interior surface of the vessel in which it is being deployed. One or more elongated inflatable channels may also be disposed on the graft. Preferably, the elongated channel is disposed between and in fluid communication with a proximal and distal inflatable cuff. The channel provides the desired stiffness upon inflation, prevents kinking of the graft frame, and facilitates deployment of the graft within a patient's body passageway. The elongated inflatable channel can be in a longitudinal or linear configuration with respect to the graft, but is preferably shaped as a helix disposed about the graft. Other orientations such as interconnecting grids or rings may also be suitable for the elongated channels. The inflatable cuffs and the elongated channel contain fluid tight chambers which are generally in fluid communication with each other but which may also be separated by valves or rupture discs therein to selectively control the sequence of inflation or deployment. The fluid tight chambers are typically accessed by an injection port which is configured to accept a pressurized source of gas, fluid, particles, gel or combination thereof and which is in fluid particle, gel or combination thereof and which is in fluid communication with at least one of the fluid tight chambers. A fluid which sets, hardens or gels over time can also be used. The number of elongated channels can vary with the specific configuration of the graft as adapted to a given indication, but generally, the number of channels ranges from 1 to 25, preferably 2 to about 8.

[0008] A proximal neck portion may be secured to the proximal inflatable cuff. The proximal neck portion has a flexible tubular structure that has a diameter similar to the

proximal inflatable cuff. The proximal neck portion can be configured as a straight tubular section or can be tapered distally or proximally to an increased or decreased diameter. Preferably, the proximal neck portion is secured and sealed to the proximal inflatable cuff and tapers proximally to an increased diameter so as to engage the inside surface of a vessel wall which provides a sealing function in addition to that of the proximal inflatable cuff. Such a configuration also smoothes the transition for fluid flow from the vessel of a patient to the lumen or channel within the endovascular graft. The proximal neck portion has an inlet axis that preferably has an angular bias with respect to a longitudinal axis of the graft.

[0009] Preferably, the graft has a monolithic structure wherein the material that comprises the inflatable cuffs and channels extends between these elements in a thin flexible layer that defines a longitudinal lumen to confine a flow of blood or other fluid therethrough. Such a monolithic structure can be made from a variety of suitable polymers including PVC, polyurethane, polyethylene and fluoropolymers such as TFE, PTFE and ePTFE. Additional stiffness or reinforcement can be added to the graft by the addition of metal or plastic inserts or battens to the graft, which can also facilitate positioning and deployment of the graft prior to inflation of an inflatable portion of the graft.

[0010] In another embodiment, the graft has a thin flexible layer disposed over or between a proximal inflatable cuff, a distal inflatable cuff, and an elongated inflatable channel of the frame. The thin flexible layer is made of a material differing from the material of the cuffs or elongated channel. The barrier is shaped so as to form a tubular structure defining a longitudinal lumen or channel to confine a flow of blood therethrough. The flexible barrier may be made of a variety of suitable materials such as DACRON®, NYLON®, or fluoropolymers such as TEFLON® or the like.

[0011] An endovascular graft having features of the invention may be made in a tubular configuration of a flexible layer material such as Dacron, Nylon or fluoropolymers as discussed above. The inflatable cuffs and elongated channels are formed separately and bonded thereto. The inflatable cuffs and channels may also be made from the same layer material, i.e., Dacron, Teflon, or Nylon with a fluid impermeable membrane or bladder disposed within the cuff or channel so as to make it fluid tight. To limit permeability, the material in the regions of the cuffs and channels may also be treated with a coating or otherwise be processed by methods such as thermo-mechanical compaction.

[0012] In one embodiment of the invention, an expansion member is attached to the proximal end of the frame structure of the graft or to a proximal neck portion of the graft. Expansion members may also be attached to the distal end of the graft. Preferably, the expansion member is made of an expandable ring or linked expandable rings of pseudoelastic shape memory alloy which is self expanding and helps to mechanically anchor the proximal end of the graft to a body channel to prevent axial displacement of the graft once it is deployed. By having an expansion member which is distinct from the proximal cuff, the sealing function of the cuff, which requires supple conformation to the vessel wall without excessive radial force, can be separated from the anchoring function of the expansion member, which can require significant radial force. This allows each function to be optimized without compromising the function of the other. It also allows the anchoring function which can require more radial force on

the vessel wall to be located more proximal from the aneurysm than the cuff, and therefore be positioned in a healthier portion of the vessel which is better able to withstand the radial force required for the anchoring function. In addition, the cuff and expansion members can be separated spatially in a longitudinal direction with the graft in a collapsed state for delivery which allows for a lower more flexible profile for percutaneous delivery. Such a configuration makes a collapsed delivery profile of 12-16 French possible, preferably below 12 French.

[0013] The expandable ring or rings of the expansion member may be formed in a continuous loop having a serpentine or zig-zag pattern along a circumference of the loop. Any other similar configuration could be used that would allow radial expansion of the ring. The expansion member may be made of suitable high strength metals such as stainless steel, Nitinol or other shape memory alloys, or other suitable high strength composites or polymers. The expansion member may be made from high memory materials such as Nitinol or low memory materials such as stainless steel depending on the configuration of the endovascular graft, the morphology of the deployment site, and the mode of delivery and deployment of the graft.

[0014] The expansion member preferably has an inlet axis which forms an inlet axis angle in relation to a longitudinal axis of the graft. The angled inlet axis allows the graft to better conform to the morphology of a patient's vasculature in patients who have an angulated neck aneurysm morphology. The inlet axis angle can be from about 0 to about 90 degrees, preferably about 20 degrees to about 30 degrees. Some or all of the inlet axis angle can be achieved in a proximal neck portion of the graft, to which the expansion member may be attached. An expansion member or members may also be attached to the distal end of the graft.

[0015] In another embodiment of the invention, the graft may be bifurcated at the distal end of a main body portion of the graft and have at least two bifurcated portions with longitudinal lumens in fluid communication with a longitudinal lumen of the main body portion. The first bifurcated portion and second bifurcated portion can be formed from a structure similar to that of a main body portion with optional inflatable cuffs at either the proximal or distal end. One or more elongated channels can be disposed between the inflatable cuffs.

[0016] The size and angular orientation of the bifurcated portions can vary, however, they are generally configured to have an outer diameter that is compatible with the inner diameter of a patient's iliac arteries. The bifurcated portions can also be adapted to use in a patient's renal arteries or other suitable indication. The distal ends of the bifurcated portions may also have expansion members attached thereto in order to anchor or expand, or both anchor and expand said distal ends within the body passageway being treated. The expansion members for the distal ends of the bifurcated portions can have similar structure to the expansion member attached to the proximal end or proximal neck portion of the main body portion. The expansion members are preferably made from a shape memory material such as Nitinol.

[0017] In bifurcated embodiments of grafts having features of the invention which also have a biased proximal end which forms an inlet axis angle, the direction of the bias or angulation can be important with regard to achieving a proper fit between the graft and the morphology of the deployment site. Generally, the angular bias of the proximal end of the graft, proximal neck portion or proximal expansion member can be

in any direction. Preferably, the angular bias is in a direction normal to a plane defined by a longitudinal axis of the main body portion, the first bifurcated portion and the second bifurcated portion.

[0018] In another embodiment of the invention, rupture discs or other temporary closures are placed between fluid tight chambers of the inflatable cuffs and elongated channel or channels of the graft and form a seal between the chambers. The rupture discs may be burst or broken if sufficient force or pressure is exerted on one side of a disc or temporary closure. Once the graft is located at the site to be treated within a body passageway of a patient, a pressurized gas, fluid or gel may be injected by an inflation catheter into one of the fluid tight chambers of the graft through an injection port. Injection of a pressurized substance into an inflatable cuff will cause the cuff to take a generally annular shape, although the cuff can conform to the shape of the vessel within which it is deployed, and exert a sufficient radial force outward against the inner surface of the body passageway to be treated in order to provide the desired sealing function.

[0019] Multiple rupture discs can be disposed in various locations of the graft and also be configured to rupture at different pressures or burst thresholds to facilitate deployment of the graft within a body passageway. In a particular bifurcated embodiment of the invention, the proximal inflatable cuff of the main body portion may be positioned proximal of a junction between the branch of the abdominal aorta and the iliac arteries of a patient. As the proximal cuff is deployed by injection of an appropriate substance into an injection port in fluid communication with the fluid tight chamber thereof, it will expand radially and become axially and sealingly fixed proximal to the bifurcation of the aorta. A rupture disc is located between the fluid tight chamber of the proximal cuff and the elongated inflatable channels so that the proximal cuff may be substantially deployed before the rupture disc bursts and the elongated channels begin to fill with the injected substance. The elongated channels then fill and become sufficiently rigid and expand to create a longitudinal lumen therein. As pressure is increased within the fluid tight chamber, a rupture disc between the fluid tight chamber of the elongated channels and a fluid tight chamber of the optional distal inflatable cuff or distal manifold of the main body portion will burst and the distal inflatable cuff or manifold will deploy and become pressurized. One of the bifurcated portions of the graft may then be deployed as a rupture disc sealing its fluid tight chamber from the distal inflatable cuff or manifold of the main body portion of the graft bursts as the inflation pressure is increased. Finally, the second bifurcated portion of the graft deploys after a rupture disc sealing its fluid tight chamber from the main body portion bursts.

[0020] An inflation catheter which is attached to and in fluid communication with the fluid tight chambers of the graft via an injection port disposed thereon can be decoupled from the injection port after completion of inflation by elevating pressure above a predetermined level. The elevated pressure causes a break in a connection with the injection port by triggering a disconnect mechanism. Alternatively, the inflation catheter can be unscrewed from its connection. The injection port can include a check valve, seal or plug to close off the egress of inflation material once the inflation catheter has been decoupled. The injection port could also be glued or twisted to seal it off.

[0021] A graft having features of the invention may also be deployed by percutaneous delivery with a catheter based sys-

tem which has an inflatable balloon member disposed within expansion members of the graft in a collapsed state. The graft is percutaneously delivered to a desired site. Once the graft is axially positioned, the inflatable member of the balloon may be expanded and the expansion members forced radially against the interior surface of a body channel within which it is disposed. The expansion members may also be self expanding from a constrained configuration once the constraint is removed. After the graft has been positioned by the catheter system, the inflatable cuff or cuffs and elongated channel or channels of the graft are pressurized.

[0022] These and other advantages of the invention will become more apparent from the following detailed description of the invention when taken in conjunction with the accompanying exemplary drawings.

BRIEF DESCRIPTION OF THE DRAWINGS

[0023] FIG. 1 shows a perspective view of an endovascular graft having features of the invention.

[0024] FIG. 2 shows a longitudinal cross sectional view of an endovascular graft having a monolithic structure.

[0025] FIG. 3 shows an enlarged view of the longitudinal cross sectional view of the endovascular graft of FIG. 2.

[0026] FIG. 4 shows a longitudinal cross-sectional view of an endovascular graft having features of the invention.

[0027] FIG. 5 shows an enlarged view of a portion of the endovascular graft shown in FIG. 4.

[0028] FIG. 6 is a perspective view of a bifurcated endovascular graft having features of the present invention.

[0029] FIG. 7 is a transverse cross-sectional view of a bifurcated portion of an endovascular graft taken at 7-7 of FIG. 6.

[0030] FIGS. 8A-8C depict perspective views of a bifurcated endovascular graft having features of the present invention in various stages of deployment.

[0031] FIG. 9A is an enlarged longitudinal cross sectional view of the valve that could be used to maintain inflation of a fluid tight chamber in the endovascular graft taken at 9-9 of FIG. 8A.

[0032] FIG. 9B is an enlarged longitudinal cross sectional view of an alternative seal that could be used to maintain inflation of a fluid tight chamber in the endovascular graft taken at 9-9 of FIG. 8A.

[0033] FIG. 9C is an enlarged longitudinal cross sectional view of an alternative sealing plug that could be used to maintain inflation of fluid tight chamber in the endovascular graft taken at 9-9 of FIG. 8A.

[0034] FIG. 10 is an enlarged longitudinal cross sectional view of a rupture disc that could be used to control the inflation sequence of an inflatable endovascular graft taken at 10-10 of FIG. 8C.

[0035] FIG. 11 is a plot of inflation pressure of an inflatable endovascular graft with respect to time for an endovascular graft having features of the present invention including rupture discs which are configured to yield at various predetermined pressures.

DETAILED DESCRIPTION OF THE INVENTION

[0036] FIG. 1 shows a perspective view of an endovascular graft 10 having features of the present invention and having a proximal end 11 and a distal end 12. The graft is supported by an inflatable frame 13 which has a proximal end 14 and a distal end 15 and is shown in its deployed state. The inflatable frame structure 13 has a proximal inflatable cuff 16 at the

proximal end **14** and an optional distal inflatable cuff **17** at the distal end **15**. The inflatable cuffs **16** and **17** can be annular in shape when deployed, although the cuffs can conform to the shape of the vessel within which they are deployed, and can have an outside diameter or cross sectional dimension of about 10 to about 45 mm, preferably about 16 to about 28 mm. There is at least one elongated inflatable channel **18** disposed between the proximal inflatable cuff **16** and the distal inflatable cuff **17**. The inflatable frame **13** can be from about 5 to about 30 cm in length, preferably about 10 to about 20 cm in length. Disposed between the proximal inflatable cuff **16**, the distal inflatable cuff **17** and the elongated inflatable channel **18** is a thin flexible layer **21** that forms a longitudinal lumen **22** which can confine a flow of fluid therethrough. The thin flexible layer **21** may be made from the same material as the inflatable cuffs **16** and **17** and elongated channel **18** and be integral with the construction of those elements forming a monolithic structure. The thin flexible layer **21** and the materials used to form the frame structure **13** can have a wall thickness of about 0.1 to about 0.5 mm, preferably about 0.15 to about 0.25 mm. The inflatable frame **13** may be constructed from any suitable medical polymer or other material, including fluoropolymers, PVCs, polyurethanes, PET, ePTFE and the like. Preferably the inflatable frame **13** and thin flexible layer **21** are made from ePTFE. A proximal neck portion **23** is attached to the proximal end of the inflatable frame structure **13** and serves as an additional means to seal the graft against the inside of a body passageway, provides a means of biasing a proximal end of the graft **11**, and provides a smooth flow transition into longitudinal lumen **22**.

[0037] An expansion member **24** having a proximal end **25** and a distal end **26** has the distal end secured to the proximal end **14** of the frame **13**. The distal end **26** of the expansion member may also be secured to the proximal neck portion **23**. The expansion member **24** can be made from expandable rings **27** formed in a zig-zag pattern and connected by links **28**. The expansion member **24** is preferably a self-expanding member that expands to contact the inside wall of a body passage upon release from a constrained state. The expansion member **24** may be made from any suitable material that permits expansion from a constrained state, preferably a shape memory alloy such as Nitinol. The expansion member **24** may be configured to self expand from a constrained state or be configured to expand as a result of an outward radial force applied from within. Other materials suitable for construction of the expansion member **24** include stainless steel, MP35N alloy, shape memory alloys other than Nitinol, fiber composites and the like. The links **28** allow articulation of the expansion member **24** to traverse curvature of a patient's anatomy both during delivery and in situ. The expansion member **24** has a generally cylindrical shape but may also have outwardly directed protuberances **32** that are designed to engage the inside surface of a body passage. The expansion member **24** is generally cylindrical in shape when deployed, although the expansion member can conform to the shape of the vessel within which it is deployed, and can have a length of about 0.5 to about 5 cm, preferably about 1 to about 4 cm. The diameter of the expansion member **24** is typically similar to that of the inflatable cuffs **16** and **17**, and can be about 10 to about 35 mm, preferably about 16 to about 28 mm. The high strength material from which the expansion member **24** is made can have a cross sectional dimension of about 0.1 to about 1.5 mm, preferably about 0.25 to about 1 mm.

[0038] The graft **10** is generally deployed by inflation of the inflatable frame structure **13** with a pressurized material of solid particles, gas, fluid or gel which can be injected through an injection port **33**. The pressurized material may contain a contrast medium which facilitates imaging of the device while being deployed within a patient's body. For example, radiopaque materials such as bismuth, barium, gold, platinum, tantalum or the like may be used in particulate or powder form to facilitate visualization of the graft under fluoroscopy. Fixed radiopaque markers may also be attached or integrally molded into the graft for the same purpose, and may be made from the same radiopaque materials discussed above.

[0039] FIG. 2 shows a longitudinal cross sectional view of the endovascular graft shown in FIG. 1. Within the proximal inflatable cuff **16** is a fluid tight chamber **41** which is in fluid communication with a fluid tight chamber **42** of the elongated inflatable channel **18**. The fluid tight chamber **42** of the elongated inflatable channel is in fluid communication with a fluid tight chamber **43** within the optional distal inflatable cuff **17**. A longitudinal axis **44** of the graft **10** is shown in addition to a proximal inlet axis **45** which forms an inlet axis angle **46** with the longitudinal axis. The angled inlet axis **45** is generally created by the proximal neck portion **23** and provides the graft with a profile which can conform to the morphology of a patient's vasculature. The expansion member **24** has a longitudinal axis **47** which is generally coextensive with the proximal inlet axis **45**, but can further bend to conform to local anatomy including neck angulation of a diseased vessel.

[0040] FIG. 3 shows an enlarged view of the longitudinal cross sectional view of a portion of the proximal end **11** of the graft **10** shown in FIG. 2. A more detailed view of the fluid tight chamber **41** of the proximal inflatable cuff **16** can be seen as well as a more detailed view of the attachment of the distal end **26** of the expansion member **24** to the proximal neck portion **23**. The thin flexible layer **21** can be seen disposed between the proximal inflatable cuff **16** and the elongated inflatable channel **18**. The expandable rings **27** of the expansion member **24** are connected by links **28** which can be made from the same material as the expansion member or any other suitable material such as a biocompatible fiber or a metal such as stainless steel or Nitinol.

[0041] FIG. 4 is a transverse cross-sectional view of an embodiment of an endovascular graft **51**, having features of the invention. The proximal inflatable cuff **52**, distal inflatable cuff **53**, and elongated inflatable channel **54** are formed by sealingly bonding strips of material **55** over a tubular structure **56**. The strips **55** are bonded at the edges **57** so as to form fluid tight chambers **58** therein. If the material of the strips **55** which have been bonded to the tubular structure **56** are of a permeable character, an additional material may be used to coat the inside of the fluid tight chambers in order to make them impermeable to fluids. Alternatively, the material of the strips **55** and the material of the elongated tubular member **56** adjacent thereto may be made impermeable by undergoing further thermal, mechanical, or chemical processing. Preferably, thermo-mechanical compaction would be used to render the fluid tight chambers **58** impermeable to fluids which would be suitable for inflating the graft **51**.

[0042] The proximal end **61** of the graft **51** has a proximal neck portion **62** which has an inlet axis **63** which forms an inlet axis angle **64** with a longitudinal axis **65** of the graft. The inlet axis angle **64** allows the graft **51** to better conform to morphology of a patient's vascular channels. An expansion

member **66** is also located at the proximal end **61** of the graft **51** and is formed of expandable rings **67** held together by links **68**. The expansion member **66** has a longitudinal axis **71** which can coincide with the inlet axis **63** of the proximal neck portion **62**. The graft **51** has a thin flexible layer **72** which extends from the distal end **73** of the graft **51**, to the proximal end of the graft **61**, including the proximal neck portion **62**. The thin flexible layer **72** forms a longitudinal lumen or channel **74** upon deployment of the graft, which confines a flow of blood or other bodily fluid therethrough.

[0043] FIG. 5 is an enlarged view of the longitudinal cross-sectional view of the endovascular graft of FIG. 4. A more detailed view of the fluid tight chamber **58** of the proximal inflatable cuff and elongated inflatable channel can be seen. The edges of the strips **57** which form the proximal inflatable cuff **52** and the elongated inflatable channel **54** are bonded at the edges by any suitable technique such as the use of adhesives, solvents, or heat. Suitable adhesives would include epoxies and cyanoacrylates or the like. Materials suitable for use as the thin flexible layer **72** or the strips **55** includes Dacron, Nylon, Teflon, and also such materials as PVC, polyethylene, polyurethane and ePTFE.

[0044] FIGS. 6 and 7 depict an endovascular graft **81** having features of the invention which has a first bifurcated portion **82** and a second bifurcated portion **83**. A main body portion **84** of the graft **81** has a proximal end **85** and a distal end **86** with a proximal neck portion **87** disposed at the proximal end as well as an expansion member **91** which can be formed of expandable rings **92** of a suitable material which have been linked together. At the distal end **86** of the main body portion **84** there is an optional distal inflatable cuff **93** which is connected fluidly to a proximal inflatable cuff **94** by an elongated inflatable channel **95**. The distal inflatable cuff **93** may optionally be replaced by a manifold or other suitable structure for fluid connection between the elongated inflatable channel **95** and the first bifurcated portion **82** or the second bifurcated portion **83**.

[0045] The first bifurcated portion **82** has a proximal end **96** and a distal end **97** with an optional distal inflatable cuff **98** located at the distal end. The distal end of the first bifurcated portion **97** may have an expansion member in conjunction with or in place of the distal inflatable cuff **98**. The proximal end **96** of the first bifurcated portion **82** is attached to the distal end **86** of the main body portion **84** of the graft **81**. The first bifurcated portion **82** has an optional inflatable elongated channel **101** which fluidly connects the distal inflatable cuff **98** of the first bifurcated portion **82** with the distal inflatable cuff **93** of the main body portion **84**. The inflatable elongated channel **101** also provides support for first bifurcated portion **82**.

[0046] The second bifurcated portion **83** generally has a structure similar to that of the first bifurcated portion **82**, with a proximal end **102** and a distal end **103**. The distal end **103** has an optional distal inflatable cuff **104**. The proximal end **102** of the second bifurcated portion **83** is connected to the distal end **86** of the main body portion **84** of the graft **81**. The distal end of the second bifurcated portion **103** may have an expansion member in conjunction with or in place of the distal inflatable cuff **104**. The second bifurcated portion **83** has an optional inflatable elongated channel **105** which fluidly connects the distal inflatable cuff **104** of the second bifurcated portion **83** with the distal inflatable cuff **93** of the main body portion **84**. The inflatable elongated channel **105** also provides support for the second bifurcated portion **83**.

The inflatable elongated channel of the first bifurcated portion **101** and inflatable elongated channel of the second bifurcated portion **105** may have a linear configuration as shown, a helical configuration similar to the main body portion **84**, or any other suitable configuration. Disposed between the proximal inflatable cuff **94**, distal inflatable cuff **93** and elongated inflatable channel **95** of the main body portion **84** of the graft **81** is a thin flexible layer **106** which forms a longitudinal lumen **107** to confine the flow of blood or other bodily fluid therethrough. Disposed between the distal inflatable cuff **98** and the elongated inflatable channel **101** of the first bifurcated portion **82** and the distal inflatable cuff **93** of the main body portion **84** is a first thin flexible layer **108** which forms a longitudinal lumen **109** which is in fluid communication with the longitudinal lumen **107** of the main body portion **84**. The second bifurcated portion may also be formed separate of a main body portion and be joined to the main body portion after percutaneous delivery thereof by docking methods. The first and second bifurcated portions **82** and **83** are generally cylindrical in shape when deployed, although they can conform to the shape of a vessel within which they are deployed, and can have a length from about 1 to about 10 cm. The outside diameter of the distal ends of the first and second bifurcated portions **82** and **83** can be from about 2 to about 30 mm, preferably about 5 to about 20 mm.

[0047] A second thin flexible layer **111** is disposed between the distal inflatable cuff **104** and elongated inflatable channel **105** of the second bifurcated portion **83** and the distal inflatable cuff **93** of the main body portion **84**. The second thin flexible layer **111** forms a longitudinal lumen **112** which is in fluid communication with the longitudinal lumen **107** of the main body portion **84**. The thin flexible layer of the first bifurcated portion surrounds the elongated lumen of the first bifurcated portion. The thin flexible layer of the second bifurcated portion surrounds the elongated lumen of the second bifurcated portion.

[0048] FIGS. 8A-8C depict an embodiment of an endovascular graft **121** having features of the invention in various stages of deployment. In FIG. 8A, an inflation catheter **122** is connected to an injection port **123** in a first bifurcated portion **124** of the endovascular graft **121**. The injection port **123** is connected to a distal inflatable cuff **125** of the first bifurcated portion **124** and is in fluid communication with a fluid tight chamber **126** therein. The first bifurcated portion **124** and a main body portion **127** have been substantially inflated in FIG. 8A, however, a second bifurcated portion **128** has been prevented from deployment by rupture discs **131** which have been disposed within fluid tight chambers **132** of the elongated inflatable channels **133** of the main body portion **127** which are connected to fluid tight chambers **134** of elongated inflatable channels **135** of the second bifurcated portion **128**. In FIG. 8B, the second bifurcated portion **128** has been substantially deployed subsequent to a rupture or bursting of the rupture discs **131** disposed within the fluid tight chambers **132** and **134** of the elongated inflatable channels **133** and **135** which permitted the flow of a pressurized substance therein. FIG. 8C shows the endovascular graft fully deployed and illustrates detachment of a distal end **136** of the inflation catheter **122** from the injection port **123** which is carried out by increasing the pressure within the inflation catheter until a disconnect mechanism **137** is triggered.

[0049] FIG. 9A illustrates a longitudinal cross-sectional view taken at 9-9 of FIG. 8A. The one-way inflation valve **141** has an outer wall **142**, an inner lumen **143**, an annular spring

stop 144, an annular ball seal 145, a sealing body 146 and a sealing spring 147. The configuration depicted in FIG. 9A allows for the ingress of an inflation medium in the direction of the arrow 148 while preventing an egress of same once pressure is removed.

[0050] FIG. 9B illustrates an alternative one way valve. The one-way inflation valve 149 has an outer wall 149A, an inner lumen 149B, a first reed valve 149C, and a second reed valve 149D which is fluidly sealed with the first reed valve in a relaxed state. The configuration depicted in FIG. 9B allows for the ingress of an inflation medium in the direction of the arrow 149E while preventing an egress of same once pressure is removed.

[0051] FIG. 9C illustrates an alternative seal 150. The seal has an outer wall 150A, an inner lumen 150B, a plug 150C and a sealing surface 150D. The plug 150C has a sealing head 150E which sealingly engages the sealing surface 150D by irreversible deployment by application of force to the plug in the direction of the arrow 150F.

[0052] FIG. 10 depicts a longitudinal cross-sectional view of a rupture disc 151 taken at 10-10 of FIG. 8C. The rupture disc 151 has a wall member 152 which is sealingly secured to the inside surface 153 of a fluid tight chamber 154. The wall member 152 is configured to fail under pressure prior to the failure of the surrounding wall 155 of the fluid tight chamber 154 under pressure. The rupture disc 151 allows for deployment and inflation of fluid tight chambers other than those which have been sealed by the rupture disc. Once sufficient force or pressure is exerted against the wall 152 of the rupture disc to cause failure, the rupture disc 151 will burst and permit the ingress of an inflation medium and deployment of a portion of an inflatable graft, previously sealed by the rupture disc.

[0053] FIG. 11 depicts a graphical representation of inflation pressure 161 versus the time 162 at an injection port of an inflatable graft as depicted in FIGS. 8A-8C during the deployment process. P_1 represents the inflation pressure at the injection port prior to the rupturing of any rupture discs in the endovascular graft. P_2 represents the pressure required to cause failure or bursting of the weakest rupture disc in the endovascular graft after which a portion of the endovascular graft previously sealed by the weakest rupture disc is inflated and deployed. The pressure then increases over time to P_3 which is the pressure level required to cause failure or bursting of a second rupture disc. P_4 is the pressure level required for triggering a disconnect mechanism at the distal end of the inflation catheter.

[0054] While particular forms of the invention have been illustrated and described, it will be apparent that various modifications can be made without departing from the spirit and scope of the invention. Accordingly, it is not intended that the invention be limited, except as by the appended claims.

What is claimed is:

1. An endovascular device comprising:
 - a polymeric tube having opposed first and second open ends;
 - an inflatable structure integral with or permanently secured to at least a portion of said polymeric tube; and
 - a non-inflatable expansion member disposed at one of said first and second opposed open ends;
 wherein the inflatable structure is inflatable with an inflation fluid to provide an inflated state such that the inflated state conforms to the shape of a bodily lumen.

2. The device of claim 1, wherein the inflatable structure in the inflated state seals a bodily lumen from blood flow.

3. The device of claim 1, wherein the inflated state conforms to a morphology of a deployment site of a bodily lumen.

4. The device of claim 1, wherein the inflatable structure is a polymeric structure.

5. The device of claim 1, wherein the polymeric tube comprises a polymeric material selected from the group consisting of polyvinylchloride (PVC), polyurethane, polyethylene and polyethylene terephthalate (PET).

6. The device of claim 1, wherein the polymeric tube comprises a fluoropolymer.

7. The device of claim 6, wherein the fluoropolymer comprises polytetrafluoroethylene (PTFE) or expanded polytetrafluoroethylene (ePTFE).

8. The device of claim 1, wherein the inflatable structure comprises a polymeric material selected from the group consisting of polyvinylchloride (PVC), polyurethane and polyethylene.

9. The device of claim 1, wherein the inflatable structure comprises a fluoropolymer.

10. The device of claim 9, wherein the fluoropolymer comprises polytetrafluoroethylene (PTFE) or expanded polytetrafluoroethylene (ePTFE).

11. The device of claim 1, wherein the polymeric tube further comprises a reinforcement member.

12. The device of claim 11, wherein the reinforcement member is metallic.

13. The device of claim 1, wherein the inflatable structure comprises a cuff.

14. The device of claim 13, wherein the cuff is annularly disposed at the first open end of the second open end.

15. The device of claim 1, wherein the inflatable structure comprises a first cuff annularly disposed at the first open end and a second cuff annularly disposed at the second open end.

16. An endovascular system, comprising
 - a polymeric tube having opposed open ends;
 - an inflatable structure disposed over at least a portion of said polymeric tube;
 - a non-inflatable expansion member disposed at one of said opposed open ends; and
 - an inflation fluid for inflating the inflatable structure; wherein the inflatable structure is inflatable with the inflation fluid to provide an inflated state such that the inflated state conforms to the shape of a bodily lumen.

17. The system of claim 16, wherein the inflated state conforms to a morphology of a deployment site of a bodily lumen.

18. The system of claim 16, wherein the inflation fluid is a gel.

19. The system of claim 18, wherein the gel hardens over time when disposed within inflatable structure.

20. The system of claim 16, further comprising a catheter for percutaneous delivery within a bodily lumen.

21. The system of claim 20, wherein the catheter further comprises an inflation balloon member.

22. The system of claim 16, wherein the polymeric tube further comprises a reinforcement member.

23. The system of claim 22, wherein the reinforcement member is metallic.

24. The system of claim 16, wherein the inflatable structure comprises a cuff.

25. The system of claim **24**, wherein the cuff is annularly disposed at one of said open ends.

26. The system of claim **16**, wherein the inflatable structure comprises a first cuff annularly disposed at one of said open ends and a second cuff annularly disposed at the other of said second open ends.

27. An implantable device, comprising:

a frame structure of biocompatible material having first and second opposed open ends;

an inflatable cuff disposed at the first open end;

a non-inflatable expansion member disposed at one of said first and second opposed open ends; and

a fluid for inflating the inflatable cuff.

28. The device of claim **27**, wherein the inflatable cuff is inflatable with the inflation fluid to provide an inflated state such that the inflated state conforms to a shape of a bodily lumen.

29. The device of claim **27**, wherein the inflatable cuff is inflatable with the inflation fluid to provide an inflated state such that the inflated state conforms to a morphology of a deployment site of the bodily lumen.

30. The device of claim **27**, wherein the fluid is a gel.

31. The device of claim **31**, wherein the gel hardens over time when disposed within inflatable cuff.

32. The device of claim **31**, wherein the gel includes a contrast medium.

33. The device of claim **32**, wherein the contrast medium includes a radiopaque material.

34. The device of claim **27**, wherein the inflatable cuff has an annular shape.

35. The device of claim **15**, wherein the frame structure of biocompatible material comprises a polymeric material selected from the group consisting of polyvinylchloride (PVC), polyurethane, polyethylene, polyethylene terephthalate (PET) and fluoropolymer.

36. The device of claim **35**, wherein the polymeric material is polyethylene terephthalate (PET).

37. The device of claim **27**, wherein the inflatable cuff comprises a polymeric material selected from the group consisting of polyvinylchloride (PVC), polyurethane, polyethylene, polyethylene terephthalate (PET) and fluoropolymer.

38. The device of claim **37**, wherein the polymeric material is polyethylene terephthalate (PET).

* * * * *