

PB88-910406

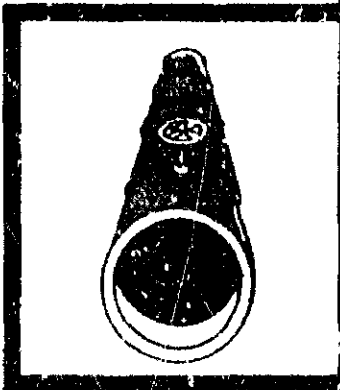
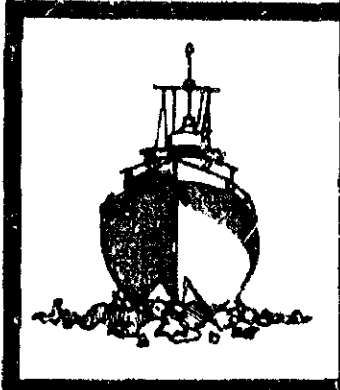
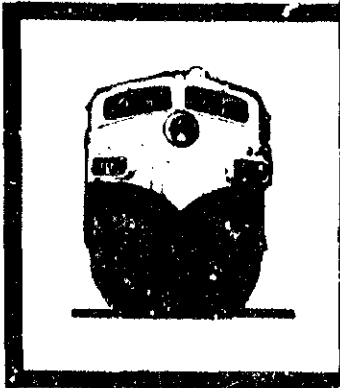
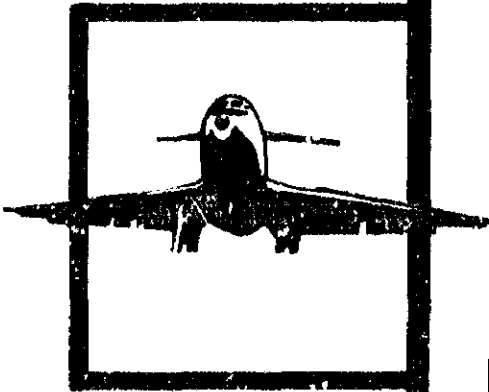

NATIONAL TRANSPORTATION SAFETY BOARD

WASHINGTON, D.C. 20594

AIRCRAFT ACCIDENT REPORT

**NORTHWEST AIRLINES, INC.
McDONNELL DOUGLAS DC-9-82, N312RC
DETROIT METROPOLITAN WAYNE COUNTY AIRPORT
ROMULUS, MICHIGAN
AUGUST 16, 1987**

NTSB/AAR-88/05

UNITED STATES GOVERNMENT

**THESE CORRECTIONS SHOULD BE MADE
TO THE PREVIOUSLY PUBLISHED REPORT
IDENTIFIED AS FOLLOWS**

AIRCRAFT ACCIDENT REPORT

**NORTHWEST AIRLINES, INC.
McDONNELL DOUGLAS DC-9-82, N312RC
DETROIT METROPOLITAN WAYNE COUNTY AIRPORT
ROMULUS, MICHIGAN
AUGUST 16, 1987**

NTSB/AAR-88/05 (PB88-910406)

1. The last line on the bottom of page 28 should read:

a throttle split of about 2/3 of a throttle knob diameter. The measurements obtained were slightly less than half of the available throttle lever movement. The No. 2 engine was started to obtain a

2. Add the following finding to the bottom of page 67:

12. The loss of input from the airplane to the CAWS unit does not illuminate the CAWS fail light.

TECHNICAL REPORT DOCUMENTATION PAGE

| | | | | | |
|---|--|---|--|--|-----------|
| 1. Report No. NTSB/AAR-88/05 | | 2. Government Accession No. PB 88-910465 | | 3. Recipient's Catalog No. | |
| 4. Title and Subtitle: Aircraft Accident Report--Northwest Airlines, Inc., McDonnell Douglas DC-9-82, N312RC, Detroit Metropolitan Wayne County Airport, Romulus, Michigan, August 16, 1987 | | | | 5. Report Date May 10, 1988 | |
| | | | | 6. Performing Organization Code | |
| 7. Author(s) | | | | 8. Performing Organization Report No. | |
| 9. Performing Organization Name and Address National Transportation Safety Board Bureau of Accident Investigation Washington, D.C. 20594 | | | | 10. Work Unit No. 4717C | |
| | | | | 11. Contract or Grant No. | |
| | | | | 13. Type of Report and Period Covered Aircraft Accident Report August 16, 1987 | |
| 12. Sponsoring Agency Name and Address NATIONAL TRANSPORTATION SAFETY BOARD Washington, D.C. 20594 | | | | 14. Sponsoring Agency Code | |
| 15. Supplementary Notes | | | | | |
| 16. Abstract About 2046 eastern daylight time on August 16, 1987, Northwest Airlines, Inc., flight 255 crashed shortly after taking off from runway 3 center at the Detroit Metropolitan Wayne County Airport, Romulus, Michigan. Flight 255, a McDonnell Douglas DC-9-82, U.S. Registry N312RC, was a regularly scheduled passenger flight and was en route to Phoenix, Arizona. According to witnesses, flight 255 began its takeoff rotation about 1,200 to 1,500 feet from the end of the runway and lifted off near the end of the runway. After liftoff, the wings of the airplane rolled to the left and the right about 35° in each direction. The airplane collided with obstacles northeast of the runway when the left wing struck a light pole located 2,760 feet beyond the end of the runway. Thereafter the airplane struck other light poles, the roof of a rental car facility, and then the ground. It continued to slide along a path aligned generally with the extended centerline of the takeoff runway. The airplane broke up as it slid across the ground and postimpact fires erupted along the wreckage path. Three occupied vehicles on a road adjacent to | | | | | |
| 17. Key Words airplane configuration; flaps and slats retraction; central aural warning system; supplemental stall recognition systems; circuit breaker; flightcrew standardization; cockpit discipline | | | | 18. Distribution Statement This document is available to the public through the National Technical Information Service Springfield, Virginia 22161 | |
| 19. Security Classification (of this report) UNCLASSIFIED | | 20. Security Classification (of this page) UNCLASSIFIED | | 21. No. of Pages 142 | 22. Price |

CONTENTS

| | |
|--|----------|
| EXECUTIVE SUMMARY | v |
| 1. FACTUAL INFORMATION | |
| 1.1 History of the Flight | 1 |
| 1.2 Injuries to Persons | 4 |
| 1.3 Damage to the Airplane | 4 |
| 1.4 Other Damage | 5 |
| 1.5 Personnel Information | 5 |
| 1.6 Airplane Information | 6 |
| 1.6.1 Weight and Balance | 7 |
| 1.6.2 Flap and Slat Systems | 7 |
| 1.6.3 Takeoff Condition Computer | 9 |
| 1.6.4 The Digital Flight Guidance System | 9 |
| 1.6.5 Stall Protection System | 11 |
| 1.6.6 Central Aural Warning System | 12 |
| 1.6.7 CAWS Unit Self-Monitor System | 14 |
| 1.7 Meteorological Information | 15 |
| 1.8 Navigational Aids | 16 |
| 1.9 Communications | 16 |
| 1.10 Aerodrome Information | 16 |
| 1.11 Flight Recorders | 18 |
| 1.11.1 The Cockpit Voice Recorder | 18 |
| 1.11.2 The Digital Flight Data Recorder | 19 |
| 1.12 Wreckage and Impact Information | 22 |
| 1.13 Medical and Pathological Information | 25 |
| 1.14 Fire | 26 |
| 1.15 Survival Aspects | 26 |
| 1.15.1 Crash, Fire, Rescue | 27 |
| 1.15.2 Disaster Plans | 28 |
| 1.16 Tests and Research | 28 |
| 1.16.1 The CAWS Unit | 28 |
| 1.16.2 CAWS Sound Spectrum Analysis | 29 |
| 1.16.3 Electronic Equipment | 30 |
| 1.16.4 Cockpit Wiring and Circuit Breakers | 30 |
| 1.16.5 Flap Handle Module | 33 |
| 1.16.6 Airplane Performance | 33 |
| 1.17 Other Information | 37 |
| 1.17.1 Northwest Airlines and Republic Airlines Merger | 37 |
| 1.17.2 Proficiency Training | 39 |
| 1.17.3 The DC-9-82 Checklist | 41 |
| 1.17.4 Checklist Procedures | 41 |
| 1.17.5 Human Performance Research Projects | 43 |
| 1.17.6 FAA Surveillance | 46 |
| 1.18 Useful or Effective Investigative Techniques | 46 |
| 2. ANALYSIS | |
| 2.1 General | 47 |
| 2.2 The Accident | 48 |
| 2.3 The DFDR Readout and Airplane Performance Study | 49 |
| 2.4 The Physical Evidence | 50 |

| | | |
|------|---|-----|
| 2.5 | The Central Aural Warning System | 52 |
| 2.6 | Flightcrew Checklist Performance | 56 |
| 2.7 | Training | 62 |
| 2.8 | Automated Systems Use | 64 |
| 2.9 | Flightcrew Actions After Takeoff | 64 |
| 2.10 | The Captain's Hearing | 67 |
| 3. | CONCLUSIONS | |
| 3.1 | Findings | 67 |
| 3.2 | Probable Cause | 68 |
| 4. | RECOMMENDATIONS | 68 |
| 5. | GLOSSARY | 70 |
| 6. | APPENDIXES | |
| | Appendix A--Investigation and Hearing | 73 |
| | Appendix B--Personnel Information | 74 |
| | Appendix C--CVR Transcript | 75 |
| | Appendix D--Visual Displays of Flight 255 | 127 |
| | Appendix E--DC-9-82 Checklist | 137 |

EXECUTIVE SUMMARY

About 2046 eastern daylight time on August 16, 1987, Northwest Airlines, Inc., flight 255 crashed shortly after taking off from runway 3 center at the Detroit Metropolitan Wayne County Airport, Romulus, Michigan. Flight 255, a McDonnell Douglas DC-9-82, U.S. Registry N312RC, was a regularly scheduled passenger flight and was en route to Phoenix, Arizona, with 149 passengers and 6 crewmembers.

According to witnesses, flight 255 began its takeoff rotation about 1,200 to 1,500 feet from the end of the runway and lifted off near the end of the runway. After liftoff, the wings of the airplane rolled to the left and the right about 35° in each direction. The airplane collided with obstacles northeast of the runway when the left wing struck a light pole located 2,760 feet beyond the end of the runway. Thereafter the airplane struck other light poles, the roof of a rental car facility, and then the ground. It continued to slide along a path aligned generally with the extended centerline of the takeoff runway. The airplane broke up as it slid across the ground and postimpact fires erupted along the wreckage path. Three occupied vehicles on a road adjacent to the airport and numerous vacant vehicles in a rental car parking lot along the airplane's path were destroyed by impact forces and/or fire.

Of the persons on board flight 255, 148 passengers and 6 crewmembers were killed; 1 passenger, a 4-year-old child, was injured seriously. On the ground, two persons were killed, one person was injured seriously, and four persons suffered minor injuries.

The National Transportation Safety Board determines that the probable cause of the accident was the flightcrew's failure to use the taxi checklist to ensure that the flaps and slats were extended for takeoff. Contributing to the accident was the absence of electrical power to the airplane takeoff warning system which thus did not warn the flightcrew that the airplane was not configured properly for takeoff. The reason for the absence of electrical power could not be determined.

**NATIONAL TRANSPORTATION SAFETY BOARD
WASHINGTON, D. C. 20594**

AIRCRAFT ACCIDENT REPORT

**NORTHWEST AIRLINES, INC.
McDONNELL DOUGLAS DC-9-82, N312RC
DETROIT METROPOLITAN WAYNE COUNTY AIRPORT,
ROMULUS, MICHIGAN
AUGUST 16, 1987**

1. FACTUAL INFORMATION

1.1 History of the Flight

On August 16, 1987, a Northwest Airlines (Northwest) flightcrew picked up a McDonnell Douglas DC-9-82 airplane, N312RC, at Minneapolis, Minnesota, and operating as flight 750, flew the airplane to Saginaw, Michigan, with an en route stop at Detroit Metropolitan Wayne County Airport (Detroit-Metro), Romulus, Michigan, arriving at Saginaw about 1840 eastern daylight time. At Saginaw N312RC became flight 255 and was flown by the same flightcrew which had brought the airplane in. Flight 255, was a regularly scheduled passenger flight between Saginaw and Santa Ana, California, with en route stops at Detroit and Phoenix, Arizona. The flight was to be conducted in accordance with the provisions of 14 Code of Federal Regulations (CFR) Parts 91 and 121. About 1853, flight 255 departed Saginaw and about 1942 arrived at its gate at Detroit-Metro. Except for taxiing past and having to make a 180° turn to return to its assigned arrival gate, the flight to Detroit was uneventful.

After the disembarking passengers had left the airplane, a Northwest mechanic entered the cockpit and reviewed the airplane and cabin maintenance logbooks. He stated that no discrepancies were entered in either logbook. There was no record of any maintenance having been performed on the airplane while it was at Detroit-Metro.

About 10 to 15 minutes before the flight was due to depart the gate, a company transportation agent brought the flight release package to the airplane. He was met by the first officer who told him that the captain was not on board. The first officer inspected the package which contained the dispatch documents, signed the release, and returned the signed copy to the agent. As the agent left the airplane, he met the captain who had been conducting a walkaround inspection of the airplane and showed him the signed copy of the flight release. The captain studied the release, told the agent that it was all right, and thanked him.

About 2029, the final weight tabulation (weight tab) was delivered to the flightcrew. About 2032, flight 255 departed the gate with 149 passengers and 6 crewmembers on board. Flight 255 was pushed back to spot four. ^{1/} (See figure 1.) During the pushback, the flightcrew accomplished the BEFORE (engine) START portion of the airplane checkist, and, at 2033:04, they began starting the engines.

^{1/} A designated spot located on the outer ramp near taxiway Mike.

At 2034:40, after the engines had been started, the ground crew disconnected the tow bar from the airplane, and, at 2034:50, the west ground controller cleared the flight to "taxi via the ramp, hold short of (taxiway) delta and expect runway three center [3C] (for takeoff). . . ." The controller also informed the flightcrew that Automatic Terminal Information Service (ATIS) Hotel ("H") was now current and asked them if they had the information. The flightcrew repeated the taxi instructions and stated that they had the ATIS information. At 2035:43, the ground controller cleared flight 255 to continue taxiing, to exit the ramp at taxiway charlie (C), to taxi to runway 3C, and to change radio frequencies and then contact the ground controller on 119.45 Mhz. At 2035:46, the first officer repeated the taxi clearance, but he did not repeat the new radio frequency nor did he tune the radio to the new frequency. Thereafter, the first officer told the captain, "Charlie for three center, right."

ATIS "H" had been transcribed at 2028:35 and was being broadcast at the time of the accident. Examination of the cockpit voice recorder (CVR) recording showed that the flightcrew had not received information "H" before they began to taxi. However, at 2035:18, information "H" began on the first officer's radio channel, and, at 2035:55, he told the captain that he was leaving the airplane's No. 1 radio "to get the new ATIS."

About 2025, the tower supervisor began coordination to change Detroit-Metro from a runway 21 configuration to a runway 3 configuration. The change was completed at 2028. ATIS "H" was the first ATIS transcription to contain and broadcast this information. It also described the ceiling and visibility and stated in part that the temperature was 88° F, that the wind was 300° at 17 knots, and that ". . . ILS approaches are in use to runways three left (3L) and three right (3R) departing runways three . . . low level windshear advisories are in effect . . ."

The takeoff performance data in the flightcrew's dispatch package was based on using either runways 21L or 21R; however, the flight had been instructed by the ground controller to taxi to runway 3C, the shortest of the three available runways. The final takeoff weight for the airplane was 144,047 pounds. At 2037:08, the captain asked the first officer if they could use runway 3C for takeoff. Because of the runway change, the first officer had to refer to the company's Runway Takeoff Weight Chart Manual to verify that their takeoff weight was below the allowable limits for runway 3C. The takeoff weight chart showed that with the flaps set at 11°, the maximum allowable takeoff weights for runway 3C at 85° F and 90° F were 147,500 pounds and 145,100 pounds, respectively. After consulting the manual, the first officer told the captain runway 3C could be used for takeoff and the captain concurred with the first officer's evaluation.

During the taxi out, the captain missed the turnoff at taxiway C. When the first officer contacted ground control, the ground controller redirected them to taxi to runway 3C and again requested that they change radio frequencies to 119.45 Mhz. The first officer repeated the new frequency, changed over, and contacted the east ground controller. The east ground controller gave the flight a new taxi route to runway 3C, told them that ATIS "H" was still current, that windshear alerts were in effect, and that the altimeter setting was 29.85 inHg. The flightcrew acknowledged receipt of the information.

At 2042:11, the local controller cleared flight 255 to taxi into position on runway 3C and to hold. He told the flight there would be a 3-minute delay in order to get the required "in-trail separation behind traffic just departing." At 2044:04, flight 255 was cleared for takeoff.

The CVR recording showed that engine power began increasing at 2044:21 that the flightcrew could not engage the autothrottle system at first, but, at 2044:38, they did engage the system, and that the first officer called 100 knots at 2044:45.6. At 2044:57.7, the first officer called "Rotate," and, at 2045:05.1, the stall warning stick shaker activated and continued operating until the CVR recording ended. At 2045:09.1, 2045:11.4, 2045:14.3, and, 2045.17.1, the aural tone and

voice warnings of the supplemental stall recognition system (SSRS) also activated. Between 2044:01 and 2045:05.6, the CVR recording did not contain any sound of the takeoff warning system indicating that the airplane was not configured properly for takeoff.

Witnesses generally agreed that flight 255's takeoff roll was longer than that normally made by similar airplanes. They stated that the flight began its rotation about 1,200 to 1,500 feet from the departure end of the runway, agreed that it rotated to a higher pitch angle than other DC-9s, and agreed that the tail of the airplane came close to striking the runway.

Only a few witnesses recalled any details about the position of the airplane's leading edge wing slats, trailing edge wing flaps, or landing gear. Most of these witnesses said that the landing gear was retracted after liftoff. Two Northwest first officers recalled that the flaps and slats were extended. One first officer was in the airplane directly behind flight 255 in the takeoff sequence. According to her, "the flaps were extended, which is normal, but I could not . . . state the actual degree of flap extension." She did not describe the position of the slats. The second first officer's airplane was parked on taxiway "A" between the ramp and taxiway "J." The airplane was facing runway 3C and about 150 feet from it. (See figure 1.) He testified that he observed the flaps and slats as flight 255 rolled past his airplane and, "The slats and flaps were extended." However, he was unable to estimate their degree of extension.

After flight 255 became airborne it began rolling to the left and right. Witnesses estimated that the bank angles during the rolls varied from 15° to 90°. Some witnesses stated that the airplane wings leveled briefly and then banked to the left just before the left wing hit a light pole in a rental car lot. Most witnesses did not see fire on the airplane until it was over the rental car lot. The first officer of the Northwest airplane parked on taxiway "A" testified that flight 255 was intact until the left wing struck the light pole in the auto rental car lot. After the wing struck the pole, he saw what appeared to be "a four- to five-foot chunk of the wing section . . ." fall from the airplane. He did not see any fire on the airplane until after it struck the light pole and then he saw "an orange flame . . ." emanating from the left wing tip section.

After impacting the light pole, flight 255 continued to roll to the left, continued across the car lot, struck a light pole in a second rental car lot, and struck the side wall of the roof of the auto rental facility in the second rental car lot. Witnesses stated that the airplane was in a 90° left-wing-down attitude when it struck the roof and that it continued rolling and was still rolling to the left when it impacted the ground on a road outside the airport boundary. The airplane continued to slide along the road, struck a railroad embankment, and disintegrated as it slid along the ground. Fires erupted in airplane components scattered along the wreckage path. Three occupied vehicles on the road and numerous vacant vehicles in the auto rental parking lot along the airplane's path were destroyed by impact forces and or fire.

On board flight 255, 148 passengers and 6 crewmembers were killed; 1 passenger, a 4-year-old child was injured seriously. On the ground, two persons were killed, 1 person was injured seriously, and 4 persons suffered minor injuries.

The coordinates of the accident were 42°14' N latitude and 85°20' W longitude.

1.2 Injuries to Persons

See table 1.

1.3 Damage to the Airplane

Table 1.--Injuries to Persons

| | <u>Crew</u> | <u>Passengers</u> | <u>Other</u> | <u>Total</u> |
|---------|-------------|-------------------|--------------|--------------|
| Fatal | 6 | 148 | 2 | 156 |
| Serious | 0 | 1 | 1 | 2 |
| Minor | 0 | 0 | 4 | 4 |
| None | 0 | 0 | 0 | 0 |
| Total | 6 | 149 | 7 | 162 |

The DC-9-82 was destroyed by ground impact and postimpact fires. According to the October 1987 Worldwide Aviation and Marketing Service (AVMARK) Newsletter, the price of a DC-9-82 varied between about \$20.5 million and \$21.5 million depending on how it was equipped.

1.4 Other Damage

The front and rear walls above the roof of the auto rental facility were damaged by impact forces and fire; the roof was damaged by fire. Three light standards in the rental car lots were damaged by impact forces. Numerous unoccupied automobiles in the rental car parking lot were damaged or destroyed by either impact forces, fire, or both. Two automobiles and a GMC truck located on the road outside the airport boundary were destroyed by either impact forces, fire, or both.

1.5 Personnel Information

The flightcrew and cabin crew of flight 255 were qualified in accordance with applicable Federal and Northwest regulations and procedures. (See appendix B.) Examination of the flightcrew's training records did not reveal anything unusual. In addition, the investigation of the flightcrew's personal background and actions during the 2 to 3 days before the accident flight did not reveal anything remarkable.

The Captain.-- The 57-year-old captain was hired originally by West Coast Airlines on October 3, 1955. In 1980, as a result of two mergers, West Coast evolved into Republic Airlines. On January 23, 1986, Northwest Airlines bought Republic Airlines and the combined companies were renamed Northwest Airlines Inc. The captain remained employed continuously by the companies throughout the transactions. During his 31 years with these companies, the captain was type rated on seven different airplanes ranging from the McDonnell Douglas DC-3 to the Boeing 757 (B-757). He also served as a Federal Aviation Administration (FAA) designated check airman in the B-727 (September 1978-July 1979) and the DC-9 and DC-9-82 (September 1979-April 1984) airplanes.

The captain upgraded initially to captain in December 1972. Except for one 17-month period during 1978-79 and one of about 4 months during 1985 while serving as captain on Boeing 727s (B-727), the captain had flown airplanes with a two-pilot crew. (See appendix B.)

The captain had upgraded to captain on the B-757 in February 1986. However, after the merger, Northwest disposed of the six B-757s which had been operated by Republic. The disposal of these airplanes required the captain to return to the DC-9-82. ^{2/} The captain requalified as captain in the DC-9-82 in May 1987. Northwest pilots are not cross utilized in the DC-9-82 and other DC-9 series airplanes. Since May 1987, the captain had been assigned to and had flown only the DC-9-82.

Virtually all of the interviewed first officers and other captains who had flown with the captain described him as a competent and capable pilot. They stated that the captain always used the airplane checklist. One first officer stated that the captain had a reputation "as a strict, by-the-book pilot who would not tolerate any deviation from standard procedures."

Three of the captain's present or former supervisors stated that they had never had any professional or personal problems with him.

The First Officer. --The 35-year-old first officer was hired by North Central Airlines in May 1979. Republic Airlines resulted from a merger of North Central and Southern Airlines. The first officer has been employed continuously by North Central, Republic, and Northwest Airlines since his date of hire.

With the exception of one training report during his early probationary period with the airline, all of the captains with whom the first officer had flown graded his performance as average or above average. Comments contained in some of his grade sheets described him as follows: "competent pilot," "easy to work with," "good in all respects," and "very personable, thorough job..."

One captain with whom the first officer recently had flown stated that he appeared to be a good pilot. Although he did not remember if the first officer had initiated checklists, he stated that the first officer did not appear to be a "yes man" and that he remembered the first officer handling a very busy period "very well and calling a potential problem [to his] attention." Other captains who recently had flown with the first officer described his ability and performance in favorable terms.

The first officer's supervisors stated that they had not had any personal or professional problems with him.

The Northwest records showed that the captain and first officer had flown together on August 7-10 and 14-15, 1987. During this 6-day period they had flown 18 trip legs.

1.6 Airplane Information

The DC-9-82, U.S. Registration N312RC, was manufactured on October 15, 1981; it was delivered to Republic Airlines on December 8, 1982. Since delivery, N312RC has been operated by Republic Airlines and, after its purchase of Republic, by Northwest Airlines, Inc.

The airplane was powered by two Pratt and Whitney Model JT8D-217 turbofan engines. The JT8D-217 engine has a normal and maximum sea level static thrust ratings of 20,000 pounds and 20,850 pounds at 84° F and 77° F, respectively; these ratings are limited to 5 minutes.

^{2/} The DC-9-82 is a derivative of the McDonnell Douglas DC-9-80 series airplane. The airplane is also referred to as MD-80 or MD-82. The description DC-9-82 will be used herein unless a referenced publication, document, or quote specifies another name, in which case the referenced name will be used.

Examination of the airplane flight and maintenance logbooks did not reveal any discrepancies or malfunctions that would have contributed to the accident. In addition, the examination disclosed that, at the time of the accident, there were no discrepancies or malfunctions in the logbooks involving minimum equipment list (MEL) items. ^{3/}

1.6.1 Weight and Balance

According to the Northwest DC-9-82 Airplane Pilots Handbook (APH), the maximum certificated takeoff weight of the airplane is 149,500 pounds. The airplane is limited to a maximum tailwind of 10 knots for takeoff and landing and a maximum demonstrated crosswind of 30 knots for takeoff and landing. The actual airplane weight for the takeoff at Detroit Metro was 144,047 pounds, its computed center of gravity (c.g.) for the ensuing takeoff was 9.8 percent of the mean aerodynamic chord (MAC) of the wings and was within the forward and aft c.g. limits of 3.1 percent and 24.4 percent MAC, respectively.

The CVR showed that the latest runway temperature information known to the flightcrew was the 88° F reading contained in ATIS "H." The CVR also showed that the flightcrew planned to use 11° flaps for the takeoff. Based on the 88° F ambient temperature, flaps at 11°, and the slats at the takeoff or mid-sealed position, the company's takeoff weight chart showed that the maximum allowable takeoff weight for runway 3C was 146,060 pounds and that reduced engine thrust could not be used for takeoff. The required engine pressure ratio (EPR) for the ensuing takeoff would have been 1.95. The takeoff weight charts provided weight corrections based on headwind or tailwind components. On runway 3C, the maximum allowable weights either could be increased by 230 pounds for each knot of headwind or had to be decreased by 960 pounds for each knot of tailwind.

1.6.2 Flap and Slat Systems

The trailing edge flaps and leading edge slats are extended and retracted by the flap/slat handle (flap handle) located on the right side of the control pedestal.

The wing trailing edge flap system consists of an inboard and outboard flap segment on each wing. Each flap segment is powered by an inboard and outboard hydraulic cylinder on each wing. The outboard cylinders are operated by the left hydraulic system; the inboard cylinders are operated by the right hydraulic system. Although the flaps normally operate on pressure from both hydraulic systems, they will operate on a single system at a reduced rate. All flap segments are linked together mechanically to provide synchronization during extension and retraction.

Six fixed position detents are located along the left side of the flap handle, track, or race: UP/RET, 0°, 11°, 15°, 28°, and 40°. When the flap handle is positioned in any of the detents, a pin on the left side of the handle drops into the detent and keeps the handle at the selected position while the flaps move to the commanded position. To move the flap handle from, for example, the 11° detent to the UP/RET detent, a spring-loaded lever, or trigger, on the left side of the handle must be raised to release the pin from the detent. As the lever is moved forward, the trigger must be held in the raised position until the flap handle has cleared the 0° detent. After passing the detent, the trigger must be depressed to transit the slat retract gate and reach the UP/RET detent.

^{3/} A list containing the equipment and procedures required for continuing flight beyond a terminal point.

The numbers on the fixed position detents describe the flap position in degrees. When the flap handle is in the UP/RET detent, the flaps and leading edge slats are retracted. When the flap handle is in the 0° detent, the flaps are still retracted, but the slats are extended to the mid-sealed position. When the flap handle is moved to the 15° or higher degree detents, i.e. the 28° or 40° detents, the slats extend fully.

A movable, or dial-a-flap detent allows the flightcrew to select takeoff flap settings anywhere in the 0° to 13° range or 15° to 24° range. The movable detent is positioned by a thumbwheel on the flap handle module. It moves along the right side of the flap handle track and provides a detent which is engaged by a pin on the right side of the flap handle. A takeoff flap setting in the 0° to 13° range will extend the slats to the mid-sealed position; flap settings in the 15° to 24° range will place the slats in the extended position. The movable detent was not used for the accident takeoff.

The flap positions are portrayed on an indicator located on the lower right side of the center instrument panel and almost directly in line with the flap handle. A transmitter mounted on the inboard hinge of each outboard flap segment provides flap position information to the cockpit indicator, the stall warning computer, and the digital flight guidance computers (DFGC). The flap position indicator contains superimposed pointers and a dial which is graduated in degrees of flap travel. The pointers respond to actual flap movement and will normally move in unison.

The slats are wing lift augmentation devices located on the leading edge of the wings. Each wing slat is divided into six segments that are fastened together and operate as a single unit. Each slat is actuated by two hydraulic cylinders. One cylinder is operated by the left hydraulic system and the other cylinder is operated by the right hydraulic system. The actuating cylinders extend and retract the slats through a pulley, a closed cable, and a track system. The slats normally are operated by pressure from both hydraulic systems, but they will continue to operate, at a reduced rate, by pressure from a single hydraulic system. Movement of the flap handle from the UP/RET position drives a pushrod to rotate a cable drum in the lower portion of the control pedestal. Two closed loop cable systems transmit the handle motion to a cable drum within the flap and slat sequence mechanism which in turn positions hydraulic control valves to extend the slats.

Positioning the flap handle to the 15° or higher degree detents will move the slats to the extended position. The movement of the flap handle through this selection range rotates a cable drum in the control pedestal. The rotation of the cable drum drives a nonadjustable pushrod which positions a synchro and a rotary switch containing five microswitches. The synchro provides a flap position signal to the speed command system. Two microswitches are used in the slat position indication system; one microswitch provides information to the auto brake system, and the two remaining microswitches provide 28 volt d.c. (28V d.c.) signals to the two stall warning computers. The output of the stall warning computers drive two electric jackscrew actuators (the autoslat actuators) to position the hydraulic control valves to drive the slat to the extended position in response to the pilot commands from the flap handle.

Slat position status is provided by four slat advisory lights located to the right of the flap position indicator. When the flap/slat handle and slats are in takeoff range the takeoff light (blue) will illuminate. The other three positions that can be displayed by the advisory lights are disagree, auto, and land. These advisory lights are not lit when the slats are retracted.

1.6.3 Takeoff Condition Computer

The Takeoff Condition Computer (TCC) is used by the flightcrew to determine the airplane's stabilizer trim setting for takeoff. The stabilizer trim settings are determined by entering calculated takeoff values for c.g. and flap setting into the computer mounted on the left side of the control pedestal. When the appropriate c.g. and flap setting appear in their respective readout windows, the stabilizer setting numeric value will appear in the takeoff condition longitudinal trim window and the computer will position the longitudinal trim takeoff position indicator to the same value contained in the trim window. This value may then be set by moving the stabilizer until its longitudinal trim indicator is aligned with the longitudinal trim takeoff position indicator. In addition, the flap setting inserted into the takeoff condition computer is used as the reference value by the takeoff warning system to determine that the flaps are set for takeoff.

1.6.4 The Digital Flight Guidance System

Thrust Computer Indicator.--The thrust computer indicator (TCI) provides EPR limit values for six flight modes based on temperature. The modes of flight, which can be selected by depressing the appropriate pushbuttons on the TCI, include takeoff (T.O.), reduced thrust takeoff or takeoff flexible (T.O. FLX), go-around (GA), maximum continuous thrust (MCT), climb (CL), and cruise (CR).

Flight Director System.--The DC-9-82 is equipped with a flight guidance system for flight guidance throughout the entire flight envelope (takeoff to landing). The flight director (F/D) function of this system provides visual guidance commands to fly the airplane manually or to visually monitor autopilot and autothrottle response to the guidance commands. Flight guidance system operating modes can be selected for the F/D function with autopilot and autothrottle functions disengaged. The F/D modes selected by the pilots are annunciated on the pilot's flight mode annunciators (FMA) located on the top of each pilot's instrument panels. The digital flight data recorder (DFDR) records the F/D and autothrottle system modes that are annunciated on the FMA.

Pitch and roll data from the flight guidance computers are displayed on the attitude director indicator (ADI). A V-shaped command bar (command bar) directs the pilot to turn, climb, or descend. Although the F/D provides visual guidance commands throughout the entire flight envelope, the events leading to the accident occurred during the takeoff roll and initial liftoff phases of flight. Therefore the discussion herein will be limited to the takeoff mode of operation which was relevant to those phases of the flight.

The F/D's "Takeoff" mode uses two different methods to position the command bars from takeoff roll up to the altitude at which the F/D is either turned off or the pilot selects another mode of operation. The method of operation is based on either the airplane's height above the ground or the elapsed time since liftoff. After the airplane has either climbed to 80 feet agl or 11 seconds have elapsed since main gear liftoff, whichever occurs first, the F/D's commands compensate for changes in the airplane's flap/slat configuration. The control laws in the digital flight guidance computers (DFGC) continuously calculate the desired reference speed for the existing airplane configuration, compare the actual airspeed to the reference speed, and position the command bar to provide the appropriate nose-higher or nose-lower cues to the pilot to correct the variation between the actual and reference airspeeds.

The F/D operates differently when the airplane is either below 80 feet agl or before the requisite 11 seconds since main gear liftoff has expired. The DFGC laws use longitudinal acceleration (in the form of airspeed change) airplane configuration, and angle of attack. The F/D's system logic is designed to provide a target pitch attitude after rotation as the airplane is accelerating to the first segment climb speed. It assumes that the airplane is in an acceptable takeoff configuration and is rotated at the proper speed for that configuration. While the airplane is still on

the runway and below the normal climb speed, the F/D predicts what the pitch attitude should be and positions the command bar to display this attitude during rotation and liftoff. However, the command bar position only displays 37 percent of the unsatisfied pitch command. For example, if the predicted pitch attitude during the takeoff roll was 20° nose-up, the command bar position would present a 7° nose-up pitch command to the pilot. The major contribution to the display is acceleration.

After rotation, the airplane's horizontal acceleration declines because the energy used to accelerate it is traded for climb angle. The F/D cue, still a predictor of proper pitch attitude continues to use the airplane's configuration and angle of attack, and it compares the predicted flightpath angle to the actual flightpath angle which is calculated from the existing vertical speed and airspeed. The sum of the predicted flightpath angle and the required angle of attack (based on airplane configuration) yield the commanded pitch attitude. As a result, the F/D command bar generally will require a nose-up attitude which will allow the airplane--with both engines operating at takeoff power--to reach $V_2 + 10$ KIAS at 35 feet agl and to maintain that airspeed. After the airplane either climbs through 80 feet or 11 seconds have elapsed after main gear liftoff, whichever occurs first, the DFGC adds a reference airspeed term to determine the applicable pitch attitude correction.

After the F/D has been turned on, pressing either of the two takeoff-go-around (TOGA) palm switches while the airplane is operating in ground mode will place the F/D in the takeoff mode; pressing either switch after the airplane lifts off places the F/D in the go-around mode. (A TOGA palm switch is located on each throttle lever just below the knob on top of the lever.) The FMA annunciations recorded by the DFDR showed that the F/D entered the go-around mode about 4 seconds after the weight of the airplane had moved off its main landing gears. After go around has been selected the F/D commands a minimum + 6° flightpath angle by inserting a nose-up pitch command above the existing command bar position for about 7 seconds. In this case, the command bar would rise about 2° above the existing position. Thereafter it will phase in speed command data to reposition the command bar. Assuming the flaps were at 11° and the slats were in the mid-sealed position, with both engines operating, the command bars would have commanded a pitch attitude which would capture and maintain $V_2 + 10$ KIAS. However, assuming that the flaps and slats were retracted, with both engines operating, the command bars would be positioned to command a pitch attitude which would capture and maintain 1.5 V_s , $5/$ or about 252 KIAS. At the Safety Board's public hearing in Romulus, the director of the McDonnell Douglas Flight Guidance and Controls Design Engineering Department testified, however, that the accident flight had terminated before the F/D presented any commands designed to achieve the 1.5 V_s target speed.

With regard to takeoff procedures, the normal procedures section of the Northwest APH states that, at the call of rotate, the pilot flying "will initiate a smooth steady up elevator movement normally requiring a positive pull force and approximately a 6-8 second interval to rotate to a maximum of 20° pitch attitude. Following the V COMMAND bar will give proper V_2 pitch attitude."

Autothrottle System--The autothrottle system (ATS) function of the autothrottle speed command system automatically positions the throttles to maintain airspeed or engine thrust as required for the operational mode selected and the airplane control configuration. The ATS will control the throttles for the following maneuvers: takeoff, climb, cruise, holding, approach, flare, and go-around. The ATS is engaged by moving the autothrottle switch on the flight guidance

4/ V_2 --Takeoff safety speed.

5/ The stalling speed or the minimum steady flight speed at which the airplane is controllable.

control panel on the glare shield from the OFF position to the autothrottle (AUTO THROT) position. The solenoid-held switch will not remain in the AUTO THROT (engage) position until all interlocks and engage requirements have been satisfied.

The ATS takeoff mode will provide automatic engine thrust control during the takeoff roll, liftoff, and climbout. However, with the F/D in takeoff mode, the autothrottle switch will not engage unless the TCI has been placed in either the T.O. or T.O. FLX modes. Thus, the ATS takeoff mode is initiated by selecting T.O. or T.O. FLX on the TCI, pushing the takeoff palm switch on the throttle, and engaging the autothrottle switch on the flight guidance control panel. When the autothrottle switch has been engaged, the ATS will advance the throttles until the EPRs have reached the limit set in the TCI. When the airplane has accelerated to 60 KIAS, the ATS will enter the clamp mode. Power is removed from ATS's servo motor, movement of the autothrottles is prevented during rotation and liftoff, and the acronym "CLMP" is annunciated in the thrust window of the FMA.

Automatic Reserve Thrust System.--During takeoff, the automatic reserve thrust system (ART) provides automatic engine failure detection and a subsequent thrust increase on the operating engine. The system is completely self-testing and requires no action by the flightcrew except for extending the slats and enabling the system by placing the guarded ART switch in the automatic (AUTO) position. Two annunciator lights are provided on the center instrument panel. With both engines running and the self-test function satisfied, a green READY light illuminates when the slats have been extended, indicating that the system is available for use. An amber ART light indicates that the system has detected a 30 percent differential in N₁ rpm and the ART solenoid in the fuel control has actuated to provide the increased thrust on the remaining engine. The system is disabled automatically when the slats are retracted after takeoff, extinguishing the green READY light.

1.6.5 Stall Protection System

The DC-9-82 uses a two-computer stall warning recognition and protection system; either computer can detect an approach to stall and operate the system. The system monitors angle of attack (AOA), the rate of change of the AOA, and airplane configuration to provide several warnings to the pilots. When the airplane is in a takeoff configuration, i.e., the flaps and slats are extended to their commanded positions, the system will predict an impending stall, activate the autoslat extend portion of the warning, and extend the slats from the mid-sealed to the full-extend position. If the near stall condition persists or develops again, the stick shaker will activate providing the pilot with the standard Federal Aviation Administration (FAA) prescribed warning of impending stall. This warning has at least a 4 percent speed margin above the 1 G stall speed. ^{6/} As the AOA increases to near the stall AOA, a supplemental stall recognition system (SSRS) will illuminate "STALL" signs on the left and right sides of the cockpit glare shields, activate a series of aural tones, and state the word, "stall." This is an announcement that the stall AOA has been reached and that there is no more safety margin. If the condition lasts for 6 seconds or the AOA increases an additional 3°, a post stall recovery system (PSRS) activates a stick pusher that forces the control column forward, pitching the airplane in a nose-down direction. If the slats are retracted, autoslat extension and the PSRS are disabled.

^{6/} Title 14 CFR 25.201(d)(1) states, in part, that the "airplane may be considered stalled when, at an angle of attack measurably greater than that for maximum lift, the inherent flight characteristics give a clear and distinctive indication to the pilot that the airplane is stalled." The flight characteristics used to determine the stall speed of the DC-9-80 series airplanes are contained in 14 CFR 25.201(d)(1)(ii) which states, in part, "A roll that cannot be readily arrested . . ."

1.6.6 Central Aural Warning System

The DC-9-82's central aural warning system (CAWS) provides distinctive aural (horn, "C" chord, chime, and bell sounds) and vocal (electronically-generated system identification words) indications when potentially unsafe operating conditions, unsafe airplane configurations, or system malfunctions exist. Each voice message is preceded by an associated warning tone. The voice message is cycled with a 1-second aural tone, followed by a 1-second voice message identifying the unsafe configuration, condition, or malfunction for the duration of the warning period. The CAWS contains 12 defined warning systems; however, given the circumstances of the accident, the discussion herein will center on the SSRS and the takeoff warning system.

The components of the CAWS include the CAWS unit located on the forward right radio rack in the electrical and electronics compartment and two speakers located, one each, in the captain's and first officer's side consoles. The CAWS unit contains three internal power supplies which are powered individually by 28V d.c. electrical power from the airplane's electrical distribution system. In accordance with Federal certification requirements, circuit breakers have been installed on the 28V d.c. input lines to protect the airplane's electrical system from overloads caused by high electrical current draws. The three circuit breakers are located on the circuit breaker panel mounted on the aft cockpit bulkhead directly behind the captain's seat. Thus, the 28V d.c. input to power supply-1 within the CAWS unit is routed from the d.c. transfer bus through circuit breaker U-31; ^{2/} the 28V d.c. input to power supply-2 is routed from the left d.c. bus through circuit breaker P-40; and the 28V d.c. input to power supply-3 is routed from the right d.c. bus through circuit breaker R-41. The failure or loss of power to any of the three d.c. distribution buses will be annunciated by a failure light on the overhead cockpit annunciator panel. The failure of either the left or right d.c. bus also illuminates the airplane's master caution light.

The 12 warning systems are divided among the three power supplies of the CAWS units. Except for the SSRS, there is no redundancy, and the failure of a power supply will result in the loss of its associated warning systems. SSRS-1 operates off power supply-2 and SSRS-2 operates off power supply-3. When SSRS-1 and -2 are activated by the stall protection system, SSRS-1 will provide a tone and the word "stall" to the captain's speaker; it also will illuminate the stall warning light on the captain's side of the glare shield. SSRS-2 will provide the same data to the first officer's speaker and will illuminate the stall warning light on his side of the glare shield. Although SSRS-1 and -2 are activated simultaneously, the word warnings are not, and one word trails the other by a small fraction of time and produces an "echo" type sound within the cockpit. According to the Northwest APH, flightcrews must check the stall warning system during the RECEIVING AIRPLANE checklist. The APH states, in part, that the RECEIVING AIRPLANE checklist will be completed when originating a flight following an overnight layover; when a new flightcrew accepts an airplane; when an interrupted flight is resumed when the airplane has been left unattended for an extended period of time or the TERMINATING checklist has been completed; when maintenance has been performed that requires the repositioning of cockpit switches with no crewmember present; and whenever the captain deems it necessary. The APH contains the following note:

During the aural portion of the test, an echo effect will be heard if both channels are producing the STALL voice of the central aural warning system at the same time.

^{2/} Grid positions are used to locate each circuit breaker on this panel. Circuit breaker U-31 is on horizontal row "U" and vertical row No. 36.

The takeoff warning system is powered by power supply-2 and is programmed to provide a modulating horn for 1 second, followed by a voice warning identifying the system or systems, control or controls not properly configured for takeoff. Thus, if the slats are not set for takeoff and the slat takeoff light is not illuminated, the warning system will state the word "slats"; if the flap handle is not in agreement with the value set in the flap window of the takeoff condition computer, the warning system will state the word "flaps;" and, if the horizontal stabilizer is not set within the green band of the longitudinal trim indicator, the warning system would state the word "stabilizer." If more than one out-of-configuration condition exist, the voice warning will identify, in turn, each out-of-configuration control.

The takeoff warning system is disabled in flight by the R2-5 ground sense relay. This relay is controlled electrically by the operation of the nose gear strut and removes power from the warning system when the strut extends on takeoff.

At the time of the accident, the APH required the flightcrew to check the takeoff warning system during the RECEIVING AIRPLANE checklist. The check is made during the spoiler check when the throttles are advanced to about 4 inches of throttle travel to check the performance of the spoiler lever. The APH states, in part:

The takeoff warning horn will sound after the throttles have been advanced to the takeoff position. Allow the CAWS to cycle through at least one cycle: " STABILIZER, AUTO BRAKES, BRAKES, FLAPS AND SLATS."

The warning is activated by throttle lever position and not by engine power settings.

The company MEL required the takeoff warning system to be operational for flight. Given the checklist requirement that the system be checked during the RECEIVING AIRPLANE checklist, the system should have been checked before the airplane departed Santa Ana for Minneapolis and by the accident flightcrew when they took over the airplane at Minneapolis. The captain who flew the airplane to Minneapolis testified that he had checked the system before leaving Santa Ana and found it functional. In addition, a Northwest first officer who rode in the cockpit jump seat with the accident flightcrew from Detroit to Saginaw on the day of the accident testified that the captain had to add power to make a sharp turn off the runway to a taxiway. He stated that during the turn he heard the words "flaps, flaps" annunciated by the SSRS. He testified that he did not recall hearing the warning horn, just the vocal warning.

On September 1, 1987, McDonnell Douglas issued a telex to all DC-9-80 operators. The telex recommended that the airplane checklist be changed and that the takeoff warning system be checked before departing the gate on each flight. All DC-9-80 operators have incorporated this change in their checklist procedures.

On September 23, 1987, the FAA issued a memorandum creating a special team to review the performance of takeoff configuration warning systems on all type air carriers so equipped and the procedures used by the carriers' flightcrews to verify that the warning system is operational. The review team investigated the types of takeoff warning systems that are in use and the procedures used by maintenance and flightcrew personnel to check the performance of these systems. As of the date this report was adopted the review team has not released the results of its investigation.

1.6.7 CAWS Unit Self-Monitor System

Normal operation of the CAWS occurs when the airplane's 28V d.c. buses are energized and the circuit breakers protecting the input lines to the CAWS unit are closed. The CAWS unit has a self-monitoring capability that encompasses about 80 percent of its internal components. When an internal failure is detected, CAWS fail lights on the overhead cockpit annunciator panel and on the front of the unit are illuminated. If the failure mode within the unit is corrected, the annunciator light in the cockpit will go out. However, the fail light on the unit is operated by a latching-type relay and once lit, the relay latches and the light remains lit until the unit is removed by maintenance personnel, opened, and the relay is reset.

Although the self-monitoring programs compare the input power to and the output power from the three power supplies within the CAWS unit, the program logic will not classify the loss of 28V d.c. input to a power supply as a fault and illuminate the two fail lights. In this case, the logic would note that there is no power output from the power supply because input power is missing, and therefore, the internal power supply has not malfunctioned. During the postaccident investigation in a like-type airplane and CAWS unit, the P-40 circuit breaker latch was opened manually removing 28V d.c. power from power supply-2 of the CAWS unit. The two CAWS fail lights did not illuminate.

During the development of the CAWS for certification by the FAA, McDonnell Douglas and the FAA conducted a failure mode and effects analysis (FMEA) of the system. The FMEA analyzed the types of possible system failures, how the failures could be detected, and the results of the failures. Severity of the hazards to flight resulting from these failures were categorized into four classes: Class I - Safe; Class II - Marginal; Class III - Critical; and, Class IV - Catastrophic. Also, the FMEA evaluated whether the airplane could be dispatched with a particular component or system inoperative. The failure of the entire CAWS and the failure of just the takeoff warning channel of the CAWS were classified as a Class I risk. The FMEA stated that the airplane should not be dispatched with an inoperative CAWS, but it could be dispatched with the takeoff warning channel inoperative.

With regard to the takeoff warning channel, the FMEA stated that the loss of the input 28V d.c. to power supply-2 will cause the CAWS fail lights to illuminate. The director of the McDonnell Douglas Flight Guidance and Controls Design Engineering Department and a supervisory aerospace engineer in the Systems and Equipment Branch at the FAA Aircraft Certification Branch, Long Beach, California, testified this statement was erroneous. The FAA supervisory aerospace engineer testified that FAA approval of FMEAs of noncritical systems were normally granted by an FAA-designated engineering representative (DER). ^{8/} However, in this case, because the incumbent DER did not have the requisite experience to approve the FMEA, it was submitted to the Systems and Equipment Branch at the Aircraft Certification Branch where it was approved.

The FAA supervisory aerospace engineer also testified that the FMEA would have been approved even if it had portrayed correctly that the loss of the 28V d.c. input power would not illuminate the CAWS fail lights, "because it's a non-essential system. There's other means by which the pilot can verify the event that's causing that warning or would cause the warning had it not failed. There's other means by which he would normally check his airplane."

^{8/} An employee of the manufacturer deputized by the FAA in accordance with the provisions of 14 CFR Part 183.11(c)(1) to review and verify certain elements of the design.

Finally, with regard to the cockpit CAWS fail light, the McDonnell Douglas director of Flight Guidance and Controls Design Engineering testified that the light was installed as a maintenance aid and that "if the crew had any squawks about the central aural warning system, if there weren't a light, [maintenance personnel] would have to climb around the avionics compartment and first off run through the tests on the front of the [CAWS unit] and see if there was a fault light We thought it would be an aid to the maintenance of the airplane to put a light in the overhead which would indicate the computer had failed . . . the flightcrew could write it up . . . if the light were on . . . and the maintenance crew would know where to go." He testified that this was the reason that the CAWS unit monitors only its internal components.

1.7 Meteorological Information

The August 16, 1987, 2000 surface map, prepared by the National Weather Service (NWS), showed a low-pressure system just north of central Lake Superior with a cold front extending south then south-southwest through central Wisconsin, southwestern Iowa, northwestern Missouri, and into the Texas Panhandle. There was an instability line about 60 miles to the east and parallel to the front from northwestern Wisconsin into north central Texas. Conditions in the vicinity of Detroit were characterized by light, southerly winds; broken clouds; and haze.

The following aviation surface weather observations were recorded by the NWS at Detroit-Metro before and at the approximate time of the accident:

Time--1950; clouds--2,500 feet scattered, 4,500 feet scattered, ceiling estimated 15,000 feet broken; 25,000 feet broken; visibility--6 miles, haze; temperature--88° F; dew point--68° F; wind--180°/ 7 knots; altimeter--29.83 inHg.; remarks--cumulonimbus west through northwest through north moving east.

Time--2048; clouds--2,500 feet scattered, ceiling estimated 4,500 feet broken, 10,000 feet overcast; visibility--6 miles, haze; temperature--79° F; dew point--66° F; wind--280°/12 knots; altimeter--29.85 inHg.; remarks--cumulonimbus northwest through north moving east.

At 1930, the NWS radar observation at Detroit-Metro placed the airport within an area that was 3/10 covered by thunderstorms with very heavy rain showers and thunderstorms that were increasing in intensity. The cells were moving from 260° at 20 knots, and the maximum top was 40,000 feet 21 miles west of the airport.

At 2054, the NWS radar observation placed Detroit-Metro within an area that was 5/10 covered by thunderstorms with very heavy rain showers. The cells were moving from 260° at 25 knots, and the maximum top was 40,000 feet 39 miles northeast of the airport.

The NWS radar observer at Selfridge Air Force Base, Michigan, stated that there were no thunderstorms in the immediate vicinity of Detroit-Metro at the time of the accident. Between 2000 and 2010, the Detroit Edison Company's lightning detection system recorded a lightning strike about 12 miles north-northwest of Detroit-Metro, and between 2000 and 2100, no other lightning activity was recorded in Wayne County.

Only one pilot report (PIREP) pertinent to Detroit-Metro was found on the teletype summaries at the Detroit Flight Service Station (FSS). The PIREP stated, in part, that at 2006, a Boeing 727 had encountered moderate turbulence 5 miles west of Detroit-Metro.

The following winds were recorded by the centerfield anemometer of Detroit-Metro's low level windshear alert system (LLWAS). (See section 1.10.)

From 2015:52 to 2016:49 --- 220° magnetic (M) to 230° M at 8 to 9 knots.

From 2016:16 to 2018:54 -- 230° M to 280° M at 8 to 14 knots gusting to 30 knots.

From 2019:10 to 2020:16 -- 280° M to 300° M at 16 to 21 knots gusting to 30 knots.

From 2021:39 to 2022:37 -- 290° M at 19 to 21 knots.

From 2029:31 to 2030:29 -- 290° M at 20 to 21 knots.

At 2045, about the time of the accident, the centerfield anemometer recorded 300° M at 13 to 15 knots.

On August 16, 1987, sunset at Detroit-Metro was at 2034; civil twilight ended at 2058. At the time of the accident, the moon was below the horizon.

1.8 Navigational Aids

There were no known navigational aids difficulties.

1.9 Communications

There were no known difficulties with communication equipment or facilities.

1.10 Aerodrome Information

Detroit-Metro, elevation 639 feet msl, is located in Romulus, Michigan, about 15 miles south of downtown Detroit. The airport was certificated in accordance with the applicable provisions of 14 CFR Part 139.

Detroit-Metro was served by four runways: 3L/21R, 3C/21C, 3R/21L, and 9/27. At the time of the accident, runway 9/27 was closed because of construction and a Notice to Airmen (NOTAM) denoting its status was issued on August 10, 1987.

Runway 3C/21C was 8,500 feet long and 200 feet wide. The first 4,387 feet of runway 3C was grooved concrete; the remaining 4,113 feet was grooved asphalt, and its magnetic heading was 33.5°. Runway 3L/21R, the principal instrument runway, was 10,500 feet long, 200 feet wide, and was constructed of grooved concrete. Runway 3R/21L was 10,000 feet long, 150 feet wide, and constructed of grooved concrete. Since none of the instrument approach procedures were used by flight 255 during the accident sequence, descriptions of the procedures have been omitted.

At the time of the accident, runway 3C was being used as the primary departure runway. Runways 3L and 3R were being used for landing aircraft. Runway 3L was not available for takeoffs because taxiway Golf was closed from taxiway Hotel south to the runup area of runway 3L; however, if requested by a pilot, runway 3R was available for takeoff. In addition, taxiway Hotel was closed between taxiways Golf and Foxtrot (see figure 1) in conjunction with the runway 9/27 construction project. Notice of the closures were included in the Foxtrot, Golf, and Hotel ATIS messages.

During the accident sequence, flight 255 struck a light pole located in a rental car lot on the airport property. The light pole was 42.2 feet high and was 2,760 feet beyond the departure

end of runway 3C. Based on the applicable provisions of 14 CFR 77.23 and 77.25, the pole did not penetrate any civil airport imaginary surfaces and, therefore, did not constitute an obstruction to air navigation.

The light pole had been constructed in accordance with an approved airport layout plan as required by the provisions of Advisory Circulars (AC) 150-5300-4, 4B, Utility Airports, Air Access to National Transportation. On May 5, 1986, before the light pole was built, the airport authority requested the FAA Airspace Branch to conduct an aeronautical study of the construction proposal which included the construction of 40-foot-high light poles in the rental car lot. On June 12, 1986, the Airspace Branch completed the study and informed the airport authority that, "Based on that study we interpose no objection from an airspace utilization standpoint." However, due to the bases used to support the light poles, the poles extended 42.2 feet above the ground.

Low Level Windshear Alert System.-- At the time of the accident, a low level windshear alert system (LLWAS) was operating at Detroit-Metro. The LLWAS detects and displays the presence of possible hazardous, low-level windshears by continuously comparing the winds measured by six anemometers (sensors) located at the center and around the periphery of the airport. The Detroit-Metro LLWAS also records data generated by the system's sensors. (See section 1.18.)

The centerfield sensor is located near the geographic center of the airport. Boundary sensors are located near the approach and/or departure areas of the various runways at the north, northeast, east, south, and west sections of the airport periphery.

The LLWAS computer compares the vector components (wind direction and speed) collected by the boundary sensors with the vector components collected by the centerfield sensor. The centerfield sensor uses a tachometer to generate a wind gust input signal. The computer determines windshear magnitude by calculating the vector differences between the vector component values collected at the boundary sensors and the values collected at the centerfield sensor. When the vector difference exceeds 15 knots, the LLWAS computer initiates a windshear alarm and identifies the boundary sensor(s) where the shear is occurring.

LLWAS data are portrayed on a display in the control tower cab. The display portrays the wind data and gusts collected by the centerfield sensor continuously. The display also shows the wind direction and speed collected at each boundary sensor; however, a boundary sensor(s) wind data display is normally blanked out (unlit) unless it is involved in a windshear alarm. When the LLWAS computer generates one or more windshear alarms, an aural tone occurs at the display unit, and the wind data indicators on the affected boundary sensor(s) begin flashing. The aural warning beeps twice after the alarm occurs. The affected boundary sensor(s) continue to flash for the duration of the shear and for about 1 minute after the computed windshear alarm ceases.

The ATC recording of the local controller east (LC-E) position showed that LLWAS alarms had been received in the tower cab between 2015 and 2030 and had been broadcast by the LC-E controller over his frequency. The recording also showed that, at 2019, Northwest flight 1146 had reported a variation of plus or minus 20 KIAS between 500 and 300 feet agl while on final approach to runway 21R. ATIS Golf and Hotel were transcribed at 2020:32 and 2028:35, respectively. Both messages stated "windshear advisories are in effect."

Selection of Active Runways.--The tower supervisor has the primary responsibility to determine which runways are to be designated as active runways. Under normal circumstances, the supervisor selects the runways that are aligned closest with the wind. However, in addition to the wind direction and speed on the airport surface, the supervisor must consider the weather and wind conditions in the vicinity of the airport, weather forecasts, LLWAS indications, availability of lighting and electronic navigational aids, runway and taxiway closures, and the operational impact of the proposed change.

The tower supervisor stated that during the last 15 to 20 minutes that Detroit-Metro had been operating in the runway 21 configuration there were four or five LLWAS alarms and that he observed the wind shift toward the northwest. He stated that, about 2015 or 2020, a United Airlines B-727 reported a microburst moving from west to east with no rain associated with it. In addition, at 2019, the tower received a windshear report from an airplane on final approach to runway 21. He stated that runway 27 was closed; that a NOTAM had been issued; and that it was more advantageous to operate, winds permitting, in the runway 3 configuration. Therefore, at 2025, the tower supervisor began coordination to change from a runway 21 to a runway 3 configuration. The change was completed at 2028, and, at 2029, the instrument landing systems (ILS) were changed to the runway 3 configuration.

The guidelines for runway configuration changes by ATC personnel at Detroit-Metro are contained in tower order DTW ATCT 7110.3, dated April 29, 1981. The configuration change was completed in accordance with the subject order.

1.11 Flight Recorders

The DC-9-82 was equipped with a Fairchild model A-100-A cockpit voice recorder, serial No. 25334, and a Fairchild model F800 digital flight data recorder, serial No. 102. The recorders were taken to the Safety Board's flight and voice recorder laboratories in Washington, D.C., for examination and readout.

1.11.1 The Cockpit Voice Recorder

Except for some minor impact damage and sooting on its exterior dust cover, the CVR was in excellent condition. The recording medium was not damaged, and it had not been subjected to any excessive heating during the postcrash fire. The audio quality of the 32-minute, four-track tape was excellent. Track-1 of the tape was connected to the captain's radio/intercom panel; track-2 contained no recorded information (this track is usually connected to the flight engineer's radio control panel in a three-crewmember airplane); track-3 contained the cockpit area microphone (CAM) information; and track-4 was connected to the first officer's radio/intercom control panel.

The recording, which started at 2013:27 while the airplane was parked at the gate loading passengers and continued until 2045:24, was transcribed. (See appendix C.) The captain and first officer were in the cockpit and remained there throughout the entire recording. At 2035:35, a 0.35-second interval on the tape was devoid of any information on all four tracks; the void area was caused by a factory splice which connects the two ends of the tape to make the endless loop required for a Fairchild CVR.

While the airplane was at the gate and while it was taxiing, only the radio transmissions to and from flight 255 and between ATC and other airplanes which influenced the conversation between the captain and the first officer were transcribed. After the flight switched to the tower local control frequency, all ensuing recorded radio transmissions were included in the transcript. Flightcrew members' voices were identified by persons who were familiar with the captain and the first officer.

At 2028:53, the Northwest ramp controller cleared flight 255 for pushback from the gate. Examination of the first 15 minutes of the transcript showed that during the initial 8 to 9 minutes, the captain and first officer were occupied for the most part with mapping weather data on the company's turbulence plot. Thereafter, they became engaged in a conversation with members of the cabin crew concerning whether they would be able to arrive at Santa Ana before the local noise abatement curfew and the logistics involved in the event they were unable to leave Phoenix in sufficient time to arrive at Santa Ana before the curfew. Other portions of this transcript will be referred to herein as they become relevant to the subject under examination.

Four SSRS alarms were recorded by the CVR after the airplane lifted off. The portion of the recording containing these alarms were used to perform a sound spectrum analysis. (See section 1.16.2.)

1.11.2 The Digital Flight Data Recorder

The digital flight data recorder (DFDR) was damaged by impact forces and postaccident fire. The dust cover was dented and scraped and the frame of the recorder was deformed slightly. The fire damage was confined to sooting and there was no appreciable heat damage. The DFDR was opened and examined. The interior was clean and undamaged and the recording medium was in place on all capstans, pulleys, and guides.

Most DFDRs record up to sixty-four 12-bit words of digital information every second. Each 64-word group which is provided by the flight data acquisition unit (FDAU) to the DFDR is called a subframe, and four subframes comprise a frame. Each subframe in the frame has a unique (Barker Code) 12-bit synchronization word identifying it as subframe 1, 2, 3, or 4, and the synchronization words are the first word in each subframe. Each data parameter (i.e., altitude, airspeed, heading) is recorded in a fixed sequence within the subframe. If the data stream is interrupted, the synchronization words will not appear at the proper interval or sequence and synchronization will be lost, thus affecting the ability to decipher data in that subframe or until another synchronization word is detected.

However, the Fairchild model F800 incorporates a different recording technique. The FDAU data stream is reformatted from the standard 12-bit word to a 15-bit word. This technique, known as group code recording (GCR), replaces 4-bit nibbles with 5-bit input groups.

At the time of the accident, the DFDR was using the sixth of its six recording tracks to record data and the strength of the signal recorded on the edge tracks, tracks 1 and 6, was significantly lower than the others. Because of the lower signal strength and the fact that at the time of the initial readout the Safety Board's playback station had to reformat the recorded data from GCR to the standard 12-bit word format, the synchronization on track 6 could not be maintained at an acceptable level. As a consequence of the synchronization loss, a significant amount of data could not be deciphered and the DFDR tape was taken to the manufacturer for readout.

The manufacturer's playback equipment was able to recover the data in the GCR format, and the recovered data was of sufficient quality to perform an evaluation of the airplane's configuration and performance. However, the readouts also had a number of random synchronization losses wherein the periods of losses varied from one readout to the next. Consequently, a number of data transcriptions were accomplished in an attempt to recover all the data. As a result of these attempts, all pertinent data relating to the accident flight have been recovered.

After the initial readout at the manufacturer's facility, the Safety Board wrote a custom software package tailored to the specific requirements of this readout. The software package allowed the Safety Board to transcribe the GCR words directly. It enhanced the method of establishing synchronization by increasing the number of synchronization references. The package not only reduced the out-of-synchronization shifts in the recording, but, when these shifts did occur, the new software identified and marked the subframe in which the out-of-synchronization shift began. Using this software, the Safety Board produced a more complete readout of the DFDR's recorded data which was used to reproduce the values cited throughout this report.

The DC-9-82's FDAU receives information from the airplane's sensors, converts the sensors' inputs to digital form, and transmits the resultant signals to the DFDR where it is recorded. Flight 255's FDAU, a Teledyne Control, part No. 2222601-6, serial No. 1795, was recovered from the wreckage. It was shipped to the manufacturer's facilities in Los Angeles, California, where two separate tests were performed under the supervision of Safety Board investigators.

On September 4, 1987, a visual inspection of the FDAU found that it had been damaged slightly. Power was applied and the unit functioned normally. Thereafter, the synchronization values which affect parameters, such as flap position and pitch and roll attitudes were tested and found to have been out of tolerance. However, functional tests of the discrete signals which indicate the slat position, the flap handle disagree position, and the FMA mode parameters showed that all these discrete parameters were correct.

The first test did not develop sufficient information to quantify the extent of the FDAU's synchronization error throughout its full 0° to 360° range of values. Therefore, on December 17, 1987, a second test was conducted at the manufacturer's facility. During this test the FDAU's synchro values were evaluated at 5° increments throughout their entire range. The test showed that the 0°/360° and 180° values were within tolerance but that the error increased as the values moved away from those positions. The maximum error occurred about 45° on either side of the 0° and 180° positions. As a result of the test, correction algorithms were developed. The correction algorithms were applied to the results of the previous DFDR readouts and the values contained therein were corrected.

The corrected values were then compared to known conditions that existed during the accident flight, the landing and takeoff at Saginaw, and the landing and subsequent taxi to the gate at Detroit-Metro. To verify the corrected data, the heading, flap, and spoiler position parameters were chosen for comparison because of their predictability. The original DFDR readout showed that flight 255's heading during the takeoff run was between 27° and 28°. The corrected data show these values to be between 32° and 33° and the actual runway heading was 33.8°.

The recorded flap angles during the Saginaw takeoff indicated a setting of 9.3 transitioning to -0.336 shortly after liftoff. The corrected values show settings of 10.8° transitioning to -0.304°. Normal takeoff flap settings are 7° and 11°. The DFDR showed the following uncorrected flap positions for the landing at Detroit-Metro: 13.2°, 24.7°, 34.5°, and -0.336°. The corrected values were 15.1°, 27.3°, 39.3°, and -0.304°; detents are provided for the 0°, 11°, 15°, 28°, and 40° flap settings.

During landings, the spoilers are automatically extended to the 60° or full deployed position after main wheel spinup on ground contact or after nosegear oleo strut compression actuates the ground shift relays. The recorded left and right spoiler positions during the previous landings at Saginaw and Detroit-Metro were 51.2° and 51.8° uncorrected and 59.6° and 59.5° corrected, respectively. Examination of the above data showed that the corrected data is in closer agreement with known or expected conditions.

All recorded DFDR data cited throughout this accident report are the corrected readout values.

The airplane's pitch attitudes are recorded on two separate DFDR readout channels. Although the pitch attitude data for these channels are retrieved from the same sensory sources, the sensors are sampled separately by each channel during a 1-second interval and the data contained in the pitch attitude-2 channel is processed to a higher resolution by the FDAU than the data contained in the pitch attitude-1 channel. Examination of the readouts showed that their recorded pitch attitude values varied about 0.15° until the airplane was rotated for takeoff. During the rotation, the recorded values began separating and, thereafter, the pitch attitude-1 values exceeded the pitch attitude -2 values by 1.5° to 2.9°.

Correlation of the CVR recording with the recorded pitch attitudes showed that SSRS alarms on the CVR were more compatible with the pitch attitudes contained in the pitch attitude-2 channel.

During takeoff, the tail of the DC-9-82's will strike the runway when the airplane is rotated to about an 11.7° pitch attitude. During the 3 seconds before flight 255 lifted off the runway, pitch attitudes of about 12.4°, 13.2°, and 12.9° were recorded by the pitch attitude-1 channel, whereas, the pitch attitudes recorded in channel-2 were about 10.8°, 11.3°, and 11.3°. During this 3-second interval, the airplane would have rolled about 835 feet; however, there was no evidence on the runway of a tail strike and the tail bumper of the airplane was not scratched.

An engineering evaluation of these data indicated that the pitch attitudes contained in the pitch attitude-2 channel reflected more accurately the airplane's pitch attitudes during rotation and the subsequent flight. These values were used by the Safety Board during the subsequent airplane performance study.

The DFDR and the CVR were time correlated by comparing the radio microphone keying recorded by the DFDR with the radio transmissions from flight 255 recorded on the CVR. The correlation began at 2035:48 on the CVR and ended at 2045:19, when the sound of impact was recorded; the elapsed CVR time was 9 minutes 31 seconds. Based on the times contained on the DFDR recording, the correlation begins at 0117:14 and ends when all reliable data is lost at 0125:52; the elapsed DFDR time was 8 minutes 34 seconds. Examination of the DFDR recording showed that a synchronization loss encompassing all recorded data begins at 0124:44 (2043:18 on the CVR transcript) and synchronization was not regained until 0124:49 (2044:14.8 on the CVR transcript). At 2042:11, flight 255 was cleared into position on runway 3C and to hold. The DFDR recording indicated that the flight completed its turn to the runway heading about 2043:14, and at 2043:18, a sound of a click was recorded on the CVR transcript and the DFDR lost synchronization. At 2044:04, the local controller cleared flight 255 to takeoff and, at 2044:08, the first officer repeated the clearance. At 2044:14.8, a "sound similar to parking brake released" was recorded on the CVR's CAM followed, at 2044:21, by the "sound of increasing engine power." Examination of the DFDR readout showed that, at 0124:49 on the DFDR recording, the engine power was increasing. In correlating the DFDR and CVR, it was also necessary to take into account that on this airplane when the parking brakes are set power is removed from the DFDR and that it will not record useable data immediately upon the reapplication of power.

Examination of the recorded data from the two flights previous to the accident flight showed that, except for short time intervals when the slats were in transit to a commanded position, the flap handle position was always in agreement with the slat position.

DFDR data recorded during the taxi out and takeoff at Detroit-Metro showed that throughout the entire period the flap setting was -0.304°, the slats were retracted, and there was no disagreement between the flap handle and the slat position. During the period surrounding the loss of synchronization just before the start of the takeoff roll, the positions and values noted above were the same immediately before synchronization was lost and immediately after synchronization was regained.

The DFDR data, CVR cockpit communications, ATC communications, airplane geometry, and airport environs were integrated by the Safety Board to construct a visual depiction of flight 255's departure. The visual displays starts when flight 255 is still at the departure gate and includes the flight's pushback from the gate, taxi to runway 3C, takeoff, and initial impact. (See appendix D.)

1.12 Wreckage and Impact Information

The first object flight 255 struck after liftoff was a 42.2-foot-high light pole located in a rental car lot. The pole was about 2,760 feet beyond the departure end of runway 3C. There were no ground impact marks and no pieces of airplane structure between the light pole and the end of runway 3C. The wreckage path ran along a road outside the airport boundary and along a heading oriented essentially with the departure runway. The last major piece of airplane fuselage structure, a section of the forward fuselage containing the cockpit, came to rest about 2,980 feet beyond the light pole. Virtually all of the wreckage was found between the light pole and the forward fuselage section.

The left wing struck the light pole about 37 feet agl and, thereafter, the airplane began to disintegrate. The majority of the witnesses stated that the airplane caught fire after the left wing struck the light pole.

The nose and left main landing gears were found in the extended and partially extended positions, respectively. The right main landing gear had broken apart, and it was not possible to determine if it was extended or retracted.

Both engines had separated from their mounts during the accident sequence. The left and right engines came to rest about 3,090 feet and 2,393 feet, respectively, beyond the initial impact point. The left engine had not been exposed to ground fire, and all engine appurtenances external to the core engine had separated during the impact sequence. Most of the fan blades were bent opposite to the engine's direction of rotation.

The right engine was exposed to extensive ground fire which was fueled, in part, by ignition of the magnesium castings of the engine gearbox. All of the recovered fan blades had been bent opposite to the direction of rotation of the engine.

On August 30, 1987, a teardown inspection was conducted at the Pratt & Whitney Aircraft Group Facility, East Hartford, Connecticut. The blades on the left engine's low pressure compressor's 1.5 stage and second stage rotors and on its high pressure compressor were bent opposite to the direction of rotation of the compressors. Also, carbon deposits were found inside the engine's front accessory drive case. The blades on the second and third stages of the right engine's low pressure compressor were bent opposite to the compressor's direction of rotation.

Fuselage and Empennage. --The fuselage structure had disintegrated and was scattered throughout the wreckage path. Only two relatively large pieces of structure remained: the forward area from fuselage station (FS) 7 to FS 541 and the aft area from FS 1007 to FS 1338.

The forward fuselage section and cockpit were battered heavily and the top and upper sections broke open and tore away during the accident sequence. The cockpit area also broke open and the roof and side walls tore away. This section also had some localized burn damage.

The aft section contained the main rear wall of the landing gear well aft to the rear pressure bulkhead and the auxiliary power unit (APU). The front portion of the section was lying upright with the upper cabin section broken and burned away. The exposed cargo area was empty and gutted by fire. The APU section was not damaged heavily by either fire or explosion and the APU was relatively intact.

The empennage had broken into two major pieces. The major pieces consisted of the top 3 feet of the vertical stabilizer and right horizontal stabilizer and the base of the vertical stabilizer. These two pieces were found about 2,120 feet beyond the initial impact point.

The left horizontal stabilizer and elevator had disintegrated and pieces of these two structures were scattered throughout the wreckage site. The first pieces from the two structures were found about 650 feet beyond the initial impact point along with pieces of the left wing leading edge slat and slat support structure.

The horizontal stabilizer trim jackscrew was found mounted in position in the vertical stabilizer with the jackscrew extended. The jackscrew extension measured 9.87 inches which corresponds to a 5.65° airplane nose-up stabilizer trim setting.

Left Wing.--After striking the light pole, the left wing broke apart and pieces were scattered throughout the wreckage area. The largest intact piece, a relatively unbattered 17-foot-long section of outboard wing with most of the left aileron and outboard (No. 5) slat still attached, was found about 1,000 feet beyond the initial impact point. The slats on each wing are numbered zero through 5 beginning with the inboard slat and then moving outboard along the wing. About 19 inches of the outboard end of the No. 5 slat was broken away and the slat could be moved manually to the extended or retracted positions.

The leading edge of the separated outboard wing section was crushed aft at the point where it had separated from the inboard section of the wing. The separation line was relatively straight between the leading and trailing edges of the wing section. The fractured area included the integral fuel tank structure and was sooted and discolored by heat. Except for a 4-foot section of the outboard trailing edge which was warped, sooted, and discolored by heat, the remaining portion of the wing outboard the fuel tank had little fire damage.

The No. 4 slat had broken away from the separated wing section and an outboard section of the slat was found near the separated wing panel. The inboard broken area of the slat was crushed aft, and the location of the break and crushing aligned with the inboard separation line on the wing panel.

The remaining leading edge slats on the left wing were broken apart and their pieces were recovered throughout the wreckage area. Fourteen of the 15 left wing slat tracks were identified; the common idler track between the Nos. 2 and 3 slats was missing. The slat tracks are either drive or idler tracks. The drive tracks are connected to the slat positioning mechanism by cables and are moved by the cables to drive the slats to the commanded positions. The idler tracks are attached to and move with the slats and provide structural support to the slats. The slat tracks were examined for damage marks which may have been caused by the track rollers as the airplane broke apart.

The No. 5 slat's outboard idler track had a brinell mark that matched the diameter of the track support and guide rollers on the upper face of the lower outboard flange located about 3 1/8 inch aft of the flange's forward end. A similar brinell mark was located on the upper face of the lower inboard flange about 3 1/4 inch aft of the flange's forward end. When the rollers were aligned with the brinell marks, the position of the drive track corresponded to a fully retracted slat.

The No. 5 slat's outboard driver track was intact in the slat support assembly with the drive cables connected to the transition drum. Roller damage on the track flanges corresponded to a near full extended slat, and portions of the forward support rollers were found in the rental car lot just beyond the initial impact point. Damage on the No. 5 slat's inboard driver track was similar to that found on the outboard driver track. The No. 5 slat's common idler track which supports the Nos. 4 and 5 slats was undamaged.

The cables of the transition drum of the No. 5 slats were attached to the drum, and there was no slippage around the drum groove. The cables were continuous from the drum to the separation point on the outboard wing section. When the drum was positioned to extend the slats

to their full extend position, the breaks in the forward and rear cables were misaligned 15 1/2 inches. This misalignment placed the forward cable fracture point outboard the wing separation point (inside the wing structure) and the rear cable fracture point inboard the wing separation line. When the cables' fracture points were aligned, the fractures also were aligned with the wing separation point and the slat tracks would have positioned the slats in the full retracted position. Also, application of tension on the rear cable moved the slat tracks toward the slats extended position.

The brinell marks on the Nos. 3 and 4 slat driver tracks corresponded to the slats being extended fully. The remaining slat tracks did not have notable damage.

The slat drive mechanism located in the center wing section separated from the airplane; however, the slat drive drum and its two actuators were recovered in one piece. The actuator rod on the left side was broken, but the actuator rod on the right side was intact. The actuator rod for the right actuator was almost fully retracted and measured about 4 inches between the centerline of the rod attachment bolt and the raised center area on the actuator's face. According to McDonnell Douglas, the measured distances between these two points for the slat retracted and the mid-sealed position were 3.6 and 9.6 inches, respectively.

The inboard and outboard trailing edges flap sections were torn from the left wing and destroyed. The two actuators of the inboard flap section remained attached to a 16-foot-long inboard section of the left wing which was found about 2,800 feet beyond the initial impact point. When first examined, both actuators were extended 16.3 inches when measured between their attachment point to the airplane structure. However, the inboard flap sections of the two actuators exhibited a dirt pattern on both the actuator housing and the rod end with clean piston rod exposed between the housing and rod end. When the actuator rod was positioned so that the dirt areas were continuous, the actuator measured 13 inches between its attachment points. This measurement corresponds to the flap retracted position.

The inboard actuator from the left outboard flap section exhibited a dirt pattern similar to that described above. The actuator measured 13 inches between attachment points when the dirt areas were continuous which corresponded to a full retracted flap position. The outboard actuator of this flap section was not found.

The left flap track assembly, which was relatively intact and undamaged, was still attached to the inboard end of a section of left inboard flap. A 1 3/4-inch-long dent was found on the inside surface of the track flange about 1 1/4 inches forward of the track's aft end. The size and shape of the dent matched the size and shape of the carriage rollers which ride along the inside of the flange and the location of the dent corresponded to the flap retracted position.

Examination of the flaps, the flap hydraulic system, and the actuators disclosed that the integrity of the flap hydraulic system was destroyed and that the actuators' plumbing was open to the atmosphere.

Right Wing.--The right wing was destroyed by impact forces and postimpact fire. Pieces of the wing structure were scattered throughout the wreckage path. The largest piece of wing structure, an 18-foot-long inboard wing section, came to rest about 2,700 feet beyond the initial impact point. A section of the inboard and outboard trailing edge wing flaps was still attached to the wing section by three of the four flap actuators and their respective hinge attachment points. The fourth flap actuator, the right inboard flap section's inboard actuator, was attached to fuselage structure. A section of the leading edge slats also was attached to this wing section by five track attachment points. The slat section was in one piece. It was burned heavily, discolored by heat, and could be moved manually from the extended to the retracted position.

Fourteen of the 15 slat tracks were found; the No. 1 slats inboard idler track was not found. Only two of the 14 tracks had notable marks. The No. 4 slat drive track had brinell marks at a position which corresponded to a fully extended slat. A small section of the No. 3 slat drive track was broken away at a position which corresponded to a fully extended slat.

The right inboard flap section's inboard actuator (No. 1) measured 17 7/8 inches between attachment points, and the rod was sooted evenly. The inboard flap section's outboard actuator (No. 2) was attached to the wing and flap structure as were the outboard flap section's inboard (No. 3) and outboard (No. 4) actuators. The Nos. 2 and 3 actuators measured 13 1/2 inches between attachment points. The No. 4 actuator measured 14 3/4 inches between attachment points; however, sooted and clean areas were found on the piston rod. There was a 1 5/16-inch clean area between the actuator housing and the start of the sooted area on the rod end of the piston rod. A measurement of 13 inches between the actuator attachment points corresponded to the flaps retracted position.

The right flap track assembly had separated from the flap structure but was recovered intact. The track assembly damage was similar to the left flap track assembly. The track flange was damaged about 3/4 inches from the aft end of the flange and about 2 3/8 inches of the flange was torn away. The size of the damage matched the size of the track carriage rollers, and the location of the damage corresponded to the flap retracted position.

The Cockpit.--The position of the cockpit controls and indicators were fully documented. The following pertinent observations are listed herein.

The ART switch was in the automatic position, and two zeros were showing in the TCI's assumed temperature window indicating that normal takeoff power was to be used.

The throttles were found in the full forward positions.

The TCC had 10.1 percent inserted in the c.g. window; 9.7° appeared in the longitudinal trim setting window; the stabilizer green band was at 8.5° airplane nose-up; and the stabilizer was set at 8.5° airplane nose-up. The position of the TCC flap setting thumbwheel could not be established during the on-site investigation because the wheel had broken away in the area of the pedestal window. When the unit was examined more closely at the Douglas facility in Long Beach, portions of the wheel were found intact within the unit. Interpolating between the two nearest numbers on the remaining portions of the thumbwheel established that it was set at 11°.

The annunciator pull-to-dim switch on the overhead switch panel was in the dim position and the switch stem was bent aft.

The flap handle was in the UP/RET detent and the dial-a-flap movable detent assembly was stowed. The cockpit control pedestal containing the flap handle and the flap and slat selection mechanisms was removed for teardown and detailed inspection. The following systems and parts of airplane structure were removed for further detailed examination (see section 1.16): numerous circuit breakers, the CAWS unit, portions of the cockpit instrument and annunciator panel and warning light systems, the DFGC, the stall warning computers, the central air data computers (CADC), and the proximity switch electronics unit (PSEU).

1.13 Medical and Pathological Information

The postmortem examinations of the captain and first officer determined that their deaths were caused by severe blunt force trauma. No evidence of preexisting disease processes were noted.

Toxicological tests conducted after the postmortem examinations were negative for drugs and alcohol. There was no evidence that indicated either pilot was using prescription or nonprescription medication either at or before the time of the accident.

The captain sometimes wore an "in the canal" hearing aid in his left ear which was adjusted for high frequency emphasis. The captain's wife stated that she and some friends had encouraged him to purchase the hearing aid not because of conversational difficulties but because he required the television to be tuned to higher volumes than others would require.

The captain was examined for the hearing aid by a private firm on September 8, 1986, and the evidence indicated that he received the aid on September 24, 1986. On April 22, 1987, the captain passed his first class FAA physical examination. The medical certificate did not contain any remarks concerning his using a hearing aid nor did it contain any remarks requiring him to use the aid while exercising his airman's privileges. During the examination, his hearing was evaluated by "whispered voice, standing sideways, distant ear closed." The medical examiner concluded that the captain could hear the whispered voice satisfactorily at a distance of 20 feet with both his left and right ears. Friends and crewmen with whom he had flown stated that they had no difficulties communicating with him.

With regard to the first class medical examination, question No. 21 on the medical form (FAA Form 8500.8, dated 10- 75) requires the applicant to supply his medical history to the examiner. None of the 24 conditions requiring an answer in question No. 21 addresses either a hearing loss or treatment for hearing problems, and the captain did not mention his hearing evaluation under question No. 23 which asks the applicant to describe any "Medical Treatment Within Past 5 Years."

External examination of the other airplane occupants showed that all had sustained multiple injuries. According to the Wayne County Medical Examiner, autopsies of the victims were not performed in view of obvious injuries which caused instantaneous death. The medical examiner stated that 10 percent of the victims "sustained burns and all fire injuries were post mortem." The survivor, a 4-year-old female child, sustained third degree burns, a skull fracture, fractures of the left femur and clavicle, and multiple lacerations, abrasions, and contusions.

1.14 Fire

The DC-9-82 caught fire after its left wing struck the light pole. The postimpact fire contributed to the destruction of the airplane.

1.15 Survival Aspects

The DC-9-82 was configured for a two-person flightcrew and 143 passengers. The passenger cabin was configured with 12 first class passenger seats: three rows of double seats on the left and right sides of the cabin. The 131 tourist class seats, including a designated flight attendant seat (29D) consisted of 28 rows of triple seats on the right side and 24 rows of double seats on the left side of the cabin. A double occupancy aft facing flight attendant seat was on the aft left side of the cockpit rear bulkhead; a double-occupancy forward facing flight attendant seat was located on the ventral airstairs aft exit door.

The wreckage was distributed over a 3,000-foot crash path which traversed a railroad embankment and overpass and two interstate highway overpasses. Except for two fairly large fuselage sections, the cabin area disintegrated during the crash sequence. The cabin components were deformed severely and fragmented by the impact forces. Most of the interior components were damaged to varying degrees by fire. The main entry door, the rear galley and ventral doors, and the overwing emergency exits were separated from their frames. All of the passenger seats

were separated from the fuselage and were scattered along the wreckage path. Most seatbacks were separated from the seat bottoms.

The left side of the cockpit was destroyed. The left and right side sliding windows were deformed and separated from the cockpit structure. The windshield and side windows were found along the wreckage path. The captain's and first officer's seats separated during the impact sequence.

The survivor was found in the wreckage beneath one of the highway overpasses. According to the company's passenger manifest, she had been assigned seat 8F.

1.15.1 Crash, Fire, Rescue

Detroit-Metro airport fire department operates in accordance with Crash, Fire, Rescue (CFR) Index E contained in 14 CFR 139.49(b)(5). ^{9/}

At 2046, the airport fire department was notified of the accident by the local controller in the tower, and all available CFR equipment was dispatched and proceeded to the accident scene. At the same time, a unit of the Wayne County's Sheriff's Department notified its communications dispatcher that an airplane was down at Middlebelt and Goddard Roads. Another sheriff's department unit responded, took command of the scene, and called for all available units to assist at the site.

At 2049, airport fire department personnel arrived at the scene about 2 1/2 miles from Fire Station 1 and began to fight the fires. At the same time, two units from the Romulus Fire Department arrived at the highway overpass where the cockpit wreckage was located and began rescue and firefighting operations. About 36,000 pounds of Jet-A fuel were on board the airplane when it crashed.

A major command post was established at the sheriff's department about 2 miles from the crash site and a mobile command post was established at the site. Other fire departments, affiliated through the Western Wayne County Mutual Aid Agreement, reported to the scene as required by the agreement. At 2102, after extinguishing localized fuselage and spot fires, firefighting efforts were ended. A total of 19,908 gallons of water and 775 gallons of aqueous film forming foam (AFFF) were expended by the airport fire department; 3,075 gallons of water were expended by the Romulus Fire Department.

At 2050, Detroit-Metro issued a NOTAM stating that the airport was closed. At 2115, the previous NOTAM was canceled, and, in accordance with 14 CFR 139.89(c), a second NOTAM was issued stating that the airport was below (the Part 139) index without specifying which index. At 2400, a third NOTAM was issued canceling the 2115 NOTAM and advising that the CFR equipment was back in service. There were 75 air carrier operations at Detroit-Metro during the period that it was below the CFR index.

Police Response--The Wayne County Sheriff's Department responded with all available personnel. After evaluating the crash scene, the Sheriff's Department notified the Michigan State Police and surrounding police departments. About 40 police departments

^{9/} The applicable CFR index in 14 CFR 139.49 is determined by the longest large aircraft operated by an air carrier user with an average of five or more departures per day, served or expected to be served by the airport. Index E applies to aircraft more than 200 feet long.

Michigan State Police and surrounding police departments. About 40 police departments volunteered personnel and equipment. Surrounding police departments were assigned to maintain site security and to control traffic.

Medical Response --At 2054, the Health Emergency Medical Services, Inc. (HEMS), an independent corporation contracted by area hospitals to dispatch emergency medical services, was notified. After verifying the alert, HEMS notified personnel to staff the emergency operations center at the sheriff's department. At 2102, the HEMS dispatcher began alerting hospitals of the accident; 11 were alerted. At 2110, the dispatcher polled all hospitals for a bed count, however, at 2140, the command post at the accident site notified HEMS that there were no additional survivors. At 2204, HEMS secured its disaster plan and notified its member hospitals.

1.15.2 Disaster Plans

Detroit-Metro Emergency Plan met the requirements of 14 CFR 139.55. The airport's last FAA annual inspection was completed satisfactorily on April 7, 1987, and its last airport disaster drill, a simulated major airplane crash, was conducted on September 11, 1985.

On March 4, 1987, Detroit-Metro's fire department responded to an actual disaster when a commuter air carrier's CASA 212 airplane crashed and burned at concourse F on the airport.

During May 1987, HEMS, in conjunction with fire departments and private ambulance services, conducted a disaster drill in which a simulated tornado struck an elementary school.

1.16 Tests and Research

1.16.1 The CAWS Unit

N312RC's electrical and electronics (E&E) compartment was found virtually intact in the wreckage path. The CAWS unit, serial No. 131, was removed from the E&E compartment and taken to Northwest's maintenance facilities at Minneapolis. On August 27 and 28, 1987, it was examined by the Safety Board's system group.

Except for a dent in the top left corner of the dust cover, N312RC's CAWS unit was undamaged. The dust cover was removed, the interior inspected, and all of the circuit boards appeared to be intact. Another CAWS unit, serial No. 61, was drawn from Northwest's stores, placed on Northwest test equipment, and subjected to a complete test procedure. The test results showed that the CAWS was operational. Thereafter, the five circuit boards from the accident CAWS were substituted in the test CAWS and a functional test was performed with each circuit board; the results were satisfactory. Each of the three power supplies in the accident CAWS' empty chassis were then tested and proper operation of the power supplies were verified. The original circuit boards were then reinstalled in the accident CAWS unit and a full acceptance check was performed; no discrepancies were noted.

The accident CAWS unit was then installed on another Northwest DC-9-82, N309RC, after proper operation of the existing CAWS unit had been verified. All takeoff warning functions were tested repeatedly and no discrepancies were found. The stall warning, fire warning, and stabilizer-in-motion horn also were tested repeatedly; no defects were noted.

Since activation of the takeoff warning is a function of the throttle lever angle and not power setting, the amount of movement required to trigger the warning was measured between the idle stop and the aft face of the throttle lever, at the level of the pedestal. Measurements of 1 13/16 and 1 15/16 inches were obtained for the left and right throttles, respectively, and produced a throttle split of about 2/3 of a throttle knob diameter. The measurements obtained were slightly

reference stabilized power setting for activation of the takeoff warning system. With a field elevation of 840 feet msl, a temperature of 62°F, and an altimeter setting of 30.18 inHg, the engine EPR was 1.44 with the No. 2 throttle set at the position at which the takeoff warning activated.

While the accident CAWS unit was installed in N309RC, the system's two SSRs were tested. The results of the test were recorded on N309RC's CVR for future sound spectrum analysis at the Safety Board's audio laboratory. The recordings were made with all three CAWS unit power supply circuit breakers closed and then with each circuit breaker open in turn. The circuit breaker panel locations of the circuit breakers and their affected CAWS power supply and warnings were:

- Circuit breaker U-31, power supply-1 with overspeed, engine fire, and horizontal stabilizer warnings, and the evacuation signal.
- Circuit breaker P-40, power supply-2 with the SSR-1, landing gear, takeoff, autopilot disconnect, cabin altitude, and speed brake warnings.
- Circuit breaker R-41, power supply-3, with the SSR-2 and altitude alert warnings.

The results of the tests indicate that when the stall warning test switch was activated with all three power supply circuit breakers closed, both CAWS speakers operated, both stall warnings were heard with the processor controlled (primary) audio stall warning on the left speaker and the redundant audio stall warning on the right speaker (see section 1.16.2, sound spectrum analysis), and both the captain's and first officer's stall warning lights illuminated. With the U-31 circuit breaker open, the results were identical.

When the stall warning test switch was activated with circuit breaker P-40 open, both speakers operated, only the audio alarms generated by the SSR-2 was heard on both speakers, and only the first officer's stall warning light illuminated. When the test switch was activated with circuit breaker R-41 open, the audio alarm generated by the SSR-1 was heard on the right speaker, the left speaker did not operate, and only the captain's stall warning light illuminated. In addition, there was no combination of open CAWS power supply circuit breakers that would cause the "CAWS Fail" light to illuminate.

The captain's and first officer's stall warning light bulbs from the cockpit glare shield were taken to the Safety Board's material laboratory for filament analysis. The cover plate had been knocked from the captain's stall warning bulbs, but the bulbs were not broken. There was no significant stretching damage noted on the filaments from either bulb.

The glass from the first officer's right stall warning bulb was broken but the left bulb was intact. The base of the broken bulb was removed from its housing, thereby freeing the broken pieces of bulb glass. The major portion of the bulb filament was broken off and found lying in the glass debris. Examination of the filament piece showed stretching, typical of an impact while the filament was hot, on various portions of the filament length. Examination of the filament of the undamaged bulb showed that it also contained some localized stretching.

1.16.2 CAWS Sound Spectrum Analysis

Three recorded tapes of the audio warnings generated by the CAWS unit's two SSRs were used by the Safety Board's audio laboratory to perform the sound spectrum analysis. The first tape was recorded by the accident airplane's CVR during the accident flight. The second was recorded on August 28, 1987, as described in section 1.16.1. The third tape was made on October 1, 1987, by connecting the recorder to the CAWS unit's audio outputs.

The CAWS stall warning system's vocabulary was obtained by electronically digitizing a female subject's voice saying the words of the warning. These words were then stored in the CAWS' memory chips. The normal stall warning consists of four aural alert tones followed by the word "stall."

The two stall words spoken by the CAWS for the primary and the redundant stall warnings are different. Although they were both produced by the same subject and digitized using similar methods, two different samples were chosen for each warning system. The primary system word, which is generated by SSRS-2 and power supply-3, has a very limited fundamental frequency range and, therefore, a flat, almost monotonous pitch. Its frequency range is only 42 hz wide, ranging from a high frequency of 471.15 hz at the start of the word to a low frequency of 427.88 hz at the end of the word. The duration of the word is about 0.37 second. When seen on the sound spectrum analysis chart, the word produces a level spectrum signature.

The redundant warning, which is produced by SSRS-1 from power supply-2, is much more dynamic in frequency. Its frequency range is about 168 hz wide, ranging from a high frequency of 586.54 hz at the start of the word to a low frequency of 418.22 hz at the end of the word. The duration of the word is about 0.32 second. When seen on the sound spectrum analysis chart, the word produces a descending diagonal stroke signature. Each of the two "stall" words has a unique sound spectrum signature. Examination of the sound spectrum analysis chart made from the CVR recording of the accident flight showed that the the word "stall" produced a flat, level spectrum signature. A comparison between the spectrum analyses made from the test runs and those made from the accident flight CVR recording shows that the stall warning given on the accident flight was the primary system only, i.e., it was produced by SSRS-2 which was operated by power supply-3. There were no frequency components of the redundant "stall" word present in any of the warnings issued by the CAWS on the accident CVR.

1.16.3 Electronic Equipment

Numerous components were recovered intact from their racks in the E&E compartment and later subjected to standard bench test procedures. These components included both DFGCs, both CADCs, both stall warning computers, the FDAU, and the PSEU. Except for the FDAU and the DFGCs, none of these units exhibited any evidence of discrepancies that would have affected its normal operation during the standard bench test procedures.

The examination of the FDAU indicated that the synchronized signals were out of calibration. Additional data was obtained from the manufacturer and the signals were recalibrated. (See section 1.11.2.)

The memory readout of both DFGCs revealed the presence of a "flap handle failure" message on nearly every flight segment stored in the memories. The DFGCs will log this message if the flap handle position differs from the flap position by more than 3°, or if a synchronization leg has failed. However, it was established that a discrepancy resulting in this failure message would not affect the mechanical operation of the flaps nor the proper functioning of the takeoff warning system. The DFGC memories would also log faults detected in the angle of attack signal, various CADC parameters, flap position signals, the ground sensing system, and slat position. None of these faults appeared in either of the accident airplane's DFGCs' memories.

1.16.4 Cockpit Wiring and Circuit Breakers

Except for the wiring of the microswitches on the throttles which were damaged by impact forces, the takeoff warning system's wiring between the control pedestal's mating connectors and the CAWS was intact and undamaged. The wiring and switches in the pedestal, including the stabilizer and flap takeoff setting switches, were tested at the McDonnell Douglas

facility at Long Beach; no discrepancies were noted. The wiring between the PSEU and the CAWS also was intact and undamaged, as was the wiring from ground through the R2-5 relay contacts to the CAWS rack. The R2-5 ground sensing relay was tested and found to be functional. The left ground shift circuit, which controls the R2-5 relay, was electrically intact; however, the left ground shift switch, which is located on the nosegear oleo and supplies liftoff information, was missing.

The CAWS speakers were wired correctly to the connectors in the cockpit console and the wiring was intact. Damage to the speaker wires precluded determining their condition between the console connectors and the FS 110 junction box; however, the wires were intact and undamaged between the junction box and the CAWS rack. The P-40 circuit breaker was broken free of the circuit breaker panel and the bus, but both of its circuit wires remained attached to the remnant of circuit breaker by the terminal hardware. The bus terminal had broken free from the breaker housing and remained attached to the left 28V d.c. bus. The wiring between the breaker and the CAWS rack was intact and undamaged. The other wire of the P-40 circuit breaker which connects to the landing gear lever relay was shorted to ground on the initial test, but after the position of the wire was changed, the electrical short indication ceased. Visual inspection of the wire disclosed a small chafed area in the wire's insulation about 9 inches from the circuit breaker's terminal. A microscopic inspection of the chafed area revealed no evidence of electrical arcing or shorting on the exposed wire.

The P-40, type 7274-55, circuit breaker was manufactured by the Klixon Division of the Texas Instruments Corporation ("7274" identifies the type circuit breaker; "-55" identifies the airplane manufacturer). The investigation disclosed that McDonnell Douglas had issued three All Operator Letters (AOL) concerning operator-reported problems with the 7274 series circuit breaker: AOL 9-1281, April 4, 1981; AOL 9-1281A, November 22, 1982; and AOL 9-1281B, January 14, 1983. The AOLs state that the most common of the reported failure modes was an "open circuit, however, externally, the circuit breakers would appear to be closed." The reported problems appeared to be related to circuit breakers manufactured between January 1979 and November 1980. The AOLs stated that the causes of these failures included:

- Broken lower contactor spring members. Because of design differences, this is confined to circuit breakers rated at less than 7.5 amperes. The problem is apparently related to circuit breakers that are functioned manually, making and breaking circuits. The repeated cycling causes the spring member to break.
- Internal insulator hanging up. The manufacturer indicated this is related to circuit breakers containing a warped case half which was not detected at inspection.
- Bimetallic element hang up. This problem is due to undetected assembly operation weld splatter within the case.

Douglas reviewed the circuit breaker failure data of two DC-9-80 operators and also analyzed its rejection history on in-house problems. The results of these actions indicated that the Klixon circuit breakers rejection rate was about 1/2 of 1 percent, which according to Douglas "constitutes an acceptable quality level of rejections . . ." The rejection rate also paralleled that of two other manufacturers.

Douglas also drew from existing stock a random sample of 315 circuit breakers of the 1- through 10-ampere rating of the affected 1979 and 1980 date codes and subjected them to a "Douglas monitored intensive test program at Klixon. Not one of these circuit breakers failed the tests." AOL 9-1281B states, "Douglas feels that there is no definable problem with these particular

circuit breakers other than the possibility of experiencing an unannounced open of the circuit breaker due to the contacts hanging up."

Numerous circuit breakers, in addition to the damaged P-40 circuit breaker, were removed from the wreckage. Seventy date codes were positively identified, and all but three (dated June 1981, December 1981, and June 1982) were found to be within the manufacturing time interval designated in the AOLs. The 67 circuit breakers that fell within the date code, as well as other circuit breakers that were relatively intact but had illegible date codes, were removed from the airplane and taken to the Klixon facilities in Attleboro, Massachusetts, for further examination. None of the 69 circuit breakers exhibited mechanical or electrical continuity problems, but some particulate matter was found randomly in some of the devices. The observed condition of their internal components was commensurate with expected service conditions.

The impact-damaged P-40 circuit breaker was taken to the Safety Board's materials laboratory for further examination. The circuit breaker housing was broken when received, and the portion containing the reset mechanism was missing. The breaker's bimetallic strip and one of the terminals were contained within the remaining housing structure. In addition, the terminal attached to the circuit breaker panel bus bar also was recovered. Examination of the circuit breaker's contacts under high magnification indicated that three of the four contacts were clean. The fourth contact that was connected to the bus bar that had separated from the breaker had dark tarnish film on the outer perimeter. Electric resistance testing of the surfaces on the three clean contacts showed good electrical continuity. However, there was some intermittency on the outer area of the film on the bus bar terminal contact when tested with a 1.5 volt probe. In addition, the examination did not disclose any evidence of the anomalies cited in the Douglas AOLs.

According to Klixon personnel, the tarnish on the P-40 circuit breakers bus contact appeared to be typical of a silver sulfide buildup that can occur on the contacts of the breakers during normal service. A chemical analysis of the contact at the Safety Board's materials laboratory using x-ray energy dispersive spectroscopy (EDS) indicated that the surface of the contact was rich in silver. EDS of various areas of the contact revealed the presence of small amounts of (in decreasing order) silicon, sulphur, copper, zinc, iron, calcium, and aluminum, in addition to a large amount of silver. Further probing of the surface of the contact with a higher voltage probe than used earlier (22V versus 1.5 V) revealed that the sulfide was conductive. Some of the contacts on the other 69 circuit breakers also had a silver sulfide tarnish buildup. However, the tarnish buildup on the bus bar contact of the P-40 circuit breaker was among the heaviest of all the contacts examined.

An examination was conducted at the Klixon facilities, on another 19 CAWS circuit breakers that were removed from the Northwest DC-9-82 fleet and subjected to test. After removal from the airplane, each circuit breaker was subjected to no more than 10 cycles in a mocked up circuit representative of the CAWS input circuit. Three circuit breakers did not conduct current when the latching mechanism was closed after several cycles, and another exhibited intermittent conductivity which could not be duplicated. An X-ray examination of the three nonconducting circuit breakers disclosed that the contacts appeared to be closed.

The initial test on the three nonconducting breakers was a continuity check in a circuit representative of the CAWS input circuit. Two of the breakers remained in the nonconductive state, while the third conducted current in the circuit and exhibited continuity with a 1.5 volt continuity tester. Windows were then milled in the cases of the breakers so that the contact areas could be observed, and the continuity of the breakers was tested again. It was found that another of the breakers conducted current with both 28 and 1.5 volts applied. At this point, one breaker remained electrically open even though the latch was closed and the contacts appeared mated, and two others, that had originally been nonconducting with the latch closed, now conducted current.

Further examination disclosed that the contacts of the open breaker were held apart by particulate matter that was comprised chiefly of silicon. Examination of the stationary contacts of the now-closed breakers revealed the presence of silver sulfide tarnish. Continuity tests with 28 volts revealed that the surface of the contact was conductive, but probing with a 1.5-volt tester disclosed areas of intermittent conductivity on the stationary contact surfaces of the now-closed breakers. These results are similar to the behavior of the tarnished bus bar contact of the P-40 circuit breaker from flight 255.

Examination of the contacts of the circuit breaker that was removed from service and exhibited intermittency that could not be duplicated revealed the presence of black particulate matter on one stationary contact. Additionally, one circuit breaker that was removed from service had a stationary contact that had areas of intermittency around the periphery of the contact surface. The breaker behaved normally during the 10-cycle bench test described earlier.

1.16.5 Flap Handle Module

Following the accident, the flap handle module was examined at Douglas' Long Beach facilities and at the Safety Board's materials laboratory. The right side of the flap handle module had been displaced to the left, causing permanent deformation. The flap handle's pivot shaft supports were broken and the handle and dial-a-flap movable detent had been displaced downward. As a result of this displacement, the dial-a-flap pin on the right side of the flap handle rested between the cam finger and the movable detent. The left side of the flap handle was contacting the fixed detent track, and the fixed detent pin was found in the UP/RET position. The left side detent track was neither deformed nor moved from its normal mounted position.

The module was disassembled and examined for damage associated with the detent pins on each side of the handle. On the right side of the module, the stowed dial-a-flap mechanism had gouge marks on the side of the cam finger which were consistent with abnormal contact with the end of the dial-a-flap detent pin. This pin contact damage continued onto the forward lobe of the stowed movable detent. The damage areas on the cam finger and on the movable detent were located in line with and just below a position on the cam finger that would correspond to the UP/RET position of the flap handle. Examination of the end of the dial-a-flap pin revealed damage on one side of the pin end that was consistent with sliding contact damage of the type described above.

On the left side of the module, an examination of the fixed detent track revealed a heavy contact area in the bottom of the UP/RET position. This area contained a circular imprint and associated sliding damage caused by contact with the end of the fixed detent pin. A raised lip of metal found around most of the pin end corresponded to the distinct circular impression found in the detent track. No unusual damage was found in any of the other detent positions on this track.

1.16.6 Airplane Performance

The Safety Board's performance study was based on data derived from the airplane's DFDR, CVR, and time-correlated DFDR and CVR information.

Based on the airplane's final weight tabulation and the information contained in the company's dispatch papers, the airplane's takeoff weight was 144,047 pounds and the flap and slat settings to be used for takeoff were 11° and mid-sealed position, respectively. The position of the TCC flap setting thumbwheel further corroborated the intended 11° takeoff flap setting. The takeoff speeds on the Northwest takeoff card for that weight and configuration were as follows: critical engine failure speed (V1) was 142 KIAS, rotation speed (Vr) was 144 KIAS, and V2 was 153 KIAS. The minimum speeds for flap and slat retraction were 158 KIAS and 198 KIAS, respectively.

The performance study's computations were based on the following data: takeoff weight--144,000 pounds; c.g.--10 percent MAC.; runway elevation--631 feet msl; runway gradient to liftoff--0.05 percent down; altimeter setting--29.85 inHg; surface winds--300° at 14 knots; and the temperature at the time of takeoff--79° F. (The temperature in the last ATIS message was 88° F.)

The DFDR data indicated that the takeoff was made with the airplane's trailing edge flaps and leading edge slats retracted. The DFDR data also indicated that both engines were operating at or above takeoff thrust until all recorded data were lost.

The reconstruction of the actual takeoff showed that the airplane's acceleration up to and through V_r was in accordance with predicted rates. The first officer called both V_1 and V_r , and these callouts were consistent with the computed values cited above. The airplane began to rotate at V_r . Assuming proper takeoff configuration, the DC-9-82 normally will liftoff between 6° and 8° noseup pitch; however, in this case the airplane did not. The airplane continued rotating until it reached a 11° to 12° pitch angle and stabilized at that angle. (The DC-9-82's tail will strike the ground at a 11.7° pitch angle. There was no evidence that a tail strike occurred.)

The airplane lifted off the runway at the 11° to 12° pitch angle as it was accelerating through 158 KIAS. The computed flaps and slats retracted stall speed for the airplane was 170 KIAS. The stall warning system's stick shaker activated 0.5 second after liftoff and continued to operate until the end of the CVR tape. The airplane continued to accelerate after liftoff and began to climb. At 4.5 seconds after liftoff, when the airplane was over the departure end of the runway at 10 feet agl, the SSRS aural alarm activated. There were three more SSRS activations before the initial impact; these occurred about 6, 9, and 12 seconds after liftoff. During the 14 seconds between liftoff and initial impact, the DFDR data indicated that the airplane climbed about 45 feet and accelerated to about 186 KIAS.

According to Douglas' manager of aerodynamics and acoustics for the DC-9 and DC-9-80 programs, the roll stability is decreased significantly when the airplane is flying near its stall angle of attack. "It can be flown there, but it's a very difficult thing to do." The recorded data showed that, about the time of the first SSRS alarm, the airplane began a slight roll to the left which was reversed when a bank angle of about 8° was achieved. The airplane then rolled right about 16°, left about 33°, right about 35°, and then left; and initial impact occurred about 22° left roll as the airplane was rolling to the left. The data showed that the spoilers were used to counteract these rolls and that on two occasions almost full deflection (60°) was employed. The recorded elevator control data also indicated that the pilot had applied down elevator at the onset of each SSRS alarm followed by an up elevator input as the alarm ceased.

Except for momentary nose-down corrections, the pitch angle continued increasing throughout the flight until it reached between 14° and 15°. Stick shaker activation was continuous and there were intermittent SSRS activations. The programmed angles of attacks for stick shaker and SSRS activation were about 11° and 13°, respectively, and, in this case, the angles of attack and the fuselage pitch angles were about the same. Although the airplane was being flown at angles of attack between those that activated the stick shaker and the SSRS, it was still accelerating and climbing. However, the airplane's aerodynamic performance in this area was reduced by two factors: the rolls and the spoiler deflections used to counteract the rolling moments. During the last 6 seconds of the flight, the roll oscillations and subsequent spoiler deflections adversely affected the airplane's climb performance by degrading the lift component by as much as 20 percent.

The deployment of flaps and slats on a wing increases its lift capability and reduces its stalling speed. In this case, the I-G stall speed for the clean wing was 170 KIAS. Extending the slats to the mid-sealed position would reduce the stall speed 40 KIAS; extending the flaps to 11° would have reduced the stall speed an additional 6 to 8 KIAS. The reduced stall speeds would have reduced the airplane's liftoff speed, reduced its takeoff ground roll distance, improved its climb capability, increased its climb angle, and improved the roll stability. Given these data, the Safety Board explored six climb profiles.

The first profile reflected the airplane's performance with the flaps at 11°, the slats at the mid-sealed position, and the takeoff performed at programmed speeds contained on the company's 141,000-pound takeoff chart. Under these conditions, the airplane would have lifted off 6,520 feet down the runway and cleared the initial impact point by 600 feet. (See figure 2.)

The second profile reflected the airplane's performance with the flaps retracted, the slats at the mid-sealed position, the takeoff performed at the programmed speeds above, and the pitch angle during the climb as required to maintain a $V_2 + 10$ KIAS climb. The resulting performance was virtually identical with the first profile. (See figure 2.)

The third profile was the same as the second except that the pitch angle after liftoff was maintained at 15° nose-up and the airplane was allowed to accelerate beyond $V_2 + 10$ KIAS. In this case, the liftoff distance was the same and the airplane would have cleared the impact point by 400 feet. (See figure 2.)

The fourth profile depicts the performance of the airplane with flaps and slats retracted. The airspeeds, pitch, and roll attitudes of the airplane were based on values derived from the DFDR readout of the takeoff roll. The profile placed the airplane at 41 feet agl at the impact point. (See figure 2.)

The fifth profile was based on a performance study which assumes that the captain used the stall recovery procedures contained in the APH. (See section 1.17.2.) The study was based on the values derived from the DFDR readout of the takeoff roll, liftoff, and the flightpath of the airplane until 3 seconds after the initiation of the stick shaker. The study assumes that the captain recognized that his airplane was approaching a stall 3 seconds after the stick shaker activated, and, in accordance with the procedures contained in the APH, called for maximum power, called for the flaps to be extended to 15°, and relaxed the back pressure on the control column to stop the stick shaker. Based on the delays required for the engines and the flaps and slats to respond to the power and control inputs, the study indicated that the airplane would clear the light pole by about 350 feet. However, any delay in recognition and reaction time would reduce the margin of clearance.

The sixth profile reflected the airplane's performance with the wing flaps and slats retracted and maintaining an 11° angle of attack, i.e., at or just below the stick shaker activation. In this case, the airplane would have cleared the light pole by 80 feet.

The Safety Board's systems group used the DFDR data to simulate the performance of the airplane's F/D during the accident takeoff and to reproduce the visual cues provided to the captain by the system's command bar. The visual cues presented by the command bar are superimposed on the presentation provided by the airplane's attitude director indicator (ADI). Thus, the pilot can relate the command bar clues to the actual attitude of the airplane depicted on the ADI by the position of the fixed airplane symbol relative to the ADI's horizon reference bar and pitch ladder. The pitch ladder consists of four lines below and four lines above the horizon reference lines. The lines are parallel to the horizon reference line, they are spaced to portray 5° intervals, and, the resultant ladder depicts 20° of either nose-up or nose-down airplane pitch attitude.

MODEL MD-80
JT8D-217
ESTIMATED TAKEOFF FLIGHT
PATHS FOR SEVERAL
CONFIGURATIONS

| PATH | TAKEOFF | CONFIG | SPEED REF | TARGET PITCH |
|------|--------------|---------|-----------|--------------|
| 1 | NORMAL | 11°/MED | 11°/MED | AS 800 |
| 2 | ABUSED | UP/MED | 11°/MED | AS 800 |
| 3 | ABUSED | UP/MID | 11°/MED | 15° |
| 4 | UNAUTHORIZED | UP/DET | 11°/MED | |

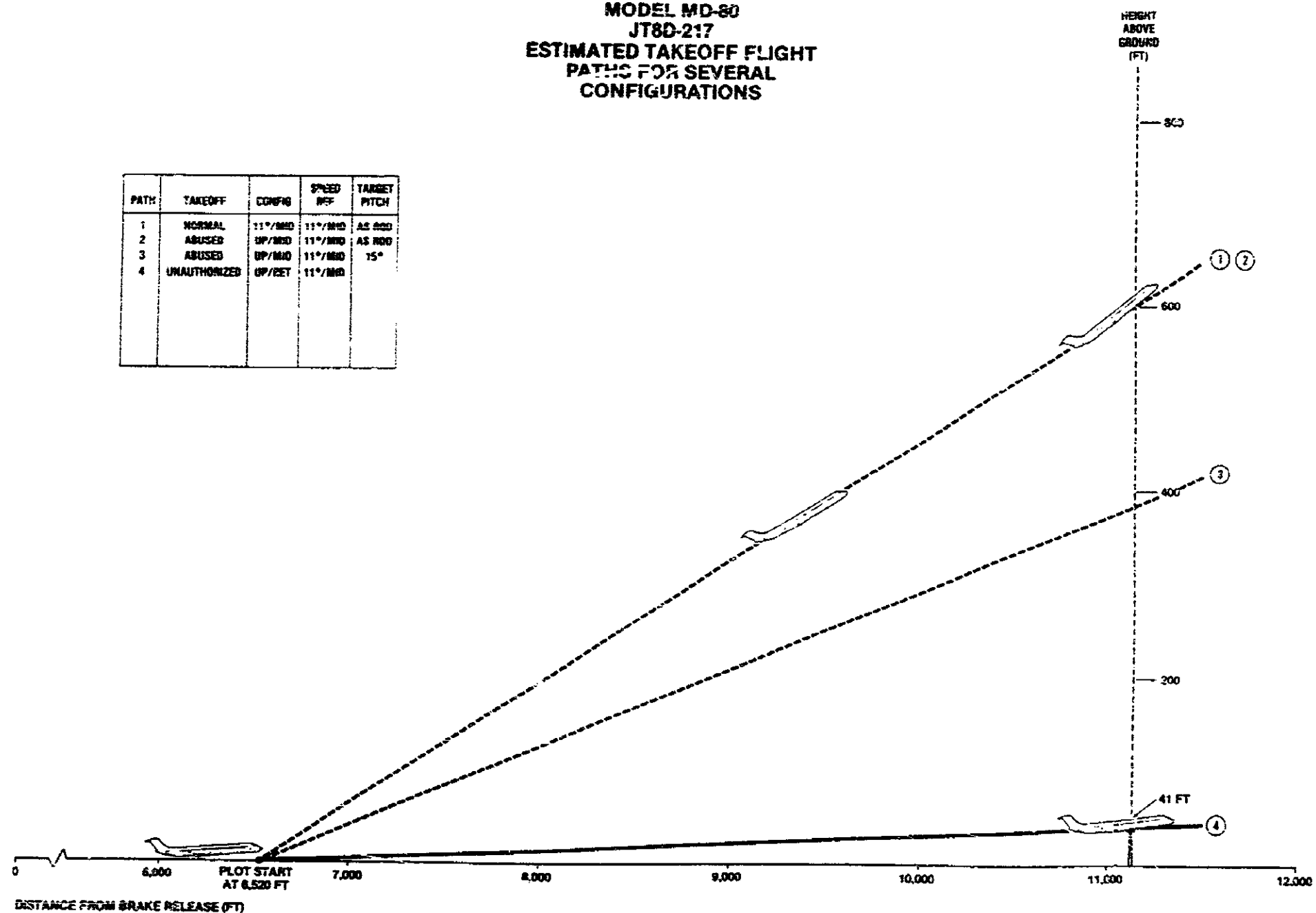

Figure 2.--Model MD-80, JT8D-17.
Estimated takeoff flightpaths for several configurations.

Two simulations were performed: the first reproduced the performance of the command bars during the actual takeoff wherein the go-around mode was selected about 8 seconds before impact. The second reproduced the command bar performance without the selection of the go-around mode.

The first simulation showed that the command bar moved upward during the takeoff roll. Forty seconds after the takeoff roll began (T.O. + 40 sec.) and about 8 seconds before the airplane reached V_r , the fixed airplane symbol and the command bars were positioned about 2° nose-down and 5° nose-up, respectively, on the ADI's pitch ladder. At T.O. + 54 sec., during rotation, at main landing gear liftoff, the fixed airplane symbol and the command bar were positioned about 9° and 11° nose-up, respectively, on the pitch ladder. About 4 seconds after main gear liftoff when the first SRSS alarm activated, the simulation showed that the captain had essentially satisfied the command bar cues and no further pitch attitude change was being requested.

At T.O. + 60 sec., the F/D entered the go-around mode and the command bar immediately began to move upward between the third and fourth SSRS alarm. About 1 second after the go-around mode was annunciated, the CVR recorded the remark, "(right up to the vee bar.)" At that time, (T.O. + 61 sec.) the command bar was passing through about a 1° nose-up pitch command en route to its final command presentation, the stick shaker was activated, and a SSRS alarm was either in progress or had just ceased. At T.O. + 65 sec., the fixed airplane symbol and the command bar were about 13° and 15° , respectively, on the pitch ladder (see figure 3), and they maintained that presentation until impact.

The second simulation showed that, had the go-around mode not been selected, the command bar would have moved downward. About 5 seconds after go-around was annunciated (T.O. + 65 sec.), the fixed airplane symbol and the command bar were positioned about 13° and 12° nose-up, respectively, on the pitch ladder (see figure 4). At T.O. + 68 sec., about 1 second before impact, the fixed airplane symbol and command bar were positioned about 14.5° and 12° nose-up, respectively, on the pitch ladder.

Also the Safety Board investigated the possibility that the airplane might have encountered a windshear during the takeoff. The computed ground speed of the airplane during the takeoff roll was integrated with an indicated airspeed plot derived from the DFDR-indicated airspeed data. The two plots were virtually identical throughout their entire length. Had a windshear occurred, the ground speed and airspeed plots would have diverged from each other.

1.17 Other Information

1.17.1 Northwest Airlines and Republic Airlines Merger

On July 31, 1986, Northwest's acquisition of Republic Airlines was approved by the Department of Transportation. On August 12, 1986, Northwest Orient Airlines completed its purchase of Republic Airlines. The new corporate name became Northwest Airlines, Inc., and new operations specifications were issued on that date. Although the former Republic and Northwest personnel and equipment operate under the name of Northwest Airlines, each operates as a separate entity, or company, and a separate set of operations specifications was issued to each company under certificate No. 301-F. The former and current certificate holding office for the carrier is Air Carrier District Office (ACDO) No. 34, Minneapolis, Minnesota.

The FAA has allowed each company to use its respective operations specifications, maintenance programs, and operations programs that were in effect on August 12, 1986, for a period of 18 months. Neither carrier is permitted to use a combined program without an approved provision to its operations specifications.

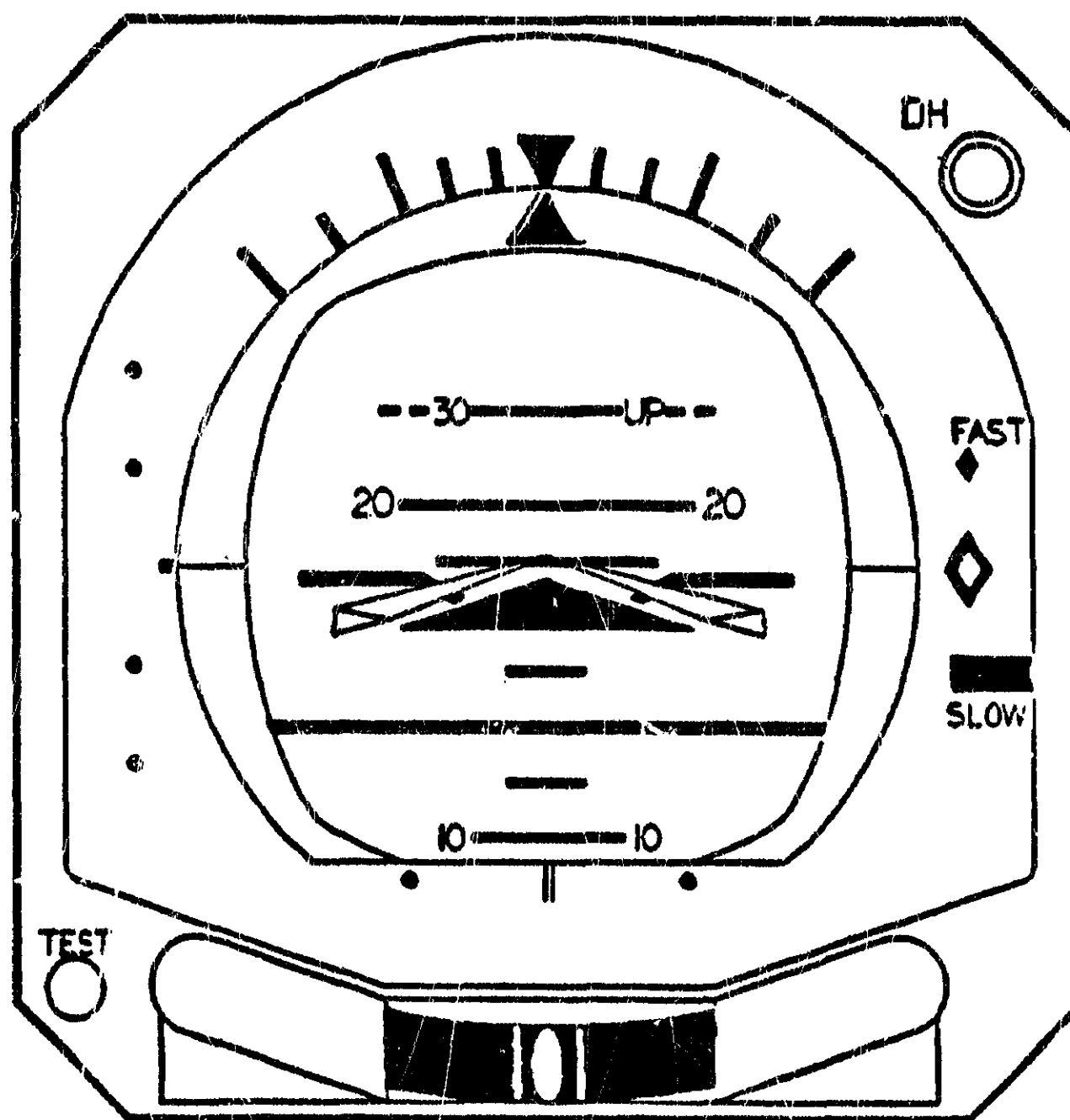

Figure 3.--Displays theoretical pitch attitude information presented by the ADI and the F/D command bar for the conditions existing 65 seconds after the start of the takeoff roll and after the F/D has entered the go-around mode. Roll attitude information and command bar roll guidance information is not displayed.

On October 1, 1986, plans to merge the two company's operations were issued with the integration of a consolidated flight schedule. The companies consolidated their route structure but continued to segregate their respective airplanes and flightcrews. However, the maintenance and flight attendant programs were integrated and the combined procedures were approved by the FAA. Flight attendants are now qualified to serve on all Northwest airplanes; this is the only change arising out of the merger thus far to the flightcrew checklists. Communications procedures between the flight and cabin crews on all airplanes were changed to coincide with those in use on former Northwest airplanes. However, the pilot groups continue to operate their respective airplanes in accordance with their respective operations specifications and their respective labor contracts.

Before the merger, the Northwest fleet consisted of Boeing airplanes and McDonnell Douglas DC-10s. During the merger, Northwest acquired a fleet of 134 DC-9s, 3 B-727s, and 6 B-757s

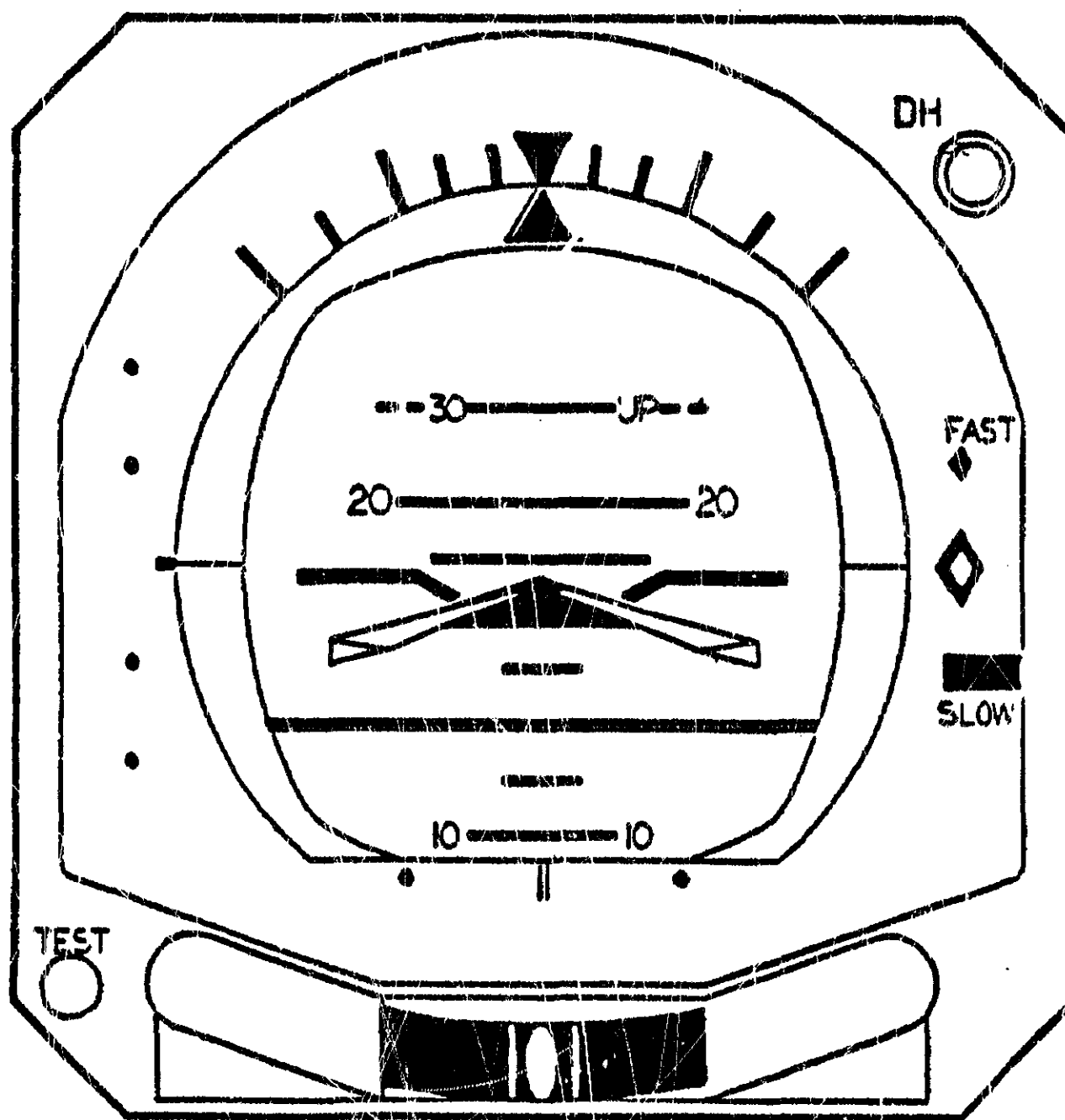

Figure 4.--Displays theoretical pitch attitude information presented by the ADI and the F/D command 65 seconds after the start of the takeoff roll with the F/D in Takeoff mode. Roll attitude information and command bar roll guidance is not displayed.

with 3 more on order. After the merger, the new corporation sold the B-727s and the B-757s and canceled the orders for the new B-757s.

1.17.2 Proficiency Training

Since the premerger Northwest Orient Airlines did not operate DC-9 type airplanes, the former Republic DC-9 training staff, except for some procedural changes in chain-of-command structure and reporting, remained virtually intact throughout the changeover. Thus, the DC-9-82 proficiency training program remained unchanged, and the evidence showed that the curricula complied with the regulatory requirements.

The DC-9-82 simulator proficiency training curriculum required students to demonstrate their proficiency in stall recovery procedures and coping with various windshear

models. The recommended procedures for accomplishing recoveries from these situations are contained in the Flight Maneuvers section of the company's APH. With regard to stall recovery, the APH states, in part, that the approach to stall "is reached at the first indication of the stall warning, stick shaker, or buffet, whichever occurs first." The recommended recovery procedures state:

- a. Apply and call "MAX POWER FLAPS 15" while simultaneously relaxing the back pressure enough to stop stick shaker or buffeting . . . The pilot not flying will select 15° flaps and trim the throttles to MAX POWER. Do not allow a pitch up to occur with the power and configuration changes, to avoid including a secondary stall.

With regard to windshear recovery, the APH states, in part:

- a. Advance the throttles to the mechanical stops.
- b. Smoothly rotate to a pitch attitude that will prevent ground contact. Although a stick shaker can be anticipated during this maneuver, do not rotate beyond the point that the stick shaker is activated.

NOTE

The airspeed may indicate considerably below V₂ or VREF bug (a computed landing approach speed based on the airplane's landing weight.)

- c. When descent has been arrested, position the flaps to go-around (if required) and be prepared to increase the body angle to prevent descent.
- d. When a climb is noted on the altimeter call "GEAR UP" (if required). . .
- e. After the recovery is completed, use standard climb procedures.

With regard to item c above, the rejected landing procedures contained in the APH state that the flap setting is 15°; however, it should be noted that this procedure is normally begun with landing flaps (28° or 40°) set on the airplane.

On May 31, 1987, the captain completed his DC-9-82 requalification simulator rides. Since there was no line first officer available, the Northwest DC-9-82 training manager, who was administering the requalification check, served as first officer. Examination of the applicable training documents showed that the captain demonstrated proficiency on stall recoveries in both the landing and takeoff configurations on two simulator flights and "stall recoveries using windshear recovery procedures" on the second flight; however, he did not receive stall recovery training with the airplane in the flaps up, slats retracted configuration. The training manager commented on the training form "Very nice requalification."

The first officer training records showed that he demonstrated his proficiency in recovering from stalls with airplane in the takeoff and landing configuration; however, he did receive stall recovery training with the airplane's slats and flaps retracted. The records showed that during his recurrent training, he had received windshear training. The training records also indicated that his last proficiency check was a one pilot-session, i.e., the instructor occupied the captain's seat in the simulator.

The training manager also testified, "I would comfortably say that every pilot that flies the MD-80 has at some point in his training been alerted to the fact that we have got a central aural warning system fail light on the annunciator panel . . . and if there is a failure in that system we would expect to somehow be annunciated. Although I cannot say that we train to that because there is not a requirement to train to that."

1.17.3 The DC-9-82 Checklist

Copies of the DC-9-82 checklist are kept on board each airplane. (See appendix E.) To view the checklist, pilots fold it along the dashed line and expose the applicable portions of the list as they perform the required tasks. The checklist normally is mounted to a clip on top of the pilot's control column and, thus, is displayed to the pilot between the horns of the control wheel.

Before May 21, 1985, the flaps were extended to 15° after the airplane began taxiing. Douglas had recommended that the flaps be extended to 15° to minimize engine exposure to foreign object damage (FOD), and the company had adopted that procedure for taxi out. However, the DC-9-82 generally uses takeoff flap settings of either 7° or 11° which required the flightcrew to reposition the flaps to the takeoff setting before taking the runway. Consequently, the BEFORE TAKEOFF checklist contained the item "FLAPS" at which time the flightcrew would reposition them from 15° to the required takeoff position. Subsequently, Douglas informed operators that the concern over FOD, as well as the effectiveness of the flaps to protect the engines, was not as great as originally believed. Therefore, Republic's Flight Standards Department decided to have its flightcrews set the flaps to the takeoff setting instead of 15° when the airplane began taxiing. Republic believed that would be more efficient since it would require only one movement of the flap handle and would lessen the crew's duties during the before takeoff environment. On May 21, 1985, "FLAPS" was added to the TAXI CHECKLIST, and crewmembers were directed to check and verify that the flaps and slats were positioned to the required takeoff setting in response to the challenge "FLAPS." The item "FLAPS," requiring the same challenge and response verification, was not deleted from the BEFORE TAKEOFF CHECKLIST. Having "FLAPS" on both checklists was intended to be temporary for the purpose of providing an orderly transition of the item from one checklist to the other.

On December 15, 1986, after receiving FAA approval to implement the change, a checklist change removed "FLAPS" from the BEFORE TAKEOFF checklist.

1.17.4 Checklist Procedures

The Standard Operating Procedures section of the Northwest APH contains the company's procedures and policies concerning how the airplane's checklist is to be used. The APH states, in part:

Good cockpit management requires consistent checklist usage. Proper use of checklist is reliable, and fosters predictable and standardized crewmember interaction.

Checklists are developed to provide convenient and natural flow patterns in the cockpit and are sequenced to meet operational requirements. Checklist items may be performed without direct reference to the checklist, however, all checklist items will subsequently be read aloud in sequence while visually checking the items to assure completion. Upon completion of an individual checklist, the pilot completing the checklist will state "(CHECKLIST NAME) CHECKLIST COMPLETE."

During all ground operations it is the Captain's responsibility to call for all appropriate checklists. . . Giving consideration to other required crewmember duties and allowing for adequate time for completion. The First Officer will query the Captain if there is abnormal delay in the call for any checklist.

The checklist items will be read in a loud clear voice and the proper response will be equally clear and understandable. Where a challenge and response item is performed, a response is required from another crewmember, the crewmember reading the checklist will repeat the challenge if necessary until the proper response is provided. Undue haste in the execution of any checklist is neither necessary nor desirable.

The normal checklist uses asterisks to delineate the division of duties between the captain and first officer. (See appendix E.) The duties are defined as follows:

No asterisks - The captain will perform the checklist item and provide the proper response.

* - The first officer will perform the checklist item and state both the challenge and proper response.

** - Both pilots will perform the checklist item and both will state the proper response.

(AS REQ) The crewmember responsible for completing the checklist item will check, or reposition, the referenced switch or control and then STATE THE POSITION OF THE SWITCH OR CONTROL.

Section 2-23 of the APH amplifies the procedures contained on the TAXI checklist. The APH states that the first officer may, once clear of the ramp area, perform some of the checklist items, (i.e., extend the flaps, set the trim or EPR bugs, etc.) in preparation for the captain calling for the TAXI checklist. Thereafter, with regard to the first item on the checklist, the APH states, in part:

FLAPS.....(SETTING)**

The checklist challenge "FLAPS" requires a standard response from both pilots. The APH states, in part, that the first officer will issue the challenge after leaving the ramp and then check the position of the flap handle. If the flap handle is not set to the takeoff flap setting, he will extend the flaps to the takeoff setting and accomplish the following: check that the flap handle is in the desired position; check that the flap indicator reading corresponds with the handle's position; and check that the slat takeoff light is on. After the above checks have been accomplished and the flap and slat settings verified, he will call out the flap setting, i.e., "FLAPS 11." The captain will then check that the flap indicator agrees with the first officer's call out and respond with the observed setting, i.e., "FLAPS 11."

The CVR recording showed that the required flap setting call outs were not made. The recording also showed that the captain did not call for the TAXI checklist and that the first officer did not ask him if he wanted to perform the checklist. During this period, the CVR recording contained references to only two items on the TAXI checklist. At 2036:37, an unidentified voice in the cockpit said, "Vee (V) speeds -- okay"; there was no response to the remark. At 2036:40, the captain said, "Trim setting;" there was no response to the remark.

The APH's TAXI Checklist Amplification section described flightcrew duties required by the item EPR & AIRSPEED BUGS. The section contained guidance relating to the airplane's TCI. Since reduced thrust could not be used for takeoff, only the guidance relating to normal takeoff thrust procedures are discussed herein. Based on this section of the APH, this checklist item required the flightcrew to either program or verify that the TCI was programmed properly for a normal thrust takeoff: "00" should have been inserted in the TCI's assumed temperature window and the "T.O." button pressed to obtain the takeoff EPR limit setting.

The next item on the TAXI checklist required the ART switch to be positioned "(As Required)." The amplified checklist procedures stated, in part, that the ART switch should be "ON" in the "Auto" position with the guard closed when "T.O" mode has been selected on the TCI. When the "T.O./Flex" mode is selected, the "ARTs switch must be off." On this takeoff, since the "TO" mode should have been selected, the flightcrew should have verified that the ART switch was either in "Auto" or placed in "Auto." If the slats were extended, the green ART ready light would have illuminated when the ART switch was placed in "Auto," and the autothrottle system would have been available when the autothrottle switch was activated.

With regard to the other applicable sections of the checklist, the CVR recording showed that the only checklist that was called for and pronounced complete almost in accordance with the APH procedures was the BEFORE (engine) START checklist. At 2029:10, the first officer called the first challenge item on the checklist, "Brakes." The captain did not respond to the challenge, but, at 2029:18, he said, "Lets do the checklist." At 2032:54, the first officer announced, "The before start checklist is complete." However, the recording also showed that, at 2032:46, the first officer read the last three challenges on the checklist, "Ignition, seat belt sign, beacon." The captain was required to accomplish these items and reply that all three of these switches were "On." However, at 2032:52, the first officer stated, "They're all on," and thereafter, that the checklist was complete. At 2032:57, the captain stated "On, on, on."

At 2034:08, the first officer stated "annunciator," to which the captain responded "checked," followed at 2034:09 by the first officer's verbal accomplishment of the remaining items on the AFTER START CHECKLIST. The CVR recording showed that the captain did not call for the AFTER START CHECKLIST, nor did the first officer ask the captain if he was ready to perform the checklist. The CVR recording also showed that the first officer did not state "after start checklist complete."

The BEFORE TAKEOFF checklist contains four items and this checklist was not accomplished in accordance with the standards contained in the APH. The captain did not call for the checklist nor did the first officer ask the captain if he was ready to perform it. The first item required the first officer to challenge "Flight Attendants" and then respond "Notified." Although, at 2042:36, the first officer had notified the flight attendants to be seated, he did not accomplish this checklist item properly. The remaining three items were accomplished properly, but the first officer did not tell the captain that the checklist was completed.

1.17.5 Human Performance Research Projects

During the Safety Board's public hearing, the Board sought and received testimony from psychologists concerning projects which either have evaluated or are evaluating the effects of automation on flightcrew performance and how interpersonal relations between flightcrew personnel affect their performance of cockpit duties.

A professor of management sciences and computer information (management sciences) at the University of Miami, Coral Gables, Florida, testified about the effects that the automated systems in the advanced modern airplanes cockpits appear to have had on flightcrew performance. With regard to the term "complacency," the professor testified that it was an "ill

defined" term; however, if forced to describe it he would state that it was a "relaxing of one's guard." He testified, "that the notion in automation is that if the equipment is reliable, and most of it is extremely reliable, this will generate complacency, a relaxing of one's guard."

The management sciences professor testified that the research projects had identified a phenomenon which the researchers called the "primary backup inversion where the primary system, which is the human and human vigilance, becomes the backup system, and the backup system, the machine, becomes the primary." He cited as an example the altitude alerting system which, during climb or descent, is programmed to provide an alert to the flightcrew 700 feet above or below the inserted level off altitude. Virtually all air carrier procedures require the nonflying pilot to provide a 1,000 (foot)-to-go alert call to the pilot flying the airplane when climbing or descending. He testified that "it doesn't work that way. So what do you see on climbing or descending? The pilot will sit there . . . until the altitude reminder sounds (and then) say 'a thousand to go.' That's the primary backup inversion. He has used a backup system to human vigilance and made it the primary system and then he reacts."

The management sciences professor described what he thought of as six lines of defense against an untoward consequence resulting from human error. The first line of defense was human vigilance; the second, another crewmember detecting error; the third, secondary indications, such as cockpit displays and instrumentation; the fourth, warning and alerting devices; the fifth, persons other than crewmembers detecting the error, i.e., ATC personnel or ground personnel; and the sixth, machines that take action on their own to rectify the error, i.e., the DC-9-82's autoslat and stick pusher systems. With regard to the first line of defense, the professor testified that it was, "of course, normal procedures, and that is the crew doing the right thing, supported by checklist, training, experience, manuals, discipline, check airmen, and what not."

With regard to checklist presentations, the management sciences professor testified that he did not know of any human factors research on how a checklist should be designed and that he could not find anything in his library on the subject. "There are a couple of human engineering handbooks and under 'checklist' about all they said was the type ought to be visible and it ought to be easy to handle . . ."

A National Aeronautics and Space Administration (NASA) research psychologist testified about the observations made by a group investigating the effects of interpersonal relationships on the performance of cockpit duties. He testified that, beginning in the late seventies, NASA began placing volunteer flightcrews from several airlines in "a high fidelity flight simulator and trying to replicate every aspect of [their] real world [flight environment] in a very highly controlled setting in order to determine some of the factors that did effect successful crew performance." The NASA psychologist testified that the project was not completed, that the research is still in progress, and that the research group had neither arrived at nor released any conclusions. The NASA psychologist's observations cited herein are limited to those areas which the Safety Board considered germane to this report.

The NASA psychologist discussed the effect of role structure in the cockpit environment. He testified that the term "role structure" refers basically to the degree and specificity of the structure of a groups activities. "With cockpit crews you would have a very well defined role structure, each position being well defined and having specific responsibilities in the cockpit." He testified that role structure performs a very valuable function and that, "the safety of the system, I think, in many ways is a testament to how well defined and how functional the roles are in the cockpit. But one of the other characteristics of a well defined role structure is it significantly reduces ambiguity about who is going to do what and at what particular time."

The NASA psychologist testified that the simulation studies have disclosed crews whose performances could be classified as "effective" or "less effective," that a number of

differences which they have seen "between the so-called effective crews and the so-called less effective crews are very reliable and appear time and time again." He testified that with regard to the highly effective crews, "there is much more communication in general . . . but there are also differences in the type of communication . . . You see much more task oriented communication." He testified that one of the patterns we tend to see, "is what we call the information acknowledgment sequence . . . We find that (with) crews that are highly effective . . . we tend to see many more acknowledgments to anything that is said."

The NASA psychologist testified that the manner in which the subject flightcrews used their checklists also was evaluated. He testified that it was rare to see a checklist ignored completely or not done but that this had occurred from time to time during various phases of flight in the simulator. There was a lot of variation with regard to checklist usage and it varied from the conduct described above to a "very clearly read challenge/response methodology."

The NASA psychologist testified that evidence suggested that the way the checklists were used were directly related to the number of errors made by the flightcrews. The flightcrews that performed their checklist duties "by the book, challenge (and) response methodology . . . tend to perform more effectively." He testified that he was not familiar with any body of research relating to the construction and presentation of checklists, but it was his opinion that, "there are probably many ways to do a checklist correctly. What's important is that everyone agrees on how it should be done, and then it's done the same way every time by all the people that are concerned."

An article in the Boeing Airliner Magazine ^{10/} concerning flightcrew-caused accidents and citing the Boeing fleet over a 10-year period as an example stated that:

16 percent of the operators have crew-caused accident rates higher than the fleet average, and these operators account for over 80 percent of the total accidents.

Conversely, 80 percent of the operators had no crew-caused accidents over the same period . . .

The authors of the article contacted a small group of operators, "most of which had better than average crew-caused accident history" with a view to obtaining information on the policies and techniques that contributed to their safe operations. They found that:

Management recognizes the need for aircrews performing in a standardized way and the importance of cockpit discipline in providing the environment for proper crew coordination.

With regard to check airman, the article notes that a strong check airman program acts as a continuous quality control check on the training department and that methods exist for assuring the uniformity of check pilot techniques and instruction.

In the area of cockpit discipline and procedures some of the procedures used by these operators were as follows:

^{10/} L.G. Lautman and P.L. Gallimore, "Control of the Crew-Caused Accident" Airliner Magazine, Boeing Commercial Airplane Company, April-June 1987.

There is a firm requirement for in-depth takeoff and approach briefings for each flight segment . . . One operator requires an RTO [rejected takeoff] touch drill in which each control used during the RTO is sequentially touched by the pilot making the takeoff.

Cockpit procedural language is tightly controlled to maintain consistency and to avoid confusion from non-standard callouts, which can result from crewmembers using differing phraseology. Callouts and responses are done verbatim. The recurrent training program and check pilot system rigidly enforce this requirement.

1.17.6 FAA Surveillance

FAA ACDO No. 34 held the respective certificates and was responsible for surveillance and oversight of the former Northwest and Republic Airlines.

The principal operations inspector (POI) assigned to the current Northwest operation was also the pre-merger Northwest POI, a duty which he assumed in January 1985. He is assigned only to Northwest and is responsible for the oversight of the operational procedures and training relevant to the carrier's total fleet.

During February 1986, the FAA assigned an aircrew program manager (APM) to the Northwest DC-9 fleet to assist the POI. The APM is rated in the DC-9, -10, -30, -50, and -82 airplanes. The APM works for the POI and serves as his technical expert on the DC-9 fleet and on how Northwest operates it. He has no additional oversight for any other airplanes in the Northwest fleet nor for any other carrier.

The APM duties include monitoring proficiency checks, training programs, designated flight examiners, manual changes, procedures, and surveillance. Currently, five examiners assist him. Between October 1986 and August 1987, the FAA conducted 1,493 operations inspections, 819 maintenance inspections, and 293 avionics inspections on the Northwest DC-9. The APM surveillance activities are further assisted by 174 FAA-approved DC-9 check airmen who are qualified to conduct line checks and proficiency checks in the DC-9 airplanes and simulators.

1.18 Useful or Effective Investigative Techniques

Recorded LLWSAS Wind Sensor Data

On March 25, 1983, the Safety Board recommended that the FAA record output data from all installed LLWAS sensors "and retain such data for an appropriate period for use in reconstructing pertinent windshear events as a basis for studies to effect systems improvements." ^{11/} The FAA agreed with the recommendations and began installing recording capability on selected LLWAS. Detroit-Metro's LLWAS recording equipment was commissioned on November 3, 1986, and the equipment was operating at the time of the accident.

Since using the Detroit LLWAS to reproduce the recorded wind data would have required removing the entire system from operation for 2 hours, the recordings were taken to the Program Engineering and Maintenance Service facility at the FAA's Aeronautical Center, Oklahoma City, Oklahoma, where the data were reproduced and read out, and the wind directions and speeds recorded by the system's sensors were obtained. The recorded LLWAS data were instrumental in allowing the Safety Board to determine the wind conditions which existed at Detroit-Metro Airport at the time of the accident.

2. ANALYSIS

2.1 General

The captain and the first officer were qualified in accordance with applicable Federal aviation regulations, company regulations, and procedures to operate the airplane.

The airplane's maintenance records disclosed that it had been maintained and operated in accordance with applicable Federal aviation regulations and company operations specifications, rules, and procedures. Except for the possible failure of the takeoff warning system to provide an aural warning for an improper takeoff configuration, there was no evidence of any preexisting malfunctions or failures of any airplane structures or systems which would have been a causal factor to the accident. The analysis of the performance of the takeoff warning system will be discussed in greater detail herein.

The changeover of Detroit-Metro's runway operation from a runway 21 to a runway 3 configuration was accomplished in accordance with published ATC procedures. The decision to change the direction of traffic was based on the tower supervisor's judgment that the wind direction was changing from southwest to northwest. The LLWAS's recorded data confirmed the supervisor's description of the wind shift. At 2029:31, about 1 minute 31 seconds after the runway change, the LLWAS centerfield wind was 290° M at 20 to 21 knots. On runway 3C, this wind would have produced crosswind and tailwind components of about 19 and 5 knots, respectively. The direction of the wind continued to shift toward the northwest. About 2045, based on NWS records and LLWAS data, the most likely range of winds would have been from 305° M at 12 to 16 knots. On runway 3C, these winds would have produced crosswind components between 11.8 and 16 knots and headwind components between 0 and 2.8 knots. Since runway 27 was closed, the wind shift was producing winds which favored slightly the runway 3 configuration. Based on these data, the Safety Board concludes that the supervisor's decision was reasonable.

^{11/} Safety Recommendation A-83-15

The light pole struck by flight 255 was 2.2 feet higher than the 40-foot height that was approved in the FAA's aeronautical study. However, the 42.2-foot-high pole did not penetrate any civil airport imaginary surface, and the impact point on the pole was 37 feet agl. Therefore, the Safety Board concludes that the pole's additional height was not a causal factor.

When the left wing struck the light pole the wing's fuel tanks were ruptured and released fuel. The fire observed by some witnesses during this part of the accident sequence was caused when the left engine torched after it ingested the fuel. The carbon deposits inside the engine's front accessory case further corroborate this occurrence.

Given the fact that the deaths of the passengers and crew on flight 255 were the result of multiple blunt force trauma, the fact that the airplane disintegrated during the impact sequence, and the fact that the crash forces destroyed the livable volume of the cabin, it was obvious that these forces exceeded the limits of human tolerance to abrupt acceleration. Therefore, the Safety Board concludes that this was a nonsurvivable accident. The survival of the 4-year-old female child can only be attributed to a combination of fortuitous circumstances.

The CVR transcript showed that the first officer made the required callouts during the takeoff roll. Therefore, the Safety Board concludes that the captain was flying the airplane at the time of the accident.

2.2 The Accident

The evidence showed that windshear alerts had occurred at Detroit-Metro and that windshears had been reported near the airport by pilots during the 30 minutes before the accident. In addition, the evidence showed that flight 255's stall warning stick shaker had activated immediately after liftoff and that, thereafter, the flight failed to either match or approach its predicted climb profile. This evidence suggested initially that the airplane encountered a windshear that decreased significantly its performance capability. A loss of an airplane's climb performance can be caused by a strong downdraft or a rapidly decreasing head windshear. Therefore, the Safety Board first sought to determine whether flight 255 had encountered such a shear.

The performance loss of an airplane that encounters a significant windshear during takeoff is discernible from the parameters recorded on the airplane's DFDR. As the airplane enters the shear, a change in the airspeed vector as measured by indicated airspeed and the angle of attack occurs without corresponding changes to the measured inertial acceleration parameters. Stall warning devices will activate at the expected angle of attack for the airplane's configuration.

However, examination of the CVR and DFDR data readouts showed immediately that the airplane had not encountered a decreasing headwind type of windshear. The DFDR data showed that, at liftoff, the airplane's airspeed was about 169 KIAS and that instead of decelerating over the last 14 seconds of the flight, the airplane accelerated to about 184 KIAS and climbed about 48 feet. This performance was not consistent with the expected performance of an airplane that is caught in a decreasing head windshear. The fact that the airplane did not encounter a windshear was further corroborated by the lack of divergence between the airplane's ground speed and indicated airspeed during the time it was airborne.

The correlated CVR and DFDR readouts showed that during the 14-second flight, the airplane's stick shaker remained activated continuously, and its SSRS activated four times. With the flaps at 11° and the slats in the mid-sealed position, the airplane's stall speed was about 121 KIAS; if the flaps were retracted and the slats remained in the mid-sealed position, the stall speed would increase to 128 KIAS. Despite the fact that the 169 to 184 KIAS recorded during the flight exceeded the worst of the two stall speeds by 35 to 56 KIAS, the stall warnings persisted. The investigation

indicated that the only wing configuration that would continue to activate the stall warnings between 169 and 184 KIAS was a wing that was in cruise configuration, i.e., slats and flaps retracted. Consequently, the Safety Board concluded that the airplane had not encountered a windshear and directed its investigation to determine the configuration of the airplane during the takeoff roll. The following areas of evidence were available to the Safety Board for this analysis: the DFDR readouts and, where applicable, the CVR recording; the airplane performance study; and the physical evidence at the impact site.

2.3 The DFDR Readout and Airplane Performance Study

Examination of the recovered flap sensors, the DFGC memories, and the fact that those airplane systems whose performances would have been adversely affected by a malfunctioning slat position sensor(s) performed within prescribed parameters showed that the information received by the DFDR accurately reflected the positions of the wing flaps and slats.

The DFDR readout of the accident flight covered the entire period between pushback from the gate and impact, except for two intervals where the data stream was interrupted because the airplane's parking brakes were set. The first interruption occurred after the airplane was pushed back from the gate. At 2034:25, the captain told maintenance personnel "Brakes are set," and the power to the DFDR ceased. At 2034:57, after the tow bar was removed, the flight acknowledged its taxi clearance, and, at 2035:03, power was restored to the DFDR. The second interruption began at 2043:18 after the flight had taken the runway, turned to the runway heading, and was holding in position awaiting takeoff clearance. At 2044:04, the local controller cleared flight 255 for takeoff, and, at 2044:14.8, the CVR transcript contained a "(sound similar to parking brake released.)" At 2044:20, power was restored to the DFDR. The DFDR readout showed that the recorded values for the flaps and slats were identical at the beginning and at the end of each of these two data stream interruptions. The recorded values showed that the flaps and slats were in the retracted position and that there was no disagreement between the slat position and the flap handle position. In addition, the DFDR readout showed that, from pushback to impact, during the entire period that power was on the DFDR, the flaps were always retracted, the slats were always retracted, and there was no disagreement between the positions of the flap handle and slats.

The only position of the flap handle that will place and keep the slats in the retracted position is the UP/RET detent. Moving the flap handle to any other select position on the flap handle track will move the slats out of the retract position to either the mid-sealed or the extended position as the case may be. Had the flap handle been moved from the UP/RET detent to another detent, the DFDR readout would have shown the slats in transit and a disagreement between the flap handle and slat positions until the slats had reached their new commanded position. Throughout the entire readout, the recorded data showed that the slats never moved from the retracted position and that the flap handle position never disagreed with the slat position. Therefore, the Safety Board concludes that the DFDR data showed that the flap handle was never moved out of the UP/RET detent.

The Safety Board's airplane performance study also showed that flight 255 was not configured properly for takeoff. The recorded DFDR data showed that both engines were operating at or above takeoff power and, that although the acceleration up to and through V_r was in accordance with predicted rates, the airplane did not lift off at the predicted pitch attitude. Assuming proper takeoff configuration, the airplane should have lifted off between a 6° and 8° noseup pitch attitude. In this instance, the airplane rotated to an 11° noseup attitude, stabilized at that attitude, and accelerated to a higher airspeed before liftoff. The liftoff speed provided further evidence that the airplane was not configured properly. With both engines operating at takeoff power, a properly configured airplane typically should have been at $V_2 + 10$ KIAS (163 KIAS) by the

time it climbed through 35 feet agl. However, the accident airplane did not lift off until it accelerated to about 169 KIAS.

The Safety Board's performance study examined the climb profiles depicting the DC-9-82's ability to clear the obstacles beyond the end of runway 3C. The profiles showed that only the flaps and slats retracted takeoff configuration placed the airplane within dangerous proximity of the first light pole. The profiles also showed that with either slats in the mid-sealed position and flaps 11°, or with the flaps retracted and the slats in the mid-sealed position, the airplane would have cleared the light pole by 400 to 600 feet.

The information contained in the performance study corroborated the DFDR data that the takeoff was made with the flaps and slats retracted.

2.4 The Physical Evidence

The Trailing Edge Flap System.--The measurements of the extensions of the flap system's hydraulic actuators were inconsistent because the hydraulic lines to the actuators were broken, and there was no pressure available to hold the actuators in place throughout the entire impact sequence. However, other physical evidence was examined to determine the flap position at the time the airplane struck the railroad embankment.

The wing's trailing edge flaps are supported and guided at their inboard ends by curved tracks that travel along rollers mounted to the fuselage. When the airplane struck the ground, both flaps broke from the airplane and damaged their tracks. The shapes of the damaged areas on the flanges of each track matched the shape of the fuselage-mounted rollers, and the distance between the damaged points was the same as the distance between the rollers. In addition, the locations of the damaged areas on the flanges corresponded to the position that the rollers would have been in the tracks when the flaps are fully retracted.

Before assessing the reliability of this evidence, the Safety Board considered the scenario that the flaps were extended to 11° and that the initial impacts with the light standard and the rental car facility damaged the hydraulic lines and allowed the air loads to retract the flaps before the airplane struck the ground and they were broken from the airplane. The airplane's initial impact with the light standard did not break any hydraulic lines, but, thereafter, when the airplane struck the rental car facility, it is likely that the hydraulic lines to the left outboard spoiler and the outboard actuator of the left outboard flap ruptured. Since the neutral position of the flap control valve would have isolated the flap actuators from the remainder of the hydraulic systems, the rupture of the spoiler lines would not have immediately affected the flaps. While the rupture of the lines to the aforementioned actuator would have resulted in the loss of left hydraulic system pressure to the flaps, the right hydraulic system remained intact and its pressure alone was sufficient to prevent flap retraction from airloads.

In addition, pressure from the right hydraulic system should have prevented any movement of the left flap followup cable. Movement of this cable could bias the flap control valve and initiate flap retraction. The airplane traversed the distance between the rental car facility and the initial impact site in 1.5 seconds. Based on the flaps' normal rate of movement, it would have taken 6 seconds for them to retract from 11° to full up; therefore, even if the left flap followup cable had moved, the flaps could not have retracted from 11° to the up position in 1.5 seconds. The Safety Board concludes that the damaged areas on the inboard flap tracks presented a reliable portrayal of the position of the flaps when they were torn from the airplane, and, considering the 1.5-second interval between the impacts with the building and railroad embankment, the Board also concludes that the flaps were up when the airplane hit the building.

The flap handle was in the UP/RET position when it was found in the wreckage. The disassembly of the flap handle module showed that its right side was displaced to the left, forcing the flap handle to the left and against the fixed detent track. The handle's fixed detent pin was intact in the UP/RET detent, and there was a circular impact mark in the side of the detent which matched the end of the fixed detent pin. The orientation of a raised metal lip around the end of the detent pin matched the circular impact mark in the UP/RET detent.

The flap takeoff selector (dial-a-flap) movable detent was stowed and the cam finger detent mechanisms were scratched. The scratch most probably was produced by the dial-a-flap detent pin as the flap handle was displaced downward during impact.

There was no damage to the fixed detent pin and fixed detent track that indicated the flap handle had been in another detent during takeoff and was forced to the UP/RET detent during the impact sequence. Had the flap handle been positioned in the 11° detent and then forced forward during impact, the detent pin would have sheared and the fixed detent track most probably would have been damaged significantly.

Physical evidence supports the conclusion that the flaps were in the retracted position during the breakup of the airplane and that the flap handle was positioned in the UP/RET detent before impact.

The Leading Edge Slat System. --Except for a portion of the No. 5 slat which had remained attached to the 18-foot section of left wing which separated on initial contact with the light pole, the slat surfaces were destroyed. The examination of some of the recovered components of the slat actuation system produced contradictory evidence as to their positions at impact. However, the Safety Board believes that significant and reliable physical evidence depicting the position of the slats at impact was contained within the separated 18-foot section of the left wing.

The 18-foot wing section contained the drive cables from the slat drive drum to the transition drum of the No. 5 slats. The cables, which were routed just aft of the wing's leading edge, had been broken. When the slats were placed in the extended position, the cable breaks were 15.5 inches apart and neither of the breaks then matched the plane of the wing's fracture. However, when the cable breaks were aligned with each other, they aligned with the plane of the wing's fracture and the slats were in the retracted position. The Safety Board believes this evidence was most significant in determining the position of the leading edge slat before the initial impact. Given the location of the cables within the wing and the speed at which the airplane was traveling, the impact with the pole would have damaged the wing and the cables almost simultaneously. Since this damage was inflicted by the first object to strike the airplane, it showed that the slats were retracted at that time. This conclusion is further supported by the position of the flap handle.

In summary, the most reliable physical evidence of flap and slat position was the damaged inboard flap roller tracks and the breaks in the drive cables to the No. 5 slat transition drum. These items showed that the flaps and slats were fully retracted when the damage occurred. The slat cable damage was caused by the very first object the airplane struck, thus, showing that the slats were retracted when the left wing struck the light pole. During normal operation, the flaps cannot extend without the slats extending first; therefore, it can be concluded that the flaps also were retracted before the airplane hit the light pole. The damage to the flap handle and the significant impact damage to the UP/RET detent and adjacent area also supports this conclusion. The lack of damage elsewhere in the flap handle module further corroborated that the handle was in UP/RET detent before impact, rather than being forced to that position by impact forces. The most reliable physical evidence showed that the flaps and slats were retracted and in agreement with the full forward position of the flap handle at the start of the impact sequence.

The Safety Board also considered the statements of two Northwest first officers that flight 255's flaps and slats were extended. Their recollections were based on observations of an event which occurred after sunset, during twilight, and about 15 minutes before the time of official darkness. The Safety Board concludes that the recorded DFDR data, the physical evidence, and the resultant aerodynamic performance of the airplane during the takeoff were the more reliable evidence of the airplane's configuration.

Since only the flightcrew could extend the airplane's flaps and slats after it was pushed back from the gate, the Safety Board also concludes that the flightcrew did not extend the flaps and slats and did not configure the airplane properly for takeoff. However, the CVR transcript showed that the takeoff warning system, which was designed to warn the flightcrew that the airplane was not configured properly for takeoff, failed to provide the proper warning to the crew. Consequently, the Safety Board sought to determine the reason for this failure before analyzing the operational aspects of the accident.

2.5 The Central Aural Warning System

Except for the left wing slat's position sensors and the oleo switch on the nose landing gear, the Safety Board was able to examine and perform functional tests on every recovered component which provided information and electrical power to the CAWS unit. The examinations and testing showed that, at the time of the accident, these components functioned as designed. Both throttle switches were mounted in their separate switch bank units and functioned normally during these tests. However, destruction of the wiring harnesses precluded positive verification of complete circuit continuity. The throttle switches in the DC-9-82 are wired in parallel so either or both throttles will activate the warning and no single circuit failure can affect the system adversely. Therefore, two separate circuits would have had to have been open to disable the system. Since the wires are routed in separate bundles to two different connectors, the Safety Board believes that this scenario is improbable.

The missing left oleo switch controls the left ground shift system which deactivates the takeoff warning system when the nose landing gear extends; thus, a malfunction of this switch could have disabled the takeoff warning system. However, the left ground shift system also provided air-ground logic to the DFDR, and the DFDR would have recorded continuously while the airplane was on the ground if the switch had malfunctioned. Since the DFDR, as designed, ceased recording when the parking brakes were engaged while the airplane was holding in the takeoff position, the Safety Board concludes that this switch also functioned properly.

A fail light is mounted on the front of the CAWS unit which will illuminate when the unit's self-monitor detects an internal failure. The fail light is operated by a latching-type relay and once lit, the relay latches and the light remains lit until the unit is removed, opened, and the relay reset. The CAWS unit was virtually undamaged when it was recovered. The latchable relay fault light on the front face of the unit was not latched indicating that the unit had not failed any portion of its internal self-monitoring test before the accident. The testimony of a Northwest first officer who rode in the jump seat from Detroit to Saginaw indicated that the takeoff warning system had functioned after the airplane landed at Saginaw.

The sound spectrum analysis testing conducted in the Safety Board's audio laboratory permitted the Board to identify the takeoff warning's failure mode. Of primary importance to this analysis was the fact that the two SSRS alarms are connected to different power supplies in the CAWS unit: SSRS-2, the first officer's alarm, was connected to CAWS power supply-3; and SSRS-1, the captain's alarm, was connected to CAWS power supply-2. The takeoff warning system also was connected to power supply-2.

When both SSRs operate, an echo effect will be heard. The sound spectrum analysis of the actual warning generated by the accident airplane's CAWS unit showed that there was no echo effects, that only one SSR had provided the alarm, and that, based on the frequency components of the word, SSR-2 provided the alarm recorded by the CVR. This conclusion was further corroborated by the facts that no significant damage was noted on the filaments of either of the captain's bulbs; however, stretching, typical of an impact while the bulb filament is hot, was found on both bulbs of the first officer's warning light.

The evidence showed that the stall alarm was generated from power supply-3 of the CAWS unit's, and that, based on the facts that the takeoff warning system and SSR-1 did not operate, power supply-2 of the unit was inoperative. Had the output from power supply-2 failed while the 28V d.c. input power from the airplane's electrical system was still available, the fail light on the CAWS unit would have illuminated, and, more importantly, its internal relay would have latched and remained latched until released by maintenance personnel; this relay was found not latched after the accident. Therefore, the Safety Board concludes that the loss of the takeoff warning system was caused by the lack of 28V d.c. input power from the airplane to power supply-2.

Power supply-2 of the CAWS unit receives power from the left 28V d.c. bus through the P-40 circuit breaker. Loss of the airplane's left 28V d.c. bus must be ruled out as the source of the loss of power to power supply-2 because its loss would have been readily apparent to the flightcrew. Numerous indicating lights and gauges would have been lost. The loss of the bus would have been annunciated on the cockpit's overhead annunciator panel, the master caution light would have illuminated, and the loss of the bus would have caused failures which would have affected information recorded by the DFDR. The fact that the DFDR did not record any information indicative of these types of failure further confirms that the left 28V d.c. bus was powered throughout the flight. Since the bus was powered and the wiring from the P-40 circuit breaker to the CAWS unit was intact, but power supply-2 of the CAWS unit was not functioning, the process of elimination leads to the only remaining component in the input circuit where a power interruption most logically could occur--the P-40 circuit breaker.

Because the P-40 circuit breaker was badly damaged during the accident, it was impossible for the Safety Board to determine positively its preimpact condition. There were three possible conditions that would have caused power to be interrupted at the P-40 circuit breaker: the circuit breaker was intentionally opened by either the flightcrew or maintenance personnel, the circuit breaker tripped because of a transient overload and the flightcrew did not detect the open circuit breaker, or the circuit breaker did not allow current to flow to the CAWS power supply and did not annunciate the condition by tripping.

The Safety Board considered the possibility that the system was disabled by operating the P-40 circuit breaker as a switch and opening it intentionally. This might occur if any of the warnings operated by power supply-2 were producing nuisance warnings that annoyed or distracted the flightcrew. The testimony of the Northwest first officer who rode in the cockpit jumpseat from Detroit to Saginaw indicated that power supply-2 was operational at Saginaw, when he heard the words "flaps, flaps" annunciate. Also, no nuisance warning was recorded by the CVR between the beginning of the recording at 2013:27 and its end at 2045:24.7. The DFDR recording showed that both engines were operating during the taxi from the gate at Saginaw and to the gate at Detroit-Metro. Therefore, not only was it unlikely that a nuisance takeoff warning would have been generated by a prolonged high engine power setting, but power settings of this magnitude were not recorded. However the SSR-1, landing gear, auto-pilot disconnect, cabin altitude, and speedbrake warnings also are generated by power supply-2. Thus, it was possible that the power supply could have been disabled by the flightcrew for a nuisance warning other than the takeoff warning. The Safety Board cannot rule out this possibility. In addition, there was no evidence that

any person who would have reason to open or close the circuit breaker had done so between the time the airplane landed at Saginaw and departed the gate at Detroit-Metro.

The second possibility considered was that the circuit breaker opened electrically due to an undetermined transient overload condition, and that the crew did not detect the tripped circuit breaker. In this case, there would be no warning that such a condition existed and the location of the circuit breaker is such that a tripped breaker might not be visually detected, especially in low ambient light conditions. Although flightcrew members normally check the circuit breaker panels on entering the cockpit, the sixth item on the BEFORE START checklist requires a circuit breaker inspection and both crewmembers are required to accomplish this step and are required to respond to the challenge.

The P-40 circuit breaker, as well as the other two circuit breakers on the input power circuits to the CAWS power supplies, are located directly behind the captain's seat and can best be inspected by the first officer. At 2029:28, the first officer said "Circuit breakers, are ah . . ." At 2029:30, the captain responded, "Checked," and, at 2029:31, the first officer said, "Auto-land is checked radio altimeters and flight director."

The CVR showed that the first officer, with regard to the circuit breakers, did not respond properly to the challenge and response aspects of the checklist and that his inspection of the upper and lower circuit breaker panels behind the captain was completed within 2 seconds. Given the time expended by the first officer, the thoroughness of his check of the circuit breaker panels had to have been limited. In addition, the P-40 circuit breaker might have opened after the check while the airplane was being taxied. Under those circumstances, it was very likely that its condition would have gone undetected.

The third possibility examined was that the P-40 circuit breaker, for undetermined reasons, did not allow current to flow even though the latch appeared mechanically closed to the flightcrew. Typically, this anomaly occurs when the breaker is cycled open and is subsequently closed, such as might occur if a crewmember closes a breaker that has tripped open. In this case, foreign objects may lodge between the breaker contacts preventing full closure, as was evidenced by the examination of two of the circuit breakers at TI. Another means by which current could be impeded is the formation of a dielectric film that could build up on the contact surfaces through airborne contaminants flowing into the vented circuit breaker case. When the contacts are closed, the contact make-point may rest on the surface of the film, preventing current flow. These films are typically tenuous in nature, and the behavior of the two circuit breakers that originally were open and then were metered after little or no disturbance suggests that the presence of such a film was responsible for the open circuit displayed by these devices.

The stationary contacts of the two circuit breakers mentioned above were similar in conductivity to those of the bus bar stationary contact of the P-40 circuit breaker from flight 255, i.e., these contacts exhibited random areas of intermittency about the outer periphery of the contacts when continuity was tested with 1.5 volts. The bus bar contact of the P-40 breaker had been exposed to the environment for several weeks after the accident; thus, the possibility existed that the silver sulfide layer resulted from this exposure. However, other contacts on the same bus, which were similarly exposed to the environment, did not exhibit the silver sulfide tarnish. In addition, the contacts from about 70 circuit breakers in the accident airplane were examined and silver sulfide tarnish was found on contacts that were not exposed to the environment. Silver sulfide tarnish also was present on the stationary contacts of the two breakers that were analyzed at Klixon and were suspected of not conducting current due to the presence of a dielectric film. The silver sulfide tarnish buildup on the P-40 contact from flight 255 appeared among the heaviest encountered during the examination. Therefore, the Safety Board concludes that much, if not all, of the silver sulfide tarnish existed on the contact before the accident. The evidence makes it impossible for the Safety Board to

rule out that the current flow through the P-40 circuit breaker was inhibited by the presence of a dielectric film on the bus bar contact.

Personnel at Klixon stated that they are unaware of an instance where a closed and conducting circuit breaker suddenly stopped conducting and did not annunciate the condition to the flightcrew by tripping. The Safety Board agrees that this possibility seems remote given the design of the circuit breaker. Further, there is no information currently available regarding the in-service reliability of the devices, since service difficulties encountered regarding circuit breakers are seldom reported. However, testimony at the public hearing by nearly every pilot witness disclosed that periodically throughout their careers, they had regained the use of a system or component by opening and resetting the applicable circuit breaker. Possible failure modes for this scenario remain unidentified since the anomaly disappears once the circuit breaker is reset. Naturally, the type of system involved has some bearing on this behavior, and it may be in some cases that the circuit breaker is not responsible for the loss of the system. Nonetheless, the existing evidence suggests that circuit breakers may occasionally disable functioning systems for reasons that are not clear. Since this type of failure may not be readily apparent to flightcrews and may occur in critical systems, the Safety Board believes that the FAA should conduct a directed safety investigation to determine the reliability of circuit breakers and the mechanisms by which failures internal to the circuit breaker can disable operating systems, and to identify corrective actions as necessary.

The evidence did not permit the Safety Board to determine which of the three possible reasons interrupted the flow of current and caused the failure of the P-40 circuit breaker to power supply-2 of the CAWS unit.

The Safety Board supports the change to the MD-80 checklist contained in the Douglas telex as well as the efforts of the FAA to include flightcrew procedures in airplane checklists that will allow crewmembers to validate the operational capability of takeoff warning systems. Until such time as warning systems can, through the operation of internal self-testing equipment, furnish notice to a flightcrew that they are inoperative, these checklist procedures will enhance the flightcrew's ability to detect and deal with a failed takeoff warning system.

The evidence developed by the Safety Board during its investigation of the loss of power to the P-40 circuit breaker illuminated another area of concern. The evidence showed that the CAWS fail light was installed on the DC-9-82 to facilitate maintenance. The manufacturer believed that an increased level of dispatch reliability could be achieved if the flightcrew were made aware of in-flight CAWS anomalies and could notify maintenance personnel before landing. Maintenance could then meet the airplane with a replacement CAWS unit and facilitate airplane turn-around procedures. It was for this reason that the self-monitoring capability was built into the unit.

The CAWS unit's self-monitoring capability was also the reason that the CAWS fail light was not designed to annunciate the loss of 28V d.c. input power. Trouble-shooting can be limited to replacement of the CAWS unit if the only discrepancy that will illuminate the light is internal to the unit. However, from a safety viewpoint, this feature could be improved by modifying the design so that the CAWS fail light will illuminate not only with an internal failure, but with the loss of input power to the unit. This modification would change the behavior of the system so that it would perform in the manner reflected by the original FMEA that was approved by the FAA during the original certification of the airplane and system. The Safety Board believes that this type of warning is important to the concept of centralized aural warning since the loss of one power supply results in a number of disabled warnings, some of which may not be immediately recognizable to the crew.

As the number of required warnings is likely to increase in the future due to increasing complexity and automation, and the concept of centralized aural warnings is likely to be employed to a greater degree, a standardized approach to the design and certification of these systems should

be developed. This should also include a standardized approach to the determination of the type of warning to be provided and the criticality of these warnings, such that similar systems in different jet transport category airplanes are afforded the same degree of self-monitoring and failure annunciations. Currently, there is no structured method by which to approach these evaluations, with the final outcome often determined through negotiation between the manufacturer and the FAA. Consequently, there is a wide variation in the results of these evaluations, not only from manufacturer to manufacturer, but between a single manufacturer's product lines. No regulations exist addressing the concept of the CAWS or the level of criticality of warning systems. The Safety Board believes that the determination and dissemination of guidance for the design of CAWS would be beneficial in the certification and operation of future transport airplanes.

The Safety Board also notes that some DC-9 82 operators have changed their checklist procedures. Flightcrews on these carriers are now required to check the performance of the takeoff warning system before every flight. While this procedure will verify the status of the takeoff warning system and the CAWS power supply-2, it will not apprise the flightcrew of a subsequent failure nor will it alert them of input power losses to the other power supplies of the CAWS.

The takeoff warning system alerts the flightcrew to an existing fault. It is the flightcrew's duty and responsibility to configure the airplane for takeoff and to ensure that they have done this correctly. Therefore, the Safety Board sought to determine why the flightcrew had not accomplished this basic task.

2.6 Flightcrew Checklist Performance

The CVR recording showed that the flightcrew neither called for nor accomplished the TAXI checklist. The first item on the TAXI checklist required both pilots, in response to the checklist's challenge, to check and verify orally that the flaps and slats were positioned correctly. This item was not performed, and the flightcrew did not discover that the airplane was configured improperly for takeoff. The omission of the TAXI checklist was further corroborated by the flightcrew's inability to engage the autothrottles at the start of the takeoff because they did not, as required by the TAXI checklist place the TCI in the "T.O." mode. However, they were able to rectify this omission by the time the airplane accelerated to 100 KIAS. Once the takeoff began, however, there was little chance they would detect any of the visual cues--the flap indicators in the up position, the absence of the blue takeoff light on the slat indicator light panel, and the absence of the ART ready light--that might have alerted them to the fact that the airplane was not configured properly. All of the visual cues relating to the flaps and slats were located outside, or on the perimeter of, those areas normally monitored by the captain and the first officer during takeoff. The Safety Board concludes that the failure of the flightcrew to accomplish the TAXI checklist in accordance with required procedures was the probable cause of this accident. Therefore, the Safety Board sought to determine how this omission could have occurred.

The Safety Board could not determine conclusively why the first officer did not lower the flaps. Northwest procedures authorized first officers to extend the flaps after the airplane begins to taxi and has cleared the parking ramp and its associated obstacles. The CVR recording showed that at the time the first officer was authorized to extend the flaps, several intervening events might have diverted his attention. Almost immediately after receipt of the taxi clearance and about the time the airplane began moving, the first officer had to select the ATIS radio frequency and listen to and copy the contents of the ATIS message. After receiving the message, he then had to get the takeoff performance chart and verify if they could use runway 3C for takeoff. Thus, the possibility existed that he might have intentionally delayed lowering the flaps, perhaps anticipating a different flap setting due to the runway change. The testimony of and interviews with Northwest flight personnel indicated that the flap extension procedure had become a very strong habit pattern among the DC-9 first officers. As such, the first officer may never have experienced an occasion when he had either

inadvertently failed to extend flaps or had failed to extend them when the airplane began taxiing. The habit pattern of extending the flaps may have caused a lessening of his awareness of the omission, because by the time the first officer completed copying the ATIS message and analyzing the takeoff weight data, the airplane had taxied well beyond the point where he would have routinely extended the flaps. Based on this well developed habit pattern of extending the flaps, the first officer might have believed that this task, which was always completed shortly after the captain began to taxi or by the time the airplane departed the terminal ramps, had been completed as it always was.

The flap extension procedure did not require the captain to be either notified or to approve repositioning the flaps and slats. Therefore, unless he happened to either observe the first officer move the flap handle, or observe the movement of the flap indicator or the illumination of the slat advisory lights, he would not know that the procedure had been accomplished. In addition, the same habit pattern concerning the flap extension procedure would apply to the captain. Since there was no requirement to advise him, it was even more likely that he would assume that the first officer had extended the flaps at the place and time that they had always been extended. Consequently, the TAXI checklist became the only procedural means available to the flightcrew to ensure that the airplane was configured properly.

Northwest procedures defined clearly the flightcrew's duties and responsibilities as to how checklists were to be initiated and completed. During ground operations, the captain is to initiate each checklist by calling for it by name; if the captain does not call for the checklist, the first officer is required to ask the captain if he is ready to run the checklist. This procedure establishes a positive entry into a checklist for both crewmembers and provides crew backup to the memory-based initiation of a checklist. This design is particularly critical in initiating the TAXI checklist on which the flaps are the first item since the actual lowering of the flaps is solely the first officer's responsibility. After each checklist is completed, the first officer is required to identify the checklist by name and state that it was "complete." The statement that a specific checklist is complete provides closure to checklist conduct by acknowledging checklist completion. This statement enables both crewmembers to mentally move from the checklist to other areas of the operation with the assurance that the checklist has been accomplished. These requirements were met only once during the pretakeoff checklists. The closest approach to these standards was the BEFORE START checklist. At 2029:10, the first officer challenged "Brakes," the first item on this checklist. The captain did not respond to the challenge; however, at 2029:18, the captain said, "Lets do the checklist." At 2032:54, the first officer announced, "The BEFORE START checklist is complete." However, even within the performance of this checklist, there were failures to comply with company standard procedures. Checklist items which require actions by and responses from the captain were read and responded to by the first officer. The captain did not call for the AFTER START, TAXI, or BEFORE TAKEOFF checklists, nor did the first officer ask the captain if he was ready to perform any of these checklists before reading the items.

The Safety Board believes that the design of the checklist procedures establishes a process wherein both crewmembers actively participate in checklist initiation. When by manner of practice, the captain yields his responsibility for checklist initiation, or the first officer actively or aggressively takes sole responsibility for checklist initiation, the redundancy afforded by mutual checklist entry is eliminated. By not adhering to the procedural framework, the crewmembers compromised the structure which was designed to support them and thereby placed a greater burden on the memory or habit pattern of an individual crewmember, in this case the first officer. This breakdown rendered the crew more susceptible to distractions or memory lapses.

The Taxi Checklist.--The Safety Board believes that the initiation of the TAXI checklist presented a problem to the flightcrew that did not exist with regard to the other checklists which are performed during ground operations before takeoff and which all have fairly definite keys or

sequences that the crewmember can use to initiate the checklists. Two of these checklists, the BEFORE START and BEFORE TAKEOFF, constitute a condition precedent which must be eliminated before further airplane operations can be conducted. The BEFORE START checklist can be keyed by the final closing of the cabin door; the AFTER START checklist is cued by the completion of the last engine start; and, the BEFORE TAKEOFF checklist has the runway hold short line or the flight's takeoff sequence as cues. By contrast, the TAXI checklist can reasonably be initiated and accomplished any time after the captain begins to taxi or during any phase of ensuing taxi to the takeoff runway.

Testimony from other Northwest flightcrew members showed that they usually complete the TAXI checklist within the first 1 to 2 minutes of taxi. However, during this time they are also establishing radio contact with ATC, being sequenced with other traffic, and receiving other ground control instructions. All of these factors are potential distractors or delayers of the checklist. Therefore, crew-coordination and work-load management play a vital role in the accomplishment of both routine and intervening tasks that occur during taxi. The Safety Board believes that the nonstandard manner in which the crew initiated checklists, with the first officer bearing the load for checklist initiation and accomplishment, increased the crew's vulnerability to the problems associated with conducting checklists during taxi operations.

Since the TAXI checklist was almost always performed early in the taxi operation, it is possible that the flightcrews become conditioned to having completed the checklist by the time the flight has taxied for more than a few minutes. If there are interruptions and the checklist has not been initiated normally, when the airplane reaches a point in the taxi where the TAXI checklist typically has been completed, it is possible that the flightcrew will believe that the checklist was completed.

The captain and first officer on flight 255 had accomplished those items on the TAXI checklist which could be completed upon receipt of the final weight, such as stabilizer trim, airspeed settings, and the insertion of the c.g. and takeoff flap setting into the takeoff condition computer. At 2036:37 and 2036:40, while the airplane was taxiing, the CVR recording contains two comments concerning takeoff speeds and trim settings, the third and second items, respectively, on the TAXI checklist. The Safety Board's CVR group could not identify who made the 2036:37 comment, but the captain made the second comment. It is possible that the first officer and captain were either in a preparatory stage preceding the initiation of the TAXI checklist or were updating what they thought was a completed checklist. However, immediately thereafter, the captain questioned whether runway 3C could be used for takeoff and taxied past taxiway Charlie precipitating an almost 2-minute digression from matters relevant to the checklist. By this time the airplane's location on the airport was such that the external cues and references available to the flightcrew were not those normally associated with the initiation of the TAXI checklist at Detroit-Metro. In fact, with reference to the time of taxi and the airplane's location, the flightcrew had progressed into a frame of reference where the TAXI checklist would have been completed. Since no further action was taken concerning any other TAXI checklist items, the Safety Board believes that by this time, the flightcrew thought the checklist had been completed.

The Safety Board recognizes that the TAXI checklist must, at times, either be initiated or accomplished while flightcrews are establishing radio contact with ATC, taxiing through congested ramp areas, being sequenced with other taxiing airplanes, and receiving other ground control instructions. All of these factors are potential distractors and may even reach levels which may require a captain to delay initiating the checklist. The sequence of events involving flight 255's departure from Detroit indicated that these and other potentially distracting factors were present. The flight was operating behind schedule with the crew facing a curfew problem for their arrival in Santa Ana. Weather in the local area could have caused further delay if the storm arrived before their departure. There were reports of windshear by other crews and ATIS "hotel" windshear

advisories. The runway change required the first officer to reference the takeoff performance manual.

The Safety Board believes that while the occurrence of these events presented the crew with distractions in addition to routine duty requirements, none represented extraordinary circumstances. The flightcrew was competent, qualified, highly experienced, and well regarded in their abilities by their peers. As such, none of the events they encountered should have been new to them and were circumstances with which they had successfully dealt in the past. While it is apparent that some combination of these events induced sufficient disruption to cause inadvertent omissions by a flightcrew using nonstandard procedures, the Safety Board sought to determine if other procedural areas might have contributed to flight 255's flightcrew's failure to perform the TAXI checklist.

Cockpit Discipline.-- A NASA psychologist testified that a well defined role structure in the cockpit reduces ambiguity about each crewmember's responsibility and when he will do it. He testified that the "lack of a well defined role structure is as devastating as one that is overly strong." The statements indicated that he believed there is a middle ground which the crew must occupy in effecting the desirable aspects of role or command structure. Too many commands or commands issued in a too authoritarian manner may inhibit crew effectiveness.

The psychologist testified that based on his observations of flightcrew performance during the simulator flights, he found, in general, that "commands were associated with a lower incidence of flying errors . . . and often communications of this type seem to assure the proper delegation of cockpit duties and facilitate coordination and planning."

The Safety Board believes that it is the captain's responsibility to structure the manner in which his crew will accomplish its duties. While he must be open to information input from his crew, he must set the tone for how this information will be proffered. Except for the BEFORE START CHECKLIST, he did not call for any of the other checklists nor did he point out to the first officer that checklists were not being accomplished in accordance with company procedures. After pushback, the captain initiated three conversations which were not germane to duty requirements and which diverted the crew's attention from task-related activities.

The evidence indicated that the first officer was either given, or assumed he had been given, the duties of leading the crew's task-related activities up to and including the signing of the flight release, a responsibility assigned to the captain by regulation. ^{12/} While it is possible the captain intended to discuss this problem with the first officer, he made no move to point out to the agent, for the agent's future knowledge, that only the captain is authorized to sign the release. The first officer's assumption of the role of leader placed him in a position of structuring the crew's approach to activities while at the same time trying to satisfy the captain that he was carrying out his subordinate role in a satisfactory manner. In the area of checklist initiation, the first officer's assumption of initiation responsibilities greatly increased his work and planning load and relegated the captain's function to that of observer. The evidence also indicated that deference by a captain to a first officer also can inhibit crew effectiveness because the captain cannot presume that the first officer will always assume all of the captain's responsibilities. The captain appears to have become dependent upon checklist initiation by the first officer instead of on his own active initiation

^{12/} Title 14 CFR 121.663 states in part, "The pilot in command and an authorized dispatcher shall sign the release only if they both believe the flight can be made safely."

responsibilities. Therefore, when the first officer became distracted, the captain's passive involvement with checklist initiation did not provide a backup to the first officer's memory.

An examination of the flightcrew's performance patterns during the flight into Detroit and during their departure from the terminal and taxi to the takeoff runway showed numerous examples of less than standard performance.

- After landing at Detroit-Metro, the flightcrew taxied by the entrance to their assigned gate and had to turn 180° to return to the gate.
- The airplane's weather radar is normally turned off during the AFTER LANDING checklist which is normally accomplished shortly after clearing the active runway. However, flight 255's weather radar was still on when the airplane was in proximity to the gate and after a lengthy taxi. While the possibility existed that the flightcrew intentionally did not turn the radar off, the greater possibility was that the flightcrew had not yet performed the checklist or had missed turning it off during the performance of the checklist.
- During the taxi-out at Detroit-Metro, ground control directed the crew to taxi to runway 3C, to change radio frequencies, and to contact ground control on the new radio frequency. The first officer did not change frequencies, and ground control was unable to contact the flight when it taxied past taxiway Charlie.
- The first officer had reiterated the ATC taxi clearance and route and the takeoff runway assignment to the captain at least twice. The captain did not question either the radio transmission or the first officer's reiteration of the transmission. Although the captain had flown to and from Detroit-Metro many times, he failed to turn off at Charlie and expressed doubt as to where it was located.

In essence, when these deviations are assessed together with the flightcrew's checklist performance, the Safety Board believes that their performance was below the standards of an air carrier flightcrew.

The Safety Board recognizes that human performance is subject to considerable change and variation and that flightcrews are not immune to having "off days" in which their performance is below the standards they have set for themselves and which others expect of them. Because factors which can contribute to substandard performance are often subtle, difficult to recognize, and individual in nature, crewmembers may not be aware of the reasons which underlie below-par performance. Management cannot monitor, on a daily basis, the individual's ability to deal with job requirements. It is for these reasons that standard operating procedures are developed. Applying these procedures as they are written provides a firm foundation on which they can depend for support. Routine operating procedures when applied in a disciplined, standardized manner provide crewmembers with a firm foundation which they can depend upon for support during those times when they are subject to less than optimum levels of performance. This support is provided when the crew fully recognizes the necessity to function as a coordinated team while applying routine procedures in a disciplined and standardized manner.

Flightcrew Standardization.--It was clearly evident in this accident that the flightcrew did not perform checklist procedures in the manner prescribed in the company's APH. There are two avenues of approach in analyzing the crew's nonstandard application of checklist procedures. Either

the crew was acting in a totally anomalous fashion or their performance was consistent with their routine behavior.

The captain gave no indication that he was uncomfortable with, or disapproved of, the first officer initiating checklists without his command or without first inquiring whether the captain was ready to start a particular checklist. The first officer's actions did not seem to generate any confusion on the part of either man and tends to indicate the checklists were being operated in a manner familiar to both of them and accepted by both as a proper alternative to standard company procedure. Had either been uncomfortable with this manner of operation one would assume that the aberrant actions by either crewmember would have been brought to the other's attention and corrected. This performance by two crewmembers whose performance was described by peers as standard, meticulous, and professional seems to indicate that this manner of checklist performance was one to which each had been exposed and become familiar with over a lengthy period. For the flightcrew to gain the level of comfort and acceptance which was demonstrated indicates that this manner of application was accepted and used by other crewmembers with whom they had flown.

The Safety Board could not positively conclude that the performance of the accident crew was representative of the standards of performance used by a significant number of the carrier's flightcrews. Nor does the Safety Board have direct evidence to support the contention that this type of nonstandard performance is an industry-wide problem. Nevertheless, the Safety Board recognizes there are similarities between Northwest and the published operational procedures, aircraft, and checklist concept used by many air carriers. Therefore, the Safety Board believes that the FAA should require its operations inspectors and designated check airmen to emphasize the importance of disciplined application of operating procedures and rigorous adherence to prescribed checklist procedures. The Safety Board also believes that the standards and procedures used by the management of carriers cited in the Boeing Airliner Magazine are indicative of procedures that would foster an improved degree of standardization and safety.

The Safety Board believes that the use of company check airmen has advantages in that it expands the surveillance of the FAA and, as structured within the former Republic Airlines organization, serves as quality control to the training department. Check airmen are selected by management based upon their high level of professional performance and are given ground school and specialized training before designation by the FAA. Evidence indicates that the company had established a program to address standardization of crew performance. The Safety Board believes, however, that check airmen are also susceptible to erosion of standardization. Procedural differences that are subtle and which demonstrate no readily apparent flaw may lead to a check airman's loss of sensitivity to the relaxation of adherence to standards or at least prompt hesitancy in correcting such crew performance. While this loss of sensitivity may have existed within the check airmen of the company, the Safety Board does not view this as an indictment of the concept of the check airman program. The Safety Board believes that the program is necessary and is successful because of the air carrier's self interest in conducting safety operations.

Checklist Presentation.--While the applicable regulations require that carrier furnish checklists to their flightcrews and establish procedures for using the checklist, the regulations do not establish how the information contained on the checklist is to be presented. Some carriers present their checklists on an 8- by 11-inch laminated card; each side of the card contains several sections of the checklist. The U.S. Air Force presents the checklists of its Lockheed C-141s and C-5s on scrolls. After completing the items in view on a lubber line in the window of the scroll case, the user rotates the scroll to position the next checklist item on the lubber line for accomplishment. One U.S. carrier uses the laminated card to present all but its before takeoff and landing checklists; the carrier presents these two checklists on a mechanical slide checklist. As each item on the mechanical checklist is completed, a slide is moved over and covers the completed item. In later model airplanes, the checklist is displayed electrically. When the desired checklist is selected, all items on the list are

illuminated. As the checklist item is completed, a switch is moved and the light beneath the completed item is extinguished. Both the mechanical and electrical checklists are affixed permanently to the cockpit structure.

The Northwest DC-9-82 checklist is printed on a 6 3/4- by 11-inch card which is divided into thirds by dashed lines. When folded, one section of the card includes the TAXI, DELAYED ENGINE START, BEFORE TAKEOFF, CLIMB, and IN RANGE checklists. During the accident flight operational sequence, after completing the AFTER START checklist, the flightcrew would have had to turn over the card and would have had to affix it to the control wheel to expose the TAXI checklist.

The presentation and organization of the checklist card does not, of itself, allow visual differentiation between accomplished and nonaccomplished checklists. The TAXI and BEFORE TAKEOFF checklists are arranged in sequential order of operations and, as such, the checklist card requires no manual manipulation to transfer attention from one checklist to the other. Also, the checklist card does not provide a visual alert to a nonaccomplished checklist.

The presentation on the Northwest checklist does not differ in any substantial degree from the checklist presentations by other carriers on 8- by 11-inch laminated cards. Both presentations require some manipulation because all of the checklists cannot be presented legibly on one side of the card. Although the places where manual manipulation on each chart is required may differ, neither presentation requires manual manipulation to transfer attention from each individual checklist segment to another and neither provides a visual alert to a nonaccomplished checklist.

The evidence developed during the Safety Board's investigation showed that adherence to flightcrew procedures is paramount in accomplishing a checklist properly. The testimony of the NASA psychologist corroborated this conclusion as did that of the management sciences professor.

However, the management sciences professor testified that he "did not know of any human factors research on how a checklist should be designed and he could not find anything in his library on the subject." The Safety Board believes that the facts and circumstances of this accident contain compelling reasons for conducting human performance research on checklist presentation. The Safety Board believes that the FAA should convene a human performance research group of personnel from NASA, industry, and pilot groups to determine if there is any type or method of presenting a checklist which produces better performance on the part of user personnel.

2.7 Training

The Safety Board notes that both crewmembers received single-crewmember training during their last simulator training and proficiency checks. When such training is performed, the instructor occupies the other pilot seat and also operates the simulator. The Safety Board believes this manner of training significantly limits the opportunity for the instructor to observe and to critique nonstandard practices because he is part of the operating process. The Safety Board realizes that providing recurrent training to captains and first officers separately was not the policy of the Northwest Airlines DC-9-82 training department. Rather, the single-crewmember training sessions for the captain and first officer of flight 255 occurred as a result of nonroutine scheduling difficulties or other unforeseen circumstances. When training is conducted using a complete crew, the instructor is able to observe the manner in which the two crewmembers perform their duties. By observing the interaction of the crew, the instructor is better able to identify problems relating to communication, checklist usage, and standardization.

Historically, the industry in general, and the FAR's in particular, have emphasized during training and proficiency checks individual piloting skills as a measure of performance. This emphasis on individual performance pays insufficient attention to the importance of the crew functioning as a team. The Safety Board believes that training individuals to an individual level of performance does not necessarily provide for an effective, coordinated cockpit team.

The Safety Board believes line-oriented flight training (LOFT) and training in the management of crew coordinated activities provides the opportunity to more fully train flightcrews in a team-oriented manner. LOFT focuses the training environment on the conduct of the entire crew; as such, it expands the training incorporated during the performance of individual maneuvers. Training crewmembers in management and communication skills will expand the crew's ability to more effectively coordinate information processing requirements.

Since 1968, the Safety Board has issued 22 recommendations to the FAA which addressed in varying degrees, cockpit resource management (CRM). On April 15, 1985, the Safety Board recommended that the FAA:

A-85-27

Conduct research to determine the most effective means to train all flightcrew members in cockpit resource management, and require air carriers to apply the findings of the research to pilot training programs.

The FAA, in its December 1986 response to Safety Recommendation A-85-27, stated it had:

Initiated a program in the area of Aviation Behavioral Technology which is intended to develop and apply advanced behavioral analysis and technology to improve flight safety. The program includes projects on optimized line-oriented training to enhance cockpit resource management, improve cockpit/cabin communication and coordination, and improved pilot decision making training program.

The FAA further commented that this program would be a "long-term effort."

The Safety Board supports these efforts of the FAA and hopes that a priority will be given to this program that will allow its benefits to be incorporated in air carrier training programs as expeditiously as possible.

While the Safety Board believes there are benefits to be derived from any meaningful discussion on CRM, it also believes there is evidence that would indicate CRM training given solely in a quasi-classroom environment with diminished frequency will not provide to flightcrews the appropriate emphasis and hence the long-term follow through that is intended.

Republic Airlines began training crews for CRM in the fall of 1983. It was presented in the recurrent ground school and was followed with instruction presented in Recurrent Training Bulletins (RTB) 83-3 and 83-4, and each RTB in 1984.

The flightcrew members on the accident flight received 3.5 hours of CRM training during their respective ground schools (general) in 1983. This was the last CRM training that each crewmember received.

The Safety Board believes that the absence of leadership and coordination demonstrated by the accident crew suggests there is strong evidence to support that the CRM training they did

receive was deficient and that future programs must go beyond the scope of a limited and traditional classroom forum.

The Safety Board is aware that the Republic Airlines training program will be integrated into the Northwest Airlines training program. The carrier thus has the opportunity to assure that flightcrew coordination, cockpit resource management, and standardization of operational procedures will be given adequate emphasis during training.

2.8 Automated Systems Use

The Safety Board found no indication that the flightcrew's failure to configure the airplane for takeoff was attributable to their reliance on an automated system which would warn them of their omission. The Safety Board's concern over this matter was aroused when Northwest flightcrews testified that some DC-9-82 crews used the takeoff warning system to check their airplane configuration while taxiing out for takeoff. Pilots stated that during taxi and after the airplane has been configured for takeoff, one or more throttles are sometimes advanced to see if the takeoff warning annunciates. If there is no warning, they assume the airplane to be configured for takeoff. The evidence showed that this practice was brought about by the sensitive relationship of the airplane trim setting to the adjustable center of gravity index. Crewmembers stated that they had experienced occasions when the trim setting appeared to be set properly but was apparently misset a slight amount causing the takeoff warning to sound when power was applied for takeoff. When this occurred on the runway, the crew would have to reject the takeoff, exit the runway, and delay departure while they analyzed the cause of the problem. Therefore, to preclude this late discovery, flightcrews began checking for a warning before taking the active runway. A Northwest check airman stated that he recommended this procedure to flightcrews during line checks.

While the use of this procedure to check specifically for a slightly-out-of-tolerance trim setting before starting a takeoff may be good, the Safety Board is concerned that the practice may cause flightcrews to believe that they are also performing a functional check of the takeoff warning system when, in fact, they are not. If the takeoff warning system had failed as it did in the accident flight then regardless of the airplane configuration, the flightcrew will receive no warning. Operation of the takeoff warning system can only be checked properly by performing the functional test contained in the checklist or by advancing the throttles beyond the throttle switches with a known parameter out-of-tolerance.

2.9 Flightcrew Actions After Takeoff

Even though the Safety Board determined that the flightcrew failed to configure the airplane properly for takeoff, the Safety Board examined the flightcrew's actions after takeoff to see if they could have prevented the accident.

By the time the airplane lifted off, the captain had rotated it to a 11° to 12° nose-up pitch attitude. The stick shaker activated at liftoff and continued to operate throughout the flight. After liftoff, the captain rotated the airplane to a 13° to 14° noseup pitch attitude, and, 4.5 seconds after liftoff, the SSRS alarm activated and the airplane began to roll. The subsequent rolls and control inputs required to recover from them decreased the airplane's climb capability by about 20 percent. Between the start of the first roll and initial impact, the airplane's pitch attitude varied between 13° to 14° noseup and these pitch attitudes were either at or just below the angle of attack which activated the SSRS.

The Safety Board's performance calculations showed that the airplane would have cleared the light pole if the roll oscillations were eliminated and the captain could have avoided them by lowering the nose of the airplane and maintaining a pitch angle that would have positioned it at or

just below the stick shaker's angle of attack. Given the configuration of the wing, flaps and slats retracted, the stick shaker would have initiated at an angle of attack of about 11° , 2° below the SSRS's angle of attack and below the angle of attack at which the airplane's roll stability was compromised. Had the captain flown the airplane at a constant 11° angle of attack, he would have avoided the roll oscillations and the airplane would have cleared the light pole by about 80 feet.

Three Northwest DC-9-82 captains stated that, during an encounter with a windshear, they would consider flying the airplane above the pitch angle that would cause the SSRS to begin. They stated that the airplane was not stalled at that pitch angle. One of these captains stated that he "would not be completely uncomfortable in the supplementary stall warning region if necessary for recovery." Although the captain of flight 255 flew the airplane at and just below the angle of attack which activated the SSRS warning, there was no evidence to indicate that the captain of flight 255 entertained similar conclusions as to the airplane's performance capabilities in this flight regime.

The evidence does not provide a sufficient basis for the Safety Board to conclude that his entrance into this area of flight was intentional. The airplane lifted off the runway with the stick shaker activated and at about a 11° to 12° noseup pitch attitude. To silence the stick shaker, the captain would have had to release the back pressure on the control column and allow the nose to lower about 2° . Given the facts that the airplane had just taken off, that its climb rate was virtually negligible, and that the stick shaker was operating continuously, the Safety Board believes that it would be almost impossible to expect the captain to introduce control inputs which threatened to reverse the airplane's negligible rate of climb. Throughout the entire flight, the airplane was operating in proximity to the ground. The Safety Board believes that one possible explanation for the manner in which the airplane was flown was that the control inputs of the captain were merely a reflex action on his part to avoid recontacting the ground.

Any evaluation of the captain's flight techniques must start with a conclusion as to what the captain and first officer believed the configuration of the airplane was. Since they both believed that the airplane was configured as required for takeoff before they began the takeoff, the fact that the takeoff warning did not sound in accordance with their expectations would have further reinforced their belief that the flaps were at 11° and that the slats were extended to the mid-sealed position. During the time they had been in the airplane, there had been numerous communications concerning windshear and microbursts in proximity to the airport. Also, thunderstorms, which might reinforce the possibilities of windshear or gust were in sight north and west of the airport. When the immediate nature and strength of repetition, both verbally and visually, of the possibility of windshear is combined with the reasons for the crew's belief in a properly configured airplane, the Safety Board believes that it is reasonable to conclude that the flightcrew thought they had encountered a windshear when the stall warnings began after liftoff and focused their attention on escaping from a windshear encounter. Windshear recovery procedures do not call for a configuration change. Instead, they call for power and attitude adjustments to prevent the airplane from striking the ground and, thereafter, to try and establish a rate of climb. The DFDR indicated that the captain was trying to maximize the performance of the airplane with pitch attitude adjustments. In addition, the rolling of the airplane also would have been indicative of the type of turbulence that can accompany a low altitude windshear or microburst. The fact that the pitch adjustments exceeded those recommended for use during windshear encounters and placed the airplane at angles of attack which activated the SSRS alarm could be attributed to reflex actions by the captain to clear the oncoming light poles.

The stall recovery procedures contained in the Northwest APH stated, in part, that if a stall were encountered with the airplane configured for takeoff the pilot flying the airplane should apply and call "Max power, flaps 15" while simultaneously relaxing the back pressure enough to stop the stick shaker or buffeting. The pilot not flying will select the flaps and trim the throttles to maximum power. The DFDR recording indicated that maximum power was applied; however, the CVR showed

that the captain did not call for the flaps to be set to 15°. The fact that the captain did not try to use this procedure could further indicate that he believed he had encountered a windshear.

The total amount of time that the airplane was flyable was 14 seconds. Even if the crew had recognized that the increasing airspeed was inconsistent with a decreasing performance windshear, the short period of time for them to completely and accurately assess what was happening to the airplane was probably inadequate. The combination of airplane rolling, the stall warnings, and the possibility of imminent ground contact were probably powerful enough stimuli to focus the crew's attention completely on the factors relevant to avoiding ground contact and to maintaining airplane control and did not allow them sufficient flexibility to expand their attention to include all the factors that were required to more completely assess the airplane's condition.

The Safety Board believes that the captain's bracketing of the SSRS alarm was a reflexive action to the adverse visual cues presented to him. However, the continued operation at the higher SSRS angle of attack instead of the stick shaker angle of attack resulted in the onset of roll oscillations and the loss of critical climb capability.

All DC-9 series airplanes that have leading edge wing slat systems are equipped with an SSRS. The SSRS system is unique in that it provides an indication of the stall angle of attack; therefore, it may lead to over-confidence while operating above the normally accepted upper limit of stick shaker angle of attack. The Safety Board found that some DC-9-82 captains expressed no concern about operating at the SSRS angle of attack. Only one captain who was interviewed stated that "he would not try to go into the supplementary stall warning area." It appears that some captains did not recognize the SSRS as an announcement of stall. They viewed the SSRS alarm as a warning with some margin as is the case with the stick shaker where there is a margin. In addition, these captains expressed no concern about the loss of lateral control at SSRS and the resultant degradation of climb performance procedure taught by most airlines for windshear. Actually, the crew were maintaining pitch at or near the SSRS and should have been maintaining a lower angle at stick shaker.

The possible reasons for these beliefs about the SSRS are either that training is inadequate or that the simulators do not accurately model the decreased roll stability at angles near to or greater than the SSRS angle of attack, thus giving a false sense of security. MD-80 flightcrews should be trained on the lateral control hazards that exist while operating at the SSRS angle of attack and the fact that the additional climb performance capability that exists above the stick shaker angle of attack is minimal and easily negated when small roll oscillations commence. MD-80 pilots should be trained to operate at or below the onset of stick shaker activation and to avoid the activation of the stick shaker except in those conditions beyond their control.

The Safety Board cannot determine if the selection of the go-around mode resulted from an inadvertent actuation of the TOGA switch when the captain advanced the throttles after liftoff or whether the TOGA switch was activated intentionally. However, there is no normal, abnormal, or emergency procedure in the Northwest APH which recommends that the F/D be transferred from the takeoff mode to the go-around mode under the conditions of flight that existed when the transfer occurred.

The simulations of the F/D's theoretical design performance for the condition of the accident takeoff demonstrated that, had the F/D remained in the takeoff mode and had the captain been able to follow the guidance provided by the command bar, the airplane theoretically would have been flown at pitch attitudes below the stick shaker's angle of attack. Flight in this regime would have increased the airplane's roll stability. Consequently, the airplane's climb performance would not have been degraded by roll oscillations and spoiler deflections and the airplane would have cleared the light pole.

2.10 The Captain's Hearing

The captain's hearing aid was fitted for his left ear, the same ear that he would have used for his radio receiver. The captain's hearing aid was not found at the accident site, and it was also doubtful that he would have used the hearing aid at the same time he would have worn the radio receiver's molded ear piece. Therefore, the Safety Board concludes that the captain was probably not wearing his hearing aid at the time of the accident.

Examination of the CVR transcript showed a few instances where the captain appeared not to have heard either a radio transmission or an intracockpit remark; however, the instances are separated widely and no pattern of consistency that could be attributed to a hearing deficiency was discernible.

3. CONCLUSIONS

3.1 Findings

1. Flight 255 did not encounter windshear either during the takeoff roll or after liftoff.
2. Flight 255 took off with its wing's trailing edge flaps and leading edge slats retracted.
3. The flightcrew did not extend the airplane's flaps and slats.
4. The flightcrew did not perform the airplane's checklists in accordance with the prescribed procedures contained in the Northwest Airplane Pilots Handbook. The flightcrew did not accomplish the TAXI checklist and therefore did not check the configuration of the airplane.
5. The airplane's climb performance was severely limited by the flightcrew's failure to properly configure the wing for takeoff.
6. The airplane would have cleared the light pole by 500 feet with only its wings slats extended.
7. The roll stability of the airplane was decreased as a result of flying it at or below the SSRS alarm and near the stall angle of attack. The resultant rolling of the airplane degraded its climb performance.
8. If the airplane had been flown at or below the stick shaker angle of attack, the roll stability would have been increased and the airplane would have cleared the light pole.
9. The CAWS unit's takeoff warning system was inoperative and, therefore, did not warn the flightcrew that the airplane was not configured properly for takeoff.
10. The failure of the takeoff warning system was caused by the loss of input 28V d.c. electric power between the airplane's left dc. bus and the CAWS unit.
11. The interruption of the input power to the CAWS occurred at the P-40 circuit breaker. The mode of interruption could not be determined.

13. The light poles at the impact site did not exceed the limiting standards contained in 14 CFR Part 77.

3.2 Probable Cause

The National Transportation Safety Board determines that the probable cause of the accident was the flightcrew's failure to use the taxi checklist to ensure that the flaps and slats were extended for takeoff. Contributing to the accident was the absence of electrical power to the airplane takeoff warning system which thus did not warn the flightcrew that the airplane was not configured properly for takeoff. The reason for the absence of electrical power could not be determined.

4. RECOMMENDATIONS

As a result of its investigation, the National Transportation Safety Board made the following recommendations:

--to the Federal Aviation Administration:

Conduct a directed safety investigation to determine the reliability of circuit breakers and the mechanisms by which failures internal to the circuit breakers can disable operating systems and to identify appropriate corrective actions as necessary. (Class II, Priority Action) (A-88-64)

Require the modification of the DC-9-80 series airplanes to illuminate the existing central aural warning system (CAWS) fail light on the overhead annunciator panel in the event of CAWS input circuit power loss so that the airplane conforms to the original certification configuration. (Class II, Priority Action) (A-88-65)

Develop and disseminate guidelines for the design of central aural warning systems to include a determination of the warning to be provided, the criticality of the provided warning, and the degree of system self-monitoring. (Class II, Priority Action) (A-88-66)

Require that all Parts 121 and 135 operators and principal operations inspectors emphasize the importance of disciplined application of standard operating procedures and, in particular, emphasize rigorous adherence to prescribed checklist procedures. (Class II, Priority Action) (A-88-67)

Convene a human performance research group of personnel from the National Aeronautics and Space Administration, industry, and pilot groups to determine if there is any type or method of presenting a checklist which produces better performance on the part of user personnel. (Class II, Priority Action) (A-88-68)

Expedite the issuance of guidance materials for use by Parts 121 and 135 operators in the implementation of team-oriented flightcrew training techniques, such as cockpit resources management, line-oriented flight training, or other techniques which emphasize crew coordination and management principles. (Class II, Priority Action) (A-88-69)

training, or other techniques which emphasize crew coordination and management principles. (Class II, Priority Action) (A-88-69)

Issue an Air Carrier Operations Bulletin-Part 121 directing all principal operations inspectors to emphasize in MD-80 initial and recurrent training programs on stall and windshear recovery the airplane's lateral control characteristics, potential loss of climb capability, simulator limitations, and flight guidance system limitations when operating near the supplemental stall recognition system activation point (stall angle of attack). (Class II, Priority Action) (A-88-70)

--to all Part 121 Air Carriers:

Review initial and recurrent flightcrew training programs to ensure that they include simulator or aircraft training exercises which involve cockpit resource management and active coordination of all crewmember trainees and which will permit evaluation of crew performance and adherence to those crew coordination procedures. (Class II, Priority Action) (A-88-71)

BY THE NATIONAL TRANSPORTATION SAFETY BOARD

/s/ JIM BURNETT
Chairman

/s/ JAMES L. KOLSTAD
Vice Chairman

/s/ JOHN K. LAUBER
Member

/s/ JOSEPH T. NALL
Member

May 10, 1988

5. GLOSSARY

| | |
|-------------|--|
| ACDO | Air Carrier District Office |
| ADI | Attitude Director Indicator |
| AOA | Angle of Attack |
| AOL | All Operators Letter |
| APH | Airplane Pilot's Handbook |
| APM | Aircrew Program Manager |
| APU | Auxiliary Power Unit |
| ART | Automatic Reserve Thrust Unit |
| ATC | Air Traffic Control |
| ATIS | Automatic Terminal Information Service |
| ATS | Autothrottle System |
| | |
| CADC | Central Air Data Computer |
| CAM | Cockpit Area Microphone |
| CAWS | Central Aural Warning System |
| CFR | Code of Federal Regulations (when preceded and followed by numerals) |
| CFR | Crash, Fire, Rescue |
| CLMP | Clamp |
| CRM | Cockpit Resource Management |
| CVR | Cockpit Voice Recorder |
| | |
| DER | Designated Engineering Representative |
| DFDR | Digital Flight Data Recorder |
| DFGC | Digital Flight Guidance Computer |
| | |
| E&E | Electrical and Electronics |
| EPR | Engine Pressure Ratio |
| | |
| FAA | Federal Aviation Administration |
| F/D | Flight Director |
| FDAU | Flight Data Acquisition Unit |
| FMA | Flight Mode Annunciator |
| FMEA | Failure Mode and Effects Analysis |
| | |
| GA | GoAround |
| GCR | Group Code Recording |
| | |
| HEMS | Health Emergency Medical Services, Inc. |
| | |
| KIAS | Indicated Airspeed expressed in knots |
| | |
| LLWAS | Low Level Windshear Alert System |
| | |
| MEL | Minimum Equipment List |
| | |
| NASA | National Aeronautics and Space Administration |
| NOTAM | Notice to Airmen |
| NWS | National Weather Service |

GLOSSARY (cont'd)

| | |
|----------------|---------------------------------------|
| PIREP | Pilot Report |
| PMI | Principal Maintenance Inspector |
| POI | Principal Operations Inspector |
| PSEU | Proximity Switch Electronics Unit |
| SS | Stick Shaker |
| SSRS | Supplemental Stall Recognition System |
| TCC | Takeoff Condition Computer |
| TCI | Thrust Computer Indicator |
| T.O. | Takeoff |
| T.O. FLX | Takeoff Flex |
| TOGA | Takeoff Go-Around |

6. APPENDIXES**APPENDIX A****INVESTIGATION AND HEARING****1. Investigation**

The Safety Board was notified of the accident about 2100 eastern daylight time, August 16, 1987. A team of investigators was dispatched from Washington, D.C., and arrived on the scene at 0200, August 17, 1987. Investigative groups were formed for operations, air traffic control, witnesses, meteorology, survival factors, structures, powerplants, systems, digital flight data recorder, maintenance records, cockpit voice recorder, airplane performance, and human performance.

The parties to the investigation were the Federal Aviation Administration, Northwest Airlines, the McDonnell Douglas Corporation, Pratt & Whitney, the Air Line Pilots Association, the National Air Traffic Controllers Association, the International Association of Machinists, the International Brotherhood of Teamsters' Airline Division, the Wayne County Sheriff's Department, and the Detroit-Metro Wayne County Airport.

2. Public Hearing

A 4-day public hearing was held in Romulus, Michigan, beginning November 16, 1987. Parties represented at the hearing were the Federal Aviation Administration, Northwest Airlines, the McDonnell Douglas Corporation, and the Air Line Pilots Association.

APPENDIX C

CVR TRANSCRIPT

TRANSCRIPT OF A FAIRCHILD MODEL A-100A COCKPIT VOICE RECORDER
S/N 25334 REMOVED FROM NORTHWEST AIRLINES, MCDONNELL DOUGLAS DC-9-82 AIRCRAFT
WHICH WAS INVOLVED IN AN ACCIDENT AT DETROIT METRO WAYNE COUNTY INTERNATIONAL
AIRPORT ON AUGUST 16, 1987.

| | |
|-------|--|
| CAM | Cockpit area microphone voice or sound source |
| RDO | Radio transmission from accident aircraft |
| INT | Cockpit to ground intercom |
| PA | Cabin public address system |
| -1 | Voice identified as captain |
| -2 | Voice identified as first officer |
| -3 | Voice identified as male flight attendant |
| -4 | Voice identified as female flight attendant |
| -5 | Voice identified as female company gate agent |
| -6 | Voice identified as dead-heading company captain riding in the passenger cabin |
| -7 | Voice identified as company mechanic |
| -? | Voice unidentified |
| GND | Detroit Metro ground controller |
| TWR | Detroit Metro local (tower) controller |
| ATIS | Detroit Metro automatic terminal information service |
| RAMP | Northwest company ramp control |
| 1146 | Northwest flight eleven forty-six |
| 722 | Northwest flight seven twenty-two |
| 181 | Northwest flight one eighty-one |
| 102UM | Lifeguard one zero two uniform mike |
| 656 | Continental flight six fifty-six |
| 563 | Pan Am flight five sixty-three |

Appendix C

| | |
|-------|--|
| 5064 | Bluestreak flight fifty sixty-four |
| 752 | Northwest flight seven fifty-two |
| 185 | Northwest flight one eighty-five |
| 594CC | Citation five ninety-four charlie charlie |
| UNK | Unknown |
| * | Unintelligible word |
| @ | Nonpertinent word |
| # | Expletive deleted |
| % | Break in continuity |
| () | Questionable text |
| (()) | Editorial insertion |
| --- | Pause |
| NOTE: | All times are expressed in Eastern Daylight Saving Time. |

INTRA-COCKPIT

AIR-GROUND COMMUNICATIONS

TIME &
SOURCE

CONTENT

-1-

TIME &
SOURCE

CONTENT

20:13:27

(start of recording))

20:13:28

CAM-1

(I think it's control inputs more than anything)

20:13:40

CAM-1

yeah i got ** -- I got--

CAM-?

*

20:14:29

CAM-2

* go *

CAM-1

what's tower wind

20:14:33

CAM-2

I don't know

20:14:39

CAM-1

you could ah put these sigmets see you could punch in --OK
City -- just pull OK City up then you could put it
south south west it would be say about oh two hundred
and twenty degrees something like that punch in two
twenty forty miles make a way point and just connect
all the rest of the way points up and you can draw
you can draw the --

20:15:08

CAM-2

coordinates for the sigmet *

20:15:09

CAM-1

what ever they give you like what northwest makes the
crews plot on the maps you can do it right on the map

INTRA-COCKPIT

TIME &
SOURCE

CONTENT

20:15:18
CAM-2 turb plots I guess-

20:15:20
CAM-1 here's here's one I think we need ta -- ten
north northeast of Dubuque to twenty
southeast of ah Cedar City CID

20:15:33
CAM-2 Cedar Rapids

20:15:36
CAM-1- Cedar Rapids line of severe thunderstorms
twenty five wide moving from two sixty at
forty tops to forty five tornadoes hail
gusts to seventy

20:15:44
CAM-2 Oh maybe a little rain tonight huh

20:15:56
CAM-2 ((sound of humming))

20:16:02
CAM-2 Well ah --

20:16:08
CAM-3 I want to know when we're going--

20:16:11
CAM-2 Friday night we left here at twenty five
after we get --

-2-

AIR-GROUND COMMUNICATIONS

TIME &
SOURCE

CONTENT

Appendix C

INTRA-COCKPIT

TIME &
SOURCE

CONTENT

20:16:14
CAM-1 * Friday night *was it twenty five after

20:16:18
CAM-2 ya we're not gunna make that tonight

20:16:20
CAM-1 I don't think so

20:16:23
CAM-1 here's one forty south southwest of
LaCrosse to forty west of Cedar Rapids
--- and here's one twenty southeast of
Cedar Rapids to ten north northeast of Dubuque--

20:16:46
CAM-1 *

20:16:52
CAM-2 ((sound of yawn)) doesn't look like we're
gunna make Orange County tonight--

20:16:55
CAM-1 --Cedar Rapids oh there it is --

20:17:12
CAM-2 never make er to the County tonight---

20:17:29
CAM-6 John I made the last real seat in the
house I'm not gunna be ah keep'in you awake

-3-

AIR-GROUND COMMUNICATIONS

TIME &
SOURCE

CONTENT

Appendix C

INTRA-COCKPIT

| <u>TIME & SOURCE</u> | <u>CONTENT</u> |
|--------------------------|--|
| 20:17:32 CAM-1 | did you really - you got it |
| CAM-6 | you keep him awake |
| 20:17:35 CAM-2 | okay I'll do that |
| 20:17:36 CAM-1 | okay |
| 20:17:43 CAM-1 | ((sound of singing))-- okay south-- |
| 20:18:14 CAM-1 | forty south southeast of OK City |
| 20:18:18 CAM-1 | oh we've got to drive right through that one |
| 20:18:27 CAM-1 | OK City -- Kansas City |
| 20:18:32 CAM-2 | OK City is ah Will Rogers |
| 20:18:34 CAM-1 | yeah |
| 20:18:35 CAM-3 | let's let's go to LA - push for it |

-4-

AIR-GROUND COMMUNICATIONS

| <u>TIME & SOURCE</u> | <u>CONTENT</u> |
|--------------------------|----------------|
|--------------------------|----------------|

Appendix C

INTRA-COCKPIT

-5-

AIR-GROUND COMMUNICATIONS

| <u>TIME & SOURCE</u> | <u>CONTENT</u> |
|--------------------------|--|
| CAM-2 | right there it is isn't it near Will Rogers maybe |
| CAM-1 | * |
| 20:18:42 CAM-2 | that's Walnut Ridge Will Rogers yeah right over there |
| 20:18:49 CAM-1 | fifteen southeast of ah CDS what's CDS Cedar City |
| 20:18:57 CAM-2 | I don't know |
| 20:19:09 CAM-2 | CDS ah -- |
| 20:19:15 CAM-2 | ((sound of yawn)) Oh yeah let's get out of here before it starts raining |
| 20:19:21 CAM-1 | uh oh wasn't that a * |

| | |
|------------------|--|
| 20:19:13 1146 | ah ground this is eleven forty six we just landed on the right side there ah between five and three hundred foot we had a plus or minus twenty |
| 20:19:23 GND | okay thank you I'll just past it along |

INTRA-COCKPITTIME &
SOURCECONTENT

20:19:38
CAM-1 thats what a micro burst is you idiot

20:19:43
CAM-2 which way was it going-- the last I saw- it
was headed eastbound

20:19:46
CAM-1 ((sound of laugh))

20:19:50
CAM-2 at mach three

-6-

AIR-GROUND COMMUNICATIONSTIME &
SOURCECONTENT

20:19:25
1146 ((sound of mike key))

20:19:27
722 ground this is seven twenty two you just
had a micro burst out here on two seven
I don't know whether you saw it or not
but the dust just exploded down there

20:19:34
GND okay thanks which way was it going 8
there

20:19:36
722 every which way

20:19:38
GND okay

INTRA-COCKPIT

TIME &
SOURCE

CONTENT

-7-

AIR-GROUND COMMUNICATIONS

TIME &
SOURCE

CONTENT

20:20:08
CAM-1

what's CID

20:20:09
CAM-2

Cedar Rapids

20:20:10
CAM-1

forty west of Cedar Rapids it's not on the
map anyway

20:20:14
CAM-2

ah it's just west of Dubuque straight west
of Dubuque

20:20:20
CAM-1

that's Waterloo

20:20:22
CAM-2

well it's just a little south of Waterloo
southeast of Waterloo

20:20:25
CAM-1

oh here it is here it is

20:19:53

GND northwest seven twenty two when you make
the right turn on off plan to enter the
ramp at mike traffic southbound goin' to
be on the parallel

20:19:59

722 seven twenty two

INTRA-COCKPIT

TIME &
SOURCE

CONTENT

20:20:28

CAM-1

now I can't find it again

20:20:31

CAM-1

ten north northeast of Dubuque -- right there

20:20:41

CAM-1

twenty southeast of Cedar Rapids--

20:21:02

CAM-1

well you know what I'm gonna get you seen these little things I've seen them some place maybe on one of those racks or something that you can get a roll it looks like wax paper and it's got little stick 'em backs that are removable like Dennison labels and stuff

20:21:17

cam-2

uh huh

20:21:19

cam-1

get little green dots or red dots or something where those coordinates are just stick 'em on there and then you can take 'em off when you have time --okay there's that

20:21:35

cam-1

that's real close to Dubuque Des Moines like half way between Cedar Rapids and Des Moines is is this one --LaCrosse to Cedar Rapids

-8-

AIR-GROUND COMMUNICATIONS

TIME &
SOURCE

CONTENT

Appendix C

INTRA-COCKPIT

-9-

AIR-GROUND COMMUNICATIONS

| <u>TIME & SOURCE</u> | <u>CONTENT</u> |
|--------------------------|--|
| 20:21:52 CAM-2 | ((sound of blowing nose)) |
| 20:21:55 CAM-1 | okay |
| CAM-2 | excuse me |
| 20:21:56 CAM-1 | * LaCrosse LaCrosse- yo LaCrosse |
| 20:22:03 CAM-2 | ((sound of humming)) |
| 20:22:05 CAM-1 | Waukegan LaCrosse---there we go forty south southwest of LaCrosse about there and ah --- to twenty southeast of Cedar Rapids |

| | |
|-----------------|---|
| 20:22:12 181 | and ah ground northwest one eight one |
| 20:22:14 GND | northwest one eighty one ground |
| 20:22:15 181 | yeah has there been any hold on our departure to Waterville |

85

Appendix C

INTRA-COCKPIT

-10-

AIR-GROUND COMMUNICATIONS

Appendix C

TIME &
SOURCE

CONTENT

TIME &
SOURCE

CONTENT

CAM-2 well we're-- gonna be-

20:22:26

CAM-1 Jesus look at this

CAM-1 there is a line here a line between those two

CAM-2 unuha

20:22:33

CAM-1 and another one there

CAM-2 unha

20:22:36

CAM-1 about twenty five miles wide--okay we've got that one- we got that one

20:22:40

CAM-2 if we get out of here pretty quick-- we won't have a delay

CAM-1 we won't have to

20:22:18

GND negative none so far once that storm gets across here though there may be some delays over Waterville

20:22:23

181 okay

INTRA-COCKPIT

AIR-GROUND COMMUNICATIONS

-11-

| <u>TIME & SOURCE</u> | <u>CONTENT</u> |
|--------------------------|--|
| 20:22:43 CAM-2 | over Waterville but if we wait till after the storms (get/hit) here there will be delays goin' over Waterville |
| CAM-1 | yeah |
| 20:22:52 CAM-2 | well looks like bags are all in |
| 20:23:15 | ((46 seconds of nonpertinent social conversation between the Captain (CAM-1) and a flight attendant (cam-4))) |
| 20:24:01 CAM-2 | I guess she doesn't want to give me her clock number |
| 20:24:05 CAM-1 | @ |
| 20:24:10 CAM-1 | need need your clock number |
| 20:24:12 CAM-4 | oh five seven one zero didn't you remember my number |
| 20:24:16 CAM-2 | no |
| 20:24:17 CAM-4 | @ |
| 20:24:18 CAM-2 | I can't remember my own-- |

87

Appendix C

INTRA-COCKPIT

-12-

AIR-GROUND COMMUNICATIONS

Appendix C

| <u>TIME & SOURCE</u> | <u>CONTENT</u> |
|--------------------------|---|
| 20:24:20 CAM-2 | oh yeah I remember that now- it's all comin' back to me |
| 20:24:21 CAM-4 | first name @ |
| CAM-4 | yeah right |
| 20:24:23 CAM-2 | @ right |
| 20:24:24 CAM-4 | yeah right |
| 20:24:25 CAM-? | ((sound of laugh)) |
| 20:24:28 CAM-2 | continuing right |
| 20:24:29 CAM-4 | huh |
| 20:24:31 CAM-2 | continuing from a layover right |
| 20:24:32 CAM-4 | ah no no ya know I'm beginning and ending right |

INTRA-COCKPIT

-13-

AIR-GROUND COMMUNICATIONS

| <u>TIME & SOURCE</u> | <u>CONTENT</u> |
|--------------------------|--|
| 20:24:37 CAM-1 | she's beginning beginning from a layover |
| CAM-4 | beginning and ending |
| 20:24:41 CAM-1 | you layed over didn't ya |
| 20:24:43 CAM-4 | huh |
| 20:24:44 CAM-1 | you layed over here didn't ya |
| CAM-4 | no I'm based here |
| CAM-? | are you really |
| 20:24:46 CAM-4 | all I do is go to Phoenix and layover so I begin here and end here |
| CAM-1 | okay |
| 20:24:52 CAM-4 | and then tomorrow I bring it out of Phoenix to Memphis |
| 20:24:53 CAM-1 | you're on a layover in Phoenix then |

INTRA-COCKPIT

TIME &
SOURCE

CONTENT

20:24:56
CAM-2

beginning and laying

20:25:03
CAM-1

forty south southwest of OK City to fifty
southeast of what the hay is CES

20:25:06
CAM-2

no no idea

20:25:08
CAM-1

I bet that is Cedar City

CAM-2

yeah

20:25:22
CAM-4

you not gunna make Santa Anna tonight are you

20:25:25
CAM-2

doesn't look like it

20:25:26
CAM-1

probably LA

20:25:34
CAM-2

go to Memphis

20:25:40
CAM-1

why don't we just go to LA

-14-

AIR-GROUND COMMUNICATIONS

TIME &
SOURCE

CONTENT

Appendix C

INTRA-COCKPIT

AIR-GROUND COMMUNICATIONS

-15-

| <u>TIME & SOURCE</u> | <u>CONTENT</u> |
|--------------------------|--|
| 20:25:42 CAM-2 | naw they keep us in Phoenix and we do the Memphis Minneapolis deal-- |
| 20:25:45 CAM-4 | Memphis Minneapolis something something don't you - |
| 20:25:47 CAM-1 | unuha -- |
| 20:25:48 CAM-4 | Dallas Fort Worth-or something |
| CAM-1 | no we go ta go ta |
| CAM-2 | oh they could put us on that too-- Memphis Dallas |
| CAM-1 | naw we go to LA |
| CAM-4 | seemed to me that-- |
| 20:25:55 CAM-3 | John let's go to LA-- let's not let them do anything else to us |
| 20:26:00 CAM-2 | I don't think we do |
| 20:26:01 CAM-1 | they need the airplane over there |
| 20:26:02 CAM-? | * |

91

Appendix C

INTRA-COCKPIT

TIME &
SOURCE

CONTENT

-16-

20:26:05

CAM-4

some guy somebody told me that he had to do it

CAM-2

well what they do is they-they take this-this
plane over on the on the morning flight-

20:26:09

CAM-1

yeah but they need they got a seven o'clock
and an eight o'clock and this airplane

20:26:12

CAM-2

right there's one over there though there's one
already over there

20:26:15

CAM-1

yeah

20:26:16

CAM-2

and then they bring --

CAM-1

the other one doesn't even leave until eight
o'clock

CAM-2

ah-

20:26:19

CAM-1

they got to have two airplanes over there

20:26:21

CAM-2

I've seen 'em I've seen 'em do this

AIR-GROUND COMMUNICATIONS

TIME &
SOURCE

CONTENT

Appendix C

INTRA-COCKPIT

TIME &
SOURCE

CONTENT

-17-

20:26:22

CAM-1

because one - well then it's left late but -
I asked 'em the other night in Phoenix and he said
they just go to LA -normally

20:26:29

CAM-2

here's here's what they do

CAM-1

go to LA --

20:26:31

CAM-2

to get two airplanes over there do you want to know
how they do it --

20:26:34

CAM-2

we go into Phoenix there's another eighty sittin' there

CAM-1

right

20:26:36

CAM-2

that overnights in Phoenix

CAM-1

right

20:26:38

CAM-2

and they take that

CAM-1

cn out of there at eight o'clock in the morning

20:26:45

CAM-2

yeah so they take that crew and - and fly the
Orange County ah segment

AIR-GROUND COMMUNICATIONS

TIME &
SOURCE

CONTENT

INTRA-COCKPIT

-19-

AIR-GROUND COMMUNICATIONS

| <u>TIME & SOURCE</u> | <u>CONTENT</u> |
|--------------------------|--|
| 20:27:24 CAM-2 | is that right |
| 20:27:25 CAM-1 | uh huh |
| 20:27:27 CAM-2 | I've done -- |
| CAM-1 | (Ed) Trumble I was tellin' you about Trumble |
| CAM-2 | yeah |
| CAM-1 | that's what they did |
| 20:27:34 CAM-1 | I don't care if they want to do it that's fine |
| 20:27:36 CAM-2 | now can we go over there in the morning and do it -we'll need more ah ah |
| 20:27:39 CAM-1 | ten hours |
| 20:27:42 CAM-2 | yeah but we'll we'll go over eight - no we won't |
| 20:27:44 CAM-1 | not to there we won't |
| CAM-2 | no not really-- |

INTRA-COCKPIT

-20-

TIME &
SOURCE

CONTENT

20:27:48
CAM-1 well-- thirty south southwest of OK City where *

20:27:54
CAM-3 we got the plane full-- what are we waitin' on
now weight tab

CAM-1 have no idea

CAM-2 yeah weight tab for one

CAM-4 what are we waiting for

20:28:14
CAM-3 , who knows- what are we waiting for

CAM-? somebody bring the weather down *

20:28:18
CAM-1 why don't you tell them we're ready to go

20:28:29
CAM-2 over

AIR-GROUND COMMUNICATIONS

TIME &
SOURCE

CONTENT

20:28:23
RDO-2 Ah ramp-- two fifty five at delta
fifteen ah we're ready to go

20:28:32
RAMP two fifty five stand-by

Appendix C

INTRA-COCKPIT

| <u>TIME & SOURCE</u> | <u>CONTENT</u> |
|--------------------------|--|
| CAM-2 | okay |
| CAM-3 | do you want to say something to our happy passengers or should I |
| CAM-3 | I'm gunna say something |
| CAM-2 | Okay |
| CAM-1 | were just were just waitin' for some bags |
| 20:29:10 CAM-2 | brakes |
| CAM-1 | ** have you got one of these |
| CAM-2 | yeah |
| 20:29:18 CAM-1 | lets do the checklist |
| CAM-2 | brakes |
| CAM-1 | set |

-21-

AIR-GROUND COMMUNICATIONS

| <u>TIME & SOURCE</u> | <u>CONTENT</u> |
|--------------------------|---|
| 20:28:53 RAMP | two fifty five push to the circle ground is point eight there |
| 20:28:57 RDO-2 | okay we're cleared to push |

97

INTRA-COCKPIT

-22-

AIR-GROUND COMMUNICATIONS

Appendix C

| <u>TIME & SOURCE</u> | <u>CONTENT</u> |
|--------------------------|--|
| 20:29:21 CAM-2 | windshield heat is on boost pumps we got six on ah cabin pressure controller checked |
| 20:29:26 CAM-2 | aux hydraulic pumps and pressure on and checked |
| 20:29:28 CAM-2 | circuit brakers are ah -- |
| 20:29:30 CAM-1 | checked |
| 20:29:31 CAM-2 | auto-land is checked radios altimeters and flight director *** |
| 20:29:34 CAM-2 | * two nine eight two on the meters |
| CAM-2 | * make it eighty three |
| 20:29:39 CAM-5 | well here's everything you need here and I'm ready to shut the door if you are |
| CAM-1 | okay good bye |
| CAM-5 | bye bye |

INTRA-COCKPIT

TIME & SOURCE CONTENT

20:29:44
CAM-2 and ah --fuel and oil

20:29:49
CAM-2 thirty six- thirty two two required

CAM-1 yeah *

20:29:54
CAM-2 sift through some new weather

CAM-1 * not now

20:29:59
CAM-1 I'm weathered out

20:30:02
CAM-2 one forty four four --*

CAM ((sound similiar to parking brake being released))

20:30:12
CAM-1 we're cleared to go

CAM-2 yup

-23-

AIR-GROUND COMMUNICATIONS

TIME & SOURCE CONTENT

20:30:05
INT-7 hellow cockpit

20:30:08
INT-1 okay you're down there ah

INTRA-COCKPIT

TIME &
SOURCE

CONTENT

-24-

AIR-GROUND COMMUNICATIONS

TIME &
SOURCE

CONTENT

Appendix C

100

CAM ((sound of two cabin chimes))

20:30:27
CAM ((sound of four beeps of the stabilizer trim
in motion horn))

20:30:43
CAM-1 that's it

CAM-2 yup

20:31:08
CAM-2 one * ah here's one--that the flap retract speed
is the same for eleven degrees

CAM-1 oh yeah

20:31:15
CAM-2 forty two--(sixty/fifty) three

INT-1 brakes off lights out push away

20:30:15
INT-7 okay I've got to wait for my tail
walkers ah I don't know where they went
they should be out

20:30:22
RDO-1 seven fifty five needs wing walkers or
we're not going to make orange county

20:30:25
RAMP wing walkers we'll get somebody out
there

INTRA-COCKPIT

AIR-GROUND COMMUNICATIONS

-25-

| <u>TIME & SOURCE</u> | <u>CONTENT</u> |
|--------------------------|---|
| CAM-1 | I'm gunna skip * short approach (fifty three) and ah |
| 20:31:25 CAM-4 | do you have the air conditioning on |
| CAM-2 | it's on it's as cold as it will go |
| 20:31:28 CAM-4 | really |
| 20:31:29 CAM-2 | yup |
| 20:31:31 CAM-2 | no I wouldn't lie to you-- ((sound of laugh)) |
| 20:31:37 CAM-2 | you're gettin' max air right now- until we get some engines running |

| | |
|-------------------|--|
| 20:31:49 INT-1 | okay when your ready let' er rip |
| 20:31:52 INT-7 | yeah there ah gettin' the chocks out now are the brakes off |
| 20:31:55 INT-1 | brakes are off lights out push |

101

Appendix C

INTRA-COCKPIT

-26-

AIR-GROUND COMMUNICATIONS

Appendix C

| <u>TIME & SOURCE</u> | <u>CONTENT</u> |
|--------------------------|--|
| 20:32:04 CAM-1 | # its startin' to rain |
| CAM-2 | * well maybe they'll make it |
| 20:32:45 CAM-2 | ignition seatbelt sign beacon |
| 20:32:52 CAM-2 | there all on |
| 20:32:54 CAM-2 | the before start checklist is complete |
| 20:32:57 CAM-1 | on on - on |

| <u>TIME & SOURCE</u> | <u>CONTENT</u> |
|--------------------------|---|
| 20:32:07 INT-1 | you're really gunna get dumped on in a minute |
| 20:32:09 INT-7 | yeah I know I had that open air tug-- and I decided to switch ah I figured just about time your ready to push is when were gunna get the rain |
| 20:32:17 INT-1 | yeah |
| 20:32:30 INT-7 | somebody jammed them chocks under there pretty good |

102

INTRA-COCKPIT

TIME &
SOURCE

CONTENT

-27-

AIR-GROUND COMMUNICATIONS

TIME &
SOURCE

CONTENT

20:33:29
CAM-1 he didn't say what runway did he

CAM-2 no

20:33:33
CAM ((sound of power interruption to the cvr))

20:33:39
CAM-1 we haven't seen a Pan Am seven forty seven for
so long they don't fly in and out of the west
coast anymore with those they run A three hundreds down
to South America out of there

20:33:48
CAM-2 is that right

CAM-1 yeah

20:33:56
CAM-2 most of the ones they had out on the west coast
were the stubby long range jobs

CAM ((start of cabin passenger briefing by male
flight attendant))

20:33:02
INT-1 okay to start

20:33:04
INT-7 yeah you're clear to start go ahead

INTRA-COCKPIT

TIME &
SOURCE

CONTENT

-28-

CAM-1 yeah--most of them were they had---

20:34:08
CAM-2 annunciator

CAM-1 checked

20:34:09
CAM-2 ignition is off- electrical power is checked
 --apu air is off--air conditioning supply
 switches are auto--cross feeds you got one closed
 --transfer pump and hydraulic systems are on and *--

AIR-GROUND COMMUNICATIONS

TIME &
SOURCE

CONTENT

Appendix C

20:34:20
INT-7 okay brakes set

20:34:25
INT-1 brakes are set

20:34:38
RDO-2 ground northwest seven ah northwest two
 fifty five number one spot ah five

20:34:40
INT-7 okay towbar is disconnected have a nice
 night and we'll wave you off on the
 left

20:34:42
GND northwest two fifty five metro ground
 rcger-- ah what gate did you come out of

104

INTRA-COCKPITTIME &
SOURCECONTENT

-29-

AIR-GROUND COMMUNICATIONSTIME &
SOURCECONTENT

20:35:18

((start of ATIS hotel on the first officer's radio channel))

20:35:19

CAM

((end of cabin briefing))

20:35:35

CAM

((no information recorded for 0.35 seconds due to the passage of the factory tape splice))

CAM-?

20:35:38

CAM-1

* did we get a head count

20:34:46

INT-1 see you later

20:34:48

RDC-2 we came out of delta fifteen

20:34:50

GND okay northwest two fifty five you're in spot four taxi via the ramp hold short of delta expect runway three center hotel is current do you have it

20:34:57

RDC-2 yeah we ah got the info and ah were at spot four we'll hold short of delta on the ramp

20:35:01

GND affirm

105

Appendix C

INTRA-COCKPIT

TIME &
SOURCE

CONTENT

20:35:42
CAM-2

hundred and forty three--*

CAM-2

charlie for three center right

20:35:55

CAM-2

I'm off one I'm gunna get the new ATIS

CAM-1

okay

20:35:59

CAM-1

ah Bruce

20:36:02

CAM-3

yes sir

20:36:04

CAM-1

head count full

CAM-3

head count full-- every jump seat full

-30-

AIR-GROUND COMMUNICATIONS

TIME &
SOURCE

CONTENT

20:35:43

GND

northwest two fifty five continue taxi
now exit at charlie runway three center
contact ground one one niner point four
five

20:35:48

RDO-2

okay ah to charlie for three center
northwest two fifty five

Appendix C

106

INTRA-COCKPIT

TIME &
SOURCE

CONTENT

-32-

AIR-GROUND COMMUNICATIONS

TIME &
SOURCE

CONTENT

ATIS Detroit Metro information hotel two three five zero zulu two thousand five hundred scattered four thousand five hundred scattered estimated ceiling one five thousand broken two five thousand broken visibility six haze temperature eight eight dew point six eight wind three zero zero at one seven altimeter two niner eight four ILS approaches are in use to runways three left and three right departing runways threes notice to airman runway niner two seven is closed taxi way golf is closed south of taxi way hotel taxi way hotel is closed between taxi ways foxtrot and golf taxi way hall is closed taxi way lights on foxtrot between taxiway juliet and runway niner two seven is out of service low level wind shear advisories are in effect birds have been reported within the airport boundaries convective sigmet eight echo is valid until zero zero five five zulu contact detroit flight service for more information advise on initial contact that you have information hotel

20:36:29
CAM-3

* John Wayne

20:36:37
CAM-?

vee speeds--* okay

107

Appendix C

INTRA-COCKPIT

TIME &
SOURCE

CONTENT

20:36:08
CAM-1 except that one

CAM-3 except that one-- we got five--

CAM-1 do you want to ride up there

CAM-1 you got somebody with ya

20:36:13
CAM-3 ya we do--I got somebody sittin' up here

CAM-1 huh

20:36:16
CAM-3 I have somebody sitting up here-- naw takeoffs
 are boring I like landings though maybe at
 Santa Ana if we don't have anybody

CAM-1 whatever

20:36:26
CAM-3 okay

-31-

AIR-GROUND COMMUNICATIONS

TIME &
SOURCE

CONTENT

Appendix C

INTRA-COCKPIT

-33-

AIR-GROUND COMMUNICATIONS

| <u>TIME & SOURCE</u> | <u>CONTENT</u> |
|--------------------------|--|
| 20:36:40 CAM-1 | trim setting |
| 20:36:45 CAM-1 | forty four four how can we be that light for a full airplane |
| CAM-? | ** |
| 20:37:08 CAM-1 | were okay for that center runway aren't we-- |
| 20:37:12 CAM-2 | I'll ah-- |
| CAM-2 | I'll check |
| 20:37:16 CAM-1 | MGL only shows the left or the right one |
| 20:37:21 CAM-2 | I'm sure we are-- |
| 20:37:30 CAM-2 | where's charlie at * |
| 20:37:33 CAM-1 | huh -- |
| 20:37:34 CAM-2 | where- |

| <u>TIME & SOURCE</u> | <u>CONTENT</u> |
|--------------------------|----------------|
|--------------------------|----------------|

INTRA-COCKPIT

| <u>TIME & SOURCE</u> | <u>CONTENT</u> |
|--------------------------|-------------------------------|
| 20:37:35 CAM-1 | right at the end of this ramp |
| 20:37:39 CAM-2 | oh yeah |
| 20:37:41 CAM-1 | no that's bravo |
| 20:37:42 CAM-2 | I think charlie was-- |
| CAM-1 | no it is charlie-- |
| 20:37:44 CAM-2 | sure |
| 20:37:45 CAM-1 | I think so |
| 20:37:47 CAM-1 | did he say three center |
| 20:37:49 CAM-2 | three center yeah |
| 20:37:51 CAM-1 | three center |

-34-

AIR-GROUND COMMUNICATIONS

| <u>TIME & SOURCE</u> | <u>CONTENT</u> |
|--------------------------|----------------|
|--------------------------|----------------|

Appendix C

INTRA-COCKPITAIR-GROUND COMMUNICATIONS

-35-

TIME &
SOURCECONTENT

20:37:52

CAM-2

three center yeah that's why I was thinkin' we had
to go that way

20:37:53

CAM-1

yeah

CAM-1

#

20:37:56

((end of ATIS reception))

20:37:57

CAM-1

- I was thinkin' two one-- I mean

20:38:01

RDO-2

ah ground northwest two fifty five I
guess we went by charlie we're going to
three center right

20:38:03

GND

northwest two fifty five ground
affirmative make a right turn on hotel a
left turn at ah foxtrot and follow the
heavy jet and contact ground on one
nineteen forty five

20:38:10

RDO-2

okay well follow that heavy nineteen
forty five so long

20:38:14

GND

so long

111

Appendix C

INTRA-COCKPIT

TIME & SOURCE

CONTENT

-36-

20:38:16

CAM-1

I just you know ah we landed two one--both times--yeah

20:38:18

CAM-2

they just changed changed runways

20:38:46

CAM-1

tell her we got it

AIR-GROUND COMMUNICATIONS

TIME & SOURCE

CONTENT

Appendix C

GND

Continental six fifty six sorry about the aircraft that taxied behind ya he wasn't follow' in our instructions I couldn't get get a hold of him

656

ah six fifty six no problem

20:38:31

GND

northwest two fifty five are you on the frequency

20:38:34

RDO-2

yeah we are nobody turned us over until just now when I called him back

20:38:40

GND

northwest two fifty five roger taxi to runway three center via taxi way foxtrot and juliet information hotel is now current windshear alerts are in effect and the altimeter is two niner eight five

112

INTRA-COCKPIT

TIME &
SOURCE

CONTENT

-37-

20:38:51
CAM-1 and we're followin' him

20:39:20
CAM-? *

CAM-1 eighty eight

CAM-2 sounds right

CAM-2 yeah we're good

20:39:35
CAM-1 yeah -- more than enough

AIR-GROUND COMMUNICATIONS

TIME &
SOURCE

CONTENT

20:38:52
RDO-2 okay ah we got hotel and ah are we just
suppose to ah change over from twenty
one eight to nineteen forty five on our
own or do they turn us over

20:38:57
GND he said that he switched you over sir I
don't know ah he the controller said
that he switched you over --maybe
another aircraft acknowledged

20:39:04
RDO-2 well we didn't acknowledge

113

Appendix C

INTRA-COCKPIT

TIME &
SOURCE

CONTENT

-38-

CAM-2 forty five one is the --(limit/number)

20:39:38
CAM-1 is it really-- interesting

20:39:44
CAM-2 forty five one that's for ninety degrees I guess
you could interpolate it probably be about --*

20:39:47
CAM-2 it's eighty eight

20:39:48
CAM-1 yeah

CAM ((background unintelligible conversation between
flight attendants)

((Flight changed from Ground control to tower
control frequency at 20:40:37))

AIR-GROUND COMMUNICATIONS

TIME &
SOURCE

CONTENT

20:40:38
TWR Clipper five sixty three for in-trail
separation follow a continental
approaching from your left you need ten
miles in-trail between you and that
northwest DC nine

20:40:39
563 Five sixty three ---

Appendix C

INTRA-COCKPIT

TIME &
SOURCE

CONTENT

-39-

20:41:03
CAM-2 blue streak

CAM-1 yeah

20:41:06
CAM-2 that's Piedmont ah -- or Express

CAM-1 Piedmont Express

20:41:16
CAM-1 isn't that an embrair

20:41:21
CAM-1 no a ah Gulfstream

CAM-2 yeah

AIR-GROUND COMMUNICATIONS

TIME &
SOURCE

CONTENT

20:40:57
TWR Bluestreak fifty sixty four runway three
center the wind's three zero zero at one
four turn right heading zero eight zero
cleared for takeoff

20:41:06
5064 Zero eight zero cleared for takeoff
bluestreak fifty sixty four

21:41:14
TWR Northwest seven sixty six metro tower
wind three zero zero at fourteen runway
three left cleared to land traffic is on
a four mile final

115

Appendix C

INTRA-COCKPIT

-40-

AIR-GROUND COMMUNICATIONS

Appendix C

116

| <u>TIME & SOURCE</u> | <u>CONTENT</u> |
|--------------------------|--|
| 20:41:24 CAM-1 | Gulfstream thirty one |
| 20:41:26 CAM-2 | no it's not a Gulfstream |
| CAM-1 | isn't it |
| 20:41:31 CAM-2 | that's one of those ah -- same same thing Republic Express--Republic Express has |
| 20:41:33 CAM-1 | they get that they got-- |
| 20:41:34 CAM-2 | they're BAE jetstreams they call them |
| 20:41:36 CAM-1 | yeah same thing |
| CAM-2 | yeah |
| 20:41:39 CAM-1 | same thing- same airplane |

20:41:38
TWR Northwest seven sixty six my mistake sir I thought you were ah further out than what you are you are number one for three left the traffic you're following is on the ground

INTRA-COCKPIT

TIME &
SOURCE

CONTENT

20:41:41
CAM-2

BAE makes it

20:41:42
CAM-1

yeah but it used to be a ah -- um

20:41:50
CAM-1

yeah a British company but it's all under
British Aircraft now--had those use to have those
little bitty engines about this big around
little turbo prop noisy

-41-

AIR-GROUND COMMUNICATIONS

TIME &
SOURCE

CONTENT

20:41:46

TWR

Northwest seven fifty two turn right
heading zero six zero three center
cleared for takeoff

20:41:51

752

Right to zero six zero were cleared to
roll on the center northwest seven sixty
two

20:41:54

TWR

Bluestreak fifty sixty four contact
departure control good day

20:41:58

5064

Good day sir

117

Appendix C

INTRA-COCKPIT

TIME &
SOURCE

CONTENT

-42-

20:42:21
CAM-1

if we need to pull up in this taxi way we
will- and back around and take our turn

AIR-GROUND COMMUNICATIONS

TIME &
SOURCE

CONTENT

Appendix C

20:42:00

TWR Northwest two eighty eight turn right
next intersection contact ground one two
one point eight

20:42:08

RDO-2 northwest two fifty five's ready on the
center

20:42:11

TWR northwest two fifty five metro tower
roger I need you to make a ah disregard
northwest two fifty five runway three
center taxi into position and hold
you'll have about three minutes on the
runway you have a in trail separation
behind traffic just departing

20:42:22

RDO-2 okay position and hold northwest ah two
fifty five

20:42:26

TWR Simmons twenty seven ninety six metro
tower winds three zero zero at one three
traffic is a DC nine a mile final runway
three left you're cleared to land

118

INTRA-COCKPIT

AIR-GROUND COMMUNICATIONS

-43-

TIME &
SOURCE

CONTENT

TIME &
SOURCE

CONTENT

20:42:31

CAM-1

no not holding up for that # Continental ten

20:42:36

PA-2

ah ladies and gentlemen ah we're currently number one for departure -- should be rolling in a couple minutes ah we got ah two minutes in trail separation ---flight attendants please be seated thank you

20:42:44

TWR

Northwest one eighty five metro tower if you're with me plan to make a right turn in the run-up pad

20:42:49

185

Okay one eighty five ah we'll go in the run-up pad

20:42:51

TWR

One eighty five thank you you gotta one five mile in-trail restriction behind company on the runway and he has the same restriction behind the aircraft that just departed

20:42:55

CAM

((sounds similar to cockpit door being closed))

119

Appendix C

INTRA-COCKPIT

TIME &
SOURCE

CONTENT

-44-

20:42:57
CAM-1 it's blacker than # out there

20:43:00
CAM-2 a little rain out there

20:43:04
CAM-2 transponder is set and on

20:43:06
CAM-2 annunciator

20:43:09
CAM-1 checked

20:43:11
CAM-2 and ignition

CAM ((sound of click))

20:43:12
CAM-1 on

AIR-GROUND COMMUNICATIONS

TIME &
SOURCE

CONTENT

20:42:59
185 Okay one eighty five

20:43:02
TWR Northwest seven fifty two contact
departure thanks for all your help this
evening

20:43:04
752 Seven fifty two good night sir

Appendix C

120

INTRA-COCKPIT

TIME &
SOURCE

CONTENT

20:43:18
CAM ((sound of click))

20:43:38
CAM-1 well we ain't goin' left

20:43:40
CAM-2 nope

20:43:42
CAM-1 that's for sure

-45-

AIR-GROUND COMMUNICATIONS

TIME &
SOURCE

CONTENT

20:43:20
TWR Simmons twenty seven ninety six long
landing approved if you like

20:43:30
TWR Northwest one eighty five you can plan
to follow a continental seven thirty
seven or correction one eighty five
disregard that taxi up to and hold short
of the runway I'll be able to get you
out that jet behind you also has a delay

20:43:39
185 Okay one eighty five we'll ah hold short
of the runway

20:43:45
594CC Citation five ninety four charlie
charlie with you on the approach for
three right

121

Appendix C

INTRA-COCKPIT

TIME &
SOURCE

CONTENT

-46-

AIR-GROUND COMMUNICATIONS

TIME &
SOURCE

CONTENT

Appendix C

20:43:48

TWR Citation five ninety four charlie
charlie metro tower winds three zero
zero at thirteen runway three right
cleared to land where are you parking on
the field

20:43:55

594CC Three zero zero at one three and we'll
be going to page avjet

20:43:59

TWR Northwest seven sixty six contact ground
one two one point eight

20:44:04

TWR northwest two fifty five runway three
center turn right heading zero six zero
cleared for takeoff

20:44:08

RDO-2 right to zero six zero cleared to go
northwest two fifty five

20:44:12

TWR Northwest one eighty five metro tower
three center taxi into position and hold
you have about three minutes two to
three minutes on the runway

122

INTRA-COCKPIT

AIR-GROUND COMMUNICATIONS

-47-

TIME &
SOURCE

CONTENT

TIME &
SOURCE

CONTENT

0:44:14.8
AM ((sound similar to parking brake released))

0:44:21
AM ((sound of increasing engine power))

0:44:28
AM-1 won't stay on

0:44:29.1
AM ((sound of click))

0:44:30
AM-2 won't go on

0:44:31
AM-1 but they won't stay on-

0:44:32
AM-2 okay power's normal

20:44:17
185 Okay position and hold northwest one
eighty five

20:44:38
TWR Northwest fourteen sixty six metro tower
traffic your following is a very short
final runway three left cleared to land
winds three zero zero at one three

123

Appendix C

INTRA-COCKPIT

TIME &
SOURCE

CONTENT

20:44:38.8

CAM

((sound of click))

20:44:39

CAM-1

TCI was un-set

20:44:39.8

CAM

((sound of click))

20:44:42

CAM-2

can you get'em now- there you go

20:44:43

CAM-2

there on now - clamp

20:44:45.6

CAM-2

hundred knots

20:44:46.2

CAM-1

okay

20:44:55

CAM-1

((sound of laugh))

20:44:57.1

CAM-2

vee one

-48-

AIR-GROUND COMMUNICATIONS

TIME &
SOURCE

CONTENT

20:44:51

TWR

Northwest fourteen sixty six so far
that's approved i'll advise different

Appendix C

124

INTRA-COCKPIT

TIME & SOURCE CONTENT

20:44:57.7
CAM-2 rotate

20:44:59.1
CAM ((sound similar to nose gear strut extension))

20:45:02.7
CAM ((sound similar to nose wheel spinning down))

20:45:05.1
CAM ((sound of stick shaker starts and continues until the end of tape))

20:45:09.1
CAM ((sound of secondary stall recognition aural warning starts))

20:45:11.4
CAM ((sound of secondary stall recognition aural warning starts))

20:45:11.9
CAM-? (* right up to the vee bar)

20:45:14.3
CAM ((sound of secondary stall recognition aural warning starts))

20:45:15.7
CAM-? (ah) #

-49-

AIR-GROUND COMMUNICATIONS

TIME & SOURCE CONTENT

125

Appendix C

INTRA-COCKPIT

TIME &
SOURCE

CONTENT

-50-

20:45:17.1
CAM ((sound of secondary stall recognition aural
warning starts))

20:45:19.3
CAM ((sound of first impact))

20:45:19.7
CAM ((sound of second impact))

20:45:22.7
CAM ((sound of third impact))

CAM-? *

20:45:23.1
CAM ((sound of fourth impact))

20:45:24.2
CAM ((sound of fifth impact))

20:45:24.4
CAM ((sound of sixth impact))

20:45:24.6
CAM ((sound of seventh impact))

20:45:24.7 ((end of recording))

AIR-GROUND COMMUNICATIONS

TIME &
SOURCE

CONTENT

Appendix C

20:45:18
102UM Metro tower lifeguard copter one zero
two uniform mike is ah

126

APPENDIX D

VISUAL DISPLAYS OF FLIGHT 255
FROM PUSHBACK TO INITIAL IMPACT

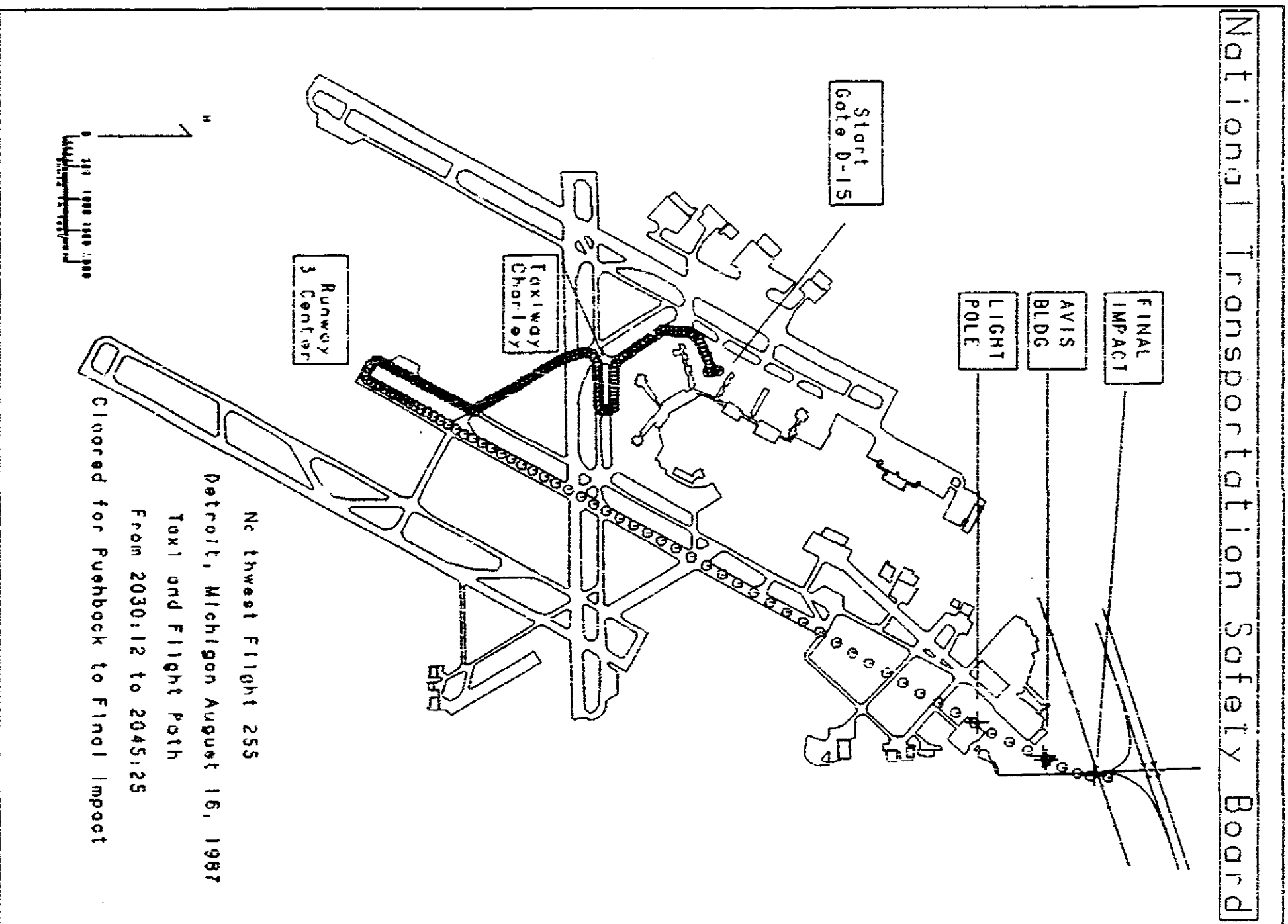

National Transportation Safety Board

2030:12 (CAM-1) we're cleared to go
 (CAM-2) yup
 (INT-1) brakes off lights out push away
 2030:15 (INT-7) okay I've got to wait for my tail walkers ah I
 don't know where they went they should be out
 (CAM) ((sound of two cabin ahnee))
 2030:22 (RDO-1) seven fifty five needs wing walkers or
 we're not going to make orange county
 2030:25 (RAMP) wing walkers we'll get somebody out there
 2030:27 (CAM) ((sound of four beeps of the stabilizer trim
 in motion horn))
 2030:43 (CAM-1) that's it
 (CAM-2) yup
 2031:08 (CAM-2) one e ah here's one--that the
 flap retract speed is the same for eleven degree
 (CAM-1) oh yeah
 2031:15 (CAM-2) forty two--(sixty/fifty)three
 (CAM-1) I'm gonna skip e short approach (fifty three) oh ah
 2031:25 (CAM-4) do you have the air conditioning on
 (CAM-2) it's on it's as cold as it will go
 2031:28 (CAM-4) recily
 2031:29 (CAM-2) yup
 2031:31 (CAM-2) no I wouldn't lie to you--((sound of laugh))
 2031:37 (CAM-2) you're gettin' max air right now
 - until we get some engines running
 2031:49 (INT-1) okay when you're ready let 'er rip
 2031:52 (INT-7) yeah they're ah gettin' the checks out now
 are the brakes off
 2031:55 (INT-1) brakes are off lights out push
 2032:04 (CAM-1) e its startin' to rain

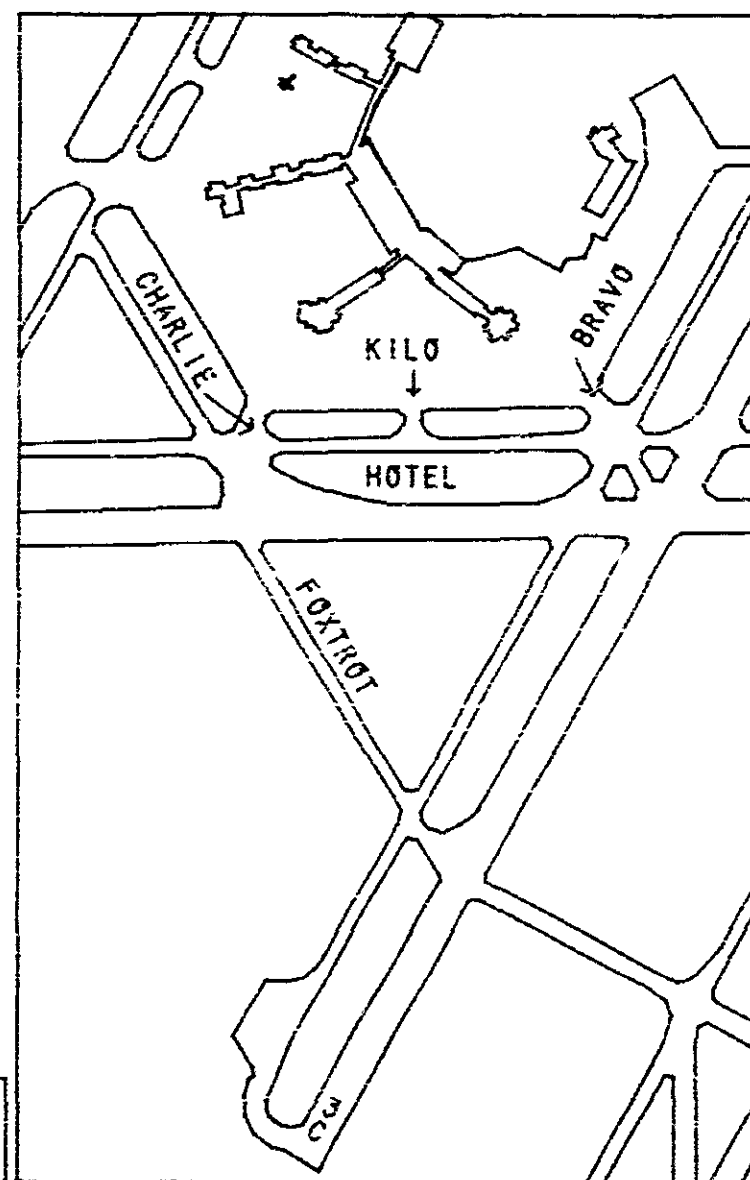

N
 One airplane symbol shown for each transcript time
 Airplane not to scale
 0 500 1000 1500 2000
 Scale in feet

TIME PERIOD
 2230:11 - 2232:05

National Transportation Safety Board

2032:07 (INT-1) you're really gonna get dumped on in a minute
 2032:09 (INT-7) yeah I know I had that open air tug--and I decided
 to switch ah I figured just about time you're
 ready to push it when were gonna get the rain
 2032:17 (INT-1) yeah
 (CAM-2) e well maybe they'll make it
 2032:30 (INT-7) somebody jammed them checks under there
 pretty good
 2032:46 (CAM-2) ignition seatbelt sign beccen
 2032:52 (CAM-2) they're all on
 2032:54 (CAM-2) the before start checklist is complete
 2032:57 (CAM-1) on on - on
 2033:02 (INT-1) okay to start
 2033:04 (INT-7) yeah you're clear to start go ahead
 2033:29 (CAM-1) he didn't say what runway did he
 (CAM-2) no
 2033:33 (CAM) ((sound of power interruption to the cvr))
 2033:39 (CAM-1) we haven't seen a Pan Am seven forty seven for
 so long they don't fly in and out of the west
 coast anymore with those they run A three
 hundreds down to South America out of there
 2033:48 (CAM-2) is that right
 (CAM-1) yeah
 2033:55 (CAM-2) most of the ones they had out on the west coast
 were the stubby long range jobs
 (CAM) ((start of cabin passenger briefing
 by male flight attendant))
 (CAM-1) yeah--most of them were they had--
 2034:08 (CAM-2) annunciator
 (CAM-1) checked
 2034:09 (CAM-2) ignition is off--electrical power is checked--
 opu air is off--air conditioning supply switches
 are auto --cross feeds you got one closed--
 transfer pump and hydraulic systems are on and e--

N

One airplane symbol shown for each transcript time

Airplane not to scale

0 500 1000 1500 2000
 Scale in feet

TIME PERIOD
 2232:06 - 2234:10

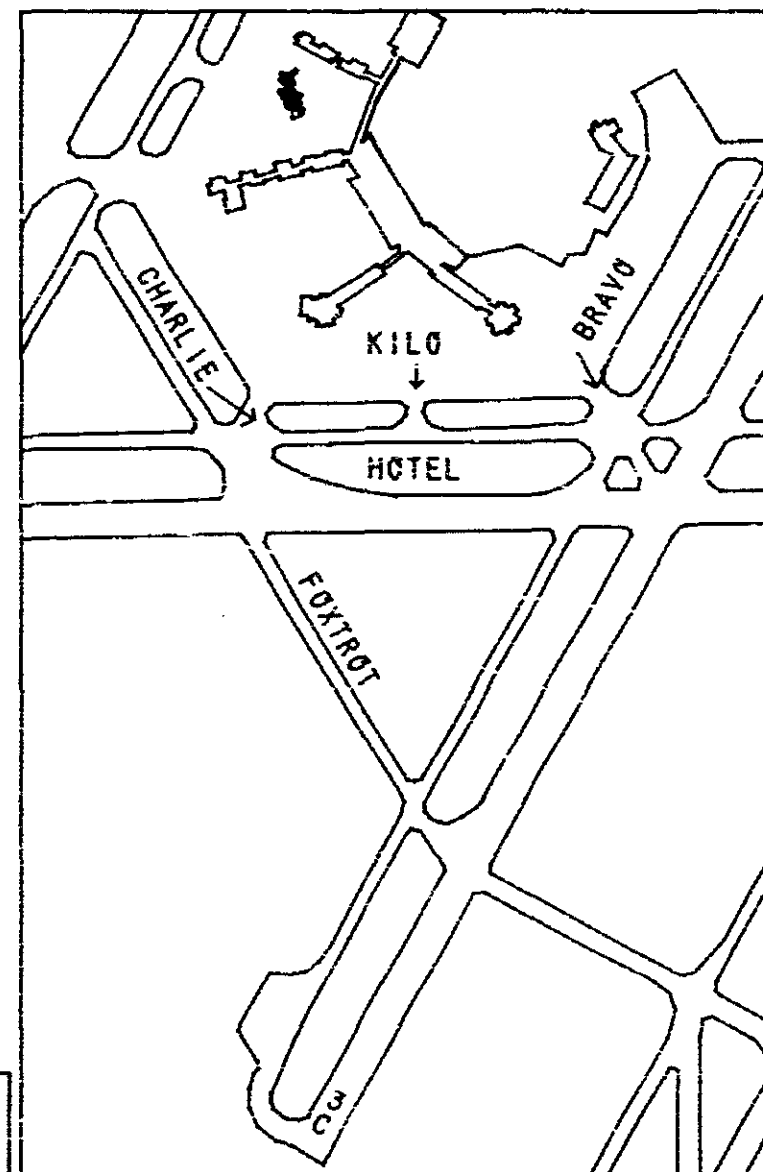

National Transportation Safety Board

2034:20 (INT-7) okay brakes set
 2034:23 (INT-1) brakes are set
 2034:33 (RDO-2) ground northwest seven oh northwest
 two fifty five number one spot oh five
 2034:40 (INT-7) okay towbar is disconnected have a nice night
 and we'll wave you off on the left
 2034:42 (GND) northwest two fifty five metro ground roger--
 oh what gate did you come out of
 2034:46 (INT-1) see you later
 2034:48 (RDO-2) we came out of delta fifteen
 2034:50 (GND) okay northwest two fifty five you're in spot four
 taxi via the ramp hold short of delta expect runway
 three center hotel is current do you have it
 2034:57 (RDO-2) yeah we oh got the info and oh were at spot four
 we'll hold short of delta on the ramp
 2035:01 (GND) affirm
 2035:18 ((start of ATIS hotel on the first officer's
 radio channel))
 2035:19 (CAM) ((end of cabin briefing))
 2035:35 (CAM) ((no information recorded for 0.35 seconds
 due to the passage of the factory tape splice))
 (CAM-7) see
 2035:38 (CAM-1) e did we get a head count
 2035:42 (CAM-2) hundred and forty three--e
 2035:43 (GND) northwest two fifty five continue taxi now
 exit at charlie runway three center contact
 ground one one niner point four five
 2035:48 (RDO-2) stay oh to charlie for three center
 northwest two fifty five
 (CAM-2) charlie for three center right

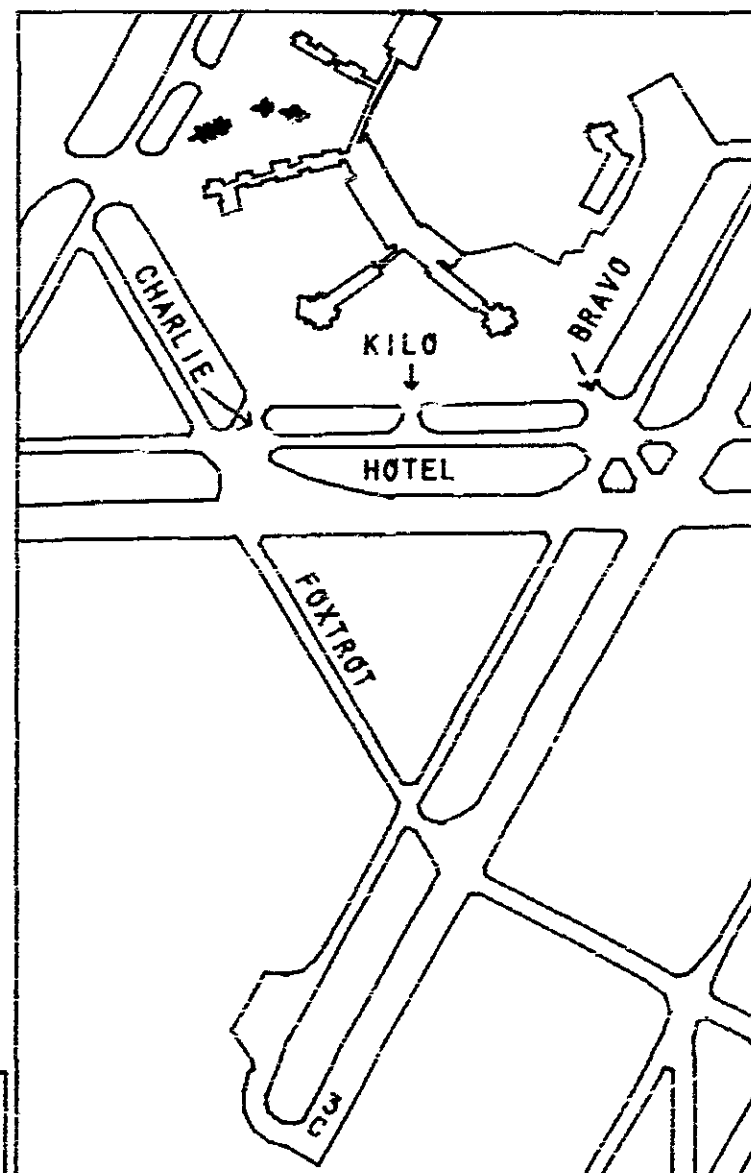

N
 One airplane symbol shown for each transcript time
 Airplane not to scale
 0 500 1000 1500 2000
 Scale in feet

TIME PERIOD
 2234:11 - 2235:49

National Transportation Safety Board

2035:55 (CAM-2) I'm off one I'm gonna get the new ATIS
 (CAM-1) okay
 2035:59 (CAM-1) oh Bruce
 2036:02 (CAM-3) yee air
 2036:04 (CAM-1) head count full
 (CAM-3) head count full--every jump seat full
 2036:08 (CAM-1) except that one
 (CAM-3) except that one--we got five--
 (CAM-1) do you want to ride up there
 (CAM-1) you got somebody with ya
 2036:13 (CAM-3) ya we do--I got somebody sittin' up here
 (CAM-1) huh
 2036:16 (CAM-3) I have somebody sitting up here--new takeoffs
 are boring I like landings though maybe at
 Santa Ana if we don't have anybody.
 (CAM-1) whatever
 2036:26 (CAM-3) okay
 2036:29 (CAM-3) o John Wayne
 2036:37 (CAM-7) vee speeds--s okay
 2036:40 (CAM-1) trim setting
 2036:45 (CAM-1) forty four four how can we be that light
 for a full airplane
 (CAM-7) ss
 2037:08 (CAM-1) we're okay for that center runway aren't we--
 2037:12 (CAM-2) I'll oh--
 (CAM-2) I'll check
 2037:16 (CAM-1) MGL only shows the left or the right one
 2037:21 (CAM-2) I'm sure we are--

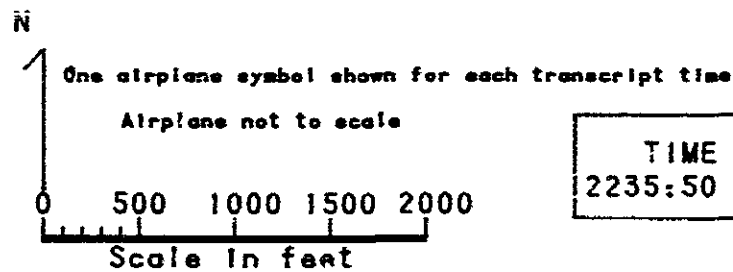
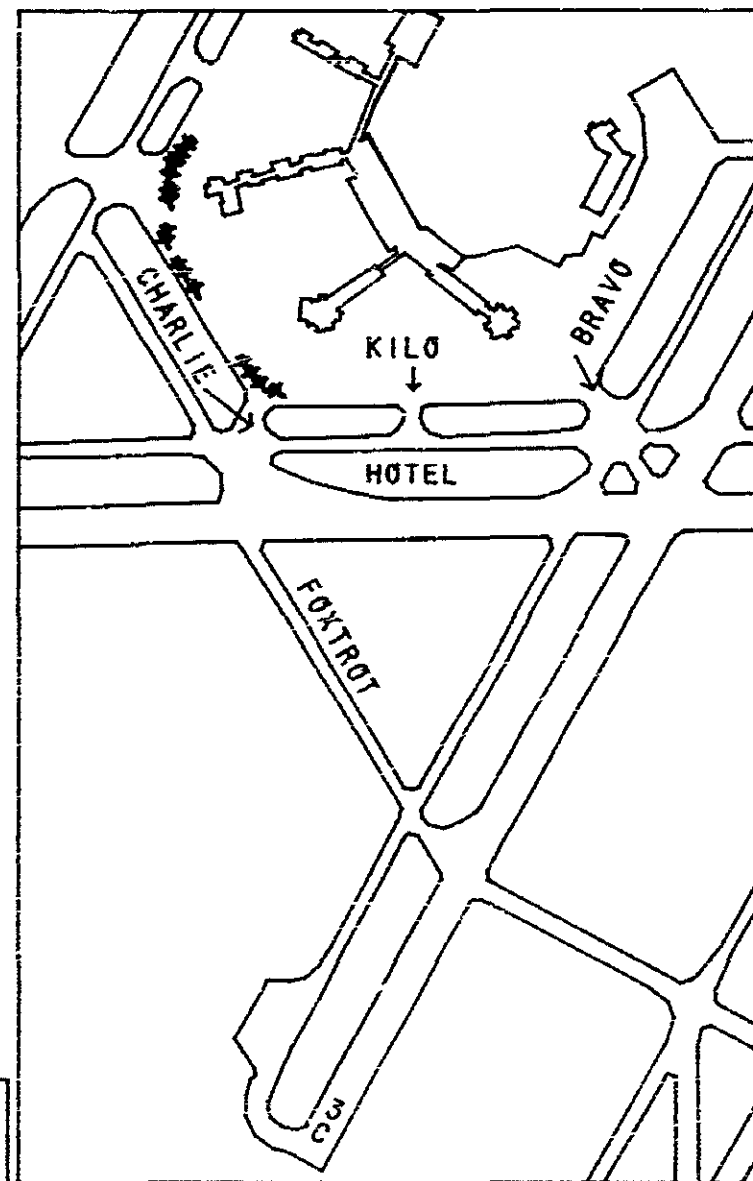

TIME PERIOD
 2235:50 - 2237:22

National Transportation Safety Board

2037:30 (CAM-2) where's charlie at s
 2037:33 (CAM-1) huh--
 2037:34 (CAM-2) where--
 2037:35 (CAM-1) right at the end of this ramp
 2037:39 (CAM-2) oh yeah
 2037:41 (CAM-1) no that's bravo
 2037:42 (CAM-2) i think charlie wa--
 (CAM-1) no it is charlie--
 2037:44 (CAM-2) sure
 2037:45 (CAM-1) i think so
 2037:47 (CAM-1) did he say three center
 2037:49 (CAM-2) three center yeah
 2037:51 (CAM-1) three center
 2037:52 (CAM-2) three center yeah that's why i was thinkin'
 we had to go that way
 2037:53 (CAM-1) yeah
 (CAM-1) s
 2037:56 ((end of ATIS reception))
 2037:57 (CAM-1) i was thinkin' two one--i seen
 2038:01 (RDE-1) ah ground northwest two fifty five i guess we
 went by charlie we're going to three center right
 2038:03 (GND) northwest two fifty five ground affirmative make a
 right turn at hotel a left turn at ah foxtrot and
 follow the heavy jet and contact ground
 on one nineteen forty five
 2038:10 (RDE-2) okay well follow that heavy nineteen forty five
 so long
 2038:14 (GND) so long
 2038:16 (CAM-1) i just you know ah we landed two one
 --both times--yeah
 2038:18 (CAM-2) they just changed changed runways

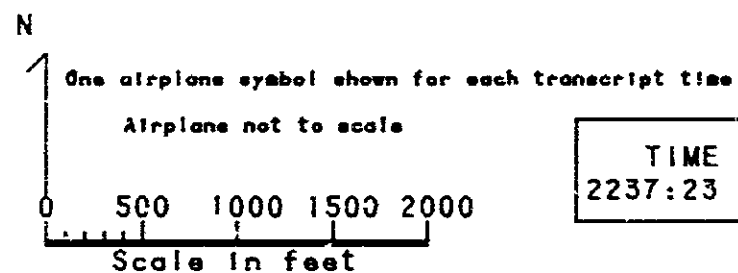

TIME PERIOD
2237:23 - 2238:20

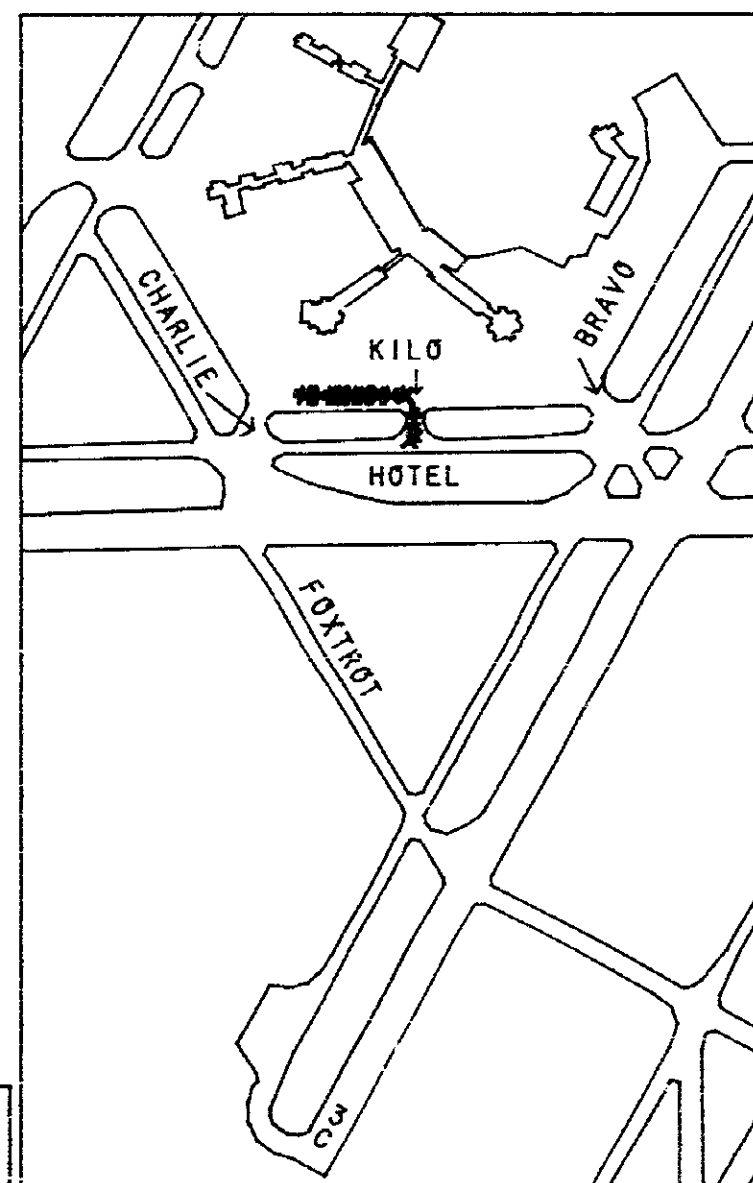

National Transportation Safety Board

2038:51 (GND) northwest two fifty five are you on the frequency
 2038:54 (RDO-2) yeah we are nobody turned us over until just now
 when I called him back
 2038:40 (GND) northwest two fifty five roger taxi to runway three
 center via taxi way foxrot and Juliet information
 hotel is now current windhear alerts are in effect
 and the altimeter is two nine- eight five
 2038:46 (CAM-1) tall her we got it
 2038:51 (CAM-1) and we're followin' him
 2038:52 (RDO-2) okay ah we got hotel and ah are we just suppose
 to ah change over from twenty one eight to nine-
 teen forty five on our own or do they turn us over
 2038:57 (GND) he said that he switched you over sir I don't
 know ah he the controller said that he switched
 you over--maybe another aircraft acknowledged
 2039:04 (RDO-2) well we didn't acknowledge
 2039:20 (CAM-7) e
 (CAM-1) eighty eight
 (CAM-2) sounds right
 (CAM-2) yeah we're good
 2039:35 (CAM-1) yeah--more than enough
 (CAM-2) forty five one is the --(limit/number)
 2039:38 (CAM-1) is it really--interesting
 2039:44 (CAM-2) forty five one that's for ninety degree I guess
 you could interpolate it probably be about--e

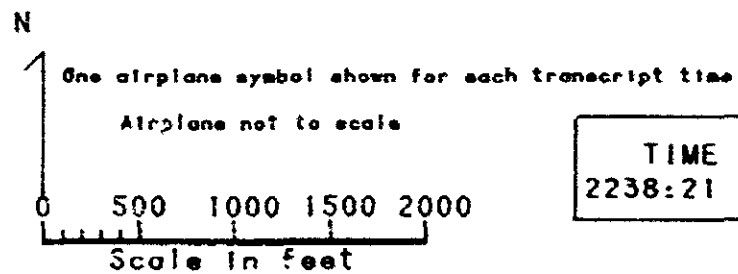
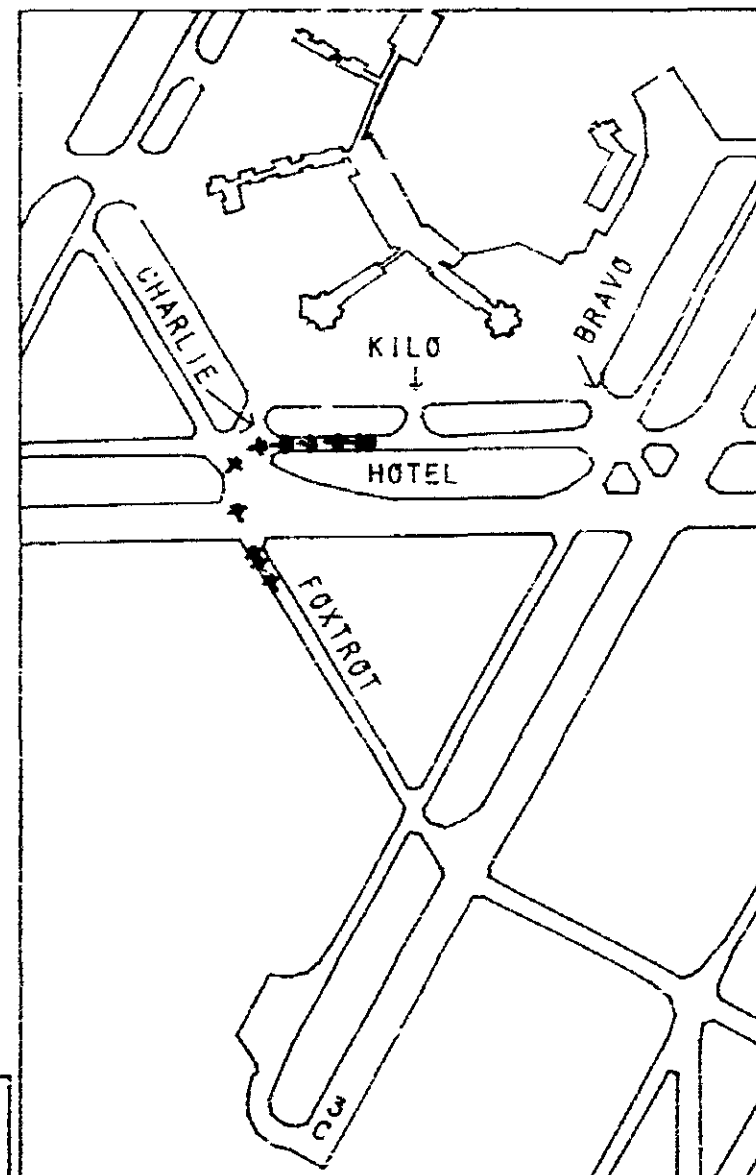

TIME PERIOD
 2238:21 - 2239:45

National Transportation Safety Board

2039:47 (CAM-2) it's eighty eight
 2039:48 (CAM-1) yeah
 2039:49 (CAM) ((background unintelligible conversation
 between flight attendants))
 ((Flight changed from Ground control to tower
 control frequency at 2040:37))

2041:03 (CAM-2) blue streak
 (CAM-1) yeah
 2041:06 (CAM-2) what's Piedmont oh -- or Express
 (CAM-1) Piedmont Express
 2041:16 (CAM-1) isn't that an Embraer
 2041:21 (CAM-1) no o ah Gulfstream
 (CAM-2) yeah
 2041:24 (CAM-1) Gulfstream thirty one
 2041:26 (CAM-2) no it's not a Gulfstream
 (CAM-1) isn't it
 2041:31 (CAM-2) that's one of those oh -- some some thing
 Republic Express -- Republic Express has
 2041:33 (CAM-1) they got that they got--
 2041:34 (CAM-2) they're BAE jetstreams they call them
 2041:36 (CAM-1) yeah some thing
 (CAM-2) yeah
 2041:39 (CAM-1) some thing - some airplane
 2041:41 (CAM-2) BAE makes it
 2041:42 (CAM-1) yeah but it used to be a oh -- um
 2041:50 (CAM-1) yeah a British company but it's all under British
 Aircraft now--had these use to have these little
 bitty engines about this big around little turbo
 prop noisy

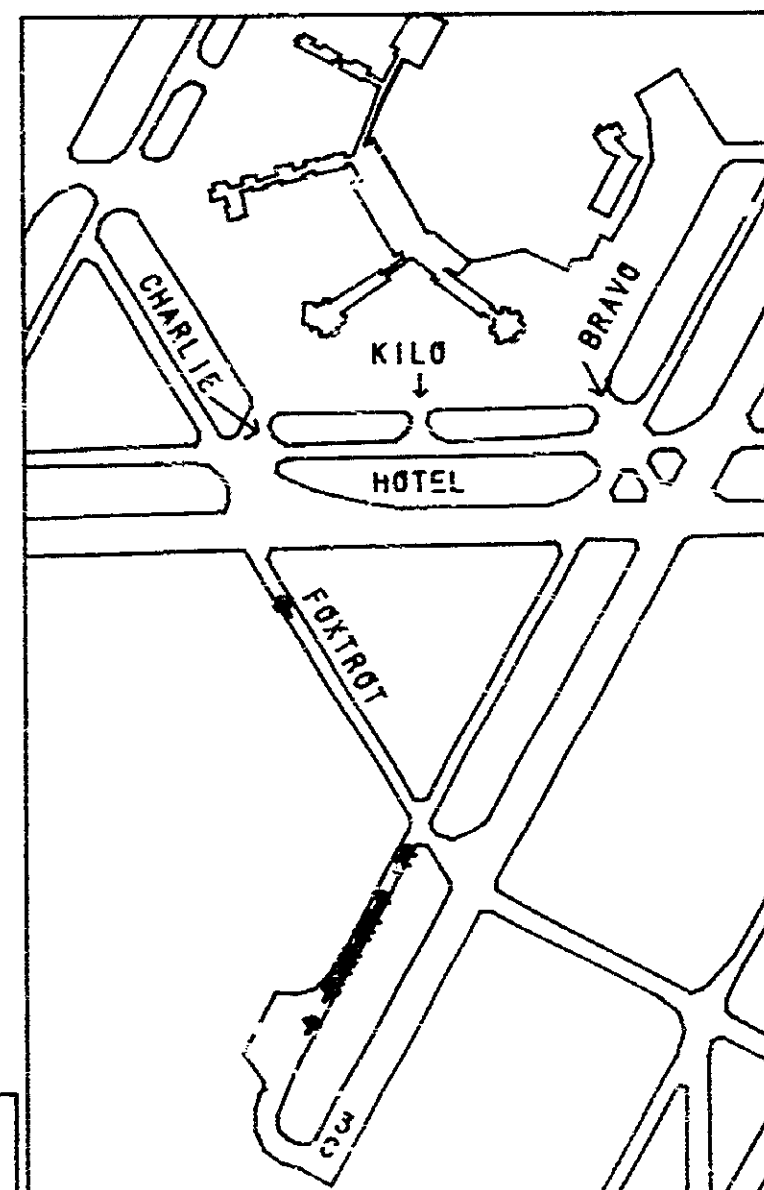

N
 See airplane symbol shown for each transcript time
 Airplane not to scale

0 500 1000 1500 2000
 Scale in feet

TIME PERIOD
 2239:46 - 2241:51

National Transportation Safety Board

2042:08 (RDG-2) northwest two fifty five's ready at the center
 2042:11 (TWR) northwest two fifty five centre tower Roger I need you to make a ah disregard northwest two fifty five runway three center taxi into position and hold you'll have about three minutes on the runway you have a in trail separation behind traffic just departing
 2042:21 (CAM-1) if we need to pull up in this taxi way we will -and back around and take our turn
 2042:22 (RDG-2) okay position and hold northwest oh two fifty five
 2042:31 (CAM-1) no not holding up for that # Continental ten
 2042:36 (PA-2) ah ladies and gentlemen ah we're currently number one for departure — should be rolling in a couple minutes ah we got ah two minutes in trail separation — flight attendants please be seated thank you
 2042:55 (CAM) ((sounds similar to cockpit door being closed))
 2042:57 (CAM-1) it's blacker than # out here
 2043:00 (CAM-2) a little rain out there
 2043:04 (CAM-2) transponder is set and on
 2043:06 (CAM-2) annunciator
 2043:09 (CAM-1) checked
 2043:11 (CAM-2) and ignition
 (CAM) ((sound of click))
 2043:12 (CAM-1) on
 2043:18 (CAM) ((sound of click))
 2043:38 (CAM-1) well we ain't gain' left
 2043:40 (CAM-2) nope
 2043:42 (CAM-1) that's for sure

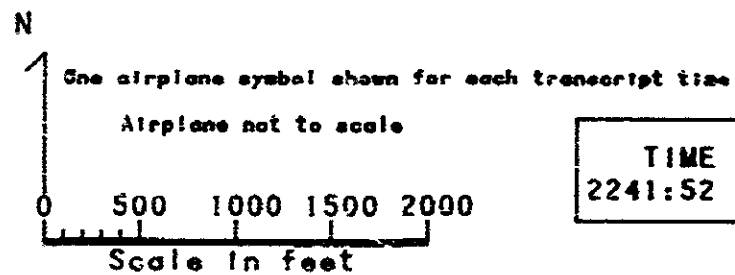
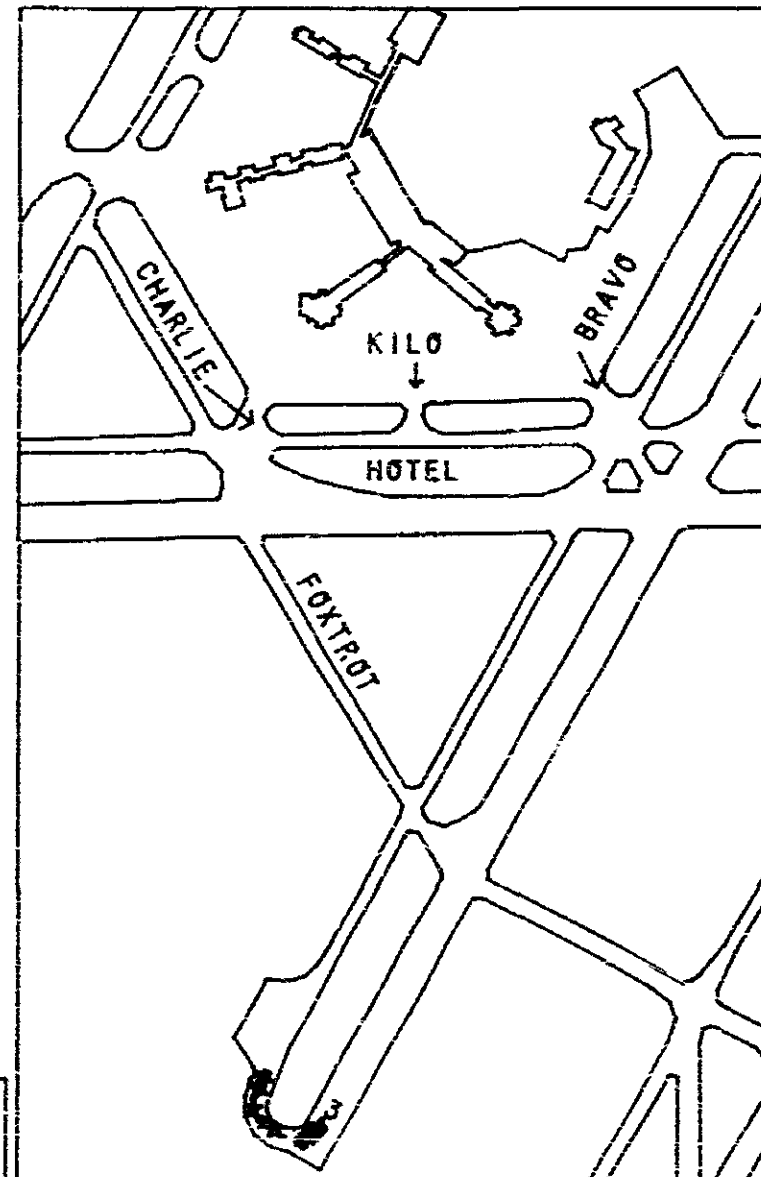

TIME PERIOD
 2241:52 - 2243:43

National Transportation Safety Board

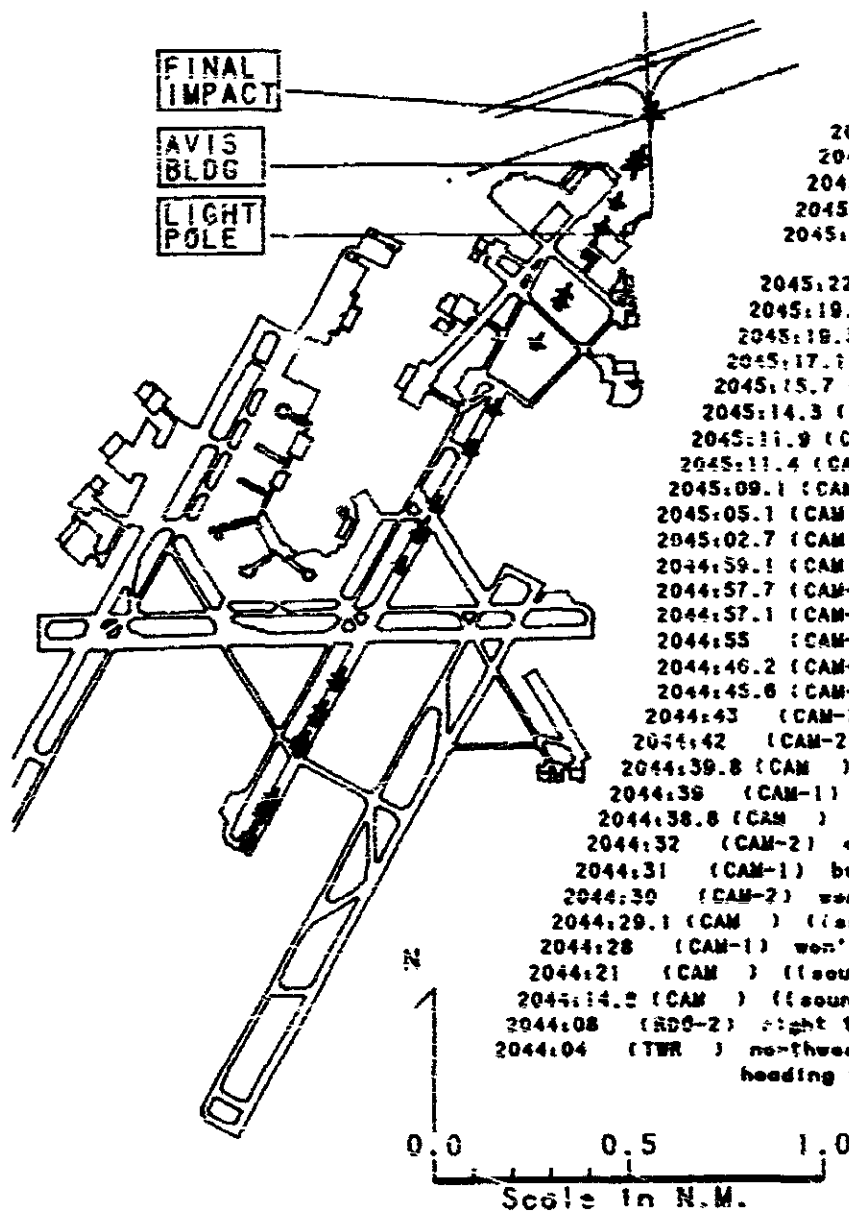

One airplane symbol shown for each transcript time
Airplane not to scale

2045:24.7 (CAM) ((end of recording))
 2045:24.6 (CAM) ((sound of seventh impact))
 2045:24.4 (CAM) ((sound of sixth impact))
 2045:24.2 (CAM) ((sound of fifth impact))
 2045:23.1 (CAM) ((sound of fourth impact))
 (CAM-7) *
 2045:22.7 (CAM) ((sound of third impact))
 2045:19.7 (CAM) ((sound of second impact))
 2045:19.3 (CAM) ((sound of first impact))
 2045:17.1 (CAM) ((sound of secondary stall recognition aural warning starts))
 2045:15.7 (CAM-7) (sh) *
 2045:14.3 (CAM) ((sound of secondary stall recognition aural warning starts))
 2045:11.9 (CAM-7) (s right up to the vee bar)
 2045:11.4 (CAM) ((sound of secondary stall recognition aural warning starts))
 2045:09.1 (CAM) ((sound of secondary stall recognition aural warning starts))
 2045:05.1 (CAM) ((sound of stick shaker starts and continues until the end of tape))
 2045:02.7 (CAM) ((sound similar to nose wheel spinning down))
 2044:59.1 (CAM) ((sound similar to nose gear strut extension))
 2044:57.7 (CAM-2) rotate
 2044:57.1 (CAM-2) vee one
 2044:55 (CAM-1) * ((sound of laugh))
 2044:46.2 (CAM-1) okay
 2044:45.6 (CAM-2) hundred knots
 2044:43 (CAM-2) they're on now - clamp
 2044:42 (CAM-2) can you get'em now - there you go
 2044:39.8 (CAM-2) ((sound of click))
 2044:39 (CAM-1) TCI was un-set
 2044:38.8 (CAM) ((sound of click))
 2044:32 (CAM-2) okay power's normal
 2044:31 (CAM-1) but they won't stay on-
 2044:30 (CAM-2) won't go on
 2044:29.1 (CAM) ((sound of click))
 2044:28 (CAM-1) won't stay on
 2044:21 (CAM) ((sound of increasing engine power))
 2044:14.2 (CAM) ((sound similar to parking brake released))
 2044:08 (RDO-2) right to zero six zero cleared to go northwest two fifty five
 2044:04 (TWR) northwest two fifty five runway three center turn right
 heading zero six zero cleared for takeoff

TIME PERIOD
2243:44 - 2245:25

NORTHWEST
MD-80

EXTERNAL ELECTRIC & PNEUMATIC SOURCE - START

PNEUMATIC X-FEEDS BOTH CLOSED
 PNEUMATIC AIR SOURCE CONNECTED & ON
 PNEUMATIC X-FEEDS OPEN
 PNEUMATIC PRESSURE (25 PSI MIN) CKD
 COMPLETE - BEFORE START CHECKLIST

AFTER ENGINES STABILIZED

PNEUMATIC X-FEEDS BOTH CLOSED
 ELECTRIC POWER *CKD
 EXTERNAL ELECTRIC & PNEUMATIC DISCONNECTED
 COMPLETE - AFTER START CHECKLIST

BEFORE START

BRAKES SET
 WINDSHIELD HEAT *ON
 FUEL PUMPS *(AS REQ)
 CABIN PRESSURE CONTROLLER *SET
 AUX HYDRAULIC PUMP & PRESSURE *ON & CKD
 CIRCUIT BREAKERS *CKD
 AUTOLAND CKD
 RADIOS, ALTIMETERS & FLIGHT DIR *CKD & SET
 FUEL & OIL *(QUANTITIES) & RESET

IGNITION ON
 SEAT BELT SIGN ON
 BEACON OFF

AFTER START

ANNUNCIATOR CKD
 IGNITION *OFF
 ELECTRIC POWER *CKD
 APU AIR *(AS REQ)
 AIR CONDITIONING SUPPLY SWITCHES *AUTO
 PNEUMATIC X-FEEDS *ONE CLOSED
 TRANSFER PUMP & HYDRAULIC SYSTEMS *ON & CKD

TAKE

FLAPS *(SETTING)
 TRIM *(SETTING)
 EPR & AIRSPEED DIALS *(SETTINGS)
 ARTS (AS REQ)
 FLIGHT INSTRUMENTS *(MDC) & SLAVING
 CONTROLS & ELEVATOR POWER *CKD-TOP
 *CKD-BOTTOM

DELAYED ENGINE START

BRAKES & IGNITION (AS REQ) & ON
 DELAYED AFTER START

ANNUNCIATOR CKD
 IGNITION *OFF
 ELECTRIC POWER *CKD
 APU AIR *OFF
 AIR CONDITIONING SUPPLY SWITCHES *AUTO

ENGINE ANTI-ICE & FUEL HEAT (AS REQ)
 PNEUMATIC X-FEEDS *CLOSED
 APU *(AS REQ)

BEFORE TAKEOFF

FLIGHT ATTENDANT *NOTIFIED
 TRANSPONDER *ON
 ANNUNCIATOR CKD
 IGNITION ON

CLIMB

NO SMOKE SIGN *(AS REQ)
 IGNITION *(AS REQ)
 FUEL PUMPS *(AS REQ)
 CABIN PRESSURE CONTROLLER *CKD
 SYNC *ON
 HYDRAULIC PUMPS *OFF & LOW
 FLAP TAKEOFF SELECTOR *STORED

IN-RANGE

ALTIMETERS *(SETTING) & X-CKD
 EPR *(GA)
 AIRSPEED DIAL *(SETTING)
 SEAT BELT SIGN *ON
 CABIN PRESSURE CONTROLLER *CKD
 HYDRAULIC PUMPS *ON & HIGH

BEFORE LANDING

NO SMOKE SIGN *ON
 IGNITION *ON
 FUEL SYSTEM *SET FOR LANDING
 SYNC *OFF
 GEAR *THREE GREEN
 SPOILERS *ARMED
 AUTO BRAKES (AS REQ)

FLAPS *(SETTING)*

AFTER LANDING

SPOILERS *DOWN
 FLAPS *(AS REQ)
 ICE PROTECTION *OFF
 IGNITION *OFF
 APU *(AS REQ)
 PNEUMATIC X-FEED *ONE OPEN
 RADAR & TRANSPONDER *OFF & STANDBY
 APU AIR & ELECTRIC POWER *(AS REQ) & CKD

PARKING

AIR CONDITIONING SUPPLY SWITCHES *OFF & AUTO
 PNEUMATIC X-FEEDS *OPEN
 FUEL CONTROLS OFF
 SEAT BELT SIGN OFF
 BEACON *OFF
 CHOCKS & BRAKES (AS REQ)
 AUX & TRANSFER PUMPS *OFF
 FUEL PUMPS *(AS REQ)
 WINDSHIELD HEAT *(AS REQ)
 LOGBOOK ENTRY (AS REQ)

TERMINATING

EMERGENCY LIGHTS *OFF
 PITOT HEAT *OFF
 AIR CONDITIONING PANEL *(AS REQ)
 RADIOS & GALLEY POWER *OFF

SECURING AIRPLANE AT MG: WMA STATIONS

APU *OFF
 OUTFLOW CONTROL *(AS REQ)
 BATTERY SWITCH *OFF

APPENDIX E

DC-9-82 CHECKLIST

DOUGLAS MD-80

RECEIVING AIRPLANE CHECKLIST

LOGBOOKS CKD
 CIRCUIT BREAKERS CKD
 VOICE RECORDER CKD
 GENERATORS ON
 GROUND PROX WARNING CKD
 MAX SPEED WARNING CKD
 MACH TRIM NORMAL
 YAW DAMPER ON
 STALL WARNING CKD
 ANTI-SKID CKD & ARMED
 APU PANEL CKD
 GALLEY POWER ON
 AC & DC BUS X-TIES AUTO & OPEN
 EMERGENCY POWER CKD & OFF
 AIR CONDITIONING PANEL CKD

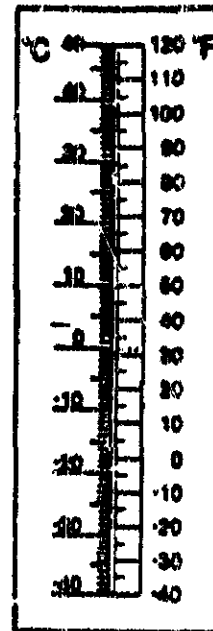

AIR CONDITIONING AUTO SHUTOFF AUTO
 RAM AIR OFF
 FUEL PUMPS CKD
 IGNITION OFF
 START PUMP OFF
 EMERGENCY CABIN LIGHTS CKD & ARMED
 NO SMOKE SIGN ON
 PITOT-STATIC HEAT CKD & CAPT
 AIRFOIL ANTI-ICE OFF
 WINDSHIELD HEAT CKD
 ENGINE ANTI-ICE CKD & OFF
 WARNING & CAUTION LIGHTS CKD
 EXTERIOR LIGHTS CKD
 DFCS CKD
 AUTO THROTTLES OFF
 AUTOPILOT OFF
 GEAR LEVER & LIGHTS DOWN & CKD
 AUX, TRANSFER & ENGINE PUMPS CKD
 HYDRAULIC QUANTITY & PRESSURE CKD
 FIRE CONTROLS CKD

APU START
 OUTFLOW CONTROL *AUTO
 BATTERY SWITCH *ON
 APU PANEL *CKD
 FIRE WARNING *CKD
 AIR CONDITIONING SUPPLY SWITCHES *OFF
 START PUMP *(AS REQ)
 AUX HYDRAULIC PUMP *OFF
 MASTER SWITCH *START/ARM
 OIL PRESS LOW LIGHT *OFF BY 35%
 APU AIR & ELECTRIC POWER *ON & CKD
 FUEL PUMP *ONE RIGHT ON
 START PUMP *OFF

BRAKE PRESSURE CKD
 PARKING BRAKE (AS REQ)
 STATIC SELECTORS **NORMAL
 ALTIMETERS & CLOCKS ***(SETTINGS)
 RADIOS & FLIGHT INSTRUMENTS **CKD
 BRAKE TEMPS *CKD
 STANDBY HORIZON CKD
 TCI CKD
 FUEL & OIL CKD & RESET
 RADAR & TRANSPONDER OFF & STANDBY
 STABILIZER TRIM CKD
 SPOILERS CKD
 RUDDER CONTROL POWER
 FUEL X-FEED OFF
 OUTFLOW CONTROL CKD & AUTO
 FUEL CONTROLS OFF
 TRIM TABS FREE & SET
 PNEUMATIC X-FEEDS OPEN
 AUTO BRAKE OFF
 OXYGEN & MASKS **CKD



FAA Approved
 FORM FO-25
 Rev 3/13/87