

CERN 78-04



CERN 78-04
Proton Synchrotron
Machine Division
7 April 1978

ORGANISATION EUROPÉENNE POUR LA RECHERCHE NUCLÉAIRE
CERN EUROPEAN ORGANIZATION FOR NUCLEAR RESEARCH

THE CONTROL SYSTEM FOR THE CERN PROTON SYNCHROTRON
CONTINUOUS TRANSFER EJECTION

D. Bloess, J. Boucheron, D. Fiander, D. Grier, A. Krusche,
F. Ollenhauer, P. Pearce, H. Riege and G.C. Schneider

GENEVA
1978

© Copyright CERN, Genève, 1978

Propriété littéraire et scientifique réservée pour tous les pays du monde. Ce document ne peut être reproduit ou traduit en tout ou en partie sans l'autorisation écrite du Directeur général du CERN, titulaire du droit d'auteur. Dans les cas appropriés, et s'il s'agit d'utiliser le document à des fins non commerciales, cette autorisation sera volontiers accordée.

Le CERN ne revendique pas la propriété des inventions brevetables et dessins ou modèles susceptibles de dépôt qui pourraient être décrits dans le présent document; ceux-ci peuvent être librement utilisés par les instituts de recherche, les industriels et autres intéressés. Cependant, le CERN se réserve le droit de s'opposer à toute revendication qu'un usager pourrait faire de la propriété scientifique ou industrielle de toute invention et tout dessin ou modèle décrits dans le présent document.

Literary and scientific copyrights reserved in all countries of the world. This report, or any part of it, may not be reprinted or translated without written permission of the copyright holder, the Director-General of CERN. However, permission will be freely granted for appropriate non-commercial use.

If any patentable invention or registrable design is described in the report, CERN makes no claim to property rights in it but offers it for the free use of research institutions, manufacturers and others. CERN, however, may oppose any attempt by a user to claim any proprietary or patent rights in such inventions or designs as may be described in the present document.

CERN 78-04
Proton Synchrotron
Machine Division
7 April 1978

ORGANISATION EUROPÉENNE POUR LA RECHERCHE NUCLÉAIRE
CERN EUROPEAN ORGANIZATION FOR NUCLEAR RESEARCH

THE CONTROL SYSTEM FOR THE CERN PROTON SYNCHROTRON
CONTINUOUS TRANSFER EJECTION

D. Bloess, J. Boucheron, D. Fiander, D. Grier, A. Krusche,
F. Ollenhauer, P. Pearce, H. Riege and G.C. Schneider

GENEVA
1978

ABSTRACT

This report describes the hardware and the software structure of a stand-alone control system for the continuous transfer ejection from the CERN Proton Synchrotron to the Super Proton Synchrotron. The process control system is built around a PDP 11/40 mini-computer interfaced to the ejection elements via CAMAC. It features automatic failure recovery and real-time process optimization. Performance, flexibility, and reliability of the system are evaluated.

CONTENTS

	<u>Page</u>
1. INTRODUCTION	1
2. CONTINUOUS TRANSFER PROCESS	1
3. CONTROL SYSTEM OBJECTIVES	2
4. CONTROL SYSTEM HARDWARE	3
4.1 Equipment layout	3
4.2 Computer hardware	3
4.3 Interface hardware	5
4.4 Main control room console layout	5
4.5 Back-up facilities	6
5. CONTROL SYSTEM SOFTWARE	6
5.1 Design background and over-all software structure	6
5.2 Operating system and CAMAC driver	7
5.3 Equipment drivers and their synchronization	10
5.4 Interpreter language and intermediate control tasks	10
5.5 Communication in the software structure	12
6. FEATURES OF THE SUBSYSTEMS AND THEIR CONTROL SOFTWARE	14
6.1 General remarks	14
6.2 Fast bumper (FB) system	14
6.2.1 <i>General features</i>	14
6.2.2 <i>FB control</i>	16
6.2.3 <i>FB control software</i>	17
6.3 Timing system	18
6.3.1 <i>Timing hardware description</i>	18
6.3.2 <i>Timing software</i>	19
6.4 Auxiliary magnet power supplies (APS)	19
6.4.1 <i>General description</i>	19
6.4.2 <i>APS controls</i>	19
6.4.3 <i>APS software</i>	21
6.5 Beam diagnostics (BD)	21
6.5.1 <i>BD elements and features</i>	21
6.5.2 <i>BD software</i>	23

	<u>Page</u>
6.6 Electrostatic septum (ES)	24
6.6.1 <i>Interactive control program</i>	24
6.6.2 <i>Intermediate control tasks</i>	24
6.7 Links to other PS control systems	25
7. OPERATION OF THE CONTINUOUS TRANSFER EJECTION	25
7.1 Interaction facilities	25
7.2 Specific operational problems	26
7.3 Operation facilities	26
7.4 Closed-loop optimization for extracted beam intensity	27
8. NOVEL CONTROL FEATURES	27
8.1 System diagnostics and automatic error recovery	27
8.2 On-line software development and implementation	29
9. RELIABILITY	29
9.1 Major reliability features	29
9.2 Operational experience	29
10. FUTURE IMPROVEMENTS	30
11. CONCLUSIONS	31
REFERENCES	33

1. INTRODUCTION

Does it pay to introduce computers into accelerator control? Though computers have been "in fashion" for quite some time, only recently have accelerators come into operation controlled fully by computers. The merits of computer controls designed specifically for and together with a new accelerator, such as the CERN SPS, have been clearly demonstrated¹⁾. However, the computerization of the continuous transfer ejection has posed difficult problems, because the process has used, in part, existing manually controlled equipment and has been grafted on to a machine which has been in continuous operation and evolution for more than 15 years.

The simple substitution of computer-aided controls for manual ones would not contribute much to accelerator performance; the performance might even deteriorate. Introducing computer controls is profitable only when they tend to go in the direction of accelerator automation and when they allow the users to execute control functions which would be impossible with a manual system, or which permit these functions to be performed much faster, hence improving considerably the flexibility and availability of the accelerator. The development of control systems featuring such advanced control functions, on the other hand, requires a considerably higher effort than that of manual control systems.

The design of the control system for the continuous transfer ejection started early in 1975. Originally it was foreseen to fit it, as a satellite system, into an integrated PS control system. However, since the continuous transfer of protons to the SPS had to operate in May 1976, a stand-alone control system had to be designed independently from other computer controls in the PS.

From the beginning²⁾ the aim was to produce a control system that offered more benefits than the mere replacing of push buttons by terminal keys or "software buttons". An analysis of the performance of the control system as it has been implemented and the experience gained over one and a half years of operation suggest that this aim has been achieved and encourage an affirmative reply to the initial question.

2. CONTINUOUS TRANSFER PROCESS

The PS injects a proton beam at 10 GeV/c into the SPS. The transfer mode used is called continuous transfer (CT)^{3,4)}. Figure 1 shows a synoptic overview of the transfer system. It uses a fast bump obtained from a pair of kicker magnets FB21, FB9⁵⁾ to shift the beam across the electrostatic septum deflector ES31 in a number of steps each lasting one PS revolution. The strength of the fast bump is adjusted to shave a constant current of protons over the desired number of PS turns. This multiturn shaving ejection allows a uniform filling of the SPS when 10 steps are chosen (SPS circumference = 11 × PS circumference). The injection into the SPS can, in principle, be made over several PS pulses (multipulsing), with 5, 3 or 2 shaving steps, hence increasing the beam intensities by a factor of 2, 3 or 5.

Apart from the modulated fast bump and the electrostatic septum deflector at the heart of the ejection process, an extraction septum magnet (SM16) finally extracts the shaved beam from the PS ring and sends it via the TT2 tunnel to the SPS. Beam gymnastics to prepare the ejection are performed by a number of auxiliary elements. Two pairs of slow bumper dipoles

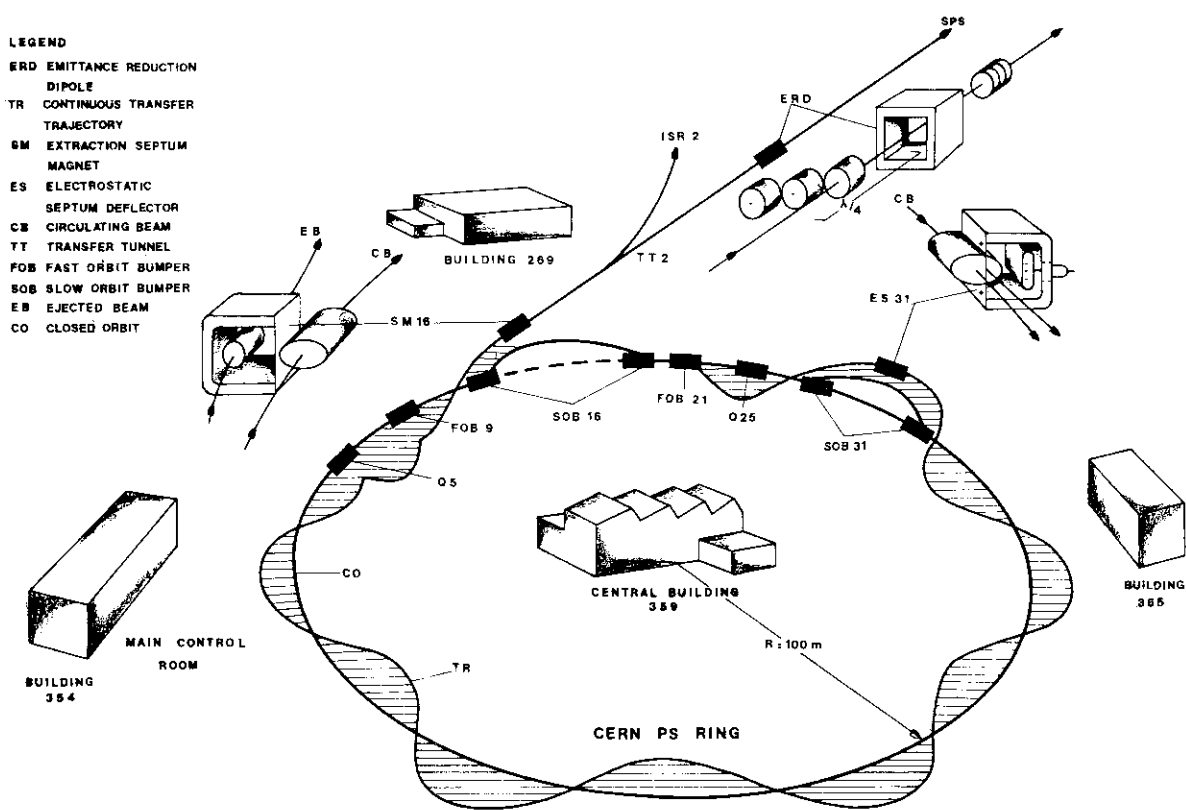

Fig. 1 Synoptic diagram of continuous transfer process

(for bumps SB16 and SB31) allow the beam, prior to ejection, to be placed near the electrostatic septum ES31 and the extraction septum magnet SM16. A pair of quadrupoles (Q25, Q5) produces a local transverse blow-up of the beam, so reducing the beam losses and the momentum compaction factor at septum ES31 position and enhancing the kick of the fast kicker magnets and of the ES31 on the beam.

Several beam diagnostic elements (see also Fig. 14 in Section 6) provide information about the functioning of the ejection and feedback for corrective actions. Beam-current transformers are placed in the PS ring and the transfer tunnel TT2. Monitors close to the septa indicate beam losses during the ejection process, and two sets of toposcopes installed in tunnel TT2 measure the position and the profile of the ejected beam.

A third programmed fast dipole magnet, similar to the main fast bumper magnets, is installed in the tunnel TT2. It acts on slices of the extracted beam to reduce the integral beam emittance to its strict minimum. This emittance reduction dipole (ERD) is pulsed and controlled in a similar way to the main fast bumper magnets.

3. CONTROL SYSTEM OBJECTIVES

The primary function of the control system is to steer the CT process such that the best possible proton beam be made available to the SPS. The control system should enable the correct set-up of the equipment to be rapidly made and easily changed.

The active control has to be supported by comprehensive real-time status, alarm and performance data feedback to the operator. Closed-loop control between extracted beam and CT elements should guarantee high quality of the ejection over long run periods, without frequent operator intervention. Recovery from fault conditions should be fast, preferably automatic, as high availability of equipment and control system is a main objective. Extensive diagnostic and logging facilities should help the equipment engineers to do maintenance.

Accelerator systems are subject to constant evolution. Hence controls in accelerators must be flexible. Control hardware and software need to be modified with the process on line (i.e. during accelerator operation) to avoid long machine shut-down time. The control system had to be designed to support the control of the ejection process, program development, on-line testing and implementation of hardware and software, all in parallel with little mutual interference.

Since it was apparent that a perfect, fault-free control system could not be achieved, the design had to provide for fault tolerance. The rule adopted was that after any serious control system failure the process would continue to run with the last given settings until the relevant back-up could be brought into action. Automatic error detection and correction makes life with an error-prone system acceptable.

A final objective was to develop the control system in a short time. *A priori* it became clear that a working control system could be achieved only if all people involved in the development of the project -- equipment engineers, machine physicists and operators -- were able to contribute actively to control hardware and software. The access, the development facilities and the use of the control system had to be sufficiently simple so that those responsible for a piece of ejection equipment could develop their own test and control software without depending heavily on computer specialists.

4. CONTROL SYSTEM HARDWARE

4.1 Equipment layout

Figure 1 shows that the CT system elements are distributed over the circumference of the PS and in the transfer tunnel TT2. Most of the power supplies, the pulse generators, and the electronic equipment (for fast bumpers, septa, and beam diagnostics) are located in building 359 in the centre of the PS ring. The auxiliary power supplies for the quadrupoles and slow bumpers are installed in building 365 outside the accelerator ring. During PS operation the CT process has to be controlled from the PS Main Control Room (MCR). However, local access in the central building must be guaranteed to engineers responsible for the maintenance and debugging of the CT equipment.

Figure 2 is a block diagram of the main control system hardware, comprising the equipment control interfaces, the computer system proper, the local terminals, the operators' MCR console, and the related links.

4.2 Computer hardware

The main elements of the PDP-11/40 configuration are shown in Fig. 2. Originally only two removable disks were used, which proved unreliable during long-term operation and therefore a double capacity non-removable disk was added. During the development period the

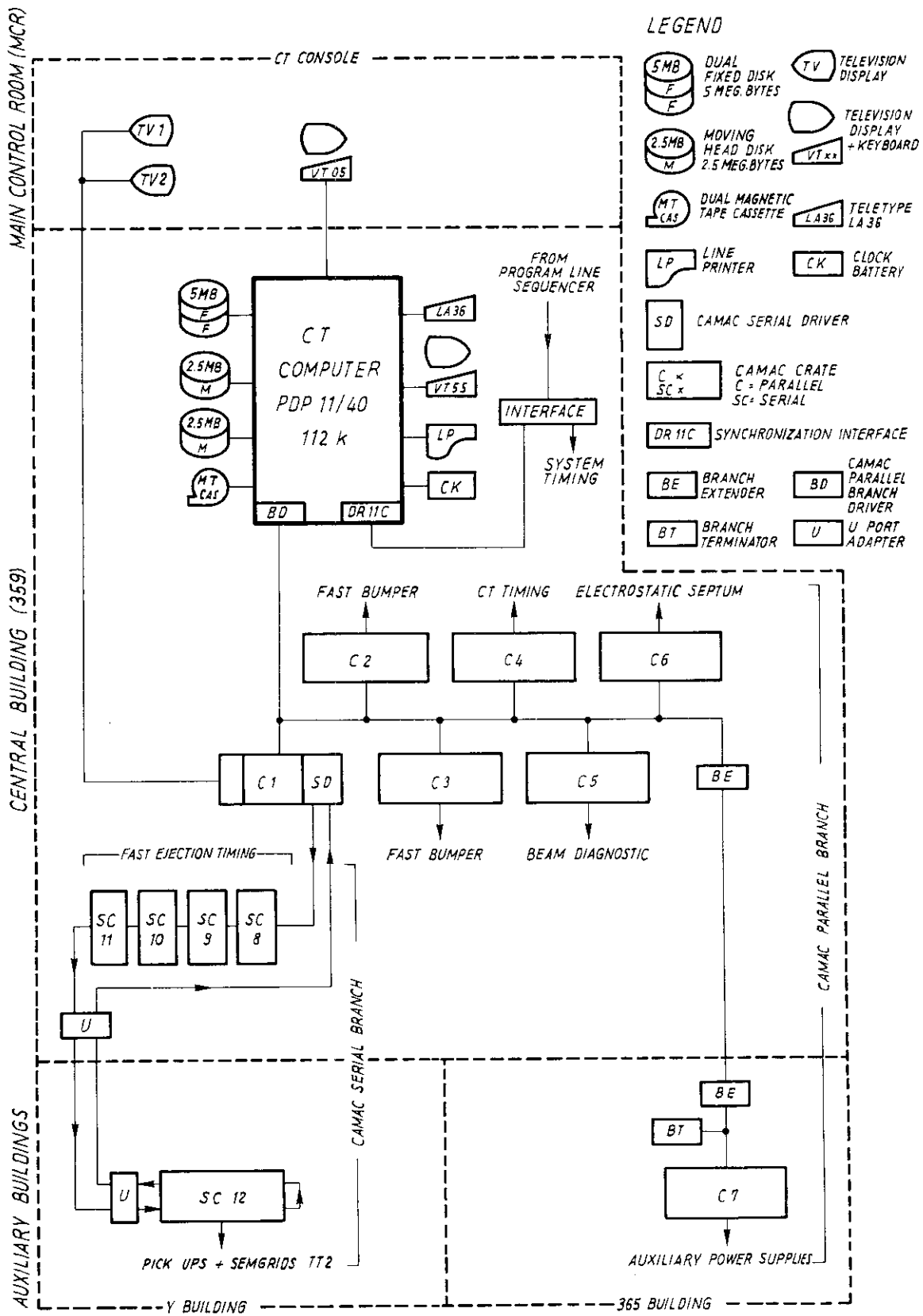

Fig. 2 Continuous transfer control system block diagram

system underwent frequent expansions of processor options (floating-point unit, clocks), and of memory and peripheral hardware. The computer equipment is housed in three racks to reduce heating problems. A battery-powered clock serves as time reference for the control system.

The main interface to the process is established via a CAMAC parallel branch driver (Schlumberger SAIP, type ICP 11-B). Via this interface, data can be transferred in single-word mode and in block mode by direct memory access (DMA). The CT computer is synchronized to the PS program line sequencer (PLS) through a special interface. Information concerning the type of PS magnet cycle, scheduled ejection operations, and programmed beam intensities is entered at the start of each PS cycle into the computer memory by hardware interrupts.

4.3 Interface hardware

The long distances between the CT process elements, as well as the very noisy environment (very high pulse currents and voltages), raise severe problems of reliability. A serial process interface would have been highly desirable under such circumstances. However, at the time when a decision for the interface had to be taken the serial CAMAC system was not yet commercially available. Therefore a parallel CAMAC branch was chosen as main interface to the process. Some problems appeared with the fragile branch cable connectors, the branch extender modules, and the remote branch terminator located in building 365, which can block the branch if not powered. A further drawback of the parallel branch is the limited maximum number (seven) of crates. In order to connect additional crates for new fast ejection timing zones, a serial CAMAC branch loop was introduced into the existing parallel branch. The serial branch driver added to the parallel CAMAC system as a group of modules allows connection of another 62 crates. By connecting a FIFO memory to the serial branch driver the computer can be relieved of synchronization problems with block data transfers, which are autonomously performed by the serial driver. Contrary to the case of the parallel branch, remote crates can be easily bypassed on the serial loop.

One of the adopted rules of control philosophy is to buffer all acquired and transmitted data in the equipment interface. Cycle-to-cycle setting refreshment is not required and equipment can thus continue to run with the latest settings, even following computer or CAMAC interface breakdowns. Throughout the CT system, standardization of CAMAC modules has been adhered to where possible in order to simplify maintenance. Where necessary an intermediate level of interfacing hardware between CAMAC and the CT ejection equipment is formed by special chassis (NIM, etc.). Careful attention was paid to the isolation of modules by transformers or opto-couplers between the special interfaces and CAMAC.

4.4 Main control room console layout

The dialogue between operators and the process passes through a VT05 video terminal (see Fig. 3). In addition, two standard TV monitors present information about the ejected beam and the equipment. The TV monitor 1 is mainly dedicated to the display of the ejected beam intensity sampled either during each PS cycle or in a selected one. TV monitor 2 is linked to the program chosen on the VT05 console. It displays the vital information of the subsystem the operator is acting upon. The display information consists of a static frame with data refreshed every PS cycle. Valuable information is provided by analog oscilloscope displays of ejected-beam intensity and fast-bumper current wave forms.

data will then consume a considerable fraction of the cycle time. On-line diagnostics, automatic recovery from fault situations and closed-loop controls are based on a regular surveillance of the process and the control system. Tasks such as beam statistics, equipment surveillance, optimization procedures and certain time-consuming equipment control functions would block the normal access from the MCR console if they did not run in parallel with the foreground control functions initiated by the operators. The same would be true for on-line program development and on-line testing or implementation of new control software. In an environment where different people are responsible for the development of the different parts of the controls, the corresponding control tasks in the computer must run independently and be fully protected. A final important aspect was the ease of programming, supported by adequate languages and programming facilities. The usual difficulties arose in that commercially available software did not completely fit the needs.

The software structure is the result of a compromise between the different objectives and constraints. The chosen structure favours flexibility, ease of programming and on-line testing, rather than standardization and homogeneity. Closed-loop controls, automatic settings, and automatic fault detection and recovery are possible only when the total ejection and equipment status is known by the control system, together with the desired system reference state. This virtual reference state is built up by the active commands to the equipment issued either from operators or from automatic procedures in the control system itself. The reference state can be compared at any moment with the measured system state; hence the correct behaviour of the system can be checked and corrective actions and relevant messages be initiated. For security reasons a copy of the working reference values contained in the PDP-11/40 memory is stored in the CT data bank on disk. It is a fundamental rule that all working reference data in core and on disk have to correspond to the equipment status at any moment.

Only a real-time multiprogramming system supporting many independent foreground and background activities can fulfil the CT control requirements. This real-time multitasking system has to support the hardware protection features of the minicomputer. For easy recovery from control-system failures a disk-based operating system was chosen. The disk also serves as a secondary storage medium for the CT data bank and all program files.

The large memory capacity of the PDP-11/40 allows running of time critical control software as core-resident tasks. The relatively long disk access time (of the order of 100 ms) precludes the use of only disk-resident control software, especially when the PS cycle time will be further reduced. The distribution of the control functions of each CT subsystem over the different software levels is a major problem. The main decision criteria are the speed of execution required, the frequency of execution, and the ease of implementation. The faster a certain process and the more frequent its execution, the lower is the language level and the higher the need for core residence. All system software, synchronization software, and device and equipment drivers are written in assembler language, whereas most of the intermediate and high-level control tasks are coded in a high-level language.

5.2 Operating system and CAMAC driver

At the outset of the design of the CT control system, two real-time disk-based multitasking operating systems were offered for the PDP-11/40 computer: the system RSX11-D had already been on the market for two years, whereas the first version of the system RSX11-M

had just been released. The choice was made for RSX11-M, though this system was less flexible, offered fewer facilities, and was not fully tested. However RSX11-M seemed better adapted to real-time process control. RSX11-M interrupt and directive handling are considerably faster than in RSX11-D, which features more overhead. Owing to the greater modularity of RSX11-M it can be tailored more easily to a particular application. The memory-resident part of RSX11-M occupies only a quarter of the memory filled by the memory-resident part of RSX11-D. A few modifications were needed to the RSX11-M system to make it compatible with the CT control system requirements. Apart from the implementation of a CAMAC driver, described below, the synchronization of the control software to the PS cycle events required an extension of the asynchronous software interrupt service facility.

The CT control system uses widely a very valuable feature offered by RSX11-M, called the indirect command processor, which can execute complex sequences of commands and tasks in a partly interactive way. Starting-up and shutting down procedures, as well as changing the mode of control system operation, are performed by indirect command files.

The major addition made to the RSX11-M system was the general-purpose CAMAC driver⁶⁾. This device driver handles all data transfers between computer and process equipment via the ICP11-B CAMAC interface peripheral. Following the philosophy of the RSX11-M system any device driver is implemented as a part of the core-resident executive. A device, in the DEC PDP-11 sense, is an interface connected directly to the PDP-11 UNIBUS. The software CAMAC driver has to handle single-word as well as block (DMA) data transfers. Since any input-output (I/O) request via the RSX11-M system implies a 2 ms overhead, the numerous and quite diverse CAMAC transfers to be performed regularly in the CT system have to be initiated by only a few I/O requests. The CAMAC driver is written such that any number of CAMAC transfers of any type can be actuated in sequence via one single I/O request. The CAMAC commands are queued in the form of "cells"⁷⁾ containing information about the type of command (single-word or DMA, CAMAC address and function) and the data storage (see Fig. 4). In addition to the 2 ms cell queue initialization time due to the I/O request, each single-word cell now requires 60 μ s, and each DMA cell about 200 μ s execution time. The over-all time for transmitting approximately 1000 CAMAC commands in one PS cycle becomes about 100 ms including all overhead. For easy retrieval and treatment of the CAMAC data by the process control software their storage and sequential arrangement in the computer memory is independent of the cell positions (Fig. 4). Thus the data can be loaded from the CAMAC registers directly into the task memory area where they are needed. They can immediately be stored in tables in a way which is best suited to the particular subprocess control software.

The speed of the CAMAC driver is sufficient to handle even the serial CAMAC loop added to the parallel CAMAC branch. Each single net CAMAC transfer on the serial loop is built up by a series of six or seven normal CAMAC transfers on the parallel branch. Special macros in the system macro library allow transfers to be handled on the serial loop in the same way as on the parallel branch. Block-data transfers within the serial loop are automatically executed by the serial-hardware branch driver after being initialized from the PDP-11 computer via the parallel CAMAC branch.

The development of device drivers in RSX11-M is very time consuming, because any modification on the driver level requires a new complete system generation. By partly automating and simplifying the procedures the total time for generating a new operational system has been reduced to two hours.

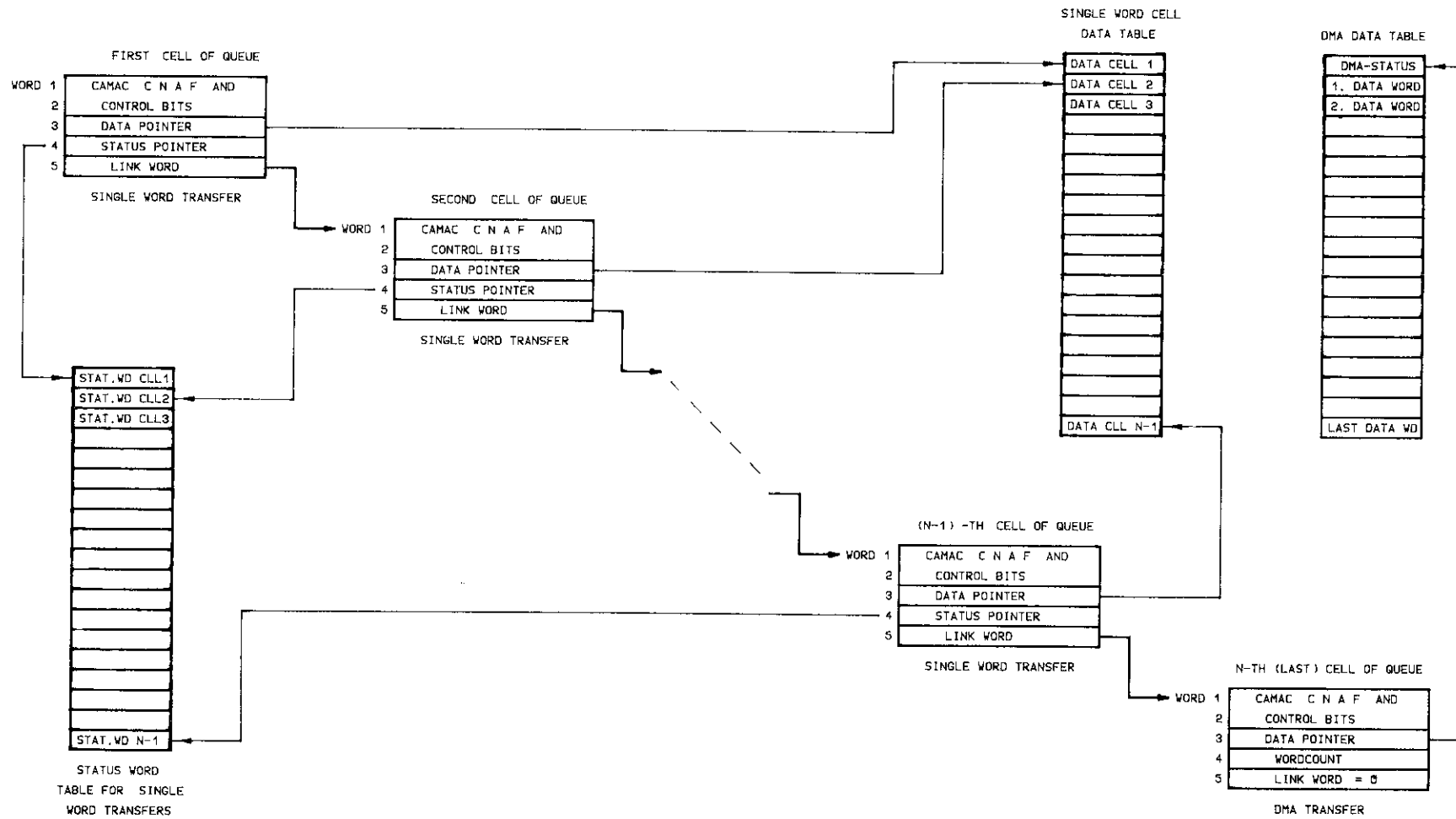

Fig. 4 Cell queue for CAMAC driver input and related data tables

5.3 Equipment drivers and their synchronization

In the control software structure a device handler deals with PDP-11 UNIBUS interface modules. A second class of software driver handles groups of CAMAC modules, each interfacing to a distinct subsystem of the process. The lines which divide the whole CT system into subsystems are mainly determined by the physical isolation of the equipment and by the responsibilities of the engineers involved.

At present the process is divided into five subsystems (see Section 6, especially Fig. 8). All are controlled via crates in the parallel branch highway. The principal control functions of each subsystem, such as data acquisition, fundamental data treatment (fast surveillance and fast displays), translation of higher-level task commands into CAMAC, or other actions, are treated by software drivers called equipment drivers (EQDs). Owing to the high speed requirements all EQDs have to be core resident. Unlike a device handler, each EQD is an active task which performs autonomous actions at defined moments during the PS cycle as well as answering at any moment the requests from higher-level control tasks.

The synchronization of the EQD tasks during operation as well as their start-up and shut-down are controlled by a high-priority scheduling task. It contains the interrupt service routines linked to the PS interrupt pulses T0 (CT ejection instant), T1 (PS cycle start), T3 (end of PS cycle flat top) and T6 (start of PS supercycle). A further clock interrupt $[T2 = (T0 - T1)/2]$ is created between the events T1 and T0. Tasks in the CT control system can be notified of the interrupts by two different features supported in RSX11-M. For less time critical routines, event flags are set by the interrupt routines to which the waiting tasks respond in less than a few milliseconds. High-priority real-time processes, such as critical data acquisitions, are started by a software interrupt mechanism (AST) initiated via the hardware interrupt routines. The response time for ASTs is of the order of a few hundred microseconds.

The scheduling interrupt routines dynamically update certain PS-cycle-dependent information in a common data area used by all tasks of the control system. These data are concerned with the identification of subcycles in a PS supercycle, modes of PS operation, programmed beam intensities and the presence of PS pulse trains.

Figures 5 and 6 show the general flow chart and the timing diagram for all EQDs of the system. Most of the data acquisitions are made just after the ejection instant T0 or at the end of the PS cycle flat top T3. Simple checks and fast displays are started at cycle start T1 or at the event T2.

The EQD is the central control node for each subsystem. It contains a table with the working reference data for the connected subsystem equipment and handles the updating of the work data and standard sets for operation in the CT data bank on the disk.

5.4 Interpreter language and intermediate control tasks

The usefulness of an interactive interpreter language for higher-level process control software has already been emphasized elsewhere¹⁾. The ease of writing test and simple control procedures has been appreciated, especially during the development phase of the control system. Engineers and technicians not generally familiar with programming techniques were able to write programs in interpreter language for their immediate needs. During the early

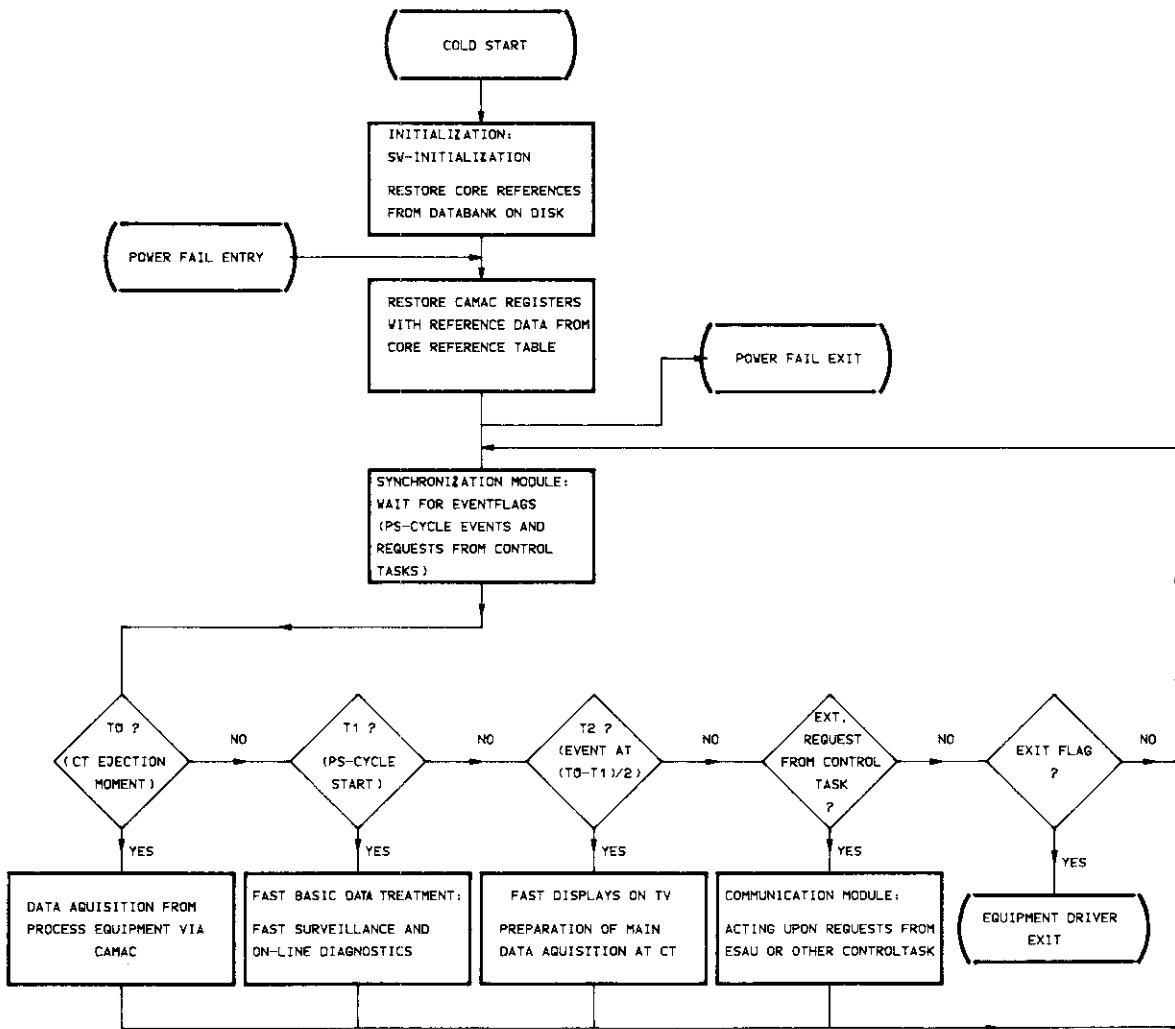

Fig. 5 General flow chart of an equipment driver

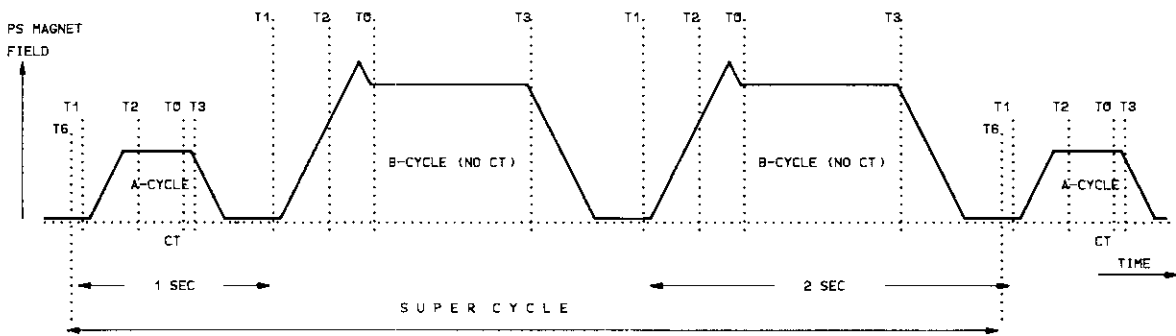

Fig. 6 Timing interrupts for equipment driver synchronization

phase of CT operation, easy modification of the control programs increased speed and flexibility considerably. In the initial design phase, several interpreter languages were available on PDP-11 computers: BASIC, FOCAL, NODAL, and ESAU. However, none of these could be used straightaway for the process control. Finally a choice was made for ESAU, the only language supported at that time in the PS⁶).

ESAU is a single user interpreter, only one ESAU program can be active at a time. However, one single background activity may run in parallel with the execution of the main ESAU program. The limitations of workspace for the ESAU text are overcome by the use of overlay facilities, which allow the partial or full overlay of the ESAU program text.

ESAU programs have full access to the common data area, the common library, and the synchronization tools of the CT control system. Direct CAMAC transfers can be made in single word as well as in DMA mode. This can be useful under test conditions when the EQDs may be bypassed. Displaying data with ESAU on the CAMAC-driven TV screens is almost as simple as writing text on the VT05 terminal.

For about 70% of the implemented control functions a reasonable distribution of processing between ESAU and EQDs is achieved. However, in several cases, the disadvantages of ESAU, namely low speed, limited workspace and single user mode, require the inclusion of quite complicated control functions in the EQDs, which are then in danger of becoming heavy monoliths. Therefore a second hierarchy of high-level control tasks was created. Running in parallel with ESAU, these intermediate control tasks can be written either in assembler language or FORTRAN. They increase the modularity of the whole system and permit the execution of closed-loop control procedures, slow equipment parameter changes (e.g. septum movements), or performance statistics in parallel with normal operation.

The introduction of intermediate control tasks into the control system software structure also circumvents the bottleneck of the limited number of EQDs (maximum of eight) given by their inherent synchronization mechanism. An intermediate control task can replace an EQD, provided the fundamental control principles are followed and the required execution speed is not too critical. The possibilities for extending the present control system have been thus considerably increased.

5.5 Communication in the software structure

The system is designed such that the communication data volume exchanged between the different software elements (drivers, ESAU, control tasks) is minimized. The communication facilities offered by RSX11-M are sufficient, except for the data acquisition from the CAMAC interface where relatively high-speed and high-volume data rates (200,000 baud on an average) have to be handled. As described in Section 5.2, the CAMAC data are transferred from the interface crate modules directly into the relevant task areas, where they are processed so avoiding useless data shuffling in the computer memory.

Figure 7 shows a logic flow diagram of the CT control system software structure, demonstrating the communication paths between the different elements and the logical relationships between the various software and hardware levels. A communication software package has been developed which enables each control or driver task to communicate with the other control programs and the ESAU interpreter, whilst respecting a fixed communication format and the general synchronization rules valid for the system.

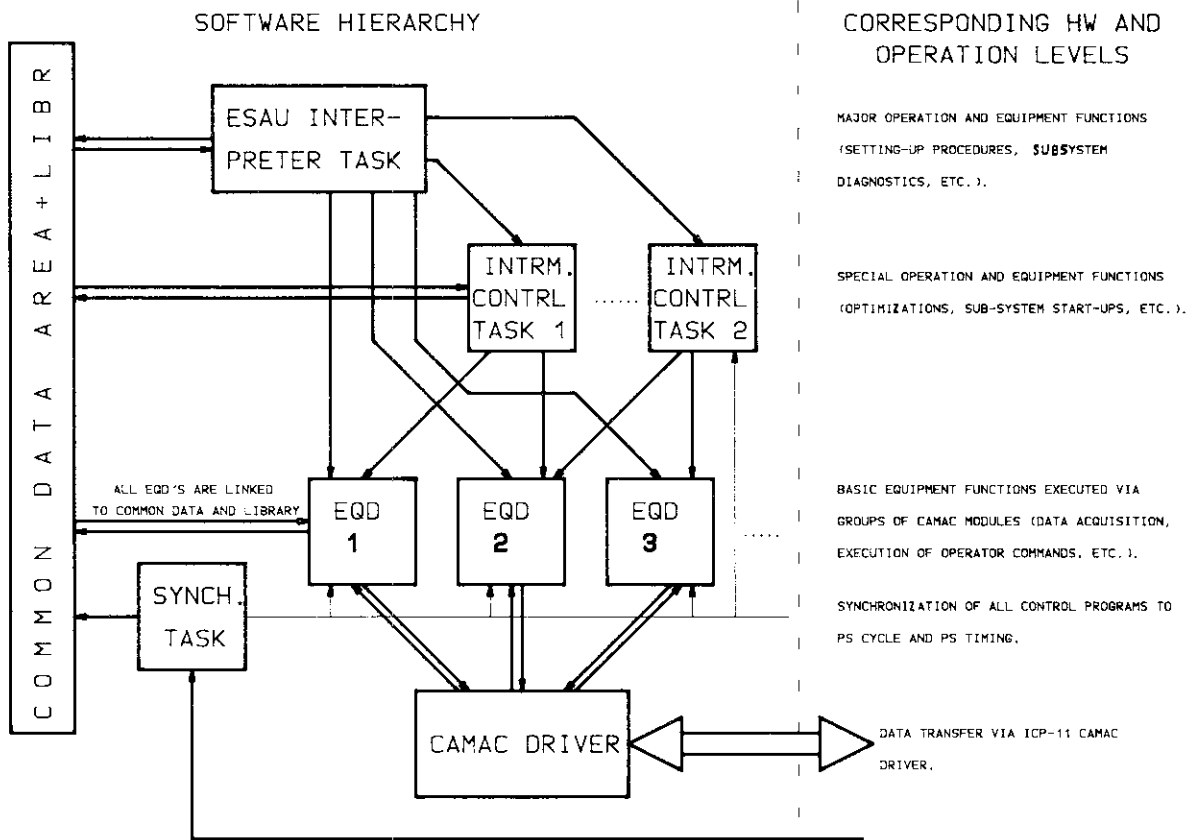

Fig. 7 Data flow in the continuous transfer control system software structure, and correspondence of hardware and software levels

The simplest form of communication passes via the system common data area contained in the core-resident common system library, which is partly read-only, partly read-write accessible for normal control tasks. The general means of communication is based on the send-receive directive features of RSX11-M. A communication packet has been standardized to transfer up to six parameters (P1, ..., P6) between control tasks and EQDs. An example for a setting in an ESAU program is

$$\text{SET TASKX}(P1,P2,P3,P4,P5) = P6$$

or, for an acquisition in a FORTRAN task:

$$A(P3) = 2.5 * \text{TASKY}(P1,P2,P3,P4,P5)$$

where TASKX and TASKY may be EQDs or intermediate control tasks.

Owing to the quite diverse control functions and equipment properties, the parameter use is not inflexibly standardized. The six parameters may specify subunits or subfunctions of equipment, flags for switching on or off control tasks, and also complex actions such as complete recovery or saving procedures for a subsystem. The only convention followed is that P6 is used for value transfer of control variables, such as currents, voltages or status data.

6. FEATURES OF THE SUBSYSTEMS AND THEIR CONTROL SOFTWARE

6.1 General remarks

Figure 8 is a synoptic diagram showing the division of the process into separate subsystems. Though interacting with the beam these are widely independent, except for the timing subsystem, which ensures the synchronization and sequencing of the other subsystems, the CT computer, and the external users of the ejected beam (PS, TT2, SPS).

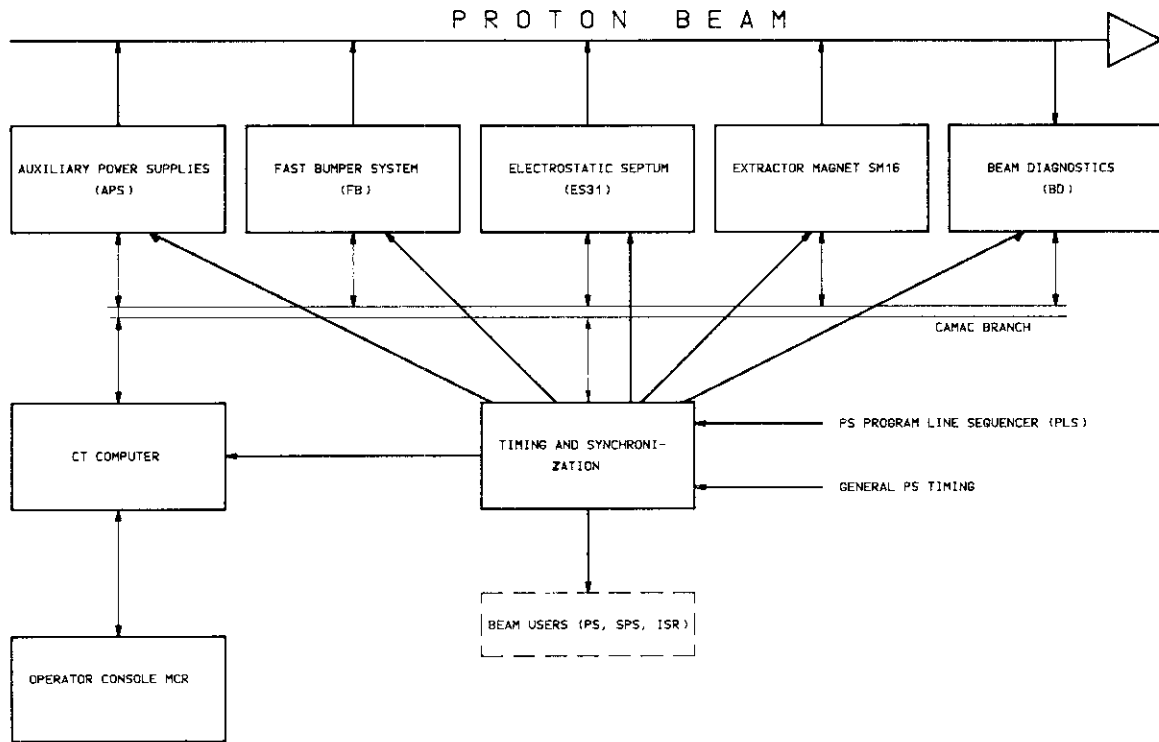

Fig. 8 Synoptic diagram of continuous transfer subsystems

6.2 Fast bumper (FB) system

6.2.1 General features

The process requires the beam to be steered across the electrostatic septum by a modulated fast bump, the degree of modulation being adjusted from turn to turn to maintain constant intensity of the extracted beam (see also Section 2).

The fast bumper (FB) system comprises dipole magnets, so located as to give the desired bump to the beam, and associated pulse generators (Fig. 9). The required excitation for the dipoles is an amplitude-modulated current pulse with independent amplitude adjustment of each step. This pulse is derived from the combined effects of the pedestal (PGA and PGB) and staircase (NSG) pulse generators; the former provides a rectangular pulse covering the maximum possible ejection time and the latter an 11-step pulse. Figure 10 shows a simplified schematic of the staircase pulse generator. The principle is to charge individual pulse-forming network cables (PFN1-PFN11), corresponding in time to the PS revolutions, by their

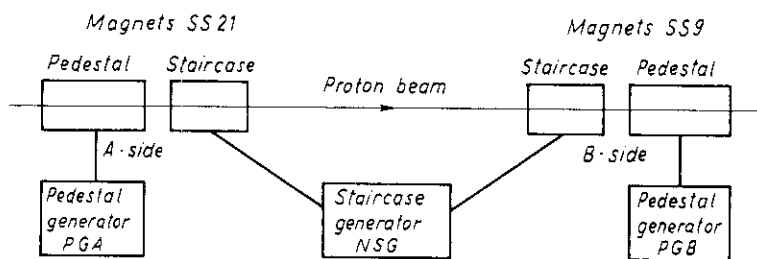

Fig. 9 Fast bumper system block diagram

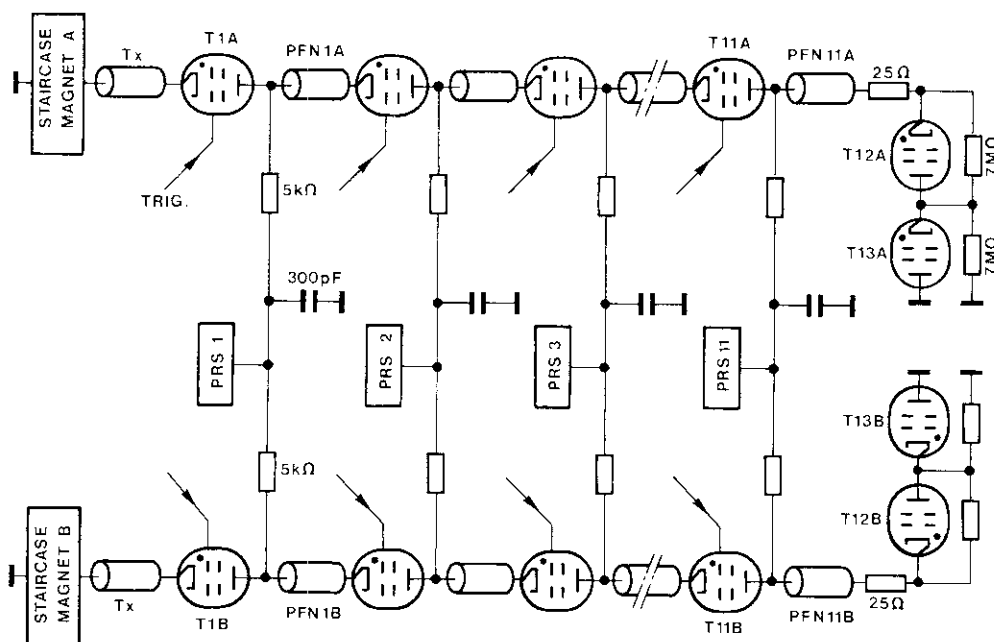

Fig. 10 Schematic of staircase pulse generator

respective resonant power supplies (PRS1-PRS11) and then to generate the pulse by controlled switching of the thyatrons (T1-T11). The staircase pulse generator can be considered as 11 series-coupled pulse generators, further duplicated to excite the two dipoles of the fast bump.

Installed spares (RSG and PGR - see Fig. 11) are available for both types of generator. They are brought into service by motorized switches (RSG) or manual connections in the central building (PGR). This increases the complexity of control and diagnosis. High voltages (up to 40 kV) and fast synchronized step switching (100 ns rise-time) in the staircase generator add to the problems. In particular, the use of series-connected high-voltage pulse generators requires that the absolute and differential PFN charging voltages stay within defined limits determined by the system insulation level and the thyatron ratings.

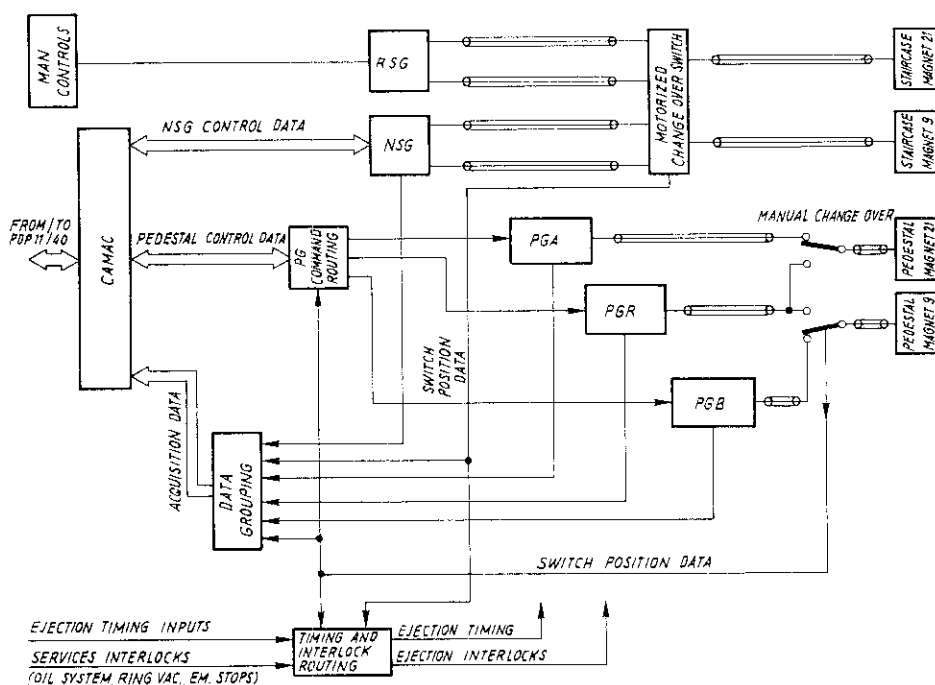

Fig. 11 Fast bumper controls schematic

A current pulse wave form of the FB system is shown in Fig. 15b (see Section 6.5); it is the sum of the pedestal and staircase magnet currents. The relative step heights can sometimes be zero or negative.

6.2.2 *FB control*

Figure 11 shows the FB controls block schematic together with the main items to be controlled.

6.2.2.1 *Generator selection and control mode*

To reduce the FB control software complexity and improve the system reliability, the use of the spare generators (RSG, PGR) results in automatic rerouting of controls, interlocks, and timing pulses by hard-wired logic. The generator taken out of service is automatically relegated to an "on test" status and may be repaired without disturbing the normal ejection process. All generator changes are given to the computer as part of the FB status data, and are used by the software to generate display and warning messages, and to reroute PFN voltage-setting data.

6.2.2.2 *Equipment protection and fault analysis*

Apart from protection by hardware interlocks, the FB equipment is also protected via the control system against faulty manipulations which may trip the FB generators. The interdependence of the different parts of the FB system is such that the data obtained from the hardware protection require processing before they can be used to generate displays. However, in certain cases, the method of data collection removes the need for further treatment, for

example in the use of scanning surveyors to detect the first interlock down in an interlock cascade. Logic is incorporated at the local hardware display level to aid the specialist observer in fault diagnosis.

The protection data available are sufficiently comprehensive to allow fault-analysis programs to be implemented profitably. As an example, data from three measurements made at critical points on each of the PFN charging wave forms may be analysed to diagnose resonant power supply faults difficult to determine by other means.

6.2.3 FB control software

The FB EQD handles data acquisition and treatment and is synchronized in the standard system manner as discussed in Section 5.3. The external request-handling and data-display routines are adapted to the distinct features associated with the hardware. The general use of the communication parameters in the FB EQD is demonstrated below. An EQD subroutine handles all external requests made from a control program to the equipment driver and can be referenced by any ESAU program statement (SET, TYPE, or WHILE loops), e.g.

```
SET FBMP (P1,P2,P3,P4,P5) = VALUE
```

where the integer arguments P1 to P5 and VALUE have been designated as:

P1 = LOGICAL EQUIPMENT (NSG, PCA, etc.)
P2 = SUB-EQUIPMENT (steps 1 to 11)
P3 = DISPLAY TYPE
P4 = OPERATION
P5 = CAMAC XQ RESPONSE
VALUE = CURRENT, VOLTAGE, etc.

The argument P4 defines one of four operations:

- 1) SET - load CAMAC with binary data
- 2) RETURN - return acquired data
- 3) DISPLAY - turn on/off selected displays
- 4) DISK - read or write data to/from disk.

For each specified type of operation, the remaining arguments have operation-dependent meanings, which need to be defined in the command.

The FB system has its own main interactive control program, which has the following features: direct control of the FB status, setting of PFN high-voltage levels and software reference limits, and local analog-to-digital converter (ADC) timing presets. Entering the control program automatically loads into the FB CAMAC registers the work file reference values, which are updated on the disk data bank at each program exit. A voltage-setting algorithm checks all values to ensure that the step-to-step reverse, forward, maximum and minimum limits will not be exceeded. A real-time display routine contained in the EQD can be switched on and runs during each CT cycle. This causes the acquired data to be treated and displays information and error messages, enabling the operator to see from pulse to pulse any change in the FB performance.

All disk-stored data sets for any of the 2, 3, 5, and 10 turn modes of operation of the FB can be displayed by use of a subprogram within the main FB control program. This also applies

to the display of faulty interlocks. Each of these specific functions is performed by different small subprograms swapped into the ESAU working area to execute the particular task selected by the operator.

6.3 Timing system

The CT timing is the only subsystem linked with all other CT equipment. Each CT subsystem receives one or two master triggers from the timing to synchronize its own dedicated timing hardware.

6.3.1 Timing hardware description

The timing system is composed of five independent hard-wired units called timing zones. Each zone is devoted to its own ejection operation, the CT being one such operation.

As shown in Fig. 12, a timing zone has a slow and fast part. The slow part defines the coarse ejection instant (C600) in the PS magnet cycle. The fast part (or fine timing) is synchronized to the revolution frequency of the proton bunches of the PS (RF/20) and to the bunches themselves (RF train).

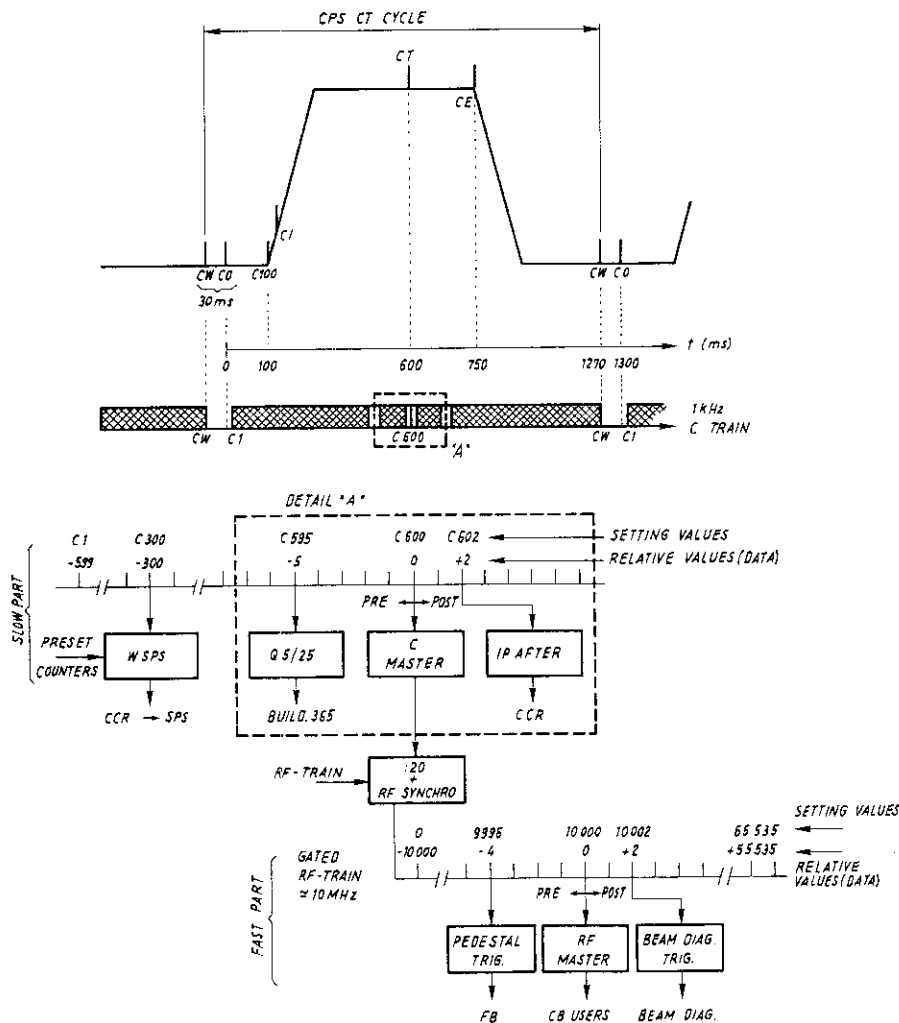

Fig. 12 Schematic of continuous transfer timing zone

In each zone the master counter is the key module. All other counters (around 30 per zone in total) generate pre- or post-pulses and are referred to the master by software. Two preset counters fit in one CAMAC module⁹⁾. Buffer registers avoid refreshing of the timing data at each PS cycle. All presets of a timing zone are located in the same CAMAC crate. The counters of either part (slow or fast) have consecutive CAMAC addresses, starting from the master preset's address. This permits the setting of all counters of the same part in one DMA transfer (auto-increment mode). The level shifters and fan-outs for ingoing and outgoing pulses are built in NIM modules. The pulses for distant users are sent through blocking oscillators and are transformer coupled.

6.3.2 Timing software

There exist two EQDs. One deals with the CT timing zone on the parallel CAMAC branch, and the second with all four zones of the fast ejection timing on the serial CAMAC branch.

Each EQD calculates the absolute CAMAC settings of the presets, starting from the master setting and the relative offsets of the pre- and post-pulses. It communicates with the software CAMAC driver to prepare a single write or read CAMAC transfer (access to a slave preset) or a DMA transfer in CAMAC auto-increment mode when a master preset is concerned. After intermittent CAMAC faults and power failures the preset buffer registers are automatically restored with the last used reference values.

Each zone has its own interactive control program which follows the structure of the hardware with subprograms for the slow and fast presets. The operator deals only with the absolute value for the master preset and the relative offsets for the others.

6.4 Auxiliary magnet power supplies (APS)

6.4.1 General description

The function of the auxiliary magnets has been described in Section 2. One pair of the slow-orbit bump magnets (SOB 16) and the quadrupole pair are also used in the fast ejection process to the Intersecting Storage Rings. Their power supplies have thus to be operated at two different current levels. The sequence is programmed by external requests.

The power supplies are of the capacitor discharge type¹⁰⁾, delivering currents of up to 2000 A in a half sine discharge of 5 to 40 ms.

6.4.2 APS controls

The active status control functions are executed via one CAMAC I/O register attached to each supply. An arrangement as shown in Fig. 13 assures the independent functioning of the supplies at two different current levels. Two digital-to-analog converters (DACs) per supply are serially linked to CAMAC and store the reference values which can alternatively be sent to the power supply. The reference value selection is controlled by programmed triggers, which also prepare the routing for the corresponding discharge trigger. Manually adjustable reference voltages can replace the DACs for test or back-up reasons. A combined strobe-reset assures that DAC values do not change during the charge period of the power supply.

The power supplies are equipped with internal digital voltmeters, which measure either the reference voltage or the peak-discharge current. The computer acquisition for all power

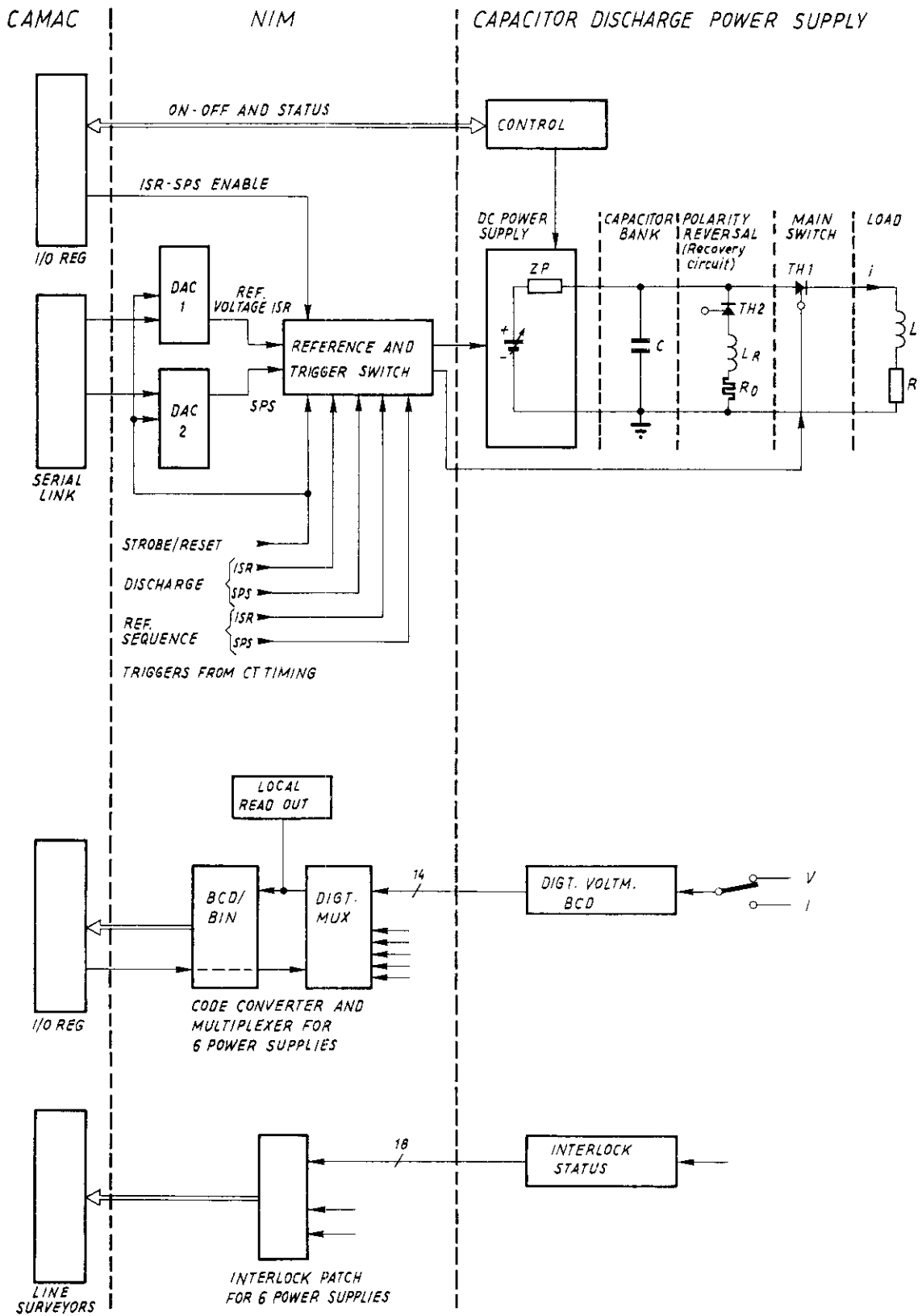

Fig. 13 Schematic of programmed auxiliary magnet power supplies control

supplies is made by a digital multiplexer interfaced to a single CAMAC I/O register with the exception of the interlock and status bits which are acquired by two line surveyor CAMAC modules in common for all supplies.

6.4.3 APS software

The APS EQD handles regular synchronized acquisition of the discharge current values and their surveillance. It sorts the SPS and the ISR data into separate tables for easy read-out by the ESAU control programs. After a computer or CAMAC power failure it brings the supplies back into operation automatically. On request it provides a refreshed display of the APS status and settings.

Two ESAU control programs handle the ISR (fast ejection) and the SPS (CT) operation functions of the auxiliary magnets such that the operators have the impression of working with two independent sets of power supplies.

6.5 Beam diagnostics (BD)

6.5.1 BD elements and features

The BD subsystem in Fig. 14, described in detail in Ref. 11, gives information on the beam properties such as:

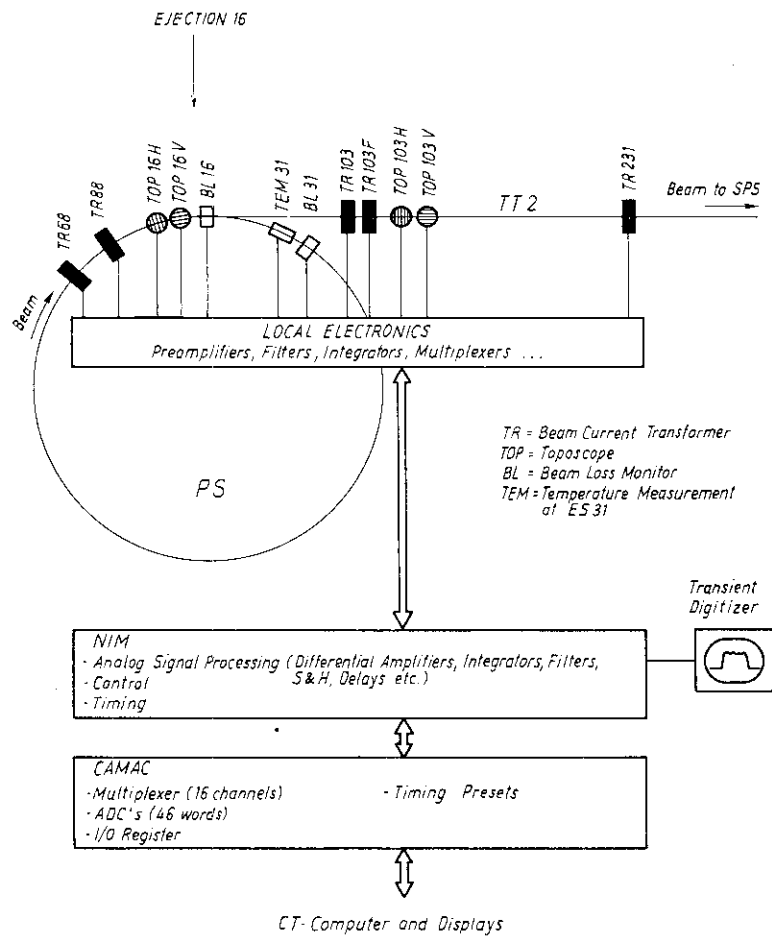

Fig. 14 Continuous transfer beam diagnostics (connected to CT computer)

- time structure of the proton-beam intensity (TR 68, TR 88, TR 103),
- ejection efficiency (TR 68, TR 103, TR 231),
- beam losses (BL 16, BL 31, TEM 31),
- horizontal and vertical beam profiles, position and jitter (TOP 16, TOP 103),
- transverse emittances (via beam profiles).

The circulating and ejected proton-beam intensity is measured with several beam-current transformers. Figure 15a shows a typical analog signal and Fig. 16 a display of ejected beam intensity derived from the analog signal by the control system.

Each toposcope, once moved into the beam, delivers 32 analog signals. They are of similar shape to the beam-circuit transformer signals, but their amplitude is proportional to both beam intensity and transverse beam density (beam profile, Fig. 17).

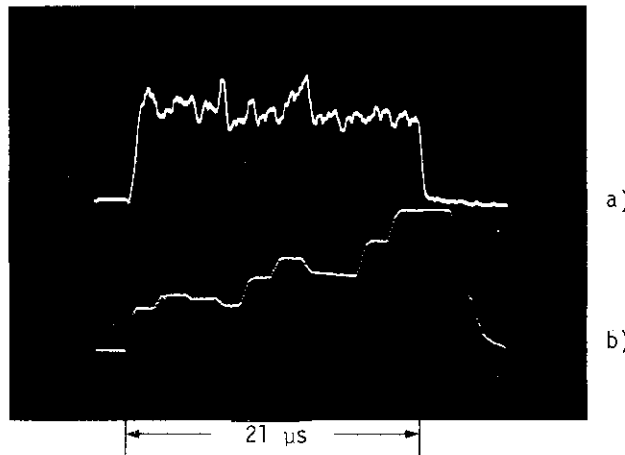

Fig. 15 a) Non-optimized ejected beam signal (TR 103)
 b) Fast Bumper signal (sum of pedestal and staircase magnet currents)

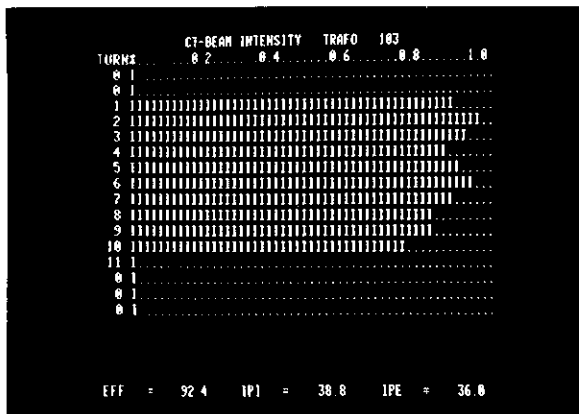

Fig. 16 Transformer signal display



Fig. 17 Horizontal beam profile from toposcope 103 (during 2.1 μ s, corresponding to 1 ejected turn)

Both types of detector signal need special analog processing to prepare them for digital acquisition. For the required analysis of the beam intensity and the beam profile versus time, the number of protons falling into a time interval of 2.1 μ s, corresponding to one PS revolution, must be measured. The beam current transformer signals are filtered such that sequential samplings every 2.1 μ s with one ADC give the number of particles per ejection turn. The beam-profile data are simultaneously gated by 32 fast analog integrators per toposcope and then sequentially digitized.

The internal intensity signals before and after ejection, the different integrated transformer signals, the beam loss monitor signals, and the temperature signal of the electrostatic septum 31 are acquired by standard sample and hold techniques followed by multiplexed analog-to-digital conversion.

The short interaction time of detector and beam requires precise synchronization. A number of computer preset counters provide jitter-free delayed triggers in steps of 100 ns.

6.5.2 BD software

All BD data are acquired from the ADC memories by the BD EQD with a few DMA transfers after the CT ejection instant. The EQD maintains a beam-current display refreshed every PS cycle with CT operation (Fig. 16).

The main interactive BD control program is written in ESAU and is able to

- call and modify the refreshed transformer display mentioned above,
- display all BD timing settings and allow timing modifications,
- move the toposcopes, acquire the profile data, and display profiles, beam positions and beam widths (Fig. 17),
- calculate and display the ejection beam position and its jitter histogram,
- calculate from measured beam widths the transverse beam emittances and the phase-plane ellipse parameters and display them (Fig. 18).

An intermediate control task, written in FORTRAN, displays several essential BD parameters (intensities, efficiencies, and losses) refreshed every CT cycle in digital and

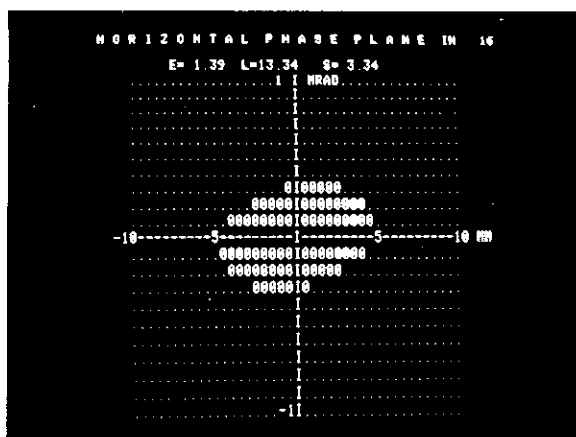

Fig. 18 Emittance display

semi-analog form, when called by the interactive BD control program. Another intermediate control program monitors shaving and ejection efficiencies over intervals of 1000 PS cycles with CT operation. A regular printout on the computer console serves for statistical evaluation of the ejection quality.

6.6 Electrostatic septum (ES)

The ES31¹²⁾ differs from other CT equipment because:

- i) all control variables (high voltage and position) are adjusted via slowly turning d.c. motors;
- ii) the high-voltage supply is of the electrostatic Van de Graaf band generator type, which requires a complicated and lengthy switching-on procedure with some 10^3 to 10^4 CAMAC commands;
- iii) all acquisitions and setting transactions pass via one single CAMAC I/O register; a special-purpose interface is needed between the I/O register on the one hand and the ES31 power supply and the position-regulating motors on the other hand.

The non-standard hardware properties require a careful distribution of the various control functions over several software levels. The operator-initiated start-up procedure may last for 10 minutes, with a large number of data transfers and acquisitions between the computer and the equipment. However, this procedure is autonomously executed in the background, leaving the console free for other operations.

6.6.1 Interactive control program

The operator communicates with the ES31 ESAU program, which creates static display data, checks the operator's input data, initiates the desired actions in the intermediate control tasks, and sets up the desired reference data in the EQD and in the CT data bank. The equipment engineer has access, via a password, to additional procedures, such as septum formation and setting limits for septum positions and voltage.

6.6.2 Intermediate control tasks

High-voltage setting, adjustment of septum or cathode positions, and starting or stopping of the high-voltage generator are controlled by an autonomous task written in assembler language. This task can be called either by the operator via the interactive ESAU control program or, in case of a failure or deviation of the high voltage, automatically by the EQD. It occupies computer core memory only when active.

Another intermediate control task, written in FORTRAN, is used for optimizing the ejection efficiency by variation of the septum angle¹³⁾. This task can be run over a predetermined number of CT cycles or may be scheduled to run repeatedly at fixed time intervals. Optimization is achieved by moving the septum angle within a fixed range around the reference value; at each ejection instant, the angle and the ejection efficiency are measured. By a least squares fit, the angle for which the efficiency is a maximum is determined.

6.6.3 Equipment driver

Similarly to other EQDs, this handles data acquisition, external commands, fast displays, etc. However, in the case of the ES31 the control system is part of a slow servo loop and the EQD detects deviations from the reference data and initiates a correction routine. The

surveillance routine detects faults and power failures and initiates a completely autonomous recovery and auto-restart routine. After a predetermined number of unsuccessful trials the operator's intervention is required.

6.7 Links to other PS control systems

The PS Division is engaged in the introduction of an integrated control system based on a NORD-10 computer network, which will be similar to the existing SPS control system. A CAMAC branch mixer is installed in the CT process interface which allows access from the preliminary PS NORD computer system, giving the development group members training on a running process. During PS operation for physics the CT PDP-11/40 computer has priority for accessing the CAMAC branch and the NORD system is locked out.

On the process interface level a second link exists with the EMAS system¹⁴⁾ handling the controls of other PS ejections, and also of some equipment shared with the CT. The link via a special-purpose CAMAC module simulates the EMAS keyboard and display and is connected in parallel with the standard EMAS console. In this way, the basic EMAS software can be used by higher-level control programs running on the CT computer.

7. OPERATION OF THE CONTINUOUS TRANSFER EJECTION

7.1 Interaction facilities

The CT control system is only one of several stand-alone control systems in the PS. It is therefore important to present the CT process such that the control system users need not learn special languages, syntaxes or procedures¹⁵⁾. Within the limits imposed by the operators' console layout (Section 4), typing effort is rigorously minimized whilst retaining comfortable and fast access to all control functions.

The control programs are grouped into pages and organized in a tree structure of no more than four levels. The video terminal (VT05) is reserved as the input device; it presents the program options available in tree-structured lists to the operator. Every option is briefly described and numbered (Fig. 19). Keying in a number initiates immediately the

```
***** CT CONTROL SYSTEM PROGRAMS *****
CODE  PROGRAM      FUNCTION
-----
1 = CTSET          SETTING FROM FILES
2 = TRIM           CT E.J. BEAM TRIM PROG.
3 = PUMP           FAST BUMP CONTROL PROG.
4 = TIM            TIMING CONTROL PROG.
5 = CTAPS          AUXILIARY PS-CONTR. (CT)
6 = ED             BEAM DIAGNOSTIC PROGS
7 = OPTIM          CT OPTIMISATION PROG.
8 = ISRPRO         ISR CONTR. PROGRAMS
9 = ESS1           ESS1 CONTR. PROGRAM
0 =                TO LEAVE ESU
100 = END          TO GO OUT OF MAIN. ESU

*** IMPORTANT !! TYPE END, WHEN YOU ARE STUCK IN ANY OF THE
                ABOVE PROGRAMS

WHICH PROGRAM ?
```

Fig. 19 Display of the main control program being the root of the continuous transfer program hierarchy

corresponding specific action or opens a new program page. The only convention is that a stroke of the "carriage return" key alone initiates a jump back to the preceding program page or option. A fundamental rule of the program presentation is that every option calls automatically its logical display showing all relevant information corresponding to the action. However, some of the beam diagnostic displays can be combined freely with other programs. The practical result is that it takes only minutes to become familiar with the console. Apart from basic knowledge of the CT process, no written documentation is needed, use of the console being as simple as acting on a push button or a touch panel.

7.2 Specific operational problems

The function of the different CT elements has been treated in Section 2. During standard operation, the auxiliary elements and the septum deflectors can be operated most of the time with constant values. The critical adjustment is that of the step heights of the modulated fast bump; this determines the number of protons contained in every 2.1 μ s interval of the extracted beam. The SPS requires a proton beam with the flattest possible intensity structure. A badly adjusted fast bump adds a drastic modulation to the already present harmonics stemming from the beams history in the Linac, Booster and PS accelerators. The lengthy adjustment requires skill and patience and has to be repeated every time the beam size, or the beam intensity, changes.

Both for good ejection efficiency and small irradiation of PS equipment, it is important to minimize proton losses. Systematic losses of a few per cent occur on the electrostatic septum. The apparent width of the septum depends on the relative angle between proton beam and septum and has to be minimized every time the accelerator and beam conditions change¹³⁾.

7.3 Operation facilities

Three categories of control programs exist, each covering best different aspects of operation.

One set of programs is directly related to the CT hardware subsystems and accesses all acquired parameters and hardware check-out procedures. They are generally intended for hardware specialists for fault finding; they also give a high degree of freedom for operation during tests or process development.

For standard operation the displays and control procedures need to be simpler. A general status display gives relevant information about the whole process. Another program, combining a few selected parameters which act directly on the beam, serves for fast trimming of the process. This trimming program reduces the risk of involuntary misadjustment of vital parameters.

The third group of programs concerns automatic functions. An example is the software link between the FB system and the emittance reduction dipole, which makes the latter follow automatically every adjustment of the former. The minimization of beam losses and the optimization of ejection efficiency are made automatically by adjustment of the ES31 septum angle, as previously described in Section 6.6 and in Ref. 13. The adjustment of the fast bump for the stabilization of the extracted beam intensity flatness is handled by an optimization program described below.

7.4 Closed-loop optimization for extracted beam intensity

There is not much experience yet with closed-loop real-time programs. The most difficult problem is not to find a suitable feedback algorithm but to make the program intelligent enough to converge under all, even abnormal, conditions and this without overloading the computer resources. The intensity-optimization program flattens the intensity structure of the extracted proton beam to its best value under all circumstances. It cannot correct shot-to-shot jitter but only the average behaviour. To perform this the program acquires regularly information about the ejected beam intensity structure from the beam diagnostic EQD. It then calculates corrections for the FB staircase and pedestal amplitudes, taking into account their interdependence as determined by the physics of the beam-shaving process. All corrections are then sent simultaneously to the equipment after checking their compatibility with equipment limits.

A number of checks and statistical treatments are made to allow the program to cope with fluctuations and abnormal conditions. Each time the ejected beam intensity exceeds a minimum intensity the standard deviation of the differences between the collected data and an ideally ejected beam is computed. Data exceeding the minimum deviation within a set of four measurements by a certain amount are rejected. If the fluctuation between measurements is too large their number is increased to eight in order to improve the statistical accuracy of the average of the accepted data.

As in every feedback system the loop gain is a critical value. Chosen too high, it leads to system instability; chosen too low, it increases the response time. In this particular loop the permissible gain depends on the beam size which, in turn, is a function of beam intensity.

The program converges towards an optimally ejected beam within a few minutes (20-30 PS cycles). It can also handle the change between 10, 5, or 3 ejected CT turns automatically. Present limitations are that there must be at least some ejected beam before optimization can start and that the effectiveness depends completely on the quality of the acquired beam information.

8. NOVEL CONTROL FEATURES

8.1 System diagnostics and automatic error recovery

One of the principles of fault finding in a complex system (after failures or performance degradation) is to decompose it into independent subcomponents. Aided by specific off-line diagnostics programs the functioning of the isolated components can be verified. The use of off-line diagnostics software in the CT system is however of limited value, because, in case of trouble, some prior knowledge of the failure source will still be needed. Off-line diagnostics allow test-out of only limited parts of the system, whereas many faults in a complex structure are provoked by the interconnections between the component parts of the system. Off-line diagnostics have therefore to be complemented by on-line diagnostics (meaning diagnostics which run all the time in parallel with the control system). This idea has already been recognized in a previous stand-alone control system in the PS¹⁴⁾. On-line diagnostics can provide immediate localization of failure sources and detection of malfunctioning of processes or equipment, including the control system elements themselves. Further,

such diagnostics are the basis for automatic recovery after failures, automatic fault correction and automatic operational performance improvement, leading to high system availability. However, on-line diagnostics software incurs a high development effort. It represents about 30 to 40% of the total software in the CT control system. On-line diagnostics also may saturate the CPU of a stand-alone process control minicomputer.

On-line system surveillance is an efficient means in a complex process of maintaining control in its fullest sense. Operators must at all times be correctly informed about system status, faults, or bad operation. Choosing the proper balance between on- and off-line diagnostics is not straightforward; often the choice can be made only after a certain period of operating experience.

The diagnostics implemented in the CT system begin with the ejected beam. Efficiency and intensity of the ejected beam are constantly monitored, displayed, and logged. Most of the process equipment is steadily surveyed and, in several cases, automatic recovery actions are started after failures. Automatic recovery can be dangerous and can make certain operations virtually impossible, when applied under all circumstances. In the CT system "self-repair" is generally initiated a few times; if unsuccessful, the system remains in the fault condition. Typical examples for on-line diagnostics are the surveillance of status and voltage settings of power supplies and pulse generators, the surveillance of equipment hardware interlocks or the surveillance of complete subsystems such as the ES31 or the CT timing, which are automatically brought back to their current status following an intermittent fault. Whenever automatic recovery is not implemented, the operators receive error or alarm messages. Care is taken to prevent the number of error messages from inundating the operators under exceptional accelerator or control-system conditions. Each single CAMAC transfer in the control system is checked for proper execution. The actions of the operators in the PS MCR are monitored. The use of any control program, the setting of certain key parameters, and any changes in operation mode, are logged on the computer console printer (Fig. 20).

```
(RE)START OF MAIN-PR. 09:11:32 09/02/78
(RE)START OF FBUMP 09:11:53 09/02/78
ES31 AUTO RECOVERY (PWR STAT FAULT)
ES-LOG::000012 #HV= 420 #E= 0 #R= 0 #C= -B1 #
CR 981 #SR= 599 #A= 1 # 09:12:33 09/02/78
(RE)START OF MAIN-PR. 09:13:19 09/02/78
(RE)START OF BD-PRG 09:13:30 09/02/78
(RE)START OF MAIN-PR. 09:18:55 09/02/78
(RE)START OF ES31 09:19:06 09/02/78
----- 09:20:03 09/02/78 SA = -50
----- 09:23:31 09/02/78 HV = 100
(RE)START OF MAIN-PR. 09:23:55 09/02/78
(RE)START OF OPTIM 09:24:03 09/02/78
(RE)START OF MAIN-PR. 09:26:40 09/02/78
UPD DISPLAY MEMORY RESET 09:27:20 09/02/78
ESAU OFF 09:27:35 09/02/78
```

Fig. 20 Example of computer console print-out. (The automatic recoveries of the ES31 subsystem and a CAMAC display memory module were here artificially initiated.)

8.2 On-line software development and implementation

The absence of a link to a program-development system requires the control system to support flexible program-development facilities in parallel with CT operation. File handling, editing, assembling, compiling, task building and the production of listings is run in the background with low priority in order not to disturb the real-time control programs. All vital control software, including the ESAU text files and the main system programs and libraries, are stored and accessed on the non-removable system disk. Most of the program-development work and the storage of source files is done on removable disk units. During ejection operation, program development can proceed on two video terminals.

Program development and modification, control software testing and implementation of new process equipment can be done on line, provided short perturbations of operation are accepted in case of incorrect software. ESAU programs can be changed, tested, and eventually replaced by another version within a few seconds. Equipment driver software can be modified quickly, so that at worst a few ejection pulses are lost. Modifications of intermediate control tasks are much less critical, since they do not require a control system shut-down and restart. The great development flexibility of the system enables equipment implementation during the PS operation periods, provided the CAMAC branch connection can be made without influencing the operation of other process equipment.

9. RELIABILITY

9.1 Major reliability features

Minor breakdowns and interruptions of the control system or its components can often be supported. One reason for this is because the equipment continues to run with the latest settings. Many intermittent faults can be eliminated by either implementing double checks in a number of active control operations or by detecting errors automatically and correcting them. Any power failure in a CAMAC crate generally extinguishes all CAMAC register contents. The control system detects such power failures either directly (CAMAC and PDP-11/40 are powered from the same mains source) or indirectly via on-line diagnostics which initiate immediate recovery actions without operator intervention.

Whenever the control system is blocked or has crashed, the availability is largely determined by the ease of restarting or coldstarting from the MCR console. A coldstart can be initiated by pushing a single button in the MCR. The system comes back automatically and the operator only has to specify the type of operation desired. Then the latest valid reference values are restored to the equipment and the process continues to run as before. A normal control system restart requires a single keyboard command at the MCR console.

9.2 Operational experience

The CT operation started in April 1976. At that time only the very fundamental control functions for running part of the equipment with the control system had been realized. Since then the control system and the equipment have undergone major extensions and modifications. Experience concerning performance and reliability is therefore not that for a stable system; but where in accelerators do stable control systems exist?

All major failures of the control system happened after modification or servicing of the control hardware. During the first year of operation there were two serious computer breakdowns, necessitating a change-over of about 2 weeks to the PDP-11/10 back-up. Less dramatic failures were due to the CAMAC interface. The multiwire branch cables, the cable connectors, and the crate controllers on the parallel branch, were prone to failure after disturbance. Some CAMAC modules, such as display drivers or DACs for the FBs and APS, sometimes blocked the functioning of the control system.

Software failures were of a different nature. In the development stage they could be classified more as the consequence of insufficiently tested programs. Many faults became apparent only in unforeseen or abnormal situations (e.g. new modes of PS ejection operation). Other sources of malfunctioning were due to the software not being sufficiently foolproof against wrong manipulations by the operators.

From May 1976 up to the end of the year 1977 the unavailability of the control system sums up to less than 30% of the over-all unavailability of the ejection system, which itself was 30 hours out of more than 5000 hours of CT operation during that period¹⁶⁾. The quoted unavailability includes computer failures during hardware and software installation and operation, failures of the equipment interfaces, time lost by wrong operator actions, and fault repair time. Not included is the time when the PDP-11/10 back-up was active. For a control system under full development a failure rate of less than 3% is considered acceptable.

10. FUTURE IMPROVEMENTS

Although the CT control system will be eventually integrated into the future PS control system, a number of improvements and extensions still have to be made.

Frequent power failures during thunderstorms make auto-restart programs to bring all subsystems back to an operational state more necessary. For some subsystems these programs are not yet operational.

Extensive diagnostics have been foreseen for hardware and software in the entire system, but are not yet fully implemented. Especially important diagnostic functions in the FB system hardware, such as analysis of thyatron self-triggering, have to be added with priority.

The back-up facilities in the case of a computer breakdown are considered too marginal. A full back-up is under development by upgrading the spare computer of the TT2 beam-line control system, which can then replace either of the two computers.

Slow variations of PS performance can be compensated by FB adjustments in the optimization program. However, this program does not deal with pulse-to-pulse variations. Measurements of relevant beam parameters early in the acceleration cycle with anticipated corrections of settings in the CT equipment may be desirable. As an alternative, a study will have to be made, to see if beam fluctuations cannot be better suppressed at their origin.

A very substantial extension of the system will have to be made for the SPS Multibatch Filling Project. The introduction of new equipment to be controlled by the CT control system, the decreased PS cycle time, and the different synchronization requirements, imply many changes. Moreover, access will be needed to other equipment. For example, the PS full aperture kicker magnet system will, apart from its role in the fast ejection, be an integral part of the above-mentioned project. Other links will be needed to the extractor magnet in straight section 16 and to some of the elements in the TT2 beam line.

11. CONCLUSIONS

Conclusions about the conception and exploitation of a control system can best be drawn by considering what would be repeated and what would be changed if the system were to be rebuilt today. Treating separately the principal constituent parts of the CT control system gives the following picture.

Computer: The DEC PDP-11/40 computer with the RSX11-M operating system has been satisfactory. The choice of a computer for control systems of this type should be mainly based on available software support.

Equipment interfacing: The parallel CAMAC branch highway would not be repeated. Instead serial CAMAC would be used, because it is more fail-safe and inflicts less degradation on the control system in the event of chassis or module failures. More critical selection of interface modules would be made to decrease the real-time load and synchronization difficulties for the computer. The data volumes to be handled by the process control computer would be reduced by allowing certain equipment to perform autonomous functions aided by microprocessors. Difficulties met in interfacing the control system to some of the older, existing items of equipment would not occur in a new system where coordinated design of control system and equipment would be expected from the outset.

Operators' console: Control from the MCR console has been simple, effective, and rapidly learned. Much appreciated have been the simultaneous refreshed displays of controlled equipment variables and beam data. Colour displays and graphics could be improvements in a future system, provided their introduction would not destroy the present simplicity.

The software structure: This has allowed non-specialized engineers to bring the system to full operation with a minimum of professional guidance. The flexibility of the chosen structure has been much appreciated, especially with respect to the on-line modification or extension of the controls. The implementation of an interactive interpreter language has enabled fast and easy realization of test and control programs.

Diagnostics: On-line and off-line diagnostic software, supported by local manual controls back-up, has speeded up fault finding and increased ejection availability. It has been recognized that MCR operators should be informed of system failures by comprehensive messages, but nevertheless be kept free of detailed hardware parameters, whereas equipment engineers need full parameter access for maintenance and repair.

Automatic procedures and real-time process optimizations have been the most rewarding outcome of the control system. Automatic recovery, though not fully realized throughout the control system, has contributed to over-all system availability. The iterative adjustment of the fast bump profile is fast and the closed-loop stability for numerous modes of operation excellent. Such on-line optimization procedures would be repeated, even more extensively, on any similar future project.

To conclude, the continuous transfer stand-alone control system has been designed, constructed and run-in by a small team in a time of two years. The approach for developing a control system by mainly non-computer specialists seems effective in the CERN environment, where the people involved are of high level, easily motivated, and able to progress in an independent manner.

Acknowledgements

The CT control system is the result of the collaboration of many people from the Acceleration and Ejection Group and from other PS groups. The authors would like to express their gratitude for this joint effort.

Particular thanks are due to:

- the Operations Group, especially J. Boillot, for their constructive "feedback" and for their patience during the running-in period;
- the Computer Control and Instrumentation Group, who gave support to this project and made available various computer and peripheral hardware, and especially J. Gamble (now ISR) for the discussions on system software layout and for his effort in adapting the available ESAU interpreter to our needs;
- the Synchrotron Magnet Group, especially F. Rohner, M. Thivent and R. Tinguely, for preparing the auxiliary magnet power supplies and the electrostatic septum for computer control;
- M. Lee (now at the University of Maryland) and H. Shaylor (now at the University of Birmingham), who made substantial contributions to the layout and the development of the system software;
- last, but not least, L. Ghilardi and L. Pomentale who have enthusiastically done the preliminary typing, G. Knott who patiently did most of the drawings, and the Scientific Reports Typing Service who arranged and typed the final version of this report.

REFERENCES

- 1) M.C. Crowley-Milling, The design of a control system for the SPS, CERN 75-20 (1975).
- 2) P. Pearce and H. Riege, Proposition for the controls of the fast bumper generators of the continuous transfer system, CERN MPS/AE/Note 74-13 (1974).
- 3) C. Bovet, D. Fiander, L. Henny, A. Krusche and G. Plass, The fast-shaving ejection for beam transfer from the CPS to the CERN 300 GeV machine, Proc. Particle Accelerator Conf., San Francisco, 1973, IEEE Trans. Nuclear Sci. NS-20, 438 (1973).
- 4) A. Krusche, Proposal for the final layout of the continuous transfer system, CERN MPS/SR/Note 73-33 (1973).
- 5) D. Fiander, D. Grier, P. Pearce and K. Metzmacher, A modulated fast bump for the CPS continuous transfer, Proc. Accelerator Conf., Chicago, 1977, IEEE Trans. Nuclear Sci. NS-24, 1340 (1977).
- 6) H.R. Shaylor, A general-purpose CAMAC handler for RSX11-M, Generating a system with the dual CAMAC driver, CERN/PS/AE/Note 76-2 (1976).
- 7) P. Mead, The new Linac control system software, CERN/PS/LIN/Note 76-11 (1976).
- 8) J. Gamble and J. Stark, ESAU Version I, CERN/MPS/CCI/Note 75-15 (1975).
- 9) J. Boucheron, Technical specifications for a CAMAC dual preset counter, CERN/MPS/AE/Note 74-36 (1974).
- 10) F. Rohner, Technical specifications for programmable capacitor discharge type power supplies for the auxiliary magnet system of the CPS, CERN/MPS/SM/Spec. 74-4 (1974).
- 11) G.C. Schneider, The continuous transfer beam diagnostic instrumentation and computer presentation, CERN/PS/AE 78-1 (1978).
- 12) J. Bleeker, C. Germain, M. Thivent and R. Tinguely, Development of an electrostatic septum at CERN for high-energy proton synchrotrons, CERN/MPS/SR 72-4 (1972).
- 13) H. Riege, On-line optimization of the continuous transfer ejection efficiency, CERN/PS/AE 78-7 (1978).
- 14) D. Bloess, H. Kugler, P. Pearce and H. Riege, The ejection computer system, CERN/MPS/SR/Note 73-2 (1973).
- 15) M. Lee, CT-control system, CERN/PS/AE/Note 76-16 (1976).
- 16) D. Dekkers, Opération du PS, Nos. 57 to 70, PS/OP/Min 76-21 to 76-36 (1976) and CERN/PS/OP/Notes 77-1 to 77-25 (1977).