



Lawrence Berkeley Laboratory

UNIVERSITY OF CALIFORNIA

LBL--16327

DE83 016620

To be presented at the 7th Symposium (1983 International) on Ion Sources and Ion Assisted Technology (ISIAT '83) and the 4th International Conference on Ion and Plasma Assisted Techniques, (IPAT '83), Sakyo-ku, Kyoto, Japan, September 12-16, 1983

HIGH-CHARGE-STATE ION SOURCES

D. J. Clark

June 1983

NOTICE

PORTIONS OF THIS REPORT ARE ILLEGIBLE.

It has been reproduced from the best available copy to permit the broadest possible availability.

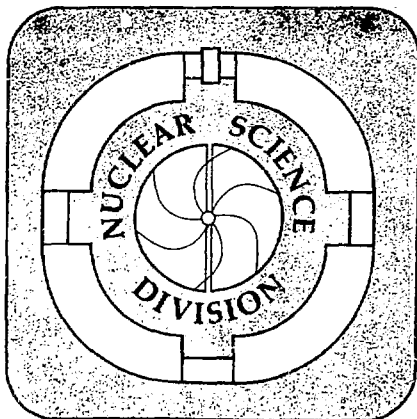

MASTER

REPRODUCTION OF THIS DOCUMENT IS UNLIMITED

DISCLAIMER

This report was prepared as an account of work sponsored by an agency of the United States Government. Neither the United States Government nor any agency thereof, nor any of their employees, makes any warranty, express or implied, or assumes any legal liability or responsibility for the accuracy, completeness, or usefulness of any information, apparatus, product, or process disclosed, or represents that its use would not infringe privately owned rights. Reference herein to any specific commercial product, process, or service by trade name, trademark, manufacturer, or otherwise does not necessarily constitute or imply its endorsement, recommendation, or favoring by the United States Government or any agency thereof. The views and opinions of authors expressed herein do not necessarily state or reflect those of the United States Government or any agency thereof.

LBL-16327

HIGH CHARGE STATE ION SOURCES

David J. Clark

Lawrence Berkeley Laboratory
University California
Berkeley, California 94720

June 1983

This work was supported by the Director, Office of Energy Research, Division of Nuclear Physics of the Office of High Energy and Nuclear Physics, and by Nuclear Sciences of the Basic Energy Sciences Program of the U.S. Department of Energy under Contract Number DE-AC03-76SF00098.

... 214p

HIGH CHARGE STATE ION SOURCES
David J. Clark
Lawrence Berkeley Laboratory
1 Cyclotron Road, Berkeley, CA 94720, U.S.A.

1. Introduction

Sources of high charge state positive ions have uses in a variety of research fields. For heavy ion particle accelerators higher charge state particles give greater acceleration per gap and greater bending strength in a magnet. Thus higher energies can be obtained from circular accelerators of a given size, and linear accelerators can be designed with higher energy gain per length using higher charge state ions. In atomic physics the many atomic transitions in highly charged ions supplies a wealth of spectroscopy data. High charge state ion beams are also used for charge exchange and crossed beam experiments.

The production and use of highly charged ions has been discussed in a number of conferences. These include conferences at Gatlinburg in 1971 [1] and 1975 [2], the most recent EBIS Workshop at Saclay-Orsay in 1981 [3], a conference in Stockholm in 1982 [4], and the most recent ECR source workshop in Louvain-la-Neuve in 1983 [5].

2. Production of High Charge State Ions

To create multiply-charged ions we must supply the energy to remove the electrons. It can be supplied by using bombarding electrons with sufficient relative velocity, by photons or by high electric fields. For the sources discussed here bombarding electrons are used. For high production cross-section, the electron energy should be 2-3 times the ionization potential.

The cross-section for ionization from one charge state to the next is a function of the ionization potential and the electron bombarding energy. It starts at zero at the ionization potential, reaches a maximum at an electron energy of about three times the ionization potential, and then falls with increasing electron energy.

The time evolution of the charge distribution can be calculated from the cross-sections and the electron beam density. The quantity determining the charge state is $j\tau$, where j is the electron current density and τ is the ion confinement time. A calculation of the time evolution of argon charge states is shown in Fig. 1. This calculation does not include charge exchange with other ions or molecules, or recombination with electrons. The $j\tau$ required for various charge/mass ratios of all atomic species is plotted in Fig. 2. The right hand scale of Fig. 2 is $n\tau$, where n is the plasma density. $n\tau$ is a figure of merit for confinement frequently used in fusion reactors. High charge state ion sources require high electron temperature and only moderate $n\tau = 10^8$ - 10^{12} cm^{-3} sec, while fusion reactors need high temperature ions and a high $n\tau = 10^{14}$ cm^{-3} sec.

The production of high charge states by electron bombardment can be accomplished either by the use of fast electrons on thermal velocity ions in an ion source, or by using fast ions from a first accelerating stage and passing them through a gas or foil stripper. This last method is extensively used in two-stage heavy ion accelerators. The equivalence of fast electrons or fast ions for producing high charge states was discussed by Nagel [7]. For the case of slow ions in a plasma charge states were

calculated by the coronal model. It is valid for low densities, and assumes collisional excitation (ionization) and radiative deexcitation

(recombination), but no collisional deexcitation. The resulting calculated average charge state is plotted versus temperature in Fig. 3. Also shown are measured data of average charge states in foil and gas targets. The relation of temperature and energy scales was derived by setting the average electron velocity in a plasma equal to the ion velocity in a stripper. The coronal model charge states should agree with those of a gas stripper, but Fig. 3 shows that the gas stripper needs 4 times the energy to make the same charge states. With this correction the two curves agree closely. Fig. 3 also illustrates the higher equilibrium charge states from a solid than from a gas.

3. High Charge State Ion Sources

There are several high charge state ion sources used to produce beams in heavy ion accelerators and for atomic physics experiments. The operating ranges of some of these are shown in Fig. 4 for the important

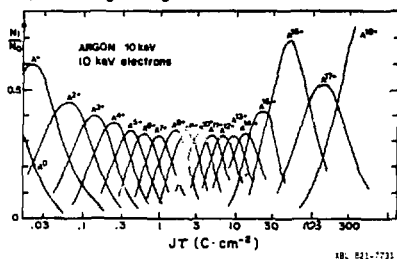

Fig. 1. Charge state fraction for argon plotted versus the ionization factor J_T , for bombardment with 10 keV electrons, from Orsay [6].

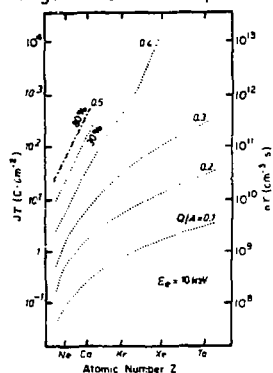

Fig. 2. Charge to mass ratio, Q/A , obtained when atom of number Z is bombarded with 10 keV electrons with ionization factor J_T , from Orsay [6].

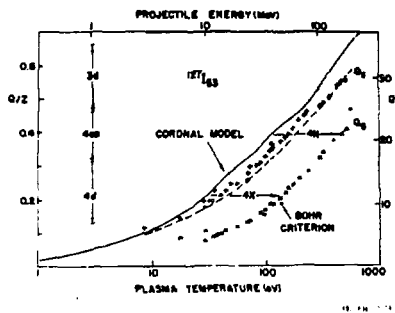

Fig. 3. Average charge states for iodine as a function of plasma electron temperature computed from the coronal model (solid line) [7]. The points are calculated from the Nikolaev-Dmitrii equation [8] for projectile equilibrium charge states in solids (Q_S) and gases (Q_G).

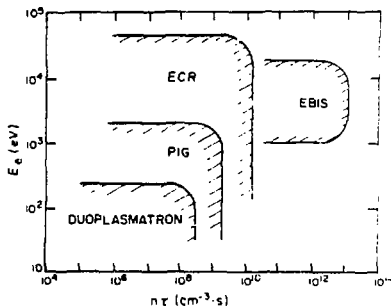

Fig. 4. Operating regions of the most common high charge state ion sources as a function of electron energy (E_e) and n_T .

parameters of electron energy and n_e . The usual source for heavy ion cyclotrons and linear accelerators is the PIG. Advanced sources such as the ECR and EBIS give higher charge states because of their greater values of E_e and n_e , and are now installed in a number of laboratories.

A summary of the charge states available from a variety of ion sources, plasmas, and stripped accelerator beams is shown in Fig. 5. The highest charge states are produced by stripping of beams from high energy accelerators such as the Bevalac. These accelerators are of course an expensive method to produce high charge states, and the challenge to the ion source designer is to generate these high charge states with a much less costly ion source. As shown on Fig. 5 the EBIS comes close to fully stripped ions up to xenon. Although the ECR source has lower charge states, it has the advantage of higher average beam intensity and 100% duty factor.

3.1 PIG Sources

The traditional heavy ion source for cyclotrons and linear accelerators is the PIG (Penning or Philips Ion Gauge). The principles and typical designs were reviewed by Bennett [9] and Green [10].

The principle of operation of the PIG source is illustrated in Fig. 6. In this arc heated cathode version of the PIG the cathodes start cold. The arc is collimated by the surrounding magnetic field. As the arc current builds up the cathodes heat to give thermionic emission which further increases the arc current. The confinement time is just the drift time of the ion along a few cm from formation to extraction. Gas can be fed in at the cathode or anode. Arc currents are 1-15 amps for dc sources and higher for pulsed sources. Arc voltages are 300-2000 volts. The duty factor is normally 20-100% for cyclotrons or linear accelerators, and .1% for synchrotron injectors. The lifetime between source changes is a few hours to a few days for high duty factor operation, and weeks for .1% duty factor operation.

In some PIG sources one cathode is heated by electron bombardment from a hot filament. This heating provides control of emission current and

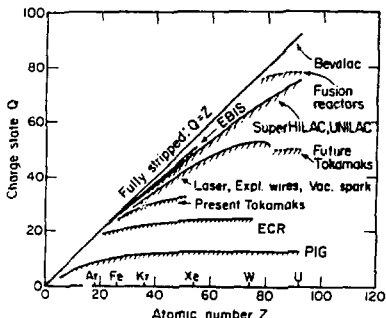

Fig. 5. Charge states produced by ion sources, plasmas and stripped accelerator beams. Upper limits of charge states from each device are shown by lines, solid for present and dotted for future operation.

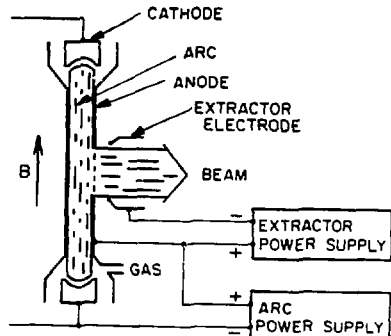

Fig. 6. Schematic diagram of heavy ion PIG source with arc-heated cathodes and side extraction.

thus arc impedance. Sometimes both cathodes are cooled, and electrons are supplied by secondary emission from ion bombardment of the cathode. These run at lower arc current and higher voltage. Solid materials can be fed into the source by an oven, or by placing them in the cathode or in a block in the anode which can be biased negatively to allow sputtering by arc ions.

The current available from a PIG source for several species of heavy ions is shown in Table 1. The PIG source is normally used for charge states up to N^{5+} , Ar^{8+} and U^{10+} .

Table 1. Some typical beam intensities from several high charge state heavy ion sources.

Ion	Q	PIG I(s-1)	ECR(MiniMAFIGS) I(s-1)	EBIS I(pulse-1)
N	2+	1x10 ¹⁵		
	5+	1x10 ¹³	2x10 ¹³	2x10 ¹⁰
	7+		2x10 ¹¹	10 ¹⁰
Ar	3+	2x10 ¹⁵		
	8+	4x10 ¹²	2x10 ¹³	10 ¹⁰
	12+		2x10 ¹¹	8x10 ⁹
	18+			6x10 ⁹
Norm. Emit. ϵ_n (π mm mrad)		.1-1	.1-1	.1

PIG data for 15 hour average from BEX [11].

ECR data from Geller [12]

EBIS intensities are calculated as $10^{11}/Q$, and its repetition rate could be $1-10^3$ Hz, depending on confinement time required for the charge state.

The development of PIG sources is continuing in many laboratories to improve intensity, lifetime and the range of ion species. The charge state distribution is not likely to change much because of the limits of confinement time given by the drift time to the cathodes, and the electron current density which is determined by cathode emission.

3.2. Duoplasmatron Sources.

The duoplasmatron was originally a source for protons, and was later developed for high charge state heavy ions at the UNILAC heavy ion accelerator at GSI, Darmstadt [13]. It was found that the output of Xe^{5+} ..11⁺ was greatly increased by placing the position of the maximum magnetic field at the anode aperture instead of between anode and intermediate electrode. Also the anode shield was directly water cooled. Reducing the diameter of the intermediate electrode aperture increased the voltage, which gives higher charge states. Extraction was at 20-50 kV. Solid materials can be fed into the source by an oven. The duoplasmatron has longer life and better emittance than the PIG. However the PIG has higher output of high charge states for the heaviest ions, and has a

simple sputtering electrode system for solid material feed, so it is now the standard source at GSI.

3.3 Electron Cyclotron Resonance (ECR) Sources

The ECR source contains a hot electron plasma, formed when the electrons are accelerated by microwave power at the resonant cyclotron frequency in the confining magnetic field, Fig. 7. Plasma of the desired species is produced in the small first stage by feeding in gas and microwave power. The pressure here is 10^{-3} torr, a typical value for many ion sources. The charge state at this point is approximately the same as in a PIG source: 2^+-3^+ for heavy ions. An axial magnetic field of several kilogauss guides the plasma to the second stage. Here the stripping to high charge states is done by the energetic electrons of up to 20 keV created by a second microwave resonance. The background pressure in this second stage must be low, 10^{-6} - 10^{-7} torr, to prevent charge exchange by the high charge state ions that are created. For a long confinement time of the ions against plasma instabilities, a sextupole magnetic field is superimposed on the basic mirror configuration of the second stage, in a minimum B configuration. The beam is extracted from the source at 10-20 kV. The duty factor can be 100%, and life-time is 1000's of hours, since there are no sputtered cathodes to replace. The first ECR source producing beams of high intensity, high charge state ions was the SuperMAFIOS source developed by Geller at Grenoble, using an older plasma device [15]. It demonstrated that the ECR source could produce higher charge states than the PIG. Its disadvantage was that it required 3 MW of magnet power.

The next ECR source to be built was the MicroMAFIOS at Grenoble, Fig. 7 [14]. It uses several simplifications to save cost. It is compact in size, uses small bore room temperature solenoid magnets, samarium cobalt permanent magnets for the sextupole and 10 GHz for both microwave frequencies. The total power is about 100 kW, with 2 kW of rf power. Duty factor is 100%. Its high charge state ion beam currents are similar to those of SuperMAFIOS. The spectrum of charge states of 180 from MicroMAFIOS is shown in Fig. 8. The latest version of ECR source developed by Geller is called MiniMAFIOS [12]. It is a simplified version of MicroMAFIOS in which microwave power is fed only into the second stage,

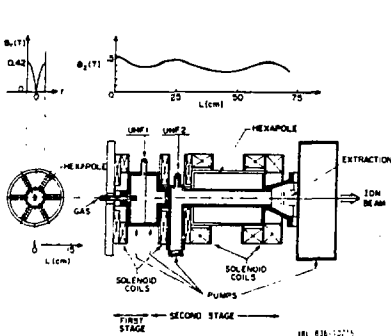

Fig. 7. The MicroMAFIOS ECR source built at Grenoble [14].



Fig. 8. 180 spectrum obtained from the MicroMAFIOS ECR source with an analyzing magnet [14].

with enough leakage into the first stage for plasma formation. The ion output for several ion species is shown in Table 1. Recent tests have demonstrated the production of many beams from solid materials introduced by a probe into the plasma [16]. European laboratories at Grenoble, Groningen and GANIL have ordered these compact sources for injection into cyclotrons.

Other groups have ECR source projects. A group at Moscow has built a simple source called HELIOS with a 12 cm long plasma and magnetic mirror field formed by permanent magnets [17]. Microwave power at 2.4 GHz is only 100 watts. Beam is extracted radially by a "pusher" in the plasma at +10 kV, eliminating the need to have the plasma chamber at high voltage. The charge state distribution is similar to that of MicroMAFIOS. Groups at Oak Ridge and Berkeley are building sources similar to MicroMAFIOS [5]. A group at Osaka University has extracted high charge state ions from a single stage ECR plasma [18]. This group has also demonstrated heating of an ECR plasma by injection of fast electrons [19].

To penetrate the plasma, the microwave frequency has to be greater than the cut-off frequency, which is proportional to the square root of plasma density. This limits plasma density. To obtain higher density several groups have designed superconducting magnets to reach high magnetic field, corresponding to higher resonant microwave frequencies. The Karlsruhe cyclotron group is now operating the HISKA source, which uses superconducting mirror coils and a permanent magnet sextupole [5]. The Louvain-la-Neuve group is using the ECREVIS on the cyclotron injection system for experiments [5]. It has superconducting solenoid and sextupole coils. Its construction is shown in Fig. 9. A similar source is being built at the Jülich cyclotron laboratory, using higher microwave frequencies of up to 28 GHz in the first stage and 18 GHz in the second stage [5].

Several groups have worked on the theory of high charge state production in ECR plasmas, including Grenoble [20], Louvain-la-Neuve [21] and Livermore [22]. Further theoretical and experimental work is needed to understand the dependence of high charge state production on microwave frequency and source dimensions. Future work with the superconducting sources will provide some of this important information.

3.4 Electron Beam Ion Source (EBIS)

EBIS development is underway at several laboratories. The progress in the field was summarized in a workshop at Saclay-Orsay in 1981 [3]. The

principle is illustrated in Fig. 10. An electron gun launches a small diameter electron beam down the axis of a magnetic solenoid about 1 m long. The beam stops on the electron collector. The potential along the axis is defined by a number of hollow cylindrical drift tubes. The ions are contained radially in the electrostatic potential well of the electron beam, and axially by positive potential barriers on the end drift tubes as shown in the potential distribution. During a short "injection" period, the desired number of ions is accumulated in the well. Then the potential distribution is switched to the "ionization" mode, in which the first barrier is moved downstream to prevent additional low charge state ions from entering the potential well. The ions reach progressively higher charge states as the containment continues. When the average charge state has reached the desired value, the potential distribution is switched to the "extraction" mode. This applies a ramp voltage on the drift tubes, accelerating the ions out of the source into the extractor. The system thus uses a batch type process in which the intensity is determined by the number of ions per pulse and the number of pulses per second. For source

parameters of 10 keV, 1 A electron beam and 1 m length, the number of ions is $10^{11}/q$ where q is the average charge state.

The charge state distribution from the Dubna KRION source is shown in Fig. 11. Ions with charge states up to Ar^{18+} , Kr^{34+} and Xe^{48+} were obtained. More recently xenon charge states up to Xe^{52+} were seen, using an electron beam of 20 keV and $j_e = 1.5 \times 10^{22} \text{ cm}^{-2}$ [25]. To obtain higher electron beam densities some groups have designed external high compression guns, using electrostatic and magnetic compression.

Other groups working on EBIS sources include the Saclay group which is developing the CRYEBIS source to inject the Saturne synchrotron with the lighter heavy ions [26]. The Orsay group is developing CRYEBIS 2, designed for a 50 keV, 3.5 A electron beam in a superconducting solenoid of 5 T and 1.6 m length, with a high compression electron gun to produce 10^4 A cm^{-2} [27]. The ion goals include Xe^{54+} and U^{90+} with 10^9 ions per second. The Orsay group is also developing electron beam deceleration and laser vaporization injection at the room temperature EBIS called SILFEC III. The Frankfurt EBIS program has the goal of understanding basic EBIS properties and testing new principles as well as using the beam for atomic physics [28]. It uses a superconducting solenoid of 1 m length at 5 T and has produced ion beams. Areas of study include the oscillating electron mode of operation and the time-of-flight mode in which no containment is used. At Nagoya University the NICE-1 source is used for atomic physics [29]. It has a superconducting magnet of 2 T field and 1 m length. Ions such as C^{6+} , N^{7+} and O^{8+} have been produced.

At Giessen a room temperature EBIS is in use for atomic physics [30]. It uses the time-of-flight mode with no axial containment, to give continuous beams, and makes charge states up to Xe^{10+} . Cornell has built a room temperature EBIS using a distributed ion pump in the bore [31]. It has produced carbon, nitrogen and oxygen ions and will be used for atomic physics. At Berkeley a test room temperature EBIS was built to understand the physics and some of the technical problems of this type of source [32]. This program used a system of iron rings to define the magnetic field precisely along the axis. High charge state ions were obtained from the source.

The EBIS source is well suited to applications needing very high charge states or where a low duty factor is adequate. The estimated output of high charge states is listed in Table 1. The average current will be determined by the repetition rate. If collapse of the electron

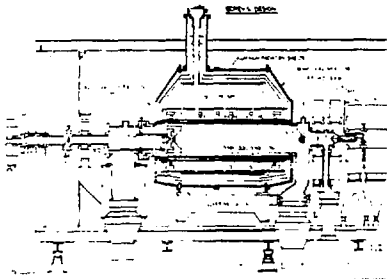

Fig. 9. The ECREVIS superconducting ECR source built by the Louvain-la-Neuve cyclotron group. (Courtesy Y. Jongen).

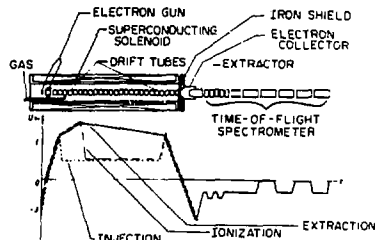

Fig. 10. Schematic drawing of the KRION ion source of the EBIS type, developed at Dubna [23].

beam due to space charge neutralization can be obtained, then shorter ionization time, higher repetition rate and higher average currents are possible. Some evidence of this collapse was reported by Orsay in 1979 [33]. The maximum charge state is limited only by the electron beam energy. $U92^{+}$ could be made with an electron energy of over 130 kV. The physics of the EBIS source was summarized by Vella [34].

3.5 Short Pulse Sources

There are several types of fast discharge devices which produce highly charged ions, but which are not usually equipped with extraction systems to form beams. These include the traditional sources used for atomic spectroscopy such as the vacuum arc and exploding wire. More recently high power laser beams hitting targets have formed high temperature plasmas which generate highly charged ions. These plasmas can have plasma temperatures of several keV to several hundred keV. Also fusion experiments such as Tokamaks have high temperature plasmas which can ionize vaporized chamber wall atoms to high charge states. These high charge state sources were reviewed recently [35], [36]. Charge states

produced are shown on Fig. 5. These short pulse length high power discharges are not suitable for many ion beam applications because of their low duty factor and their high instantaneous beam current handling requirements, but in a few cases beams have been formed, and higher duty factor may be possible with future development. We review briefly the devices and their resulting charge states.

The vacuum arc has been used for many years by atomic spectroscopists as a source of spectral lines of a multitude of ion charge states. The apparatus used at the Naval Research Laboratory is shown in Fig. 12. A short trigger pulse causes a 15 μ F, 14 kV capacitor to discharge with 100 kA peak current across the cathode-anode gap in a few microseconds. The source of X-rays is shown to be as small as .015 mm diameter. Charge states up to $Ar15^{+}$, $Fe25^{+}$ and $Mo40^{+}$ have been observed in vacuum arcs.

Another type of short pulse source used for spectroscopy is the exploding wire, which evolved from the vacuum arc. An experiment of this

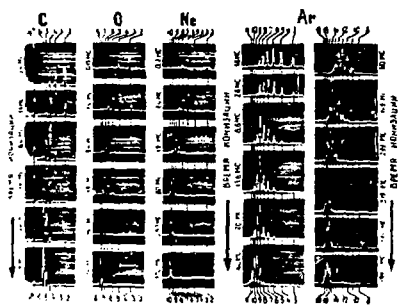

FIG. 936-12216

Fig. 11. Experimental data obtained with KRION-2 source at Dubna. Charge distributions from time-of-flight analyzer are shown for several ionization times (ms) for each element [24].

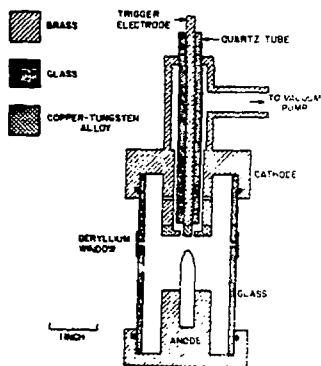

FIG. 936-12217

Fig. 12. Apparatus used by the Naval Research Laboratory, Wash. D.C. for vacuum arc spectroscopy [37].

type is shown in Fig. 13. Here a capacitor is discharged through thin wires or ribbons (.01-.1mm) stretched across the gap of a vacuum diode. the wire vaporizes and a 50 kJ high current plasma discharge pinches down to a size of <.03 to .08 mm, with pulse lengths of 80 nsec. High charge states up to Fe^{25+} , Mo^{33+} , W^{46+} and Au^{51+} have been identified by their spectral lines in exploding wire discharges.

A high power laser beam hitting a solid material produces a high density energetic plasma where high charge states are created. In recent years higher powers have been developed for fusion and military

applications. This field was reviewed by Tonon [39]. Several groups have extracted high charge state ions and formed beams for experiments. An example is the use of a CO_2 laser at Oak Ridge for atomic physics experiments, Fig. 14., A 3J laser can be focused on a target with a power density of $3 \times 10^{10} \text{ W/cm}^2$. Low energy carbon and oxygen ions of 10-700 eV/amu are available at charge states up to C^{6+} and O^{7+} . At higher power density, higher charge states are produced, since plasma temperature increases. Fig. 15 shows the range of cobalt charge state up to Co^{23+} and the correlation of energy with charge state for a laser flux of 10^{13} W/cm^2 . Charge states as high as Fe^{23+} and W^{55+} have been reported by the Lebedev Institute using a Nd glass laser at a power of $5 \times 10^{14} \text{ W/cm}^2$. More recently Los Alamos has used a 700 J/beam CO_2 laser to give power densities of 10^{16} W/cm^2 , producing hot electrons of 200 keV temperature [41]. Even higher charge states are expected in this case.

3.6 Charge Increase by Stripping

As we mentioned in Section 2., highly charged ions can be produced either by bombarding slow ions by fast electrons in a source, or by passing fast ions through a stripper material. The phenomenon of fast ion stripping has been investigated extensively for its intrinsic atomic physics interest and its use in the field of beam foil spectroscopy. Studies also provide vital practical data on beam attenuation in accelerators and charge increase in two stage accelerating systems. The field has been reviewed by Betz [42].

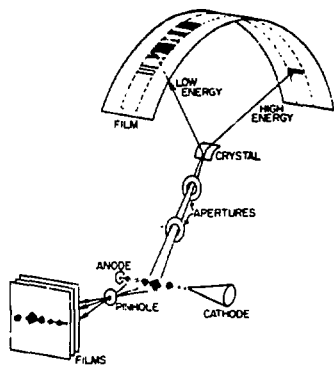

Fig. 13. Experimental arrangement for recording exploding wire data with an X-ray pinhole camera and crystal spectrograph used by the Naval Research Laboratory, Wash. D.C. [38].

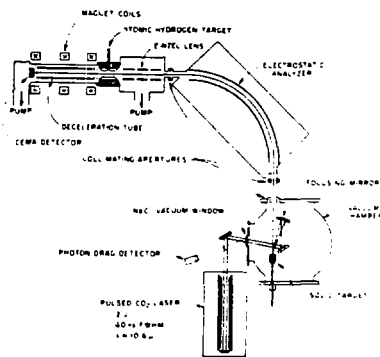

Fig. 14. Laser ion source and atomic physics apparatus used at Oak Ridge National Laboratory [40].

With each successive increase in energy of heavy ion accelerators, the charge states available from stripping their beams have increased. The recent upgrade of the Berkeley Bevalac heavy ion linear accelerator-synchrotron system has made possible the acceleration of all elements up to uranium to energies that produce fully stripped ions in a stripper, Fig. 5. In Fig. 16 are shown the charge state distributions of Bevalac uranium beams from several solid strippers. Fully stripped uranium, U^{92+} , is seen in all the distributions.

During studies of ion-beam fusion the question has arisen of the effectiveness of a plasma for stripping and stopping an ion beam. Higher energy plasmas increase the charge state of a projectile, causing shorter stopping range. Calculations of this effect have been done at the Weizmann Institute and some results are shown in Fig. 17. The reason given for the high effective Z in the highly ionized targets is the lower cross-section for re-combination with free electrons. The calculation indicates that a plasma stripper would be even more effective than a solid for ions in the energy range of <1 MeV/amu.

3.7 Recoil Ions

The final method of high charge state ion production to be discussed is that of recoil target ions produced by fast ion beams hitting a target. In this case the recoil ions are normally of lower charge state

than that of the incoming beam, but they have the virtue of having low velocities so that they can be used for low energy atomic physics experiments. An example of this type of experiment is shown in Fig. 18. Here a 19 MeV F^{4+} beam produces $Ar^{1...10+}$ recoils, which are accelerated with a voltage of 200-700 volts, and used for electron capture measurements on gas targets. In another experiment at GSI a beam of 1.4 MeV/amu U^{44+} ions produces recoil atoms on a gas target with charge states up to Ne^{8+} , Ar^{10+} , Kr^{12+} and Xe^{18+} [46].

4. Conclusions

We have seen that the ECR and EBIS high charge state ion sources are finding widespread use in accelerator and atomic physics applications. We can look forward to continued development of these sources in the areas of

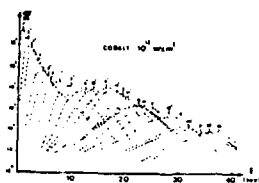

© 1972 IEEE

Fig. 15. Energy distribution of cobalt charge states with 10^{13} W/cm² laser flux at the Moscow Engineering Physics Institute [39].

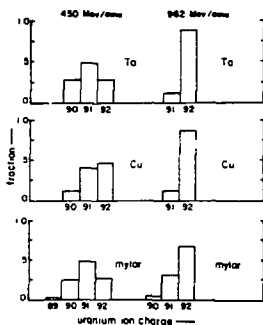

LBL 825-8640

Fig. 16. Equilibrium charge state distributions of uranium at two energies in three solid stripper materials at Berkeley Bevalac [43].

higher frequency ECR sources, and higher charge state and repetition rate in EBIS sources. Higher power lasers will make higher charge states available. The production of ions by stripping has reached fully stripped uranium, and a plasma stripper has potential for more efficient stripping at low energies. The use of slow recoil atoms from targets has become important recently in atomic physics.

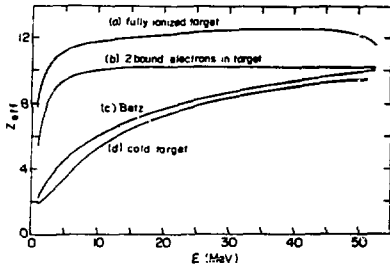

LBL 836-13274

Fig. 17. Calculated charge state Z_{eff} of an aluminum ion as it is slowed in carbon targets having various temperatures [44].

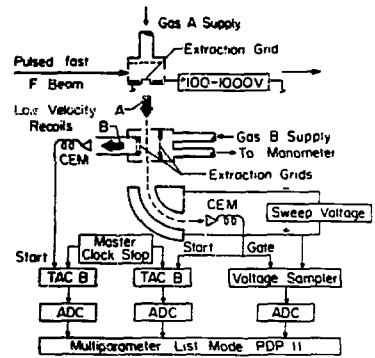

LBL 836-11

Fig. 18. Experiment at Kansas State University using the recoil ions from a gas target hit by fast beam [45].

5. Acknowledgements.

The author wishes to thank the many people who supplied information for this paper. These include N. Angert, T. Antaya, J. Arianer, J. Conway, B. Feinberg, P. Goldstone, H. Gould, Y. Jongen, Y. Kaneko, H. Klein, D. Matthews, R. McCrory, K. Oda, M. Richardson, F. Schlachter and K. Toyoda.

6. References

1. IEEE Trans. Nucl. Sci. NS-19, 2 (1972)
2. IEEE Trans. Nucl. Sci. NS-23, 2 (1976)
3. II EBIS Workshop, Laboratoire National Saturne II - Saclay (CEA-IN2P3) and Institut de Physique Nucleaire - Orsay (IN2P3), Saclay-Orsay, France, May 12-15, 1981.
4. Physica Scripta T3 (1983).
5. 5th E.C.R. Ion Sources Workshop Proceedings, Laboratoire du Cyclotron, Universite Catholique de Louvain, Louvain-la-Neuve, Belgium, April 21-22, 1983.
6. M. Olivier, Proc. Workshop on Accelerator Systems for Relativistic Heavy Ions in Medical and Scientific Research, Edmonton (1980), p. 337.
7. O.J. Nagel, Beam Foil Spectroscopy, Vol. 2, p. 961, Ed. I Sellin and D. Pegg, Plenum Press (1976).
8. V.S. Nikolaev and I. S. Dimitriev, Phys. Lett. 28A, 277 (1968).
9. J. R. J. Bennett, Ref. 1, p. 48.

10. T. S. Green, Proc. 2nd Symp. on Ion Sources and Formation of Ion Beams, Berkeley, CA, LBL-3399, I-2, Lawrence Berkeley Laboratory (1974).
11. L. Bex and G. Cardin, GANIL 80R/153/IS/09, GANIL Laboratory (1980).
12. R. Geller and B. Jacquot, Ref. 4, p. 19.
13. R. Keller and M. Muller, Ref. 2, p. 1049; GSI-PB-2-75 (1975) Darmstadt.
14. S. Dousson, R. Geller and B. Jacquot, Proc. 2nd Int'l Conf. on Low Energy Ion Beams, Bath, U.K. (1980).
15. R. Geller, IEEE Trans. Nucl. Sci. NS-26, 2, 2120 (1979).
16. R. Geller and B. Jacquot, Ref. 5.
17. V. D. Dugar-Zhabon, K. S. Golovanivsky and S. A. Safanov, Ref. 5.
18. Keiji Oda, Nobuyuki Abe, Takayoshi Yamamoto and Masaharu Kawanishi, Jap. J. Appl. Phys. 20, 955 (1981).
19. Keiji Oda, Yusuke Moriguchi, Takayoshi Yamamoto and Masaharu Kawanishi, Proc. 6th Symp. on Ion Sources and Ion-Assisted Technology, Tokyo (1982).
20. S. Bliman and N. Chantung, J. Plasma Phys. (Aug. 1979).
21. Y. Jongen, Rept. LC-8001, Laboratoire du Cyclotron, Université Catholique de Louvain (1980).
22. H. West, private communication.
23. E. D. Donets, Ref. 2 p. 897.
24. E. D. Donets and V. P. Ovsyannikov, Dubna Rept. P7-80-515 (1980).
25. E. D. Donets, Ref. 4, p. 11.
26. M. Olivier, J. Faure, J. L. Laclare, J. M. Lefebvre, G. Leleux, A. Ropert, A. Tkatchenko and M. Tkatchenko, IEEE Trans. Nucl. Sci. NS-30, 1463 (1983).
27. J. Arianer, C. Collart, Ch. Goldstein, H. Laurent and M. Malard, Ref. 4, p. 35.
28. R. Becker, M. Kleinod and H. Klein, Ref. 3, p. 48.
29. T. Iwai, Y. Kaneko, M. Kimura, N. Kobayashi, S. Ohtani, K. Okuno, S. Takagi, H. Tawara and S. Tsurubuchi, Phys. Rev. A26, 1, 105 (1982).
30. G. Clausnitzer, H. Klinger, A. Muller and E. Salzborn, Nucl. Instr. Meth. 128, 1 (1975).
31. V. O. Kostroun, E. Ghanbari, E. M. Beebe and S. W. Janson, Ref. 4, p. 47.
32. B. Feinberg and I. G. Brown, Ref. 3, p. 1; I. Brown and B. Feinberg, Ref. 3, p. 212.
33. J. Arianer, A. Cabrespine and C. Goldstein, IEEE Trans. Nucl. Sci. NS-26, 3 (1979) 3713.
34. M. C. Vella, Nucl. Instr. Meth. 187, 313 (1981).
35. Indrek Martinson, Phys. Scr. 23, 126 (1981).
36. B. C. Fawcett, Phys. Scr. 24, 663 (1981).
37. T. N. Lie and R. C. Elton, Phys. Rev. A3, 865 (1971).
38. P. G. Burkhalter, C. M. Dozier and D. J. Nagel, Phys. Rev. A15, 700 (1977).
39. G. F. Tonon, Ref. 1, p. 172.
40. R. A. Phaneuf and D. H. Crandall, Ref. 4, p. 131.
41. M. A. Yates, D. B. van Hulsteyn, H. Rutkowski, G. Kyrala and J. U. Brackbill, Phys. Rev. Lett. 49, 1702 (1982).
42. H. Betz, Meth. Exp. Phys. 17. (1980), Ed. L. Marton and C. Marton.
43. Henry Crawford, Harvey Goulu, Douglas Greiner, Peter Lindstrom and James Symons, Proc. 6th High Energy Heavy Ion Study and 2nd Workshop on Anomalons, Lawrence Berkeley Laboratory, June, 1983.
44. E. Nardi and Z. Zinamon, Phys. Rev. Lett. 49, 1251 (1982).
45. C. L. Cocke, R. DuBois, T. J. Gray, E. Justiniano and C. Can, Phys. Rev. Lett. 46, 1571 (1981).
46. A. S. Schlachter, W. Groh, A. Muller, H. F. Beyer, R. Mann and R. E. Olson, Phys. Rev. A26, 1373 (1982).

This report was done with support from the Department of Energy. Any conclusions or opinions expressed in this report represent solely those of the author(s) and not necessarily those of The Regents of the University of California, the Lawrence Berkeley Laboratory or the Department of Energy.

Reference to a company or product name does not imply approval or recommendation of the product by the University of California or the U.S. Department of Energy to the exclusion of others that may be suitable.