

HIFIMAN Hymalaya Pro

Ultra Low-Power High-performance 24-Bit, 768 kHz Digital-To-Analog Converter

Features:

- Minimized R-2R ladder DAC
- 24 bit Resolution
- 26.7 mw power consumption
- FS support 44.1 kHz to 768 kHz
- Input format compatible with IIS (Integrated Interface of-Sound)
- No external controlling ports needed.
- Voltage signal output
- Analog power supply is +3.3 V or +1.8 V / digital power :+1.2 V
- SNR > 120 dB
- THD+n < 0.0012 %
- 20 leads package

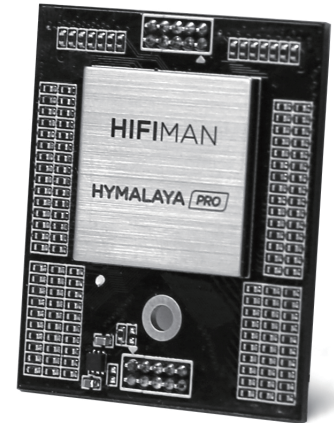

Description:

The Hymalaya Pro is an improved version of the original Hymalaya, it's an integrated circuit that includes 24 bit resolution stereo digital-to-analogue converters and support circuitry. The unique R-2R DAC architecture achieves excellent dynamic performance with improved tolerance to clock jitter and avoids most negative effects of "Up" or "Over" sampling.

The on-chip resistor network is a high-precision chip resistor with low temperature drift, which ensures stable performance from -3 °C to +105 °C.

Due to the design of Hymalaya Pro as a voltage output, there are no external filters to obtain analogue signals, which simplifies the design process. In terms of module usage, it can be designed as a differential connection method with a single channel, which offers greater convenience for designers allowing them to separate the power supply or even split analogue and ground to achieve enhanced performance.

Construction:

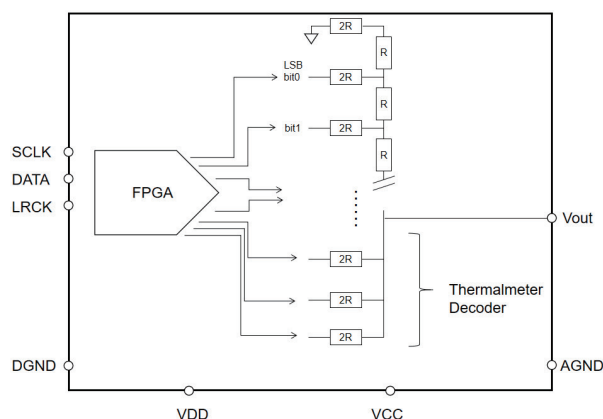

ELECTRICAL CHARACTERISTICS:

all specifications at Ta = 25 °C, VCC = +3.3 V, VDD =1.2 V fS = 44.1 kHz to 192 KHz@24 bit

Index	Test conditions	Parameter			Units
		Min	Typical	Max	
Resolution			24		Bits
Input format			IIS		
Serial Clock		2.1168		36.864	MHz
Digital input voltage					
High			2.0	VDD	V(p- p)
Low		0.8			
Dynamic Performance					
THD+N, VO=0dB	Full Scale	<0.0012	0.0015	0.002	%
VO=-20dB			0.01		%
SNR		118	120	>120	
Dynamic Performance (open-loop)		115	120	>120	dB
Channel Separation			131		dB
DC feature					
DC drifting			1.65 ± 0.08		V
Analog Output feature					
Maximum output voltage			3		vP-P
Maximum output current			0.5		ma
Settling Time	THD+N0.003%		156		ns
Output impedance			5.9		Kff
Power supply					
VCC	25 °C	1.8	3.3	3.5	VDC
ICC			7		mA
VDD			1.2		VDC
IDD			3		mA
Total power consumption			26.7		mW
Temperature feature					
Storage temp		-5	25	85	°C
Soldering temp		220	260	330	°C

PIN ASSIGNMENTS:

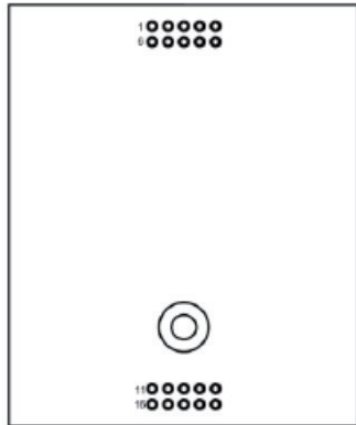

- 1-Reserved. Connect to ground
- 2-I²S Select pull high
- 3-NC. Connect to ground
- 4-RESET. Low to enter reset status
- 5-Power supply, +5VDC
- 6-Serial clock input
- 7-Bit clock input
- 8-Data input
- 9-Left Right / Word clock input
- 10-Digital ground
- 11-Left channel Positive output
- 12-Left channel Negative output
- 13-Analog ground
- 14-Right channel Positive output
- 15-Right channel Negative output
- 16-Analog ground
- 17-NC. Connect to ground
- 18-NC. Connect to ground
- 19-NC. Connect to ground
- 20-Analog ground

Data Timing :

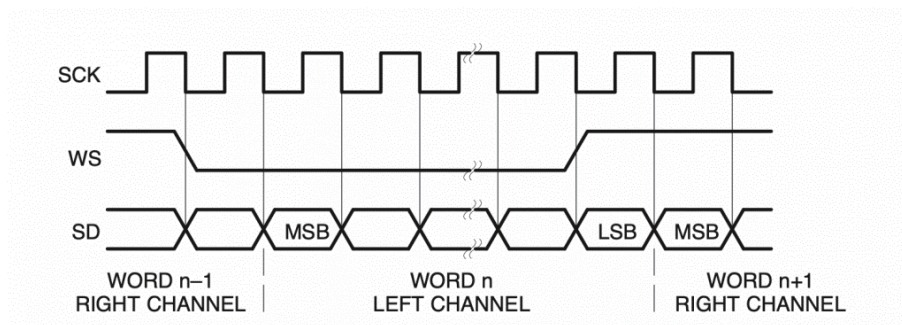

Dimensions(mm):

