



EPSON ESC/P

Reference Manual

December 1997

All rights reserved. No part of this publication may be reproduced, stored in a retrieval system, or transmitted in any form or by any means, electronic, mechanical, photocopying, recording, or otherwise, without the prior written permission of SEIKO EPSON Corporation. No patent liability is assumed with respect to the use of the information contained herein. While every precaution has been taken in the preparation of this book, SEIKO EPSON Corporation assumes no responsibility for errors or omissions. Neither is any liability assumed for damages resulting from the use of the information contained herein.

EPSON and EPSON ESC/P are registered trademarks and EPSON ESC/P 2 is a trademark of SEIKO EPSON Corporation.

ActionPrinter is a trademark of EPSON America, Inc.

Centronics is a trademark of Centronics Data Computer Corporation.

General Notice: Other product names used herein are for identification purposes only and may be trademarks of their respective owners. EPSON disclaims any and all rights in those marks.

Copyright © 1994-1997 by SEIKO EPSON Corporation, Nagano, Japan.

Contents

Introduction.....	1
About This Manual.....	2
Conventions Used in This Manual.....	2
Icons.....	2
Command names and parameters.....	3
Information organization.....	3
Nonrecommended and deleted commands.....	3
INT and MOD.....	4
Command Summary.....	C-1
Command List by Function.....	C-2
Command List by ASCII Order.....	C-6
Individual Command Explanations.....	C-9
Binary Mode Commands.....	C-216
Recommended Operations.....	R-1
Recommended Command Order.....	R-4
Set the Printing Area.....	R-5
The printable area.....	R-6
Setting left and right margins.....	R-9
Setting page length.....	R-10
Setting top and bottom margins.....	R-13
Setting bottom margin.....	R-13
Select Characters.....	R-15
Assign character tables.....	R-15
Defining user-defined characters.....	R-17
Selecting an international character set.....	R-41
Select a Font.....	R-42
Print quality (draft, LQ, or NLQ).....	R-43
Standard and scalable fonts (multipoint mode).....	R-43
Enhancements.....	R-51
Super/subscript.....	R-54
Select Supporting Features.....	R-55
Selecting unidirectional print head movement.....	R-55
Selecting print color.....	R-55
Select the Print Position.....	R-56
Moving the horizontal position.....	R-57
Moving the vertical position.....	R-60
Send Print Data.....	R-64
Sending Graphics Data.....	R-65
Extended raster graphics (ESC . 2).....	R-83
Printing Bar Codes.....	R-84
Extended ESC/P 2 Programming Guide.....	R-99
Programming examples.....	R-104

Command Table T-1

24/48-Pin Printers.....T-2
9-Pin PrintersT-22

Feature Summary F-1

24/48-Pin Printers.....F-3
9-Pin PrintersF-78

Appendix A-1

Character Tables A-2
Proportional Width Information..... A-21
 Proportional width during multipoint mode (ESC/P 2 only) A-21
 24/48-pin proportional width tables..... A-21
 9-pin proportional width tables A-26
ASCII Code Table A-30
Parallel Interface..... A-31
Internal Serial Interface A-35
 Six-pin DIN connector type..... A-35
 25-pin subminiature D-shell connector (female) type..... A-36
Optional Serial Interfaces..... A-37
Selecting PreESC/P 2 Fonts in ESC/P 2 Multipoint Mode..... A-38

Glossary G-1

Index I-1

Introduction

When EPSON created the ESC/P printer control language, the industry standard for simple, sophisticated, efficient operation of dot-matrix printers was born.

With the scalable fonts, high-resolution color raster graphics, and advanced page handling available with ESC/P 2, EPSON has narrowed the gap between dot-matrix and page printers. Features previously found only on laser printers are now available at affordable dot-matrix printer prices.

This manual was developed as an aid in creating programs and drivers that take advantage of all the latest features of EPSON's printers. It is assumed the reader understands basic concepts such as bytes, ASCII codes, commands, and parameters. It is also assumed the reader can use a programming language or application program to send commands to the printer. By following the recommendations within this manual, your programs will allow EPSON printers to perform at the optimum levels they were designed for.

With the introduction of our line of high-resolution color printers, we have expanded some existing ESC/P commands and added several new ones. This manual describes all ESC/P commands, including two new compressed raster graphics modes and MicroWeave, EPSON's revolutionary technology that virtually eliminates banding in graphics.

In addition, we have provided a list of features and options available on all dot-matrix printers produced by EPSON for the American, European, and non-Japanese Pacific markets.

About This Manual

This manual is composed of four main sections.

Command Summary	Contains a detailed description of all commands available in EPSON ESC/P, with new commands available in ESC/P 2 clearly identified. Also, the following information is included: <ul style="list-style-type: none">• Differences between 9-pin and 24/48-pin commands• Printers that do not feature particular commands• Differences in command functions among printers
Recommended Operations	Detailed explanations on how to use commands to perform specific functions in the most efficient manner.
Command Table	Tables that show the commands and command parameters featured on all EPSON printers.
Feature Summary	Features and options available on all EPSON printer models, as well as DIP-switch settings on applicable printers.

In addition, the Appendix contains information on character tables, widths of proportional characters, and interfaces.

A Glossary and Index also provide convenient reference information.

The information in this manual will be updated on a regular basis to continually provide the most current information on commands and printer models.

Conventions Used in This Manual

A number of conventions are used in this manual to aid in describing commands and distinguishing between ESC/P versions.

Icons

One or more of the following icons appear next to the command description, indicating availability to a particular printer type.

 Available on EPSON ESC/P 2 printers

 Available on EPSON 24 /48-pin printers featuring a previous ESC/P level

 Available on 9-pin printers

Command names and parameters

Command names are normally referred to in their ASCII code version. ESC (v and ESC C NUL are examples. You can find the decimal or hexadecimal values of the ASCII codes listed in the ASCII code table in the Appendix. The decimal and hexadecimal values are also listed for each command in the Command Summary section.

Command parameters are listed as variables or as decimal numbers in the text.

Information organization

Commands in the Command Summary and explanations in the Recommended Operations section are organized according to the order described in Recommended Command Order.

Commands in the Command Table are organized according to ASCII order. Printer models in the Command Table are organized by date of first manufacture, with the most recent models listed first.

Printer models in the Feature Summary are divided into 24/48-pin and 9-pin sections and listed alphabetically.

Non recommended and deleted commands

As dot-matrix printer technology has developed, EPSON has added new commands and parameters to ESC/P, and now ESC/P 2. Because of these additions, the functions of several older commands have been duplicated or have become obsolete.

Deleted commands have been deleted from ESC/P and are no longer featured on EPSON printers.

Nonrecommended commands are commands that are no longer necessary and will eventually be deleted, but remain temporarily in order to preserve compatibility with existing printer drivers. At some point, these commands will be deleted; do not use these commands in new printer programs.

INT and MOD

Some command parameters may exceed 256, and require two bytes of data. These variables are listed with the subscripts L for low and H for high (for example, n_L and n_H , or m_L and m_H).

To determine the value of these two bytes, this manual uses the INT and MOD conventions. INT indicates the integer (or whole number) part of a number, while MOD indicates the remainder of a division operation.

For example, to break the value 520 into two bytes, use the following two equations:

$$n_H = \text{INT}\left(\frac{520}{256}\right) \quad n_L = \text{MOD}\left(\frac{520}{256}\right)$$

INT simply deletes the fraction part of the number, and the value of n_H is calculated as shown below.

$$n_H = \text{INT}\left(2 \frac{8}{256}\right)$$

$$n_H = 2$$

MOD, on the other hand, results in the remainder of the division operation of the fraction part as shown below.

$$n_L = \text{MOD}\left(2 \frac{8}{256}\right)$$

$$n_L = 8$$

Command Summary

Command List by Function.....	C-2
Command List by ASCII Order.....	C-6
Individual Command Explanations.....	C-9
Binary Mode Commands.....	C-216

Command List by Function

The following section lists commands by their function. The shaded areas are discontinued or nonrecommended commands. For alternative command recommendations, see the command description.

Command names		ESC/P2	ESC/P	9-Pin ESC/P	Page
Setting the page format					
ESC (C	Set page length in defined unit	•	—	—	C-10
ESC (c	Set page format	•	—	—	C-11
ESC C	Set page length in lines	•	•	•	C-13
ESC C NUL	Set page length in inches	•	•	•	C-15
ESC N	Set bottom margin	•	•	•	C-17
ESC O	Cancel bottom margin	•	•	•	C-19
ESC Q	Set right margin	•	•	•	C-21
ESC I	Set left margin	•	•	•	C-23
Moving the print position					
CR	Carriage return	•	•	•	C-25
LF	Line feed	•	•	•	C-27
FF	Form feed	•	•	•	C-29
ESC \$	Set absolute horizontal print position	•	•	•	C-31
ESC \	Set relative horizontal print position	•	•	•	C-33
ESC (V	Set absolute vertical print position	•	—	—	C-37
ESC (v	Set relative vertical print position	•	—	—	C-39
ESC J	Advance print position vertically	•	•	•	C-41
HT	Tab horizontally	•	•	•	C-43
VT	Tab vertically	•	•	•	C-45
ESC f	Horizontal/vertical skip			•	C-47
BS	Backspace	•	•	•	C-48
Setting the units					
ESC (U	Set unit	•	—	—	C-50
ESC 0	Select 1/8-inch line spacing	•	•	•	C-51
ESC 2	Select 1/6-inch line spacing	•	•	•	C-53
ESC 3	Set n/180-inch line spacing	•	•	—	C-55
ESC 3	Set n/216-inch line spacing	—	—	•	C-56
ESC +	Set n/360-inch line spacing	•	•	—	C-57
ESC A	Set n/60-inch line spacing	•	•	—	C-58
ESC A	Set n/72-inch line spacing	—	—	•	C-59
ESC 1	Select 7/72-inch line spacing	—	—	•	C-60
ESC D	Set horizontal tabs	•	•	•	C-61
ESC B	Set vertical tabs	•	•	•	C-63
ESC b	Set vertical tabs in VFU channels	—	•	•	C-65
ESC /	Select vertical tab channel	—	•	•	C-67
ESC e	Set fixed tab increment	—	—	•	C-69

Command names		ESC/P2	ESC/P	9-Pin ESC/P	Page
ESC a	Select justification	—	•	•	C-71
Selecting characters					
ESC (t	Assign character table	•	—	•	C-73
ESC t	Select character table	•	•	•	C-77
ESC R	Select an international character set	•	•	•	C-80
ESC &	Define user-defined characters	•	•	•	C-84
ESC :	Copy ROM to RAM	•	•	•	C-89
ESC %	Select user-defined set	•	•	•	C-91
ESC x	Select LQ or draft	•	•	—	C-93
ESC x	Select NLQ or draft	—	—	•	C-94
ESC k	Select typeface	•	•	•	C-95
ESC X	Select font by pitch and point	•	—	—	C-97
ESC c	Set horizontal motion index (HMI)	•	—	—	C-99
ESC P	Select 10.5-point, 10-cpi	•	•	—	C-100
ESC P	Select 10-cpi	—	—	•	C-101
ESC M	Select 10.5-point, 12-cpi	•	•	—	C-102
ESC M	Select 12-cpi	—	—	•	C-103
ESC g	Select 10.5-point, 15-cpi	•	•	—	C-104
ESC g	Select 15-cpi	—	—	•	C-105
ESC p	Turn proportional mode on/off	•	•	•	C-106
ESC SP	Set intercharacter space	•	•	•	C-108
ESC E	Select bold font	•	•	•	C-110
ESC F	Cancel bold font	•	•	•	C-112
ESC 4	Select italic font	•	•	•	C-114
ESC 5	Cancel italic font	•	•	•	C-116
ESC !	Master select	•	•	•	C-118
ESC G	Select double-strike printing	•	•	•	C-121
ESC H	Cancel double-strike printing	•	•	•	C-123
ESC -	Turn underline on/off	•	•	•	C-125
ESC (-	Select line/score	•	•	—	C-127
ESC S	Select superscript/subscript printing	•	•	•	C-129
ESC T	Cancel superscript/subscript printing	•	•	•	C-131
ESC q	Select character style	•	•	—	C-133
SI	Select condensed printing	•	•	•	C-134
ESC SI	Select condensed printing	•	•	•	C-136
DC2	Cancel condensed printing	•	•	•	C-138
SO	Select double-width printing (one line)	•	•	•	C-140
ESC SO	Select double-width printing (one line)	•	•	•	C-142
DC4	Cancel double-width printing (one line)	•	•	•	C-144
ESC W	Turn double-width printing on/off	•	•	•	C-146
ESC w	Turn double-height printing on/off	•	•	•	C-148

Command names		ESC/P2	ESC/P	9-Pin ESC/P	Page
Control-code character printing					
ESC (^	Print data as characters	•	—	—	C-150
ESC 6	Enable printing of upper control codes	•	•	•	C-151
ESC 7	Enable upper control codes	•	•	•	C-153
ESC l	Enable printing of control codes	—	—	•	C-155
ESC m	Select printing of upper control codes	—	—	•	C-156
Mechanical control					
ESC EM	Control paper loading/ejecting	•	•	•	C-157
ESC U	Turn unidirectional mode on/off	•	•	•	C-159
ESC <	Unidirectional mode (one line)	•	•	•	C-161
BEL	Beeper	•	•	•	C-163
ESC 8	Disable paper-out detector	—	—	•	C-165
ESC 9	Enable paper-out detector	—	—	•	C-166
ESC s	Select low-speed mode	—	•	•	C-167
Printing color and graphics					
ESC (G	Select graphics mode	•	—	—	C-169
ESC (i	Select MicroWeave print mode	•	—	—	C-171
ESC .	Print raster graphics	•	—	—	C-172
ESC . 2	Enter TIFF compressed mode	•	—	—	C-175
ESC *	Select bit image	•	•	•	C-177
ESC ?	Reassign bit-image mode	•	•	•	C-181
ESC K	Select 60-dpi graphics	•	•	•	C-183
ESC L	Select 120-dpi graphics	•	•	•	C-185
ESC Y	Select 120-dpi, double-speed graphics	•	•	•	C-187
ESC Z	Select 240-dpi graphics	•	•	•	C-189
ESC ^	Select 60/120-dpi, 9-pin graphics	—	—	•	C-191
ESC r	Select printing color	•	•	•	C-193
Printing bar codes					
ESC (B	Bar code setup and print	•	•	•	C-195
Data and memory control					
ESC @	Initialize printer	•	•	•	C-198
CAN	Cancel line	•	•	•	C-200
DEL	Delete last character in buffer	•	•	•	C-202
DC1	Select printer	•	•	•	C-204
DC3	Deselect printer	•	•	•	C-206
ESC #	Cancel MSB control	•	•	•	C-208
ESC =	Set MSB to 0	•	•	•	C-210
ESC >	Set MSB to 1	•	•	•	C-212

Deleted commands

ESC j	Reverse paper feed	—	—	•	C-214
ESC i	Select immediate print mode	—	—	•	C-215

Binary mode commands for ESC . 2 raster graphics compression mode

<XFER>	Transfer raster graphics data	•	—	—	C-217
<MOVX>	Set relative horizontal position	•	—	—	C-218
<MOVY>	Set relative vertical position	•	—	—	C-219
<COLR>	Select printing color	•	—	—	C-220
<CR>	Carriage return to left-most print position	•	—	—	C-221
<EXIT>	Exit TIFF compressed mode	•	—	—	C-222
<MOVXBYTE>	Set <MOVX> unit to 8 dots	•	—	—	C-223
<MOVXDOT>	Set <MOVX> unit to 1 dot	•	—	—	C-224

Command List by ASCII Order

The following section lists commands by their ASCII order. The shaded areas are discontinued or nonrecommended commands. For alternative command recommendations, see the specific command description. For discontinued commands, see “Deleted commands” on page C-5.

	Command names	ESC/P2	ESC/P	9-Pin ESC/P	Page
BEL	Beeper	•	•	•	C-163
BS	Backspace	•	•	•	C-48
HT	Tab horizontally	•	•	•	C-43
LF	Line feed	•	•	•	C-27
VT	Tab vertically	•	•	•	C-45
FF	Form feed	•	•	•	C-29
CR	Carriage return	•	•	•	C-25
SO	Select double-width printing (one line)	•	•	•	C-140
SI	Select condensed printing	•	•	•	C-134
DC1	Select printer	•	•	•	C-204
DC2	Cancel condensed printing	•	•	•	C-138
DC3	Deselect printer	•	•	•	C-206
DC4	Cancel double-width printing (one line)	•	•	•	C-144
CAN	Cancel line	•	•	•	C-200
ESC SO	Select double-width printing (one line)	•	•	•	C-142
ESC SI	Select condensed printing	•	•	•	C-136
ESC EM	Control paper loading/ejecting	•	•	•	C-157
ESC SP	Set intercharacter space	•	•	•	C-108
ESC !	Master select	•	•	•	C-118
ESC #	Cancel MSB control	•	•	•	C-208
ESC \$	Set absolute horizontal print position	•	•	•	C-31
ESC %	Select user-defined set	•	•	•	C-91
ESC &	Define user-defined characters	•	•	•	C-84
ESC (-	Select line/score	•	•	—	C-127
ESC (B	Bar code setup and print	•	•	•	C-195
ESC (C	Set page length in defined unit	•	—	—	C-10
ESC (G	Select graphics mode	•	—	—	C-169
ESC (U	Set unit	•	—	—	C-50
ESC (V	Set absolute vertical print position	•	—	—	C-37
ESC (^	Print data as characters	•	—	—	C-150
ESC (c	Set page format	•	—	—	C-11
ESC (i	Select MicroWeave print mode	•	—	—	C-171
ESC (t	Assign character table	•	—	•	C-73
ESC (v	Set relative vertical print position	•	—	—	C-39
ESC *	Select bit image	•	•	•	C-177
ESC +	Set n/360-inch line spacing	•	•	—	C-57
ESC -	Turn underline on/off	•	•	•	C-125
ESC .	Print raster graphics	•	—	—	C-172
ESC . 2	Enter TIFF compressed mode	•	—	—	C-175

Command names		ESC/P2	ESC/P	9-Pin ESC/P	Page
ESC /	Select vertical tab channel	—	•	•	C-67
ESC 0	Select 1/8-inch line spacing	•	•	•	C-51
ESC 1	Select 7/72-inch line spacing	—	—	•	C-60
ESC 2	Select 1/6-inch line spacing	•	•	•	C-53
ESC 3	Set n/180-inch line spacing	•	•	—	C-55
ESC 3	Set n/216-inch line spacing	—	—	•	C-56
ESC 4	Select italic font	•	•	•	C-114
ESC 5	Cancel italic font	•	•	•	C-116
ESC 6	Enable printing of upper control codes	•	•	•	C-151
ESC 7	Enable upper control codes	•	•	•	C-153
ESC 8	Disable paper-out detector	—	—	•	C-165
ESC 9	Enable paper-out detector	—	—	•	C-166
ESC :	Copy ROM to RAM	•	•	•	C-89
ESC <	Unidirectional mode (one line)	•	•	•	C-161
ESC =	Set MSB to 0	•	•	•	C-210
ESC >	Set MSB to 1	•	•	•	C-212
ESC ?	Reassign bit-image mode	•	•	•	C-181
ESC @	Initialize printer	•	•	•	C-198
ESC A	Set n/60-inch line spacing	•	•	—	C-58
ESC A	Set n/72-inch line spacing	—	—	•	C-59
ESC B	Set vertical tabs	•	•	•	C-63
ESC C	Set page length in lines	•	•	•	C-13
ESC C NUL	Set page length in inches	•	•	•	C-15
ESC D	Set horizontal tabs	•	•	•	C-61
ESC E	Select bold font	•	•	•	C-110
ESC F	Cancel bold font	•	•	•	C-112
ESC G	Select double-strike printing	•	•	•	C-121
ESC H	Cancel double-strike printing	•	•	•	C-123
ESC I	Enable printing of control codes	—	—	•	C-155
ESC J	Advance print position vertically	•	•	•	C-41
ESC K	Select 60-dpi graphics	•	•	•	C-183
ESC L	Select 120-dpi graphics	•	•	•	C-185
ESC M	Select 10.5-point, 12-cpi	•	•	—	C-102
ESC M	Select 12-cpi	—	—	•	C-103
ESC N	Set bottom margin	•	•	•	C-17
ESC O	Cancel bottom margin	•	•	•	C-19
ESC P	Select 10.5-point, 10-cpi	•	•	—	C-100
ESC P	Select 10-cpi	—	—	•	C-101
ESC Q	Set right margin	•	•	•	C-21
ESC R	Select an international character set	•	•	•	C-80
ESC S	Select superscript/subscript printing	•	•	•	C-129
ESC T	Cancel superscript/subscript printing	•	•	•	C-131
ESC U	Turn unidirectional mode on/off	•	•	•	C-159
ESC W	Turn double-width printing on/off	•	•	•	C-146

Command names		ESC/P2	ESC/P	9-Pin ESC/P	Page
ESC X	Select font by pitch and point	•	—	—	C-97
ESC Y	Select 120-dpi, double-speed graphics	•	•	•	C-187
ESC Z	Select 240-dpi graphics	•	•	•	C-189
ESC \	Set relative horizontal print position	•	•	•	C-33
ESC ^	Select 60/120-dpi, 9-pin graphics	—	—	•	C-191
ESC a	Select justification	—	•	•	C-71
ESC b	Set vertical tabs in VFU channels	—	•	•	C-65
ESC c	Set horizontal motion index (HMI)	•	—	—	C-99
ESC e	Set fixed tab increment	—	—	•	C-69
ESC f	Horizontal/vertical skip	—	—	•	C-47
ESC g	Select 10.5-point, 15-cpi	•	•	—	C-104
ESC g	Select 15-cpi	—	—	•	C-105
ESC i	Select immediate print mode	—	—	•	C-215
ESC j	Reverse paper feed	—	—	•	C-214
ESC k	Select typeface	•	•	•	C-95
ESC l	Set left margin	•	•	•	C-23
ESC m	Select printing of upper control codes	—	—	•	C-156
ESC p	Turn proportional mode on/off	•	•	•	C-106
ESC q	Select character style	•	•	—	C-133
ESC r	Select printing color	•	•	•	C-193
ESC s	Select low-speed mode	—	•	•	C-167
ESC t	Select character table	•	•	•	C-77
ESC w	Turn double-height printing on/off	•	•	•	C-148
ESC x	Select LQ or draft	•	•	—	C-93
ESC x	Select NLQ or draft	—	—	•	C-94
DEL	Delete last character in buffer	•	•	•	C-202

Binary mode commands for ESC . 2

<XFER>	Transfer raster graphics data	•	—	—	C-217
<MOVX>	Set relative horizontal position	•	—	—	C-218
<MOVY>	Set relative vertical position	•	—	—	C-219
<COLR>	Select printing color	•	—	—	C-220
<CR>	Carriage return to left-most print position	•	—	—	C-221
<EXIT>	Exit TIFF compressed mode	•	—	—	C-222
<MOVXBYTE>	Set <MOVX> unit to 8 dots	•	—	—	C-223
<MOVXDOT>	Set <MOVX> unit to 1 dot	•	—	—	C-224

Individual Command Explanations

The following section describes the commands available in all ESC/P versions.

At the head of each command is the command title and one or more icons. The meaning of these icons is as follows:

ESC/P 2 The command explanation applies to 24/48-pin printers featuring ESC/P 2. “Function” explanations are based on ESC/P 2.

ESC/P The command explanation applies to 24/48-pin printers featuring previous ESC/P levels.

9-Pin ESC/P The command explanation applies to 9-pin printers.

If an ESC/P 2 command is also available in previous ESC/P levels, any differences in function are explained under the “Model-dependent variations” heading.

The explanations in these commands apply to the printers listed below:

ESC/P 2	ActionPrinter 3250 ActionPrinter 5000+ DLQ-3000 ('96 ~) LQ-300 LQ-670 LQ-1070+ LQ-2170 Stylus 800 Stylus COLOR	ActionPrinter 3260 ActionPrinter 5500 LQ-100 LQ-570 LQ-870 LQ-1170 Stylus 300 Stylus 800+ SQ-870	ActionPrinter 5000 DLQ-3000 LQ-150 LQ-570+ LQ-1070 LQ-2070 Stylus 400 Stylus 1000 SQ-1170
----------------	--	--	---

ESC/P	ActionPrinter 3000 ActionPrinter 4500 LQ-200 LQ-500 LQ-850 LQ-860+ LQ-1050 LQ-1060+ SQ-2550	ActionPrinter 4000 ActionPrinter L-1000 LQ-400 LQ-510 LQ-850+ LQ-950 LQ-1050+ LQ-2550 TLQ-4800	ActionPrinter L-750 DLQ-2000 LQ-450 LQ-550 LQ-860 LQ-1010 LQ-1060 SQ-850 TSQ-4800
--------------	---	--	---

9-Pin ESC/P	ActionPrinter T-750 ActionPrinter 2000 DFX-5000 FX-850 FX-1170 LX-300 LX-810 LX-1050+	ActionPrinter T-1000 ActionPrinter 2250 DFX-5000+ FX-870 FX-2170 LX-400 LX-850	ActionPrinter Apex 80 ActionPrinter 2500 DFX-8000 FX-1050 LX-100 LX-800 LX-1050
--------------------	--	--	---

Format

ASCII	ESC	(C	n _L	n _H	m _L	m _H
Hex	1B	28	43	n _L	n _H	m _L	m _H
Decimal	27	40	67	n _L	n _H	m _L	m _H

Parameter range

$$n_L = 2, n_H = 0$$

$$0 < ((m_H \times 256) + m_L) \times (\text{defined unit}) \leq 22$$

Function

Sets the page length in the specified number of units—previously defined with the ESC (U command—according to the following formula:

$$(\text{page length}) = ((m_H \times 256) + m_L) \times (\text{defined unit})$$

$$m_H = \text{INT} \left(\frac{(\text{page length}) \times \frac{1}{(\text{defined unit})}}{256} \right)$$

$$m_L = \text{MOD} \left(\frac{(\text{page length}) \times \frac{1}{(\text{defined unit})}}{256} \right)$$

Default

Depends on default-setting mode or DIP-switch setting

Notes

- This command is available only on printers featuring ESC/P 2.
- Set the page length before paper is loaded or when the print position is at the top-of-form position. Otherwise, the current print position becomes the top-of-form position (this results in undesirable contradictions between the actual and logical page settings).
- Setting the page length cancels the top and bottom-margin settings.
- Changing the defined unit does not affect the current page-length setting.

Printers not featuring this command

All non-ESC/P 2 printers

Model-dependent variations

None

Related topics

ESC (U, ESC (c, ESC C, FF, LF, ESC N, Set the Print Area, Setting page length

Format

ASCII	ESC	(c	n _L	n _H	t _L	t _H	b _L	b _H
Hex	1B	28	63	n _L	n _H	t _L	t _H	b _L	b _H
Decimal	27	40	99	n _L	n _H	t _L	t _H	b _L	b _H

Parameter range

$$n_L = 4, n_H = 0$$

$$((t_H \times 256) + t_L) < ((b_H \times 256) + b_L) \quad \text{top margin} < \text{bottom margin}$$

$$((b_H \times 256) + b_L) \times (\text{defined unit}) \leq 22 \quad \text{bottom margin} < 22 \text{ inches}$$

Function

Sets the top and bottom margins in the defined units—set with the ESC (U command—according to the following formulas:

$$(\text{top margin}) = ((t_H \times 256) + t_L) \times (\text{defined unit})$$

$$t_H = \text{INT} \left(\frac{(\text{top margin}) \times \frac{1}{(\text{defined unit})}}{256} \right)$$

$$t_L = \text{MOD} \left(\frac{(\text{top margin}) \times \frac{1}{(\text{defined unit})}}{256} \right)$$

$$(\text{bottom margin}) = ((b_H \times 256) + b_L) \times (\text{defined unit})$$

$$b_H = \text{INT} \left(\frac{(\text{bottom margin}) \times \frac{1}{(\text{defined unit})}}{256} \right)$$

$$b_L = \text{MOD} \left(\frac{(\text{bottom margin}) \times \frac{1}{(\text{defined unit})}}{256} \right)$$

Default

Continuous paper: None

Single-sheet paper: (top margin) = top-of-form position
(bottom margin) = last printable line

Notes

- This command is available only on printers featuring ESC/P 2.
- Measure both top and bottom margins from the top edge of the page.
- The baseline for printing characters on the first line is 20/180 inch below the top-margin position.
- Send this command before paper is loaded, or when paper is at the top-of-form position. Otherwise, the current print position becomes the top-margin position (this results in undesirable contradictions between the actual and logical page settings).
- This command cancels any previous top and bottom-margin settings.
- Changing the defined unit does not affect the current page-length setting.

Printers not featuring this command

All non-ESC/P 2 printers

Model-dependent variations

None

Related topics

ESC (U, ESC (C, ESC C, FF, LF, ESC (V, ESC (v, ESC N, Set the Printing Area, Setting top and bottom margins

Format

ASCII	ESC	C	n
Hex	1B	43	n
Decimal	27	67	n

Parameter range $1 \leq n \leq 127$ $0 < n \times (\text{current line spacing}) \leq 22 \text{ inches}$ **Function**

Sets the page length to n lines in the current line spacing

Default

Depends on default-setting mode or DIP-switch setting

Notes

- Set the page length before paper is loaded or when the print position is at the top-of-form position. Otherwise, the current print position becomes the top-of-form position.
- Setting the page length cancels the top and bottom margin settings.
- Changing the line spacing does not affect the current page-length setting.

Printers not featuring this command

None

Model-dependent variations

None

Related topics

ESC (C, ESC N, FF, LF, Set the Printing Area, Setting page length

Format

ASCII	ESC	C	n
Hex	1B	43	n
Decimal	27	67	n

Parameter range

$$1 \leq n \leq 127$$

$$0 < n \times (\text{current line spacing}) \leq 22 \text{ inches}$$

Function

Sets the page length to n lines in the current line spacing

Default

Depends on default-setting mode or DIP-switch setting

Notes

- Set the page length before paper is loaded or when the print position is at the top-of-form position. Otherwise, the current print position becomes the top-of-form position.
- Setting the page length cancels the bottom margin setting.
- Changing the line spacing does not affect the current page-length setting.

Printers not featuring this command

None

Model-dependent variations

None

Related topics

ESC N, FF, LF, Set the Printing Area, Setting page length

Format

ASCII	ESC	C	NUL	n
Hex	1B	43	00	n
Decimal	27	67	0	n

Parameter range

$$1 \leq n \leq 22$$

Function

Sets the page length to n inches

Default

Depends on default-setting mode or DIP-switch setting

Notes

- This command sets the page length in 1-inch increments only.
- Set the page length before paper is loaded or when the print position is at the top-of-form position. Otherwise, the current print position becomes the top-of-form position.
- Setting the page length cancels the top and bottom-margin settings.

Printers not featuring this command

None

Model-dependent variations

None

Related topics

ESC (C, ESC N, FF, LF, Set the Printing Area, Setting page length

Format

ASCII	ESC	C	NUL	n
Hex	1B	43	00	n
Decimal	27	67	0	n

Parameter range

$$1 \leq n \leq 22$$

Function

Sets the page length to n inches

Default

Depends on default-setting mode or DIP-switch setting

Notes

- This command sets the page length in 1-inch increments only.
- Set the page length before paper is loaded or when the print position is at the top-of-form position. Otherwise, the current print position becomes the top-of-form position.
- Setting the page length cancels the bottom-margin setting.

Printers not featuring this command

None

Model-dependent variations

None

Related topics

ESC N, FF, LF, Set the Printing Area, Setting page length

Format

ASCII	ESC	N	n
Hex	1B	4E	n
Decimal	27	78	n

Parameter range

$0 < n \leq 127$

$0 < (\text{current line spacing}) \times n < (\text{page length})$

Function

Sets the bottom margin on continuous paper to n lines (in the current line spacing) from the top-of-form position on the next page.

Default

Either no margin or 1-inch margin, depending on the DIP-switch setting

Notes

- The bottom margin set with the ESC N command is ignored when printing on single sheets.
- With ESC/P 2 printers, use the ESC (c command instead; this allows you to set both top and bottom margins on continuous and single-sheet paper.
- Sending this command cancels the top-margin setting.
- This was formerly called the “Set skip-over-perforation” command.

Printers not featuring this command

None

Model-dependent variations

None

Related topics

ESC (C, ESC (c, ESC C, FF, LF, Set the Printing Area, Setting bottom margin

Format

ASCII	ESC	N	n
Hex	1B	4E	n
Decimal	27	78	n

Parameter range

$0 < n \leq 127$

$0 < (\text{current line spacing}) \times n < (\text{page length})$

Function

Sets the bottom margin on continuous paper to n lines (in the current line spacing) from the top-of-form position on the next page

Default

Either no margin or 1-inch margin, depending on the default-setting mode or DIP-switch setting

Notes

- The bottom margin is ignored when printing on single sheets.
- This was formerly called the “Set skip-over-perforation” command.

Printers not featuring this command

None

Model-dependent variations

None

Related topics

ESC C, FF, LF, Set the Printing Area, Setting bottom margin

Format

ASCII	ESC	O
Hex	1B	4F
Decimal	27	79

Function

 Cancels the top and bottom margin settings

Notes

 This was formerly called the “Cancel skip-over-perforation” command.

Printers not featuring this command

 None

Model-dependent variations

 None

Related topics

 ESC N, ESC (C, ESC (c, ESC C, FF, LF, Set the Printing Area, Setting bottom margin

Format

ASCII	ESC	O
Hex	1B	4F
Decimal	27	79

Function

 Cancels the top and bottom margin settings

Notes

 This was formerly called the “Cancel skip-over-perforation” command.

Printers not featuring this command

 None

Model-dependent variations

 None

Related topics

 ESC N, ESC C, FF, LF, Set the Printing Area, Setting bottom margin

Format

ASCII	ESC	Q	n
Hex	1B	51	n
Decimal	27	81	n

Parameter range

$$1 \leq n \leq 255$$

$$(\text{left margin}) < (\text{current pitch}) \times n \leq (\text{printable area width})$$

Function

Sets the right margin to n columns in the current character pitch, as measured from the left-most printable column

Default

The right-most column

Notes

- Set the right margin at the beginning of a line; the printer ignores any data preceding this command on the same line in the buffer.
- The following commands affect character pitch: ESC P, ESC M, ESC g, ESC W, ESC p, ESC SP, SI, SO, ESC !, ESC X, and ESC c.
- The printer calculates the right margin based on 10 cpi if proportional spacing is selected with the ESC p command.
- Always set the pitch before setting the margins. Do not assume what the pitch setting will be.
- Always set the margins at the beginning of a print job.
- Always set the right margin to be at least one column (at 10 cpi) larger than the left.

Printers not featuring this command

None

Model-dependent variations

None

Related topics

ESC I, ESC \$, ESC \, HT, ESC D, Set the Printing Area, Setting left and right margins

Format

ASCII	ESC	Q	n
Hex	1B	51	n
Decimal	27	81	n

Parameter range

$1 \leq n \leq 255$
(left margin) < (current pitch) \times n \leq (printable area width)

Function

Sets the right margin to n columns in the current character pitch, as measured from the left-most printable column

Default

The right-most column

Notes

- Set the right margin at the beginning of a line; the printer ignores any data preceding this command on the same line in the buffer.
- The following commands affect character pitch: ESC P, ESC M, ESC g, ESC W, ESC p, ESC SP, SO, ESC !, and SI.
- The printer calculates the right margin based on 10 cpi if proportional spacing is selected with the ESC p command.
- Always set the pitch before setting the margins. Do not assume what the pitch setting will be.
- Always set the margins at the beginning of a print job.
- Always set the right margin to be at least two columns (at 10 cpi) greater than the left.

Printers not featuring this command

None

Model-dependent variations

None

Related topics

ESC I, ESC \$, ESC \, HT, ESC D, Set the Printing Area, Setting left and right margins

Format

ASCII	ESC	l	n
Hex	1B	6C	n
Decimal	27	108	n

Parameter range

$1 \leq n \leq 255$

$0 \leq (\text{left margin}) < (\text{right margin})$

80-column printers: $0 \leq (\text{left margin}) \leq 4.50$ inches

110-column printers: $0 \leq (\text{left margin}) \leq 7.00$ inches

136-column printers: $0 \leq (\text{left margin}) \leq 8.00$ inches

Function

Sets the left margin to n columns in the current character pitch, as measured from the left-most printable column

Defaultf

The left-most column (column 1)

Notes

- Set the left margin at the beginning of a line; the printer ignores any data preceding this command on the same line in the buffer.
- The following commands affect character pitch: ESC X, ESC c, ESC P, ESC M, ESC g, ESC W, ESC p, ESC SP, SO, ESC ! and SI.
- Always set the pitch before setting the margins. Do not assume what the pitch setting will be.
- Always set the margins at the beginning of a print job.
- Always set the left margin to be at least one column (at 10 cpi) less than the right.
- The printer calculates the left margin based on 10 cpi if proportional spacing is selected with the ESC p command.
- Moving the left-margin position moves the tab settings by the same distance.

Printers not featuring this command

None

Model-dependent variations

None

Related topics

ESC Q, ESC \$, ESC \, ESC D, HT, Set the Printing Area, Setting left and right margins

Format

ASCII	ESC	l	n
Hex	1B	6C	n
Decimal	27	108	n

Parameter range $1 \leq n \leq 255$ $0 \leq (\text{left margin}) < (\text{right margin})$ **Function**

Sets the left margin to n columns in the current character pitch, as measured from the left-most printable column

Default

The left-most column (column 1)

Notes

- Set the left margin at the beginning of a line; the printer ignores any data preceding this command on the same line in the buffer.
- The following commands affect character pitch: ESC P, ESC M, ESC g, ESC W, ESC p, ESC SP, and SI.
- The printer calculates the left margin based on 10 cpi if proportional spacing is selected with the ESC p command.
- Always set the pitch before setting the margins. Do not assume what the pitch setting will be.
- Always set the margins at the beginning of a print job.
- Always set the left margin to be at least two columns (at 10 cpi) less than the right.
- Moving the left margin position moves the tab settings by the same distance.

Printers not featuring this command

None

Model-dependent variations

None

Related topics

ESC Q, ESC \$, ESC \, ESC D, HT, Set the Printing Area, Setting left and right margins

Format

ASCII	CR
Hex	0D
Decimal	13

Function

Moves the print position to the left-margin position

Notes

- Always send a CR command at the end of each line of text or graphics data.
- When automatic line-feed is selected (through DIP-switch or panel setting), the CR command is accompanied by a LF command.

Printers not featuring this command

None

Model-dependent variations

On non-ESC/P 2 printers:

The printer prints all data in the line buffer after receiving a CR command.

Related topics

LF, ESC I, ESC SO, SO, ESC <, ESC ., <CR>, Recommended command order, Moving the horizontal position, Send print data

Format

ASCII	CR
Hex	0D
Decimal	13

Function

- Moves the print position to the left margin position
- Prints all data in the line buffer

Notes

- Always send a CR command at the end of each line of text or graphics data.
- When automatic line-feed is selected (through DIP-switch or panel setting), the CR command is accompanied by a LF command.

Printers not featuring this command

None

Model-dependent variations

None

Related topics

LF, ESC I, ESC SO, SO, ESC <, ESC ., Recommended command order, Moving the horizontal position, Send print data

Format

ASCII	LF
Hex	0A
Decimal	10

Function

- Advances the vertical print position one line (in the currently set line spacing)
- Moves the horizontal print position to the left-margin position

Notes

- You should always send a CR command before the LF command.
- The LF command cancels one-line double-width printing selected with the SO or ESC SO commands.
- If the LF command moves the print position below the bottom margin on continuous paper, the printer advances to the top-of-form position on the next page.
- If the LF command moves the print position below the bottom-margin position, or beyond the end of the printable area on single-sheet paper, the printer ejects the paper.

Printers not featuring this command

None

Model-dependent variations

On non-ESC/P 2 printers:

- Prints all data in the line buffer
- Advances paper to the top-of-form position on the next page if the LF command moves the print position below the bottom-margin position set with the ESC N command
- Ejects single-sheet paper if the LF command moves the print position beyond the end of the printable area

Related topics

FF, ESC I, ESC SO, SO, ESC <, ESC ., ESC C, ESC N, Recommended command order, Select the print position, Graphics mode, Moving the vertical position, Send print data

Format

ASCII	LF
Hex	0A
Decimal	10

Function

- Advances the vertical print position one line (in the currently set line spacing)
- Moves the horizontal print position to the left-margin position
- Prints all data in the buffer

Notes

- You should always send a CR command before the LF command.
- The LF command cancels one-line double-width printing selected with the SO or ESC SO commands.
- If the LF command moves the print position below the bottom margin on continuous paper, the printer advances to the top-of-form position on the next page.
- If the LF command moves the print position beyond the end of the printable area on single-sheet paper, the printer ejects the paper.

Printers not featuring this command

None

Model-dependent variations

None

Related topics

FF, ESC I, ESC SO, SO, ESC <, ESC ., ESC C, ESC N, Recommended command order, Select the print position, Graphics mode, Moving the vertical position, Send print data

Format

ASCII	FF
Hex	0C
Decimal	12

Function

- Advances the vertical print position on continuous paper to the top-margin position of the next page
- Ejects single-sheet paper
- Moves the horizontal print position to the left-margin position
- Prints all data in the buffer

Notes

- Always send a FF command at the end of each page and each print job.
- It is recommended to always send a CR command before the FF command.
- The FF command cancels one-line double-width printing selected with the SO or ESC SO commands.

Printers not featuring this command

None

Model-dependent variations

On non-ESC/P 2 printers:

Advances continuous paper to the current top-of-form position on the next page

Related topics

LF, ESC I, ESC SO, SO, ESC <, ESC., ESC C, ESC N, Recommended Command Order, Graphics mode, Moving the vertical position, Send Print Data

Format

ASCII	FF
Hex	0C
Decimal	12

Function

- Advances the vertical print position on continuous paper to the top-of-form position of the next page
- Ejects single-sheet paper
- Moves the horizontal print position to the left-margin position
- Prints all data in the buffer

Notes

- Always send a FF command at the end of each page and each print job.
- It is recommended to always send a CR command before the FF command.
- The FF command cancels one-line double-width printing selected with the SO or ESC SO commands.

Printers not featuring this command

None

Model-dependent variations

None

Related topics

LF, ESC I, SO, ESC <, ESC C, ESC N, Recommended Command Order, Graphics mode, Moving the vertical position, Send Print Data

Format

ASCII	ESC	\$	n _L	n _H
Hex	1B	24	n _L	n _H
Decimal	27	36	n _L	n _H

Parameter range

$$0 \leq n_H \leq 127$$

$$0 \leq n_L \leq 255$$

Function

Moves the horizontal print position to the position specified by the following formula:

$$(\text{horizontal position}) = ((n_H \times 256) + n_L) \times (\text{defined unit}) + (\text{left margin})$$

$$n_H = \text{INT} \left(\frac{((\text{horizontal position}) - (\text{left-margin position})) \times \frac{1}{(\text{defined unit})}}{256} \right)$$

$$n_L = \text{MOD} \left(\frac{((\text{horizontal position}) - (\text{left-margin position})) \times \frac{1}{(\text{defined unit})}}{256} \right)$$

Notes

- Set the defined unit with the ESC (U command.
- The default defined unit setting for this command is 1/60 inch.
- The new position is measured from the current left-margin position.
- The printer ignores this command if the specified position is to the right of the right margin.

Printers not featuring this command

None

Model-dependent variations

On non-ESC/P 2 printers:

The unit of movement is fixed at 1/60 inch.

Related topics

ESC \, ESC I, ESC Q, HT, CR, LF, FF, ESC (U, Moving the horizontal position

Format

ASCII	ESC	\$	n _L	n _H
Hex	1B	24	n _L	n _H
Decimal	27	36	n _L	n _H

Parameter range

$$0 \leq n_H \leq 127$$

$$0 \leq n_L \leq 255$$

Function

Moves the horizontal print position to the position specified by the following formula:

$$(\text{horizontal position}) = ((n_H \times 256) + n_L) \times (1/60 \text{ inch}) + (\text{left margin})$$

$$n_H = \text{INT} \left(\frac{((\text{horizontal position}) - (\text{left-margin position})) \times \frac{1}{(1/60 \text{ inch})}}{256} \right)$$

$$n_L = \text{MOD} \left(\frac{((\text{horizontal position}) - (\text{left-margin position})) \times \frac{1}{(1/60 \text{ inch})}}{256} \right)$$

Notes

- The new position is measured from the current left-margin position.
- The printer ignores this command if the specified position is to the right of the right margin.

Printers not featuring this command

ActionPrinter Apex 80, ActionPrinter T-1000, ActionPrinter 2000, ActionPrinter 2250, ActionPrinter 2500, LX-100, LX-300, LX-400, LX-800, LX-810, LX-850, LX-1050

Model-dependent variations

None

Related topics

ESC \, ESC I, ESC Q, HT, CR, LF, FF, Moving the horizontal position

Format

ASCII	ESC	\	n _L	n _H
Hex	1B	5C	n _L	n _H
Decimal	27	92	n _L	n _H

Parameter range

$$0 \leq n_H \leq 127$$

$$0 \leq n_L \leq 255$$

Function

Moves the horizontal print position left or right from the current position, as specified by the following formula:

$$(\text{horizontal position}) = ((n_H \times 256) + n_L) \times (\text{defined unit}) + (\text{current position})$$

For positive (right) movement:

$$n_H = \text{INT} \left(\frac{((\text{horizontal position}) - (\text{current position})) \times \frac{1}{(\text{defined unit})}}{256} \right)$$

$$n_L = \text{MOD} \left(\frac{((\text{horizontal position}) - (\text{current position})) \times \frac{1}{(\text{defined unit})}}{256} \right)$$

For negative (left) movement:

$$n_H = 32768 - \text{INT} \left(\frac{((\text{current position}) - (\text{horizontal position})) \times \frac{1}{(\text{defined unit})}}{256} \right)$$

$$n_L = 32768 - \text{MOD} \left(\frac{((\text{current position}) - (\text{horizontal position})) \times \frac{1}{(\text{defined unit})}}{256} \right)$$

Notes

- Set the defined unit with the ESC (U command.
- The default defined unit for this command is 1/120 inch in draft mode, and 1/180 inch in LQ mode.
- The printer ignores this command if it would move the print position outside the printing area.

Printers not featuring this command

None

Model-dependent variations

On non-ESC/P 2 printers, the unit of movement is fixed at 1/120 inch in draft mode and 1/180 inch in LQ mode.

Related topics

ESC \$, ESC I, ESC Q, ESC (U, HT, CR, LF, FF, Moving the horizontal position

Format

ASCII	ESC	\	n _L	n _H
Hex	1B	5C	n _L	n _H
Decimal	27	92	n _L	n _H

Parameter range

$$0 \leq n_H \leq 127$$

$$0 \leq n_L \leq 255$$

Function

Moves the horizontal print position left or right from the current position, as specified by the following formula:

$$(\text{horizontal position}) = ((n_H \times 256) + n_L) \times (1/120 \text{ inch}) + (\text{current margin})$$

For positive (right) movement:

$$n_H = \text{INT} \left(\frac{((\text{horizontal position}) - (\text{current position})) \times \frac{1}{(1/120 \text{ inch})}}{256} \right)$$

$$n_L = \text{MOD} \left(\frac{((\text{horizontal position}) - (\text{current position})) \times \frac{1}{(1/120 \text{ inch})}}{256} \right)$$

For negative (left) movement:

$$n_H = 32768 - \text{INT} \left(\frac{((\text{current position}) - (\text{horizontal position})) \times \frac{1}{(1/120 \text{ inch})}}{256} \right)$$

$$n_L = 32768 - \text{MOD} \left(\frac{((\text{current position}) - (\text{horizontal position})) \times \frac{1}{(1/120 \text{ inch})}}{256} \right)$$

Notes

The printer ignores this command if it would move the print position outside the printable area.

Printers not featuring this command

ActionPrinter Apex 80, ActionPrinter T-1000, ActionPrinter 2000, ActionPrinter 2250,
ActionPrinter 2500, LX-100, LX-300, LX-400, LX-800, LX-810, LX-850, LX-1050

Model-dependent variations

DFX-5000, DFX-8000: This command can be used only in LQ mode.

Related topics

ESC \, ESC I, ESC Q, HT, CR, LF, FF, Moving the horizontal position

Format

ASCII	ESC	(V	n _L	n _H	m _L	m _H
Hex	1B	28	56	n _L	n _H	m _L	m _H
Decimal	27	40	86	n _L	n _H	m _L	m _H

Parameter range

n_L = 2, n_H = 0

0 ≤ m_L ≤ 255, 0 ≤ m_H ≤ 127

Function

Moves the vertical print position to the position specified by the following formula:

(vertical position) = ((m_H × 256) + m_L) × (defined unit) + (top-margin position)

$$m_H = \text{INT} \left(\frac{((\text{vertical position}) - (\text{top-margin position})) \times \frac{1}{(\text{defined unit})}}{256} \right)$$

$$m_L = \text{MOD} \left(\frac{((\text{vertical position}) - (\text{top-margin position})) \times \frac{1}{(\text{defined unit})}}{256} \right)$$

Notes

- This command is available only on printers featuring ESC/P 2.
- Set the defined unit using the ESC (U command.
- The default defined unit for this command is 1/360 inch.
- The new position is measured in defined units from the current top-margin position.
- Moving the print position below the bottom-margin position produces the following results:

Continuous paper	Moves the vertical print position to the top-margin position on the next page
Single-sheet paper	Ejects the paper
- The printer ignores this command under the following conditions:
 - The command would move the print position more than 179/360 inch in the negative direction
 - The command would move the print position in the negative direction after a graphics command is sent on the current line, or above the point where graphics have previously been printed

Printers not featuring this command

All non-ESC/P 2 printers

Model-dependent variations

None

Related topics

CR, LF, FF, VT, ESC B, ESC (U, Moving the vertical position

Format

ASCII	ESC	(v	n _L	n _H	m _L	m _H
Hex	1B	28	76	n _L	n _H	m _L	m _H
Decimal	27	40	118	n _L	n _H	m _L	m _H

Parameter range

$$n_L = 2, n_H = 0$$

$$0 \leq m_L \leq 255, 0 \leq m_H \leq 127$$

Function

Moves the vertical print position up or down from the current position, as specified by the following formula:

$$(\text{horizontal position}) = ((m_H \times 256) + m_L) \times (\text{defined unit}) + (\text{current position})$$

For positive (down) movement:

$$m_H = \text{INT} \left(\frac{((\text{vertical position}) - (\text{current position})) \times \frac{1}{(\text{defined unit})}}{256} \right)$$

$$m_L = \text{MOD} \left(\frac{((\text{vertical position}) - (\text{current position})) \times \frac{1}{(\text{defined unit})}}{256} \right)$$

For negative (up) movement:

$$m_H = 32768 - \text{INT} \left(\frac{((\text{current position}) - (\text{vertical position})) \times \frac{1}{(\text{defined unit})}}{256} \right)$$

$$m_L = 32768 - \text{MOD} \left(\frac{((\text{current position}) - (\text{vertical position})) \times \frac{1}{(\text{defined unit})}}{256} \right)$$

Notes

- This command is available only on printers featuring ESC/P 2.
- Set the defined unit using the ESC (U command.
- The default defined unit for this command is 1/360 inch.
- The new position is measured in defined units from the current position.

- Moving the print position below the bottom-margin position produces the following results:
 - Continuous paper Moves the vertical print position to the top-margin position on the next page
 - Single-sheet paper Ejects the paper
- The printer ignores this command under the following conditions:
 - The command would move the print position more than 179/360 inch in the negative direction.
 - The command would move the print position in the negative direction after a graphics command is sent on the current line, or above the point where graphics have previously been printed.
 - The command would move the print position above the top-margin position.

Printers not featuring this command

All non-ESC/P 2 printers

Model-dependent variations

None

Related topics

CR, LF, FF, VT, ESC (U, ESC B, Moving the vertical position

Format

ASCII	ESC	J	n
Hex	1B	4A	n
Decimal	27	74	n

Parameter range $0 \leq n \leq 255$ **Function**

Advances the vertical print position $n/180$ inch

Notes

- ESC J does not affect the horizontal print position.
- Moving the print position below the bottom-margin position produces the following results:

Continuous paper	Moves the vertical print position to the top-margin position on the next page
Single-sheet paper	Ejects the paper

Printers not featuring this command

None

Model-dependent variations

On non-ESC/P 2 printers:

- Prints all data in the line buffer
- Advances paper to the top-of-form position on the next page if the ESC J command moves the print position below the bottom-margin position set with the ESC N command
- Ejects single-sheet paper if the ESC J command moves the print position beyond the end of the printable area (and paper was loaded by cut-sheet feeder)
- Ejects single-sheet paper and advances the next single sheet the remaining distance if the ESC J command moves the print position beyond the end of the printable area (and paper was loaded manually)

Related topics

CR, LF, FF, VT, ESC (U, ESC B, ESC (V, ESC (v, Moving the vertical position

Format

ASCII	ESC	J	n
Hex	1B	4A	n
Decimal	27	74	n

Parameter range

$0 \leq n \leq 255$

Function

- Prints data in buffer
- Advances the vertical print position $n/216$ inch

Notes

- ESC J does not affect the horizontal print position.
- If the ESC J command moves the print position on continuous paper below the bottom-margin position set with the ESC N command, the printer advances to the top-of-form position on the next page.
- If ESC J moves the print position on single-sheet paper below the end of the printable area, the printer ejects the paper (if loaded by cut-sheet feeder) or ejects paper and then feeds next sheet remaining distance (if loaded manually).

Printers not featuring this command

None

Model-dependent variations

None

Related topics

CR, LF, FF, VT, ESC B, Moving the vertical position

Format

ASCII	HT
Hex	09
Decimal	9

Function

Moves the horizontal print position to the next tab to the right of the current print position

Notes

- The printer ignores this command if no tab is set to the right of the current position or if the next tab is to the right of the right margin.
- Character scoring (underline, overscore, and strikethrough) is not printed between the current print position and the next tab when this command is sent.

Printers not featuring this command

None

Model-dependent variations

None

Related topics

ESC D, ESC \$, ESC \, ESC I, ESC Q, CR, Moving the horizontal position

Format

ASCII	HT
Hex	09
Decimal	9

Function

Moves the horizontal print position to the next tab to the right of the current print position

Notes

- The printer ignores this command if no tab is set to the right of the current position or if the next tab is to the right of the right margin.
- Underlines are not printed between the current print position and the next tab when this command is sent.

Printers not featuring this command

None

Model-dependent variations

None

Related topics

ESC D, ESC \$, ESC \, CR, ESC I, ESC Q, Moving the horizontal position

Format

ASCII	VT
Hex	0B
Decimal	11

Function

- Moves the vertical print position to the next vertical tab below the current print position
- Moves the horizontal print position to the left-margin position

Notes

- The printer advances to the top-margin position of the following page if the next tab is below the bottom-margin position or if no tab is set below the current position.
- The VT command functions the same as a CR command (moves the horizontal print position to the left-margin position) if all tabs have been canceled with the ESC B NUL command.
- The VT command functions the same as an LF command (advances one line in the current line spacing and moves the horizontal print position to the left-margin position) if no tabs have been set since the printer was turned on or was reset with the ESC @ command.
- The VT command functions the same as an FF command (advances to the top-margin position on the next page) if some tabs have been set, but no tab is set between the current print position and the bottom-margin position.
- This command cancels double-width printing set with the SO or ESC SO command.

Printers not featuring this command

None

Model-dependent variations

On non-ESC/P 2 printers:

- The printer advances to the top-of-form position on the next page if the next tab is beyond the currently set page length.
- The printer ignores a VT command that would move the print position inside the bottom margin.

Related topics

ESC (V, ESC (v, ESC B, CR, LF, FF, Moving the vertical position

Format

ASCII	VT
Hex	0B
Decimal	11

Function

- Moves the vertical print position to the next vertical tab below the current print position
- Moves the horizontal print position to the left-margin position

Notes

- The printer advances to the top-of-form position on the following page if the next tab is beyond the currently set page length, or beyond the bottom-margin position.
- The VT command functions the same as a CR command (moves the horizontal print position to the left-margin position) if all tabs have been canceled with the ESC B NUL command.
- The VT command functions the same as an LF command (advances one line in the current line spacing and moves the horizontal print position to the left-margin position) if no tabs have been set since the printer was turned on or was reset with the ESC @ command.
- This command cancels double-width printing set with the SO or ESC SO command.

Printers not featuring this command

None

Model-dependent variations

None

Related topics

ESC B, CR, LF, FF, Moving the vertical print position

Format

ASCII	ESC	f	m	n
Hex	1B	66	m	n
Decimal	27	102	m	n

Parameter range $0 \leq n \leq 127$ $m = 0, 1$ **Function**

Moves the print position depending on the value of m, as follows:

- m = 0 Prints n spaces in the current pitch.
- 1 Performs n line feeds, in the current line spacing
 Moves the horizontal print position to the left-margin position.

Notes

- This is a nonrecommended command.
- Underline is performed between the current and final print positions when this command is used to move the print position horizontally (m = 0).
- Using this command to move the print position vertically (m = 1) cancels double-width printing selected with the SO or ESC SO command.

Printers not featuring this command

ActionPrinter T-750, ActionPrinter 2500, DFX-5000+, DFX-5000, DFX-8000, FX-850, FX-1050

Model-dependent variations

None

Related topics

HT, VT, LF, ESC \$, ESC \, Moving the vertical position

Format

ASCII	BS
Hex	08
Decimal	8

Function

Moves the print position to the left a distance equal to one character in the current character pitch plus any additional intercharacter space.

Notes

- This is a nonrecommended command.
- The printer ignores this command if it would move the print position to the left of the left margin.

Printers not featuring this command

None

Model-dependent variations

None

Related topics

ESC \$, ESC \, HT, DEL, Moving the horizontal position

Format

ASCII	BS
Hex	08
Decimal	8

Function

Moves the print position to the left a distance equal to one character in the current pitch plus any additional intercharacter space

Notes

- This is a nonrecommended command.
- The printer ignores this command if it would move the print position to the left of the left margin.

Printers not featuring this command

None

Model-dependent variations

None

Related topics

ESC \$, ESC \, HT, CR, Moving the horizontal position

Format

ASCII	ESC	(U	n _L	n _H	m
Hex	1B	28	55	n _L	n _H	m
Decimal	27	40	85	n _L	n _H	m

Parameter range

n_L = 1, n_H = 0

m = 5, 10, 20, 30, 40, 50, 60

Function

Sets the unit to m/3600 inch. The printer uses this unit when moving the print position, setting the page length, and setting the top and bottom margins with the following commands: ESC (V, ESC (v, ESC \, ESC \$, ESC (C, ESC (c, <MOVX>, and <MOVY>.

Default

The default unit varies depending on the command and print quality, as follows:

ESC (V	1/360 inch
ESC (v	1/360 inch
ESC (C	1/360 inch
ESC (c	1/360 inch
ESC \ (LQ mode)	1/180 inch
ESC \ (draft mode)	1/120 inch
ESC \$	1/60 inch
<MOVX> (dot)	1/360 inch
<MOVY>	1/360 inch

Notes

- This command is available only on printers featuring ESC/P 2.
- The parameter and related commands highlighted in bold are new to this command and only apply to the Stylus COLOR and later inkjet printer models.

Printers not featuring this command

All non-ESC/P 2 printers

Model-dependent variations

None

Related topics

HT, VT, CR, LF, FF, Set the Printing Area, Select the print position, Graphics mode

Format

ASCII	ESC	0
Hex	1B	30
Decimal	27	48

Function

Sets the line spacing to 1/8 inch

Default

1/6-inch line spacing

Notes

- Changing the line spacing does not affect previous settings for vertical tabs or page length.
- This command uses the ASCII code for the character 0 (zero), not a capital O or the number 0.

Printers not featuring this command

None

Model-dependent variations

None

Related topics

ESC 2, ESC 3, ESC +, ESC C, ESC N, ESC B, LF, Setting page length, Moving the vertical position

Format

ASCII	ESC	0
Hex	1B	30
Decimal	27	48

Function

Sets the line spacing to 1/8 inch

Default

1/6-inch line spacing

Notes

- Changing the line spacing does not affect previous settings for vertical tabs or page length.
- This command uses the ASCII code for the character 0 (zero), not the number 0.

Printers not featuring this command

None

Model-dependent variations

None

Related topics

ESC 2, ESC 3, ESC N, ESC C, ESC B, LF, Setting page length, Moving the vertical position

Format

ASCII	ESC	2
Hex	1B	32
Decimal	27	50

Function

Sets the line spacing to 1/6 inch

Default

1/6-inch line spacing

Notes

- This command uses the ASCII code for the character 2, not the number 2.
- Changing the line spacing does not affect previous settings for vertical tabs or page length.

Printers not featuring this command

None

Model-dependent variations

None

Related topics

ESC 0, ESC 3, ESC +, ESC C, ESC N, ESC B, LF, Setting page length, Moving the vertical position

Format

ASCII	ESC	2
Hex	1B	32
Decimal	27	50

Function

Sets the line spacing to 1/6 inch

Default

1/6-inch line spacing

Notes

- This command uses the ASCII code for the character 2, not the number 2.
- Changing the line spacing does not affect previous settings for vertical tabs or page length.

Printers not featuring this command

None

Model-dependent variations

None

Related topics

ESC 0, ESC 3, ESC N, ESC C, ESC B, LF, Setting page length, Moving the vertical position

Format

ASCII	ESC	3	n
Hex	1B	33	n
Decimal	27	51	n

Parameter range

$0 \leq n \leq 255$

Function

Sets the line spacing to n/180 inch

Default

1/6-inch line spacing

Notes

- This command uses the ASCII code for the character 3, not the number 3.
- Changing the line spacing does not affect previous settings for vertical tabs or page length.

Printers not featuring this command

None

Model-dependent variations

None

Related topics

ESC 0, ESC 2, ESC +, ESC N, ESC C, ESC B, LF, Setting page length, Moving the vertical position

Format

ASCII	ESC	3	n
Hex	1B	33	n
Decimal	27	51	n

Parameter range

$0 \leq n \leq 255$

Function

Sets the line spacing to n/216 inch

Default

1/6-inch line spacing

Notes

- This command uses the ASCII code for the character 3, not the number 3.
- Changing the line spacing does not affect previous settings for vertical tabs or page length.

Printers not featuring this command

None

Model-dependent variations

None

Related topics

ESC 0, ESC 2, ESC N, ESC C, ESC B, LF, Setting page length, Moving the vertical position

Format

ASCII	ESC	+	n
Hex	1B	2B	n
Decimal	27	43	n

Parameter range

0 ≤ n ≤ 255

Function

Sets the line spacing to n/360 inch

Default

1/6-inch line spacing

Notes

- Changing the line spacing does not affect previous settings for vertical tabs or page length.
- This command is available only on 24/48-pin printers.
- This is the recommended command for setting line spacing.

Printers not featuring this command

ActionPrinter L-1000, ActionPrinter 3000, LQ-200, LQ-400, LQ-500

Model-dependent variations

None

Related topics

ESC 0, ESC 2, ESC 3, ESC N, ESC C, ESC B, LF, Setting page length, Moving the vertical position

Format

ASCII	ESC	A	n
Hex	1B	41	n
Decimal	27	65	n

Parameter range $0 \leq n \leq 85$ **Function**

Sets the line spacing to n/60 inch

Default

1/6-inch line spacing

Notes

- This is a nonrecommended command; use the ESC + or ESC 3 command instead.
- Changing the line spacing does not affect previous settings for vertical tabs or page length.

Printers not featuring this command

None

Model-dependent variations

None

Related topics

ESC +, ESC 0, ESC 2, ESC 3, ESC N, ESC C, ESC B, LF, Setting page length, Moving the vertical position

Format

ASCII	ESC	A	n
Hex	1B	41	n
Decimal	27	65	n

Parameter range

$0 \leq n \leq 85$

Function

Sets the line spacing to n/72 inch

Default

1/6-inch line spacing

Notes

- This is a nonrecommended command; use the ESC 3 command instead.
- Changing the line spacing does not affect previous settings for vertical tabs or page length.

Printers not featuring this command

None

Model-dependent variations

None

Related topics

ESC 0, ESC 2, ESC 3, ESC N, ESC C, ESC B, LF, Setting page length, Moving the vertical position

Format

ASCII	ESC	1
Hex	1B	31
Decimal	27	49

Function

Sets the line spacing to 7/72 inch

Default

1/6-inch line spacing

Notes

- This is a nonrecommended command; use the ESC 3 command instead.
- This command is available only on 9-pin printers.
- This command uses the ASCII code for the character 1, not the number 1.
- Changing the line spacing does not affect previous settings for vertical tabs or page length.

Printers not featuring this command

None

Model-dependent variations

None

Related topics

ESC 0, ESC 2, ESC 3, ESC N, ESC C, ESC B, LF, Setting page length, Moving the vertical position

Format

ASCII	ESC	D	n ₁	n ₂	...	n _k	NUL
Hex	1B	44	n ₁	n ₂	...	n _k	00
Decimal	27	68	n ₁	n ₂	...	n _k	0

Parameter range

$$0 \leq k \leq 32$$

$$1 \leq n \leq 255$$

$$n_k > n_{(k-1)}$$

Function

Sets horizontal tab positions (in the current character pitch) at the columns specified by n₁ to n_k, as measured from the left-margin position

Default

Every eight characters

Notes

- The values for n must be in ascending order; a value of n less than the previous n ends tab setting (like the NUL code).
- Changing the character pitch does not affect current tab settings.
- Send an ESC D NUL command to cancel all tab settings.
- The tab settings move to match any movement in the left margin.
- A maximum of 32 horizontal tabs can be set.
- The printer does not move the print position to any tabs beyond the right-margin position. However, all tab settings are stored in the printer's memory; if you move the right margin, you can access previously ignored tabs.
- The printer calculates tab positions based on 10 cpi if proportional spacing is selected with the ESC p command.
- Sending the ESC D command clears any previous tab settings.

Printers not featuring this command

None

Model-dependent variations

None

Related topics

ESC \$, ESC \, ESC P, ESC M, ESC p, ESC l, ESC Q, Setting the left and right margins, Moving the horizontal position

Format

ASCII	ESC	D	n ₁	n ₂	...	n _k	NUL
Hex	1B	44	n ₁	n ₂	...	n _k	00
Decimal	27	68	n ₁	n ₂	...	n _k	0

Parameter range

$$0 \leq k \leq 32$$

$$1 \leq n \leq 255$$

$$n_k > n_{(k-1)}$$

Function

Sets horizontal tab positions (in the current character pitch) at the columns specified by n₁ to n_k, as measured from the left-margin position

Default

Every eight characters

Notes

- The values for n must be in ascending order; a value of n less than the previous n ends tab setting (like the NUL code).
- Changing the character pitch does not affect current tab settings.
- Send an ESC D NUL command to cancel all tab settings.
- The tab settings move to match any movement in the left margin.
- A maximum of 32 horizontal tabs can be set.
- The printer does not move the print position to any tabs beyond the right-margin position. However, all tab settings are stored in the printer's memory; if you move the right margin, you can access previously ignored tabs.
- The printer calculates tab positions based on 10 cpi if proportional spacing is selected with the ESC p command.
- Sending the ESC D command clears any previous tab settings.

Printers not featuring this command

None

Model-dependent variations

None

Related topics

ESC \$, ESC \, ESC P, ESC M, ESC p, ESC l, ESC Q, Setting the left and right margins, Moving the horizontal position

Format

ASCII	ESC	B	n ₁	n ₂	...	n _k	NUL
Hex	1B	42	n ₁	n ₂	...	n _k	00
Decimal	27	66	n ₁	n ₂	...	n _k	0

Parameter range

$$0 \leq k \leq 16$$

$$1 \leq n \leq 255$$

$$n_k > n_{(k-1)}$$

Function

Sets vertical tab positions (in the current line spacing) at the lines specified by n₁ to n_k, as measured from the top-margin position

Notes

- The values for n must be in ascending order; a value of n less than the previous n ends tab setting (just like the NUL code).
- Changing the line spacing does not affect previous tab settings.
- The tab settings move to match any subsequent movement in the top-margin position.
- Send an ESC B NUL command to cancel all tab settings.
- A maximum of 16 vertical tabs can be set.
- The printer stores all tab settings, even if outside the printing area; if you increase the page length to include previously set tabs, you can move to those positions with the VT (tab vertically) command.
- Sending the ESC B command clears any previous tab settings.

Printers not featuring this command

None

Model-dependent variations

On non-ESC/P 2 printers:

- Vertical tabs are measured from the top-of-form position.
- Setting vertical tabs with ESC B is the same as setting the vertical tabs in VFU channel 0.

Related topics

ESC (V, ESC (v, ESC J, ESC (C, ESC (C, ESC (c, ESC C, ESC N, ESC 0, ESC 2, ESC 3, ESC +, Setting page length, Setting top and bottom margins, Moving the vertical position

Format

ASCII	ESC	B	n ₁	n ₂	...	n _k	NUL
Hex	1B	42	n ₁	n ₂	...	n _k	00
Decimal	27	66	n ₁	n ₂	...	n _k	0

Parameter range

$$0 \leq k \leq 16$$

$$1 \leq n \leq 255$$

$$n_k > n_{(k-1)}$$

Function

Sets vertical tab positions (in the current line spacing) at the lines specified by n₁ to n_k, as measured from the top-of-form position

Notes

- The values for n must be in ascending order; a value of n less than the previous n ends tab setting (like the NUL code).
- Changing the line spacing does not affect previous tab settings.
- Send an ESC B NUL command to cancel all tab settings.
- A maximum of 16 vertical tabs can be set.
- The printer stores all tab settings, even if outside the printing area; if you increase the page length to include previously set tabs, you can move to those positions with the VT (tab vertically) command.
- Sending the ESC B command clears any previous tab settings.
- Setting vertical tabs with ESC B is the same as setting the vertical tabs in VFU channel 0.

Printers not featuring this command

None

Model-dependent variations

None

Related topics

ESC J, ESC C, ESC N, ESC 0, ESC 2, ESC 3, Setting page length, Setting bottom margin, Moving the vertical position

Format

ASCII	ESC	b	m	n ₁	...	n _k	NUL
Hex	1B	62	m	n ₁	...	n _k	00
Decimal	27	98	m	n ₁	...	n _k	0

Parameter range

$$0 \leq m \leq 7$$

$$1 \leq n \leq 255$$

$$n_k > n_{(k-1)}$$

$$1 \leq k \leq 16$$

Function

Sets vertical tab positions at the lines specified by n₁ to n_k (in the current line spacing) in tab set m, as measured from the top-of-form position

Notes

- This is a nonrecommended command.
- This command is deleted in ESC/P 2.
- Up to eight sets of tabs can be set.
- The value for m specifies the number of the tab set being changed; these sets of tabs are called vertical formatting unit (VFU) channels.
- The values for n must be in ascending order; a value of n less than the previous n ends tab setting (just like the NUL code).
- Send the ESC / command to select a VFU channel other than channel 0; the VT (tab vertically) command then uses the settings for the selected channel.
- Changing the line spacing does not affect previous tab settings.
- Sending the ESC b command clears any previous tab settings in that tab set.
- Send an ESC b m NUL command to cancel all tab settings in tab set m.
- A maximum of 16 vertical tabs can be set in each VFU channel.
- The printer stores all tab settings, even if outside the printing area; if you increase the page length to include previously set tabs, you can move to those positions with the VT (tab vertically) command.

Printers not featuring this command

All ESC/P 2 printers, ActionPrinter 3000, LQ-200

Model-dependent variations

None

Related topics

ESC \, VT, ESC 0, ESC 2, ESC 3, ESC +, Setting page length, Setting bottom margin, Moving the vertical position

Format

ASCII	ESC	b	m	n ₁	...	n _k	NUL
Hex	1B	62	m	n ₁	...	n _k	00
Decimal	27	98	m	n ₁	...	n _k	0

Parameter range

$$0 \leq m \leq 7$$

$$1 \leq n \leq 255$$

$$n_k > n_{(k-1)}$$

$$1 \leq k \leq 16$$

Function

Sets vertical tab positions at the lines specified by n₁ to n_k (in the current line spacing) in tab set m, as measured from the top-of-form position

Notes

- This is a nonrecommended command.
- Up to eight sets of tabs can be set.
- The value for m specifies the number of the tab set being changed; these sets of tabs are called vertical formatting unit (VFU) channels.
- The values for n must be in ascending order; a value of n less than the previous n ends tab setting (like the NUL code).
- Send the ESC / command to select a VFU channel other than channel 0; the VT (tab vertically) command then uses the settings for the selected channel.
- Changing the line spacing does not affect previous tab settings.
- Sending the ESC b command clears any previous tab settings in that tab set.
- Send an ESC b m NUL command to cancel all tab settings in tab set m.
- A maximum of 16 vertical tabs can be set in each VFU channel.
- The printer stores all tab settings, even if outside the printing area; if you increase the page length to include previously set tabs, you can move to those positions with the VT (tab vertically) command.

Printers not featuring this command

None

Model-dependent variations

None

Related topics

ESC /, VT, ESC 0, ESC 2, ESC 3, Setting page length, Setting bottom margin, Moving the vertical position

Format

ASCII	ESC	/	m
Hex	1B	2F	m
Decimal	27	47	m

Parameter range

$$0 \leq m \leq 7$$

Function

Selects vertical tab set m

Default

Tab channel 0

Notes

- This is a nonrecommended command.
- This command is deleted in ESC/P 2.
- The value for m specifies the number of the tab set being changed; these sets of tabs are called vertical formatting unit (VFU) channels.
- You must use this command to select a tab set (VFU channel) other than set 0; the VT (tab vertically) command then uses the settings for the selected channel.
- You can select from eight sets of tabs (VFU channels).

Printers not featuring this command

All ESC/P 2 printers, ActionPrinter 3000, LQ-200

Model-dependent variations

None

Related topics

ESC b, ESC B, VT, Moving the vertical position

Format

ASCII	ESC	/	m
Hex	1B	2F	m
Decimal	27	47	m

Parameter range

$$0 \leq m \leq 7$$

Function

Selects vertical tab set m

Default

Tab channel 0

Notes

- This is a nonrecommended command.
- The value for m specifies the number of the tab set being changed; these sets of tabs are called vertical formatting unit (VFU) channels.
- You must use this command to select a tab set (VFU channel) other than set 0; the VT (tab vertically) command then uses the settings for the selected channel.
- You can select from eight sets of tabs (VFU channels).

Printers not featuring this command

None

Model-dependent variations

None

Related topics

ESC b, ESC B, VT, Moving the vertical position

Format

ASCII	ESC	e	m	n
Hex	1B	65	m	n
Decimal	27	101	m	n

Parameter range

m = 0, 1

horizontal tabs (m=0)

0 ≤ n ≤ 21 10 cpi

0 ≤ n ≤ 25 12 cpi

0 ≤ n ≤ 36 Condensed printing

vertical tabs (m=1)

0 ≤ n ≤ 127

(line spacing) × n < (page length)

Function

Sets fixed tabs, as follows:

- | | |
|-------|---|
| m = 0 | Sets vertical tabs every n lines in the current line spacing, as measured from the top-of-form position |
| 1 | Sets horizontal tabs every n characters in the current character pitch |

Default

Horizontal tabs: Every eight characters

Vertical tabs: None

Notes

- This is a nonrecommended command.
- Use the VT command to move to the next vertical tab or the HT command to move to the next horizontal tab.
- The ESC e command clears previously set tabs.
- The printer ignores this command if the value for n would make the vertical tab increment longer than the current page length, or if n is greater than the maximum for the current character pitch.

Printers not featuring this command

DFX-5000+, DFX-5000, DFX-8000, FX-850, FX-1050

Model-dependent variations

None

Related topics

VT, HT, ESC B, ESC D, ESC P, ESC M, SO, ESC 0, ESC 2, ESC 3, Moving the horizontal position, Moving the vertical position

Format

ASCII	ESC	a	n
Hex	1B	61	n
Decimal	27	97	n

Parameter range

$$0 \leq n \leq 3$$

Function

Selects from four types of justification, as follows:

n = 0 or 48	Flush left
1 or 49	Centered
2 or 50	Flush right
3 or 51	Full justification (flush right and left)

Default

Flush left

Notes

- This is a nonrecommended command.
- This command has been deleted in ESC/P 2 printers.
- Always set justification at the beginning of a line.
- The printer performs full justification only if the width of the current line is greater than 75% of the printing area width. If the line width is less than 75%, the printer left-justifies text.
- You should not use commands that adjust the horizontal print position during full justification. These commands are: DEL, HT, BS, ESC f 0, ESC \$, and ESC \.
- Justification is based on the font selected when the justification command is sent. Changing the font after setting justification can cause unpredictable results.

Printers not featuring this command

All ESC/P 2 printers, ActionPrinter 3000, LQ-200

Model-dependent variations

None

Related topics

ESC P, ESC M, ESC g, SO, ESC SP, ESC \$, ESC \, Moving the horizontal position, Selecting the pitch

Format

ASCII	ESC	a	n
Hex	1B	61	n
Decimal	27	97	n

Parameter range $0 \leq n \leq 3, 48 \leq n \leq 51$ **Function**

Selects from four types of justification, as follows:

n = 0 or 48	Flush left
1 or 49	Centered
2 or 50	Flush right
3 or 51	Full justification (flush right and left)

Default

Flush left

Notes

- This is a nonrecommended command.
- Always set justification at the beginning of a line.
- The printer performs full justification only if the width of the current line is greater than 75% of the printing area width. If the line width is less than 75%, the printer left-justifies text.
- You should not use commands that adjust the horizontal print position during full justification. These commands are: DEL, HT, BS, ESC f 0, ESC \$, and ESC \.
- Justification is based on the font selected when the justification command is sent. Changing the font after setting justification can cause unpredictable results.

Printers not featuring this command

None

Model-dependent variations

ActionPrinter Apex 80, ActionPrinter T-1000, ActionPrinter 2250, LX-100, LX-300, LX-800, LX-810. Justification is available only in LQ mode.

Related topics

ESC P, ESC M, SO, ESC SP, ESC \$, ESC \, Moving the horizontal position, Selecting the pitch

Format

ASCII	ESC	(t	n _L	n _H	d ₁	d ₂	d ₃
Hex	1B	28	74	n _L	n _H	d ₁	d ₂	d ₃
Decimal	27	40	116	n _L	n _H	d ₁	d ₂	d ₃

Parameter range

$n_L = 3, n_H = 0$

$0 \leq d_1 \leq 3, 48 \leq d_1 \leq 51$

$0 \leq d_2 \leq 255$

$0 \leq d_3 \leq 255$

Function

Assigns the d₂ registered character table to the d₁ character table according to the following values (the d₁ character table is one of the four tables selectable with the ESC t command):

d ₂	d ₃	Table name
0	0	Italic
1	0	PC437 (US)
1	16	PC437 Greek
2	0	PC932 (Japanese)
3	0	PC850 (Multilingual)
4	0	PC851 (Greek)
5	0	PC853 (Turkish)
6	0	PC855 (Cyrillic)
7	0	PC860 (Portugal)
8	0	PC863 (Canada-French)
9	0	PC865 (Norway)
10	0	PC852 (East Europe)
11	0	PC857 (Turkish)
12	0	PC862 (Hebrew)
13	0	PC864 (Arabic)
13	32	PC AR864
14	0	PC866 (Russian)
14	16	(Bulgarian ASCII****)
14	32	PC866 LAT. (Latvian)
15	0	PC869 (Greek)
16	0	USSR GOST (Russian)
17	0	ECMA-94-1
18	0	KU42 (K.U. Thai)
19	0	TIS11 (TS 988 Thai)
20	0	TIS18 (GENERAL Thai)
21	0	TIS17 (SIC STD. Thai)
22	0	TIS13 (IBM STD. Thai)
23	0	TIS16 (SIC OLD Thai)
24	0	PC861 (Iceland)
25	0	BRASCII

d ₂	d ₃	Table name
26	0	Abicomp
27	0	MAZOWIA (Poland)
28	0	Code MJK (CSFR)
29	7	ISO8859-7 (Latin/Greek)
29	16	ISO8859-1 (Latin 1)
30	0	TSM/WIN (Thai system manager)
31	0	ISO Latin 1T (Turkish)
32	0	Bulgaria
33	0	Hebrew 7
34	0	Hebrew 8
35	0	Roman 8
36	0	PC774 (Lithuania)
37	0	Estonia (Estonia)
38	0	ISCII
39	0	PC-ISCII
40	0	PC APTEC
41	0	PC708
42	0	PC720
112	0	OCR-B
127	1	ISO Latin 1
127	2	ISO 8859-2 (ISO Latin 2)
127	7	ISO Latin 7 (Greek)

Printers not featuring this command

All non-ESC/P 2 printers

Model-dependent variations

Not all models feature all character tables. See the Command Table section for the character tables available on each printer model.

Related topics

ESC t, Assign character tables, Selecting the character table

Format

ASCII	ESC	(t	n _L	n _H	d ₁	d ₂	d ₃
Hex	1B	28	74	n _L	n _H	d ₁	d ₂	d ₃
Decimal	27	40	116	n _L	n _H	d ₁	d ₂	d ₃

Parameter range

- n_L = 3, n_H = 0
- 0 ≤ d₁ ≤ 1, 48 ≤ d₁ ≤ 49
- 0 ≤ d₂ ≤ 255
- 0 ≤ d₃ ≤ 255

Function

Assigns the d₂ registered character table to the d₁ character table according to the following values (the d₁ character table is one of the four tables selectable with the ESC t command):

d ₂	d ₃	Table name
0	0	Italic
1	0	PC437 (US)
1	16	PC437 Greek
2	0	PC932 (Japanese)
3	0	PC850 (Multilingual)
4	0	PC851 (Greek)
5	0	PC853 (Turkish)
6	0	PC855 (Cyrillic)
7	0	PC860 (Portugal)
8	0	PC863 (Canada-French)
9	0	PC865 (Norway)
10	0	PC852 (East Europe)
11	0	PC857 (Turkish)
12	0	PC862 (Hebrew)
13	0	PC864 (Arabic)
13	32	PC AR864
14	0	PC866 (Russian)
14	16	(Bulgarian ASCII****)
14	32	PC866 LAT. (Latvian)
15	0	PC869 (Greek)
16	0	USSR GOST (Russian)
17	0	ECMA-94-1
18	0	KU42 (K.U. Thai)
19	0	TIS11 (TS 988 Thai)
20	0	TIS18 (GENERAL Thai)
21	0	TIS17 (SIC STD. Thai)
22	0	TIS13 (IBM STD. Thai)
23	0	TIS16 (SIC OLD Thai)
24	0	PC861 (Iceland)
25	0	BRASCII

d ₂	d ₃	Table name
26	0	Abicomp
27	0	MAZOWIA (Poland)
28	0	Code MJK (CSFR)
29	7	ISO8859-7 (Latin/Greek)
29	16	ISO8859-1 (Latin 1)
30	0	TSM/WIN (Thai system manager)
31	0	ISO Latin 1T (Turkish)
32	0	Bulgaria
33	0	Hebrew 7
34	0	Hebrew 8
35	0	Roman 8
36	0	PC774 (Lithuania)
37	0	Estonia (Estonia)
38	0	ISCII
39	0	PC-ISCII
40	0	PC APTEC
41	0	PC708
42	0	PC720
112	0	OCR-B
127	1	ISO Latin 1
127	2	ISO 8859-2 (ISO Latin 2)
127	7	ISO Latin 7 (Greek)

Printers not featuring this command

ActionPrinter T-750, ActionPrinter T-1000, ActionPrinter Apex80, ActionPrinter 2000, ActionPrinter 2500, DFX-5000, DFX-8000, FX-850, FX-1050, LX-400, LX-800, LX-810, LX-850, LX-1050

Model-dependent variations

Not all models feature all character tables. See the Command Table section for the character tables available on each printer model.

Related topics

ESC t, Assign character tables, Selecting the character table

Format

ASCII	ESC	t	n
Hex	1B	74	n
Decimal	27	116	n

Parameter range

$0 \leq n \leq 3, 48 \leq n \leq 51$

Function

Selects the character table to be used for printing from among the four character tables described below:

n = 0 or 48	Character table 0
1 or 49	Character table 1
2 or 50	Character table 2
3 or 51	Character table 3

Default

table 0	Italic
table 1	PC437
table 2	User-defined characters
table 3	PC437

Notes

- Use the ESC (t command to assign any registered character table to any character table.
- To copy user-defined characters (that have been created with the ESC & or ESC : commands) to the upper half of the character table, send the ESC % 0 command, followed by the ESC t 2 command. However, you cannot copy user-defined characters using ESC t 2 if you have previously assigned another character table to table 2 using the ESC (t command.

Printers not featuring this command

None

Model-dependent variations

On non-ESC/P 2 printers:

- Selects the character table to be used for printing from between the two below:
 - n = 0 Italic character table
 - 1 Graphic character table
- When n = 2, this command copies the user-defined characters from positions 0 to 127 to positions 128 to 255.

Related topics

ESC (t, Selecting the character table, Assign character tables, Switching to RAM character printing

Format

ASCII	ESC	t	n
Hex	1B	74	n
Decimal	27	116	n

Parameter range

n = 0, 1, 48, 49

Function

Selects from between the two character sets described below:

n = 0 or 48	Character table 0
1 or 49	Character table 1

Default

table 0	Italic
table 1	PC437 (US)

Notes

Use the ESC (t command to assign any registered character table to any character table.

Printers not featuring this command

None

Model-dependent variations

ActionPrinter T-750, ActionPrinter T-1000, ActionPrinter Apex 80, ActionPrinter 2000, ActionPrinter 2500, DFX-5000, DFX-8000, FX-850, FX-1050, LX-400, LX-800, LX-810, LX-850, LX-1050

Selects from between only the two character sets described below:

n = 0 or 48	Italic character table
1 or 49	Graphic character table

Related topics

ESC (+, Selecting the character table

Format

ASCII	ESC	R	n
Hex	1B	52	n
Decimal	27	82	n

Parameter range $0 \leq n \leq 13, n = 64$ **Function**

Selects the set of characters printed for specific character codes, as listed below:

n = 0	USA
1	France
2	Germany
3	United Kingdom
4	Denmark I
5	Sweden
6	Italy
7	Spain I
8	Japan (English)
9	Norway
10	Denmark II
11	Spain II
12	Latin America
13	Korea
64	Legal

Default

Depends on DIP-switch or default mode setting

Notes

The characters printed for each international character set are listed below:

n	Set name	Dec Hex	35 23	36 24	64 40	91 5B	92 5C	93 5D	94 5E	96 60	123 7B	124 7C	125 7D	126 7E
0	USA	#	\$	@	[\]	^	`	{		}	~	
1	France	#	\$	à	°	ç	§	^	`	é	ù	è	¨	
2	Germany	#	\$	§	Ä	Ö	Ü	^	`	ä	ö	ü	ß	
3	UK	£	\$	@	[\]	^	`	{		}	~	
4	Denmark I	#	\$	@	Æ	Ø	Å	^	`	æ	ø	å	~	
5	Sweden	#	¤	É	Ä	Ö	Å	Ü	é	ä	ö	å	ü	
6	Italy	#	\$	@	°	\	é	^	ù	à	ò	è	ì	
7	Spain I	Pt	\$	@	ı	Ñ	ı	^	`	¨	ñ	}	~	
8	Japan (Eng)	#	\$	@	[¥]	^	`	{		}	~	
9	Norway	#	¤	É	Æ	Ø	Å	Ü	é	æ	ø	å	ü	
10	Denmark II	#	\$	É	Æ	Ø	Å	Ü	é	æ	ø	å	ü	
11	Spain II	#	\$	á	ı	Ñ	ı	é	`	ı	ñ	ó	ú	
12	Lat America	#	\$	á	ı	Ñ	ı	é	ü	ı	ñ	ó	ú	
13	Korea	#	\$	@	[₩]	^	`	{		}	~	
64	Legal	#	\$	§	°	'	"	¶	`	©	®	†	™	

Printers not featuring this command

None

Model-dependent variations

ActionPrinter L-1000, LQ-400, LQ-500. The Legal set (n=64) and Korea set (n=13) are not available.

Related topics

Selecting an international character set

Format

ASCII	ESC	R	n
Hex	1B	52	n
Decimal	27	82	n

Parameter range

$0 \leq n \leq 13$

Function

Selects the set of characters printed for specific character codes, as listed below:

- n = 0 USA
- 1 France
- 2 Germany
- 3 United Kingdom
- 4 Denmark I
- 5 Sweden
- 6 Italy
- 7 Spain I
- 8 Japan (English)
- 9 Norway
- 10 Denmark II
- 11 Spain II
- 12 Latin America

Default

Depends on DIP-switch or default mode setting

Notes

The characters printed for each international character set are listed below:

n	Set name	Dec Hex	35 23	36 24	64 40	91 5B	92 5C	93 5D	94 5E	96 60	123 7B	124 7C	125 7D	126 7E
0	USA	#	\$	@	[\]	^	`	{		}	~	
1	France	#	\$	à	°	ç	§	^	`	é	ù	è	¨	
2	Germany	#	\$	§	Ä	Ö	Ü	^	`	ä	ö	ü	ß	
3	UK	£	\$	@	[\]	^	`	{		}	~	
4	Denmark I	#	\$	@	Æ	Ø	Å	^	`	æ	ø	å	~	
5	Sweden	#	¤	É	Ä	Ö	Å	Ü	é	ä	ö	å	ü	
6	Italy	#	\$	@	°	\	é	^	ù	à	ò	è	ì	
7	Spain I	Pt	\$	@	ı	Ñ	ı	^	`	¨	ñ	}	~	
8	Japan (Eng)	#	\$	@	[¥]	^	`	{		}	~	
9	Norway	#	¤	É	Æ	Ø	Å	Ü	é	æ	ø	å	ü	
10	Denmark II	#	\$	É	Æ	Ø	Å	Ü	é	æ	ø	å	ü	
11	Spain II	#	\$	á	ı	Ñ	ı	é	`	ı	ñ	ó	ú	
12	Lat America	#	\$	á	ı	Ñ	ı	é	ü	ı	ñ	ó	ú	

Printers not featuring this command

None

Model-dependent variations

None

Related topics

Selecting an international character set

Format

ASCII	ESC	&	NUL	n	m	[a ₀	a ₁	a ₂	d ₁	d ₂	...	d _k]
Hex	1B	26	00	n	m	[a ₀	a ₁	a ₂	d ₁	d ₂	...	d _k]
Decimal	27	38	0	n	m	[a ₀	a ₁	a ₂	d ₁	d ₂	...	d _k]

Parameter range

$$0 \leq n \leq 127$$

$$0 \leq m \leq 127$$

$$n \leq m$$

LQ mode

$$0 \leq a_1 \leq 37$$

$$0 \leq a_0 + a_1 + a_2 \leq 42$$

Draft mode

$$0 \leq a_1 \leq 15$$

$$0 \leq a_0 + a_1 + a_2 \leq 18$$

Normal characters

$$k = 3 \times a_1$$

Super/subscript characters

$$k = 2 \times a_1$$

Function

Sets the parameters for user-defined characters and then sends the data for those characters, as described below:

n	Character code of the first character to be user-defined
m	Character code of the last character to be user-defined
a ₀	Space to the left of each proportional user-defined character
a ₁	Actual width of user-defined characters
a ₂	Space to the right of each proportional user-defined character
d ₁ . . . d _k	Character data

Notes

- The data within brackets in the Format section above is repeated for each character you define.
- Defining characters when the following attributes are set results in the user-defined characters having those attributes: superscript, subscript, proportional spacing, draft mode, and LQ mode.
- Always cancel italic characters with the ESC 5 command before defining characters. After defining user-defined characters, you can italicize them by sending the ESC 4 command.
- User-defined characters with differing attributes cannot exist at the same time. For example, if normal-size user-defined characters have already been defined, and you use this command to define subscript characters, the previous normal-size characters are lost.
- Do not define continuous horizontal dots on the same row; the printer ignores the second of two continuous dots.

- The following maximum character widths are recommended.

(height · width)

Print quality	10 cpi	12 cpi	15 cpi	Proportional
Draft Normal size	24 × 12	24 × 10	24 × 8	Not Available
Draft Super/subscript	16 × 12	16 × 10	16 × 8	Not Available
LQ Normal size	24 × 36	24 × 30	24 × 24	24 × 42
LQ Super/subscript	16 × 36	16 × 30	16 × 24	16 × 42

- Send the ESC % 1 command to switch to user-defined characters.
- Use the ESC (^ command to print characters between 0 and 32.
- Send the ESC % 0 command followed by the ESC t 2 command to copy current user-defined characters to the upper half of the character table. The lower half of the character table is then normal ROM characters.

Printers not featuring this command

None

Model-dependent variations

None

Related topics

ESC %, ESC (^, ESC 6, ESC 7, ESC :, ESC t, ESC (t, Defining user-defined characters, Sending user-defined character data to printer

Format

The format for this command depends on whether you are defining draft characters or NLQ characters.

Draft:

ASCII	ESC	&	NUL	n	m	[a	d ₁	d ₂	...	d _k]
Hex	1B	26	00	n	m	[a	d ₁	d ₂	...	d _k]
Decimal	27	38	0	n	m	[a	d ₁	d ₂	...	d _k]

NLQ:

ASCII	ESC	&	NUL	n	m	0	[a	0	d ₁	d ₂	...	d _k]
Hex	1B	26	00	n	m	0	[a	0	d ₁	d ₂	...	d _k]
Decimal	27	38	0	n	m	0	[a	0	d ₁	d ₂	...	d _k]

Parameter range

Draft (FX):	Draft (LX):
0 ≤ a ≤ 255	0 ≤ a ≤ 255
0 ≤ m ≤ 255	58 ≤ m ≤ 63
0 ≤ n ≤ 255	58 ≤ n ≤ 63
m ≤ n	m ≤ n
0 ≤ d ≤ 255	0 ≤ d ≤ 255

NLQ:

0 ≤ a ≤ 12
58 ≤ m ≤ 63
58 ≤ n ≤ 63
m ≤ n
0 ≤ d ≤ 255

Function

Sets the parameters for user-defined characters and then sends the data for those characters, as described below:

n	Character code of the first character to be user-defined
m	Character code of the last character to be user-defined
a	Sets parameters for characters to be user-defined
d ₁ . . . d _k	Character data

Notes

- The data within brackets in the Format section above is repeated for each character you define.
- The format of the attribute byte “a” is different for draft and NLQ characters.

Draft

You can define characters 11-dots wide by 8-dots high. You must specify whether to define the upper or lower 8 dots of the 9 dots available. You can also specify the columns not printed on the left and right of the characters during proportional spacing. Set both these parameters with the a parameter, as described below:

Attribute byte table

Beginning Column		Ending Column		Upper/Lower 8 pins	
Column number	Value	Column number	Value	Pin group	Value
0	0	1	1	Upper 8 pins	128
1	16	2	2	Lower 8 pins	0
2	32	3	3		
3	48	4	4		
4	64	5	5		
5	80	6	6		
6	96	7	7		
7	112	8	8		
		9	9		
		10	10		
		11	11		

Add up the values for all three settings; the value for a is this total.

NLQ

The attribute byte a equals the width of the character, between 1 and 12 dot columns.

- Only NLQ characters can be defined on LX printers, ActionPrinter Apex 80, ActionPrinter 2000, ActionPrinter 2250, and ActionPrinter T-1000.
- When you switch to NLQ printing on FX printers, the printer enhances user-defined characters to appear as NLQ-mode characters.
- Defining characters during draft or NLQ mode results in the user-defined characters having the draft or NLQ attribute. You cannot define characters of different attributes at the same time; previously defined characters will be deleted.
- Always cancel italic characters with the ESC 5 command before defining characters. After defining user-defined characters, you can italicize them by sending the ESC 4 command.
- Do not define continuous dots on the same row during draft mode; the printer ignores the second of two continuous dots.
- Send the ESC % 1 command to switch to user-defined characters.
- Send the ESC I 1 command to allow you to print the characters between 128 and 159 and the non-control code characters between 0 and 31.

Printers not featuring this command

None

Model-dependent variations

All LX-series printers, ActionPrinter Apex 80, ActionPrinter T-1000, ActionPrinter 2250 and ActionPrinter 2000

Only the 6 characters between 58 and 63 can be defined.

Related topics

ESC %, ESC :, ESC I, ESC 6, ESC 7, Defining user-defined characters, Sending user-defined character data to printer

Format

ASCII	ESC	:	NUL	n	m
Hex	1B	3A	00	n	m
Decimal	27	58	0	n	m

Parameter range

$0 \leq n \leq 127$

$m = 0$

Function

Copies the data for the characters between 0 and 126 of the n typeface from ROM to RAM memory

Notes

- The following attributes are reflected in the copied font: typeface, international character set, size (super/subscript or normal), and quality (draft/LQ). Do not change any attributes before modifying characters in the copied font.
- Always cancel italics with the ESC 5 command before copying ROM characters to RAM. You can italicize characters after copying by sending the ESC 4 command.
- Sending this command clears any previous characters copied to RAM.
- The printer ignores this command if the specified typeface is not available in ROM.
- See ESC k for a list of the selectable fonts.

Printers not featuring this command

None

Model-dependent variations

- On non-ESC/P 2 printers:
- The Orator and Orator-S fonts cannot be copied.
- The Script C font is not available

Related topics

ESC %, ESC &, ESC (^, ESC x, ESC k, Copying ROM characters to RAM memory

Format

ASCII	ESC	:	NUL	n	m
Hex	1B	3A	00	n	m
Decimal	27	58	0	n	m

Parameter range

n = 0, 1

m = 0

Function

Copies the data for the characters between 0 and 255 of the Roman or Sans Serif typeface from ROM to RAM memory according to the following values:

n = 0	Roman
1	Sans serif

Notes

- Sending this command clears any previous characters copied to RAM.
- Characters from 128 to 255 are copied from the italic character table

Printers not featuring this command

None

Model-dependent variations

DFX-5000, ActionPrinter T-750

Only draft characters can be copied to RAM.

LX-series printers, ActionPrinter Apex 80, ActionPrinter T-1000, ActionPrinter 2000

Only characters from 58 to 63 can be copied to RAM.

Related topics

ESC %, ESC &, ESC x, Copying ROM characters to RAM memory

Format

ASCII	ESC	%	n
Hex	1B	25	n
Decimal	27	37	n

Parameter range

n = 0, 1, 48, 49

Function

Switches between normal and user-defined characters, as follows:

- n = 0 or 48 Normal (ROM) characters
- 1 or 49 User-defined (RAM) characters

Default

Normal (ROM) characters

Notes

Switch to ROM characters (ESC % 0) before selecting user-defined characters using the ESC t 2 command.

Printers not featuring this command

None

Model-dependent variations

None

Related topics

ESC :, ESC &, ESC t, ESC (t, Switching to RAM character printing

Format

ASCII	ESC	%	n
Hex	1B	25	n
Decimal	27	37	n

Parameter range

n = 0, 1, 48, 49

Function

Switches between normal and user-defined characters, as follows:

n = 0 or 48	Normal (ROM) characters
1 or 49	User-defined (RAM) characters

Default

Normal (ROM) characters

Printers not featuring this command

None

Model-dependent variations

FX-850 and FX-1050

Draft user-defined characters are converted to LQ characters during LQ mode.

Related topics

ESC :, ESC &, ESC 6, ESC 7, Switching to RAM character printing

Format

ASCII	ESC	x	n
Hex	1B	78	n
Decimal	27	120	n

Parameter range

n = 0, 1, 48, 49

Function

Selects either LQ or draft printing according to the following values:

n = 0 or 48	Draft printing
1 or 49	Letter-quality printing

Notes

If you select proportional spacing with the ESC p command during draft printing, the printer prints an LQ font instead. When you cancel proportional spacing with the ESC p command, the printer returns to draft printing.

Printers not featuring this command

None

Model-dependent variations

None

Related topics

ESC k, Print quality (draft, LQ, or NLQ)

Format

ASCII	ESC	x	n
Hex	1B	78	n
Decimal	27	120	n

Parameter range

n = 0, 1, 48, 49

Function

Selects either NLQ or draft printing according to the following values:

n = 0 or 48	Draft printing is selected
1 or 49	NLQ printing is selected

Notes

Double-strike printing is not possible when NLQ printing is selected

Printers not featuring this command

None

Model-dependent variations

None

Related topics

ESC k, Print quality (draft, LQ, or NLQ)

Format

ASCII	ESC	k	n
Hex	1B	6B	n
Decimal	27	107	n

Parameter range
 $0 \leq n \leq 9$
Function

Selects the typeface for LQ printing according to the following values:

0	Roman	7	Orator
1	Sans serif	8	Orator-S
2	Courier	9	Script C
3	Prestige	10	Roman T
4	Script	11	Sans serif H
5	OCR-B	30	SV Busaba
6	OCR-A	31	SV Jitra

Default

n = 0 (Roman)

Notes

- The printer ignores this command if the user-defined character set is selected.
- The Roman typeface is selected if the selected typeface is not available.
- If draft mode is selected when this command is sent, the new LQ typeface will be selected when the printer returns to LQ printing.

Printers not featuring this command

None

Model-dependent variations

Not all printers feature all typefaces; see the Command Table section for the typefaces available on each printer model.

Related topics

ESC x, ESC X, ESC %, ESC :, Selecting the typeface, Copying ROM characters to RAM memory

Format

ASCII	ESC	k	n
Hex	1B	6B	n
Decimal	27	107	n

Parameter range

n = 0, 1

Function

Selects the typeface for LQ font printing according to the following values:

0	Roman
1	Sans serif

Default

n = 0 (Roman)

Notes

- The printer ignores this command if the user-defined character set is selected.
- If draft mode is selected when this command is sent, the new typeface will be selected when the printer returns to LQ printing.

Printers not featuring this command

None

Model-dependent variations

None

Related topics

ESC x, ESC %, ESC :, Selecting the typeface, Copying ROM characters to RAM

Format

ASCII	ESC	X	m	n _L	n _H
Hex	1B	58	m	n _L	n _H
Decimal	27	88	m	n _L	n _H

Parameter range

$$5 \leq m \leq 127 \quad m = 0, 1$$

$$0 \leq n_L \leq 255$$

$$0 \leq n_H \leq 127$$

Function

Puts the printer in multipoint (scalable font) mode, and selects the pitch and point attributes of the font according to the following formulas:

Pitch:

m = 0	No change in pitch
m = 1	Selects proportional spacing
m ≥ 5	Selects fixed pitch equal to 360/m cpi

Point size:

$$(\text{point size}) = \frac{(n_H \times 256) + n_L}{2} \quad 1 \text{ point equals } 1/72 \text{ inch}$$

$$n_H = \text{INT} \frac{(\text{point size}) \times 2}{256}$$

$$n_L = \text{MOD} \frac{(\text{point size}) \times 2}{256}$$

n_H = n_L = 0 No change in point size

Default

Pitch = 10 cpi (m = 36)

Point = 10.5 (n_H = 0, n_L = 21)

Notes

- This command is available only on printers featuring ESC/P 2.
- This command overrides the current pitch setting.
- Only the following point sizes are available: 8, 10 (10.5), 12, 14, 16, 18, 20 (21), 22, 24, 26, 28, 30, 32
- Selecting a combination of 15 cpi and 10 or 20-point characters results in 15-cpi ROM characters being chosen; the height of these characters is about 2/3 that of normal characters. Select the pitch with the ESC C command to obtain normal height 10 or 20-point characters at 15 cpi.

- During multipoint mode the printer ignores the ESC W, ESC w, ESC SP, SI, ESC SI, SO, and ESC SO commands.
- The following commands cancel multipoint mode, returning the printer to 10.5-point characters: ESC P, ESC M, ESC g, ESC p, ESC !, and ESC @.

Printers not featuring this command

All non-ESC/P 2 printers

Model-dependent variations

Not all fonts are scalable; see the Command Table section for details on which fonts are scalable on each printer model.

Related topics

ESC c, ESC P, ESC M, ESC g, ESC p, ESC !, Selecting the point size, Selecting the pitch

Format

ASCII	ESC	c	n _L	n _H
Hex	1B	63	n _L	n _H
Decimal	27	99	n _L	n _H

Parameter range

$$0 \leq n_H \leq 4$$

$$0 \leq n_L \leq 255$$

$$0 < ((n_H \times 256) + n_L) \leq 1080 ; \text{HMI} \leq 3.00 \text{ inches}$$

Function

Fixes the character width (HMI) according to the following formula:

$$\text{HMI} = \frac{(n_H \times 256) + n_L}{360} \text{ inch}$$

$$n_H = \text{INT} \frac{\text{HMI} \times 360}{256}$$

$$n_L = \text{MOD} \frac{\text{HMI} \times 360}{256}$$

Default

Depends on panel or DIP-switch setting

Notes

- This command is available only on printers featuring ESC/P 2.
- This command cancels additional character space set with the ESC SP command.
- The HMI setting made with this command is canceled when the printer receives the following commands: SO, SI, DC2, DC4, ESC W, ESC P, ESC M, ESC g, ESC p, ESC !, ESC SP, and ESC @.
- Use this command to set the pitch if you want to print normal-height 10 or 20-point characters at 15 cpi during multipoint mode. Selecting 15 cpi for 10 or 20-point characters with the ESC X command results in characters being printed at 2/3 their normal height.

Printers not featuring this command

All non-ESC/P 2 printers

Model-dependent variations

None

Related topics

ESC X, ESC P, ESC M, ESC g, ESC p, ESC !, Selecting the pitch

Format

ASCII	ESC	P
Hex	1B	50
Decimal	27	80

Function

Selects 10.5-point, 10-cpi character printing

Default

10.5-point, 10-cpi characters

Notes

- This command cancels the HMI set with the ESC c command.
- This command cancels multipoint mode.
- If you change the pitch with this command during proportional mode (selected with the ESC p command), the change takes effect when the printer exits proportional mode.

Printers not featuring this command

None

Model-dependent variations

None

Related topics

ESC M, ESC g, ESC p, ESC X, ESC c, ESC !, Selecting the pitch

Format

ASCII	ESC	P
Hex	1B	50
Decimal	27	80

Function

Selects 10-cpi character pitch

Default

10-cpi characters

Notes

If you change the fixed-pitch setting with this command during proportional mode (selected with the ESC p command), the change takes effect when the printer exits proportional mode.

Printers not featuring this command

None

Model-dependent variations

None

Related topics

ESC M, ESC p, ESC !, Selecting the pitch

Format

ASCII	ESC	M
Hex	1B	4D
Decimal	27	77

Function

Selects 10.5-point, 12-cpi character printing

Default

10.5-point, 10-cpi characters

Notes

- This command cancels the HMI set with the ESC c command.
- This command cancels multipoint mode.
- If you change the pitch with this command during proportional mode (selected with the ESC p command), the change takes effect when the printer exits proportional mode.

Printers not featuring this command

None

Model-dependent variations

None

Related topics

ESC P, ESC g, ESC p, ESC X, ESC c, ESC !, Selecting the pitch

Format

ASCII	ESC	M
Hex	1B	4D
Decimal	27	77

Function

Selects 12-cpi character pitch

Default

10-cpi characters

Notes

If you change the pitch with this command during proportional mode (selected with the ESC p command), the change takes effect when the printer exits proportional mode.

Printers not featuring this command

None

Model-dependent variations

None

Related topics

ESC P, ESC p, ESC l, Selecting the pitch

Format

ASCII	ESC	g
Hex	1B	67
Decimal	27	103

Function

Selects 10.5-point, 15-cpi character printing

Default

10.5-point, 10-cpi characters

Notes

- This command cancels the HMI set with the ESC c command.
- This command cancels multipoint mode.
- If you change the pitch with this command during proportional mode (selected with the ESC p command), the change takes effect when the printer exits proportional mode.

Printers not featuring this command

None

Model-dependent variations

None

Related topics

ESC M, ESC P, ESC p, ESC c, ESC X, Selecting the pitch

Format

ASCII	ESC	g
Hex	1B	67
Decimal	27	103

Function

Selects 15-cpi character printing

Default

10-cpi characters

Notes

If you change the fixed-pitch setting with this command during proportional mode (selected with the ESC p command), the change takes effect when the printer exits proportional mode.

Printers featuring this command

FX-2170, DFX-5000+

Model-dependent variations

None

Related topics

ESC M, ESC P, ESC p, ESC !, Selecting the pitch

Format

ASCII	ESC	p	n
Hex	1B	70	n
Decimal	27	112	n

Parameter range

n = 0, 1, 48, 49

Function

Selects either proportional or fixed character spacing according to the following values:

n = 0 or 48	Returns to current fixed character pitch
1 or 49	Selects proportional spacing

Default

Fixed character spacing

Notes

- This command cancels the HMI set with the ESC c command.
- This command cancels multipoint mode.
- Changes made to the fixed-pitch setting with the ESC P, ESC M, or ESC g commands during proportional mode take effect when the printer exits proportional mode.
- The printer automatically switches to LQ printing when proportional spacing is selected.

Printers not featuring this command

None

Model-dependent variations

None

Related topics

ESC M, ESC P, ESC g, ESC !, ESC X, ESC c, Selecting the pitch

Format

ASCII	ESC	p	n
Hex	1B	70	n
Decimal	27	112	n

Parameter range

n = 0, 1, 48, 49

Function

Selects either proportional or fixed character spacing according to the following values:

n = 0 or 48	Returns to current fixed character pitch
1 or 49	Selects proportional character spacing

Default

Fixed character spacing

Notes

- Changes made to the fixed-pitch setting with the ESC P, ESC M, or ESC g commands during proportional mode take effect when the printer exits proportional mode.
- Condensed mode is not available when proportional spacing is selected.

Printers not featuring this command

ActionPrinter Apex 80, ActionPrinter T-1000, ActionPrinter 2000, LX-400, LX-800, LX-810, LX-850, LX-1050

Model-dependent variations

None

Related topics

ESC M, ESC P, ESC !, Selecting the pitch

Format

ASCII	ESC	SP	n
Hex	1B	20	n
Decimal	27	32	n

Parameter range $0 \leq n \leq 127$ **Function**

Increases the space between characters by $n/180$ inch in LQ mode and $n/120$ inch in draft mode

Default

No extra space

Notes

- This command cancels the HMI (horizontal motion unit) set with the ESC c command.
- The extra space set with this command doubles during double-width mode.

Printers not featuring this command

None

Model-dependent variations

None

Related topics

ESC c, ESC M, ESC P, ESC g, ESC !, ESC I, ESC Q, ESC D, HT, Selecting the pitch, Setting left and right margins

Format

ASCII	ESC	SP	n
Hex	1B	20	n
Decimal	27	32	n

Parameter range

$0 \leq n \leq 127$

Function

Increases the space between characters by $n/120$ inch

Default

No extra space

Notes

The extra space set with this command doubles during double-width mode.

Printers not featuring this command

LX-series printers, ActionPrinter Apex 80, ActionPrinter T-1000, ActionPrinter 2000

Model-dependent variations

None

Related topics

ESC M, ESC P, ESC !, ESC I, ESC Q, ESC D, HT, Selecting the pitch, Setting left and right margins

Format

ASCII	ESC	E
Hex	1B	45
Decimal	27	69

Function

Sets the weight attribute of the font to bold

Default

Normal (nonbold) weight

Notes

This command increases the weight of printed lines and characters, resulting in bolder printing.

Printers not featuring this command

None

Model-dependent variations

None

Related topics

ESC F, ESC G, ESC H, Select a font, Selecting the weight

Format

ASCII	ESC	E
Hex	1B	45
Decimal	27	69

Function

Sets the weight attribute of the font to bold

Default

Normal (nonbold) weight

Notes

This command increases the weight of printed lines and characters, resulting in bolder printing.

Printers not featuring this command

None

Model-dependent variations

None

Related topics

ESC F, ESC G, ESC H, Select a font, Selecting the weight

Format

ASCII	ESC	F
Hex	1B	46
Decimal	27	70

Function

Sets the weight attribute of the font to normal (cancels the bold weight previously set with the ESC E command)

Default

Normal (nonbold) weight

Printers not featuring this command

None

Model-dependent variations

None

Related topics

ESC E, ESC G, ESC H, Select a font, Selecting the weight

Format

ASCII	ESC	F
Hex	1B	46
Decimal	27	70

Function

Sets the weight attribute of the font to normal (cancels the bold weight previously set with the ESC E command)

Default

Normal (nonbold) weight

Printers not featuring this command

None

Model-dependent variations

None

Related topics

ESC E, ESC G, ESC H, Select a font, Selecting the weight

Format

ASCII	ESC	4
Hex	1B	34
Decimal	27	52

Function

Sets the style attribute of the font to italic

Default

Normal (non-italic) style

Notes

- This command selects italic printing even if the italic character table is not selected.
- Always cancel italics before defining user-defined characters.

Printers not featuring this command

None

Model-dependent variations

None

Related topics

ESC 5, Select a font, Selecting the style

Format

ASCII	ESC	4
Hex	1B	34
Decimal	27	52

Function

Sets the style attribute of the font to italic

Default

Normal (non-italic) style

Notes

- This command selects italic printing even if the italic character table is not selected.
- Always cancel italics before defining user-defined characters.

Printers not featuring this command

None

Model-dependent variations

None

Related topics

ESC 5, Select a font, Selecting the style

Format

ASCII	ESC	5
Hex	1B	35
Decimal	27	53

Function

Sets the style attribute of the font to normal (cancels the italic style attribute previously selected with the ESC 4 command)

Default

Normal (non-italic) style

Notes

Always cancel italics before defining user-defined characters.

Printers not featuring this command

None

Model-dependent variations

None

Related topics

ESC 4, Select a font, Selecting the style

Format

ASCII	ESC	5
Hex	1B	35
Decimal	27	53

Function

Sets the style attribute of the font to normal (cancels the italic style attribute previously selected with the ESC 4 command)

Default

Normal (non-italic) style

Notes

Always cancel italics before defining user-defined characters.

Printers not featuring this command

None

Model-dependent variations

None

Related topics

ESC 4, Select a font, Selecting the style

Format

ASCII	ESC	!	n
Hex	1B	21	n
Decimal	27	33	n

Parameter range
 $0 \leq n \leq 255$
Function

Selects any combination of several font attributes and enhancements by setting or clearing the appropriate bit in the n parameter, as shown below:

Bit	On/Off	Hex	Dec	Function	Equivalent
0	Off	00	0	Selects 10 cpi	ESC P
	On	01	1	Selects 12 cpi	ESC M
1	Off	00	0	Cancel proportional	ESC p 0
	On	02	2	Selects proportional	ESC p 1
2	Off	00	0	Cancel condensed	DC2
	On	04	4	Selects condensed	SI
3	Off	00	0	Cancel bold	ESC F
	On	08	8	Selects bold	ESC E
4	Off	00	0	Cancel double-strike	ESC H
	On	10	16	Selects double-strike	ESC G
5	Off	00	0	Cancel double-width	ESC W 0
	On	20	32	Selects double-width	ESC W 1
6	Off	00	0	Cancel italics	ESC 5
	On	40	64	Selects italics	ESC 4
7	Off	00	0	Cancel underline	ESC - 0
	On	80	128	Selects underline	ESC - 1

Add the numbers of the features to be selected and send the total as the parameter n.

Notes

- This command cancels multipoint mode.
- This command cancels the HMI selected with the ESC c command.
- This command cancels any attributes or enhancements that are not selected.
- All attributes or enhancements may not be available on some models. For details, see the explanation for the equivalent command listed in the table above.

Printers not featuring this command

None

Model-dependent variations

None

Related topics

ESC X, ESC c, Select a font

Format

ASCII	ESC	!	n
Hex	1B	21	n
Decimal	27	33	n

Parameter range

$$0 \leq n \leq 255$$

Function

Selects any combination of several font attributes and enhancements by setting or clearing the appropriate bit in the n parameter, as shown below:

Bit	On/Off	Hex	Dec	Function	Equivalent
0	Off	00	0	Selects 10 cpi	ESC P
	On	01	1	Selects 12 cpi	ESC M
1	Off	00	0	Cancel proportional	ESC p 0
	On	02	2	Selects proportional	ESC p 1
2	Off	00	0	Cancel condensed	DC2
	On	04	4	Selects condensed	ESC SI, SI
3	Off	00	0	Cancel bold	ESC F
	On	08	8	Selects bold	ESC E
4	Off	00	0	Cancel double-strike	ESC H
	On	10	16	Selects double-strike	ESC G
5	Off	00	0	Cancel double-width	ESC W 0
	On	20	32	Selects double-width	ESC W 1
6	Off	00	0	Cancel italics	ESC 5
	On	40	64	Selects italics	ESC 4
7	Off	00	0	Cancel underline	ESC - 0
	On	80	128	Selects underline	ESC - 1

Add the numbers of the features to be selected and send the total as the parameter n.

Notes

- This command cancels any attributes or enhancements that are not selected.
- All attributes or enhancements may not be available on some models. For details, see the command explanation for the equivalent command listed in the above table.

Printers not featuring this command

None

Model-dependent variations

None

Related topics

Select a font

Format

ASCII	ESC	G
Hex	1B	47
Decimal	27	71

Function

Prints each dot twice, with the second slightly below the first, creating bolder characters

Default

Normal (nondouble-strike) printing

Printers not featuring this command

None

Model-dependent variations

None

Related topics

ESC H, ESC E, ESC F, Double-strike

Format

ASCII	ESC	G
Hex	1B	47
Decimal	27	71

Function

Prints each dot twice, with the second slightly below the first, creating bolder characters

Default

Normal (nondouble-strike) printing

Notes

LQ mode overrides double-strike printing; double-strike printing resumes when LQ mode is canceled.

Printers not featuring this command

None

Model-dependent variations

None

Related topics

ESC H, ESC E, ESC F, Double-strike

Format

ASCII	ESC	H
Hex	1B	48
Decimal	27	72

Function

 Cancels double-strike printing selected with the ESC G command

Default

 Normal (nondouble-strike) printing

Printers not featuring this command

 None

Model-dependent variations

 None

Related topics

 ESC G, ESC E, ESC F, Double-strike

Format

ASCII	ESC	H
Hex	1B	48
Decimal	27	72

Function

 Cancels double-strike printing selected with the ESC G command

Default

 Normal (nondouble-strike) printing

Printers not featuring this command

 None

Model-dependent variations

 None

Related topics

 ESC G, ESC E, ESC F, Double-strike

Format

ASCII	ESC	-	n
Hex	1B	2D	n
Decimal	27	45	n

Parameter range

n = 0, 1, 48, 49

Function

Turns on/off printing of a line below all characters and spaces following this command:

n = 1 or 49	Turns underline on
0 or 48	Turns underline off

Default

Normal (non-underlined) printing

Notes

- The underline is printed with the following characteristics: draft, LQ, bold, or double-strike.
- The underline is not printed across the distance the horizontal print position is moved with the following commands:
 - ESC \$
 - ESC \ (when the print position is moved to the left)
 - HT
- Graphics characters are not underlined.

Printers not featuring this command

None

Model-dependent variations

None

Related topics

ESC (-, Score

Format

ASCII	ESC	-	n
Hex	1B	2D	n
Decimal	27	45	n

Parameter range

n = 0, 1, 48, 49

Function

Turns on/off printing of a line below all characters and spaces following this command:

n = 1 or 49	Turns on underline
0 or 48	Turns off underline

Default

Normal (non-underlined) printing

Notes

- The underline is printed with the following characteristics: draft, LQ, bold, or double-strike.
- The underline is not printed across the distance the horizontal print position is moved with the following commands:
ESC \$
ESC \ (when the print position is moved to the left)
HT
- Graphics characters are not underlined.

Printers not featuring this command

None

Model-dependent variations

None

Related topics

Score

Format

ASCII	ESC	(-	n _L	n _H	m	d1	d2
Hex	1B	28	2D	n _L	n _H	m	d1	d2
Decimal	27	40	45	n _L	n _H	m	d1	d2

Parameter range

n_L = 3, n_H = 0
 m = 1
 1 ≤ d₁ ≤ 3
 d₂ = 0, 1, 2, 5, 6

Function

Turns on/off scoring of all characters and spaces following this command, according to the parameters below:

d ₁ = 1	Underline
2	Strikethrough
3	Overscore
d ₂ = 0	Turn off scoring
1	Single continuous line
2	Double continuous line
5	Single broken line
6	Double broken line

Default

No scoring

Notes

- This command is only available on 24 and 48-pin printers.
- Each type of scoring is independent of other types; any combination of scoring methods may be set simultaneously.
- The position and thickness of scoring depends on the current point size setting.
- The score is printed with the following characteristics: draft, LQ, bold, or double- strike.
- Graphics characters are not scored.
- Scoring is not printed across the distance the horizontal print position is moved with the following commands:
 ESC \$
 ESC \ (when the print position is moved to the left)
 HT

Printers not featuring this command

ActionPrinter L-1000, LQ-400, LQ-500, LQ-2550

Model-dependent variations

None

Related topics

ESC -, Score

Format

ASCII	ESC	S	n
Hex	1B	53	n
Decimal	27	83	n

Parameter range

n = 0, 1, 48, 49

Function

Prints characters that follow at about 2/3 their normal height; the printing location depends on the value of n as follows:

n = 1 or 49	Lower part of the character space
0 or 48	Upper part of the character space

Default

Normal (non-super/subscript) characters

Notes

- This command does not affect graphics characters.
- The width of super/subscript characters when using proportional spacing differs from that of normal characters; see the super/subscript character proportional width table in the Appendix.
- The underline strikes through the descenders on subscript characters during underlining.
- Use the ESC T command to cancel super/subscript printing.
- When point sizes other than 10 (10.5) and 20 (21) are selected in multipoint mode, super/subscript characters are printed at the nearest point size less than or equal to 2/3 the current size.
- When 8-point characters are selected, super/subscript characters are also 8-point characters.

Printers not featuring this command

None

Model-dependent variations

None

Related topics

ESC T, Super/subscript

Format

ASCII	ESC	S	n
Hex	1B	53	n
Decimal	27	83	n

Parameter range

n = 0, 1, 48, 49

Function

Prints characters that follow at about 2/3 their normal height; the printing location depends on the value of n as follows:

n = 1 or 49	Lower part of the character space
0 or 48	Upper part of the character space

Default

Normal (non-super/subscript) characters

Notes

- This command does not affect graphics characters.
- The width of super/subscript characters when using proportional spacing is the same as that of normal characters.
- The underline strikes through the descenders on subscript characters during underline mode.
- Use the ESC T command to cancel super/subscript printing.

Printers not featuring this command

None

Model-dependent variations

FX-850, FX-1050

Selecting double-height printing overrides super/subscript printing; super/subscript printing resumes when double-height printing is canceled.

Related topics

ESC T, Super/subscript

Format

ASCII	ESC	T
Hex	1B	54
Decimal	27	84

Function

Cancels super/subscript printing selected by the ESC S command

Default

Normal (non-super/subscript) printing

Printers not featuring this command

None

Model-dependent variations

None

Related topics

ESC S, Super/subscript

Format

ASCII	ESC	T
Hex	1B	54
Decimal	27	84

Function

 Cancels super/subscript printing selected by the ESC S command

Default

 Normal (non-super/subscript) printing

Printers not featuring this command

 None

Model-dependent variations

 None

Related topics

 ESC S, Super/subscript

Format

ASCII	ESC	q	n
Hex	1B	71	n
Decimal	27	113	n

Parameter range

$$0 \leq n \leq 3$$

Function

Turns on/off outline and shadow printing, according to the parameters below:

- n = 0 Turn off outline/shadow printing
- 1 Turn on outline printing
- 2 Turn on shadow printing
- 3 Turn on outline and shadow printing

Default

Outline/shadow printing off

Notes

- This command is available only on 24 and 48-pin printers.
- This command does not affect graphics characters.

Printers not featuring this command

None

Model-dependent variations

None

Related topics

Shadow/outline

Format

ASCII	SI
Hex	0F
Decimal	15

Function

Enters condensed mode, in which character width is reduced as follows:

Selected pitch	Condensed pitch
10 cpi	17.14 cpi
12 cpi	20 cpi
Proportional	1/2 width

Default

Noncondensed printing

Notes

- This command is ignored under the following two conditions:
 - The printer is in multipoint mode.
 - 15-cpi printing has been selected with the ESC g command.
- This command cancels the HMI (horizontal motion index) set with the ESC c command.
- This command reduces character width by about 50% when proportional spacing is selected with the ESC p command.
- Cancel condensed printing with the DC2 command.

Printers not featuring this command

None

Model-dependent variations

None

Related topics

DC2, Selecting the pitch

Format

ASCII	SI
Hex	0F
Decimal	15

Function

Enters condensed mode, in which character width is reduced as follows:

Selected pitch	Condensed pitch
10 cpi	17.14 cpi
12 cpi	20 cpi

Default

Noncondensed printing

Notes

Cancel condensed printing with the DC2 command.

Printers not featuring this command

None

Model-dependent variations

None

Related topics

DC2, Selecting the pitch

Format

ASCII	ESC	SI
Hex	1B	0F
Decimal	27	15

Function

Enters condensed mode, in which character width is reduced as follows:

Selected pitch	Condensed pitch
10 cpi	17.14 cpi
12 cpi	20 cpi
Proportional	1/2 width

Default

Noncondensed printing

Notes

- This is a nonrecommended command; use the SI command instead.
- This command is ignored under the following two conditions:
 - The printer is in multipoint mode.
 - 15-cpi printing has been selected with the ESC g command.
- This command cancels the HMI (horizontal motion index) set with the ESC c command.
- This command reduces character width by about 50% when proportional spacing is selected with the ESC p command.
- Cancel condensed printing with the DC2 command.

Printers not featuring this command

None

Model-dependent variations

None

Related topics

DC2, SI, Selecting the pitch

Format

ASCII	ESC	SI
Hex	1B	0F
Decimal	27	15

Parameter range

No parameters

Function

Enters condensed mode, in which characters width is reduced as follows:

Selected pitch	Condensed pitch
10 cpi	17.14 cpi
12 cpi	20 cpi

Default

Noncondensed printing

Notes

- This is a nonrecommended command; use the SI command instead.
- Cancel condensed printing with the DC2 command.

Printers not featuring this command

None

Model-dependent variations

None

Related topics

SI, DC2, Selecting the pitch

Format

ASCII	DC2
Hex	12
Decimal	18

Function

Cancels condensed printing selected by the SI or ESC SI commands

Default

Normal (noncondensed) printing

Notes

This command cancels the HMI (horizontal motion index) set with the ESC c command.

Printers not featuring this command

None

Model-dependent variations

None

Related topics

SI

Format

ASCII	DC2
Hex	12
Decimal	18

Function

Cancels condensed printing selected by the SI or ESC SI commands

Default

Normal (noncondensed) printing

Printers not featuring this command

None

Model-dependent variations

None

Related topics

SI

Format

ASCII	SO
Hex	0E
Decimal	14

Function

Doubles the width of all characters, spaces, and intercharacter spacing (set with the ESC SP command) following this command on the same line.

Default

Normal (nondouble-width) printing

Notes

- This command is canceled when the buffer is full, or the printer receives the following commands: LF, FF, VT, DC4, ESC W 0.
- This command is not canceled by the VT command when it functions the same as a CR command.
- This command cancels the HMI (horizontal motion index) set with the ESC c command.

Printers not featuring this command

None

Model-dependent variations

On non-ESC/P 2 printers:

This command is also canceled when the printer receives the following commands: CR and VT (when it functions the same as a CR command).

Related topics

ESC W, DC4

Format

ASCII	SO
Hex	0E
Decimal	14

Function

Doubles the width of all characters, spaces, and intercharacter spacing (set with the ESC SP command) following this command on the same line.

Default

Normal (nondouble-width) printing

Notes

This command is canceled when the buffer is full, or the printer receives the following commands: CR, LF, FF, VT, DC4, ESC W 0.

Printers not featuring this command

None

Model-dependent variations

None

Related topics

ESC W, DC4

Format

ASCII	ESC	SO
Hex	1B	0E
Decimal	27	14

Function

Doubles the width of all characters, spaces, and intercharacter spacing (set with the ESC SP command) following this command on the same line.

Default

Normal (nondouble-width) printing

Notes

- This is a nonrecommended command; use the SO command instead.
- This command is canceled when the buffer is full, or the printer receives the following commands: LF, FF, VT, DC4, ESC W 0.
- This command is not canceled by the VT command when it functions the same as a CR command.
- This command cancels the HMI (horizontal motion index) set with the ESC c command.

Printers not featuring this command

None

Model-dependent variations

On non-ESC/P 2 printers:

This command is also canceled when the printer receives the following commands: CR and VT (when it functions the same as a CR command).

Related topics

SO, DC4

Format

ASCII	ESC	SO
Hex	1B	0E
Decimal	27	14

Function

Doubles the width of all characters, spaces, and intercharacter spacing (set with the ESC SP command) following this command on the same line

Default

Normal (nondouble-width) printing

Notes

- This is a nonrecommended command; use the SO command instead.
- This command is canceled when the buffer is full, or the printer receives the following commands: CR, LF, FF, VT, DC4, ESC W 0.

Printers not featuring this command

None

Model-dependent variations

None

Related topics

SO, DC4, ESC W

Format

ASCII	DC4
Hex	14
Decimal	20

Parameter range

No parameters

Function

Cancels double-width printing selected by the SO or ESC SO commands

Default

Normal (nondouble-width)

Notes

- This command cancels the HMI (horizontal motion index) set with the ESC c command.
- This command does not cancel double-width printing selected with the ESC W command.

Printers not featuring this command

None

Model-dependent variations

None

Related topics

SO

Format

ASCII	DC4
Hex	14
Decimal	20

Function

 Cancels double-width printing selected by the SO or ESC SO commands.

Default

 Normal (nondouble-width) printing

Notes

 This command does not cancel double-width printing selected with the ESC W command.

Printers not featuring this command

 None

Model-dependent variations

 None

Related topics

 SO

Format

ASCII	ESC	W	n
Hex	1B	57	n
Decimal	27	87	n

Parameter range

n = 0, 1, 48, 49

Function

Turns on/off double-width printing of all characters, spaces, and intercharacter spacing (set with the ESC SP command) following this command as follows:

n = 1 or 49	Turns on double-width
0 or 48	Turns off double-width

Default

Normal (nondouble-width) printing

Notes

This command cancels the HMI (horizontal motion index) set with the ESC c command.

Printers not featuring this command

None

Model-dependent variations

None

Related topics

SO, DC4

Format

ASCII	ESC	W	n
Hex	1B	57	n
Decimal	27	87	n

Parameter range

n = 0, 1, 48, 49

Function

Turns on/off double-width printing of all characters, spaces, and intercharacter spacing (set with the ESC SP command) following this command as follows:

- n = 1 or 49 Turns on double-width
- 0 or 48 Turns off double-width

Default

Normal (nondouble-width) printing

Printers not featuring this command

None

Model-dependent variations

None

Related topics

SO, DC4

Format

ASCII	ESC	w	n
Hex	1B	77	n
Decimal	27	119	n

Parameter range

n = 0, 1, 48, 49

Function

Turns on/off double-height printing of all characters, as measured from the current baseline:

n = 1 or 49	Turns on double-width
0 or 48	Turns off double-width

Default

Standard-height printing

Notes

- This command does not affect line spacing.
- The first line of a page is not doubled if ESC w is sent on the first printable line; all following lines are printed at double-height.

Printers not featuring this command

None

Model-dependent variations

None

Related topics

Selecting the point size

Format

ASCII	ESC	w	n
Hex	1B	77	n
Decimal	27	119	n

Parameter range

n = 0, 1, 48, 49

Function

Turns on/off double-height printing of all characters, as measured from the current baseline:

n = 1 or 49	Turns on double-width
0 or 48	Turns off double-width

Default

Standard-height printing

Notes

- This command does not affect line spacing.
- The first line of a page is not doubled if the ESC w command is sent on the first line; all following lines are printed at double-height.
- Double-height printing overrides super/subscript, condensed, and high-speed draft printing; super/subscript, condensed, and high-speed draft printing resume when double-height printing is canceled.

Printers not featuring this command

ActionPrinter Apex 80, ActionPrinter T-1000, DFX-5000, DFX-5000+, LX-Series printers

Model-dependent variations

None

Related topics

Selecting the point size

Format

ASCII	ESC	(^	n _L	n _H	d ₁	...	d _k
Hex	1B	28	5E	n _L	n _H	d ₁	...	d _k
Decimal	27	40	94	n _L	n _H	d ₁	...	d _k

Parameter range

$$0 \leq n_H \leq 127$$

$$0 \leq n_L \leq 255$$

Function

- Prints data bytes d₁ through d_k as characters, not control codes
- The amount of data to be sent is calculated as follows:

$$k = ((n_H \times 256) + n_L)$$

$$n_H = \text{INT} \frac{k}{256}$$

$$n_L = \text{MOD} \frac{k}{256}$$

Default

Control-code data treated as control codes

Notes

- This command is available only on printers featuring ESC/P 2.
- The printer ignores data if no character is assigned to that character code in the currently selected character table.

Printers not featuring this command

All non-ESC/P 2 printers

Model-dependent variations

None

Related topics

ESC 6, ESC 7

Format

ASCII	ESC	6
Hex	1B	36
Decimal	27	54

Function

Tells the printer to treat codes from 128 to 159 as printable characters instead of control codes

Default

Codes 128 to 159 are treated as printable characters

Notes

- This command has no effect when the italic character table is selected; no characters are defined for these codes in the italic character table.
- This command remains in effect even if you change the character table.

Printers not featuring this command

None

Model-dependent variations

None

Related topics

ESC (^, ESC 7

Format

ASCII	ESC	6
Hex	1B	36
Decimal	27	54

Function

Tells the printer to treat codes from 128 to 159 as printable characters instead of control codes

Default

Codes 128 to 159 are treated as control codes

Notes

- This command has no effect when the italic character table is selected; no characters are defined for these codes in the italic character table.
- This command remains in effect even if you change the character table.

Printers not featuring this command

None

Model-dependent variations

None

Related topics

ESC I, ESC 7

Format

ASCII	ESC	7
Hex	1B	37
Decimal	27	55

Function

Tells the printer to treat codes from 128 to 159 as control codes instead of printable characters

Default

Codes 128 to 159 are treated as printable codes

Notes

This command remains in effect even if you change the character table.

Printers not featuring this command

None

Model-dependent variations

None

Related topics

ESC (^, ESC 6

Format

ASCII	ESC	7
Hex	1B	37
Decimal	27	55

Function

Tells the printer to treat codes from 128 to 159 as control codes instead of printable characters

Default

Codes 128 to 159 are treated as control codes

Notes

This command remains in effect even if you change the character table.

Printers not featuring this command

None

Model-dependent variations

None

Related topics

ESC 6, ESC I

Format

ASCII	ESC	I	n
Hex	1B	49	n
Decimal	27	73	n

Parameter range

n = 0, 1

Function

- | | |
|-------|---|
| n = 1 | Tells the printer to treat codes 0–6, 16, 17, 21–23, 25, 26, 28–31, and 128–159 as printable characters |
| 0 | Tells the printer to treat these codes as unprintable characters |

Default

Codes are treated as control codes

Notes

- This command has no effect when the italic character table is selected; no characters are defined for these codes in the italic character table.
- This command remains in effect even if you change the character table.

Printers not featuring this command

ActionPrinter Apex 80, ActionPrinter T-1000, ActionPrinter 2000, ActionPrinter 2250, LX-Series printers

Model-dependent variations

None

Related topics

ESC 6, ESC 7

Format

ASCII	ESC	m	n
Hex	1B	6D	n
Decimal	27	109	n

Parameter range

n = 0, 4

Function

Selects between the following:

- n = 0 Tells the printer to treat codes from 128 to 159 as printable characters
- 4 Tells the printer to treat codes from 128 to 159 as control codes

Default

Codes 128 to 159 treated as control codes

Notes

- This is a nonrecommended command; use the ESC I, ESC 6, or ESC 7 commands instead, when possible.
- This command has no effect when the italic character table is selected; no characters are defined for these codes in the italic character table.
- This command remains in effect even if you change the character table.

Printers not featuring this command

ActionPrinter 2000, ActionPrinter 2250, ActionPrinter 2500, DFX-5000, DFX-5000+, DFX-8000, FX-850, FX-870, FX-1050, FX-1070, LX-100, LX-300, LX-800, LX-810, LX-850, LX-1050, LX-1050+

Model-dependent variations

None

Related topics

ESC 6, ESC 7, ESC I

Format

ASCII	ESC	EM	n
Hex	1B	19	n
Decimal	27	25	n

Parameter range

n = 49, 50, 66, 70, 82

Function

Controls feeding of continuous and single-sheet paper, according to the parameters below:

n = 49	“1”	Selects loading from bin 1 of the cut-sheet feeder
50	“2”	Selects loading from bin 2 of the cut-sheet feeder
66	“B”	Loads paper from the rear tractor
70	“F”	Loads paper from the front tractor
82	“R”	Ejects one sheet of single-sheet paper

Notes

- This command was formerly known as “Control cut-sheet feeder.”
- The former parameters “0” and “4” that control cut-sheet feeder mode are non-recommended, and have been discontinued in ESC/P 2. ESC/P 2 printers do not have a separate cut-sheet feeder mode; the former cut-sheet feeder mode is now integrated into normal printer operation.
- The parameter “R” ejects the currently loaded single-sheet paper without printing data from the line buffer; this is not the equivalent of the FF command (which does print line-buffer data).

Printers not featuring this command

None

Model-dependent variations

On non-ESC/P 2 printers:

- Only use this command when a cut-sheet feeder is installed.
- The following additional parameters are available:

n = 48	“0”	Exits cut-sheet feeder mode
52	“4”	Enters cut-sheet feeder mode
- However, these parameters are nonrecommended; cut-sheet feeder mode should be selected by DIP switch instead.

Related topics

Set the Printing Area

Format

ASCII	ESC	EM	n
Hex	1B	19	n
Decimal	27	25	n

Parameter range

n = 48, 49, 50, 52, 66, 70, 82

Function

Controls feeding of continuous and single-sheet paper, according to the parameters below:

n = 48	“0”	Exits cut-sheet feeder mode
49	“1”	Selects loading from bin 1 of the cut-sheet feeder
50	“2”	Selects loading from bin 2 of the cut-sheet feeder
52	“4”	Enters cut-sheet feeder mode
66	“B”	Loads paper from the rear tractor
70	“F”	Loads paper from the front tractor
82	“R”	Ejects one sheet of single-sheet paper

Notes

- This command was formerly known as “Control cut-sheet feeder.”
- The parameters “0” and “4” that control cut-sheet feeder mode are nonrecommended; cut-sheet feeder mode should be selected by DIP switch instead.

Printers not featuring this command

DFX-5000, DFX-5000+

Model-dependent variations

None

Related topics

Set the Printing Area

Format

ASCII	ESC	U	n
Hex	1B	55	n
Decimal	27	85	n

Parameter range

n = 0, 1, 48, 49

Function

Selects bidirectional or unidirectional printing, according to the parameters below:

n = 0 or 48	Bidirectional printing
1 or 49	Unidirectional printing

Default

Bidirectional printing (may depend on DIP-switch setting)

Notes

- Unidirectional printing provides better alignment of vertical lines, while bidirectional printing is faster.
- If unidirectional is selected by DIP switch, you cannot select bidirectional printing with this command.

Printers not featuring this command

None

Model-dependent variations

None

Related topics

Selecting unidirectional print head movement

Format

ASCII	ESC	U	n
Hex	1B	55	n
Decimal	27	85	n

Parameter range

n = 0, 1, 48, 49

Function

Selects bidirectional or unidirectional printing, according to the parameters below:

n = 0 or 48	Bidirectional printing
1 or 49	Unidirectional printing

Default

Bidirectional printing (may depend on DIP-switch setting)

Notes

- Unidirectional printing provides better alignment of vertical lines, while bidirectional printing is faster.
- If unidirectional is selected by DIP switch, you cannot select bidirectional printing with this command.

Printers not featuring this command

None

Model-dependent variations

None

Related topics

Selecting unidirectional print head movement

Format

ASCII	ESC	<
Hex	1B	3C
Decimal	27	60

Function

Moves the print head to the extreme left position so the next line will print left to right

Default

Bidirectional printing (may depend on DIP-switch setting)

Notes

This is a nonrecommended command; use the ESC U command instead.

Printers not featuring this command

None

Model-dependent variations

None

Related topics

ESC U

Format

ASCII	ESC	<
Hex	1B	3C
Decimal	27	60

Function

Moves the print head to the extreme left position so the next line will print left to right

Default

Bidirectional printing (may depend on DIP-switch setting)

Notes

This is a nonrecommended command; use the ESC U command instead.

Printers not featuring this command

None

Model-dependent variations

None

Related topics

ESC U

Format

ASCII	BEL
Hex	07
Decimal	7

Function

Sounds the printer's beeper for 1/10 second

Notes

This is a nonrecommended command.

Printers not featuring this command

None

Model-dependent variations

None

Format

ASCII	BEL
Hex	07
Decimal	7

Function

Sounds the printer's beeper for 1/10 second

Notes

This is a nonrecommended command.

Printers not featuring this command

None

Model-dependent variations

None

Format

ASCII	ESC	8
Hex	1B	38
Decimal	27	56

Function

- The printer continues printing when the end of the paper is reached.
- No beeper sounds when the end of paper is reached, but the printer sets the PE (printer-error) signal to high and the parallel interface error signal to low.

Default

Paper-out detector enabled

Notes

This is a nonrecommended command.

Printers not featuring this command

DFX-5000, DFX-8000, DFX-5000+

Model-dependent variations

None

Related topics

ESC 9

Format

ASCII	ESC	9
Hex	1B	39
Decimal	27	57

Function

- The printer stops printing when the end of the paper is reached
- The beeper sounds when the end of paper is reached, and the printer sets the PE (printer-error) signal to high and the parallel interface error signal to low

Default

Paper-out detector is enabled

Notes

This is a nonrecommended command.

Printers not featuring this command

DFX-5000, DFX-8000, DFX-5000+

Model-dependent variations

None

Related topics

ESC 8

Format

ASCII	ESC	s	n
Hex	1B	73	n
Decimal	27	115	n

Parameter range

n = 0, 1, 48, 49

Function

Controls printing speed as follows:

n = 0 or 48	Prints at normal speed
1 or 49	Prints at low speed

Default

Normal-speed printing

Notes

- This is a nonrecommended command.
- This command has been deleted in ESC/P 2.

Printers not featuring this command

ActionPrinter L-1000, ActionPrinter 3000, ActionPrinter 4000, ActionPrinter 4500, DLQ-2000, LQ-200, LQ-400, LQ-500, LQ-510, LQ-850, LQ-850+, LQ-860, LQ-860+, LQ-950, LQ-1050, LQ-1050+, LQ-1060, LQ-1060+, LQ-2550, All ESC/P2 printers

Model-dependent variations

None

Format

ASCII	ESC	s	n
Hex	1B	73	n
Decimal	27	115	n

Parameter range

n = 0, 1, 48, 49

Function

Controls printing speed as follows:

n = 0 or 48	Prints at normal speed
1 or 49	Prints at low speed

Default

Normal-speed printing

Notes

This is a nonrecommended command.

Printers not featuring this command

DFX-5000, DFX-8000, DFX-5000+

Model-dependent variations

None

Format

ASCII	ESC	(G	n _L	n _H	m
Hex	1B	28	47	n _L	n _H	m
Decimal	27	40	71	n _L	n _H	m

Parameter range

n_L = 1
n_H = 0
m = 1, 49

Function

Selects graphics mode (allowing you to print raster graphics)

Notes

- This command is available only on printers featuring ESC/P 2.
- Exit graphics mode by sending the ESC @ (Initialize printer) command.
- This command clears all user-defined characters and tab settings.
- Text printing is not possible during graphics mode.
- Do not mix text and graphics-mode printing on the same page.
- Only the following commands are available in graphics mode; the printer ignores all other commands:

LF	Line feed
FF	Form feed
CR	Carriage return
ESC EM	Control paper loading/ejecting
ESC @	Initialize printer (exit graphics mode)
ESC .	Print raster graphics
ESC . 2	Enter TIFF compressed mode*
ESC (i	Select MicroWeave print mode*
ESC (c	Set page format
ESC (C	Set page length in defined unit
ESC (V	Set absolute vertical print position
ESC (v	Set relative vertical print position
ESC \	Set relative vertical print position
ESC \$	Set absolute horizontal print position
ESC r	Select printing color
ESC U	Turn unidirectional mode on/off
ESC +	Set n/360-inch line spacing
ESC (U	Set unit

* The ESC . 2 and ESC (i commands are available only with the Stylus COLOR and later inkjet printer models.

Printers not featuring this command

All non-ESC/P 2 printers

Model-dependent variations

None

Related topics

ESC ., ESC . 2, ESC (i, Sending graphics data, Graphics mode, Binary Mode Commands

Format

ASCII	ESC	(i	01	00	n
Hex	1B	28	69	01	00	n
Decimal	27	40	105	01	00	n

Parameter range

n = 0, 1, 48, 49

Function

Turns MicroWeave print mode off and on:

n = 0 or 48	MicroWeave off
1 or 49	MicroWeave on

Notes

- MicroWeave printing takes longer, but improves printout appearance by reducing banding.
- This command is only available during raster graphics printing.
- Sending an ESC @ or ESC (G command turns MicroWeave printing off.
- Always send this command before loading paper

Printers featuring this command

Stylus COLOR

Model-dependent variations

None

Related topics

ESC ., ESC . 2, ESC (G, ESC @, Sending graphics data, Graphics mode

Format

ASCII	ESC	.	c	v	h	m	n _L	n _H	d ₁	d ₂	...	d _k
Hex	1B	2E	c	v	h	m	n _L	n _H	d ₁	d ₂	...	d _k
Decimal	27	46	c	v	h	m	n _L	n _H	d ₁	d ₂	...	d _k

Parameter range

- c = 0
- c = 1
- v = 5, 10, 20
- h = 5, 10, 20
- m = 1, 8, 24
- 0 ≤ n_L ≤ 255
- 0 ≤ n_H ≤ 127
- 0 ≤ d ≤ 255

The following vertical and horizontal printing resolution combinations are available:

v	h	v (dpi)	h (dpi)	m
20	20	180	180	1, 8, or 24
20	20	180	360	1, 8, or 24
10	10	360	360	1, 8, or 24

Stylus COLOR only

5	5	720	720	1 (with speical paper)
---	---	-----	-----	------------------------

Function

- Prints dot graphics in raster format (row by row, left to right)
- Allows compression of graphics data during raster graphics printing; counters can be included with data to specify the number of times to repeat a particular byte of data
- Parameters are used as described below:

- c = 0 Full graphics mode (noncompressed)
- 1 Compressed raster graphics (Run Length Encoding) mode
- v Vertical resolution in dpi—720, 360, 180 (3600/v dpi)
- h Horizontal resolution in dpi—720, 360, 180 (3600/h dpi)
- m Vertical dot count (rows of dot graphics)
- n_L, n_H Horizontal dot count (columns of dot graphics), according to the following formula:

$$n_H = \text{INT} \frac{(\text{horizontal dot count})}{256}$$

$$n_L = \text{MOD} \frac{(\text{horizontal dot count})}{256}$$

k Total number of data bytes, according to the following formula:

$$k = m \times \text{INT} \frac{(n_H \times 256) + n_L + 7}{8}$$

d *During full graphics mode:*
Graphics data

During RLE compressed raster graphics mode (ESC . 1):

The first data byte is treated as a counter. Graphics data bytes then alternate with a data counter byte (run-length data compression), as follows:

$$0 \leq (\text{counter byte}) \leq 127$$

Counter specifies the number of data bytes following according to the formula below.

$$(\text{counter byte}) + 1 = (\text{number of data bytes to follow}) \text{ or}$$

$$(\text{counter byte}) = (\text{number of data bytes to follow}) - 1$$

$$128 \leq (\text{counter byte}) \leq 255$$

Counter specifies the number of times to repeat the next byte of data according to the formula below.

$$256 - (\text{counter byte}) + 1 = (\text{number of times to repeat next byte})$$

$$(\text{counter byte}) = 257 - (\text{number of times to repeat next byte})$$

Notes

- Use only one image density and do not change this setting once in raster graphics mode.
- Parameters in bold are new to this command and apply to the Stylus COLOR and later printer models.
- When MicroWeave is selected, the image height *m* must be set to 1.
- Special coated stock paper available from EPSON is required when printing raster graphics at 720 dpi.
- This command is available only on printers featuring ESC/P 2.
- This command can be used only during graphics mode, entered by sending the ESC (G command.
- The combination of *v* = 10 and *h* = 20 (360 dpi by 180 dpi) is not possible.
- You can specify the horizontal dot count in 1-dot increments. If the dot count is not a multiple of 8, the remaining data in the data byte at the far right of each row is ignored.
- The final print position is the dot after the far right dot on the top row of the graphics printed with this command.
- Repetitive data bytes can be mixed with data blocks in the same command.
- You cannot move the print position in a negative direction (up) while in graphics mode. Also, the printer ignores commands moving the vertical print position in a negative direction if the final position would be above any graphics printed with this command.

- Print data that exceeds the right margin is ignored.
- Do not specify the vertical movement in increments smaller than the current print density.

Printers not featuring this command

All non-ESC/P 2 printers

Model-dependent variations

Vertical and horizontal resolutions of 720 dpi are available only with the Stylus COLOR.

Related topics

ESC (G, Sending graphics data, Raster graphics

Format

ASCII	ESC	.	2	v	h	1	0	0
Hex	1B	2E	2	v	h	1	0	0
Decimal	27	46	2	v	h	1	0	0

Parameter range

v = 5,10, 20	vertical resolutions in dpi—720, 360, 180 (3600/v dpi)
h = 5,10, 20	horizontal resolutions in dpi—720, 360, 180 (3600/h dpi)

The following vertical and horizontal printing resolution combinations are available:

v	h	v (dpi)	h (dpi)
20	20	180	180
20	10	180	360
10	10	360	360

Stylus COLOR only

5	5	720	720 (with special paper)
---	---	-----	--------------------------

Function

- Enters TIFF raster graphics compressed mode
- The following commands are available in TIFF mode (all other codes are ignored):

<XFER>	Transfer raster graphics data
<MOVX>	Set relative horizontal position
<MOVY>	Set relative vertical position
<COLR>	Select printing color
<CR>	Carriage return to left-most print position
<EXIT>	Exit TIFF mode
<MOVXBYTE>	Set <MOVX> unit to 8 dots
<MOVXDOT>	Set <MOVX> unit to 1 dot

- This mode allows compression of graphics data during raster graphics printing.

Notes

- This command can be used only during graphics mode, which is entered by sending the ESC (G command.
- This command pertains only to Stylus COLOR and later printer models.
- Use only one image density and do not change this setting after entering raster graphics mode.
- Do not overwrite image data.
- The horizontal positioning should be a multiple of 8, otherwise the printer's throughput will decline.
- The combination of v = 10 and h = 20 (360 vertical dots by 180 horizontal dots) is not possible.

- Special coated stock paper available from EPSON is required when printing raster graphics at 720 dpi.
- Do not specify the vertical movement in increments smaller than the current print density.

Printers featuring this command

Stylus COLOR

Model-dependent variations

None

Related topics

ESC ., ESC (G, ESC @, Sending graphics data, Graphics mode, Binary Mode Commands

Format

ASCII	ESC	*	m	n _L	n _H	d ₁	...	d _k
Hex	1B	2A	m	n _L	n _H	d ₁	...	d _k
Decimal	27	42	m	n _L	n _H	d ₁	...	d _k

Parameter range

$$0 \leq n_L \leq 255$$

$$0 \leq n_H \leq 31$$

$$m = 0, 1, 2, 3, 4, 6, 32, 33, 38, 39, 40, 71, 72, 73$$

Function

Prints dot-graphics in 8, 24, or 48-dot columns, depending on the following parameters:

- m** Specifies the dot density (see table below)
n_L, n_H Specifies the total number of columns of graphics data that follow

$$(\text{number of dot columns}) = ((n_H \times 256) + n_L)$$

$$n_H = \text{INT} \frac{(\text{number of dot columns})}{256}$$

$$n_L = \text{MOD} \frac{(\text{number of dot columns})}{256}$$

- d₁ ... d_k** Bytes of graphics data; k is determined by multiplying the total number of columns times the number of bytes required for each column (see the table below)

Dot density

Parameter m in ESC * command	Horizontal density (dpi)	Vertical density (dpi)		Adjacent dot printing	Dots per column	Bytes per column
		24 pin	48 pin			
0	60	60	60	Yes	8	1
1	120	60	60	Yes	8	1
2	120	60	60	No	8	1
3	240	60	60	No	8	1
4	80	60	60	Yes	8	1
6	90	60	60	Yes	8	1
32	60	180	180	Yes	24	3
33	120	180	180	Yes	24	3
38	90	180	180	Yes	24	3
39	180	180	180	Yes	24	3
40	360	180	180	No	24	3
71	180	N/A	360	Yes	48	6
72	360	N/A	360	No	48	6
73	360	N/A	360	Yes	48	6

Notes

- Not all values for m are available on all printers; see the Command Table for a list of which values are available on your printer.
- Printing 48-dot columns is available only on 48-dot printers.

Printers not featuring this command

None

Model-dependent variations

ActionPrinter 3000, ActionPrinter 4000, ActionPrinter 4500, LQ-510, LQ-550, LQ-850, LQ-850+, LQ-860, LQ-860+, LQ-950, LQ-1010, LQ-1050, LQ-1050+, LQ-1060, LQ-1060+, LQ-2550, and all ESC/P 2 printers

A vertical print density of 360 dpi can be achieved on 24-pin printers that feature the ESC + command. Advance the paper 1/360 inch (using the ESC + command) and then overprint the previous graphics line.

Related topics

Sending graphics data, Bit-image graphics

Format

ASCII	ESC	*	m	n _L	n _H	d ₁	...	d _k
Hex	1B	2A	m	n _L	n _H	d ₁	...	d _k
Decimal	27	42	m	n _L	n _H	d ₁	...	d _k

Parameter range

- 0 ≤ n_L ≤ 255
- 0 ≤ n_H ≤ 31
- m = 0, 1, 2, 3, 4, 5, 6, 7

Function

Prints dot-graphics in 8-dot columns, depending on the following parameters:

- m Specifies the dot density (see table below)
- n_L, n_H Specify the total number of columns (k) of graphics data following, according to the formula

$$\begin{aligned}
 &(\text{number of dot columns}) = ((n_H \times 256) + n_L) \\
 n_H &= \text{INT} \frac{(\text{number of dot columns})}{256} \\
 n_L &= \text{MOD} \frac{(\text{number of dot columns})}{256}
 \end{aligned}$$

d₁ . . . d_k Bytes of graphics data

Dot density

Parameter m in ESC * command	Horizontal density	Vertical density	Adjacent dot printing	Dots per column	Bytes per column
0	60	72	Yes	8	1
1	120	72	Yes	8	1
2	120	72	No	8	1
3	240	72	No	8	1
4	80	72	Yes	8	1
5	72	72	Yes	8	1
6	90	72	Yes	8	1
7	144	72	Yes	8	1

Notes

- Graphics data that would print beyond the right-margin position is ignored.
- Bit-image graphics can be printed on the same line as text.
- Not all values for m are available on all printers; see the Command Table for a list of which values are available on your printer.

Printers not featuring this command

None

Model-dependent variations

ActionPrinter Apex 80, ActionPrinter T-1000, ActionPrinter 2000, ActionPrinter 2250, LX-100, LX-300, LX-400, LX-800, LX-810, LX-850, LX-1050, LX-1050+

Parameter 7 (144 dot horizontal density) is not available.

Related topics

Sending graphics data, Bit-image graphics

Format

ASCII	ESC	?	n	m
Hex	1B	3F	n	m
Decimal	27	63	n	m

Parameter range

n = 75, 76, 89, 90

m = 0, 1, 2, 3, 4, 6, 32, 33, 38, 39, 40, 71, 72, 73

Function

Assigns the dot density used during the ESC K, ESC L, ESC Y, or ESC Z commands to the density specified by parameter m in the ESC * command

Default

ESC K is assigned density 0

ESC L is assigned density 1

ESC Y is assigned density 2

ESC Z is assigned density 3

Notes

- This is a nonrecommended command; use the ESC * command to print graphics rather than the ESC K, ESC L, ESC Y, or ESC Z commands.
- Bit-image modes that handle data in 48-dot columns can only be printed on 48-dot printers.

Printers not featuring this command

None

Model-dependent variations

See the Command Table for the m values that can be reassigned in each printer model.

Related topics

ESC *

Format

ASCII	ESC	?	n	m
Hex	1B	3F	n	m
Decimal	27	63	n	m

Parameter range

n = 75, 76, 89, 90

m = 0, 1, 2, 3, 4, 5, 6, 7

Function

Assigns the dot density used during the ESC K, ESC L, ESC Y, or ESC Z commands to the density specified by parameter m in the ESC * command

Default

ESC K is assigned density 0

ESC L is assigned density 1

ESC Y is assigned density 2

ESC Z is assigned density 3

Notes

This is a nonrecommended command; use the ESC * command to print graphics rather than the ESC K, ESC L, ESC Y, or ESC Z commands.

Printers not featuring this command

None

Model-dependent variations

See the Command Table for the m values that can be reassigned in each printer model.

Related topics

ESC *

Format

ASCII	ESC	K	n _L	n _H	d ₁	d ₂	...	d _k
Hex	1B	4B	n _L	n _H	d ₁	d ₂	...	d _k
Decimal	27	75	n _L	n _H	d ₁	d ₂	...	d _k

Parameter range

$$0 \leq n_L \leq 255$$

$$0 \leq n_H \leq 31$$

$$0 \leq d \leq 255$$

Function

Prints bit-image graphics in 8-dot columns, at a density of 60 horizontal by 60 vertical dpi, according to the following parameters:

n_L, n_H Specify the total number of columns (k) of graphics data following, according to the formula

$$k = ((n_H \times 256) + n_L)$$

$$n_H = \text{INT} \frac{k}{256}$$

$$n_L = \text{MOD} \frac{k}{256}$$

d₁ . . . d_k Bytes of graphics data

Notes

- This is a nonrecommended command. The ESC * 0 command is identical to this command; use ESC * 0 instead of this command.
- The dot density printed with this command can be redefined with the ESC ? command.

Printers not featuring this command

None

Model-dependent variations

None

Related topics

ESC *

Format

ASCII	ESC	K	n _L	n _H	d ₁	d ₂	...	d _k
Hex	1B	4B	n _L	n _H	d ₁	d ₂	...	d _k
Decimal	27	75	n _L	n _H	d ₁	d ₂	...	d _k

Parameter range

$$0 \leq n_L \leq 255$$

$$0 \leq n_H \leq 31$$

$$0 \leq d \leq 255$$

Function

Prints bit-image graphics in 8-dot columns, at a density of 60 horizontal by 72 vertical dpi, according to the following parameters:

n_L, n_H Specify the total number of columns (k) of graphics data following, according to the formula

$$k = ((n_H \times 256) + n_L)$$

$$n_H = \text{INT} \frac{k}{256}$$

$$n_L = \text{MOD} \frac{k}{256}$$

d₁ . . . d_k Bytes of graphics data

Notes

- This is a nonrecommended command. The ESC * 0 command is identical to this command; use ESC * 0 instead of this command.
- The dot density printed with this command can be redefined with the ESC ? command.

Printers not featuring this command

None

Model-dependent variations

None

Related topics

ESC *

Format

ASCII	ESC	L	n _L	n _H	d ₁	d ₂	...	d _k
Hex	1B	4C	n _L	n _H	d ₁	d ₂	...	d _k
Decimal	27	76	n _L	n _H	d ₁	d ₂	...	d _k

Parameter range

$$0 \leq n_L \leq 255$$

$$0 \leq n_H \leq 31$$

$$0 \leq d \leq 255$$

Function

Prints bit-image graphics in 8-dot columns, at a density of 120 horizontal by 60 vertical dpi, according to the following parameters:

n_L, n_H Specify the total number of columns (k) of graphics data following, according to the formula

$$k = (n_H \times 256) + n_L$$

$$n_H = \text{INT} \frac{k}{256}$$

$$n_L = \text{MOD} \frac{k}{256}$$

d₁ . . . d_k Bytes of graphics data

Notes

- This is a nonrecommended command. The ESC * 1 command is identical to this command; use ESC * 1 instead of this command.
- The dot density printed with this command can be redefined with the ESC ? command.

Printers not featuring this command

None

Model-dependent variations

None

Related topics

ESC *

Format

ASCII	ESC	L	n _L	n _H	d ₁	d ₂	...	d _k
Hex	1B	4C	n _L	n _H	d ₁	d ₂	...	d _k
Decimal	27	76	n _L	n _H	d ₁	d ₂	...	d _k

Parameter range

$$0 \leq n_L \leq 255$$

$$0 \leq n_H \leq 31$$

$$0 \leq d \leq 255$$

Function

Prints bit-image graphics in 8-dot columns, at a density of 120 horizontal by 72 vertical dpi, according to the following parameters:

n_L, n_H Specify the total number of columns (k) of graphics data following, according to the formula

$$k = ((n_H \times 256) + n_L)$$

$$n_H = \text{INT} \frac{k}{256}$$

$$n_L = \text{MOD} \frac{k}{256}$$

d₁ . . . d_k Bytes of graphics data

Notes

- This is a nonrecommended command. The ESC * 1 command is identical to this command; use ESC * 1 instead of this command.
- The dot density printed with this command can be redefined with the ESC ? command.

Printers not featuring this command

None

Model-dependent variations

None

Related topics

ESC *

Format

ASCII	ESC	Y	n _L	n _H	d ₁	d ₂	...	d _k
Hex	1B	59	n _L	n _H	d ₁	d ₂	...	d _k
Decimal	27	89	n _L	n _H	d ₁	d ₂	...	d _k

Parameter range

$$0 \leq n_L \leq 255$$

$$0 \leq n_H \leq 31$$

$$0 \leq d \leq 255$$

Function

Prints bit-image graphics in 8-dot columns, at a density of 120 horizontal by 60 vertical dpi, according to the following parameters:

n_L, n_H Specify the total number of columns (k) of graphics data following, according to the formula

$$k = (n_H \times 256) + n_L$$

$$n_H = \text{INT} \frac{k}{256}$$

$$n_L = \text{MOD} \frac{k}{256}$$

d₁ . . . d_k Bytes of graphics data

Notes

- This is a nonrecommended command. The ESC * 2 command is identical to this command; use ESC * 2 instead of this command.
- The speed is double because consecutive horizontal dots cannot be printed; the printer ignores the second continuous horizontal dot.
- The dot density printed with this command can be redefined with the ESC ? command.

Printers not featuring this command

None

Model-dependent variations

None

Related topics

ESC *

Format

ASCII	ESC	Y	n _L	n _H	d ₁	d ₂	...	d _k
Hex	1B	59	n _L	n _H	d ₁	d ₂	...	d _k
Decimal	27	89	n _L	n _H	d ₁	d ₂	...	d _k

Parameter range

$$0 \leq n_L \leq 255$$

$$0 \leq n_H \leq 31$$

$$0 \leq d \leq 255$$

Function

Prints bit-image graphics in 8-dot columns, at a density of 120 horizontal by 72 vertical dpi, according to the following parameters:

n_L, n_H Specify the total number of columns (k) of graphics data following, according to the formula

$$k = (n_H \times 256) + n_L$$

$$n_H = \text{INT} \frac{k}{256}$$

$$n_L = \text{MOD} \frac{k}{256}$$

d₁ . . . d_k Bytes of graphics data

Notes

- This is a nonrecommended command. The ESC * 2 command is identical to this command; use ESC * 2 instead of this command.
- The speed is double because consecutive horizontal dots cannot be printed; the printer ignores the second continuous horizontal dot.
- The dot density printed with this command can be redefined with the ESC ? command.

Printers not featuring this command

None

Model-dependent variations

None

Related topics

ESC *

Format

ASCII	ESC	Z	n _L	n _H	d ₁	d ₂	...	d _k
Hex	1B	5A	n _L	n _H	d ₁	d ₂	...	d _k
Decimal	27	90	n _L	n _H	d ₁	d ₂	...	d _k

Parameter range

$$0 \leq n_L \leq 255$$

$$0 \leq n_H \leq 31$$

$$0 \leq d \leq 255$$

Function

Prints bit-image graphics in 8-dot columns, at a density of 240 horizontal by 60 vertical dpi, according to the following parameters:

n_L, n_H Specify the total number of columns (k) of graphics data following, according to the formula

$$k = (n_H \times 256) + n_L$$

$$n_H = \text{INT} \frac{k}{256}$$

$$n_L = \text{MOD} \frac{k}{256}$$

d₁ . . . d_k Bytes of graphics data

Notes

- This is a nonrecommended command. The ESC * 3 command is identical to this command; use ESC * 3 instead of this command.
- The speed is double because consecutive horizontal dots cannot be printed; the printer ignores the second continuous horizontal dot.
- The dot density printed with this command can be redefined with the ESC ? command.

Printers not featuring this command

None

Model-dependent variations

None

Related topics

ESC *

Format

ASCII	ESC	Z	n _L	n _H	d ₁	d ₂	...	d _k
Hex	1B	5A	n _L	n _H	d ₁	d ₂	...	d _k
Decimal	27	90	n _L	n _H	d ₁	d ₂	...	d _k

Parameter range

$$0 \leq n_L \leq 255$$

$$0 \leq n_H \leq 31$$

$$0 \leq d \leq 255$$

Function

Prints bit-image graphics in 8-dot columns, at a density of 240 horizontal by 72 vertical dpi, according to the following parameters:

n_L, n_H Specify the total number of columns (k) of graphics data following, according to the formula

$$k = ((n_H \times 256) + n_L)$$

$$n_H = \text{INT} \frac{k}{256}$$

$$n_L = \text{MOD} \frac{k}{256}$$

d₁ . . . d_k Bytes of graphics data

Notes

- This is a nonrecommended command. The ESC * 3 command is identical to this command; use ESC * 3 instead of this command.
- The speed is double because consecutive horizontal dots cannot be printed; the printer ignores the second continuous horizontal dot.
- The dot density printed with this command can be redefined with the ESC ? command.

Printers not featuring this command

None

Model-dependent variations

None

Related topics

ESC *

Format

ASCII	ESC	^	m	n _L	n _H	d ₁	...	d _k
Hex	1B	5E	m	n _L	n _H	d ₁	...	d _k
Decimal	27	94	m	n _L	n _H	d ₁	...	d _k

Parameter range

- 0 ≤ n_L ≤ 255
- 0 ≤ n_H ≤ 31
- m = 0, 1

Function

Prints dot-graphics in 9-dot columns, depending on the following parameters:

- m Specifies the dot density (see table below)
- n_L, n_H Specify the total number of graphics data bytes (two bytes per column)

$$\begin{aligned} \text{(number of dot columns)} &= ((n_H \times 256) + n_L) \\ n_H &= \text{INT} \frac{\text{(number of dot columns)}}{256} \\ n_L &= \text{MOD} \frac{\text{(number of dot columns)}}{256} \end{aligned}$$

d₁ . . . d_k Bytes of graphics data

Dot density

Parameter m	Horizontal density (dpi)	Vertical density (dpi)	Adjacent dot printing	Dots per column	Bytes per column
0	60	72	Yes	9	2
1	120	72	Yes	9	2

Each dot column requires two bytes of data. The first byte represents the top 8 dots in the print head. Bit 0 (the LSB) in the second byte represents the ninth (bottom) dot in the print head; the remaining 7 bits are ignored.

Notes

- This is a nonrecommended command; use the ESC * command instead.
- Graphics data that would print beyond the right-margin position is ignored.
- Bit-image graphics can be printed on the same line as text.

Printers not featuring this command

None

Model-dependent variations

None

Related topics

ESC *

Format

ASCII	ESC	r	n
Hex	1B	72	n
Decimal	27	114	n

Parameter range

$$0 \leq n \leq 6$$

Function

Selects the color of printing, according to the parameters below:

n = 0	Black
1	Magenta
2	Cyan
3	Violet
4	Yellow
5	Red
6	Green

Default

n = 0 (Black)

Notes

- The printer ignores this command if color printing is not available.
- Print yellow first when overlapping colors.
- Only black, magenta, cyan, and yellow are available during graphics mode selected with the ESC (G command).

Printers not featuring this command

ActionPrinter L-1000, ActionPrinter 3000, ActionPrinter 3250, ActionPrinter 4000, ActionPrinter 5000, ActionPrinter 5500, DLQ-3000, LQ-100, LQ-200, LQ-400, LQ-500, LQ-510, LQ-550, LQ-570, LQ-570+, LQ-670, LQ-850, LQ-850+, LQ-870, LQ-950, LQ-1010, LQ-1050, LQ-1050+, LQ-1070, LQ-1070+, LQ-1170, LQ-2070, LQ-2170, SQ-870, SQ-1170, SQ-2550, TLQ-4800, TSQ-4800, Stylus 300, Stylus 800, Stylus 800+, Stylus 1000, Stylus 400

Model-dependent variations

None

Related topics

<COLR>, Selecting print color

Format

ASCII	ESC	r	n
Hex	1B	72	n
Decimal	27	114	n

Parameter range

$0 \leq n \leq 6$

Function

Selects the color of printing, according to the parameters below:

n = 0	Black
1	Magenta
2	Cyan
3	Violet
4	Yellow
5	Red
6	Green

Default

n = 0 (Black)

Notes

- The printer ignores this command if color printing is not available.
- Print yellow first when overlapping colors.

Printers not featuring this command

ActionPrinter Apex 80, ActionPrinter T-750, ActionPrinter T-1000, ActionPrinter 2000, ActionPrinter 2250, ActionPrinter 2500, DFX-5000, DFX-5000+, DFX-8000, FX-850, FX-870, FX-1050, FX-1170, FX-2170, LX-100, LX-400, LX-800, LX-810, LX-850, LX-1050, LX-1050+

Model-dependent variations

None

Related topics

Selecting print color

Format

ASCII	ESC	(B	n _L	n _H	k	m	s	v ₁	v ₂	c	BarCodeData
Hex	1B	28	42	n _L	n _H	k	m	s	v ₁	v ₂	c	BarCodeData
Decimal	27	40	66	n _L	n _H	k	m	s	v ₁	v ₂	c	BarCodeData

Parameter range

- 0 ≤ n_L ≤ 255
- 0 ≤ n_H ≤ 127
- 0 ≤ k ≤ 7
- 2 ≤ m ≤ 5
- 3 ≤ s ≤ 3
- 0 ≤ v₁ ≤ 255
- 0 ≤ v₂ ≤ 127
- 0 ≤ c ≤ 255

Function

- Prints bar codes.
- Parameters are used as described below:

n_L, n_H Total number of data bytes to follow, determined by the following equation:

$$(\text{number of data bytes}) = 6 \text{ bytes} + \text{BarCodeData bytes} = ((n_H \times 256) + n_L)$$

(where 6 bytes are k, m, s, v₁, v₂, and c)

$$n_H = \text{INT} \frac{(\text{number of data bytes})}{256}$$

$$n_L = \text{MOD} \frac{(\text{number of data bytes})}{256}$$

k Bar code type

k (Hex)	Bar code type
00	EAN-13
01	EAN-8
02	Interleaved 2 of 5
03	UPC-A
04	UPC-E
05	Code 39
06	Code 128
07	POSTNET

m Module width

m	24-pin printer (unit 1/180 inch)	9-pin printer (unit 1/120 inch)
02 (default)	2 dots	2 dots
03	3 dots	3 dots
04	4 dots	4 dots
05	5 dots	5 dots

s Space adjustment value

24-pin printer	$-3 \leq s \leq 3$ (unit 1/360 inch)
9-pin printer	$-3 \leq s \leq 3$ (unit 1/240 inch)

v₁, v₂ Bar length

24-pin printer	bar length = $v_1 + v_2 \times 256$ (unit 1/180 inch)
9-pin printer	bar length = $v_1 + v_2 \times 256$ (unit 1/72 inch)

The v₁ and v₂ values are ignored when POSTNET is selected.

Long bar length of POSTNET is always 0.125 inch.

Short bar length of POSTNET is always 0.050 inch.

c Control flag

c	Control flag
bit 0	Check digit 0: A check digit is not added by the printer. 1: A check digit is added by the printer.
bit 1	Human readable character 0: The human readable characters are added by the printer. 1: The human readable characters are not added by the printer.
bit 2	Position of flag character (for EAN-13 and UPC-A only) 0: Center 1: Under
bit 3	(reserved)
bit 4	(reserved)
bit 5	(reserved)
bit 6	(reserved)
bit 7	(reserved)

BarCodeData Corresponds to the bar code symbology.

The data number of each bar code type is constant.

The bar code is not printed if the number of bar code characters are incorrect.

Bar code type	Number of valid characters 1 (HEX)	Number of valid characters 2 (HEX)
EAN-13	0D	0C
EAN-8	08	07
Interleaved 2 of 5	02 to FF	02 to FF
UPC-A	0C	0B
UPC-E	0C or 8	0B or 7
Code 39	01 to FF	01 to FF
Code 128	02 to FF	02 to FF
POSTNET	06 or 0A or 0C	05 or 09 or 0B

Number of valid characters 1: control flag c bit 0 = 0

Number of valid characters 2: control flag c bit 0 = 1

The valid data of each bar code type are following.

If an invalid data is included in the BarCodeData string, the bar code is not printed.

Bar code type	Valid range of BarCodeData
EAN-13	0-9 (30H-39H)
EAN-8	0-9 (30H-39H)
Interleaved 2 of 5	0-9 (30H-39H)
UPC-A	0-9 (30H-39H)
UPC-E	0-9 (30H-39H)
Code 39	0-9 (30H-39H), (41H-5AH) (20H, 24H, 25H, 2BH, 2DH, 2EH, 2FH)
Code 128	Code Set A, Set B, Set C
POSTNET	0-9 (30H-39H)

Notes

- Bar code printing is always performed unidirectionally.
- The bar code is not printed when part of the bar code is out of the right margin.
- Bar code and text data are mixed in a line.
- A kind of Code 128 character sets (A, B or C) is identified by the first data of Code 128. The first data must be a hexadecimal 41 (A), 42 (B) and 43 (C).
- When Code 128 Character Set C and Interleaved 2 of 5 is selected and the number of characters are ODD, "0" is added to the data string.

Printers featuring this command

DLQ-3000 ('96 ~), LQ-670, LQ-2070, LQ-2170

Model-dependent variations

None

Related topics

ESC <, ESC Q, ESC U, Printing Bar Codes

Format

ASCII	ESC	@
Hex	1B	40
Decimal	27	64

Function

Resets the printer to its default settings

Notes

- This command does not affect user-defined characters or control panel (SelectType) settings.
- See each command explanation, for the settings after the ESC @ command is received.
- Use this command to exit graphics mode entered with the ESC (G command.

Printers not featuring this command

None

Model-dependent variations

None

Related topics

Recommended command order

Format

ASCII	ESC	@
Hex	1B	40
Decimal	27	64

Function

Resets the printer to its default settings

Notes

- This command does not affect user-defined characters or control panel (SelectType) settings
- See each command explanation for the settings after the ESC @ command is received.

Printers not featuring this command

None

Model-dependent variations

None

Related topics

Recommended command order

Format

ASCII	CAN
Hex	18
Decimal	24

Function

- Clears all printable characters and bit-image graphics on the current line
- Moves the print position to the left-margin position

Notes

- This is a nonrecommended command.
- This command does not affect (clear) control codes.

Printers not featuring this command

None

Model-dependent variations

None

Format

ASCII	CAN
Hex	18
Decimal	24

Function

- Clears all printable characters and bit-image graphics on the current line
- Moves the print position to the left-margin position

Notes

- This is a nonrecommended command.
- This command does not affect (clear) control codes.

Printers not featuring this command

None

Model-dependent variations

None

Format

ASCII	DEL
Hex	7F
Decimal	127

Function

Deletes the last printable character in the print buffer's current line

Notes

- This is a nonrecommended command.
- This command only deletes printable characters; printer control codes are not affected.
- The printer ignores this command if it follows a command that moves the horizontal print position (ESC \$, ESC \, or HT)

Printers not featuring this command

None

Model-dependent variations

None

Format

ASCII	DEL
Hex	7F
Decimal	127

Function

Deletes the last printable character in the print buffer's current line

Notes

- This is a nonrecommended command.
- This command only deletes printable characters; printer control codes are not affected.
- The printer ignores this command if it follows a command that moves the horizontal print position (ESC \$, ESC \, or HT)

Printers not featuring this command

None

Model-dependent variations

None

Format

ASCII	DC1
Hex	11
Decimal	17

Function

Selects the printer after it has been deselected with the DC3 command

Default

Printer is selected.

Notes

- This is a nonrecommended command. The SLCT IN signal on the interface must be high to use this command. This command is nearly always unnecessary.
- The printer ignores this command if the user has set the printer off line by pressing the on-line button.

Printers not featuring this command

None

Model-dependent variations

None

Format

ASCII	DC1
Hex	11
Decimal	17

Function

Selects the printer after it has been deselected with the DC3 command

Default

Printer is selected.

Notes

- This is a nonrecommended command. The SLCT IN signal on the interface must be high to use this command. This command is nearly always unnecessary.
- The printer ignores this command if the user has set the printer off line by pressing the on-line button.

Printers not featuring this command

None

Model-dependent variations

None

Format

ASCII	DC3
Hex	13
Decimal	19

Function

Deselects the printer

Default

Printer is selected

Notes

- This is a nonrecommended command. The SLCT IN signal on the interface must be high to use this command. This command is nearly always unnecessary.
- The printer remains deselected until it receives a DC1 command, or power is turned off then on again. The printer ignores the ESC @ command (initialize printer) when it is deselected.
- The printer cannot be reselected by pressing the on-line button.

Printers not featuring this command

None

Model-dependent variations

None

Format

ASCII	DC3
Hex	13
Decimal	19

Function

Deselects the printer

Default

Printer is selected

Notes

- This is a nonrecommended command. The SLCT IN signal on the interface must be high to use this command. This command is nearly always unnecessary.
- The printer remains deselected until it receives a DC1 command, or power is turned off then on again. The printer ignores the ESC @ command (initialize printer) when it is deselected.
- The printer cannot be reselected by pressing the on-line button.

Printers not featuring this command

None

Model-dependent variations

None

Format

ASCII	ESC	#
Hex	1B	23
Decimal	27	35

Function

Cancels any controls on the MSB (bit number 7) set by the ESC = or ESC > commands; printer then accepts all MSB data as is

Default

No MSB control

Notes

This is a nonrecommended command; most computer systems no longer require MSB control.

Printers not featuring this command

None

Model-dependent variations

None

Related topics

ESC =, ESC >

Format

ASCII	ESC	#
Hex	1B	23
Decimal	27	35

Function

Cancels any controls on the MSB (bit number 7) set by the ESC = or ESC > commands; printer then accepts all MSB data as is

Default

No MSB control

Notes

This is a nonrecommended command; most computer systems no longer require MSB control.

Printers not featuring this command

ActionPrinter Apex 80, ActionPrinter T-1000, ActionPrinter 2000, ActionPrinter 2250, LX-100, LX-300, LX-400, LX-800, LX-810, LX-850, LX-1050, T-1000

Model-dependent variations

None

Related topics

ESC =, ESC >

Format

ASCII	ESC	=
Hex	1B	3D
Decimal	27	61

Function

Sets the MSB (bit number 7) of all incoming data to 0

Default

No MSB control

Notes

- This is a nonrecommended command; most computer systems no longer require MSB control.
- All data is affected, including graphics data.

Printers not featuring this command

None

Model-dependent variations

None

Related topics

ESC #, ESC >

Format

ASCII	ESC	=
Hex	1B	3D
Decimal	27	61

Function

Sets the MSB (bit number 7) of all incoming data to 0

Default

No MSB control

Notes

- This is a nonrecommended command; most computer systems no longer require MSB control.
- All data is affected, including graphics data.

Printers not featuring this command

ActionPrinter Apex 80, ActionPrinter T-1000, ActionPrinter 2000, ActionPrinter 2250, LX-100, LX-300, LX-400 LX-800, LX-810, LX-850, LX-1050

Model-dependent variations

None

Related topics

ESC #, ESC >

Format

ASCII	ESC	>
Hex	1B	3E
Decimal	27	62

Function

Sets the MSB (bit number 7) of all incoming data to 1

Default

No MSB control

Notes

- This is a nonrecommended command; most computer systems no longer require MSB control.
- All data is affected, including graphics data.

Printers not featuring this command

None

Model-dependent variations

None

Related topics

ESC =, ESC #

Format

ASCII	ESC	>
Hex	1B	3E
Decimal	27	62

Function

Sets the MSB (bit number 7) of all incoming data to 1

Default

No MSB control

Notes

- This is a nonrecommended command; most computer systems no longer require MSB control.
- All data is affected, including graphics data.

Printers not featuring this command

ActionPrinter Apex 80, ActionPrinter T-1000, ActionPrinter 2000, ActionPrinter 2250, LX-100, LX-300, LX-400, LX-800, LX-810, LX-850, LX-1050

Model-dependent variations

None

Related topics

ESC =, ESC #

Format

ASCII	ESC	j	n
Hex	1B	6A	n
Decimal	27	106	n

Parameter range

0 ≤ n ≤ 255

Function

- Reverse feeds paper (moves the print position in the negative direction) n/216 inch
- Prints any data in the buffer

Default

None

Notes

- This is a deleted command.
- Do not reverse-feed paper more than 1/2 inch; the vertical print position may not be accurate otherwise.

Printers featuring this command

Only these printers feature this command: EX-800, EX-1000, FX-80, FX-85, FX-100, FX-185, FX-286, JX-80

Model-dependent variations

None

Related topics

CR, LF, Moving the vertical position

Format

ASCII	ESC	i	n
Hex	1B	69	n
Decimal	27	105	n

Parameter range

n = 0, 1

Function

Switches between character and line printing, as follows:

- n = 1 Prints data on a character by character basis
 If no print data is sent for a short period, moves the vertical print position so that all print is visible
- 0 Prints data on a line by line basis

Default

Printing on a line by line basis

Notes

This is a deleted command.

Printers featuring this command

Only these printers feature this command: EX-800, EX-1000, FX-80, FX-85, FX-100, FX-185, FX-286, JX-80

Model-dependent variations

None

Binary Mode Commands

To accommodate the high-resolution printing capabilities of the Stylus COLOR printer, EPSON has added a raster graphics data compression mode to the existing ESC/P 2 graphics command set: ESC . 2 TIFF compression. This new compression mode also required the introduction of a set of binary commands. For detailed information on programming in compressed raster graphics mode, see the discussion in Recommended Operations.

Binary commands are available only when a compressed raster graphics mode is selected with the ESC . 2 command. In this mode the band height *m* is always set to 1. The binary commands applicable to the TIFF compression mode are listed below.

<XFER>	Transfer raster graphics data
<MOVX>	Set relative horizontal position
<MOVY>	Set relative vertical position
<COLR>	Select printing color
<CR>	Carriage return to left-most print position
<EXIT>	Exit TIFF compressed mode
<MOVXBYTE>	Set <MOVX> unit to 8 dots (one byte)
<MOVXDOT>	Set <MOVX> unit to 1 dot

The command descriptions for the binary mode commands follow.

Format

Class	3				
ASCII	<XFER>	n	d ₁	...	d _n
Binary	001F xxxxB	n	d ₁	...	d _n

Parameter range

#BC = Low nibble value

F = 0 then #BC = number of raster image data, where $0 \leq \#BC \leq 15$

F = 1 then #BC = number of raster image data counter, where #BC = 1, 2
number of raster data = n₁ or n₁ + n₂ × 256

Function

Horizontal print position is moved to the next dot after this command is received

(TIFF format)

- Moves raster data to the band buffer of the selected color.
- Current data does not affect next raster data.

Notes

- This command is available when the ESC . 2 TIFF compressed graphics mode is selected.
- The compressed data format is the same as that for current ESC/P raster compression (ESC . 1).
- This command does not affect the vertical print position.
- Current data does not affect subsequent raster data.
- Do not change the image density in raster graphics mode.
- Do not specify the vertical movement in increments smaller than the current print density.
- Print data that exceeds the right margin is ignored.

Printers featuring this command

Stylus COLOR

Model-dependent variations

None

Related topics

ESC . 2, ESC (i, ESC (G

Format

Class 2
 ASCII <MOVX> n_L n_H
 Binary 010F xxxxB n_L n_H

Parameter range

#BC = Low nibble value

F = 0, 1

0 ≤ n_L ≤ 255

0 ≤ n_H ≤ 127

F	#BC value	Positioning parameter (k)	Command
F = 0	#BC = k	#BC (-8 ~ 7)	<MOVX>
F = 1	#BC = 1	n _L (-128 ~ 127)	<MOVX> n _L
	#BC = 2	n _L + n _H × 256 n _H (-32768 ~ 32767)	<MOVX> n _H

F = 0 then #BC = parameter where -8 ≤ #BC ≤ 7

F = 1 then #BC = number of parameter counter where #BC = 1, 2

Increment unit is 8 or 1 and is selected by the <MOVXDOT> or <MOVXBYTE> command

Function

- This command is available when the ESC . 2 TIFF compressed graphics mode is selected.
- Sets relative horizontal position. The new horizontal position = current position + (parameter) × <MOVX> unit.
- <MOVX> unit is set by the <MOVXDOT> or <MOVXBYTE> command.
- If #BC has a negative value, it is described with two's complement.

Notes

- The unit for this command is determined by the ESC (U set unit command.
- The parameter of the new horizontal position should be a multiple of eight when the dot unit horizontal move is used.
- Settings that exceed the right or left margin will be ignored.

Printers featuring this command

Stylus COLOR

Model-dependent variations

None

Related topics

ESC . 2, ESC (U, <MOVXDOT>, <MOVXBYTE>

Format

Class	2		
ASCII	<MOVY>	n _L	n _H
Binary	011F xxxxB	n _L	n _H

Parameter range

#BC = Low nibble value

 $0 \leq n_L \leq 255$ $0 \leq n_H \leq 127$

F	#BC value	Positioning parameter (k)	Command
F = 0	#BC = k	#BC (0 ~ 15)	<MOVX>
F = 1	#BC = 1	n _L (16 ~ 255)	<MOVX> n _L
	#BC = 2	n _L + n _H × 256 n _H (0 ~ 32767)	<MOVX> n _H

F = 0 then #BC = parameter where $0 \leq \#BC \leq 15$

F = 1 then #BC = number of parameter counter where #BC = 1, 2

Function

- Moves relative vertical position by dot. The new vertical position = current position + (parameter).
- Moves the horizontal print position to 0 (left-most print position).
- Positive value only is allowed. The print position cannot be moved in a negative direction (up).

Notes

- This command is available when the ESC . 2 TIFF compressed graphics mode is selected.
- The unit for this command is determined by the ESC (U set unit command .
- After the vertical print position is moved, all seed row(s) are copied to the band buffer.
- Settings beyond 22 inches are ignored.

Printers featuring this command

Stylus COLOR

Model-dependent variations

None

Related topics

ESC . 2, ESC (i, ESC (U, ESC (G

Format

Class 2
ASCII <COLR>
Binary 1000 xxxxB

Parameter range

1000 0000B	Black
1000 0001B	Magenta
1000 0010B	Cyan
1000 0100B	Yellow

Function

Moves the horizontal print position to 0 (left-most print position).

(TIFF format)

Selects the band buffer color.

Notes

- This command is available when the ESC . 2 TIFF compressed graphics mode is selected.
- Parameters other than those listed above are ignored.
- Combinations of colors are not available and will be ignored.

Printers featuring this command

Stylus COLOR

Model-dependent variations

None

Related topics

ESC . 2, ESC r, ESC (G

Format

Class 1
ASCII <CR>
Binary 1110 0010B

Function

Moves the horizontal print position to 0 (left-most print position).

Printers featuring this command

Stylus COLOR

Model-dependent variations

None

Related topics

ESC . 2, ESC (G

Format

Class 1
ASCII <EXIT>
Binary 1110 0011B

Function

- Exits TIFF compressed raster graphics mode.
- Starts printing of stored data.
- Moves the horizontal print position to 0 (left-most print position).

Notes

This command is available when the ESC . 2 TIFF compressed mode is selected.

Printers featuring this command

Stylus COLOR

Model-dependent variations

None

Related topics

ESC . 2, ESC (i, ESC (G

Format

Class 1
ASCII <MOVXBYTE>
Binary 0010 0100B

Function

- Sets the increment of <MOVX> unit to 8.
- Starts printing of stored data.
- Moves the horizontal print position to 0 (left-most print position).
- Does not move the vertical print position.

Notes

- The unit for this command is determined by the ESC (U set unit command.
- This command is available when ESC . 2 TIFF compressed mode is selected.
- Execute command ESC (G before sending this command.
- Execute this command immediately after entering raster graphics mode by sending the ESC . 2 command.

Printers featuring this command

Stylus COLOR

Model-dependent variations

None

Related topics

ESC . 2, ESC (i, ESC (G

Format

Class 1
ASCII <MOVXDOT>
Binary 0010 0101B

Function

- Sets the increment of <MOVX> unit to 1.
- Starts printing of stored data.
- Moves the horizontal print position to 0 (left-most print position).
- Does not move the vertical print position.

Notes

- The unit for this command is determined by the ESC (U set unit command.
- This command is available when ESC . 2 TIFF compressed mode is selected.
- Execute command ESC (G before sending this command.
- Execute this command immediately after entering raster graphics mode by sending the ESC . 2 command.

Printers featuring this command

Stylus COLOR

Model-dependent variations

None

Related topics

ESC . 2, ESC (i, ESC (G

Recommended Operations

Recommended Command Order	R-4
Set the Printing Area	R-5
The printable area	R-6
Setting left and right margins.....	R-9
Setting page length.....	R-10
Setting top and bottom margins.....	R-13
Setting bottom margin.....	R-13
Select Characters	R-15
Assign character tables.....	R-15
Defining user-defined characters	R-17
Planning user-defined characters.....	R-19
Setting user-defined character traits	R-22
Copying ROM characters to RAM memory.....	R-24
Storing user-defined character data in printer memory.....	R-25
Switching to RAM character printing.....	R-36
Selecting an international character set	R-41
Select a Font	R-42
Print quality (draft, LQ, or NLQ)	R-43
Standard and scalable fonts (multipoint mode).....	R-43
Selecting the character table	R-44
Selecting the point size	R-45
Selecting the typeface	R-47
Selecting the pitch	R-48
Selecting the style.....	R-50
Selecting the weight.....	R-51
Enhancements	R-51
Double-strike	R-51
Shadow/outline	R-52
Score	R-53
Super/subscript	R-54
Select Supporting Features	R-55
Selecting unidirectional print head movement	R-55
Selecting print color.....	R-55
Select the Print Position	R-56
Moving the horizontal position	R-57
Moving the vertical position	R-60
Send Print Data.....	R-64

Sending Graphics Data.....	R-65
Bit-image graphics	R-66
Mixing text and bit-image graphics with ESC/P 2 printers	R-71
Graphics mode	R-73
Standard raster graphics	R-74
Extended raster graphics (ESC . 2)	R-83
Printing Bar Codes.....	R-84
Extended ESC/P 2 Programming Guide.....	R-99
MicroWeave technology.....	R-99
Monochrome printing support	R-100
Color bit-image graphics support.....	R-100
ESC/P 2 color multipoint font support	R-100
ESC/P 2 MicroWeave color raster graphics and RLE compressed raster graphics.....	R-101
ESC/P 2 MicroWeave color extended raster graphics—TIFF.....	R-101
Programming examples	R-104
Example 1: ESC/P 2 color multipoint font driver.....	R-104
Example 2: MicroWeave ESC/P 2 standard color raster graphics and RLE compressed raster graphics driver.....	R-105
Example 3: MicroWeave ESC/P 2 extended color raster graphics and TIFF compressed raster graphics driver.....	R-107

This section describes the recommended method and order of performing operations on an EPSON dot matrix printer. An outline of recommended operation order is provided first, followed by detailed explanations of each operation.

Basic recommendations are provided for printers featuring ESC/P 2. You should follow these recommendations if you are writing programs for ESC/P 2 printers.

In addition, this section provides information on newly added ESC/P 2 commands, known as extended ESC/P 2, as well as programming examples for EPSON's high-resolution (up to 720 by 720 dpi) color printer models.

Where necessary, additional explanations are included for 24/48-pin printers at previous ESC/P levels, as well as for 9-pin printers. Although ESC/P 2 printers can operate using software written for earlier printers (if deleted and nonrecommended commands are avoided), you should use the ESC/P 2 level explanations to take full advantage of advanced ESC/P 2 features.

Recommended Command Order

Because some command results change based on the settings made with other commands, you should send commands and data in the order described in this section.

Once you set the printing area and page length, send data line by line from top to bottom of each page. The printer can handle data most efficiently when received in this order (although commands can move the vertical print position both up and down on a page). The exception to this rule is when printing bit-image graphics and characters on the same line, as described in “Mixing text and bit-image graphics.”

The following order is applicable to all ESC/P levels.

1. Send an ESC @ command to initialize the printer.
2. Set the unit of line spacing to the minimum vertical increment necessary.
3. Set the printing area.
4. Assign character tables to each of the four active tables as necessary (ESC/P 2 printers only).
5. Define any user-defined characters.
6. Select the font.
7. Set supporting features.
8. Set the print position.
9. Send one line's print data.
10. End the line of data with a CR and LF command.
11. Repeat steps 6 to 10 as necessary for each following line on the page.
12. End the page with a FF command.
13. Repeat steps 6 to 12 as necessary for each following page (always send a FF command after the final page also).
14. End printing by sending the ESC @ command.

See the following sections in this chapter for additional information on the above steps.

The printable area

ESC/P 2

ESC/P

9-Pin ESC/P

The printable area for continuous and single-sheet paper is shown below.

Single sheets (also envelopes and single-type multipart forms)

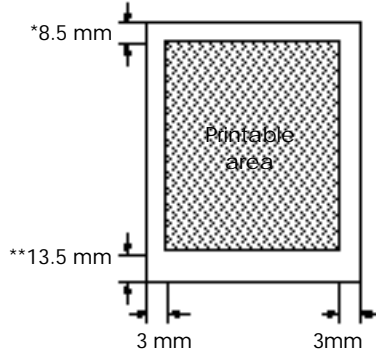

*, ** The nonprintable area varies on some printer models. (See Feature Summary for details.)

Continuous paper

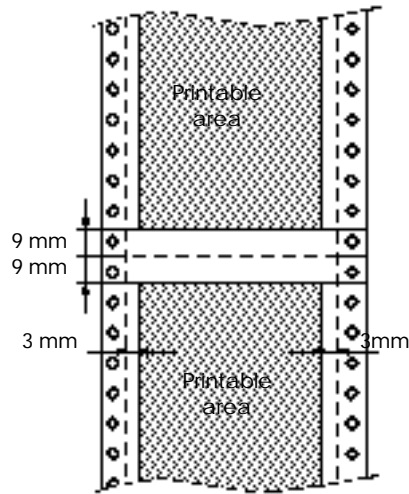

Note:

- Make sure your program keeps printing within this area; otherwise, print quality cannot be assured.
- Make sure the margins stay within the printable area. The area within these margins is called the printing area.

The following diagram shows the printing area for single-sheet and continuous paper.

ESC/P 2

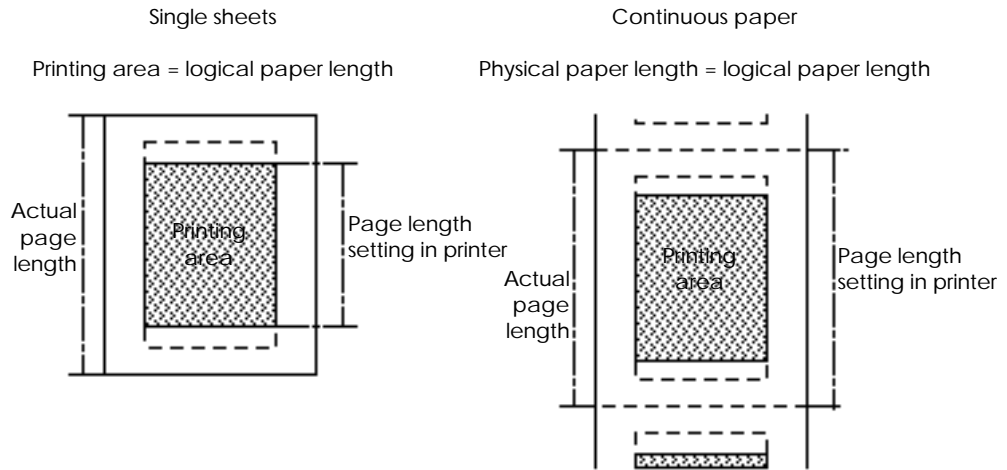

ESC/P 9-Pin ESC/P

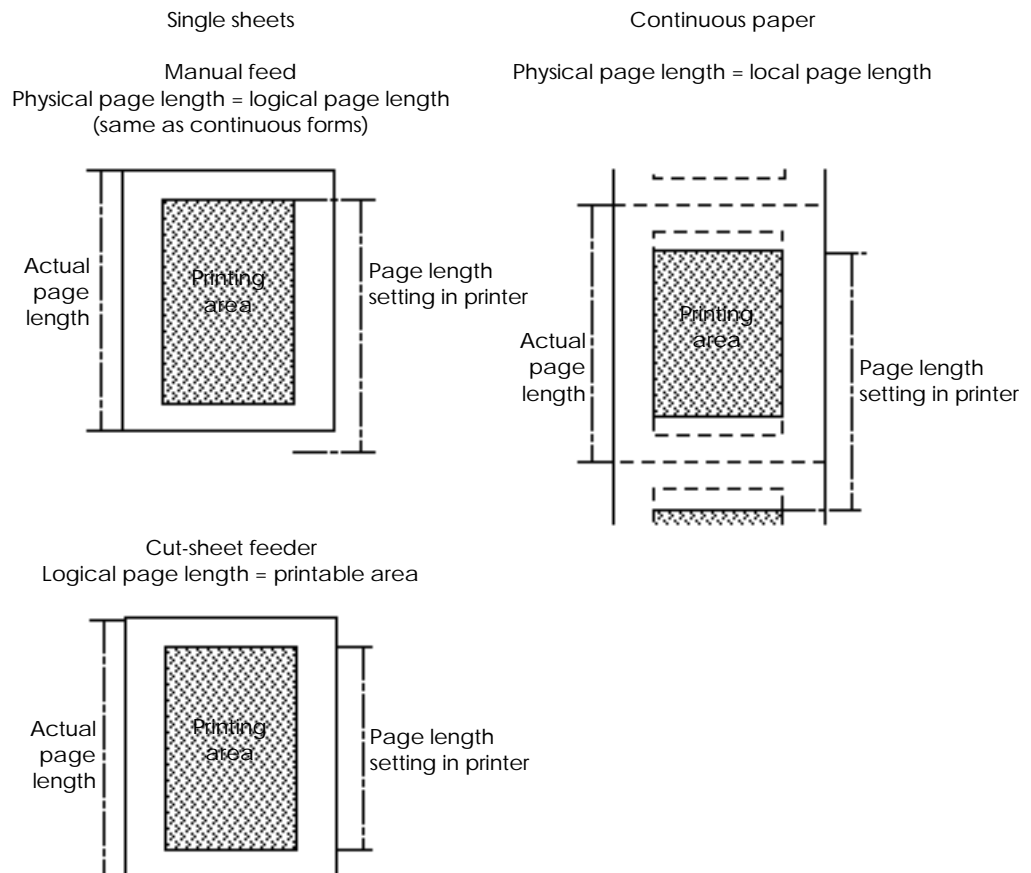

The printing area in ESC/P 2 differs for text and graphics printing.

If the point size is larger than 10.5 points, and the print position is near the top or bottom-margin position, part of the character may print outside the printing area (above the top-margin or below the bottom-margin). The printer prints the full character, even though it falls outside the printing area, with the following exception:

If part of the character falls outside the printable area on single-sheet paper (closer than 8.5 mm to the top edge or closer than 13.5 mm to the bottom edge), printing of that part is not assured.

When setting the vertical print position, you must place enough room at the top and bottom of a page for a full character to print.

The following diagram illustrates the differences between graphics and character printing areas near the top and bottom-margin positions.

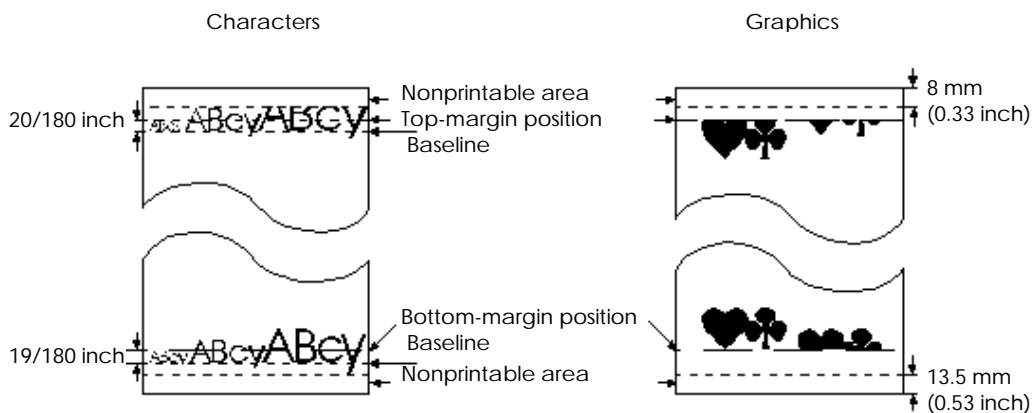

Note:

- You can print characters outside the top and bottom-margin positions as long as the vertical print position is within the printing area. However, character printing within the nonprintable area is not assured; parts of characters may be cut off.
- You cannot print any part of graphics outside the top and bottom-margin positions.

Setting left and right margins

ESC/P 2

ESC/P

9-Pin ESC/P

Use the ESC I command to set the left margin and the ESC Q command to set the right. The format of these commands is as follows:

ESC I m
ESC Q m

The m parameter equals the number of characters from the left-most mechanically printable position, in the current character pitch.

The following commands affect the character pitch (see individual commands in the Command Summary for details):

ESC P	Selects 1/10-inch character width (10 cpi)
ESC M	Selects 1/12-inch character width (12 cpi)
ESC g	Selects 1/15-inch character width (15 cpi)
ESC W 1	Doubles the current character width
ESC p 1	Selects proportional spacing. When setting the margins, the character width is considered to be 1/10 inch
ESC SP n	Adds extra space between each character (n/180 inch for LQ characters and n/120 inch for draft characters on 24/48-pin printers; n/120 inch on 9-pin printers). The resulting character width is:

(current character width) = (previous character width) + (extra space)

SI	Selects condensed printing, resulting in the following character widths: 1/17 inch if 10-cpi is currently selected 1/20 inch if 12-cpi is currently selected
ESC c	Sets the character pitch to between 1/360 and 3 inches (available only on ESC/P 2 printers)
ESC X	Sets pitch and point of scalable fonts (available only on ESC/P 2 printers).

Note:

- Once the margins are set, changing the character width does not affect the margins.

- The margins must be set at the beginning of the line (before any printable data is sent); otherwise, the printer ignores any data preceding these commands.
- Always set pitch before setting left and right margins. Do not assume what the pitch setting will be.

The diagram below shows the margins set by sending the following commands when 8 1/2-inch wide paper is used and the left edge of the paper is at the left-most mechanically printable position.

ESC @	Resets printer settings
ESC P	Selects 10-cpi printing (character width of 1/10 inch)
ESC l 10	Sets a 1-inch left margin
ESC Q 75	Sets a 1-inch right margin

Margin diagram

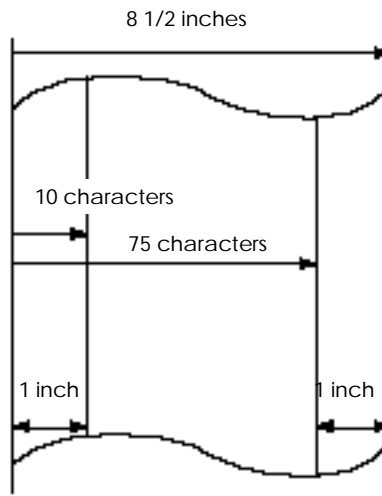

Setting page length

Because the method of page handling is different, the method for setting the page length differs for ESC/P 2 and previous ESC/P versions. This section explains both methods.

ESC/P 2

The ESC/P 2 method of setting the page length allows you to use the same program for both single-sheet and continuous paper.

The page length setting is effective only when you are using continuous paper. However, since the printer ignores the setting during single-sheet printing, the printer is always ready to print on either type of paper.

For single sheets, the printer calculates the page length as the distance between the top and bottom margins.

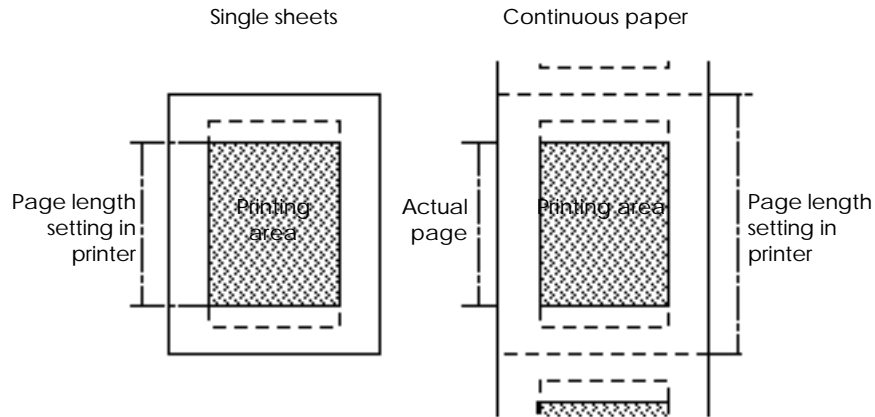

Also, to simplify movement of the horizontal and vertical print position, ESC/P 2 provides the ESC (U command for setting the unit of movement and measurement. The page length is set with the ESC (C command, based on this unit.

Always set the unit before setting the page length. The unit can be set as small as 1/360 inch; set the unit to the minimum size necessary for vertical and horizontal movement within the current print job.

Note:

- Always set the page length before paper is loaded or when the print position is at the top-of-form position. Otherwise, the current print position becomes the top-of-form position, results in undesirable contradictions between the actual and logical page settings.
- Setting the page length cancels any previously set top or bottom margins.
- The maximum page length is 22 inches.
- Changing the unit after the page length has been set does not affect the page length.

The following commands set the page length to 11 inches, based on a unit of 1/360 inch.

ESC (U 1 0 10 Sets a unit of 1/360 inch

ESC (C 2 0 120 15 Selects a page length of 11 inches (3,960 units)

For non-ESC/p 2 printers, set the page length with the following commands:

ESC C	Sets the page length in lines, according to the currentline spacing
ESC C NUL	Sets the page length in 1-inch increments

To set the page length in lines, you must first set the line spacing. The maximum number of lines you can set with the ESC C command is 127.

Use the following commands to set the line spacing:

ESC 2	Selects 1/6-inch line spacing
ESC 0	Selects 1/8-inch line spacing
ESC + n	Selects n/360-inch line spacing (24/48-pin printers only)
ESC 3 n	Selects n/180-inch line spacing (24/48-pin printers)Selects n/216-inch line spacing (9-pin printers)

Note:

- Always set the page length before paper is loaded or when the print position is at the top-of-form position. Otherwise, the current print position becomes the top-of-form position, which results in undesirable contradictions between the actual and logical page settings.
- Setting the page length cancels any previously set bottom margin.
- The maximum page length is 22 inches.
- Changing the line spacing after the page length has been set does not affect the page length.
- Always set the line spacing before setting the page length with the ESC C command. Do not assume what the line spacing will be.

The following commands select 1/6-inch line spacing and a page length of 11 inches (66 lines).

ESC 2	Selects 1/6-inch line spacing
ESC C 66	Sets a page length of 11 inches (66 lines)

The following command also selects a page length of 11 inches.

ESC C NUL 11	Sets a page length of 11 inches
--------------	---------------------------------

Setting top and bottom margins

ESC/P 2

ESC/P 2 provides the ESC (c command for setting both top and bottom margins. This allows the printing area settings to match the actual paper.

The top and bottom margin settings are based on the unit defined with the ESC (U command. If using continuous paper, you should have already defined this unit when you set the page length with the ESC (c command. If not, see the description of the ESC (U command in the Command Summary and “Setting the page length” in this section.

Note:

- Measure top and bottom margins from the top edge of the page.
- The distance from the top edge of the page to the bottom-margin position must be less than the page length; otherwise, the end of the page length becomes the bottom-margin position.
- Setting the top and bottom margins cancels previous top or bottom-margin settings.
- Changing the defined unit does not affect previously set top and bottom-margin settings.
- Always set the top and bottom margins before paper is loaded or when the print position is at the top-of-form position. Otherwise, the current print position becomes the top-of-form position (this results in undesirable contradictions between the actual and logical page settings).

The following command sets a top and bottom margin of 1 inch when the unit is defined as 1/360 inch and 8 1/2 by 11-inch paper is used.

ESC (c 4 0 104 1 16 14 Sets a top margin of 1 inch (360 units) and a bottom margin 10 inches (3,600 units) below the paper's top edge.

Setting bottom margin

ESC/P

9-Pin ESC/P

When using continuous paper on non-ESC/P 2 printers, set the bottom margin with the ESC N command. The printer then automatically moves the print position to the top-of-form position of the next page when it receives a FF command, or when the print position moves below the bottom-margin position.

The ESC N command sets the bottom margin in lines above the top-of-form position of the following page; you must first set the line spacing.

Use one of the following commands to set the line spacing:

ESC 2	Selects 1/6-inch line spacing
ESC 0	Selects 1/8-inch line spacing
ESC + n	Selects n/360-inch line spacing (24/48-pin printers only)
ESC 3 n	Selects n/180-inch line spacing (24/48-pin printers) Selects n/216-inch line spacing (9-pin printers)

Note:

- Sending the ESC N command cancels any previous top or bottom margin setting.
- The bottom margin set with the ESC N command is ignored when printing on single sheets.
- Avoid using this command with ESC/P 2 printers. By using ESC/P 2's ESC (c command instead, the bottom margin is effective for both single-sheet and continuous paper.
- The distance from the top edge of the page to the bottom-margin position must be less than the page length.
- Use the ESC O command to cancel the bottom margin.
- Always set the line spacing before setting the bottom margin with the ESC N command. Do not assume what the line spacing setting will be.

The following commands set a bottom margin of 1 inch when 8 1/2 by 11-inch paper is used (assuming the top-of-form position is at the perforation between pages).

ESC 2	Selects 1/6-inch line spacing
ESC N 6	Sets a bottom margin 1 inch (6 lines) above the next page's top-of-form position.

Select Characters

ESC/P 2

ESC/P

9-Pin ESC/P

Character size and variation have been greatly increased in ESC/P 2. In addition to the basic 10.5-point characters and enhancements available in previous ESC/P versions, scalable font capability allows for the selection of fonts based on point size and five other font attributes. Point size can be selected from 8 to 32 points, in two-point increments.

Also, an increased number of built-in character tables allows access to characters and symbols not previously available.

The following sections explain how to select characters on all EPSON printers. Differences between ESC/P 2 and previous ESC/P versions are explained when necessary.

To select characters, follow the command order outlined below:

1. Use the ESC (t command to assign character tables you plan to use to one of the four active tables selectable with the ESC t command (ESC/P 2 printers only).
2. Define any user-defined (download) characters you plan to use.
3. Select the international character set you plan to use.

By making all the above settings, you have defined the initial characters. See the following sections for details on making each of these settings.

Assign character tables

ESC/P 2

On ESC/P 2 printers, a greater variety of characters is available because of an increased number of built-in character tables.

Previous versions of ESC/P allowed selection of an italics and graphics character table with the ESC t command. ESC/P 2 has expanded on this by allowing access to four active character tables with the ESC t command. Also, you can assign any of the numerous built-in (registered) character tables to these four active tables.

The ESC/P 2 command for assigning these tables is ESC (t. The diagram below illustrates this process.

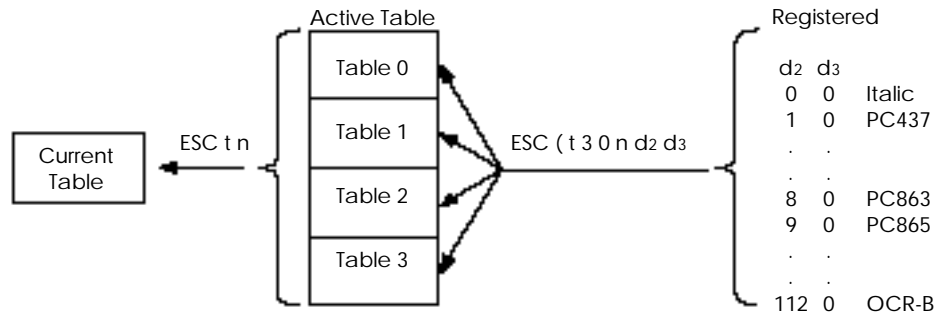

Note:

- You always assign the tables at the beginning of a print job; do not assume what the settings are.
- You can reassign any of the tables at any time, without affecting other table assignments.
- Do not assign a registered table to Table 2 if you plan to use it for user-defined characters. Once you assign a registered table to Table 2, you must reset the printer (with the ESC @ command) before you can use it for user-defined characters.

The following commands assign character tables to active tables 0 to 3.

- | | |
|-------------------|--|
| ESC (t 3 0 0 0 0 | Assigns the italic table to active Table 0. |
| ESC (t 3 0 1 1 0 | Assigns the PC437 (US) table to active Table 1. |
| ESC (t 3 0 2 8 0 | Assigns the PC865 (Canada-French) Table to active Table 2. |
| ESC (t 3 0 3 3 0 | Assigns the PC850 (Multilingual) table to active Table 3. |

Defining user-defined characters

ESC/P 2

ESC/P

9-Pin ESC/P

With the user-defined character function you can design your own characters and save them in the printer's memory for repeated use in a print job.

The printer has two types of character memory: ROM and RAM. The printer stores its built-in character sets in ROM memory; you cannot modify ROM memory. You can modify RAM memory, however, in two ways: you can copy characters from ROM memory and you can save user-defined characters.

The general method of defining characters (sometimes called downloading) is basically the same with all EPSON dot-matrix printers. However, the method of accessing user-defined characters depends on the ESC/P version. This section explains the basic process while describing the differences when necessary.

Note:

You can only print user-defined characters as 10.5-point characters (or 21-point characters when double-height printing is selected). Even if you select a different point size with the ESC X command, characters in RAM can only be printed as 10.5 or 21-point characters.

The steps below should be followed to create user-defined characters.

- 1 Plan the data for your desired characters. The amount of data required depends on the following factors:
 - The number of dots in the print head (9 or 24/48)
 - The space you specify on the left and right of each character
 - Character spacing (10 cpi, 12 cpi, 15 cpi, or proportional)
 - The size of your characters (normal or super/subscript)
 - The print quality of your characters (draft, LQ, or NLQ mode)
- 2 Cancel italics with the ESC 5 command and set the following traits of the characters you plan to define:
 - Print quality
 - Size (either normal or super/subscript)—24/48-pin printers only
 - Proportional or fixed character spacing—24/48-pin printers only

- 3 The printer stores user-defined characters in RAM memory; you must tell the printer to find characters in RAM memory if you want to print user-defined characters. If you plan to use many of the standard characters along with your user-defined characters, use the ESC : command to copy the currently selected character table to the printer's RAM memory. This allows you to print user-defined characters without having to switch from ROM to RAM characters and back again each time.
- 4 Define and send the data to the printer's RAM memory using the ESC & command.
- 5 Switch to RAM characters. The printer then uses the user-defined characters when printing text.

Note:

- On 24/48-pin printers, you can use the ESC t 2 command to copy character data (including user-defined characters) from codes 0 to 127 to codes 128 to 255. This is desirable if you wish to print codes between 0 and 127 as usual while having access to user-defined characters.
- If you plan to use the ESC t 2 command to access user-defined characters on an ESC/P 2 printer, make sure you do not assign a registered character table to active Table 2 with the ESC (t command. Once you have assigned a registered table to Table 2, you cannot use it for user-defined characters (until you reset the printer with the ESC @ command).

Planning user-defined characters

ESC/P 2

ESC/P

9-Pin ESC/P

User-defined characters are defined based on a combination of several traits. This combination of traits determines the number of dots that can be defined (and the amount of data that must be sent) for each character.

These traits, and the maximum recommended size for each combination of traits is shown in the table below. Exceeding the width for the following fixed pitches may not allow for sufficient spacing between characters.

24/48-pin printers (*height · width*)

Traits		Recommended size
Draft	fixed-pitch	24 × 12 (10 cpi)
		24 × 10 (12 cpi)
		24 × 8 (15 cpi)
LQ	fixed-pitch	24 × 36 (10 cpi)
		24 × 30 (12 cpi)
		24 × 24 (15 cpi)
	proportional	24 × 37
	super/subscript	16 × 36 (10 cpi)
		16 × 30 (12 cpi)
		16 × 24 (15 cpi)
super/subscript, proportional	16 × 37	

9-pin printers (*height · width*)

Traits	Recommended size
Draft	8 × 11
NLQ	18 × 12

Note:

For 9-pin printers, NLQ user-defined characters are available only on LX-series printers.

The diagrams below show the planning grids for LQ, NLQ, and draft mode characters.

24/48-pin

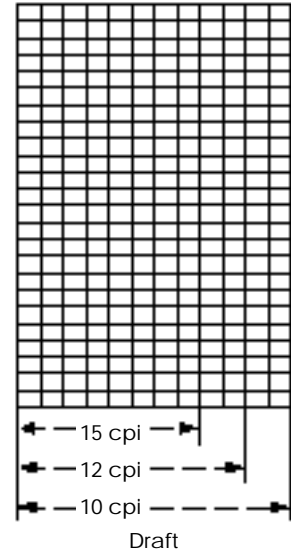
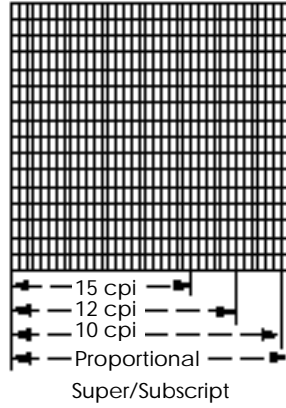
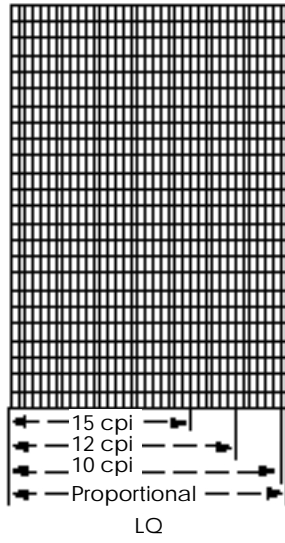

9-pin

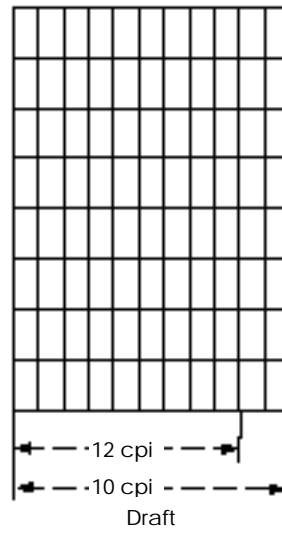
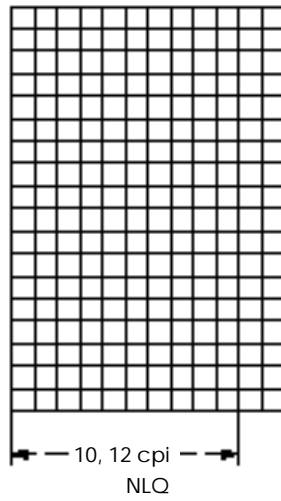

Follow the steps below to plan a user-defined character.

1. First determine the type of characters you wish to define (for example, 24-pin, LQ-mode, 12-cpi characters).
2. Consult the chart above for the maximum recommended dot-matrix size for your selected characters (the maximum for the example in step 1 is 24 dots high \times 30 dots wide).
3. On the appropriate grid for your chosen character attributes, fill in the dots you wish to print to form your character. Keep the following restrictions in mind:
 - You cannot print consecutive horizontal dots on 24-pin printers, or in draft-mode on 9-pin printers. The printer ignores the second of any consecutive horizontal dots. For example, the printer ignores the dots circled below.

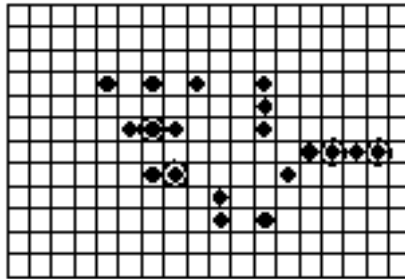

- If you are defining proportional, LQ characters on 24-pin printers, you need to define the space to the left and the right when you send the characters to the printer.
- In the built-in character sets the character baseline is as follows:

24-pin printers	Pin number 20
9-pin printers (draft)	Pin number 7
(NLQ)	Dot number 14 in the 18-dot column

Setting user-defined character traits

Before you can define and save your user-defined characters, you must change the printer settings to match your planned characters. The following combinations of character traits are possible.

24 /48-pin printers

Print quality	Proportional	Fixed pitch
Draft		✓
LQ Normal size	✓	✓
Super/Subscript	✓	✓

9-Pin printers

Print quality	
Draft	✓
NLQ	✓

Note:

You should not store characters in RAM memory when the printer is set to italic printing (with the ESC 4 command). Always send the ESC 5 command to cancel italic printing before you define user-defined characters or copy characters to RAM memory.

Follow the steps below when setting the traits of your planned user-defined and other RAM characters. (Only steps 1 and 2 are necessary for 9-pin printers.)

1. Select the print quality: LQ, NLQ, or draft.
2. Cancel italic printing.
3. Select or cancel proportional spacing.
4. Select or cancel super/subscript characters.

The following commands are used to select the traits for your planned characters.

ESC x 1	Selects LQ-mode or NLQ-mode
ESC x 0	Selects draft
ESC S 0	Selects superscript
ESC S 1	Selects subscript
ESC T	Cancel super/subscript
ESC 5	Cancel italic printing
ESC p 1	Selects proportional spacing
ESC p 0	Cancel proportional spacing

Note:

- Always set or cancel all attributes; don't assume what the current settings are.
- Once you have set the desired attributes, copy the ROM characters to RAM (if necessary) and define all user-defined characters before changing the attributes again. If you change the attributes and then define additional user-defined characters, the printer clears all characters previously in RAM memory.

Copying ROM characters to RAM memory

ESC/P 2

ESC/P

9-Pin ESC/P

You must tell the printer where to find characters: either in the ROM memory (for built-in characters) or in the RAM memory (for user-defined characters). Each time you want to print a user-defined character, you must switch to RAM memory.

You may plan on using many of the standard characters along with your user-defined characters. If so, you can avoid having to switch between ROM and RAM memory each time by copying the characters from the printer's ROM memory to its RAM memory. The ESC : command performs this function.

When you send the ESC : command, the printer copies all the characters from locations 0 to 127 in the currently selected typeface to the same locations in RAM memory. You can then store your user-defined characters and still print all the other characters (except those you redefine) without having to switch back and forth between RAM and ROM memory each time.

Keep the following in mind when copying ROM characters to RAM memory.

- On some printers, you can specify which typeface to copy to RAM memory; see ESC : in the Command Summary and Command Table sections.
- You can only define 10.5-point characters. Even if you select a different point size with the ESC X command, characters in RAM can only be printed as 10.5-point characters (or as 21-point characters if double-height is selected).
- Sending the ESC : command erases any characters that are currently stored in RAM. Always copy ROM characters to RAM before you define user-defined characters. (You cannot copy ROM characters to RAM during multipoint mode.)
- The RAM memory can only store characters of one type at the same time. If you define subscript user-defined characters when normal height characters are stored in RAM memory, for example, the printer erases all previously stored characters. Always set the desired character traits before copying characters (both ROM and user-defined characters).
- Characters copied from ROM to RAM with the ESC : command must have the same traits as the user-defined characters you plan to define. If you define user-defined characters with different traits, the printer erases all previous characters in RAM memory.
- Defining user-defined characters clears any characters previously at that character code location.
- To print characters in RAM, you must first copy characters with the ESC : command or define characters with the ESC & command. The printer ignores commands that would print characters that have not been defined; nothing will be printed.

Storing user-defined character data in printer memory

ESC/P 2

ESC/P

9-Pin ESC/P

Once you have set the necessary traits for your characters (and copied the ROM characters to RAM memory, if desired), you can define and store your user-defined characters.

The following sections cover 9 and 24/48-pin printers. Since the command format is different for 9-pin printers, the explanation in “Sending user-defined characters to the printer” is divided into a 24/48-pin section and a 9-pin section.

Follow the steps below to define user-defined characters.

1. Prepare the data for each character you wish to define (including space to the left and right of each character).
2. Decide where to store your user-defined characters in RAM memory.
3. Use the ESC & command to define the characters in RAM memory.

Preparing data

1. First divide the grid of your planned character into columns. The height and number of columns depend on the traits of the characters you are defining.

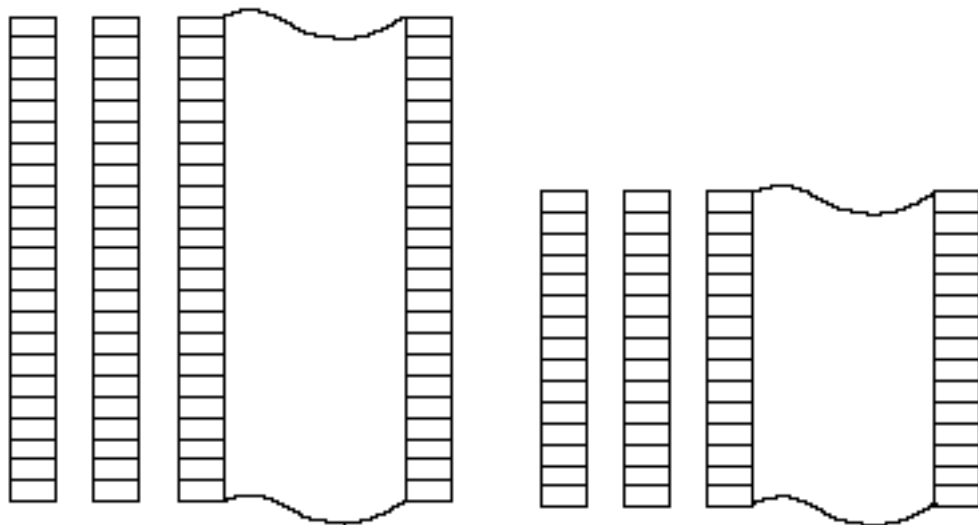

24-pin normal height

24-pin super/subscript

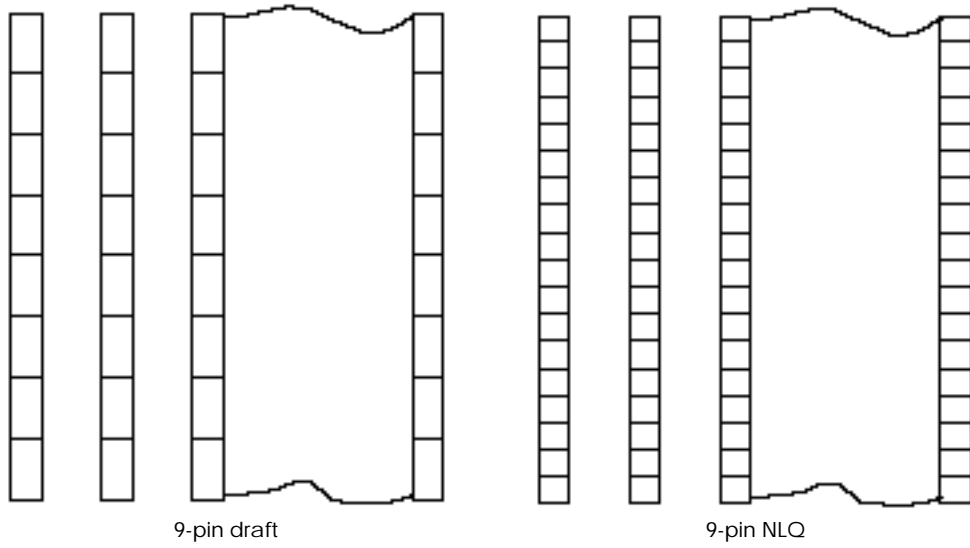

2. Divide each column into the following groups, depending on character and printer traits.

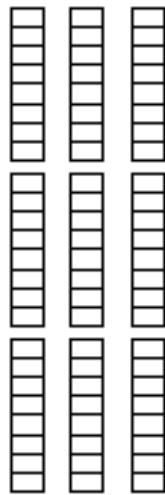

24-pin normal height
3 groups of 8 dots

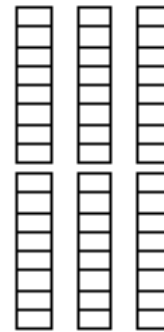

24-pin super/subscript
2 groups of 8 dots

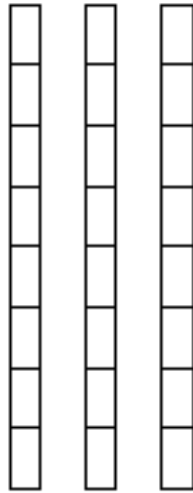

9-pin draft
1 group of 8 dots

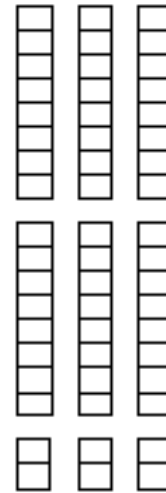

9-pin NLQ
2 groups of 8 dots, 1 group of 2 dots

3. Each group of dots is represented by a byte of data, and each dot within that group has a value as shown below. Add up the value of each dot in the group; the result is the value for the byte of data.

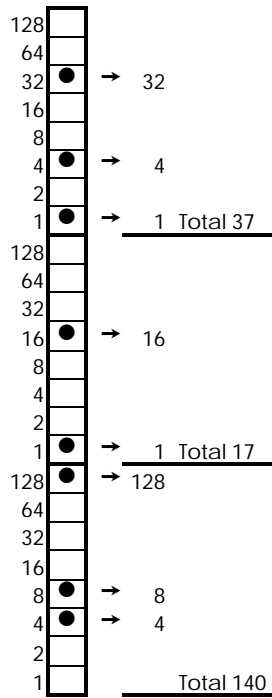

24-pin normal height
(byte values are the same
for super/subscript)

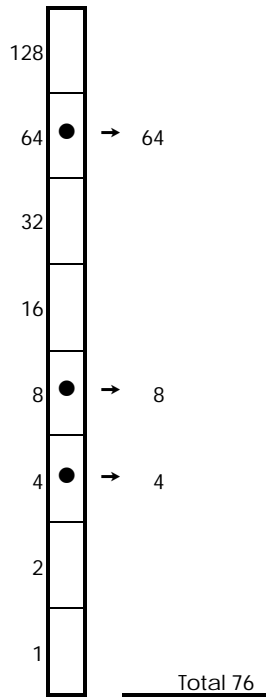

9-pin draft

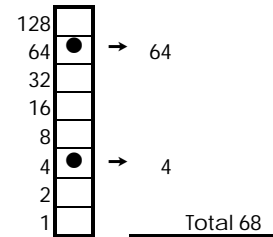
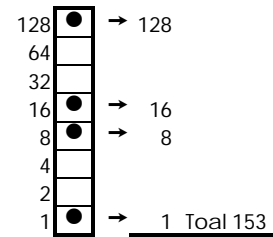

9-pin NLQ

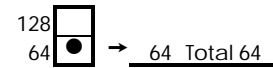

4. Determine the value of the data bytes for all the columns in your design. The printer requires data in the order shown below.

1	4	7	
2	5	8	
3	6	9	

24-pin normal height

1	3	5	
2	4	6	

24-pin super/subscript

1	2	3	
---	---	---	--

9-pin draft

1	4	7	
2	5	8	
3	6	9	

9-pin NLQ

Note:

The printer must receive complete columns of data. In other words, the number of bytes received must be a multiple of 3 for normal-height characters (on 24/48-pin printers) and 9-pin NLQ characters, or a multiple of 2 for super/subscript characters. Draft 9-pin character columns are only 1-byte high.

Deciding where to store data

On 24/48-pin printers, you can copy characters directly into RAM memory in character locations 0 to 127. You can also use the ESC t 2 command to copy the characters you have defined to locations 128 to 255; then you can print all characters, including those at locations normally treated as control codes. See “Switching to RAM character printing” for details.

0	10	20	30	40	50	60	70	80	90	A0	B0	C0	D0	E0	F0
0 NUL	SP	0	@	P	i	p	NUL	SP	0	@	P	i	p		
1 DC1	1	1	A	O	a	q	DC1	1	1	A	O	a	q		
2 DC2	2	2	B	R	b	r	DC2	2	2	B	R	b	r		
3 DC3	3	3	C	S	c	s	DC3	3	3	C	S	c	s		
4 DC4	4	4	D	T	d	t	DC4	4	4	D	T	d	t		
5 %	5	5	E	U	e	u	%	5	5	E	U	e	u		
6 &	6	6	F	V	f	v	&	6	6	F	V	f	v		
7 BEL	7	7	G	W	g	w	BEL	7	7	G	W	g	w		
8 BS CAN	8	8	H	X	h	x	BS CAN	8	8	H	X	h	x		
9 HT EM	9	9	J	Y	j	y	HT EM	9	9	J	Y	j	y		
A LF	A	A	J	Z	j	z	LF	A	A	J	Z	j	z		
B VT ESC	B	B	K	[k	{	VT ESC	B	B	K	[k	{		
C FF	C	C	L	\	l		FF	C	C	L	\	l			
D CR	D	D	M]	m	}	CR	D	D	M]	m	}		
E SO	E	E	N	^	n	~	SO	E	E	N	^	n	~		
F SI	F	F	O	_	o	DEL	SI	F	F	O	_	o	DEL		

On most 9-pin printers, you can copy directly to 241 of the 256 RAM memory locations (you can copy only 6 characters on LX printers, from locations 58 to 63). The following diagram illustrates the memory locations available.

	0	10	20	30	40	50	60	70	80	90	A0	B0	C0	D0	E0	F0
0	NUL	SP	0	@	P	!	q	NUL	SP	0	@	P	!	q		
1	DC1	"	1	A	O	a	q	DC1	"	1	A	O	a	q		
2	DC2	"	2	B	R	b	r	DC2	"	2	B	R	b	r		
3	DC3	#	3	C	S	c	s	DC3	#	3	C	S	c	s		
4	DC4	\$	4	D	T	d	t	DC4	\$	4	D	T	d	t		
5		%	5	E	U	e	u	%	5	E	U	e	u			
6		&	6	F	V	f	v	&	6	F	V	f	v			
7	BEL		7	G	W	g	w	BEL		7	G	W	g	w		
8	BS	CAN	(8	H	X	h	x	BS	CAN	(8	H	X	h	x
9	HT	EM)	9	I	Y	i	y	HT	EM)	9	I	Y	i	y
A	LF	*	*	J	Z	j	z	LF	*	*	J	Z	j	z		
B	VT	ESC	+	K	[k	{	VT	ESC	+	K	[k	{		
C	FF		<	L	\	l		FF		<	L	\	l			
D	CR	-	=	M]	m	}	CR	-	=	M]	m	}		
E	SO	.	>	N	^	n	~	SO	.	>	N	^	n	~		
F	SI	/	?	O	_	o	DEL	SI	/	?	O	_	o	DEL		

The printer normally treats some of these codes as control codes. To print characters you store in these locations, see "Switching to RAM character printing" later in this section.

Sending user-defined characters to the printer

ESC/P 2

ESC/P

For 24/48-pin printers, use the ESC & command to send user-defined data to the printer. The format of the command is:

ESC & NUL n m [a₀ a₁ a₂ d₀ d₁ d₂ . . . d_k]

The value for n is the location of the first consecutive character you wish to redefine; m is the last character. See the ASCII character table in the Appendix for the order of the characters. To define just one character, n is the same as m.

Parameter a₀ specifies the number of blank columns to the left of the character and a₂ the blank columns to the right. The value for a₁ specifies the width of the character you are defining in dot columns.

Repeat the data within the brackets for each character you are defining. You must send a₀, a₁, and a₂ for each character you define. After sending a₀, a₁, and a₂, send the actual dot data for each character, as described in “Preparing data.”

The following example replaces the + character with the following user-defined character:

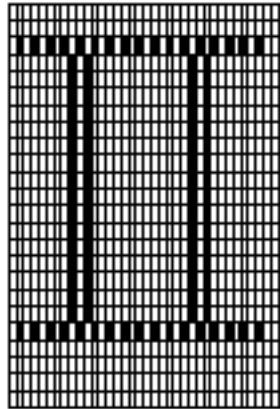

First set the traits. For this character, define a normal height, fixed-pitch, LQ-mode character. The following commands set the traits (see “Setting user-defined character traits”):

ESC x 1	Selects LQ mode
ESC p 0	Cancels proportional spacing
ESC T	Cancels super/subscript
ESC 5	Cancels italic printing

Next, send the data for the character.

The character code of the character being replaced (+) is 43. Set n and m to 43.

Since you will not add any space to the left or right of the character, set the `a0` and `a2` parameters to 0. Since the character width is 34 columns, set `a1` equal to 34. Then send the dot data.

The resulting command is as follows:

```
ESC & 0 43 43 0 34 0
```

The data (102 bytes) is as follows

```
0, 0, 0, 32, 0, 16, 0, 0, 0, 32, 0, 16, 0, 0, 0, 32, 0, 16, 0, 0, 0, 32, 0, 16, 31, 255, 224,
32, 0, 16, 31, 255, 244, 32, 0, 16, 0, 0, 0, 32, 0, 16, 0, 0, 0, 32, 0, 16, 0, 0, 0, 32, 0, 16,
0, 0, 0, 32, 0, 16, 0, 0, 0, 32, 0, 16, 0, 0, 0, 32, 0, 16, 31, 255, 224, 32, 0, 16, 31, 255,
224, 32, 0, 16, 0, 0, 0, 32, 0, 16, 0, 0, 0, 32, 0, 16, 0, 0, 0, 32, 0, 16
```

The character is now stored in location 43, the former + location. You can print the character by switching to RAM printing (see “Switching to RAM character printing”) and then sending code 43 (the + character).

9-Pin ESC/P

Use the ESC & command to send user-defined data to the printer. The format of the command is:

Draft characters: ESC & NUL n m [a d₀ d₁ d₂ . . . d_k]

NLQ-mode characters:ESC & NUL n m [0 a 0 d₀ d₁ d₂ . . . d_k]

The value for `n` is the location of the first consecutive character you wish to redefine; `m` is the last character. See the ASCII character table in the Appendix for the order of the characters. To define just one character, `n` is the same as `m`.

Parameter `a` is called the attribute byte; the purpose of the attribute byte is different for draft and NLQ characters. Both explanations are included below.

The attribute byte for draft 9-pin characters

With draft 9-pin characters, the attribute byte sets the following parameters of the character you are defining:

- The pin group (the upper 8 pins or the lower 8 pins)
 - Select the upper 8 pins if your character has no descenders.
 - Select the lower 8 pins if your character has descenders.
- The beginning column (during proportional spacing)
 - The ending column (during proportional spacing)

This information is stored within the attribute byte as shown below.

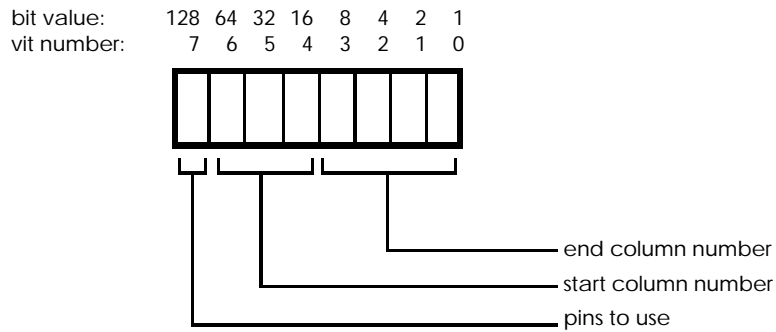

To determine the value of the attribute byte, add up the numbers for the parameters you wish to set.

Attribute byte table

Beginning Column		Ending Column		Upper/Lower 8 pins	
Column number	Value	Column number	Value	Pin group	Value
0	0	1	1	Upper 8 pins	128
1	16	2	2	Lower 8 pins	0
2	32	3	3		
3	48	4	4		
4	64	5	5		
5	80	6	6		
6	96	7	7		
7	112	8	8		
		9	9		
		10	10		
		11	11		

Note:

- The beginning column and ending column settings are only used during proportional spacing. During proportional spacing, the columns to the left of the beginning column and to the right of the ending column are cut off.
- Proportional spacing is not available on LX-series printers.

For example, to define a character that begins in column 2 and ends in 9 (during proportional spacing) and is printed with the upper 8 pins, determine the attribute byte as follows:

	Value	
Beginning column is 2	32	
Ending column is 9	9	
Upper 8 pins	<u>128</u>	
Total attribute byte	= 169	

You must send an attribute byte for each character you define.

The attribute byte for NLQ 9-pin characters

With NLQ characters, the attribute byte determines the width of the character only.

Determine the width of your pattern data in columns (1 to 12) and set the attribute byte equal to the number of columns. Repeat the data within the brackets for each character you are defining. You must send an attribute byte for each character you define.

Examples

The following example replaces the + character with the following 9-pin, draft, user-defined character:

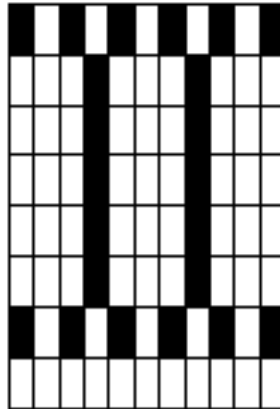

Note:

Only the characters with codes between 58 and 63 may be user-defined on an LX-series printer.

First set the attributes. The following commands do this (see “Setting user-defined character traits”):

ESC x 0 Selects draft mode

ESC 5 Cancels italic printing

Next, send the data for the character. You must select the beginning and ending column if you want to use the character during proportional spacing; also, in this example you will be using the upper 8 pins.

To determine the value of the attribute byte, look at the chart above; your character starts in column 0 and ends in column 10.

	Value
Beginning column is 0	0
Ending column is 10	10
Upper 8 pins	<u>128</u>
Total attribute byte	= 138

Following the attribute byte is the pattern data.

The resulting command is as follows:

```
ESC & 0 43 43 169
```

The data (11 bytes) is as follows:

```
130, 0, 130, 124, 130, 0, 130, 124, 130, 0, 130
```

The command is now stored in location 43, the former + location. You can print the character by switching to RAM printing (see the following section) and then sending code 43 (the + character).

The following example replaces the = character with the following 9-pin NLQ user-defined character:

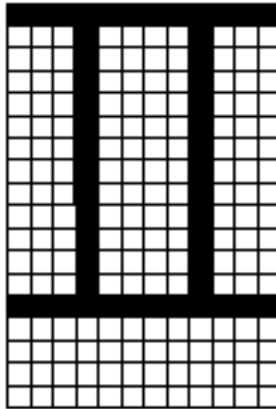

First set the attributes. The following commands do this (see “Setting user-defined character traits”):

```
ESC x 1           Selects NLQ mode
```

```
ESC 5            Cancels italic printing
```

Next, send the data for the character. Since this is an NLQ character, you must set the attribute byte to equal the character width. In this case, the width is 12 columns.

Send the pattern data following the attribute byte. The resulting command is as follows:

```
ESC & 0 61 61 0 12 0
```

The data (36 bytes) is as follows:

```
128, 8, 0, 128, 8, 0, 128, 8, 0, 255, 248, 0, 128, 8, 0, 128, 8, 0, 128, 8, 0, 128, 8, 0, 255, 248, 0, 128, 8, 0, 128, 8, 0, 128, 8, 0
```

The command is now stored in location 61, the former = location. You can print the character by switching to RAM printing (see the following section) and then sending code 61 (the = character).

Switching to RAM character printing

ESC/P 2	ESC/P	9-Pin ESC/P
---------	-------	-------------

Once you store user-defined characters in the printer (using the ESC & command), use the ESC % command to tell the printer to switch to RAM character printing. The format of the command is as follows:

- ESC % 0 Selects ROM characters
- ESC % 1 Selects user-defined characters (RAM memory)

After sending the ESC % 1 command, you can print the characters in the memory locations outlined below:

24/48-pin printer

	0	10	20	30	40	50	60	70	80	90	A0	B0	C0	D0	E0	F0
0	NUL	SP	0	@	P	!	q	NUL	SP	0	@	P	!	q		
1	DC1	1	A	O	a	q	DC1	1	A	O	a	q				
2	DC2	2	B	R	b	r	DC2	2	B	R	b	r				
3	DC3	#	3	C	S	c	s	DC3	#	3	C	S	c	s		
4	DC4	\$	4	D	T	d	t	DC4	\$	4	D	T	d	t		
5	%	5	E	U	e	u	%	5	E	U	e	u				
6	&	6	F	V	f	v	&	6	F	V	f	v				
7	BEL	7	G	W	g	w	BEL	7	G	W	g	w				
8	BS CAN	(8	H	X	h	x	BS CAN	(8	H	X	h	x		
9	HT EM)	9	I	Y	i	y	HT EM)	9	I	Y	i	y		
A	LF	*	A	J	Z	j	z	LF	*	A	J	Z	j	z		
B	VI ESC	+	B	K	[k	{	VI ESC	+	B	K	[k	{		
C	FF	<	C	L	\	l		FF	<	C	L	\	l			
D	CR	=	D	M]	m	}	CR	=	D	M]	m	}		
E	SO	>	E	N	^	n	~	SO	>	E	N	^	n	~		
F	SI	/	F	O	_	o	DEL	SI	/	F	O	_	o	DEL		

9-pin printer

	0	10	20	30	40	50	60	70	80	90	A0	B0	C0	D0	E0	F0
0	NUL 0	SP 16	0 32	0 48	@ 84	P 90	i 96	o 102	NUL 128	SP 144	0 160	@ 176	P 182	i 198	o 204	p 210
1	DC1 1	1 17	1 33	A 49	O 85	a 91	q 97	DC1 113	1 129	1 145	1 161	A 167	O 173	a 179	q 185	
2	DC2 2	2 18	2 34	B 50	R 86	b 92	r 98	DC2 114	2 130	2 146	2 162	B 168	R 174	b 180	r 186	
3	DC3 3	3 19	3 35	C 51	S 87	c 93	s 99	DC3 115	3 131	3 147	3 163	C 169	S 175	c 181	s 187	
4	DC4 4	4 20	4 36	D 52	T 88	d 94	t 100	DC4 116	4 132	4 148	4 164	D 170	T 176	d 182	t 188	
5	5 21	5 21	5 37	E 53	U 89	e 95	u 101	5 117	5 133	5 149	5 165	E 171	U 177	e 183	u 189	
6	6 22	6 22	6 38	F 54	V 90	f 96	v 102	6 118	6 134	6 150	6 166	F 172	V 178	f 184	v 190	
7	BEL 7	7 23	7 39	G 55	W 91	g 97	w 103	BEL 119	7 135	7 151	7 167	G 173	W 179	g 185	w 191	
8	BS 8	CAN 24	8 40	H 56	X 92	h 98	x 104	BS 120	CAN 136	8 152	8 168	H 174	X 180	h 186	x 192	
9	HT 9	EM 25	9 41	I 57	Y 93	i 99	y 105	HT 121	EM 137	9 153	9 169	I 175	Y 181	i 187	y 193	
A	LF 10	26	* 42	J 58	Z 94	j 100	z 106	LF 122	104	10	170	J 176	Z 182	j 188	z 194	
B	VT 11	ESC 27	+ 43	K 59	[95	k 101	{ 107	VT 123	ESC 139	11	171	K 177	[183	k 189	{ 195	
C	FF 12	28	< 44	L 60	\ 96	l 102	 108	FF 124	140	12	172	L 178	\ 184	l 190	 196	
D	CR 13	29	= 45	M 61] 97	m 103	} 109	CR 125	141	13	173	M 179] 185	m 191	} 197	
E	SO 14	30	> 46	N 62	^ 98	n 104	~ 110	SO 126	142	14	174	N 180	^ 186	n 192	~ 198	
F	SI 15	31	? 47	O 63	_ 99	o 105	DEL 111	SI 127	143	15	175	O 181	_ 187	o 193	DEL 199	

The method of accessing characters in other areas varies depending on the type of printer.

There are two ways to access user-defined characters 0 to 31.

ESC/P 2

The first method is available only on ESC/P 2 printers. After changing to RAM characters with the ESC % 1 command, use the ESC (^ command to send character data. All data sent with the ESC (^ command is treated as character data. See ESC (^ in the Command Summary for details.

The table of accessible characters is as follows:

	0	10	20	30	40	50	60	70	80	90	A0	B0	C0	D0	E0	F0
0	NUL	SP	0	@	P	!	0	NUL	SP	0	@	P	!	0	@	P
1	DC1	1	A	Q	a	q	DC1	!	1	A	Q	a	q	DC1	!	1
2	DC2	2	B	R	b	r	DC2	"	2	B	R	b	r	DC2	"	2
3	DC3	#	C	S	c	s	DC3	#	3	C	S	c	s	DC3	#	3
4	DC4	\$	D	T	d	t	DC4	\$	4	D	T	d	t	DC4	\$	4
5	%	5	E	U	e	u	%	5	E	U	e	u	%	5	E	U
6	&	6	F	V	f	v	&	6	F	V	f	v	&	6	F	V
7	BEL	7	G	W	g	w	BEL	7	G	W	g	w	BEL	7	G	W
8	BS	CAN	(8	H	X	h	x	BS	CAN	(8	H	X	h	x
9	HT	EM)	9	J	Y	j	y	HT	EM)	9	J	Y	j	y
A	LF	*	10	J	Z	j	z	LF	*	10	J	Z	j	z	LF	*
B	VT	ESC	+	11	K	[k	{	VT	ESC	+	11	K	[k	{
C	FF	<	12	L	\	l	12	L	\	l	12	L	\	l	12	L
D	CR	=	13	M]	m	13	M]	m	13	M]	m	13	M
E	SO	>	14	N	^	n	14	N	^	n	14	N	^	n	14	N
F	SI	/	15	O	_	o	15	O	_	o	15	O	_	o	15	O

The second method is to select ESC % 0 (ROM character printing) and then send the ESC t 2 command. ESC t 2 copies all user-defined characters to the upper half of the character memory, and leaves the lower half as ROM characters. (In other words, the ESC t 2 command adds 128 to the user-defined character codes.)

	0	10	20	30	40	50	60	70	80	90	A0	B0	C0	D0	E0	F0
0	NUL		SP	0	@	P	t	p	NUL		SP	0	@	P	t	p
1	DC1		"	1	A	Q	a	q	DC1		"	1	A	Q	a	q
2	DC2		"	2	B	R	b	r	DC2		"	2	B	R	b	r
3	DC3		#	3	C	S	c	s	DC3		#	3	C	S	c	s
4	DC4		\$	4	D	T	d	t	DC4		\$	4	D	T	d	t
5			%	5	E	U	e	u			%	5	E	U	e	u
6			&	6	F	V	f	v			&	6	F	V	f	v
7	REL		'	7	G	W	g	w	REL		'	7	G	W	g	w
8	BS	CAN	(8	H	X	h	x	BS	CAN	(8	H	X	h	x
9	HT	EM)	9	I	Y	i	y	HT	EM)	9	I	Y	i	y
A	LF		*	:	J	Z	j	z	LF		*	:	J	Z	j	z
B	VT	ESC	+	;	K	[k	{	VT	ESC	+	;	K	[k	{
C	FF		<		L	\	l		FF		<		L	\	l	
D	CR		=		M]	m	}	CR		=		M]	m	}
E	SO		>		N	^	n	~	SO		>		N	^	n	~
F	SI		?		O	_	o	DEL	SI		?		O	_	o	DEL

The codes between 128 and 159, as well as between 0 and 31, are usually treated as control codes. Send the ESC I and ESC 6 commands to access characters 128 to 159 and the 18 non-control codes between 0 and 31.

The table of accessible characters then appears as below:

	0	10	20	30	40	50	60	70	80	90	A0	B0	C0	D0	E0	F0
0	NUL		SP	0	@	P		p	NUL		SP	0	@	P		p
1	DC1		1	A	O	a		q	DC1		1	A	O	a		q
2	DC2		2	B	R	b		r	DC2		2	B	R	b		r
3	DC3		3	C	S	c		s	DC3		3	C	S	c		s
4	DC4		4	D	T	d		t	DC4		4	D	T	d		t
5		%	5	E	U	e		u	%	5	E	U	e		u	
6		&	6	F	V	f		v	&	6	F	V	f		v	
7	REL		7	G	W	g		w	REL		7	G	W	g		w
8	BS CAN	(8	H	X	h		x	BS CAN	(8	H	X	h		x
9	HT EM)	9	I	Y	i		y	HT EM)	9	I	Y	i		y
A	LF	*		J	Z	j		z	LF	*		J	Z	j		z
B	VT ESC	+		K	[k		{	VT ESC	+		K	[k		{
C	FF	<		L	\	l			FF	<		L	\	l		
D	CR	=		M]	m		}	CR	=		M]	m		}
E	SO	>		N	^	n		~	SO	>		N	^	n		~
F	SI	/		O	_	o		DEL SI	SI	/		O	_	o		DEL SI

Selecting an international character set

ESC/P 2

ESC/P

9-Pin ESC/P

You can change up to 12 of the characters in the current character table with the ESC R command. These 12 characters are called international character sets because they correspond to characters commonly used in several foreign languages.

The format for this command is as follows:

ESC R n

The parameter n determines which character set is selected.

The table below shows these characters and their codes in the Helvetica typeface, as well as the value of the parameter used in the ESC R command to select each character set.

n	Set name	Dec Hex	35 23	36 24	64 40	91 5B	92 5C	93 5D	94 5E	96 60	123 7B	124 7C	125 7D	126 7E
0	USA	#	\$	@	[\]	^	`	{		}	~	
1	France	#	\$	à	°	ç	§	^	`	é	ù	è	¨	
2	Germany	#	\$	§	Ä	Ö	Ü	^	`	ä	ö	ü	ß	
3	UK	£	\$	@	[\]	^	`	{		}	~	
4	Denmark I	#	\$	@	Æ	Ø	Å	^	`	æ	ø	å	~	
5	Sweden	#	¤	É	Ä	Ö	Å	Ü	é	ä	ö	å	ü	
6	Italy	#	\$	@	°	\	é	^	ù	à	ò	è	ì	
7	Spain I	Pt	\$	@	ı	Ñ	ı	^	`	¨	ñ	}	~	
8	Japan (Eng)	#	\$	@	[¥]	^	`	{		}	~	
9	Norway	#	¤	É	Æ	Ø	Å	Ü	é	æ	ø	å	ü	
10	Denmark II	#	\$	É	Æ	Ø	Å	Ü	é	æ	ø	å	ü	
11	Spain II	#	\$	á	ı	Ñ	ı	é	`	ı	ñ	ó	ú	
12	Lat America	#	\$	á	ı	Ñ	ı	é	ü	ı	ñ	ó	ú	
13	Korea	#	\$	@	[₩]	^	`	{		}	~	
64	Legal	#	\$	§	°	'	"	¶	`	©	®	†	™	

Select a Font

ESC/P 2

ESC/P

9-Pin ESC/P

ESC/P 2 includes the ESC X command for selecting scalable fonts; differences in handling scalable fonts are discussed in each section.

The term font is often confused with typeface. Because the electronic printer field has evolved from basic beginnings, these two terms have often been used interchangeably.

However, fonts are defined by six attributes:

Attributes	ESC/P 2	Previous ESC/P levels
Character table	ESC t, ESC (t	ESC t
Point size (height)	ESC X	ESC w
Typeface	ESC k	ESC k
Pitch (proportional/fixed spacing)	ESC X, ESC c	ESC P, M, g, p, W, ESC SP, SO, SI, DC2, DC4
Style (italics/normal)	ESC 4, ESC 5	ESC 4, ESC 5
Weight (bold/normal)	ESC E, ESC F	ESC E, ESC F

Each time you change one of the above attributes, the printer selects a new font. If a font matching the selected attributes is not available in the printer's ROM memory, the printer manufactures a temporary font with those attributes.

You can set these attributes in any order; changing one attribute does not affect any other attribute. However, the printer selects fonts internally in the above order, so using that order is the most efficient.

You can modify each font with several enhancements, as follows:

Double-strike ESC G, ESC H

Score ESC (-, ESC -

Shadow/outline ESC q

Print quality (draft, LQ, or NLQ)

ESC/P 2

ESC/P

9-Pin ESC/P

The following attributes are limited during draft printing:

- Typeface Draft typeface only
- Point size 10.5 and 21-point sizes only

Use the ESC x command to select the print quality, according to the following format:

ESC x 0	Selects draft print quality
ESC x 1	Selects LQ print quality for ESC/P 2 and ESC/P Selects NLQ print quality for 9-Pin ESC/P

Standard and scalable fonts (multipoint mode)

ESC/P 2

ESC/P

9-Pin ESC/P

Both ESC/P 2 and previous ESC/P level printers can print the standard 10.5-point fonts. You can modify the point size (height) and pitch of these characters with the following commands:

<i>Size</i>	
SO, ESC W	Double-width printing
ESC w	Double-height printing
SI	Condensed printing
 <i>Spacing</i>	
ESC P	Select 10 cpi
ESC M	Select 12 cpi
ESC g	Select 15 cpi (24/48-pin printers only)
ESC p	Select proportional spacing
ESC SP	Add additional space between characters

By using ESC/P 2's ESC X command to enter multipoint mode, you can select scalable fonts. Scalable fonts allow you to directly specify the point size and pitch of your characters.

Not all typefaces are available in multipoint mode; see the Command Table for the typefaces available in multipoint mode on each printer.

During multipoint mode, sending the commands below results in the following:

Commands ignored		Commands that cancel multipoint mode	
ESC W	Double-width	ESC P	Select 10 cpi
ESC w	Double-height	ESC M	Select 12 cpi
ESC SP	Additional space	ESC g	Select 15 cpi
SI	Condensed printing	ESC p	Select proportional
SO	Double-width	ESC !	Master select
DC2	Cancel condensed	ESC @	Reset
DC4	Cancel double-width		
ESC k	(if typeface is not available in multipoint mode)		

Selecting the character table

Use the ESC t command to select the character table. The format for this command is as follows:

ESC t n

The parameter n is the number of the character table.

ESC/P 2

With ESC/P 2, you can select from four active character tables. See “Assign character tables” for details.

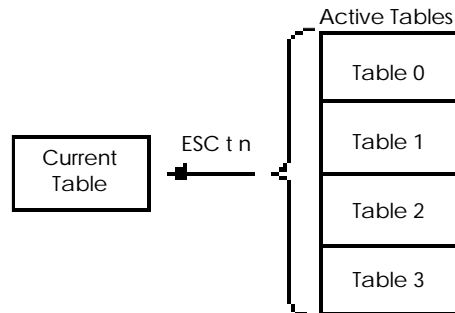

ESC/P

9-Pin ESC/P

With previous ESC/P versions, you can select from two character tables: italics and graphics.

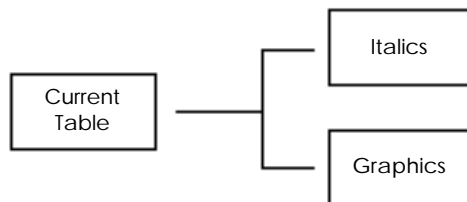

The character table is one attribute of the font. Selecting a different character table selects a different font.

Selecting the point size

The height of characters is measured in points. One point is equal to 1/72 inch.

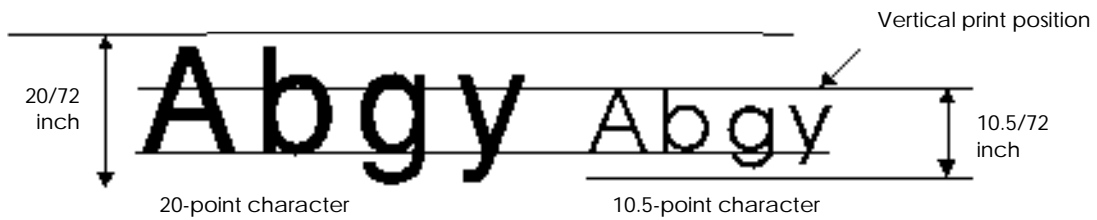

ESC/P 2

If you plan to use typefaces available in multipoint mode, you can set the point size with the ESC X command. This command puts the printer in multipoint mode and sets the point and pitch of the font.

The format of the ESC X command is as follows:

ESC X m n_L n_H

The m parameter sets the pitch and the n_L and n_H parameters set the point size, according to the following formulas:

Pitch m = 0 the pitch does not change; use this value if you plan to change only the point size.

 1 proportional spacing is selected.

m ≥ 5 $\frac{360}{m}$ cpi character spacing

Point size

$$(\text{point size}) = \frac{(n_H \times 256) + n_L}{2}$$

If n_H and n_L both equal 0, the point size does not change; use these values if you plan to change only the pitch.

ABCDefgh12345!@#\$\$%^

32 points

ABCDefgh12345!@#\$\$%^

26 points

ABCDefgh12345!@#\$\$%^

20 points

ABCDefgh12345!@#\$\$%^

14 points

ABCDefgh12345!@#\$\$%^

8 points

ABCDefgh12345!@#\$\$%^

30 points

ABCDefgh12345!@#\$\$%^

24 points

ABCDefgh12345!@#\$\$%^

18 points

ABCDefgh12345!@#\$\$%^

12 points

Note:

- Some commands are ignored during multipoint mode and some commands cancel multipoint mode. See the list in “Standard and scalable fonts (multipoint mode).”
- You can select characters equivalent to previous ESC/P levels by adjusting the point and pitch with the ESC X command. See the Appendix for details.
- The baseline of all characters is 20/180 inch below the current vertical print position. See “Selecting the print position.”

Non-ESC/P 2 and typefaces not available in multipoint mode

Characters normally have a size of 10.5 points. You can also print 21-point characters as shown below.

ESC w 1 Selects double-height (21-point) characters

ESC w 0 Selects normal (10.5-point) characters

Selecting the typeface

Select the typeface using the ESC k command. The parameters for selecting each available typeface setting are shown below:

Command	Typeface name	Character samples (24-pin)
ESC k 0	Roman	abcdefghijklmnopqrstuvwxyz
ESC k 1	Sans serif	abcdefghijklmnopqrstuvwxyz
*ESC k 2	Courier	abcdefghijklmnopqrstuvwxyz
*ESC k 3	Prestige	abcdefghijklmnopqrstuvwxyz
*ESC k 4	Script	<i>abcdefghijklmnopqrstuvwxyz</i>
*ESC k 5	OCR-B	abcdefghijklmnopqrstuvwxyz
*ESC k 6	OCR-A	abcdefghijklmnopqrstuvwxyz
*ESC k 7	Orator	ABCDEFGHIJKLMNopqrstuvwxyz
*ESC k 8	Orator-S	abcdefghijklmnopqrstuvwxyz
*ESC k 9	Script C	<i>abcdefghijklmnopqrstuvwxyz</i>

*Only available on 24/48-pin printers

Note:

Not all typefaces are available in multipoint mode; see the Feature Summary for the typefaces available in multipoint mode.

Selecting the pitch

ESC/P 2

ESC/P 2 provides two ways of setting the pitch: the ESC X command and the ESC c command.

If you plan to use multipoint mode typefaces, you can set the pitch with the ESC X command. This command puts the printer in multipoint mode and sets the pitch and point size of the font.

The format of the ESC X command is as follows:

ESC X m n_L n_H

The m parameter sets the pitch and the n_L and n_H parameters set the point size, according to the following formulas:

Pitch m = 0 The pitch does not change

 1 Proportional spacing is selected

 m ≥ 5 $\frac{360}{m}$ cpi character spacing

Point size

$$(\text{point size}) = \frac{(n_H \times 256) + n_L}{2}$$

If n_H and n_L both equal 0, the point size does not change; use this value if you plan to change only the pitch.

See the section on proportional character width during multipoint mode in the Appendix.

Note:

- Some commands are ignored during multipoint mode and some commands cancel multipoint mode. See the list in “Standard and scalable fonts (multipoint mode).”
- You can select characters equivalent to previous ESC/P levels by adjusting the point and pitch with the ESC X command. See the Appendix for details.

You can also set the pitch with the ESC c command. This command sets the horizontal motion index (HMI) in inches per character rather than in cpi. The format of this command is as follows:

ESC c n_L n_H

$$\text{HMI} = \frac{(n_H \times 256) + n_L}{360} \text{ inch}$$

$$n_H = \text{INT} \frac{\text{HMI} \times 360}{256}$$

$$n_L = \text{MOD} \frac{\text{HMI} \times 360}{256}$$

The HMI set with the ESC c command cancels the pitch set with the ESC X command.

The following commands cancel the HMI set with the ESC c command:

ESC W	Double-width	ESC P	Select 10 cpi
ESC M	Select 12 cpi	ESC w	Double-height
ESC SP	Additional space	ESC g	Select 15 cpi
SI	Condensed printing	ESC p	Select proportional
SO	Double-width	ESC !	Master select
DC2	Cancel condensed	ESC @	Reset
DC4	Cancel double-width	ESC X	Select pitch and point

ESC/P 2

ESC/P

9-Pin ESC/P

Non-ESC/P 2 printers and typefaces not available in multipoint mode

For previous ESC/P-level printers, as well as ESC/P 2 printers that are not in multipoint mode, you can adjust the character pitch by setting the following features:

Proportional spacing	10-cpi character spacing
12-cpi character spacing	15-cpi character spacing
Condensed printing	Intercharacter spacing
Double-width printing	

The following commands produce the fixed pitches indicated:

Pitch	Individual commands	Master Select
5 cpi	ESC W 1, ESC P	ESC ! 32
6 cpi	ESC W 1, ESC M	ESC ! 33
7.5 cpi*	ESC W 1, ESC g	ESC ! 32, ESC g
10 cpi	ESC P	ESC ! 0
12 cpi	ESC M	ESC ! 1
15 cpi*	ESC g	N/A
17 cpi	ESC P, SI	ESC ! 4
20 cpi	ESC M, SI	ESC ! 5

*These pitches are not available on 9-pin printers.

Note:

- When you select the 7.5-cpi and 15-cpi pitches the character height is reduced on most printers.
- See ESC ! (the Master Select command) in the Command Summary.

Use the ESC p command to select proportional spacing. In this type of spacing, the character width varies by character; thin characters like t receive less space than wide characters like M. The format for this command is as follows:

Individual command	Master select	
ESC p 1	ESC ! 2	Selects proportional spacing
ESC p 0	N/A	Cancel proportional spacing

See the proportional width table in the Appendix for the exact width of proportional width characters.

A final way you can adjust the pitch is with the ESC SP command. Use this command to add a fixed amount of space to the right of every character. The format of this command is as follows:

ESC SP n

The additional space is either n/120 inch or n/180 inch, depending on the current printer settings; see ESC SP in the Command Summary for details. This additional space is added to both fixed-pitch and proportional characters.

Selecting the style



The term style refers to whether a character is upright or italic. Select the style attribute with the ESC 4 or ESC 5 commands.

ESC 4 Select italic printing
ESC 5 Cancel italic printing (Select upright printing)

ABCDEFGHI JKLMnopqrst uvwxyz
Upright

ABCDEFGHI JKLMnopqrst uvwxyz
Italic

Note:

You cannot italicize graphics characters.

Selecting the weight



The term weight refers to the thickness (or boldness) of printed lines in a character. Set the weight attribute with the ESC E and ESC F commands.

ESC E	Sets the weight attribute to bold
ESC F	Sets the weight attribute to normal (cancels bold)

ABCDEFGHIJKLMnopqrstuvwxyz

Normal

ABCDEFGHIJKLMnopqrstuvwxyz

Bold

Enhancements



To modify fonts, several enhancements are available: double-strike, shadow, outline, and scoring.

On 9-pin printers, the only enhancement available is double-strike (only during draft printing) and single, continuous, and underline scoring.

These are not attributes of a font and do not affect font definition. These enhancements can be applied to both multipoint and normal fonts.

Double-strike



The double-strike feature produces bolder printing by striking each dot twice. The commands for this feature are as follows:

ESC G	Selects double-strike printing
ESC H	Cancels double-strike printing

Note:

On 9-pin printers, NLQ-mode overrides double-strike; double-strike resumes when the printer returns to draft printing.

ABCDEFGHIJKLMnopqrstuvwxyz

Normal

ABCDEFGHIJKLMnopqrstuvwxyz

Double-strike

Shadow/outline

ESC/P 2

ESC/P

The shadow and outline enhancements are available only on 24/48-pin printers.

ABCDEFGHI JKLMnopqrstuvwxy^z

Normal

ABCDEFGHI JKLMnopqrstuvwxy^z

Outline

ABCDEFGHI JKLMnopqrstuvwxy^z

Shadow

ABCDEFGHI JKLMnopqrstuvwxy^z

Outline and shadow

The command for shadow/outline printing is ESC q; the format is as follows:

ESC q 0	Turn off outline/shadow printing
ESC q 1	Turn on outline printing
ESC q 2	Turn on shadow printing
ESC q 3	Turn on both outline and shadow printing

Note:

This command does not affect graphics characters.

Score

ESC/P 2

ESC/P

9-Pin ESC/P

Several types of scoring are available on 24/48-pin printers, as shown below:

ABCDEFGHIjklmno

ABCDEFGHIjklmno

ABCDEFGHIjklmno

ABCDEFGHIjklmno

ABCDEFGHIjklmno

ABCDEFGHIjklmno

ABCDEFGHIjklmno

ABCDEFGHIjklmno

ABCDEFGHIjklmno

ABCDEFGHIjklmno

ABCDEFGHIjklmno

ABCDEFGHIjklmno

Note:

You can use the ESC- command to select single, continuous underlining on 9-pin printers. This is the only type of scoring available on 9-pin printers.

The command for selecting scoring is ESC (-, and its format and combinations are as follows:

ESC (- 3 0 1 n₁ n₂

n₁ = 1 Underline
2 Strikethrough
3 Overscore

n₂ = 0 Turn off scoring
1 Single continuous line
2 Double continuous line
5 Single broken line
6 Double broken line

Note:

- Each type of scoring is independent of other types; any combination of scoring can be set simultaneously.
- The score is printed in the currently selected print quality and is affected by the bold and double-strike commands.
- You cannot score graphics characters.

Super/subscript

ESC/P 2

ESC/P

9-Pin ESC/P

The super/subscript command prints characters at approximately two-thirds the currently selected point size.

Superscript characters are printed in the upper two-thirds of the normal character space; subscript characters are printed in the lower two-thirds.

Super/subscript is available in both normal and multipoint modes.

Following are examples of super/subscript characters.

B^D B_D b^d b_d

B^D B_D b^d b_d

B^D B_D b^d b_d

The commands for super/subscript printing and their format is as follows:

ESC S 1	Selects subscript printing
ESC S 0	Selects superscript printing
ESC T	Cancels super/subscript printing

Note:

- You cannot print graphics characters as super/subscript characters.
- See “Proportional character widths” in the Appendix for information on the proportional width of super/subscript characters.
- During underline printing, the underline strikes through the descenders on subscript characters.
- During multipoint mode, the available point size nearest to two-thirds the size of the current font is selected for super/subscript characters.
- If the current point size is 8 points, super/subscript character size is not reduced.

Select Supporting Features

Other features that affect the appearance of characters and graphics are unidirectional and color printing.

Selecting unidirectional print head movement

ESC/P 2 ESC/P 9-Pin ESC/P

Normally, printing is bidirectional. Although the print head positions dots very accurately, print head movement has a slight effect on dot position. This effect is sometimes noticeable when printing graphics that include continuous vertical lines or large point-size characters.

To achieve maximum alignment accuracy, use the unidirectional feature. During unidirectional printing, the print head prints only from left to right.

Select unidirectional printing as follows:

ESC U 0	Selects bidirectional printing (cancels unidirectional)
ESC U 1	Selects unidirectional printing

Selecting print color

ESC/P 2 ESC/P 9-Pin ESC/P

Use the ESC r command to select the print color on printers capable of color printing.

The format of the ESC r command is as follows:

ESC r 0	Black
ESC r 1	Magenta
ESC r 2	Cyan
ESC r 3	Violet
ESC r 4	Yellow
ESC r 5	Red
ESC r 6	Green

Note:

- Printers not capable of color printing ignore this command.
- Other colors are possible by overprinting the above colors. When combining yellow with other colors, always print yellow dots first (this prevents soiling of the print side of the ribbon).
- ESC/P 2 printers can print only black, magenta, cyan, and yellow during graphics mode.
- When printing in extended graphics mode selected with the ESC . 2 command, use the binary mode command <COLR> to select the color. Extended graphics mode is only available on the Stylus COLOR and later high-resolution printer models. For more information, see “Extended ESC/P 2 Programming Guide” later in this section.

Select the Print Position



The definition of the vertical print position differs for text and graphics printing.

Physically, the print position corresponds to the top pin in the print head when graphics or 10.5-point characters are printed. However, to assure that the baseline of all characters is the same, the baseline is defined as 20/180 inch (7/72 inch for 9-pin printers) below the vertical print position no matter what point-size characters you are printing.

Text printing The baseline of the character is printed 20/180 inch (7/72 inch for 9-pin printers) below the vertical print position; the left-most column of the characters is printed at the horizontal position.

Graphics printing The print position is the top printable row of dots.

The following diagram illustrates the relationship between the print head and the text/graphics print position.

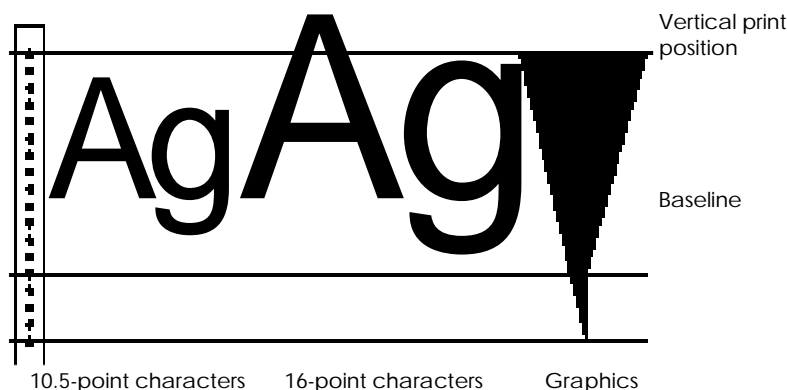

ESC/P 2 has new commands that allow for easier vertical and horizontal movement of the print position.

These new commands are:

ESC (U	Sets a unit that is used for moving the print position and setting the page format
ESC (V	Sets the absolute vertical position on the page
ESC (v	Sets the relative vertical position on the page

Horizontal movement is performed with commands available in previous ESC/P versions. However, now the increment of movement is the unit set with the ESC (U command.

ESC \$	Sets the absolute horizontal position
ESC \	Sets the relative horizontal position

The following sections describe moving the print position, with explanations for both ESC/P 2 and previous ESC/P versions.

Moving the horizontal position

The horizontal print position is defined as the position where the left-most printable column of dots is printed for the next character or graphics design.

When you print characters or spaces, the printer automatically moves the print position according to the pitch you select (or the width of each character if you select proportional spacing).

To move the the horizontal print position independent of character printing, the recommended commands are as follows:

ESC \$	Set the absolute horizontal position
ESC \	Set the relative horizontal position
HT	Horizontal tab

The format of the ESC \$ command is as follows:

ESC \$ n_L n_H

The resulting horizontal position is determined by the formula below.

(horizontal position) = ((n_H × 256) + n_L) × (defined unit) + (left margin)

$$n_H = \text{INT} \left(\frac{((\text{horizontal position}) - (\text{left-margin position})) \times \frac{1}{(\text{defined unit})}}{256} \right)$$

$$n_L = \text{MOD} \left(\frac{((\text{horizontal position}) - (\text{left-margin position})) \times \frac{1}{(\text{defined unit})}}{256} \right)$$

The defined unit varies as follows:

ESC/P 2 printers The unit defined with the ESC (U command
 Non-ESC/P 2 printers 1/60 inch

The format of the ESC \ command is as follows:

ESC \ n_L n_H

The horizontal position is determined by the formula below.

$$(\text{horizontal position}) = ((n_H \times 256) + n_L) \times (\text{defined unit}) + (\text{current position})$$

To move to the right of the current print position

$$n_H = \text{INT} \left(\frac{((\text{horizontal position}) - (\text{current position})) \times \frac{1}{(\text{defined unit})}}{256} \right)$$

$$n_L = \text{MOD} \left(\frac{((\text{horizontal position}) - (\text{current position})) \times \frac{1}{(\text{defined unit})}}{256} \right)$$

To move to the left of the current print position

$$n_H = 32768 - \text{INT} \left(\frac{((\text{current position}) - (\text{horizontal position})) \times \frac{1}{(\text{defined unit})}}{256} \right)$$

$$n_L = 32768 - \text{MOD} \left(\frac{((\text{current position}) - (\text{horizontal position})) \times \frac{1}{(\text{defined unit})}}{256} \right)$$

The defined unit varies as follows:

ESC/P 2 printers The unit defined with the ESC (U command
 Non-ESC/P2,

24/48-pin printers

 LQ mode 1/180 inch

 Draft mode 1/120 inch

9-pin printers 1/120 inch

Note:

- These commands have no effect on the vertical print position.
- The printer ignores commands that would move the print position outside the left or right margins.
- Character scoring (underline, overscore, and strikethrough) is not performed between the current and final print positions when the ESC \$ command is used. Scoring is also not performed if the ESC \ command moves the print position in the negative direction.

You can also use the tab command to move the horizontal print position to the next tab position.

First set the tabs with the ESC D command. The format of the ESC D command is as follows:

```
ESC D n1 n2 . . . nk NUL
```

Sets horizontal tab positions (in the current character pitch) at the columns specified by n₁ to n_k, as measured from the left-margin position

Note:

- The values for n must be in ascending order; a value of n less than the previous n ends tab setting (just like the NUL code).
- Changing the character pitch does not affect current tab settings.
- Send an ESC D NUL command to cancel all tab settings.
- The tab settings move to match any movement in the left margin.
- A maximum of 32 horizontal tabs can be set.
- The printer does not move the print position to any tabs beyond the right-margin position. However, all tab settings are stored in the printer's memory; if you move the right margin, you can access previously ignored tabs.
- The printer calculates tab positions based on 10 cpi if proportional spacing is selected with the ESC p command.
- Sending the ESC D command clears any previous tab settings.

Sending the HT command moves the print position to the next tab position to the right of the current position.

Note:

- The HT command has no effect on the vertical print position.
- The printer ignores an HT command that would move the print position outside (to the right of) the right-margin position.
- Character scoring (underline, overscore, and strikethrough) is not performed between the current and final print positions when the HT command is sent.

Moving the vertical position

ESC/P 2

For ESC/P 2 printers, the vertical print position is defined as follows:

- The position 20/180 inch above the baseline during character printing
- The position of the top printable row of dots during graphics printing

Note:

When setting the vertical print position, you must place enough room at the top and bottom of a page for a full character to print.

If the point size is larger than 10.5 points, and the print position is near the top or bottom-margin position, part of the character may print outside the printing area (above the top-margin or below the bottom-margin position). The printer prints the full character, even though it falls outside the printing area, with the following exception:

If part of the character falls outside the printable area on single-sheet paper (closer than 8.5 mm to the top edge or closer than 13.5 mm to the bottom edge), that part is not assured.

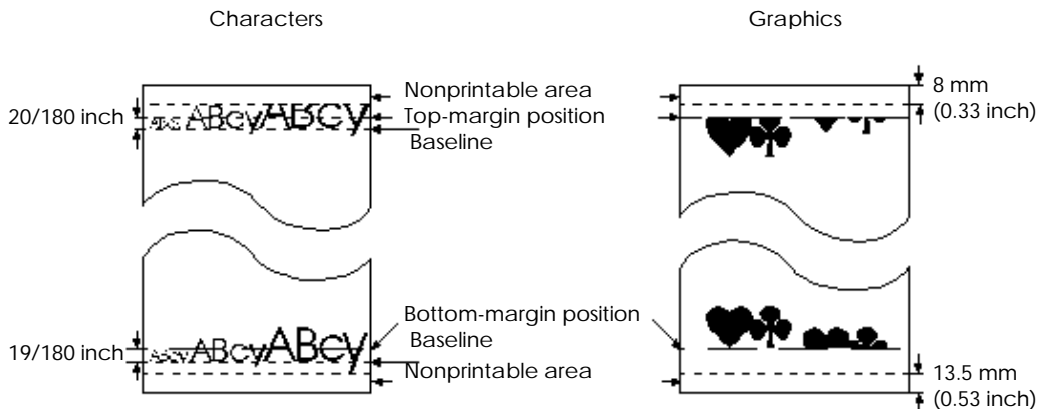

Note:

- Always set the vertical print position so sufficient room is provided for the full character to print.
- Graphics data falling outside the printing area is ignored.

New commands are available in ESC/P 2 that simplify setting the vertical print position. These commands are:

ESC (V	Set absolute vertical print position
ESC (v	Set relative vertical print position

The unit of movement for both these commands is the unit set with the ESC (U command. See ESC (U in the Command Summary and “Setting the page length” for more information.

The format for the ESC (V command is as follows:

ESC (V 2 0 m_L m_H

The resulting vertical position is determined by the following formula:

(vertical position) = ((m_H × 256) + m_L) × (defined unit) + (top-margin position)

$$m_H = \text{INT} \left(\frac{((\text{vertical position}) - (\text{top-margin position})) \times \frac{1}{(\text{defined unit})}}{256} \right)$$

$$m_L = \text{MOD} \left(\frac{((\text{vertical position}) - (\text{top-margin position})) \times \frac{1}{(\text{defined unit})}}{256} \right)$$

The format for the ESC (v command is as follows:

ESC (v 2 0 m_L m_H

(horizontal position) = ((m_H × 256) + m_L) × (defined unit) + (current position)

To move in the positive direction (down the page), the formula is as follows:

$$m_H = \text{INT} \left(\frac{((\text{vertical position}) - (\text{current position})) \times \frac{1}{(\text{defined unit})}}{256} \right)$$

$$m_L = \text{MOD} \left(\frac{((\text{vertical position}) - (\text{current position})) \times \frac{1}{(\text{defined unit})}}{256} \right)$$

To move in the negative direction (up the page), the formula is as follows:

$$m_H = 32768 - \text{INT} \left(\frac{((\text{current position}) - (\text{vertical position})) \times \frac{1}{(\text{defined unit})}}{256} \right)$$

$$m_L = 32768 - \text{MOD} \left(\frac{((\text{current position}) - (\text{vertical position})) \times \frac{1}{(\text{defined unit})}}{256} \right)$$

Note:

- These commands have no effect on the horizontal print position.
- The printer ignores the ESC (v command if it would move the print position above the top margin.
- If a command would move the print position below the bottom margin position, the print position moves to the top-margin position on the following page.
- You cannot move the print position more than 179/360 inch in the negative direction from the current print position.
- The printer ignores this command under the following conditions:
 - The command would move the print position more than 179/360inch in the negative direction
 - The command would move the print position in the negative direction after a graphics command is sent on the current line
 - The command would move the print position in the negative direction beyond the position of any previous graphics printing

ESC/P 2

9-Pin ESC/P

For Non-ESC/P 2 printers, the vertical position is defined as follows:

- The position 20/180 inch (7/72 inch for 9-pin printers) above the baseline during character printing
- The position of the top printable row of dots during graphics printing

The following commands are recommended for moving the vertical print position within a page.

ESC J	Advance the print position vertically
LF	Line feed

The format for the ESC J command is as follows:

ESC J n

This command moves the paper forward according to the following formula.

24/48-pin printers	(distance down) = n/180 inches
9-pin printers	(distance down) = n/216 inches

This command has no effect on the horizontal print position.

The LF command affects both the vertical and horizontal positions. Sending the LF command performs the following functions:

- Moves the print position one line forward in the currently selected line spacing
- Moves the horizontal print position to the left-margin position

Note:

Paper handling at the end of a page differs depending on paper type, loading method, and ESC/P version.

ESC/P 2

Continuous paper	If an ESC J, LF, ESC (V, or ESC (v command would move the print position below the bottom margin position, the printer moves the print position to the top-margin position on the following page.
Single-sheet paper	If an ESC J, LF, ESC (V, or ESC (v command would move the print position below the bottom-margin position, the printer ejects the sheet of paper.

ESC/P

9-Pin ESC/P

Continuous paper	If an ESC J or LF command would move the print position below the bottom-margin position, the printer moves the print position to the top-of-form position on the following page.
Single-sheet paper	
<i>Loaded by cut-sheet feeder</i>	If an ESC J or LF command would move the print position below the end of the printable area, the printer ejects the paper.
<i>Loaded by hand</i>	If an ESC J or LF command would move the print position below the end of the printable area, the printer feeds the paper until the end of the page. After the next sheet is loaded, the printer feeds the paper the remaining distance specified in the ESC J or LF command.

Send Print Data

ESC/P 2

ESC/P

9-Pin ESC/P

Once you have set the page format, defined the starting characters, and set the initial print position, you can begin sending print data.

The following rules allow the printer to process data most efficiently.

- Send data from left to right on a line.
- End each line of data with a CR and LF command.
- Send lines from the top to the bottom of the page.
- Complete each page with a FF command. Also send a FF command at the end of each print job.

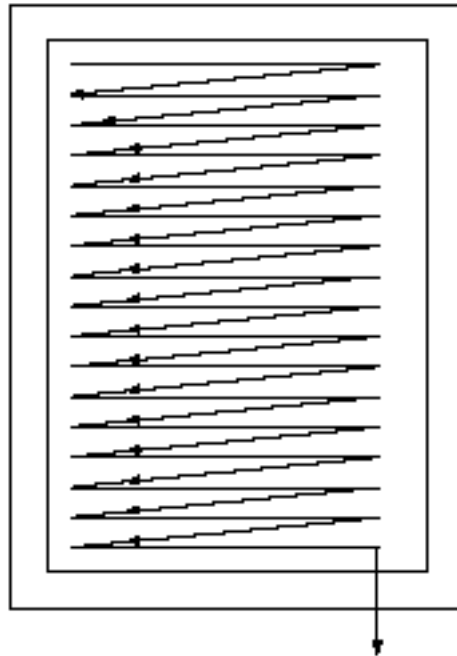

Note:

The exception to this data order is when you combine bit-image graphics with text printing. See “Mixing text and bit-image graphics” for details.

To vary printed characters, you can change font attributes and enhancements at any time. See the following sections for information on preparing and sending graphics data.

Note:

For detailed information on programming for EPSON's Stylus COLOR and other high-resolution color printers, see "Extended ESC/P 2 Programming Guide" at the end of this chapter.

To eliminate potential command conflicts during raster graphics printing, EPSON provides a special graphics mode. In this mode, some commands are not available. See "Graphics mode" for details.

Bit-image graphics

ESC/P 2

ESC/P

9-Pin ESC/P

Bit-image graphics is available on all printers. Data handling varies, however, depending on the number of pins in the print head.

The steps for printing bit-image graphics are as follows:

1. Determine vertical and horizontal dot density.
2. Prepare and organize bit-image data.
3. If you plan to send more than one line of graphics, set the line spacing to match the height of the print head.
4. Set the vertical and horizontal print position to the top left corner of the graphics line.
5. Send one line of bit-image data to the computer.
6. Complete the line with a CR and LF command.
7. Repeat steps 5 and 6 until the full graphics design is printed.

Determining vertical and horizontal dot density

ESC/P 2

ESC/P

9-Pin ESC/P

The ESC * command is used to print bit-image graphics.

The format of this command is as follows:

ESC * m n_L n_H d₁ d₂ . . . d_k

m

Specifies the dot density and printing speed. The dot density can be specified from 60 × 60 dpi (dots per inch) to up to 360 × 360 dpi, depending on the number of pins in the print head. The printing speed depends on the printing of adjacent horizontal dots; by not allowing the printing of adjacent dots, you increase the printing speed.

n_L, n_H

Specifies the number of dot columns to follow, determined by the following equation:

$$(\text{number of dot columns}) = ((n_H \times 256) + n_L)$$

$$n_H = \text{INT} \frac{(\text{number of dot columns})}{256}$$

$$n_L = \text{MOD} \frac{(\text{number of dot columns})}{256}$$

The number of bytes required for each dot column shown below.

$d_1 \dots d_k$

Data bytes

You must specify the vertical and horizontal dot density of graphics when sending the ESC * command. The dot densities available are shown in the table below.

Dot density

Parameter m in ESC * command	Horizontal density	Vertical density			Adjacent dot printing	Dots per column	Bytes per column
		9 pin	24 pin	48 pin			
0	60	72	60	60	Yes	8	1
1	120	72	60	60	Yes	8	1
2	120	72	60	60	No	8	1
3	240	72	60	60	No	8	1
4	80	72	60	60	Yes	8	1
5	72	72	N/A	N/A	Yes	8	1
6	90	72	60	60	Yes	8	1
7	144	72	N/A	N/A	Yes	8	1
32	60	N/A	180	180	Yes	24	3
33	120	N/A	180	180	Yes	24	3
38	90	N/A	180	180	Yes	24	3
39	180	N/A	180	180	Yes	24	3
40	360	N/A	180	180	No	24	3
64	60	N/A	N/A	360	Yes	48	6
65	120	N/A	N/A	360	Yes	48	6
70	90	N/A	N/A	360	Yes	48	6
71	180	N/A	N/A	360	Yes	48	6
72	360	N/A	N/A	360	No	48	6
73	360	N/A	N/A	360	Yes	48	6

Note:

If the mode you select does not allow adjacent dot printing, the printer ignores the second of two consecutive horizontal dots as shown below:

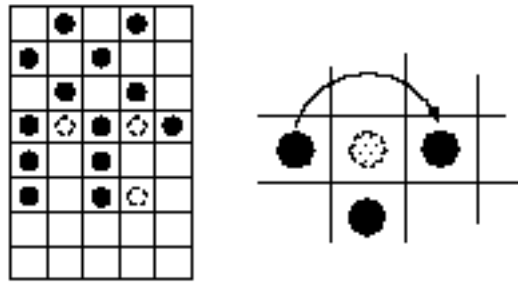

Preparing bit-image data

Once you have determined the dot density, create a grid for plotting your design. If the horizontal density is not the same as the vertical density, make a grid that reflects this.

See the sample grids below.

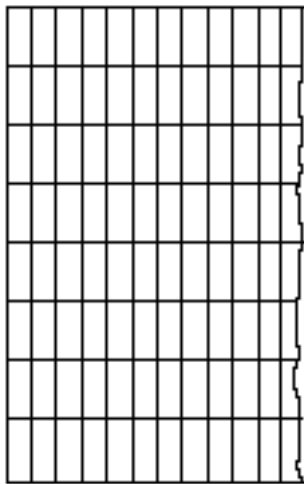

8-dot columns

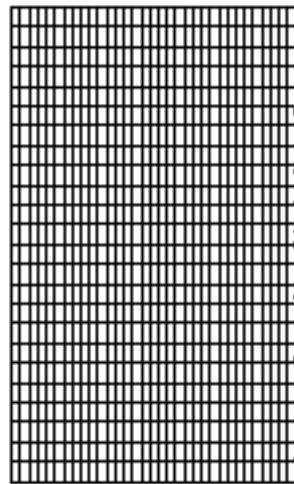

24-dot columns

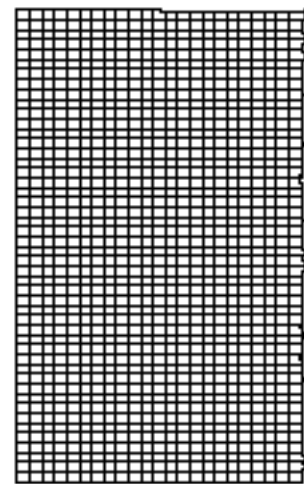

48-dot columns

Divide the grid into columns of 1, 3, or 6 bytes, depending on the m parameter of the dot density you select. The illustrations in the next two sections depict the following examples:

m = 0

60 × 60 dpi (60 × 72 dpi for 9-pin printers)

m = 39

180 × 180 dpi

m = 72

360 × 360 dpi

After plotting the design, divide the grid into groups one dot wide and eight dots high.

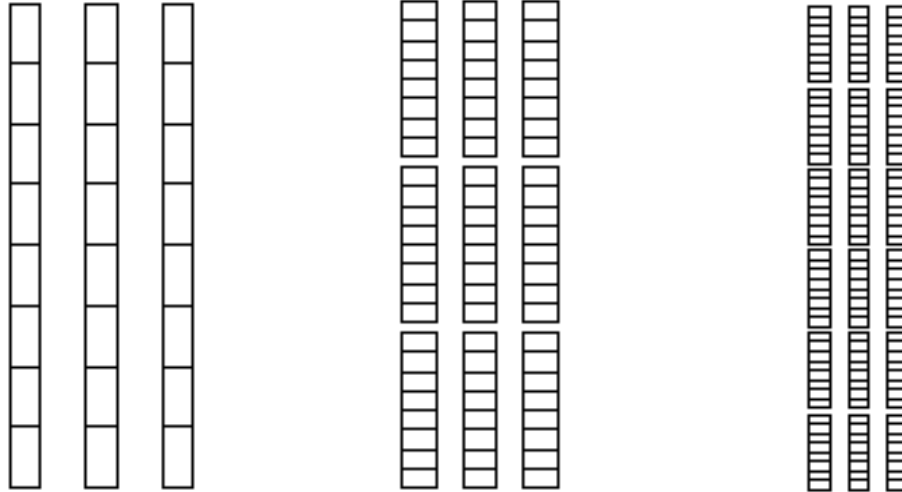

The dots in each group have a value, as shown in the following diagram. The sum of each group is sent as a byte of data to the printer. Calculate the value for each byte as shown.

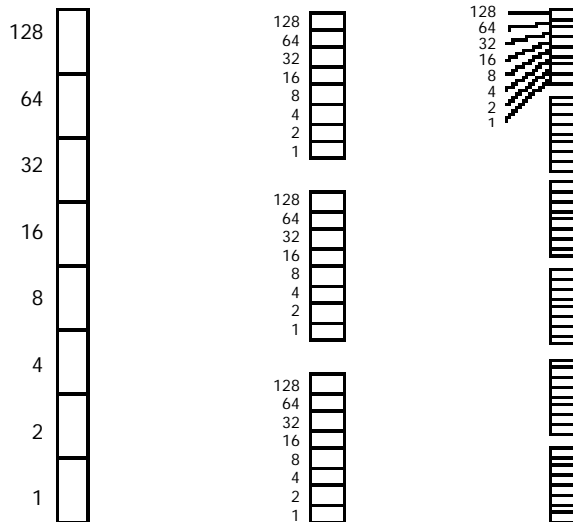

Sending bit-image data to the printer

The order for sending data depends on the mode selected with the *m* parameter. The table at the beginning of this section lists the number of bytes of data required for each column.

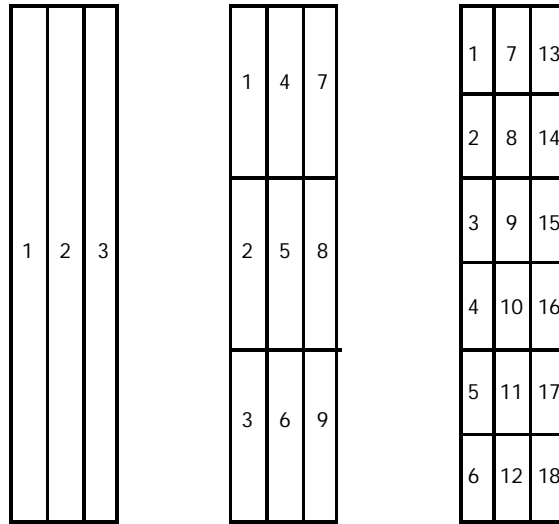

Count the number of resulting columns in each line. The n_L and n_H parameters tell the printer how many columns to expect. Calculate n_L and n_H as follows:

$$n_H = \text{INT} \frac{(\text{number of dot columns})}{256}$$

$$n_L = \text{MOD} \frac{(\text{number of dot columns})}{256}$$

If you are going to send more than one line of graphics, send the following commands to set the line spacing:

24/48-pin printers	ESC + 48	48/360-inch line spacing
9-pin printers	ESC 3 24	24/216-inch line spacing

This matches the line spacing to the height of the print head. After this, sending the CR and LF commands moves the vertical print position so the next line of graphics begins right where the previous line ended, with no space between.

Now send the data for the first line to the printer as follows:

ESC * 0 n_L n_H d_1 d_2 . . . d_k

ESC * 39 n_L n_H d_1 d_2 . . . d_k

ESC * 72 n_L n_H d_1 d_2 . . . d_k

At the end of the line, send the CR and LF commands. Move the horizontal print position as necessary. Then send the ESC * command for the next line of graphics.

Note:

- Since the vertical dot density during 8-dot mode is different for 9 and 24/48-pin printers, printed graphics will differ slightly (graphics on 9-pin printers will appear slightly compressed vertically).
- You must send the ESC * command for each line of graphics.

Mixing text and bit-image graphics with ESC/P 2 printers

ESC/P 2

ESC/P 2 printers can process more than one line of data at a time; this allows for advanced features such as scalable fonts and raster graphics.

More memory has been provided for processing data than previous ESC/P versions. By processing data within this memory before printing, mixing bit-image graphics and text of all point sizes is possible.

To provide the most efficient processing of data in the memory available, ESC/P 2 has the following rules:

- You cannot move the vertical print position more than 179/360 inch (one dot less than 1/2 inch) in the negative direction.
- You cannot move the vertical print position in the negative direction if you have just sent graphics data, or if the print position would move above previously printed graphics data.

Because of these rules, you should process data with text data always leading graphics data by 1/2 inch.

Follow the steps below for this process.

1. Use the ESC + 48 command to set the line spacing to match the print head height.
2. Send the first 1/2 inch of text data to the printer. You can print any combination of fonts (large and small point sizes, etc.) on multiple lines; however, make sure the baseline of all characters is located within this 1/2-inch.
3. Use the ESC (V or ESC (v commands to move the print position to the top of the 1/2-inch zone.
4. Use the ESC * command to send one line of graphics data (see the previous section). End the graphics line with the CR and LF commands. Note that the height of one line of graphics is equal to the height of the print head (48/360-inch).

5. Move the vertical print position to the bottom of the 1/2-inch zone.
6. Send all text data that has its baseline located in the next 48/360-inch band.
7. Move the vertical print position to 1/360 inch below the bottom of the previous line of graphics.
8. Continue sending alternating 48/360-inch bands of text, then data, with the text leading the graphics by 1/2 inch (as described in steps 4 to 7).
9. When you reach the end of the text data, or the page's bottom margin, send all the remaining lines of graphics data.

This order allows the printer to store text data in its memory first. Then, when you send the graphics data, the printer prints out the combined data.

Note:

If you don't follow this order, the tops of some characters may be cut off. This can occur when part of a character overlaps previously printed graphics.

Graphics mode

ESC/P 2

ESC/P 2 printers feature a method of printing graphics, called raster graphics. To prevent conflicts with existing commands, EPSON uses a special graphics mode. You can send raster graphics commands only when in this mode.

Raster graphics gives the programmer a simple, consistent method of printing bit-map images. Raster graphics provides the following advantages:

- Prints images in a consistent manner, regardless of the print head configuration (24 or 48 pins)
- Eliminates necessity for interleaving lines to achieve maximum dot density
- Eliminates complicated calculations for handling data in specific band heights
- Provides for data compression; two bytes of data (a counter byte and a data byte) can specify up to 1,016 dots. Also, repetitive and nonrepetitive data can be sent in the same data string.

Standard raster graphics commands are available to all ESC P/2 printers. An additional set of raster graphics commands, known as extended raster graphics, was developed for EPSON's line of high-resolution color ink jet printers. This new set of commands provides one additional compressed raster graphics mode, which can be accessed by sending the ESC . 2 command.

Entering and exiting graphics mode

ESC/P 2

Graphics mode is entered by sending the ESC (G command. The format of the command is as follows:

ESC (G 1 0 1

You can only enter graphics mode with this command. Use the ESC @ (initialize printer) command to exit graphics mode.

Commands available in graphics mode

Only the following commands are available in standard raster graphics mode:

LF	Line feed
CR	Carriage return
ESC .	Print raster graphics
ESC . 1	Enter RLE compressed mode
ESC . 2	Enter TIFF compressed mode (Stylus COLOR only)
ESC (c	Set page format
ESC (V	Set absolute vertical position
ESC \$	Set absolute horizontal position
ESC r	Select printing color
ESC +	Set n/360-inch line spacing
FF	Form feed
ESC EM	Control paper loading/ejecting
ESC @	Initialize printer (exit graphics mode)
ESC (C	Set page length in defined unit
ESC (v	Set relative vertical position
ESC \	Set relative horizontal position
ESC U	Turn unidirectional on/off
ESC (U	Set unit
ESC (i	MicroWeave (Stylus COLOR only)

The following subset of binary mode commands is available in extended raster graphics mode, entered by sending the ESC . 2 command. All other commands are ignored.

<XFER>	Transfer raster graphics data
<MOVX>	Set relative horizontal position
<MOVY>	Set relative vertical position
<COLR>	Select printing color
<CR>	Carriage return to left-most print position
<EXIT>	Exit TIFF compressed mode
<MOVXBYTE>	Set <MOVX> unit to 8 dots
<MOVXDOT>	Set <MOVX> unit to 1 dot

Other commands not listed above are ignored. Also, text cannot be sent during graphics mode.

Standard raster graphics

ESC/P 2

Raster graphics allows the programmer to send image data in a format similar to that used by televisions, VDT monitors, and laser printers.

Follow these steps to prepare and send raster graphics:

1. Determine the dot density (resolution) of your image.

2. Use the ESC (U command to set the unit to match the vertical dot density selected.
3. Divide your image into bands. These bands should be 1, 8, or 24-dots high. Parameter m in the ESC . command should be set to this value.
4. Use the ESC + command to set line spacing to match the height of the vertical band. If you select 360-dpi dot density, the parameter for the ESC + command is the same as parameter m in the ESC . command. If you select 180, the ESC + parameter equals $m \times 2$.
5. Set the vertical and horizontal positions to begin the first graphics band.
6. Use the ESC . command to send a graphics band m dots high.
7. Send the CR and LF commands at the end of each block; then move the horizontal position to the beginning of the next graphics band.
8. Repeat steps 6 and 7 until all graphics data is sent for the page.
9. Send a FF command at the end of the page.
10. Repeat steps 6 to 9 for all pages in the print job.

The format of the ESC . (standard raster graphics) command is as follows:

ESC . c v h m n_L n_H d₁ d₂ . . . d_k

c = 0 Selects full graphics mode; all data bytes are treated as print data

1 Selects run length encoded compressed mode; data treated as follows: counter byte, data, counter byte, data

v Specifies vertical dot density (independent of number of pins in head)

$$(\text{vertical dot density}) = \frac{3600}{v} \text{ dpi}$$

h Specifies horizontal dot density (independent of number of pins in head)

$$(\text{horizontal dot density}) = \frac{3600}{h} \text{ dpi}$$

m Specifies vertical dot count (1, 8, or 24)

n_L, n_H Specifies horizontal dot count

$$(\text{horizontal dot count}) = ((n_H \times 256) + n_L)$$

d₁ . . . d_k Data or counter/data combination

The vertical and horizontal dot densities that can be selected are as follows:

h	v	horizontal density	vertical density
20	20	180	180
10	20	360	180
10	10	360	360

Once you have decided the dot density, use the ESC (U to set the unit to match the vertical dot density.

ESC (U 1 0 10 Selects 1/360-inch unit
 ESC (U 1 0 20 Selects 1/180-inch unit

Next, create a grid for plotting your design. If the horizontal density is not the same as the vertical density, make a grid that reflects this.

See the sample grid below.

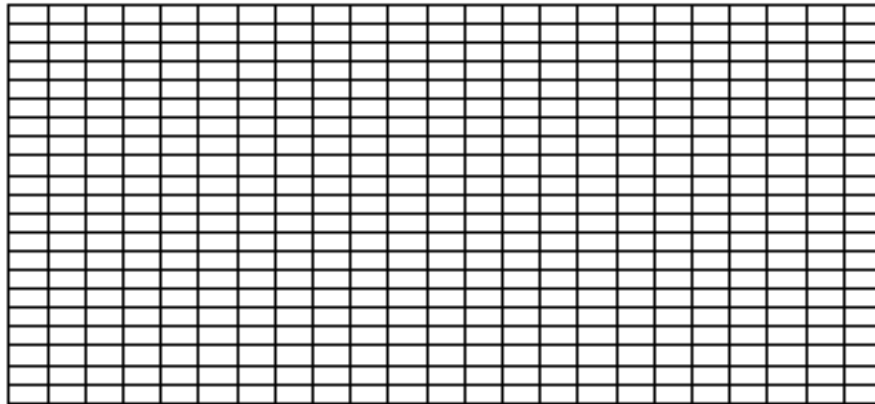

After plotting the design, divide the grid into groups one dot high and eight dots wide.



The dots in each group have a value, as shown in the following diagram. Calculate the value for each group as shown.

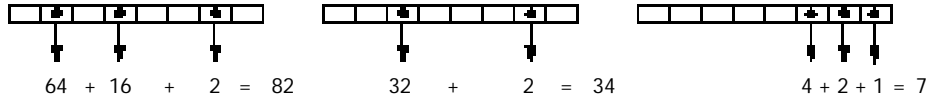

Divide your image into bands 1, 8, or 24-dots high. The number of vertical dots is called the band height. This is the value you should use for parameter *m* in the ESC . command.

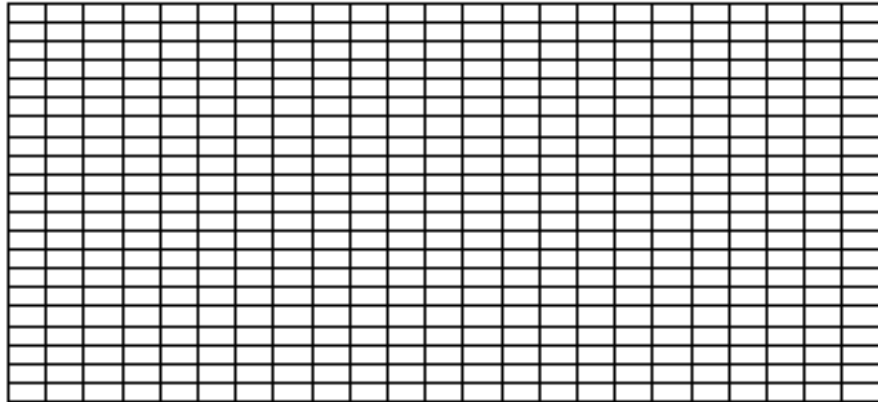
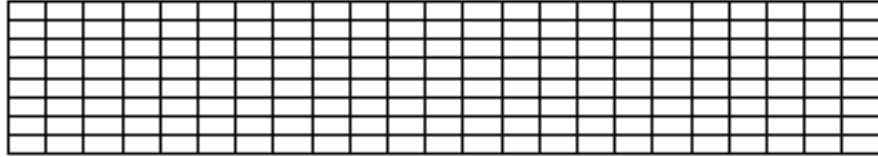

The band height affects the following:

- The taller the band height, the more memory you must prepare in your program to accommodate graphics data.
- The band height determines the number of times you must send the ESC . command. You must resend the ESC . command for each band of graphics you print. The taller the band height, the less number of ESC . commands you need to send.

The following table gives you an idea of how much memory is required for band heights at certain standard widths.

Band width	Bytes required for band heights at 180-dpi horizontal dot density			Bytes required for band heights at 360-dpi horizontal dot density		
	1-dot band height	8-dot band height	24-dot band height	1-dot band height	8-dot band height	24-dot band height
8 inches	180	1,440	4,320	360	2,880	8,640
11 inches	248	1,984	5,952	495	3,960	11,880
14 inches	315	2,520	7,560	630	5,040	15,120

Use the ESC + command to set line spacing to match the band height. The following table shows the command format for each band height.

ESC + command setting	Vertical dot density (dpi)	Band height (dots)	Band height (inches)	Parameter m in ESC . command
ESC + 1	360	1	1/360	1
ESC + 2	180	1	2/360	1
ESC + 8	360	8	8/360	8
ESC + 16	180	8	16/360	8
ESC + 24	360	24	24/360	24
ESC + 48	180	24	48/360	24

Before sending data, you must also determine the width of your graphics image. The width is also specified in number of dots. Of course, data must be sent in bytes; all data beyond the dot width specified is ignored.

The following illustration shows the dot width and the ignored data.

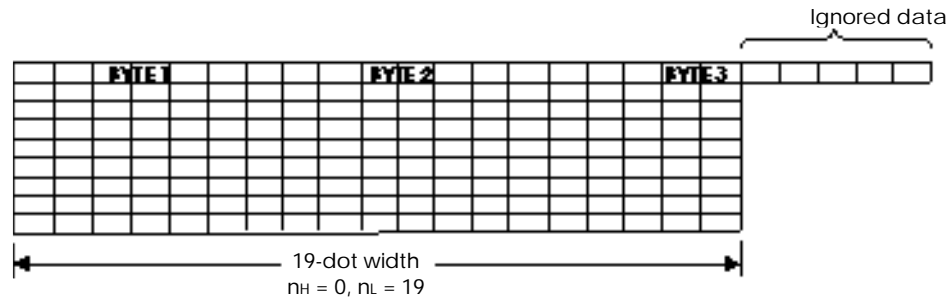

Determine the dot-width parameters for the ESC . command as follows:

$$n_H = \text{INT} \frac{(\text{dot width})}{256}$$

$$n_L = \text{MOD} \frac{(\text{dot width})}{256}$$

Use a combination of the ESC (V, ESC (v, ESC \$, or ESC \ commands to set the beginning position of the first graphics band. The print position corresponds to the position of the first printable dot in your image.

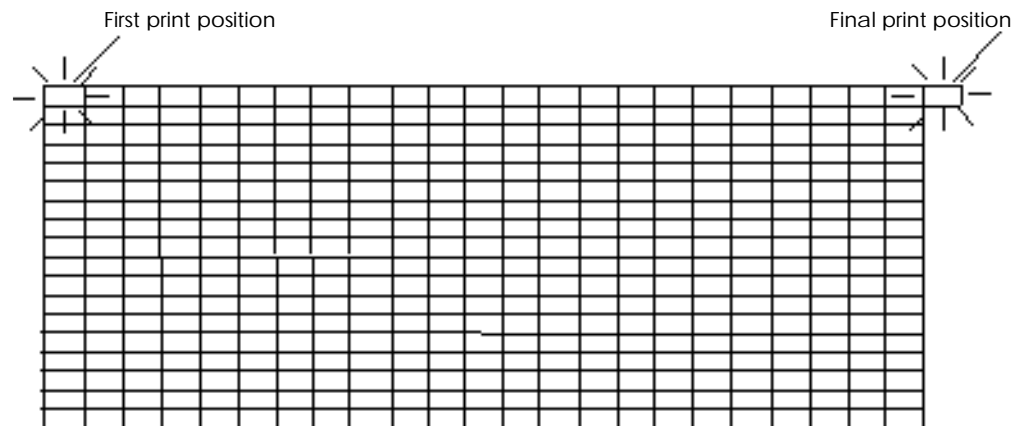

You are now ready to send data with the ESC . command.

The method of sending data in standard raster graphics mode depends on whether you select full graphics (ESC.0) or compressed mode (ESC . 1). For a discussion of extended raster graphics compressed modes, see “Extended raster graphics (ESC . 2).”

Full graphics mode (ESC . 0)

ESC/P 2

If you set the ESC . command’s parameter *c* to 0, you select full graphics mode. During full graphics mode, all data received is treated as print data.

Note:

Full graphics mode requires more data to be sent. Use compressed raster graphics mode whenever possible.

During full graphics mode, simply divide the image grid into bytes and send the bytes one after another, in the following order.

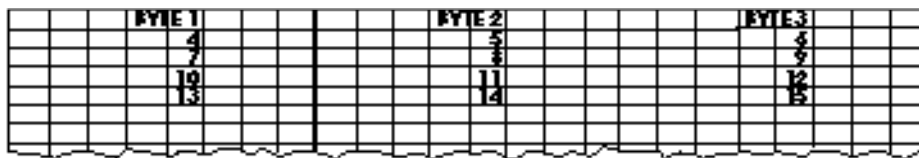

After sending the data for the graphics band, send a CR and LF command.

ESC/P 2

The method of sending data in standard raster graphics compressed mode is slightly more complicated. However, the amount of data necessary to print graphics may be greatly reduced. When possible, you should use one of the available compressed modes. For information on extended raster graphics compressed modes, see “Extended raster graphics (ESC . 2).”

Data is organized as counter bytes followed by data bytes. Two types of counters can be used: repeat counters and data-length counters.

Repeat counters specify the number of times (minus 1) to repeat the following single byte of data.

Data-length counters specify the number of bytes (minus 1) of print data following the counter. This data is printed only once.

If the counter is positive, it is treated as a data-length counter.

$$0 \leq (\text{data-length counter}) \leq 127$$

The data-length counter is calculated as follows:

$$(\text{data-length counter}) = (\text{number of data bytes to follow}) - 1$$

If the counter is negative (as determined by two’s complement), it is treated as a repeat counter.

$$-1 \leq (\text{repeat counter}) \leq -127$$

The repeat counter is calculated as follows:

$$(\text{repeat counter}) = 256 - (\text{number of times to repeat data}) + 1$$

During compressed mode, the first byte of data must be a counter. After receiving a counter, the printer handles data as follows:

If a repeat counter is received, the printer repeats the following byte of data the specified number of times. The byte following the data byte is treated as a counter.

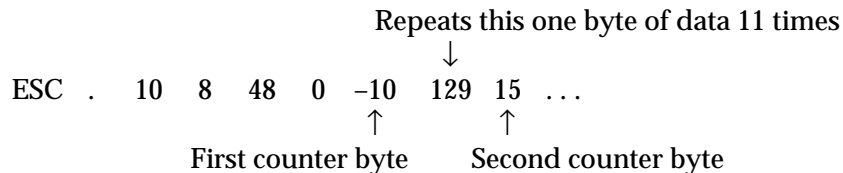

Extended raster graphics (ESC . 2)

ESC/P 2

Extended raster graphics provides one data compression mode: TIFF (ESC . 2). For more information on programming with this command, see “Extended ESC/P 2 Programming Guide” later in this section.

A brief explanation of each mode is given below.

TIFF compressed mode (ESC . 2)

Uses the TIFF compression format. Image data for each color is written to the band buffer (of the current line) and has no effect on the next line. Image data must be sent for each line. The compression method is the same as that used in the RLE compressed mode (ESC . 1), which means that image data is sent in the “counter + image data” format. Although both compression methods use the same amount of image data, the amount of code data required by each method varies markedly. The TIFF mode uses a subset of binary commands that require much less data than the corresponding ESC commands used in the RLE mode. For example, the print position, color selection, and other operation codes can be specified with only 1 to 3 bytes in the TIFF mode, thereby reducing the overall amount of data sent to the printer. The TIFF mode provides a good balance between data handling speed and the amount of data compression, making it ideal for printing small graphics files.

An example of the data compression methods used in extended raster graphics mode is shown below. For more information, see the explanation of each command in Individual Command Descriptions.

Sample graphics image (3 lines, 3 × 24 dots)

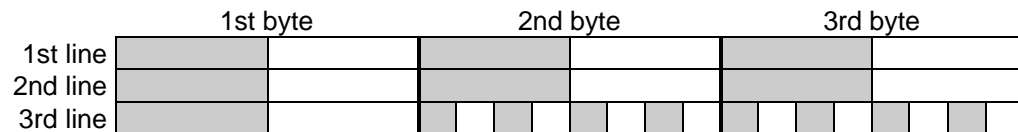

Sample graphics image expressed as byte data

	1st byte	2nd byte	3rd byte
1st line	F0H	F0H	F0H
2nd line	F0H	F0H	F0H
3rd line	F0H	AAH	AAH

TIFF compressed mode

After sending ESC . 2 v h 1 0 0 (8 bytes) once to enter TIFF compressed mode, following data is sent in the “binary code data + image data” format, and can be used to print several lines. In this mode, all image data must be sent again even if the following line is identical to the previous one. For example, to print the first and second lines in the above example, 4 bytes (3 × F0H (twice)) of image data are needed. The total amount of data used to send the graphics image sample shown above is as follows:

2 bytes (image data of 1st line) + 9 bytes (code data of 1st line) + 2 bytes (image data of 2nd line) + 2 bytes (code data of 2nd line) + 4 bytes (image data of 3rd line) + 2 bytes (code data of 3rd line) = 21 bytes

Printing Bar Codes

ESC/P 2

ESC/P

9-Pin ESC/P

Barcode print is available on DLQ-3000('96-), LQ-670, LQ-2070, LQ-2170, FX-2170 and later impact dot matrix models.

The ESC (B command is used to print barcodes. The format of this command is as follows:

ESC (B n_L n_H k m s v_1 v_2 c BarCodeData

n_L n_H Specify the number of data bytes to follow, determined by the following equation:

$$\begin{aligned} \text{(number of data bytes)} &= 6 \text{ bytes} + \text{BarCodeData bytes} = ((n_H \times 256) + n_L) \\ &\text{(where 6 bytes are } k, m, s, v_1, v_2, \text{ and } c) \end{aligned}$$

$$n_H = \text{INT} \frac{\text{(number of data bytes)}}{256}$$

$$n_L = \text{MOD} \frac{\text{(number of data bytes)}}{256}$$

The parameter **k** specifies the barcode type.

k (Hex)	Bar code type
00	EAN-13
01	EAN-8
02	Interleaved 2 of 5
03	UPC-A
04	UPC-E
05	Code 39
06	Code 128
07	POSTNET

The parameter **m** specifies the module width.

m	24-pin printer (unit 1/180 inch)	9-pin printer (unit 1/120 inch)
02 (default)	2 dots	2 dots
03	3 dots	3 dots
04	4 dots	4 dots
05	5 dots	5 dots

The parameter **s** specifies the space adjustment value.

24-pin printer	$-3 \leq s \leq 3$ (unit 1/360 inch)
9-pin printer	$-3 \leq s \leq 3$ (unit 1/240 inch)

The parameter **v₁** and **v₂** specifies the bar length.

24-pin printer	bar length = $v_1 + v_2 \times 256$ (unit 1/180 inch)
9-pin printer	bar length = $v_1 + v_2 \times 256$ (unit 1/72 inch)

The limitation of bar length:

$$45/180 \text{ inch} \leq \text{bar length} \leq 22 \text{ inch} \quad : \text{24-pin printer}$$

$$18/72 \text{ inch} \leq \text{bar length} \leq 22 \text{ inch} \quad : \text{9-pin printer}$$

The v_1 and v_2 values are ignored when POSTNET is selected.

Long bar length of POSTNET is always 0.125 inch.

Short bar length of POSTNET is always 0.050 inch.

The parameter **c** specifies the control flag.

c	Control flag
bit 0	Check digit 0: If check digit is to be printed, the host generates it and sends it to the printer 1: Printer generates and prints the check digit
Bit 1	Human readable character 0: Prints 1: Does not print
Bit 2	Position of flag character (for EAN-13 and UPC-A only) 0: Center 1: Under
bit 3	(reserved)
bit 4	(reserved)
bit 5	(reserved)
bit 6	(reserved)
bit 7	(reserved)

Barcode Data Corresponds to the bar code symbology.
The data number of each bar code type is constant.
The bar code is not printed if the number of bar code characters are incorrect.

Bar code type	Actual number of Barcode Data (HEX)	
	control flag c bit 0 = 0	control flag c bit 0 = 1
EAN-13	0D	0C
EAN-8	08	07
Interleaved 2 of 5	02 to FF	02 to FF
UPC-A	0C	0B
UPC-E	0C or 8	0B or 7
Code 39	01 to FF	01 to FF
Code 128	02 to FF	02 to FF
POSTNET	06 or 0A or 0C	05 or 09 or 0B

The valid data of each bar code type are as follows.
If invalid data is included in the Barcode Data string, the bar code is not printed.

Bar code type	Valid range of BarCodeData
EAN-13	0-9 (30H-39H)
EAN-8	0-9 (30H-39H)
Interleaved 2 of 5	0-9 (30H-39H)
UPC-A	0-9 (30H-39H)
UPC-E	0-9 (30H-39H)
Code 39	0-9 (30H-39H), (41H-5AH) (20H, 24H, 25H, 2BH, 2DH, 2EH, 2FH)
Code 128	See the code sets A, B, and C on the following pages.
POSTNET	0-9 (30H-39H)

Data Character Set A:

Character	Hex Code	Character	Hex Code	Character	Hex Code	Character	Hex Code
NUL	x00	Space	x20	'@'	x40	FNC 3	x60
OH	x01	'!	x21	'A'	x41	FNC 2	x61
STX	x02	""	x22	'B'	x42	Shift	x62
EXT	x03	'#'	x23	'C'	x43	Code C	x63
EOT	x04	'\$'	x24	'D'	x44	Code B	x64
ENO	x05	'%'	x25	'E'	x45	FNC 4	x65
ACK	x06	'&'	x26	'F'	x46	FNC 1	x66
BEL	x07	""	x27	'G'	x47	—	—
BS	x08	'('	x28	'H'	x48	—	—
HT	x09	')'	x29	'I'	x49	—	—
LF	x0A	**	x2A	'J'	x4A	—	—
VT	x0B	'+'	x2B	'K'	x4B	—	—
FF	x0C	','	x2C	'L'	x4C	—	—
CR	x0D	','	x2D	'M'	x4D	—	—
SO	x0E	','	x2E	'N'	x4E	—	—
SI	x0F	','	x2F	'O'	x4F	—	—
DLE	x10	'0'	x30	'P'	x50	—	—
DC1	x11	'1'	x31	'Q'	x51	—	—
DC2	x12	'2'	x32	'R'	x52	—	—
DC3	x13	'3'	x33	'S'	x53	—	—
DC4	x14	'4'	x34	'T'	x54	—	—
NAK	x15	'5'	x35	'U'	x55	—	—
SYN	x16	'6'	x36	'V'	x56	—	—
ETB	x17	'7'	x37	'W'	x57	—	—
CAN	x18	'8'	x38	'X'	x58	—	—
EM	x19	'9'	x39	'Y'	x59	—	—
SUB	x1A	':'	x3A	'Z'	x5A	—	—
ESC	x1B	':'	x3B	'['	x5B	—	—
FS	x1C	'<'	x3C	'\'	x5C	—	—
GS	x1D	'='	x3D	']'	x5D	—	—
RS	x1E	'>'	x3E	^	x5E	—	—
US	x1F	'?'	x3F	'_'	x5F	—	—

Data Character Set B:

Character	Hex Code	Character	Hex Code	Character	Hex Code	Character	Hex Code
		Space	x20	'@'	x40		x60
		'!'	x21	'A'	x41	'a'	x61
		"	x22	'B'	x42	'b'	x62
		'#'	x23	'C'	x43	'c'	x63
		'\$'	x24	'D'	x44	'd'	x64
		'%'	x25	'E'	x45	'e'	x65
		'&'	x26	'F'	x46	'f'	x66
		"	x27	'G'	x47	'g'	x67
		'('	x28	'H'	x48	'h'	x68
		')'	x29	'I'	x49	'i'	x69
		**	x2A	'J'	x4A	'j'	x6A
		'+'	x2B	'K'	x4B	'k'	x6B
		','	x2C	'L'	x4C	'l'	x6C
		','	x2D	'M'	x4D	'm'	x6D
		','	x2E	'N'	x4E	'n'	x6E
		','	x2F	'O'	x4F	'o'	x6F
		'0'	x30	'P'	x50	'p'	x70
		'1'	x31	'Q'	x51	'q'	x71
		'2'	x32	'R'	x52	'r'	x72
		'3'	x33	'S'	x53	's'	x73
		'4'	x34	'T'	x54	't'	x74
		'5'	x35	'U'	x55	'u'	x75
		'6'	x36	'V'	x56	'v'	x76
		'7'	x37	'W'	x57	'w'	x77
		'8'	x38	'X'	x58	'x'	x78
FNC 3	x19	'9'	x39	'Y'	x59	'y'	x79
FNC 2	x1A	':'	x3A	'Z'	x5A	'z'	x7A
Shift	x1B	':'	x3B	'['	x5B	'{'	x7B
Code C	x1C	'<'	x3C	'\'	x5C	'/'	x7C
FNC 4	x1D	'='	x3D	']'	x5D	'}'	x7D
Code A	x1E	'>'	x3E	'^'	x5E	'~'	x7E
FNC 1	x1F	'?'	x3F	'_'	x5F	DEL	x7F

Data Character Set C:

Character	Hex Code	Character	Hex Code	Character	Hex Code	Character	Hex Code
'00'	x3030	'32'	x3332	'64'	x3634	'96'	x3936
'01'	x3031	'33'	x3333	'65'	x3635	'97'	x3937
'02'	x3032	'34'	x3334	'66'	x3636	'98'	x3938
'03'	x3033	'35'	x3335	'67'	x3637	'99'	x3939
'04'	x3034	'36'	x3336	'68'	x3638	Code B	x3A
'05'	x3035	'37'	x3337	'69'	x3639	Code A	x3B
'06'	x3036	'38'	x3338	'70'	x3730	FNC 1	x3C
'07'	x3037	'39'	x3339	'71'	x3731	—	—
'08'	x3038	'40'	x3430	'72'	x3732	—	—
'09'	x3039	'41'	x3431	'73'	x3733	—	—
'10'	x3130	'42'	x3432	'74'	x3734	—	—
'11'	x3131	'43'	x3433	'75'	x3735	—	—
'12'	x3132	'44'	x3434	'76'	x3736	—	—
'13'	x3133	'45'	x3435	'77'	x3737	—	—
'14'	x3134	'46'	x3436	'78'	x3738	—	—
'15'	x3135	'47'	x3437	'79'	x3739	—	—
'16'	x3136	'48'	x3438	'80'	x3830	—	—
'17'	x3137	'49'	x3439	'81'	x3831	—	—
'18'	x3138	'50'	x3530	'82'	x3832	—	—
'19'	x3139	'51'	x3531	'83'	x3833	—	—
'20'	x3230	'52'	x3532	'84'	x3834	—	—
'21'	x3231	'53'	x3533	'85'	x3835	—	—
'22'	x3232	'54'	x3534	'86'	x3836	—	—
'23'	x3233	'55'	x3535	'87'	x3837	—	—
'24'	x3234	'56'	x3536	'88'	x3838	—	—
'25'	x3235	'57'	x3537	'89'	x3839	—	—
'26'	x3236	'58'	x3538	'90'	x3930	—	—
'27'	x3237	'59'	x3539	'91'	x3931	—	—
'28'	x3238	'60'	x3630	'92'	x3932	—	—
'29'	x3239	'61'	x3631	'93'	x3933	—	—
'30'	x3330	'62'	x3632	'94'	x3934	—	—
'31'	x3331	'63'	x3633	'95'	x3935	—	—

Print position:

A bar code is placed the left upper end of a bar code to the current vertical and horizontal print position. Also printing position after the printing of a bar code returns to the print position before bar code printing.

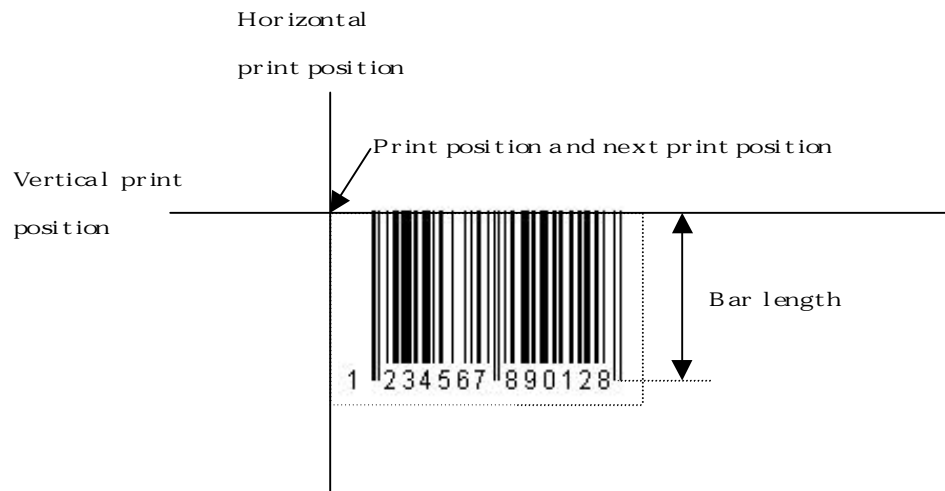

Notes:

- (1) Bar code printing is always performed uni-directionally.
- (2) The bar code is not printed when part of the bar code is past the right margin.
- (3) Start/stop characters(*) of Code39 are generated automatically by the printer, and added to human readable characters.
- (4) A kind of Code 128 character sets (A, B or C) is identified by the first data of Code 128. The first data must be a hexadecimal 41 (A), 42 (B) and 43 (C).
- (5) When Code 128 Character Set C and Interleaved 2 of 5 is selected and the number of Barcode data are ODD, "0" is added to the data string.

Examples:

example 1: EAN-13, CD: Host, HRI: print, Flag Char.: center

(CD: Check digit, HRI: Human Readable character)

1B 28 42 13 00 ; Barcode command and data length
00 ; Barcode type **k** = EAN-13
02 ; Module width **m** = 2 dots / 180 inch
00 ; Space adjustment value **s** = +0 dots / 360 inch
7D 00 ; Bar length **v1**, **v2** = 125 / 180 inch
00 ; Control flags **c**
30 31 32 33 34 35 36 ; Barcode Data
37 38 39 30 31 32 ;



example 2: EAN-13, CD: Printer, HRI: print, Flag Char.: under

1B 28 42 12 00 ; Barcode command and data length
00 ; Barcode type **k** = EAN-13
02 ; Module width **m** = 2 dots / 180 inch
00 ; Space adjustment value **s** = +0 dots / 360 inch
7D 00 ; Bar length **v1**, **v2** = 125 / 180 inch
05 ; Control flags **c**
31 32 33 34 35 36 ; Barcode Data
37 38 39 30 31 32



example 3: EAN-13, CD: Printer, HRI: none, Flag Char.: under

1B 28 42 12 00 ; Barcode command and data length
00 ; Barcode type **k** = EAN-13
02 ; Module width **m** = 2 dots / 180 inch
00 ; Space adjustment value **s** = +0 dots / 360 inch
7D 00 ; Bar length **v1**, **v2** = 125 / 180 inch
03 ; Control flags **c**
31 32 33 34 35 36 ; Barcode Data
37 38 39 30 31 32



example 4: EAN-8, CD: Host, HRI: print

1B 28 42 0E 00 ; Barcode command and data length
01 ; Barcode type **k** = EAN-8
02 ; Module width **m** = 2 dots / 180 inch
00 ; Space adjustment value **s** = +0 dots / 360 inch
7D 00 ; Bar length **v1**, **v2** = 125 / 180 inch
00 ; Control flags **c**
30 31 32 33 34 35 36 35 ; Barcode Data



example 5: EAN-8, CD: Printer, HRI: none

1B 28 42 0D 00 ; Barcode command and data length
01 ; Barcode type **k** = EAN-8
02 ; Module width **m** = 2 dots / 180 inch
00 ; Space adjustment value **s** = +0 dots / 360 inch
7D 00 ; Bar length **v1**, **v2** = 125 / 180 inch
03 ; Control flags **c**
30 31 32 33 34 35 36 ; Barcode Data

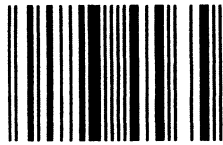

example 6: Interleaved 2 of 5, CD: Host, HRI: print

1B 28 42 1A 00 ; Barcode command and data length
02 ; Barcode type **k** = Interleaved 2 of 5
02 ; Module width **m** = 2 dots / 180 inch
00 ; Space adjustment value **s** = +0 dots / 360 inch
7D 00 ; Bar length **v1**, **v2** = 125 / 180 inch
00 ; Control flags **c**
31 32 33 34 35 36 37 ; Barcode Data
38 39 30 31 32 33 34 ;
35 36 37 38 39 30 ;



example 7: Interleaved 2 of 5, CD: Printer, HRI: none

```
1B 28 42 19 00 ; Barcode command and data length
02 ; Barcode type k = Interleaved 2 of 5
02 ; Module width m = 2 dots / 180 inch
00 ; Space adjustment value s = +0 dots / 360 inch
7D 00 ; Bar length v1, v2 = 125 / 180 inch
03 ; Control flags c
31 32 33 34 35 36 37 ; Barcode Data
38 39 30 31 32 33 34 ;
35 36 37 38 39 ;
```

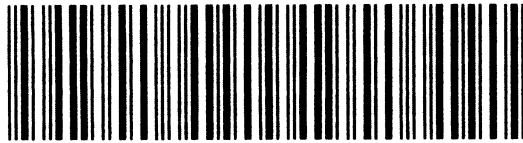

example 8: Interleaved 2 of 5, CD: Host, HRI: print

Next example is that '0' is added automatically, in the case that the data number is odd.

```
1B 28 42 19 00 ; Barcode command and data length
02 ; Barcode type k = Interleaved 2 of 5
02 ; Module width m = 2 dots / 180 inch
00 ; Space adjustment value s = +0 dots / 360 inch
7D 00 ; Bar length v1, v2 = 125 / 180 inch
00 ; Control flags c
31 32 33 34 35 36 37 ; Barcode Data
38 39 30 31 32 33 34 ;
35 36 37 38 39 ;
```

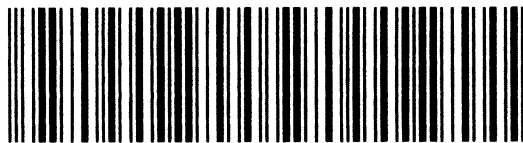

0 1 2 3 4 5 6 7 8 9 0 1 2 3 4 5 6 7 8 9

example 9: UPC-A, CD: Host, HRI: Print, Flag Char.: center

```
1B 28 42 12 00 ; Barcode command and data length
03 ; Barcode type k = UPC-A
02 ; Module width m = 2 dots / 180 inch
00 ; Space adjustment value s = +0 dots / 360 inch
7D 00 ; Bar length v1, v2 = 125 / 180 inch
00 ; Control flags c
30 31 32 33 34 35 36 ; Barcode Data
37 38 39 30 35 ;
```



0 1 2 3 4 5 6 7 8 9 0 5

example 10: UPC-A, CD: Printer, HRI: print, Flag Char.: under

```

1B 28 42 11 00      ; Barcode command and data length
03                  ; Barcode type k = UPC-A
02                  ; Module width m = 2 dots / 180 inch
00                  ; Space adjustment value s = +0 dots / 360 inch
7D 00              ; Bar length v1, v2 = 125 / 180 inch
05                  ; Control flags c
31 32 33 34 35 36  ; Barcode Data
37 38 39 30 31      ;

```



example 11: UPC-A, CD: Printer, HRI: none, Flag Char.: center

```

1B 28 42 11 00      ; Barcode command and data length
03                  ; Barcode type k = UPC-A
02                  ; Module width m = 2 dots / 180 inch
00                  ; Space adjustment value s = +0 dots / 360 inch
7D 00              ; Bar length v1, v2 = 125 / 180 inch
03                  ; Control flags c
31 32 33 34 35 36  ; Barcode Data
37 38 39 30 31      ;

```

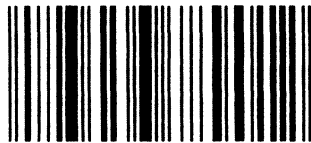

example 12: UPC-E, CD: Host, HRI: print
 Next example is that of barcode data compacted in accordance with specifications by the printer.

```

1B 28 42 12 00      ; Barcode command and data length
04                  ; Barcode type k = UPC-E
02                  ; Module width m = 2 dots / 180 inch
00                  ; Space adjustment value s = +0 dots / 360 inch
7D 00              ; Bar length v1, v2 = 125 / 180 inch
00                  ; Control flags c
30 31 32 33 34 35 36 ; Barcode Data
37 38 39 30 35      ;

```



example 13: UPC-E, CD: Printer, HRI: none

Next example is that of the barcode data compacted in accordance with specifications by the printer.

1B 28 42 11 00 ; Barcode command and data length
04 ; Barcode type **k** = UPC-E
02 ; Module width **m** = 2 dots / 180 inch
00 ; Space adjustment value **s** = +0 dots / 360 inch
7D 00 ; Bar length **v1**, **v2** = 125 / 180 inch
03 ; Control flags **c**
31 32 33 34 35 36 ; Barcode Data
37 38 39 30 31 ;

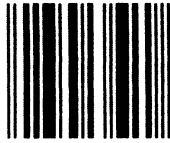

example 14: UPC-E, CD: Host, HRI: print

1B 28 42 0E 00 ; Barcode command and data length
04 ; Barcode type **k** = UPC-E
02 ; Module width **m** = 2 dots / 180 inch
00 ; Space adjustment value **s** = +0 dots / 360 inch
7D 00 ; Bar length **v1**, **v2** = 125 / 180 inch
00 ; Control flags **c**
30 31 32 33 34 35 ; Barcode Data
30 33 ;



example 15: UPC-E, CD: Printer, HRI: print

1B 28 42 0D 00 ; Barcode command and data length
04 ; Barcode type **k** = UPC-E
02 ; Module width **m** = 2 dots / 180 inch
00 ; Space adjustment value **s** = +0 dots / 360 inch
7D 00 ; Bar length **v1**, **v2** = 125 / 180 inch
01 ; Control flags **c**
30 31 32 33 34 35 30 ; Barcode Data



example 16: UPC-E, CD: printer, HRI: none

1B 28 42 0D 00 ; Barcode command and data length
04 ; Barcode type **k** = UPC-E
02 ; Module width **m** = 2 dots / 180 inch
00 ; Space adjustment value **s** = +0 dots / 360 inch
7D 00 ; Bar length **v1**, **v2** = 125 / 180 inch
03 ; Control flags **c**
30 31 32 33 34 35 30 ; Barcode Data

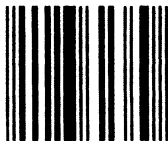

example 17: Code 39, CD: host, HRI: print

1B 28 42 0D 00 ; Barcode command and data length
05 ; Barcode type **k** = Code 39
02 ; Module width **m** = 2 dots / 180 inch
00 ; Space adjustment value **s** = +0 dots / 360 inch
7D 00 ; Bar length **v1**, **v2** = 125 / 180 inch
00 ; Control flags **c**
31 32 41 42 24 25 2E ; Barcode Data



example 18: Code 39, CD: Printer, HRI: print

1B 28 42 0D 00 ; Barcode command and data length
05 ; Barcode type **k** = Code 39
02 ; Module width **m** = 2 dots / 180 inch
00 ; Space adjustment value **s** = +0 dots / 360 inch
7D 00 ; Bar length **v1**, **v2** = 125 / 180 inch
01 ; Control flags **c**
31 32 41 42 24 25 2E ; Barcode Data



example 19: Code 39, CD: Printer, HRI: none

1B 28 42 0D 00 ; Barcode command and data length
05 ; Barcode type **k** = Code 39
02 ; Module width **m** = 2 dots / 180 inch
00 ; Space adjustment value **s** = +0 dots / 360 inch
7D 00 ; Bar length **v1**, **v2** = 125 / 180 inch
03 ; Control flags **c**
31 32 41 42 24 25 2E ; Barcode Data



example 20: Code 128, CD: Printer, HRI: print, using Data Character Set A

1B 28 42 10 00 ; Barcode command and data length
06 ; Barcode type **k** = Code 128
02 ; Module width **m** = 2 dots / 180 inch
00 ; Space adjustment value **s** = +0 dots / 360 inch
7D 00 ; Bar length **v1**, **v2** = 125 / 180 inch
01 ; Control flags **c**
41 32 33 40 41 21 43 ; Barcode Data
44 5B 5D ;



2 3 @ A ! C D [] 5

example 21: Code 128, CD: Printer, HRI: print, using Data Character Set B

1B 28 42 10 00 ; Barcode command and data length
06 ; Barcode type **k** = Code 128
02 ; Module width **m** = 2 dots / 180 inch
00 ; Space adjustment value **s** = +0 dots / 360 inch
7D 00 ; Bar length **v1**, **v2** = 125 / 180 inch
01 ; Control flags **c**
42 32 33 40 61 42 63 ; Barcode Data
44 5B 5D ;



2 3 @ a B c D [] Δ

example 22: Code 128, CD: Host, HRI: none, using Data Character Set B

1B 28 42 10 00 ; Barcode command and data length
06 ; Barcode type **k** = Code 128
02 ; Module width **m** = 2 dots / 180 inch
00 ; Space adjustment value **s** = +0 dots / 360 inch
7D 00 ; Bar length **v1**, **v2** = 125 / 180 inch
02 ; Control flags **c**
42 32 33 40 61 42 63 ; Barcode Data
44 5B 5D ;

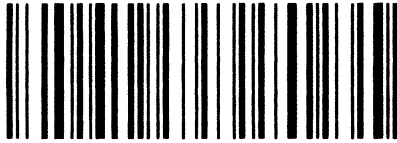

example 23: Code 128, CD: Host, HRI: print, using Data Character Set C

1B 28 42 11 00 ; Barcode command and data length
06 ; Barcode type **k** = Code 128
02 ; Module width **m** = 2 dots / 180 inch
00 ; Space adjustment value **s** = +0 dots / 360 inch
7D 00 ; Bar length **v1**, **v2** = 125 / 180 inch
00 ; Control flags **c**
43 30 31 32 33 34 35 ; Barcode Data
36 37 38 39 ;



example 24: Code 128, CD: Host, HRI: print, using Data Character Set C

Next example is of '0' added automatically, in the case of odd-numbered data.

1B 28 42 10 00 ; Barcode command and data length
06 ; Barcode type **k** = Code 128
02 ; Module width **m** = 2 dots / 180 inch
00 ; Space adjustment value **s** = +0 dots / 360 inch
7D 00 ; Bar length **v1**, **v2** = 125 / 180 inch
00 ; Control flags **c**
43 31 32 33 34 35 ; Barcode Data
36 37 38 39 ;



example 25: Code 128, CD: Host, HRI: print, mixed Data Character Set A, B and C

1B 28 42 14 00 ; Barcode command and data length
06 ; Barcode type **k** = Code 128
02 ; Module width **m** = 2 dots / 180 inch
00 ; Space adjustment value **s** = +0 dots / 360 inch
7D 00 ; Bar length **v1**, **v2** = 125 / 180 inch
00 ; Control flags **c**
41 30 62 61 64 70 1C ; Barcode Data
37 39 3A 62 1B 3D 61 ;

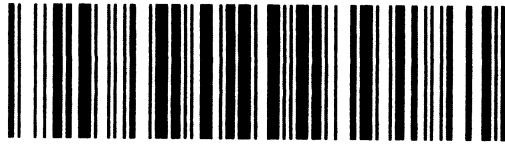

0 a p 79 b = a

example 26: POSTNET, CD: Host

1B 28 42 10 00 ; Barcode command and data length
07 ; Barcode type **k** = POSTNET
02 ; Module width **m** = 2 dots / 180 inch
00 ; Space adjustment value **s** = +0 dots / 360 inch
00 00 ; Bar length value **v1** and **v2** are ignored. POSTNET
uses the fixed bar length.
00 ; Control flags **c**
31 32 33 34 35 36 37 ; Barcode Data
38 39 30



example 27: POSTNET, CD: Printer

1B 28 42 0F 00 ; Barcode command and data length
07 ; Barcode type **k** = POSTNET
02 ; Module width **m** = 2 dots / 180 inch
00 ; Space adjustment value **s** = +0 dots / 360 inch
00 00 ; Bar length value **v1** and **v2** are ignored. POSTNET
uses the fixed bar length.
01 ; Control flags **c**
31 32 33 34 35 36 37 ; Barcode Data
38 39



Extended ESC/P 2 Programming Guide

To accommodate the high-resolution color graphics available to the Stylus COLOR and later inkjet printer models, EPSON has expanded the ESC/P 2 command set. The Stylus COLOR and later high-resolution ink jet printers are fully EPSON ESC/P 2 compliant. They support four multipoint fonts, the new MicroWeave command, and four raster graphics modes:

Standard raster graphics

Uncompressed raster graphics printing (ESC . 0)

Compressed raster graphics—Run Length Encoding (RLE) (ESC . 1)

Extended raster graphics (Stylus COLOR and later inkjet models only)

Compressed raster graphics—TIFF (ESC . 2)

To select one of these four raster graphics modes, set the *c* parameter in the print raster graphics command ESC . *c* *v* *h* *m* *n_L* *n_H* *d₁* . . . *d_k* as follows:

<i>c</i>	<i>mode</i>
0	Uncompressed raster graphics
1	RLE compression
2	TIFF compression

The TIFF mode command is only implemented in the Stylus COLOR and later inkjet model printers. These commands also make use of a subset of binary mode commands new to the ESC/P 2 command language. The Stylus COLOR is, of course, backward compatible with the ESC/P command language. To make full use of the new commands and features supported by the Stylus COLOR, we suggest writing an ESC/P 2 color printer driver specifically for this model. In addition, all future color printers, both ink jets and SIDMs, will include the expanded ESC/P 2 commands. By incorporating a new color printer driver in your application, you will be able to take full advantage of the program's powerful color features when printing with EPSON's high-resolution printers.

MicroWeave technology

The MicroWeave feature added to the ESC/P 2 command set reduces the banding—uniform horizontal lines in graphics—usually associated with serial printers. The command syntax is ESC (*i* 01 00 *n*, where *n* = 0 MicroWeave off (default), and *n* = 1 MicroWeave on. Banding is caused by the misalignment of printed dots at the boundary of two adjacent raster bands owing to mechanical limitations of the printer. MicroWeave technology compensates for these limitations by moving the print head in smaller vertical increments than the height of a non-MicroWeave raster band and firing the nozzles in a staggered sequence. This process shortens the band heights, making them less distinct.

To use MicroWeave, the band height (*m*) in the ESC . command must be set to 1. This feature also increases printing time, but it completely eliminates banding and yields sharp, near photographic-quality color images. For more information about this command, see its description in Individual Command Explanations.

Monochrome printing support

Black and white printing support for the Stylus COLOR can be achieved most easily by renaming an existing ESC/P 2 monochrome driver. The ESC/P 2 command language implements four scalable multipoint fonts: Roman, Sans Serif, Roman T, and Sans Serif H not available to ESC/P printers. In addition, ESC/P 2 printers support compressed graphics printing. In the monochrome multipoint mode, the Stylus COLOR printer supports the same four multipoint fonts available to current EPSON ESC/P 2 printers, including the LQ-150 (ActionPrinter 3260), LQ-570+ (ActionPrinter 5000+), LQ-1070+, Stylus 400, Stylus 800+, Stylus 1000, Stylus 800, and Stylus 300. However, in order to access the new extended raster graphics compressed modes, the driver should incorporate the latest ESC/P 2 commands, including ESC . 2.

Color bit-image graphics support

The best way to support color printing on the Stylus COLOR is to write a new driver that includes all of the expanded ESC/P 2 commands available to the Stylus COLOR and other high-resolution EPSON printers. A simpler although less desirable method of supporting color printing would be to rename an existing ESC/P color driver. Driver examples include the LQ-860 or LQ-2550. This method would support the Stylus COLOR as an older ESC/P bit-image printer but would seriously limit its high-resolution printing capabilities and deny access to other advanced features such as multipoint fonts, raster graphics data compression (RLE or TIFF), and MicroWeave.

ESC/P 2 color multipoint font support

Color multipoint font ESC/P 2 drivers can be developed by adding the select print color command (ESC r n) to existing black and white ESC/P 2 drivers. In multipoint mode, insert the select print color command using the values below.

<i>n</i>	<i>color</i>
0	Black (default)
1	Magenta
2	Cyan
3	Violet
4	Yellow
5	Red
6	Green

The Stylus COLOR uses process color inks—Cyan, Magenta, Yellow, and Black (CMYK)—to produce other colors, including Violet, Red, and Green. Existing printer drivers that can be modified to support color multipoint fonts are the LQ-150 (ActionPrinter 3260), LQ-570+ (ActionPrinter 5000+), LQ-1070+, Stylus 400, Stylus 800+, Stylus 1000, Stylus 800, and Stylus 300. For more information, see programming Example 1: ESC/P 2 color multipoint font driver. Also see the ESC r command description in Individual Command Explanations.

ESC/P 2 MicroWeave color raster graphics and RLE compressed raster graphics

Color raster graphics printing with MicroWeave requires the addition of the MicroWeave command “ESC (i 01 00 n” and the select color command “ESC r n” to an existing monochrome raster graphics driver. Only four colors are available when printing raster graphics.

<i>n</i>	<i>color</i>
0	Black (default)
1	Magenta
2	Cyan
4	Yellow

Note:

If you change the selected colors after entering raster graphics mode, the data buffer will be flushed.

Any of the following printer drivers can be modified to support MicroWeave color raster graphics printing: Stylus 400, Stylus 800+, Stylus 1000, Stylus 800, Stylus 300, LQ-570+ (ActionPrinter 5000+), LQ-1070+, LQ-150 (ActionPrinter 3260), and LQ-100 (ActionPrinter 3250). This mode can access the highest printing resolution (720 by 720 dpi) featured on EPSON’s latest color ink jet printers, such as the Stylus COLOR. See Example 2: MicroWeave ESC/P 2 color raster graphics and RLE compressed raster graphics driver for more information.

ESC/P 2 MicroWeave color extended raster graphics—TIFF

With the introduction of the Stylus COLOR, new compression method—TIFF—has been added to the existing ESC/P 2 graphics command set. To enter TIFF compressed mode, select the ESC . 2 extended raster graphics command. This compression architecture saves up to five bytes of overhead per raster line.

Note:

In TIFF compressed mode, the band height (m) must always be set to 1. In this setting, one raster line prints at a time.

The new compression mode supports the Stylus COLOR’s and later inkjet printers’ maximum resolution of 720 by 720 dpi and MicroWeave. The ESC . 2 extended raster graphics compression commands make use of a subset of binary mode commands new to ESC/P 2. These commands, which reduce the amount of code data that must be sent to the printer, are explained below.

Binary mode commands

The following binary commands are applicable to the TIFF compressed mode. All other commands are ignored after entering extended raster graphics.

<XFER>	Transfer raster graphics data
<MOVX>	Set relative horizontal position
<MOVY>	Set relative vertical position
<COLR>	Select printing color
<CR>	Carriage return to left-most print position
<EXIT>	Exit TIFF compressed mode
<MOVXBYTE>	Set <MOVX> unit to 8 dots
<MOVXDOT>	Set <MOVX> unit to 1 dot

The binary mode commands are divided into three classes:

<i>Class</i>	<i>Description</i>
1	command without parameter
2	command with parameter
3	command with parameter and data

Bit assignments

Bit assignments for the binary mode commands are as follows:

Class 1 commands (without parameter)

Bits 0–3	Command ID
Bit 4	Flag bit
Bits 5–7	Opcode

Class 2 commands (with parameter)

Bits 0–3	Parameter or counter
Bit 4	Flag bit
Bits 5–7	Opcode

Class 3 commands (with parameter and data)

Bits 0–3	Definition changes based on bit 4
Bit 4 = 0	Bits 0–3 are twos complement parameter
Bit 4 = 1	Bits 0–3 are parameter byte count
Bits 5–7	Opcode

System level commands

Class	Command	High nibble	Low nibble	Description
1	<CR>	1110	0010	Move to left most position (x = 0)
1	<EXIT>	1110	0011	Exit TIFF binary mode
1	<MOVXBYTE>	1110	0100	Horizontal (x) moves are in bytes
1	<MOVDOT>	1110	0101	Horizontal (x) moves are in dots

Movement commands

Class	Command	High nibble	Low nibble	Description
2	<MOVX>	0100	Count	Move -8 to +7 units (dots/bytes), default is dots
2	<MOVX>	0101	#BC	Move ±# units (dots/bytes), default is dots
2	<MOVY>	0110	Count	Move 0 to 15 units
2	<MOVY>	0111	#BC	Move # units

Graphics commands

Class	Command	High nibble	Low nibble	Description
3	<XFER>	0010	Count	Transfer 1–15 bytes of graphics data
3	<XFER>	0011	#BC	Transfer # bytes of graphics data
3	<COLR>	1000	Color	C,M,Y,K = 2, 1, 4, 0

Note:

When the color setting is changed with the <COLR> command, the print head moves to the left-most position (x = 0).

See Example 3 and the following feature comparison table for further information.

EPSON ESC/P Printer Feature Comparison Table

	Stylus COLOR	LQ-150 (AP-3260)	LQ-570+ (AP-5000+)	LQ-860/ LQ-2550	Stylus 300/ 800/1000
Serial Printer Technology	112 nozzle ink jet	24-pin impact	24-pin impact	24-pin impact	24-nozzle ink jet
Multipoint Fonts	4	4	4	0	4
Compressed Raster Graphics	TIFF, RLE	RLE	RLE	None	RLE
Color	Yes	Yes	No	Yes	No
MicroWeave	Yes	No	No	No	No
Max. Resolution (dpi) Color/Mono	720 × 720/ 720 × 720	360 × 180/ 360 × 360	N/A/360 × 360	360 × 180/ 360 × 360	N/A/ 360 × 360
Top/Bottom Margins	3/13 mm	5.3/9 mm	5.3/9 mm	8.5/13.5 mm	3/13 mm

Note:

Color printing is not available with the LQ-570+ (AP-5000+), Stylus 300, Stylus 400, Stylus 800, Stylus 800+, and Stylus 1000.

Programming examples

This section provides several programming examples that take advantage of the new features of the Stylus COLOR and later printer models. The following examples are not inclusive. Therefore, the specific driver commands you use will depend on the application.

Example 1: ESC/P 2 color multipoint font driver

Step 1 Start Job

ESC @ initialize the printer, reset printer to defaults

Step 2 Set Specific Configuration

ESC (U set units
ESC (t assign character table
ESC (C set page length in defined unit—continuous paper only
ESC (c set page format—top and bottom margins
ESC X set pitch before setting left and right margins (ESC P, ESC M, ESC g)
ESC l & ESC Q set left and right margins
ESC = set line spacing $n/360$ "

Step 3 Adjust Vertical Print Position (if necessary)

ESC (V absolute position in units
ESC (v relative position in units
LF line feed
FF form feed

Step 4 Adjust Horizontal Print Position (if necessary)

ESC \$ absolute position in units
ESC \ relative position in units
CR carriage return

Step 5 Output Text

ESC r n select printing color
where n = 0 Black
1 Magenta
2 Cyan
3 Violet
4 Yellow
5 Red
6 Green

ESC t	select character table
ESC X	select font by pitch and point—multipoint mode
ESC k	select typeface (see ESC k command description for latest font parameters)
ESC 4 & ESC 5	italic on/off
ESC E & ESC F	bold on/off
ESC (-	select line/score
ESC q	character style—outline/shadow

Send data to be printed

Repeat as necessary within line

Signal end of line—use CR, LF, or vertical positioning

Step 6 Repeat Above as Necessary within Page

Step 7 End Page

Send FF command

Prompt user for paper if in single-sheet mode

Step 8 End Job

ESC @ reset printer to defaults

Example 2: MicroWeave ESC/P 2 standard color raster graphics and RLE compressed raster graphics driver

Step 1 Start Job

ESC @ initialize the printer, reset printer to defaults

Step 2 Enter Raster Graphics Mode

ESC (G select graphics mode

Note:

- The appropriate driver commands depend on the application.
- New or expanded ESC/P 2 commands are shown in bold.

Step 3 Set Specific Configuration

ESC (i 01 00 n turn MicroWeave on/off
 where n = 0 MicroWeave off
 1 MicroWeave on

Note:

- If the EPSON ESC/P 2 printer does not support MicroWeave, it will ignore the ESC (i command. High-resolution color printers, including the Stylus COLOR, support MicroWeave.
- Execute the ESC (i command prior to paper feed.

ESC (U	set units
ESC (C	set page length in defined unit—continuous paper only
ESC (c	set page format—top and bottom margins
ESC U	turn unidirectional mode on/off

Adjust Vertical Print Position (if necessary)

ESC (V	absolute position in units
ESC (v	relative position in units
LF	line feed
FF	form feed

Step 4 Adjust Horizontal Print Position (if necessary)

ESC \$	absolute position in units
ESC \	relative position in units
CR	carriage return

Step 5 Output Raster Graphics

ESC \	relative horizontal position in units
ESC r n	select printing color
	where n = 0 Black
	1 Magenta
	2 Cyan
	4 Yellow
ESC .c	print raster graphics data
	where c = 0 uncompressed raster graphics
	1 compressed raster graphics (RLE)

Note:

Use data compression whenever possible to reduce file size and printing time.

CR	carriage return
----	-----------------

Repeat steps as necessary within a graphics block—start with yellow and then follow command sequence with magenta, cyan, and black. If necessary, signal the end of the graphics band with a CR, LF, or vertical positioning command.

Step 6 Repeat Above as Necessary within Page

Send FF command
 Prompt user for paper if in single-sheet mode

Step 7 End Job

ESC @	reset printer to defaults (exit raster graphics mode)
-------	---

Example 3: MicroWeave ESC/P 2 extended color raster graphics and TIFF compressed raster graphics driver

Step 1 Start Job

Send ESC @ to initialize the printer, reset printer to defaults

Step 2 Enter Raster Graphics Mode

Send ESC (G to select graphics mode

Note:

- The appropriate driver commands depend on the application.
- New or expanded ESC/P 2 commands are shown in bold.

Step 3 Set Specific Configuration

Send ESC (i 01 00 n to turn MicroWeave on/off
where n = 0 MicroWeave off
1 MicroWeave on

Note:

- If the EPSON ESC/P 2 printer does not support MicroWeave, it will ignore the command. The Stylus COLOR supports MicroWeave.
- Execute the ESC (i command prior to paper feed.

Send:

ESC (U to set units
ESC (C to set page length in defined unit—continuous paper only
ESC (c to set page format—top and bottom margins
ESC U to turn unidirectional mode on/off

Step 4 Enter TIFF Raster Graphics Mode

Send ESC . 2 to enter TIFF compressed raster graphics mode

Note:

Only binary commands can be used after entering TIFF compressed mode.

Send <**MOVXDOT**> or <**MOVXBYTE**> to set horizontal move units to one dot or eight dots (1 byte)

Send <**MOVY**> to move vertically to first line of the image block
Send <**COLR**> to select color (Black, Magenta, Cyan, or Yellow)
Send <**MOVX**> or <**CR**> to move horizontally to first part of image block
Send <**XFER**> to send TIFF raster graphics data
Repeat as necessary for the existing line of the image block.
Repeat as necessary for the existing image block

Step 5 Repeat Above as Necessary within Page

Step 6 End Page

Send **<EXIT>** to exit TIFF compressed raster graphics mode
Send FF command—eject paper
Prompt user for paper if in single-sheet mode

Step 7 Repeat Above as Necessary for the Job

Step 8 End Job

Send ESC @ to reset printer to defaults (exit raster graphics mode)

TIFF mode programming sequence

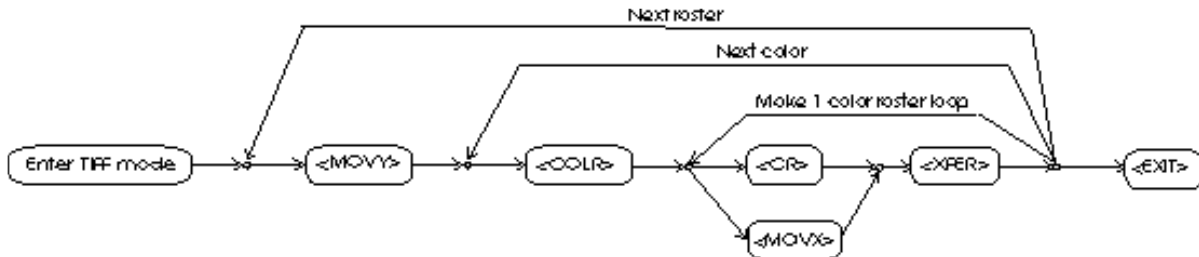

Command Table

24/48-Pin Printers.....T-2

9-Pin PrintersT-22

24/48-Pin Printers

		ESC/P 2															
		1997		1996		1995				1994							
S: Standard model N: NLSP model		S	N	S	N	S	N	S	N	S	N	S	N	S	N	S	N
		LQ-670	LQ-670	DLQ-3000 ('96-)	DLQ-3000 ('96-)	LQ-2070	LQ-2070	LQ-2170	LQ-2170	LQ-300	LQ-300	Stylus COL-OR	Stylus COL-OR	Stylus 400	Stylus 400	Stylus 800+	Stylus 800+
* BEL	Beeper	✓	✓	✓	✓	✓	✓	✓	✓	✓	✓	✓	✓	✓	✓	✓	✓
* BS	Backspace	✓	✓	✓	✓	✓	✓	✓	✓	✓	✓	✓	✓	✓	✓	✓	✓
HT	Tab horizontally	✓	✓	✓	✓	✓	✓	✓	✓	✓	✓	✓	✓	✓	✓	✓	✓
LF	Line feed	✓	✓	✓	✓	✓	✓	✓	✓	✓	✓	✓	✓	✓	✓	✓	✓
VT	Tab vertically	✓	✓	✓	✓	✓	✓	✓	✓	✓	✓	✓	✓	✓	✓	✓	✓
FF	Form feed	✓	✓	✓	✓	✓	✓	✓	✓	✓	✓	✓	✓	✓	✓	✓	✓
CR	Carriage return	✓	✓	✓	✓	✓	✓	✓	✓	✓	✓	✓	✓	✓	✓	✓	✓
SO	Select double-width printing (one line)	✓	✓	✓	✓	✓	✓	✓	✓	✓	✓	✓	✓	✓	✓	✓	✓
SI	Select condensed printing	✓	✓	✓	✓	✓	✓	✓	✓	✓	✓	✓	✓	✓	✓	✓	✓
* DC1	Select printer											✓	✓	✓	✓	✓	✓
DC2	Cancel condensed printing	✓	✓	✓	✓	✓	✓	✓	✓	✓	✓	✓	✓	✓	✓	✓	✓
* DC3	Deselect printer											✓	✓	✓	✓	✓	✓
DC4	Cancel double-width printing (one line)	✓	✓	✓	✓	✓	✓	✓	✓	✓	✓	✓	✓	✓	✓	✓	✓
* CAN	Cancel line	✓	✓	✓	✓	✓	✓	✓	✓	✓	✓	✓	✓	✓	✓	✓	✓
* ESC SO	Select double-width printing (one line)	✓	✓	✓	✓	✓	✓	✓	✓	✓	✓	✓	✓	✓	✓	✓	✓
* ESC SI	Select condensed printing	✓	✓	✓	✓	✓	✓	✓	✓	✓	✓	✓	✓	✓	✓	✓	✓
ESC EM	Control paper loading/ejecting	✓	✓	✓	✓	✓	✓	✓	✓	✓	✓	✓	✓	✓	✓	✓	✓
	0 Exit cut-sheet feeder mode																
	1 Select bin 1	✓	✓	✓	✓	✓	✓	✓	✓	✓	✓	✓	✓	✓	✓	✓	✓
	2 Select bin 2	✓	✓			✓	✓	✓	✓								
	4 Select cut-sheet feeder mode																
	B Load paper from rear tractor																
	F Load paper from front tractor																
	R Eject a sheet of paper	✓	✓	✓	✓	✓	✓	✓	✓	✓	✓	✓	✓	✓	✓	✓	✓
ESC SP	Set intercharacter space	✓	✓	✓	✓	✓	✓	✓	✓	✓	✓	✓	✓	✓	✓	✓	✓
ESC !	Master select	✓	✓	✓	✓	✓	✓	✓	✓	✓	✓	✓	✓	✓	✓	✓	✓
* ESC #	Cancel MSB control	✓	✓	✓	✓	✓	✓	✓	✓	✓	✓	✓	✓	✓	✓	✓	✓
ESC \$	Set absolute horizontal position	✓	✓	✓	✓	✓	✓	✓	✓	✓	✓	✓	✓	✓	✓	✓	✓
ESC %	Select user-defined characters	✓	✓	✓	✓	✓	✓	✓	✓	✓	✓	✓	✓	✓	✓	✓	✓
ESC &	Define user-defined characters	✓	✓	✓	✓	✓	✓	✓	✓	✓	✓	✓	✓	✓	✓	✓	✓
ESC (-	Select line/score	✓	✓	✓	✓	✓	✓	✓	✓	✓	✓	✓	✓	✓	✓	✓	✓
ESC (B	Bar Code setup and print	✓	✓	✓	✓	✓	✓	✓	✓								
ESC (C	Set page length in defined unit	✓	✓	✓	✓	✓	✓	✓	✓	✓	✓	✓	✓	✓	✓	✓	✓
ESC (G	Select graphics mode	✓	✓	✓	✓	✓	✓	✓	✓	✓	✓	✓	✓	✓	✓	✓	✓
ESC (U	Set unit	✓	✓	✓	✓	✓	✓	✓	✓	✓	✓	✓	✓	✓	✓	✓	✓
ESC (V	Set absolute vertical print position	✓	✓	✓	✓	✓	✓	✓	✓	✓	✓	✓	✓	✓	✓	✓	✓
ESC (c	Set page format	✓	✓	✓	✓	✓	✓	✓	✓	✓	✓	✓	✓	✓	✓	✓	✓
ESC (i	Select MicroWeave											✓	✓				
ESC (t	Assign character table	✓	✓	✓	✓	✓	✓	✓	✓	✓	✓	✓	✓	✓	✓	✓	✓
	0 0 Italic	✓	✓	✓	✓	✓	✓	✓	✓	✓	✓	✓	✓	✓	✓	✓	✓
	1 0 PC437 (US)	✓	✓	✓	✓	✓	✓	✓	✓	✓	✓	✓	✓	✓	✓	✓	✓
	1 16 PC437 (Greek)		✓		✓		✓		✓			✓			✓		✓
	2 0 PC932 (Japanese)																
	3 0 PC850 (Multilingual)	✓	✓	✓	✓	✓	✓	✓	✓	✓	✓	✓	✓	✓	✓	✓	✓
	4 0 PC851 (Greek)		✓				✓		✓			✓					✓
	5 0 PC853 (Turkish)		✓		✓		✓		✓			✓			✓		✓
	6 0 PC855 (Cyrillic)		✓		✓		✓		✓			✓			✓		✓
	7 0 PC860 (Portuguese)	✓	✓	✓	✓	✓	✓	✓	✓	✓	✓	✓	✓	✓	✓	✓	✓
	8 0 PC863 (Canadian-French)	✓	✓	✓	✓	✓	✓	✓	✓	✓	✓	✓	✓	✓	✓	✓	✓
	9 0 PC865 (Norwegian)	✓	✓	✓	✓	✓	✓	✓	✓	✓	✓	✓	✓	✓	✓	✓	✓
	10 0 PC852 (Eastern Europe)		✓		✓		✓		✓			✓			✓		✓
	11 0 PC857 (Turkish)		✓		✓		✓		✓			✓			✓		✓
	12 0 PC862 (Hebrew)																
	13 0 PC864 (Arabic)		✓		✓		✓		✓								
	13 32 PC AR864																
	14 0 PC866 (Russian)		✓		✓		✓		✓			✓			✓		✓
(continued)	14 16 (Bulgarian ASCII****)																

* Nonrecommended or deleted command

24/48-Pin Printers

S: Standard model N: NLSP model		1991						1990											
		S	S	S	S	S	S	S	S	S	S	S	S	S	S	S	S		
		LQ-450	LQ-510	LQ-550	LQ-1010	Action Printer 3000	Action Printer 4000	Action Printer 4500	LQ-200	LQ-400	LQ-860+	LQ-1060+	LQ-860	LQ-1060	LQ-850	LQ-1050	DLQ-2000	Action Printer 4000	Action Printer 4500
* BEL	Beeper	✓	✓	✓	✓	✓	✓	✓	✓	✓	✓	✓	✓	✓	✓	✓	✓	✓	✓
* BS	Backspace	✓	✓	✓	✓	✓	✓	✓	✓	✓	✓	✓	✓	✓	✓	✓	✓	✓	✓
HT	Tab horizontally	✓	✓	✓	✓	✓	✓	✓	✓	✓	✓	✓	✓	✓	✓	✓	✓	✓	✓
LF	Line feed	✓	✓	✓	✓	✓	✓	✓	✓	✓	✓	✓	✓	✓	✓	✓	✓	✓	✓
VT	Tab vertically	✓	✓	✓	✓	✓	✓	✓	✓	✓	✓	✓	✓	✓	✓	✓	✓	✓	✓
FF	Form feed	✓	✓	✓	✓	✓	✓	✓	✓	✓	✓	✓	✓	✓	✓	✓	✓	✓	✓
CR	Carriage return	✓	✓	✓	✓	✓	✓	✓	✓	✓	✓	✓	✓	✓	✓	✓	✓	✓	✓
SO	Select double-width printing (one line)	✓	✓	✓	✓	✓	✓	✓	✓	✓	✓	✓	✓	✓	✓	✓	✓	✓	✓
SI	Select condensed printing	✓	✓	✓	✓	✓	✓	✓	✓	✓	✓	✓	✓	✓	✓	✓	✓	✓	✓
* DC1	Select printer	✓	✓	✓	✓	✓	✓	✓	✓	✓	✓	✓	✓	✓	✓	✓	✓	✓	✓
DC2	Cancel condensed printing	✓	✓	✓	✓	✓	✓	✓	✓	✓	✓	✓	✓	✓	✓	✓	✓	✓	✓
* DC3	Deselect printer	✓	✓	✓	✓	✓	✓	✓	✓	✓	✓	✓	✓	✓	✓	✓	✓	✓	✓
DC4	Cancel double-width printing (one line)	✓	✓	✓	✓	✓	✓	✓	✓	✓	✓	✓	✓	✓	✓	✓	✓	✓	✓
* CAN	Cancel line	✓	✓	✓	✓	✓	✓	✓	✓	✓	✓	✓	✓	✓	✓	✓	✓	✓	✓
* ESC SO	Select double-width printing (one line)	✓	✓	✓	✓	✓	✓	✓	✓	✓	✓	✓	✓	✓	✓	✓	✓	✓	✓
* ESC SI	Select condensed printing	✓	✓	✓	✓	✓	✓	✓	✓	✓	✓	✓	✓	✓	✓	✓	✓	✓	✓
ESC EM	Control paper loading/ejecting	✓	✓	✓	✓	✓	✓	✓	✓	✓	✓	✓	✓	✓	✓	✓	✓	✓	✓
	0 Exit cut-sheet feeder mode	✓	✓	✓	✓	✓	✓	✓	✓	✓	✓	✓	✓	✓	✓	✓	✓	✓	✓
	1 Select bin 1	✓	✓	✓	✓	✓	✓	✓	✓	✓	✓	✓	✓	✓	✓	✓	✓	✓	✓
	2 Select bin 2													✓	✓				
	4 Select cut-sheet feeder mode	✓	✓	✓	✓	✓	✓	✓	✓	✓	✓	✓	✓	✓	✓	✓	✓	✓	✓
	B Load paper from rear tractor																		
	F Load paper from front tractor																		
	R Eject a sheet of paper	✓	✓	✓	✓	✓	✓	✓	✓	✓	✓	✓	✓	✓	✓	✓	✓	✓	✓
ESC SP	Set intercharacter space	✓	✓	✓	✓	✓	✓	✓	✓	✓	✓	✓	✓	✓	✓	✓	✓	✓	✓
ESC !	Master select	✓	✓	✓	✓	✓	✓	✓	✓	✓	✓	✓	✓	✓	✓	✓	✓	✓	✓
* ESC #	Cancel MSB control	✓	✓	✓	✓	✓	✓	✓	✓	✓	✓	✓	✓	✓	✓	✓	✓	✓	✓
ESC \$	Set absolute horizontal position	✓	✓	✓	✓	✓	✓	✓	✓	✓	✓	✓	✓	✓	✓	✓	✓	✓	✓
ESC %	Select user-defined characters	✓	✓	✓	✓	✓	✓	✓	✓	✓	✓	✓	✓	✓	✓	✓	✓	✓	✓
ESC &	Define user-defined characters	✓	✓	✓	✓	✓	✓	✓	✓	✓	✓	✓	✓	✓	✓	✓	✓	✓	✓
ESC (-	Select line/score	✓	✓	✓	✓	✓	✓	✓	✓	✓	✓	✓	✓	✓	✓	✓	✓	✓	✓
ESC (B	Bar code setup and print																		
ESC (C	Set page length in defined unit																		
ESC (G	Select graphics mode																		
ESC (U	Set unit																		
ESC (V	Set absolute vertical print position																		
ESC (c	Set page format																		
ESC (i	Select MicroWeave																		
ESC (t	Assign character table																		
	0 0 Italic																		
	1 0 PC437 (US)																		
	1 16 PC437 (Greek)																		
	2 0 PC932 (Japanese)																		
	3 0 PC850 (Multilingual)																		
	4 0 PC851 (Greek)																		
	5 0 PC853 (Turkish)																		
	6 0 PC855 (Cyrillic)																		
	7 0 PC860 (Portuguese)																		
	8 0 PC863 (Canadian-French)																		
	9 0 PC865 (Norwegian)																		
	10 0 PC852 (Eastern Europe)																		
	11 0 PC857 (Turkish)																		
	12 0 PC862 (Hebrew)																		
	13 0 PC864 (Arabic)																		
	13 32 PC AR864																		
	14 0 PC866 (Russian)																		
(continued)	14 16 (Bulgarian ASCII****)																		

* Nonrecommended or deleted command

24/48-Pin Printers

			ESC/P 2															
			1997		1996		1995				1994							
S: Standard model N: NLSP model			S	N	S	N	S	N	S	N	S	N	S	N	S	N	S	N
			LQ-670	LQ-670	DLQ-3000 ('96-)	DLQ-3000 ('96-)	LQ-2070	LQ-2070	LQ-2170	LQ-2170	LQ-300	LQ-300	Stylus COL-OR	Stylus COL-OR	Stylus 400	Stylus 400	Stylus 800+	Stylus 800+
ESC (t	14	32	PC866 LAT. (Latvian)	✓		✓			✓		✓							
(continued)	15	0	PC869 (Greek)	✓		✓			✓		✓					✓		✓
	16	0	USSR GOST (Russian)															
	17	0	ECMA-94-1															
	18	0	KU 42 (K.U.) (Thai)															
	19	0	TIS 11 (ISO-988) (Thai)															
	20	0	TIS 18 (GENERAL) (Thai)															
	21	0	TIS 17 (SIC STD.) (Thai)															
	22	0	TIS 13 (IBM STD.) (Thai)															
	23	0	TIS 16 (SIC OLD) (Thai)															
	24	0	PC 861 (Icelandic)	✓	✓	✓	✓	✓		✓	✓	✓	✓	✓	✓	✓	✓	✓
	25	0	BRASCI (Braz. Portuguese)	✓		✓		✓		✓		✓	✓	✓	✓	✓	✓	✓
	26	0	Abicom (Braz. Portuguese)	✓		✓		✓		✓		✓	✓	✓	✓	✓	✓	✓
	27	0	MAZOWIA (Poland)		✓		✓		✓		✓		✓			✓		✓
	28	0	Code MJK (CSFR)		✓		✓		✓		✓		✓			✓		✓
	29	7	ISO 8859-7 (Latin/Greek)		✓		✓		✓		✓		✓			✓		✓
	29	16	ISO 8859-1 (Latin 1)															
	30	0	TSM (Thai system manager)															
	31	0	ISO Latin 1 T (Turkish)		✓		✓		✓		✓		✓			✓		✓
	32	0	Bulgaria		✓		✓		✓		✓		✓			✓		✓
	33	0	Hebrew 7		✓													
	34	0	Hebrew 8		✓													
	35	0	Roman 8	✓		✓		✓		✓								
	36	0	PC774 (Lithuania)		✓		✓		✓		✓							
	37	0	Estonia (Estonia)		✓		✓		✓		✓							
	38	0	ISCII															
	39	0	PC-ISCII															
	40	0	PC APTEC		✓													
	41	0	PC708		✓													
	42	0	PC720		✓													
	112	0	OCR-B															
	127	1	ISO Latin 1	✓		✓		✓		✓								
	127	2	ISO 8859-2 (ISO Latin 2)		✓		✓		✓		✓							
	127	7	ISO Latin 7 (Greek)															
ESC (v			Set relative vertical print position	✓	✓	✓	✓	✓	✓	✓	✓	✓	✓	✓	✓	✓	✓	✓
ESC (^			Print data as characters	✓	✓	✓	✓	✓	✓	✓	✓	✓	✓	✓	✓	✓	✓	✓
ESC *			Select bit image	✓	✓	✓	✓	✓	✓	✓	✓	✓	✓	✓	✓	✓	✓	✓
			0	✓	✓	✓	✓	✓	✓	✓	✓	✓	✓	✓	✓	✓	✓	✓
			1	✓	✓	✓	✓	✓	✓	✓	✓	✓	✓	✓	✓	✓	✓	✓
			2	✓	✓	✓	✓	✓	✓	✓	✓	✓	✓	✓	✓	✓	✓	✓
			3	✓	✓	✓	✓	✓	✓	✓	✓	✓	✓	✓	✓	✓	✓	✓
			4	✓	✓	✓	✓	✓	✓	✓	✓	✓	✓	✓	✓	✓	✓	✓
			6	✓	✓	✓	✓	✓	✓	✓	✓	✓	✓	✓	✓	✓	✓	✓
			32	✓	✓	✓	✓	✓	✓	✓	✓	✓	✓	✓	✓	✓	✓	✓
			33	✓	✓	✓	✓	✓	✓	✓	✓	✓	✓	✓	✓	✓	✓	✓
			38	✓	✓	✓	✓	✓	✓	✓	✓	✓	✓	✓	✓	✓	✓	✓
			39	✓	✓	✓	✓	✓	✓	✓	✓	✓	✓	✓	✓	✓	✓	✓
			40	✓	✓	✓	✓	✓	✓	✓	✓	✓	✓	✓	✓	✓	✓	✓
			71										✓	✓	✓	✓	✓	✓
			72										✓	✓	✓	✓	✓	✓
			73										✓	✓	✓	✓	✓	✓
ESC +			Set n/360-inch line spacing	✓	✓	✓	✓	✓	✓	✓	✓	✓	✓	✓	✓	✓	✓	✓
ESC -			Turn underline on/off	✓	✓	✓	✓	✓	✓	✓	✓	✓	✓	✓	✓	✓	✓	✓

* Nonrecommended or deleted command

24/48-Pin Printers

S: Standard model N: NLSP model			1991							1990										
			S	S	S	S	S	S	S	S	S	S	S	S	S	S	S	S	S	
			LQ-450	LQ-510	LQ-550	LQ-1010	Action Printer 3000	Action Printer 4000	Action Printer 4500	LQ-200	LQ-400	LQ-860+	LQ-1060+	LQ-860	LQ-1060	LQ-850	LQ-1050	DLQ-2000	Action Printer 4000	Action Printer 4500
ESC (t	14	32	PC866 LAT. (Latvian)																	
(continued)	15	0	PC869 (Greek)																	
	16	0	USSR GOST (Russian)																	
	17	0	ECMA-94-1																	
	18	0	KU 42 (K.U.) (Thai)																	
	19	0	TIS 11 (ISO-988) (Thai)																	
	20	0	TIS 18 (GENERAL) (Thai)																	
	21	0	TIS 17 (SIC STD.) (Thai)																	
	22	0	TIS 13 (IBM STD.) (Thai)																	
	23	0	TIS 16 (SIC OLD) (Thai)																	
	24	0	PC 861 (Icelandic)																	
	25	0	BRASCI (Braz. Portuguese)																	
	26	0	Abicomp (Braz. Portuguese)																	
	27	0	MAZOWIA (Poland)																	
	28	0	Code MJK (CSFR)																	
	29	7	ISO 8859-7 (Latin/Greek)																	
	29	16	ISO 8859-1 (Latin 1)																	
	30	0	TSM (Thai system manager)																	
	31	0	ISO Latin 1T (Turkish)																	
	32	0	Bulgaria																	
	33	0	Hebrew 7																	
	34	0	Hebrew 8																	
	35	0	Roman 8																	
	36	0	PC774 (Lithuania)																	
	37	0	Estonia (Estonia)																	
	38	0	ISCII																	
	39	0	PC-ISCII																	
	40	0	PC APTEC																	
	41	0	PC708																	
	42	0	PC720																	
	112	0	OCR-B																	
	127	1	ISO Latin 1																	
	127	2	ISO 8859-2 (ISO Latin 2)																	
	127	7	ISO Latin 7 (Greek)																	
ESC (v			Set relative vertical print position																	
ESC (^			Print data as characters																	
ESC *	Select bit image		✓	✓	✓	✓	✓	✓	✓	✓	✓	✓	✓	✓	✓	✓	✓	✓	✓	✓
	0		✓	✓	✓	✓	✓	✓	✓	✓	✓	✓	✓	✓	✓	✓	✓	✓	✓	✓
	1		✓	✓	✓	✓	✓	✓	✓	✓	✓	✓	✓	✓	✓	✓	✓	✓	✓	✓
	2		✓	✓	✓	✓	✓	✓	✓	✓	✓	✓	✓	✓	✓	✓	✓	✓	✓	✓
	3		✓	✓	✓	✓	✓	✓	✓	✓	✓	✓	✓	✓	✓	✓	✓	✓	✓	✓
	4		✓	✓	✓	✓	✓	✓	✓	✓	✓	✓	✓	✓	✓	✓	✓	✓	✓	✓
	6		✓	✓	✓	✓	✓	✓	✓	✓	✓	✓	✓	✓	✓	✓	✓	✓	✓	✓
	32		✓	✓	✓	✓	✓	✓	✓	✓	✓	✓	✓	✓	✓	✓	✓	✓	✓	✓
	33		✓	✓	✓	✓	✓	✓	✓	✓	✓	✓	✓	✓	✓	✓	✓	✓	✓	✓
	38		✓	✓	✓	✓	✓	✓	✓	✓	✓	✓	✓	✓	✓	✓	✓	✓	✓	✓
	39		✓	✓	✓	✓	✓	✓	✓	✓	✓	✓	✓	✓	✓	✓	✓	✓	✓	✓
	40		✓	✓	✓	✓	✓	✓	✓	✓	✓	✓	✓	✓	✓	✓	✓	✓	✓	✓
	71																			
	72																			
	73																			
ESC +	Set n/360-inch line spacing		✓	✓	✓	✓		✓	✓			✓	✓	✓	✓	✓	✓	✓	✓	✓
ESC -	Turn underline on/off		✓	✓	✓	✓	✓	✓	✓	✓	✓	✓	✓	✓	✓	✓	✓	✓	✓	✓

* Nonrecommended or deleted command

24/48-Pin Printers

		ESC/P 2																
		1997		1996		1995				1994								
		S	N	S	N	S	N	S	N	S	N	S	N	S	N	S	N	
		LQ-670	LQ-670	DLQ-3000 (96-)	DLQ-3000 (96-)	LQ-2070	LQ-2070	LQ-2170	LQ-2170	LQ-300	LQ-300	Stylus COL-OR	Stylus COL-OR	Stylus 400	Stylus 400	Stylus 800+	Stylus 800+	
S: Standard model N: NLSP model																		
ESC .	Print raster graphics	✓	✓	✓	✓	✓	✓	✓	✓	✓	✓	✓	✓	✓	✓	✓	✓	✓
	0 Print uncompressed raster graphics	✓	✓	✓	✓	✓	✓	✓	✓	✓	✓	✓	✓	✓	✓	✓	✓	✓
	1 Enter RLE compression	✓	✓	✓	✓	✓	✓	✓	✓	✓	✓	✓	✓	✓	✓	✓	✓	✓
	2 Enter TIFF compression**											✓	✓					
* ESC /	Select vertical tab channel																	
ESC 0	Select 1/8-inch line spacing	✓	✓	✓	✓	✓	✓	✓	✓	✓	✓	✓	✓	✓	✓	✓	✓	✓
ESC 2	Select 1/6-inch line spacing	✓	✓	✓	✓	✓	✓	✓	✓	✓	✓	✓	✓	✓	✓	✓	✓	✓
ESC 3	Set n/180-inch line spacing	✓	✓	✓	✓	✓	✓	✓	✓	✓	✓	✓	✓	✓	✓	✓	✓	✓
ESC 4	Select italic font	✓	✓	✓	✓	✓	✓	✓	✓	✓	✓	✓	✓	✓	✓	✓	✓	✓
ESC 5	Cancel italic font	✓	✓	✓	✓	✓	✓	✓	✓	✓	✓	✓	✓	✓	✓	✓	✓	✓
ESC 6	Enable printing of upper control codes	✓	✓	✓	✓	✓	✓	✓	✓	✓	✓	✓	✓	✓	✓	✓	✓	✓
ESC 7	Enable upper control codes	✓	✓	✓	✓	✓	✓	✓	✓	✓	✓	✓	✓	✓	✓	✓	✓	✓
* ESC 8	Disable paper-out sensor																	
* ESC 9	Enable paper-out sensor																	
ESC :	Copy ROM to RAM	✓	✓	✓	✓	✓	✓	✓	✓	✓	✓	✓	✓	✓	✓	✓	✓	✓
	0 Roman	✓	✓	✓	✓	✓	✓	✓	✓	✓	✓	✓	✓	✓	✓	✓	✓	✓
	1 Sans Serif	✓	✓	✓	✓	✓	✓	✓	✓	✓	✓	✓	✓	✓	✓	✓	✓	✓
	2 Courier	✓	✓	✓	✓	✓	✓	✓	✓	✓	✓	✓	✓	✓	✓	✓	✓	✓
	3 Prestige	✓	✓	✓	✓	✓	✓	✓	✓	✓	✓	✓	✓	✓	✓	✓	✓	✓
	4 Script	✓	✓	✓	✓												✓	✓
	5 OCR-B	✓	✓	✓	✓			✓	✓	✓	✓							
	6 OCR-A									✓	✓							
	7 Orator																	
	8 Orator-S																	
	9 Script C	✓	✓			✓	✓	✓	✓	✓	✓							
	10 Roman T				✓							✓	✓	✓	✓	✓	✓	✓
	11 Sans Serif H			✓	✓							✓	✓	✓	✓	✓	✓	✓
* ESC <	Unidirectional mode (one line)	✓	✓	✓	✓	✓	✓	✓	✓	✓	✓	✓	✓	✓	✓	✓	✓	✓
* ESC =	Set MSB to 0	✓	✓	✓	✓	✓	✓	✓	✓	✓	✓	✓	✓	✓	✓	✓	✓	✓
* ESC >	Set MSB to 1	✓	✓	✓	✓	✓	✓	✓	✓	✓	✓	✓	✓	✓	✓	✓	✓	✓
* ESC ?	Reassign bit-image mode	✓	✓	✓	✓	✓	✓	✓	✓	✓	✓	✓	✓	✓	✓	✓	✓	✓
	0	✓	✓	✓	✓	✓	✓	✓	✓	✓	✓	✓	✓	✓	✓	✓	✓	✓
	1	✓	✓	✓	✓	✓	✓	✓	✓	✓	✓	✓	✓	✓	✓	✓	✓	✓
	2	✓	✓	✓	✓	✓	✓	✓	✓	✓	✓	✓	✓	✓	✓	✓	✓	✓
	3	✓	✓	✓	✓	✓	✓	✓	✓	✓	✓	✓	✓	✓	✓	✓	✓	✓
	4	✓	✓	✓	✓	✓	✓	✓	✓	✓	✓	✓	✓	✓	✓	✓	✓	✓
	6	✓	✓	✓	✓	✓	✓	✓	✓	✓	✓	✓	✓	✓	✓	✓	✓	✓
	32	✓	✓	✓	✓	✓	✓	✓	✓	✓	✓	✓	✓	✓	✓	✓	✓	✓
	33	✓	✓	✓	✓	✓	✓	✓	✓	✓	✓	✓	✓	✓	✓	✓	✓	✓
	38	✓	✓	✓	✓	✓	✓	✓	✓	✓	✓	✓	✓	✓	✓	✓	✓	✓
	39	✓	✓	✓	✓	✓	✓	✓	✓	✓	✓	✓	✓	✓	✓	✓	✓	✓
	40	✓	✓	✓	✓	✓	✓	✓	✓	✓	✓	✓	✓	✓	✓	✓	✓	✓
	71											✓	✓	✓	✓	✓	✓	✓
	72											✓	✓	✓	✓	✓	✓	✓
	73											✓	✓	✓	✓	✓	✓	✓
ESC @	Initialize printer	✓	✓	✓	✓	✓	✓	✓	✓	✓	✓	✓	✓	✓	✓	✓	✓	✓
* ESC A	Set n/60-inch line spacing	✓	✓	✓	✓	✓	✓	✓	✓	✓	✓	✓	✓	✓	✓	✓	✓	✓
ESC B	Set vertical tabs	✓	✓	✓	✓	✓	✓	✓	✓	✓	✓	✓	✓	✓	✓	✓	✓	✓
ESC C	Set page length in lines	✓	✓	✓	✓	✓	✓	✓	✓	✓	✓	✓	✓	✓	✓	✓	✓	✓
ESC C NUL	Set page length in inches	✓	✓	✓	✓	✓	✓	✓	✓	✓	✓	✓	✓	✓	✓	✓	✓	✓
ESC D	Set horizontal tabs	✓	✓	✓	✓	✓	✓	✓	✓	✓	✓	✓	✓	✓	✓	✓	✓	✓
ESC E	Select bold font	✓	✓	✓	✓	✓	✓	✓	✓	✓	✓	✓	✓	✓	✓	✓	✓	✓

* Nonrecommended or deleted command

** See the Command Summary and Recommended Operations sections for information on the binary commands used in these compression modes

24/48-Pin Printers

S: Standard model N: NLSP model		1991						1990											
		S	S	S	S	S	S	S	S	S	S	S	S	S	S	S	S		
		LQ-450	LQ-510	LQ-550	LQ-1010	Action Printer r 3000	Action Printer r 4000	Action Printer r 4500	LQ-200	LQ-400	LQ-860+	LQ-1060+	LQ-860	LQ-1060	LQ-850	LQ-1050	DLQ-2000	Action Printer r 4000	Action Printer r 4500
ESC .	Print raster graphics																		
	0 Print uncompressed raster graphics																		
	1 Enter RLE compression																		
	2 Enter TIFF compression**																		
* ESC /	Select vertical tab channel	✓	✓	✓	✓		✓	✓		✓	✓	✓	✓	✓	✓	✓	✓	✓	✓
ESC 0	Select 1/8-inch line spacing	✓	✓	✓	✓	✓	✓	✓	✓	✓	✓	✓	✓	✓	✓	✓	✓	✓	✓
ESC 2	Select 1/6-inch line spacing	✓	✓	✓	✓	✓	✓	✓	✓	✓	✓	✓	✓	✓	✓	✓	✓	✓	✓
ESC 3	Set n/180-inch line spacing	✓	✓	✓	✓	✓	✓	✓	✓	✓	✓	✓	✓	✓	✓	✓	✓	✓	✓
ESC 4	Select italic font	✓	✓	✓	✓	✓	✓	✓	✓	✓	✓	✓	✓	✓	✓	✓	✓	✓	✓
ESC 5	Cancel italic font	✓	✓	✓	✓	✓	✓	✓	✓	✓	✓	✓	✓	✓	✓	✓	✓	✓	✓
ESC 6	Enable printing of upper control codes	✓	✓	✓	✓	✓	✓	✓	✓	✓	✓	✓	✓	✓	✓	✓	✓	✓	✓
ESC 7	Enable upper control codes	✓	✓	✓	✓	✓	✓	✓	✓	✓	✓	✓	✓	✓	✓	✓	✓	✓	✓
* ESC 8	Disable paper-out sensor																		
* ESC 9	Enable paper-out sensor																		
ESC :	Copy ROM to RAM	✓	✓	✓	✓	✓	✓	✓	✓	✓	✓	✓	✓	✓	✓	✓	✓	✓	✓
	0 Roman	✓	✓	✓	✓	✓	✓	✓	✓	✓	✓	✓	✓	✓	✓	✓	✓	✓	✓
	1 Sans Serif	✓	✓	✓	✓	✓	✓	✓	✓	✓	✓	✓	✓	✓	✓	✓	✓	✓	✓
	2 Courier	✓	✓	✓	✓	✓	✓	✓	✓		★	★	★	★	★	★	✓	★	★
	3 Prestige	✓	✓	✓	✓	✓	✓	✓	✓		★	★	★	★	★	★	✓	★	★
	4 Script	✓	✓	✓	✓	✓	✓	✓	✓		★	★	★	★	★	★	✓	★	★
	5 OCR-B	✓	✓	✓	✓	✓	✓	✓	✓		★	★	★	★	★	★	✓	★	★
	6 OCR-A	✓	✓	✓	✓		✓	✓			★	★	★	★	★	★	✓	★	★
	7 Orator										★	★	★	★	★	★			
	8 Orator-S										★	★	★	★	★	★			
	9 Script C																		
	10 Roman T																		
	11 Sans Serif H																		
* ESC <	Unidirectional mode (one line)	✓	✓	✓	✓	✓	✓	✓	✓	✓	✓	✓	✓	✓	✓	✓	✓	✓	✓
* ESC =	Set MSB to 0	✓	✓	✓	✓	✓	✓	✓	✓	✓	✓	✓	✓	✓	✓	✓	✓	✓	✓
* ESC >	Set MSB to 1	✓	✓	✓	✓	✓	✓	✓	✓	✓	✓	✓	✓	✓	✓	✓	✓	✓	✓
* ESC ?	Reassign bit-image mode	✓	✓	✓	✓	✓	✓	✓	✓	✓	✓	✓	✓	✓	✓	✓	✓	✓	✓
	0	✓	✓	✓	✓	✓	✓	✓	✓	✓	✓	✓	✓	✓	✓	✓	✓	✓	✓
	1	✓	✓	✓	✓	✓	✓	✓	✓	✓	✓	✓	✓	✓	✓	✓	✓	✓	✓
	2	✓	✓	✓	✓	✓	✓	✓	✓	✓	✓	✓	✓	✓	✓	✓	✓	✓	✓
	3	✓	✓	✓	✓	✓	✓	✓	✓	✓	✓	✓	✓	✓	✓	✓	✓	✓	✓
	4	✓	✓	✓	✓	✓	✓	✓	✓	✓	✓	✓	✓	✓	✓	✓	✓	✓	✓
	6	✓	✓	✓	✓	✓	✓	✓	✓	✓	✓	✓	✓	✓	✓	✓	✓	✓	✓
	32	✓	✓	✓	✓	✓	✓	✓	✓								✓	✓	
	33	✓	✓	✓	✓	✓	✓	✓	✓								✓	✓	
	38	✓	✓	✓	✓	✓	✓	✓	✓									✓	✓
	39	✓	✓	✓	✓	✓	✓	✓	✓									✓	✓
	40	✓	✓	✓	✓	✓	✓	✓	✓									✓	✓
	71																		
	72																		
	73																		
ESC @	Initialize printer	✓	✓	✓	✓	✓	✓	✓	✓	✓	✓	✓	✓	✓	✓	✓	✓	✓	✓
* ESC A	Set n/60-inch line spacing	✓	✓	✓	✓	✓	✓	✓	✓	✓	✓	✓	✓	✓	✓	✓	✓	✓	✓
ESC B	Set vertical tabs	✓	✓	✓	✓	✓	✓	✓	✓	✓	✓	✓	✓	✓	✓	✓	✓	✓	✓
ESC C	Set page length in lines	✓	✓	✓	✓	✓	✓	✓	✓	✓	✓	✓	✓	✓	✓	✓	✓	✓	✓
ESC C NUL	Set page length in inches	✓	✓	✓	✓	✓	✓	✓	✓	✓	✓	✓	✓	✓	✓	✓	✓	✓	✓
ESC D	Set horizontal tabs	✓	✓	✓	✓	✓	✓	✓	✓	✓	✓	✓	✓	✓	✓	✓	✓	✓	✓
ESC E	Select bold font	✓	✓	✓	✓	✓	✓	✓	✓	✓	✓	✓	✓	✓	✓	✓	✓	✓	✓

* Nonrecommended or deleted command

** See the Command Summary and Recommended Operations sections for information on the binary commands used in these compression modes

★ Available only with the optional font cartridge installed

24/48-Pin Printers

		ESC/P 2															
		1997		1996		1995				1994							
S: Standard model N: NLSP model		S	N	S	N	S	N	S	N	S	N	S	N	S	N	S	N
		LQ-670	LQ-670	DLQ-3000 ('96-)	DLQ-3000 ('96-)	LQ-2070	LQ-2070	LQ-2170	LQ-2170	LQ-300	LQ-300	Stylus COL-OR	Stylus COL-OR	Stylus 400	Stylus 400	Stylus 800+	Stylus 800+
ESC F	Cancel bold font	✓	✓	✓	✓	✓	✓	✓	✓	✓	✓	✓	✓	✓	✓	✓	✓
ESC G	Select double-strike printing	✓	✓	✓	✓	✓	✓	✓	✓	✓	✓	✓	✓	✓	✓	✓	✓
ESC H	Cancel double-strike printing	✓	✓	✓	✓	✓	✓	✓	✓	✓	✓	✓	✓	✓	✓	✓	✓
ESC J	Advance print position	✓	✓	✓	✓	✓	✓	✓	✓	✓	✓	✓	✓	✓	✓	✓	✓
* ESC K	Select 60-dpi graphics	✓	✓	✓	✓	✓	✓	✓	✓	✓	✓	✓	✓	✓	✓	✓	✓
* ESC L	Select 120-dpi graphics	✓	✓	✓	✓	✓	✓	✓	✓	✓	✓	✓	✓	✓	✓	✓	✓
ESC M	Select 10.5-point, 12-cpi	✓	✓	✓	✓	✓	✓	✓	✓	✓	✓	✓	✓	✓	✓	✓	✓
ESC N	Set bottom margin	✓	✓	✓	✓	✓	✓	✓	✓	✓	✓	✓	✓	✓	✓	✓	✓
ESC O	Cancel bottom margin	✓	✓	✓	✓	✓	✓	✓	✓	✓	✓	✓	✓	✓	✓	✓	✓
ESC P	Select 10.5-point, 10-cpi	✓	✓	✓	✓	✓	✓	✓	✓	✓	✓	✓	✓	✓	✓	✓	✓
ESC Q	Set right margin	✓	✓	✓	✓	✓	✓	✓	✓	✓	✓	✓	✓	✓	✓	✓	✓
ESC R	Select an international character set	✓	✓	✓	✓	✓	✓	✓	✓	✓	✓	✓	✓	✓	✓	✓	✓
	0 USA	✓	✓	✓	✓	✓	✓	✓	✓	✓	✓	✓	✓	✓	✓	✓	✓
	1 France	✓	✓	✓	✓	✓	✓	✓	✓	✓	✓	✓	✓	✓	✓	✓	✓
	2 Germany	✓	✓	✓	✓	✓	✓	✓	✓	✓	✓	✓	✓	✓	✓	✓	✓
	3 United Kingdom	✓	✓	✓	✓	✓	✓	✓	✓	✓	✓	✓	✓	✓	✓	✓	✓
	4 Denmark I	✓	✓	✓	✓	✓	✓	✓	✓	✓	✓	✓	✓	✓	✓	✓	✓
	5 Sweden	✓	✓	✓	✓	✓	✓	✓	✓	✓	✓	✓	✓	✓	✓	✓	✓
	6 Italy	✓	✓	✓	✓	✓	✓	✓	✓	✓	✓	✓	✓	✓	✓	✓	✓
	7 Spain I	✓	✓	✓	✓	✓	✓	✓	✓	✓	✓	✓	✓	✓	✓	✓	✓
	8 Japan (English)	✓	✓	✓	✓	✓	✓	✓	✓	✓	✓	✓	✓	✓	✓	✓	✓
	9 Norway	✓	✓	✓	✓	✓	✓	✓	✓	✓	✓	✓	✓	✓	✓	✓	✓
	10 Denmark II	✓	✓	✓	✓	✓	✓	✓	✓	✓	✓	✓	✓	✓	✓	✓	✓
	11 Spain II	✓	✓	✓	✓	✓	✓	✓	✓	✓	✓	✓	✓	✓	✓	✓	✓
	12 Latin America	✓	✓	✓	✓	✓	✓	✓	✓	✓	✓	✓	✓	✓	✓	✓	✓
	13 Korea	✓	✓	✓	✓	✓	✓	✓	✓	✓	✓	✓	✓	✓	✓	✓	✓
	64 Legal	✓	✓	✓	✓	✓	✓	✓	✓	✓	✓	✓	✓	✓	✓	✓	✓
ESC S	Select superscript/subscript printing	✓	✓	✓	✓	✓	✓	✓	✓	✓	✓	✓	✓	✓	✓	✓	✓
ESC T	Cancel superscript/subscript printing	✓	✓	✓	✓	✓	✓	✓	✓	✓	✓	✓	✓	✓	✓	✓	✓
ESC U	Turn unidirectional mode on/off	✓	✓	✓	✓	✓	✓	✓	✓	✓	✓	✓	✓	✓	✓	✓	✓
ESC W	Turn double-width printing on/off	✓	✓	✓	✓	✓	✓	✓	✓	✓	✓	✓	✓	✓	✓	✓	✓
ESC X	Select font by pitch and point	✓	✓	✓	✓	✓	✓	✓	✓	✓	✓	✓	✓	✓	✓	✓	✓
* ESC Y	Select 120-dpi, double-speed graphics	✓	✓	✓	✓	✓	✓	✓	✓	✓	✓	✓	✓	✓	✓	✓	✓
* ESC Z	Select 240-dpi graphics	✓	✓	✓	✓	✓	✓	✓	✓	✓	✓	✓	✓	✓	✓	✓	✓
ESC \	Set relative horizontal print position	✓	✓	✓	✓	✓	✓	✓	✓	✓	✓	✓	✓	✓	✓	✓	✓
* ESC a	Select justification																
* ESC b	Set vertical tabs in VFU channels																
ESC c	Set horizontal motion index (HMI)	✓	✓	✓	✓	✓	✓	✓	✓	✓	✓	✓	✓	✓	✓	✓	✓
ESC g	Select 10.5-point, 15-cpi printing	✓	✓	✓	✓	✓	✓	✓	✓	✓	✓	✓	✓	✓	✓	✓	✓
ESC k	Select typeface	‡	‡	‡	‡	‡	‡	‡	‡	‡	‡	‡	‡	‡	‡	‡	‡
	0 Roman	‡	‡	‡	‡	‡	‡	‡	‡	‡	‡	‡	‡	‡	‡	‡	‡
	1 Sans serif	‡	‡	‡	‡	‡	‡	‡	‡	‡	‡	‡	‡	‡	‡	‡	‡
	2 Courier	✓	✓	✓	✓	✓	✓	✓	✓	✓	✓	✓	✓	✓	✓	✓	✓
	3 Prestige	✓	✓	✓	✓	✓	✓	✓	✓	✓	✓	✓	✓	✓	✓	✓	✓
	4 Script	✓	✓	✓	✓	✓	✓	✓	✓	✓	✓	✓	✓	✓	✓	✓	✓
	5 OCR-B	✓	✓	✓	✓	✓	✓	✓	✓								
	6 OCR-A																
	7 Orator	✓	✓	✓	✓	✓	✓	✓	✓								
	8 Orator-S	✓	✓	✓	✓	✓	✓	✓	✓								
	9 Script C	✓	✓	✓	✓	✓	✓	✓	✓								
	10 Roman T	✓	✓	✓	✓	✓	✓	✓	✓	✓	✓	✓	✓	✓	✓	✓	✓
	11 Sans Serif H	✓	✓	✓	✓	✓	✓	✓	✓	✓	✓	✓	✓	✓	✓	✓	✓
	30 SV Busaba																
	31 SV Jifra																

* Nonrecommended or deleted command
 ‡ Also available during multipoint (scalable font) mode

24/48-Pin Printers

S: Standard model N: NLSP model		1991						1990											
		S	S	S	S	S	S	S	S	S	S	S	S	S	S	S	S	S	
		LQ-450	LQ-510	LQ-550	LQ-1010	Action Printer 3000	Action Printer 4000	Action Printer 4500	LQ-200	LQ-400	LQ-860+	LQ-1060+	LQ-860	LQ-1060	LQ-850	LQ-1050	DLQ-2000	Action Printer 4000	Action Printer 4500
ESC F	Cancel bold font	✓	✓	✓	✓	✓	✓	✓	✓	✓	✓	✓	✓	✓	✓	✓	✓	✓	✓
ESC G	Select double-strike printing	✓	✓	✓	✓	✓	✓	✓	✓	✓	✓	✓	✓	✓	✓	✓	✓	✓	✓
ESC H	Cancel double-strike printing	✓	✓	✓	✓	✓	✓	✓	✓	✓	✓	✓	✓	✓	✓	✓	✓	✓	✓
ESC J	Advance print position	✓	✓	✓	✓	✓	✓	✓	✓	✓	✓	✓	✓	✓	✓	✓	✓	✓	✓
* ESC K	Select 60-dpi graphics	✓	✓	✓	✓	✓	✓	✓	✓	✓	✓	✓	✓	✓	✓	✓	✓	✓	✓
* ESC L	Select 120-dpi graphics	✓	✓	✓	✓	✓	✓	✓	✓	✓	✓	✓	✓	✓	✓	✓	✓	✓	✓
ESC M	Select 10.5-point, 12-cpi	✓	✓	✓	✓	✓	✓	✓	✓	✓	✓	✓	✓	✓	✓	✓	✓	✓	✓
ESC N	Set bottom margin	✓	✓	✓	✓	✓	✓	✓	✓	✓	✓	✓	✓	✓	✓	✓	✓	✓	✓
ESC O	Cancel bottom margin	✓	✓	✓	✓	✓	✓	✓	✓	✓	✓	✓	✓	✓	✓	✓	✓	✓	✓
ESC P	Select 10.5-point, 10-cpi	✓	✓	✓	✓	✓	✓	✓	✓	✓	✓	✓	✓	✓	✓	✓	✓	✓	✓
ESC Q	Set right margin	✓	✓	✓	✓	✓	✓	✓	✓	✓	✓	✓	✓	✓	✓	✓	✓	✓	✓
ESC R	Select an international character set	✓	✓	✓	✓	✓	✓	✓	✓	✓	✓	✓	✓	✓	✓	✓	✓	✓	✓
	0 USA	✓	✓	✓	✓	✓	✓	✓	✓	✓	✓	✓	✓	✓	✓	✓	✓	✓	✓
	1 France	✓	✓	✓	✓	✓	✓	✓	✓	✓	✓	✓	✓	✓	✓	✓	✓	✓	✓
	2 Germany	✓	✓	✓	✓	✓	✓	✓	✓	✓	✓	✓	✓	✓	✓	✓	✓	✓	✓
	3 United Kingdom	✓	✓	✓	✓	✓	✓	✓	✓	✓	✓	✓	✓	✓	✓	✓	✓	✓	✓
	4 Denmark I	✓	✓	✓	✓	✓	✓	✓	✓	✓	✓	✓	✓	✓	✓	✓	✓	✓	✓
	5 Sweden	✓	✓	✓	✓	✓	✓	✓	✓	✓	✓	✓	✓	✓	✓	✓	✓	✓	✓
	6 Italy	✓	✓	✓	✓	✓	✓	✓	✓	✓	✓	✓	✓	✓	✓	✓	✓	✓	✓
	7 Spain I	✓	✓	✓	✓	✓	✓	✓	✓	✓	✓	✓	✓	✓	✓	✓	✓	✓	✓
	8 Japan (English)	✓	✓	✓	✓	✓	✓	✓	✓	✓	✓	✓	✓	✓	✓	✓	✓	✓	✓
	9 Norway	✓	✓	✓	✓	✓	✓	✓	✓	✓	✓	✓	✓	✓	✓	✓	✓	✓	✓
	10 Denmark II	✓	✓	✓	✓	✓	✓	✓	✓	✓	✓	✓	✓	✓	✓	✓	✓	✓	✓
	11 Spain II	✓	✓	✓	✓	✓	✓	✓	✓	✓	✓	✓	✓	✓	✓	✓	✓	✓	✓
	12 Latin America	✓	✓	✓	✓	✓	✓	✓	✓	✓	✓	✓	✓	✓	✓	✓	✓	✓	✓
	13 Korea	✓	✓	✓	✓	✓	✓	✓	✓	✓	✓	✓	✓	✓	✓	✓	✓	✓	✓
	64 Legal	✓	✓	✓	✓	✓	✓	✓	✓	✓	✓	✓	✓	✓	✓	✓	✓	✓	✓
ESC S	Select superscript/subscript printing	✓	✓	✓	✓	✓	✓	✓	✓	✓	✓	✓	✓	✓	✓	✓	✓	✓	✓
ESC T	Cancel superscript/subscript printing	✓	✓	✓	✓	✓	✓	✓	✓	✓	✓	✓	✓	✓	✓	✓	✓	✓	✓
ESC U	Turn unidirectional mode on/off	✓	✓	✓	✓	✓	✓	✓	✓	✓	✓	✓	✓	✓	✓	✓	✓	✓	✓
ESC W	Turn double-width printing on/off	✓	✓	✓	✓	✓	✓	✓	✓	✓	✓	✓	✓	✓	✓	✓	✓	✓	✓
ESC X	Select font by pitch and point																		
* ESC Y	Select 120-dpi, double-speed graphics	✓	✓	✓	✓	✓	✓	✓	✓	✓	✓	✓	✓	✓	✓	✓	✓	✓	✓
* ESC Z	Select 240-dpi graphics	✓	✓	✓	✓	✓	✓	✓	✓	✓	✓	✓	✓	✓	✓	✓	✓	✓	✓
ESC \	Set relative horizontal print position	✓	✓	✓	✓	✓	✓	✓	✓	✓	✓	✓	✓	✓	✓	✓	✓	✓	✓
* ESC a	Select justification	✓	✓	✓	✓	✓	✓		✓	✓	✓	✓	✓	✓	✓	✓	✓	✓	✓
* ESC b	Set vertical tabs in VFU channels	✓	✓	✓	✓	✓	✓		✓	✓	✓	✓	✓	✓	✓	✓	✓	✓	✓
ESC c	Set horizontal motion index (HMI)																		
ESC g	Select 10.5-point, 15-cpi printing	✓	✓	✓	✓	✓	✓	✓	✓	✓	✓	✓	✓	✓	✓	✓	✓	✓	✓
ESC k	Select typeface	✓	✓	✓	✓	✓	✓	✓	✓	✓	✓	✓	✓	✓	✓	✓	✓	✓	✓
	0 Roman	✓	✓	✓	✓	✓	✓	✓	✓	✓	✓	✓	✓	✓	✓	✓	✓	✓	✓
	1 Sans serif	✓	✓	✓	✓	✓	✓	✓	✓	✓	✓	✓	✓	✓	✓	✓	✓	✓	✓
	2 Courier	✓	✓	✓	✓	✓	✓	✓	★	★	★	★	★	★	★	★	✓	★	★
	3 Prestige	✓	✓	✓	✓	✓	✓	✓	★	★	★	★	★	★	★	★	✓	★	★
	4 Script	✓	✓	✓	✓	✓	✓	✓	★	★	★	★	★	★	★	★	✓	★	★
	5 OCR-B	✓	✓	✓	✓	✓	✓	✓	★	★	★	★	★	★	★	★	✓	★	★
	6 OCR-A	✓	✓	✓	✓		✓	✓	★	★	★	★	★	★	★	✓	★	★	★
	7 Orator	✓	✓	✓	✓	✓	✓	✓	★	★	★	★	★	★	★	✓	★	★	★
	8 Orator-S	✓	✓	✓	✓		✓	✓	★	★	★	★	★	★	★	✓	★	★	★
	9 Script C																		
	10 Roman T																		
	11 Sans Serif H																		
	30 SV Busaba																		
	31 SV Jiffra																		

- * Nonrecommended or deleted command
- ★ Available only with the optional font cartridge installed
- 1 Available only during draft printing

24/48-Pin Printers

		ESC/P 2															
		1997		1996		1995				1994							
		S	N	S	N	S	N	S	N	S	N	S	N	S	N	S	N
		LQ-670	LQ-670	DLQ-3000 ('96-)	DLQ-3000 ('96-)	LQ-2070	LQ-2070	LQ-2170	LQ-2170	LQ-300	LQ-300	Stylus COL-COL-OR	Stylus COL-OR	Stylus 400	Stylus 400	Stylus 800+	Stylus 800+
S: Standard model N: NLSP model																	
ESC l	Set left margin	✓	✓	✓	✓	✓	✓	✓	✓	✓	✓	✓	✓	✓	✓	✓	✓
ESC p	Turn proportional mode on/off	✓	✓	✓	✓	✓	✓	✓	✓	✓	✓	✓	✓	✓	✓	✓	✓
ESC q	Select character style	✓	✓	✓	✓	✓	✓	✓	✓	✓	✓	✓	✓	✓	✓	✓	✓
ESC r	Select printing color			✓	✓					✓	✓	✓	✓				
* ESC s	Select low-speed mode																
ESC t	Select character table	✓	✓	✓	✓	✓	✓	✓	✓	✓	✓	✓	✓	✓	✓	✓	✓
	0 Table 0 Italic	✓	✓	✓	✓	✓	✓	✓	✓	✓	✓	✓	✓	✓	✓	✓	✓
	1 Table 1 Graphics	✓	✓	✓	✓	✓	✓	✓	✓	✓	✓	✓	✓	✓	✓	✓	✓
	2 Table 2 User-defined	✓	✓	✓	✓	✓	✓	✓	✓	✓	✓	✓	✓	✓	✓	✓	✓
	3 Table 3	✓	✓	✓	✓	✓	✓	✓	✓	✓	✓	✓	✓	✓	✓	✓	✓
ESC w	Turn double-height printing on/off	✓	✓	✓	✓	✓	✓	✓	✓	✓	✓	✓	✓	✓	✓	✓	✓
ESC x	Select letter quality or draft	✓	✓	✓	✓	✓	✓	✓	✓	✓	✓	✓	✓	✓	✓	✓	✓
* DEL	Delete last character in buffer	✓	✓	✓	✓	✓	✓	✓	✓	✓	✓	✓	✓	✓	✓	✓	✓

* Nonrecommended or deleted command

ESC/P 2																										
1993											1992					1991										
S	N	S	N	S	N	S	N	S	S	N	S	N	S	N	S	S	S	S	S	N	S	S	S	S		
Stylus 1000	Stylus 1000	LQ-1070+	LQ-1070+	DLQ-3000	DLQ-3000	Stylus 300	Stylus 300	Action Printer 3260	LQ-150	LQ-150	Stylus 800	Stylus 800	LQ-570+	LQ-570+	Action Printer 5000+	SQ-1170	SQ-870	Action Printer 3250	LQ-100	LQ-100	LQ-1070	LQ-870	LQ-1170	LQ-570	Action Printer 5500	Action Printer 5000
✓	✓	✓	✓	✓	✓	✓	✓	✓	✓	✓	✓	✓	✓	✓	✓	✓	✓	✓	✓	✓	✓	✓	✓	✓	✓	✓
✓	✓	✓	✓	✓	✓	✓	✓	✓	✓	✓	✓	✓	✓	✓	✓	✓	✓	✓	✓	✓	✓	✓	✓	✓	✓	✓
✓	✓	✓	✓	✓	✓	✓	✓	✓	✓	✓	✓	✓	✓	✓	✓	✓	✓	✓	✓	✓	✓	✓	✓	✓	✓	✓
✓	✓	✓	✓	✓	✓	✓	✓	✓	✓	✓	✓	✓	✓	✓	✓	✓	✓	✓	✓	✓	✓	✓	✓	✓	✓	✓
✓	✓	✓	✓	✓	✓	✓	✓	✓	✓	✓	✓	✓	✓	✓	✓	✓	✓	✓	✓	✓	✓	✓	✓	✓	✓	✓
✓	✓	✓	✓	✓	✓	✓	✓	✓	✓	✓	✓	✓	✓	✓	✓	✓	✓	✓	✓	✓	✓	✓	✓	✓	✓	✓
✓	✓	✓	✓	✓	✓	✓	✓	✓	✓	✓	✓	✓	✓	✓	✓	✓	✓	✓	✓	✓	✓	✓	✓	✓	✓	✓
✓	✓	✓	✓	✓	✓	✓	✓	✓	✓	✓	✓	✓	✓	✓	✓	✓	✓	✓	✓	✓	✓	✓	✓	✓	✓	✓
✓	✓	✓	✓	✓	✓	✓	✓	✓	✓	✓	✓	✓	✓	✓	✓	✓	✓	✓	✓	✓	✓	✓	✓	✓	✓	✓
✓	✓	✓	✓	✓	✓	✓	✓	✓	✓	✓	✓	✓	✓	✓	✓	✓	✓	✓	✓	✓	✓	✓	✓	✓	✓	✓
✓	✓	✓	✓	✓	✓	✓	✓	✓	✓	✓	✓	✓	✓	✓	✓	✓	✓	✓	✓	✓	✓	✓	✓	✓	✓	✓

24/48-Pin Printers

S: Standard model N: NLSP model		1991							1990										
		S	S	S	S	S	S	S	S	S	S	S	S	S	S	S	S	S	S
		LQ-450	LQ-510	LQ-550	LQ-1010	Action Printer 3000	Action Printer 4000	Action Printer 4500	LQ-200	LQ-400	LQ-860+	LQ-1060+	LQ-860	LQ-1060	LQ-850	LQ-1050	DLQ-2000	Action Printer 4000	Action Printer 4500
ESC l	Set left margin	✓	✓	✓	✓	✓	✓	✓	✓	✓	✓	✓	✓	✓	✓	✓	✓	✓	✓
ESC p	Turn proportional mode on/off	✓	✓	✓	✓	✓	✓	✓	✓	✓	✓	✓	✓	✓	✓	✓	✓	✓	✓
ESC q	Select character style	✓	✓	✓	✓	✓	✓	✓	✓	✓	✓	✓	✓	✓	✓	✓	✓	✓	✓
ESC r	Select printing color										✓	✓	✓	✓			✓		
* ESC s	Select low-speed mode																		
ESC t	Select character table	✓	✓	✓	✓	✓	✓	✓	✓	✓	✓	✓	✓	✓	✓	✓	✓	✓	✓
	0 Table 0 Italic	✓	✓	✓	✓	✓	✓	✓	✓	✓	✓	✓	✓	✓	✓	✓	✓	✓	✓
	1 Table 1 Graphics	✓	✓	✓	✓	✓	✓	✓	✓	✓	✓	✓	✓	✓	✓	✓	✓	✓	✓
	2 Table 2 User-defined	✓	✓	✓	✓	✓	✓	✓	✓	✓	✓	✓	✓	✓	✓	✓	✓	✓	✓
	3 Table 3																		
ESC w	Turn double-height printing on/off	✓	✓	✓	✓	✓	✓	✓	✓	✓	✓	✓	✓	✓	✓	✓	✓	✓	✓
ESC x	Select letter quality or draft	✓	✓	✓	✓	✓	✓	✓	✓	✓	✓	✓	✓	✓	✓	✓	✓	✓	✓
* DEL	Delete last character in buffer	✓	✓	✓	✓	✓	✓	✓	✓	✓	✓	✓	✓	✓	✓	✓	✓	✓	✓

* Nonrecommended or deleted command

1989										1988							1987		1986		1985			1983			
S	S	S	S	S	S	S	S	S	S	S	S	S	S	S	S	S	S	S	S	S	S	S	S	S	S	S	S
LQ-1010	LQ-850+	LQ-1050+	TSQ-4800	SQ-850	SQ-2550	LQ-550	LQ-860	LQ-1060	Action Printer L-750	TLQ-4800	LQ-2550	Action Printer L-1000	LQ-950	LQ-510	LQ-500	LQ-850	LQ-1050	SQ-2500	LQ-2500+	LQ-2500	P-80X	LQ-800	LQ-1000	SQ-2000	LQ-1500		
✓	✓	✓	✓	✓	✓	✓	✓	✓	✓	✓	✓	✓	✓	✓	✓	✓	✓	✓	✓	✓	✓	✓	✓	✓	✓	✓	✓
✓	✓	✓	✓	✓	✓	✓	✓	✓	✓	✓	✓	✓	✓	✓	✓	✓	✓	✓	✓	✓	✓	✓	✓	✓	✓	✓	✓
✓	✓	✓	✓	✓	✓	✓	✓	✓	✓	✓	✓	✓	✓	✓	✓	✓	✓	✓	✓	✓	✓	✓	✓	✓	✓	✓	✓
								✓	✓										✓	✓							
																			✓	✓							✓
✓	✓	✓	✓	✓	✓	✓	✓	✓	✓	✓	✓	✓	✓	✓	✓	✓	✓	✓	✓	✓	✓	✓	✓	✓	✓	✓	✓
✓	✓	✓	✓	✓	✓	✓	✓	✓	✓	✓	✓	✓	✓	✓	✓	✓	✓	✓	✓	✓	✓	✓	✓	✓	✓	✓	✓
✓	✓	✓	✓	✓	✓	✓	✓	✓	✓	✓	✓	✓	✓	✓	✓	✓	✓	✓	✓	✓	✓	✓	✓	✓	✓	✓	✓
✓	✓	✓	✓	✓	✓	✓	✓	✓	✓	✓	✓	✓	✓	✓	✓	✓	✓	✓	✓	✓	✓	✓	✓	✓	✓	✓	✓
✓	✓	✓	✓	✓	✓	✓	✓	✓	✓	✓	✓	✓	✓	✓	✓	✓	✓	✓	✓	✓	✓	✓	✓	✓	✓	✓	✓
✓	✓	✓	✓	✓	✓	✓	✓	✓	✓	✓	✓	✓	✓	✓	✓	✓	✓	✓	✓	✓	✓	✓	✓	✓	✓	✓	✓
✓	✓	✓	✓	✓	✓	✓	✓	✓	✓	✓	✓	✓	✓	✓	✓	✓	✓	✓	✓	✓	✓	✓	✓	✓	✓	✓	✓

9-Pin Printers

		1995		1994			1993			1992						
		S	N	S	N	S	S	N	S	S	N	S	S	N		
S: Standard model N: NLSP model		FX-2170	FX-2170	LX-300	LX-300	LX-1050+	DFX-5000+	DFX-5000+	FX-1170	FX-1170	FX-1170	FX-870	FX-870	Action Printer 2250	LX-100	LX-100
* BEL	Beeper	✓	✓	✓	✓	✓	✓	✓	✓	✓	✓	✓	✓	✓	✓	✓
* BS	Backspace	✓	✓	✓	✓	✓	✓	✓	✓	✓	✓	✓	✓	✓	✓	✓
HT	Tab horizontally	✓	✓	✓	✓	✓	✓	✓	✓	✓	✓	✓	✓	✓	✓	✓
LF	Line feed	✓	✓	✓	✓	✓	✓	✓	✓	✓	✓	✓	✓	✓	✓	✓
VT	Tab vertically	✓	✓	✓	✓	✓	✓	✓	✓	✓	✓	✓	✓	✓	✓	✓
FF	Form feed	✓	✓	✓	✓	✓	✓	✓	✓	✓	✓	✓	✓	✓	✓	✓
CR	Carriage return	✓	✓	✓	✓	✓	✓	✓	✓	✓	✓	✓	✓	✓	✓	✓
SO	Select double-width printing (one line)	✓	✓	✓	✓	✓	✓	✓	✓	✓	✓	✓	✓	✓	✓	✓
SI	Select condensed printing	✓	✓	✓	✓	✓	✓	✓	✓	✓	✓	✓	✓	✓	✓	✓
* DC1	Select printer	✓	✓	✓	✓	✓	✓	✓	✓	✓	✓	✓	✓	✓	✓	✓
DC2	Cancel condensed printing	✓	✓	✓	✓	✓	✓	✓	✓	✓	✓	✓	✓	✓	✓	✓
* DC3	Deselect printer	✓	✓	✓	✓	✓	✓	✓	✓	✓	✓	✓	✓	✓	✓	✓
DC4	Cancel double-width printing (one line)	✓	✓	✓	✓	✓	✓	✓	✓	✓	✓	✓	✓	✓	✓	✓
* CAN	Cancel line	✓	✓	✓	✓	✓	✓	✓	✓	✓	✓	✓	✓	✓	✓	✓
* ESC SO	Select double-width printing (one line)	✓	✓	✓	✓	✓	✓	✓	✓	✓	✓	✓	✓	✓	✓	✓
* ESC SI	Select condensed printing	✓	✓	✓	✓	✓	✓	✓	✓	✓	✓	✓	✓	✓	✓	✓
ESC EM	Control paper loading/ejecting	✓	✓	✓	✓	✓	✓	✓	✓	✓	✓	✓	✓	✓	✓	✓
	0 Exit cut-sheet feeder mode			✓	✓	✓	✓	✓	✓	✓	✓	✓	✓	✓	✓	✓
	1 Select bin 1	✓	✓						✓	✓	✓	✓	✓			
	2 Select bin 2	✓	✓						✓	✓	✓	✓	✓			
	4 Select cut-sheet feeder mode			✓	✓	✓	✓	✓	✓	✓	✓	✓	✓	✓	✓	✓
	B Load paper from rear tractor															
	F Load paper from front tractor															
	R Eject a sheet of paper	✓	✓						✓	✓	✓	✓	✓			
ESC SP	Set intercharacter space	✓	✓						✓	✓	✓	✓	✓			
ESC !	Master select	✓	✓	✓	✓	✓	✓	✓	✓	✓	✓	✓	✓	✓	✓	✓
* ESC #	Cancel MSB control	✓	✓						✓	✓	✓	✓	✓			
ESC \$	Set absolute horizontal position	✓	✓						✓	✓	✓	✓	✓			
ESC %	Select user-defined characters	✓	✓	✓	✓	✓	✓	✓	✓	✓	✓	✓	✓	✓	✓	✓
ESC &	Define user-defined characters	✓	✓	★	★	✓	✓	✓	✓	✓	✓	✓	✓	★	★	★
ESC (B	Bar Code setup and print	✓	✓													
ESC (t	Assign character table	✓	✓	✓	✓	✓	✓	✓	✓	✓	✓	✓	✓	✓	✓	✓
	0 0 Italic	✓	✓	✓	✓	✓	✓	✓	✓	✓	✓	✓	✓	✓	✓	✓
	1 0 PC437 (US)	✓	✓	✓	✓	✓	✓	✓	✓	✓	✓	✓	✓	✓	✓	✓
	1 16 PC437 (Greek)		✓		✓			✓		✓			✓			✓
	2 0 PC932 (Japanese)															
	3 0 PC850 (Multilingual)	✓	✓	✓	✓	✓	✓	✓	✓	✓	✓	✓	✓	✓	✓	✓
	4 0 PC851 (Greek)		✓		✓					✓			✓			✓
	5 0 PC853 (Turkish)		✓		✓			✓		✓			✓			✓
	6 0 PC855 (Cyrillic)		✓		✓			✓		✓			✓			✓
	7 0 PC860 (Portuguese)	✓	✓	✓	✓	✓	✓	✓	✓	✓	✓	✓	✓	✓	✓	✓
	8 0 PC863 (Canadian-French)	✓	✓	✓	✓	✓	✓	✓	✓	✓	✓	✓	✓	✓	✓	✓
	9 0 PC865 (Norwegian)	✓	✓	✓	✓	✓	✓	✓	✓	✓	✓	✓	✓	✓	✓	✓
	10 0 PC852 (Eastern Europe)		✓		✓			✓		✓			✓			✓
	11 0 PC857 (Turkish)		✓		✓			✓		✓			✓			✓
	12 0 PC862 (Hebrew)															
	13 0 PC864 (Arabic)															
	13 32 PC AR864															
	14 0 PC866 (Russian)		✓		✓			✓		✓			✓			✓
	14 16 (Bulgarian ASCII****)															
	14 32 PC866 LAT. (Latvian)		✓													
	15 0 PC869 (Greek)		✓		✓			✓		✓			✓			✓
	16 0 USSR GOST (Russian)		✓		✓					✓			✓			✓
	17 0 ECMA-94-1															
	18 0 KU 42 (K.U.) (Thai)															
(continued)	19 0 TIS 11 (ISO-988) (Thai)															

* Nonrecommended or deleted command

★ Only character codes 58 to 63 (decimal) can be defined with this command

9-Pin Printers

		1985					1984					1983					
		S	S	S	S	S	S	S	S	S	S	S	S	S	S	S	
S: Standard model N: NLSP model		HS-80	FX-286	FX-85	FX-185	P-80	RX-80 F/T+	RX-100	LX-80	FX-80+	FX-100+	JX-80	RX-80	RX-80 F/T	RX-100	FX-80	FX-100
* BEL	Beeper		✓	✓	✓		✓	✓	✓	✓	✓	✓	✓	✓	✓	✓	
* BS	Backspace	✓	✓	✓	✓		✓	✓	✓	✓	✓	✓	✓	✓	✓	✓	
HT	Tab horizontally	✓	✓	✓	✓	✓	✓	✓	✓	✓	✓	✓	✓	✓	✓	✓	
LF	Line feed	✓	✓	✓	✓	✓	✓	✓	✓	✓	✓	✓	✓	✓	✓	✓	
VT	Tab vertically	✓	✓	✓	✓		✓	✓	✓	✓	✓	✓	✓	✓	✓	✓	
FF	Form feed	✓	✓	✓	✓	✓	✓	✓	✓	✓	✓	✓	✓	✓	✓	✓	
CR	Carriage return	✓	✓	✓	✓	✓	✓	✓	✓	✓	✓	✓	✓	✓	✓	✓	
SO	Select double-width printing (one line)	✓	✓	✓	✓	✓	✓	✓	✓	✓	✓	✓	✓	✓	✓	✓	
SI	Select condensed printing	✓	✓	✓	✓	✓	✓	✓	✓	✓	✓	✓	✓	✓	✓	✓	
* DC1	Select printer	✓	✓	✓	✓		✓	✓	✓	✓	✓	✓	✓	✓	✓	✓	
DC2	Cancel condensed printing	✓	✓	✓	✓	✓	✓	✓	✓	✓	✓	✓	✓	✓	✓	✓	
* DC3	Deselect printer	✓	✓	✓	✓			✓	✓	✓	✓	✓	✓	✓	✓	✓	
DC4	Cancel double-width printing (one line)	✓	✓	✓	✓	✓	✓	✓	✓	✓	✓	✓	✓	✓	✓	✓	
* CAN	Cancel line	✓	✓	✓	✓		✓	✓	✓	✓	✓	✓	✓	✓	✓	✓	
* ESC SO	Select double-width printing (one line)	✓	✓	✓	✓		✓	✓				✓	✓	✓	✓	✓	
* ESC SI	Select condensed printing	✓	✓	✓	✓		✓	✓				✓	✓	✓	✓	✓	
ESC EM	Control paper loading/ejecting	✓	✓	✓	✓		✓	✓	✓	✓	✓						
	0 Exit cut-sheet feeder mode	✓	✓	✓	✓		✓	✓	✓	✓	✓						
	1 Select bin 1																
	2 Select bin 2																
	4 Select cut-sheet feeder mode	✓	✓	✓	✓		✓	✓	✓	✓	✓						
	B Load paper from rear tractor																
	F Load paper from front tractor																
	R Eject a sheet of paper																
ESC SP	Set intercharacter space		✓	✓	✓												
ESC !	Master select	✓	✓	✓	✓		✓	✓	✓	✓	✓						
* ESC #	Cancel MSB control	✓	✓	✓	✓					✓	✓						
ESC \$	Set absolute horizontal position		✓	✓	✓												
ESC %	Select user-defined characters	✓	✓	✓	✓				✓	✓	✓						
ESC &	Define user-defined characters	✓	✓	✓	✓				★	✓	✓						
ESC (B	Bar code setup and print																
ESC (t	Assign character table																
	0 0 Italic																
	1 0 PC437 (US)																
	1 16 PC437 (Greek)																
	2 0 PC932 (Japanese)																
	3 0 PC850 (Multilingual)																
	4 0 PC851 (Greek)																
	5 0 PC853 (Turkish)																
	6 0 PC855 (Cyrillic)																
	7 0 PC860 (Portugal)																
	8 0 PC863 (Canada-French)																
	9 0 PC865 (Norway)																
	10 0 PC852 (Eastern Europe)																
	11 0 PC857 (Turkish)																
	12 0 PC862 (Hebrew)																
	13 0 PC864 (Arabic)																
	13 32 PC AR864																
	14 0 PC866 (Russian)																
	14 16 (Bulgarian ASCII****)																
	14 32 PC866 LAT. (Latvian)																
	15 0 PC869 (Greek)																
	16 0 USSR GOST (Russian)																
	17 0 ECMA-94-1																
	18 0 KU 42 (K.U.) (Thai)																
(continued)	19 0 TIS 11 (ISO-988) (Thai)																

Not supported in the Command Summary or Recommended Operations sections

* Nonrecommended or deleted command

★ Only character codes 58 to 63 (decimal) can be defined with this command

9-Pin Printers

			1995		1994			1993		1992						
S: Standard model N: NLSP model			S	N	S	N	S	N	S	N	S	N	S	N	S	N
			FX-2170	FX-2170	LX-300	LX-300	LX-1050+	DFX-5000+	DFX-5000+	FX-1170	FX-1170	FX-870	FX-870	Action Printer 2250	LX-100	LX-100
ESC (t	20	0	TIS 18 (GENERAL) (Thai)													
(continued)	21	0	TIS 17 (SIC STD.) (Thai)													
	22	0	TIS 13 (IBM STD.) (Thai)													
	23	0	TIS 16 (SIC OLD) (Thai)													
	24	0	✓	✓		✓		✓	✓		✓		✓			✓
	25	0	✓		✓			✓	✓	✓		✓		✓		
	26	0	✓		✓			✓	✓	✓		✓		✓		
	27	0		✓		✓			✓							
	28	0		✓		✓			✓							
	29	7		✓		✓			✓							
	29	16	ISO 8859-1 (Latin 1)													
	30	0	TSM (Thai system manager)													
	31	0		✓		✓			✓							
	32	0		✓		✓			✓							
	33	0	Hebrew 7													
	34	0	Hebrew 8													
	35	0	✓													
	36	0		✓												
	37	0		✓												
	38	0	ISCII													
	39	0	PC-ISCII													
	40	0	PC APTEC													
	41	0	PC708													
	42	0	PC720													
	112	0	OCR-B													
	127	1	✓													
	127	2		✓												
	127	7	ISO Latin 7 (Greek)													
ESC *	Select bit image		✓	✓	✓	✓	✓	✓	✓	✓	✓	✓	✓	✓	✓	✓
	0		✓	✓	✓	✓	✓	✓	✓	✓	✓	✓	✓	✓	✓	✓
	1		✓	✓	✓	✓	✓	✓	✓	✓	✓	✓	✓	✓	✓	✓
	2		✓	✓	✓	✓	✓	✓	✓	✓	✓	✓	✓	✓	✓	✓
	3		✓	✓	✓	✓	✓	✓	✓	✓	✓	✓	✓	✓	✓	✓
	4		✓	✓	✓	✓	✓	✓	✓	✓	✓	✓	✓	✓	✓	✓
	5		✓	✓	✓	✓	✓	✓	✓	✓	✓	✓	✓	✓	✓	✓
	6		✓	✓	✓	✓	✓	✓	✓	✓	✓	✓	✓	✓	✓	✓
	7		✓	✓					✓	✓	✓	✓				
ESC -	Turn underline on/off		✓	✓	✓	✓	✓	✓	✓	✓	✓	✓	✓	✓	✓	✓
ESC /	Select vertical tab channel		✓	✓		✓	✓	✓	✓	✓	✓	✓	✓	✓	✓	✓
ESC 0	Select 1/8-inch line spacing		✓	✓	✓	✓	✓	✓	✓	✓	✓	✓	✓	✓	✓	✓
ESC 1	Select 7/72-inch line spacing		✓	✓	✓	✓	✓	✓	✓	✓	✓	✓	✓	✓	✓	✓
ESC 2	Select 1/6-inch line spacing		✓	✓	✓	✓	✓	✓	✓	✓	✓	✓	✓	✓	✓	✓
ESC 3	Set n/216-inch line spacing		✓	✓	✓	✓	✓	✓	✓	✓	✓	✓	✓	✓	✓	✓
ESC 4	Select italic font		✓	✓	✓	✓	✓	✓	✓	✓	✓	✓	✓	✓	✓	✓
ESC 5	Cancel italic font		✓	✓	✓	✓	✓	✓	✓	✓	✓	✓	✓	✓	✓	✓
ESC 6	Enable printing of upper control codes		✓	✓	✓	✓	✓	✓	✓	✓	✓	✓	✓	✓	✓	✓
ESC 7	Enable upper control codes		✓	✓	✓	✓	✓	✓	✓	✓	✓	✓	✓	✓	✓	✓
* ESC 8	Disable paper-out sensor		✓	✓	✓	✓	✓	✓	✓	✓	✓	✓	✓	✓	✓	✓
* ESC 9	Enable paper-out sensor		✓	✓	✓	✓	✓	✓	✓	✓	✓	✓	✓	✓	✓	✓
ESC :	Copy ROM to RAM		✓	✓	✓	✓	✓	✓	✓	✓	✓	✓	✓	✓	✓	✓
	0	Roman	✓	✓	✓	✓	✓	✓	✓	✓	✓	✓	✓	✓	✓	✓
	1	Sans serif	✓	✓	✓	✓	✓	✓	✓	✓	✓	✓	✓	✓	✓	✓
* ESC <	Unidirectional mode (one line)		✓	✓	✓	✓	✓	✓	✓	✓	✓	✓	✓	✓	✓	✓
* ESC =	Set MSB to 0		✓	✓					✓	✓	✓	✓				
* ESC >	Set MSB to 1		✓	✓					✓	✓	✓	✓				

* Nonrecommended or deleted command

9-Pin Printers

		1985					1984					1983					
		S	S	S	S	S	S	S	S	S	S	S	S	S	S	S	
S: Standard model N: NLSP model		HS-80	FX-286	FX-85	FX-185	P-80	RX-80 F/T+	RX-100	LX-80	FX-80+	FX-100+	JX-80	RX-80	RX-80 F/T	RX-100	FX-80	FX-100
ESC (t	20 0	TIS 18 (GENERAL) (Thai)															
(continued)	21 0	TIS 17 (SIC STD.) (Thai)															
	22 0	TIS 13 (IBM STD.) (Thai)															
	23 0	TIS 16 (SIC OLD) (Thai)															
	24 0	PC 861 (Icelandic)															
	25 0	BRASCI (Braz. Portuguese)															
	26 0	Abicomp (Braz. Portuguese)															
	27 0	MAZOWIA (Poland)															
	28 0	Code MJK (CSFR)															
	29 7	ISO 8859-7 (Latin/Greek)															
	29 16	ISO 8859-1 (Latin 1)															
	30 0	TSM (Thai system manager)															
	31 0	ISO Latin 1 T (Turkish)															
	32 0	Bulgaria															
	33 0	Hebrew 7															
	34 0	Hebrew 8															
	35 0	Roman 8															
	36 0	PC774 (Lithuania)															
	37 0	Estonia (Estonia)															
	38 0	ISCII															
	39 0	PC-ISCII															
	40 0	PC APTEC															
	41 0	PC708															
	42 0	PC720															
	112 0	OCR-B															
	127 1	ISO Latin 1															
	127 2	ISO 8859-2 (ISO Latin 2)															
	127 7	ISO Latin 7 (Greek)															
ESC *	Select bit image	✓	✓	✓	✓		✓	✓	✓	✓	✓	✓	✓	✓	✓	✓	
	0	✓	✓	✓	✓		✓	✓	✓	✓	✓	✓	✓	✓	✓	✓	
	1	✓	✓	✓	✓		✓	✓	✓	✓	✓	✓	✓	✓	✓	✓	
	2	✓	✓	✓	✓		✓	✓	✓	✓	✓	✓	✓	✓	✓	✓	
	3	✓	✓	✓	✓		✓	✓	✓	✓	✓	✓	✓	✓	✓	✓	
	4		✓	✓	✓		✓	✓	✓	✓	✓	✓	✓	✓	✓	✓	
	5		✓	✓	✓		✓	✓	✓	✓	✓	✓	✓	✓	✓	✓	
	6		✓	✓	✓		✓	✓	✓	✓	✓	✓	✓	✓	✓	✓	
	7		✓	✓	✓				✓	✓							
ESC -	Turn underline on/off	✓	✓	✓	✓	✓	✓	✓	✓	✓	✓	✓	✓	✓	✓	✓	
* ESC /	Select vertical tab channel	✓	✓	✓	✓		✓	✓	✓	✓	✓	✓				✓	
ESC 0	Select 1/8-inch line spacing	✓	✓	✓	✓	✓	✓	✓	✓	✓	✓	✓	✓	✓	✓	✓	
ESC 1	Select 7/72-inch line spacing	✓	✓	✓	✓		✓	✓	✓	✓	✓	✓	✓	✓	✓	✓	
ESC 2	Select 1/6-inch line spacing	✓	✓	✓	✓	✓	✓	✓	✓	✓	✓	✓	✓	✓	✓	✓	
ESC 3	Set n/216-inch line spacing	✓	✓	✓	✓	★	✓	✓	✓	✓	✓	✓	✓	✓	✓	✓	
ESC 4	Select italic font	✓	✓	✓	✓	✓	✓	✓	✓	✓	✓	✓	✓	✓	✓	✓	
ESC 5	Cancel italic font	✓	✓	✓	✓	✓	✓	✓	✓	✓	✓	✓	✓	✓	✓	✓	
ESC 6	Enable printing of upper control codes	✓	✓	✓	✓					✓	✓	✓				✓	
ESC 7	Enable upper control codes	✓	✓	✓	✓					✓	✓	✓				✓	
* ESC 8	Disable paper-out sensor		✓	✓	✓		✓	✓	✓	✓	✓	✓	✓	✓	✓	✓	
* ESC 9	Enable paper-out sensor		✓	✓	✓		✓	✓	✓	✓	✓	✓	✓	✓	✓	✓	
ESC :	Copy ROM to RAM	✓	✓	✓	✓				✓	✓	✓	✓				✓	
	0 Roman	✓	✓	✓	✓				✓	✓	✓	✓				✓	
	1 Sans serif																
* ESC <	Unidirectional mode (one line)		✓	✓	✓		✓	✓	✓	✓	✓	✓	✓	✓	✓	✓	
* ESC =	Set MSB to 0	✓	✓	✓	✓				✓	✓	✓					✓	
* ESC >	Set MSB to 1	✓	✓	✓	✓				✓	✓	✓					✓	

Not supported in the Command Summary or Recommended Operations sections

* Nonrecommended or deleted command

★ Selects n/180-inch spacing

9-Pin Printers

		1995		1994			1993		1992						
S: Standard model N: NLSP model		S	N	S	N	S	N	S	N	S	N	S	N	S	N
		FX-2170	FX-2170	LX-300	LX-300	LX-1050+	DFX-5000+	DFX-5000+	FX-1170	FX-1170	FX-870	FX-870	Action Printer 2250	LX-100	LX-100
* ESC ?	Reassign bit-image mode	✓	✓	✓	✓	✓	✓	✓	✓	✓	✓	✓	✓	✓	✓
*	0	✓	✓	✓	✓	✓	✓	✓	✓	✓	✓	✓	✓	✓	✓
*	1	✓	✓	✓	✓	✓	✓	✓	✓	✓	✓	✓	✓	✓	✓
*	2	✓	✓	✓	✓	✓	✓	✓	✓	✓	✓	✓	✓	✓	✓
*	3	✓	✓	✓	✓	✓	✓	✓	✓	✓	✓	✓	✓	✓	✓
*	4	✓	✓	✓	✓	✓	✓	✓	✓	✓	✓	✓	✓	✓	✓
*	5	✓	✓	✓	✓	✓	✓	✓	✓	✓	✓	✓	✓	✓	✓
*	6	✓	✓	✓	✓	✓	✓	✓	✓	✓	✓	✓	✓	✓	✓
*	7														
ESC @	Initialize printer	✓	✓	✓	✓	✓	✓	✓	✓	✓	✓	✓	✓	✓	✓
* ESC A	Set n/72-inch line spacing	✓	✓	✓	✓	✓	✓	✓	✓	✓	✓	✓	✓	✓	✓
ESC B	Set vertical tabs	✓	✓	✓	✓	✓	✓	✓	✓	✓	✓	✓	✓	✓	✓
ESC C	Set page length in lines	✓	✓	✓	✓	✓	✓	✓	✓	✓	✓	✓	✓	✓	✓
ESC C NUL	Set page length in inches	✓	✓	✓	✓	✓	✓	✓	✓	✓	✓	✓	✓	✓	✓
ESC D	Set horizontal tabs	✓	✓	✓	✓	✓	✓	✓	✓	✓	✓	✓	✓	✓	✓
ESC E	Select bold font	✓	✓	✓	✓	✓	✓	✓	✓	✓	✓	✓	✓	✓	✓
ESC F	Cancel bold font	✓	✓	✓	✓	✓	✓	✓	✓	✓	✓	✓	✓	✓	✓
ESC G	Select double-strike printing	✓	✓	✓	✓	✓	✓	✓	✓	✓	✓	✓	✓	✓	✓
ESC H	Cancel double-strike printing	✓	✓	✓	✓	✓	✓	✓	✓	✓	✓	✓	✓	✓	✓
ESC I	Select character/control codes	✓	✓						✓	✓	✓	✓			
ESC J	Advance print position	✓	✓	✓	✓	✓	✓	✓	✓	✓	✓	✓	✓	✓	✓
* ESC K	Select 60-dpi graphics	✓	✓	✓	✓	✓	✓	✓	✓	✓	✓	✓	✓	✓	✓
* ESC L	Select 120-dpi graphics	✓	✓	✓	✓	✓	✓	✓	✓	✓	✓	✓	✓	✓	✓
ESC M	Select 12-cpi	✓	✓	✓	✓	✓	✓	✓	✓	✓	✓	✓	✓	✓	✓
ESC N	Set bottom margin	✓	✓	✓	✓	✓	✓	✓	✓	✓	✓	✓	✓	✓	✓
ESC O	Cancel bottom margin	✓	✓	✓	✓	✓	✓	✓	✓	✓	✓	✓	✓	✓	✓
ESC P	Select 10-cpi	✓	✓	✓	✓	✓	✓	✓	✓	✓	✓	✓	✓	✓	✓
ESC Q	Set right margin	✓	✓	✓	✓	✓	✓	✓	✓	✓	✓	✓	✓	✓	✓
ESC R	Select an international character set	✓	✓	✓	✓	✓	✓	✓	✓	✓	✓	✓	✓	✓	✓
	0 USA	✓	✓	✓	✓	✓	✓	✓	✓	✓	✓	✓	✓	✓	✓
	1 France	✓	✓	✓	✓	✓	✓	✓	✓	✓	✓	✓	✓	✓	✓
	2 Germany	✓	✓	✓	✓	✓	✓	✓	✓	✓	✓	✓	✓	✓	✓
	3 United Kingdom	✓	✓	✓	✓	✓	✓	✓	✓	✓	✓	✓	✓	✓	✓
	4 Denmark I	✓	✓	✓	✓	✓	✓	✓	✓	✓	✓	✓	✓	✓	✓
	5 Sweden	✓	✓	✓	✓	✓	✓	✓	✓	✓	✓	✓	✓	✓	✓
	6 Italy	✓	✓	✓	✓	✓	✓	✓	✓	✓	✓	✓	✓	✓	✓
	7 Spain I	✓	✓	✓	✓	✓	✓	✓	✓	✓	✓	✓	✓	✓	✓
	8 Japan (English)	✓	✓	✓	✓	✓	✓	✓	✓	✓	✓	✓	✓	✓	✓
	9 Norway	✓	✓	✓	✓	✓	✓	✓	✓	✓	✓	✓	✓	✓	✓
	10 Denmark II	✓	✓	✓	✓	✓	✓	✓	✓	✓	✓	✓	✓	✓	✓
	11 Spain II	✓	✓	✓	✓	✓	✓	✓	✓	✓	✓	✓	✓	✓	✓
	12 Latin America	✓	✓	✓	✓	✓	✓	✓	✓	✓	✓	✓	✓	✓	✓
ESC S	Select superscript/subscript printing	✓	✓	✓	✓	✓	✓	✓	✓	✓	✓	✓	✓	✓	✓
ESC T	Cancel superscript/subscript printing	✓	✓	✓	✓	✓	✓	✓	✓	✓	✓	✓	✓	✓	✓
ESC U	Turn unidirectional mode on/off	✓	✓	✓	✓	✓	✓	✓	✓	✓	✓	✓	✓	✓	✓
ESC W	Turn double-width printing on/off	✓	✓	✓	✓	✓	✓	✓	✓	✓	✓	✓	✓	✓	✓
* ESC Y	Select 120-dpi, double-speed graphics	✓	✓	✓	✓	✓	✓	✓	✓	✓	✓	✓	✓	✓	✓
* ESC Z	Select 240-dpi graphics	✓	✓	✓	✓	✓	✓	✓	✓	✓	✓	✓	✓	✓	✓
ESC \	Set relative horizontal print position	✓	✓						✓	✓	✓	✓			
ESC ^	60 or 120-dpi graphics	✓	✓	✓	✓	✓	✓	✓	✓	✓	✓	✓	✓	✓	✓
* ESC a	Select justification	✓	✓	✓	✓	✓	✓	✓	✓	✓	✓	✓	✓	✓	✓
* ESC b	Set vertical tabs in VFU channels	✓	✓	✓	✓	✓	✓	✓	✓	✓	✓	✓	✓	✓	✓
ESC e	Set fixed vertical tab increment			✓	✓	✓							✓	✓	✓
ESC f	Horizontal/vertical skip			✓	✓	✓							✓	✓	✓

* Nonrecommended or deleted command

9-Pin Printers

S: Standard model N: NLSP model		1985					1984					1983					
		S	S	S	S	S	S	S	S	S	S	S	S	S	S		
		HS-80	FX-286	FX-85	FX-185	P-80	RX-80 F/T+	RX-100	LX-80	FX-80+	FX-100+	JX-80	RX-80	RX-80 F/T	RX-100	FX-80	FX-100
* ESC ?	Reassign bit-image mode		✓	✓	✓		✓	✓	✓	✓	✓	✓				✓	✓
*	0		✓	✓	✓		✓	✓	✓	✓	✓	✓				✓	✓
*	1		✓	✓	✓		✓	✓	✓	✓	✓	✓				✓	✓
*	2		✓	✓	✓		✓	✓	✓	✓	✓	✓				✓	✓
*	3		✓	✓	✓		✓	✓	✓	✓	✓	✓				✓	✓
*	4		✓	✓	✓		✓	✓	✓	✓	✓	✓				✓	✓
*	5		✓	✓	✓		✓	✓	✓	✓	✓	✓				✓	✓
*	6		✓	✓	✓		✓	✓	✓	✓	✓	✓				✓	✓
*	7									✓	✓						
	ESC @ Initialize printer	✓	✓	✓	✓	✓	✓	✓	✓	✓	✓	✓	✓	✓	✓	✓	✓
*	ESC A Set n/72-inch line spacing	✓	✓	✓	✓	✓	✓	✓	✓	✓	✓	✓	✓	✓	✓	✓	✓
	ESC B Set vertical tabs	✓	✓	✓	✓		✓	✓	✓	✓	✓	✓				✓	✓
	ESC C Set page length in lines	✓	✓	✓	✓	✓	✓	✓	✓	✓	✓	✓	✓	✓	✓	✓	✓
	ESC C Set page length in inches	✓	✓	✓	✓	✓	✓	✓	✓	✓	✓	✓	✓	✓	✓	✓	✓
	NUL																
	ESC D Set horizontal tabs	✓	✓	✓	✓		✓	✓	✓	✓	✓	✓				✓	✓
	ESC E Select bold font	✓	✓	✓	✓	✓	✓	✓	✓	✓	✓	✓	✓	✓	✓	✓	✓
	ESC F Cancel bold font	✓	✓	✓	✓	✓	✓	✓	✓	✓	✓	✓	✓	✓	✓	✓	✓
	ESC G Select double-strike printing	✓	✓	✓	✓	✓	✓	✓	✓	✓	✓	✓	✓	✓	✓	✓	✓
	ESC H Cancel double-strike printing	✓	✓	✓	✓	✓	✓	✓	✓	✓	✓	✓	✓	✓	✓	✓	✓
	ESC I Select character/control codes	✓	✓	✓	✓					✓	✓	✓				✓	✓
	ESC J Advance print position	✓	✓	✓	✓		✓	✓	✓	✓	✓	✓	✓	✓	✓	✓	✓
*	ESC K Select 60-dpi graphics	✓	✓	✓	✓	✓	✓	✓	✓	✓	✓	✓	✓	✓	✓	✓	✓
*	ESC L Select 120-dpi graphics	✓	✓	✓	✓	✓	✓	✓	✓	✓	✓	✓	✓	✓	✓	✓	✓
	ESC M Select 10.5-point, 12-cpi	✓	✓	✓	✓		✓	✓	✓	✓	✓	✓	✓	✓	✓	✓	✓
	ESC N Set bottom margin	✓	✓	✓	✓		✓	✓	✓	✓	✓	✓	✓	✓	✓	✓	✓
	ESC O Cancel bottom margin	✓	✓	✓	✓		✓	✓	✓	✓	✓	✓	✓	✓	✓	✓	✓
	ESC P Select 10.5-point, 10-cpi	✓	✓	✓	✓		✓	✓	✓	✓	✓	✓	✓	✓	✓	✓	✓
	ESC Q Set right margin	✓	✓	✓	✓		✓	✓	✓	✓	✓	✓	✓	✓	✓	✓	✓
	ESC R Select an international character set	✓	✓	✓	✓	✓	✓	✓	✓	✓	✓	✓	✓	✓	✓	✓	✓
	0 USA	✓	✓	✓	✓	✓	✓	✓	✓	✓	✓	✓	✓	✓	✓	✓	✓
	1 France	✓	✓	✓	✓	✓	✓	✓	✓	✓	✓	✓	✓	✓	✓	✓	✓
	2 Germany	✓	✓	✓	✓	✓	✓	✓	✓	✓	✓	✓	✓	✓	✓	✓	✓
	3 United Kingdom	✓	✓	✓	✓	✓	✓	✓	✓	✓	✓	✓	✓	✓	✓	✓	✓
	4 Denmark I	✓	✓	✓	✓	✓	✓	✓	✓	✓	✓	✓	✓	✓	✓	✓	✓
	5 Sweden	✓	✓	✓	✓	✓	✓	✓	✓	✓	✓	✓	✓	✓	✓	✓	✓
	6 Italy	✓	✓	✓	✓	✓	✓	✓	✓	✓	✓	✓	✓	✓	✓	✓	✓
	7 Spain I	✓	✓	✓	✓	✓	✓	✓	✓	✓	✓	✓	✓	✓	✓	✓	✓
	8 Japan (English)		✓	✓	✓		✓	✓	✓	✓	✓	✓	✓	✓	✓	✓	✓
	9 Norway		✓	✓	✓		✓	✓	✓	✓	✓	✓	✓	✓	✓	✓	✓
	10 Denmark II		✓	✓	✓		✓	✓	✓	✓	✓	✓	✓	✓	✓	✓	✓
	11 Spain II																
	12 Latin America																
	ESC S Select superscript/subscript printing	✓	✓	✓	✓		✓	✓	✓	✓	✓	✓	✓	✓	✓	✓	✓
	ESC T Cancel superscript/subscript printing	✓	✓	✓	✓		✓	✓	✓	✓	✓	✓	✓	✓	✓	✓	✓
	ESC U Turn unidirectional mode on/off		✓	✓	✓		✓	✓	✓	✓	✓	✓	✓	✓	✓	✓	✓
	ESC W Turn double-width printing on/off	✓	✓	✓	✓	✓	✓	✓	✓	✓	✓	✓	✓	✓	✓	✓	✓
*	ESC Y Select 120-dpi, double-speed graphics	✓	✓	✓	✓		✓	✓	✓	✓	✓	✓	✓	✓	✓	✓	✓
*	ESC Z Select 240-dpi graphics	✓	✓	✓	✓		✓	✓	✓	✓	✓	✓	✓	✓	✓	✓	✓
	ESC \ Set relative horizontal print position		✓	✓	✓												
	ESC ^ 60 or 120-dpi graphics	✓	✓	✓	✓		✓	✓	✓	✓	✓	✓				✓	✓
*	ESC a Select justification		✓	✓	✓				✓								
*	ESC b Set vertical tabs in VFU channels	✓	✓	✓	✓		✓	✓	✓	✓	✓	✓				✓	✓
	ESC e Set fixed vertical tab increment						✓	✓	✓				✓	✓	✓		
	ESC f Horizontal/vertical skip						✓	✓	✓				✓	✓	✓		

Not supported in the Command Summary or Recommended Operations sections

*Nonrecommended or deleted command

9-Pin Printers

S: Standard model N: NLSP model		1995		1994			1993		1992						
		S	N	S	N	S	S	N	S	N	S	S	N		
		FX-2170	FX-2170	LX-300	LX-300	LX-1050+	DFX-5000+	DFX-5000+	FX-1170	FX-1170	FX-870	FX-870	Action Printer 2250	LX-100	LX-100
ESC g	Select 15-cpi	✓	✓				✓	✓							
ESC l	Select immediate print mode	✓	✓												
* ESC j	Reverse paper feed	✓	✓												
ESC k	Select typeface	✓	✓	✓	✓	✓	✓	✓	✓	✓	✓	✓	✓	✓	✓
	0 Roman	✓	✓	✓	✓	✓	✓	✓	✓	✓	✓	✓	✓	✓	✓
	1 Sans serif	✓	✓	✓	✓	✓	✓	✓	✓	✓	✓	✓	✓	✓	✓
ESC l	Set left margin	✓	✓	✓	✓	✓	✓	✓	✓	✓	✓	✓	✓	✓	✓
ESC m	Select printing of upper control codes	✓	✓												
ESC p	Turn proportional mode on/off	✓	✓						✓	✓	✓	✓			
ESC r	Select printing color			✓	✓										
* ESC s	Select low-speed mode			✓	✓	✓	✓	✓	✓	✓	✓	✓	✓	✓	✓
ESC t	Select character table	✓	✓	✓	✓	✓	✓	✓	✓	✓	✓	✓	✓	✓	✓
	0 Table 0 Italic	✓	✓	✓	✓	✓	✓	✓	✓	✓	✓	✓	✓	✓	✓
	1 Table 1 Graphics	✓	✓	✓	✓	✓	✓	✓	✓	✓	✓	✓	✓	✓	✓
ESC w	Turn double-height printing on/off	✓	✓						✓	✓	✓	✓			
ESC x	Select near-letter quality or draft	✓	✓	✓	✓	✓	✓	✓	✓	✓	✓	✓	✓	✓	✓
* DEL	Delete last character in buffer	✓	✓	✓	✓	✓	✓	✓	✓	✓	✓	✓	✓	✓	✓

* Nonrecommended or deleted command

9-Pin Printers

		1985					1984					1983					
		S	S	S	S	S	S	S	S	S	S	S	S	S	S		
S: Standard model N: NLSP model		HS-80	FX-286	FX-85	FX-185	P-80	RX-80 F/T+	RX-100	LX-80	FX-80+	FX-100+	JX-80	RX-80	RX-80 F/T	RX-100	FX-80	FX-100
ESC g	Select 15-cpi																
ESC l	Select immediate print mode		✓	✓	✓							✓				✓	✓
* ESC j	Reverse paper feed		✓	✓	✓							✓				✓	✓
ESC k	Select typeface																
	0 Roman																
	1 Sans serif																
ESC l	Set left margin	✓	✓	✓	✓		✓	✓	✓	✓	✓	✓	✓	✓	✓	✓	✓
ESC m	Select printing of upper control codes						✓	✓	✓				✓	✓	✓		
ESC p	Turn proportional mode on/off		✓	✓	✓				✓	✓	✓	✓				✓	✓
ESC r	Select printing color											✓					
* ESC s	Select low-speed mode	✓	✓	✓		✓	✓	✓	✓	✓		✓	✓	✓	✓	✓	✓
ESC t	Select character table																
	0 Table 0 Italic																
	1 Table 1 Graphics																
ESC w	Turn double-height printing on/off																
ESC x	Select near-letter quality or draft	✓	✓	✓	✓												
* DEL	Delete last character in buffer						✓	✓	✓	✓	✓	✓	✓	✓	✓	✓	✓
		Not supported in the Command Summary or Recommended Operations sections															

* Nonrecommended or deleted command

Feature Summary

24/48-Pin Printers..... F-3

9-Pin Printers F-78

This section lists the features and options of all dot-matrix printers made by EPSON for the American, European, and Pacific markets (excluding Japan). Listed first are 24/48-pin printers followed by 9-pin printers.

Please note the following:

The year listed under “Year introduced” is approximate; models debut at different times in different countries.

Even though the market region is listed as America, Europe, or Pacific, not all countries in those regions may market that particular printer.

The same model name may appear several times because the features or commands available on that printer changed from approximately the date listed.

The last digit of some option model numbers varies depending on where the option is sold; however, the option itself is the same no matter where it is purchased.

The buffer size is adjustable by DIP switch or SelecType on many printers. Always make sure the buffer is set to the highest size before defining user-defined (download) characters.

24/48-Pin Printers

ActionPrinter L-750

Year introduced: 1989

Market: America

Built-in features

Print method	24-pin impact
Speed	LQ 60 cps @ 10 cpi 72 cps @ 12 cpi
	Draft 180 cps @ 10 cpi 216 cps @ 12 cpi
Print width	8 inches
Paper types	Continuous, Single sheets
Multipart forms	Original plus 2 copies
Paper paths	Rear, Top
Tractor	Pull
Paper parking	Not available
Buffer size	8KB or 1KB
Interface	Parallel
Fonts (typefaces)	Roman, Sans Serif

Options (with model numbers)

Cut-sheet feeder	#7341 (Single-bin)
Interfaces	#8148, #8165, #8172
Ribbon	#7753 (Fabric)

ActionPrinter L-750 DIP-switch settings

Country	U.S.	France	Germany	U.K.	Denmark	Sweden	Italy	Spain
1-1	ON	ON	ON	ON	OFF	OFF	OFF	OFF
1-2	ON	ON	OFF	OFF	ON	ON	OFF	OFF
1-3	ON	OFF	ON	OFF	ON	OFF	ON	OFF

Font	Draft	Sans Serif	Not used	Roman
1-4	ON	ON	OFF	OFF
1-5	ON	OFF	ON	OFF

	ON	OFF
1-6	Condensed printing	Noncondensed printing
1-7	Graphics character table	Italics character table
1-8	Cut-sheet feeder mode on	Cut-sheet feeder mode off
2-1	12-inch page length	11-inch page length
2-2	Cut-sheet feeder page length 65 lines	Cut-sheet feeder page length 61 lines
2-3	1-inch skip-over-perforation	No skip-over-perforation
2-4	CR command produces a line feed	CR command does not produce a line feed
2-5	8-KB buffer	1-KB buffer
2-6	Bidirectional printing possible	Unidirectional printing only

Pitch	Proportional	12 cpi	15 cpi	10 cpi
2-7	ON	ON	OFF	OFF
2-8	ON	OFF	ON	OFF

Built-in features

Print method	24-pin impact
Speed	LQ 50 cps @ 10 cpi 60 cps @ 12 cpi Draft 150 cps @ 10 cpi 180 cps @ 12 cpi
Print width	8 inches
Paper types	Continuous, Single sheets
Multipart forms	Original plus 2 copies
Paper paths	Rear, Top
Tractor	Pull
Paper parking	Not available
Buffer size	8KB or 1KB
Interface	Parallel
Fonts (typefaces)	Roman, Sans Serif

Options (with model numbers)

Cut-sheet feeder	#7341 (Single-bin)
Interfaces	#8143, #8145, #8148, #8149, #8149M, #8161, #8165, #8172, #8172M
Ribbon	#7753 (Fabric)
Font cartridges	#7400, #7401, #7402, #7403, #7407

ActionPrinter L-1000 DIP-switch settings

Country	U.S.	France	Germany	U.K.	Denmark	Sweden	Italy	Spain
1-1	ON	ON	ON	ON	OFF	OFF	OFF	OFF
1-2	ON	ON	OFF	OFF	ON	ON	OFF	OFF
1-3	ON	OFF	ON	OFF	ON	OFF	ON	OFF

Font	Draft	Sans Serif	Font Cartridge	Roman
1-4	ON	ON	OFF	OFF
1-5	ON	OFF	ON	OFF

	ON	OFF
1-6	Condensed printing	Noncondensed printing
1-7	Graphics character table	Italics character table
1-8	Cut-sheet feeder mode on	Cut-sheet feeder mode off
2-1	12-inch page length	11-inch page length
2-2	Cut-sheet feeder page length 65 lines	Cut-sheet feeder page length 61 lines
2-3	1-inch skip-over-perforation	No skip-over-perforation
2-4	CR command produces a line feed	CR command does not produce a line feed
2-5	8-KB buffer	1-KB buffer
2-6	Bidirectional printing possible	Unidirectional printing only

Pitch	Proportional	12 cpi	15 cpi	10 cpi
2-7	ON	ON	OFF	OFF
2-8	ON	OFF	ON	OFF

Built-in features

Print method	24-pin impact
Speed	LQ 53 cps @ 10 cpi 64 cps @ 12 cpi Draft 160 cps @ 10 cpi 192 cps @ 12 cpi
Print width	8 inches
Paper types	Continuous, Single sheets, Labels
Multipart forms	Original plus 2 copies
Paper paths	Rear, Top, Bottom
Tractor	Pull
Paper parking	Not available
Buffer size	8KB or 1KB
Interface	Parallel
Fonts (typefaces)	Roman, Sans Serif, Courier, Prestige, Script, OCR B, Orator

Options (with model numbers)

Cut-sheet feeder	#7341 (Single-bin)
Interfaces	#8143, #8148, #8165
Ribbons	#7753 (Fabric), #7768 (Film)

ActionPrinter 3000 DIP-switch settings

Country (1-7 OFF)	U.S.	France	Germany	U.K.	Denmark	Sweden	Italy	Spain
1-1	ON	ON	ON	ON	OFF	OFF	OFF	OFF
1-2	ON	ON	OFF	OFF	ON	ON	OFF	OFF
1-3	ON	OFF	ON	OFF	ON	OFF	ON	OFF

Character table (1-7 ON)	PC437	PC850	PC860	PC863	PC865
1-1	ON	ON	ON	ON	OFF
1-2	ON	ON	OFF	OFF	ON
1-3	ON	OFF	ON	OFF	ON

Font	Draft	Prest.	OCR-B	Roman	Orator	S.Serif	Scr.	Cour.
1-4	ON	ON	ON	ON	OFF	OFF	OFF	OFF
1-5	ON	ON	OFF	OFF	ON	ON	OFF	OFF
1-6	ON	OFF	ON	OFF	ON	OFF	ON	OFF

	ON			OFF		
1-7	Graphics character tables			Italics character table		
1-8	Cut-sheet feeder mode on			Cut-sheet feeder mode off		

Paper length (1-8 ON)	65 lines (letter size)			61 lines (A4)		
2-1	ON	ON	OFF	OFF	OFF	OFF
2-2	ON	OFF	ON	ON	OFF	OFF

Paper length (1-8 OFF)	11.7 inches	12 inches	8.5 inches	11 inches
2-1	ON	ON	OFF	OFF
2-2	ON	OFF	ON	OFF

	ON			OFF		
2-3	CR command produces a line feed			CR command does not produce a line feed		
2-4	8-KB buffer			1-KB buffer		
2-5	Bidirectional printing possible			Unidirectional printing only		
2-6	1-inch skip-over-perforation			No skip-over-perforation		

Pitch	20 cpi	12 cpi	17 cpi	10 cpi
2-7	ON	ON	OFF	OFF
2-8	ON	OFF	ON	OFF

ActionPrinter 3250

Year introduced: 1991

Market: America

Built-in features

Print method	24-pin impact
Speed	LQ 60 cps @ 10 cpi 72 cps @ 12 cpi Draft 167 cps @ 10 cpi 200 cps @ 12 cpi
Print width	8 inches
Paper types	Continuous, Single sheets, Envelopes, Labels
Multipart forms	Original plus 1 copy
Paper paths	Rear, Front
Tractor	Push
Paper parking	Available
Buffer size	11KB or 1.75KB
Interface	Parallel
Fonts (typefaces)	Roman, Sans Serif, Courier, Prestige, Script

Options (with model numbers)

Tractor	C800262 (Push)
Ribbon	S015032 (Fabric)

ActionPrinter 3250 default-setting mode

This printer has no DIP switches; however, the following settings can be made in a special default-setting mode.

Setting	Options
Character table	PC437, PC850, PC860, PC863, PC865
Page length (for continuous paper)	11, 12, 8.5, or 70/6 (A4) inches
Skip-over-perforation	On or Off
Tear-off position	On or Above tear-off edge
Top-of-form position	-3, -2, -1, ± 0 , 1, 2, 3
Graphics printing direction	Unidirectional or Bidirectional
Download character memory	On or Off
Auto line feed	On or Off
Hex dump/demonstration	Hex dump mode or Demonstration printout

Built-in features

Print method	24-pin impact
Speed	LQ 66 cps @ 10 cpi 79 cps @ 12 cpi Draft 180 cps @ 10 cpi 216 cps @ 12 cpi
Print width	8 inches
Paper types	Continuous, Single sheets, Envelopes, Labels
Multipart forms	Original plus 1 copy
Paper paths	Rear, Front
Tractor	Push
Paper parking	Available
Buffer size	11KB, 1.75KB
Interface	Parallel
Fonts (typefaces)	Roman, Sans Serif, Courier, Prestige, Script
Nonprintable area	5.3 mm at the top of single sheets

Options (with model numbers)

Color upgrade kit	C83201*
Tractor	C80026* (Pull)
Ribbon	S015060 (Fabric), S015061 (Color)

*The last digit of the option model numbers shown above as an asterisk varies by country.

ActionPrinter 3260 default-setting mode

This printer has no DIP switches; however, the following settings can be made in a special default-setting mode.

Setting	Options
Character table	PC437, PC850, PC860, PC863, PC865, PC861, BRASCII, Abicom, Italic
Page length (for continuous paper)	8.5, 11, 12, or 70/6 (A4) inches
Skip-over-perforation	On or Off
Tear-off position	On or Above cutter
Graphic print direction	Unidirectional or Bidirectional
TOF position	-3, -2, -1, ±0, 1, 2, 3
Download	On or Off
Auto line feed	On or Off
Hex dump/Demonstration	Hex dump or Demonstration

Built-in features

Print method	24-pin impact
Speed	LQ 50 cps @ 10 cpi 60 cps @ 12 cpi Draft 150 cps @ 10 cpi 180 cps @ 12 cpi
Print width	8 inches
Paper types	Continuous, Single sheets, Labels
Multipart forms	Original plus 2 copies
Paper paths	Rear, Top
Tractor	Push
Paper parking	Available
Buffer size	8KB or 1KB
Interface	Parallel
Fonts (typefaces)	Roman, Sans Serif

Options (with model numbers)

Cut-sheet feeder	C806122 (Single-bin)
Tractor	C800062 (Pull)
Interfaces	#8143, #8148, #8165, #8641, #8642
Ribbons	#7753 (Fabric), #7768 (Film)
Font cartridge	#7407

ActionPrinter 4000 DIP-switch settings

Country	U.S.	France	Germany	U.K.	Denmark	Sweden	Italy	Spain
1-1	ON	ON	ON	ON	OFF	OFF	OFF	OFF
1-2	ON	ON	OFF	OFF	ON	ON	OFF	OFF
1-3	ON	OFF	ON	OFF	ON	OFF	ON	OFF

Font	Draft	Sans Serif	Font Cartridge	Roman
1-4	ON	ON	OFF	OFF
1-5	ON	OFF	ON	OFF

	ON	OFF
1-6	Condensed printing	Noncondensed printing
1-7	Graphics character table	Italics character table
1-8	Cut-sheet feeder mode on	Cut-sheet feeder mode off
2-1	12-inch page length	11-inch page length
2-2	Automatic tear-off	No automatic tear-off
2-3	1-inch skip-over-perforation	No skip-over-perforation
2-4	CR command produces a line feed	CR command does not produce a line feed
2-5	8-KB buffer	1-KB buffer
2-6	Bidirectional printing possible	Unidirectional printing only

Pitch	Proportional	12 cpi	15 cpi	10 cpi
2-7	ON	ON	OFF	OFF
2-8	ON	OFF	ON	OFF

Built-in features

Print method	24-pin impact
Speed	LQ 53 cps @ 10 cpi 64 cps @ 12 cpi Draft 160 cps @ 10 cpi 192 cps @ 12 cpi
Print width	8 inches
Paper types	Continuous, Single sheets, Envelopes, Labels
Multipart forms	Original plus 2 copies
Paper paths	Rear, Top
Tractor	Push
Paper parking	Available
Buffer size	8KB or 1KB
Interface	Parallel
Fonts (typefaces)	Roman, Sans Serif, Courier, Prestige, Script, OCR B, OCR A, Orator, Orator S

Options (with model numbers)

Cut-sheet feeder	C806122 (Single-bin)
Tractor	C800062 (Pull)
Interfaces	#8143, #8148, #8165, C823032, C823021
Ribbons	#7753 (Fabric), #7768 (Film)

ActionPrinter 4000 DIP-switch settings

Country (1-7 OFF)	U.S.	France	Germany	U.K.	Denmark	Sweden	Italy	Spain
1-1	ON	ON	ON	ON	OFF	OFF	OFF	OFF
1-2	ON	ON	OFF	OFF	ON	ON	OFF	OFF
1-3	ON	OFF	ON	OFF	ON	OFF	ON	OFF

Character table (1-7 ON)	PC437	PC850	PC860	PC863	PC865
1-1	ON	ON	ON	ON	OFF
1-2	ON	ON	OFF	OFF	ON
1-3	ON	OFF	ON	OFF	ON

Paper length	11.7 inches	12 inches	8.5 inches	11 inches
1-4	ON	ON	OFF	OFF
1-5	ON	OFF	ON	OFF

	ON	OFF
1-6	Condensed printing	Noncondensed printing
1-7	Graphics character tables	Italics character table
1-8	Cut-sheet feeder mode on	Cut-sheet feeder mode off
2-1	Not used	Not used
2-2	Automatic tear-off	No automatic tear-off
2-3	1-inch skip-over-perforation	No skip-over-perforation
2-4	CR command produces a line feed	CR command does not produce a line feed
2-5	8-KB buffer	1-KB buffer
2-6	Bidirectional printing possible	Unidirectional printing only

Pitch	Proportional	12 cpi	15 cpi	10 cpi
2-7	ON	ON	OFF	OFF
2-8	ON	OFF	ON	OFF

Built-in features

Print method	24-pin impact
Speed	LQ 50 cps @ 10 cpi 60 cps @ 12 cpi Draft 150 cps @ 10 cpi 180 cps @ 12 cpi
Print width	13.6 inches
Paper types	Continuous, Single sheets, Envelopes, Labels
Multipart forms	Original plus 2 copies
Paper paths	Rear, Top
Tractor	Push
Paper parking	Available
Buffer size	8KB or 1KB
Interface	Parallel
Fonts (typefaces)	Roman, Sans Serif

Options (with model numbers)

Cut-sheet feeder	C806242 (Single-bin)
Tractor	C800142 (Pull)
Interfaces	#8143, #8148, #8165, #8172
Ribbons	#7754 (Fabric), #7770 (Film)
Font cartridge	#7407

ActionPrinter 4500 DIP-switch settings

Country	U.S.	France	Germany	U.K.	Denmark	Sweden	Italy	Spain
1-1	ON	ON	ON	ON	OFF	OFF	OFF	OFF
1-2	ON	ON	OFF	OFF	ON	ON	OFF	OFF
1-3	ON	OFF	ON	OFF	ON	OFF	ON	OFF

Font	Draft	Sans Serif	Font Cartridge	Roman
1-4	ON	ON	OFF	OFF
1-5	ON	OFF	ON	OFF

	ON	OFF
1-6	Condensed printing	Noncondensed printing
1-7	Graphics character table	Italics character table
1-8	Cut-sheet feeder mode on	Cut-sheet feeder mode off
2-1	12-inch page length	11-inch page length
2-2	Automatic tear-off	No automatic tear-off
2-3	1-inch skip-over-perforation	No skip-over-perforation
2-4	CR command produces a line feed	CR command does not produce a line feed
2-5	8-KB buffer	1-KB buffer
2-6	Bidirectional printing possible	Unidirectional printing only

Pitch	Proportional	12 cpi	15 cpi	10 cpi
2-7	ON	ON	OFF	OFF
2-8	ON	OFF	ON	OFF

Built-in features

Print method	24-pin impact
Speed	LQ 53 cps @ 10 cpi 64 cps @ 12 cpi Draft 160 cps @ 10 cpi 192 cps @ 12 cpi
Print width	13.6 inches
Paper types	Continuous, Single sheets, Envelopes, Labels
Multipart forms	Original plus 2 copies
Paper paths	Rear, Top
Tractor	Push
Paper parking	Available
Buffer size	8KB or 1KB
Interface	Parallel
Fonts (typefaces)	Roman, Sans Serif, Courier, Prestige, Script, OCR B, OCR A, Orator, Orator S

Options (with model numbers)

Cut-sheet feeder	C806242 (Single-bin)
Tractor	C800142 (Pull)
Interfaces	#8143, #8148, #8165, C823032, C823021
Ribbons	#7754 (Fabric), #7770 (Film)

ActionPrinter 4500 DIP-switch settings

Country (1-7 OFF)	U.S.	France	Germany	U.K.	Denmark	Sweden	Italy	Spain
1-1	ON	ON	ON	ON	OFF	OFF	OFF	OFF
1-2	ON	ON	OFF	OFF	ON	ON	OFF	OFF
1-3	ON	OFF	ON	OFF	ON	OFF	ON	OFF

Character table (1-7 ON)	PC437	PC850	PC860	PC863	PC865
1-1	ON	ON	ON	ON	OFF
1-2	ON	ON	OFF	OFF	ON
1-3	ON	OFF	ON	OFF	ON

Paper length	11.7 inches	12 inches	8.5 inches	11 inches
1-4	ON	ON	OFF	OFF
1-5	ON	OFF	ON	OFF

	ON	OFF
1-6	Condensed printing	Noncondensed printing
1-7	Graphics character tables	Italics character table
1-8	Cut-sheet feeder mode on	Cut-sheet feeder mode off
2-1	Not used	Not used
2-2	Automatic tear-off	No automatic tear-off
2-3	1-inch skip-over-perforation	No skip-over-perforation
2-4	CR command produces a line feed	CR command does not produce a line feed
2-5	8-KB buffer	1-KB buffer
2-6	Bidirectional printing possible	Unidirectional printing only

Pitch	Proportional	12 cpi	15 cpi	10 cpi
2-7	ON	ON	OFF	OFF
2-8	ON	OFF	ON	OFF

ActionPrinter 5000

Year introduced: 1991

Market: America

Built-in features

Print method	24-pin impact
Speed	LQ 70 cps @ 10 cpi 84 cps @ 12 cpi Draft 210 cps @ 10 cpi 252 cps @ 12 cpi High-speed draft 225 cps @ 10 cpi
Print width	8 inches
Paper types	Continuous, Single sheets, Envelopes, Labels
Multipart forms	Original plus 3 copies
Paper paths	Rear, Top, Bottom, Front
Tractors	Push, Pull
Paper parking	Available
Buffer size	8KB
Interface	Parallel
Fonts (typefaces)	Roman, Sans Serif, Courier, Prestige, Script, OCR B, Orator, Orator S, Script C

Options (with model numbers)

Cut-sheet feeders	C806372, C806382 (Single-bin)
Tractor	C800192 (Pull)
Interfaces	C823061, C823081, C806382
Ribbons	#7753 (Fabric), #7768 (Film)

ActionPrinter 5000 DIP-switch settings

Country (1-4 OFF)	U.S.	France	Germany	U.K.	Denmark	Sweden	Italy	Spain
1-1	ON	ON	ON	ON	OFF	OFF	OFF	OFF
1-2	ON	ON	OFF	OFF	ON	ON	OFF	OFF
1-3	ON	OFF	ON	OFF	ON	OFF	ON	OFF

Character table (1-4 ON)	PC437	PC850	PC860	PC863	PC865
1-1	ON	ON	ON	ON	OFF
1-2	ON	ON	OFF	OFF	ON
1-3	ON	OFF	ON	OFF	ON

	ON	OFF
1-4	Graphics character tables	Italics character table
1-5	Unidirectional printing only	Bidirectional printing possible
1-6	High-speed draft printing	Normal draft printing
1-7	No buffer	8-KB buffer
1-8	1-inch skip-over-perforation	No skip-over-perforation

Paper length	11.7 inches	12 inches	8.5 inches	11 inches
2-1	ON	ON	OFF	OFF
2-2	ON	OFF	ON	OFF

	ON	OFF
2-3	Automatic tear-off	No automatic tear-off
2-4	CR command produces a line feed	CR does not cause a line feed

Built-in features

Print method	24-pin impact
Speed	LQ 75 cps @ 10 cpi 90 cps @ 12 cpi Draft 225 cps @ 10 cpi 269 cps @ 12 cpi
Print width	8 inches
Paper types	Continuous, Single sheets, Envelopes, Labels
Multipart forms	Original plus 3 copies
Paper paths	Rear, Top, Bottom, Front
Tractors	Push, Pull
Paper parking	Available
Buffer size	0, 8KB
Interface	Parallel
Fonts (typefaces)	Roman, Sans Serif, Courier, Prestige, Script, OCR B, Orator, Orator-S, Script C, Roman T, Sans Serif H
Nonprintable area	5.3 mm at the top of single sheets

Options (with model numbers)

Cut-sheet feeders	C80637* (Single-bin), C80638* (High-capacity)
Tractor	C80019* (Pull)
Interfaces	C82305*, C82307*, C82310*
Ribbons	#7753 (Fabric), #7768 (Film)

*The last digit of the option model numbers shown above as an asterisk varies by country.

ActionPrinter 5000+ DIP-switch settings

Country (1-4 OFF)	U.S.	France	Germany	U.K.	Denmark I	Sweden	Italy	Spain I
1-1	ON	ON	ON	ON	OFF	OFF	OFF	OFF
1-2	ON	ON	OFF	OFF	ON	ON	OFF	OFF
1-3	ON	OFF	ON	OFF	ON	OFF	ON	OFF

Character table (1-4 ON)	PC437	PC850	PC860	PC863	PC865	BRASCI I	Abicomp
1-1	ON	ON	ON	ON	OFF	OFF	OFF
1-2	ON	ON	OFF	OFF	ON	ON	OFF
1-3	ON	OFF	ON	OFF	ON	OFF	ON

	ON	OFF
1-4	Graphics character tables	Italics character table
1-5	Unidirectional printing only	Bidirectional printing possible
1-6	No function	
1-7	No buffer	8-KB buffer
1-8	1-inch skip-over-perforation	No skip-over-perforation

Paper length	11.7 inches	12 inches	8.5 inches	11 inches
2-1	ON	ON	OFF	OFF
2-2	ON	OFF	ON	OFF

	ON	OFF
2-3	Automatic tear-off	No automatic tear-off
2-4	Auto line feed	No auto line feed

Built-in features

Print method	24-pin impact
Speed	LQ 70 cps @ 10 cpi 84 cps @ 12 cpi Draft 210 cps @ 10 cpi 252 cps @ 12 cpi High-speed draft 225 cps @ 10 cpi
Print width	13.6 inches
Paper types	Continuous, Single sheets, Envelopes, Labels
Multipart forms	Original plus 3 copies
Paper paths	Rear, Top, Bottom, Front
Tractors	Push, Pull
Paper parking	Available
Buffer size	8KB
Interface	Parallel
Fonts (typefaces)	Roman, Sans Serif, Courier, Prestige, Script, OCR B, Orator, Orator S, Script C

Options (with model numbers)

Cut-sheet feeders	C80639*, C80640* (Single-bin)
Tractor	C80022* (Pull)
Interfaces	C82305*, C82306*, C82307*, C82308*
Ribbons	#7754 (Fabric), #7770 (Film)

*The last digit of the option model numbers shown above as an asterisk varies by country.

ActionPrinter 5500 DIP-switch settings

Country (1-4 OFF)	U.S.	France	Germany	U.K.	Denmark	Sweden	Italy	Spain
1-1	ON	ON	ON	ON	OFF	OFF	OFF	OFF
1-2	ON	ON	OFF	OFF	ON	ON	OFF	OFF
1-3	ON	OFF	ON	OFF	ON	OFF	ON	OFF

Character table (1-4 ON)	PC437	PC850	PC860	PC863	PC865
1-1	ON	ON	ON	ON	OFF
1-2	ON	ON	OFF	OFF	ON
1-3	ON	OFF	ON	OFF	ON

	ON	OFF
1-4	Graphics character tables	Italics character table
1-5	Unidirectional printing only	Bidirectional printing possible
1-6	High-speed draft printing	Normal draft printing
1-7	No buffer	8-KB buffer
1-8	1-inch skip-over-perforation	No skip-over-perforation

Paper length	11.7 inches	12 inches	8.5 inches	11 inches
2-1	ON	ON	OFF	OFF
2-2	ON	OFF	ON	OFF

	ON	OFF
2-3	Automatic tear-off	No automatic tear-off
2-4	CR command produces a line feed	CR command does not produce a line feed

Built-in features

Print method	24-pin impact
Speed	LQ 75 cps @ 10 cpi 90 cps @ 12 cpi Draft 225 cps @ 10 cpi 270 cps @ 12 cpi
Print width	13.6 inches
Paper types	Continuous, Single sheets, Envelopes, Labels
Multipart forms	Original plus 5 copies
Paper paths	Rear, Top, Front
Tractor	Push
Paper parking	Available
Buffer size	8KB
Interfaces	Parallel, Serial
Fonts (typefaces)	Roman, Sans Serif, Courier, Prestige, Script, OCR B, OCR A, Orator, Orator S

Options (with model numbers)

Cut-sheet feeder	C806301 (Single-bin)
Ribbons	S015013 (Fabric), #7764 (Film), #7763 (Color)

DLQ-2000 DIP-switch settings

Country	U.S.	France	Germany	U.K.	Denmark	Sweden	Italy	Spain
1-1	ON	ON	ON	ON	OFF	OFF	OFF	OFF
1-2	ON	ON	OFF	OFF	ON	ON	OFF	OFF
1-3	ON	OFF	ON	OFF	ON	OFF	ON	OFF
	ON				OFF			
1-4	Graphics character table				Italics character table			
1-5	Bidirectional printing possible				Unidirectional printing only			
1-6	Color/film ribbon				Ribbon (Fabric)			
1-7	Automatic tear-off				No automatic tear-off			
1-8	1-inch skip-over-perforation				No skip-over-perforation			
Paper length	11.7 inches		12 inches		8.5 inches		11 inches	
2-1	ON		ON		OFF		OFF	
2-2	ON		OFF		ON		OFF	
Interface	Parallel		Serial (even)		Serial (odd)		Serial (none)	
2-3	ON		ON		OFF		OFF	
2-4	ON		OFF		ON		OFF	
Baud	300		19,200		1,200		9,600	
2-5	ON		ON		OFF		OFF	
2-6	ON		OFF		ON		OFF	
	ON				OFF			
2-7	XON/XOFF protocol				DTR protocol			
2-8	CR command produces a line feed				CR command does not produce a line feed			

Built-in features

Print method	24-pin impact
Speed	LQ 120 cps @ 10 cpi 144 cps @ 12 cpi Draft 360 cps @ 10 cpi 432 cps @ 12 cpi High-speed draft 444 cps @ 10 cpi
Print width	13.6 inches
Paper types	Continuous, Single sheets, Envelopes, Labels
Multipart forms	Original plus 5 copies
Paper paths	Rear, Top, Front
Tractor	Push
Paper parking	Available
Buffer size	128KB
Interfaces	Parallel, Serial
Fonts (typefaces)	Roman, Sans Serif, Courier, Prestige, Script, Script C, Orator, Orator S, OCR B, Roman T, Sans Serif H
Nonprintable area	4.2 mm at the top of single sheets

Options (with model numbers)

Cut-sheet feeder	C80630* (Single-bin)
Interfaces	C82307*, C82308*, C82310*, C82312*, C82313*, C82314*, C82315*
Ribbons	S015066 (Fabric), S015608 (Film), S015067 (Color)

*The last digit of the option model numbers shown above as an asterisk varies by country.

DLQ-3000 SelecType settings

This printer has no DIP switches; however, the following settings can be made with SelecType.

SelecType Level 1 Features	Options
Character table	Italic, PC437, PC437 Greek*, PC850, PC852*, PC853*, PC855*, PC857*, PC860, PC861, PC863, PC864*, PC865, PC866*, PC869*, ISO Latin 1T*, ISO 8859-7*, MAZOWIA*, Code MJK*, Bulgaria*, BRASCI, Abicomp
Page tractor	8.5 inches, 11 inches, 12 inches, 70/6 (A4) inches, or Other (24 to 132 lines)
Page CSF	A4, Letter, or Other (24 to 132 lines)
Line spacing	1/6 inch or 1/8 inch
T-margin tractor, T-margin manual, or T-margin CSF	0.2, 0.33, or 1 inch, in 1/180-inch increments
Left margin	0 to 80 columns
Right margin	1 to 136 columns
B-margin tractor	0 to 1 inch, in 1/180-inch increments
Graphics printing direction	Bidirectional or Unidirectional

*Availability varies by country.

SelecType Level 2 Features	Options
Language	English, French, German, Italian, or Spanish
Software	ESC/P 2 or IBM XL24E
Interface	Auto Selection, Parallel, RS-232C, or Optional Slot
I/F timeout	1, 10, or 256 sec.
Input buffer	On or Off
Baud rate	300, 600, 1,200, 2,400, 4,800, 9,600, or 19,200 bps
Parity	None, Even, Odd, or Ignore
Auto tear off	On or Off
Auto LF	On or Off
Auto CR	On or Off †
AGM (Alternate Graphics Mode)	On or Off †
Copy mode	Copy 1 or Copy 2
Standard setting (Default settings)	—

† This setting is available only in IBM mode.

Built-in features

Print method	24-pin impact
Speed	LQ 120 cps @ 10 cpi 144 cps @ 12 cpi Draft 360 cps @ 10 cpi 432 cps @ 12 cpi High-speed draft 444 cps @ 10 cpi
Print width	13.6 inches
Paper types	Continuous, Single sheets, Envelopes, Labels
Multipart forms	Original plus 5 copies
Paper paths	Rear, Top, Front
Tractor	Push
Paper parking	Available
Buffer size	128KB
Interfaces	Parallel, Serial
Fonts (typefaces)	Roman, Sans Serif, Courier, Prestige, Script, Script C, Orator, Orator S, OCR B, Roman T, Sans Serif H
Bar codes	EAN-13, EAN-8, Interleaved 2 of 5, UPC-A, UPC-E, Code 39, Code 128, POSTNET
Nonprintable area	4.2 mm at the top and bottom of single sheets

Options (with model numbers)

Cut-sheet feeder	
Interfaces	C82315*, C82331* S015066 (Fabric), S015608 (Film), S015067 (Color)

DLQ-3000 ('96 ~) SelecType settings

SelectType Level 1 Features	Options
Character table	Italic, PC437, PC437 Greek*, PC774*, PC850, PC852*, PC853*, PC855*, PC857*, PC860, PC861, PC863, PC864*, PC865, PC866*, PC866 LAT*, PC869*, ISO Latin1, ISO Latin 1T*, ISO 8859-2*, ISO 8859-7*, MAZOWIA*, Code MJK*, Bulgaria*, BRASCII, Abicomp, Estonia*, Roman 8
Page tractor	8.5 inches, 11 inches, 12 inches, 70/6 (A4) inches, or Other (24 to 132 lines)
Page CSF	A4, Letter, or Other (24 to 132 lines)
Line spacing	1/6 inch or 1/8 inch
T-margin tractor, T-margin manual, or T-margin CSF	0.2 to 1 inch, in 1/180-inch increments
Left margin	0 to 80 columns
Right margin	1 to 136 columns
B-margin tractor	0 to 1 inch, in 1/180-inch increments
Graphics printing direction	Bidirectional or Unidirectional

*Availability varies by country.

SelectType Level 2 Features	Options
Language	English, French, German, Italian, or Spanish
Software	ESC/P 2 or IBM 2391 Plus
Interface	Auto Selection, Parallel, RS-232C, or Optional Slot
I/F timeout	1 to 255 sec.
Input buffer	On or Off
Baud rate	300, 600, 1,200, 2,400, 4,800, 9,600, or 19,200 bps
Parity	None, Even, Odd, or Ignore
Auto tear off	On or Off
Auto LF	On or Off
Auto CR	On or Off †
AGM (Alternate Graphics Mode)	On or Off †
Copy mode	Copy 1 or Copy 2
Standard setting (Default settings)	—

† This setting is available only in IBM mode.

Built-in features

Print method	24-pin impact
Speed	LQ 60 cps @ 10 cpi 72 cps @ 12 cpi Draft 167 cps @ 10 cpi 200 cps @ 12 cpi
Print width	8 inches
Paper types	Continuous, Single sheets, Labels
Multipart forms	Original plus 1 copy
Paper paths	Rear, Front
Tractor	Push
Paper parking	Not available Buffer size 11KB or 1.75KB
Interface	Parallel
Fonts (typefaces)	Roman, Sans Serif, Courier, Prestige, Script

Options (with model numbers)

Tractor	C800262 (Push)
Ribbon	S015032 (Fabric)

LQ-100 default-setting mode

This printer has no DIP switches; however, the following settings can be made in a special default-setting mode.

Setting	Options
Character table	PC437, PC437 Greek*, PC850, PC851*, PC852*, PC853*, PC855*, PC857*, PC860, PC863, PC864*, PC865, PC866*, PC869*, U.S.S.R. GOST*
Page length (for continuous paper)	11, 12, 8.5, or 70/6 (A4) inches
Skip-over-perforation	On or Off
Tear-off position	On or Above tear-off edge
Top-of-form position	-3, -2, -1, ±0, 1, 2, 3
Graphics printing direction	Unidirectional or Bidirectional
Download character memory	On or Off
Auto line feed	On or Off
Hex dump/demonstration	Hex dump mode or Demonstration printout

*Availability varies by country.

Built-in features

Print method	24-pin impact
Speed	LQ 66 cps @ 10 cpi 79 cps @ 12 cpi Draft 180 cps @ 10 cpi 216 cps @ 12 cpi
Print width	8 inches
Paper types	Continuous, Single sheets, Envelopes, Labels
Multipart forms	Original plus 1 copy
Paper paths	Rear, Front
Tractor	Push
Paper parking	Available
Buffer size	11KB, 1.75KB
Interface	Parallel
Fonts (typefaces)	Roman, Sans Serif, Courier, Prestige, Script
Nonprintable area	5.3 mm at the top of single sheets

Options (with model numbers)

Color upgrade kit	C83201*
Tractor	C80026* (Pull)
Ribbon	S015060 (Fabric), S015061 (Color)

*The last digit of the option model numbers shown as an asterisk varies by country.

LQ-150 default-setting mode

This printer has no DIP switches; however, the following settings can be made in a special default-setting mode.

Setting	Options
Character table	PC437, PC850, PC860, PC863, PC865, PC861, BRASCII, Abicom, Italic
Page length (for continuous paper)	8.5, 11, 12, or 70/6 (A4) inches
Skip-over-perforation	On or Off
Tear-off position	On or Above cutter
Graphic print direction	Unidirectional or Bidirectional
TOF position	-3, -2, -1, ±0, 1, 2, 3
Download	On or Off
Auto line feed	On or Off
Hex dump/Demonstration	Hex dump or Demonstration

Built-in features

Print method	24-pin impact
Speed	LQ 53 cps @ 10 cpi 64 cps @ 12 cpi Draft 160 cps @ 10 cpi 192 cps @ 12 cpi
Print width	8 inches
Paper types	Continuous, Single sheets, Labels
Multipart forms	Original plus 2 copies
Paper paths	Rear, Top, Bottom
Tractor	Pull
Paper parking	Not available
Buffer size	8KB or 1KB
Interface	Parallel
Fonts (typefaces)	Roman, Sans Serif, Courier, Prestige, Script, OCR B, Orator

Options (with model numbers)

Cut-sheet feeder	#7341 (Single-bin)
Interfaces	#8143, #8148, #8165
Ribbons	#7753 (Fabric), #7768 (Film)

LQ-200 DIP-switch settings

Country (1-7 OFF)	U.S.	France	Germany	U.K.	Denmark	Sweden	Italy	Spain
1-1	ON	ON	ON	ON	OFF	OFF	OFF	OFF
1-2	ON	ON	OFF	OFF	ON	ON	OFF	OFF
1-3	ON	OFF	ON	OFF	ON	OFF	ON	OFF
Character table (1-7 ON)	PC437	PC850	PC860	PC863	PC865			
1-1	ON	ON	ON	ON	ON	ON	ON	OFF
1-2	ON	ON	ON	OFF	OFF	OFF	ON	ON
1-3	ON	OFF	OFF	ON	OFF	OFF	ON	ON
Font	Draft	Prest.	OCR-B	Roman	Orator	S.Serif	Scr.	Cour.
1-4	ON	ON	ON	ON	OFF	OFF	OFF	OFF
1-5	ON	ON	OFF	OFF	ON	ON	OFF	OFF
1-6	ON	OFF	ON	OFF	ON	OFF	ON	OFF
	ON				OFF			
1-7	Graphics character tables				Italics character table			
1-8	Cut-sheet feeder mode on				Cut-sheet feeder mode off			
Paper length 1-8 ON	65 lines (letter size)				61 lines (A4)			
2-1	ON	ON	ON	OFF	OFF	OFF	OFF	OFF
2-2	ON	ON	OFF	ON	ON	ON	ON	OFF
Paper length 1-8 OFF	11.7 inches		12 inches		8.5 inches		11 inches	
2-1	ON	ON	ON	OFF	OFF	OFF	OFF	OFF
2-2	ON	ON	OFF	ON	ON	ON	ON	OFF
	ON				OFF			
2-3	CR command produces a line feed				CR command does not produce a line feed			
2-4	8-KB buffer				1-KB buffer			
2-5	Bidirectional printing possible				Unidirectional printing only			
2-6	1-inch skip-over-perforation				No skip-over-perforation			
Pitch	20 cpi		12 cpi		17 cpi		10 cpi	
2-7	ON	ON	ON	OFF	OFF	OFF	OFF	OFF
2-8	ON	ON	OFF	ON	ON	ON	ON	OFF

Built-in features

Print method	24-pin impact
Speed	LQ 80 cps @ 10 cpi 96 cps @ 12 cpi Draft 200 cps @ 10 cpi 240 cps @ 12 cpi
Print width	8 inches
Paper types	Continuous, Single sheets, Envelopes, Labels
Multipart forms	Original plus 1 copy
Paper paths	Rear, Front
Tractor	Push
Paper parking	Available
Buffer size	8KB
Download memory	11KB
Interface	Parallel, Serial
Fonts (typefaces)	Roman, Sans Serif, Courier, Prestige, Script

Options (with model numbers)

Color upgrade kit	C83211*
Cut-sheet feeder	C80637*
Tractor	C80030* (Pull)
Ribbon	#7753 (Fabric), #7768 (Film), S015077 (Color)

*The last digit of the option model numbers shown above as an asterisk varies by country.

LQ-300 default-setting mode

This printer has no DIP switches; however, the following settings can be made in a special default-setting mode.

Setting	Options
Character table	PC437, PC850, PC860, PC863, PC865, PC861, BRASCII, Abicomp, PC437 Greek*, PC869*, ISO 8859-7*, PC853*, PC857*, ISO Latin 1T*, PC855*, PC866*, PC852*, MAZOWIA*, Code MJK*, Bulgarian, PC864*, Italic
Page length (for continuous paper)	8.5, 11, 12, or 70/6 (A4) inches
Skip-over-perforation	On or Off
Auto tear off	On or Off
Graphics printing direction	Unidirectional or Bidirectional
Software emulation	ESC/P 2 or IBM XL24E
AGM (Alternate Graphics Mode)	On or Off †
Auto line feed	On or Off
Interface	Auto (10 sec. wait), Auto (30 sec. wait), Parallel, Serial
Bit rate	300, 600, 1,200, 2,400, 4,800, 9,600, 19,200
Parity bit	None, Odd, Even
Data length	7 bit or 8 bit
EXT/ACK	Disable or Enable
State reply	On or Off

*Availability varies by country.

† This setting is available only in IBM mode.

Built-in features

Print method	24-pin impact
Speed	LQ 50 cps @ 10 cpi 60 cps @ 12 cpi Draft 150 cps @ 10 cpi 180 cps @ 12 cpi
Print width	8 inches
Paper types	Continuous, Single sheets
Multipart forms	Original plus 2 copies
Paper paths	Rear, Top
Tractor	Pull
Paper parking	Not available
Buffer size	8KB or 1KB
Interface	Parallel
Fonts (typefaces)	Roman, Sans Serif

Options (with model numbers)

Cut-sheet feeder	#7341 (Single-bin)
Interfaces	#8143, #8145, #8148
Ribbons	#7753 (Fabric), #7768 (Film)
Font cartridges	#7400, #7401, #7402, #7403

LQ-400 DIP-switch settings

Country	U.S.	France	Germany	U.K.	Denmark	Sweden	Italy	Spain
1-1	ON	ON	ON	ON	OFF	OFF	OFF	OFF
1-2	ON	ON	OFF	OFF	ON	ON	OFF	OFF
1-3	ON	OFF	ON	OFF	ON	OFF	ON	OFF

Font	Draft	Sans Serif	Font Cartridge	Roman
1-4	ON	ON	OFF	OFF
1-5	ON	OFF	ON	OFF

	ON	OFF
1-6	Condensed printing	Noncondensed printing
1-7	Graphics character table	Italics character table
1-8	Cut-sheet feeder mode on	Cut-sheet feeder mode off
2-1	12-inch page length	11-inch page length
2-2	Cut-sheet feeder page length 65 lines	Cut-sheet feeder page length 61 lines
2-3	1-inch skip-over-perforation	No skip-over-perforation
2-4	CR command produces a line feed	CR command does not produce a line feed
2-5	8-KB buffer	1-KB buffer
2-6	Bidirectional printing possible	Unidirectional printing only

Pitch	Proportional	12 cpi	15 cpi	10 cpi
2-7	ON	ON	OFF	OFF
2-8	ON	OFF	ON	OFF

Built-in features

Print method	24-pin impact
Speed	LQ 53 cps @ 10 cpi 64 cps @ 12 cpi Draft 160 cps @ 10 cpi 192 cps @ 12 cpi
Print width	8 inches
Paper types	Continuous, Single sheets, Envelopes, Labels
Multipart forms	Original plus 2 copies
Paper paths	Rear, Top
Tractor	Push
Paper parking	Available
Buffer size	8KB or 1KB
Interface	Parallel
Fonts (typefaces)	Roman, Sans Serif, Courier, Prestige, Script, OCR B, OCR A, Orator, Orator S

Options (with model numbers)

Cut-sheet feeder	C806122 (Single-bin)
Tractor	C800062 (Pull)
Interfaces	#8143, #8148, #8165, C823032, C823021
Ribbons	#7753 (Fabric), #7768 (Film)

LQ-450 DIP-switch settings

Country (1-7 OFF)	U.S.	France	Germany	U.K.	Denmark	Sweden	Italy	Spain
1-1	ON	ON	ON	ON	OFF	OFF	OFF	OFF
1-2	ON	ON	OFF	OFF	ON	ON	OFF	OFF
1-3	ON	OFF	ON	OFF	ON	OFF	ON	OFF

Character table (1-7 ON)	PC437	PC850	PC860	PC863	PC865
1-1	ON	ON	ON	ON	OFF
1-2	ON	ON	OFF	OFF	ON
1-3	ON	OFF	ON	OFF	ON

Paper length	11.7 inches	12 inches	8.5 inches	11 inches
1-4	ON	ON	OFF	OFF
1-5	ON	OFF	ON	OFF

	ON	OFF
1-6	Condensed printing	Noncondensed printing
1-7	Graphics character tables	Italics character table
1-8	Cut-sheet feeder mode on	Cut-sheet feeder mode off
2-1	Not used	Not used
2-2	Automatic tear-off	No automatic tear-off
2-3	1-inch skip-over-perforation	No skip-over-perforation
2-4	CR command produces a line feed	CR command does not produce a line feed
2-5	8-KB buffer	1-KB buffer
2-6	Bidirectional printing possible	Unidirectional printing only

Pitch	Proportional	12 cpi	15 cpi	10 cpi
2-7	ON	ON	OFF	OFF
2-8	ON	OFF	ON	OFF

Built-in features

Print method	24-pin impact
Speed	LQ 50 cps @ 10 cpi 60 cps @ 12 cpi Draft 150 cps @ 10 cpi 180 cps @ 12 cpi
Print width	8 inches
Paper types	Continuous, Single sheets
Multipart forms	Original plus 2 copies
Paper paths	Rear, Top
Tractor	Pull
Paper parking	Not available
Buffer size	8KB or 1KB
Interface	Parallel
Fonts (typefaces)	Roman, Sans Serif

Options (with model numbers)

Cut-sheet feeder	#7341 (Single-bin)
Interfaces	#8143, #8145, #8148, #8149, #8149M, #8161, #8165, #8172, #8172M
Ribbons	#7753 (Fabric), #7768 (Film)
Font cartridges	#7400, #7401, #7402, #7403

LQ-500 DIP-switch settings

Country	U.S.	France	Germany	U.K.	Denmark	Sweden	Italy	Spain
1-1	ON	ON	ON	ON	OFF	OFF	OFF	OFF
1-2	ON	ON	OFF	OFF	ON	ON	OFF	OFF
1-3	ON	OFF	ON	OFF	ON	OFF	ON	OFF

Font	Draft	Sans Serif	Font Cartridge	Roman
1-4	ON	ON	OFF	OFF
1-5	ON	OFF	ON	OFF

	ON	OFF
1-6	Condensed printing	Noncondensed printing
1-7	Graphics character table	Italics character table
1-8	Cut-sheet feeder mode on	Cut-sheet feeder mode off
2-1	12-inch page length	11-inch page length
2-2	Cut-sheet feeder page length 65 lines	Cut-sheet feeder page length 61 lines
2-3	1-inch skip-over-perforation	No skip-over-perforation
2-4	CR command produces a line feed	CR command does not produce a line feed
2-5	8-KB buffer	1-KB buffer
2-6	Bidirectional printing possible	Unidirectional printing only

Pitch	Proportional	12 cpi	15 cpi	10 cpi
2-7	ON	ON	OFF	OFF
2-8	ON	OFF	ON	OFF

Built-in features

Print method	24-pin impact
Speed	LQ 50 cps @ 10 cpi 60 cps @ 12 cpi Draft 150 cps @ 10 cpi 180 cps @ 12 cpi
Print width	8 inches
Paper types	Continuous, Single sheets, Envelopes, Labels
Multipart forms	Original plus 2 copies
Paper paths	Rear, Top
Tractor	Push
Paper parking	Available
Buffer size	8KB or 1KB
Interface	Parallel
Fonts (typefaces)	Roman, Sans Serif

Options (with model numbers)

Cut-sheet feeder	C806121 (Single-bin)
Tractor	C800061 (Pull)
Interfaces	#8143, #8148, #8165, #8172
Ribbons	#7753 (Fabric), #7768 (Film)
Font cartridge	#7407

LQ-510 DIP-switch settings

Country	U.S.	France	Germany	U.K.	Denmark	Sweden	Italy	Spain
1-1	ON	ON	ON	ON	OFF	OFF	OFF	OFF
1-2	ON	ON	OFF	OFF	ON	ON	OFF	OFF
1-3	ON	OFF	ON	OFF	ON	OFF	ON	OFF

Font	Draft	Sans Serif	Font Cartridge	Roman
1-4	ON	ON	OFF	OFF
1-5	ON	OFF	ON	OFF

	ON	OFF
1-6	Condensed printing	Noncondensed printing
1-7	Graphics character table	Italics character table
1-8	Cut-sheet feeder mode on	Cut-sheet feeder mode off
2-1	12-inch page length	11-inch page length
2-2	Automatic tear-off	No automatic tear-off
2-3	1-inch skip-over-perforation	No skip-over-perforation
2-4	CR command produces a line feed	CR command does not produce a line feed
2-5	8-KB buffer	1-KB buffer
2-6	Bidirectional printing possible	Unidirectional printing only

Pitch	Proportional	12 cpi	15 cpi	10 cpi
2-7	ON	ON	OFF	OFF
2-8	ON	OFF	ON	OFF

Built-in features

Print method	24-pin impact
Speed	LQ 53 cps @ 10 cpi 64 cps @ 12 cpi Draft 160 cps @ 10 cpi 192 cps @ 12 cpi
Print width	8 inches
Paper types	Continuous, Single sheets, Envelopes, Labels
Multipart forms	Original plus 2 copies
Paper paths	Rear, Top
Tractor	Push
Paper parking	Available
Buffer size	8KB or 1KB
Interface	Parallel
Fonts (typefaces)	Roman, Sans Serif, Courier, Prestige, Script, OCR B, OCR A, Orator, Orator S

Options (with model numbers)

Cut-sheet feeder	C806122 (Single-bin)
Tractor	C800062 (Pull)
Interfaces	#8143, #8148, #8165, C823032, C823021
Ribbons	#7753 (Fabric), #7768 (Film)

LQ-510 DIP-switch settings

Country (1-7 OFF)	U.S.	France	Germany	U.K.	Denmark	Sweden	Italy	Spain
1-1	ON	ON	ON	ON	OFF	OFF	OFF	OFF
1-2	ON	ON	OFF	OFF	ON	ON	OFF	OFF
1-3	ON	OFF	ON	OFF	ON	OFF	ON	OFF

Character table (1-7 ON)	PC437	PC850	PC860	PC863	PC865
1-1	ON	ON	ON	ON	OFF
1-2	ON	ON	OFF	OFF	ON
1-3	ON	OFF	ON	OFF	ON

Paper length	11.7 inches	12 inches	8.5 inches	11 inches
1-4	ON	ON	OFF	OFF
1-5	ON	OFF	ON	OFF

	ON	OFF
1-6	Condensed printing	Noncondensed printing
1-7	Graphics character tables	Italics character table
1-8	Cut-sheet feeder mode on	Cut-sheet feeder mode off
2-1	Not used	Not used
2-2	Automatic tear-off	No automatic tear-off
2-3	1-inch skip-over-perforation	No skip-over-perforation
2-4	CR command produces a line feed	CR command does not produce a line feed
2-5	8-KB buffer	1-KB buffer
2-6	Bidirectional printing possible	Unidirectional printing only

Pitch	Proportional	12 cpi	15 cpi	10 cpi
2-7	ON	ON	OFF	OFF
2-8	ON	OFF	ON	OFF

Built-in features

Print method	24-pin impact
Speed	LQ 50 cps @ 10 cpi 60 cps @ 12 cpi Draft 150 cps @ 10 cpi 180 cps @ 12 cpi
Print width	8 inches
Paper types	Continuous, Single sheets, Labels
Multipart forms	Original plus 2 copies
Paper paths	Rear, Top
Tractor	Push
Paper parking	Available
Buffer size	8KB or 1KB
Interface	Parallel
Fonts (typefaces)	Roman, Sans Serif

Options (with model numbers)

Cut-sheet feeder	C806122 (Single-bin)
Tractor	C800062 (Pull)
Interfaces	#8143, #8148, #8165, #8641, #8642
Ribbons	#7753 (Fabric), #7768 (Film)
Font cartridge	#7407

LQ-550 DIP-switch settings

Country	U.S.	France	Germany	U.K.	Denmark	Sweden	Italy	Spain
1-1	ON	ON	ON	ON	OFF	OFF	OFF	OFF
1-2	ON	ON	OFF	OFF	ON	ON	OFF	OFF
1-3	ON	OFF	ON	OFF	ON	OFF	ON	OFF

Font	Draft	Sans Serif	Font Cartridge	Roman
1-4	ON	ON	OFF	OFF
1-5	ON	OFF	ON	OFF

	ON	OFF
1-6	Condensed printing	Noncondensed printing
1-7	Graphics character table	Italics character table
1-8	Cut-sheet feeder mode on	Cut-sheet feeder mode off
2-1	12-inch page length	11-inch page length
2-2	Automatic tear-off	No automatic tear-off
2-3	1-inch skip-over-perforation	No skip-over-perforation
2-4	CR command produces a line feed	CR command does not produce a line feed
2-5	8-KB buffer	1-KB buffer
2-6	Bidirectional printing possible	Unidirectional printing only

Pitch	Proportional	12 cpi	15 cpi	10 cpi
2-7	ON	ON	OFF	OFF
2-8	ON	OFF	ON	OFF

Built-in features

Print method	24-pin impact
Speed	LQ 53 cps @ 10 cpi 64 cps @ 12 cpi Draft 160 cps @ 10 cpi 192 cps @ 12 cpi
Print width	8 inches
Paper types	Continuous, Single sheets, Envelopes, Labels
Multipart forms	Original plus 2 copies
Paper paths	Rear, Top
Tractor	Push
Paper parking	Available
Buffer size	8KB or 1KB
Interface	Parallel
Fonts (typefaces)	Roman, Sans Serif, Courier, Prestige, Script, OCR B, OCR A, Orator, Orator S

Options (with model numbers)

Cut-sheet feeder	C806122 (Single-bin)
Tractor	C800062 (Pull)
Interfaces	#8143, #8148, #8165, C823032, C823021
Ribbons	#7753 (Fabric), #7768 (Film)

LQ-550 DIP-switch settings

Country (1-7 OFF)	U.S.	France	Germany	U.K.	Denmark	Sweden	Italy	Spain
1-1	ON	ON	ON	ON	OFF	OFF	OFF	OFF
1-2	ON	ON	OFF	OFF	ON	ON	OFF	OFF
1-3	ON	OFF	ON	OFF	ON	OFF	ON	OFF

Character table (1-7 ON)	PC437	PC850	PC860	PC863	PC865
1-1	ON	ON	ON	ON	OFF
1-2	ON	ON	OFF	OFF	ON
1-3	ON	OFF	ON	OFF	ON

Paper length	11.7 inches	12 inches	8.5 inches	11 inches
1-4	ON	ON	OFF	OFF
1-5	ON	OFF	ON	OFF

	ON	OFF
1-6	Condensed printing	Noncondensed printing
1-7	Graphics character tables	Italics character table
1-8	Cut-sheet feeder mode on	Cut-sheet feeder mode off
2-1	Not used	Not used
2-2	Automatic tear-off	No automatic tear-off
2-3	1-inch skip-over-perforation	No skip-over-perforation
2-4	CR command produces a line feed	CR command does not produce a line feed
2-5	8-KB buffer	1-KB buffer
2-6	Bidirectional printing possible	Unidirectional printing only

Pitch	Proportional	12 cpi	15 cpi	10 cpi
2-7	ON	ON	OFF	OFF
2-8	ON	OFF	ON	OFF

Built-in features

Print method	24-pin impact
Speed	LQ 70 cps @ 10 cpi 84 cps @ 12 cpi Draft 210 cps @ 10 cpi 252 cps @ 12 cpi High-speed draft 225 cps @ 10 cpi
Print width	8 inches
Paper types	Continuous, Single sheets, Envelopes, Labels
Multipart forms	Original plus 3 copies
Paper paths	Rear, Top, Bottom, Front
Tractors	Push, Pull
Paper parking	Available
Buffer size	8KB
Interface	Parallel
Fonts (typefaces)	Roman, Sans Serif, Courier, Prestige, Script, OCR B, Orator, Orator S, Script C

Options (with model numbers)

Cut-sheet feeders	C80637*, C80638* (Single-bin)
Tractor	C80019* (Pull)
Interfaces	C82305*, C82307*, C82310*
Ribbons	#7753 (Fabric), #7768 (Film)

*The last digit of the option model numbers shown above as an asterisk varies by country.

LQ-570 DIP-switch settings

Country (1-4 OFF)	U.S.	France	Germany	U.K.	Denmark	Sweden	Italy	Spain
1-1	ON	ON	ON	ON	OFF	OFF	OFF	OFF
1-2	ON	ON	OFF	OFF	ON	ON	OFF	OFF
1-3	ON	OFF	ON	OFF	ON	OFF	ON	OFF

Character table (1-4 ON)	PC437	PC850	PC860	PC863	PC865
1-1	ON	ON	ON	ON	OFF
1-2	ON	ON	OFF	OFF	ON
1-3	ON	OFF	ON	OFF	ON

	ON	OFF
1-4	Graphics character tables	Italics character table
1-5	Unidirectional printing only	Bidirectional printing possible
1-6	High-speed draft printing	Normal draft printing
1-7	No buffer	8-KB buffer
1-8	1-inch skip-over-perforation	No skip-over-perforation

Paper length	11.7 inches	12 inches	8.5 inches	11 inches
2-1	ON	ON	OFF	OFF
2-2	ON	OFF	ON	OFF

	ON	OFF
2-3	Automatic tear-off	No automatic tear-off
2-4	CR command produces a line feed	CR command does not produce a line feed

Built-in features

Print method	24-pin impact
Speed	LQ 75 cps @ 10 cpi 90 cps @ 12 cpi Draft 225 cps @ 10 cpi 269 cps @ 12 cpi
Print width	8 inches
Paper types	Continuous, Single sheets, Envelopes, Labels
Multipart forms	Original plus 3 copies
Paper paths	Rear, Top, Bottom, Front
Tractors	Push, Pull
Paper parking	Available
Buffer size	0, 8KB
Interface	Parallel
Fonts (typefaces)	Roman, Sans Serif, Courier, Prestige, Script, OCR B, Orator, Orator-S, Script C, Roman T, Sans Serif H
Nonprintable area	5.3 mm at the top of single sheets

Options (with model numbers)

Cut-sheet feeders	C80637* (Single-bin), C80638* (High-capacity)
Tractor	C80019* (Pull)
Interfaces	C82305*, C82307*, C82310*
Ribbons	#7753 (Fabric), #7768 (Film)

*The last digit of the option model numbers shown above as an asterisk varies by country.

LQ-570+ DIP-switch settings

Country (1-4 OFF)	U.S.	France	Germany	U.K.	Denmark I	Sweden	Italy	Spain I
1-1	ON	ON	ON	ON	OFF	OFF	OFF	OFF
1-2	ON	ON	OFF	OFF	ON	ON	OFF	OFF
1-3	ON	OFF	ON	OFF	ON	OFF	ON	OFF

Character table (1-4 ON)	PC437	PC850	PC860	PC863	PC865	BRASCII* PC437**	Abicomp* PC853**	PC437* PC852**
1-1	ON	ON	ON	ON	OFF	OFF	OFF	OFF
1-2	ON	ON	OFF	OFF	ON	ON	OFF	OFF
1-3	ON	OFF	ON	OFF	ON	OFF	ON	OFF

*These character tables are not available on the European version.

**These character tables are available only on the European version.

	ON	OFF
1-4	Graphics character tables	Italics character table
1-5	Unidirectional printing only	Bidirectional printing possible
1-6	IBM emulation*	ESC/P 2
1-7	No buffer	8-KB buffer
1-8	1-inch skip-over-perforation	No skip-over-perforation

*DIP switch 1-6 functions only on the European version of this printer.

Paper length	11.7 inches	12 inches	8.5 inches	11 inches
2-1	ON	ON	OFF	OFF
2-2	ON	OFF	ON	OFF
	ON		OFF	
2-3	Automatic tear-off		No automatic tear-off	
2-4	Auto line feed		No auto line feed	

DIP-switch settings for IBM emulation mode

Character table (1-6 ON)	437	850	860	863	865	437 Greek	853	852
1-1	ON	ON	ON	ON	OFF	OFF	OFF	OFF
1-2	ON	ON	OFF	OFF	ON	ON	OFF	OFF
1-3	ON	OFF	ON	OFF	ON	OFF	ON	OFF
	ON				OFF			
1-4	Character set 1				Character set 2			
1-8	Alternate graphics mode on*				Alternate graphics mode off			
2-1	12-inch page length (cont. paper)				11-inch page length (cont. paper)			
2-2	Auto CR enabled				Auto CR disabled			

*With DIP-switch 1-8 ON, ESC 3, ESC A, ESC J, and ESC * function the same as in ESC/P.

Built-in features

Print method	24-pin impact
Speed	LQ 83 cps @ 10 cpi 100 cps @ 12 cpi Draft 250 cps @ 10 cpi 300 cps @ 12 cpi High-speed draft 300 cpi @ 10 cpi
Print width	10.6 inches
Paper types	Continuous, Single sheets, Envelopes, Labels, Cards, Roll paper
Multipart forms	Original plus 4 copies
Paper paths	Rear, Front
Tractors	Push
Paper parking	Available
Buffer size	0, 64KB
Interface	Parallel
Fonts (typefaces)	Roman, Sans Serif, Courier, Prestige, Script, OCR B, Orator, Orator-S, Script C, Roman T, Sans Serif H
Bar codes	EAN-13, EAN-8, Interleaved 2 of 5, UPC-A, UPC-E, Code 39, Code 128, POSTNET
Nonprintable area	0 mm at the top and bottom of single sheets

Options (with model numbers)

Cut-sheet feeders	C80678* (High-capacity), C80679* (Second-bin)
Roll paper holder	#8310
Interfaces	C82305*, C82306*, C82307*, C82308*, C82310*, C82311*, C82312*, C82313*, C82314*, C82315*, C82331*, C82345*, C82346*
Ribbons	S015016

*The last digit of the option model numbers shown above as an asterisk varies by country.

LQ-670 default-setting mode

This printer has no DIP switches; however, the following settings can be made in a special default-setting mode.

Setting	Options
Page length for tractor	3, 3.5, 4, 5.5, 6, 7, 8, 8.5, 11, 70/6, 12, 14, 17, or Others inches
Skip over perforation	On, Off, or Others
Auto tear off	On or Off
Auto line feed	On or Off
Print direction	Auto, Uni-d, or Bi-d
I/F mode	Auto, Parallel, or Option
Auto I/F wait time	10 or 30 sec.
Software	ESC/P 2 or IBM 2390 Plus
Character table	Italic, PC437, PC437 Greek*, PC774*, PC850, PC852*, PC853*, PC855*, PC857*, PC860, PC861, PC863, PC864*, PC865, PC866*, PC866 LAT.*, PC869*, BRASCII, Abicomp, Roman 8, ISO Latin 1, MAZOWIA*, Code MJK*, ISO 8859-2*, ISO 8859-7*, ISO Latin 1T*, Bulgaria*, Estonia*
International character set	U.S.A., France, Germany, U.K., Denmark, Sweden, Italy, Spain
0 slash	0 or Ø
High speed draft	On or Off
Input buffer	On or Off
Buzzer	On or Off
Auto CR	On or Off †
A.G.M.	On or Off †
Font	OCR-B, Orator, Orator-S, Script C, Roman T (PS), Sans Serif H (PS)

* Availability varies by country.

† This setting is available only in IBM mode.

Built-in features

Print method	24-pin impact
Speed	LQ 60 cps @ 10 cpi Draft 180 cps @ 10 cpi
Print width	8 inches
Paper types	Continuous, Single sheets
Multipart forms	Original plus 1 copy
Paper paths	Rear, Top
Paper parking	Not available
Buffer size	7KB or 1KB
Interfaces	Parallel, Serial
Fonts (typefaces)	Roman, Sans Serif
Nonprintable area	22.0 mm at the top of single sheets

Options (with model numbers)

Cut-sheet feeders	#7333 (Single-bin), #8347 (Double-bin)
Tractor	#7303 (Pull)
Interfaces	#8148, #8165, #8172
Ribbons	N/A
Font cartridges	#7400, #7401, #7402, #7403, #7404

LQ-800 DIP-switch settings

Country	U.S.	France	Germany	U.K.	Denmark	Sweden	Italy	Spain
1-1	ON	ON	ON	ON	OFF	OFF	OFF	OFF
1-2	ON	ON	OFF	OFF	ON	ON	OFF	OFF
1-3	ON	OFF	ON	OFF	ON	OFF	ON	OFF
	ON				OFF			
1-4	7-KB buffer				1-KB buffer			
1-5	Draft printing				LQ printing			
1-6	Condensed printing				Noncondensed printing			
1-7	1-inch skip-over-perforation				No skip-over-perforation			
1-8	Cut-sheet feeder mode on				Cut-sheet feeder mode off			
2-1	12-inch page length				11-inch page length			
2-2	Identity module				Internal firmware			
Interface	Serial (none)		Serial (even)		Serial (odd)		Parallel	
2-3	ON		ON		OFF		OFF	
2-4	ON		OFF		ON		OFF	
Baud	9,600		4,800		1,200		300	
2-5	ON		ON		OFF		OFF	
2-6	ON		OFF		ON		OFF	
	ON				OFF			
2-7	SLCT IN on				SLCT IN off			
2-8	CR command produces a line feed				CR command does not produce a line feed			

Built-in features

Print method	24-pin impact
Speed	LQ 73 cps @ 10 cpi 88 cps @ 12 cpi Draft 220 cps @ 10 cpi 264 cps @ 12 cpi
Print width	8 inches
Paper types	Continuous, Single sheets
Multipart forms	Original plus 3 copies
Paper paths	Rear, Top
Tractor	Push
Paper parking	Available
Buffer size	6KB
Interfaces	Parallel, Serial
Fonts (typefaces)	Roman, Sans Serif

Options (with model numbers)

Cut-sheet feeders	#7339 (Single-bin), #7346 (Double-bin)
Tractor	#7311 (Pull)
Interfaces	#8143, #8145, #8148, #8149, #8149(M), #8161, #8165, #8172, #8172(M)
Ribbons	#7753 (Fabric), #7768 (Film)
Font cartridge	#7407

LQ-850 DIP-switch settings

Country	U.S.	France	Germany	U.K.	Denmark	Sweden	Italy	Spain
1-1	ON	ON	ON	ON	OFF	OFF	OFF	OFF
1-2	ON	ON	OFF	OFF	ON	ON	OFF	OFF
1-3	ON	OFF	ON	OFF	ON	OFF	ON	OFF
	ON				OFF			
1-4	Graphics character table				Italics character table			
1-5	Unidirectional printing only				Bidirectional printing possible			
1-6	Not used				Not used			
1-7	Cut-sheet feeder mode on				Cut-sheet feeder mode off			
1-8	No buffer				6-KB buffer			
2-1	12-inch page length				11-inch page length			
2-2	1-inch skip-over-perforation				No skip-over-perforation			
Interface	Serial (none)		Serial (even)		Serial (odd)		Parallel	
2-3	ON		ON		OFF		OFF	
2-4	ON		OFF		ON		OFF	
Baud	300		4,800		1,200		9,600	
2-5	ON		ON		OFF		OFF	
2-6	ON		OFF		ON		OFF	
	ON				OFF			
2-7	Automatic tear-off				No automatic tear-off			
2-8	CR command produces a line feed				CR command does not produce a line feed			

Built-in features

Print method	24-pin impact
Speed	LQ 82 cps @ 10 cpi 98 cps @ 12 cpi Draft 246 cps @ 10 cpi 295 cps @ 12 cpi High-speed draft 300 cps @ 10 cpi
Print width	8 inches
Paper types	Continuous, Single sheets, Envelopes, Labels
Multipart forms	Original plus 3 copies
Paper paths	Rear, Top
Tractor	Push
Paper parking	Available
Buffer size	6KB
Interfaces	Parallel, Serial
Fonts (typefaces)	Roman, Sans Serif, Courier, Prestige, Script, OCR B, OCR A, Orator, Orator S

Options (with model numbers)

Cut-sheet feeders	#7339 (Single-bin), #7346 (Double-bin)
Tractor	#7311 (Pull)
Interfaces	#8143, #8148, #8165, #8641, #8642
Ribbons	#7753 (Fabric), #7768 (Film)

LQ-850 DIP-switch settings

Country (1-4 OFF)	U.S.	France	Germany	U.K.	Denmark	Sweden	Italy	Spain
1-1	ON	ON	ON	ON	OFF	OFF	OFF	OFF
1-2	ON	ON	OFF	OFF	ON	ON	OFF	OFF
1-3	ON	OFF	ON	OFF	ON	OFF	ON	OFF

Character table (1-4 ON)	PC437	PC850	PC860	PC863	PC865
1-1	ON	ON	ON	ON	OFF
1-2	ON	ON	OFF	OFF	ON
1-3	ON	OFF	ON	OFF	ON

	ON	OFF
1-4	Graphics character tables	Italics character table
1-5	Bidirectional printing possible	Unidirectional printing only
1-6	Normal-speed draft	High-speed draft
1-7	Cut-sheet feeder mode on	Cut-sheet feeder mode off
1-8	1-inch skip-over-perforation	No skip-over-perforation

Paper length	11.7 inches	12 inches	8.5 inches	11 inches
2-1	ON	ON	OFF	OFF
2-2	ON	OFF	ON	OFF

Interface	Serial (none)	Serial (even)	Serial (odd)	Parallel
2-3	ON	ON	OFF	OFF
2-4	ON	OFF	ON	OFF

Baud	300	19,200	1,200	9,600
2-5	ON	ON	OFF	OFF
2-6	ON	OFF	ON	OFF

	ON	OFF
2-7	Automatic tear-off	No automatic tear-off
2-8	CR command produces a line feed	CR command does not produce a line feed

Built-in features

Print method	24-pin impact
Speed	LQ 82 cps @ 10 cpi 98 cps @ 12 cpi Draft 246 cps @ 10 cpi 295 cps @ 12 cpi High-speed draft 300 cps @ 10 cpi
Print width	8 inches
Paper types	Continuous, Single sheets, Envelopes, Labels
Multipart forms	Original plus 3 copies
Paper paths	Rear, Top
Tractor	Push
Paper parking	Available
Buffer size	6KB
Interfaces	Parallel, Serial
Fonts (typefaces)	Roman, Sans Serif

Options (with model numbers)

Cut-sheet feeders	#7339 (Single-bin), #7346 (Double-bin)
Tractor	#7311 (Pull)
Interfaces	#8143, #8148, #8165, #8641, #8642
Ribbons	#7753 (Fabric), #7768 (Film)
Font cartridge	#7407

LQ-850+ DIP-switch settings

Country	U.S.	France	Germany	U.K.	Denmark	Sweden	Italy	Spain
1-1	ON	ON	ON	ON	OFF	OFF	OFF	OFF
1-2	ON	ON	OFF	OFF	ON	ON	OFF	OFF
1-3	ON	OFF	ON	OFF	ON	OFF	ON	OFF
	ON				OFF			
1-4	Graphics character table				Italics character table			
1-5	Unidirectional printing only				Bidirectional printing possible			
1-6	Normal draft				High-speed draft			
1-7	Cut-sheet feeder mode on				Cut-sheet feeder mode off			
1-8	No buffer				6-KB buffer			
2-1	12-inch page length				11-inch page length			
2-2	1-inch skip-over-perforation				No skip-over-perforation			
Interface	Serial (none)		Serial (even)		Serial (odd)		Parallel	
2-3	ON		ON		OFF		OFF	
2-4	ON		OFF		ON		OFF	
Baud	300		19,200		1,200		9,600	
2-5	ON		ON		OFF		OFF	
2-6	ON		OFF		ON		OFF	
	ON				OFF			
2-7	Automatic tear-off				No automatic tear-off			
2-8	CR command produces a line feed				CR command does not produce a line feed			

Built-in features

Print method	24-pin impact
Speed	LQ 75 cps @ 10 cpi 90 cps @ 12 cpi Draft 225 cps @ 10 cpi 270 cps @ 12 cpi High-speed draft 300 cps @ 10 cpi
Print width	8 inches
Paper types	Continuous, Single sheets, Envelopes, Labels
Multipart forms	Original plus 3 copies
Paper paths	Rear, Top
Tractor	Push
Paper parking	Available
Buffer size	6KB
Interfaces	Parallel, Serial
Fonts (typefaces)	Roman, Sans Serif

Options (with model numbers)

Cut-sheet feeders	C806141 (Single-bin), C806151 (Double-bin)
Tractor	C800071 (Pull)
Interfaces	#8143, #8148, #8165, #8641, #8642
Ribbons	#7762 (Fabric), #7764 (Film), #7763 (Color)
Font cartridge	#7407

LQ-860 DIP-switch settings

Country	U.S.	France	Germany	U.K.	Denmark	Sweden	Italy	Spain
1-1	ON	ON	ON	ON	OFF	OFF	OFF	OFF
1-2	ON	ON	OFF	OFF	ON	ON	OFF	OFF
1-3	ON	OFF	ON	OFF	ON	OFF	ON	OFF
	ON				OFF			
1-4	Graphics character table				Italics character table			
1-5	Unidirectional printing only				Bidirectional printing possible			
1-6	Normal-speed draft				High-speed draft			
1-7	Cut-sheet feeder mode on				Cut-sheet feeder mode off			
1-8	No buffer				6-KB buffer			
2-1	12-inch page length				11-inch page length			
2-2	1-inch skip-over-perforation				No skip-over-perforation			
Interface	Serial (none)		Serial (even)		Serial (odd)		Parallel	
2-3	ON		ON		OFF		OFF	
2-4	ON		OFF		ON		OFF	
Baud	300		19,200		1,200		9,600	
2-5	ON		ON		OFF		OFF	
2-6	ON		OFF		ON		OFF	
	ON				OFF			
2-7	Automatic tear-off				No automatic tear-off			
2-8	CR command produces a line feed				CR command does not produce a line feed			

Built-in features

Print method	24-pin impact
Speed	LQ 82 cps @ 10 cpi 98 cps @ 12 cpi Draft 246 cps @ 10 cpi 295 cps @ 12 cpi High-speed draft 300 cps @ 10 cpi
Print width	8 inches
Paper types	Continuous, Single sheets, Envelopes, Labels
Multipart forms	Original plus 3 copies
Paper paths	Rear, Top
Tractor	Push
Paper parking	Available
Buffer size	6KB
Interfaces	Parallel, Serial
Fonts (typefaces)	Roman, Sans Serif

Options (with model numbers)

Cut-sheet feeders	Single bin: C806141 (Europe), C806271 (America); Double-bin: C806151 (Europe), C806281 (America)
Tractors	Pull: C800071 (Europe), C800161 (America)
Interfaces	#8143, #8148, #8165, #8641, #8642
Ribbons	#7762 (Fabric), #7764 (Film), #7763 (Color)
Font cartridge	#7407

LQ-860 DIP-switch settings

Country (1-4 OFF)	U.S.	France	Germany	U.K.	Denmark	Sweden	Italy	Spain
1-1	ON	ON	ON	ON	OFF	OFF	OFF	OFF
1-2	ON	ON	OFF	OFF	ON	ON	OFF	OFF
1-3	ON	OFF	ON	OFF	ON	OFF	ON	OFF

Character table (1-4 ON)	PC437	PC850	PC860	PC863	PC865
1-1	ON	ON	ON	ON	OFF
1-2	ON	ON	OFF	OFF	ON
1-3	ON	OFF	ON	OFF	ON

	ON	OFF
1-4	Graphics character tables	Italics character table
1-5	Unidirectional printing only	Bidirectional printing possible
1-6	Normal-speed draft	High-speed draft
1-7	Cut-sheet feeder mode on	Cut-sheet feeder mode off
1-8	1-inch skip-over-perforation	No skip-over-perforation

Paper length	11.7 inches	12 inches	8.5 inches	11 inches
2-1	ON	ON	OFF	OFF
2-2	ON	OFF	ON	OFF

Interface	Serial (none)	Serial (even)	Serial (odd)	Parallel
2-3	ON	ON	OFF	OFF
2-4	ON	OFF	ON	OFF

Baud	300	19,200	1,200	9,600
2-5	ON	ON	OFF	OFF
2-6	ON	OFF	ON	OFF

	ON	OFF
2-7	Automatic tear-off	No automatic tear-off
2-8	CR command produces a line feed	CR command does not produce a line feed

Built-in features

Print method	24-pin impact
Speed	LQ 82 cps @ 10 cpi 98 cps @ 12 cpi Draft 246 cps @ 10 cpi 295 cps @ 12 cpi High-speed draft 300 cps @ 10 cpi
Print width	8 inches
Paper types	Continuous, Single sheets, Envelopes, Labels
Multipart forms	Original plus 3 copies
Paper paths	Rear, Top
Tractor	Push
Paper parking	Available
Buffer size	6KB
Interfaces	Parallel, Serial
Fonts (typefaces)	Roman, Sans Serif

Options (with model numbers)

Cut-sheet feeders	C806141 (Single-bin), C806151 (Double-bin)
Tractor	C800071 (Pull)
Interfaces	#8143, #8148, #8165, #8641, #8642
Ribbons	#7762 (Fabric), #7764 (Film), #7763 (Color)
Font cartridge	#7407

LQ-860+ DIP-switch settings

Country (1-4 OFF)	U.S.	France	Germany	U.K.	Denmark	Sweden	Italy	Spain
1-1	ON	ON	ON	ON	OFF	OFF	OFF	OFF
1-2	ON	ON	OFF	OFF	ON	ON	OFF	OFF
1-3	ON	OFF	ON	OFF	ON	OFF	ON	OFF

Character table (1-4 ON)	PC437	PC850	PC860	PC863	PC865
1-1	ON	ON	ON	ON	OFF
1-2	ON	ON	OFF	OFF	ON
1-3	ON	OFF	ON	OFF	ON

	ON	OFF
1-4	Graphics character tables	Italics character table
1-5	Unidirectional printing only	Bidirectional printing possible
1-6	Normal-speed draft	High-speed draft
1-7	Cut-sheet feeder mode on	Cut-sheet feeder mode off
1-8	1-inch skip-over-perforation	No skip-over-perforation

Paper length	11.7 inches	12 inches	8.5 inches	11 inches
2-1	ON	ON	OFF	OFF
2-2	ON	OFF	ON	OFF

Interface	Serial (none)	Serial (even)	Serial (odd)	Parallel
2-3	ON	ON	OFF	OFF
2-4	ON	OFF	ON	OFF

Baud	300	19,200	1,200	9,600
2-5	ON	ON	OFF	OFF
2-6	ON	OFF	ON	OFF

	ON	OFF
2-7	Automatic tear-off	No automatic tear-off
2-8	CR command produces a line feed	CR command does not produce a line feed

Built-in features

Print method	24-pin impact
Speed	LQ 92 cps @ 10 cpi 110 cps @ 12 cpi Draft 275 cps @ 10 cpi 330 cps @ 12 cpi High-speed draft 300 cps @ 10 cpi
Print width	8 inches
Paper types	Continuous, Single sheets, Envelopes, Labels
Multipart forms	Original plus 3 copies
Paper paths	Rear, Top, Bottom, Front
Tractors	Push, Pull
Paper parking	Available
Buffer size	64KB
Interface	Parallel
Fonts (typefaces)	Roman, Sans Serif, Courier, Prestige, Script, OCR B, Orator, Orator S, Script C

Options (with model numbers)

Cut-sheet feeders	C80637*, C80638* (Single-bin)
Tractor	C80020* (Pull)
Interfaces	C82305*, C82306*, C80637*, C82308*
Ribbons	#7753 (Fabric), #7768 (Film)

*The last digit of the option model numbers shown above as an asterisk varies by country.

LQ-870 DIP-switch settings

Country (1-4 OFF)	U.S.	France	Germany	U.K.	Denmark	Sweden	Italy	Spain
1-1	ON	ON	ON	ON	OFF	OFF	OFF	OFF
1-2	ON	ON	OFF	OFF	ON	ON	OFF	OFF
1-3	ON	OFF	ON	OFF	ON	OFF	ON	OFF

Character table (1-4 ON)	PC437	PC850	PC860	PC863	PC865
1-1	ON	ON	ON	ON	OFF
1-2	ON	ON	OFF	OFF	ON
1-3	ON	OFF	ON	OFF	ON

	ON	OFF
1-4	Graphics character tables	Italics character table
1-5	Unidirectional printing only	Bidirectional printing possible
1-6	High-speed draft printing	Normal draft printing
1-7	No buffer	64-KB buffer
1-8	1-inch skip-over-perforation	No skip-over-perforation

Paper length	11.7 inches	12 inches	8.5 inches	11 inches
2-1	ON	ON	OFF	OFF
2-2	ON	OFF	ON	OFF

	ON	OFF
2-3	Automatic tear-off	No automatic tear-off
2-4	CR command produces a line feed	CR command does not produce a line feed

Built-in features

Print method	24-pin impact
Speed	LQ 73 cps @ 10 cpi 88 cps @ 12 cpi Draft 220 cps @ 10 cpi 264 cps @ 12 cpi
Print width	11 inches
Paper types	Continuous, Single sheets, Envelopes
Multipart forms	Original plus 3 copies
Paper paths	Rear, Top
Tractor	Push
Paper parking	Available
Buffer size	6KB
Interfaces	Parallel, Serial
Fonts (typefaces)	Roman, Sans Serif

Options (with model numbers)

Cut-sheet feeders	#7345 (Single-bin), #7347 (Double-bin)
Tractor	#7313 (Pull)
Interfaces	#8143, #8145, #8148, #8149, #8149(M), #8161, #8165, #8172, #8172(M)
Ribbons	#7753 (Fabric), #7768 (Film)
Font cartridge	#7407

LQ-950 DIP-switch settings

Country	U.S.	France	Germany	U.K.	Denmark	Sweden	Italy	Spain
1-1	ON	ON	ON	ON	OFF	OFF	OFF	OFF
1-2	ON	ON	OFF	OFF	ON	ON	OFF	OFF
1-3	ON	OFF	ON	OFF	ON	OFF	ON	OFF
	ON				OFF			
1-4	Graphics character tables				Italics character table			
1-5	Unidirectional printing only				Bidirectional printing possible			
1-6	Not used				Not used			
1-7	Cut-sheet feeder mode on				Cut-sheet feeder mode off			
1-8	No buffer				6-KB buffer			
2-1	12-inch page length				11-inch page length			
2-2	1-inch skip-over-perforation				No skip-over-perforation			
Interface	Serial (none)		Serial (even)		Serial (odd)		Parallel	
2-3	ON		ON		OFF		OFF	
2-4	ON		OFF		ON		OFF	
Baud	300		4,800		1,200		9,600	
2-5	ON		ON		OFF		OFF	
2-6	ON		OFF		ON		OFF	
	ON				OFF			
2-7	Automatic tear-off				No automatic tear-off			
2-8	CR command produces a line feed				CR command does not produce a line feed			

Built-in features

Print method	24-pin impact
Speed	LQ 60 cps @ 10 cpi Draft 180 cps @ 10 cpi
Print width	13.6 inches
Paper types	Continuous, Single sheets
Multipart forms	Original plus 1 copy
Paper paths	Rear, Top
Paper parking	Not available
Buffer size	7KB or 1KB
Interfaces	Parallel, Serial
Fonts (typefaces)	Roman, Sans Serif
Nonprintable area	22.0 mm at the top of single sheets

Options (with model numbers)

Cut-sheet feeders	#7334 (Single-bin), #8348 (Double-bin)
Tractor	#7304 (Pull)
Interfaces	#8148, #8165, #8172
Ribbons	N/A
Font cartridges	#7400, #7401, #7402, #7403

LQ-1000 DIP-switch settings

Country	U.S.	France	Germany	U.K.	Denmark	Sweden	Italy	Spain
1-1	ON	ON	ON	ON	OFF	OFF	OFF	OFF
1-2	ON	ON	OFF	OFF	ON	ON	OFF	OFF
1-3	ON	OFF	ON	OFF	ON	OFF	ON	OFF

	ON	OFF
1-4	7-KB buffer	1-KB buffer
1-5	Draft printing	LQ printing
1-6	Condensed printing	Noncondensed printing
1-7	1-inch skip-over-perforation	No skip-over-perforation
1-8	Cut-sheet feeder mode on	Cut-sheet feeder mode off
2-1	12-inch page length	11-inch page length
2-2	Identity module	Internal firmware

Interface	Serial (none)	Serial (even)	Serial (odd)	Parallel
2-3	ON	ON	OFF	OFF
2-4	ON	OFF	ON	OFF

Baud	9,600	4,800	1,200	300
2-5	ON	ON	OFF	OFF
2-6	ON	OFF	ON	OFF

	ON	OFF
2-7	SLCT IN on	SLCT IN off
2-8	CR command produces a line feed	CR command does not produce a line feed

Built-in features

Print method	24-pin impact
Speed	LQ 50 cps @ 10 cpi 60 cps @ 12 cpi Draft 150 cps @ 10 cpi 180 cps @ 12 cpi
Print width	13.6 inches
Paper types	Continuous, Single sheets, Envelopes, Labels
Multipart forms	Original plus 2 copies
Paper paths	Rear, Top
Tractor	Push
Paper parking	Available
Buffer size	8KB or 1KB
Interface	Parallel
Fonts (typefaces)	Roman, Sans Serif

Options (with model numbers)

Cut-sheet feeder	C80624* (Single-bin)
Tractor	C800142 (Pull)
Interfaces	#8143, #8148, #8165, #8641, #8642, #8172
Ribbons	#7754 (Fabric), #7770 (Film)
Font cartridge	#7407

*The last digit of the option model numbers shown above as an asterisk varies by country.

LQ-1010 DIP-switch settings

Country	U.S.	France	Germany	U.K.	Denmark	Sweden	Italy	Spain
1-1	ON	ON	ON	ON	OFF	OFF	OFF	OFF
1-2	ON	ON	OFF	OFF	ON	ON	OFF	OFF
1-3	ON	OFF	ON	OFF	ON	OFF	ON	OFF

Font	Draft	Sans Serif	Font Cartridge	Roman
1-4	ON	ON	OFF	OFF
1-5	ON	OFF	ON	OFF

	ON	OFF
1-6	Condensed printing	Noncondensed printing
1-7	Graphics character table	Italics character table
1-8	Cut-sheet feeder mode on	Cut-sheet feeder mode off
2-1	12-inch page length	11-inch page length
2-2	Automatic tear-off	No automatic tear-off
2-3	1-inch skip-over-perforation	No skip-over-perforation
2-4	CR command produces a line feed	CR command does not produce a line feed
2-5	8-KB buffer	1-KB buffer
2-6	Bidirectional printing possible	Unidirectional printing only

Pitch	Proportional	12 cpi	15 cpi	10 cpi
2-7	ON	ON	OFF	OFF
2-8	ON	OFF	ON	OFF

Built-in features

Print method	24-pin impact
Speed	LQ 53 cps @ 10 cpi 64 cps @ 12 cpi Draft 160 cps @ 10 cpi 192 cps @ 12 cpi
Print width	13.6 inches
Paper types	Continuous, Single sheets, Envelopes, Labels
Multipart forms	Original plus 2 copies
Paper paths	Rear, Top
Tractor	Push
Paper parking	Available
Buffer size	8KB or 1KB
Interface	Parallel
Fonts (typefaces)	Roman, Sans Serif, Courier, Prestige, Script, OCR B, OCR A, Orator, Orator S

Options (with model numbers)

Cut-sheet feeder	C806242 (Single-bin)
Tractor	C800142 (Pull)
Interfaces	#8143, #8148, #8165, C823032, C823021
Ribbons	#7754 (Fabric), #7770 (Film)

LQ-1010 DIP-switch settings

Country (1-7 OFF)	U.S.	France	Germany	U.K.	Denmark	Sweden	Italy	Spain
1-1	ON	ON	ON	ON	OFF	OFF	OFF	OFF
1-2	ON	ON	OFF	OFF	ON	ON	OFF	OFF
1-3	ON	OFF	ON	OFF	ON	OFF	ON	OFF

Character table (1-7 ON)	PC437	PC850	PC860	PC863	PC865
1-1	ON	ON	ON	ON	OFF
1-2	ON	ON	OFF	OFF	ON
1-3	ON	OFF	ON	OFF	ON

Paper length	11.7 inches	12 inches	8.5 inches	11 inches
1-4	ON	ON	OFF	OFF
1-5	ON	OFF	ON	OFF

	ON	OFF
1-6	Condensed printing	Noncondensed printing
1-7	Graphics character tables	Italics character table
1-8	Cut-sheet feeder mode on	Cut-sheet feeder mode off
2-1	Not used	Not used
2-2	Automatic tear-off	No automatic tear-off
2-3	1-inch skip-over-perforation	No skip-over-perforation
2-4	CR command produces a line feed	CR command does not produce a line feed
2-5	8-KB buffer	1-KB buffer
2-6	Bidirectional printing possible	Unidirectional printing only

Pitch	Proportional	12 cpi	15 cpi	10 cpi
2-7	ON	ON	OFF	OFF
2-8	ON	OFF	ON	OFF

Built-in features

Print method	24-pin impact
Speed	LQ 73 cps @ 10 cpi 88 cps @ 12 cpi Draft 220 cps @ 10 cpi 264 cps @ 12 cpi
Print width	13.6 inches
Paper types	Continuous, Single sheets
Multipart forms	Original plus 3 copies
Paper paths	Rear, Top
Tractor	Push
Paper parking	Available
Buffer size	6KB
Interfaces	Parallel, Serial
Fonts (typefaces)	Roman, Sans Serif

Options (with model numbers)

Cut-sheet feeders	#7340 (Single-bin), #7348 (Double-bin)
Tractor	#7312 (Pull)
Interfaces	#8143, #8145, #8148, #8149, #8149(M), #8161, #8165, #8172, #8172(M)
Ribbons	#7754 (Fabric), #7770 (Film)
Font cartridge	#7407

LQ-1050 DIP-switch settings

Country	U.S.	France	Germany	U.K.	Denmark	Sweden	Italy	Spain
1-1	ON	ON	ON	ON	OFF	OFF	OFF	OFF
1-2	ON	ON	OFF	OFF	ON	ON	OFF	OFF
1-3	ON	OFF	ON	OFF	ON	OFF	ON	OFF
	ON				OFF			
1-4	Graphics character table				Italics character table			
1-5	Unidirectional printing only				Bidirectional printing possible			
1-6	Not used				Not used			
1-7	Cut-sheet feeder mode on				Cut-sheet feeder mode off			
1-8	No buffer				6-KB buffer			
2-1	12-inch page length				11-inch page length			
2-2	1-inch skip-over perforation				No skip-over-perforation			
Interface	Serial (none)		Serial (even)		Serial (odd)		Parallel	
2-3	ON		ON		OFF		OFF	
2-4	ON		OFF		ON		OFF	
Baud	300		4,800		1,200		9,600	
2-5	ON		ON		OFF		OFF	
2-6	ON		OFF		ON		OFF	
	ON				OFF			
2-7	Automatic tear-off				No automatic tear-off			
2-8	CR command produces a line feed				CR command does not produce a line feed			

Built-in features

Print method	24-pin impact
Speed	LQ 82 cps @ 10 cpi 98 cps @ 12 cpi Draft 246 cps @ 10 cpi 295 cps @ 12 cpi High-speed draft 300 cps @ 10 cpi
Print width	13.6 inches
Paper types	Continuous, Single sheets, Envelopes, Labels
Multipart forms	Original plus 3 copies
Paper paths	Rear, Top
Tractor	Push
Paper parking	Available
Buffer size	6KB
Interfaces	Parallel, Serial
Fonts (typefaces)	Roman, Sans Serif, Courier*, Prestige*, Script*, OCR B*, OCR A*, Orator*, Orator S*

Options (with model numbers)

Cut-sheet feeders	#7340 (Single-bin), #7348 (Double-bin)
Tractor	#7312 (Pull)
Interfaces	#8143, #8148, #8165, #8641, #8642
Ribbons	#7754 (Fabric), #7770 (Film)
Font cartridge	#7407**

*Built-in from 1991 on. **Discontinued from 1991 on.

LQ-1050 DIP-switch settings

Country (1-4 OFF)	U.S.	France	Germany	U.K.	Denmark	Sweden	Italy	Spain
1-1	ON	ON	ON	ON	OFF	OFF	OFF	OFF
1-2	ON	ON	OFF	OFF	ON	ON	OFF	OFF
1-3	ON	OFF	ON	OFF	ON	OFF	ON	OFF

Character table (1-4 ON)	PC437	PC850	PC860	PC863	PC865
1-1	ON	ON	ON	ON	OFF
1-2	ON	ON	OFF	OFF	ON
1-3	ON	OFF	ON	OFF	ON

	ON	OFF
1-4	Graphics character tables	Italics character table
1-5	Bidirectional printing possible	Unidirectional printing only
1-6	Normal-speed draft	High-speed draft
1-7	Cut-sheet feeder mode on	Cut-sheet feeder mode off
1-8	1-inch skip-over-perforation	No skip-over-perforation

Paper length	11.7 inches	12 inches	8.5 inches	11 inches
2-1	ON	ON	OFF	OFF
2-2	ON	OFF	ON	OFF

Interface	Serial (none)	Serial (even)	Serial (odd)	Parallel
2-3	ON	ON	OFF	OFF
2-4	ON	OFF	ON	OFF

Baud	300	19,200	1,200	9,600
2-5	ON	ON	OFF	OFF
2-6	ON	OFF	ON	OFF

	ON	OFF
2-7	Automatic tear-off	No automatic tear-off
2-8	CR command produces a line feed	CR command does not produce a line feed

Built-in features

Print method	24-pin impact
Speed	LQ 82 cps @ 10 cpi 98 cps @ 12 cpi Draft 246 cps @ 10 cpi 295 cps @ 12 cpi High-speed draft 300 cps @ 10 cpi
Print width	13.6 inches
Paper types	Continuous, Single sheets, Envelopes, Labels
Multipart forms	Original plus 3 copies
Paper paths	Rear, Top
Tractor	Push
Paper parking	Available
Buffer size	6KB
Interfaces	Parallel, Serial
Fonts (typefaces)	Roman, Sans Serif

Options (with model numbers)

Cut-sheet feeders	#7340 (Single-bin), #7348 (Double-bin)
Tractor	#7312 (Pull)
Interfaces	#8143, #8148, #8165, #8641, #8642
Ribbons	#7754 (Fabric), #7770 (Film)
Font cartridge	#7407

LQ-1050+ DIP-switch settings

Country	U.S.	France	Germany	U.K.	Denmark	Sweden	Italy	Spain
1-1	ON	ON	ON	ON	OFF	OFF	OFF	OFF
1-2	ON	ON	OFF	OFF	ON	ON	OFF	OFF
1-3	ON	OFF	ON	OFF	ON	OFF	ON	OFF
	ON				OFF			
1-4	Graphics character table				Italics character table			
1-5	Unidirectional printing only				Bidirectional printing possible			
1-6	Normal draft				High-speed draft			
1-7	Cut-sheet feeder mode on				Cut-sheet feeder mode off			
1-8	No buffer				6-KB buffer			
2-1	12-inch page length				11-inch page length			
2-2	1-inch skip-over perforation				No skip-over-perforation			
Interface	Serial (none)		Serial (even)		Serial (odd)		Parallel	
2-3	ON		ON		OFF		OFF	
2-4	ON		OFF		ON		OFF	
Baud	300		19,200		1,200		9,600	
2-5	ON		ON		OFF		OFF	
2-6	ON		OFF		ON		OFF	
	ON				OFF			
2-7	Automatic tear-off				No automatic tear-off			
2-8	CR command produces a line feed				CR command does not produce a line feed			

Built-in features

Print method	24-pin impact
Speed	LQ 75 cps @ 10 cpi 90 cps @ 12 cpi Draft 225 cps @ 10 cpi 270 cps @ 12 cpi High-speed draft 300 cps @ 10 cpi
Print width	13.6 inches
Paper types	Continuous, Single sheets, Envelopes, Labels
Multipart forms	Original plus 3 copies
Paper paths	Rear, Top
Tractor	Push
Paper parking	Available
Buffer size	6KB
Interfaces	Parallel, Serial
Fonts (typefaces)	Roman, Sans Serif

Options (with model numbers)

Cut-sheet feeders	C806181 (Single-bin), C806191 (Double-bin)
Tractor	C800101 (Pull)
Interfaces	#8143, #8148, #8165, #8641, #8642
Ribbons	#7762 (Fabric), #7764 (Film), #7763 (Color)
Font cartridge	#7407

LQ-1060 DIP-switch settings

Country	U.S.	France	Germany	U.K.	Denmark	Sweden	Italy	Spain
1-1	ON	ON	ON	ON	OFF	OFF	OFF	OFF
1-2	ON	ON	OFF	OFF	ON	ON	OFF	OFF
1-3	ON	OFF	ON	OFF	ON	OFF	ON	OFF
	ON				OFF			
1-4	Graphics character table				Italics character table			
1-5	Unidirectional printing only				Bidirectional printing possible			
1-6	Normal-speed draft				High-speed draft			
1-7	Cut-sheet feeder mode on				Cut-sheet feeder mode off			
1-8	No buffer				6-KB buffer			
2-1	12-inch page length				11-inch page length			
2-2	1-inch skip-over perforation				No skip-over-perforation			
Interface	Serial (none)		Serial (even)		Serial (odd)		Parallel	
2-3	ON		ON		OFF		OFF	
2-4	ON		OFF		ON		OFF	
Baud	300		19,200		1,200		9,600	
2-5	ON		ON		OFF		OFF	
2-6	ON		OFF		ON		OFF	
	ON				OFF			
2-7	Automatic tear-off				No automatic tear-off			
2-8	CR command produces a line feed				CR command does not produce a line feed			

Built-in features

Print method	24-pin impact
Speed	LQ 82 cps @ 10 cpi 98 cps @ 12 cpi Draft 246 cps @ 10 cpi 295 cps @ 12 cpi High-speed draft 300 cps @ 10 cpi
Print width	13.6 inches
Paper types	Continuous, Single sheets, Envelopes, Labels
Multipart forms	Original plus 3 copies
Paper paths	Rear, Top
Tractor	Push
Paper parking	Available
Buffer size	6KB
Interfaces	Parallel, Serial
Fonts (typefaces)	Roman, Sans Serif

Options (with model numbers)

Cut-sheet feeders	C806181 (Single-bin), C806191 (Double-bin)
Tractor	C800101 (Pull)
Interfaces	#8143, #8148, #8165, #8641, #8642
Ribbons	#7762 (Fabric), #7764 (Film), #7763 (Color)
Font cartridge	#7407

LQ-1060 DIP-switch settings

Country (1-4 OFF)	U.S.	France	Germany	U.K.	Denmark	Sweden	Italy	Spain
1-1	ON	ON	ON	ON	OFF	OFF	OFF	OFF
1-2	ON	ON	OFF	OFF	ON	ON	OFF	OFF
1-3	ON	OFF	ON	OFF	ON	OFF	ON	OFF

Character table (1-4 ON)	PC437	PC850	PC860	PC863	PC865
1-1	ON	ON	ON	ON	OFF
1-2	ON	ON	OFF	OFF	ON
1-3	ON	OFF	ON	OFF	ON

	ON	OFF
1-4	Graphics character tables	Italics character table
1-5	Unidirectional printing only	Bidirectional printing possible
1-6	Normal-speed draft	High-speed draft
1-7	Cut-sheet feeder mode on	Cut-sheet feeder mode off
1-8	1-inch skip-over-perforation	No skip-over-perforation

Paper length	11.7 inches	12 inches	8.5 inches	11 inches
2-1	ON	ON	OFF	OFF
2-2	ON	OFF	ON	OFF

Interface	Serial (none)	Serial (even)	Serial (odd)	Parallel
2-3	ON	ON	OFF	OFF
2-4	ON	OFF	ON	OFF

Baud	300	19,200	1,200	9,600
2-5	ON	ON	OFF	OFF
2-6	ON	OFF	ON	OFF

	ON	OFF
2-7	Automatic tear-off	No automatic tear-off
2-8	CR command produces a line feed	CR command does not produce a line feed

Built-in features

Print method	24-pin impact
Speed	LQ 82 cps @ 10 cpi 98 cps @ 12 cpi Draft 246 cps @ 10 cpi 295 cps @ 12 cpi High-speed draft 300 cps @ 10 cpi
Print width	13.6 inches
Paper types	Continuous, Single sheets, Envelopes, Labels
Multipart forms	Original plus 3 copies
Paper paths	Rear, Top
Tractor	Push
Paper parking	Available
Buffer size	6KB
Interfaces	Parallel, Serial
Fonts (typefaces)	Roman, Sans Serif

Options (with model numbers)

Cut-sheet feeders	C806181 (Single-bin), C806191 (Double-bin)
Tractor	C800101 (Pull)
Interfaces	#8143, #8148, #8165, #8641, #8642
Ribbons	#7762 (Fabric), #7764 (Film), #7763 (Color)
Font cartridge	#7407

LQ-1060+ DIP-switch settings

Country (1-4 OFF)	U.S.	France	Germany	U.K.	Denmark	Sweden	Italy	Spain
1-1	ON	ON	ON	ON	OFF	OFF	OFF	OFF
1-2	ON	ON	OFF	OFF	ON	ON	OFF	OFF
1-3	ON	OFF	ON	OFF	ON	OFF	ON	OFF

Character table (1-4 ON)	PC437	PC850	PC860	PC863	PC865
1-1	ON	ON	ON	ON	OFF
1-2	ON	ON	OFF	OFF	ON
1-3	ON	OFF	ON	OFF	ON

	ON	OFF
1-4	Graphics character tables	Italics character table
1-5	Unidirectional printing only	Bidirectional printing possible
1-6	Normal-speed draft	High-speed draft
1-7	Cut-sheet feeder mode on	Cut-sheet feeder mode off
1-8	1-inch skip-over-perforation	No skip-over-perforation

Paper length	11.7 inches	12 inches	8.5 inches	11 inches
2-1	ON	ON	OFF	OFF
2-2	ON	OFF	ON	OFF

Interface	Serial (none)	Serial (even)	Serial (odd)	Parallel
2-3	ON	ON	OFF	OFF
2-4	ON	OFF	ON	OFF

Baud	300	19,200	1,200	9,600
2-5	ON	ON	OFF	OFF
2-6	ON	OFF	ON	OFF

	ON	OFF
2-7	Automatic tear-off	No automatic tear-off
2-8	CR command produces a line feed	CR command does not produce a line feed

Built-in features

Print method	24-pin impact
Speed	LQ 70 cps @ 10 cpi 84 cps @ 12 cpi Draft 210 cps @ 10 cpi 252 cps @ 12 cpi High-speed draft 225 cps @ 10 cpi
Print width	13.6 inches
Paper types	Continuous, Single sheets, Envelopes, Labels
Multipart forms	Original plus 3 copies
Paper paths	Rear, Top, Bottom, Front
Tractors	Push, Pull
Paper parking	Available
Buffer size	8KB
Interface	Parallel
Fonts (typefaces)	Roman, Sans Serif, Courier, Prestige, Script, OCR B, Orator, Orator S, Script C

Options (with model numbers)

Cut-sheet feeders	C80639*, C80640* (Single-bin)
Tractor	C80022* (Pull)
Interfaces	C82305*, C82306*, C82307*, C82308*
Ribbons	#7754 (Fabric), #7770 (Film)

*The last digit of the option model numbers shown above as an asterisk varies by country.

LQ-1070 DIP-switch setting

Country (1-4 OFF)	U.S.	France	Germany	U.K.	Denmark	Sweden	Italy	Spain
1-1	ON	ON	ON	ON	OFF	OFF	OFF	OFF
1-2	ON	ON	OFF	OFF	ON	ON	OFF	OFF
1-3	ON	OFF	ON	OFF	ON	OFF	ON	OFF

Character table (1-4 ON)	PC437	PC850	PC860	PC863	PC865
1-1	ON	ON	ON	ON	OFF
1-2	ON	ON	OFF	OFF	ON
1-3	ON	OFF	ON	OFF	ON

	ON	OFF
1-4	Graphics character tables	Italics character table
1-5	Unidirectional printing only	Bidirectional printing possible
1-6	High-speed draft printing	Normal draft printing
1-7	No buffer	8-KB buffer
1-8	1-inch skip-over-perforation	No skip-over-perforation

Paper length	11.7 inches	12 inches	8.5 inches	11 inches
2-1	ON	ON	OFF	OFF
2-2	ON	OFF	ON	OFF

	ON	OFF
2-3	Automatic tear-off	No automatic tear-off
2-4	CR command produces a line feed	CR command does not produce a line feed

Built-in features

Print method	24-pin impact
Speed	LQ 75 cps @ 10 cpi 90 cps @ 12 cpi Draft 225 cps @ 10 cpi 269 cps @ 12 cpi
Print width	13.6 inches
Paper types	Continuous, Single sheets, Envelopes, Labels
Multipart forms	Original plus 3 copies
Paper paths	Rear, Top, Bottom, Front
Tractors	Push, Pull
Paper parking	Available
Buffer size	0, 8KB
Interface	Parallel
Fonts (typefaces)	Roman, Sans Serif, Courier, Prestige, Script, OCR B, Orator, Orator S, Script C, Roman T, Sans Serif H
Nonprintable area	5.3 mm at the top of single sheets

Options (with model numbers)

Cut-sheet feeders	C80639* (Single-bin), C80640* (High-capacity)
Tractor	C80022* (Pull)
Interfaces	C82305*, C82306*, C82307*, C82308*, C82310*, C82311*, C82313*
Ribbons	#7754 (Fabric), #7770 (Film)

*The last digit of the option model numbers shown above as an asterisk varies by country.

LQ-1070+ DIP-switch setting

Country (1-4 OFF)	U.S.	France	Germany	U.K.	Denmark I	Sweden	Italy	Spain I
1-1	ON	ON	ON	ON	OFF	OFF	OFF	OFF
1-2	ON	ON	OFF	OFF	ON	ON	OFF	OFF
1-3	ON	OFF	ON	OFF	ON	OFF	ON	OFF

Character table (1-4 ON)	PC437	PC850	PC860	PC863	PC865	BRASCI ⁺ PC437 ^{**}	Abicomp ⁺ PC853 ^{**}	PC437 ⁺ PC852 ^{**}
1-1	ON	ON	ON	ON	OFF	OFF	OFF	OFF
1-2	ON	ON	OFF	OFF	ON	ON	OFF	OFF
1-3	ON	OFF	ON	OFF	ON	OFF	ON	OFF

*These character tables are not available on the European version.

**These character tables are available only on the European version.

	ON	OFF
1-4	Graphics character tables	Italics character table
1-5	Unidirectional printing only	Bidirectional printing possible
1-6	IBM emulation*	ESC/P 2
1-7	No buffer	8-KB buffer
1-8	1-inch skip-over-perforation	No skip-over-perforation

*DIP switch 1-6 functions only on the European version of this printer.

Paper length	11.7 inches	12 inches	8.5 inches	11 inches
2-1	ON	ON	OFF	OFF
2-2	ON	OFF	ON	OFF
	ON		OFF	
2-3	Automatic tear-off		No automatic tear-off	
2-4	Auto line feed		No auto line feed	

DIP-switch settings for IBM emulation mode

Character table (1-6 ON)	437	850	860	863	865	437 Greek	853	852
1-1	ON	ON	ON	ON	OFF	OFF	OFF	OFF
1-2	ON	ON	OFF	OFF	ON	ON	OFF	OFF
1-3	ON	OFF	ON	OFF	ON	OFF	ON	OFF
	ON				OFF			
1-4	Character set 1				Character set 2			
1-8	Alternate graphics mode on*				Alternate graphics mode off			
2-1	12-inch page length (cont. paper)				11-inch page length (cont. paper)			
2-2	Auto CR enabled				Auto CR disabled			

*With DIP-switch 1-8 ON, ESC 3, ESC A, ESC J, and ESC * function the same as in ESC/P.

Built-in features

Print method	24-pin impact
Speed	LQ 73 cps @ 10 cpi 88 cps @ 12 cpi Draft 220 cps @ 10 cpi 264 cps @ 12 cpi High-speed draft 300 cps @ 10 cpi
Print width	13.6 inches
Paper types	Continuous, Single sheets, Envelopes, Labels
Multipart forms	Original plus 3 copies
Paper paths	Rear, Top, Bottom, Front
Tractors	Push, Pull
Paper parking	Available
Buffer size	64KB
Interface	Parallel
Fonts (typefaces)	Roman, Sans Serif, Courier, Prestige, Script, OCR B, Orator, Orator S, Script C

Options (with model numbers)

Cut-sheet feeders	C80639*, C80640* (Single-bin)
Tractor	C80021* (Pull)
Interfaces	C82305*, C82306*, C82307*, C82308*
Ribbons	#7754 (Fabric), #7770 (Film)

*The last digit of the option model numbers shown above as an asterisk varies by country.

LQ-1170 DIP-switch setting

Country (1-4 OFF)	U.S.	France	Germany	U.K.	Denmark	Sweden	Italy	Spain
1-1	ON	ON	ON	ON	OFF	OFF	OFF	OFF
1-2	ON	ON	OFF	OFF	ON	ON	OFF	OFF
1-3	ON	OFF	ON	OFF	ON	OFF	ON	OFF

Character table (1-4 ON)	PC437	PC850	PC860	PC863	PC865
1-1	ON	ON	ON	ON	OFF
1-2	ON	ON	OFF	OFF	ON
1-3	ON	OFF	ON	OFF	ON

	ON	OFF
1-4	Graphics character tables	Italics character table
1-5	Unidirectional printing only	Bidirectional printing possible
1-6	High-speed draft printing	Normal draft printing
1-7	No buffer	64-KB buffer
1-8	1-inch skip-over-perforation	No skip-over-perforation

Paper length	11.7 inches	12 inches	8.5 inches	11 inches
2-1	ON	ON	OFF	OFF
2-2	ON	OFF	ON	OFF

	ON	OFF
2-3	Automatic tear-off	No automatic tear-off
2-4	CR command produces a line feed	CR command does not produce a line feed

Built-in features

Print method	24-pin impact
Speed	LQ 67 cps @ 10 cpi Draft 200 cps @ 10 cpi
Print width	13.6 inches
Paper types	Continuous, Single sheets
Multipart forms	Original plus 3 copies
Paper paths	Rear, Top
Paper parking	Not available
Buffer size	2KB
Interface	Parallel
Font (typeface)	Roman
Nonprintable area	22.0 mm at the top of single sheets

Options (with model numbers)

Cut-sheet feeder	#8344 (Double-bin)
Tractor	#8303 (Pull)
Interfaces	#8148, #8165, #8172
Ribbon	#8753 (Fabric)

LQ-1500 DIP-switch settings

	ON				OFF			
1-1	No buffer				2-KB buffer			
1-2	Paper-end sensor off				Paper-end sensor on			
1-3	CR command produces a line feed				CR command does not produce a line feed			
1-4	Not used				Not used			
Country	U.S.	France	Germany	U.K.	Denmark	Sweden	Italy	Spain
2-1	ON	ON	ON	ON	OFF	OFF	OFF	OFF
2-2	ON	ON	OFF	OFF	ON	ON	OFF	OFF
2-3	ON	OFF	ON	OFF	ON	OFF	ON	OFF
	ON				OFF			
2-4	12-inch page length				11-inch page length			
2-5	1-inch skip-over-perforation				No skip-over-perforation			
2-6	Bell disabled				Bell available			
2-7	LQ printing				Draft printing			
2-8	Receive <u>SLCT IN</u> signal				<u>SLCT IN</u> signal ignored			

Built-in features

Print method	24-pin impact
Speed	LQ 92 cps @ 10 cpi 110 cps @ 12 cpi Draft 275 cps @ 10 cpi 330 cps @ 12 cpi High-speed draft 300 cpi @ 10 cpi
Print width	13.6 inches
Paper types	Continuous, Single sheets, Envelopes, Labels, Cards, Roll paper
Multipart forms	Original plus 3 copies
Paper paths	Front, Rear, Bottom In, Top Out
Tractors	Push, Pull
Paper parking	Available
Buffer size	0, 64KB
Interface	Parallel
Fonts (typefaces)	Roman, Sans Serif, Courier, Prestige, Script, OCR B, Orator, Orator S, Script C, Roman T, Sans Serif H
Bar codes	EAN-13, EAN-8, Interleaved 2 of 5, UPC-A, UPC-E, Code 39, Code 128, POSTNET
Nonprintable area	4.2 mm at the top and bottom of single sheets

Options (with model numbers)

Cut-sheet feeders	C80673* (High-capacity), C80674* (Second-bin)
Pull tractor unit	C80032*
Roll paper holder	#8310
Interfaces	C82305*, C82306*, C82307*, C82308*, C82310*, C82311*, C82312*, C82313*, C82314*, C82315*, C82331*
Ribbons	S015083/S015086 (Cartridge), S010031/S010033 (Pack)

*The last digit of the option model numbers shown above as an asterisk varies by country.

LQ-2070 default-setting mode

This printer has no DIP switches; however, the following settings can be made in a special default-setting mode.

Setting	Options
Page length for front tractor	3, 3.5, 4, 5.5, 6, 7, 8, 8.5, 11, 70/6, 12, 14, 17, or Others inches
Page length for rear tractor	3, 3.5, 4, 5.5, 6, 7, 8, 8.5, 11, 70/6, 12, 14, 17, or Others inches
Skip-over-perforation	On or Off
Auto tear off	On or Off
Auto line feed	On or Off
Print direction	Auto, Bi-d or Uni-d
I/F mode	Auto, Parallel, or Option
Auto I/F wait time	10 or 30 sec.
Software	ESC/P 2 or IBM 2391 Plus
Character table	Italic, PC437, PC437 Greek*, PC774*, PC850, PC852*, PC853*, PC855*, PC857*, PC860, PC861, PC863, PC864*, PC865, PC866*, PC866 LAT*, PC869*, BRASCI, Abicomp, Roman 8, ISO Latin 1, ISO 8859-2*, MAZOWIA*, Code MJK*, ISO 8859-7*, ISO Latin 1T*, Bulgaria*, Estonia*
International character set	U.S.A., France, Germany, U.K., Denmark 1, Sweden, Italy, Spain 1
0 slash	0 or Ø
High speed draft	On or Off
Input buffer	On or Off
Buzzer	On or Off
Auto CR	On or Off †
A.G.M.	On or Off †
Font	OCR-B, Orator, Orator-S, Script C, Roman T (PS), Sans Serif H (PS)
Roll paper	On or Off

* Availability varies by country.

† This setting is available only in IBM mode.

Built-in features

Print method	24-pin impact
Speed	LQ 73 cps @ 10 cpi 88 cps @ 12 cpi Draft 220 cps @ 10 cpi 264 cps @ 12 cpi High-speed draft 300 cps @ 10 cpi
Print width	13.6 inches
Paper types	Continuous, Single sheets, Envelopes, Labels, Cards, Roll paper
Multipart forms	Original plus 4 copies
Paper paths	Front, Rear, Bottom In, Top Out
Tractors	Push, Pull
Paper parking	Available
Buffer size	0 or 64KB
Interface	Parallel
Fonts (typefaces)	Roman, Sans Serif, Courier, Prestige, Script, OCR B, Orator, Orator S, Script C, Roman T, Sans Serif H
Bar codes	EAN-13, EAN-8, Interleaved 2 of 5, UPC-A, UPC-E, Code 39, Code 128, POSTNET
Nonprintable area	4.2 mm at the top and bottom of single sheets

Options (with model numbers)

Cut-sheet feeders	C80673* (High-capacity), C80674* (Second-bin)
Pull tractor unit	C80032*
Roll paper holder	#8310
Interfaces	C82305*, C82306*, C82307*, C82308*, C82310*, C82311*, C82312*, C82313*, C82314*, C82315*, C82331*
Ribbons	S015083 (Cartridge), S010031 (Pack)

*The last digit of the option model numbers shown above as an asterisk varies by country.

LQ-2170 default-setting mode

This printer has no DIP switches; however, the following settings can be made in a special default-setting mode.

Setting	Options
Page length for front tractor	3, 3.5, 4, 5.5, 6, 7, 8, 8.5, 11, 70/6, 12, 14, 17, or Others inches
Page length for rear tractor	3, 3.5, 4, 5.5, 6, 7, 8, 8.5, 11, 70/6, 12, 14, 17, or Others inches
Skip-over-perforation	On or Off
Auto tear off	On or Off
Auto line feed	On or Off
Print direction	Auto, Bi-d or Uni-d
I/F mode	Auto, Parallel, or Option
Auto I/F wait time	10 or 30 sec.
Software	ESC/P 2 or IBM 2391 Plus
Character table	Italic, PC437, PC437 Greek*, PC774*, PC850, PC852*, PC853*, PC855*, PC857*, PC860, PC861, PC863, PC864*, PC865, PC866*, PC866 LAT*, PC869*, BRASCI, Abicomp, Roman 8, ISO Latin 1, ISO 8859-2*, MAZOWIA*, Code MJK*, ISO 8859-7*, ISO Latin 1T*, Bulgaria*, Estonia*
International character set	U.S.A., France, Germany, U.K., Denmark 1, Sweden, Italy, Spain 1
0 slash	0 or Ø
High speed draft	On or Off
Input buffer	On or Off
Buzzer	On or Off
Auto CR	On or Off †
A.G.M.	On or Off †
Font	OCR-B, Orator, Orator-S, Script C, Roman T (PS), Sans Serif H (PS)
Roll paper	On or Off

* Availability varies by country.

† This setting is available only in IBM mode.

Built-in features

Print method	24-pin impact
Speed	LQ 90 cps @ 10 cpi 108 cps @ 12 cpi Draft 270 cps @ 10 cpi 324 cps @ 12 cpi
Print width	13.6 inches
Paper types	Continuous, Single sheets, Labels
Multipart forms	Original plus 4 copies
Paper paths	Rear, Top
Tractor	Push
Paper parking	Available
Buffer size	8KB
Interfaces	Parallel, SerialFonts (typefaces)Roman, Sans Serif, Courier, Prestige, Script
Nonprintable area	22.0 mm at the top of single sheets

Options (with model numbers)

Cut-sheet feeders	#8343 (Single-bin), #8346 (Double-bin)
Tractor	#8303 (Pull)
Interfaces	#8131, #8132(W), #8133, #8143, #8145, #8148, #8149, #8149M, #8161, #8165, #8172, #8172M
Ribbons	#7756 (Fabric), #7768 (Film), #7757 (Color)
Color kit	#8391E
Font cartridge	#7404
Image scanner kit	#7392J

Note:

The LQ-2500 has no DIP switches.

Built-in features

Print method	24-pin impact
Speed	LQ 90 cps @ 10 cpi 108 cps @ 12 cpi Draft 270 cps @ 10 cpi 324 cps @ 12 cpi
Print width	13.6 inches
Paper types	Continuous, Single sheets, Labels
Multipart forms	Original plus 4 copies
Paper paths	Rear, Top
Tractor	Push
Paper parking	Available
Buffer size	8KB
Interfaces	Parallel, Serial
Fonts (typefaces)	Roman, Sans Serif, Courier, Prestige, Script
Nonprintable area	22.0 mm at the top of single sheets

Options (with model numbers)

Cut-sheet feeders	#8343 (Single-bin), #8346 (Double-bin)
Tractor	#8308 (Pull)
Interfaces	#8131, #8132(W), #8133, #8143, #8145, #8148, #8149, #8149M, #8161, #8165, #8172, #8172M
Ribbons	#7756 (Fabric), #7768 (Film), #7757 (Color)
Color kit	#8391E
Font cartridge	#7404

Note:

The LQ-2500+ has no DIP switches.

Built-in features

Print method	24-pin impact
Speed	LQ 111 cps @ 10 cpi 133 cps @ 12 cpi Draft 333 cps @ 10 cpi 400 cps @ 12 cpi
Print width	13.6 inches
Paper types	Continuous, Single sheets, Envelopes, Labels
Multipart forms	Original plus 5 copies
Paper paths	Rear, Top
Tractor	Push
Paper parking	Available
Buffer size	8KB
Interface	Parallel
Fonts (typefaces)	Roman, Sans Serif, Courier, Prestige, Script, OCR B, OCR A

Options (with model numbers)

Cut-sheet feeder	#7343 (Double-bin)
Tractor	#7314 (Pull)
Interfaces	#8143, #8145, #8148, #8149, #8149(M), #8161, #8165, #8172, #8172(M), #8133, #8172, #8172M
Ribbons	#7762 (Fabric), #7764 (Film), #7763 (Color)
Font cartridge	#7407

Note:

The LQ-2550 has no DIP switches.

P-80X

Year introduced: 1986
Market: America, Europe, Pacific

Built-in features

Print method 24-element thermal
 Print width 8 inches
 Paper types Single sheets, Roll paper (thermal)
 Paper path Top
 Paper parking Not available
 Interface Serial (6-pin DIN connector)
 Font (typeface) Roman
 Nonprintable area 22.0 mm at the top of single sheets

Options (with model numbers)

Ribbons #8760 (Film, thermal)

P-80X DIP-switch settings

Country	U.S.	France	Germany	U.K.	Denmark	Sweden	Italy	Spain
1-1	ON	ON	ON	ON	OFF	OFF	OFF	OFF
1-2	ON	ON	OFF	OFF	ON	ON	OFF	OFF
1-3	ON	OFF	ON	OFF	ON	OFF	ON	OFF

	ON	OFF
1-4	CR command produces a line feed	CR command does not produce a line feed
2-1	7-bit data length	8-bit data length
2-2	Parity checked	No parity check
2-3	Even parity	Odd parity
2-4	1 stop bit	2 stop bits

bps	75	1,800	200	300	134.5	4,800	600	2,400	110	2,400	300	1,200	150	9,600	1,200	9,600
2-5	ON	ON	ON	ON	ON	ON	ON	ON	OFF	OFF	OFF	OFF	OFF	OFF	OFF	OFF
2-6	ON	ON	ON	ON	OFF	OFF	OFF	OFF	ON	ON	ON	ON	OFF	OFF	OFF	OFF
2-7	ON	ON	OFF	OFF	ON	ON	OFF	OFF	ON	ON	OFF	OFF	ON	ON	OFF	OFF
2-8	ON	OFF	ON	OFF	ON	OFF	ON	OFF	ON	OFF	ON	OFF	ON	OFF	ON	OFF

SQ-850

Year introduced: 1988
Market: Europe, Pacific

Built-in features

Print method	24-nozzle ink jet
Speed	LQ 165 cps @ 10 cpi 198 cps @ 12 cpi Draft 450 cps @ 10 cpi 540 cps @ 12 cpi
Print width	8 inches
Paper types	Continuous, Single sheets, Envelopes, Labels
Paper paths	Rear, Top
Tractor	Push
Paper parking	Available
Buffer size	8KB
Interfaces	Parallel, Serial
Fonts (typefaces)	Roman, Sans Serif, Courier, Prestige, Script

Options (with model numbers)

Cut-sheet feeders	C806081 (Single-bin), C806091 (Double-bin)
Tractor	C800032 (Pull)
Interfaces	#8143, #8148, #8165, #8641, #8642
Ink cartridge	S020002

Note:

The SQ-850 has no DIP switches.

Built-in features

Print method	24-nozzle ink jet		
Speed	LQ	165 cps @ 10 cpi	198 cps @ 12 cpi
	Draft	500 cps @ 10 cpi	600 cps @ 12 cpi
		8 inches	
Paper types	Continuous, Single sheets, Envelopes, Labels		
Paper paths	Rear, Top		
Tractor	Push		
Paper parking	Available		
Buffer size	8KB		
Interfaces	Parallel, Serial		
Fonts (typefaces)	Roman, Sans Serif, Courier, Prestige, Script, OCR B, OCR A, Orator, Orator S		

Options (with model numbers)

Cut-sheet feeders	C806081 (Single-bin), C806091 (Double-bin)
Tractor	C800032 (Pull)
Interfaces	#8143, #8148, #8165, #8641, #8642
Ink cartridge	S020002

Note:

The SQ-850 has no DIP switches.

Built-in features

Print method	48-nozzle ink jet
Speed	LQ 200 cps @ 10 cpi 240 cps @ 12 cpi Draft 550 cps @ 10 cpi 660 cps @ 12 cpi
Print width	8 inches
Paper types	Continuous, Single sheets, Envelopes, Labels, Roll paper
Paper paths	Rear, Top, Front
Tractor	Push
Paper parking	Available
Buffer size	16KB or 128KB
Interface	Parallel
Fonts (typefaces)	Roman, Sans Serif, Courier, Prestige, Script, Orator, Orator S, Script C

Options (with model numbers)

Cut-sheet feeders	C806481 (Single-bin), C806372 (High-capacity)
Tractor	C800241 (Pull)
Roll-paper holder	N/A
Interfaces	C823061, C823081, C823102, C823132
Ink cartridge	S020010

SQ-870 DIP-switch settings

Country (1-4 OFF)	U.S.	France	Germany	U.K.	Denmark	Sweden	Italy	Spain
1-1	ON	ON	ON	ON	OFF	OFF	OFF	OFF
1-2	ON	ON	OFF	OFF	ON	ON	OFF	OFF
1-3	ON	OFF	ON	OFF	ON	OFF	ON	OFF

Character table (1-4 ON)	PC437	PC850	PC860	PC863	PC865
1-1	ON	ON	ON	ON	OFF
1-2	ON	ON	OFF	OFF	ON
1-3	ON	OFF	ON	OFF	ON

	ON	OFF
1-4	Graphics character tables	Italics character table
1-5	Unidirectional printing only	Bidirectional printing possible
1-6	Not used	Not used
1-7	Not used	Not used
1-8	Not used	Not used

Paper length	11.7 inches	12 inches	8.5 inches	11 inches
2-1	ON	ON	OFF	OFF
2-2	ON	OFF	ON	OFF

	ON	OFF
2-3	1-inch skip-over-perforation	No skip-over perforation
2-4	CR command produces a line feed	CR command does not produce a line feed

Built-in features

Print method	48-nozzle ink jet
Speed	LQ 200 cps @ 10 cpi 240 cps @ 12 cpi Draft 550 cps @ 10 cpi 660 cps @ 12 cpi
Print width	13.6 inches
Paper types	Continuous, Single sheets, Envelopes, Labels, Roll paper
Paper paths	Rear, Top, Front
Tractor	Push
Paper parking	Available
Buffer size	16KB or 128KB
Interface	Parallel
Fonts (typefaces)	Roman, Sans Serif, Courier, Prestige, Script, Orator, Orator S, Script C

Options (with model numbers)

Cut-sheet feeders	C806471 (Single-bin), C806392 (High-capacity)
Tractor	C800231 (Pull)
Roll-paper holder	N/A
Interfaces	C823061, C823081, C823132, C823132
Ink cartridge	S020010

SQ-1170 DIP-switch settings

Country (1-4 OFF)	U.S.	France	Germany	U.K.	Denmark	Sweden	Italy	Spain
1-1	ON	ON	ON	ON	OFF	OFF	OFF	OFF
1-2	ON	ON	OFF	OFF	ON	ON	OFF	OFF
1-3	ON	OFF	ON	OFF	ON	OFF	ON	OFF

Character table (1-4 ON)	PC437	PC850	PC860	PC863	PC865
1-1	ON	ON	ON	ON	OFF
1-2	ON	ON	OFF	OFF	ON
1-3	ON	OFF	ON	OFF	ON

	ON	OFF
1-4	Graphics character tables	Italics character table
1-5	Not used	Not used
1-6	Not used	Not used
1-7	Not used	Not used
1-8	1-inch skip-over-perforation	No skip-over-perforation

Paper length	11.7 inches	12 inches	8.5 inches	11 inches
2-1	ON	ON	OFF	OFF
2-2	ON	OFF	ON	OFF

	ON	OFF
2-3	1-inch skip-over-perforation	No skip-over perforation
2-4	CR command produces a line feed	CR command does not produce a line feed

Built-in features

Print method	24-nozzle ink jet
Speed	LQ 105 cps @ 10 cpi 105 cps @ 12 cpi Draft 176 cps @ 10 cpi 211 cps @ 12 cpi
Print width	13.6 inches
Paper types	Continuous, Single sheets
Paper paths	Rear, Top
Paper parking	Not available
Interface	Parallel
Fonts (typefaces)	N/A
Nonprintable area	22.0 mm at the top of single sheets

Options (with model numbers)

Cut-sheet feeders	#8335 (Single-bin), #8345 (Double-bin)
Tractor	#8302 (Pull)
Interfaces	#8148, #8165, #8172
Ink cartridge	#7750

SQ-2000 DIP-switch settings

Columns	136	109	102	94	80	78	75	65
1-1	ON	ON	ON	ON	OFF	OFF	OFF	OFF
1-2	ON	ON	OFF	OFF	ON	ON	OFF	OFF
1-3	ON	OFF	ON	OFF	ON	OFF	ON	OFF
ON					OFF			
1-4	Cut-sheet feeder mode				No cut-sheet feeder			
Country	U.S.	France	Germany	U.K.	Denmark	Sweden	Italy	Spain
2-1	ON	ON	ON	ON	OFF	OFF	OFF	OFF
2-2	ON	ON	OFF	OFF	ON	ON	OFF	OFF
2-3	ON	OFF	ON	OFF	ON	OFF	ON	OFF
ON					OFF			
2-4	12-inch page length				11-inch page length			
2-5	1-inch skip-over-perforation				No skip-over-perforation			
2-6	Bell disabled				Bell available			
2-7	LQ printing				Draft printing			
2-8	Receive SLCT IN signal				SLCT IN signal ignored			

Built-in features

Print method	24-nozzle ink jet
Speed	LQ 165 cps @ 10 cpi 198 cps @ 12 cpi Draft 450 cps @ 10 cpi 540 cps @ 12 cpi
Print width	8 inches
Paper types	Continuous, Single sheets, Labels
Paper paths	Rear, Top
Paper parking	Not available
Buffer size	8KB
Interfaces	Parallel, Serial
Fonts (typefaces)	Roman, Sans Serif, Courier, Prestige, Script
Nonprintable area	22.0 mm at the top of single sheets

Options (with model numbers)

Cut-sheet feeders	#7342 (Single-bin), #7336 (Double-bin)
Tractor	#7305 (Pull)
Interfaces	#8145, #8148, #8149, #8149M, #8161, #8165, #8172, #8172M
Ink cartridge	#7760

Note:

The SQ-2500 has no DIP switches.

SQ-2550

Year introduced: 1988
Market: Europe, Pacific

Built-in features

Print method	24-nozzle ink jet
Speed	LQ 165 cps @ 10 cpi 198 cps @ 12 cpi Draft 450 cps @ 10 cpi 540 cps @ 12 cpi
Print width	13.6 inches
Paper types	Continuous, Single sheets, Envelopes, Labels
Paper paths	Rear, Top
Tractor	Push
Paper parking	Available
Buffer size	8KB
Interfaces	Parallel, Serial
Fonts (typefaces)	Roman, Sans Serif, Courier, Prestige, Script

Options (with model numbers)

Cut-sheet feeders	C806101 (Single-bin), C806111 (Double-bin)
Tractor	C800042 (Pull)
Interfaces	#8143, #8148, #8165, #8641, #8642
Ink cartridge	S020002

Note:

The SQ-2550 has no DIP switches.

SQ-2550

Year introduced: 1989
Market: Europe, Pacific

Built-in features

Print method	24-nozzle ink jet
Speed	LQ 165 cps @ 10 cpi 198 cps @ 12 cpi
Draft	500 cps @ 10 cpi 600 cps @ 12 cpi
Print width	13.6 inches
Paper types	Continuous, Single sheets, Envelopes, Labels
Paper paths	Rear, Top
Tractor	Push
Paper parking	Available
Buffer size	8KB
Interfaces	Parallel, Serial
Fonts (typefaces)	Roman, Sans Serif, Courier, Prestige, Script, OCR B, OCR A, Orator, Orator S

Options (with model numbers)

Cut-sheet feeders	C806101 (Single-bin), C806111 (Double-bin)
Tractor	C800042 (Pull)
Interfaces	#8143, #8148, #8165, #8641, #8642
Ink cartridge	S020002

Note:

The SQ-2550 has no DIP switches.

Stylus 300

Year introduced: 1993
Market: America, Europe, Pacific

Built-in features

Print method	48-nozzle ink jet
Speed	LQ 110 cps @ 10 cpi 132 cps @ 12 cpi
Print width	8 inches
Paper types	Single sheets, Envelopes
Paper paths	Top, Front
Buffer size	24KB or 8KB
Interface	Parallel
Fonts (typefaces)	Roman, Sans Serif, Roman T, Sans Serif H, Courier, Prestige, Script
Nonprintable area	3.0 mm or 8.5 mm at the top of single sheets (Selectable)

Options (with model numbers)

Ink cartridge	S020031
---------------	---------

Stylus 300 default-setting mode

This printer has no DIP switches; however, the following settings can be made in a special default-setting mode.

Setting	Options
Character table	Italic, PC437, PC437 Greek*, PC850, PC851*, PC852*, PC853*, PC855*, PC857*, PC860, PC863, PC865, PC866*, BRASCII, Abicomp
Auto print direction	On or Off
Auto line feed	On or Off
Network interface mode	On or Off
Mixed text / graphics mode	On or Off
Loading position	3 mm or 8.5 mm

* Availability varies by county.

Built-in features

Print method	48-nozzle ink jet
Speed	LQ 120 cps @ 10 cpi 144 cps @ 12 cpi
Print width	8 inches
Paper types	Single sheets, Envelopes
Paper paths	Top, Front
Buffer size	24KB or 8KB
Interface	Parallel
Fonts (typefaces)	Roman, Sans Serif, Roman T, Sans Serif H, Courier, Prestige
Nonprintable area	3.0 mm or 8.5 mm at the top of single sheets (Selectable)

Options (with model numbers)

Ink cartridge	S020025
---------------	---------

Stylus 400 default-setting mode

This printer has no DIP switches; however, the following settings can be made in a special default-setting mode.

Setting	Options
Character table	Italic, PC437, PC437 Greek*, PC850, PC851*, PC852*, PC853*, PC855*, PC857*, PC860, PC863, PC865, PC866*, PC869*, ISO 8859-7*, ISO Latin 1T*, MAZOWIA*, Code MJK*, Bulgaria*, BRASCII, Abicomp
Auto print direction	On or Off
Auto line feed	On or Off
Network interface mode	On or Off
Mixed text / graphics mode	On or Off
Loading position	3 mm or 8.5 mm

* Availability varies by country.

Built-in features

Print method	48-nozzle ink jet
Speed	LQ 150 cps @ 10 cpi 180 cps @ 12 cpi
Print width	8 inches
Paper types	Single sheets, Envelopes
Paper paths	Top, Front
Buffer size	32KB or 8KB
Interface	Parallel
Fonts (typefaces)	Roman, Sans Serif, Roman T, Sans Serif H, Courier, Prestige, Script
Nonprintable area	3.0 mm at the top of single sheets

Options (with model numbers)

Ink cartridge	S020025
---------------	---------

Stylus 800 default-setting mode

This printer has no DIP switches; however, the following settings can be made in a special default-setting mode.

Setting	Options
Character table	Italic, PC437, PC437 Greek*, PC850, PC851*, PC852*, PC853*, PC855*, PC857*, PC860, PC863, PC865, PC866*, BRASCII, Abicomp
Auto print direction	On or Off
Auto line feed	On or Off
Network interface mode	On or Off
Mixed text / graphics mode	On or Off

* Availability varies by country.

Built-in features

Print method	48-nozzle ink jet
Speed	LQ 165 cps @ 10 cpi 198 cps @ 12 cpi Draft 250 cps @ 10 cpi 300 cps @ 12 cpi
Print width	8 inches
Paper types	Single sheets, Envelopes
Paper paths	Top, Front
Buffer size	32KB or 8KB
Interface	Parallel
Fonts (typefaces)	Roman, Sans Serif, Roman T, Sans Serif H, Courier, Prestige, Script
Nonprintable area	3.0 mm at the top of single sheets

Options (with model numbers)

Ink cartridge	S020025
---------------	---------

Stylus 800+ default-setting mode

This printer has no DIP switches; however, the following settings can be made in a special default-setting mode.

Setting	Options
Character table	Italic, PC437, PC437 Greek*, PC850, PC852*, PC853*, PC855*, PC857*, PC860*, PC863*, PC865*, PC866*, BRASCII*, Abicomp*, MAZOWIA*, Code MJK*, ISO 8859-7, ISO Latin 1T*, Bulgaria*
Auto print direction	On or Off
Network interface mode	On or Off
Mixed text / graphics mode	On or Off
Auto line feed	On or Off

* Availability varies by country.

Built-in features

Print method	48-nozzle ink jet
Speed	LQ 150 cps @ 10 cpi 180 cps @ 12 cpi Draft 250 cps @ 10 cpi 300 cps @ 12 cpi
Print width	8 inches
Paper types	Single sheets, Envelopes
Paper paths	Top, Front
Buffer size	64KB or 128KB
Interface	Parallel
Fonts (typefaces)	Roman, Sans Serif, Roman T, Sans Serif H, Courier, Prestige, Script
Nonprintable area	3.0 mm at the top of single sheets

Options (with model numbers)

Interfaces	C82305*/C82306*, C82307*/C82308*, C82310*, C82313*, C82312*
Push-tractor	C80029*
Ink cartridge	S020025

*The last digit of the option model numbers shown above as an asterisk varies by country.

Stylus 1000 default-setting mode

This printer has no DIP switches; however, the following settings can be made in a special default-setting mode.

Setting	Options
Character table	Italic, PC437, PC437 Greek*, PC850, PC851*, PC852*, PC853*, PC855*, PC857*, PC860, PC863, PC865, PC866*, BRASCII**, Abicom**
Auto print direction	On or Off
Continuous-paper page length	11, 12, 8.5, or 70/6 (A4) inches
Skip-over-perforation	On or Off
Network interface mode	On or Off
Mixed text / graphics mode	On or Off
Auto line feed	On or Off
Auto interface selection	On or Off
Auto interface wait time	30 sec. or 10 sec.
Tear off	On or Off

* Available only in European versions.

** Available only in the American version.

Stylus COLOR

Year introduced: 1994
Market: America, Europe, Pacific

Built-in features

Print method	64-nozzle ink jet (Black) 48-nozzle ink jet (Cyan, Magenta, Yellow)
Speed	LQ 200 cps @ 10 cpi 240 cps @ 12 cpi
Print width	8 inches
Paper types	Single sheets, Envelopes, Transparencies
Paper path	Front
Buffer size	64KB
Interfaces	Parallel, Serial, Option
Fonts (typefaces)	Roman, Sans Serif, Roman T, Sans Serif H, Courier, Prestige, Script
Nonprintable area	3.0 mm or 8.5 mm at the top of single sheets (Selectable)

Options (with model numbers)

Ink cartridges	S020034 (Black), S020036 (Color)
----------------	----------------------------------

Stylus Color default-setting mode

This printer has no DIP switches; however, the following settings can be made in a special default-setting mode.

Setting	Options
Character table	Italic, PC437, PC437 Greek*, PC850, PC851*, PC852*, PC853*, PC855*, PC857*, PC860, PC861, PC863, PC865, PC866*, Abicomp, BRASCII
Auto print direction	Auto, Uni-d, or Bi-d
Auto line feed	On or Off
Network interface mode	On or Off
Loading position	3 mm or 8.5 mm
Interface mode	Auto, Parallel, Serial, or Option
Auto interface wait mode	10 sec. or 30 sec.

* Availability varies by country.

Built-in features

Print method	48-pin impact
Speed	LQ 83 cps @ 10 cpi 100 cps @ 12 cpi Draft 250 cps @ 10 cpi 300 cps @ 12 cpi
Print width	13.6 inches
Paper types	Continuous, Single sheets, Envelopes, Labels
Paper paths	Rear, Top
Tractor	Push
Paper parking	Available
Buffer size	8KB
Interfaces	Parallel, Serial
Fonts (typefaces)	Roman, Sans Serif, Courier, Prestige, Script, OCR B, OCR A, Orator, Orator S

Options (with model numbers)

Cut-sheet feeder	C806001 (Double-bin)
Tractor	C800001 (Pull)
Interfaces	#8143, #8148, #8165
Ribbons	S015001 (Fabric), S015011 (Film)

Note:

The TLQ-4800 has no DIP switches.

Built-in features

Print method	48-nozzle ink jet
Speed	LQ 180 cps @ 10 cpi 216 cps @ 12 cpi Draft 500 cps @ 10 cpi 600 cps @ 12 cpi
Print width	13.6 inches
Paper types	Continuous, Single sheets, Envelopes, Labels
Paper paths	Rear, Top
Tractor	Push
Paper parking	Available
Buffer size	8KB
Interfaces	Parallel, Serial
Fonts (typefaces)	Roman, Sans Serif, Courier, Prestige, Script, OCR B, OCR A, Orator, Orator S

Options (with model numbers)

Cut-sheet feeders	C806101 (Single-bin), C806111 (Double-bin)
Tractor	C800042 (Pull)
Interfaces	#8143, #8148, #8165, #8641, #8642
Ink cartridge	S020002

Note:

The TLQ-4800 has no DIP switches.

9-Pin Printers

ActionPrinter Apex 80

Year introduced: 1988

Market: America

Built-in features

Print method	9-pin impact
Speed	NLQ 25 cps @ 10 cpi 30 cps @ 12 cpi Draft 150 cps @ 10 cpi 180 cps @ 12 cpi
Print width	8 inches
Paper types	Continuous, Single sheets, Envelopes, Roll paper
Multipart forms	Original plus 2 copies
Paper paths	Rear, Top
Tractor	Pull
Paper parking	Not available
Buffer size	3KB
Interface	Parallel
Fonts (typefaces)	Roman, Sans Serif
Nonprintable area	22.0 mm at the top of single sheets

Options (with model numbers)

Cut-sheet feeder	#7341 (Single-bin)
Roll-paper holder	#8310
Interfaces	#8143, #8148, #8165, #8172
Ribbon	#8750 (Fabric)

ActionPrinter Apex 80 DIP-switch settings

	ON				OFF			
1-1	Condensed printing				Noncondensed printing			
1-2	Slashed zero (Ø)				Normal zero (0)			
1-3	Graphics character table				Italics character table			
1-4	Paper-end sensor off				Paper-end sensor on			
1-5	Draft printing				NLQ printing			
Country	U.S.	France	Germany	U.K.	Denmark	Sweden	Italy	Spain
1-6	ON	ON	ON	ON	OFF	OFF	OFF	OFF
1-7	ON	ON	OFF	OFF	ON	ON	OFF	OFF
1-8	ON	OFF	ON	OFF	ON	OFF	ON	OFF
	ON				OFF			
2-1	12-inch page length				11-inch page length			
2-2	Cut-sheet feeder mode on				Cut-sheet feeder mode off			
2-3	1-inch skip-over-perforation				No skip-over-perforation			
2-4	CR command produces a line feed				CR command does not produce a line feed			

Built-in features

Print method	9-pin impact
Speed	NLQ 40 cps @ 10 cpi 48 cps @ 12 cpi Draft 200 cps @ 10 cpi 240 cps @ 12 cpi
Print width	13.6 inches
Paper types	Continuous, Single sheets
Multipart forms	Original plus 2 copies
Paper paths	Rear, Top
Tractor	Pull
Paper parking	Not available
Buffer size	3KB
Interface	Parallel
Fonts (typefaces)	Roman, Sans Serif
Nonprintable area	22.0 mm at the top of single sheets

Options (with model numbers)

Cut-sheet feeder	#8348 (Single-bin)
Interfaces	#8148, #8165, #8172
Ribbon	#8755(M) (Fabric)

ActionPrinter T-750 DIP-switch settings

	ON				OFF			
1-1	Condensed printing				Noncondensed printing			
1-2	Slashed zero (Ø)				Normal zero (0)			
1-3	ESC/P mode: Graphics character table IBM mode: CR produces no line feed				ESC/P mode: Italics character table IBM mode: CR produces line feed			
1-4	IBM mode				ESC/P mode			
1-5	NLQ printing				Draft printing			
Country	U.S.	France	Germany	U.K.	Denmark	Sweden	Italy	Spain
1-6	ON	ON	ON	ON	OFF	OFF	OFF	OFF
1-7	ON	ON	OFF	OFF	ON	ON	OFF	OFF
1-8	ON	OFF	ON	OFF	ON	OFF	ON	OFF
	ON				OFF			
2-1	12-inch page length				11-inch page length			
2-2	Cut-sheet feeder mode on				Cut-sheet feeder mode off			
2-3	1-inch skip-over-perforation				No skip-over-perforation			
2-4	CR command produces a line feed				CR command does not produce a line feed			

Built-in features

Print method	9-pin impact
Speed	NLQ 25 cps @ 10 cpi 30 cps @ 12 cpi Draft 150 cps @ 10 cpi 180 cps @ 12 cpi
Print width	8 inches
Paper types	Continuous, Single sheets, Roll paper
Multipart forms	Original plus 2 copies
Paper paths	Rear, Top
Tractor	Pull
Paper parking	Not available
Buffer size	3KB
Interface	Parallel
Fonts (typefaces)	Roman, Sans Serif
Nonprintable area	22.0 mm at the top of single sheets

Options (with model numbers)

Cut-sheet feeder	#7341 (Single-bin)
Roll-paper holder	#8310
Interfaces	#8143, #8148, #8165
Ribbon	#8750 (Fabric)

ActionPrinter T-1000 DIP-switch settings

	ON				OFF			
1-1	Condensed printing				Noncondensed printing			
1-2	Slashed zero (Ø)				Normal zero (0)			
1-3	Graphics character table				Italics character table			
1-4	Paper-end sensor off				Paper-end sensor on			
1-5	NLQ printing				Draft printing			
Country	U.S.	France	Germany	U.K.	Denmark	Sweden	Italy	Spain
1-6	ON	ON	ON	ON	OFF	OFF	OFF	OFF
1-7	ON	ON	OFF	OFF	ON	ON	OFF	OFF
1-8	ON	OFF	ON	OFF	ON	OFF	ON	OFF
	ON				OFF			
2-1	12-inch page length				11-inch page length			
2-2	Cut-sheet feeder mode on				Cut-sheet feeder mode off			
2-3	1-inch skip-over-perforation				No skip-over-perforation			
2-4	CR command produces a line feed				CR command does not produce a line feed			

Built-in features

Print method	9-pin impact
Speed	NLQ 25 cps @ 10 cpi 30 cps @ 12 cpi Draft 150 cps @ 10 cpi 180 cps @ 12 cpi High-speed draft 200 cps @ 10 cpi
Print width	8 inches
Paper types	Continuous, Single sheets, Envelopes, Labels, Roll paper
Multipart forms	Original plus 2 copies
Paper paths	Rear, Top
Tractor	Push
Paper parking	Available
Buffer size	4KB
Interface	Parallel
Fonts (typefaces)	Roman, Sans Serif

Options (with model numbers)

Cut-sheet feeder	C806121 (Single-bin)
Tractor	C800061 (Pull)
Roll-paper holder	#8310
Interfaces	#8143, #8148, #8165
Ribbon	#8750 (Fabric)

ActionPrinter 2000 DIP-switch settings

	ON				OFF			
1-1	12- cpi printing				10- cpi printing			
1-2	Slashed zero (Ø)				Normal zero (0)			
1-3	Graphics character table				Italics character table			
1-4	Automatic tear-off				No automatic tear-off			
1-5	Normal draft printing				High-speed draft printing			
Country	U.S.	France	Germany	U.K.	Denmark	Sweden	Italy	Spain
1-6	ON	ON	ON	ON	OFF	OFF	OFF	OFF
1-7	ON	ON	OFF	OFF	ON	ON	OFF	OFF
1-8	ON	OFF	ON	OFF	ON	OFF	ON	OFF
	ON				OFF			
2-1	12-inch page length				11-inch page length			
2-2	Cut-sheet feeder mode on				Cut-sheet feeder mode off			
2-3	1-inch skip-over-perforation				No skip-over-perforation			
2-4	CR command produces a line feed				CR command does not produce a line feed			

Built-in features

Print method	9-pin impact
Speed	NLQ 40 cps @ 10 cpi 48 cps @ 12 cpi Draft 200 cps @ 10 cpi 240 cps @ 12 cpi
Print width	8 inches
Paper types	Continuous, Single sheets, Envelopes, Labels
Multipart forms	Original plus 2 copies
Paper paths	Rear, Front
Paper parking	Available
Buffer size	4KB
Interface	Parallel
Fonts (typefaces)	Roman, Sans Serif

Options (with model numbers)

Tractor	C800262 (Push)
Ribbon	S015047 (Fabric)

ActionPrinter 2250 default-setting mode

This printer has no DIP switches; however, the following settings can be made in a special default-setting mode.

Setting	Options
Character table	PC437, PC850, PC860, PC863, PC865, BRASCII, Abicomp
Page length (for continuous paper)	11, 12, 8.5, or 70/6 (A4) inches
Skip-over-perforation	On or Off
Tear-off position	On or Above tear-off edge
Top-of-form position	-3, -2, -1, ±0, 1, 2, 3
Shape of zero	Unslashed (0) or slashed (Ø) zero
Back feed	Enable or Disable
Auto line feed	On or Off
Character pitch	10 or 12 cpi

Built-in features

Print method	9-pin impact
Speed	NLQ 25 cps @ 10 cpi 30 cps @ 12 cpi Draft 150 cps @ 10 cpi 180 cps @ 12 cpi High-speed draft 200 cps @ 10 cpi
Print width	13.6 inches
Paper types	Continuous, Single sheets, Envelopes, Labels
Multipart forms	Original plus 2 copies
Paper paths	Rear, Top
Tractor	Push
Paper parking	Available
Buffer size	4KB
Interface	Parallel
Fonts (typefaces)	Roman, Sans Serif

Options (with model numbers)

Cut-sheet feeder	C806242 (Single-bin)
Tractor	C800142 (Pull)
Interfaces	#8143, #8148, #8165
Ribbon	#8755 (Fabric)

ActionPrinter 2500 DIP-switch settings

Switch	ON	OFF
1-1	12- cpi printing	10- cpi printing
1-2	Slashed zero (Ø)	Normal zero (0)
1-3	Graphics character table	Italics character table
1-4	Automatic tear-off	No automatic tear-off
1-5	Normal draft printing	High-speed draft printing

Country	U.S.	France	Germany	U.K.	Denmark	Sweden	Italy	Spain
1-6	ON	ON	ON	ON	OFF	OFF	OFF	OFF
1-7	ON	ON	OFF	OFF	ON	ON	OFF	OFF
1-8	ON	OFF	ON	OFF	ON	OFF	ON	OFF

	ON	OFF
2-1	12-inch page length	11-inch page length
2-2	Cut-sheet feeder mode on	Cut-sheet feeder mode off
2-3	1-inch skip-over-perforation	No skip-over-perforation
2-4	CR command produces a line feed	CR command does not produce a line feed

Built-in features

Print method	9-pin impact
Speed	NLQ 80 cps @ 10 cpi 96 cps @ 12 cpi Draft 400 cps @ 10 cpi 480 cps @ 12 cpi High-speed draft 533 cps @ 10 cpi
Print width	13.6 inches
Paper types	Continuous, Labels
Multipart forms	Front tractor: original plus 5 copies Rear tractor: original plus 3 copies
Paper paths	Rear, Front
Tractors	Push (front and rear)
Paper parking	Available
Buffer size	3KB
Interfaces	Parallel, Serial
Fonts (typefaces)	Roman, Sans Serif

Options (with model numbers)

Tractor	#8309 (Pull)
Interfaces	#8133W, #8143, #8145, #8148, #8149, #8149M, #8165, #8641, #8642
Ribbon	#8766 (Fabric)

DFX-5000 DIP-switch settings

	ON				OFF			
1-1	Condensed printing				Noncondensed printing			
1-2	Slashed zero (Ø)				Normal zero (0)			
1-3	Graphics character table				Italics character table			
1-4	No buffer				3-KB buffer			
1-5	NLQ printing				Draft printing			
Country	U.S.	France	Germany	U.K.	Denmark	Sweden	Italy	Spain
1-6	ON	ON	ON	ON	OFF	OFF	OFF	OFF
1-7	ON	ON	OFF	OFF	ON	ON	OFF	OFF
1-8	ON	OFF	ON	OFF	ON	OFF	ON	OFF
	ON				OFF			
2-1	12-inch page length				11-inch page length			
2-2	Normal draft printing				High-speed draft printing			
2-3	1-inch skip-over-perforation				No skip-over-perforation			
2-4	CR command produces a line feed				CR command does not produce a line feed			
Interface	Serial (none)		Serial (even)		Serial (odd)		Parallel	
2-5	ON		ON		OFF		OFF	
2-6	ON		OFF		ON		OFF	
Baud	300		1,200		4,800		9,600	
2-7	ON		ON		OFF		OFF	
2-8	ON		OFF		ON		OFF	

Built-in features

Print method	9-pin impact
Speed	NLQ 84 cps @ 10 cpi 101 cps @ 12 cpi Draft 420 cps @ 10 cpi 504 cps @ 12 cpi High-speed draft 560 cps @ 10 cpi
Print width	13.6 inches
Paper types	Continuous, Labels
Multipart forms	Front tractor: original plus 5 copies Rear tractor: original plus 3 copies
Paper paths	Rear, Front
Tractors	Push (front and rear)
Paper parking	Available
Buffer size	20KB, 0KB
Interfaces	Parallel, Serial
Fonts (typefaces)	Roman, Sans Serif

Options (with model numbers)

Tractor	#8309 (Pull)
Interfaces	C82305*/C82306*, C82307*/C82308*, C82310*, C82312*, C82313*, C82314*, C82315*, C82324*
Ribbon	#8766 (Fabric)

*The last digit of the option number shown above as an asterisk varies by country.
Not all interfaces are available in all countries.

DFX-5000+ DIP-switch settings

	ON	OFF
1-1	IBM ProPrinter II emulation mode	EPSON ESC/P mode
1-2	Normal printing	High-speed printing
1-3	NLQ printing	Draft printing
1-4-8	Character table (ESC/P mode)	See table A
1-4-8	Function settings (IBM mode)	See table B

	ON	OFF
2-1	Slashed zero (Ø)	Normal zero (0)
2-2	No buffer	20-KB buffer
2-3 †	Auto line feed on	Auto line feed off

Auto interface selection	Odd parity for serial (wait time: 30 sec.)	Odd parity for serial (wait time: 10 sec.)	No parity for serial (wait time: 30 sec.)	Not parity for serial (wait time: 10 sec.)
2-4	OFF	OFF	OFF	OFF
2-5	OFF	OFF	ON	ON
2-6	OFF	ON	OFF	ON

Interface	Serial (none)	Serial (even)	Serial (odd)	Parallel
2-4	ON	ON	ON	ON
2-5	ON	ON	OFF	OFF
2-6	ON	OFF	ON	OFF

Baud	300	1,200	9,600	19,200
2-7	ON	ON	OFF	OFF
2-8	ON	OFF	ON	OFF

Page length	11 inches	12 inches	8.5 inches	70/6 inches
3-1	OFF	OFF	ON	ON
3-2	OFF	ON	OFF	ON

† This setting is available only in IBM mode.

DFX-5000+ DIP-switch settings (continued)

	ON	OFF
3-3	Skip-over-perforation on	Skip-over-perforation off
3-4	Paper memory setting 2	Paper memory setting 1
3-5	Overlapping multipart forms printing enabled	Overlapping multipart forms printing disabled
3-6	Multipart forms with labels printing enabled	Multipart forms with labels printing disabled
3-7	Skip over binding on	Skip over binding off
3-8	Automatic tear off enabled	Automatic tear off disabled

Table A (EPSON ESC/P mode only)

Character table	1-4	1-5	1-6	1-7	1-8
Italic U.S.A.	OFF	OFF	OFF	OFF	OFF
Italic France	OFF	OFF	OFF	OFF	ON
Italic Germany	OFF	OFF	OFF	ON	OFF
Italic U.K.	OFF	OFF	OFF	ON	ON
Italic Denmark	OFF	OFF	ON	OFF	OFF
Italic Sweden	OFF	OFF	ON	OFF	ON
Italic Italy	OFF	OFF	ON	ON	OFF
Italic Spain	OFF	OFF	ON	ON	ON
PC437	OFF	ON	OFF	OFF	OFF
PC850	OFF	ON	OFF	OFF	ON
PC860	OFF	ON	OFF	ON	OFF
PC863	OFF	ON	OFF	ON	ON
PC865	OFF	ON	ON	OFF	OFF
PC861	OFF	ON	ON	OFF	ON
BRASCII	OFF	ON	ON	ON	OFF
Abicomp	OFF	ON	ON	ON	ON
PC437 Greek*	ON	OFF	OFF	OFF	OFF
PC869*	ON	OFF	OFF	OFF	ON
ISO 8859-7*	ON	OFF	OFF	ON	OFF
PC853*	ON	OFF	OFF	ON	ON
PC857*	ON	OFF	ON	OFF	OFF
ISO Latin 1T*	ON	OFF	ON	OFF	ON
PC855*	ON	OFF	ON	ON	OFF
PC866*	ON	OFF	ON	ON	ON
PC852*	ON	ON	OFF	OFF	OFF
MAZOWIA*	ON	ON	OFF	OFF	ON
Code MJK*	ON	ON	OFF	ON	OFF
Bulgaria	ON	ON	OFF	ON	ON

Table B (IBM ProPrinter emulation mode)

	ON	OFF
1-4	Auto carriage return enabled	Auto carriage return disabled
1-5	—	—
1-6	80–9FH characters printed	80–9FH commands
1-7	—	—
1-8	PC865 character table selected	PC437 character table selected

Built-in features

Print method	9-pin impact
Speed	NLQ 160 cps @ 10 cpi 192 cps @ 12 cpi Draft 800 cps @ 10 cpi 960 cps @ 12 cpi High-speed draft 1066 cps @ 10 cpi
Print width	13.6 inches
Paper types	Continuous, Labels
Multipart forms	Front tractor: original plus 5 copies; Rear tractor: original plus 3 copies
Paper paths	Rear, Front
Tractors	Push (front and rear)
Paper parking	Available
Buffer size	3KB
Interface	Parallel
Fonts (typefaces)	Roman, Sans Serif

Options (with model numbers)

Tractor	#8309 (Pull)
Paper cutter	C81500*
Interfaces	#8143, #8148, #8165, #8641, #8142
Ribbon	#8766 (Fabric)

*The last digit of the option model number shown above as an asterisk varies by country.

DFX-8000 DIP-switch settings

	ON	OFF
1-1	Condensed printing	Noncondensed printing
1-2	Slashed zero (ø)	Normal zero (0)
1-3	ESC/P mode: Graphics char. table; IBM mode: CR = no line feed	ESC/P mode: Italics char. table; IBM mode: CR = line feed
1-4	IBM mode	ESC/P mode
1-5	NLQ printing	Draft printing

Country	U.S.	France	Germany	U.K.	Denmark	Sweden	Italy	Spain
1-6	ON	ON	ON	ON	OFF	OFF	OFF	OFF
1-7	ON	ON	OFF	OFF	ON	ON	OFF	OFF
1-8	ON	OFF	ON	OFF	ON	OFF	ON	OFF

	ON	OFF
2-1	ESC/P mode: User-defined char.; IBM mode: FF command at TOF	ESC/P mode: ROM char.; IBM mode: No FF command at TOF
2-2	Normal draft printing	High-speed draft printing
2-3	7-bit data length	8-bit data length
2-4	CR command produces a line feed	CR command does not produce a line feed

Interface	Serial (none)	Serial (even)	Serial (odd)	Parallel
2-5	ON	ON	OFF	OFF
2-6	ON	OFF	ON	OFF

Baud	300	1,200	4,800	9,600
2-7	ON	ON	OFF	OFF
2-8	ON	OFF	ON	OFF

	ON	OFF
3-1	No buffer	3-KB buffer
3-2	12-inch page length	11-inch page length
3-3	1-inch skip-over-perforation	No skip-over-perforation
3-4	Paper memory 2	Paper memory 1
3-5	Overlapping multipart forms	Non-overlapping multipart forms
3-6	Multipart forms with labels	Multipart forms with no labels
3-7	Skip-over-binding	No skip-over-binding
3-8	XON/XOFF serial protocol	DTR serial protocol

Built-in features

Print method	9-pin impact
Speed	NLQ 50 cps @ 10 cpi 60 cps @ 12 cpi Draft 250 cps @ 10 cpi 300 cps @ 12 cpi
Print width	8 inches
Paper types	Continuous, Single sheets, Labels, Roll paper
Multipart forms	Original plus 2 copies
Paper paths	Rear, Top
Tractor	Push
Paper parking	Not available
Buffer size	8KB
Interfaces	Parallel, Serial
Fonts (typefaces)	Roman, Sans Serif
Nonprintable area	22.0 mm at the top of single sheets

Options (with model numbers)

Cut-sheet feeder	#8342 (Single-bin)
Tractor	#8307 (Pull)
Roll-paper holder	#8310
Interfaces	#8131, #8132(W), #8133, #8143, #8145, #8148, #8149, #8149(M), #8161, #8165, #8172, #8172(M)
Color kits	#8391, #8391P
Scanner kit	#8392
Ribbons	#8763 (Fabric), #8764 (Color)

EX-800 DIP-switch settings

	ON				OFF			
1-1	Condensed printing				Noncondensed printing			
1-2	Slashed zero (Ø)				Normal zero (0)			
1-3	Graphics character table				Italics character table			
1-4	IBM mode				ESC/P mode			
1-5	NLQ printing				Draft printing			
Country	U.S.	France	Germany	U.K.	Denmark	Sweden	Italy	Spain
1-6	ON	ON	ON	ON	OFF	OFF	OFF	OFF
1-7	ON	ON	OFF	OFF	ON	ON	OFF	OFF
1-8	ON	OFF	ON	OFF	ON	OFF	ON	OFF
	ON				OFF			
2-1	12-inch page length				11-inch page length			
2-2	Cut-sheet feeder mode on				Cut-sheet feeder mode off			
2-3	1-inch skip-over-perforation				No skip-over-perforation			
2-4	CR command produces a line feed				CR command does not produce a line feed			
Interface	Serial (none)		Serial (even)		Serial (odd)		Parallel	
2-5	ON		ON		OFF		OFF	
2-6	ON		OFF		ON		OFF	
Baud	300		1,200		4,800		9,600	
2-7	ON		ON		OFF		OFF	
2-8	ON		OFF		ON		OFF	

Built-in features

Print method	9-pin impact
Speed	NLQ 50 cps @ 10 cpi 60 cps @ 12 cpi Draft 250 cps @ 10 cpi 300 cps @ 12 cpi
Print width	13.6 inches
Paper types	Continuous, Single sheets, Labels
Multipart forms	Original plus 2 copies
Paper paths	Rear, Top
Tractor	Push
Paper parking	Not available
Buffer size	8KB
Interfaces	Parallel, Serial
Fonts (typefaces)	Roman, Sans Serif
Nonprintable area	22.0 mm at the top of single sheets

Options (with model numbers)

Cut-sheet feeders	#8343 (Single-bin), #8346 (Double-bin)
Tractor	#8308 (Pull)
Interfaces	#8131, #8132(W), #8133, #8143, #8145, #8148, #8149, 8149(M), #8161, #8165, #8172, #8172(M)
Color kits	#8391, #8391P
Scanner kit	#8392
Ribbons	#8763 (Fabric), #8764 (Color)

EX-1000 DIP-switch settings

	ON				OFF			
1-1	Condensed printing				Noncondensed printing			
1-2	Slashed zero (Ø)				Normal zero (0)			
1-3	Graphics character table				Italics character table			
1-4	IBM mode				ESC/P mode			
1-5	NLQ printing				Draft printing			
Country	U.S.	France	Germany	U.K.	Denmark	Sweden	Italy	Spain
1-6	ON	ON	ON	ON	OFF	OFF	OFF	OFF
1-7	ON	ON	OFF	OFF	ON	ON	OFF	OFF
1-8	ON	OFF	ON	OFF	ON	OFF	ON	OFF
	ON				OFF			
2-1	12-inch page length				11-inch page length			
2-2	Cut-sheet feeder mode on				Cut-sheet feeder mode off			
2-3	1-inch skip-over-perforation				No skip-over-perforation			
2-4	CR command produces a line feed				CR command does not produce a line feed			
Interface	Serial (none)		Serial (even)		Serial (odd)		Parallel	
2-5	ON		ON		OFF		OFF	
2-6	ON		OFF		ON		OFF	
Baud	300		1,200		4,800		9,600	
2-7	ON		ON		OFF		OFF	
2-8	ON		OFF		ON		OFF	

Built-in features

Print method	9-pin impact
Speed	Draft 160 cps @ 10 cpi
Print width	8 inches
Paper types	Continuous, Single sheets, Roll paper
Multipart forms	Original plus 2 copies
Paper paths	Rear, Top
Paper parking	Not available
Buffer size	2KB
Interface	Parallel
Nonprintable area	22.0 mm at the top of single sheets

Options (with model numbers)

Cut-sheet feeder	#8331 (Single-bin)
Tractor	#8300 (Pull)
Roll-paper holder	#8310
Interfaces	#8143, #8165, #8172
Ribbon	#8750 (Fabric)

FX-80 DIP-switch settings

	ON	OFF
1-1	Condensed printing	Noncondensed printing
1-2	Slashed zero (Ø)	Normal zero (0)
1-3	Paper-end sensor off	Paper-end sensor on
1-4	2-KB buffer	No buffer
1-5	Emphasized printing	Normal printing

Country	U.S.	France	Germany	U.K.	Denmark	Sweden	Italy	Spain
1-6	ON	ON	ON	ON	OFF	OFF	OFF	OFF
1-7	ON	ON	OFF	OFF	ON	ON	OFF	OFF
1-8	ON	OFF	ON	OFF	ON	OFF	ON	OFF

	ON	OFF
2-1	Receive SLCT IN signal	SLCT IN signal ignored
2-2	Bell available	Bell disabled
2-3	1-inch skip-over-perforation	No skip-over-perforation
2-4	CR command produces a line feed	CR does not cause line feed

Built-in features

Print method	9-pin impact
Speed	Draft 160 cps @ 10 cpi 96 cps @ 12 cpi
Print width	8 inches
Paper types	Continuous, Single sheets, Roll paper
Multipart forms	Original plus 2 copies
Paper paths	Rear, Top
Paper parking	Not available
Buffer size	2KB
Interface	Parallel
Nonprintable area	22.0 mm at the top of single sheets

Options (with model numbers)

Cut-sheet feeder	#8331 (Single-bin)
Tractor	#8300 (Pull)
Roll-paper holder	#8310
Interfaces	#8120, #8131, #8132, #8143, #8145, #8148, #8149, #8161, #8165, #8171, #8172, #8190
Ribbon	#8750 (Fabric)

FX-80+ DIP-switch settings

	ON	OFF
1-1	Condensed printing	Noncondensed printing
1-2	Slashed zero (Ø)	Normal zero (0)
1-3	Paper-end sensor off	Paper-end sensor on
1-4	2-KB buffer	No buffer
1-5	Emphasized printing	Normal printing

Country	U.S.	France	Germany	U.K.	Denmark	Sweden	Italy	Spain
1-6	ON	ON	ON	ON	OFF	OFF	OFF	OFF
1-7	ON	ON	OFF	OFF	ON	ON	OFF	OFF
1-8	ON	OFF	ON	OFF	ON	OFF	ON	OFF

	ON	OFF
2-1	Receive SLCT IN signal	SLCT IN signal ignored
2-2	Cut-sheet feeder mode on	Cut-sheet feeder mode off
2-3	1-inch skip-over-perforation	No skip-over-perforation
2-4	CR command produces a line feed	CR command does not produce a line feed

Built-in features

Print method	9-pin impact
Speed	Draft 160 cps @ 10 cpi 96 cps @ 12 cpi
Print width	8 inches
Paper types	Continuous, Single sheets, Roll paper
Multipart forms	Original plus 2 copies
Paper paths	Rear, Top
Paper parking	Not available
Buffer size	8KB
Interface	Parallel
Font (typeface)	Roman
Nonprintable area	22.0 mm at the top of single sheets

Options (with model numbers)

Cut-sheet feeder	#8331 (Single-bin)
Tractor	#8300 (Pull)
Roll-paper holder	#8310
Interfaces	#8120, #8131, #8132, #8132(W), #8133, #8143, #8145, #8148, #8149, #8149(M), #8161, #8165, #8172, #8172(M)
Ribbon	#8750 (Fabric)

FX-85 DIP-switch settings

	ON	OFF
1-1	Condensed printing	Noncondensed printing
1-2	Slashed zero (Ø)	Normal zero (0)
1-3	Paper-end sensor off	Paper-end sensor on
1-4	ESC/P mode	IBM mode
1-5	Emphasized printing	Normal printing

Country	U.S.	France	Germany	U.K.	Denmark	Sweden	Italy	Spain
1-6	ON	ON	ON	ON	OFF	OFF	OFF	OFF
1-7	ON	ON	OFF	OFF	ON	ON	OFF	OFF
1-8	ON	OFF	ON	OFF	ON	OFF	ON	OFF

	ON	OFF
2-1	Receive <u>SLCT IN</u> signal	<u>SLCT IN</u> signal ignored
2-2	Cut-sheet feeder mode on	Cut-sheet feeder mode off
2-3	1-inch skip-over-perforation	No skip-over-perforation
2-4	CR command produces a line feed	CR command does not produce a line feed

Built-in features

Print method	9-pin impact
Speed	NLQ 40 cps @ 10 cpi 48 cps @ 12 cpi Draft 200 cps @ 10 cpi 240 cps @ 12 cpi
Print width	8 inches
Paper types	Continuous, Single sheets
Multipart forms	Original plus 2 copies
Paper paths	Rear, Top
Tractor	Pull
Paper parking	Not available
Buffer size	3KB
Interface	Parallel
Fonts (typefaces)	Roman, Sans Serif
Nonprintable area	22.0 mm at the top of single sheets

Options (with model numbers)

Cut-sheet feeder	#8348 (Single-bin)
Tractor	#8307 (Pull)
Interfaces	#8148, #8172
Ribbon	#8755(M) (Fabric)

FX-86e DIP-switch settings

	ON				OFF			
1-1	Condensed printing				Noncondensed printing			
1-2	Slashed zero (Ø)				Normal zero (0)			
1-3	ESC/P mode: Graphics character table IBM mode: CR produces no line feed				ESC/P mode: Italics character table IBM mode: CR produces line feed			
1-4	IBM mode				ESC/P mode			
1-5	NLQ printing				Draft printing			
Country	U.S.	France	Germany	U.K.	Denmark	Sweden	Italy	Spain
1-6	ON	ON	ON	ON	OFF	OFF	OFF	OFF
1-7	ON	ON	OFF	OFF	ON	ON	OFF	OFF
1-8	ON	OFF	ON	OFF	ON	OFF	ON	OFF
	ON				OFF			
2-1	12-inch page length				11-inch page length			
2-2	Cut-sheet feeder mode on				Cut-sheet feeder mode off			
2-3	1-inch skip-over-perforation				No skip-over-perforation			
2-4	CR command produces a line feed				CR command does not produce a line feed			

Built-in features

Print method	9-pin impact
Speed	Draft 160 cps @ 10 cpi
Print width	13.6 inches
Paper types	Continuous, Single sheets
Multipart forms	Original plus 2 copies
Paper paths	Rear, Top
Paper parking	Not available
Buffer size	2KB
Interface	Parallel
Nonprintable area	22.0 mm at the top of single sheets

Options (with model numbers)

Cut-sheet feeder	#8334 (Single-bin)
Tractor	#8301 (Pull)
Interfaces	#8145, #8172
Ribbon	#8755 (Fabric)

FX-100 DIP-switch settings

	ON	OFF
1-1	Condensed printing	Noncondensed printing
1-2	Slashed zero (Ø)	Normal zero (0)
1-3	Paper-end sensor off	Paper-end sensor on
1-4	2-KB buffer	No buffer
1-5	Emphasized printing	Normal printing

Country	U.S.	France	Germany	U.K.	Denmark	Sweden	Italy	Spain
1-6	ON	ON	ON	ON	OFF	OFF	OFF	OFF
1-7	ON	ON	OFF	OFF	ON	ON	OFF	OFF
1-8	ON	OFF	ON	OFF	ON	OFF	ON	OFF

	ON	OFF
2-1	Receive SLCT IN signal	SLCT IN signal ignored
2-2	Bell available	Bell disabled
2-3	1-inch skip-over-perforation	No skip-over-perforation
2-4	CR command produces a line feed	CR command does not produce a line feed

Built-in features

Print method	9-pin impact	
Speed	Draft 160 cps @ 10 cpi	96 cps @ 12 cpi
Print width	13.6 inches	
Paper types	Continuous, Single sheets	
Multipart forms	Original plus 2 copies	
Paper paths	Rear, Top	
Tractor	Pull	
Paper parking	Not available	
Buffer size	2KB	
Interface	Parallel	
Nonprintable area	22.0 mm at the top of single sheets	

Options (with model numbers)

Cut-sheet feeder	#8333 (Single-bin)
Interfaces	#8120, #8131, #8132, #8143, #8145, #8148, #8149, #8161, #8165, #8171, #8172, #8190
Ribbon	#8755 (Fabric)

FX-100+ DIP-switch settings

	ON	OFF
1-1	Condensed printing	Noncondensed printing
1-2	Slashed zero (Ø)	Normal zero (0)
1-3	Paper-end sensor off	Paper-end sensor on
1-4	2-KB buffer	No buffer
1-5	Emphasized printing	Normal printing

Country	U.S.	France	Germany	U.K.	Denmark	Sweden	Italy	Spain
1-6	ON	ON	ON	ON	OFF	OFF	OFF	OFF
1-7	ON	ON	OFF	OFF	ON	ON	OFF	OFF
1-8	ON	OFF	ON	OFF	ON	OFF	ON	OFF

	ON	OFF
2-1	Receive SLCT IN signal	SLCT IN signal ignored
2-2	Cut-sheet feeder mode on	Cut-sheet feeder mode off
2-3	1-inch skip-over-perforation	No skip-over-perforation
2-4	CR command produces a line feed	CR command does not produce a line feed

Built-in features

Print method	9-pin impact
Speed	NLQ 32 cps @ 10 cpi Draft 160 cps @ 10 cpi 96 cps @ 12 cpi
Print width	13.6 inches
Paper types	Continuous, Single sheets
Multipart forms	Original plus 2 copies
Paper paths	Rear, Top
Tractor	Pull
Paper parking	Not available
Buffer size	8KB
Interface	Parallel
Font (typeface)	Roman
Nonprintable area	22.0 mm at the top of single sheets

Options (with model numbers)

Cut-sheet feeder	#8334 (Single-bin)
Interfaces	#8120, #8131, #8132, #8132(W), #8133, #8143, #8145, #8148, #8149, #8149(M), #8161, #8165, #8172, #8172(M)
Ribbon	#8755 (Fabric)

FX-185 DIP-switch settings

	ON	OFF
1-1	Condensed printing	Noncondensed printing
1-2	Slashed zero (Ø)	Normal zero (0)
1-3	Paper-end sensor off	Paper-end sensor on
1-4	ESC/P mode	IBM mode
1-5	Emphasized printing	Normal printing

Country	U.S.	France	Germany	U.K.	Denmark	Sweden	Italy	Spain
1-6	ON	ON	ON	ON	OFF	OFF	OFF	OFF
1-7	ON	ON	OFF	OFF	ON	ON	OFF	OFF
1-8	ON	OFF	ON	OFF	ON	OFF	ON	OFF

	ON	OFF
2-1	Receive SLCT IN signal	SLCT IN signal ignored
2-2	Cut-sheet feeder mode on	Cut-sheet feeder mode off
2-3	1-inch skip-over-perforation	No skip-over-perforation
2-4	CR command produces a line feed	CR command does not produce a line feed

Built-in features

Print method	9-pin impact
Speed	NLQ 40 cps @ 10 cpi 48 cps @ 12 cpi Draft 200 cps @ 10 cpi 240 cps @ 12 cpi
Print width	13.6 inches
Paper types	Continuous, Single sheets, Labels
Multipart forms	Original plus 2 copies
Paper paths	Rear, Top
Tractor	Pull
Paper parking	Not available
Buffer size	8KB
Interface	Parallel
Font (typeface)	Roman
Nonprintable area	22.0 mm at the top of single sheets

Options (with model numbers)

Cut-sheet feeder	#8334 (Single-bin)
Interfaces	#8148, #8165, #8172
Ribbon	#8755 (Fabric)

FX-286 DIP-switch settings

	ON	OFF
1-1	Condensed printing	Noncondensed printing
1-2	Slashed zero (Ø)	Normal zero (0)
1-3	Paper-end sensor off	Paper-end sensor on
1-4	ESC/P mode	IBM mode
1-5	Emphasized printing	Normal printing

Country	U.S.	France	Germany	U.K.	Denmark	Sweden	Italy	Spain
1-6	ON	ON	ON	ON	OFF	OFF	OFF	OFF
1-7	ON	ON	OFF	OFF	ON	ON	OFF	OFF
1-8	ON	OFF	ON	OFF	ON	OFF	ON	OFF

	ON	OFF
2-1	Receive SLCT IN signal	SLCT IN signal ignored
2-2	Cut-sheet feeder mode on	Cut-sheet feeder mode off
2-3	1-inch skip-over-perforation	No skip-over-perforation
2-4	CR command produces a line feed	CR command does not produce a line feed

Built-in features

Print method	9-pin impact	
Speed	LQ 40 cps @ 10 cpi	48 cps @ 12 cpi
	Draft 200 cps @ 10 cpi	240 cps @ 12 cpi
Print width	13.6 inches	
Paper types	Continuous, Single sheets	
Multipart forms	Original plus 2 copies	
Paper paths	Rear, Top	
Tractor	Pull	
Paper parking	Not available	
Buffer size	3KB	
Interface	Parallel	
Fonts (typefaces)	Roman, Sans Serif	
Nonprintable area	22.0 mm at the top of single sheets	

Options (with model numbers)

Cut-sheet feeder	#8348 (Single-bin)
Tractor	#8308 (Pull)
Interfaces	#8148, #8165, #8172
Ribbon	#8755(M) (Fabric)

FX-286e DIP-switch settings

	ON	OFF
1-1	Condensed printing	Noncondensed printing
1-2	Slashed zero (Ø)	Normal zero (0)
1-3	ESC/P mode: Graphics character table IBM mode: CR produces no line feed	ESC/P mode: Italics character table IBM mode: CR produces line feed
1-4	IBM mode	ESC/P mode
1-5	NLQ printing	Draft printing

Country	U.S.	France	Germany	U.K.	Denmark	Sweden	Italy	Spain
1-6	ON	ON	ON	ON	OFF	OFF	OFF	OFF
1-7	ON	ON	OFF	OFF	ON	ON	OFF	OFF
1-8	ON	OFF	ON	OFF	ON	OFF	ON	OFF

	ON	OFF
2-1	12-inch page length	11-inch page length
2-2	Cut-sheet feeder mode on	Cut-sheet feeder mode off
2-3	1-inch skip-over-perforation	No skip-over-perforation
2-4	CR command produces a line feed	CR command does not produce a line feed

Built-in features

Print method	9-pin impact
Speed	NLQ 40 cps @ 10 cpi 48 cps @ 12 cpi Draft 200 cps @ 10 cpi 240 cps @ 12 cpi
Print width	8 inches
Paper types	Continuous, Single sheets
Multipart forms	Original plus 2 copies
Paper paths	Rear, Top
Tractor	Pull
Paper parking	Not available
Buffer size	3KB
Interface	Parallel
Fonts (typefaces)	Roman, Sans Serif
Nonprintable area	22.0 mm at the top of single sheets

Options (with model numbers)

Cut-sheet feeder	#8348 (Single-bin)
Interfaces	#8148, #8165, #8172
Ribbon	#8755(M) (Fabric)

FX-800 DIP-switch settings

Switch	ON				OFF			
1-1	Condensed printing				Noncondensed printing			
1-2	Slashed zero (Ø)				Normal zero (0)			
1-3	ESC/P mode: Graphics character table IBM mode: CR produces no line feed				ESC/P mode: Italics character table IBM mode: CR produces line feed			
1-4	IBM mode				ESC/P mode			
1-5	NLQ printing				Draft printing			

Country	U.S.	France	Germany	U.K.	Denmark	Sweden	Italy	Spain
1-6	ON	ON	ON	ON	OFF	OFF	OFF	OFF
1-7	ON	ON	OFF	OFF	ON	ON	OFF	OFF
1-8	ON	OFF	ON	OFF	ON	OFF	ON	OFF

	ON				OFF			
2-1	12-inch page length				11-inch page length			
2-2	Cut-sheet feeder mode on				Cut-sheet feeder mode off			
2-3	1-inch skip-over-perforation				No skip-over-perforation			
2-4	CR command produces a line feed				CR command does not produce a line feed			

Built-in features

Print method	9-pin impact
Speed	NLQ 45 cps @ 10 cpi 54 cps @ 12 cpi Draft 220 cps @ 10 cpi 264 cps @ 12 cpi
Print width	8 inches
Paper types	Continuous, Single sheets, Roll paper
Multipart forms	Original plus 3 copies
Paper paths	Rear, Top
Tractor	Push
Paper parking	Available
Buffer size	8KB
Interfaces	Parallel, Serial
Fonts (typefaces)	Roman, Sans Serif

Options (with model numbers)

Cut-sheet feeder	#7339 (Single-bin)
Tractor	#7311 (Pull)
Roll-paper holder	#8310
Interfaces	#8133(W), #8143, #8145, #8148, #8149, #8149M, #8165, #8172
Ribbon	#8750 (Fabric)

FX-850 DIP-switch settings

	ON				OFF			
1-1	User-defined characters				ROM characters			
1-2	Slashed zero (Ø)				Normal zero (0)			
1-3	Graphics character table				Italics character table			
1-4	IBM mode				ESC/P mode			
1-5	No automatic tear-off				Automatic tear-off			
Country	U.S.	France	Germany	U.K.	Denmark	Sweden	Italy	Spain
1-6	ON	ON	ON	ON	OFF	OFF	OFF	OFF
1-7	ON	ON	OFF	OFF	ON	ON	OFF	OFF
1-8	ON	OFF	ON	OFF	ON	OFF	ON	OFF
	ON				OFF			
2-1	12-inch page length				11-inch page length			
2-2	Cut-sheet feeder mode on				Cut-sheet feeder mode off			
2-3	1-inch skip-over-perforation				No skip-over-perforation			
2-4	CR command produces a line feed				CR command does not produce a line feed			

Built-in features

Print method	9-pin impact
Speed	NLQ 45 cps @ 10 cpi 54 cps @ 12 cpi Draft 220 cps @ 10 cpi 264 cps @ 12 cpi High-speed draft 290 cps @ 10 cpi
Print width	8 inches
Paper types	Continuous, Single sheets
Multipart forms	Original plus 3 copies
Paper paths	Rear, Top
Tractor	Push
Paper parking	Available
Buffer size	8KB
Interface	Parallel
Fonts (typefaces)	Roman, Sans Serif

Options (with model numbers)

Cut-sheet feeders	#7339 (Single-bin), #7346 (Double-bin)
Tractor	#7311 (Pull)
Roll-paper holder	#8310
Interfaces	#8143, #8148, #8165
Ribbon	#8750 (Fabric)

FX-850 DIP-switch settings

	ON				OFF			
1-1	User-defined characters				ROM characters			
1-2	Slashed zero (Ø)				Normal zero (0)			
1-3	Graphics character table				Italics character table			
1-4	IBM mode				ESC/P mode			
1-5	No automatic tear-off				Automatic tear-off			
Country	U.S.	France	Germany	U.K.	Denmark	Sweden	Italy	Spain
1-6	ON	ON	ON	ON	OFF	OFF	OFF	OFF
1-7	ON	ON	OFF	OFF	ON	ON	OFF	OFF
1-8	ON	OFF	ON	OFF	ON	OFF	ON	OFF
	ON				OFF			
2-1	12-inch page length				11-inch page length			
2-2	Cut-sheet feeder mode on				Cut-sheet feeder mode off			
2-3	1-inch skip-over-perforation				No skip-over-perforation			
2-4	CR command produces a line feed				CR command does not produce a line feed			

Built-in features

Print method	9-pin impact	
Speed	NLQ	45 cps @ 10 cpi 54 cps @ 12 cpi
	Draft	220 cps @ 10 cpi 264 cps @ 12 cpi
	High-speed draft	290 cps @ 10 cpi
Print width	8 inches	
Paper types	Continuous, Single sheets	
Multipart forms	Original plus 3 copies	
Paper paths	Rear, Top	
Tractor	Push	
Paper parking	Available	
Buffer size	8KB	
Interface	Parallel	
Fonts (typefaces)	Roman, Sans Serif	

Options (with model numbers)

Cut-sheet feeders	#7339 (Single-bin), #7346 (Double-bin)
Tractor	#7311 (Pull)
Roll-paper holder	#8310
Interfaces	#8143, #8148, #8165
Ribbon	#8750 (Fabric)

FX-850 DIP-switch settings

	ON				OFF			
1-1	User-defined characters				ROM characters			
1-2	Slashed zero (Ø)				Normal zero (0)			
1-3	Graphics character tables				Italics character table			
Paper length	11.7 inches		12 inches		8.5 inches		11 inches	
1-4	ON		ON		OFF		OFF	
1-5	ON		OFF		ON		OFF	
Country (1-3 OFF)	U.S.	France	Germany	U.K.	Denmark	Sweden	Italy	Spain
1-6	ON	ON	ON	ON	OFF	OFF	OFF	OFF
1-7	ON	ON	OFF	OFF	ON	ON	OFF	OFF
1-8	ON	OFF	ON	OFF	ON	OFF	ON	OFF
Character table (1-3 ON)	PC437		PC850		PC860		PC865	
1-6	ON		ON		ON		OFF	
1-7	ON		ON		OFF		ON	
1-8	ON		OFF		ON		ON	
	ON				OFF			
2-1	IBM mode				ESC/P mode			
2-2	Cut-sheet feeder mode on				Cut-sheet feeder mode off			
2-3	1-inch skip-over-perforation				No skip-over-perforation			
2-4	CR command produces a line feed				CR command does not produce a line feed			

Built-in features

Print method	9-pin impact
Speed	NLQ 57 cps @ 10 cpi 68 cps @ 12 cpi Draft 285 cps @ 10 cpi 342 cps @ 12 cpi High-speed draft 380 cps @ 10 cpi
Print width	8 inches
Paper types	Continuous, Single sheets, Envelopes, Labels, Roll paper
Multipart forms	Original plus 3 copies
Paper paths	Rear, Bottom, Front
Tractor	Push
Paper parking	Available
Buffer size	24KB or 0KB
Interface	Parallel
Fonts (typefaces)	Roman, Sans Serif

Options (with model numbers)

Cut-sheet feeders	C80637* (Single-bin), C80638* (High-capacity)
Tractor	C80020* (Pull)
Roll-paper holder	#8310
Interfaces	C823051, C823061, C823131, C823081, C823101, C823102, C823131, C823132
Ribbon	#8750 (Fabric)

*The last digit of the option model number shown above as an asterisk varies by country.

FX-870 settings

This printer has no DIP switches; however, the following settings can be made in a special Default-Setting mode.

Setting	Options
Character table	PC437, PC437 Greek*, PC850, PC851*, PC852*, PC853*, PC855*, PC857*, PC860, PC861*, PC863, PC864*, PC865, PC866*, PC869*, U.S.S.R. GOST*, BRASCI1**, Abicomp**
Page length (for continuous paper)	11, 12, 8.5, or 70/6 (A4) inches
Skip-over-perforation	On or Off
Automatic tear-off	On or Off
Printer mode	EPSON ESC/P or IBM
Shape of zero	Normal zero (0) or Slashed zero (Ø)
Buffer	Enable or Disable
Draft print speed	Normal or High
Auto carriage return	Valid or Invalid †
Auto line feed	On or Depends on interface
Character pitch	10 or 12 cpi

* These tables are only available on the European version.

** These tables are only available on the American version.

† This setting is available only in IBM mode.

Built-in features

Print method	9-pin impact
Speed	NLQ 40 cps @ 10 cpi 48 cps @ 12 cpi Draft 200 cps @ 10 cpi 240 cps @ 12 cpi
Print width	13.6 inches
Paper types	Continuous, Single sheets
Multipart forms	Original plus 2 copies
Paper paths	Rear, Top
Tractors	Pull
Paper parking	Not available
Buffer size	3KB
Interface	Parallel
Fonts (typefaces)	Roman, Sans Serif
Nonprintable area	22.0 mm at the top of single sheets

Options (with model numbers)

Cut-sheet feeder	#8348 (Single-bin)
Interfaces	#8148, #8165, #8172
Ribbon	#8755(M) (Fabric)

FX-1000 DIP-switch settings

	ON				OFF			
1-1	Condensed printing				Noncondensed printing			
1-2	Slashed zero (Ø)				Normal zero (0)			
1-3	ESC/P mode: Graphics character table IBM mode: CR produces no line feed				ESC/P mode: Italics character table IBM mode: CR produces line feed			
1-4	IBM mode				ESC/P mode			
1-5	NLQ printing				Draft printing			
Country	U.S.	France	Germany	U.K.	Denmark	Sweden	Italy	Spain
1-6	ON	ON	ON	ON	OFF	OFF	OFF	OFF
1-7	ON	ON	OFF	OFF	ON	ON	OFF	OFF
1-8	ON	OFF	ON	OFF	ON	OFF	ON	OFF
	ON				OFF			
2-1	12-inch page length				11-inch page length			
2-2	Cut-sheet feeder mode on				Cut-sheet feeder mode off			
2-3	1-inch skip-over-perforation				No skip-over-perforation			
2-4	CR command produces a line feed				CR command does not produce a line feed			

Built-in features

Print method	9-pin impact
Speed	NLQ 45 cps @ 10 cpi 54 cps @ 12 cpi Draft 220 cps @ 10 cpi 264 cps @ 12 cpi
Print width	13.6 inches
Paper types	Continuous, Single sheets
Multipart forms	Original plus 3 copies
Paper paths	Rear, Top
Tractor	Push
Paper parking	Available
Buffer size	8KB
Interface	Parallel
Fonts (typefaces)	Roman, Sans Serif
Nonprintable area	22.0 mm at the top of single sheets

Options (with model numbers)

Cut-sheet feeder	#7340 (Single-bin)
Tractor	#7312 (Pull)
Interfaces	#8133(W), #8143, #8145, #8148, #8149, #8149M, #8165, #8172
Ribbon	#8755 (Fabric)

FX-1050 DIP-switch settings

	ON				OFF			
1-1	User-defined characters				ROM characters			
1-2	Slashed zero (Ø)				Normal zero (0)			
1-3	Graphics character table				Italics character table			
1-4	IBM mode				ESC/P mode			
1-5	No automatic tear-off				Automatic tear-off			
Country	U.S.	France	Germany	U.K.	Denmark	Sweden	Italy	Spain
1-6	ON	ON	ON	ON	OFF	OFF	OFF	OFF
1-7	ON	ON	OFF	OFF	ON	ON	OFF	OFF
1-8	ON	OFF	ON	OFF	ON	OFF	ON	OFF
	ON				OFF			
2-1	12-inch page length				11-inch page length			
2-2	Cut-sheet feeder mode on				Cut-sheet feeder mode off			
2-3	1-inch skip-over-perforation				No skip-over-perforation			
2-4	CR command produces a line feed				CR command does not produce a line feed			

Built-in features

Print method	9-pin impact
Speed	NLQ 45 cps @ 10 cpi 54 cps @ 12 cpi Draft 220 cps @ 10 cpi 264 cps @ 12 cpi High-speed draft 290 cps @ 10 cpi
Print width	13.6 inches
Paper types	Continuous, Single sheets
Multipart forms	Original plus 3 copies
Paper paths	Rear, Top
Tractor	Push
Paper parking	Available
Buffer size	8KB
Interface	Parallel
Fonts (typefaces)	Roman, Sans Serif

Options (with model numbers)

Cut-sheet feeders	#7340 (Single-bin), #7348 (Double-bin)
Tractor	#7312 (Pull)
Interfaces	#8143, #8148, #8165
Ribbon	#8755 (Fabric)

FX-1050 DIP-switch settings

	ON				OFF			
1-1	User-defined characters				ROM characters			
1-2	Slashed zero (Ø)				Normal zero (0)			
1-3	Graphics character table				Italics character table			
1-4	IBM mode				ESC/P mode			
1-5	No automatic tear-off				Automatic tear-off			
Country	U.S.	France	Germany	U.K.	Denmark	Sweden	Italy	Spain
1-6	ON	ON	ON	ON	OFF	OFF	OFF	OFF
1-7	ON	ON	OFF	OFF	ON	ON	OFF	OFF
1-8	ON	OFF	ON	OFF	ON	OFF	ON	OFF
	ON				OFF			
2-1	12-inch page length				11-inch page length			
2-2	Cut-sheet feeder mode on				Cut-sheet feeder mode off			
2-3	1-inch skip-over-perforation				No skip-over-perforation			
2-4	CR command produces a line feed				CR command does not produce a line feed			

Built-in features

Print method	9-pin impact
Speed	NLQ 45 cps @ 10 cpi 54 cps @ 12 cpi Draft 220 cps @ 10 cpi 264 cps @ 12 cpi High-speed draft 290 cps @ 10 cpi
Print width	13.6 inches
Paper types	Continuous, Single sheets
Multipart forms	Original plus 3 copies
Paper paths	Rear, Top
Tractor	Push
Paper parking	Available
Buffer size	8KB
Interface	Parallel
Fonts (typefaces)	Roman, Sans Serif

Options (with model numbers)

Cut-sheet feeders	#7340 (Single-bin), #7348 (Double-bin)
Tractor	#7312 (Pull)
Interfaces	#8143, #8148, #8165
Ribbon	#8755 (Fabric)

FX-1050 DIP-switch settings

	ON		OFF					
1-1	User-defined characters		ROM characters					
1-2	Slashed zero (Ø)		Normal zero (0)					
1-3	Graphics character tables		Italics character table					
Paper length	11.7 inches	12 inches	8.5 inches	11 inches				
1-4	ON	ON	OFF	OFF				
1-5	ON	OFF	ON	OFF				
Country 1-3 OFF	U.S.	France	Germany	U.K.	Denmark	Sweden	Italy	Spain
1-6	ON	ON	ON	ON	OFF	OFF	OFF	OFF
1-7	ON	ON	OFF	OFF	ON	ON	OFF	OFF
1-8	ON	OFF	ON	OFF	ON	OFF	ON	OFF
Character table 1-3 ON	PC437	PC850	PC860	PC863	PC865			
1-6	ON	ON	ON	ON	ON			OFF
1-7	ON	ON	OFF	OFF	OFF			ON
1-8	ON	OFF	OFF	ON	OFF			ON
	ON		OFF					
2-1	IBM mode		ESC/P mode					
2-2	Cut-sheet feeder mode on		Cut-sheet feeder mode off					
2-3	1-inch skip-over-perforation		No skip-over-perforation					
2-4	CR command produces a line feed		CR command does not produce a line feed					

Built-in features

Print method	9-pin impact
Speed	NLQ 57 cps @ 10 cpi 68 cps @ 12 cpi Draft 285 cps @ 10 cpi 342 cps @ 12 cpi High-speed draft 380 cps @ 10 cpi
Print width	13.6 inches
Paper types	Continuous, Single sheets, Envelopes, Labels
Multipart forms	Original plus 3 copies
Paper paths	Rear, Bottom, Front
Tractor	Push
Paper parking	Available
Buffer size	24KB or 0KB
Interface	Parallel
Fonts (typefaces)	Roman, Sans Serif

Options (with model numbers)

Cut-sheet feeders	C80639* (Single-bin), C80640* (High-capacity)
Tractor	C80021* (Pull)
Front sheet guide	C814011
Interfaces	C823051, C823061, C823071, C823081, C823101, C823102, C823131, C823132
Ribbon	8755 (Fabric)

*The last digit of the option model number shown above as an asterisk varies by country.

FX-1170 default-setting mode

This printer has no DIP switches; however, the following settings can be made in a special default-setting mode.

Setting	Options
Character table	PC437, PC437 Greek*, PC850, PC851*, PC852*, PC853*, PC855*, PC857*, PC860, PC861*, PC863, PC864*, PC865, PC866*, PC869*, U.S.S.R. GOST*, BRASCI1**, Abicomp**
Page length (for continuous paper)	11, 12, 8.5, or 70/6 (A4) inches
Skip-over-perforation	On or Off
Automatic tear-off	On or Off
Printer mode	EPSON ESC/P or IBM
Shape of zero	Normal zero (0) or Slashed zero (Ø)
Buffer	Enable or Disable
Draft print speed	Normal or High
Auto carriage return	Valid or Invalid †
Auto line feed	On or Depends on interface
Character pitch	10 or 12 cpi

* Availability varies by country.

** These tables are only available on the American version.

† This setting is available only in IBM mode.

Built-in features

Print method	18-pin impact
Speed	NLQ 66 cps @ 10 cpi 79 cps @ 12 cpi Draft 330 cps @ 10 cpi 396 cps @ 12 cpi High-speed draft 440 cps @ 10 cpi
Print width	13.6 inches
Paper types	Continuous, Single sheets, Envelopes, Labels, Cards, Roll paper
Multipart forms	Original plus 5 copies
Paper paths	Rear, Bottom, Front
Tractor	Push, Pull
Paper parking	Available
Buffer size	64KB or 0KB
Interface	Parallel
Fonts (typefaces)	Roman, Sans Serif
Bar codes	EAN-13, EAN-8, Interleaved 2 of 5, UPC-A, UPC-E, Code 39, Code 128, POSTNET
Nonprintable area	4.2 mm at the top and bottom of single sheets

Options (with model numbers)

Cut-sheet feeders	C80673* (High-capacity), C80674* (Second-bin)
Pull tractor unit	C80032*
Roll paper holder	#8310
Interfaces	C82305*, C82306*, C82307*, C82308*, C82310*, C82311*, C82312*, C82313*, C82314*, C82315*, C82331*
Ribbon	S015085 (Cartridge), S010032 (Pack)

*The last digit of the option model number shown above as an asterisk varies by country.

FX-2170 default-setting mode

This printer has no DIP switches; however, the following settings can be made in a special default-setting mode.

Setting	Options
Page length for front tractor	3, 3.5, 4, 5.5, 6, 7, 8, 8.5, 11, 70/6, 12, 14, 17, or Others inches
Page length for rear tractor	3, 3.5, 4, 5.5, 6, 7, 8, 8.5, 11, 70/6, 12, 14, 17, or Others inches
Skip-over-perforation	On or Off
Auto tear off	On or Off
Auto line feed	On or Off †
Print direction	Bi-d or Uni-d
I/F mode	Auto, Parallel, or Option
Auto I/F wait time	10 or 30 sec.
Software	ESC/P or IBM 2381 Plus
Character table	Italic, PC437, PC437 Greek*, PC774*, PC850, PC852*, PC853*, PC855*, PC857*, PC860, PC861, PC863, PC865, PC866*, PC866 LAT*, PC869*, BRASCII, Abicomp, Roman 8, ISO Latin 1, ISO 8859-2*, MAZOWIA*, Code MJK*, ISO 8859-7*, ISO Latin 1T*, Bulgaria*, Estonia*
International character set	U.S.A., France, Germany, U.K., Denmark 1, Sweden, Italy, Spain 1
0 slash	0 or Ø
High speed draft	On or Off
Input buffer	On or Off
Buzzer	On or Off
Auto CR	On or Off †
IBM character table	Table 1 or Table 2 †

* Availability varies by country.

† This setting is available only in IBM mode.

HS-80

Year introduced: 1985
Market: America, Europe, Pacific

Built-in features

Print method	9-element ink jet
Print width	8 inches
Paper types	Single sheets, Roll paper
Paper paths	Top
Paper parking	Not available
Buffer size	One line
Interface	Parallel
Font (typeface)	Roman
Nonprintable area	22.0 mm at the top of single sheets

Options (with model numbers)

Roll-paper holder	N/A
Ink cartridge	N/A

HS-80 DIP-switch settings

	ON				OFF			
1-1	CR command produces a line feed				CR command does not produce a line feed			
1-2	Cut-sheet feeder mode on				Cut-sheet feeder mode off			
1-3	NLQ character printing				Draft character printing			

Country	U.S.	France	Germany	U.K.	Denmark	Sweden	Italy	Spain
1-4	ON	ON	ON	ON	OFF	OFF	OFF	OFF
1-5	ON	ON	OFF	OFF	ON	ON	OFF	OFF
1-6	ON	OFF	ON	OFF	ON	OFF	ON	OFF

Built-in features

Print method	9-element ink jet
Speed	NLQ 45 cps @ 10 cpi 54 cps @ 12 cpi Draft 200 cps @ 10 cpi 240 cps @ 12 cpi
Print width	8 inches
Paper types	Continuous, Single sheets
Paper paths	Rear, Top
Paper parking	Not available
Buffer size	8KB
Interfaces	Parallel, Serial
Fonts (typefaces)	Roman, Sans Serif
Nonprintable area	22.0 mm at the top of single sheets

Options (with model numbers)

Cut-sheet feeder	#8347 (Single-bin)
Tractor	#8305 (Pull)
Interfaces	#8131, #8132(W), #8133, #8143, #8145, #8148, #8149, #8149, #8161, #8165, #8172, #8172(M)
Ink cartridge	#8765

IX-800 DIP-switch settings

	ON	OFF
1-1	Condensed printing	Noncondensed printing
1-2	Slashed zero (Ø)	Normal zero (0)
1-3	Graphics character table	Italics character table
1-4	IBM mode	ESC/P mode
1-5	NLQ printing	Draft printing

Country	U.S.	France	Germany	U.K.	Denmark	Sweden	Italy	Spain
1-6	ON	ON	ON	ON	OFF	OFF	OFF	OFF
1-7	ON	ON	OFF	OFF	ON	ON	OFF	OFF
1-8	ON	OFF	ON	OFF	ON	OFF	ON	OFF

	ON	OFF
2-1	12-inch page length	11-inch page length
2-2	Cut-sheet feeder mode on	Cut-sheet feeder mode off
2-3	1-inch skip-over-perforation	No skip-over-perforation
2-4	CR command produces a line feed	CR command does not produce a line feed

Interface	Serial (none)	Serial (even)	Serial (odd)	Parallel
2-5	ON	ON	OFF	OFF
2-6	ON	OFF	ON	OFF

Baud	300	1,200	4,800	9,600
2-7	ON	ON	OFF	OFF

Built-in features

Print method	9-pin impact
Speed	Draft 160 cps @ 10 cpi
Print width	8 inches
Paper types	Continuous, Single sheets
Multipart forms	Original plus 2 copies
Paper paths	Rear, Top
Paper parking	Not available
Buffer size	2KB
Interface	Parallel
Nonprintable area	22.0 mm at the top of single sheets

Options (with model numbers)

Cut-sheet feeder	#8331 (Single-bin)
Tractor	#8300 (Pull)
Roll-paper holder	#8310
Interfaces	#8148, #8165, #8172
Ribbons	N/A

JX-80 DIP-switch settings

	ON	OFF
1-1	Condensed printing	Noncondensed printing
1-2	Slashed zero (Ø)	Normal zero (0)
1-3	Paper-end sensor off	Paper-end sensor on
1-4	2-KB buffer	No buffer
1-5	Emphasized printing	Normal printing

Country	U.S.	France	Germany	U.K.	Denmark	Sweden	Italy	Spain
1-6	ON	ON	ON	ON	OFF	OFF	OFF	OFF
1-7	ON	ON	OFF	OFF	ON	ON	OFF	OFF
1-8	ON	OFF	ON	OFF	ON	OFF	ON	OFF

	ON	OFF
2-1	Receive SLCT IN signal	SLCT IN signal ignored
2-2	Bell available	Bell disabled
2-3	1-inch skip-over-perforation	No skip-over-perforation
2-4	CR command produces a line feed	CR command does not produce a line feed

Built-in features

Print method	9-pin impact
Speed	NLQ 16 cps @ 10 cpi Draft 100 cps @ 10 cpi
Print width	8 inches
Paper types	Continuous, Single sheets
Multipart forms	Original plus 1 copy
Paper paths	Rear, Top
Paper parking	Not available
Buffer size	1KB
Interface	Parallel
Nonprintable area	22.0 mm at the top of single sheets

Options (with model numbers)

Cut-sheet feeder	#8338 (Single-bin)
Tractor	#8304 (Pull)
Interfaces	#8148, #8165, #8172
Ribbon	#8750 (Fabric)

LX-80 DIP-switch settings

	ON	OFF
1-1	Condensed printing	Noncondensed printing
1-2	NLQ printing	Draft printing
1-3	Cut-sheet feeder mode on	Cut-sheet feeder mode off
1-4	Paper-end sensor off	Paper-end sensor on
1-5	12-inch page length	11-inch page length

Country	U.S.	France	Germany	U.K.	Denmark	Sweden	Italy	Spain
1-6	ON	ON	ON	ON	OFF	OFF	OFF	OFF
1-7	ON	ON	OFF	OFF	ON	ON	OFF	OFF
1-8	ON	OFF	ON	OFF	ON	OFF	ON	OFF

	ON	OFF
2-1	Slashed zero (Ø)	Normal zero (0)
2-2	Receive SLCT IN signal	SLCT IN signal ignored
2-3	CR command produces a line feed	CR command does not produce a line feed
2-4	Bell disabled	Bell enabled

Built-in features

Print method	9-pin impact
Speed	NLQ 22 cps @ 10 cpi Draft 120 cps @ 10 cpi
Print width	8 inches
Paper types	Continuous, Single sheets
Multipart forms	(original plus 1 copies)
Paper paths	Rear, Top
Paper parking	Not available
Buffer size	N/A
Interface	Parallel
Font (typeface)	Roman
Nonprintable area	22.0 mm at the top of single sheets

Options (with model numbers)

Cut-sheet feeder	#8338 (Single-bin)
Tractor	#8304 (Pull)
Interfaces	#8148, #8165, #8172
Ribbon	#8750 (Fabric)

LX-86 DIP-switch settings

	ON	OFF
1-1	Condensed printing	Noncondensed printing
1-2	Graphics character table	Italic character table
1-3	Cut-sheet feeder mode on	Cut-sheet feeder mode off
1-4	Paper-end sensor off	Paper-end sensor on
1-5	12-inch page length	11-inch page length

Country	U.S.	France	Germany	U.K.	Denmark	Sweden	Italy	Spain
1-6	ON	ON	ON	ON	OFF	OFF	OFF	OFF
1-7	ON	ON	OFF	OFF	ON	ON	OFF	OFF
1-8	ON	OFF	ON	OFF	ON	OFF	ON	OFF

	ON	OFF
2-1	Slashed zero (Ø)	Normal zero (0)
2-2	Receive SLCT IN signal	SLCT IN signal ignored
2-3	CR command produces a line feed	CR command does not produce a line feed
2-4	Bell disabled	Bell enabled

Built-in features

Print method	9-pin impact
Speed	NLQ 40 cps @ 10 cpi 48 cps @ 12 cpi Draft 200 cps @ 10 cpi 240 cps @ 12 cpi
Print width	8 inches
Paper types	Continuous, Single sheets, Envelopes, Labels
Multipart forms	Original plus 2 copies
Paper paths	Rear, Front
Tractor	Push
Paper parking	Available
Buffer size	4KB
Interface	Parallel
Fonts (typefaces)	Roman, Sans Serif

Options (with model numbers)

Ribbon	S015047 (Fabric)
--------	------------------

LX-100 default-setting mode

This printer has no DIP switches; however, the following settings can be made in a special default-setting mode.

Setting	Options
Character table	PC437, PC437 Greek*, PC850, PC851*, PC852*, PC853*, PC855*, PC857*, PC860, PC863, PC864*, PC865, PC866*, PC869*, U.S.S.R. GOST*
Page length (for continuous paper)	11, 12, 8.5, or 70/6 (A4) inches
Skip-over-perforation	On or Off
Tear-off position	On or Above tear-off edge
Top-of-form position	-3, -2, -1, ±0, 1, 2, 3
Shape of zero	Normal zero (0) or Slashed zero (Ø)
Back feed	Enable or Disable
Auto line feed	On or Off
Character pitch	10 or 12 cpi

* Availability varies by country.

Built-in features

Print method	9-pin impact
Speed	NLQ 44 cps @ 10 cpi 53 cps @ 12 cpi Draft 220 cps @ 10 cpi 264 cps @ 12 cpi
Print width	8 inches
Paper types	Continuous, Single sheets, Envelopes, Labels, Roll paper
Multipart forms	Original plus 2 copies
Paper paths	Rear
Tractor	Detachable push and pull
Paper parking	Available
Buffer size	4KB
Interface	Parallel, Serial
Fonts (typefaces)	Roman, Sans Serif, Draft, Draft Condensed
Nonprintable area	5.3 mm at the top of single sheets

Options (with model numbers)

Color Upgrade Kit	C83208*
Cut-sheet feeder	C80637*
Pull tractor	C80030*
Roll-paper holder	#8310
Ribbons	#8750 (Black), S015073 (Color)

*The last digit of the option model number shown above as an asterisk varies by country.

LX-300 default-setting mode

This printer has no DIP switches; however, the following settings can be made in a special default-setting mode.

Setting	Options
Page length	11, 12, 8.5, 70/6 (A4) inches
Character table	Italic, PC437, PC437 Greek*, PC850, PC852*, PC853*, PC855*, PC857*, PC860, PC861, PC863, PC865, PC866*, PC869*, ISO Latin 1T*, ISO 8859-7, Code MJK*, Mazovia*, Bulgaria*, BRASCII, Abicomp
Page length (for continuous paper)	11, 12, 8.5, or 70/6 (A4) inches
Skip-over-perforation	On or Off
Auto tear off	On or Off
Top-of-form position	-3, -2, -1, 0, +1, +2, +3
Shape of zero	Normal zero (0) or slashed zero (Ø)
Auto line feed	On or Off
Character pitch	10 or 12 cpi
Tractor	Single or Double
Interface	Auto (10 sec. wait), Auto (30 sec. wait), Parallel, Serial
Serial I/F bit rate	300, 600, 1200, 2400, 4800, 9600, 19200 bps
Serial I/F parity bit	None, Odd, or Even
Serial I/F data length	7 bit or 8 bit
Serial I/F ETX/ACK	Disable or Enable

* Availability varies by country.

Built-in features

Print method	9-pin impact
Speed	NLQ 25 cps @ 10 cpi 30 cps @ 12 cpi Draft 150 cps @ 10 cpi 180 cps @ 12 cpi
Print width	8 inches
Paper types	Continuous, Single sheets, Roll paper
Multipart forms	Original plus 2 copies
Paper paths	Rear, Top
Paper parking	Not available
Buffer size	3KB
Interface	Parallel
Fonts (typefaces)	Roman, Sans Serif
Nonprintable area	22.0 mm at the top of single sheets

Options (with model numbers)

Cut-sheet feeder	#7341 (Single-bin)
Roll-paper holder	#8310
Interfaces	#8143, #8148, #8165
Ribbon	#8750 (Fabric)

LX-400 DIP-switch settings

	ON				OFF			
1-1	Condensed printing				Noncondensed printing			
1-2	Slashed zero (Ø)				Normal zero (0)			
1-3	Graphics character table				Italics character table			
1-4	Paper-end sensor off				Paper-end sensor on			
1-5	NLQ printing				Draft printing			
Country	U.S.	France	Germany	U.K.	Denmark	Sweden	Italy	Spain
1-6	ON	ON	ON	ON	OFF	OFF	OFF	OFF
1-7	ON	ON	OFF	OFF	ON	ON	OFF	OFF
1-8	ON	OFF	ON	OFF	ON	OFF	ON	OFF
	ON				OFF			
2-1	12-inch page length				11-inch page length			
2-2	Cut-sheet feeder mode on				Cut-sheet feeder mode off			
2-3	1-inch skip-over-perforation				No skip-over-perforation			
2-4	CR command produces a line feed				CR command does not produce a line feed			

Built-in features

Print method	9-pin impact
Speed	NLQ 25 cps @ 10 cpi 30 cps @ 12 cpi Draft 150 cps @ 10 cpi 180 cps @ 12 cpi
Print width	8 inches
Paper types	Continuous, Single sheets, Roll paper
Multipart forms	Original plus 2 copies
Paper paths	Rear, Top
Tractor	Pull
Paper parking	Not available
Buffer size	3KB
Interface	Parallel
Fonts (typefaces)	Roman, Sans Serif

Options (with model numbers)

Roll-paper holder	#8310
Interfaces	#8143, #8148, #8165
Ribbon	#8750 (Fabric)

LX-400 DIP-switch settings

	ON				OFF			
1-1	User-defined characters				ROM characters			
1-2	Slashed zero (Ø)				Normal zero (0)			
1-3	Graphics character tables				Italics character table			
Paper length	11.7 inches		12 inches		8.5 inches		11 inches	
1-4	ON		ON		OFF		OFF	
1-5	ON		OFF		ON		OFF	
Country (1-3 OFF)	U.S.	France	Germany	U.K.	Denmark	Sweden	Italy	Spain
1-6	ON	ON	ON	ON	OFF	OFF	OFF	OFF
1-7	ON	ON	OFF	OFF	ON	ON	OFF	OFF
1-8	ON	OFF	ON	OFF	ON	OFF	ON	OFF
Character table (1-3 ON)	PC437		PC850		PC860		PC863	
1-6	ON		ON		ON		ON	
1-7	ON		ON		OFF		OFF	
1-8	ON		OFF		ON		ON	
	ON				OFF			
2-1	NLQ printing				Draft printing			
2-2	Cut-sheet feeder mode on				Cut-sheet feeder mode off			
2-3	1-inch skip-over-perforation				No skip-over-perforation			
2-4	CR command produces a line feed				CR command does not produce a line feed			

Built-in features

Print method	9-pin impact
Speed	NLQ 25 cps @ 10 cpi 30 cps @ 12 cpi Draft 150 cps @ 10 cpi 180 cps @ 12 cpi
Print width	8 inches
Paper types	Continuous, Single sheets, Roll paper
Multipart forms	Original plus 2 copies
Paper paths	Rear, Top
Tractor	Pull
Paper parking	Not available
Buffer size	3KB
Interface	Parallel
Fonts (typefaces)	Roman, Sans Serif
Nonprintable area	22.0 mm at the top of single sheets

Options (with model numbers)

Cut-sheet feeder	#8349 (Single-bin)
Roll-paper holder	#8310
Interfaces	#8143, #8148, #8165
Ribbon	#8750 (Fabric)

LX-800 DIP-switch settings

	ON				OFF			
1-1	Condensed printing				Noncondensed printing			
1-2	Slashed zero (Ø)				Normal zero (0)			
1-3	Graphics character table				Italics character table			
1-4	Paper-end sensor off				Paper-end sensor on			
1-5	NLQ printing				Draft printing			
Country	U.S.	France	Germany	U.K.	Denmark	Sweden	Italy	Spain
1-6	ON	ON	ON	ON	OFF	OFF	OFF	OFF
1-7	ON	ON	OFF	OFF	ON	ON	OFF	OFF
1-8	ON	OFF	ON	OFF	ON	OFF	ON	OFF
	ON				OFF			
2-1	12-inch page length				11-inch page length			
2-2	Cut-sheet feeder mode on				Cut-sheet feeder mode off			
2-3	1-inch skip-over-perforation				No skip-over-perforation			
2-4	CR command produces a line feed				CR command does not produce a line feed			

Built-in features

Print method	9-pin impact
Speed	NLQ 25 cps @ 10 cpi 30 cps @ 12 cpi Draft 150 cps @ 10 cpi 180 cps @ 12 cpi High-speed draft 200 cps @ 10 cpi
Print width	8 inches
Paper types	Continuous, Single sheets, Envelopes, Labels, Roll paper
Multipart forms	Original plus 2 copies
Paper paths	Rear, Top
Tractor	Push
Paper parking	Available
Buffer size	4KB
Interface	Parallel
Font (typeface)	Roman

Options (with model numbers)

Cut-sheet feeder	C806121 (Single-bin)
Tractor	C800061 (Pull)
Roll-paper holder	#8310
Interfaces	#8143, #8148, #8165
Ribbon	#8750 (Fabric)

LX-810 DIP-switch settings

	ON				OFF			
1-1	12 cpi				10 cpi			
1-2	Slashed zero (Ø)				Normal zero (0)			
1-3	Graphics character table				Italics character table			
1-4	Automatic tear-off				No automatic tear-off			
1-5	Normal draft printing				High-speed draft printing			
Country	U.S.	France	Germany	U.K.	Denmark	Sweden	Italy	Spain
1-6	ON	ON	ON	ON	OFF	OFF	OFF	OFF
1-7	ON	ON	OFF	OFF	ON	ON	OFF	OFF
1-8	ON	OFF	ON	OFF	ON	OFF	ON	OFF
	ON				OFF			
2-1	12-inch page length				11-inch page length			
2-2	Cut-sheet feeder mode on				Cut-sheet feeder mode off			
2-3	1-inch skip-over-perforation				No skip-over-perforation			
2-4	CR command produces a line feed				CR command does not produce a line feed			

Built-in features

Print method	9-pin impact
Speed	NLQ 25 cps @ 10 cpi 30 cps @ 12 cpi Draft 150 cps @ 10 cpi 180 cps @ 12 cpi High-speed draft 200 cps @ 10 cpi
Print width	8 inches
Paper types	Continuous, Single sheets, Envelopes, Labels, Roll paper
Multipart forms	Original plus 2 copies
Paper paths	Rear, Top
Tractor	Push
Paper parking	Available
Buffer size	4KB
Interface	Parallel
Fonts (typefaces)	Roman, Sans Serif

Options (with model numbers)

Cut-sheet feeder	C806121 (Single-bin)
Tractor	C800061 (Pull)
Roll-paper holder	#8310
Interfaces	#8143, #8148, #8165
Ribbon	#8750 (Fabric)

LX-810 DIP-switch settings

	ON				OFF			
1-1	12 cpi				10 cpi			
1-2	Slashed zero (ø)				Normal zero (0)			
Paper length	11.7 inches		12 inches		8.5 inches		11 inches	
1-3	ON		ON		OFF		OFF	
1-4	ON		OFF		ON		OFF	
1-5	Graphics character tables				Italics character table			
Country (1-5 OFF)	U.S.	France	Germany	U.K.	Denmark	Sweden	Italy	Spain
1-6	ON	ON	ON	ON	OFF	OFF	OFF	OFF
1-7	ON	ON	OFF	OFF	ON	ON	OFF	OFF
1-8	ON	OFF	ON	OFF	ON	OFF	ON	OFF
Character table (1-5 ON)	PC437		PC850		PC860		PC863	
1-6	ON		ON		ON		ON	
1-7	ON		ON		OFF		OFF	
1-8	ON		OFF		ON		OFF	
	ON				OFF			
2-1	Automatic tear-off				No automatic tear-off			
2-2	Cut-sheet feeder mode on				Cut-sheet feeder mode off			
2-3	1-inch skip-over-perforation				No skip-over-perforation			
2-4	CR command produces a line feed				CR command does not produce a line feed			

Built-in features

Print method	9-pin impact
Speed	NLQ 25 cps @ 10 cpi 30 cps @ 12 cpi Draft 150 cps @ 10 cpi 180 cps @ 12 cpi High-speed draft 200 cps @ 10 cpi
Print width	8 inches
Paper types	Continuous, Single sheets, Envelopes, Labels, Roll paper
Multipart forms	Original plus 2 copies
Paper paths	Rear, Top
Tractor	Push
Paper parking	Available
Buffer size	4KB
Interface	Parallel
Fonts (typefaces)	Roman, Sans Serif

Options (with model numbers)

Cut-sheet feeder	C806122 (Single-bin)
Tractor	C800062 (Pull)
Roll-paper holder	#8310
Interfaces	#8143, #8148, #8165
Ribbon	#8750 (Fabric)

LX-850 DIP-switch settings

	ON				OFF			
1-1	12 cpi				10 cpi			
1-2	Slashed zero (Ø)				Normal zero (0)			
1-3	Graphics character table				Italics character table			
1-4	Automatic tear-off				No automatic tear-off			
1-5	Normal draft printing				High-speed draft printing			
Country	U.S.	France	Germany	U.K.	Denmark	Sweden	Italy	Spain
1-6	ON	ON	ON	ON	OFF	OFF	OFF	OFF
1-7	ON	ON	OFF	OFF	ON	ON	OFF	OFF
1-8	ON	OFF	ON	OFF	ON	OFF	ON	OFF
	ON				OFF			
2-1	12-inch page length				11-inch page length			
2-2	Cut-sheet feeder mode on				Cut-sheet feeder mode off			
2-3	1-inch skip-over-perforation				No skip-over-perforation			
2-4	CR command produces a line feed				CR command does not produce a line feed			

Built-in features

Print method	9-pin impact
Speed	NLQ 25 cps @ 10 cpi 30 cps @ 12 cpi Draft 150 cps @ 10 cpi 180 cps @ 12 cpi High-speed draft 200 cps @ 10 cpi
Print width	8 inches
Paper types	Continuous, Single sheets, Envelopes, Labels, Roll paper
Multipart forms	Original plus 2 copies
Paper paths	Rear, Top
Tractor	Push
Paper parking	Available
Buffer size	4KB
Interface	Parallel
Fonts (typefaces)	Roman, Sans Serif

Options (with model numbers)

Cut-sheet feeder	C806122 (Single-bin)
Tractor	C800062 (Pull)
Roll-paper holder	#8310
Interfaces	#8143, #8148, #8165
Ribbon	#8750 (Fabric)

LX-850 DIP-switch settings

	ON				OFF			
1-1	12 cpi				10 cpi			
1-2	Slashed zero (ø)				Normal zero (0)			
Paper length	11.7 inches		12 inches		8.5 inches		11 inches	
1-3	ON		ON		OFF		OFF	
1-4	ON		OFF		ON		OFF	
1-5	Graphics character tables				Italics character table			
Country (1-5 OFF)	U.S.	France	Germany	U.K.	Denmark	Sweden	Italy	Spain
1-6	ON	ON	ON	ON	OFF	OFF	OFF	OFF
1-7	ON	ON	OFF	OFF	ON	ON	OFF	OFF
1-8	ON	OFF	ON	OFF	ON	OFF	ON	OFF
Character table (1-5 ON)	PC437		PC850		PC860		PC863	
1-6	ON		ON		ON		ON	
1-7	ON		ON		OFF		OFF	
1-8	ON		OFF		ON		OFF	
	ON				OFF			
2-1	Automatic tear-off				No automatic tear-off			
2-2	Cut-sheet feeder mode on				Cut-sheet feeder mode off			
2-3	1-inch skip-over-perforation				No skip-over-perforation			
2-4	CR command produces a line feed				CR command does not produce a line feed			

Built-in features

Print method	9-pin impact
Speed	NLQ 25 cps @ 10 cpi 30 cps @ 12 cpi Draft 150 cps @ 10 cpi 180 cps @ 12 cpi High-speed draft 200 cps @ 10 cpi
Print width	13.6 inches
Paper types	Continuous, Single sheets, Envelopes, Labels
Multipart forms	Original plus 2 copies
Paper paths	Rear, Top
Tractor	Push
Paper parking	Available
Buffer size	4KB
Interface	Parallel
Font (typeface)	Roman

Options (with model numbers)

Cut-sheet feeder	C806242 (Single-bin)
Tractor	C800142 (Pull)
Interfaces	#8143, #8148, #8165
Ribbon	#8755 (Fabric)

LX-1050 DIP-switch settings

	ON				OFF			
1-1	12 cpi				10 cpi			
1-2	Slashed zero (ø)				Normal zero (0)			
1-3	Graphics character table				Italics character table			
1-4	Automatic tear-off				No automatic tear-off			
1-5	Normal draft printing				High-speed draft printing			
Country	U.S.	France	Germany	U.K.	Denmark	Sweden	Italy	Spain
1-6	ON	ON	ON	ON	OFF	OFF	OFF	OFF
1-7	ON	ON	OFF	OFF	ON	ON	OFF	OFF
1-8	ON	OFF	ON	OFF	ON	OFF	ON	OFF
	ON				OFF			
2-1	12-inch page length				11-inch page length			
2-2	Cut-sheet feeder mode on				Cut-sheet feeder mode off			
2-3	1-inch skip-over-perforation				No skip-over-perforation			
2-4	CR command produces a line feed				CR command does not produce a line feed			

Built-in features

Print method	9-pin impact
Speed	NLQ 25 cps @ 10 cpi 30 cps @ 12 cpi Draft 150 cps @ 10 cpi 180 cps @ 12 cpi High-speed draft 200 cps @ 10 cpi
Print width	13.6 inches
Paper types	Continuous, Single sheets, Envelopes, Labels
Multipart forms	Original plus 2 copies
Paper paths	Rear, Top
Tractor	Push
Paper parking	Available
Buffer size	4KB
Interface	Parallel
Font (typeface)	Roman, Sans Serif

Options (with model numbers)

Cut-sheet feeder	C806242 (Single-bin)
Tractor	C800142 (Pull)
Interfaces	#8143, #8148, #8165
Ribbon	#8755 (Fabric)

LX-1050 DIP-switch settings

	ON				OFF			
1-1	12 cpi				10 cpi			
1-2	Slashed zero (Ø)				Normal zero (0)			
Paper length	11.7 inches	12 inches	8.5 inches	11 inches				
1-3	ON	ON	OFF	OFF				
1-4	ON	OFF	ON	OFF				
1-5	Graphics character table				Italics character table			
Country (1-5 OFF)	U.S.	France	Germany	U.K.	Denmark	Sweden	Italy	Spain
1-6	ON	ON	ON	ON	OFF	OFF	OFF	OFF
1-7	ON	ON	OFF	OFF	ON	ON	OFF	OFF
1-8	ON	OFF	ON	OFF	ON	OFF	ON	OFF
Character table (1-5 ON)	PC437	PC850	PC860	PC863	PC865			
1-6	ON	ON	ON	ON	OFF			
1-7	ON	ON	OFF	OFF	ON			
1-8	ON	OFF	ON	OFF	ON			
	ON				OFF			
2-1	Automatic tear-off				No automatic tear-off			
2-2	Cut-sheet feeder mode on				Cut-sheet feeder mode off			
2-3	1-inch skip-over-perforation				No skip-over-perforation			
2-4	CR command produces a line feed				CR command does not produce a line feed			

Built-in features

Print method	9-pin impact
Speed	NLQ 40 cps @ 10 cpi 48 cps @ 12 cpi
	Draft 200 cps @ 10 cpi 240 cps @ 12 cpi
Print width	13.6 inches
Paper types	Continuous, Single sheets, Envelopes, Labels
Multipart forms	Original plus 2 copies
Paper paths	Rear, Top
Tractor	Push
Paper parking	Available
Buffer size	4KB
Interface	Parallel
Font (typeface)	Roman, Sans Serif

Options (with model numbers)

Cut-sheet feeder	C80624* (Single-bin)
Tractor	C80014* (Pull)
Interfaces	#8143, #8148, #8165
Ribbon	#8755 (Fabric)

*The last digit of the option model numbers shown above as an asterisk varies by country.

LX-1050+ DIP-switch settings

	ON				OFF			
1-1	12 cpi				10 cpi			
1-2	Slashed zero (ø)				Normal zero (0)			
Page length	11.7 inches	12 inches	8.5 inches	11 inches				
1-3	ON	ON	OFF	OFF				
1-4	ON	OFF	ON	OFF				
	ON				OFF			
1-5	Graphics character table				Italics character table			
Country (1-5 OFF)	U.S.	France	Germany	U.K.	Denmark I	Sweden	Italy	Spain I
1-6	ON	ON	ON	ON	OFF	OFF	OFF	OFF
1-7	ON	ON	OFF	OFF	ON	ON	OFF	OFF
1-8	ON	OFF	ON	OFF	ON	OFF	ON	OFF
Character table (1-5 ON)	PC437	PC850*	PC860*	PC863*	PC865*			
1-6	ON	ON	ON	ON	ON	OFF		
1-7	ON	ON	OFF	OFF	OFF	ON	ON	
1-8	ON	OFF	ON	ON	OFF	OFF	ON	

*These character tables are available only on the European version.

	ON		OFF	
2-1	Automatic tear-off		No automatic tear-off	
2-2	Cut-sheet feeder mode on		Cut-sheet feeder mode off	
2-3	1-inch skip-over-perforation		No skip-over-perforation	
2-4 †	Auto line feed		No auto line feed	

† This setting is available only in IBM mode.

Built-in features

Print method	9-pin impact
Speed	Draft 80 cps @ 10 cpi
Print width	8 inches
Paper type	Continuous
Multipart forms	Original plus 2 copies
Paper path	Rear
Tractor	Pull
Paper parking	Available
Buffer size	N/A
Interface	Parallel

Options (with model numbers)

Ribbon #8750 (Fabric)

MX-80 DIP-switch settings

	ON	OFF
1-1	Not used	Not used
1-2	CR command produces a line feed	CR command does not produce a line feed
1-3	Full buffer produces a CR command	Full buffer produces a line feed
1-4	CAN command not available	CAN command available
1-5	DEL command not available	DEL command available
1-6	Bell enabled	Bell disabled
1-7	Katakana character table	Graphics character table
1-8	Receive SLCT IN signal	SLCT IN signal ignored

Country	U.S.	France	Germany	U.K.
2-1	ON	ON	OFF	OFF
2-2	ON	OFF	ON	OFF

	ON	OFF
2-3 †	Automatic line feed	No automatic line feed
2-4	Code table A	Code table B

† This setting is available only in IBM mode.

Built-in features

Print method	9-pin impact
Speed	Draft 80 cps @ 10 cpi
Print width	8 inches
Paper types	Continuous, Single sheets
Multipart forms	Original plus 2 copies
Paper paths	Rear, Top
Tractor	Pull
Paper parking	Not available
Buffer size	One line
Interface	Parallel
Nonprintable area	22.0 mm at the top of single sheets

Options (with model numbers)

Ribbon #8750 (Fabric)

MX-80 F/T DIP-switch settings

	ON	OFF
1-1	Not used	Not used
1-2	CR command produces a line feed	CR command does not produce a line feed
1-3	Full buffer produces a CR command	Full buffer produces a line feed
1-4	CAN command not available	CAN command available
1-5	DEL command not available	DEL command available
1-6	Bell enabled	Bell disabled
1-7	Katakana character table	Graphics character table
1-8	Receive SLCT IN signal	SLCT IN signal ignored

Country	U.S.	France	Germany	U.K.
2-1	ON	ON	OFF	OFF
2-2	ON	OFF	ON	OFF

	ON	OFF
2-3 †	Automatic line feed	No automatic line feed
2-4	Code table A	Code table B

† This setting is available only in IBM mode.

MX-80 Type II

Year introduced: 1981
Market: Europe, Pacific

Built-in features

Print method	9-pin impact
Speed	Draft 80 cps @ 10 cpi
Print width	8 inches
Paper types	Continuous, Roll paper
Multipart forms	Original plus 2 copies
Paper path	Rear
Tractor	Pull
Paper parking	Not available
Buffer size	One line
Interface	Parallel

Options (with model numbers)

Roll-paper holder	N/A
Ribbon	#8750 (Fabric)

MX-80 Type II DIP-switch settings

	ON		OFF					
1-1	1/8-inch line spacing		1/6-inch line spacing					
1-2	12-inch page length		11-inch page length					
Print type	Emphasized	Not used	Condensed	Normal				
1-3	ON	ON	OFF	OFF				
1-4	ON	OFF	ON	OFF				
	ON		OFF					
1-5	Not used		Not used					
1-6	Paper-end sensor on		Paper-end sensor off					
1-8	Receive SLCT IN signal		SLCT IN signal ignored					
Country	U.S.	France	Germany	U.K.	Denmark	Sweden	Italy	Spain
1-7	ON	ON	ON	ON	OFF	OFF	OFF	OFF
2-1	ON	ON	OFF	OFF	ON	ON	OFF	OFF
2-2	ON	OFF	ON	OFF	ON	OFF	ON	OFF
	ON		OFF					
2-3	CR command produces line feed		CR command does not produce a line feed					
2-4	1-inch skip-over-perforation		No skip-over-perforation					

MX-80 F/T Type II

Year introduced: 1981
Market: Europe, Pacific

Built-in features

Print method	9-pin impact
Speed	Draft 80 cps @ 10 cpi
Print width	8 inches
Paper types	Continuous, Single sheets, Roll paper
Multipart forms	Original plus 2 copies
Paper path	Rear, Top
Tractor	Pull
Paper parking	Not available
Buffer size	One line
Interface	Parallel
Nonprintable area	22.0 mm at the top of single sheets

Options (with model numbers)

Roll-paper holder	N/A
Ribbon	#8750 (Fabric)

MX-80 F/T FType II DIP-switch settings

	ON		OFF					
1-1	1/8-inch line spacing		1/6-inch line spacing					
1-2	12-inch page length		11-inch page length					
Print type	Emphasized	Not used	Condensed	Normal				
1-3	ON	ON	OFF	OFF				
1-4	ON	OFF	ON	OFF				
	ON		OFF					
1-5	Not used		Not used					
1-6	Paper-end sensor on		Paper-end sensor off					
1-8	Receive SLCT IN signal		SLCT IN signal ignored					
Country	U.S.	France	Germany	U.K.	Denmark	Sweden	Italy	Spain
1-7	ON	ON	ON	ON	OFF	OFF	OFF	OFF
2-1	ON	ON	OFF	OFF	ON	ON	OFF	OFF
2-2	ON	OFF	ON	OFF	ON	OFF	ON	OFF
	ON		OFF					
2-3	CR command produces line feed		CR command does not produce a line feed					
2-4	1-inch skip-over-perforation		No skip-over-perforation					

MX-80 Type III

Year introduced: 1982
Market: America, Europe, Pacific

Built-in features

Print method	9-pin impact
Speed	Draft 80 cps @ 10 cpi
Print width	8 inches
Paper types	Continuous, Roll paper
Multipart forms	Original plus 2 copies
Paper path	Rear
Tractor	Pull
Paper parking	Not available
Buffer size	One line
Interface	Parallel

Options (with model numbers)

Roll-paper holder	N/A
Interface	#8143
Ribbon	#8750 (Fabric)

MX-80 Type III DIP-switch settings

	ON		OFF					
1-1	1/8-inch line spacing		1/6-inch line spacing					
1-2	12-inch page length		11-inch page length					
Print type	Emphasized	Not used	Condensed	Normal				
1-3	ON	ON	OFF	OFF				
1-4	ON	OFF	ON	OFF				
	ON		OFF					
1-5	Not used		Not used					
1-6	Paper-end sensor on		Paper-end sensor off					
1-8	Receive SLCT IN signal		SLCT IN signal ignored					
Country	U.S.	France	Germany	U.K.	Denmark	Sweden	Italy	Spain
1-7	ON	ON	ON	ON	OFF	OFF	OFF	OFF
2-1	ON	ON	OFF	OFF	ON	ON	OFF	OFF
2-2	ON	OFF	ON	OFF	ON	OFF	ON	OFF
	ON		OFF					
2-3	CR command produces line feed		CR command does not produce a line feed					
2-4	1-inch skip-over-perforation		No skip-over-perforation					

MX-80 F/T Type III

Year introduced: 1982
Market: America, Europe, Pacific

Built-in features

Print method	9-pin impact
Speed	Draft 80 cps @ 10 cpi
Print width	8 inches
Paper types	Continuous, Single sheets, Roll paper
Multipart forms	Original plus 2 copies
Paper paths	Rear, Top
Tractor	Pull
Paper parking	Not available
Buffer size	One line
Interface	Parallel
Nonprintable area	22.0 mm at the top of single sheets

Options (with model numbers)

Roll-paper holder	N/A
Interface	#8143
Ribbon	#8750 (Fabric)

MX-80 F/T Type III DIP-switch settings

	ON		OFF					
1-1	1/8-inch line spacing		1/6-inch line spacing					
1-2	12-inch page length		11-inch page length					
Print type	Emphasized	Not used	Condensed	Normal				
1-3	ON	ON	OFF	OFF				
1-4	ON	OFF	ON	OFF				
	ON		OFF					
1-5	Not used		Not used					
1-6	Paper-end sensor on		Paper-end sensor off					
1-8	Receive SLCT IN signal		SLCT IN signal ignored					
Country	U.S.	France	Germany	U.K.	Denmark	Sweden	Italy	Spain
1-7	ON	ON	ON	ON	OFF	OFF	OFF	OFF
2-1	ON	ON	OFF	OFF	ON	ON	OFF	OFF
2-2	ON	OFF	ON	OFF	ON	OFF	ON	OFF
	ON		OFF					
2-3	CR command produces line feed		CR command does not produce a line feed					
2-4	1-inch skip-over-perforation		No skip-over-perforation					

Built-in features

Print method	9-pin impact
Speed	Draft 80 cps @ 10 cpi
Print width	8 inches
Paper types	Continuous, Single sheets, Roll paper
Multipart forms	Original plus 2 copies
Paper paths	Rear, Top
Tractor	Pull
Paper parking	Not available
Buffer size	One line
Interface	Parallel

Options (with model numbers)

Roll-paper holder	N/A
Ribbon	#8750 (Fabric)

MX-82 DIP-switch setting

	ON		OFF					
1-1	1/8-inch line spacing		1/6-inch line spacing					
1-2	12-inch page length		11-inch page length					
Print type	Emphasized	Not used	Condensed	Normal				
1-3	ON	ON	OFF	OFF				
1-4	ON	OFF	ON	OFF				
	ON		OFF					
1-5	Not used		Not used					
1-6	Paper-end sensor on		Paper-end sensor off					
1-8	Receive SLCT IN signal		SLCT IN signal ignored					
Country	U.S.	France	Germany	U.K.	Denmark	Sweden	Italy	Spain
1-7	ON	ON	ON	ON	OFF	OFF	OFF	OFF
2-1	ON	ON	OFF	OFF	ON	ON	OFF	OFF
2-2	ON	OFF	ON	OFF	ON	OFF	ON	OFF
	ON		OFF					
2-3	CR command produces line feed		CR command does not produce a line feed					
2-4	1-inch skip-over-perforation		No skip-over-perforation					

MX-82 F/T Type III

Year introduced: 1982
Market: Europe, Pacific

Built-in features

Print method	9-pin impact
Speed	Draft 80 cps @ 10 cpi
Print width	8 inches
Paper types	Continuous, Single sheets, Roll paper
Multipart forms	Original plus 2 copies
Paper paths	Rear, Top
Tractor	Pull
Paper parking	Not available
Buffer size	One line
Interface	Parallel
Nonprintable area	22.0 mm at the top of single sheets

Options (with model numbers)

Roll-paper holder	N/A
Ribbon	#8750 (Fabric)

MX-82 F/T Type III DIP-switch settings

	ON		OFF					
1-1	1/8-inch line spacing		1/6-inch line spacing					
1-2	12-inch page length		11-inch page length					
Print type	Emphasized	Not used	Condensed	Normal				
1-3	ON	ON	OFF	OFF				
1-4	ON	OFF	ON	OFF				
	ON		OFF					
1-5	Not used		Not used					
1-6	Paper-end sensor on		Paper-end sensor off					
1-8	Receive SLCT IN signal		SLCT IN signal ignored					
Country	U.S.	France	Germany	U.K.	Denmark	Sweden	Italy	Spain
1-7	ON	ON	ON	ON	OFF	OFF	OFF	OFF
2-1	ON	ON	OFF	OFF	ON	ON	OFF	OFF
2-2	ON	OFF	ON	OFF	ON	OFF	ON	OFF
	ON		OFF					
2-3	CR command produces line feed		CR command does not produce a line feed					
2-4	1-inch skip-over-perforation		No skip-over-perforation					

Built-in features

Print method	9-pin impact
Speed	Draft 80 cps @ 10 cpi
Print width	13.6 inches
Paper type	Continuous
Multipart forms	Original plus 2 copies
Paper path	Rear
Tractor	Pull
Paper parking	Not available
Buffer size	One line

Options (with model numbers)

Ribbon #8755 (Fabric)

MX-100 DIP-switch settings

	ON		OFF					
1-1	1/8-inch line spacing		1/6-inch line spacing					
1-2	12-inch page length		11-inch page length					
Print type	Emphasized	Not used	Condensed	Normal				
1-3	ON	ON	OFF	OFF				
1-4	ON	OFF	ON	OFF				
	ON		OFF					
1-5	Not used		Not used					
1-6	Paper-end sensor on		Paper-end sensor off					
1-8	Receive SLCT IN signal		SLCT IN signal ignored					
Country	U.S.	France	Germany	U.K.	Denmark	Sweden	Italy	Spain
1-7	ON	ON	ON	ON	OFF	OFF	OFF	OFF
2-1	ON	ON	OFF	OFF	ON	ON	OFF	OFF
2-2	ON	OFF	ON	OFF	ON	OFF	ON	OFF
	ON		OFF					
2-3	CR command produces line feed		CR command does not produce a line feed					
2-4	1-inch skip-over-perforation		No skip-over-perforation					

MX-100 Type III

Year introduced: 1982
Market: America, Europe, Pacific

Built-in features

Print method	9-pin impact
Speed	Draft 80 cps @ 10 cpi
Print width	13.6 inches
Paper type	Continuous
Multipart forms	Original plus 2 copies
Paper path	Rear
Tractor	Pull
Paper parking	Not available
Buffer size	One line
Interface	Parallel

Options (with model numbers)

Interface	#8143
Ribbon	#8755 (Fabric)

MX-100 Type III DIP-switch settings

	ON		OFF					
1-1	1/8-inch line spacing		1/6-inch line spacing					
1-2	12-inch page length		11-inch page length					
Print type	Emphasized	Not used	Condensed	Normal				
1-3	ON	ON	OFF	OFF				
1-4	ON	OFF	ON	OFF				
	ON		OFF					
1-5	Not used		Not used					
1-6	Paper-end sensor on		Paper-end sensor off					
1-8	Receive SLCT IN signal		SLCT IN signal ignored					
Country	U.S.	France	Germany	U.K.	Denmark	Sweden	Italy	Spain
1-7	ON	ON	ON	ON	OFF	OFF	OFF	OFF
2-1	ON	ON	OFF	OFF	ON	ON	OFF	OFF
2-2	ON	OFF	ON	OFF	ON	OFF	ON	OFF
	ON		OFF					
2-3	CR command produces line feed		CR command does not produce a line feed					
2-4	1-inch skip-over-perforation		No skip-over-perforation					

Built-in features

Print method	9-element thermal
Speed	Draft 80 cps @ 10 cpi
Print width	8 inches
Paper types	Single sheets, Roll paper (thermal)
Paper paths	Rear, Top
Paper parking	Available
Buffer size	240 bytes
Interface	Serial (6-pin DIN connector)
Font (typeface)	Roman
Nonprintable area	22.0 mm at the top of single sheets

Options (with model numbers)

Roll-paper holder	N/A
Ribbons	#8760 (Film, thermal)

P-80 DIP-switch settings

Country	U.S.	France	Germany	U.K.	Denmark	Sweden	Italy	Spain								
1-1	ON	ON	ON	ON	OFF	OFF	OFF	OFF								
1-2	ON	ON	OFF	OFF	ON	ON	OFF	OFF								
1-3	ON	OFF	ON	OFF	ON	OFF	ON	OFF								
ON					OFF											
1-4	CR command produces a line feed				CR command does not produce a line feed											
2-1	7-bit data length				8-bit data length											
2-2	Parity checked				No parity check											
2-3	Even parity				Odd parity											
2-4	1 stop bit				2 stop bits											
bps	75	1,800	200	300	134.5	4,800	600	2,400	110	2,400	300	1,200	150	9,600	1,200	9,600
2-5	ON	ON	ON	ON	ON	ON	ON	ON	OFF	OFF	OFF	OFF	OFF	OFF	OFF	OFF
2-6	ON	ON	ON	ON	OFF	OFF	OFF	OFF	ON	ON	ON	ON	OFF	OFF	OFF	OFF
2-7	ON	ON	OFF	OFF	ON	ON	OFF	OFF	ON	ON	OFF	OFF	ON	ON	OFF	OFF
2-8	ON	OFF	ON	OFF	ON	OFF	ON	OFF	ON	OFF	ON	OFF	ON	OFF	ON	OFF

Built-in features

Print method	9-pin impact
Speed	Draft 100 cps @ 10 cpi
Print width	8 inches
Paper type	Continuous
Multipart forms	Original plus 2 copies
Paper path	Rear
Tractor	Pull
Paper parking	Not available
Buffer size	One line
Interface	Parallel

Options (with model numbers)

Roll-paper holder	N/A
Interface	#8143
Ribbon	#8750 (Fabric)

RX-80 DIP-switch settings

	ON	OFF
1-1	Condensed printing	Noncondensed printing
1-2	Print codes 128 to 159 as characters	Use codes 128 to 159 as control codes
1-3	Bell disabled	Bell enabled
1-4	12-inch page length	11-inch page length
1-5	Paper-end sensor off	Paper-end sensor on

Country	U.S.	France	Germany	U.K.	Denmark	Sweden	Italy	Spain
1-6	ON	ON	ON	ON	OFF	OFF	OFF	OFF
1-7	ON	ON	OFF	OFF	ON	ON	OFF	OFF
1-8	ON	OFF	ON	OFF	ON	OFF	ON	OFF

	ON	OFF
2-1	Slashed zero (Ø)	Normal zero (0)
2-2	Receive $\overline{\text{SLCT IN}}$ signal	$\overline{\text{SLCT IN}}$ signal ignored
2-3	CR command produces line feed	CR command does not produce a line feed
2-4	1-inch skip-over-perforation	No skip-over-perforation

Built-in features

Print method	9-pin impact
Speed	Draft 100 cps @ 10 cpi
Print width	8 inches
Paper types	Continuous, Single sheets
Multipart forms	Original plus 2 copies
Paper paths	Rear, Top
Tractor	Pull
Paper parking	Not available
Buffer size	One line
Nonprintable area	22.0 mm at the top of single sheets

Options (with model numbers)

Interface	#8143
Ribbon	#8750 (Fabric)

RX-80 F/T DIP-switch settings

	ON				OFF			
1-1	Condensed printing				Noncondensed printing			
1-2	Print codes 128 to 159 as characters				Use codes 128 to 159 as control codes			
1-3	Bell disabled				Bell enabled			
1-4	12-inch page length				11-inch page length			
1-5	Paper-end sensor off				Paper-end sensor on			
Country	U.S.	France	Germany	U.K.	Denmark	Sweden	Italy	Spain
1-6	ON	ON	ON	ON	OFF	OFF	OFF	OFF
1-7	ON	ON	OFF	OFF	ON	ON	OFF	OFF
1-8	ON	OFF	ON	OFF	ON	OFF	ON	OFF
	ON				OFF			
2-1	Slashed zero (Ø)				Normal zero (0)			
2-2	Receive SLCT IN signal				SLCT IN signal ignored			
2-3	CR command produces line feed				CR command does not produce a line feed			
2-4	1-inch skip-over-perforation				No skip-over-perforation			

Built-in features

Print method	9-pin impact
Speed	Draft 100 cps @ 10 cpi
Print width	8 inches
Paper types	Continuous, Single sheets
Multipart forms	Original plus 2 copies
Paper paths	Rear, Top
Tractor	Pull
Paper parking	Not available
Buffer size	One line
Interface	Parallel
Nonprintable area	22.0 mm at the top of single sheets

Options (with model numbers)

Cut-sheet-feeder	#8330 (Single-bin)
Interfaces	#8120, #8131, #8132, #8143, #8145, #8146, #8148, #8149, #8161, #8165, #8171, #8172, #8177, #8647
Ribbon	#8750 (Fabric)

RX-80 F/T+ DIP-switch settings

	ON				OFF			
1-1	Condensed printing				Noncondensed printing			
1-2	Print codes 128 to 159 as characters				Use codes 128 to 159 as control codes			
1-3	Bell disabled				Bell enabled			
1-4	12-inch page length				11-inch page length			
1-5	Paper-end sensor off				Paper-end sensor on			
Country	U.S.	France	Germany	U.K.	Denmark	Sweden	Italy	Spain
1-6	ON	ON	ON	ON	OFF	OFF	OFF	OFF
1-7	ON	ON	OFF	OFF	ON	ON	OFF	OFF
1-8	ON	OFF	ON	OFF	ON	OFF	ON	OFF
	ON				OFF			
2-1	Slashed zero (Ø)				Normal zero (0)			
2-2	Receive SLCT IN signal				SLCT IN signal ignored			
2-3	CR command produces line feed				CR command does not produce a line feed			
2-4	1-inch skip-over-perforation				No skip-over-perforation			

Built-in features

Print method	9-pin impact
Speed	Draft 100 cps @ 10 cpi
Print width	13.6 inches
Paper type	Continuous
Multipart forms	Original plus 2 copies
Paper path	Rear
Tractor	Pull
Paper parking	Not available
Buffer size	One line
Interface	Parallel

Options (with model numbers)

Interface	#8143
Ribbon	#8755 (Fabric)

RX-100 DIP-switch settings

	ON				OFF			
1-1	Condensed printing				Noncondensed printing			
1-2	Print codes 128 to 159 as characters				Use codes 128 to 159 as control codes			
1-3	Bell disabled				Bell enabled			
1-4	12-inch page length				11-inch page length			
1-5	Paper-end sensor off				Paper-end sensor on			
Country	U.S.	France	Germany	U.K.	Denmark	Sweden	Italy	Spain
1-6	ON	ON	ON	ON	OFF	OFF	OFF	OFF
1-7	ON	ON	OFF	OFF	ON	ON	OFF	OFF
1-8	ON	OFF	ON	OFF	ON	OFF	ON	OFF
	ON				OFF			
2-1	Slashed zero (Ø)				Normal zero (0)			
2-2	Receive SLCT IN signal				SLCT IN signal ignored			
2-3	CR command produces line feed				CR command does not produce a line feed			
2-4	1-inch skip-over-perforation				No skip-over-perforation			

RX-100+

Year introduced: 1984
Market: America, Europe, Pacific

Built-in features

Print method	9-pin impact
Speed	Draft 100 cps @ 10 cpi
Print width	13.6 inches
Paper type	Continuous
Multipart forms	Original plus 2 copies
Paper path	Rear
Tractor	Pull
Paper parking	Not available
Buffer size	One line

Options (with model numbers)

Interfaces	#8120, #8131, #8132, #8143, #8145, #8146, #8148, #8149, #8461, #8165, #8171, #8172, #8177, #8647
Ribbon	#8755 (Fabric)

RX-100+ DIP-switch settings

	ON	OFF
1-1	Condensed printing	Noncondensed printing
1-2	Print codes 128 to 159 as characters	Use codes 128 to 159 as control codes
1-3	Bell disabled	Bell enabled
1-4	12-inch page length	11-inch page length
1-5	Paper-end sensor off	Paper-end sensor on

Country	U.S.	France	Germany	U.K.	Denmark	Sweden	Italy	Spain
1-6	ON	ON	ON	ON	OFF	OFF	OFF	OFF
1-7	ON	ON	OFF	OFF	ON	ON	OFF	OFF
1-8	ON	OFF	ON	OFF	ON	OFF	ON	OFF

	ON	OFF
2-1	Slashed zero (Ø)	Normal zero (0)
2-2	Receive SLCT IN signal	SLCT IN signal ignored
2-3	CR command produces line feed	CR command does not produce a line feed
2-4	1-inch skip-over-perforation	No skip-over-perforation

Appendix

Character Tables	A-2
Proportional Width Information.....	A-21
Proportional width during multipoint mode (ESC/P 2 only)	A-21
24/48-pin proportional width tables.....	A-21
9-pin proportional width tables	A-26
ASCII Code Table	A-30
Parallel Interface.....	A-31
Internal Serial Interface	A-35
Six-pin DIN connector type.....	A-35
25-pin subminiature D-shell connector (female) type.....	A-36
Optional Serial Interfaces.....	A-37
Selecting PreESC/P 2 Fonts in ESC/P 2 Multipoint Mode.....	A-38

Character Tables

Italic

	0	10	20	30	40	50	60	70	80	90	A0	B0	C0	D0	E0	F0
0			0	@	P	'	p				0	@	P	'	p	
1		!	1	A	Q	a	q			!	1	A	Q	a	q	
2		"	2	B	R	b	r			"	2	B	R	b	r	
3		#	3	C	S	c	s			#	3	C	S	c	s	
4		\$	4	D	T	d	t			\$	4	D	T	d	t	
5		%	5	E	U	e	u			%	5	E	U	e	u	
6		&	6	F	V	f	v			&	6	F	V	f	v	
7		'	7	G	W	g	w			'	7	G	W	g	w	
8		(8	H	X	h	x			(8	H	X	h	x	
9)	9	I	Y	i	y)	9	I	Y	i	y	
A		*	:	J	Z	j	z			*	:	J	Z	j	z	
B		+	;	K	[k	{			+	;	K	[k	{	
C		,	<	L	\	l	'			,	<	L	\	l	'	
D		-	=	M]	m	}			-	=	M]	m	}	
E		.	>	N	^	n	~			.	>	N	^	n	~	
F		/	?	O	-	o	_			/	?	O	-	o	_	

PC437 (US)

	0	10	20	30	40	50	60	70	80	90	A0	B0	C0	D0	E0	F0
0			0	@	P	'	p	Ç	É	á			Ł	ł	α	≡
1	☉	◀	!	A	Q	a	q	ü	æ	í			⊥	⊞	β	±
2	⊕	↓	"	B	R	b	r	é	Æ	ó			⊞	⊞	Γ	≥
3	♥	!!	#	C	S	c	s	â	ô	ú			⊞	⊞	π	≤
4	♦	¶	\$	D	T	d	t	ä	ö	ñ			⊞	⊞	Σ	∫
5	♣	§	%	E	U	e	u	à	ò	Ñ			⊞	⊞	σ	∫
6	♠	-	&	F	V	f	v	å	û	ä			⊞	⊞	μ	÷
7	•	↓	'	G	W	g	w	ç	ù	ø			⊞	⊞	τ	≈
8	☐	↑	(H	X	h	x	ê	ÿ	ç			⊞	⊞	Φ	°
9	◦	↓)	I	Y	i	y	ë	Ö	ř			⊞	⊞	Θ	•
A	☐	→	*	:	J	Z	j	z	è	Ü			⊞	⊞	Ω	•
B	♂	←	+	;	K	[k	{	ï	φ	½		⊞	⊞	δ	√
C	♀	⊥	,	<	L	\	l	'	î	£	¼		⊞	⊞	∞	∞
D	♫	↔	-	=	M]	m	}	ì	¥	ı		⊞	⊞	φ	²
E	♫	▲	.	>	N	^	n	~	Ä	Pt	<<		⊞	⊞	ε	■
F	♣	▼	/	?	O	-	o	Δ	Å	f	>>		⊞	⊞	∩	■

PC437 Greek

	0	10	20	30	40	50	60	70	80	90	A0	B0	C0	D0	E0	F0
0	☐	▶	☐	0	@	P	´	p	Α	Ρ	Λ	⊞	⊞	ω	Ω	
1	☐	◀	!	1	A	Q	a	q	Β	Σ	κ	⊞	⊞	ά	±	
2	☐	↕	"	2	B	R	b	r	Γ	Τ	λ	⊞	⊞	έ	≥	
3	☐	!!	#	3	C	S	c	s	Δ	Υ	μ	⊞	⊞	ή	≤	
4	☐	¶	\$	4	D	T	d	t	Ε	Φ	ν	⊞	⊞	ί	∫	
5	☐	§	%	5	E	U	e	u	Z	Χ	ξ	⊞	⊞	ϊ	J	
6	☐	-	&	6	F	V	f	v	H	Ψ	ο	⊞	⊞	ό	÷	
7	☐	↕	'	7	G	W	g	w	Θ	Ω	π	⊞	⊞	ύ	≈	
8	☐	↑	(8	H	X	h	x	Ι	α	ρ	⊞	⊞	ü	°	
9	☐	↓)	9	I	Y	i	y	Κ	β	σ	⊞	⊞	ώ	£	
A	☐	→	*	:	J	Z	j	z	Λ	Υ	ς	⊞	⊞	Ά	¥	
B	☐	←	+	;	K	[k	{	M	δ	τ	⊞	⊞	Έ	√	
C	☐	↳	<	<	L	\	l	!	N	ε	υ	⊞	⊞	Η	ⁿ	
D	☐	↔	-	=	M]	m	}	Ξ	ζ	φ	⊞	⊞	Ί	²	
E	☐	▲	.	>	N	^	n	~	O	η	χ	⊞	⊞	Ό	■	
F	☐	▼	/	?	O	-	o	Δ	Π	θ	ψ	⊞	⊞	Υ		

PC850 (Multilingual)

	0	10	20	30	40	50	60	70	80	90	A0	B0	C0	D0	E0	F0
0	☐	▶	☐	0	@	P	´	p	Ç	É	á	⊞	⊞	ø	Ó	-
1	☐	◀	!	1	A	Q	a	q	ü	æ	í	⊞	⊞	Ð	β	±
2	☐	↕	"	2	B	R	b	r	é	Æ	ó	⊞	⊞	È	Ô	=
3	☐	!!	#	3	C	S	c	s	â	ô	ú	⊞	⊞	Ë	Ò	¾
4	☐	¶	\$	4	D	T	d	t	ä	ö	ñ	⊞	⊞	È	õ	¶
5	☐	§	%	5	E	U	e	u	à	ò	Ñ	Á	⊞	⊞	Ï	§
6	☐	-	&	6	F	V	f	v	â	û	a	À	⊞	⊞	Í	÷
7	☐	↕	'	7	G	W	g	w	ç	ù	Q	À	⊞	⊞	Î	þ
8	☐	↑	(8	H	X	h	x	ê	ÿ	¿	⊞	⊞	Ï	Þ	°
9	☐	↓)	9	I	Y	i	y	ë	ÿ	®	⊞	⊞	Ï	Û	¨
A	☐	→	*	:	J	Z	j	z	è	Ü	¬	⊞	⊞	Û	·	
B	☐	←	+	;	K	[k	{	ï	ø	½	⊞	⊞	Û	¹	
C	☐	↳	<	<	L	\	l	!	î	£	¼	⊞	⊞	Û	³	
D	☐	↔	-	=	M]	m	}	ì	Ø	ï	⊞	⊞	Û	²	
E	☐	▲	.	>	N	^	n	~	Ä	×	«	⊞	⊞	Û	■	
F	☐	▼	/	?	O	-	o	Δ	Å	f	»	⊞	⊞	Û	'	

PC851 (Greek)

	0	10	20	30	40	50	60	70	80	90	A0	B0	C0	D0	E0	F0
0	▶		0	@	P	'	p	Ç	É	ı	◻	◻	◻	◻	α	≡
1	☺	◀	!	1	A	Q	a	q	ü	È	'	◻	◻	◻	β	±
2	☹	↕	"	2	B	R	b	r	é	Ê	ó	◻	◻	◻	Γ	≥
3	♥	!!	#	3	C	S	c	s	â	ô	ú		◻	◻	π	≤
4	♦	¶	\$	4	D	T	d	t	Â	Ë	◻	◻	◻	◻	Σ	∫
5	♣	§	%	5	E	U	e	u	à	ï	◻	◻	◻	◻	σ	∫
6	♠	-	&	6	F	V	f	v	Ŧ	Û	◻	◻	◻	◻	μ	÷
7	•	↕	'	7	G	W	g	w	ç	ù	◻	◻	◻	◻	τ	≈
8	◻	↑	(8	H	X	h	x	ê	α	î	◻	◻	◻	φ	°
9	◦	↓)	9	I	Y	i	y	ë	Ô	◻	◻	◻	◻	θ	•
A	◻	→	*	:	J	Z	j	z	è	Ü	◻	◻	◻	◻	Ω	•
B	♂	←	+	;	K	[k	{	ï	ϕ	½	◻	◻	◻	δ	√
C	♀	◻	,	<	L	\	l		î	£	¼	◻	◻	◻	∞	n
D	♪	↔	-	=	M]	m	}	ì	Ù	¾	◻	◻	◻	φ	²
E	♫	▲	.	>	N	^	n	~	À	Û	◻	◻	◻	◻	ε	◻
F	⊙	▼	/	?	O	-	o	Δ	§	f	»	◻	◻	◻	η	◻

PC853 (Turkish)

	0	10	20	30	40	50	60	70	80	90	A0	B0	C0	D0	E0	F0
0	▶		0	@	P	'	p	Ç	É	á	◻	◻	◻	◻	Ó	-
1	☺	◀	!	1	A	Q	a	q	ü	ç	í	◻	◻	◻	β	◻
2	☹	↕	"	2	B	R	b	r	é	Ç	ó	◻	◻	◻	Ê	ø
3	♥	!!	#	3	C	S	c	s	â	ô	ú		◻	◻	Ë	ò
4	♦	¶	\$	4	D	T	d	t	Ä	ö	ñ	◻	◻	◻	Ë	Ğ
5	♣	§	%	5	E	U	e	u	à	ò	Ñ	Á	◻	◻	ı	ğ
6	♠	-	&	6	F	V	f	v	ê	û	Ğ	Â	Ş	◻	ı	μ
7	•	↕	'	7	G	W	g	w	ç	ù	ğ	À	Ş	◻	ı	Η
8	◻	↑	(8	H	X	h	x	ê	ı	Ĥ	Ş	◻	◻	ı	h
9	◦	↓)	9	I	Y	i	y	ë	Ö	ĥ	◻	◻	◻	ı	◻
A	◻	→	*	:	J	Z	j	z	è	Ü	◻	◻	◻	◻	ı	◻
B	♂	←	+	;	K	[k	{	ï	ğ	½	◻	◻	◻	ı	◻
C	♀	◻	,	<	L	\	l		î	£	¼	◻	◻	◻	ı	◻
D	♪	↔	-	=	M]	m	}	ì	Ğ	Ş	Ž	◻	◻	ı	◻
E	♫	▲	.	>	N	^	n	~	À	×	◻	◻	◻	◻	ı	◻
F	⊙	▼	/	?	O	-	o	Δ	Ç	ĵ	»	◻	◻	◻	ı	◻

PC855 (Cyrillic)

	0	10	20	30	40	50	60	70	80	90	A0	B0	C0	D0	E0	F0
0	▢	▶		0	@	P	'	p	ђ	љ	a	▒	┌	л	Я	-
1	☉	◀	!	1	A	Q	a	q	ћ	љ	А	▒	└	Л	Р	Ы
2	☉	↕	"	2	B	R	b	r	ѓ	њ	Б	▒	┌	М	Р	Ы
3	♥	!!	#	3	C	S	c	s	ђ	њ	Б		└	М	С	З
4	♦	▮	\$	4	D	T	d	t	ё	ћ	Ц	└	└	Н	С	З
5	♣	§	%	5	E	U	e	u	Ё	ћ	Ц	+	└	Н	Т	Ш
6	♠	-	&	6	F	V	f	v	е	ќ	Д	×	К	О	Т	Ш
7	•	↕	'	7	G	W	g	w	Є	Ќ	Д	И	К	О	У	Э
8	▢	↑	(8	H	X	h	x	ѕ	џ	Е	И	┌	п	У	Э
9	◦	↓)	9	I	Y	i	y	Ѕ	џ	Е	┌	┌	Ј	Ж	Щ
A	▢	→	*	:	J	Z	j	z	і	џ	Ф	┌	┌	Ж	Щ	
B	♂	←	+	;	K	[k	{	І	Ц	Ф	┌	┌	В	Ч	
C	♀	└	,	<	L	\	l	;	Ї	Ю	Г	┌	┌	В	Ч	
D	♫	↔	-	=	M]	m	}	Ї	Ю	Г	Й	=	П	Ь	
E	♫	▲	.	>	N	^	n	~	ј	љ	џ	┌	┌	Я	Ь	
F	☼	▼	/	?	O	-	o	△	Ј	љ	>	┌	┌	№		

PC860 (Portugal)

	0	10	20	30	40	50	60	70	80	90	A0	B0	C0	D0	E0	F0
0	▢	▶		0	@	P	'	p	Ç	É	á	▒	┌	┌	α	≡
1	☉	◀	!	1	A	Q	a	q	ü	À	í	▒	└	└	β	±
2	☉	↕	"	2	B	R	b	r	é	È	ó	▒	┌	┌	Γ	≥
3	♥	!!	#	3	C	S	c	s	â	ô	ú		└	┌	π	≤
4	♦	▮	\$	4	D	T	d	t	ã	õ	ñ	└	└	┌	Σ	┌
5	♣	§	%	5	E	U	e	u	à	ò	Ñ	└	└	┌	σ	┌
6	♠	-	&	6	F	V	f	v	Á	Ú	a	└	└	┌	μ	÷
7	•	↕	'	7	G	W	g	w	ç	ù	Q	┌	┌	┌	τ	≈
8	▢	↑	(8	H	X	h	x	ê	ì	ı	┌	┌	┌	φ	°
9	◦	↓)	9	I	Y	i	y	Ê	Ë	Ï	┌	┌	┌	θ	·
A	▢	→	*	:	J	Z	j	z	è	Ü	ı	┌	┌	┌	Ω	·
B	♂	←	+	;	K	[k	{	í	ϕ	½	┌	┌	┌	δ	√
C	♀	└	,	<	L	\	l	;	Ó	£	¼	┌	┌	┌	∞	n
D	♫	↔	-	=	M]	m	}	ì	Û	ı	┌	┌	┌	φ	²
E	♫	▲	.	>	N	^	n	~	Ã	Pt	<<	┌	┌	┌	ε	■
F	☼	▼	/	?	O	-	o	△	À	Ó	>>	┌	┌	┌	∩	

PC863 (Canada-French)

	0	10	20	30	40	50	60	70	80	90	A0	B0	C0	D0	E0	F0
0	◀	▶		0	@	P	'	p	Ç	É	ı	⌘	⌘	⌘	α	≡
1	☺	◀	!	1	A	Q	a	q	ü	È	'	⌘	⌘	⌘	β	±
2	☹	↕	"	2	B	R	b	r	é	Ê	ó	⌘	⌘	⌘	Γ	≥
3	♥	!!	#	3	C	S	c	s	â	ô	ú			⌘	π	≤
4	♦	¶	\$	4	D	T	d	t	Â	Ë	¨	⌘	⌘	⌘	Σ	∫
5	♣	§	%	5	E	U	e	u	à	ï	›	⌘	⌘	⌘	σ	∫
6	♠	-	&	6	F	V	f	v	¶	û	³	⌘	⌘	⌘	μ	÷
7	·	↕	'	7	G	W	g	w	ç	ù	-	⌘	⌘	⌘	τ	≈
8	■	↑	(8	H	X	h	x	ê	ÿ	ˆ	⌘	⌘	⌘	Φ	°
9	◦	↓)	9	I	Y	i	y	ë	Û	˚	⌘	⌘	⌘	Θ	·
A	◻	→	*	:	J	Z	j	z	è	Ü	↵	⌘	⌘	⌘	Ω	·
B	♂	←	+	;	K	[k	{	ï	ϕ	½	⌘	⌘	⌘	δ	√
C	♀	⌘	,	<	L	\	l	'	î	£	¼	⌘	⌘	⌘	∞	n
D	♪	↔	-	=	M]	m	}	ù	¾	⌘	⌘	⌘	⌘	∅	²
E	♫	▲	.	>	N	^	n	~	À	Û	<	⌘	⌘	⌘	ε	■
F	☼	▼	/	?	O	-	o	Δ	§	f	>	⌘	⌘	⌘	∩	

PC865 (Norway)

	0	10	20	30	40	50	60	70	80	90	A0	B0	C0	D0	E0	F0
0	◀	▶		0	@	P	'	p	Ç	É	á	⌘	⌘	⌘	α	≡
1	☺	◀	!	1	A	Q	a	q	ü	æ	í	⌘	⌘	⌘	β	±
2	☹	↕	"	2	B	R	b	r	é	Æ	ó	⌘	⌘	⌘	Γ	≥
3	♥	!!	#	3	C	S	c	s	â	ô	ú			⌘	π	≤
4	♦	¶	\$	4	D	T	d	t	ä	ö	ñ	⌘	⌘	⌘	Σ	∫
5	♣	§	%	5	E	U	e	u	à	ò	ñ	⌘	⌘	⌘	σ	∫
6	♠	-	&	6	F	V	f	v	å	û	ª	⌘	⌘	⌘	μ	÷
7	·	↕	'	7	G	W	g	w	ç	ù	º	⌘	⌘	⌘	τ	≈
8	■	↑	(8	H	X	h	x	ê	ÿ	ˆ	⌘	⌘	⌘	Φ	°
9	◦	↓)	9	I	Y	i	y	ë	Û	˚	⌘	⌘	⌘	Θ	·
A	◻	→	*	:	J	Z	j	z	è	Ü	↵	⌘	⌘	⌘	Ω	·
B	♂	←	+	;	K	[k	{	ï	∅	½	⌘	⌘	⌘	δ	√
C	♀	⌘	,	<	L	\	l	'	î	£	¼	⌘	⌘	⌘	∞	n
D	♪	↔	-	=	M]	m	}	ù	∅	¾	⌘	⌘	⌘	∅	²
E	♫	▲	.	>	N	^	n	~	Ä	Pt	<	⌘	⌘	⌘	ε	■
F	☼	▼	/	?	O	-	o	Δ	Å	f	>	⌘	⌘	⌘	∩	

PC852 (East Europe)

	0	10	20	30	40	50	60	70	80	90	A0	B0	C0	D0	E0	F0
0	▯	▶	▯	0	@	P	'	p	Ç	É	á	▯	Ł	đ	Ó	-
1	☺	◀	!	1	A	Q	a	q	ü	Í	í	▯	ł	Đ	β	˘
2	⊕	↕	"	2	B	R	b	r	é	Í	ó	▯	ł	Đ	Ō	˘
3	♥	!!	#	3	C	S	c	s	â	ô	ú	▯	ł	Ě	Ń	˘
4	♦	¶	\$	4	D	T	d	t	ä	ö	Å	▯	ł	đ	ń	˘
5	♣	§	%	5	E	U	e	u	û	Ĺ	ą	Ą	ł	Ń	ň	§
6	♠	-	&	6	F	V	f	v	ć	ż	Ź	Ą	ł	İ	š	÷
7	•	↕	'	7	G	W	g	w	ç	Ś	ż	Ě	ł	ă	î	ş
8	▯	↑	(8	H	X	h	x	ł	ś	Ź	ł	ł	ě	ř	°
9	◦	↓)	9	I	Y	i	y	ë	Ö	ę	ł	ł	ĵ	Ú	˘
A	▯	→	*	:	J	Z	j	z	ő	Ü	▯	ł	ł	ł	ř	▯
B	♂	←	+	;	K	[k	{	ó	ř	ż	ł	ł	ł	Ú	ú
C	♀	↳	,	<	L	\	l		î	ı	č	ł	ł	ł	ý	ř
D	♪	↔	-	=	M]	m	}	ž	ł	š	ł	ł	ł	Ý	ř
E	♫	▲	.	>	N	^	n	~	Ä	×	«	ł	ł	ł	ł	▯
F	☼	▼	/	?	O	-	o	Δ	Č	č	>	ł	ł	ł	ł	▯

PC857 (Turkish)

	0	10	20	30	40	50	60	70	80	90	A0	B0	C0	D0	E0	F0
0	▯	▶	▯	0	@	P	'	p	Ç	É	á	▯	Ł	q	Ó	-
1	☺	◀	!	1	A	Q	a	q	ü	æ	í	▯	ł	a	β	±
2	⊕	↕	"	2	B	R	b	r	é	Æ	ó	▯	ł	Ě	Ō	˘
3	♥	!!	#	3	C	S	c	s	â	ô	ú	▯	ł	Ě	Ō	¼
4	♦	¶	\$	4	D	T	d	t	ä	ö	ñ	ł	ł	Ě	õ	¶
5	♣	§	%	5	E	U	e	u	à	ò	Ñ	Ą	ł	ł	Ō	§
6	♠	-	&	6	F	V	f	v	â	û	Ğ	Ą	ł	ı	μ	÷
7	•	↕	'	7	G	W	g	w	ç	ù	ğ	Ą	ł	ĭ	ı	▯
8	▯	↑	(8	H	X	h	x	ê	î	▯	ł	ł	ı	×	°
9	◦	↓)	9	I	Y	i	y	è	Ö	▯	ł	ł	ł	Ú	˘
A	▯	→	*	:	J	Z	j	z	è	Ü	▯	ł	ł	ł	Ú	˘
B	♂	←	+	;	K	[k	{	ï	ø	½	ł	ł	ł	Ú	¹
C	♀	↳	,	<	L	\	l		î	£	¼	ł	ł	ł	ı	³
D	♪	↔	-	=	M]	m	}	ı	Ø	ı	ł	ł	ł	ı	²
E	♫	▲	.	>	N	^	n	~	Ä	Ş	«	ł	ł	ł	ı	▯
F	☼	▼	/	?	O	-	o	Δ	Ä	ş	>	ł	ł	ł	ı	▯

PC864 (Arabic)

	0	10	20	30	40	50	60	70	80	90	A0	B0	C0	D0	E0	F0
0		▶		0	@	P	'	p	°	Б		•	Ф	ذ	—	ت
1	⊕	◀	!	1	A	Q	a	q	•	∞	-	ا	ع	ر	ف	س
2	♪	↑	"	2	B	R	b	r	•	∅	ل	ز	آ	ز	ق	ن
3	♯	!!	#	3	C	S	c	s	√	±	£	ز	ا	س	ك	°
4	*	¶	\$	4	D	T	d	t	∴	½	¤	ع	و	ش	ل	+
5	=	§	x	5	E	U	e	u	-	¼	ل	°	ص	ح	م	س
6		-	&	6	F	V	f	v		∞		ا	ض	ث	ن	ف
7	‡	‡	'	7	G	W	g	w	†	«		ا	ط	ه	خ	ت
8	‡	↑	(8	H	X	h	x	‡	»	ل	ا	ظ	و	ق	ي
9	‡	↓)	9	I	Y	i	y	‡	»	ل	ا	ع	ع	ي	ا
A	‡	→	*	:	J	Z	j	z	‡	»	ل	ا	غ	ت	ب	ا
B	‡	←	+	;	K	[k	{	‡	»	ل	ا	ث	ا	ض	ل
C	‡	↳	,	<	L	\	l		:	‡	»	ل	ا	ح	ك	ك
D	‡	↔	-	=	M]	m	}	‡	»	ل	ا	ش	ح	ي	غ
E	‡	▲	.	>	N	^	n	~	‡	»	ل	ا	ص	خ	غ	■
F	‡	▼	/	?	O	_	o	Δ	‡	»	ل	ا	ع	د	ع	م

PC866 (Russian)

	0	10	20	30	40	50	60	70	80	90	A0	B0	C0	D0	E0	F0
0		▶		0	@	P	'	p	А	Р	а	•	Л	л	р	Ё
1	⊕	◀	!	1	A	Q	a	q	Б	С	б	•	Л	л	с	Ё
2	⊕	↑	"	2	B	R	b	r	В	Т	в	•	Л	л	т	Е
3	♥	!!	#	3	C	S	c	s	Г	У	г	•	Л	л	у	Е
4	♦	¶	\$	4	D	T	d	t	Д	Ф	д	•	Л	л	ф	İ
5	♣	§	%	5	E	U	e	u	Е	Х	е	•	Л	л	х	İ
6	♠	-	&	6	F	V	f	v	Ж	Ц	ж	•	Л	л	ц	ÿ
7	•	↑	'	7	G	W	g	w	З	Ч	з	•	Л	л	ч	ÿ
8	■	↑	(8	H	X	h	x	И	Ш	и	•	Л	л	ш	°
9	°	↓)	9	I	Y	i	y	Й	Щ	й	•	Л	л	щ	•
A	⊕	→	*	:	J	Z	j	z	К	Ъ	к	•	Л	л	ъ	•
B	♂	←	+	;	K	[k	{	Л	Ы	л	•	Л	л	ы	√
C	♀	↳	,	<	L	\	l		М	Ь	м	•	Л	л	ь	No
D	♪	↔	-	=	M]	m	}	Н	Э	н	•	Л	л	э	α
E	♯	▲	.	>	N	^	n	~	О	Ю	о	•	Л	л	ю	■
F	⊕	▼	/	?	O	_	o	Δ	П	Я	п	•	Л	л	я	■

PC866 LAT. (Latvian)

	0	10	20	30	40	50	60	70	80	90	A0	B0	C0	D0	E0	F0	
0	◀	▶		0	@	P	'	p	A	P	a	◻	◻	◻	Š	ŗ	Ē
1	☉	◀	!	1	A	Q	a	q	Б	С	б	◻	◻	◻	с	ē	241
2	☉	↕	"	2	B	R	b	r	В	Т	в	◻	◻	◻	č	т	Ģ
3	♥	!!	#	3	C	S	c	s	Г	У	г	◻	◻	◻	č	у	ķ
4	♦	¶	\$	4	D	T	d	t	Д	Ф	д	◻	◻	◻	ф	ķ	244
5	♣	§	%	5	E	U	e	u	Е	Х	e	Ā	†	◻	х	ļ	245
6	♠	-	&	6	F	V	f	v	Ж	Ц	ж	ā	ġ	◻	ц	ļ	246
7	•	↕	'	7	G	W	g	w	З	Ч	з	ņ	†	◻	ч	ž	247
8	▣	↑	(8	H	X	h	x	И	Ш	и	◻	◻	◻	ш	ž	248
9	◦	↓)	9	I	Y	i	y	Й	Щ	й	†	◻	◻	щ	ō	249
A	◻	→	*	:	J	Z	j	z	К	Ъ	к	◻	◻	◻	ъ	•	250
B	♂	←	+	;	K	[k	{	Л	Ы	л	†	◻	◻	ы	√	251
C	♀	└	,	<	L	\	l	'	М	Ь	м	◻	◻	◻	ь	Ņ	252
D	♪	↔	-	=	M]	m	}	Н	Э	н	◻	◻	◻	э	š	253
E	♫	▲	.	>	N	^	n	~	О	Ю	о	◻	◻	◻	ū	ю	254
F	☼	▼	/	?	O	-	o	Δ	П	Я	п	◻	◻	◻	я		255

PC869 (Greek)

	0	10	20	30	40	50	60	70	80	90	A0	B0	C0	D0	E0	F0	
0	◀	▶		0	@	P	'	p	ι	ϊ	◻	◻	◻	◻	τ	ζ	-
1	☉	◀	!	1	A	Q	a	q	ι	ϊ	◻	◻	◻	◻	Υ	η	±
2	☉	↕	"	2	B	R	b	r	ο	ό	◻	◻	◻	◻	φ	θ	υ
3	♥	!!	#	3	C	S	c	s	υ	◻	◻	◻	◻	◻	χ	ι	φ
4	♦	¶	\$	4	D	T	d	t	Α	Υ	α	†	◻	◻	ψ	κ	χ
5	♣	§	%	5	E	U	e	u	Υ	Β	Κ	†	◻	◻	Ω	λ	§
6	♠	-	&	6	F	V	f	v	Ά	ÿ	Γ	Λ	Π	α	μ	ψ	
7	•	↕	'	7	G	W	g	w	©	Δ	Μ	Ρ	θ	ν	~		
8	▣	↑	(8	H	X	h	x	Ω	Ε	Ν	◻	◻	◻	Υ	Ξ	ο
9	◦	↓)	9	I	Y	i	y	²	Ζ	◻	◻	◻	◻	ο	~	249
A	◻	→	*	:	J	Z	j	z	³	Η	◻	◻	◻	◻	π	ω	250
B	♂	←	+	;	K	[k	{	´	ά	½	†	◻	◻	ρ	ύ	251
C	♀	└	,	<	L	\	l	'	£	Θ	◻	◻	◻	◻	σ	ű	252
D	♪	↔	-	=	M]	m	}	Ε	Ε	Ι	≡	◻	◻	δ	ς	ώ
E	♫	▲	.	>	N	^	n	~	-	ή	◻	◻	◻	◻	ε	τ	254
F	☼	▼	/	?	O	-	o	Δ	Η	ί	»	◻	◻	◻	Σ	◻	255

USSR GOST (Russian)

	0	10	20	30	40	50	60	70	80	90	A0	B0	C0	D0	E0	F0
0	▢	▶	▢	0	@	P	'	p	┘	┘	А	Р	а	р	Ё	
1	☺	◀	!	1	A	Q	a	q	┘	┘	Б	С	б	с	ё	
2	☹	↕	"	2	B	R	b	r	┘	┘	В	Т	в	т	/	
3	♥	!!	#	3	C	S	c	s	┘	┘	Г	У	г	у	\	
4	♦	¶	\$	4	D	T	d	t	┘	=	-	Д	Ф	д	ф	/
5	♣	§	%	5	E	U	e	u	┘	┘	Е	Х	е	х	\	
6	♠	-	&	6	F	V	f	v	┘	┘	Ж	Ц	ж	ц	→	
7	•	↕	'	7	G	W	g	w	┘	┘	З	Ч	э	ч	←	
8	▣	↑	(8	H	X	h	x	┘	┘	И	Ш	и	ш	↑	
9	◦	↓)	9	I	Y	i	y	┘	┘	Й	Щ	й	щ	↓	
A	◉	→	*	:	J	Z	j	z	┘	┘	К	Ъ	к	ъ	÷	
B	♂	←	+	;	K	[k	{	┘	┘	Л	Ы	л	ы	±	
C	♀	┘	,	<	L	\	l	;	┘	┘	М	Ь	м	ь	№	
D	♪	↔	-	=	M]	m	}	┘	┘	Н	Э	н	э	α	
E	♫	▲	.	>	N	^	n	~	┘	┘	О	Ю	о	ю	■	
F	⊛	▼	/	?	O	-	o	Δ	┘	┘	П	Я	п	я		

KU42 (K.U. Thai)

	0	10	20	30	40	50	60	70	80	90	A0	B0	C0	D0	E0	F0
0	▢	▶	▢	0	@	P	'	p	┘	◌	อ	ย	เ	'	๓	
1	☺	◀	!	1	A	Q	a	q	┘	อ	ก	ณ	ร	แ	'	
2	☹	↕	"	2	B	R	b	r	┘	บ	ข	ด	ฤ	เ	'	
3	♥	!!	#	3	C	S	c	s	┘	ศ	ค	ต	ล	ใ	'	
4	♦	¶	\$	4	D	T	d	t	┘	ด	ช	ถ	ว	ไ	'	
5	♣	§	%	5	E	U	e	u	┘	เ	ง	ท	ศ	า	'	
6	♠	-	&	6	F	V	f	v	┘	ว	จ	บ	ช	า	'	
7	•	↕	'	7	G	W	g	w	┘	ณ	ณ	น	ส	'		
8	▣	↑	(8	H	X	h	x	┘	เ	ช	บ	ห	'		
9	◦	↓)	9	I	Y	i	y	┘	ณ	ช	บ	พ	'		
A	◉	→	*	:	J	Z	j	z	┘	ข	ณ	ณ	อ	'		
B	♂	←	+	;	K	[k	{	┘	ค	ณ	ณ	ย	'		
C	♀	┘	,	<	L	\	l	;	┘	ณ	พ	ะ	'			
D	♪	↔	-	=	M]	m	}	┘	ณ	พ	ภ	'			
E	♫	▲	.	>	N	^	n	~	┘	ณ	ภ	า	'			
F	⊛	▼	/	?	O	-	o	Δ	┘	เ	พ	ณ	'			

TIS11 (TS 988 Thai)

	0	10	20	30	40	50	60	70	80	90	A0	B0	C0	D0	E0	F0
0	◀	▶		0	@	P	'	p	◌	◌	◌	◌	◌	◌	◌	◌
1	☺	◀	!	1	A	Q	a	q	◌	◌	◌	◌	◌	◌	◌	◌
2	☹	↕	"	2	B	R	b	r	◌	◌	◌	◌	◌	◌	◌	◌
3	♥	!!	#	3	C	S	c	s	◌	◌	◌	◌	◌	◌	◌	◌
4	♦	¶	\$	4	D	T	d	t	◌	◌	◌	◌	◌	◌	◌	◌
5	♣	§	%	5	E	U	e	u	◌	◌	◌	◌	◌	◌	◌	◌
6	♠	-	&	6	F	V	f	v	◌	◌	◌	◌	◌	◌	◌	◌
7	•	↕	'	7	G	W	g	w	◌	◌	◌	◌	◌	◌	◌	◌
8	▣	↑	(8	H	X	h	x	◌	◌	◌	◌	◌	◌	◌	◌
9	◦	↓)	9	I	Y	i	y	◌	◌	◌	◌	◌	◌	◌	◌
A	◻	→	*	:	J	Z	j	z	◌	◌	◌	◌	◌	◌	◌	◌
B	♂	←	+	;	K	[k	{	◌	◌	◌	◌	◌	◌	◌	◌
C	♀	↵	,	<	L	\	l		◌	◌	◌	◌	◌	◌	◌	◌
D	♪	↔	-	=	M]	m	}	◌	◌	◌	◌	◌	◌	◌	◌
E	♫	▲	.	>	N	^	n	~	◌	◌	◌	◌	◌	◌	◌	◌
F	☼	▼	/	?	O	_	o	△	◌	◌	◌	◌	◌	◌	◌	◌

TIS18 (GENERAL Thai)

	0	10	20	30	40	50	60	70	80	90	A0	B0	C0	D0	E0	F0
0	◀	▶		0	@	P	'	p	◌	◌	◌	◌	◌	◌	◌	◌
1	☺	◀	!	1	A	Q	a	q	◌	◌	◌	◌	◌	◌	◌	◌
2	☹	↕	"	2	B	R	b	r	◌	◌	◌	◌	◌	◌	◌	◌
3	♥	!!	#	3	C	S	c	s	◌	◌	◌	◌	◌	◌	◌	◌
4	♦	¶	\$	4	D	T	d	t	◌	◌	◌	◌	◌	◌	◌	◌
5	♣	§	%	5	E	U	e	u	◌	◌	◌	◌	◌	◌	◌	◌
6	♠	-	&	6	F	V	f	v	◌	◌	◌	◌	◌	◌	◌	◌
7	•	↕	'	7	G	W	g	w	◌	◌	◌	◌	◌	◌	◌	◌
8	▣	↑	(8	H	X	h	x	◌	◌	◌	◌	◌	◌	◌	◌
9	◦	↓)	9	I	Y	i	y	◌	◌	◌	◌	◌	◌	◌	◌
A	◻	→	*	:	J	Z	j	z	◌	◌	◌	◌	◌	◌	◌	◌
B	♂	←	+	;	K	[k	{	◌	◌	◌	◌	◌	◌	◌	◌
C	♀	↵	,	<	L	\	l		◌	◌	◌	◌	◌	◌	◌	◌
D	♪	↔	-	=	M]	m	}	◌	◌	◌	◌	◌	◌	◌	◌
E	♫	▲	.	>	N	^	n	~	◌	◌	◌	◌	◌	◌	◌	◌
F	☼	▼	/	?	O	_	o	△	◌	◌	◌	◌	◌	◌	◌	◌

TIS17 (SIC STD. Thai)

	0	10	20	30	40	50	60	70	80	90	A0	B0	C0	D0	E0	F0
0	◻	▶	◻	0	@	P	'	p	◻	◻	◻	◻	◻	◻	◻	◻
1	☺	◀	!	1	A	Q	a	q	◻	◻	◻	◻	◻	◻	◻	◻
2	☹	↕	"	2	B	R	b	r	◻	◻	◻	◻	◻	◻	◻	◻
3	♥	!!	#	3	C	S	c	s	◻	◻	◻	◻	◻	◻	◻	◻
4	♦	¶	\$	4	D	T	d	t	◻	◻	◻	◻	◻	◻	◻	◻
5	♣	§	%	5	E	U	e	u	◻	◻	◻	◻	◻	◻	◻	◻
6	♠	-	&	6	F	V	f	v	◻	◻	◻	◻	◻	◻	◻	◻
7	•	↕	'	7	G	W	g	w	+	◻	◻	◻	◻	◻	◻	◻
8	▣	↑	(8	H	X	h	x	◻	◻	◻	◻	◻	◻	◻	◻
9	◊	↓)	9	I	Y	i	y	◻	◻	◻	◻	◻	◻	◻	◻
A	◻	→	*	:	J	Z	j	z	◻	◻	◻	◻	◻	◻	◻	◻
B	♂	←	+	;	K	[k	{	◻	◻	◻	◻	◻	◻	◻	◻
C	♀	⌞	,	<	L	\	l		◻	◻	◻	◻	◻	◻	◻	◻
D	♫	↔	-	=	M]	m	}	◻	◻	◻	◻	◻	◻	◻	◻
E	♫	▲	.	>	N	^	n	~	◻	◻	◻	◻	◻	◻	◻	◻
F	☼	▼	/	?	O	_	o	△	◻	◻	◻	◻	◻	◻	◻	◻

TIS13 (IBM STD. Thai)

	0	10	20	30	40	50	60	70	80	90	A0	B0	C0	D0	E0	F0
0	◻	▶	◻	0	@	P	'	p	◻	◻	◻	◻	◻	◻	◻	◻
1	☺	◀	!	1	A	Q	a	q	◻	◻	◻	◻	◻	◻	◻	◻
2	☹	↕	"	2	B	R	b	r	◻	◻	◻	◻	◻	◻	◻	◻
3	♥	!!	#	3	C	S	c	s	◻	◻	◻	◻	◻	◻	◻	◻
4	♦	¶	\$	4	D	T	d	t	◻	◻	◻	◻	◻	◻	◻	◻
5	♣	§	%	5	E	U	e	u	◻	◻	◻	◻	◻	◻	◻	◻
6	♠	-	&	6	F	V	f	v	◻	◻	◻	◻	◻	◻	◻	◻
7	•	↕	'	7	G	W	g	w	+	◻	◻	◻	◻	◻	◻	◻
8	▣	↑	(8	H	X	h	x	◻	◻	◻	◻	◻	◻	◻	◻
9	◊	↓)	9	I	Y	i	y	◻	◻	◻	◻	◻	◻	◻	◻
A	◻	→	*	:	J	Z	j	z	◻	◻	◻	◻	◻	◻	◻	◻
B	♂	←	+	;	K	[k	{	◻	◻	◻	◻	◻	◻	◻	◻
C	♀	⌞	,	<	L	\	l		◻	◻	◻	◻	◻	◻	◻	◻
D	♫	↔	-	=	M]	m	}	◻	◻	◻	◻	◻	◻	◻	◻
E	♫	▲	.	>	N	^	n	~	◻	◻	◻	◻	◻	◻	◻	◻
F	☼	▼	/	?	O	_	o	△	◻	◻	◻	◻	◻	◻	◻	◻

TIS16 (SIC OLD Thai)

	0	10	20	30	40	50	60	70	80	90	A0	B0	C0	D0	E0	F0
0	◻	▶	◻	0	@	P	'	p	┌	๒	๓	๔	๕	๖	๗	๘
1	☉	◀	!	1	A	Q	a	q	└	๙	๑	๒	๓	๔	๕	๖
2	☊	↕	"	2	B	R	b	r	┌	๑๐	๑๑	๑๒	๑๓	๑๔	๑๕	๑๖
3	♥	!!	#	3	C	S	c	s	└	๑๗	๑๘	๑๙	๒๐	๒๑	๒๒	๒๓
4	♦	¶	\$	4	D	T	d	t	┌	๒๔	๒๕	๒๖	๒๗	๒๘	๒๙	๓๐
5	♣	§	%	5	E	U	e	u	└	๓๑	๓๒	๓๓	๓๔	๓๕	๓๖	๓๗
6	♠	-	&	6	F	V	f	v	┌	๓๘	๓๙	๔๐	๔๑	๔๒	๔๓	๔๔
7	•	↕	'	7	G	W	g	w	└	๔๕	๔๖	๔๗	๔๘	๔๙	๕๐	๕๑
8	▣	↑	(8	H	X	h	x	┌	๕๒	๕๓	๕๔	๕๕	๕๖	๕๗	๕๘
9	◦	↓)	9	I	Y	i	y	└	๕๙	๖๐	๖๑	๖๒	๖๓	๖๔	๖๕
A	◻	→	*	:	J	Z	j	z	┌	๖๖	๖๗	๖๘	๖๙	๗๐	๗๑	๗๒
B	♂	←	+	;	K	[k	{	▣	๗๓	๗๔	๗๕	๗๖	๗๗	๗๘	๗๙
C	♀	└	,	<	L	\	l		◻	๘๐	๘๑	๘๒	๘๓	๘๔	๘๕	๘๖
D	♫	↔	-	=	M]	m	}	↑	๘๗	๘๘	๘๙	๙๐	๙๑	๙๒	๙๓
E	♫	▲	.	>	N	^	n	~	→	๙๔	๙๕	๙๖	๙๗	๙๘	๙๙	๑๐๐
F	☼	▼	/	?	O	_	o	△	↓	๑๐๑	๑๐๒	๑๐๓	๑๐๔	๑๐๕	๑๐๖	๑๐๗

PC861 (Iceland)

	0	10	20	30	40	50	60	70	80	90	A0	B0	C0	D0	E0	F0
0	◻	▶	◻	0	@	P	'	p	Ç	É	á	◻	◻	◻	◻	◻
1	☉	◀	!	1	A	Q	a	q	ü	æ	í	◻	◻	◻	◻	◻
2	☊	↕	"	2	B	R	b	r	é	Æ	ó	◻	◻	◻	◻	◻
3	♥	!!	#	3	C	S	c	s	â	ô	ú	◻	◻	◻	◻	◻
4	♦	¶	\$	4	D	T	d	t	ä	ö	Á	┌	└	◻	◻	◻
5	♣	§	%	5	E	U	e	u	à	þ	í	┌	└	◻	◻	◻
6	♠	-	&	6	F	V	f	v	å	ú	Ó	┌	└	◻	◻	◻
7	•	↕	'	7	G	W	g	w	ç	Ý	Ú	┌	└	◻	◻	◻
8	▣	↑	(8	H	X	h	x	ê	ý	í	┌	└	◻	◻	◻
9	◦	↓)	9	I	Y	i	y	ë	Ö	í	┌	└	◻	◻	◻
A	◻	→	*	:	J	Z	j	z	è	Ü	◻	◻	◻	◻	◻	◻
B	♂	←	+	;	K	[k	{	Ð	ø	½	┌	└	◻	◻	◻
C	♀	└	,	<	L	\	l		ð	£	¼	┌	└	◻	◻	◻
D	♫	↔	-	=	M]	m	}	Þ	ø	í	┌	└	◻	◻	◻
E	♫	▲	.	>	N	^	n	~	Ä	Pt	<	┌	└	◻	◻	◻
F	☼	▼	/	?	O	_	o	△	Å	f	>	┌	└	◻	◻	◻

BRASCI

	0	10	20	30	40	50	60	70	80	90	A0	B0	C0	D0	E0	F0
0			0	@	P	'	p					°	À	Ð	à	ð
1		!	1	A	Q	a	q			i	±	Á	Ñ	á	ñ	
2		"	2	B	R	b	r			²	²	Â	Ò	â	ò	
3		#	3	C	S	c	s			£	³	Ã	Ó	ã	ó	
4		\$	4	D	T	d	t			¤	´	Ä	Ô	ä	ô	
5		%	5	E	U	e	u			¥	µ	Å	Ö	å	ö	
6		&	6	F	V	f	v			¦	¶	Æ	Ø	æ	ø	
7		'	7	G	W	g	w			§	·	Ç	Æ	ç	œ	
8		(8	H	X	h	x			¨	¨	È	Ø	è	ø	
9)	9	I	Y	i	y			©	¹	É	Ù	é	ù	
A		*	:	J	Z	j	z			ª	º	Ê	Ú	ê	ú	
B		+	;	K	[k	{			«	»	Ë	Û	ë	û	
C		,	<	L	\	l				¬	¼	Ì	Ü	ì	ü	
D		-	=	M]	m	}			–	½	Í	Ý	í	ý	
E		.	>	N	^	n	~			®	¾	Î	Þ	î	þ	
F		/	?	O	_	o				—	¿	Ï	ß	ï	ÿ	

Abicomp

	0	10	20	30	40	50	60	70	80	90	A0	B0	C0	D0	E0	F0
0			0	@	P	'	p					°	À	Ð	à	ð
1		!	1	A	Q	a	q				Á	Ó	á	ó		
2		"	2	B	R	b	r				Â	Ô	â	ô		
3		#	3	C	S	c	s				Ã	Õ	ã	õ		
4		\$	4	D	T	d	t				Ä	Ö	ä	ö		
5		%	5	E	U	e	u				Å	Ø	å	ø		
6		&	6	F	V	f	v				Ç	Ù	ç	ù		
7		'	7	G	W	g	w				È	Ú	è	ú		
8		(8	H	X	h	x				É	Û	é	û		
9)	9	I	Y	i	y				Ê	Ü	ê	ü		
A		*	:	J	Z	j	z				Ë	Ý	ë	ÿ		
B		+	;	K	[k	{				Ì	¨	ì	β		
C		,	<	L	\	l					Í	£	í	α		
D		-	=	M]	m	}				Î	·	î	ο		
E		.	>	N	^	n	~				Ï	§	ï	ζ		
F		/	?	O	_	o					Ñ	°	ñ	±		

MAZOWIA (Poland)

	0	10	20	30	40	50	60	70	80	90	A0	B0	C0	D0	E0	F0
0			0	@	P	'	p	Ç	É	Ż	☐	☐	☐	☐	α	≡
1		!	1	A	Q	a	q	ü	ę	ż	☐	☐	☐	☐	β	±
2		"	2	B	R	b	r	é	†	ó	☐	☐	☐	☐	Γ	≥
3		#	3	C	S	c	s	â	ô	Ó	☐	☐	☐	☐	π	≤
4		\$	4	D	T	d	t	ä	ö	ń	☐	☐	☐	☐	Σ	∫
5		%	5	E	U	e	u	à	Ć	Ń	☐	☐	☐	☐	σ	∫
6		&	6	F	V	f	v	ą	û	ź	☐	☐	☐	☐	μ	÷
7		'	7	G	W	g	w	ç	ù	ż	☐	☐	☐	☐	τ	≈
8		(8	H	X	h	x	ê	Ś	ś	☐	☐	☐	☐	Φ	°
9)	9	I	Y	i	y	ë	Ö	ř	☐	☐	☐	☐	Θ	·
A		*	:	J	Z	j	z	è	Ü	ŕ	☐	☐	☐	☐	Ω	·
B		+	;	K	[k	{	ï	żł	½	☐	☐	☐	☐	δ	√
C		,	<	L	\	l	'	î	ł	¼	☐	☐	☐	☐	∞	ⁿ
D		-	=	M]	m	}	ć	¥	ı	☐	☐	☐	☐	φ	²
E		.	>	N	^	n	~	Ä	Ś	«	☐	☐	☐	☐	€	■
F		/	?	O	_	o		À	f	»	☐	☐	☐	☐	∩	

Code MJK (CSFR)

	0	10	20	30	40	50	60	70	80	90	A0	B0	C0	D0	E0	F0
0			0	@	P	'	p	Č	É	á	☐	☐	☐	☐	α	≡
1		!	1	A	Q	a	q	ü	ž	í	☐	☐	☐	☐	β	±
2		"	2	B	R	b	r	é	ž	ó	☐	☐	☐	☐	Γ	≥
3		#	3	C	S	c	s	d'	ô	ú	☐	☐	☐	☐	π	≤
4		\$	4	D	T	d	t	ä	ö	ň	☐	☐	☐	☐	Σ	∫
5		%	5	E	U	e	u	ď	ó	ň	☐	☐	☐	☐	σ	∫
6		&	6	F	V	f	v	ř	û	ů	☐	☐	☐	☐	μ	÷
7		'	7	G	W	g	w	č	ú	ô	☐	☐	☐	☐	τ	≈
8		(8	H	X	h	x	ě	ý	š	☐	☐	☐	☐	Φ	°
9)	9	I	Y	i	y	ě	ö	ř	☐	☐	☐	☐	Θ	·
A		*	:	J	Z	j	z	ĺ	ü	ř	☐	☐	☐	☐	Ω	·
B		+	;	K	[k	{	í	š	ř	☐	☐	☐	☐	δ	√
C		,	<	L	\	l	'	ř	ł	¼	☐	☐	☐	☐	∞	ⁿ
D		-	=	M]	m	}	í	ý	š	☐	☐	☐	☐	φ	²
E		.	>	N	^	n	~	Ä	Ř	«	☐	☐	☐	☐	€	■
F		/	?	O	_	o		Á	ť	»	☐	☐	☐	☐	∩	

ISO 8859-7 (Latin/Greek)

	0	10	20	30	40	50	60	70	80	90	A0	B0	C0	D0	E0	F0
0			0	@	P	´	p				°	ı	Π	Ú	π	
1	!	1	A	Q	a	q		´	±	A	P	α	ρ			
2	"	2	B	R	b	r		²	²	B		β	ς			
3	#	3	C	S	c	s		£	³	Γ	Σ	Υ	σ			
4	\$	4	D	T	d	t				Δ	Τ	δ	τ			
5	%	5	E	U	e	u			´	E	Υ	ε	υ			
6	&	6	F	V	f	v		´	´	Z	Φ	ζ	φ			
7	'	7	G	W	g	w		§	·	H	Χ	η	χ			
8	(8	H	X	h	x		¨	´	Θ	Ψ	θ	ψ			
9)	9	I	Y	i	y		©	´	Η	Ι	Ω	ι	ω		
A	*	:	J	Z	j	z		´	´	K	İ	κ	ı			
B	+	;	K	[k	{		«	»	Λ	ÿ	λ	ü			
C	,	<	L	\	l			¬	´	Ο	Μ	ά	μ	ό		
D	-	=	M]	m	}		½	´	N	É	ν	ύ			
E	.	>	N	^	n	~		´	´	Υ	Ξ	ξ	ώ			
F	/	?	O	-	o	Δ		-	´	Ω	Ο	ί	ο			

TSM/WIN (Thai system manager)

	0	10	20	30	40	50	60	70	80	90	A0	B0	C0	D0	E0	F0
0			0	@	P	´	p	๑	๒		๓	๔	๕	๖	๗	๘
1	!	1	A	Q	a	q	๑	๒	๓	๔	๕	๖	๗	๘	๙	๐
2	"	2	B	R	b	r	๑	๒	๓	๔	๕	๖	๗	๘	๙	๐
3	#	3	C	S	c	s	๑	๒	๓	๔	๕	๖	๗	๘	๙	๐
4	\$	4	D	T	d	t	๑	๒	๓	๔	๕	๖	๗	๘	๙	๐
5	%	5	E	U	e	u	๑	๒	๓	๔	๕	๖	๗	๘	๙	๐
6	&	6	F	V	f	v	๑	๒	๓	๔	๕	๖	๗	๘	๙	๐
7	'	7	G	W	g	w	๑	๒	๓	๔	๕	๖	๗	๘	๙	๐
8	(8	H	X	h	x	๑	๒	๓	๔	๕	๖	๗	๘	๙	๐
9)	9	I	Y	i	y	๑	๒	๓	๔	๕	๖	๗	๘	๙	๐
A	*	:	J	Z	j	z	๑	๒	๓	๔	๕	๖	๗	๘	๙	๐
B	+	;	K	[k	{	๑	๒	๓	๔	๕	๖	๗	๘	๙	๐
C	,	<	L	\	l		๑	๒	๓	๔	๕	๖	๗	๘	๙	๐
D	-	=	M]	m	}	๑	๒	๓	๔	๕	๖	๗	๘	๙	๐
E	.	>	N	^	n	~	๑	๒	๓	๔	๕	๖	๗	๘	๙	๐
F	/	?	O	-	o	Δ	๑	๒	๓	๔	๕	๖	๗	๘	๙	๐

ISO Latin 1T (Turkish)

	0	10	20	30	40	50	60	70	80	90	A0	B0	C0	D0	E0	F0
0			0	@	P	'	p				°	À	Ğ	à	ğ	
1	!	1	A	Q	a	q				i	±	Á	Ñ	á	ñ	
2	"	2	B	R	b	r				²	Â	Ò	â	ò		
3	#	3	C	S	c	s				£	³	Ã	Ó	ã	ó	
4	\$	4	D	T	d	t				¤	´	Ä	Ö	ä	ö	
5	%	5	E	U	e	u				¥	µ	Å	Û	å	ü	
6	&	6	F	V	f	v				¶	¶	Æ	Ö	æ	ö	
7	'	7	G	W	g	w				§	·	Ç	×	ç	÷	
8	(8	H	X	h	x				¨	¨	È	Ø	è	ø	
9)	9	I	Y	i	y				©	¹	É	Ù	é	ù	
A	*	:	J	Z	j	z				ª	º	Ê	Ú	ê	ú	
B	+	;	K	[k	{				<	>	Ë	Û	ë	û	
C	,	<	L	\	l	;				¼	¼	Ì	Ü	ì	ü	
D	-	=	M]	m	}				½	½	Í	İ	í	ı	
E	.	>	N	^	n	~				¾	¾	Î	Ş	î	ş	
F	/	?	O	_	o	~				¿	¿	Ï	ß	ï	ÿ	

Bulgaria

	0	10	20	30	40	50	60	70	80	90	A0	B0	C0	D0	E0	F0
0			0	@	P	'	p	A	P	a	p	ˆ	ˆ	ˆ	ˆ	ˆ
1	!	1	A	Q	a	q	Б	С	б	с	ˆ	ˆ	ˆ	ˆ	ˆ	ˆ
2	"	2	B	R	b	r	В	Т	в	т	ˆ	ˆ	ˆ	ˆ	ˆ	ˆ
3	#	3	C	S	c	s	Г	У	г	у	ˆ	ˆ	ˆ	ˆ	ˆ	ˆ
4	\$	4	D	T	d	t	Д	Ф	д	ф	ˆ	ˆ	ˆ	ˆ	ˆ	ˆ
5	%	5	E	U	e	u	Е	Х	е	х	ˆ	ˆ	ˆ	ˆ	ˆ	ˆ
6	&	6	F	V	f	v	Ж	Ц	ж	ц	ˆ	ˆ	ˆ	ˆ	ˆ	ˆ
7	'	7	G	W	g	w	З	Ч	з	ч	ˆ	ˆ	ˆ	ˆ	ˆ	ˆ
8	(8	H	X	h	x	И	Ш	и	ш	ˆ	ˆ	ˆ	ˆ	ˆ	ˆ
9)	9	I	Y	i	y	Й	Щ	й	щ	ˆ	ˆ	ˆ	ˆ	ˆ	ˆ
A	*	:	J	Z	j	z	К	Ъ	к	ъ	ˆ	ˆ	ˆ	ˆ	ˆ	ˆ
B	+	;	K	[k	{	Л	Ы	л	ы	ˆ	ˆ	ˆ	ˆ	ˆ	ˆ
C	,	<	L	\	l	;	М	Ь	м	ь	ˆ	ˆ	ˆ	ˆ	ˆ	ˆ
D	-	=	M]	m	}	Н	Э	н	э	ˆ	ˆ	ˆ	ˆ	ˆ	ˆ
E	.	>	N	^	n	~	О	Ю	о	ю	ˆ	ˆ	ˆ	ˆ	ˆ	ˆ
F	/	?	O	_	o	~	П	Я	п	я	ˆ	ˆ	ˆ	ˆ	ˆ	ˆ

Roman 8

	0	10	20	30	40	50	60	70	80	90	A0	B0	C0	D0	E0	F0
0	0	!	"	#	\$	%	&	'	()	*	+	,	-	.	/
1	1	A	B	C	D	E	F	G	H	I	J	K	L	M	N	O
2	2	Q	R	S	T	U	V	W	X	Y	Z	[\]	^	_
3	3	a	b	c	d	e	f	g	h	i	j	k	l	m	n	o
4	4	q	r	s	t	u	v	w	x	y	z	{		}	~	€
5	5	À	Á	Â	Ã	Ä	Å	Æ	Ç	È	É	Ê	Ë	Ï	Ì	Í
6	6	Ï	Ï	Ï	Ï	Ï	Ï	Ï	Ï	Ï	Ï	Ï	Ï	Ï	Ï	Ï
7	7	Ï	Ï	Ï	Ï	Ï	Ï	Ï	Ï	Ï	Ï	Ï	Ï	Ï	Ï	Ï
8	8	Ï	Ï	Ï	Ï	Ï	Ï	Ï	Ï	Ï	Ï	Ï	Ï	Ï	Ï	Ï
9	9	Ï	Ï	Ï	Ï	Ï	Ï	Ï	Ï	Ï	Ï	Ï	Ï	Ï	Ï	Ï
A	10	Ï	Ï	Ï	Ï	Ï	Ï	Ï	Ï	Ï	Ï	Ï	Ï	Ï	Ï	Ï
B	11	Ï	Ï	Ï	Ï	Ï	Ï	Ï	Ï	Ï	Ï	Ï	Ï	Ï	Ï	Ï
C	12	Ï	Ï	Ï	Ï	Ï	Ï	Ï	Ï	Ï	Ï	Ï	Ï	Ï	Ï	Ï
D	13	Ï	Ï	Ï	Ï	Ï	Ï	Ï	Ï	Ï	Ï	Ï	Ï	Ï	Ï	Ï
E	14	Ï	Ï	Ï	Ï	Ï	Ï	Ï	Ï	Ï	Ï	Ï	Ï	Ï	Ï	Ï
F	15	Ï	Ï	Ï	Ï	Ï	Ï	Ï	Ï	Ï	Ï	Ï	Ï	Ï	Ï	Ï

PC774 (Lithuania)

	0	10	20	30	40	50	60	70	80	90	A0	B0	C0	D0	E0	F0
0	0	!	"	#	\$	%	&	'	()	*	+	,	-	.	/
1	1	A	B	C	D	E	F	G	H	I	J	K	L	M	N	O
2	2	Q	R	S	T	U	V	W	X	Y	Z	[\]	^	_
3	3	a	b	c	d	e	f	g	h	i	j	k	l	m	n	o
4	4	q	r	s	t	u	v	w	x	y	z	{		}	~	€
5	5	À	Á	Â	Ã	Ä	Å	Æ	Ç	È	É	Ê	Ë	Ï	Ì	Í
6	6	Ï	Ï	Ï	Ï	Ï	Ï	Ï	Ï	Ï	Ï	Ï	Ï	Ï	Ï	Ï
7	7	Ï	Ï	Ï	Ï	Ï	Ï	Ï	Ï	Ï	Ï	Ï	Ï	Ï	Ï	Ï
8	8	Ï	Ï	Ï	Ï	Ï	Ï	Ï	Ï	Ï	Ï	Ï	Ï	Ï	Ï	Ï
9	9	Ï	Ï	Ï	Ï	Ï	Ï	Ï	Ï	Ï	Ï	Ï	Ï	Ï	Ï	Ï
A	10	Ï	Ï	Ï	Ï	Ï	Ï	Ï	Ï	Ï	Ï	Ï	Ï	Ï	Ï	Ï
B	11	Ï	Ï	Ï	Ï	Ï	Ï	Ï	Ï	Ï	Ï	Ï	Ï	Ï	Ï	Ï
C	12	Ï	Ï	Ï	Ï	Ï	Ï	Ï	Ï	Ï	Ï	Ï	Ï	Ï	Ï	Ï
D	13	Ï	Ï	Ï	Ï	Ï	Ï	Ï	Ï	Ï	Ï	Ï	Ï	Ï	Ï	Ï
E	14	Ï	Ï	Ï	Ï	Ï	Ï	Ï	Ï	Ï	Ï	Ï	Ï	Ï	Ï	Ï
F	15	Ï	Ï	Ï	Ï	Ï	Ï	Ï	Ï	Ï	Ï	Ï	Ï	Ï	Ï	Ï

Estonia (Estonia)

	0	10	20	30	40	50	60	70	80	90	A0	B0	C0	D0	E0	F0
0		▶		0	@	P	'	p	Ç	É	á	◻	◻	◻	◻	◻
1	☉	◀	!	1	A	Q	a	q	ü	æ	í	◻	◻	◻	◻	◻
2	⊕	↕	"	2	B	R	b	r	é	Æ	ó	◻	◻	◻	◻	◻
3	♥	!!	#	3	C	S	c	s	â	ô	ú	◻	◻	◻	◻	◻
4	♦	¶	\$	4	D	T	d	t	ä	ö	ñ	◻	◻	◻	◻	◻
5	♣	§	%	5	E	U	e	u	à	ò	Ñ	Á	†	◻	◻	◻
6	♠	-	&	6	F	V	f	v	â	û	ä	Ä	ä	í	μ	÷
7	•	↕	'	7	G	W	g	w	ç	ù	Q	À	Ã	î	ž	³
8	■	↑	(8	H	X	h	x	ê	ÿ	¿	©	◻	◻	◻	◻
9	◦	↓)	9	I	Y	i	y	ë	Ö	®	◻	◻	◻	◻	◻
A	◻	→	*	:	J	Z	j	z	è	Ü	◻	◻	◻	◻	◻	◻
B	♂	←	+	;	K	[k	{	ï	ø	½	◻	◻	◻	◻	◻
C	♀	↖	,	<	L	\	l		î	£	¼	◻	◻	◻	◻	◻
D	♪	↔	-	=	M]	m	}	ì	Ø	⅓	◻	◻	◻	◻	◻
E	♫	▲	.	>	N	^	n	~	Ä	×	¥	◻	◻	◻	◻	◻
F	⊙	▼	/	?	O	-	o	△	Å	f	»	◻	◻	◻	◻	◻

ISO Latin 1

	0	10	20	30	40	50	60	70	80	90	A0	B0	C0	D0	E0	F0
0				0	@	P	'	p			°	À	Ð	à	ð	
1		!	1	A	Q	a	q			i	±	Á	Ñ	á	ñ	
2		"	2	B	R	b	r			¢	²	Â	Ò	â	ò	
3		#	3	C	S	c	s			£	³	Ã	Ó	ã	ó	
4		\$	4	D	T	d	t			¤	´	Ä	Ô	ä	ô	
5		%	5	E	U	e	u			¥	µ	Å	Õ	å	õ	
6		&	6	F	V	f	v			¦	¶	Æ	Ö	æ	ö	
7		'	7	G	W	g	w			§	·	Ç	×	ç	÷	
8		(8	H	X	h	x			¨	ˆ	È	Ø	è	ø	
9)	9	I	Y	i	y			©	˜	É	Ù	é	ù	
A		*	:	J	Z	j	z			ª	º	Ê	Ú	ê	ú	
B		+	;	K	[k	{			«	»	Ë	Û	ë	û	
C		,	<	L	\	l				¬	¼	Ì	Ü	ì	ü	
D		-	=	M]	m	}			½	⅓	Í	Ý	í	ý	
E		.	>	N	^	n	~			®	¾	Î	Þ	î	þ	
F		/	?	O	-	o	△			™	¿	Ï	ß	ï	ÿ	

ISO 8859-2 (ISO Latin 2)

	0	10	20	30	40	50	60	70	80	90	A0	B0	C0	D0	E0	F0
0			0	@	P	'	p				°	Ř	Đ	ř	đ	
1		!	1	A	Q	a	q			À	á	Ā	Ń	ą	ń	
2		"	2	B	R	b	r			˘	˘	˘	˘	˘	˘	
3		#	3	C	S	c	s			Ł	ł	Ā	Ó	ă	ó	
4		\$	4	D	T	d	t			Ǻ	ǻ	Ā	Ö	ä	ö	
5		%	5	E	U	e	u			Ĺ	ĺ	Ĺ	Ó	í	ó	
6		&	6	F	V	f	v			Ś	ś	Ć	Ö	ć	ö	
7		'	7	G	W	g	w			Ş	ş	Ç	×	ç	÷	
8		(8	H	X	h	x			˙	˙	Č	Ř	č	ř	
9)	9	I	Y	i	y			Š	š	É	Û	é	ű	
A		*	:	J	Z	j	z			Ș	ș	Ț	Û	ț	ú	
B		+	;	K	[k	{			Ť	ť	Ě	Ú	ě	ú	
C		<	,	L	\	l				Ž	ž	Ě	Ü	ě	ü	
D		=	=	M]	m	}			-	˘	˘	Í	Ý	í	ý
E		.	>	N	^	n	˘			Ž	ž	Î	İ	î	ı	
F		/	?	O	-	o	˘			Ž	ž	Ď	β	ď	·	

Proportional Width Information

Proportional width during multipoint mode (ESC/P 2 only)

ESC/P 2

The width of proportional characters during multipoint mode varies depending on your selected point size.

The width is calculated based on the width of proportional 10-point (10.5-point) characters, using the following formula:

$$(\text{character width}) = \frac{\text{INT} \left(\frac{(\text{point size}) \times (\text{base width})}{10.5} + 0.5 \right)}{360} \text{ inch}$$

The base width in the above equation is the width listed for each character in the 24/48-pin proportional width tables in the next section.

For example, the width of a 26-point “e” would be determined as follows:

$$(\text{character width}) = \frac{\text{INT} \left(\frac{(26) \times (30)}{10.5} + 0.5 \right)}{360} \text{ inch}$$

$$(\text{character width}) = \frac{\text{INT} (74.786)}{360} \text{ inch}$$

$$(\text{character width}) = \frac{74}{360} \text{ inch}$$

24/48-pin proportional width tables

The tables in this section list the widths for all proportional 10.5-point characters on 24/48-pin printers.

The widths listed are in 1/360-inch units. For example, the width of the letter w during proportional spacing is 42/360 inch.

Upright and italic characters, 24-pin		
Character	Code	Width
SP	32	30
!	33	18
"	34	30
#	35	30
\$	36	30
%	37	36
&	38	36
'	39	18
(40	24

Upright and italic characters, 24-pin		
Character	Code	Width
)	41	24
*	42	30
+	43	30
,	44	18
-	45	30
.	46	18
/	47	30
0	48	30
1	49	30

Upright and italic characters, 24-pin		
Character	Code	Width
2	50	30
3	51	30
4	52	30
5	53	30
6	54	30
7	55	30
8	56	30
9	57	30
:	58	18

Upright and italic characters, 24-pin		
Character	Code	Width
<i>i</i>	59	18
<	60	30
=	61	30
>	62	30
?	63	30
@	64	36
A	65	36
B	66	36
C	67	36
D	68	36
E	69	36
F	70	36
G	71	36
H	72	36
I	73	24
J	74	30
K	75	36
L	76	36
M	77	42
N	78	36
O	79	36
P	80	36
Q	81	36
R	82	36
S	83	36
T	84	36
U	85	42
V	86	36
W	87	42
X	88	36
Y	89	36
Z	90	30
[91	24
\	92	30
]	93	24
^	94	30
_	95	30
`	96	18
a	97	30
b	98	36
c	99	30

Upright and italic characters, 24-pin		
Character	Code	Width
d	100	36
e	101	30
f	102	24
g	103	36
h	104	36
i	105	18
j	106	24
k	107	36
l	108	18
m	109	42
n	110	36
o	111	30
p	112	36
q	113	36
r	114	30
s	115	30
t	116	24
u	117	36
v	118	36
w	119	42
x	120	30
y	121	36
z	122	30
{	123	24
	124	18
}	125	24
~	126	30
none	127	none
Ç	128	36
ü	129	36
é	130	30
â	131	30
ä	132	30
à	133	30
å	134	30
ç	135	30
ê	136	30
ë	137	30
è	138	30
ï	139	18
î	140	18

Upright and italic characters, 24-pin		
Character	Code	Width
î	141	18
Ä	142	36
Å	143	36
É	144	36
æ	145	42
Æ	146	42
ô	147	30
ö	148	30
ò	149	30
û	150	36
ù	151	36
ÿ	152	36
Ö	153	36
Ü	154	42
ç	155	30
£	156	30
¥	157	36
₤	158	42
<i>f</i>	159	30
á	160	30
í	161	18
ó	162	30
ú	163	36
ñ	164	36
Ñ	165	36
ª	166	30
º	167	30
¿	168	30
	169	30
¬	170	30
½	171	30
¼	172	30
ı	173	30
«	174	30
»	175	30
	176	30
	177	30
	178	30
	179	30
	180	30
	181	30

Upright and italic characters, 24-pin		
Character	Code	Width
	182	30
	183	30
	184	30
	185	30
	186	30
	187	30
	188	30
	189	30
	190	30
	191	30
	192	30
	193	30
	194	30
	195	30
	196	30
	197	30
	198	30
	199	30
	200	30
	201	30
	202	30
	203	30
	204	30
	205	30
	206	30
	207	30
	208	30
	209	30
	210	30
	211	30
	212	30
	213	30
	214	30
	215	30
	216	30
	217	30
	218	30
	219	30
	220	30
	221	30
	222	30

Upright and italic characters, 24-pin		
Character	Code	Width
	223	30
	224	30
ß	225	30
	226	30
	227	30
	228	30
	229	30
μ	230	30
	231	30
	232	30
	233	30
	234	30
	235	30
	236	30
	237	30
	238	30
	239	30
	240	30
±	241	30
	242	30
	243	30
	244	30
	245	30
÷	246	30
	247	30
°	248	30
·	249	30
·	250	30
	251	30
	252	30
²	253	30
	254	30
SP	255	30

Upright and italic international characters, 24-pin		
Character	Code	Width
°	none	24
◻	none	30
ß	none	36
¨	none	36
	none	30
Û	none	30
§	none	30
ü	none	36
é	none	30
ä	none	30
à	none	30
å	none	30
ç	none	30
ê	none	30
î	none	18
Ä	none	36
₩	none	42
Å	none	36
É	none	36
æ	none	42
Æ	none	42
ö	none	30
ò	none	30
ù	none	36
Ö	none	36
Û	none	42
£	none	30
¥	none	36
₣	none	42
ñ	none	36
Ñ	none	36
¿	none	30
¡	none	30

Upright and italic superscript/subscript characters, 24-pin		
Character	Code	Width
SP	32	20
!	33	12
"	34	20
#	35	20
\$	36	20
%	37	24
&	38	24
'	39	12
(40	16
)	41	16
*	42	20
+	43	20
,	44	12
-	45	20
.	46	12
/	47	20
0	48	20
1	49	20
2	50	20
3	51	20
4	52	20
5	53	20
6	54	20
7	55	20
8	56	20
9	57	20
:	58	12
;	59	12
<	60	20
=	61	20
>	62	20
?	63	20
@	64	24
A	65	24
B	66	24
C	67	24
D	68	24
E	69	24
F	70	24
G	71	24

Upright and italic superscript/subscript characters, 24-pin		
Character	Code	Width
H	72	24
I	73	16
J	74	20
K	75	24
L	76	24
M	77	28
N	78	24
O	79	24
P	80	24
Q	81	24
R	82	24
S	83	24
T	84	24
U	85	28
V	86	24
W	87	28
X	88	24
Y	89	24
Z	90	20
[91	16
\	92	20
]	93	16
^	94	20
_	95	20
`	96	12
a	97	20
b	98	24
c	99	20
d	100	24
e	101	20
f	102	16
g	103	24
h	104	24
i	105	12
j	106	16
k	107	24
l	108	12
m	109	28
n	110	24
o	111	20

Upright and italic superscript/subscript characters, 24-pin		
Character	Code	Width
p	112	24
q	113	24
r	114	20
s	115	20
t	116	16
u	117	24
v	118	24
w	119	28
x	120	20
y	121	24
z	122	20
{	123	16
	124	12
}	125	16
~	126	20
none	127	none
Ç	128	24
ü	129	24
é	130	20
â	131	20
ä	132	20
à	133	20
å	134	20
ç	135	20
ê	136	20
ë	137	20
è	138	20
ï	139	12
î	140	12
ì	141	12
Ä	142	24
Å	143	24
É	144	24
æ	145	28
Æ	146	28
ô	147	20
ö	148	20
ò	149	20
û	150	24
ù	151	24

Upright and italic superscript/subscript characters, 24-pin		
Character	Code	Width
ÿ	152	24
ö	153	24
ü	154	28
ç	155	20
£	156	20
¥	157	24
₤	158	28
f	159	20
á	160	20
í	161	12
ó	162	20
ú	163	24
ñ	164	24
Ñ	165	24
ª	166	20
º	167	20
¿	168	20
	169	20
¬	170	20
½	171	20
¼	172	20
ı	173	12
«	174	20
»	175	20
	224	20
ß	225	20
	226	20
	227	20
	228	20
	229	20
μ	230	20
	231	20
	232	20
	233	20
	234	20
	235	20
	236	20
	237	20
	238	20
	239	20

Upright and italic superscript/subscript international characters, 24-pin		
Character	Code	Width
°	none	20
α	none	24
β	none	24
”	none	20
	none	20
Û	none	20
§	none	24
ü	none	20
é	none	20
ä	none	20
à	none	20
â	none	20
ç	none	20
ê	none	20
î	none	12
Ä	none	24
₩	none	42
Å	none	24
É	none	24
æ	none	28
Æ	none	28
ö	none	20
ò	none	20
ù	none	24
Ö	none	24
Ü	none	28
£	none	20
¥	none	24
₤	none	28
ñ	none	24
Ñ	none	24
¿	none	20
ı	none	12

Upright and Italic legal characters, 24-pin		
Character	Code	Width
°	none	30
”	none	30
,	none	18
®	none	36
™	none	36
'	none	18
¶	none	30
©	none	36
†	none	30

Upright and italic superscript/subscript legal characters, 24-pin		
Character	Code	Width
°	none	30
”	none	30
,	none	18
®	none	36
™	none	36
'	none	18
¶	none	30
©	none	36
†	none	30

9-pin proportional width tables

The tables in this section list the widths for all proportional characters on 9-pin printers.

The widths listed are in 1/120-inch units. For example, the width of an italic letter w during proportional spacing is 12/120 inch.

Upright characters, 9-pin		
Character	Code	Width
SP	32	12
!	33	5
"	34	8
#	35	12
\$	36	12
%	37	12
&	38	12
'	39	5
(40	6
)	41	6
*	42	12
+	43	12
,	44	7
-	45	12
.	46	6
/	47	10
0	48	12
1	49	8
2	50	12
3	51	12
4	52	12
5	53	12
6	54	12
7	55	12
8	56	12
9	57	12
:	58	6
;	59	6
<	60	10
=	61	12
>	62	10
?	63	12
@	64	12
A	65	12
B	66	12

Upright characters, 9-pin		
Character	Code	Width
C	67	12
D	68	12
E	69	12
F	70	12
G	71	12
H	72	12
I	73	8
J	74	11
K	75	12
L	76	12
M	77	12
N	78	12
O	79	12
P	80	12
Q	81	12
R	82	12
S	83	12
T	84	12
U	85	12
V	86	12
W	87	12
X	88	10
Y	89	12
Z	90	10
[91	8
\	92	10
]	93	8
^	94	12
_	95	12
`	96	5
a	97	12
b	98	11
c	99	11
d	100	11
e	101	12

Upright characters, 9-pin		
Character	Code	Width
f	102	10
g	103	11
h	104	11
i	105	8
j	106	9
k	107	10
l	108	8
m	109	12
n	110	11
o	111	12
p	112	11
q	113	11
r	114	11
s	115	12
t	116	11
u	117	12
v	118	12
w	119	12
x	120	10
y	121	12
z	122	10
{	123	9
	124	5
}	125	9
~	126	12
none	127	none
ç	128	12
ü	129	11
é	130	12
â	131	12
ä	132	12
à	133	12
â	134	12
ç	135	11
ê	136	12

Upright characters, 9-pin		
Character	Code	Width
ë	137	12
è	138	12
ï	139	8
î	140	10
ì	141	8
Ä	142	12
Å	143	12
É	144	12
æ	145	12
Æ	146	12
ô	147	10
ö	148	10
ò	149	10
û	150	11
ù	151	11
ÿ	152	12
Ö	153	12
Ü	154	12
ç	155	11
£	156	12
¥	157	12
₤	158	12
f	159	11
á	160	12
í	161	8
ó	162	10
ú	163	11
ñ	164	11
Ñ	165	12
ª	166	12
º	167	12
¿	168	12
	169	12
¬	170	12
½	171	12
¼	172	12
ı	173	5
«	174	12
»	175	12
	176	12
	177	12
	178	12

Upright characters, 9-pin		
Character	Code	Width
	179	12
	180	12
	181	12
	182	12
	183	12
	184	12
	185	12
	186	12
	187	12
	188	12
	189	12
	190	12
	191	12
	192	12
	193	12
	194	12
	195	12
	196	12
	197	12
	198	12
	199	12
	200	12
	201	12
	202	12
	203	12
	204	12
	205	12
	206	12
	207	12
	208	12
	209	12
	210	12
	211	12
	212	12
	213	12
	214	12
	215	12
	216	12
	217	12
	218	12
	219	12
	220	12

Upright characters, 9-pin		
Character	Code	Width
	221	12
	222	12
	223	12
	224	12
ß	225	11
	226	10
	227	12
	228	10
	229	11
μ	230	11
	231	12
	232	10
	233	12
	234	12
	235	12
	236	12
	237	12
	238	10
	239	10
	240	12
±	241	12
	242	10
	243	10
	244	12
	245	12
÷	246	12
	247	12
°	248	8
·	249	6
·	250	6
	251	12
	252	8
²	253	8
	254	8
SP	255	12

Upright international characters, 9-pin		
Character	Code	Width
°	none	8
□	none	12
ß	none	11
¨	none	8
	none	12
Û	none	12
§	none	10
ü	none	11
é	none	12
ä	none	12
à	none	12
å	none	12
ç	none	11
ê	none	12
î	none	8
Ä	none	12
Å	none	12
É	none	12
æ	none	12
Æ	none	12
ö	none	10
ò	none	10
ù	none	11
Ö	none	12
Ü	none	12
£	none	12
¥	none	12
₣	none	12
ñ	none	11
Ñ	none	12
¿	none	12
¡	none	5

Italic characters, 9-pin		
Character	Code	Width
<i>SP</i>	32	12
<i>!</i>	33	10
<i>"</i>	34	10
<i>#</i>	35	12
<i>\$</i>	36	11

Italic characters, 9-pin		
Character	Code	Width
‰	37	12
&	38	12
'	39	5
(40	8
)	41	8
*	42	12
+	43	12
,	44	8
-	45	12
.	46	7
/	47	10
0	48	12
1	49	9
2	50	12
3	51	12
4	52	12
5	53	12
6	54	11
7	55	12
8	56	12
9	57	11
:	58	8
;	59	9
<	60	10
=	61	11
>	62	9
?	63	11
@	64	12
<i>A</i>	65	12
<i>B</i>	66	12
<i>C</i>	67	12
<i>D</i>	68	12
<i>E</i>	69	12
<i>F</i>	70	12
<i>G</i>	71	12
<i>H</i>	72	12
<i>I</i>	73	10
<i>J</i>	74	12
<i>K</i>	75	12
<i>L</i>	76	10

Italic characters, 9-pin		
Character	Code	Width
<i>M</i>	77	12
<i>N</i>	78	12
<i>O</i>	79	12
<i>P</i>	80	12
<i>Q</i>	81	12
<i>R</i>	82	12
<i>S</i>	83	12
<i>T</i>	84	12
<i>U</i>	85	12
<i>V</i>	86	11
<i>W</i>	87	12
<i>X</i>	88	12
<i>Y</i>	89	12
<i>Z</i>	90	12
[91	11
\	92	7
]	93	11
^	94	10
_	95	12
`	96	5
<i>a</i>	97	11
<i>b</i>	98	11
<i>c</i>	99	11
<i>d</i>	100	12
<i>e</i>	101	11
<i>f</i>	102	12
<i>g</i>	103	11
<i>h</i>	104	11
<i>i</i>	105	9
<i>j</i>	106	10
<i>k</i>	107	11
<i>l</i>	108	9
<i>m</i>	109	11
<i>n</i>	110	10
<i>o</i>	111	11
<i>p</i>	112	11
<i>q</i>	113	11
<i>r</i>	114	10
<i>s</i>	115	11
<i>t</i>	116	10

Italic characters, 9-pin		
Character	Code	Width
<i>u</i>	117	11
<i>v</i>	118	10
<i>w</i>	119	12
<i>x</i>	120	12
<i>y</i>	121	11
<i>z</i>	122	12
{	123	10
/	124	9
}	125	10
~	126	12
<i>none</i>	127	<i>none</i>
ç	128	12
ü	129	12
é	130	11
â	131	12
ä	132	11
à	133	11
å	134	11
ç	135	11
ê	136	12
ë	137	11
è	138	11
ï	139	10
î	140	11
ì	141	8
Ä	142	12
Å	143	12
É	144	12
æ	145	12
Æ	146	12
ô	147	12
ö	148	11
ò	149	11
û	150	11
ù	151	11
ÿ	152	11
Ö	153	12
Û	154	12
ç	155	11
£	156	11

Italic characters, 9-pin		
Character	Code	Width
¥	157	12
Ɔ	158	12
f	159	12
á	160	11
í	161	10
ó	162	12
ú	163	11
ñ	164	12
Ñ	165	12
ª	166	11
º	167	12
¿	168	11
	169	12
¬	170	12
½	171	12
¼	172	12
ı	173	10
«	174	12
»	175	12

Italic international characters, 9-pin		
Character	Code	Width
É	none	12
æ	none	12
Æ	none	12
ö	none	11
ò	none	11
ù	none	11
Ö	none	12
Û	none	12
£	none	12
¥	none	12
Ɔ	none	12
ñ	none	12
Ñ	none	12
¿	none	11
ı	none	10

Italic international characters, 9-pin		
Character	Code	Width
º	none	8
σ	none	12
β	none	11
¨	none	9
	none	12
Û	none	12
š	none	12
ü	none	12
é	none	11
ä	none	11
à	none	11
å	none	11
ç	none	11
ê	none	11
ï	none	8
Ä	none	12
Å	none	12

ASCII Code Table

	0	10	20	30	40	50	60	70	80	90	A0	B0	C0	D0	E0	F0
0	NUL		SP	0	@	P		p	NUL		SP	0	@	P		p
1		DC1		1	A	Q	a	q		DC1	!	!	A	Q	a	q
2		DC2		2	B	R	b	r		DC2	"	"	B	R	b	r
3		DC3	#	3	C	S	c	s		DC3	#	3	C	S	c	s
4		DC4	\$	4	D	T	d	t		DC4	\$	4	D	T	d	t
5			%	5	E	U	e	u			%	5	E	U	e	u
6			&	6	F	V	f	v			&	6	F	V	f	v
7	DEL			7	G	W	g	w	DEL			7	G	W	g	w
8	BS	CAN	(8	H	X	h	x	BS	CAN	(8	H	X	h	x
9	HI	EM)	9	I	Y	i	y	HI	EM)	9	I	Y	i	y
A	LF		*	:	J	Z	j	z	LF		*	:	J	Z	j	z
B	VT	ESC	+	;	K	[k	{	VT	ESC	+	;	K	[k	{
C	FF		<		L	\	l		FF		<		L	\	l	
D	CR		=		M]	m	}	CR		=		M]	m	}
E	SO		>		N	^	n	~	SO		>		N	^	n	~
F	SI		/	?	O	_	o	DEL	SI		/	?	O	_	o	DEL

*Codes in shaded boxes are printer control codes.

Parallel Interface

EPSON printers feature an industry standard Centronics Parallel type interface. The printer side of this interface utilizes a 36 Pin connector. The pin assignments for this connector are as follows:

Pins and signals

Signal Pin	Return Pin	Signal	Direction	Description
1	19	$\overline{\text{STROBE}}$	IN	STROBE pulse to read data. Pulse width must be more than 0.5 microseconds at the receiving terminal.
2	20	DATA 1	IN	These signals represent information of bits 1 to 8 of parallel data, respectively. Each signal is at HIGH level when data is logical 1 and LOW when it is logical 0.
3	21	DATA 2	IN	
4	22	DATA 3	IN	
5	23	DATA 4	IN	
6	24	DATA 5	IN	
7	25	DATA 6	IN	
8	26	DATA 7	IN	
9	27	DATA 8	IN	
10	28	$\overline{\text{ACKNLG}}$	OUT	About an 11-microsecond pulse. LOW indicates that data has been received and that the printer is ready to accept more data.
11	29	BUSY	OUT	A HIGH signal indicates that the printer cannot receive data. The signal goes HIGH in the following cases: 1) During data entry (ea. char. time) 2) During a printer-error
12	30	PE	OUT	A HIGH signal indicates that the printer is out of paper.
13	—	SLCT	OUT	Always at high level when the printer is on.
14	—	$\overline{\text{AUTO}}$ $\overline{\text{FEED XT}}$	IN	When this signal is LOW, the paper is automatically fed 1 line after printing. (The signal level can be fixed to LOW by setting the DIP switch or SelectType. See the user's guide of each printer.)

Pins and signals (continued)

Signal Pin	Return Pin	Signal	Direction	Description
15	—	NC	—	Not used.
16	—	GND	—	Logic ground level.
17	—	CHASSIS GND	—	Printer's chassis ground, which is isolated from the logic ground.
18	—	NC	—	Not used.
19–30	—	GND	—	Twisted-pair return signal ground level.
31	16	$\overline{\text{INIT}}$	IN	When this level becomes LOW, the printer controller is reset to its power-up state and the print buffer is cleared. This level is normally HIGH; its pulse width must be more than 50 microseconds at the receiving terminal.
32	—	$\overline{\text{ERROR}}$	OUT	This level becomes LOW when the printer is: 1) In paper out state. 2) In error state.
33	—	GND	—	Same as for Pins 19-30.
34	—	NC	—	Not used.
35	—	—	OUT	Pulled up to 5V through 3.3 k Ω resistance.
36	—	$\overline{\text{SLCT IN}}$ or NC	IN or —	The DC1/DC3 code is valid only when this $\overline{\text{SLCT IN}}$ signal is HIGH. (Internal fixing can be carried out with the jumper switch. The level of this signal is factory-set to LOW.) Some printers do not use this function. For specific information, see the user's guide of each printer.

Note:

- The values may vary from printer to printer. See the user's guide of your printer.
- The column heading "Direction" refers to the direction of signal flow as viewed from the printer.
- "Return" denotes the twisted-pair return, to be connected at signal ground level. For the interface wiring, be sure to use a twisted-pair cable for each signal and to complete the connection on the return side. To prevent noise, these cables should be shielded and connected to either the chassis of the host computer or the printer (but not at both ends).
- All interface conditions are based on TTL level. Both the rise and the fall times of each signal must be less than 0.2 microseconds.
- Data transfer must be carried out by observing the ACKNLG or BUSY signal. (Data transfer to this printer can be carried out only after receipt of the ACKNLG signal or when the level of the BUSY signal is LOW.)

Parallel interface timing

9-pin printers (excluding MX-series, and LX-300 and later printers)

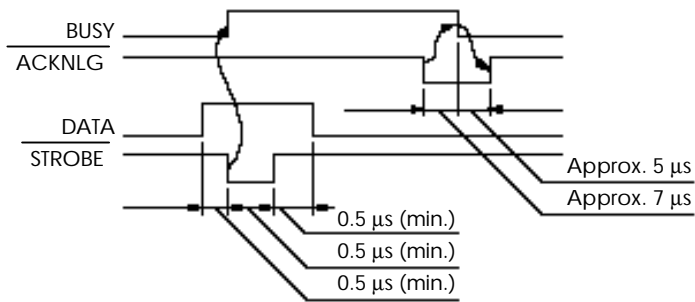

24/48-pin printers (excluding LQ-1500, SQ-2000, and LQ-300 and later printers)

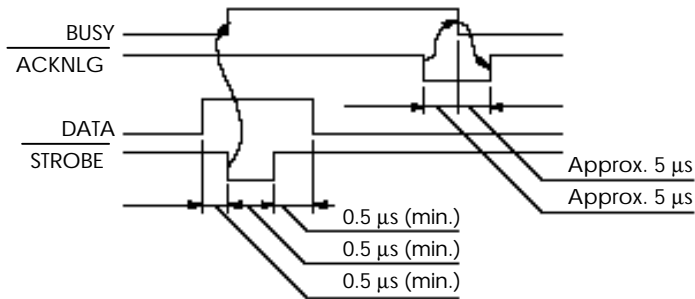

MX-series printers

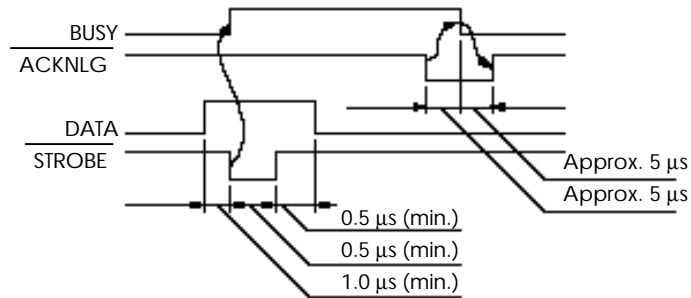

LQ-1500, SQ-2000

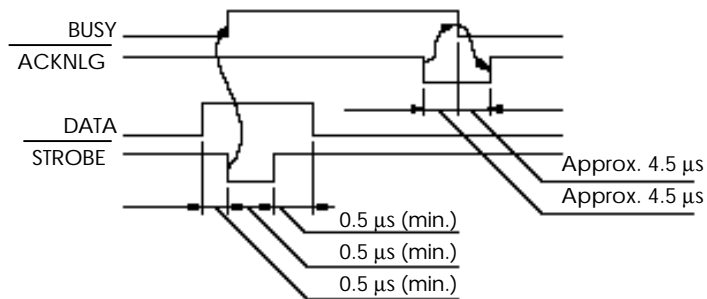

LX-300 and later 9-pin printers, and LQ-300 and later 24/48-pin printers

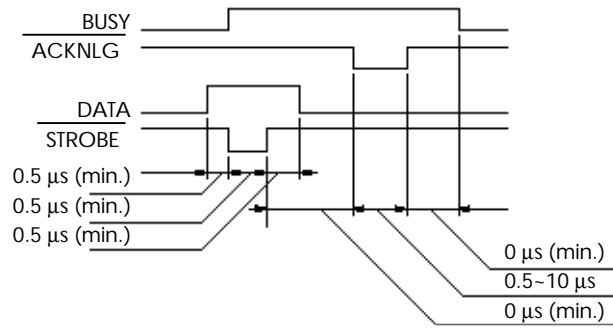

The flow chart shown below illustrates the recommended procedure for checking the status of a parallel interface.

Parallel interface flow chart

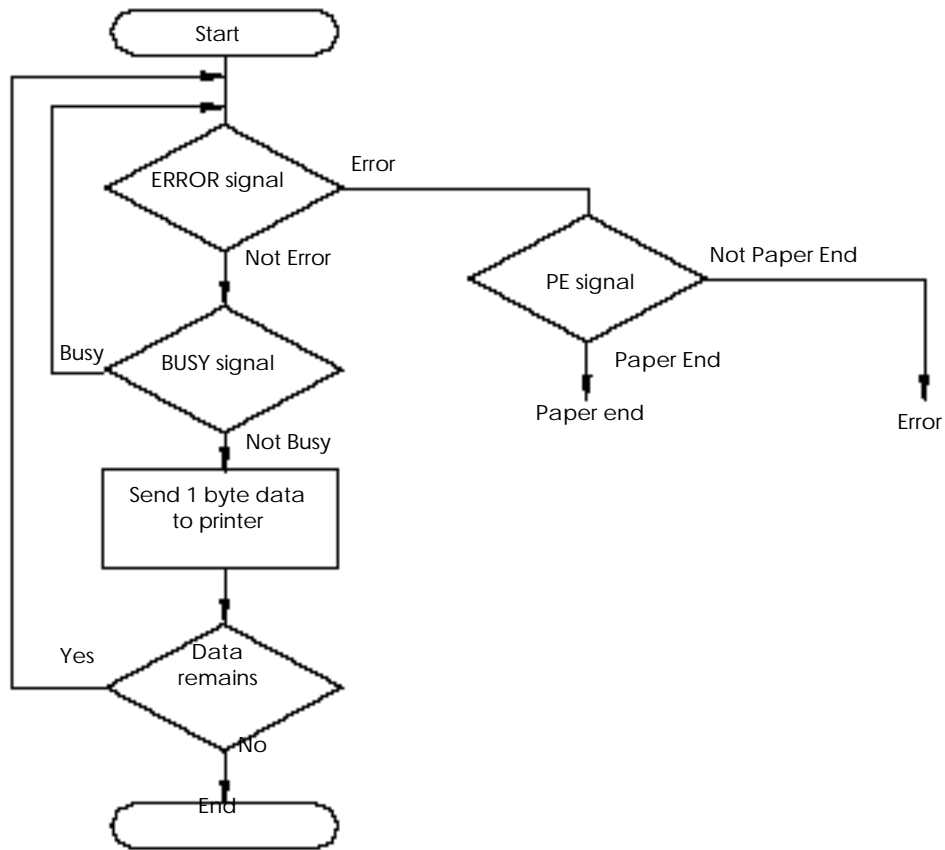

Internal Serial Interface

Six-pin DIN connector type

Connector pin assignment

Pin Number	Signal	Signal Dir.	Description
1	TXD	Out	Transmits data for Xon/Xoff
2	REV	Out	Whether or not the printer is ready to receive data
3	RXD	In	Receive data
4	NC	—	Not Used
5	SG	—	Signal Ground
6	FG	—	Frame Ground

Synchronization Asynchronous

Data format 1 start bit
Data word length: 8 bits
Odd, even, or no parity
1 stop bit

Baud rate 300-19,200 bps, depending on printer

Signal level Mark (1) -3V to -27V
Space (0) +3V to +27V

Handshaking Handshaking by DTR signal or X-on/X-off. When the number of free bytes in the input buffer drops below 256, the DTR signal changes to “mark”, signifying the printer is not ready to receive data. When the number of free bytes rises above 528, the DTR signal changes to “space,” specifying that the printer is now ready to receive data.

25-pin subminiature D-shell connector (female) type

Connector pin assignment

Pin Number	Signal	Signal Dir.	Description
2	TXD	Out	Transmits data for Xon/Xoff
20	DTR	Out	Indicates that the printer is ready to receive data or not.
11	REV	Out	Connected directly to the DTR signal
4	RTS	Out	Request to send. Always SPACE level when the printer is powered on. Pulled up to +12V via 4.7Kohm resistor.
3	RXD	In	Receive data
7	SG	—	Signal Ground
1	FG	—	Frame Ground
Other	NC	—	Not Used

Synchronization Asynchronous

Data format 1 start bit
Data word length: 7 or 8 bits
Odd, even, or no parity
1 stop bit

Baud rate 300-19,200 bps, depending on printer

Signal level EIA-232D Mark (1) -3V to -25V
Space (0) +3V to +25V

Handshaking **DTR signal and XON/XOFF**
The DTR signal is MARK and an XOFF code (DC3, 13H) is transmitted when the available input buffer space drops to 256 bytes. The DTR signal is SPACE and an XON (DC1, 11H) is transmitted when the available input buffer space returns to 256 bytes.

ETX, ACK/NAK d

At the time the printer receives an ETX (03H) command, if the available buffer space is more than 256 bytes, the printer sends an ACK (06H) code in reply, or if the available buffer space is less than 256 bytes, the printer sends NAK (15H) and "d" (64H) codes continuously. The ETX-ACK handshaking protocol can be enabled or disabled altering the default settings.

Error handling When a parity error is detected, the received byte is changed to the "*" character code. Overrun errors and framing errors are ignored.

Optional Serial Interfaces

Several optional serial interfaces are offered for the EPSON printer line. The pin assignments and signal direction from the printer side of the Female DB-25 are described in the table below:

Optional serial interface pin assignments

Pin	Signal Name	Dir.	Description
1	Protective Ground	n/a	Chassis Ground
2	Transmitted Data (TXD)	Out	Transmitted Data
3	Received Data (RXD)	In	Received Data
6	Data Set Ready (DSR)	In	This signal must be at the positive EIA level for the printer to receive data.
7	Signal Ground	In	Return path for data and control signals
8	Data Carrier Detect (DCD)	In	This is the same signal as DSR at pin #6, DCD and DSR can be held at "SPACE" internally. The signal polarity is factory set to "SPACE"
11	Reverse Channel	Out	This signal is at the positive EIA level when the printer is ready to accept data entry, and at the negative EIA (= 2nd RTS) level when the printer is not ready. The user can invert the polarity of this signal via DIP switch.
17	TTY-TXD	Out	Low impedance ("MARK") between pins 17 and 24 or X-ON signal sent across pins 17 and 24 indicates that the printer is ready to accept data. High impedance ("SPACE") or X-OFF signal being sent indicates that the printer is busy. The operator can invert the polarity via DIP switch.
20	Data Terminal Ready (DTR)	Out	See Pin 11 for description
23	TTY-TXD Return	n/a	
24	TTY-TXD Return	n/a	See Pin 17 for description
25	TTY-RXD	In	Input data when using serial current loop.

Selecting PreESC/P 2 Fonts in ESC/P 2 Multipoint Mode

ESC/P 2

You can use the ESC X command to select fonts identical to those available in non-ESC/P 2 printers. Send the ESC X parameters on the right to obtain the point and pitch sizes selected by the commands on the left.

	SO	SI	ESC w 1	Point	Pitch	ESC X		
						m	nL	nH
ESC P				10.5	10	36	21	0
	✓			10.5	5	72	21	0
		✓		10.5	17.14	21	21	0
			✓	21	10	36	42	0
	✓	✓		10.5	8.57	42	21	0
	✓		✓	10.5	5	72	21	0
		✓	✓	21	17.14	21	42	0
	✓	✓	✓	21	8.57	42	42	0
ESC M				10.5	12	30	21	0
	✓			10.5	6	60	12	0
		✓		10.5	20	18	21	0
			✓	21	12	30	42	0
	✓	✓		10.5	10	36	21	0
	✓		✓	10.5	6	60	21	0
		✓	✓	21	20	18	42	0
	✓	✓	✓	21	10	36	42	0
ESC g				10.5	15	24	1	0
	✓			10.5	7.5	48	21	0
		✓		10.5	15	24	21	0
			✓	21	15	24	42	0
	✓	✓		10.5	7.5	48	21	0
	✓		✓	10.5	7.5	48	21	0
		✓	✓	21	15	24	42	0
	✓	✓	✓	21	7.5	48	42	0
ESC p				10.5	Prop.	1	21	0
			✓	21	Prop.	1	42	0

Glossary

application program (software)

A program designed to perform a specific function. Examples are word processing, spreadsheet, and database programs.

ASCII

The American Standard Code for Information Interchange. ASCII codes are assigned to particular characters and control codes used in operating computers and printers. The ASCII code table is included in the Appendix.

attribute byte(s)

Parameters used when defining user-defined characters. Depending on the type of printer, the attribute byte can determine the width of a character, beginning and ending columns, and which pins to use in the print head.

automatic tear off

A printer feature that feeds the last page of a print job on continuous paper to a position where paper can be conveniently torn off. When more print data is sent, the paper feeds back to the loading position and begins printing on the following page. This feature is only available when using a push tractor.

bar code

A group of vertical bars and spaces with varying widths that represent numbers and letters. Bar codes are usually used to identify items such as commercial goods, products, and books.

baseline

The imaginary line where the bottom of characters such as A and b are printed (descenders on characters such as g or y descend below the baseline). The baseline on 24-pin printers is located 20/180 inch below the print position; on 9-pin printers, 7/72 inch below the print position.

baud rate

The rate at which data is transferred from one machine to another. The baud rate is adjustable when using a serial interface. Some printers allow adjustment by DIP switch.

bidirectional printing

Printing in which the print head prints in both directions. This method increases the speed of printing. See *high speed printing*.

binary

The base 2 number system. All numbers are represented by a 1 or 0.

binary command mode

A subset of binary printer commands used to control compressed raster graphics printing in the extended raster graphics mode. These commands are available only in ESC . 2 TIFF compressed mode.

bit

A digit (equal to 1 or 0) in the binary number system. A byte of data consists of 8 bits.

bit-image graphics

Graphics composed of a series of dots, printed in vertical columns. The number of dots in the columns depends on the number of dots in the print head. Dots are printed for each bit that equals one.

bold

The font weight that produces characters with thicker lines, making them appear darker.

buffer

The portion of the printer's memory used to store data before printing it. The buffer size can be changed on some printers.

byte

A unit of information consisting of eight bits, representing any value between 0 and 255 (decimal). All data is sent to the printer in bytes.

carriage return

A command (CR) that moves the print position to the left-margin position.

character

A symbol used in a writing system (an alphabet letter, a numeral, or a punctuation mark) or as a component of graphics (a box-drawing character, graphic symbol, or a user-defined character).

character code

A value between 0 and 255 that is assigned to a specific character in the current character table.

character set

A collection of letters, numbers, and symbols that provides you with the characters used in a particular language.

character spacing

The horizontal placement of characters. Two types of character spacing are available: fixed-pitch and proportional spacing.

character table

A collection of up to 256 characters that can be represented by a one-byte character code. EPSON printers produced after 1990 feature a large number of character tables, each representing a particular language, that can be selected by command (ESC/P 2 printers) or DIP switch (non-ESC/P 2 printers).

character traits

Essential characteristics shared by characters in RAM memory (including user-defined characters). Only characters with the same traits can be saved in RAM at the same time.

characters per inch (cpi)

A measure of the size of text characters, sometimes referred to as pitch.

characters per second (cps)

The theoretical measure of the number of characters that can be printed per second on a single line.

CMYK

Cyan (blue-green), magenta, yellow, and black. These colored inks, also known as process colors, are used to create the subtractive system array of printed colors.

compression

A method of reducing the amount graphics data sent to the printer during raster graphics printing. In standard compressed raster graphics, two bytes of data (a counter byte and a data byte) can specify up to 1,016 dots. Also, repetitive and nonrepetitive data can be sent in the same data string. See also *TIFF compressed mode*.

condensed printing

Printing in which the characters are spaced approximately 40% to 50% closer than normal. Useful for fitting wide tables or spreadsheets onto the paper.

continuous paper

Paper that has sprocket-feed holes on each side, is perforated between pages, and comes in a folded stack. Also called fanfold paper.

control code

Special codes used to control printer functions, such as performing a carriage return or line feed. Many control codes also have characters assigned to them; you can print these characters after using commands to change from control-code to character printing.

cpi

See *characters per inch*.

cps

See *characters per second*.

cut sheets

See *single-sheet paper*.

cut-sheet feeder

A device that automatically feeds single sheets of paper into the printer.

decimal

A number expressed in powers of 10. The decimal system uses base 10, in which all numbers are represented by the digits 1 to 9, with 0 used as a place holder.

default

The value or setting that is in effect when a printer is turned on, reset, or initialized. Defaults are sometimes affected by DIP-switch or panel setting.

DIP switch

Stands for dual in-line package switch. Small switches included on most printers used for selecting various features or default settings.

dot matrix

A method of printing in which each character is formed by printing a pattern (matrix) of dots based on the number of dots in the print head.

dots per inch (dpi)

Measures the resolution of an image. See also *resolution*.

double-height printing

Printing in which each character is twice as tall as normal.

double-strike printing

A print enhancement that produces darker-than-normal characters. The print head passes over the paper twice, double-printing the characters.

double-width printing

Printing in which each character is twice as wide as normal.

downloaded characters

See *user-defined characters*.

dpi

See *dots per inch*.

draft printing

A method of printing in which fewer dots are used to form characters. Characters print faster, but have a rougher appearance.

driver

A program used to send commands and transfer data from the computer to the printer. Most application programs include drivers that support EPSON printers.

ESC/P

Abbreviation for EPSON Standard Code for Printers, a system of commands that lets you control your printer using your computer's software. The system is standard for all EPSON printers and is supported by most software programs for personal computers.

ESC/P 2

The enhanced version of the ESC/P printer command language. Commands in this language provide the printer with laser-like features, such as scalable fonts and enhanced graphics printing.

fixed-pitch printing

A type of letter spacing in which characters are printed at equal intervals. Pitch is measured in characters per inch.

font

A complete set of characters or symbols that share the same size and style. In computer terminology, the term font has become confused with typeface to mean the entire family of type including all the sizes and styles.

font cartridges

Options that provide your printer with additional typefaces.

form feed

A control code or control panel button (on most printers) that advances the paper to the next top-of-form position.

graphics

Groups of dots or characters that are used to create a design or image.

graphics mode

The mode in which raster graphics printing is possible. Characters cannot be printed during graphics mode, and character-related commands are ignored.

hexadecimal

The base 16 number system. All numbers are represented by the following numerals: 0, 1, 2, 3, 4, 5, 6, 7, 8, 9, A, B, C, D, E, F. A byte can be defined by any two-digit hexadecimal number.

high-speed draft

A printing mode that uses a minimum number of dots per character to attain extremely high printing speeds.

high-speed printing

Characters are printed in both directions for faster printing

HMI

See *horizontal motion index*.

horizontal motion index (HMI)

A setting that determines the fixed distance to move the horizontal position when printing characters. HMI is measured in inches instead of characters per inch.

initialization

Returns the printer's settings to their original values, or defaults.

INT

The integer (whole number) part of a number. For example, INT(1.8) is 1.

interface

The connection between the printer and the computer. A parallel interface transmits data one character or code at a time, and a serial interface transmits data one bit at a time.

international character set

A set of up to 12 particular characters that corresponds to symbols used in various countries. Each set is referred to by that country's name or language.

italics

The font style in which printed characters slant to the right; also called oblique.

justification

Horizontal alignment of printed text to the left, right, or center of the printing area. Full justification aligns text to both the left and right margins.

Letter Quality (LQ)

A method of printing in which a higher number of dots is used to form characters. Characters print slower but have a more fully-formed appearance.

line feed

A control code or control panel button (on most printers) that advances the paper one line.

line spacing

The distance the vertical print position moves when a LF command is sent.

loading position

The position to which the paper is automatically loaded.

logical page

The settings within the printer concerning the page format.

low nibble

The lower four bits in a data byte (eight bits).

LQ

See *Letter Quality*.

LSB

Least significant bit. The right-most digit in a binary number; the binary digit with the smallest value in a byte.

margin

The area between the edge of the paper and the margin position, whether top, bottom, left, or right. (The top margin can be set on ESC/P 2 printers only.)

margin position

The position of the inner edge of the margin, whether top, bottom, left, or right.

memory

The part of the printer where character information and data are stored.

MicroWeave

Printing in which images are printed in finer increments to reduce the possibility of banding—uniform horizontal lines in graphics—usually associated with serial printers.

MOD

The remainder of a division operation (modulo). For example, dividing 9 by 5 results in 1, with a remainder of 4; so MOD(9÷5) is 4.

MSB

Most significant bit. The left-most digit in a binary number; the binary digit in a byte with the highest value.

multipart forms

Preprinted forms that are two or more sheets thick. Sheets are fastened together so that printing is duplicated on each sheet.

multipoint mode

The mode in which printing of scalable fonts is possible.

Near-Letter Quality (NLQ)

The highest print quality available on 9-pin printers, obtained by using more dots to print characters. Characters print slower but have a more fully formed appearance.

NLQ

See *Near-Letter Quality*.

Parallel interface

An interface that transfers data one byte at a time.

parity

A method for detecting errors during data transmission through a serial interface.

pitch

The font attribute that determines the placement of printed characters. Two types of pitch are available: fixed pitch (characters are printed at equal intervals) or proportional pitch (character placement varies, depending on character width information).

point size

A measure of character height. One point equals 1/72 inch. In ESC/P 2, point size can be set as a font attribute.

print data

Data that causes the printer to actually print characters or graphics. Data that sets the page format, selects printing modes, or changes printer settings is not considered print data.

print job

A collection of data that has a beginning and end, and is sent to the printer in a continuous stream. A standard print job should be composed of one or more pages and should begin and end with an ESC @ (initialize printer) command, with all pages (including the last) ending in a FF command.

printable area

The area of the page on which the printer can print. This area is smaller than the physical size of the page.

printing area

The area of the page within the margins, where printing actually occurs. The printing area is equal to or less than the printable area.

proportional spacing

A type of pitch in which character placement varies, depending on character width information.

pull tractor

A tractor that “pulls” continuous paper through the printer from the exit side.

push tractor

A tractor that “pushes” continuous paper through the printer from the loading side.

RAM

Random access memory. The portion of the printer’s memory used as a buffer and for storage of user-defined characters. RAM memory is lost when you turn off, reset, or initialize the printer.

raster graphics

A type of graphics in which data is sent in one-dot high lines; the printer reorganizes the data internally to correspond to the print head layout. Raster graphics are available only on printers featuring ESC/P 2.

ROM

Read only memory. The portion of the printer’s memory where the printer’s operating system and built-in character data are stored. You cannot erase or modify ROM memory.

RGB

Red, green, and blue. These colors, in phosphors radiated by the computer monitor's electron gun, are used to create the additive system array of screen colors.

reset

Returning the printer's settings to their original values, or defaults. Performed by sending a command or an $\overline{\text{INIT}}$ signal, or by turning the printer off and then back on.

resolution

The number of dots per inch used to represent an image.

roll paper

Paper that comes in rolls and that can be fed through the printer when an optional roll-paper holder is attached.

scalable font(s)

A font that can be selected on the basis of the point size and is available in specific increments over a wide range of values. Scalable fonts are available only on printers featuring ESC/P 2.

SIDM

Serial, impact, dot-matrix. Printers that process data line by line, and form characters by striking small pins against a ribbon that in turn strikes the paper.

SNIJ

Serial, non-impact, ink jet. Printers that process data line by line, and form characters by transferring ink dots onto paper through small ink jets.

single-sheet paper

Single, unconnected sheets of paper that can be fed into the printer by hand, by cut-sheet feeder, or by paper cassette.

style

The font attribute that determines whether or not characters are printed at a slant. Two style settings are available: italics and normal.

subscript

Printing in which each character is printed at about two-thirds the normal height, in the lower part of the character space.

subtractive colors

Colors produced by pigments that absorb some colors of light and reflect others. See also *CMYK*.

superscript

Printing in which each character is printed at about two-thirds the normal height, in the upper part of the character space.

TIFF compressed mode

Extended raster graphics compression mode available on the Stylus COLOR and later printer models. This mode uses TIFF (Tagged-Image File Format) compression.

tof

See *top-of-form*.

throughput

A measure of the number of printed pages per minute that can be produced by a printer.

top-of-form

The first printable vertical position on the paper. Programs should be written so the actual top-of-form position matches the printer's top-of-form setting.

typeface

Refers to a set of characters or symbols that share a common design. Typefaces are referred to by family names such as Roman, Prestige, or Script. In computer terminology, the term typeface is often used interchangeably with font.

unidirectional printing

Printing in one direction only. Unidirectional printing is useful for printing graphics because it allows more precise vertical alignment than bidirectional printing.

user-defined characters

Custom characters that you define and store in RAM memory. By switching to RAM character printing, you can print user-defined characters just as you would normal characters. Also known as downloaded characters.

weight

The font attribute that determines the thickness of the lines composing each character. Two weight settings are bold and normal.

Index

A

ASCII

- code table, 3, A-30
- codes, 3, A-30
- order, C-6

Assign character tables, C-73–C-76

Attribute byte

- for 9-pin draft characters, C-87, R-32
- for 9-pin LQ characters, C-87, R-34

Attributes, font, C-118–C-120, R-42

B

Band height, R-75, R-77–R-78, R-99, R-101

Banding, 1, C-171, R-99

Bar code, C-195–C-197, R-84

Baseline, C-12, R-8, R-21, R-56, R-60

Baud rate, A-35, A-36

Bidirectional printing, C-159–C-162, R-55

Bin, loading paper from cut-sheet feeder, C-157–C-158

Binary mode commands, C-5, C-8, C-216, R-74, R-99, R-102

Bit assignments for binary mode, R-102

Bit-image

- dot density, R-66–R-68
- preparing, R-68

Bit-image graphics

- printing, C-177–C-180, R-66–R-72
- raster graphics and, R-65
- sending, R-70–R-71
- text printing with, R-4, R-64, R-71–R-72

Bold

- canceling, C-112–C-113
- selecting, C-110–C-111, R-51

Bottom margin

- canceling, C-19–C-20
- point size and, R-8, R-60
- position, R-8, R-60
- printing area and, R-5
- setting, C-11–C-12, C-17–C-18, R-13

Byte

- attribute, C-87
- attribute for 9-pin draft characters, R-32
- attribute for 9-pin LQ characters, R-34
- bit-image data, R-70–R-71
- counter, R-81
- data, R-67, R-75, R-81

C

Carriage return, C-25–C-26

Carriage return in binary mode, C-221

Character

- height, C-97, C-100–C-105, R-45
- pitch, C-97, R-48
- point, R-45, R-48
- spacing, C-99
- traits, R-17, R-19

- width, C-99
- Character sets, international, C-80–C-83, R-41
- Character size
 - 10.5-point, 10-cpi, C-100
 - 10.5-point, 12-cpi, C-102
 - 10.5-point, 15-cpi, C-104
- Character tables
 - assigning, C-73–C-76, R-4, R-15–R-16
 - graphics, C-78, C-79, R-15
 - italics, C-78, C-79, R-15
 - selecting, C-77–C-79, R-44
- Characters
 - copying to RAM, C-89–C-90, R-24
 - download, R-17
 - printing data as, C-150
 - selecting, R-15
 - space between, C-108–C-109
 - switching to normal, C-91–C-92
 - switching to user-defined, C-91–C-92
 - user-defined, C-84–C-88, R-17, R-19, R-22
- Characters per inch (dpi)
 - 10 dpi, C-100–C-101
 - 12 dpi, C-102–C-103
 - 15 dpi, C-104–C-105
 - fixed pitches, R-49
 - multipoint mode, R-43–R-44
- Color
 - ink jet printer, R-101
 - multipoint font, R-100
 - raster graphics, R-101
 - selecting, C-193–C-194, R-55–R-56
 - selecting in binary mode, C-220
- Commands
 - binary mode, C-5, C-8, C-216, R-74, R-99, R-102
 - deleted, 3, C-5
 - graphics mode, R-74
 - names, 3
 - nonrecommended, 3
 - order, recommended, R-4
 - parameters, 3
 - sorted by ASCII order, C-6
 - sorted by function order, C-2
- Compressed mode
 - exiting, C-222
 - extended raster graphics, R-83
 - Run Length Encoding (RLE), C-172, R-75, R-99
 - standard raster graphics, R-81–R-82
 - TIFF, C-175–C-176, R-83
- Compression, C-172, C-175, R-83, R-101
- Condensed printing
 - canceling, C-138–C-139
 - modifying point size and pitch, R-43–R-44
 - selecting, C-134–C-137
 - setting margins and, R-9
- Continuous paper
 - moving vertical print position, R-63
 - printable area, R-6
 - printing area, R-7
 - top/bottom margin, R-63
- Control codes
 - in code table, A-30
 - printing, C-155

- upper codes treated as control codes, C-153–C-154
- upper codes treated as printable characters, C-151–C-152
- Copying characters to RAM, C-89–C-90, R-24
- Counter
 - data-length, R-81–R-82
 - repeat, R-81–R-82
- cpi. *See* Characters per inch.
- Cut-sheet feeder
 - paper handling with, C-157–C-158
 - printing area, R-5, R-7

D

- Data-length counters, R-81–R-82
- Default unit, C-50, R-5, R-11, R-13, R-57
- Deleted commands, 3, C-5
- Dot columns of bit-image graphics, R-67
- Dot density
 - of bit-image graphics, R-67
 - of raster graphics, R-75
- Dot-matrix printer, 1
- Double-height, C-148–C-149, R-43–R-44
- Double-strike
 - canceling, C-123–C-124, R-51
 - selecting, C-121–C-122, R-51
- Double-width, R-43–R-44
 - canceling for one line, C-144–C-145
 - printing on/off, C-146–C-147
 - selecting for one line, C-140–C-143
- Download characters, R-17
- Draft
 - printing, C-93–C-94, R-43
 - user-defined characters, R-19

E

- Ejecting paper, C-157–C-158
- Enhancements
 - double-height, C-148–C-149
 - Double-strike, C-121–C-122, C-123–C-124, C-140–C-143, R-51
 - double-width, C-144–C-145, C-146–C-147
 - outline, C-133, R-52
 - score, C-127–C-128, R-53
 - selecting, C-118–C-120
 - shadow, C-133, R-52
- ESC/P
 - 24/48-pin, 2, C-9
 - 9-pin, 2, C-9
 - printer control language, 1
- ESC/P 2
 - 24/48-pin, 2, C-9
 - extended, R-99
 - printer control language, 1
 - programming guide, R-99
- Extended raster graphics, R-65, R-83, R-99

F

- Fixed-pitch, user-defined characters and, R-19
- Fonts
 - attributes, C-118–C-120, R-42
 - scalable, R-43

- selecting, R-42
- standard, R-43

Form feed, C-29–C-30

Full graphics mode, C-169, C-172, R-75, R-80

G

Graphic character table, C-78, C-79, R-15

Graphics

- bit-image, C-177–C-180, R-65, R-66–R-72
- raster, R-65, R-73–R-83
- text printing with, R-4

Graphics mode

- commands available, R-74
- entering, R-73
- exiting, R-73
- extended raster, R-83
- full, C-169, C-172, R-75, R-80

H

Height, character

- commands affecting, C-97, C-100–C-105
- selecting point size, R-45
- user-defined characters and, R-19

High nibble value, R-103

HMI. *See* Horizontal motion index.

Horizontal dot density

- of bit-image graphics, R-67
- of raster graphics, R-75

Horizontal motion index, C-99, R-49

Horizontal position in binary mode

- setting 1-dot unit for, C-224
- setting 8-dot unit for, C-223
- setting relative, C-218

Horizontal print position

- absolute, C-31–C-32
- graphics, R-57
- moving, R-57–R-59
- moving to the next tab, C-43–C-44
- relative, C-33–C-36
- text, R-57

Horizontal tab, C-61–C-62, R-57, R-59

I

Icons, 2, C-9

Initialize, C-198–C-199, R-4, R-73

Ink jet printer, R-73, R-99, R-101

INT, 4

Intercharacter space, C-108–C-109

Interface specifications

- optional, A-37
- parallel, A-31
- serial, A-35

International character sets, C-80–C-83, R-41

Italic character table, C-77, C-79, R-15

Italics

- canceling, C-116–C-117, R-50
- selecting, C-114–C-115, R-50

J

Justification, C-71–C-72

L

Left margin

- printing area and, R-5
- setting, C-23–C-24, R-9

Letter Quality

- printing, C-93–C-94, R-43
- typeface, C-95–C-96
- user-defined characters, R-19

Line drawing, C-127–C-128

Line feed, C-27–C-28, R-62

Line spacing

- graphics with, R-70
- setting 1/6 inch, C-53
- setting 1/8 inch, C-51–C-52
- setting 7/72 inch, C-60
- setting n/180 inch, C-55
- setting n/216 inch, C-56
- setting n/360 inch, C-57
- setting n/60 inch, C-58
- setting n/72 inch, C-59

Loading paper, C-157–C-158

Low nibble value, C-217, C-218, C-219, R-103

LQ. *See* Letter Quality.

M

Margin

- bottom, C-17–C-18, C-19–C-20, R-13
- left, C-23–C-24, R-9
- printing area and, R-5
- right, C-21–C-22, R-9
- top/bottom, C-11–C-12, R-13

Master select, C-118–C-120, R-49

MicroWeave, C-171, R-99, R-101

MOD, 4

Moving print position

- absolute horizontal, C-31–C-32
- absolute vertical, C-37–C-38
- horizontal, R-57–R-59
- relative horizontal, C-33–C-36
- relative vertical, C-39–C-40
- to the next horizontal tab, C-43–C-44
- to the next vertical tab, C-45–C-46
- vertical, C-41–C-42, R-60

Multipoint mode

- commands ignored during, C-98, R-44
- commands that cancel, C-98, R-44
- entering, C-97–C-98, R-43, R-45
- proportional width in, A-21
- standard fonts in, A-38

N

Near-Letter Quality

- printing, R-43

Nibble value, C-217, C-218, C-219, R-103

Noncompressed mode, C-172

Nonrecommended commands, 3

Normal characters, switching to, C-91–C-92

O

Optional interface specifications, A-37

Outline, C-133, R-52

Overscore, C-127, R-53

P

Page format to set top and bottom margins, C-11–C-12

Page length

printing area and, R-5, R-11

setting, R-10

setting in defined unit, C-10

setting in inches, C-15–C-16

setting in lines, C-13–C-14

Paper

moving vertical print position, R-63

printable area, R-6–R-7

Parallel interface specifications, A-31

Pitch

10 cpi, C-100–C-101

12 cpi, C-102–C-103

15 cpi, C-104–C-105

adjusting, R-50

font selection by, R-43–R-44

selecting, C-97, C-99, R-48

setting margins and, R-9

Point

character height, R-45

font selection by, R-43–R-44

selecting, C-97, R-48

top/bottom margins and, R-8, R-60

Print position

absolute horizontal, C-31–C-32

absolute vertical, C-37–C-38

advancing vertically, C-41–C-42

for graphics printing, R-56

for text printing, R-56

horizontal, R-57–R-59

moving to the next horizontal tab, C-43–C-44

moving to the next vertical tab, C-45–C-46

relative horizontal, C-33–C-36

relative vertical, C-39–C-40

vertical, R-60–R-63

Print quality

draft or LQ, C-93–C-94, R-43

Printable area, R-6, R-60

Printing area

for continuous paper and single-sheet paper, R-7

for text and graphics, R-8

setting, R-5

Printing direction

bidirectional, C-159–C-162, R-55

unidirectional, C-159–C-162, R-55

Programming guide to extended ESC/P 2, R-99

Proportional spacing

modifying point size and pitch, R-43

selecting, R-45, R-48, R-50

setting margins and, R-9

turning on and off, C-106–C-107

user-defined characters and, R-19

width tables, A-21

R

RAM

- characters, R-17, R-24
- copying ROM characters to, C-89–C-90, R-24
- switching to, R-36

Random Access Memory. *See* RAM.

Raster graphics

- bit-image graphics and, R-65
- compressed mode, C-172, R-81–R-82
- extended, R-65, R-83
- MicroWeave, C-171
- noncompressed mode, C-172
- printing, C-172, R-73–R-83
- RLE, C-172
- selecting graphics mode to print, C-169
- standard, R-65, R-74
- TIFF, C-175–C-176
- transferring in binary mode, C-217

Read Only Memory. *See* ROM characters.

Recommended

- command order, R-4
- user-defined character size, R-19

Repeat counters, R-81–R-82

Right margin

- printing area and, R-5
- setting, C-21–C-22, R-9

ROM characters

- copying to RAM, C-89–C-90, R-24
- user-defined characters and, R-17, R-24

Run Length Encoding (RLE), C-172, R-75, R-99

S

Scalable fonts, R-43

Scoring, C-127–C-128, R-53

Sending print data efficiently, R-64

Serial interface specifications, A-35

Shadow, C-133, R-52

Single-sheet paper

- loaded from cut-sheet feeder, R-5
- loaded manually, R-5
- moving vertical print position, R-63
- printable area, R-6
- printing area, R-7

Space between characters, C-108–C-109

Specifications

- optional interface, A-37
- parallel interface, A-31
- serial interface, A-35

Standard raster graphics, R-65, R-74, R-81–R-82, R-99

Strikethrough, C-127, R-53

Style attributes

- font selection and, R-42
- selecting, R-50

Subscript

- canceling, C-131–C-132, R-54
- selecting, C-129–C-130, R-54
- user-defined characters and, R-19

Superscript

- canceling, C-131–C-132, R-54
- selecting, C-129–C-130, R-54
- user-defined characters and, R-19

T

- TIFF compressed mode
 - entering, C-175–C-176
 - exiting, C-222
 - extended raster graphics and, R-83, R-101
 - programming guide to, R-99
- Top margin
 - point size and, R-8, R-60
 - position, R-8, R-60
 - printing area and, R-5
 - setting, C-11–C-12, R-13
- Top-of-form (TOF) position, C-10
- Typeface, C-95–C-96, R-47

U

- Uncompressed mode for raster graphics, R-99
- Underlining
 - scoring, C-127, R-53
 - turning on and off, C-125–C-126
- Unidirectional printing, C-159–C-162, R-55
- Unit, C-50
- User-defined characters
 - deciding where to store, R-29
 - defining, R-17
 - preparing, R-19, R-25
 - recommended size, R-19
 - selecting table, C-77
 - sending to memory, C-84–C-88, C-89–C-90
 - sending to printer, R-31
 - switching to, C-91–C-92, R-36
 - traits, R-22–R-23

V

- Vertical dot density
 - of bit-image graphics, R-67
 - of raster graphics, R-75
- Vertical position, relative in binary mode, C-219
- Vertical print position
 - absolute, C-37–C-38
 - advancing, C-41–C-42
 - graphics printing and, R-56
 - moving, R-60–R-63
 - moving to the next tab, C-45–C-46
 - relative, C-39–C-40
 - text printing and, R-56
- Vertical tab, C-63–C-64

W

- Weight
 - canceling bold, C-112–C-113
 - character, R-51
 - selecting bold, C-110–C-111, R-51
- Width, character
 - commands affecting, R-9
 - proportional spacing and, R-9
 - user-defined characters and, R-19