

Lawrence Berkeley National Laboratory

Recent Work

Title

THE WIDE-BAND DRIVEN RF SYSTEM FOR THE BERKELEY 88-INCH CYCLOTRON

Permalink

<https://escholarship.org/uc/item/1z37j5xb>

Authors

Flood, W.S.

Frazier, P.E.

Publication Date

1972-07-01

Presented at the 6th International Cyclotron
Conference, University of British Columbia,
Vancouver, British Columbia,
July 18-21, 1972

LBL-1294

c1

THE WIDE-BAND DRIVEN RF SYSTEM FOR THE
BERKELEY 88-INCH CYCLOTRON

W. S. Flood and P. E. Frazier

July 1972

Prepared for the U. S. Atomic Energy Commission
under Contract W-7405-ENG-48

For Reference

Not to be taken from this room

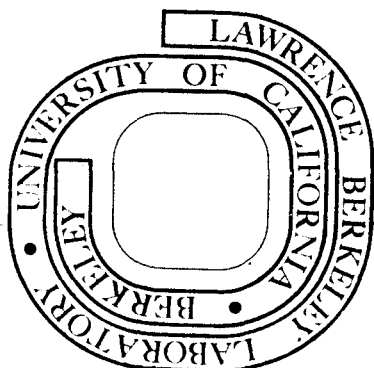

LBL-1294

c1

DISCLAIMER

This document was prepared as an account of work sponsored by the United States Government. While this document is believed to contain correct information, neither the United States Government nor any agency thereof, nor the Regents of the University of California, nor any of their employees, makes any warranty, express or implied, or assumes any legal responsibility for the accuracy, completeness, or usefulness of any information, apparatus, product, or process disclosed, or represents that its use would not infringe privately owned rights. Reference herein to any specific commercial product, process, or service by its trade name, trademark, manufacturer, or otherwise, does not necessarily constitute or imply its endorsement, recommendation, or favoring by the United States Government or any agency thereof, or the Regents of the University of California. The views and opinions of authors expressed herein do not necessarily state or reflect those of the United States Government or any agency thereof or the Regents of the University of California.

THE WIDE-BAND DRIVEN RF SYSTEM FOR THE
BERKELEY 88-INCH CYCLOTRON*

W. S. Flood and P. E. Frazier
Lawrence Berkeley Laboratory
University of California
Berkeley, California 94720

ABSTRACT

The wide-band driven RF system, recently commissioned at the Berkeley 88-Inch Cyclotron, offers a much needed lever on dee voltage stability at no sacrifice in rapid tuning flexibility, hopefully at a substantial reduction in tube replacement costs comparative to the original oscillator RF power source.

INTRODUCTION

Since the adoption of the external beam analysis system at the 88, there has been continued urging toward increased analyzed beam intensity through refinement of the cyclotron beam quality. A substantial improvement in stability of the dee voltage is an important step in meeting this need. The new linear RF amplifier recently put into service provides us with an RF control channel of sufficient gain-bandwidth to enable dee voltage stabilization to the order of .04% or better.

A pragmatic factor which has of course influenced the RF modification is that for the last two years we have been in an economic squeeze between the high and rising replacement cost of 6949 tubes and a severely restricted budget. In view of the comparatively short lifetime given by the 6949 type in self-excited oscillator service at the 88, the discomfort of this pressure was acute, altering the status of the driven system proposal from a desirable improvement to a vital necessity.

Now, the 88 was originally designed with an oscillator specifically to provide fast tuning facility in variable energy experiments. To preserve this valuable convenience, a wide-band, untuned driver chain was incorporated into the new amplifier system.

Here again, considerations of cold cash controlled the configuration and characteristics of the completed construction. But in the case of the driver, things began with a pleasant surprise. We inherited a real windfall in the form of a complete Smith-Gagnon¹ 4 kw, 70 MHz distributed amplifier that had been built and used for RF tests pertaining to the Omnitron study program, and had been more or less abandoned as surplus when that project

*Work performed under the auspices of the U. S. Atomic Energy Commission.

closed.

So for the cost of installation and replacement of a couple of gassy tubes, we had a driver stage that exceeded our requirements by a factor of four in bandwidth (the 88 resonator tunes from 5.5 to 16.5 MHz) and with power capability ample to feed any output stage we might devise.

FINAL POWER AMPLIFIER

For our final power amplifier, we chose the RCA 4648 out of the following considerations:

1) The tube is built on the inside-out, multi-gun structural principle. The grid elements are staked into heavy support frames. Each of the guns is separately recessed into its own slot in the body block. This design approaches, at least, the shield-grid principle of the 6949. We favored this construction over that of conventional communications tubes because it promised better mechanical and thermal stability and some resistance to spark damage.

2) The gain of the tube ($G_m = 1$ mho, $C_{in} = 1,000$ pf) is superior to anything available in gridded tubes in this power range. (The skin power to the 88 resonator, by the way, is about 200 kw max.) Judged by this feature, the tube is in a class by itself for wide-band applications.

3) The price of the tube at the time of our initial purchase was \$5,500.00. It has since been raised to \$7,500.00, which is reasonably competitive for this power range, and only one-fourth the cost of the 6949.

We preferred the 4648 over its smaller (cathode) sister, 4647, because it would meet our maximum power requirements operating in the AB_1 mode. This property simplifies the amplitude regulation loop in that the complication of self-bias is avoided. The cost difference between the two was not enough to influence the choice. The input capacitance of either was low enough to permit an input circuit bandwidth of at least 20 MHz when driven from a 50 ohm characteristic impedance line through a 2:1 step-down matching transformer^{1,3} terminated at the grid in four parallel 50 ohm load resistors. At the high end of the 88 operating range (16.5 MHz) the drive power is 600 W to the terminations plus 600 VAR charging the grid.

The new tetrode was installed in our spare oscillator box (Fig. 1) and fitted with a blocking capacitor patterned after that of the oscillator circuit, using, in fact, the same $BaTiO_3$ capacitors. The output RF conductor area was padded to bring the output capacitance up to match that of the 6949 (Fig. 2). You will notice that the spacing to ground around this RF output conductor appears minimal, but it is actually not less than 1-1/2 inch between carefully smoothed, flat, or well-radiussed surfaces. With the amplifier operating at 20 kv maximum on the plate, the field at the output conductor is about one-fifth the corona point at standard conditions. Incidentally, it has occurred to us that one perennially expensive and troublesome element of the conventional final amplifier, namely the blocker, can be eliminated at the 88, and any other machines where the anode line is capacitively coupled to the dee stem inside the vacuum system. This, provided only that the RF input window to the resonator is rated the same as the P.A. tube output bushing. Removing the blocker has several subtle advantages which are important to the designer, but beyond the scope of this report. We intend to pursue this when time permits.

Coming back to our description, the new "P.A." box was made to interface with the machine interchangeably with the oscillator, omitting, of course, the oscillator grid return line from the resonator.

Changeover time from oscillator to amplifier is about 1-1/2 to 2 hours, and from amplifier to oscillator, 2 to 3 hours. The changeover requires two accelerator technicians, one electronic technician, and four engineering consultants.

As you will see in Figure 3, the input section of the P.A. cabinet is crowded. The required d.c. filament supply² is considerably more bulky than the toroidal single-phase transformer for the 6949. The input matching transformer and its associated cables occupy an appreciable volume. This component is overrated for driving the 4648 in AB₁ service and someday we may rewind it with miniature line³ (e.g., RG 58/U) to recover some space.

There is sufficient if not ample space, however, with direct access to any critical fittings and test points. If proper sequence is followed, assembly and disassembly are not difficult, and if you push hard, the front door will close.

PARASITIC NEUTRALIZATION

We should briefly mention two more P.A. details, if only by way of excusing a year's delay in shipping. These are the screen RF bypass which can be seen in Figure 2, and the fast crowbar, of which we only wish we had a figure for our own use.

The screen bypass is a large disc capacitor assembled as a double-decker Mylar sandwich. The inner conductor is a light copper spinning in the form of a disc extending out from the corona roll, which clamps by fingers to the 4648 screen RF terminal ring. The dielectric is .005 inch Mylar sheet. The top and bottom outer conductors are 3/8 inch copper-plated stainless. To provide sufficient creep-path across the dielectric, the sheets are extended past the outer conductor edges.

A length of #14 Ag plated, stranded copper wire is used as a yielding RF gasket between outer conductors. The sandwich is clamped together by two concentric circles of flush headed bolts. Some of the bolts on the inner circle penetrate the lower plate and tap into the stainless mounting plate for the 4648. Two concentric Cu braid RF gaskets ensure the ground connection to the tube mounting plate and cabinet ground plane. The capacitance is nominally .06 ufd; the voltage test rating is 1,400 V d.c.

This capacitor is an expensive component; it greatly complicates the assembly and tube replacement procedure. Furthermore, we were dubious as to our ability to construct a sandwich capacitor this large and pessimistic about the use of .005 Mylar sheet which we felt was being pushed very hard with respect to RF heating and corona ratings.

Nonetheless, after six months of cutting and trying neutralization and damping schemes around a conventional ring of clay capacitors for the main screen bypass with only mediocre results, we were forced to conclude that with this tube one really has to do a good job of isolation between plate and input circuits.

This is no wonder, for when you stop to think about it, in a cyclotron we are trying to operate a tube with 1 GHz gain-bandwidth product, at full power, into an unloaded cavity. From a transmitter designer's viewpoint, this would be suicide, but that is the way accelerator RF systems are. Well, anyway, the 88 resonator and the output circuitry of the RF system has, below 150 MHz,

several higher order modes presenting 1 K or so shunt resistance to the tube. Some of these tune with the resonator panels, while some do not.

The 4648, with $G_m = 1$ mho, and GBW product, $G_m/C_{in} = 1$ GHz, develops up to 60 db gain on these higher order modes. Now, the internal feedback ratio specified by RCA for the 4648 is somewhat better than -60 db, so that tube itself is stable. Since it is not adaptable to grounded grid operation, the user has no alternative but to extend -60 db separation into the external circuit via a good low inductance, high-frequency screen bypass.

Since our bypass capacitor was built, we have received several helpful suggestions for improving it with respect to corona and RF heating. We were especially impressed by the technique used by Continental Electronics in the RF system for the TRIUMF Cyclotron. They use a Dupont Kapton "H" film dielectric sheet instead of Mylar in their sandwich type RF bypass and coupling capacitors. Electrically it is similar to Mylar, but can withstand much higher temperatures and is available with metallized surfaces. This would eliminate air voids inherent in a clamped assembly such as we have now. A metallized Kapton capacitor might well be expected to last the lifetime of the equipment.

TUBE PROTECTION

With respect to the 6949, one refers to grid "bars" and cathode "strands." The tube is rugged enough to withstand many 10 joule plate-grid sparks without significant damage. The grids in the 4648, however, are fabricated of .003 inch to .005 inch wire; the energy per spark must be limited to the order of a few tenths of a joule. In the case of the 88 resonator, this is the order of the circulating RF energy alone and does not include the d. c. energy stored in the decoupling circuits and HT line. A crowbar divertor is required, and the firing delay should be not more than the order of one RF period.

We have not yet installed a fast plate crowbar in the new RF system, but are developing a u. v. triggered spark gap as quickly as possible. Meanwhile, we are relying on the hard-tube-modulator switch system plus ordinary ball gaps from plate to ground.

In the first 1,000 hours of operation, we have not had much experience with tube sparking due to overvoltage on transients returned to the tube from resonator sparking. We have experienced spark-like anode overcurrent phenomena occurring during tune-up or off-resonance conditions where the plate d. c. voltage is high, RF swing small, and drive normal. This could be due to momentary gas generation from local hot spots on the anode due to beam focussing within the tube. Individual guns have been tested for this effect, and some data is available from RCA⁴.

SYSTEM FEATURES

In closing, we would call your attention to the System Block diagram (Fig. 4) and the summary of system properties in Table I. The control scheme is conventional with respect to RF voltage regulation and automatic cavity tuning.

A feature which is important during turn-on and resonator spark-in periods is the two drive clamp loops, one returning to the control unit modulator (a voltage variable modulator devised from an FET) from the driver chain; the second returning from a wide-band current shunt in the P. A. screen line. It seems that the 88 resonator demands 200 kw at rated dee voltage, at the

extreme high end of the operating band. The skin loss is a strong (square) function of frequency, however. At the low end of the operating range, where most of our current heavy-ion research is now being carried out, the resonator power is only 20 to 30 kw. Consequently, when tuned up at low frequencies, the P.A. is easily overdriven (our driver, remember, is somewhat larger than necessary). Another feature intended to prevent overdrive by the amplitude regulating servo during the resonator charging time, after turn-on, is a slow ramp recycle program.

We have not yet had time to fully exploit the full capability of the wide-band driven RF amplifier as a high-quality servo amplifier for dee voltage control and stabilization. Closed loop disturbances observable in the RF envelope are:

$$\frac{V_{\text{peak to peak}}}{V_1 \text{ peak}} = 10^{-3}$$

as viewed on a d.c. -30 MHz bandwidth, suppressed baseline, scope.

The observable disturbance has two predominant components:

- a) Line frequency derived, due mainly it is supposed, from P.A. screen power supply ripple.
- b) Wide-band noise.

Low frequency drift components are evidently substantially less than these. We will defer improvement in the dee voltage regulator until we decide how to properly measure the accelerating voltage, i.e., it may be much easier to feed back a position signal from the external beam analyzing slits than to build a mechanically stable divider into the cyclotron.

Finally, before interpreting this report as a boast that we have found in the 4648 a direct replacement for the 6949 at one-fourth the cost, we suggest a careful reckoning of costs of 7 kw d.c. filament power supply, 1 KV, 2A, 0.1% regulated, d.c. screen power supply, and fast plate crowbar system. These are all required auxiliaries to the 4648, not needed with the 6949. Further, it will be a long time before the 4648 can accumulate a tube life record approaching that of the 6949 in accelerator RF applications.

REFERENCES

1. B.H. Smith and W. L. Gagnon, "Simplified Distributed Amplifier Design Methods," UCRL-18491, Presented at International Particle Accelerator Conference, February 1969.
2. 4648 RF Power Amplifier Tetrode, Data Sheet Published by RCA Large Power Tube Engineering, Lancaster, Pennsylvania.
3. D. A. Barge and J. Riedel, Distributed Power Amplifier for Princeton-Penn Accelerator, IRE Transactions on Nuclear Science, N.S. 9 (Numbers 2, 19), 1962.
4. J. Tom Cavage, Unpublished Notes on Anode Current Distribution as Function of Anode-Cathode Voltage for 4648 Type Electron Gun, RCA Large Power Tube Engineering, Lancaster, Pennsylvania.

TABLE I

Summary of Properties
Wide-Band Driven RF System
88-Inch Cyclotron
Lawrence Berkeley Laboratory

OPERATING FREQUENCY RANGE, CONTINUOUS	5.5 to 16.5 MHz
OPERATING FREQUENCY STABILITY	10^{-8} per day
OPERATING DEE VOLTAGE	80 peak KV
CW RESONATOR POWER @ 80 KV, 16.5 MHz	200 kw
PLATE INPUT POWER @ 80 KV, 16.5 MHz	300 kw
DRIVER BANDWIDTH	> Full turning range
REQUIRED W. B. DRIVER POWER	1 kw Nominal into 50 ohms
MAIN RESONATOR TUNING MODE	Dee trimmer, $df/f = .05$, under automatic control of efficiency servo around P. A. Full range tuning by manual control of resonator panels.
DEE VOLTAGE STABILITY	$dv/v < 10^{-3}$
DEE VOLTAGE CONTROL LOOP CHARACTERISTICS:	
K_{dc} - 500 HZ RESONATOR POLE	> 1000 2 to 10 KHz Depending on operation frequency
SIGNAL LOOP DELAY	< 0.5 μ sec
APPROXIMATE COST	\$15,000 Material plus 2-1/2 to 3 MY labor (1-1/2 - 2 MY to duplicate)

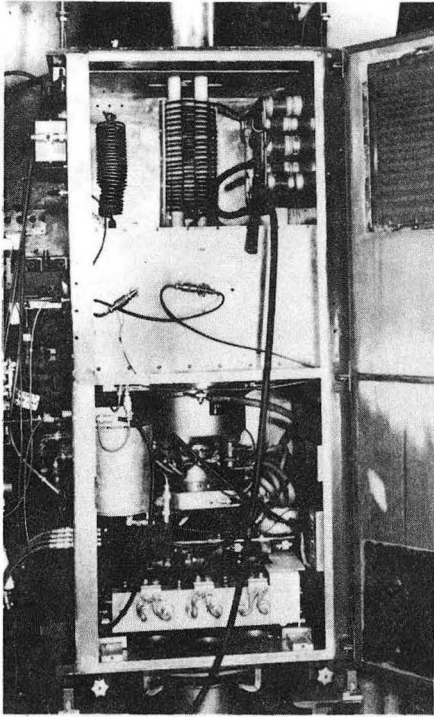

Figure 1. Front View of P.A. Cabinet

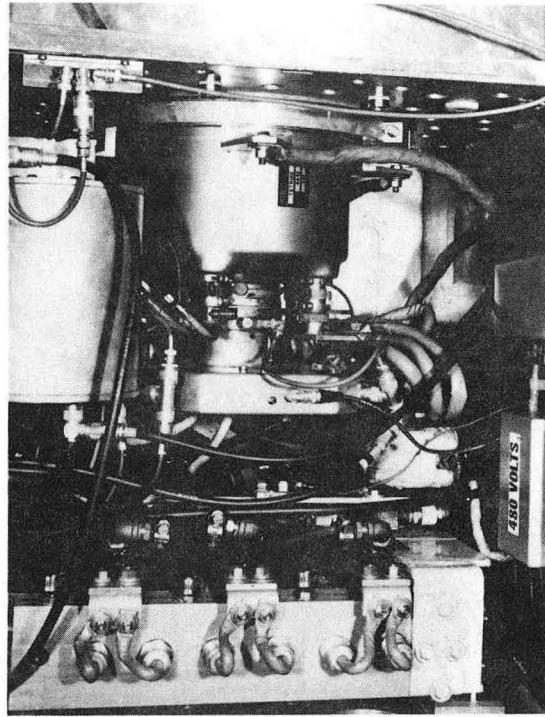

Figure 3. P.A. Cabinet, Input Section.
DC Filament Power Supply at Bottom.

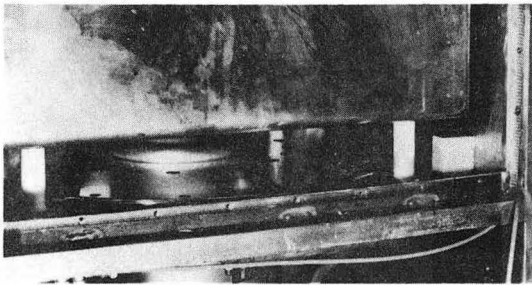
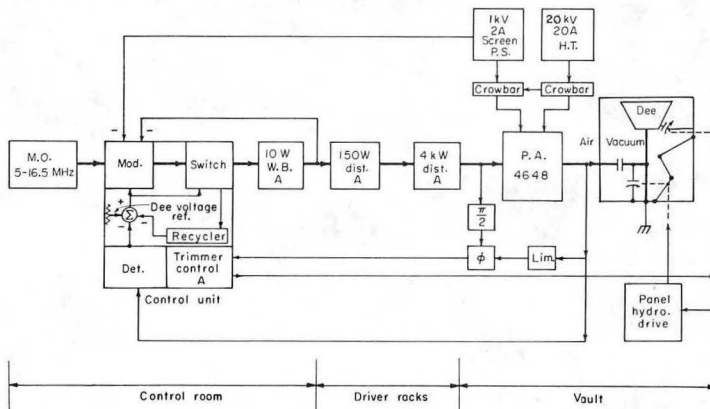

Figure 2.

RF Output Section of P.A. Showing
Screen Bypass Capacitor

88 INCH CYCLOTRON WIDE-BAND DRIVEN RF SYSTEM

Figure 4. Block Diagram



LEGAL NOTICE

This report was prepared as an account of work sponsored by the United States Government. Neither the United States nor the United States Atomic Energy Commission, nor any of their employees, nor any of their contractors, subcontractors, or their employees, makes any warranty, express or implied, or assumes any legal liability or responsibility for the accuracy, completeness or usefulness of any information, apparatus, product or process disclosed, or represents that its use would not infringe privately owned rights.

TECHNICAL INFORMATION DIVISION
LAWRENCE BERKELEY LABORATORY
UNIVERSITY OF CALIFORNIA
BERKELEY, CALIFORNIA 94720