

A Method of Studying the Influence of the Performance of Wireless Computer Networks on Increasing the Accuracy of Distance Measurement

Andriy Dudnik ^{1,2}, Yurii Kravchenko ¹, Nataliia Dakhno ¹, Sergey Mosov ³ and Sergey Grinenko ¹

¹ Taras Shevchenko National University of Kyiv, 60 Volodymyrska Street, Kyiv, 01601, Ukraine

² Interregional Academy of Personnel Management, 2 Frometivska str, Kyiv, 03039, Ukraine

³ Institute of Public Administration and Research in Civil Protection, 21, Vyshhorodska St., Kyiv, 04074, Ukraine

Abstract

Untimely determination of the position of an object that is part of wireless sensor networks leads to the generation of erroneous information in the computerized system for measuring the distance between objects. Such a shortcoming, in turn, can lead to, for example, untimely detection of penetration, ignition source, etc. A particularly favorable environment for this kind of negative consequences is the unfavorable environment in the conditions of the WB. Among the various classes of computer information systems and networks, a special place is occupied by systems and networks whose transport service is based on the use of radio air as a data transmission medium for computerized distance measurement systems (wireless sensor networks). Therefore, in the synthesis of methods for building computerized systems for measuring mechanical quantities, the performance of wireless sensor networks takes an important place. In this paper, a detailed analysis of the types of devices of wireless sensor networks, their main differences, as well as a variant of the topology of their inclusion in the network is considered. It is proposed to improve the principle of operation of the wireless sensor network router by introducing an algorithm based on the redistribution of the bandwidth of the transmission channel. The structural scheme of the device for improving the quality of wireless data transmission in areas of unreliable reception or with insufficient interference resistance has been developed, based on the method "Monitoring the state of the quality of communication".

Keywords ¹

Sensor network, node, anchor, localization, zig-bee, transceiver, radio pulse, time, distance, measurement error.

1. Introduction

One of the ways to solve this problem is to modify the existing classical reference model of open systems interaction (EM OSI/ISO). According to this model, the majority of means of transmission of wireless sensor networks are designed, created and operated. Equally important is the theoretical analysis and search for optimal modeling methods and increasing the productivity of data transmission channels of computerized distance measurement systems. Thus, one of the most problematic areas of wireless sensor networks is untimely transmission of information, as well as errors during transmission. This, in turn, is the cause of the disturbing situation and leads to a high probability of errors when measuring the distance [1-3].

Information Technology and Implementation (IT&I-2023), November 20-21, 2023, Kyiv, Ukraine

EMAIL: a.s.dudnik@gmail.com (A. 1); kr34@ukr.net (A. 2); nataly.dakhno@ukr.net (A. 3); gurman63@ukr.net (A. 4); sergrinenko@gmail.com (A. 5)

ORCID: 0000-0003-1339-7820 (A. 1); 0000-0002-4188-2850 (A. 2); 0000-0003-3892-4543 (A. 3); 0000-0002-3997-2785 (A. 4); 0000-0001-5544-2605 (A5)



© 2023 Copyright for this paper by its authors.
Use permitted under Creative Commons License Attribution 4.0 International (CC BY 4.0).

CEUR Workshop Proceedings (CEUR-WS.org)

Currently, there are various technological solutions for determining the position of objects in space or on the surface of the earth. This is due to the fact that it is impossible to implement one universal method that is suitable for all possible cases. More precisely, it is impossible to create a device whose characteristics would meet the requirements of all (or even most) tasks. The task of positioning arouses great interest among developers and manufacturers of equipment, which may indicate its demand. In addition, most solutions use a radio signal as an information carrier. Therefore, universal devices that allow simultaneous transmission and reception of data, as well as determining one's position in space, will have consumer value. One of the standards regulating the operation of wireless transmission devices with a positioning function is IEEE 802.15.4 [4-5].

This approach to the formation of networks allows adapting sensor networks to solve an extremely wide range of tasks. In particular, one of the main applications of sensor networks is the creation of various monitoring and control systems. It should be expected that in the near future sensor networks will occupy a much wider niche among existing telecommunication technologies that use wireless radio communication. In connection with this, the analysis and search for methods of determining the coordinates of sensor network objects becomes an urgent task [6-9]. The general approach to determining the location of an object is based on measuring the characteristics of a radio signal emitted by a transmitter located on the object and received by stationary receivers with known coordinates. Based on these characteristics, the distance between the transmitter and each of the receivers is estimated [10-12].

Then, taking into account geometric principles, the coordinates of the object are determined. This paper investigates the problem of determining the distance between receivers of chaotic radio pulses. the calculation of the distance is based on the propagation of the signal in the air. The accuracy of the determination between the transceivers is evaluated by the signal transit time, taking into account the interference. In further research, for the possibility of obtaining alternative results, as well as a more detailed analysis of measurement error, laser distance measurement will be included in the sensor network. [13-15].

2. Analysis of literature and problem statement

There are positioning technologies such as GPS, which is discussed in the work of Sichitiu M. [16-17], Galileo, which is discussed in the work of the Federation of American Scientists [18-21], Glonass, which is discussed in the joint work of Spanish scientists on monitoring environment [22-25], the use of Wi-Fi [26] or ultrashort pulses, as described in the corresponding standard of the Institute of Electrical and Electronics Engineers, or GSM cell phone positioning technology, which is the subject of the work of He T. [27-30] and etc.

All these technologies have their advantages and disadvantages. Galileo, GLONASS, GPS, for example, allow you to navigate the earth's surface by carrying a compact device with a set of local maps. These are very useful technologies for moving around in open areas. The accuracy of determining the position of such devices now reaches several meters. However, it can get worse in big cities, in difficult terrain, or simply indoors. In the latter case, the use of satellite positioning is unacceptable. One of the urgent tasks is to determine the location of individual network objects. An indispensable condition for the operation of any monitoring and control systems is the linking of the data collected by the entire system to geographic coordinates for displaying the collected information on the map and further analysis. In addition, such a network (unlike traditional radio networks) with a built-in subsystem for positioning individual objects can be deployed almost anywhere with minimal costs. This can be done, for example, by scattering network objects from an airplane. In addition to linking the data received by the network in the process of work to the map of the area, information about the coordinates of objects will be necessary in the process of functioning of the network itself (building efficient routing algorithms from the point of view of energy consumption, collecting the received data).

The problem of positioning is of great interest to developers and manufacturers of equipment, which may indicate its demand. Moreover, most solutions use a radio signal as an information carrier. Therefore, universal devices that allow simultaneous transmission and reception of data, as well as

determining one's position in space will have consumer value. One of the standards regulating the operation of wireless radio transmitting devices with a positioning function is IEEE 802.15.4.

The general approach to determining the location of an object is based on measuring the characteristics of a radio signal emitted by a transmitter located on the object and received by stationary receivers with known coordinates [6]. Based on these characteristics, the distance between the transmitter and each of the receivers is estimated. Then, taking into account geometric principles, the coordinates of the object are determined.

The following values can be used as signal characteristics:

- signal propagation time from the transmitter to the receiver;
- the difference in indicators of signal propagation time from the transmitter to different receivers;
- signal intensity;
- direction of signal arrival.

The purpose of this study is the development and research of new, as well as the improvement of existing technological solutions to increase the performance of wireless sensor networks that are part of distance measurement systems.

3. Description of the wireless computer network model and the method of increasing its performance

Wireless computer network model. At the base of the ZigBee/802.15.4 technology, there are three classes of devices: FFD-routing devices (Full Function Device - a device with a complete set of functions - *R*), coordinator devices (Coordinators - FFD with additional system resources depending on the complexity of the network - *C*) and RFD end devices (Reduced Function Device - a device with a limited set of functions - *E*). There is only one coordinator in each ZigBee LAN. Its main task is to set parameters and create a network, select the main radio frequency channel, and set a unique network identifier. Therefore, the coordinator is the most complex of these three types of devices, has a large amount of memory and increased power consumption (usually AC power is used). Routers are used to extend the range of the network because they are able to perform the functions of relays between devices located far away one from another. Routers support any ZigBee network topology, can perform coordinator functions and address all network nodes (FFD, RFD). Devices with a limited set of functions do not participate in routing, cannot perform the function of a coordinator, refer only to the coordinator of the local network (FFD device), support "one-to-one" and "star" type topologies, play the role of end nodes of the network. In practice, most of the network nodes are RFD devices, and the use of FFD devices and coordinators is necessary for the formation of communication bridges and the corresponding network topology. As soon as routers and other devices are connected to the network, they receive information about it from the coordinator or any other existing router already involved in the network, and based on this information, they set their operational parameters according to the characteristics of the network. A ZigBee router obtains a table of network addresses, which it distributes among end devices connected to it.

An FFD device uses a reduced addressing tree when making route decisions. Each router that allows shortening must maintain a table containing pairs of the form DN, where D is the destination address and N is the address of the next device on the path to the destination. The combination of routing on the tree-like principle ensures flexibility of operation and gives developers the choice of the optimal price/performance ratio. 1 [1, 2]. Next, the mathematical model for determining the distance between any two neighboring devices of a given network will be considered. When looking at a particular wireless network and a lower speed signal such as 900MHz compared to a 2.4GHz signal, you can get a wavelength function attenuation for each frequency. This will give an indication of signal strength in any band. The general form of the Friis transmission equation (1) is as follows:

$$P_r = P_t G_{Tx} G_{Rx} \frac{\lambda^2}{(4\pi R)^2}, \quad (1)$$

where G_{Tx} and G_{Rx} are the gain of the transmitter and receiver, R is the distance between the transmitter and receiver, and P_r and P_t are the power of the receiver and transmitter, respectively.

Based on this equation, the distance R between the transmitter (Tx) and the receiver (Rx) was obtained (2):

$$R = \sqrt{\frac{P_t G_{Tx} G_{Rx}}{P_r}} \cdot \frac{\lambda}{4\pi} \quad (2)$$

Visually, the model for determining the distance between 2 neighboring devices of a wireless sensor network is presented in Figure 2.

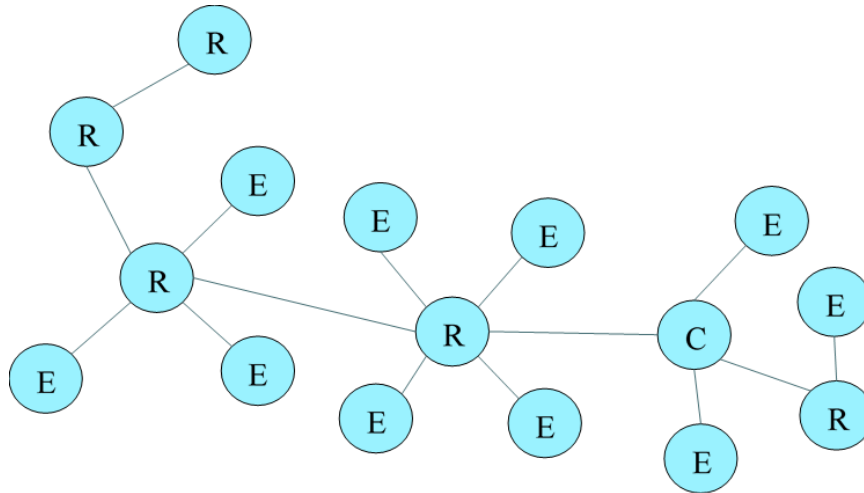

Figure 1: The structure of the sensor network

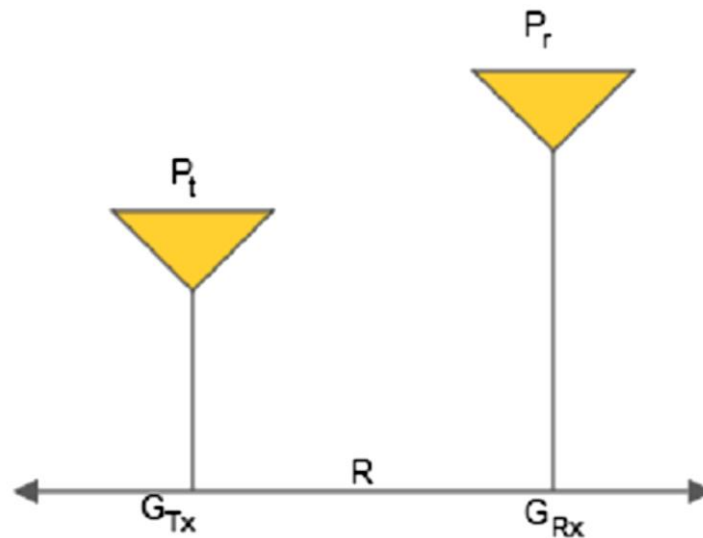

Figure 2. A model for determining the distance between 2 neighboring devices based on the Friis equation

The decibel (dB) form of the Friis equation is defined as (3):

$$P_r = P_t + G_{Tx} + G_{Rx} - 20 \log_{10} \frac{\lambda^2}{(4\pi R)^2} \quad (3)$$

Based on this equation, the distance R will be equal to (4):

$$R = \frac{\sqrt{\lambda}}{4\pi} 10^{\frac{1}{40}(G_{Rx} + G_{Tx} + P_t - P_r)} \quad (4)$$

A 900 MHz signal at 10 m will have a loss of 51.5 dB, and a 2.4 GHz signal at 10 m will have a loss of 60.0 dB. Next, the effect of power and range on signal quality will be shown. Next, the effect

of power and range on signal quality will be shown using a relationship called transmission loss. To do this, you need to use the comparison of the transmission power with the level of sensitivity, measured on a logarithmic scale (dB). It is possible to increase the power level to meet the requirements of a particular band, but in many cases this violates regulatory requirements or affects battery life. Another option is to improve the sensitivity level of the receiver, as implemented in Bluetooth 5 technology of the latest specification. Signal transmission loss (FSPL) is determined by the ratio of transmitter power and receiver sensitivity, as shown below.

$$FSPL = \frac{P_T}{S_x},$$

where P_T - transmitter power, S_x - level of sensitivity.

FSPL is measured on a logarithmic scale in dB; therefore, adding decibels is equivalent to multiplying numerical coefficients, the equation will have the following form:

$$P_r(dB) = P_T(dB) + G_{Tx}(dB) - FSPL(dB).$$

If there is no factor contributing to signal amplification (for example, antenna gain), there are only two ways to improve reception: increase transmission power or decrease loss.

When simulating the maximum range of a particular protocol, Free-Space Path Loss (*FSPL*) will be used. This is the amount of electromagnetic wave signal loss in line of sight in free space (without obstacles). The second factor in *FSPL* is the frequency (f) of the signal, the distance (R) between the transmitter and the receiver, and the speed of light (c). In terms of calculating the FSPLF in decibels, the equation will be:

$$\begin{aligned} FSPL(dB) &= 10 \log \left(\left(\frac{4\pi Rf}{c} \right)^2 \right) = 20 \log_{10} \left(\frac{4\pi Rf}{c} \right) = \\ &= 20 \log_{10}(R) + 20 \log_{10}(f) + 20 \log_{10} \left(\frac{4\pi}{c} \right) = \\ &= 20 \log_{10}(R) + 20 \log_{10}(f) - 147,55. \end{aligned}$$

Based on this equation, the distance will be equal to (5):

$$R = \frac{c}{4\pi f} \cdot 10^{\frac{FSPL(\text{dB})}{20}}. \quad (5)$$

The *FSPL* formula is a simple first-order equation. A better approximation takes into account reflections and wave interference from the earth's surface, such as the flat-earth loss formula. Here h_t is the height of the transmitting antenna, h_r is the height of the receiving antenna. k represents the number of waves in free space and is simplified as shown. Let's convert the equation to use the dB notation:

$$\frac{P_r}{P_t} = L_{\text{losses on a flat surface}} \approx \left(\frac{\lambda}{4\pi r} k \frac{h_t^2 h_r^2}{R^4} \right),$$

Where $k = 2\pi/\lambda$. Based on this equation, the distance R will be equal to (6):

$$R^4 \approx \frac{h_t^2 h_r^2 P_t}{P_r}. \quad (6)$$

A system for increasing the performance of wireless sensor networks. To improve the performance of FFD devices, consider an algorithm for improving the performance of a wireless network based on the redistribution of the bandwidth of the transmission channel [3]. The structure of the capacity distribution system by subchannels is shown in Fig. 3.

Redistribution will take place as follows:

1. The user or group of users with the lowest priority is assigned the number 1, each subsequent priority is assigned a number 1 higher.

2. In the same way, priorities will be assigned to traffic classes.

3. Next, the bandwidth of the subchannel, which will be provided for sending the packet, is calculated according to formula (7):

$$C(\%) = \frac{P_d + P_T}{2} \times 10. \quad (7)$$

where C is the bandwidth in percent, P_d is the device priority, P_T is the traffic priority (this formula is valid only in cases where the sum of the user priority and traffic does not exceed 10).

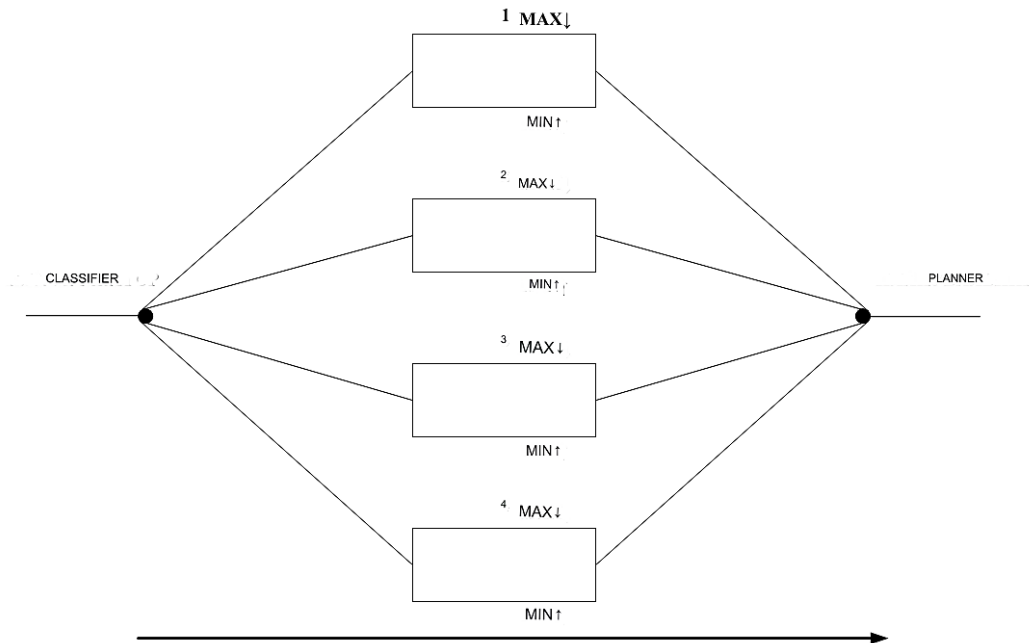

Figure 3. The structure of the transmission channel model of the sensor network using the adapted bandwidth redistribution method

The main condition is that the user with the highest priority is never charged all 100% of bandwidth, and the lowest is never charged with 0%. Based on this method, a structural diagram of the router R (see Fig. 1) with dynamic redistribution of flows was proposed, which implements this model shown in Fig. 3. This scheme is presented in fig. 4.

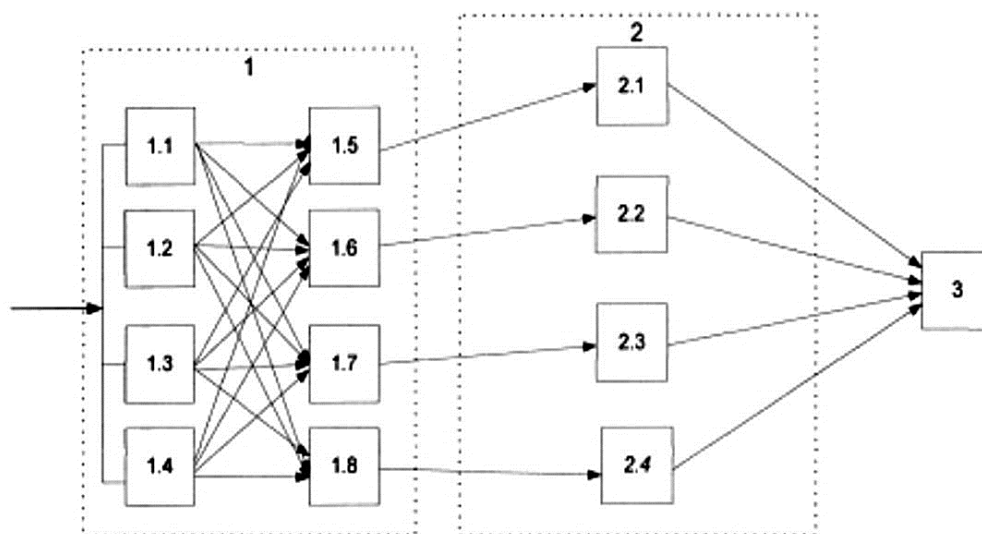

Figure 4. Structural diagram of router R with dynamic redistribution of flows in channels of wireless sensor networks

The task of this model is to improve the conditions for the passage of applications through the serving devices of routers by means of an adapted redistribution of flows to the measuring channel. The task is solved by the fact that a double classifier is introduced into the router with dynamic redistribution of the flow of requests, which contains a classification block that distributes flows according to priority, passing requests through several queues, which distributes requests according to two classes. The introduction of a double classifier into the device favorably distinguishes the proposed router from the prototypes, since in the prototypes only the optimal route is found and the measurement indicators are transmitted along it. In the proposed device, optimal reconfiguration of the parameters of the routing device itself is carried out without switching to another one. The routing device with dynamic request flow redistribution contains a two-stage classifier unit 1, which contains a classifier according to the priority of the device class (E, R, C and one reserve priority) 1.1-1.4 and a classifier according to the priority according to the type of measurement parameters (GPS indicators, data from Internet, laser rangefinder indicators and indicators based on measurements of signal power loss or its arrival time) 1.5-1.8, service device queues 2.1-2.4 and service device (scheduler) 3. The two-stage classification unit 1, which contains a classifier according to the device priority 1.1-1.4 and a classifier according to the priority of the measurement parameters 1.5-1.8, distributes the flow of applications according to the condition of formula (7).

Another task is to enter into the structural diagram of the wireless data transmission device a line that would perform the function of communication between the applications of the physical and network layers of the OSI reference model. That is, it would work on the basis of the signal quality monitoring algorithm. It is for this reason that the signal quality analyzer 5, which is shown in fig. 5.

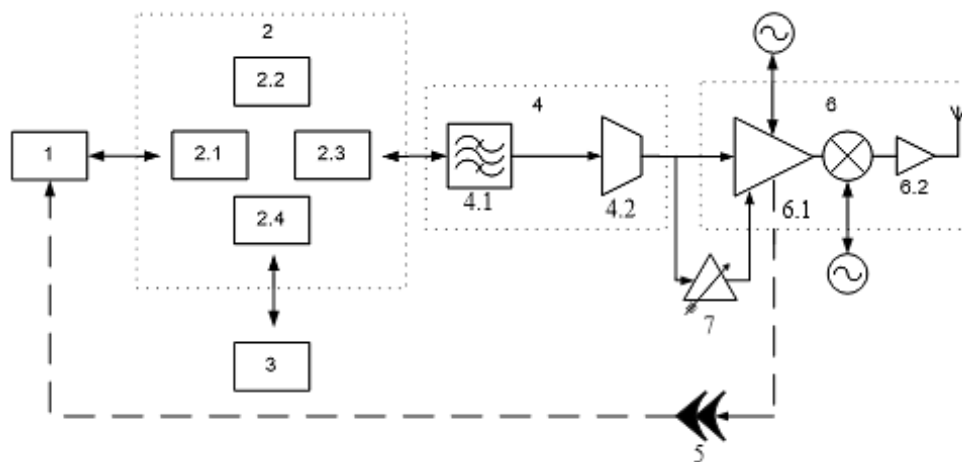

Figure 5. Structural diagram of the device for transmitting data in sensor networks of the IEEE 802.15.4 standard with a system for improving the quality of work in areas of uncertain reception or with insufficient immunity to interference

When building the device, the blocks are divided into modules, according to their belonging to one or another level of the OSI reference model. This device contains a control unit 1, a module of the LLC sub-layer of the OSI model channel layer 2, a host interface unit 2.1, an embedded microcontroller 2.2, a receiver/transmitter application unit 2.3, a bus interface unit 2.4, memory 3, a module of the MAC sub-layer of the OSI channel layer 4, frequency band controller 4.1, radio frequency receiver/transmitter 4.2, signal analyzer 5, OSI physical layer module 6, physical layer interface 6.1, antenna 6.2., automatic frequency adjustment unit 7. The following is a description of the operation of this device. The control unit 1 sends the command to send the packet and the packet itself to the module of the LLC sub-layer of the channel level of the OSI model 2. In the module of the LLC sub-layer of the channel level of the OSI model through the block of the host interface 2.1, after passing the appropriate transformations, with the help of the applications of this module, the packet becomes a frame. After that, the built-in microcontroller 2.2 transmits the frame to the receiver/transmitter application block 2.3 and through the bus interface block 2.4 records the data about the transmission status to the memory 3, where they are stored for a certain time. The

receiver/transmitter application block 2.3 directs the frame to the MAC sub-layer module of the OSI channel layer 4. In the MAC sub-layer module of the OSI channel layer, the frequency band controller 4.1 selects the optimal frequency range for this frame, and directs the frame to the radio frequency receiver/transmitter 4.2. In this module, both the conversion of the frame into electromagnetic oscillations and their modulation according to the content of the frame takes place.

After that, the oscillations are transmitted to the OSI physical layer module 6, and the information about the frequency range selected by block 4.1 is transmitted to the automatic frequency adjustment block 7. Block 6.1 of the OSI physical layer module imposes electromagnetic oscillations on the frequency that is adjusted by block 7. The oscillations are directed to antenna 6.2, which transmits the signal to the radio air. The signal analyzer 5 constantly monitors information about the state of data transmission. It sends appropriate requests to the physical layer 6.1 interface and receives information about the state of data transmission from it. The signal analyzer 5 transmits information about the state of data transmission to the control device 1, after which a decision is made to change the conditions of data transmission as necessary. Decision-making means waiting for improvement in signal quality (according to the rules of the algorithm).

Next, we will describe the convolutional (PBSS) coding method proposed in the previous paragraphs as a technology for improving the quality of data transmission when the signal condition drops. This method is recommended for use in the device of fig. Fig. 3. The idea of convolutional coding is as follows. The sequence of input information bits will be transformed in a convolutional encoder so that each input bit corresponds to more than one output bit. That is, the convolutional encoder adds some redundant information to the original sequence. If, for example, two output bits correspond to each input bit, then we speak of convolutional coding with a rate of $r = 1/2$. If three output bits correspond to every two input bits, then the speed of convolutional coding will be already $2/3$ [6, 7]. Any convolutional encoder is built on the basis of several serially connected memory cells and logical XOR elements. The number of cells determines the number of possible encoder states. If, for example, six cells are used in a convolutional encoder, then information about six previous signal states is stored in the encoder, and taking into account the value of the input bit, we get that such an encoder uses seven bits of the input sequence. Such a convolutional encoder is called a seven-state encoder ($K = 7$). The output bits formed in a convolutional encoder are determined by XOR operations between the values of the input bit and the bits stored in the memory cells, that is, the value of each output bit formed depends not only on the input information bit, but also on several previous ones bits PBSS technology uses a seven-state convolutional encoder ($K = 7$) with a speed of $r = 1/2$. The scheme of such an encoder is shown in Fig. 6.

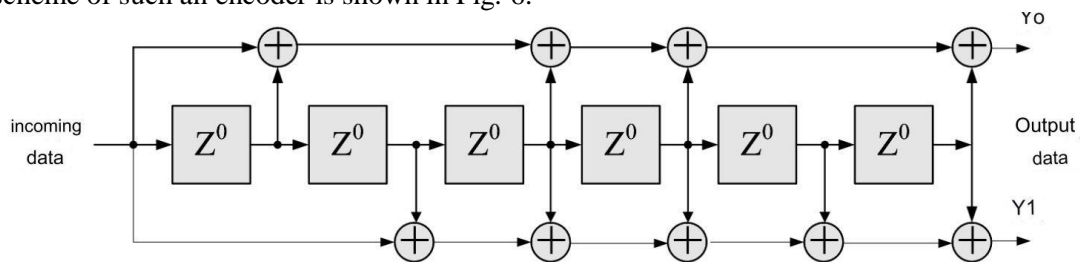

Figure 6. Scheme of a convolutional encoder used in PBSS coding ($K = 7, r = 1/2$)

The main advantage of convolutional encoders is the immunity of the sequence formed by them: even in the event of reception errors, the initial sequence of bits can be restored without error. A Viterbi decoder is used to restore the original sequence of bits on the receiver side.

3. Discussion of the impact of the performance of wireless computer networks on the accuracy of distance measurement

The peculiarities of this device during its operation in a wireless computer network were studied. With the help of a special-purpose wireless network modeling tool, we will calculate the reduction in

data transmission range, depending on mechanical interference, as well as the associated loss of bandwidth. Based on the obtained results, we will construct a graph (Fig. 7).

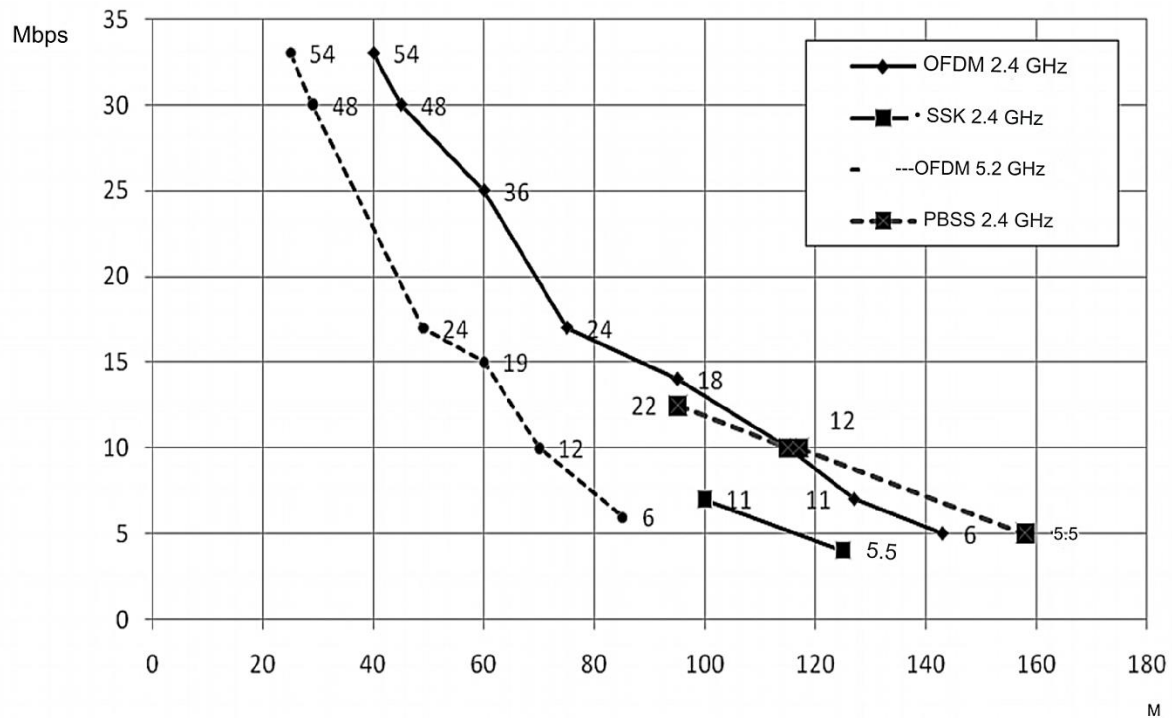

Figure 7. Dependence of the actual transmission speed on the range

Based on this graph, it can be concluded that when switching to the PBSS coding method, 2.4 GHz (highlighted in bold), the data transmission range increases in comparison with OFDM technology, 2.4 GHz, by approximately 15-17 m. For devices, which at the same time will continue to work on the IEEE 802.15.4 standard, the actual speed will reach almost 18 Mbit/s. Based on this, it can be said that the introduction of an additional block into the data transmission device is fully justified, regarding the issue of increasing the data transmission range. Another important characteristic of data transmission is the bit error rate (BER), which also affects the accuracy of transmission of distance measurements. BER shows the number of bit errors received over the communication channel. BER is a dimensionless quantity expressed as a ratio or percentage. for example: If the initial sequence is:

1 0 1 0 1 1 0 1 0 0, and the resulting sequence is:

0 0 1 0 1 0 1 0 1 0 (differences are in bold), then the BER will be 5 errors/10 transmitted bits = 50%.

BER is affected by channel noise, interference, multipath fading, and attenuation. Methods to improve BER include increasing transmit power, improving receiver sensitivity, using less dense/lower order modulation techniques, or adding redundant data. The latter method is commonly referred to as forward error correction (FEC). FEC simply adds additional information to the transmission. In the most basic sense, one could add triple redundancy and a majority choice algorithm; however, this will reduce bandwidth by a factor of 3. Modern FEC methods include interference-tolerant codes and Reed-Solomon error correction codes. BER can be expressed as a function of SNR E_b/N_0 . In Fig. 8 shows different modulation methods and their corresponding BERs for different SNRs.

As the SNR increases, the BER naturally decreases. At this point, you need to understand the following - you can calculate the minimum SNR required to achieve a certain data rate for a distance measurement system. The only way to increase capacity or bandwidth for wireless service is to:

- add more spectrum and channel capacity, which increases the bandwidth linearly;
- add more antennas (MIMO), which linearly improves bandwidth;
- to improve the SNR with the help of improved antennas and receivers, which only improves the level logarithmically;

- the Shannon limit is the final limit of digital transmission;
- exceeding the limits is possible, but the integrity of the data containing the measurement indicators will be lost;
- it is not possible to simply increase the modulation levels without increasing the cost of transmission errors and complexity.

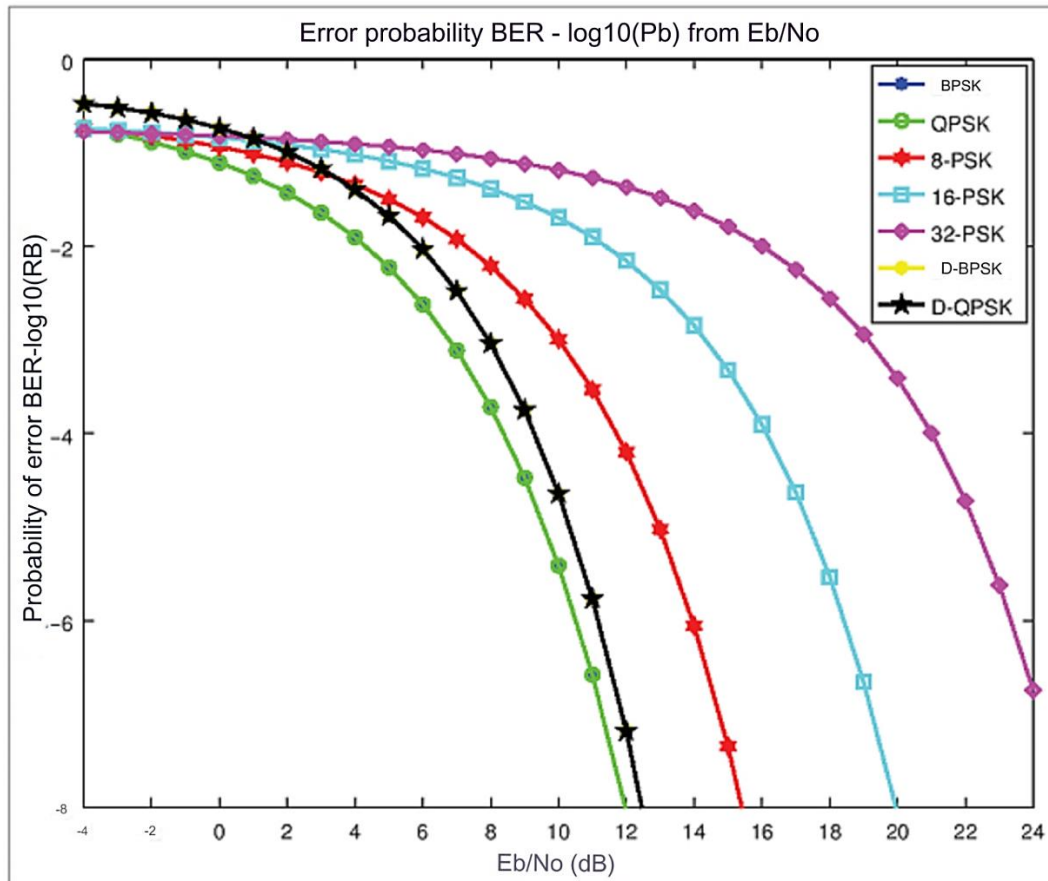

Figure 8. Bit error rate (P_b) versus energy efficiency (E_b/N_o) SNR for different modulation schemes

The distance measurement method that a wireless device uses is Maximum Link Loss (MCL). The MCL is the maximum distance at which there is a complete loss of channel between the transmitter and the receiving antenna, but data service can still be provided. MCL is a very common way of measuring distance or maximum data transmission radius. MCL will include antenna gain, path loss, shadowing and other radio effects. Typically, a 4G LTE system will have an MCL of around 142 dB. It should be understood that if you increase the listening time by each bit, the noise level will decrease. If you reduce the bitrate by 2 times, then the following equality will be true: $(\text{bitrate}/2) = (\text{bit length} \times 2)$. Also, the energy per bit increases by a factor of 2, and the noise energy increases by $\sqrt{2}$. For example, if you reduce Bit_Rate from 1 Mbps to 100 kbps, then Bit_Duration = increases by a factor of 10. The range improves by $\sqrt{10} = 3.162x$.

4. Conclusions

It was determined that untimely determination of the position of an object that is part of wireless sensor networks leads to the formation of a bit error rate (BER) in a wireless network for measuring the distance between objects, which can be up to 50%. Such a shortcoming, in turn, can lead, for example, to untimely detection of penetration, ignition source, etc. A particularly favorable environment for this kind of negative consequences is an unfavorable situation in the conditions of WB.

When modeling the coding methods of wireless sensor networks, it was determined that the highest performance of measurement data transmission is achieved when using the PBSS method, which, compared to the OFDM method, is capable of working at a distance of about 15-17 m longer and collecting a transmission speed of up to 18 Mbit/s.

It is proposed to improve the principle of operation of a wireless sensor network router by introducing an algorithm based on the redistribution of the bandwidth of the transmission channel. A structural diagram of the device has been developed to improve the quality of wireless data transmission in areas of unreliable reception or with insufficient immunity based on the "Communication Quality Status Monitoring" technique.

5. References

- [1] Sharma, G., & Rajesh, A. (2018). Localization in Wireless Sensor Networks Using TLBO. *i-Manager's Journal on Wireless Communication Networks*, 7(3), 32.
- [2] Kannadasan, K., Edla, D. R., Kongara, M. C., & Kuppili, V. (2019). M-Curves path planning model for mobile anchor node and localization of sensor nodes using Dolphin Swarm Algorithm. *Wireless Networks*, 1-15.
- [3] Ali, M. F., & Shah, M. A. (2018, September). Adaptive Transmission Power-Geographical and Energy Aware Routing Algorithm for Wireless Sensor Networks. In 2018 24th International Conference on Automation and Computing (ICAC) (pp. 1-5). IEEE.
- [4] Lin, C. H., Chen, L. H., Wu, H. K., Jin, M. H., Chen, G. H., Gomez, J. L. G., & Chou, C. F. (2019). An indoor positioning algorithm based on fingerprint and mobility prediction in RSS fluctuation-prone WLANs. *IEEE Transactions on Systems, Man, and Cybernetics: Systems*.
- [5] Liu, C., Wang, X., Luo, H., Liu, Y., & Guo, Z. (2019). VA: Virtual Node Assisted Localization Algorithm for Underwater Acoustic Sensor Networks. *IEEE Access*, 7, 86717-86729.
- [6] Bae, H. J., & Choi, L. (2019, May). Large-Scale Indoor Positioning using Geomagnetic Field with Deep Neural Networks. In ICC 2019-2019 IEEE International Conference on Communications (ICC) (pp. 1-6). IEEE.
- [7] Mukherjee, S., Amin, R., & Biswas, G. P. (2019). Design of routing protocol for multi-sink based wireless sensor networks. *Wireless Networks*, 1-17.
- [8] Yang, J., Cai, Y., Tang, D., & Liu, Z. (2019). A Novel Centralized Range-Free Static Node Localization Algorithm with Memetic Algorithm and Lévy Flight. *Sensors*, 19(14), 3242.
- [9] Chaudhary, N., Alves, L. N., & Ghassemloooy, Z. (2019, April). Feasibility Study of Reverse Trilateration Strategy with a Single Tx for VLP. In 2019 2nd West Asian Colloquium on Optical Wireless Communications (WACOWC) (pp. 121-126). IEEE.
- [10] Mohammadzadeh, P., Fard, S. M., Azarnia, G., & Tinati, M. A. (2019, April). Location Estimation of Sensor nodes in 3-d Wireless Sensor Networks Based on Multidimensional Support Vector Regression. In 2019 27th Iranian Conference on Electrical Engineering (ICEE) (pp. 1725-1729). IEEE.
- [11] Gui, L., Zhang, X., Ding, Q., Shu, F., & Wei, A. (2017). Reference anchor selection and global optimized solution for dv-hop localization in wireless sensor networks. *Wireless Personal Communications*, 96(4), 5995-6005.
- [12] Rai, S., & Varma, S. (2017). Localization in wireless sensor networks using rigid graphs: A review. *Wireless Personal Communications*, 96(3), 4467-4484.
- [13] Giri, A., Dutta, S., & Neogy, S. (2020). Fuzzy Logic-Based Range-Free Localization for Wireless Sensor Networks in Agriculture. *Advanced Computing and Systems for Security*, 3-12.
- [14] Aslan, Y. E., Korpeoglu, I., & Ulusoy, Ö. (2012). A framework for use of wireless sensor networks in forest fire detection and monitoring. *Computers, Environment and Urban Systems*, 36(6), 614-625.
- [15] Giri, A., Dutta, S., & Neogy, S. (2020). Fuzzy Logic-Based Range-Free Localization for Wireless Sensor Networks in Agriculture. *Advanced Computing and Systems for Security*, 3-12.

- [16] Liang, J., Yu, X., Liu, X., Mao, C., & Ren, J. (2019). Target Detection, Localization, and Tracking in Wireless Sensor Networks. *Mission-Oriented Sensor Networks and Systems: Art and Science*, 309-361.
- [17] Burinska, Z., Runovski, K., & Schmeisser, H. -. (2006). On the approximation by generalized sampling series in lp - metrics. *Sampling Theory in Signal and Image Processing*, 5(1), 59-87.
- [18] J.F. Luger, *Artificial Intelligence. Strategies and methods for solving complex problems*, 2003.
- [19] A. Teise, P. Gribomon, *A logical approach to artificial intelligence: from classical logic to logical programming*, 1998.
- [20] E. Mizraji, Vector logics: The matrix-vector representation of logical calculus, *Fuzzy Sets and Systems* (1992) 179–185. doi: 10.1016/0165-0114(92)90216-Q.
- [21] Gnatyuk, V. A. (2001). Mechanism of laser damage of transparent semiconductors. *Physica B: Condensed Matter*, 308-310, 935-938. doi:10.1016/S0921-4526(01)00865-1
- [22] R. Yager, D. Filev, Generation of Fuzzy Rules by Mountain Clustering, *Journal of Intelligent & Fuzzy Systems* (1994) 209-219.
- [23] Nitsenko, V., Kotenko, S., Hanzhurenko, I., Mardani, A., Stashkevych, I., & Karakai, M. (2020). Mathematical modeling of multimodal transportation risks doi:10.1007/978-3-030-36056-6_41.
- [24] Alsindi, N., Chaloupka, Z., & Aweya, J. (2014, November). Entropy-based non-line of sight identification for wireless positioning systems. In *2014 Ubiquitous Positioning Indoor Navigation and Location Based Service (UPINLBS)* (pp. 185-194). IEEE.
- [25] Yakut, M., & Erturk, N. B. (2022). An IoT-based approach for optimal relative positioning of solar panel arrays during backtracking. *Computer Standards & Interfaces*, 80, 103568.
- [26] Ashraf, I., Din, S., Hur, S., & Park, Y. (2022). Wi-Fi Positioning Dataset with Multiusers and Multidevices Considering Spatio-Temporal Variations. *CMC-COMPUTERS MATERIALS & CONTINUA*, 70(3), 5213-5232.
- [27] Iatsyshyn, A., Iatsyshyn, A., Kovach, V., Zinovieva, I., Artemchuk, V., Popov, O., . . . Turevych, A. (2020). Application of open and specialized geoinformation systems for computer modelling studying by students and PhD students. Paper presented at the CEUR Workshop Proceedings, , 2732 893-908.
- [28] Hubanova, T., Shchokin, R., Hubanov, O., Antonov, V., Slobodianiuk, P., & Podolyaka, S. (2021). Information technologies in improving crime prevention mechanisms in the border regions of southern Ukraine. *Journal of Information Technology Management*, 13, 75-90. doi:10.22059/JITM.2021.80738
- [29] Phatak, A. A., Wieland, F. G., Vempala, K., Volkmar, F., & Memmert, D. (2021). Artificial Intelligence Based Body Sensor Network Framework—Narrative Review: Proposing an End-to-End Framework using Wearable Sensors, Real-Time Location Systems and Artificial Intelligence/Machine Learning Algorithms for Data Collection, Data Mining and Knowledge Discovery in Sports and Healthcare. *Sports Medicine-Open*, 7(1), 1-15.
- [30] A. Sobchuk, Y. Kravchenko, M. Tyshchenko, P. Gawliczek, O. Afanasieva “Analytical aspects of providing a feature of the functional stability according to the choice of technology for construction of wireless sensor networks”, *IEEE International Conference on Advanced Trends in Information Theory, ATIT`2019, Proceedings*, pp.102–106.
- [31] Y. Kravchenko, O. Afanasyeva, M. Tyshchenko, S. Mykus, “Intellectualisation of Decision Support Systems For Computer Networks: Production-Logical F-Inference”, *International conference Information Technology and Interactions, IT&I-2020, CEUR Workshop Proceedings*, 2021, 2845, pp. 117–126.
- [32] Hnatiienko H. Choice Manipulation in Multicriteria Optimization Problems / Selected Papers of the XIX International Scientific and Practical Conference "Information Technologies and Security" (ITS 2019), pp. 234–245 (2019).