

ATLAS Level-1 Trigger Timing-In Strategies

P. Borrego Amaral*, S. Ask*, N. Ellis*, P. Farthouat*, P. Gällnö*, J. Haller*, A. Krasznahorkay*[†],
T. Maeno*, T. Pauly*, H. Pessoa Lima Junior^{‡§}, I. Resurreccion Arcas*, G. Schuler*,
J. M. de Seixas[‡], R. Spiwox*, R. Torga Teixeira*, T. Wengler*

*CERN, Geneva, Switzerland

[†]University of Debrecen, Hungary

[‡]Federal University of Rio de Janeiro, Brazil

[§]Brazilian Center for Research in Physics, Brazil

Abstract

The ATLAS detector at CERN's LHC will be exposed to proton-proton collisions at a bunch-crossing rate of 40 MHz. In order to reduce the data rate, a three-level trigger system selects potentially interesting events. Its first level is implemented in electronics and firmware, and aims at reducing the output rate to under 100 kHz. The Central Trigger Processor (CTP) combines information from the calorimeter and muon trigger processors, and makes the final Level-1 Accept (L1A) decision, which is transferred to all sub-detector front-ends.

The functioning of the Level-1 Trigger is based on the correct timing of the signals. In this paper we present various strategies for sub-detector timing-in, in particular how to arrive at a decent initial timing setup using test-pulses in stand-alone mode, and in global mode with the CTP. In addition we describe how the beam pick-up detectors are a powerful tool to further refine the timing with bunches in the LHC machine. In this context we describe new developments on a proposal for precision read-out of the ATLAS beam pick-up detectors with commercial oscilloscopes in order to monitor the phase of the clock with respect to the LHC bunches.

I. INTRODUCTION

The ATLAS Level-1 trigger [1] is a system that synchronously processes information from the calorimeter and muon trigger detectors, with a frequency of 40 MHz, corresponding to the frequency of bunch-crossings. The Central Trigger Processor (CTP) [2] forms the Level-1 Accept (L1A) and fans it out to Timing, Trigger and Control (TTC) partitions. In the ATLAS experiment, there are about 40 TTC partitions, each containing a Local Trigger Processor [3], a TTC system [4], and a busy tree which is used to throttle the generation of L1As in case the buffers of the read-out drivers become full.

The data of all sub-detectors are stored during the processing time of the Level-1 trigger, and the mechanism of retrieving them upon a L1A is based on timing only. After the Level-1, each event fragment gets assigned identifiers (L1ID, BCID¹), which allow for asynchronous, identifier-based processing in the subsequent High-Level Trigger. In order to consistently read out data belonging to the same

bunch-crossing it is mandatory to have perfectly timed-in sub-detectors.

Bunches collide in ATLAS roughly every 25 ns. Since collision products travel through the detector at nearly the velocity of light, they travel about 7.5 m before the next collision takes place. For a given time the detector signals in the outer muon chambers are from an earlier bunch-crossing than the signals detected in the inner detectors. Different detector response times and the big spread of cable lengths to and from the electronics cavern worsen the situation. Well-defined procedures for timing-in the trigger and sub-detectors are needed.

This paper describes various timing-in strategies. Emphasis is put on stand-alone sub-detector timing-in using test-pulses, and how the beam pick-up detectors become an essential tool for further timing-in with beam.

II. THE DISTRIBUTION OF TIMING SIGNALS

The CTP received the bunch clock (BC) and the ORBIT signal from the LHC machine via an interface to the TTC [4]. The BC is a 40 MHz clock that is synchronised with the RF frequency at 7 TeV. The ORBIT signal is a 1 μ s long pulse after each turn of the LHC (89 μ s) and is used as bunch counter reset (BCR) to synchronise the BC counters in the sub-detector front-ends. These counters provide the BCID, the bunch-crossing identifier, which identifies each of the 3564 bunches (empty or filled) of the LHC bunch train. The structure of the bunch train, especially the 2.75 μ s long gap² can be used as a reference point: the last bunch-crossing of the long gap can be assigned BCID 0, for instance, such that the first filled bunch has BCID 1.

Together with the L1A the CTP distributes the BC and the ORBIT to all TTC partitions, where the Local Trigger Processor (LTP) serves as the interface between the CTP and the TTC partition. Since the CTP has only 20 outputs, several partitions are daisy-chained via their LTPs. The LTP receives the timing signals from the CTP or an LTP earlier in the daisy chain, and makes the signals available on local outputs, where they can be transferred to the TTC system for encoding and transmission to the sub-detector front-ends. The LTP is in addition an important tool for sub-detector timing-in, because it allows to replace the CTP when running in stand-alone

¹The L1ID is a 32-bit word, which contains the 24-bit event counter value, and the 8-bit event counter reset counter value.

²Abort gap needed to ramp up the extraction kicker magnets in case of a beam dump.

mode. In this mode the timing signals can be generated with an LTP-internal pattern generator or can be fed in through local inputs. Each signal can be independently programmed to be taken from either the CTP link, pattern generator, or local input. When running in stand-alone mode, the first LTP in the daisy chain acts as master and provides all other LTPs with triggers.

III. TYPICAL TIMING TASKS

There are 4 typical timing tasks for each sub-detector:

- **Data Forming:** The data must be sampled optimally with respect to the BC clock (adjust timing of the BC phase).
- **Data Alignment:** The data must be aligned in time at every input stage of processing, compensating for differences in propagation time etc., such that all data belong to the same event (adjust relative arrival times in steps of 25 ns).
- **BC Identification:** The correct BCID has to be assigned to the data such that all event fragments are correctly labelled (adjust timing of bunch-counter reset (BCR) signal in steps of 25 ns).
- **Triggered BC Identification:** The data read out following a L1A signal must belong to the bunch-crossing responsible for the trigger (adjust timing of L1A signal in steps of 25 ns).

While the first two tasks are sub-detector specific, the latter two are more general, global timing adjustments.

IV. ATLAS TIMING-IN STRATEGIES

There are various scenarios at ATLAS where certain timing-in procedures can be applied. The first step will be to time in sub-detectors with *test-pulses*, which can be done stand-alone (local mode), or with the CTP (global mode). With the test-pulses a decent initial timing set-up can be achieved, up to a few bunch-crossings.

When *single beams* become available, the beam pick-up detectors (see section IV-B) will be used to “see” the filled bunches. Since the CTP can be programmed to trigger on specific filled bunches, a filled-bunch trigger can be defined. Global BC identification is now possible. In addition, the filled-bunch trigger can be combined with further signals, such as the scintillation counter hodoscopes [5] in order to trigger on beam-gas collisions.

With *colliding beams* a bunch-crossing trigger can be defined with the beam pick-up detectors, and with combination of the scintillation counter hodoscopes a trigger for minimum-bias events can be obtained. At this stage the phase of the clock can be adjusted to the phase of the incoming sub-detector signals (data forming).

It should be noted that also cosmic-ray muons and beam-halo muons will be used to refine the timing setup. In these scenarios the overall timing is quite different because of the special trajectories of the particles: They do not come from inside the detector. Also, cosmic-ray muons do not come in phase with the BC.

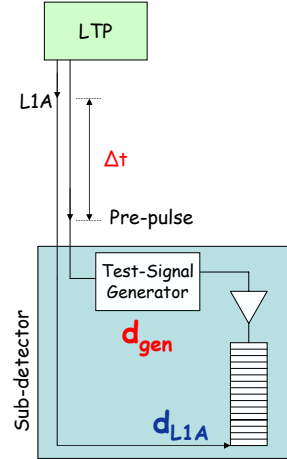

Fig. 1. Timing-in with test-pulses in local mode.

A. Timing-In With Test-Pulses

Many sub-detectors have the capability to generate test signals in order to test their front-end electronics and for calibrations. Fig. 1 illustrates how these test signals can be used for stand-alone timing-in. A pre-pulse from the LTP initiates the generation of the test signal. This should be done synchronously with the ORBIT signal, which is necessary for the next step – running in global mode. A fixed time Δt after the pre-pulse signal the LTP issues a L1A for reading out the data. It is important to notice that the same time Δt will be used later on when running in global mode, and therefore it is the same for all sub-detectors. It will be chosen such that even the slowest sub-detector can cope.

The final goal is to arrive at a decent timing (up to a few bunch-crossings) corresponding to beam-beam collisions. In order to achieve this goal, all the propagation delays need to be estimated upfront: The beam-beam timing should be predicted with a simulation of the time-of-flight, detector response and the specifics of the calibration system. All these delays should be accounted for through a delay in the test signal generator (or alternatively by delaying the pre-pulse signal in the LTP). Also, the expected trigger latency and propagation of the L1A needs to be accounted for, through delays in the L1A generation of the LTP, in addition to the fixed time Δt . After having done all the preparatory work, only a short scan will be necessary to recover the test-pulse data in the Level-1 buffer.

After timing-in the sub-detectors stand-alone, the CTP can be used for timing-in in global mode. The CTP will in this mode generate a L1A for a specific BCID, which is transferred to the sub-detector front-ends through the LTP (see Fig. 2). The pre-pulse signal is still generated within the LTP, with the same time difference relative to the ORBIT. Nothing has changed of the timing in the sub-detectors, so the data will still be captured correctly. Now in global mode, that BC identification is possible. By comparison of the BCIDs of all the event fragments in the read out events, all the necessary BCR offsets for consistent BC identification can be determined. This will give a good initial timing setup for beam-beam collisions, up to a few bunch-crossings, and leaves

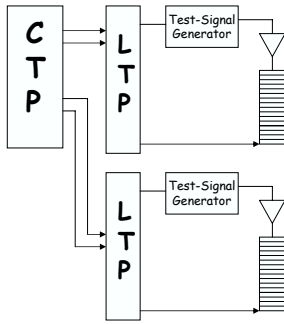

Fig. 2. Timing-in with test-pulses in global mode.

only the global timing to be established later, with beam.

B. Timing-In With Beam

With single beams the global BCR delay can be adjusted such that the BCID corresponds to the correct bunch number in the LHC bunch train. With colliding beams the optimal clock phase for the sub-detector electronics can be adjusted, and the global LIA delay can be set once the Level-1 trigger latency is known. Crucial for the timing-in with beams will be the beam pick-up detectors, with which filled bunches of the LHC machine can be directly “seen”.

V. READ-OUT OF THE BEAM PICK-UP DETECTORS

The beam pick-up detectors (also called BPTX) are beam position monitors as part of the LHC instrumentation, which can be used by the experiments as timing reference with respect to the bunches. For each of the 4 big experiments there is one BPTX per incoming beam, which in the case of ATLAS are located 175 m away on either side of the nominal interaction point. One BPTX station consists of 4 electro-static button electrodes (see Fig. 3 (top)) arranged around the beam as in Fig. 3 (bottom). The read-out of the ATLAS BPTX detectors is currently under study, and a proposal is described in this paper.

Fig. 4 shows how the BPTX signals will be used by ATLAS. The signals from the 4 buttons at each station will be combined to one signal per station and transmitted through 200 m of cable into the underground electronics cavern (USA15). From there they are split to serve two purposes:

- 1) **CTP Input:** The signals are discriminated by preserving the time information at the level of a few nanoseconds, and fed into the CTP as trigger input signals where a *filled-bunch trigger* or a *bunch-crossing trigger* can be defined. Note that the time-of-flight of the bunches to the interaction point and the cable delay from the BPTX to the CTP will be accurately known. With the filled-bunch trigger, gaps in the LHC bunch train can be detected with the help of the bunch-to-bunch scalars of the CTP_MON [6], and a global BC identification becomes possible.
- 2) **Precision Read-Out:** The signals are received by a dedicated read-out system, which also receives clock and orbit signals from the LHC machine through the TTC machine interface [4]. The read-out system will

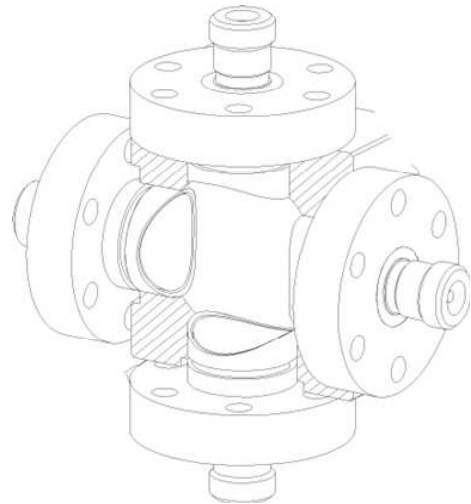

Fig. 3. Top: One electro-static button electrode for the BPTX. Bottom: Arrangement of 4 buttons around the beam.

provide measurements of the phase between the clock and the LHC bunches, for each of the 3564 bunches, with an accuracy much smaller than the intrinsic time resolution of the sub-detectors.³ The aim is to achieve about 20 ps.

The measurements will be used to check the position of each bunch with respect to the clock, and also to monitor the clock phase stability and to detect clock drifts. Such clock drifts could arise from problems in the signal chain, or temperature drifts in the optical fibres used for transmitting the clock. The monitoring frequency can be as low as once per minute.

The high-precision read-out system can also be used to check for satellite bunches in neighbouring “radio-frequency buckets”, which are 2.5 ns apart.

Fig. 5 shows the expected signal of a single button electrode in volts on 50 Ω from a calculation for various numbers of protons, and a nominal bunch length RMS of 250 ps which is expected at 7 TeV. No transmission line is taken into account, but it is expected that about 20 % of the amplitude survives after 200 m of transmission line, with small distortion of the signal shape, which can be calculated from the measured attenuation spectrum. The expected signal amplitude is big

³The time resolution of the Liquid-Argon calorimeters is on the order of 100 ps. Note that the longitudinal bunch length RMS of a nominal LHC bunch will be 250 ps.

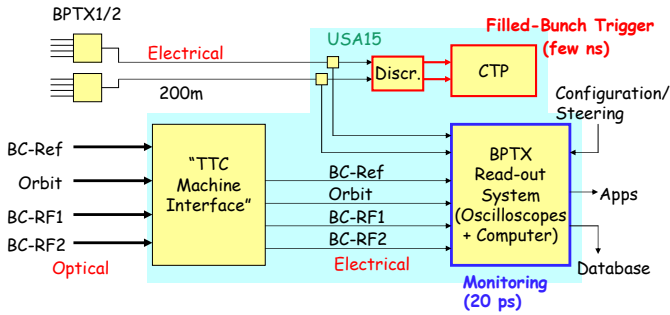

Fig. 4. The beam pick-up detector signals are fed into the CTP for a filled-bunch trigger, and are read out by a dedicated read-out system for monitoring of the clocks from the LHC machine.

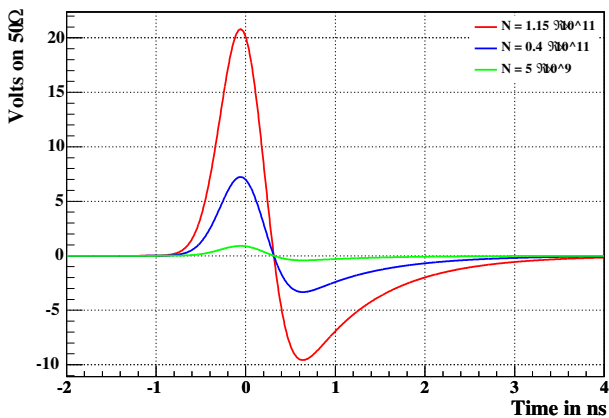

Fig. 5. Signal expectation per button in volts on 50Ω for different numbers of protons.

(20 V for high bunch intensity, 1 V for pilot bunch intensity) and background (noise, reflections, etc.) is expected to be small.

Without taking into account the transmission line, the calculation yields:

$$u_R(t) = - \int_{-\infty}^t dt' \frac{Z_T N e}{\sqrt{2\pi}\sigma} \cdot \frac{t'}{\sigma^2} e^{-\frac{t'^2}{2\sigma^2}} e^{-\frac{t+t'}{RC}} \quad (1)$$

where $Z_R = 1.04 \Omega$ is the transfer impedance, $R = 50 \Omega$ and $C = 16 \text{ pF}$. There are 3 free parameters:

- t_0 : Time of closest approach of the bunch to the electrode.
- N : Number of protons in the bunch.
- σ : Bunch length RMS (Gaussian σ)

This description can be used as a fit function to the measured signal in order to extract the free parameters t_0 , N , and σ .

VI. PRECISION READ-OUT OF THE ATLAS BPTX

For the precision read-out we propose to use commercial oscilloscopes, which have the advantage of relatively low cost (several 10 kCHF), no need to develop hardware and low-level software, and that there will be guaranteed support from the vendor. In addition, the signal is fully visible, i.e. there is no signal discrimination before the read-out, which is necessary

for debugging. As most oscilloscopes usually have a maximum of 4 channels, 2 oscilloscopes will be required for the 6 signals seen in Fig. 4 (BPTX beam 1, BPTX beam 2, BC-Ref, BC-RF1, BC-RF2, ORBIT).

We have performed a system test with a Tektronix TDS 3054B [7], in order to show that this proposal is feasible, for an estimation of the possible resolutions, and to identify strengths and weaknesses of the read-out system. The TDS 3054B has 4 channels, and offers a 5 GS/s real-time sampling rate when using 1 channel, which corresponds to a voltage measurement every 200 ps. It has a memory deep enough to accommodate 10000 of such measurements, corresponding to a time interval of $2 \mu\text{s}$. The maximum voltage on 50Ω is 5 V (RMS) with peaks smaller than $\pm 30 \text{ V}$, and the vertical resolution is 8 bits, i.e. 0.3 % relative to the selected maximum vertical scale.

As clock the 40 MHz clock of a TTCvx module was taken, and as BPTX test signal the shaped output from an LTP pattern generator was used. The pattern generator allowed to imitate the LHC pattern of filled bunches, including the abort gap. The oscilloscope data acquisition was triggered by the BPTX signal itself, using the trigger hold-off to find the abort gap⁴. The so acquired clock and the BPTX test signal was read out via the built-in ethernet port using the HTTP1.1 protocol (the oscilloscope can also be configured this way). Subsequent data analysis was done using ROOT [8] and MINUIT [9]. Fig. 6 shows part of the read-out signals: The BPTX test signal is seen as the top curve, where the vertical amplitude is arbitrary, and the clock signal is the lower curve. Each point corresponds to a single voltage measurement, and two consecutive points are 200 ps apart. For each signal a simple discrimination is performed: at -400 mV for the clock signal, and at the first zero-crossing after a $+200 \text{ V}$ threshold for the BPTX test signal. In an appropriate region a polynomial fit is used to determine the exact time position of the discrimination. The result of the fit is overlaid by a thin line, and the fitted time position indicated by a vertical arrow.

For an estimation of the resolution of the time discrimination of the clock signal, the difference between two consecutive clock ticks is calculated for every second clock tick, and shown in Fig. 7. A Gaussian with the correct mean value of 25 ns is obtained, with a width of 20 ps, corresponding to the resolution of a single measurement of the phase difference between two clock ticks. Because the steepness of the expected BPTX signal is similar to the steepness of the clock signal, this resolution corresponds also to the resolution of the measurement of the phase between the clock and the BPTX signal. This proves that 20 ps is indeed possible. The resolution of a single time measurement on the other hand is $20 \text{ ps}/\sqrt{2} = 14 \text{ ps}$.

A full fit to the BPTX signal will not only increase the resolution of the time measurement, but will also yield estimates on the bunch intensity and length. A toy simulation was used to estimate the resolution of this method. 1000 samples were generated, using the parameters of the TDS 3054B

⁴The trigger hold-off time needs to be set to $88.92 \mu\text{s} - x$, with $x < 2.75 \mu\text{s}$.

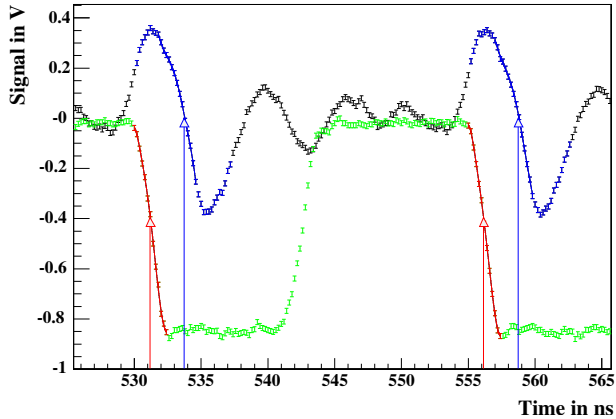

Fig. 6. Detailed view of the signals read in from the scope via ethernet. Each point corresponds to a voltage measurement on 50Ω every 200 ps. Displayed is the BPTX test signal, and the BC. Polynomial fits to the signals are performed in dedicated regions, and the result of the obtained time measurement displayed as vertical arrows.

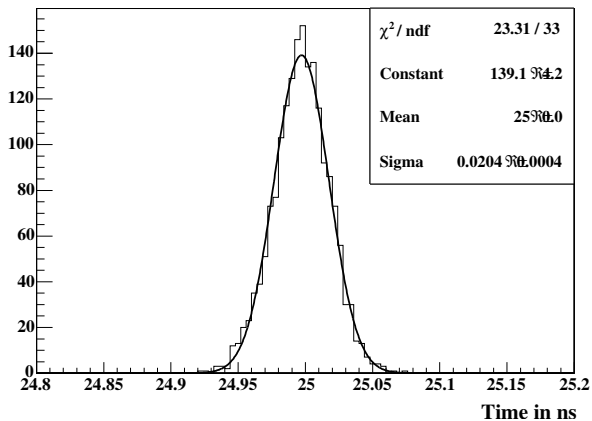

Fig. 7. Histogram of the difference between consecutive clock time measurements. No clock tick is double counted. The resolution on the clock difference measurement is 20 ps.

(vertical resolution 0.2 V) and the nominal LHC bunches, and subsequently fit with the full signal description (Eq. 1). The resulting fit parameters follow Gaussian distributions:

$$t_0 = (0 \pm 2.6) \text{ ps} \quad (2)$$

$$\sigma = (252 \pm 3) \text{ ps} \quad (3)$$

$$N = (1.150 \pm 0.015) \times 10^{11} \quad (4)$$

where t_0 is uncorrelated, and with a strong correlation between σ and N of 0.68. This shows that the time resolution of a full fit to the BPTX signal is expected to be well below 10 ps, and even σ and N can be determined at the percent level.

With the system tests described here it becomes clear that the precision read-out requirements for the ATLAS beam pick-ups can be fulfilled with 2 modern commercial sampling oscilloscopes with:

- 4 channels each
- Sampling rate $\geq 5 \text{ GS/s}$

- Memory deep enough to accommodate $89 \mu\text{s}$
- Communication via ethernet

VII. CONCLUSIONS

We have presented in this paper strategies for timing in the sub-detectors, in particular how to achieve a decent initial timing up to a few bunch-crossings by using test-pulses, in stand-alone mode and in global mode. For timing-in with beam the beam pick-up detectors are very powerful: They can be used as input to the CTP to define filled-bunch and bunch-crossing triggers, which allow global BC identification. In addition they allow to measure and monitor the phase between the LHC clock and each LHC bunch to a precision of 20 ps.

ACKNOWLEDGEMENTS

We would like to thank our colleagues from the calorimeter trigger, barrel muon trigger, end-cap muon trigger, data acquisition and AB/BDI groups for their friendly and competent collaboration without which the work presented in this article would not have been possible.

REFERENCES

- [1] The ATLAS Collaboration, “*First-level Trigger Technical Design Report*,” CERN/LHCC/98-14, June 1998.
- [2] R. Spiwoks *et al.*, “*The ATLAS Level-1 Central Trigger Processor (CTP)*,” these proceedings.
- [3] P. Gällnö, “*The ATLAS Local Trigger Processor (LTP)*,” <http://edms.cern.ch/document/374560>
- [4] S. Baron *et al.*, “*TTC challenges and upgrade for the LHC*,” these proceedings.
- [5] M. Nessi, “*Minimum bias scintillator project status*,” <http://edms.cern.ch/document/509337/>.
- [6] H. Lima, “*User manual for the CTP Monitoring Module (CTP_MON)*,” <https://edms.cern.ch/document/603922/1>.
- [7] <http://www.tektronix.com/>
- [8] R. Brun *et al.*, “*ROOT*,” <http://root.cern.ch/>.
- [9] F. James and M. Roos, *Comput. Phys. Commun.* **10** (1975) 343.