

Mr. Simon VAN DER MEER/PS E-12

ACOL CLOSED ORBIT CHANGE ASSOCIATED WITH TRIM CURRENT VARIATIONS

L. Rinolfi

1. Introduction

In the ACOL machine, all dipoles are connected in series. However one trim supply connected on wide dipoles allows a closed orbit change in straight sections where the dispersion is zero.

The correction coefficients on main power supply and trim power supply are calculated. They allow a closed orbit change by a given amount and keep the orbit length constant.

2. Principle

Fig. 1

The figure 1 shows the connections of ACOL dipoles. ΔI_T is the trim current variation and ΔI_B is the main current variation. They are 8 BHW, 15 BHN and 1 BHS. All have the same deflection angle.

Changes at position(s) are associated with changes in BHW magnetic field by the relation ¹

$$\Delta q(s) = \frac{\sqrt{\beta_H(s)}}{2 \sin \pi Q_H} \frac{\phi_0}{I_0} (\Delta I_T) \sum_{n=1}^8 \left\{ \sqrt{\beta_{e_n}} \cos \varphi_n - \frac{l_{BHW}}{2\sqrt{\beta_{e_n}}} [\alpha_{e_n} \cos \varphi_n + \sin \varphi_n] \right\} \quad (1)$$

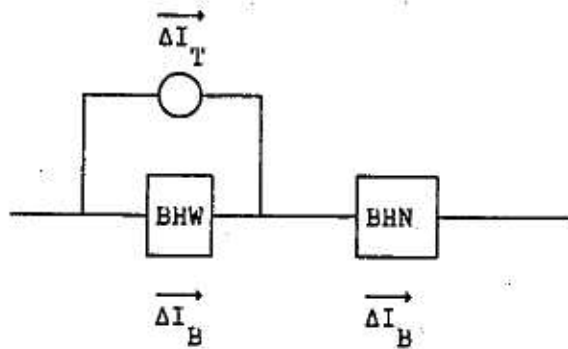
where $\varphi_n = -\pi Q_H + \mu_{e_n}(s) - \mu(s)$ and the index "e" means at the entrance of the element.

The main current has no effect on closed orbit modulation.

To keep the orbit length constant, the relation between ΔI_T and ΔI_B should be

$$\Delta I_T + 3\Delta I_B = 0 \quad (2)$$

3. Correction coefficients

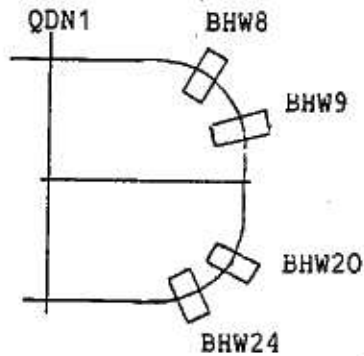

Fig. 2

The figure 2 shows the 4 BHW dipoles for one superperiod.

The trim correction current is given by

$$\Delta I_T = CT \Delta q \quad (3)$$

The main correction current is given by

$$\Delta I_B = CB \Delta q \quad (4)$$

where CT is the inverse coefficient of ΔI_T in formulae (1) and $CB = -\frac{1}{3} CT$.

4. Numerical results

The correction is calculated at $s = 0$, i.e. middle of QDN1. The calculation is made for one superperiod. However, it is possible to obtain these coefficients at different azimuths.

With Δq expressed in mm : $CT = -1,36$ A/mm
 $CB = +0,45$ A/mm.

The values assume a linear relation between the magnetic field and the current. The nominal current is 2280 A.

For AA machine, these coefficients are :

$$CT = -0,18 \text{ and} \\ CB = +0,102.$$

5. Dipole characteristics²

	BHN and BHW	BHS
l (m)	1.963	1.986
ψ_0 (rad)	0.2458	0.2458
I_0 (A)	2280	2280

References

1. B. Autin, Lattice perturbations, CERN/PS 84-22 (AA), 1984.
2. J. Vlogaert, ACOL dipoles, CERN/PS 87-5 (EMA), 1987.

Distribution

ACOL/1 List

/ed