

**The contribution of the lead plate thickness
non-homogeneities to the Barrel Electromagnetic
constant term.**

B. Canton, D. Imbault, P. Repain, P. Schwemling
LPNHE - Universités Paris-VI,VII and IN2P3-CNRS.

B. Mansoulie, P. Perrin, J. De Troff
CEA, Centre d'études de Saclay, Gif-sur-Yvette, France

L. Baisin, P. Lançon, A. Sigrist, V. Vuillemin
European Laboratory for Particle Physics (CERN), Geneva, Switzerland

1 Introduction

It is well known [1] that the physics channels $H \rightarrow \gamma\gamma$ and $H \rightarrow ZZ \rightarrow 4e$ are the most demanding in term of resolution of the electromagnetic calorimeter system. Furthermore, none of the sampling term, the pile-up term, the electronic noise and the constant term can be neglected when trying to optimize the physics discovery potential of the calorimeter in the corresponding energy domain, which extends typically from 10 to 100 GeV. Physics simulations have shown [1, 2] that a sampling term of $10\%/\sqrt{E}$ or less is adequate, provided the constant term is less than 1%.

One of the contributions to the constant term is the non-homogeneity in the thickness of the absorber plates : If the thickness of the plates used to build the lead converter increases, the collected energy diminishes, since the sampling fraction diminishes. It has been found on prototypes that this effect contributes 0.3% to the total constant term, which is 0.7%. In the following, we will concentrate on the contribution to the constant term arising from this non-homogeneity, we will discuss our strategy to keep this contribution under control, and to try to bring it under 0.2%.

2 Experimental results

One very important ingredient needed to discuss the contribution of the non-homogeneity of plate thicknesses to the constant term is to know precisely by which amount a variation of plate thickness changes locally the response of the calorimeter. This point has been studied by the RD-3 collaboration, with its 1992 2m prototype [3], as shown in figure 1. From this study one can easily deduce that an increase of 1% in lead thickness decreases the response by 0.5% . To state it a bit differently, a change of 10 μm in lead thickness, for 1.2 mm plates, changes the response of the calorimeter by 0.4% .

3 Goals and requirements on lead quality

The dimensions of the plates are 700×3200 mm, in two pieces of different thickness.

To control as much as possible the effect of non-homogeneity of absorber thickness, we have set the following goals on lead quality :

- We require the r.m.s. of the thickness measurements within each plate to be less than 10 μm . The measurements will be done by a machine based on an ultrasonic transducer. This machine is presently under

final design. Many tests have already been achieved, whose results will be presented in the next sections.

- These plates should be homogeneous enough that the dispersion of the mean thicknesses is less than $5 \mu\text{m}$. In case this would turn out not to be reachable, the plates will be paired in such a way that the dispersion of the mean of each pair is as small as possible, and in any case, no more than $5 \mu\text{m}$. In section 5, we will show how a pairing procedure can improve the constant term.

The goal that is behind these technical requirements is to bring the contribution to the constant term of the lead thickness non-homogeneity beyond 0.2% .

4 Measurement results

In this section, we show some test measurement results that have been done on a batch of lead plates that will be used to build a model of the electromagnetic barrel modules. This work is largely documented in [4], and we will only summarize here the results.

We have done our measurements using ultrasonic control. This metrology technique, that is very widely used in the industry, consists in sending an ultrasound signal through the object whose thickness is to be measured and evaluate the time between two successive echoes. We have chosen this method for several reasons :

- It is easy to implement as part of a complete measuring machine, since the apparatus is very small and very versatile : the sensor can be used in any position, there is no need to position it precisely with respect to the plate to measure.
- One needs only access to one face of the plate.
- It is possible to study local deformations of the plates. This is impossible with other methods like weighing the plates.

4.1 European lead plates

These plates are the ones that have been used for the model. They have been provided by the GROC ¹ company, selling plates fabricated by ROHR company. The set we measured consists in a batch of nominal thickness

¹GROC, ZI rue de Belloy, 95560 Montsault

1.2 mm, and in a second batch of nominal thickness 1.8 mm. Within each batch, there were two types of plate shapes : some were trapezoidal, the others were rectangular (nearly squares). The measurements have been done by hand. This implies that the positioning of the sensor could not be done with an accuracy greater than a few mm, but this is not a problem since we were interested mainly in seeing thickness variations on a scale of the order of a tenth of centimeters. An example of a survey of a plate with a 2.0 cm step between two adjacent points is shown in figure 2. It should be noted that this plate is one of the worst plates we have found during the measurements. However, a 2.0 cm step for all plates would have lead to a prohibitive measurement time. One can see that the structures are of a typical size of 20 to 30 cm, so we decided to use a step of 15 cm, which is enough to resolve these structures. Of course, with an automated measuring machine, it will be painless to go to a smaller step.

4.1.1 Intrinsic resolution of the apparatus

The intrinsic resolution of the apparatus has been evaluated by three different methods :

- Regular measurements of the same points on a reference plate. These reference measurements were taken once per plate measured. (fig. 3). The total measurement time was about 30 days, and there was no observable drift of the reference measurements over this time.
- Redundant measurements of some points on all the plates. (fig. 4)
- Comparison between a palmer and the ultrasonic sensor for one point on each plate. (fig. 5)

The three methods were found to yield consistent numbers for the resolution, and we concluded that the intrinsic resolution of the apparatus was 6 microns, for the plate thicknesses under consideration, and for manual measurements.

4.1.2 Calibration error

The ultrasonic sensor does not directly measure a thickness ; it measures in fact the time the sound waves need to propagate through the plate. This time is converted into a distance by multiplying by the sound velocity. This velocity is not easy to be known precisely. An estimate of it can be deduced from the comparison between the palmer measurements and the measurements taken by the ultrasonic sensor assuming an arbitrary reference speed. This is shown figure 6 : The ratio between the palmer measurement and the

Plate type	average (mm)	r.m.s. (μm)
1.2 mm trapezes	1.176	6.1
1.2 mm squares	1.172	4.4
1.8 mm trapezes	1.811	9.6
1.8 mm squares	1.818	11.1

Table 1: Average and r.m.s. of the distributions of the plate mean thickness.

ultrasound measurement for the same point gives an estimate of the coefficient by which one should multiply the arbitrary velocity of sound to get the actual velocity of sound, in other words, of the calibration constant. Conservatively, since the statistics we had did not enable us to have a clear view of the distribution of the individual measurements of the calibration constant, we estimate conservatively the error on this constant by the r.m.s. of its distribution. This leads to a $\simeq 5 \mu\text{m}$ error, for all types of plates.

4.1.3 Distributions of the measurements

In figure 7 and 8, we give the distributions of the average thickness and of the r.m.s. for all the types of plates. The information on the average thickness is summarized in table1

Particularly bad plates show up as outliers in the distributions of the (with bumps or “holes”) r.m.s of thickness measurements within one plate .

4.1.4 Long-range variations of thickness

Since the plates were all coming from the same rollers and were all rolled in the same order when they were shipped to us, it was possible to study long-range thickness variations. We did that by averaging the measurements taken on slices of 15 cm, so we could see all the structures bigger than 30 cm, up to 30 m. We discovered in the plates we were measuring several long-range thickness variations. The first kind of variation is periodic, with a period of about 150 cm, which is not related to the size of the plates. (Figure 10). The plate whose map is shown in figure 2 is on the right end of figure 10 : One clearly sees that this plate is very bad, as said before.

The fact that there is no simple relation between the size of the plates and the periodicity observed leads us to think that this periodicity may be due to defects on the rollers. Superimposed to this variation, one can see very big variations on a very short distance scale. These variations may be due to temporary stops of the rollers, or changes in the rolling parameters.

Both kind of variations should be reported to the manufacturer, so they can be avoided later. This will be especially important when going to the real detector, and contacts will be taken before the construction with the manufacturer, to try to understand more precisely the variations.

4.2 American lead plates

We present here, as a comparison, a measurement that has been done on a plate manufactured by an the american company Doe Run². These measurements show that in the transverse direction, the tolerance is within ± 0.28 mm, whereas in the longitudinal direction the thickness only varies by $6 \mu\text{m}$. From figure 9, one sees that most of the transverse deviation occurs in the last 4 inches on either side. This is due to the so-called “crowning” effect of the rollers. If one removes these total 8 inches of crowned plate, one would get a plate whose deviations would be of $\simeq 2 \mu\text{m}$ (in r.m.s.) for a width of 15 inches, i.e. $\simeq 40$ cm.

5 Simulation of the pairing

We have studied how one could pair the plates, so as to equalize the thickness non-homogeneities. To do this study, we have written a simulation program, that computes for each event the response of the calorimeter, given the distribution of plate average thicknesses, and of thickness within one plate. The thickness variations within one plate are supposed to occur on a length scale of the same order of magnitude as the shower size. The other ingredients of the model are :

- The shower axis is parallel to a set of parallel plates.
- We assume the transverse shower development to be given by the widely used function :

$$f(r) = \frac{2rR^2}{(r^2 + R^2)^2}$$

where r is the distance to the shower axis, and R a parameter we have adjusted so that 99% of the shower energy is deposited on 9 plates (corresponding to 3 cells).

- The local response of the calorimeter is decreased by 0.4% for an increase of $10 \mu\text{m}$ in plate thickness.
- The longitudinal shower development is supposed to be the same at all the energies.

²Doe Run Company, 11885 Lackland Road, St-Louis (MO)

Pairing	dispers. within one plate	dispers. among all plates	Const. term
no	10 μ	5 μ	0.20% \pm 0.04
no	10 μ	10 μ	0.28% \pm 0.04
yes	10 μ	10 μ	0.17% \pm 0.04

Table 2: Constant term for different plate distributions with and without pairing. The errors have been determined by rerunning the simulation with different random seeds.

For several energies, we generate typically 1000 to 10000 events, evaluate the response of the calorimeter for each event, and then compute the resolution as a function of energy. A simple fit gives then the constant term.

With this simple model, we have studied the effect of non-homogeneities on the constant term, for a calorimeter of 1000 plates, for several distributions of the mean value of the plate thickness r.m.s. and of the r.m.s. within each plate. All the distributions are supposed to be gaussian.

The results are showed in table 2. The pairing has been done by looking for each plate, which plate should be associated to it to give a pair as close as possible to the mean thickness value. One clearly sees that the pairing allows to recover the degradation caused by the quality diminution of the plates. However, the simulations presented here has been done assuming that a given plate can be paired with any other to be chosen among the set of plates corresponding to the whole calorimeter. This is clearly unrealistic, because it means that all the plates have to be measured before any absorber can be manufactured, and it involves a lot of manipulations. Studies are underway to overcome this difficulty. One possibility is to store the plates in batches, as they come from the manufacturer. Of course, only the plate on top of the batch can be taken out easily. The idea to make a compromise between perfect pairing and no pairing at all is to choose the pairs only among the ones that can be taken without special manipulations, i.e. the ones that are on top of batches. For a reasonable number of batches (10? 50?), given a plate, there is a good probability to find an other one that matches nearly as good as in the “ideal” case. Simulations are underway to optimize the main parameter of the procedure, the batch size.

6 Conclusion

We have presented a study on the influence of the non-homogeneities of the lead converters to the ATLAS electromagnetic calorimeter constant term. We have done an analysis of test measurements, that give us information

about the quality the lead manufacturers can and cannot achieve. From this information, we have tried to discuss how we will process to reach the expected value of the constant term, and we feel that the goal can be reached.

One of our aim is to not only measure each plate to simply check the quality and use them “as is”, we want to try to get the best lead quality as possible. To reach this goal, we will set up a procedure that will have to be followed very precisely, by us and by the industrial partners.

References

- [1] ATLAS Technical Proposal, CERN/LHCC/94-43, 15 December 1994.
- [2] ATLAS Letter Of Intent, CERN/LHCC/92-4, 1 October 1992.
- [3] Performance of a Large Scale Prototype of the ATLAS Accordion Electromagnetic Calorimeter, D. M. Gingrich et al, The RD-3 Collaboration, CERN-PPE 95-35
- [4] Measurement and control of the ATLAS electromagnetic calorimeter lead plates, B. Canton et al, ATLAS Internal Note LARG-NO-009, December 1994.

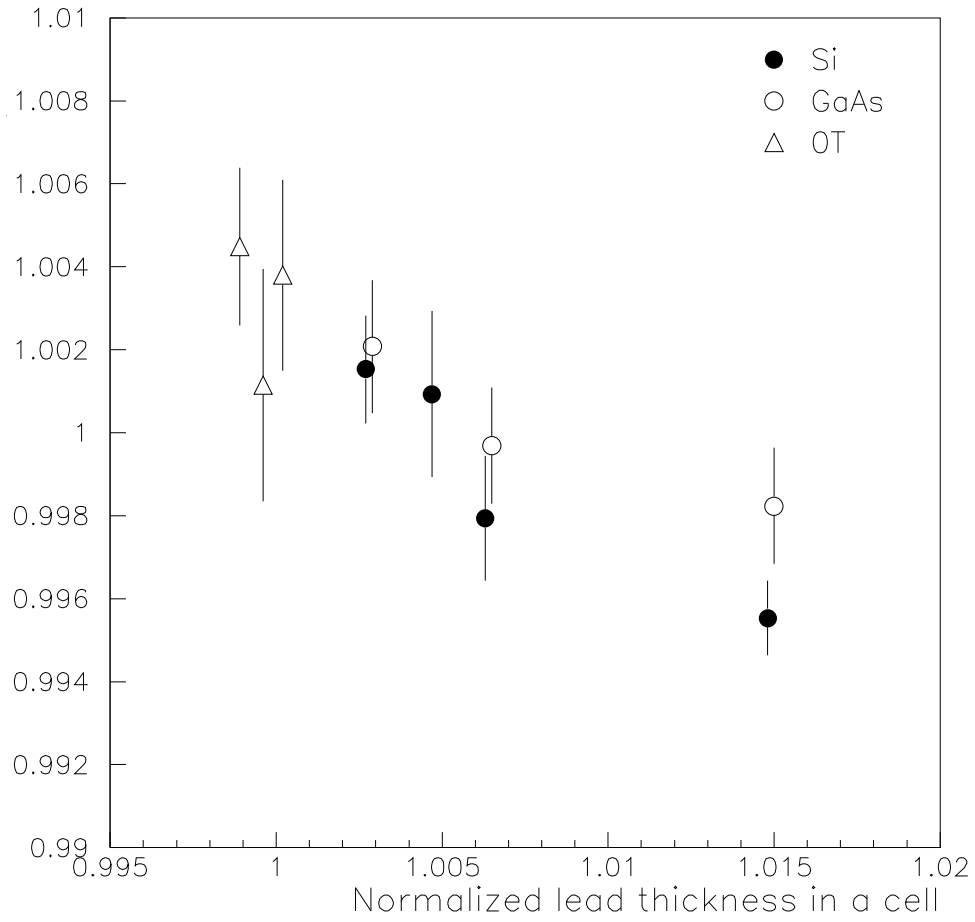

Figure 1: The 2m RD3 1992 prototype response to high energy electrons as a function of the lead thickness, normalized to the overall average.

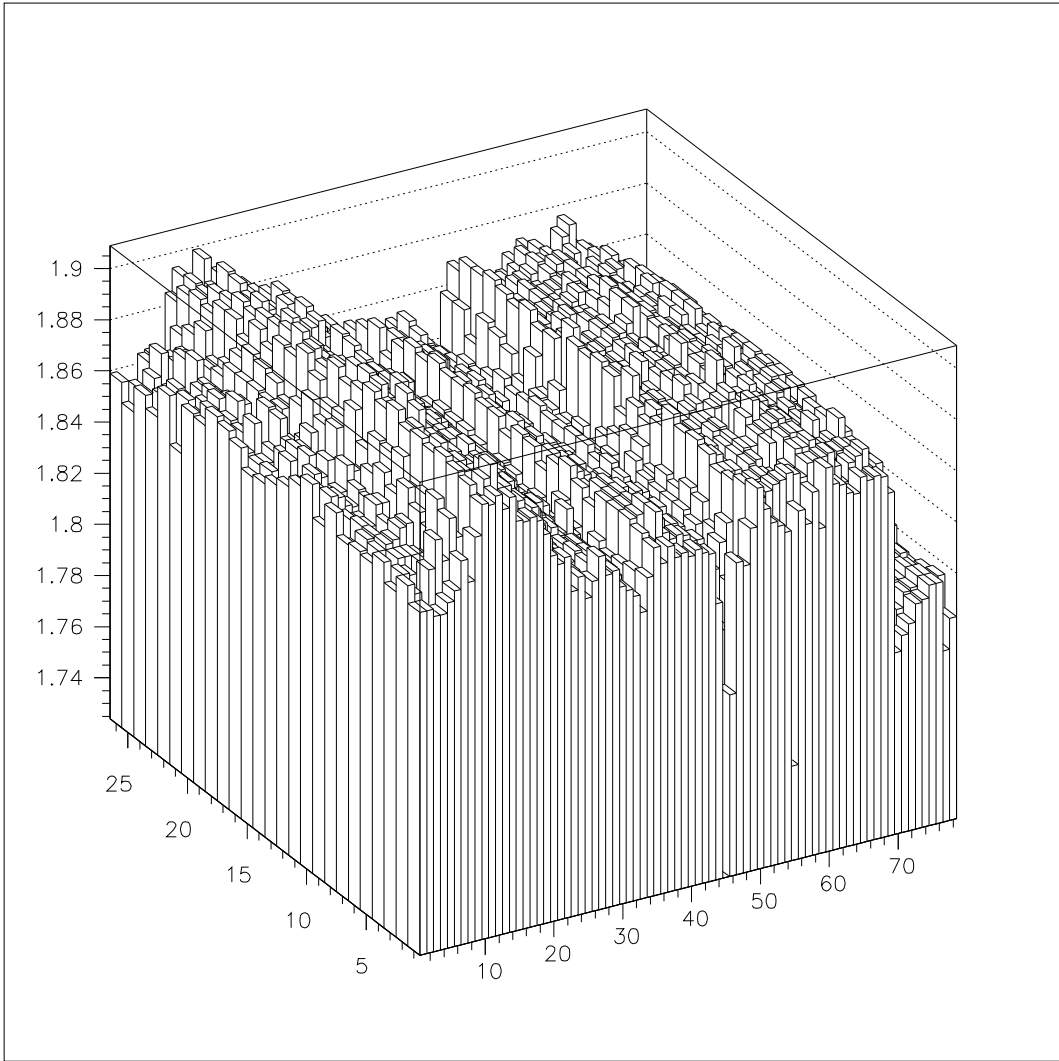

Figure 2: Map of a 1.8 mm thick European rectangular plate (corresponding to three square plates). One clearly distinguishes structures parallel to the rolls of the rolling machine. The axes are labelled in 2 cm units.

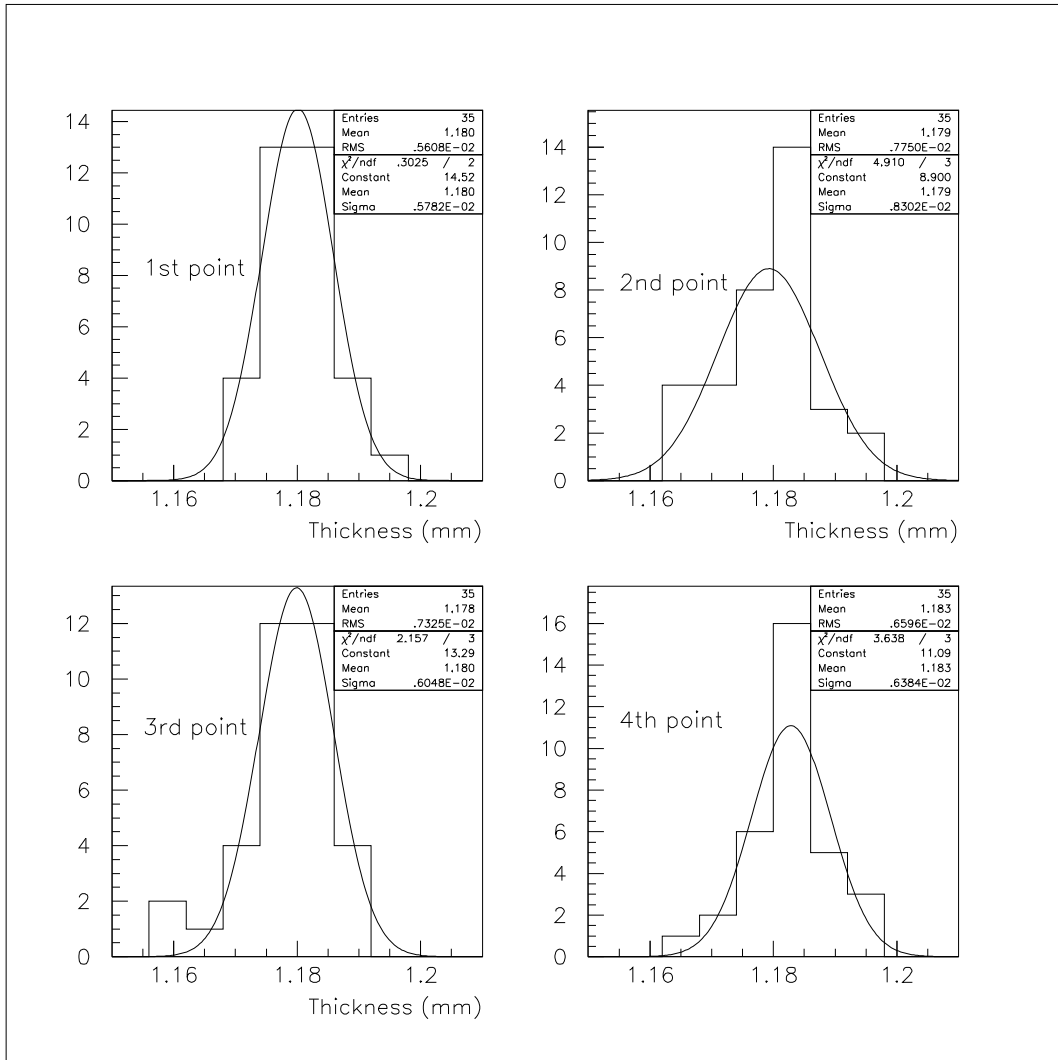

Figure 3: Distribution of the reference measurements for the 1.2 mm thick trapezoidal plates. Similar results were obtained for the other types of plates (1.8 mm trapezoids, 1.2 and 1.8 mm squares)

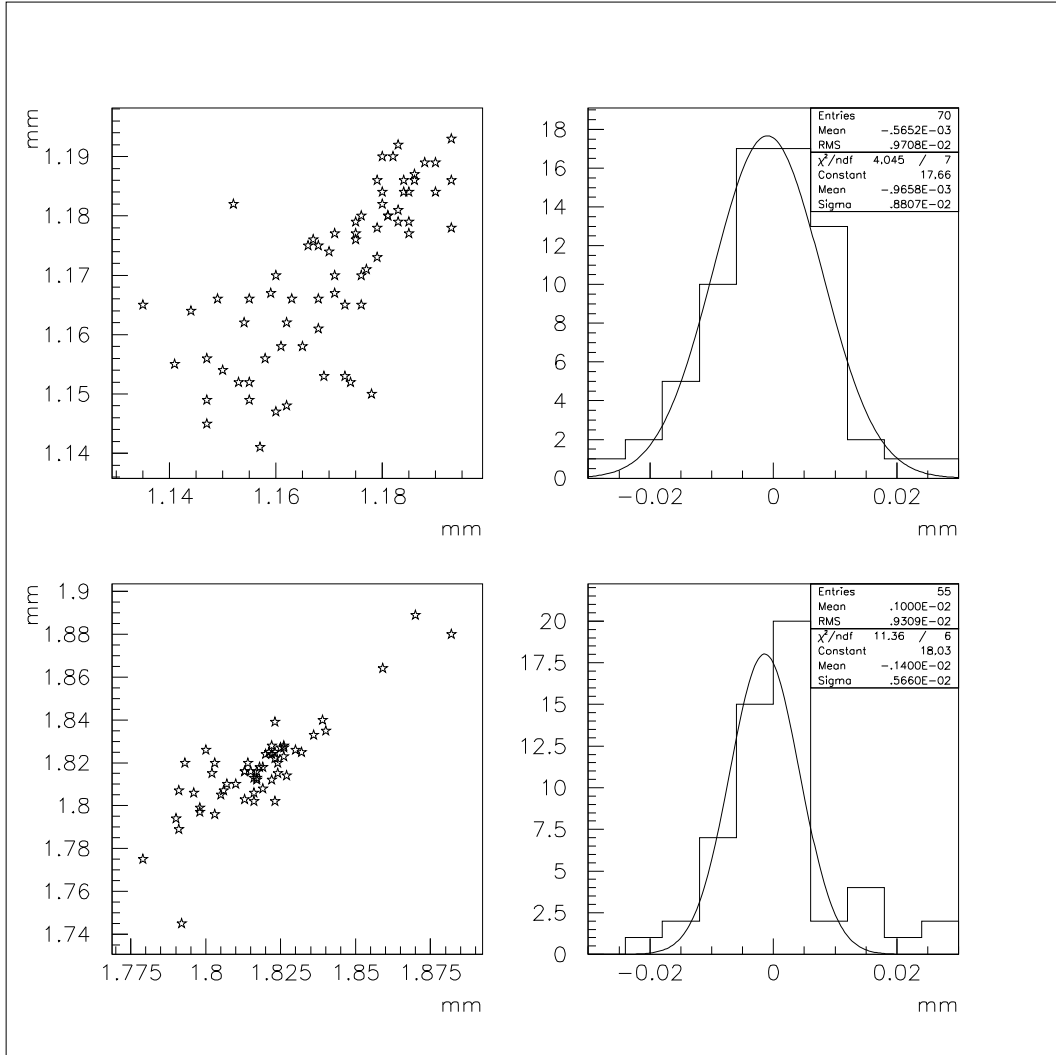

Figure 4: Distribution of the differences between two redundant measurements done on the same point. Upper histograms are for 1.2 mm trapezoidal plates, lower for 1.8 mm trapezoidal plates. The left plots show the correlation between the two redundant measurements.

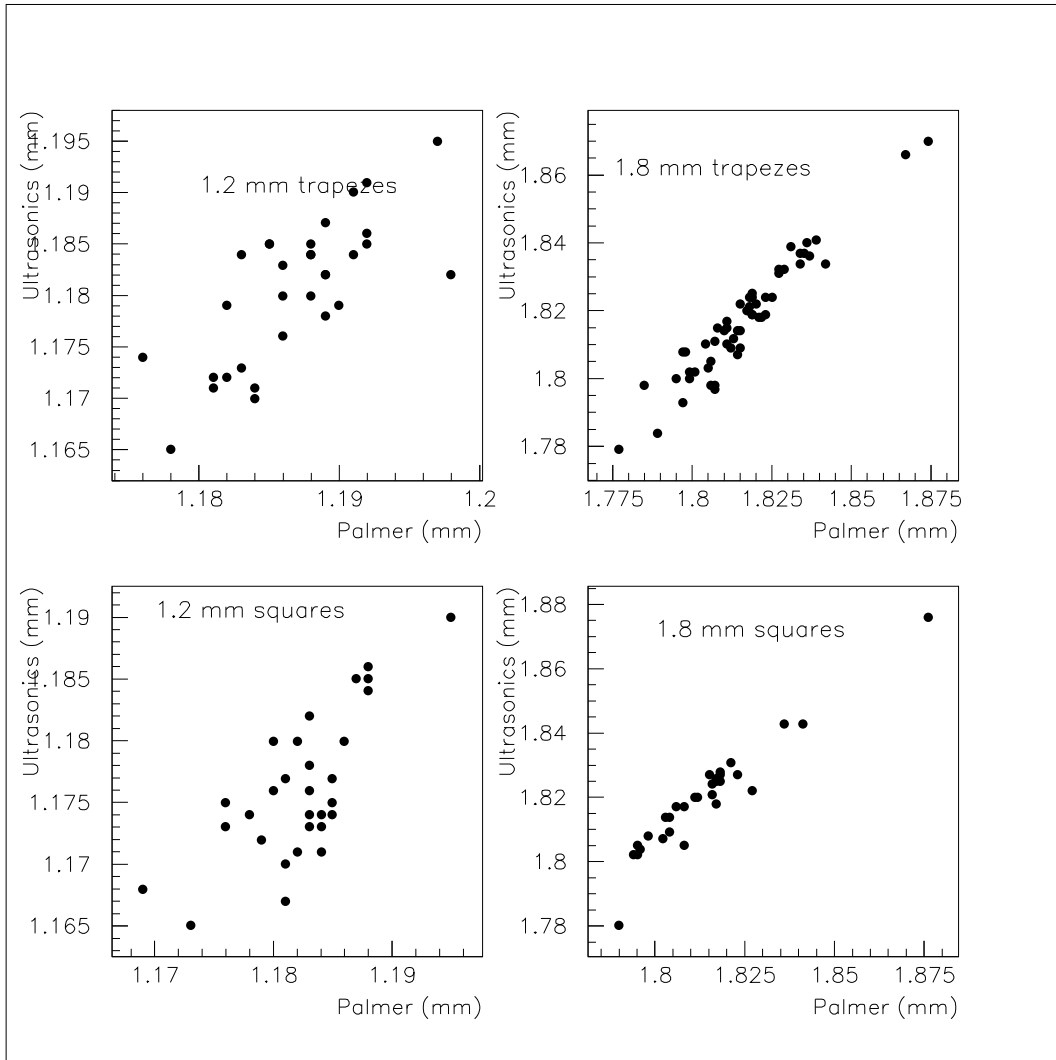

Figure 5: Correlation between the measurements taken with the palmer and the measurements taken with the ultrasonic sensor.

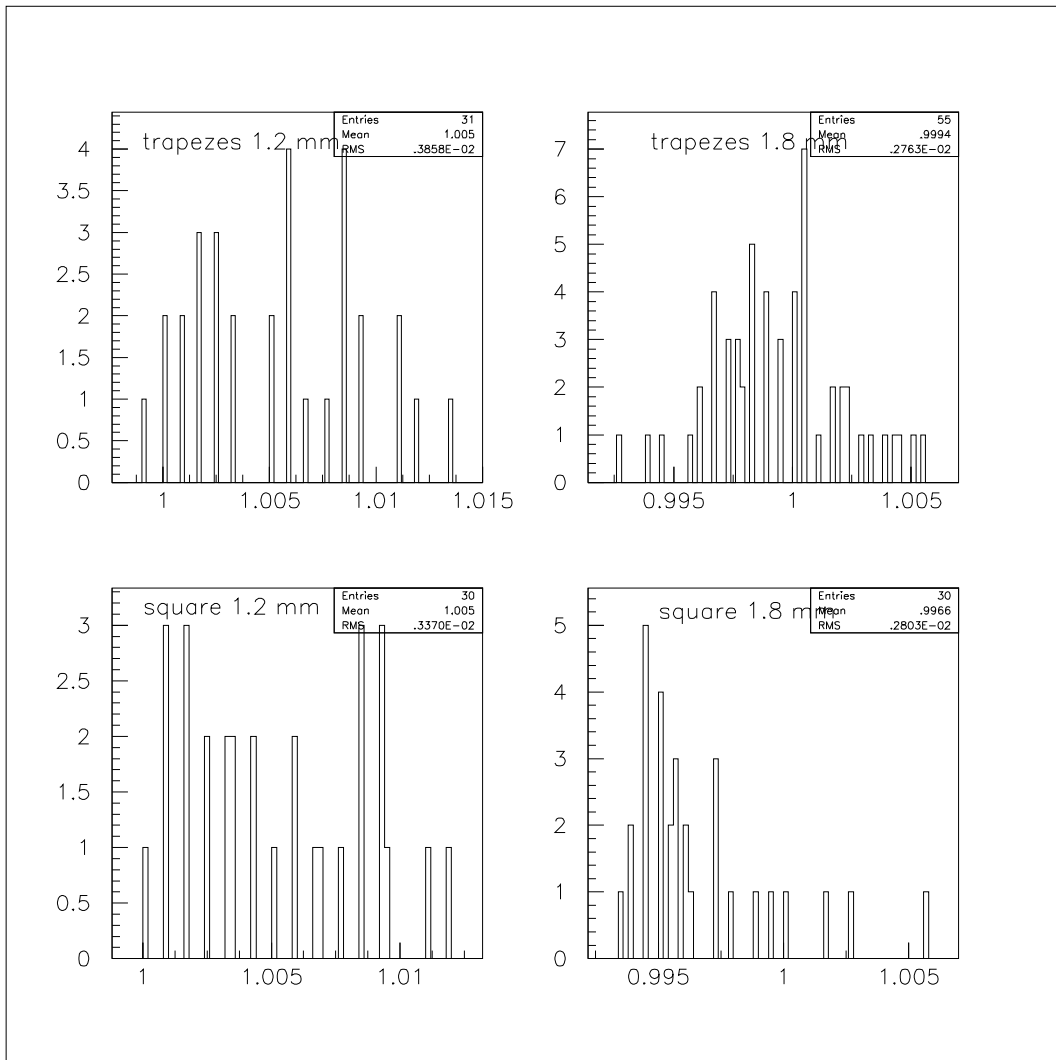

Figure 6: Distribution of the ratio of the palmer measurements and of the ultrasound measurements, before calibration.

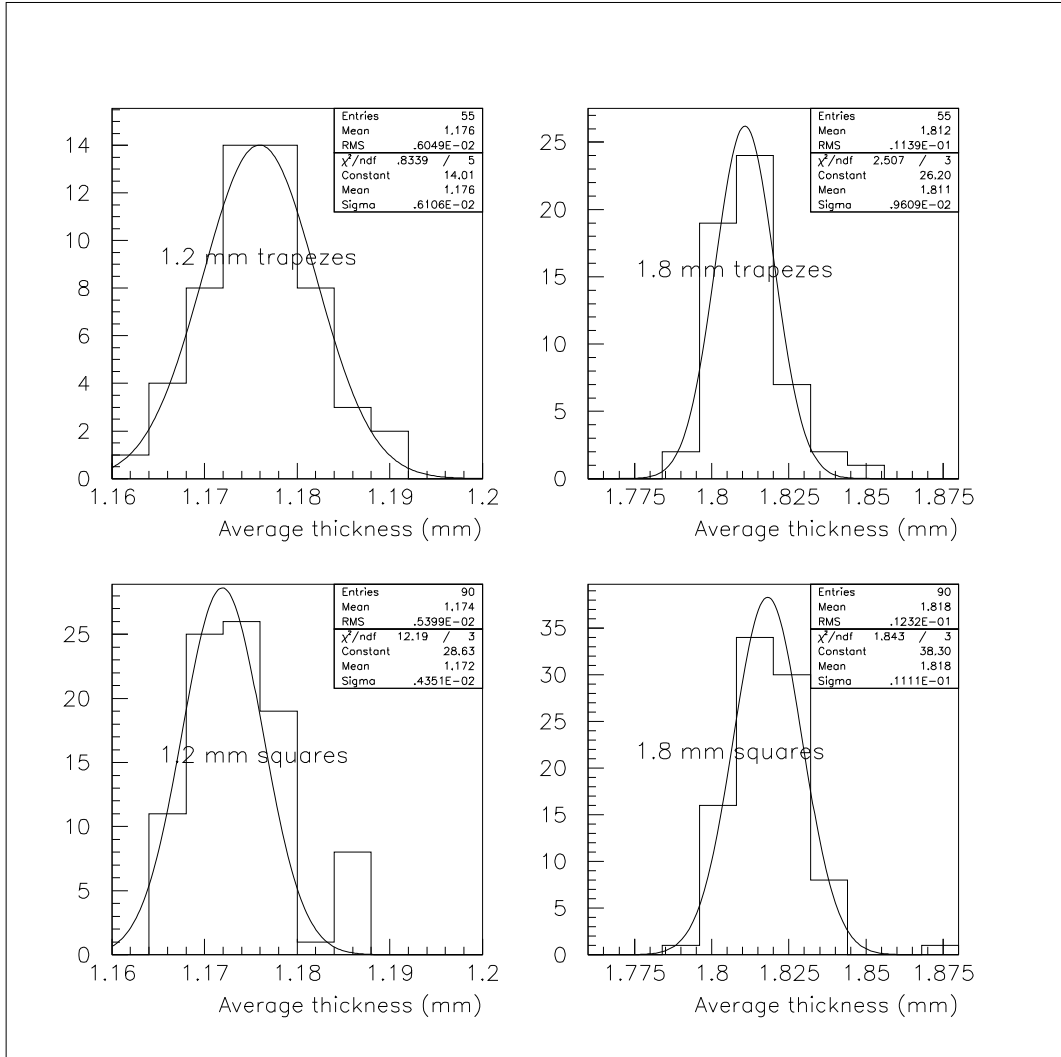

Figure 7: Distribution of the average thickness for each type of plates.

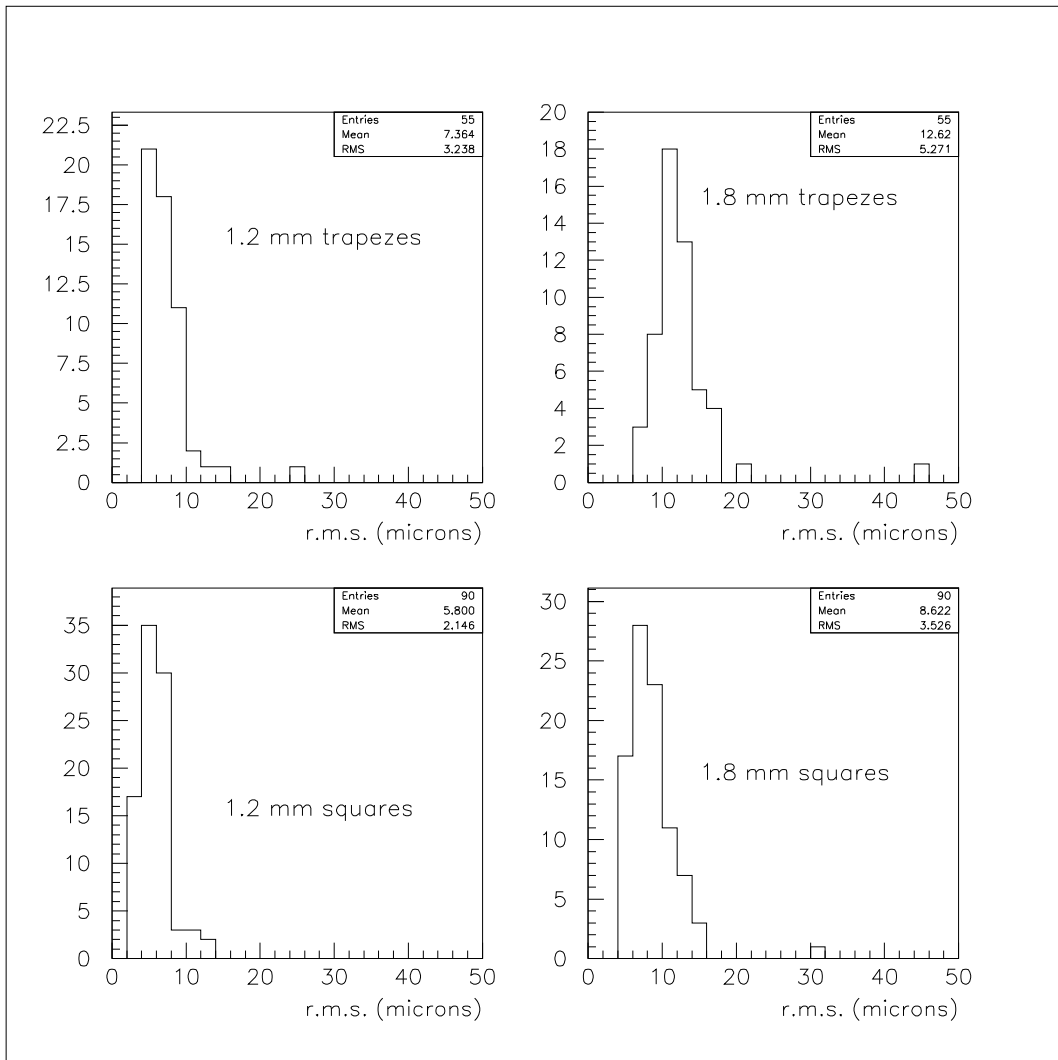

Figure 8: Distribution of the r.m.s. of the thickness measurements for each type of plates.

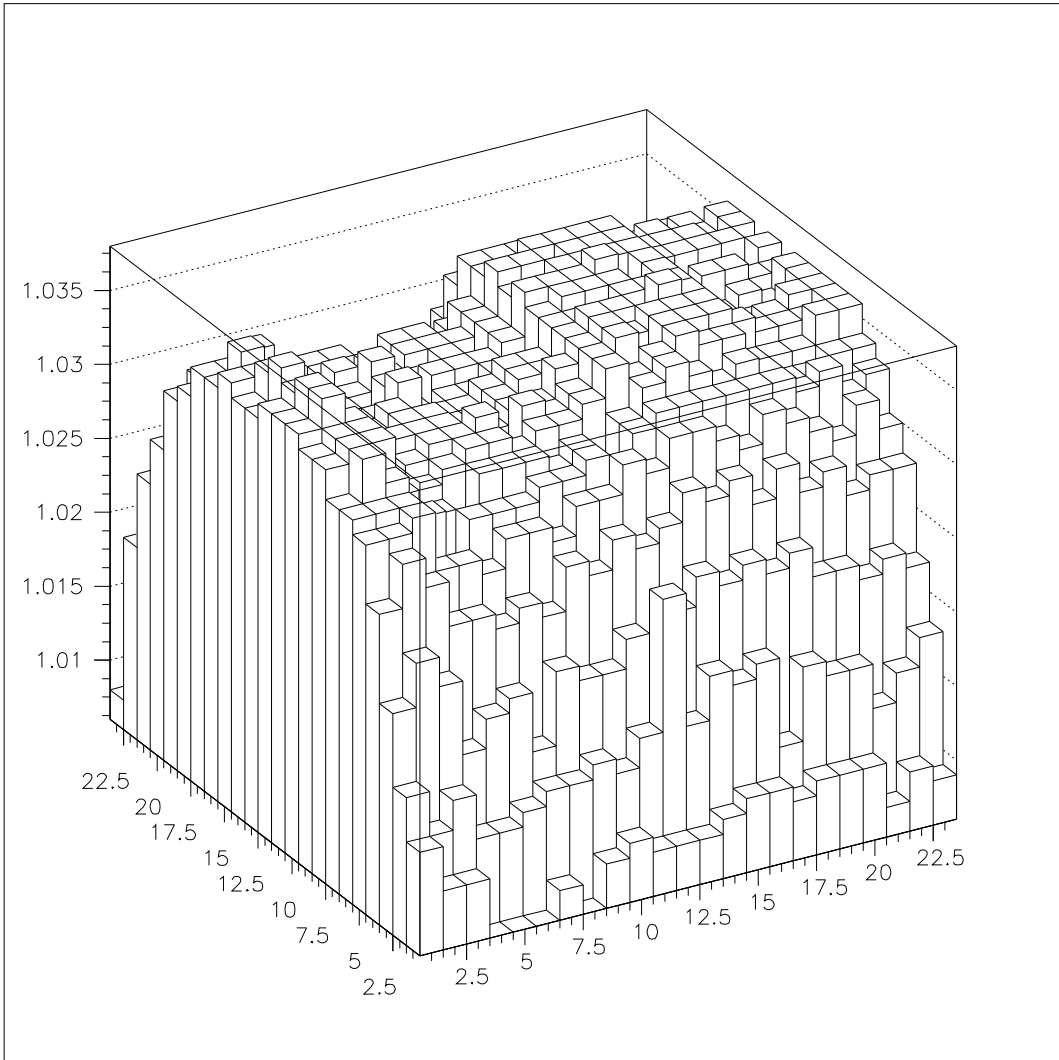

Figure 9: Map of a 1.0 mm thick American rectangular plate The axes are labelled in 1 inch units (2.54 cm).

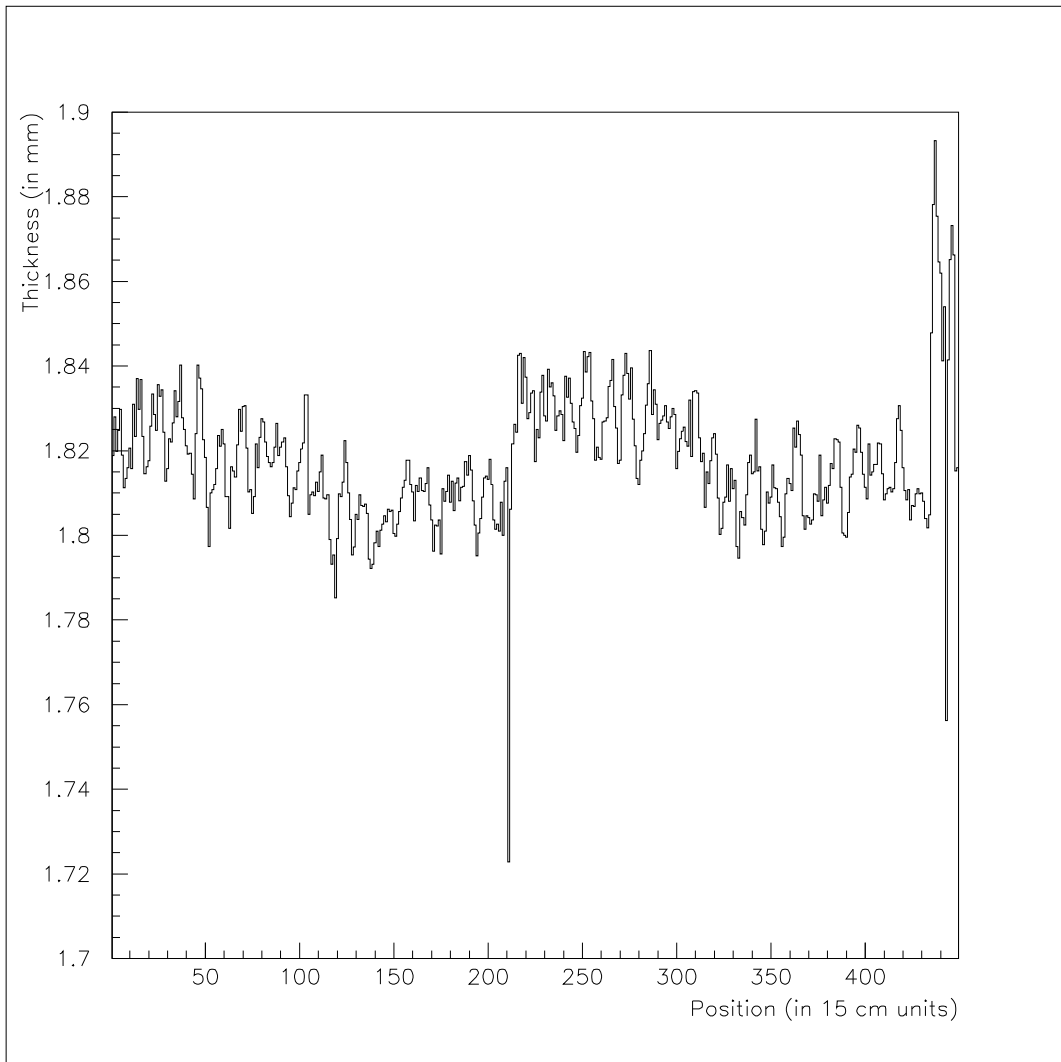

Figure 10: Projection along the rolling axis of all the maps of the 1.8 mm square plates put one after the other.