

ОБЪЕДИНЕННЫЙ
ИНСТИТУТ
ЯДЕРНЫХ
ИССЛЕДОВАНИЙ

Дубна

ff

E1-97-59

M.I.Krivopustov, J.Adam, V.Bradnova, R.Brandt¹, V.S.Butsev,
P.I.Golubev, V.G.Kalinnikov, B.A.Kulakov,
E.-J.Langrock¹, G.Modolo², M.Ochs¹, R.Odoj², A.N.Premyshev,
V.S.Pronskikh, Th.Schmidt¹,
V.I.Stegailov, J.S.Wan^{1,3}, V.M.Zupko-Sitnikov

FIRST EXPERIMENTS ON TRANSMUTATION
STUDIES OF IODINE-129 AND NEPTUNIUM-237
USING RELATIVISTIC PROTONS OF 3.7 GeV

Submitted to «Journal of Radioanalytical and Nuclear Chemistry»

¹Kernchemie, Philipps-Universität, Marburg, Germany

²Forschungszentrum Jülich, Germany

³Northwest Institute of Nuclear Technology, Xian, China



5w9728

1997

Introduction

Recently, the question of the transmutation of long-lived radioactive waste has attracted considerable interest. During the production of electric power in nuclear power stations, a considerable fraction of the original fissionable material, for example uranium, is transformed into higher actinides (Np, Pu, Am, Cm) and fission fragments. The long-lived actinides (^{237}Np , $^{239-242}\text{Pu}$, $^{241,243}\text{Am}$ and ^{244}Cm) and a few long-lived fission fragments, ^{129}I and ^{99}Tc among them, constitute a formidable problem for mankind. Due to their long half-life (much larger than 100 years) it is difficult to find a final depository for them, which should be stable for geological times. Therefore attempts have been made to isolate these long-lived nuclides from other fission fragments chemically — a process called partition. Then one tries to transmute them into stable or shorter-lived nuclides. A comprehensive description of the field is given by Schapira [1]. There are two options to carry out the transmutation:

i) burn-up of long-lived nuclides in nuclear reactors with $k \geq 1$ (k — neutron multiplication factor);

ii) burn-up of long-lived nuclides in subcritical assemblies with $k < 1$.

This second process was suggested by Tolstov [2], Bowman et al. [3], Rubbia et al. [4], among others. We are reporting here first experiments on the transmutation of ^{129}I and ^{237}Np using relativistic protons. Konings et al. [5,6] carried out similar studies on ^{129}I using nuclear reactors.

In all of these studies, use is made of iodine salts obtained from nuclear reprocessing plants. These I-salts contain two isotopes: ^{127}I (stable) and ^{129}I ($T_{1/2} = 1.57 \cdot 10^7$ y). The radioactive isotope is abundant as 85%. Exposing such I-salts to neutrons, one can study the following reactions easily, using (high purity) Ge gamma spectroscopy [7]:

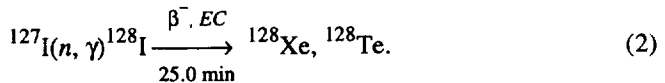
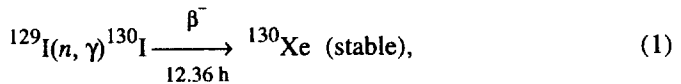

Similarly, nuclear reprocessing plants produce isotopically pure ^{237}Np ($T_{1/2} = 2.1 \cdot 10^6$ y), which again can be transmuted by neutrons:

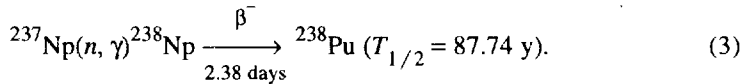

The neutrons needed for this transmutation were produced by the interaction of 3.7 GeV protons in extended Pb-targets. Then the neutrons were moderated within paraffin. The experiments were carried out in November 1996 at the Synchrophasotron (LHE, JINR, Dubna, Russia).

Experiments

The experiments are carried out in the framework of general transmutation studies by Brandt et al. [8(a)], using relativistic protons and heavy ions at energies up to 3.7 GeV/nucleon.

The target used is shown in Fig.1(a): a block of 20 cm Pb, composed of 20 disks, each being of diameter 8 cm and 1 cm thick, is irradiated with a well-focused beam of 3.7 GeV protons during 15 minutes with a total intensity of $1.24 \cdot 10^{13}$ protons. The full width at the half-maximum of the beam is less than 15 mm. The Pb-block is surrounded by a paraffin moderator 6 cm thick. On top of the moderator one finds 1 g U-salt samples, as well as 0.425 g ^{129}I (in form of NaI) and 0.742 g ^{237}Np (in form of NpO_2). The construction of radioactive samples of I and Np are well-sealed in Al-capsules, as shown in Fig.2. They were prepared by the Institute of Physics and Power Engineering (Obninsk, Russia). In addition to the two ^{129}I - and ^{237}Np -samples shown, two identical samples were irradiated directly in the 3.7 GeV proton beam during a separate irradiation.

In this report we concentrate our attention on the results obtained with the samples shown in Fig.1(a). The results of the experiment the scheme of which is shown in Fig.1(b) will be published soon. After the irradiation, the radioactive samples were placed in front of a HPGe-detector in order to study the gamma activity. As both ^{129}I - and ^{237}Np -samples are fairly radioactive even without any neutron activation, the samples were placed at a distance of 20 cm from the detector. In case of the ^{237}Np -sample a Pb-plate 1 cm thick is placed between the sample and the detector, reducing considerably the low energy gamma activity, as shown in Fig.3. We identified the (n, γ) -reaction products ^{130}I and ^{238}Np as shown in the decay curves of these two nuclides in Fig.4. Further analysis for the

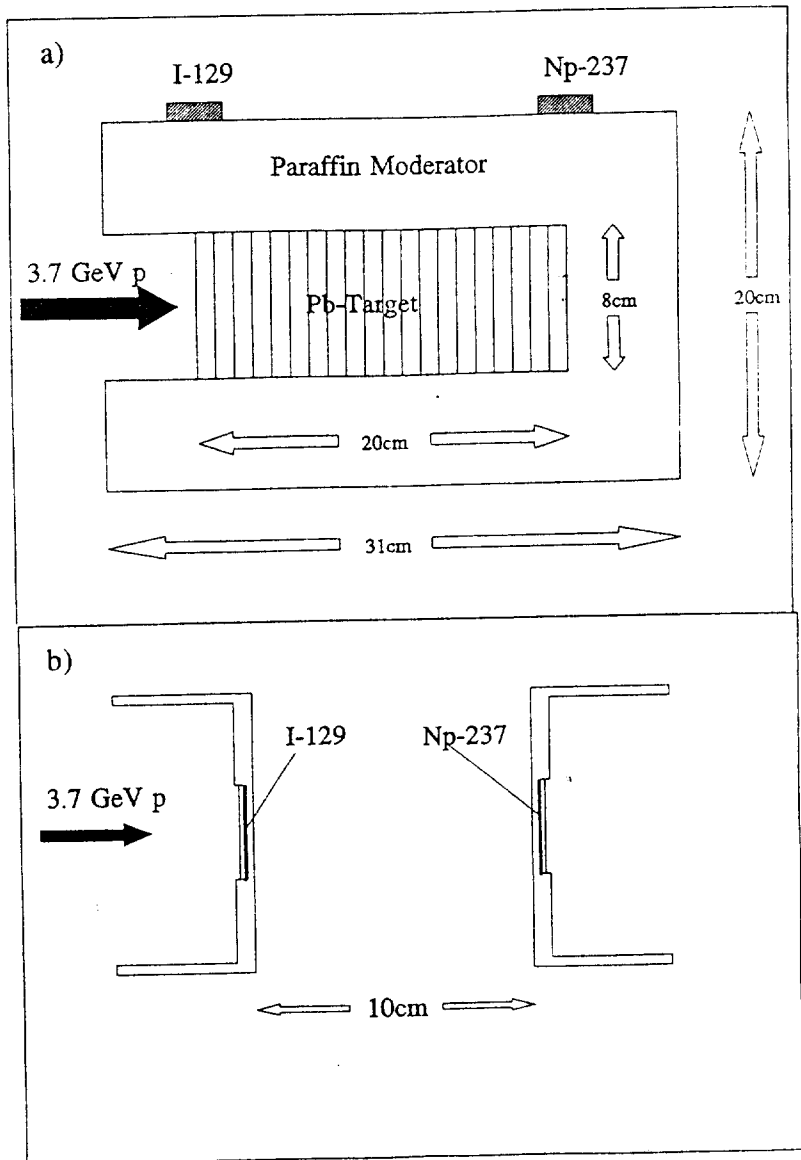

Fig.1. The target setup (also showing ^{129}I - and ^{237}Np -samples):
 a) explanation is given in the text;
 b) the scheme of the experiment on transmutation on the basis of spallation process

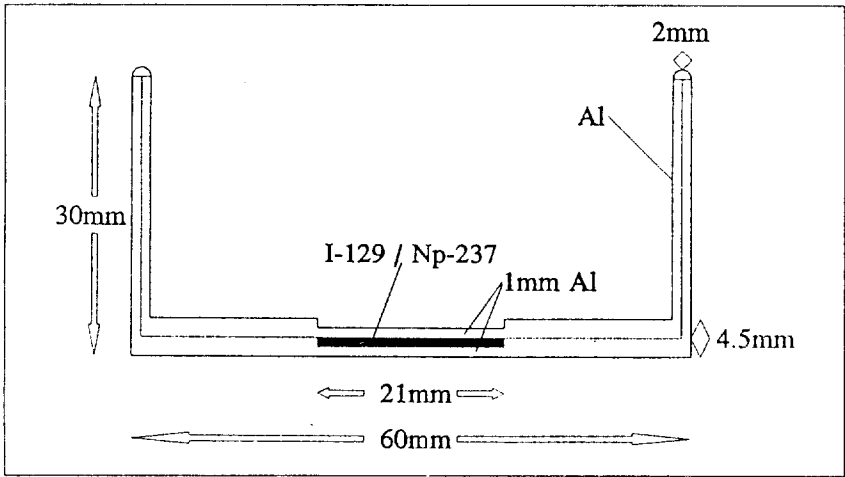

Fig.2. The hermetic construction of the samples of radioactive iodine-129 and neptunium-237 isotopes. These samples were prepared by the Institute of Physics and Power Engineering in Obninsk, Russia

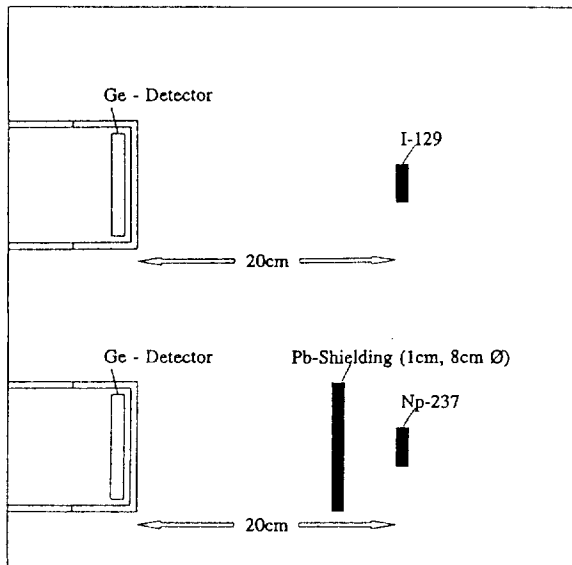

Fig.3. The HPGe-gamma-detector without (^{129}I) and with the 1 cm Pb-absorber (^{237}Np)

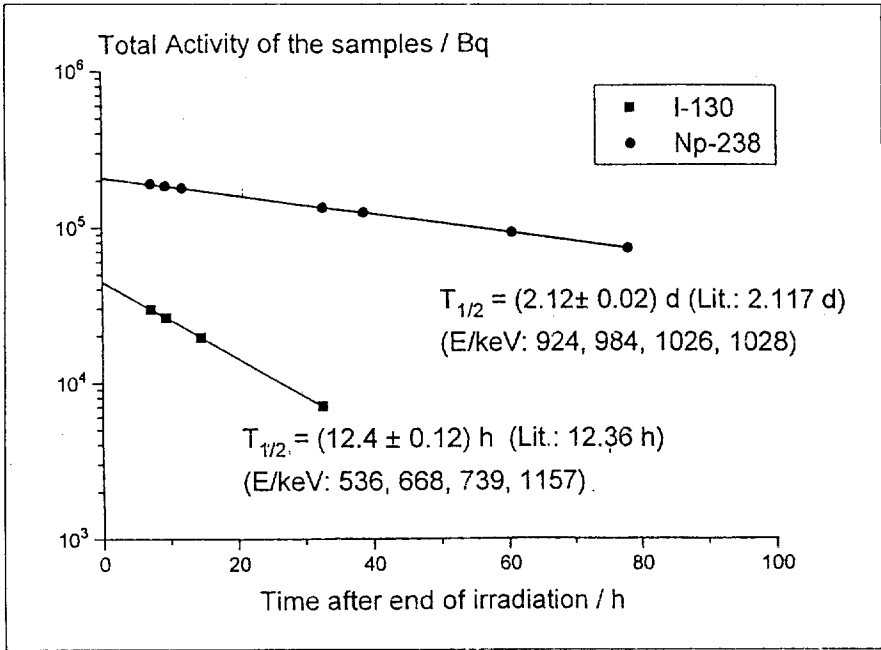

Fig.4. The decay curves of iodine-130 and neptunium-238, formed in the reactions $^{129}\text{I}(n, \gamma)^{130}\text{I}$ and $^{237}\text{Np}(n, \gamma)^{238}\text{Np}$

gamma-spectra is state of the art as described in references [7—9]. The results are expressed in terms of «breeding rates» B , defined as follows [9(b)]:

$$B = \frac{\text{number of produced particles}}{(\text{single incident ion}) \cdot (1\text{g-sample})} \quad (4)$$

This term B is defined strictly in an empirical manner: for the reaction (1) it means that 0.425g ^{129}I is placed at the geometrical position, given in Fig.1(a), irradiated with 3.7 GeV protons.

Results and Discussion

The analysis of this experiment gave results for the reactions (1) and (3), and in addition for the reaction:

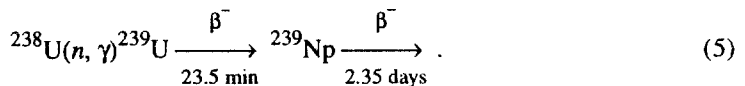

The resulting B -values are given the Table. In addition, one can compare the corresponding cross sections $\sigma(n, \gamma)$ for the two reactions studied using the following equation:

$$\frac{B_1}{N_T(1) \cdot \sigma_1(n, \gamma)} = \frac{B_2}{N_T(2) \cdot \sigma_2(n, \gamma)} \quad (6)$$

as all targets are exposed at the same geometrical position and to the same neutron fluence. Assuming $\sigma(n, \gamma) = 6.15$ b for thermal neutrons in the reaction $^{127}\text{I}(n, \gamma)^{128}\text{I}$, one obtains two further $\sigma(n, \gamma)$ -values, as given in the Table. The corresponding cross sections for the reaction (2) have been reported in ref.[8].

Table. Observed breeding rates B and measured $\sigma(n, \gamma)$ values for some transmutation reactions

Reaction	$^{237}\text{Np}(n, \gamma)^{238}\text{Np}$	$^{127}\text{I}(n, \gamma)^{128}\text{I}$	$^{129}\text{I}(n, \gamma)^{130}\text{I}$
B (10^{-4})	44 ± 4	1.9 ± 0.2	2.7 ± 0.4
$\sigma(n, \gamma)$, (barn)	140 ± 30 180 [10]	6.15 ± 1.23	10 ± 2 10.3 [10]

Finally we can answer to some extent the question: How long one must expose ^{129}I - or ^{237}Np -samples to neutrons before substantial amounts are transmuted into stable or short-lived nuclei? Taking the setup as shown in Fig.1, one can estimate that a 1 mA accelerator of 3.7 GeV protons operating one year should transmute

- i) approximately 1% of ^{129}I per year,
- ii) approximately 30% of ^{237}Np per year.

In this estimation we did not consider any technical problem, such as the heat-shielding of the target at 1 mA proton intensity or the stability of the NaI-compound in its containment during the irradiation. Both problems are nontrivial. In this paper we only wanted to give some indications of the transmutation capacity of our target system to actually transmute ^{129}I and ^{237}Np into stable or short-lived activities.

Acknowledgement

The authors want to thank the operating crew at the Synchrotron of the Laboratory of High Energies, JINR (Dubna, Russia) for the irradiations and Academician A.M.Baldin as well as Professors A.N.Sissakian, A.I.Malakhov,

I.B.Issinsky and A.D.Kovalenko for their continued support of this work. The Marburg team is grateful for the opportunity to train young scientists at LHE and to enjoy the cordial hospitality of their Russian colleagues in Dubna.

The authors thank Prof. Yu.A.Panebratsev, Drs. S.S.Shimansky and Yu.S.Averichev for their support in carrying out the irradiations of the targets at the F3 focus of the DISK installation.

We are also grateful to Profs. N.M.Russakovich and V.B.Brudanin for their support of this work.

The research described in this publication was made possible in part by Grant from the Russian Foundation for Fundamental Research.

One of the authors (M.I.K.) thanks the DFG-Deutsche Forschungsgemeinschaft (Bonn, Germany) for the support of his stay at the Kernchemie-Institut, Philipps-Universität (Marburg, Germany).

References

1. Schapira J. — Long Term Nuclear Waste Management: Present Status and Alternatives. Nucl. Instrum. and Methods, 1989, v.A280, p.568—582.
2. Tolstov K.D. — JINR Preprint 18-89-778, Dubna, 1989.
3. Bowman C.D. et al. — Nuclear Energy Generation and Waste Transmutation Using an Accelerator-Driven Intense Thermal Neutron Source. Nucl. Instr. and Methods, 1992, v.A320, p.336—367.
4. Rubbia C. et al. — Experimental Study of the Phenomenology of Spallation Neutrons in a Large Lead Block. CERN/SPSLC 95-17, 1995.
5. Konings R.J.M. et al. — Technological Aspects of Transmutation of Technetium and Iodine. In: Proc. of the Intern. Conf. and Technology Exposition on Future Nuclear Systems, GLOBAL 93, Seattle, Washington, Sept. 12-17, 1993, p.1260.
6. Konings R.J.M. et al. — Irradiation Tests of Transmutation of the Fission Products Technetium and Iodine. In: Proc. of the Intern. Conf. on Evaluation of Emerging Nuclear Fuel Cycle Systems, GLOBAL 95, Versailles, France, Sept. 11-14, 1995, p.1631—1637.
7. Adam J. et al. — JINR Comm. P6-86-320, Dubna, 1986.
8. a) Brandt R. et al. — Study of Neutron Production and Transmutation Possibilities of Some Isotopes in Experiments at the Synchrotron at JINR (Dubna). In: Proc. Intern. Workshop «Nuclear Methods for Transmutation of Nuclear Waste: Problems. Perspectives. Cooperative Research», 29-31 May, 1996, Dubna, Russia (in print);
b) Ochs M. — Dissertation, Fachbereich Physikalische Chemie, Philipps-Universität, Marburg, 1997.
9. a) Brandt R. et al. — Phys. Rev., 1992, v.C45, p.1194-1208;

- b) Bisplinghoff B. et al. — *Isotopenpraxis*, 1994, v.30, p.29-37;
Brandt R. et al. — *JINR Preprint E1-95-502*, Dubna, 1995 (submitted to «*Phys. Rev. C*»).
10. *Tables of Physical Values. Handbook.* Editor I.K.Kikoin, Moscow, Atomizdat, 1976, p.904-929;
Mughabhab S.F. et al. — *Neutron Resonance Parameters and Thermal Cross Sections.* N.Y. Acad. Press, 1981.

Received by Publishing Department
on February 25, 1997.

Кривоустов М.И. и др.

E1-97-59

Первые эксперименты по изучению трансмутации йода-129 и нептуния-237 с использованием релятивистских протонов с энергией 3,7 ГэВ

Приведены результаты первых экспериментов по трансмутации долгоживущих радиоактивных отходов йод-129 и нептуний-237, выполненных на пучке протонов с энергией 3,7 ГэВ. Релятивистские протоны генерируют в веществе массивной свинцовой мишени интенсивные потоки нейтронов, которые замедляются в парафине и используются для трансмутации $^{129}\text{I}(n, \gamma)^{130}\text{I}(\beta^-) \rightarrow ^{130}\text{Xe}$ (стаб.) и $^{237}\text{Np}(n, \gamma)^{238}\text{Np}(\beta^-) \rightarrow$. Идентификация изотопов ^{130}I ($T_{1/2} = 12,36$ ч) и ^{238}Np ($T_{1/2} = 2,117$ сут.) проведена ядерно-спектроскопическим методом. Сечения трансмутации этих изотопов составляют $\sigma(^{129}\text{I}(n, \gamma)) = (10 \pm 2)$ б и $\sigma(^{237}\text{Np}(n, \gamma)) = (140 \pm 30)$ б. Эксперименты по изучению трансмутации выполнены в ноябре 1996 г. на синхрофазотроне Лаборатории высоких энергий ОИЯИ (Дубна).

Работа выполнена в Лаборатории высоких энергий ОИЯИ.

Препринт Объединенного института ядерных исследований. Дубна, 1997

Krivooustov M.I. et al.

E1-97-59

First Experiments on Transmutation Studies of Iodine-129 and Neptunium-237 Using Relativistic Protons of 3.7 GeV

First experiments on the transmutation of long-lived ^{129}I and ^{237}Np using relativistic protons of 3.7 GeV are described. Relativistic protons generate in extended Pb-targets substantial neutron fluences. These neutrons get moderated in paraffin and are used for transmutation as follows: $^{129}\text{I}(n, \gamma)^{130}\text{I}(\beta^-) \rightarrow ^{130}\text{Xe}$ (stable) and $^{237}\text{Np}(n, \gamma)^{238}\text{Np}(\beta^-) \rightarrow$. The isotopes ^{130}I ($T_{1/2} = 12.36$ h) and ^{238}Np ($T_{1/2} = 2.117$ days) were identified radiochemically. One can estimate the transmutation cross section (n, γ) in the given neutron field as $\sigma(^{129}\text{I}(n, \gamma)) = (10 \pm 2)$ b and $\sigma(^{237}\text{Np}(n, \gamma)) = (140 \pm 30)$ b. The experiments were carried out in November 1996 at the Synchrophasotron, LHE, Dubna, Russia.

The investigation has been performed at the Laboratory of High Energies, JINR.

Preprint of the Joint Institute for Nuclear Research. Dubna, 1997

Редактор Е.И.Кравченко. Макет Р.Д.Фоминой

Подписано в печать 10.04.97
Формат 60 × 90/16. Офсетная печать. Уч.-изд.листов 0,87
Тираж 420. Заказ 49869. Цена 1044 р.

Издательский отдел Объединенного института ядерных исследований
Дубна Московской области