

СООБЩЕНИЯ
ОБЪЕДИНЕННОГО
ИНСТИТУТА
ЯДЕРНЫХ
ИССЛЕДОВАНИЙ

Дубна

Σ E

E9-96-492

O.N.Borisov; N.A.Morozov, E.V.Samsonov, I.V.Titkova,
S.B.Vorozhtsov, E.Bakewicz*, R.Taraszkiewicz*

FEASIBILITY STUDY
OF THE BEAM EXTRACTION
FROM THE AIC-144 CYCLOTRON



*Henryk Niewodniczanski Institute of Nuclear Physics, Krakow, Poland

swg721

1996

Introduction The purpose of this study is to propose an efficient beam extraction system for the AIC-144 cyclotron, IFJ, Krakow, Poland [1].

All the pertinent parameters of the cyclotron became available to the design team only quite a short time ago. Hence, the proposed solution to the problem under consideration should be regarded as a very preliminary one.

Performance requirements The following extracted beams properties were assumed

Particle	Parameter	Min	Feasible	Max	Option
Proton	Energy (MeV)	20	22.5	60	60.5
	Intensity (μA)	1	-	-	-
Deuteron	Energy (MeV)	20	23.5	30	-
	Intensity (μA)	25	-	-	-
α -particle	Energy (MeV)	-	-	-	max
	Intensity (μA)	-	-	-	10

The feasibility of the low energy extraction is limited by beam losses on the passage of certain resonances in the tune diagram. An optional requirement, concerning α -particle, implies that the extraction will be performed by a device, designed only for proton and deuteron. It was also understood, that the intensity requirement will be met if a sufficient internal beam current is accelerated.

Existing extraction system analysis There are several factors which have precluded the highly efficient particle extraction within the existing system: rather low beam quality due to a large (1.2 mT) amplitude of the first harmonic of the magnetic field at injection, low energy gain per turn ($V_{dee} \leq 50$ kV), limited voltage (≤ 55 kV) at the electrostatic deflector to direct the accelerated particles away from the cyclotron magnetic field. An extraction device similar to the AIC-144 was also exploited in the U-120-M cyclotron (Rzez, Czech Republic) and showed rather low ($15 \div 20$ %) efficiency, i.e. extracted to internal current ratio [2].

New extraction system The layout of the new extraction system is given in Fig. 1 and Fig 2.

A precession of particle orbit centers, widely exploited in the extraction of positive ions from compact cyclotrons, has been chosen as a solution of the problem. The precession manifests itself in the fringe magnetic field of the cyclotron due to the well controlled first harmonic ($0.1 \div 0.5$ mT) of the magnetic field perturbation, which produces radial coherent oscillations of the amplitude ($5 \div 10$) mm. The choice of the precessional extraction method is based on the fact that higher final energy is reached in a given cyclotron field. It also allows the largest radius, where the ESD entrance has to be placed. Accordingly, the smallest values of the electric field strength in the ESD could be exploited.

Computer simulation The below described procedure was followed in the calculations. In the central region the spatial distribution of the electric field and beam centering were calculated. In the main acceleration region the magnetic field maps and the corresponding beam transmission were calculated. Near the extraction radius various methods

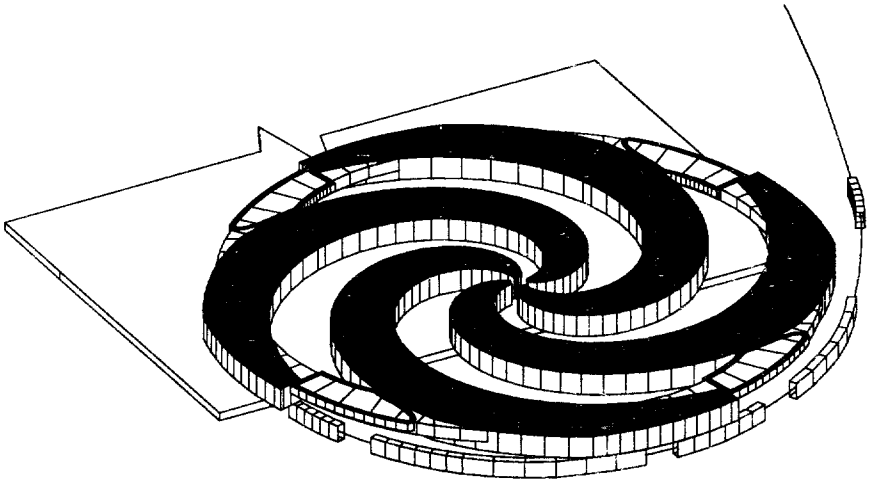

Figure 1: AIC-144 cyclotron magnetic structure with the extraction system shown

to enhance the orbit separation were considered. A precessional method has been chosen as the most suitable for the case. Realistic magnetic field distributions near the extraction radius and along the ejected particle trajectory were interpolated from the measured and calculated maps. The parameters of the deflector and the system for coherent amplitude build up were defined. The magnetic and electrostatic field contribution from the above mentioned devices were included in the main field maps. Various beam deflection simulations were performed in the thus reconstructed fields. We discuss all these steps briefly below.

Magnetic field structure Prior to the beam dynamics analysis the magnetic field maps for various modes of acceleration should be known. These maps cover both the main acceleration region and the magnet fringe field zone.

Field shaping in the acceleration region (isochronous curves) was performed with the help of the trim coils for protons of 69 MeV (main coil current $I_o=600$ A) and of 22.5 MeV ($I_o=120$ A) and deuterons of 30 MeV ($I_o=600$ A) and of 23.5 MeV ($I_o=285$ A). In the most difficult case (protons of 60 MeV) the accuracy of the mean field shaping was 1.5 mT at the level of 1.82 T. Using the proposed additional valley shims, the deviation of the field from the desired one could be decreased down to 0.1 mT.

In the central region by means of better accuracy in manufacturing of central sectors the amplitude of first harmonic was decreased from 1.2 mT to 0.7 mT. Another correction, down to 0.2÷0.3 mT, is under way.

Turn separation enhancement The system parameters were chosen mainly to provide extraction of 60 MeV protons because it is the most difficult case for the extraction process.

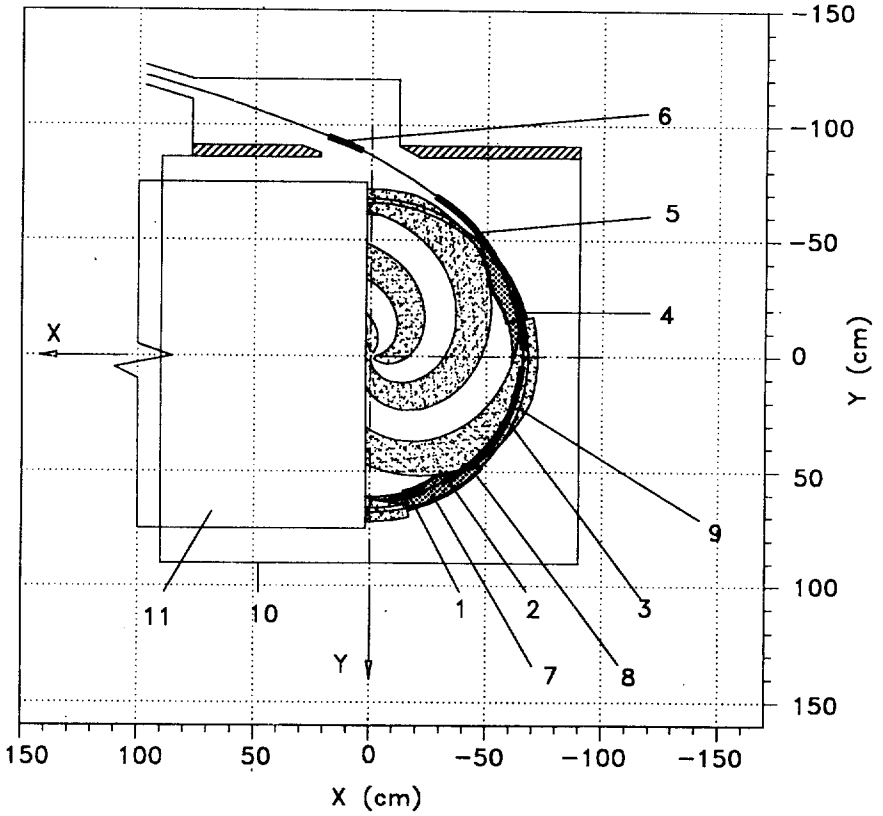

Figure 2: Extraction system layout. 1,2,3 - electrostatic deflector sections ESD-1,2,3; 4,5,6 - magnetic channel sections MC-1,2,3; 7 - valley shim; 8 - harmonic coil; 9 - spiral shim; 10 - vacuum chamber; 11 - dee

A set of particles with the initial radial amplitudes of 0, 1, 2, 3, 4 and 5 mm, axial amplitude of 1, 2 and 3 mm (emittance = $4.5 \pi \times \text{mm} \times \text{mrad}$), energy of 55 MeV, belonging to the beam bunch of 20° RF width, were traced through the extraction region. This rather good beam quality could be taken for the calculations as a result of the first magnetic field harmonic suppression in the central region and the centering and beam transmission studies.

Due to passing the $2Q_z=Q_r$ coupling resonance, with Q_r and Q_z the radial and axial oscillation frequencies, axial amplitudes of some particles increase and the extracted beam axial emittance goes up to $8 \pi \times \text{mm} \times \text{mrad}$. The optimal values of the first harmonic amplitude (0.2 mT) and its phase (170°) were obtained to provide ≈ 4 mm radial turn separation at the ESD mouth (azimuth 98°). The ESD entrance position should be at the radius 62.6 cm to reduce the beam losses at its septum down to $10 \div 15$ %, provided the septum width is 0.5 mm. The radial emittance of the beam equals $9 \pi \times \text{mm} \times \text{mrad}$ and energy is -60.08 ± 0.17 MeV there.

When simulating the extracting process of 22.5 MeV protons, the procedure similar to protons of 60 MeV was employed. Here, the main difference is higher maximal separation between two successive turns (≈ 11 mm). Of course, the following parameters of the extraction system should be adjusted as required: V_{de} , the first harmonic amplitude and its phase, ESD entrance position and aperture. But these values are less demanding than in the previous case. The same is valid for deuterons and α -particles within their specified energy range.

A new system of harmonic coils is proposed to produce the required magnetic field perturbation. It will be placed around the valley shims, in the radial range $61 \div 68$ cm. Having $900 \text{ A} \times \text{turns}$ in one coil, one could expect the amplitude of the first harmonic ≈ 1.2 mT with any desired phase.

Beam deflection Again, the basic parameters were chosen for the extraction of 60 MeV protons. The existing system constraints should be obeyed too. Three electrostatic deflector sections and three magnetic channel sections are used for the beam deflection to the matching point with the cylindrical coordinates $R = 153$ cm and azimuth = 308° , the desired beam spot dimensions being 10×10 mm there. The corresponding radial and axial envelopes were also calculated.

Deflection of 22.5 MeV protons, deuterons and α -particles within the specified energy ranges requires a suitable adjustment of the parameters of all the deflector sections. But, again, their values are less demanding than in case with 60 MeV protons. It was also understood that the extraction of particles of any intermediate energy (in between the above considered extremities) could be easily provided by the proposed device.

As an example, some parameters of the deflector for the case of 60 MeV protons are summarized in the Table.

Parameter	Units	ESD-1	ESD-2	ESD-3	MC-1	MC-2	MC-3
Voltage	kV	55	55	55	-	-	-
Field	kV/cm	110	110	110	-	-	-
Strength	Tesla	-	-	-	-0.183	-0.223	0
Field	kV/cm ²	0	0	-43	-	-	-
Gradient	Tesla/m	-	-	-	0	8	12

The ESD-1 section allows one to use lower voltage in the ESD to provide required beam deflection at the MC-1 section mouth. The preliminary design of the ESD sections was made with the help of the well known RELAX-3D code. In order to reduce the cyclotron magnetic field along the extraction paths and to provide horizontal focusing for compensating for the defocusing effect of the cyclotron fringe field, passive magnetic channel sections MC-1 and MC-2 are employed. Although a relatively low magnet field (≤ 0.3 T) near the MC-3 section allows its active design, the final decision is still to be done. The radial gradients of the sections and the field drops are adjusted by shifting the radial beam position inside them. To this end, channel sections have got rather wide working radial apertures.

Conclusion A new extraction system for the cyclotron AIC-144 is proposed. Computer simulation shows its potentially high efficiency for the specified set of particles and range of their energies. Intensive calculations are still to be continued to prepare a formal Technical Proposal for the device design.

Authors would like to express their gratitude to O.V.Lomakina for her help in prepering this manuscript.

References

- [1] J.Schwabe, J.Starzewski, A.Semkowicz, V.P.Dmitrievski, A.A.Glazov, V.V.Kolga, N.L.Zaplatin. "Automatic Isochronous Cyclotron AIC-144". In: Proceedings of the International Seminar on Isochronous Cyclotron Technique. Krakow, Poland, November 13 - 18, 1978, p.197, IFJ Report N 1069/PL.
- [2] Z.Trejbal, Communications of the JINR 9-10388, Dubna, 1977.

Received by Publishing Department
on December 26, 1996.

Борисов О.Н. и др.

E9-96-492

Исследование возможностей вывода пучка из циклотрона АИЦ-144

Предложена новая система вывода пучка из циклотрона АИЦ-144. Для решения задачи был выбран метод прецессии центров орбит частиц. Отклонение пучка в заданную точку вне ускорителя осуществляется тремя электростатическими и тремя электромагнитными секциями дефлектора. Моделирование на ЭВМ указывает на потенциально высокую эффективность предложенной системы вывода для заданного диапазона частиц и их энергий. В настоящее время ведутся расчеты по определению детальной структуры элементов системы вывода.

Работа выполнена в Лаборатории ядерных проблем ОИЯИ.

Сообщение Объединенного института ядерных исследований. Дубна, 1996

Borisov O.N. et al.

E9-96-492

Feasibility Study of the Beam Extraction from the AIC-144 Cyclotron

A new extraction system for the cyclotron AIC-144 is proposed. A precession of particle orbit centers has been chosen as a solution of the problem. Three electrostatic deflector sections and three magnetic channel sections are used for the beam deflection to the matching point. Computer simulation shows potentially high efficiency of the proposed system for the specified set of particles and range of their energies. Intensive calculations are under way to prepare a detailed design of the device components.

The investigation has been performed at the Laboratory of Nuclear Problems, JINR.

Communication of the Joint Institute for Nuclear Research. Dubna, 1996

Макет Т.Е.Попеко

Подписано в печать 05.02.97

Формат 60 × 90/16. Офсетная печать. Уч.-изд.листов 0,72

Тираж 305. Заказ 49700. Цена 864 р.

Издательский отдел Объединенного института ядерных исследований
Дубна Московской области