

Document received at CERN as
PRIVATE COMMUNICATION
not to be quoted or copied without author's permission

INSTITUTE OF
USSR ACADEMY OF SCIENCES, SIBERIAN DIVISION

CERN LIBRARIES, GENEVA



CM-P00100594

HIGH-LUMINOSITY OPERATION OF THE e^+e^- STORAGE RING VEPP-2M

I.B. Vasserman, I.A. Koop, W.P. Kutovoj, A.P. Lysenko, S.I. Mishnev,
A.N. Skrinskij, G.M. Tumajkin, Yu.M. Shatunov, W.G. Shamovskij.

Proc. All-Union Conference on
Charged Particle Accelerators,
Dubna (1976) 252

Translated at CERN by K. Hübner
(Original: Russian)
Not revised by the Translation Service

(CERN Trans. Int. 79-01)

Geneva
February 1979

High-energy physics experiments with colliding electron-positron beams in the storage ring VEPP-2M¹⁾ have commenced in 1974. In the course of 1975 and 1976, a series of experiments was performed in the range of 2×300 to 2×670 MeV but, particularly, in the region of the ϕ -meson resonance. A considerable part of the time was devoted to the study of radiative polarization, to experiments with polarized beams, and also to the use of synchrotron radiation for applied physics.

During this time a study of beam-beam effects was made and work was done to raise the luminosity²⁾, the most important parameter of the storage ring. Some of the experimental results of these studies are discussed in this paper.

The maximum luminosity has been obtained at 620 MeV, and was $1.5 \times 10^{30} \text{ cm}^{-2} \text{ s}^{-1}$. A comparison of the luminosity of VEPP-2M with other storage rings at 510 MeV (ϕ meson) is given below:

ADONE	VEPP-2	ACO	VEPP-2M
$\sim 1 \times 10^{28}$	2×10^{28}	1×10^{29}	1.2×10^{30}

I. Description of VEPP-2M (Fig. 1)

The injector for electrons and positrons is the storage ring VEPP-2. The average accumulation rate in VEPP-2M is 1.5 mA/min, the maximum positron current is 35 mA, and the maximum electron current is 140 mA. Usually, the beam transfer from one storage ring to the other takes place at the energy of the experiment; the collected particles (in VEPP-2) are added every 10 to 15 minutes. Hence, the experiment runs almost continuously and the average luminosity turns out to be very close to the maximum. The control of the closed orbit and of the beam dimensions as well as the study of the beam dynamics are made by using the synchrotron light transmitted through 14 windows. The measurement of luminosity is done by double bremsstrahlung. The control of the machine and the initial processing of the information (for example, the evaluation of the luminosity or the position of the closed orbit) is performed by a digital computer M-6000.

The storage ring has four experimental insertions with small β_z functions, which are usually set to $\beta_z = 5-6$ cm and $\beta_x = 40-50$ cm.

II. The observed coherent instabilities

The luminosity is limited in the first place by the maximum number of particles which can be accumulated in each beam. Two types of instability were observed with a single bunch.

- i) Longitudinal coherent dipole instability. Such instabilities are usually brought about by the interaction of the beam with elements of the vacuum chamber and, in special cases, with parasitic modes of the accelerating cavities. The instability was suppressed by the retuning of the higher modes in the cavity using the probes foreseen for this purpose.

ii) A vertical coherent instability was observed only for negative chromaticity $E(\partial v/\partial E)$; its threshold was at some milliamperes. It was not observed when a positive chromaticity was introduced.

iii) Coherent coupled oscillations in the radial plane were observed with two beams. The instability manifested itself in a significant increase (3 to 5 times) of the radial dimensions of the beams at currents of 3×3 mA. In this case, the monitors, sensitive to the centre of mass of the bunches, registered a simultaneous excitation of the coherent radial oscillations. It has been possible to excite the instability by short application of an external radial field in a certain current range where the instability did not develop by itself, i.e., in the range between 0.3 and 8 mA if the product of the two currents does not exceed 2 (mA)^2 . The described instability was observed for any possible crossing point of the bunches and did not start from the betatron frequency. This provides evidence that the mechanism of the resonance is not linked to the interaction of the bunches with any short element of the vacuum chamber. The instability was observed only for negative chromaticity, indicating the vital role of single-turn effects for its growth. The instability was suppressed by the introduction of additional damping provided by a sequence of electrodes mounted inside the vacuum chamber.

III. Luminosity. Limits imposed by beam-beam effects.

The luminosity in one crossing point of a colliding beam machine equals

$$L = \frac{k N_1 N_2}{S_{\text{eff}}} f_0 , \quad (1)$$

where N_i is the number of particles per bunch, k is the number of bunches in one beam, S_{eff} is the effective transverse cross-section of the beams in the crossing point, and f_0 is the revolution frequency.

If the transverse dimensions of the beams are equal and if the density distributions are Gaussian with the variances σ_z and σ_r , S_{eff} becomes $4\pi\sigma_z\sigma_r$ and the maximum betatron tune shifts for small amplitude oscillations equal³⁾

$$\Delta\nu_{z,r} = \frac{k N r_e \beta_{z,r}}{\pi\gamma\sigma_{z,r}(\sigma_z + \sigma_r)} . \quad (2)$$

Here it is assumed that

- i) the crossing is head-on,
 - ii) the number of crossing is $2k$,
 - iii) the length of the bunch is smaller than β_z ;
- r_e is the classical electron radius.

If the betatron phase advance between two adjacent crossing points $\mu_0 = \pi\nu/k$ is close to an integer multiple of π , then

$$\Delta\nu = \frac{k}{\pi} \left(\sqrt{1 + \frac{2\pi\Delta\nu_0}{k}} \operatorname{ctg} \mu_0 - 1 \right) \operatorname{tg} \mu_0 \quad (3)$$

holds where $\Delta\nu_0$ is the tune shift, calculated in linear approximation from Eq. (2). From Eq. (3) follows

$$\Delta\nu < \Delta\nu_0$$

for $\operatorname{ctg} \mu_0 \gg 1$. In this case, the betatron tune is just above an integer for two crossing points.

It is usually assumed that the luminosity is limited when the betatron tune-shift reaches a threshold. Experiments are described below which were performed with betatron tunes close to $\nu_z = 3.086$ and $\nu_r = 3.06$. This choice was made because the values are just above an integer and, therefore, are far away from the non-linear resonances of order 3, 4, and 5. Furthermore, the small amplitude working point, displaced by the other beam, does not cross the linear coupling resonance $\nu_z = \nu_r$.

The betatron tune-shift can be obtained from direct measurements of the small-amplitude betatron frequency. Figure 2 illustrates the good agreement of such measurements (experimental points) with the calculation based on Eqs. (1) to (3). The dashed curve shows the corresponding linear approximation (2).

A measurement was performed to determine the maximum tune shift $\Delta\nu_{z(\max)}$ defined as the value where the transverse size of the beam starts to grow. The results obtained for different pairs of crossing points are given below:

Crossing point	β_z (cm)	β_r (cm)	σ_z (mm)	σ_r (mm)	$\Delta\nu_{z(\max)}$
1	5.8	39	0.008	0.25	0.05
2	334	415	0.06	0.73	0.04
3	158	268	0.041	0.58	0.04
4	154	25	0.041	0.21	0.04

It is apparent that $\Delta\nu_{z(\max)}$ almost does not depend on the β -function in the crossing point. The small difference in the point with small β_z has apparently to do with the different aspect of the transverse cross-section of the beams. In the crossing point 1, a low β -section is installed and, consequently, the dependence of the field, generated by the beam, on the vertical coordinate is more linear than in the case of a round beam.

The maximum luminosity was obtained when the initial vertical dimensions of the bunches were reduced by special skew quadrupoles⁴⁾, but a self-adjusting enlargement of the vertical dimensions by a factor 2 to 3 was generated by the beam-beam effect. However, if such size was generated by coupling, the luminosity was smaller (Fig. 3). The dashed curves are extrapolations of the luminosity into the region of large currents; these curves would be valid if the dimensions of the bunches did not increase.

The luminosity at different energies is given below:

E (MeV)	380	510	560	620	670
L (10^{30} cm ⁻² s ⁻¹)	0.25	1.2	1.4	1.5	1

REFERENCES

- 1) G.I. Budker et al., Proc. 4th All-Union Conf. on Charged Particle Accelerators, Vol. II (1975) 313.
- 2) I.B. Vasserman et al., Study of the effects due to electromagnetic interaction of colliding bunches in VEPP-2M, Preprint IYaPh (Siberian Branch, Sov. Akad. Sci.) 76-81, Novosibirsk 1976.
- 3) F. Amman, Internat. Conf. on High-Energy Accel. CERN (1971) 471.
- 4) I.B. Vasserman et al., Contr. to this conf., No. 80.

Figure captions

- Fig. 1 : Schematic layout of VEPP-2M; 1-Injector; 2-synchrotron B-3M;
3-Parabolic lens and converter; 4- accumulation orbit VEPP-2;
5-magnet of storage ring VEPP-2M.
- Fig. 2 : Dependence of the betatron tune-shift on the current of the counter-
rotating beam: $\nu_z = 3.0861$, $\nu_x = 3.0586$, $L_{\text{spec}} = 0.94 \times 10^{28} \text{ cm}^{-2} \text{ s}^{-1} \text{ mA}^{-2}$.
- Fig. 3 : Luminosity versus the product of the currents at 510 MeV for a
reduced vertical beam size (I) and increased vertical beam size (II).

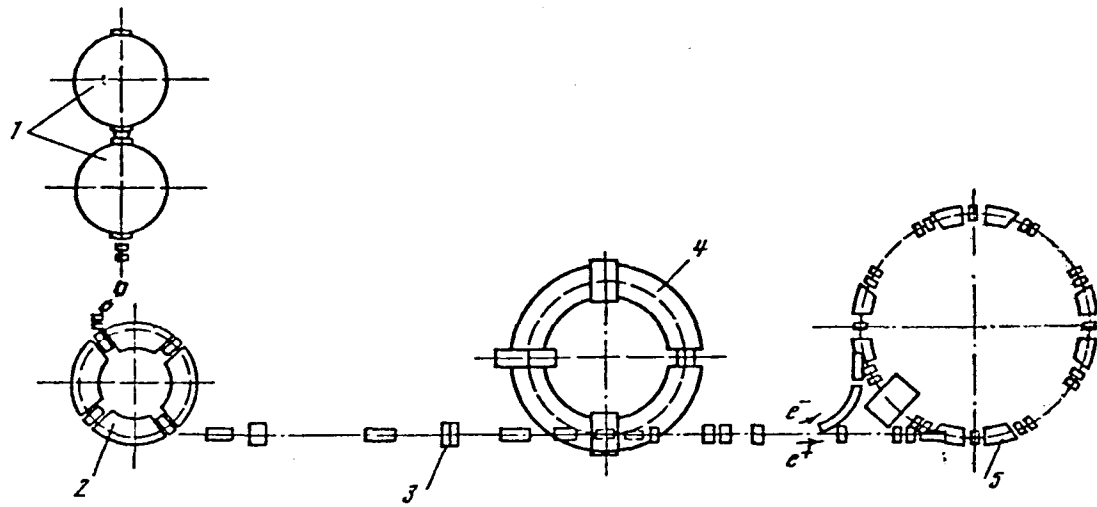

Fig. 1

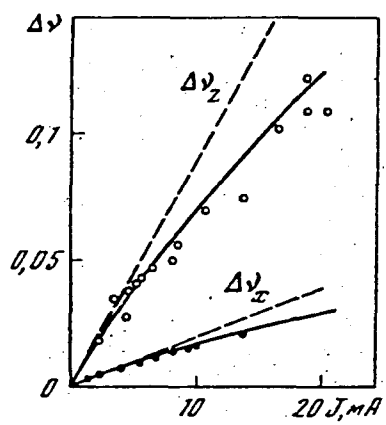

Fig. 2

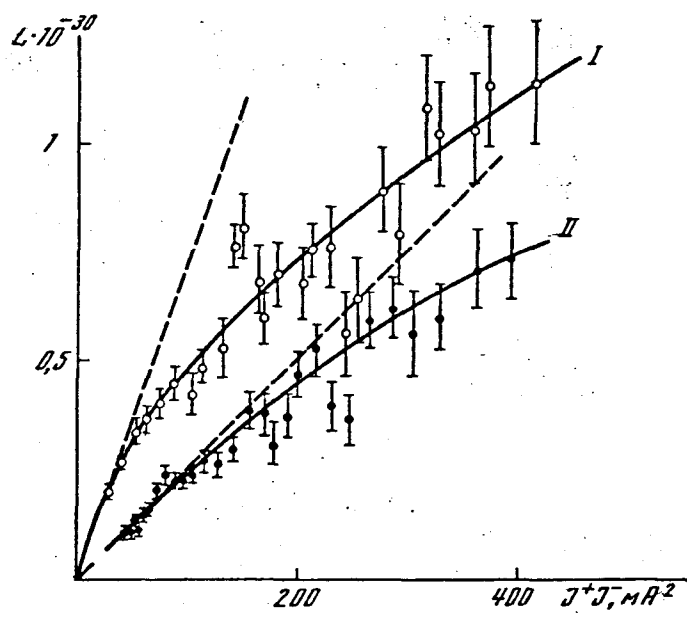

Fig. 3