

EE

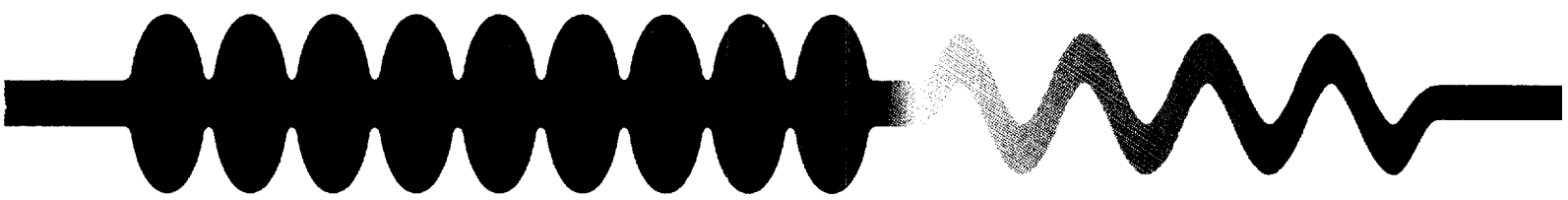

Magnet Design for the TESLA FEL Second Bunch Compression System

I.N. Ivanov, S.I. Kukarnikov, T. Limberg*, M. Marx*,
A. Yu. Molodozhentsev, V. A. Petrov

JINR Dubna, *DESY



Swg646



September 1996, TESLA-FEL 96-12

TESLA FEL Reports are available from:

Deutsches Elektronen-Synchrotron DESY
MHF-SL Group
Katrin Lando
Notkestraße 85
22603 Hamburg
FRG

Phone: (0049/40) 8998 3339
Fax: (0049/40) 8994 4302
e-mail: lando@lando.desy.de or landok@vxdesy.desy.de

Magnet Design for the TESLA FEL Second Bunch Compression System

**I.N.Ivanov , S.I.Kukarnikov, T.Limberg* ,
M.Marx* , A.Yu.Molodozhentsev , V.A.Petrov**

Joint Institute for Nuclear Research, Dubna, 141980 Moscow Region, Russia

** DESY, Notkestrasse 85, 22603 Hamburg, Germany*

Abstract

Magnet design of the C-type dipole magnet for the second bunch compression system is performed. Calculations are made using the POISSON and OPERA-2D programs. Construction of the dipole magnet is designed to get minimum transverse emittance dilution in the TTF second bunch compression system.

The TTF second bunch compression system consists of four identical bending magnets to change the longitudinal rms bunch size from 0.8 mm till 0.25 mm [1].

Main parameters of the dipole magnet for the second bunch compression system should be the following [2] :

- C-type magnet with the aperture gap no less than 2 cm;
- the good field region should be no less than 20 cm in horizontal direction and ± 1 mm in vertical direction;
- dipole magnetic field component should be variable from 2808.712 Gs till 3753.616 Gs for different values of the bending angle which should be between 17÷23 degrees [1];
- length of the bending magnet 50 cm.

Quality of the magnetic field in the working region have to satisfy requirements presented in the report [2]. These requirements are determined by the values of the initial transverse emittance and permissible emittance dilution. The normalized transverse emittance for the TESLA Test Facility [3] is $1\div 2 \pi$ mm.mrad. As is shown [2] the main characteristic of the real bending magnetic field for the bunch compression system is the quadrupole component of the magnetic field to prevent the transverse emittance growth due to the high-order multipole components of the magnetic field.

For the 1π mm.mrad initial normalized emittance and the emittance dilution in the second bunch compression system about 15% the relative

quadrupole component $g = \frac{1}{B_0} \frac{\partial B_y}{\partial x}$ of the magnetic field in the working region should be $4.0 \cdot 10^{-5}$ (1/cm) and the average sextupole component $5.0 \cdot 10^{-4}$ (1/cm²). Then the dipole magnet design is performed to get the field quality in the working region for the emittance dilution less than 15%.

When the aperture of the magnet is much smaller than the length of the magnet and a radius of curvature is bigger than the magnet's length the ends of the magnets constitute only a small fraction of the investigated field seen by a beam and the fact that the fields in the ends are three-dimensional can be ignored. Magnet calculations are made by the POISSON and the OPERA-2D codes.

General views of the dipole magnet for the bunch compression system are shown in **Figures 1,2**. The model of the magnet for magnetic field calculations of is presented in **Figure 3**.

Design of the dipole magnet.

Definition of the main parameters of the magnet.

To simplify installation of the vacuum chamber and the magnetic field probes the C-type dipole magnet should be used. These magnets will be installed vertically along the TTF accelerator. Unfortunately, this type of dipole magnet has some magnetic field gradient to the inner coil for the field in the 0.2+0.4 T. The value of this gradient is constant in the working region for the range of the bending magnet field of the TTF bunch compression system. Magnetic field distribution is a function of permeability of the magnet material. To investigate the influence of the material on the magnetic field quality the different permeability tables are used which are the internal tables of the POISSON and the OPERA programs.

To estimate the "central" field and effective field length of the magnet one can use the well known approximation when the iron is unsaturated

$$B_c \approx \frac{\mu_0 N_p I}{h/2} \quad (1)$$

$$L_{\text{eff}} \approx L_{\text{iron}} + 1.3 \cdot h$$

where h is the dipole gap height [m], $L_{\text{eff}}, L_{\text{iron}}$ are the effective magnetic length and yoke length [m] respectively, $N_p I$ are the required ampere turns per pole [A], B_c [T] is the "central" magnetic field. Typical magnetic field distribution for the C-type dipole magnet in the median plane for a very low carbon steel is presented in **Figure 4** (with the following parameters : the gap height $h=2\text{cm}$ and the coil current density $j=150\text{A}/\text{cm}^2$). This magnetic field distribution in the median plane can be fitted by the function

$$b(x) = B_y(x) / B_0 \approx B_0(1 + g \cdot x + s \cdot x^2) / B_0$$

with $g=1.12655 \cdot 10^{-4} \text{ 1/cm}$ and $s=-2.7814 \cdot 10^{-7} \text{ 1/cm}^2$. From this result one can see that the main problem is connected with optimization of the C-type dipole magnet to minimize the quadrupole component.

The magnetic field quality depends on the dipole magnet gap height as one can see from approximation of the effective magnetic field length (1). **Figure 5** shows the B_y - field distribution for different values of the gap height of the magnet. The current density in the coils of the magnet is chosen so that the magnetic field in the median plane is the same to illustrate the field gradient in the magnet. The solid fat line corresponds to the 2 cm gap height, the solid thin line corresponds to the 3 cm gap

height and the dashed line corresponds to the 4 cm gap height. As one can see from these results the magnetic field gradient depends on the magnet gap height very slightly, but the working region decreases with increasing gap height. To get the demanded working region in the dipole magnet with increasing gap size it is necessary to extend the pole size. Then the value of the gap height should be 2 cm.

Optimization of the dipole magnet.

To decrease the magnetic field gradient (quadrupole component of the field) of the C-type dipole magnet in the working region one can use special trimming the poletips. For this the poles of the magnet should have some converging angle to the external coil to escape the quadrupole component of the field in the working region. **Figure 6** shows the field gradient as a function of the converging angle of the magnet poles. The converging angle is defined as difference of the y-coordinates of the pole edges divided by the pole length. In this case the gap height is about 2 cm and the density of the coil current is 150 A/cm^2 . As one can see from the obtained results, using this way the quadrupole component of the magnetic field in the working region may be decreased significantly till the required values.

Optimization of the pole shapes should be done after measurements of material permeability of the real iron form which the magnets will be made and after the magnet measurements. The correction angle of the magnet poles is a function of the type of the material. Results described above are obtained using the internal permeability table of the POISSON program. **Figure 7** demonstrates the relative magnetic field distribution before (the solid line) and after (the dashed line) correction of the converging angle for another permeability table that is the internal table of the OPERA-

2D program. The magnet configuration is the same as shown in Fig.3, the correction angle is $7.0e-5$ rad.

Technical description of the dipole magnet

Figures 1,2 show the designed dipole magnet. The steel 10 with a carbon content less than 0.13% is planned to use for manufacturing of the magnet yoke (4). The yoke sizes have been optimized to provide the working region about 200 mm, sufficient durability of the yoke under influence of the magnetic field force and to reduce a quadrupole component of the magnetic field in the working region. To minimize the pole width and the power supply the gap height should be as small as possible. The minimum of the gap size is determined by the beam tube dimensions and is 20 mm. The poles (2) should be made so to separate from the yoke of the magnet, to install and swap of the magnet coils (1) and to simplify the pole surface processing. The final surface processing of the magnet poles should be carried out after the magnet measurement to minimize the quadrupole component in the working region.

After this processing the magnetic field accuracy has to be about 0.05% for the flux density 3753.62 Gs. To optimize the edge field the pole-end pieces (3) are installed. The profile of the pole-end pieces should be determined after the magnetic field measurements. The correction coils (5) will be used for the magnetic field tuning. The main parameters of the magnet are collected in **Table 1**.

Conclusion.

The C-type dipole magnet design is performed to minimize the high-order magnetic field component. Influence of the gap height and different permeability of the materials is investigated. Special shim adjusting is calculated to get the required magnetic field quality in the working region. Main parameters of the dipole magnet is determined.

Acknowledgment.

We express deep gratitude to our colleagues at DESY due to which hospitality and support it became possible to perform this investigation. We are grateful to J.Rossbach and S.Vorozhtsov for many useful discussions and fruitful cooperation.

References:

1. T.Limberg, H.Weise, A.Molodozhentsev, V.Petrov The bunch compression system at the TESLA Test Facility FEL, DESY PRINT, September 1995, TESLA-FEL 95-04.
2. I.Ivanov, A.Molodozhentsev, V.Petrov, V.Shevtsov Emittance Dilution in the TESLA FEL Second Bunch Compression System, (will be published in the TESLA-FEL Report).
3. A VUV Free Electron Laser at the TESLA Test Facility at DESY (Conceptual Design Report), DESY PRINT, June 1995, TESLA-FEL 95-03.

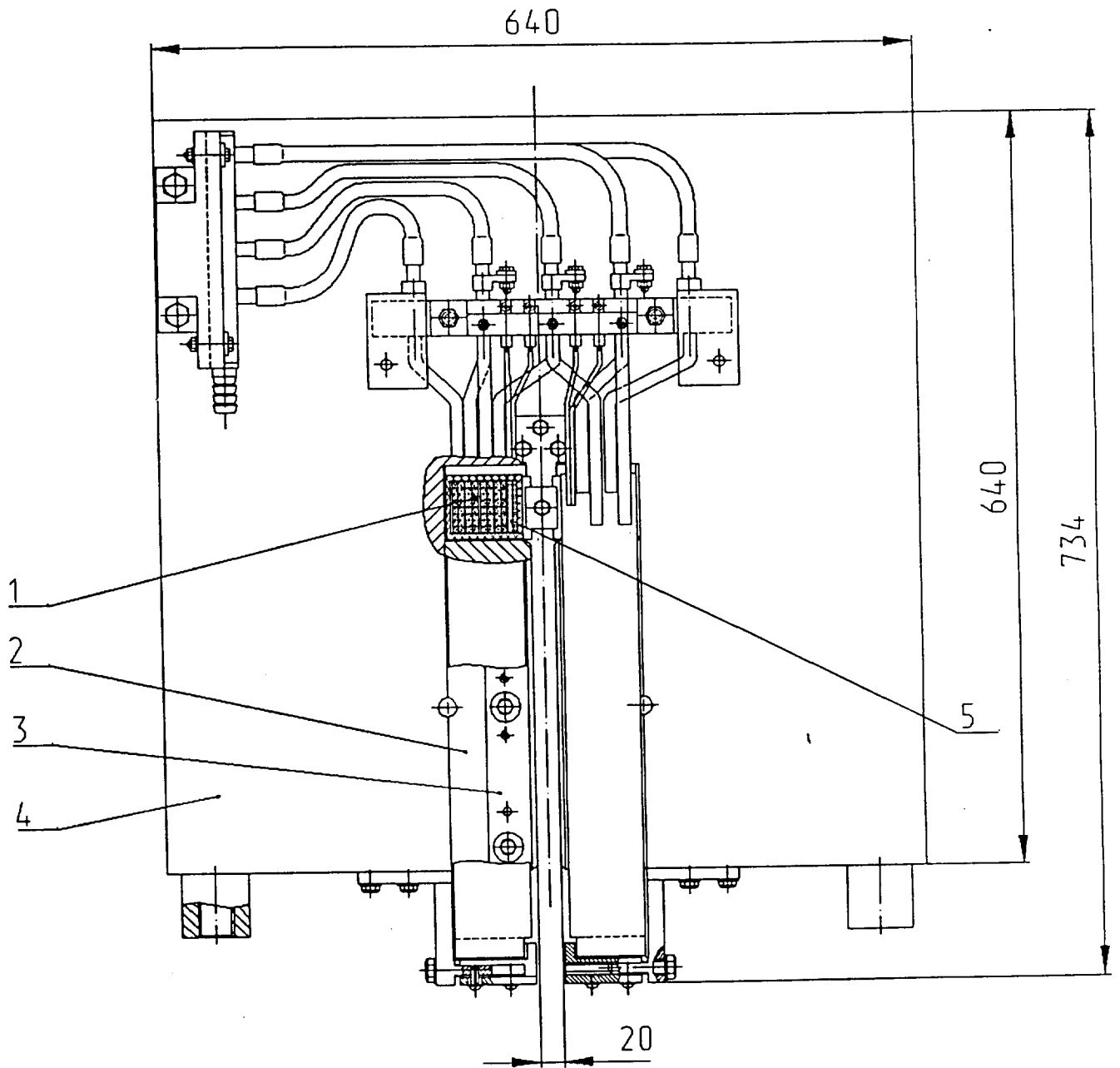

Fig. 1

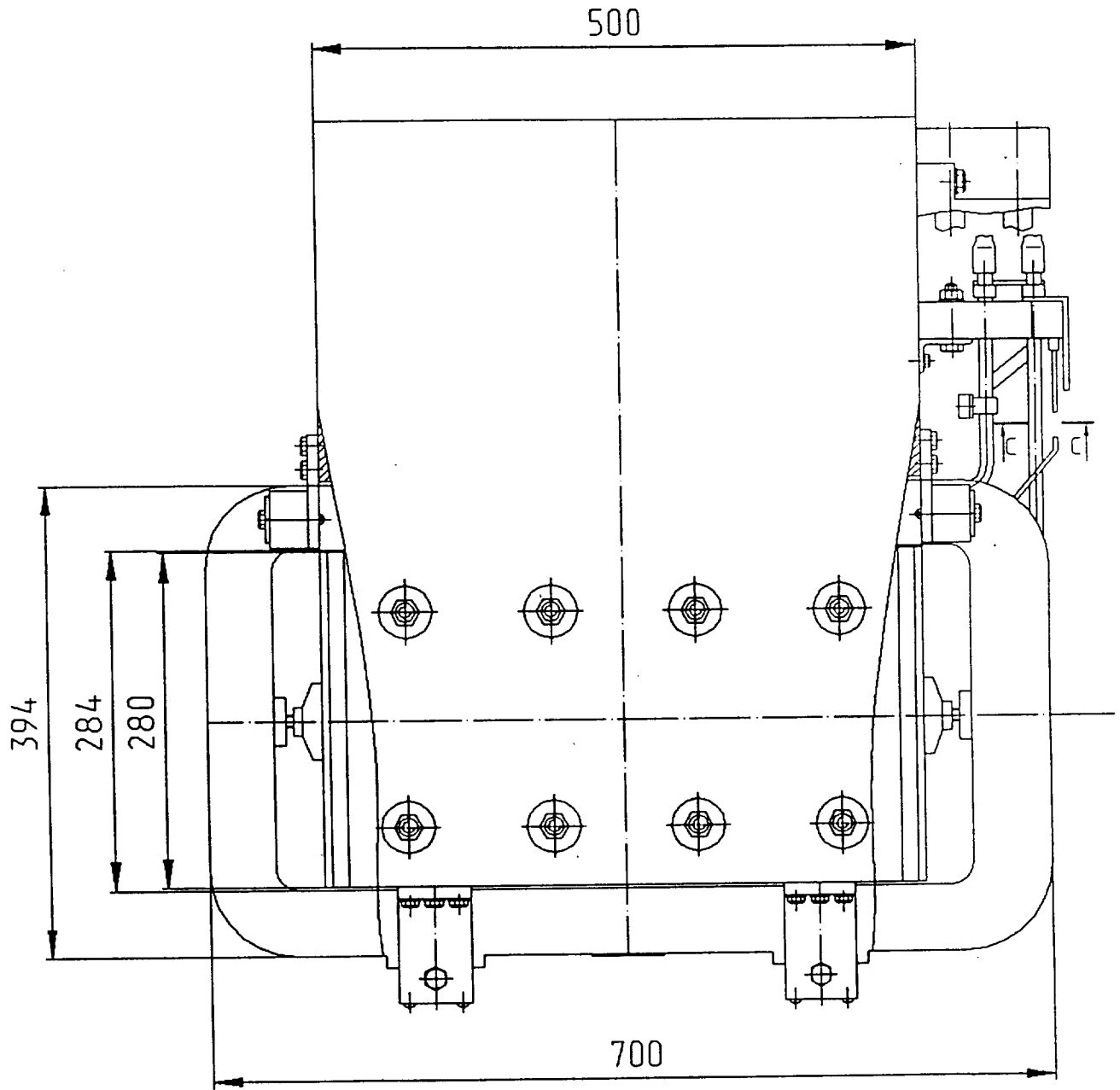

Fig. 2

POISSON: "BASAC" 144MeV, gap=2, order=150.0 A/m^2, Cyclic = 5000

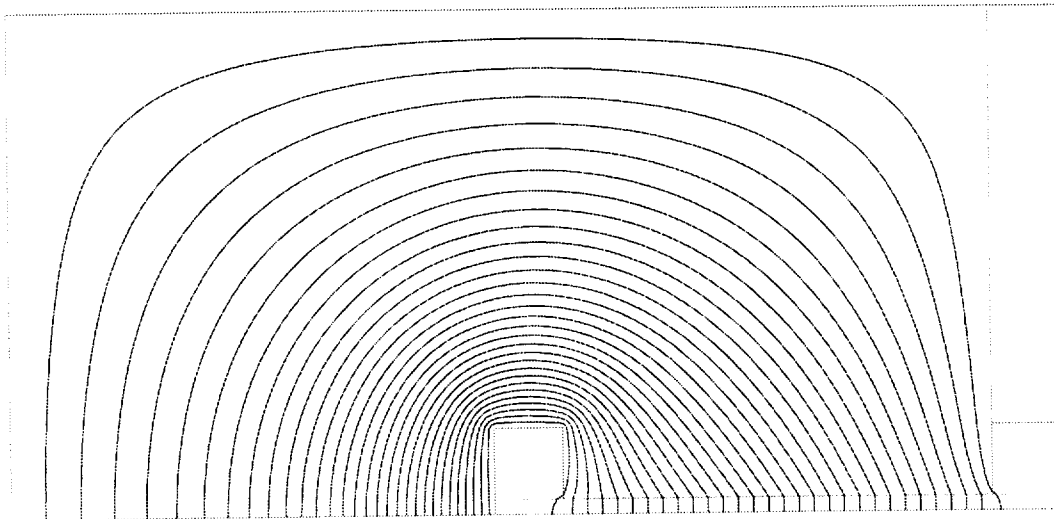

Figure 3:
Computational model of the C-type dipole magnet with the magnetic field lines distribution.

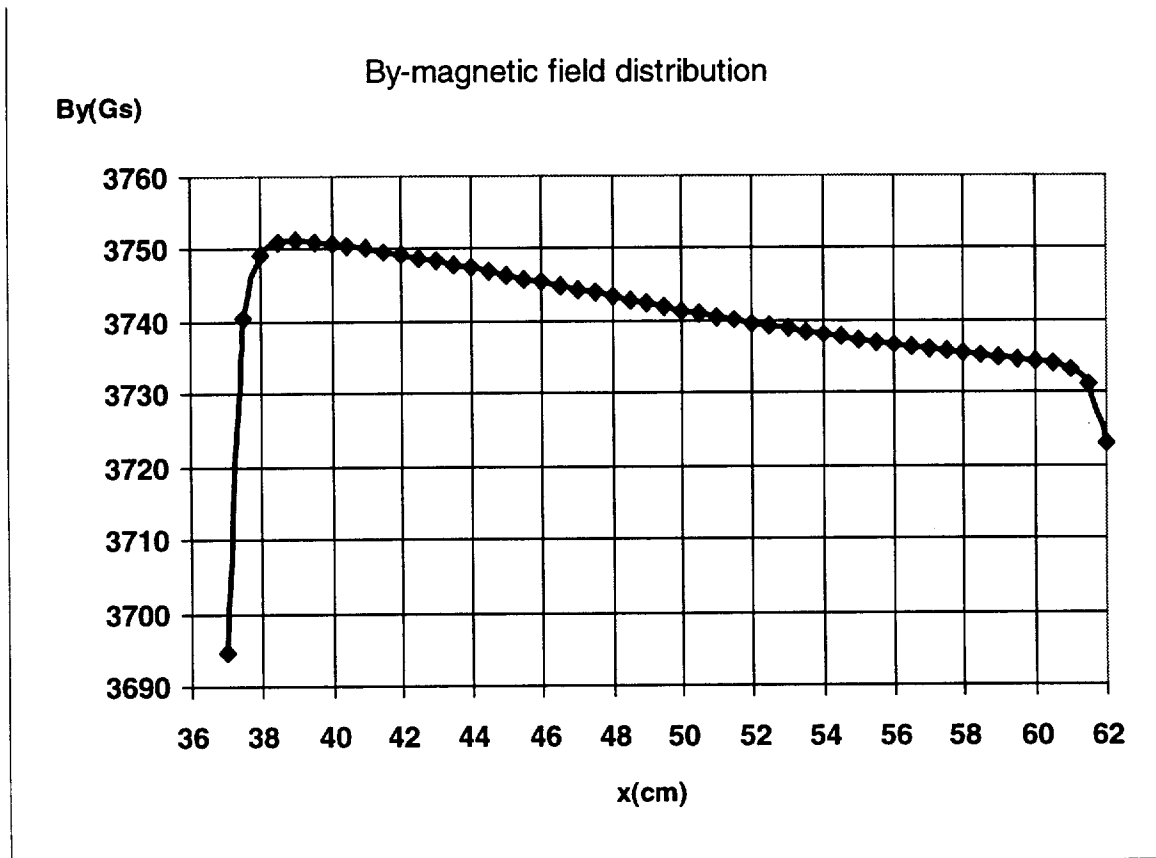

Figure 4:

By-magnetic field distribution in the median plane of the C-type dipole magnet of the TTF second bunch compression system with the 2 cm gap height and the current density in the coil 150 A/cm^2 (the coil cross section: $4.5 \times 4.5 \text{ cm}^2$).

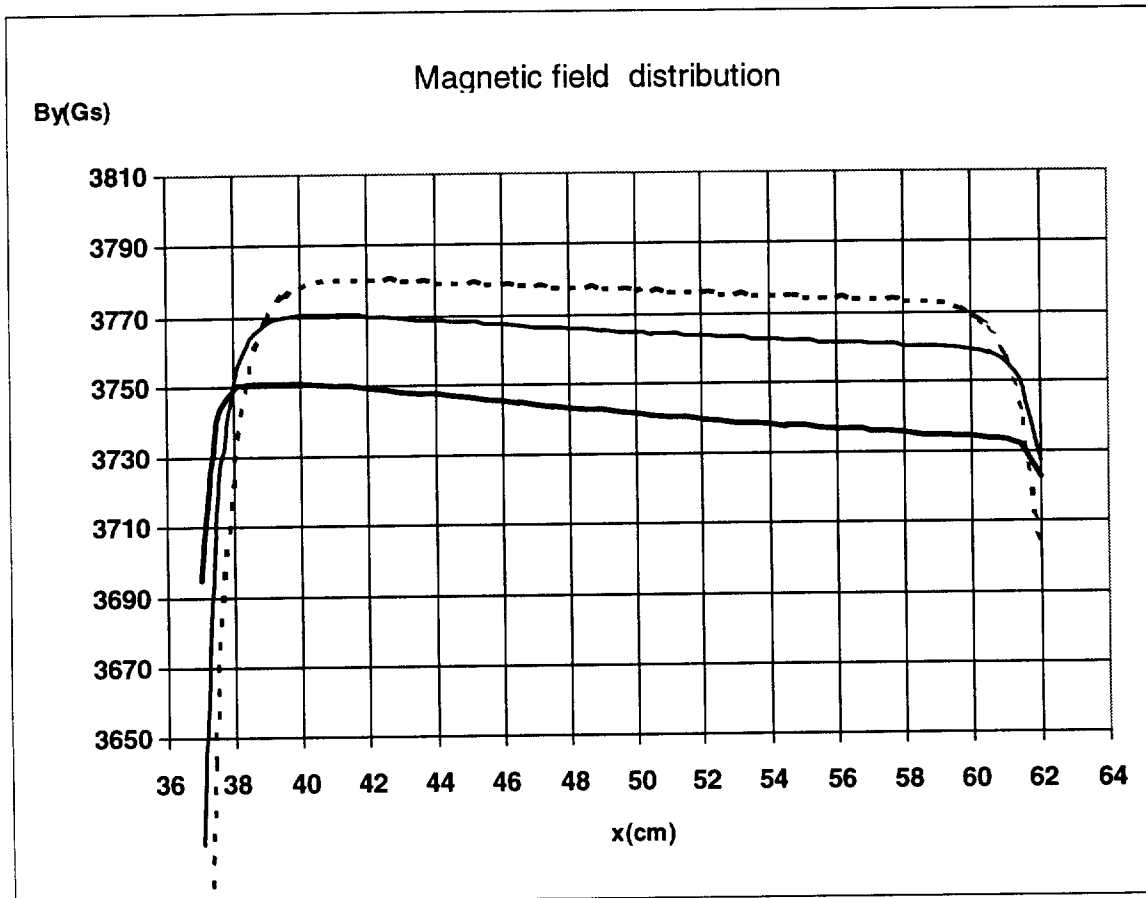

Figure 5:

$B_y(x)$ magnetic field distribution in the median plane of the C-type dipole magnet for different values of the gap height. The current densities in the magnet coils are chosen so that the magnetic field values in the geometrical center of the gap are the same.

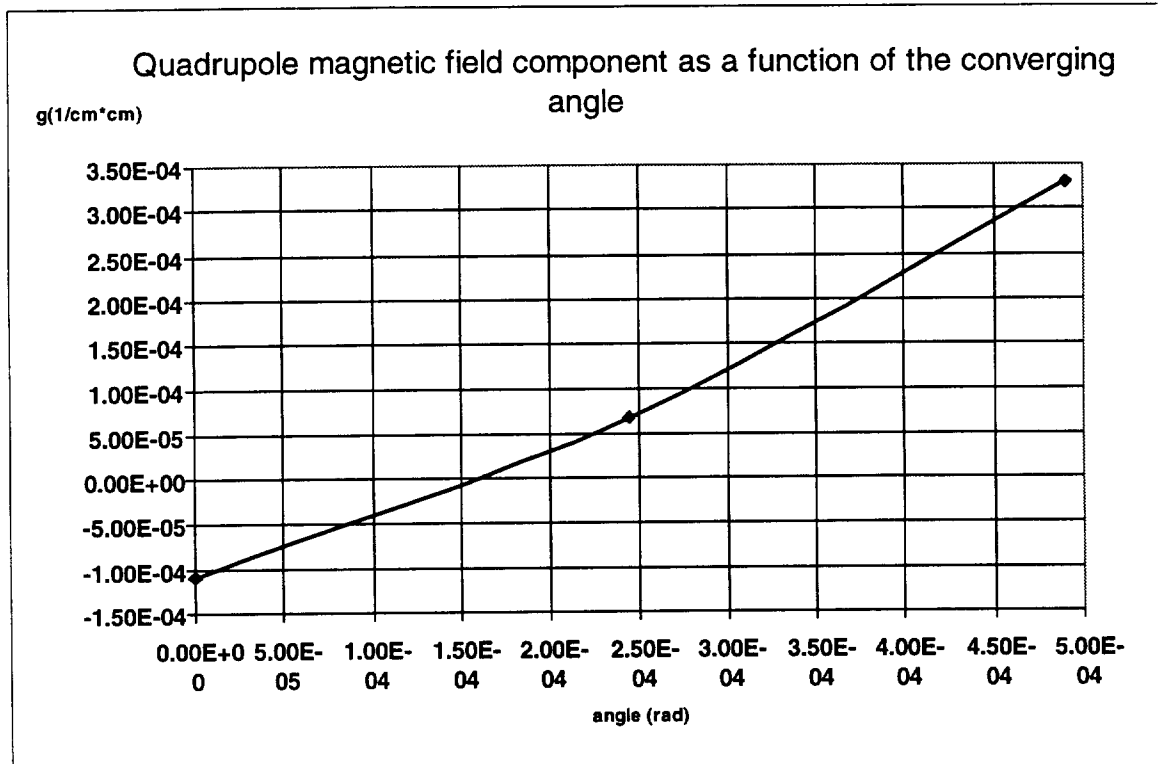

Figure 6:

The quadrupole magnetic field component as a function of the converging angle of the magnet poles. The converging angle is defined as difference of the y- coordinates of the pole edges divided by the pole length.

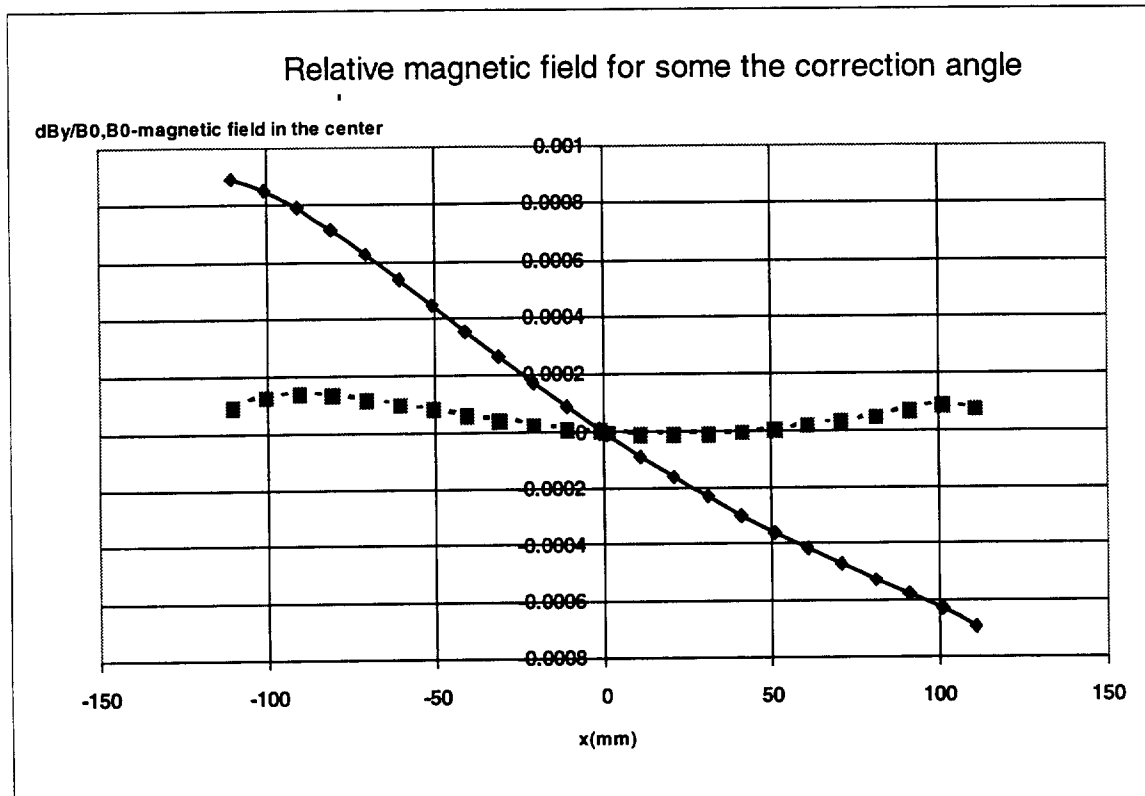

Figure 7:

Fig.7 demonstrates the relative magnetic field distribution before (the solid line) and after (the dashed line) correction of the converging angle of the poles for permeability table that is the internal table of the OPERA-2D program.

Table 1**Main Parameters of the C-type dipole magnet**

Bending angle , degree	17 ÷ 23
Flux density , Gs	2808.7 ÷ 3753.6
Gap height , mm	20
Working region , mm	220
Quadrupole component , 1/cm	< 2.5e-05
Sextupole component, 1/cm ²	2.0e-06
Supply current , A	190
Source density , A/mm ²	2.4
Supply voltage , Volts	2.7
Number of turns	32
Wire material	copper
Wire cross section area , mm ²	80.6
Number of turns of correction coils	72
Flux density at the 4.3 A supply current , Gs	200
Magnet width , mm	640
Magnet height , mm	640
Pole length , mm	500
Pole width , mm	280
Magnet mass , kg	1800

