

LL

JET-P(96)13

B Macklin et al

Developments towards Remote
Metrology for Component
Alignment under Conditions of
Restricted Access in
JET's Toroidal Vacuum Vessel

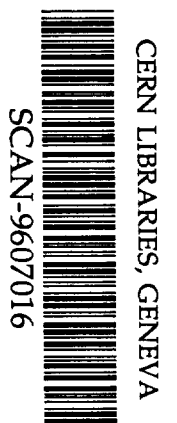

JOINT EUROPEAN TORUS

JET

This document is intended for publication in the open literature. It is made available on the understanding that it may not be further circulated and extracts or references may not be published prior to publication of the original, without the consent of the Publications Officer, JET Joint Undertaking, Abingdon, Oxon, OX14 3EA, UK.

Enquiries about Copyright and reproduction should be addressed to the Publications Officer, JET Joint Undertaking, Abingdon, Oxon, OX14 3EA, UK.

Developments towards Remote Metrology for Component Alignment under Conditions of Restricted Access in JET's Toroidal Vacuum Vessel

B Macklin, R Brade, G Celentano, J Tait, E van Lente.

JET Joint Undertaking, Abingdon, Oxfordshire, OX14 3EA, UK.

Preprint of a paper to be submitted for application in
International Archives for Photogrammetry and Remote Sensing

May 1996

ABSTRACT

The JET Joint Undertaking was established in 1978 to construct and operate the Joint European Torus (JET) at Culham in the U.K. JET is the world's largest fusion experiment funded and staffed by the EU member states and Switzerland. Its aim is to prove the scientific feasibility of nuclear fusion as a new energy source.

A major component of the JET machine is a large (200m³) toroidal vacuum vessel whose interior is subject to regular modifications and upgrades. The installed equipment has increased in quantity and complexity while the working environment has deteriorated due to increasing radiation levels and the presence of highly toxic beryllium dust. Progress in plasma physics has led to a requirement for much improved alignment accuracy. This paper describes the evolution of the survey and alignment methods used to accommodate the requirements of increased accuracy and complexity and the wearing of full pressurised suits. The ultimate aim is to carry out checking surveys remotely to an acceptable tolerance.

1. INTRODUCTION

1.1 Nuclear Fusion

Nuclear fusion is the energy producing process which takes place in the sun and stars. Energy is released when the nuclei of light elements fuse together to form heavier ones. The easiest fusion reaction to achieve is between the two heavy isotopes of hydrogen (tritium and deuterium). In a fusion reactor the heat generated from this reaction could be extracted to raise steam for conventional electricity generation. The aim of the JET project is to prove the scientific feasibility of fusion. Nuclear fusion is likely to be Europe's best long-term solution to the energy problem. The JET machine is used for advanced research into plasma confinements, boundary interactions, heating and fuelling of plasma. To monitor these experiments there are numerous diagnostic instruments and systems.

2. THE JET MACHINE

2.1 The JET Machine

The JET device (figure 1) consists of a vacuum vessel in which the plasma is created and confined, the magnetic field components (the coils) which position the plasma and the mechanical structure which encloses the central components of the machine and resists the large forces produced due to interactions between the currents and the magnetic fields.

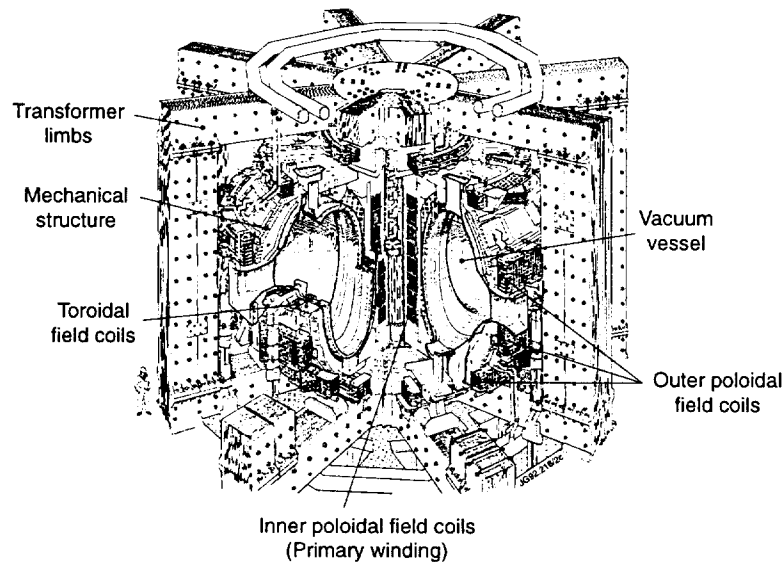

Figure 1. Diagram of the JET Machine

The double walled toroidal vacuum vessel is suspended within the cast iron mechanical structure shell. This shell is mounted within the large transformer limbs for which the plasma forms the secondary winding. Between the mechanical shell and the vacuum vessel there are 32 large D-shaped toroidal field coils. The vacuum vessel, which is manufactured from inconel, has major and minor radii of 2960 and 1315mm, with an internal height of 4300mm. It has a volume of 200m³, weighs 108 tonnes and is designed to operate at a vacuum of 10⁻¹⁰ mbar. JET requires 700MW of power for each pulse of up to one minute. This is supplied by the National Grid and two large flywheel generators.

JET uses the Tokamak magnetic field configuration to maintain isolation between the hot plasma (up to 300 million degrees celcius) and the vessel walls. The primary winding of the transformer, situated at the centre of the machine, is used to induce the plasma current. The toroidal plasma acts as the single turn secondary winding of the transformer. The toroidal stabilizing field is generated by the 32 toroidal D-shaped coils. Around the outside of the mechanical structure but within the confines of the transformer limbs are six poloidal field coils which are used for shaping and positioning the plasma.

2.2 In-vessel Installation

A key requirement of in-vessel installations is usually alignment. There are a number of reasons for this ranging from the need to have components carefully aligned with respect to the magnetic field to ensure uniform thermal loading, to knowing where diagnostic sensors are to allow interpretation of data which is often used to control plasma parameters. During future shutdowns at JET, radiation levels due to neutron activation will restrict durations of manned in-vessel access to the point where work would no longer be possible. In fact, all installation work is planned to be carried out remotely using JET's remote articulated boom (figure 2).

Precision surveys will also have to be carried out remotely. This has been the subject of research at JET for some time, with many different systems being investigated, e.g. optical, photogrammetry, laser scanning. Videogrammetry was used at the end of the recently completed major shutdown to provide an 'as-built' record of major in-vessel components and a datum base for dimensional integration into the future. Suitability of videogrammetry for use in remote handling shutdowns is being assessed. Targetting of components is a major problem, but at present a targetless form of videogrammetry is being considered for collecting 'as-built' information to an accuracy of $\pm 1-2\text{mm}$, with laser scanning techniques for more accurate local measurements, e.g. steps and gaps between tiles. The techniques developed at JET over the last three years are described along with steps to ensure that similar control will be exercised in the future when installation work is carried out remotely.

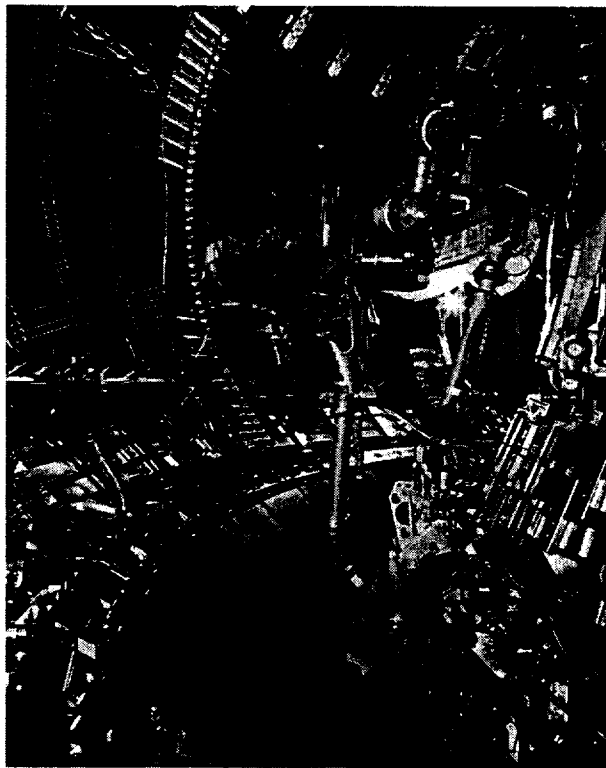

Figure 2. JET's Remote Handling Articulated Boom being used to install tiles inside the vacuum vessel.

3. THE PUMPED DIVERTOR PROGRAMME

JET's scientific programme for the future is largely based on a series of Pumped Divertors with a campaign of experiments planned to study control of impurities in the plasma. The first or MKI Divertor was installed in 1992, the MKII during 1995/96 with the fully remote installation of MKIIGB (Gasbox) planned for 1997. The MKII Divertor concept is based on two major components - a fully machined and very precise *support structure* on which different configurations of *plasma facing tiles* can be mounted. Future changes such as the MKIIGB configuration will be implemented by changing only the tile assemblies remotely.

3.1 The MKI Divertor Installation

In 1992 a major rebuild of the JET machine was carried out in order to install the MKI Pumped Divertor. Due to the high thermal loads envisaged during operation, accurate positioning of the plasma facing components to the magnetic centre of the machine was a major requirement. Typically alignment to better than $\pm 2\text{mm}$ was required with steps between tiles on a component being controlled to $\pm 0.25\text{mm}$. In some cases a set of components was required to be concentric while also lying within a narrow band defined by the position of some other components. Clearly, a measuring system accurate to better than $\pm 0.5\text{mm}$ was required.

Prior to 1992 component surveys and alignment checks at JET depended on some combination of conventional metrology equipment and jigs, usually based on a precise survey ring. For the installation of the MKI Divertor (Macklin, 1994) a sophisticated survey ring system was designed and built. This was used successfully for the installation of the lower vessel components. However, it soon became apparent that to achieve the required accuracy for the upper vessel components would require a system so complex and cumbersome that it would not be compatible with other installation tasks, therefore having a serious adverse effect on the shutdown schedule which was critical.

3.2 Computer Aided Theodolite Systems

Various alternative systems were investigated resulting in the purchase of Leica's ECDS3, an optical 3-D non-contact measuring system now known at JET as the CAT (Computer Aided Theodolite) system. ECDS3 uses two electronic theodolites to measure the horizontal and vertical angles to a network of targets and a calibrated scale bar. The resulting set of simultaneous equations is solved using a mathematical technique known as bundling.

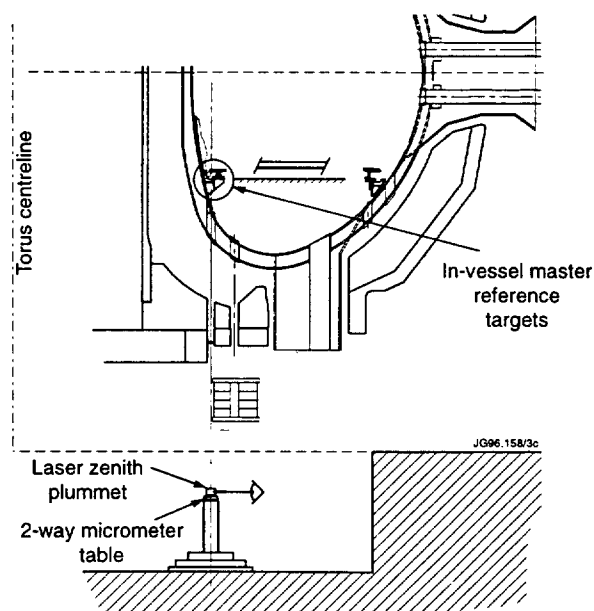

Figure 3. Transferring ex-vessel reference to establish in-vessel datum system.

3.3 In-vessel Datum System

An in-vessel datum system was designed for use with the CAT system and to be compatible with future installations. Special targets were developed and their optimum positions in the vacuum vessel were optimised on JET's CAD system. This was carried out in parallel with a major hands-on system development programme which included building and surveying a simple full size mock-up of the vacuum vessel. This was used to develop, prove and qualify the accuracy of the optimum multiple set-up survey technique needed to combat the difficult geometry of the JET vacuum vessel. After optimisation, the mock-up was used for intensive operator training in a successful bid to cut survey times. Trials were also carried out to develop the adjusting and measuring technique required for each set of components. After surveying the in-vessel datum system, CAT software was used to transform target coordinates into the machine datum system, which has its origin at the machine centre, by referring to master in-vessel targets which could also be sighted from ex-vessel as shown in figure 3.

3.4 Preparations for In-vessel Use

Wall mounted vibration-free theodolite supports were developed. The colour laptop computer was built into a special aluminium case along with the necessary interface modules. In addition, the computer was fitted with an integral modem which allowed fast downloading of data at the end of every shift to a dedicated computer ex-vessel. Transfer of data by floppy disc was complicated by the possibility of beryllium and tritium contamination. Use of optical instruments in-vessel (figure 4) was hampered by the necessity to wear full pressurised suits to protect against the hazard of air-borne beryllium dust. Special suits with optially clear visors were developed and used successfully during the MKII Divertor installation. Fortunately full suits were not required during the majority of the MKI Divertor installation.

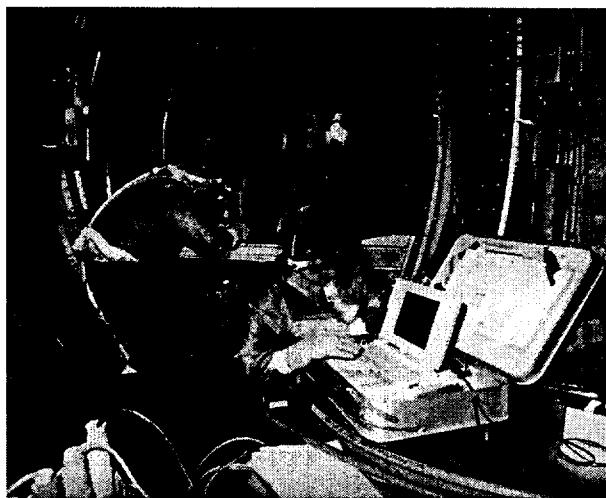

Figure 4. Surveying in-vessel with the CAT system during the MKII Divertor installation.

3.5 The MKII Divertor Support Structure Manufacture and Installation

The main components of the support structure (figure 5) are an inner and outer ring mounted on a baseplate. The outer diameter of the assembly is 6.2m, the inner diameter 4.5m, height 0.5m and weight 7 tonnes. The structure breaks down into 24 sub-assemblies or modules to allow insertion and assembly in the vessel (Celentano, 1995). The modules were connected using 32 precision dowels and bolts at each joint. It was clear from an early stage that the precise assembly of the components of the structure was fundamental to the achievement on installation of the conflicting tight tolerances on position, roundness and concentricity to machine centre. Consequently the use of the CAT was integrated into the design, manufacture and assembly (Macklin, 1995) as well as the installation of the structure.

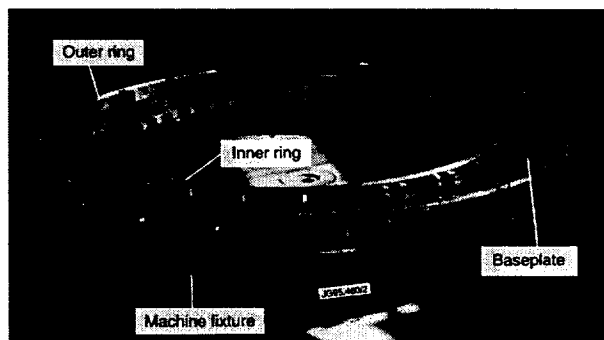

Figure 5. The components of the MKII Divertor structure.

The CAT system was used to check the large fixture used for the final machining and assembly sequences at the manufacturers (figure 6). With 24 joints in the structure it had to be assumed that the structure would build to a slightly different shape each time it was dismantled and reassembled (a total of 3 times). This led to a concept of 'as-built' co-ordinates and a 'best-fit' approach where the actual dimensions are allowed to float into their best average fit to theoretical dimensions. The comparison between the three builds is illustrated in figure 7.



Figure 6. Using the CAT system to survey the MKII Divertor

4. ACCURACY

Survey systems such as ECDS3 can initially pose a problem for mechanical engineers who may be used to conventional metrology equipment where an accuracy can be quoted and repeatability checked. The accuracy of the CAT system depends largely on geometry, redundancy of sightings taken and the operators understanding of how these two factors affect the data.

In-vessel, two complete surveys of the datum system were carried out by different teams working on opposite shifts. Results were checked in detail and found to agree to better than 0.2mm. Checks on the accuracy of the system carried out in-vessel by surveying accurately machined details of the survey ring suggest a measuring accuracy of 0.05mm/metre.

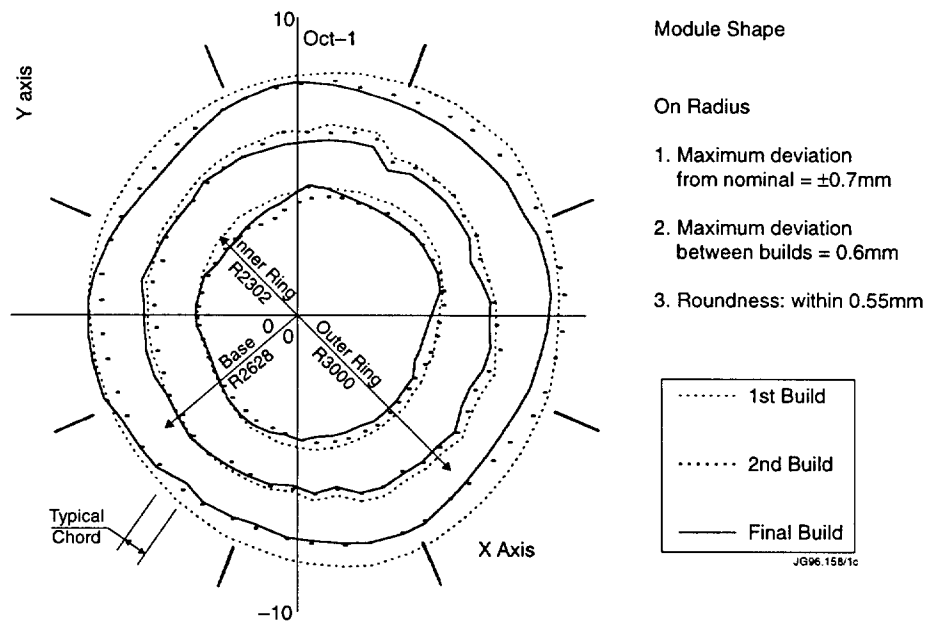

Figure 7. Graphical comparison of the three builds of the MKII Divertor structure.

Consider the three graphs of survey results shown in figure 7 and ignore the problem of the structure building to a different shape and the effect of temperature variation between surveys. Approximately 150 chord lengths were compared between the first and second surveys. The chord lengths were unaffected by the effects mentioned above. Each chord length was derived from two survey measurements so each comparison gave the cumulative error of four survey readings. The results showed that 80% of the chords repeated with an error of less than 0.1mm. The remaining 20% showed an error of less than 0.3mm. This gave a high level of confidence that the accuracy of the surveys was generally better than $\pm 0.1\text{mm}$.

5. REQUIREMENTS FOR REMOTE SURVEYS

5.1 Basis for Future Experiments

The MKII Divertor structure will be the basis for the MKIIGB Divertor and as the structure has already been accurately manufactured and installed in-vessel it would appear that no more surveying should be required. However it was considered prudent to plan to confirm the integrity of the structure after the removal of the MKII tile system as there is a risk that any one of a number of highly stressed components may have failed. As none of these components are directly visible, even with manned access, surveying the structure to confirm its shape and position is now considered to be essential. In addition a precision survey is the only way of confirming that all of the new tile assemblies, which will have been installed remotely, has been installed correctly and is fully seated.

5.2 Survey System Selection

When the need for remote surveying inside the vacuum vessel was identified, a study of systems available on the market place was undertaken. The purpose of the study was to identify which systems could be used (or adapted for use) remotely. A further major requirement was that the system should be suitable for use without targets. Many potentially suitable systems were found, many of which are based on some form of laser scanning. However these were still at the prototype stage and were ruled out because of JET's policy of using only proven, commercially available systems.

5.3 Videogrammetry

Finally it was decided that the most suitable commercially available system was videogrammetry. This was a technique with which JET already had some experience, albeit in the form of convergent photogrammetry. Videogrammetry is based on the same principles but uses a CCD camera instead of the film-based camera used in photogrammetry. The slight potential decrease in accuracy does not pose a difficulty in the context of JET's planned use of the system. JET's experience with optical systems based on the triangulation principle meant that a good assessment of the suitability of videogrammetry could be made. At JET Inspection personnel are now highly proficient users of the ECDS and other software. Virtually all report writing and survey data acquisition has been computerised, resulting in significant labour savings. A data control protocol has been developed, including techniques for data manipulation e.g. for determination of planes, preparation of machining input data. Data from several additional computerised systems recently acquired at JET e.g. digital level, single theodolite measuring station can be combined. Videogrammetry was seen as the natural evolution of the systems and techniques already employed at JET and has the advantage of being suitable for use in conjunction with these systems on other increasingly important ex-vessel applications.

Although videogrammetry is not a targetless system, a contract survey company (ESIC), which has previously carried out photogrammetry surveys at JET, have developed software which allows features e.g. holes, corners, edges of components to be selected with the cursor on screen. Provided the same feature can be seen in two or more pictures the videogrammetry bundle software can be used to determine the coordinates of the feature to $\pm 1-2\text{mm}$. Trials carried out in JET's training facility confirmed this.

In addition one laser scanning system was selected for testing as it was felt that it might have applications for specific types of survey e.g. small local surveys to check steps and gaps between adjacent tiles with a high level of precision.

5.4 Targetting the In-vessel Datum System

To ensure that the coordinates determined during a survey are in the coordinate system defined by the in-vessel datum system, the datum system targets must also be included in the survey. This poses a major problem. Standard retroflective videogrammetry targets which are usually fitted to the vacuum vessel datum system are not compatible with plasma operation and therefore must be removed from the vessel at the end of every shutdown. As the requirement for a remote survey is due to radiation levels preventing extended manned access it is clear that targets would have to be fitted remotely or that targets compatible with machine operation would have to be designed. The former option was ruled out on the basis that the time to fit 180 targets would be excessive. The principle of using hole targets was tested during videogrammetry trials in JET's training facility, where it was found that given good lighting and good contrast between the hole and its surroundings reasonable accuracy was achievable. With guidance from ESIC a plasma compatible target (figure 8) was developed. This consisted of a circular boss with an accurately machined 10mm hole. The inside of the hole was plasma sprayed with a uniform coating of (black) chromium oxide to maximise the contrast which will facilitate manual selection of the target using ESIC's software.

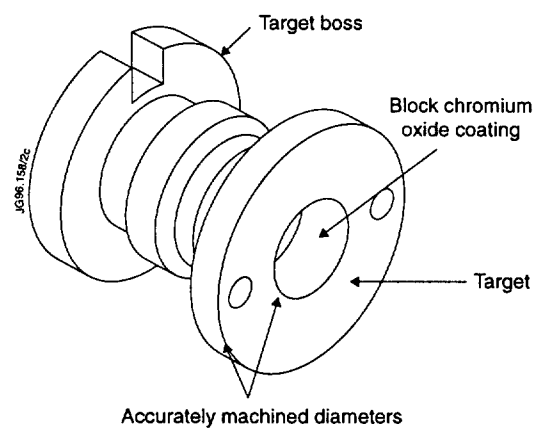

Figure 8. Plasma compatible target.

5.5 Trial Videogrammetry Survey

At the end of JET's recent shutdown for the installation of the MKII Divertor a videogrammetry survey was carried out. The object of this survey was to record the status of the in-vessel datum system (fitted with retro-reflective targets), to record the as-built status of the main in-vessel components from the resulting digital model and therefore to prove the feasibility of using videogrammetry in future remote interventions. One of the main difficulties with this survey was in determining lighting parameters which were suitable for the conflicting requirements of seeing reflective targets and actual components. However the compromise reached allowed good visibility of all reflective targets and acceptable visibility of components (figure 9) in most positions so that the position of untargetted components could be determined to better than $\pm 2\text{mm}$.

6. INTERFACING VIDEOGRAMMETRY WITH THE REMOTE ARTICULATED BOOM

6.1 Development of Survey Technique

The final stage in automating the survey process involves JET's remote articulated boom on which the six million pixel camera will be mounted. An intensive period of survey trials is envisaged over the coming months to determine the optimum survey technique in terms of the intersection geometry i.e. camera positions which ensure satisfactory intersections between shots and sufficient visibility of components. Lighting will be studied in detail. Accuracy will be monitored by comparing videogrammetry surveys with CAT surveys. The aim will be to achieve similar levels of accuracy ($\pm 2\text{mm}$) with the plasma-compatible targets fitted to the datum system in place of the previously used retroreflective targets. The most suitable natural features of components for selection will be determined. When this is determined trials in conjunction with the boom will be undertaken to develop 'teach and repeat' files which will allow the boom to go automatically to the camera positions required.

The boom will be required also to position the scale bars necessary for determining the scale of the survey. Volume point bars will also be required. These are bars fitted with retro-reflective targets. These are required to ensure that the minimum density of targets required for the calculation is achieved and to ensure that an accurate overlap between photographs is achieved. These are essential and a design of 'bar' which facilitates ease of handling and positioning with the boom as well as maximising the density of targets will be fundamental to the success and accuracy of the survey. Optimum position for these bars will be determined as part of the survey technique development mentioned previously. Boom handling of the bars will have to be studied and developed along with a method for positioning the bars and ensuring stability during the course of the survey. The time required to perform these operations will be a major factor in determining the most suitable methods.

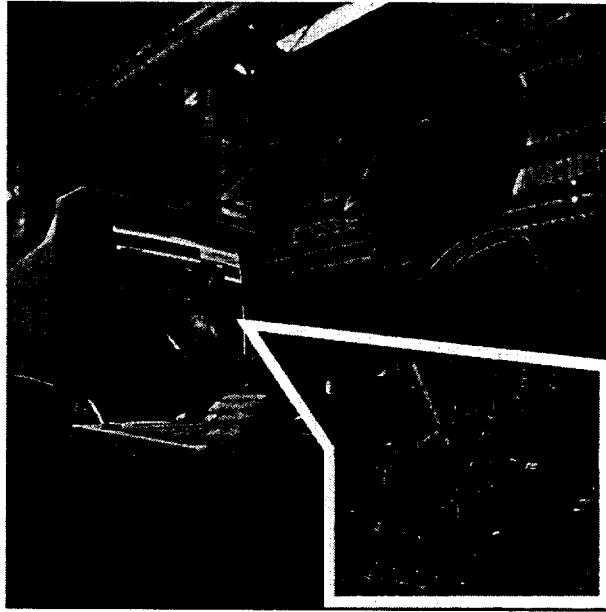

Figure 9. Working with the digital model of in-vessel components resulting from videogrammetry survey.

6.2 Hardware and Interfaces

Downloading of data from the camera will be studied carefully. This is restricted by the need to use only existing wiring on the boom. The tight space envelop prevents the addition of additional wiring. The latest development of Leica's V-STARS system is expected to help overcome this difficulty as it incorporates a 486 chip in the camera which carries out partial processing of the data with the result that a single six-core network cable will handle all electrical interfaces to the camera. This can be accommodated within the boom's existing loom which caters for the addition of specialist tools.

7. STEP AND GAP MEASUREMENTS

After completion of the tile installation on the MKII Divertor structure the need to check the critical steps and gaps between certain tiles was identified. Conventional mechanical means of carrying out this check were complicated by the fact that any contact with delicate tile edges would almost certainly damage them. A laser scanning survey was carried out using a tool originally developed for remote inspection of welding inside pipes. This non-contact tool scanned the gap between adjacent tiles (figure 10). The required dimensions could then be determined by selecting the appropriate points of the cross section with a cursor on a computer screen. Results of the survey allowed engineers to confirm that steps and gaps were within tolerance and that difficult and expensive remedial work was not necessary. Survey time to measure the step and gap at twelve locations was about twenty minutes with another twenty minutes required for interpretation of results. Accuracy achieved was of the order of ± 0.1 mm. Superior accuracy can be achieved with a tool which scans in two orthogonal directions to take account of the complex surface geometry of the tiles. As steps between adjacent tiles are critical on most components, with gradual undulations

being less critical, this system will be essential during a remote tile installation. It will be used to determine whether adjacent tile assemblies are fitted correctly and, in the event that difficulties are encountered, will be used to quantify the problem and allow a solution to be developed with certainty. The parameters for a scanner to be made for JET are being prepared. Remote handling of the scanner will be developed but again the major difficulty foreseen is that of the electrical interfaces with the articulated boom.

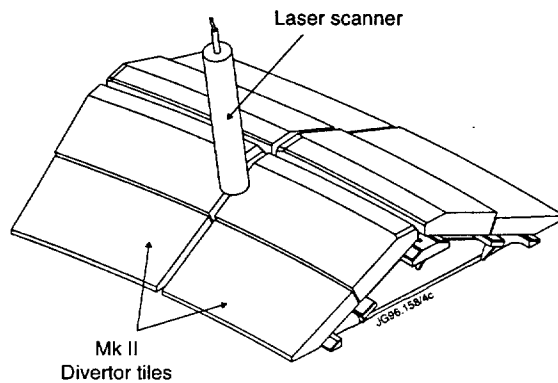

Figure 10. Illustration of laser scanner survey of tile step and gap

8. CONCLUSION

Plasma physics requirements have led to the need for improved installation and alignment accuracy. At JET this meant a transition from local jig based to non-contact optical techniques operated within a single coordinate datum system resulting in a tenfold improvement in alignment accuracy. Special survey methods and data handling techniques were developed to suit JET's particular geometry and difficult working conditions. Techniques developed are now being increasingly applied throughout other manufacturing contracts. In-vessel survey techniques and equipment are now being used extensively ex-vessel for positioning equipment which has in-vessel interfaces and for providing 'as-built' information required for CAD configuration control models.

The evolution of surveying will continue at JET with the planned remote application of targetless videogrammetry with the selective application of laser scanning techniques during the first full remote handling intervention at JET.

9. REFERENCES

Manufacturing and Installation of JET MKII Divertor Support Structure. G Celentano et al., 16th Symposium on Fusion Engineering, Champaign 1995.

Alignment Systems for Pumped Divertor Installation at JET. B Macklin et al., 18th Symposium on Fusion Technology, Karlsruhe 1994.

Application of 'Best-Fit' Survey Techniques Throughout Design, Manufacturing and Installation of the MKII Divertor at JET. B Macklin et al., 16th Symposium on Fusion Engineering, Champaign 1995

Leica AG, Photogrammetry and Metrology, CH-5035, Unterendfelden, Switzerland.

ESIC Reseau Eurisys, St. Quentin en Yvelines, France.

