



STATE RESEARCH CENTER OF RUSSIA
INSTITUTE FOR HIGH ENERGY PHYSICS

IHEP 95-108

Yu.P.Gouz, Yu.M.Ivanyushenkov, A.K.Konoplyannikov,
V.F.Obraztsov, V.A.Sen'ko, N.A.Shalanda, E.V.Vlasov
IHEP, Protvino
T.Camporesi
CERN

**LED MONITORING SYSTEM
FOR THE STIC CALORIMETER**



SC9613

Submitted to *NIM*

Protvino 1995

Abstract

Gouz Yu.P. et al. The LED Monitoring System for the STIC Calorimeter: IHEP Preprint 95-108. – Protvino, 1995. – p. 7, figs. 8, refs.: 3.

A system and circuit diagrams of the LED monitoring system for the STIC calorimeter are described. The system allows one to produce independent light pulses for 320 channels of the detector and emulate signals from electrons from 0 to 30 GeV. Early experimental results of the usage in DELPHI are shown.

Аннотация

Гуз Ю.П. и др. Светодиодная система мониторинга калориметра STIC: Препринт ИФВЭ 95-108. – Протвино, 1995. – 7 с., 8 рис., библиогр.: 3.

Приведены описание и принципиальные схемы светодиодной системы мониторинга калориметра STIC. Система позволяет вырабатывать независимые световые импульсы для 320 каналов детектора и имитировать сигналы от электронов с энергиями от 0 до 30 ГэВ. Показаны первые экспериментальные результаты использования системы в установке DELPHI.

Introduction

Early in 1994 the SAT detector was replaced by STIC [1], to improve the calorimetry in the small angles region and to decrease a systematic error in the luminosity measurement down to $\sim 10^{-3}$. The luminosity measurement with such an accuracy needs monitoring of all the channels of STIC and trigger system [2]. For that purpose a LED-based system has been developed for the STIC calorimeter. The system allows one to produce independent light pulses for 320 channels of the detector, the intensity of the light pulses for each channel being computer controlled in the dynamic range $0 - 2^8$. The light pulses emulate the response of the calorimeter to electrons with the energy from 0 to 30 GeV.

1. System description

The block diagram of the STIC monitoring system is shown on Fig.1.

Four driver boards are placed on each side of the STIC detector (A and C). Each board generates electrical pulses for flashing up to 40 light diodes (LED). The blue light diodes (type 102CR-ND by the CREE company) have been inserted into plexiglass tiles which are arranged in a layer in front of the first converter plane of the calorimeter similar to the regular STIC detector planes. The generated LED blue light propagates inside the tile until absorbed by the fibers which stick-out of the calorimeter into the 2 mm holes in the tiles. The reemitted green light propagates inside the fiber to the photocathode of the tetrode. This design allows one to control the stability of the whole light detecting chain.

Each driver board has an identification address from 0 to 3. This address is selected with a switch placed on the printed circuit board. The driver board can drive any combination of LED variable pulse amplitudes. These selections are made via a 8 bit control bus. The data for the control bus, the power and the synchronization pulse are transferred from the control room to the driver board number 0 via ~ 40 meter t/p cables. The driver boards on each side of the detector are connected together through a serial data bus and

a serial coaxial chain, terminated by 50Ω at the end. The data bus signals are buffered at each driver board.

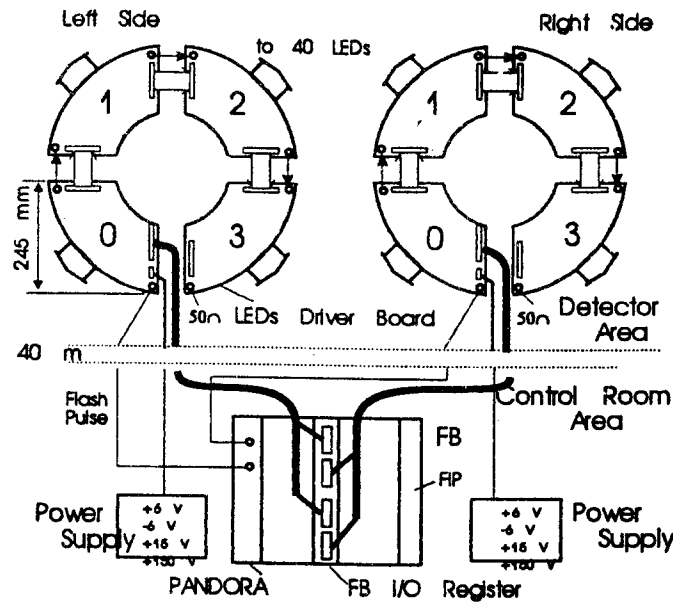

Fig. 1. The block diagram of the LED monitoring system.

The data are generated by FB I/O register (CAEN F687B), the synchronization pulses by the STIC TCU module [3].

1.1. Driver board description

The block diagram of the driver board is shown on Fig.2.

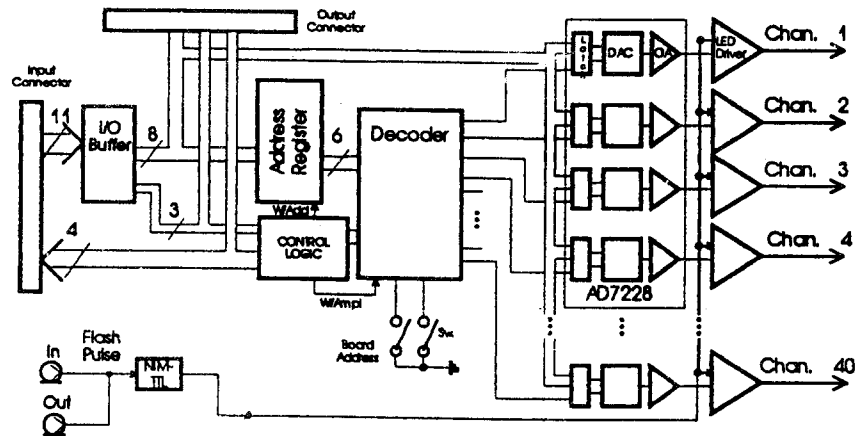

Fig. 2. The block diagram of the driver board.

The following functional parts are placed on the driver board:

- balanced input receivers of ECL signals;
- input address register;
- decoder of board number and channel number;
- five integrated circuits of 8-channels DAC, type ICAD7228;
- forty drivers for flashing the LEDs;
- switcher for addressing the driver board.

The control lines that come from the FB I/O register have the following meaning:

- address/data – 8 bits;
- control signal to select address or data (AD/DAT) – 1 bit;
- trigger signal (Strobe) – 1 bit;
- reset signal (Reset) – 1 bit;
- control respond signals, the correspondent bit becomes logical "1" when the board with the selected number exists and is 'alive' – 4 bits.

The data write cycle has two phases. In the first phase -- address phase – a connection with a selected board is established. The format of the address is:

- 3 bits (LSB) to select one of the eight DACs of IC AD7228;
- 3 bits to select one of the five IC AD7228;
- 2 bits (MSB) to select one of the four driver boards.

A logical level "1" on the control line AD/DAT defines an address phase. Fig.3 shows the timing diagrams for the signals.

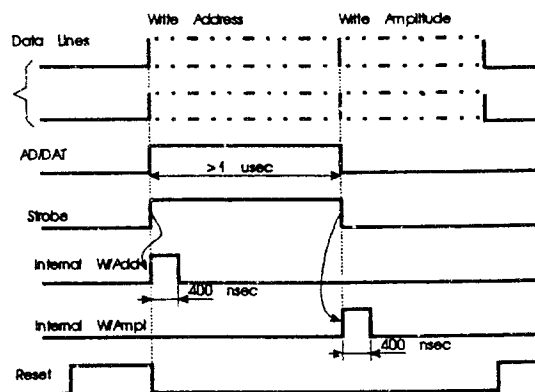

Fig. 3. The timing diagram.

In the second phase the value of the pulse amplitude for the LED selected before is written. At this time the control line AD/DAT has a logical level "0".

The logical level "1" on the Reset line clears the address register and disables the data writing.

The LED begins to flash when an external synchronization pulse (Flash Pulse) comes to the driver board.

The circuit diagram of one LED driver is shown on Fig.4.

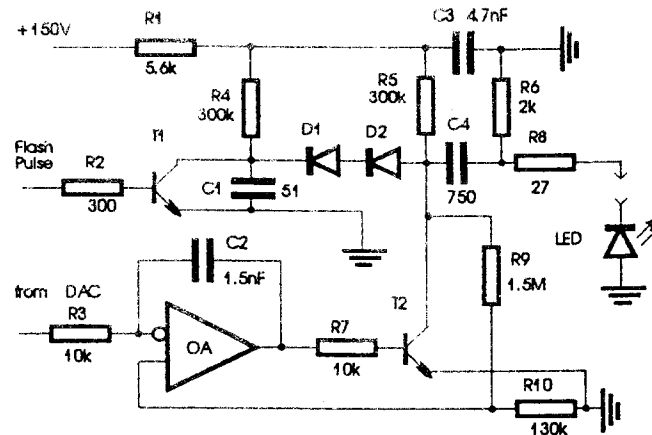

Fig. 4. The circuit diagram of the LED driver.

It consists of the following parts: a fast switcher - transistor T1, a discharge capacitor C4 and an amplifier based on the operational amplifier OA and transistor T2.

The capacitor C4 is charged up to a voltage $U_c = U_{dac} \cdot K$, U_{dac} being the DAC IC output voltage, K - the amplifier gain. The voltage U_c can be set in the range from 0 to 120 V. When the NIM Flash Pulse appears, the transistor T1 becomes switched on and the capacitor C4 is discharged through T1, diodes D1 and D2, resistor R8 and LED. The LED current and hence the light intensity is proportional to the value of U_c . The minimum width of the Flash Pulse should be ~ 300 nsec to provide the full discharge of the C4. This is important if high LED pulse stability is required. The transistor T1 works in the avalanche operating mode. In this particular application we use the avalanche transistor not because of its extremely high speed but just because it is a cheap and compact high-voltage switch. The diodes D1 and D2 have a break-through voltage of more than 200 V. They isolate the amplifier output from the switch T1.

Four power supplies are used. The power consumptions for each driver board are as follows: 400 mA (+6 V), 110 mA (-6 V), 65 mA (+15 V), 20 mA (+150 V).

The temperature stability of the electronics system is better than 0.03% per $^{\circ}\text{C}$, the variation of the charge injected into LED is (RMS) $< .1\%$ for the maximum signal.

2. Some results of the system operation

The dependence of the flash amplitude (for some channels), versus the DAC code is shown in Fig.5.

The measurements were done in DELPHI under working conditions with 1.2 T magnetic field. It is seen that the dependence is linear above some 'pedestal' value of the code

(~ 50). The dynamic range of the signal is 0 – 30 GeV. The relative width of the signal line rms/E^- versus the amplitude for the same channels is shown in Fig.6.

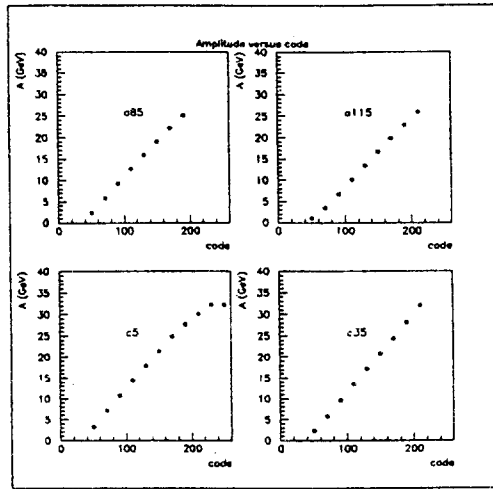

Fig. 5. Amplitude in 4 selected channels versus DAC code.

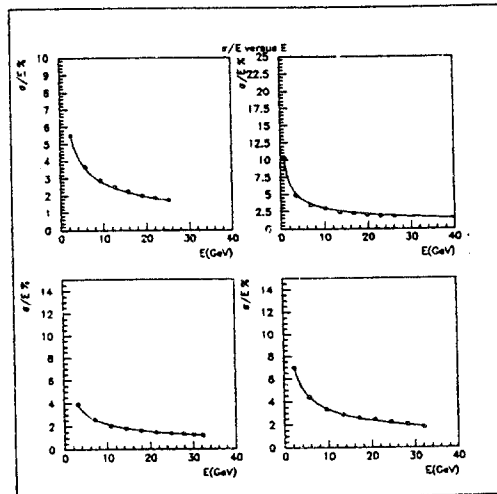

Fig. 6. Relative width of the signals versus the amplitude.

The dependence follows $E^{-1/2}$ law giving an evidence that the line width is determined by the photoelectron statistics and tetrode peculiarities and not by the noise or instability of the monitoring system itself.

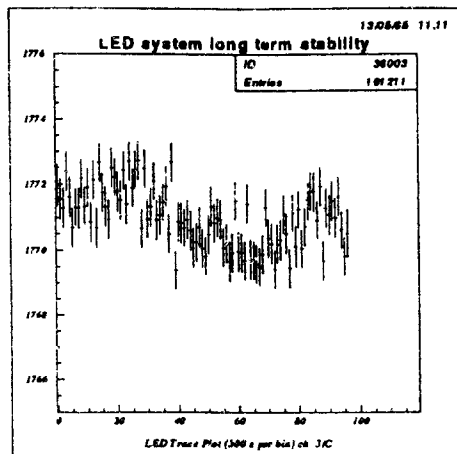

Fig. 7. The long term stability of the LED monitoring system.

The long-term stability of the system is illustrated by Fig.7, where the response of one channel, averaged over 5 min period is monitored during 7 hour period - a typical LEP fill lifetime. The variation of the response is within the band $\pm 0.15\%$. As an example of the LED-system application for the tests of the STIC trigger Fig.8 shows the dependence of the trigger efficiency versus a signal averaged over 320 channels.

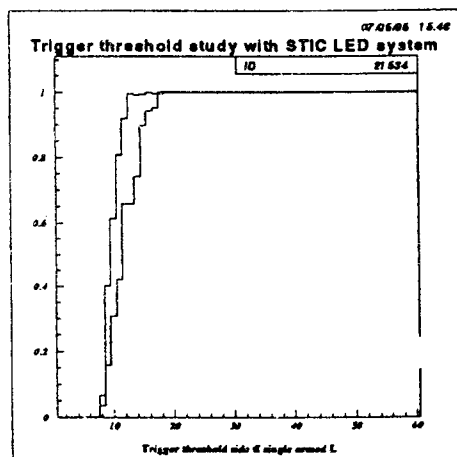

Fig. 8. The efficiency of the STIC trigger versus energy (in GeV) as determined by the LED monitoring system. (The curves for sides A and C are superimposed).

Conclusions

A new type of multichannel LED monitoring system has been developed for the Delphi STIC detector. The system allows to produce light pulses emulating response of the calorimeter to electrons in the range 0 – 30 GeV independently for 320 STIC channels. This feature gives a unique possibility for testing the trigger system. The high stability (at the level of 0.1%) allows one to monitor the long-term behaviour of the detector. The

system was installed in 1994 and has been in full operation since the beginning of 1995 LEP run.

3. Acknowledgements

We would like to thank A.M.Zaitsev for the support of this work and V.Hedberg for the help during the installation and tests of the monitoring system.

References

- [1] A.Benvenuti et al. CERN/LEPC/92-6 (1992);
A.C.Benvenuti et al. Delphi 94-157 CAL 120, 1994, Contribution to IEEE NSS Symposium, 1994.
- [2] S.J.Alsvaag. Univ. of Bergen Scientific/Technical Report No. 1991-27.
- [3] J.C.Wikne. Univ. of Oslo, Report 91-17 ISSN-0342-557.

Received July 20, 1995

Ю.П.Гуз и др.

Светодиодная система мониторинга калориметра STIC.

Оригинал-макет подготовлен с помощью системы ЛАТХ.

Редактор Е.Н.Горина.

Технический редактор Н.В.Орлова.

Подписано к печати 07.08.95. Формат 60 × 84/8. Офсетная печать.

Печ.л. 0,87. Уч.-изд.л. 0,67. Тираж 240. Заказ 390. Индекс 3649.

ЛР №020498 06.04.92.

ГНЦ РФ Институт физики высоких энергий
142284, Протвино Московской обл.