



EURO

CERN LIBRARIES, GENEVA



SC00000143

CLEAR RESEARCH

CERN/DRDC/90-66
Addendum DRDC/P10
October 18, 1990

SCP
©ERN - DRDC
90-66

ADDENDUM to

Detector tests in a high magnetic field and muon spectrometer triggering studies on a small prototype for an LHC experiment

Proposal submitted to the Detector R&D Committee

G. Ambrosi⁵, T. Barillari³, M. Basile¹, R. Battiston⁵, J. Berbers², F. Bergsma², H. Castro⁶, L. Cifarelli¹, F. Cindolo⁴, A. Contin², S. De Pasquale¹, J. Galvez⁶, S. Gentile³, P. Giusti¹, J. C. Labbe², G. Laurenti², G. Levi⁵, Q. Lin⁶, G. Maccarrone¹, R. Nania¹, F. Rivera⁶, G. Sartorelli¹, M. Schioppa⁶, A. Sharma⁶, G. Simonet², J. Solano⁶, G. Susinno³, L. Votano⁴, and A. Zichichi²

**Bologna¹, CERN², Cosenza³, LNF⁴, Perugia⁵, World Lab.⁶
collaboration**

Spokesman: G. Susinno
Contact person: G. Laurenti

Abstract

The "Large Area Devices" group following the R & D work done in the LAA project has submitted a proposal to the Detector R&D Committee (DRDC - P10) for detector tests in a high magnetic field and muon spectrometer triggering studies on a small prototype for an LHC experiment. Some specific points already mentioned in the proposal are more extensively discussed.

213979

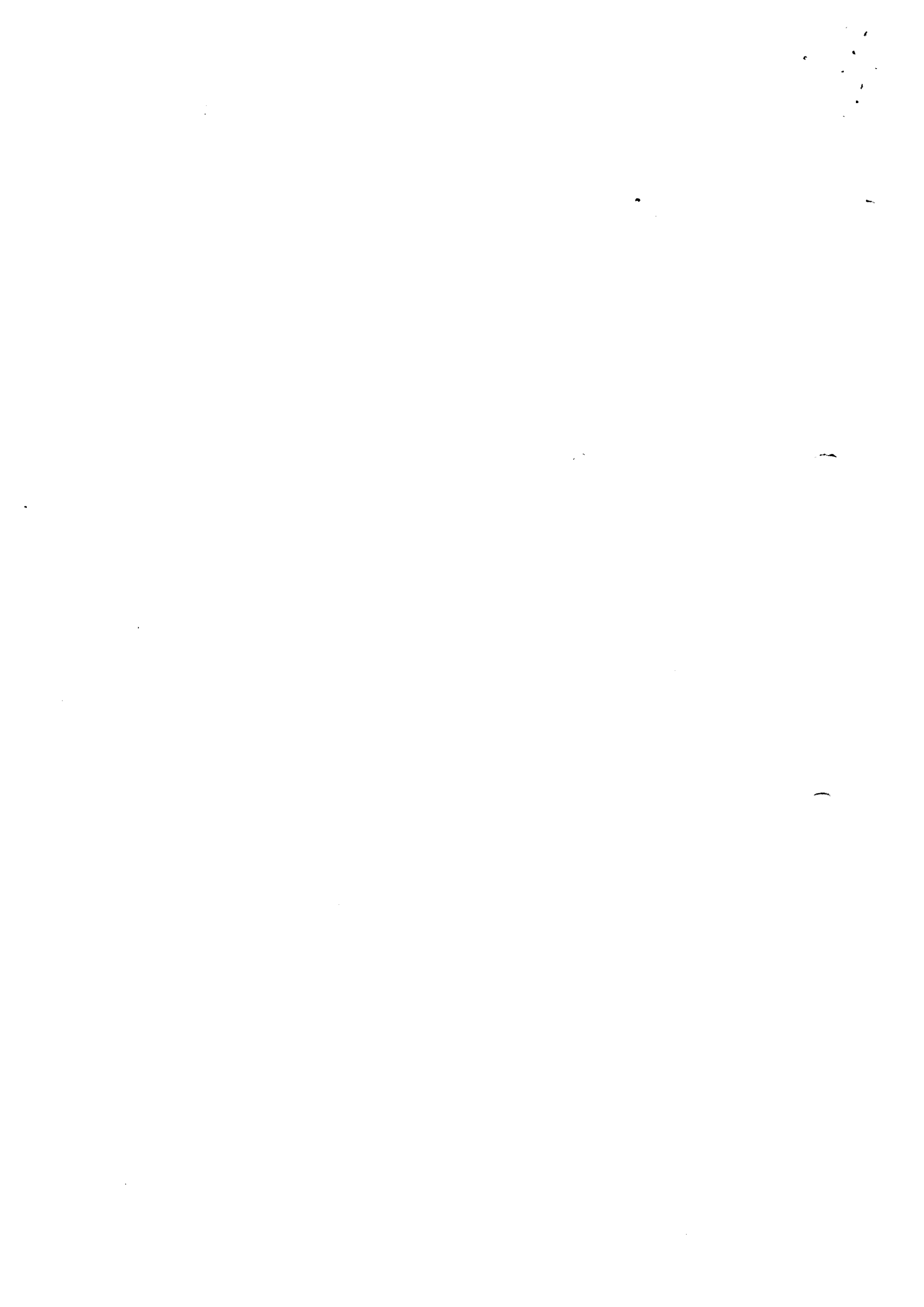

Introduction

Some specific points already mentioned in the DRDC-P10 proposal are more extensively discussed in this addendum. The comments made by our referee D. Saxon were of great help to identify the topics requiring more explanation.

First research and development activities on blade chamber prototypes are described. Then the trigger logic of the muon spectrometer under study for an LHC experiment and the beam set-up proposed for testing it are discussed. Finally, the possible milestones and budget requirements are indicated.

1 Blade Chamber studies

1.1 Chamber efficiency

The first prototype was made with a cell width of 8.5 mm and a wall thickness of .5 mm. This produced a dead area of 6% for particles crossing the chamber orthogonally.

The thickness of the walls was decreased in the subsequent prototypes and is 100 μm at present, giving a geometrical dead area of 1.2% only.

The sensitive volume of the chamber is sketched in fig.1 for two adjacent cells. In the case of a particle entering the chamber with an angle θ respect to the normal to the chamber, the inefficiency due to the walls is even more reduced.

Furthermore a detector plane is made of a multilayer system of blade chambers to reach the needed resolution . A cell displacement in the layers will practically reduce to zero the dead area.

1.2 Chamber read-out

Results were obtained until now using standard electronics available at CERN, at which chamber signals were sent through long cables. A new read-out particularly suited to the Chamber has been developed and built to increase the performances of the Chamber.

An efficiency curve(fig.2) , obtained with an amplifier designed for the chamber and directly mounted on the prototype, shows an operating point at lower HV and a substantial increase of the plateau length with respect to the preliminary results . In this prototype the wall thickness was 100 μm .

Further developments are needed in order to get an optimized low cost read-out. Its characteristics may also depend on the cell length of the Blade Chamber.

These developments are a part of the present R&D proposal.

1.3 Large prototype construction

A prototype with curved cells with an inner radius of 1 m and an outer radius of 1.8 m is under construction.

This prototype (fig.3) is intended to study construction problems on a real scale and to analyze signal response for different cell lengths. Precision mounting will require to find engineering solutions such to allow for easy construction keeping, at the same time, reliability and mechanical stability of the chamber. Survey and metrological controls on large surfaces has to be employed to ensure required precisions.

Also other aspects of the Blade Chamber construction and operation need studies and are subject of the project.

In particular effects related to extensive continuous testing are needed in order to analyze problems related to:

- Plastic corrosion
- Plastic and sealants out-gassing
- Electrode deposits and/or corrosion

1.4 Gas studies

The use of flammable gases like isobutane should be avoided if possible in a real experiment.

For this reason we are undertaking studies to find less dangerous mixtures. Some test have already been done in CERN and in PERUGIA using mixtures containing CO_2 and CF_4 .

A prototype chamber has been tested using cosmics and on a test beam . Results are given in fig. 4,5 showing efficiency curves of different mixtures.

TDC spectra are shown in fig 6 for CF_4 mixture and pure Isobutane, demonstrating that adding CF_4 can reduce the total drift time in a cell.

1.5 Ageing studies

The typical size of the streamer charge in the blade chamber is 40 to 80 pC depending on the operating voltage and on the mixture used. At a luminosity $L = 4 \cdot 10^{34} \text{ cm}^{-2} \text{ sec}^{-1}$ the maximum rate on the forward chambers will be about 1 KHz/cm². Test results with pure isobutane have already shown that the chamber can be safely operated at this rate. We want to make additional tests to measure the flux limit.

The design of new front end electronics, allowing to work at lower high voltage and more studies on gas mixtures are the points to elaborate on.

Assuming a maximum flux of 1 KHz/cm² one would integrate in one year of operation $10^7(\text{sec}) \cdot 10^3(\text{Hz/cm}^2) \cdot 60(\text{pC}) = 0.6 \text{ C}/(\text{cm}^2 \text{ year})$. While data on radiation ageing of Blade Chambers do not exist, the existing data on wired streamer tubes (measurements performed by the SLD Collaboration) show that after more than 5 C/cm² with Ar/Iso mixture at a fixed operating point the average charge/pulse did decrease by only 13%. We plan to perform ageing test on blade chambers in operating conditions.

1.6 Studies in a magnetic field

As already emphasized in the P10 proposal, studies are needed for the chamber behaviour in a magnetic field. The gas amplification takes place around the sharp edge of a blade. Applying a high magnetic field will give rise to an asymmetry in the signal of electrons approaching the blade from different sides: from one side the electrons would be pushed towards the high field region, from the other side they would be pushed away from it.

This effect is not expected to be prohibitively large. In fact the electric field around the tip of a blade decreases more slowly than around a wire. This means that for the same amplification field on the anode the electric field along the drift lines is higher in a blade chamber than in a wire chamber, so the Lorentz angle is reduced. The effect has been calculated for a 2T magnetic field parallel to the blades and a constant electron drift velocity $w = 40 \text{ } \mu\text{m/ns}$.

In fig 7a and 7b are drawn the drift lines without and with the magnetic field, the active volume of the cell being the one above the arrows. In fig 8 field and equipotential lines are drawn near the tip of the blade, showing the high field region.

The simulation shows that applying a magnetic field the active volume is reduced in one side of the cell with respect to the other, but it remains large enough to allow for a good efficiency.

In any case the chamber efficiency has to be measured in a test performed in a high magnetic field (1-2 T). If necessary it could be improved by creating some asymmetry in the cell geometry or by the use of a slower gas.

A conventional magnet with a 1.5-1.8 T field in which our small chambers (30x30 cm²) could be inserted, would be sufficient for first studies on the Blade Chamber behaviour in a high magnetic field.

1.7 Further work on Blade Chamber R&D

As discussed in previous sections much work can still be done on Blade Chamber developments in order to optimize this new promising detector. This can be resumed in the following priority list:

- a) Front-end electronics
- b) Gas studies
- c) Large prototype construction
- d) Ageing studies
- e) Test in a high magnetic field

Different cell designs are moreover conceivable. A conductive blade could be substituted by an insulating blade with a conductor deposit on the tip. This would still allow for a flexible geometry and has the advantage of a field configuration closer to a wire cell.

2 Muon spectrometer studies

2.1 Trigger logic

We are studying a solution for a muon spectrometer making use of superconducting air-core toroids, solution presented at ERICE " Workshop on New Technologies For Supercolliders "(15 - 20 Sept. 1990) and at the last Aachen ECFA workshop (4 - 9 Oct. 1990). Among other advantages, like a very high muon momentum resolution over a large pseudorapidity range, it allows for a magnetic shielding of the calorimeter punch-through.

The punch-through momentum distribution is strongly enhanced at low momenta, as shown in fig. 9 [1] . In fig. 10 trajectories of muons of different momenta inside the spectrometer are shown: tracks of momenta below 1 GeV/c are always bent back.

Monte Carlo studies are going on for a precise evaluation, but it can already be concluded that the probability for a punch-through track to arrive at the outer detector plane is very low.

The trigger will be defined by hardware roads connecting the intermediate and outer muon planes to the vertex. A track is accepted if the hit in the outer plane is within a preselected interval from the position of an infinite momentum track passing through the hit in the intermediate plane.

In fig. 11 the trigger probability as a function of the muon momentum is given for different granularity of the detectors and different intervals of accepted cells. Results were obtained simulating the proposed spectrometer using GEANT as simulation program. Effects due to multiple scattering and vertex displacement along the beam were taken into account. The calorimeter was assumed to be 2 m of lead equivalent. For current LHC design [2] the two beams have to cross each other under a small angle in order to avoid collisions of particles belonging to one bunch with particles from more than one other bunch. The bunches have a roughly gaussian shape with a sigma of about 7.5 cm. This means that the distribution of interaction points is also gaussian with a sigma of $7.5/\sqrt{2}=5.3$ cm.

2.2 Spectrometer test on a small prototype

The assembling of a CERN high energy beam line, equipped with a strong field magnet could give the opportunity to test on a small prototype the trigger logic previously described.

The most relevant points we would like to analyse are:

- Muon identification
- Muon momentum cut

The first point strongly depends on punch-through rates and momentum spectra of exiting particles for different incident pion momenta and calorimeter depths.

2.3 Test set-up

The test set-up should be composed of a calorimeter in front of the magnet and a subsequent muon identifier for consistency checks. At a first stage the calorimeter could be substituted by a simple absorber.

The calorimeter should be at least 12λ thick with the possibility of increasing its depth.

The CERN H2 beam line, equipped with the EHS superconducting magnet could perfectly meet our requirements.

Another group (DRDC - P7) has proposed to make muon trigger studies for a compact solenoid spectrometer on the same beam line which could be easily used by both groups. The difference between the two set-ups is the position of the calorimeter that in our case should be positioned outside the magnet (before). A simple mechanical system can be built to allow the necessary movement.

3. Milestones

The following milestones should be reached for the end of 1991:

- Construction of a large prototype, test on a beam. (Two one week period on a PS beam).
- Development and construction of a dedicated front end electronics, test on the large prototype.
- Tests of small prototype working in magnetic field. (Two one week periods on a PS beam equipped with a magnet.)

When the EHS magnet will be available, (1992) we plan to make the proposed tests on triggering and tracking capabilities of the described spectrometer. For this purpose we will have to build complete detector planes. At least two additional years of activity are required for this part.

4. Budget 1991

During the year 91 the group activity will be dedicated mainly to the final development of the detector and the associated electronics .

The request for this year correspond to the first part of the table 1 of our proposal (detector test) reproduced here. Since for a part of these needs we have applied to other founding institutions , the part asked as CERN contribution is 200.000 SF.

Budget estimateDetector test

General material (CERN stores)	80	kSF
Material for prototype construction	80	
Mechanical workshop	30	
General instrumentation	60	
Laboratories, Gas room, Clean room, equipment	40	
Electronics workshop	60	
Electronics materials	30	
	<hr/>	
	380	kSF

References

- [1] EMPACT Collaboration. SSC-EOI-6 (1990)
- [2] LHC Pink Book, in preparation.

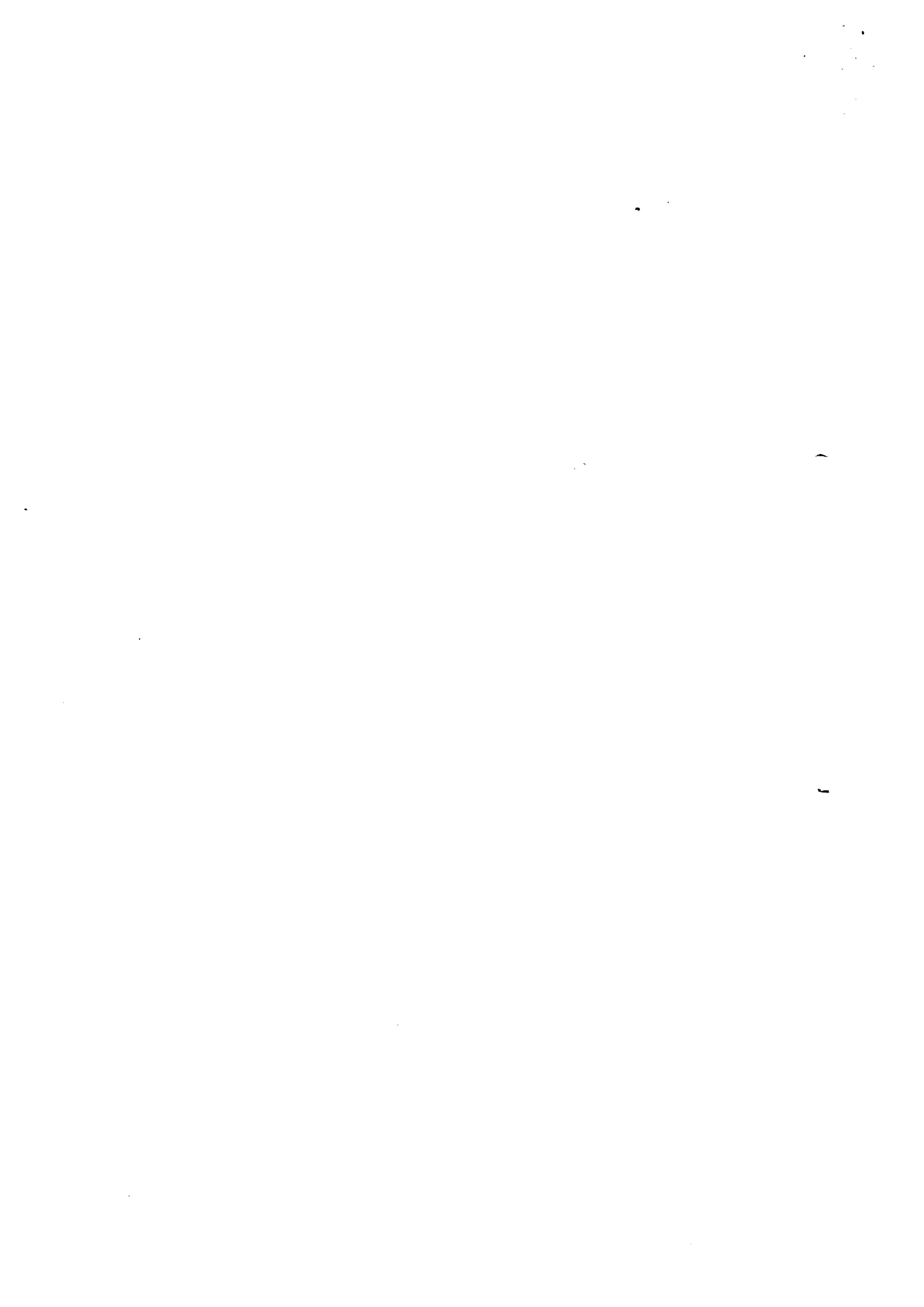

Blade chamber Cells

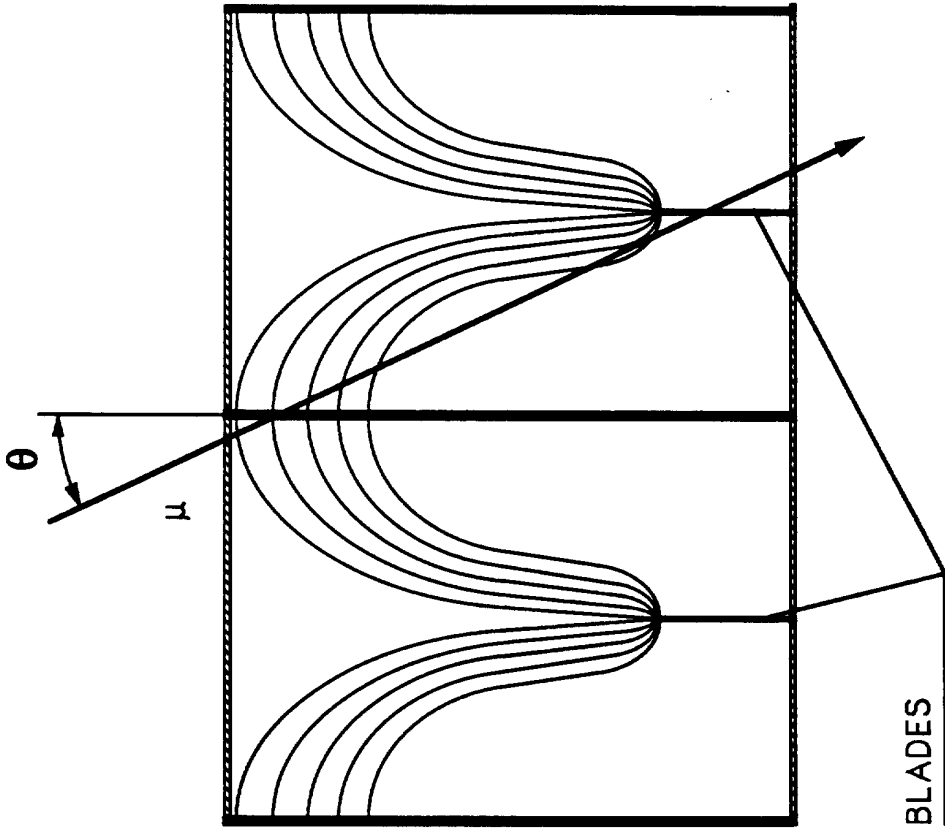
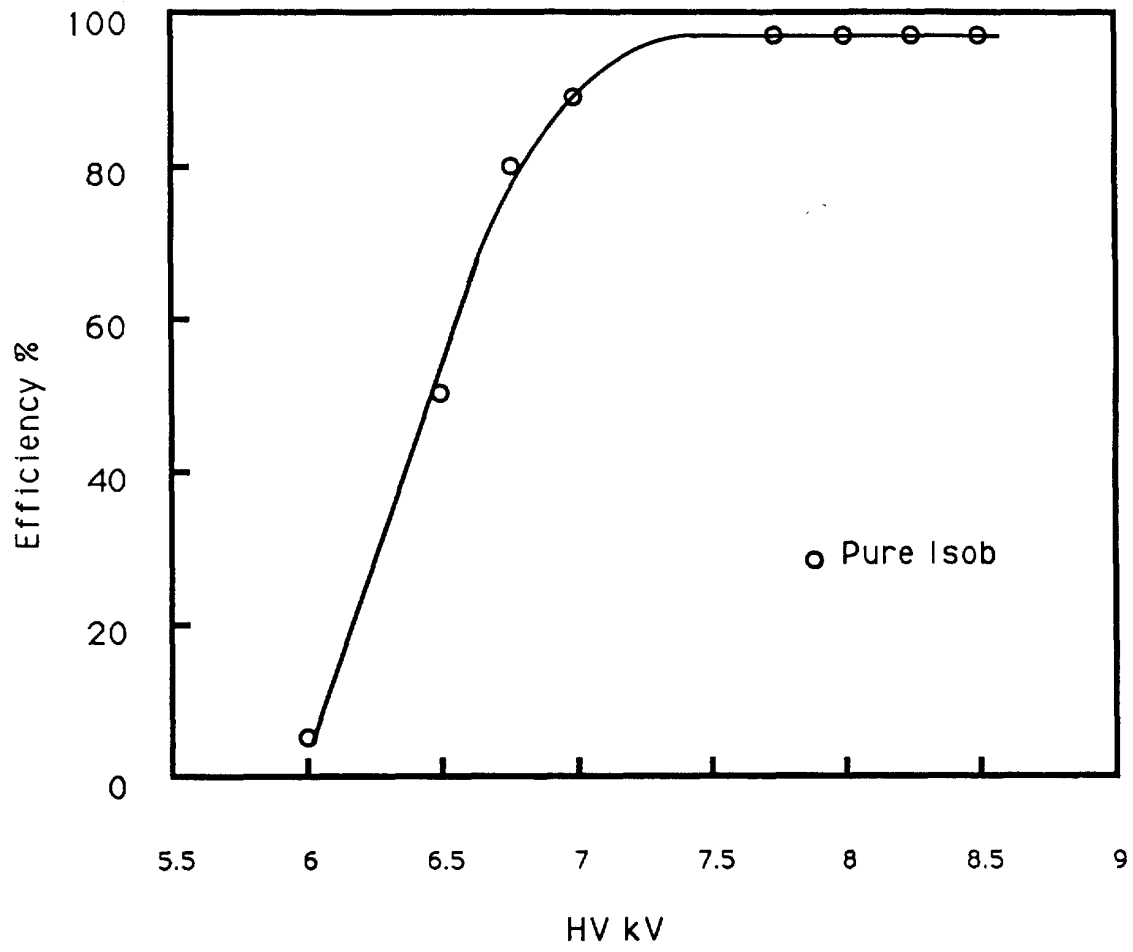

FIG 1

FIG. 2 EFFICIENCY ON COSMIC



CIRCULAR BLADE CHAMBER

BLADE POSITION TOP VIEW

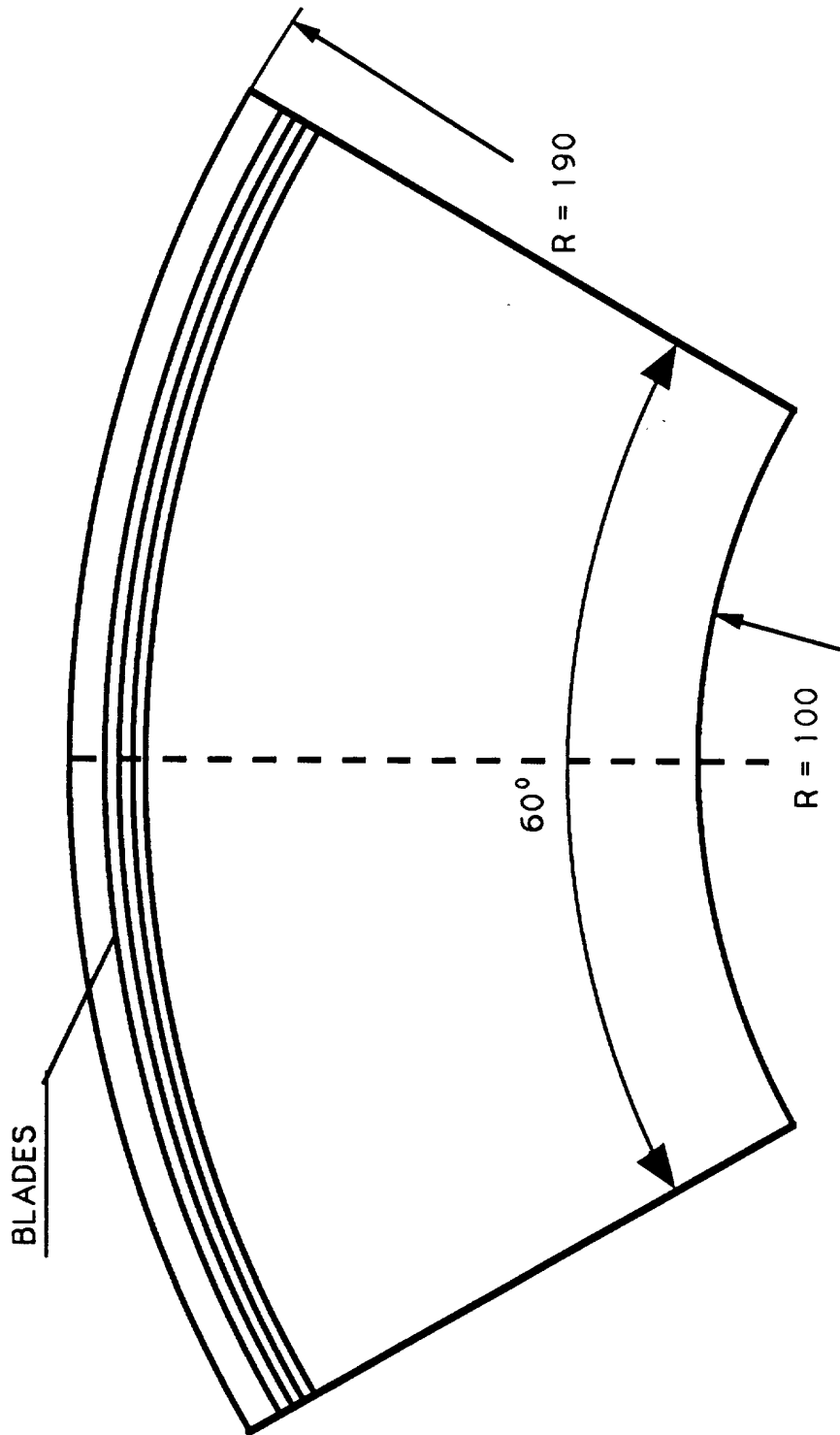

FIG 3

FIG. 4 EFFICIENCY CURVES FOR COSMICS

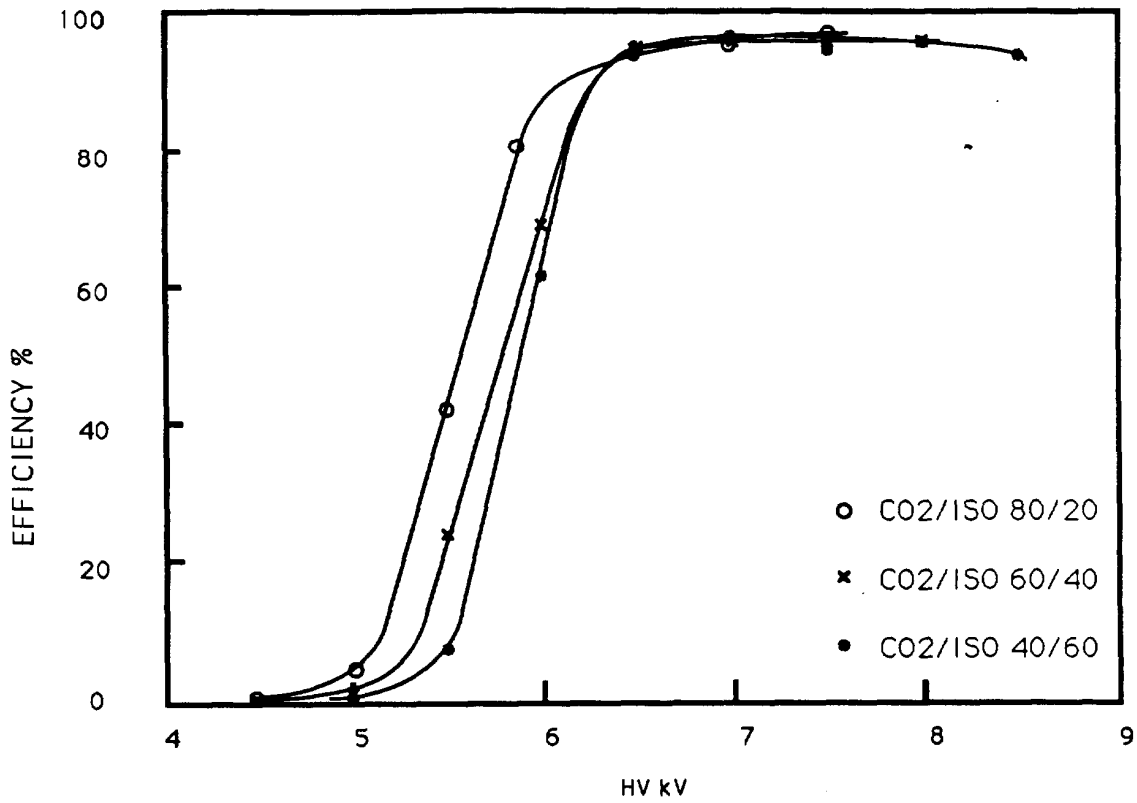
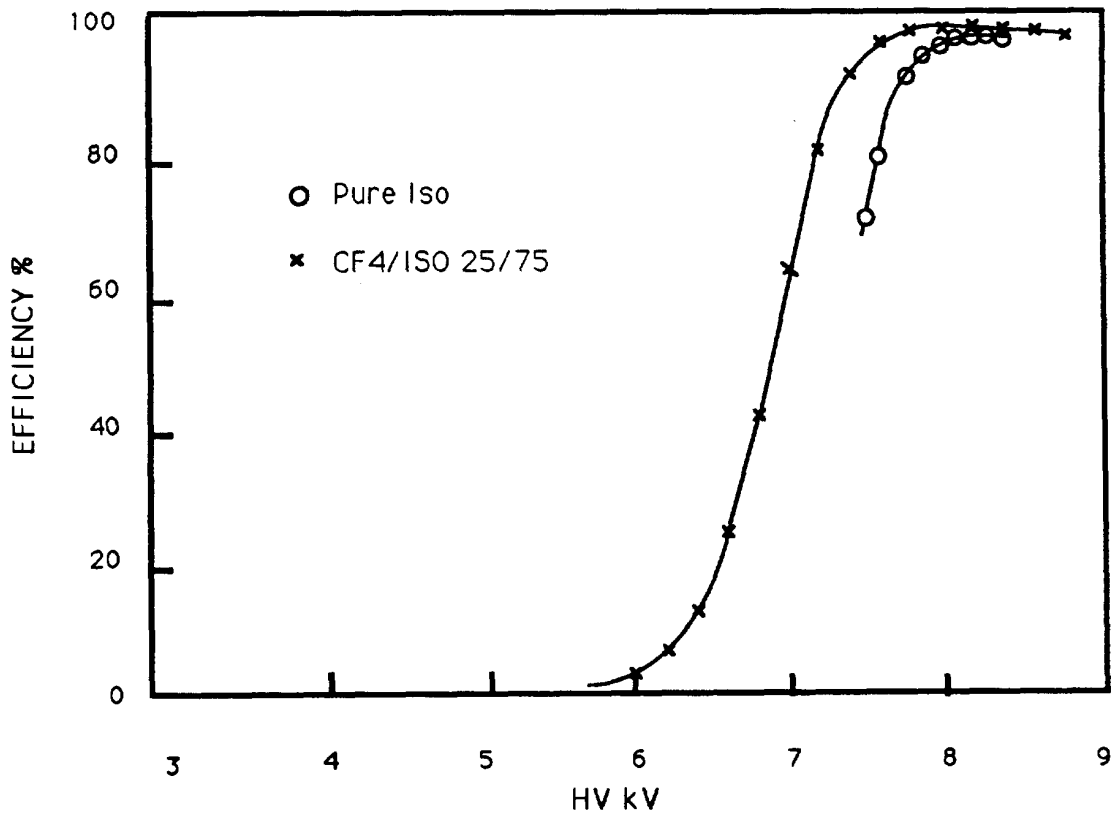

FIG. 5 EFFICIENCY CURVES ON BEAM



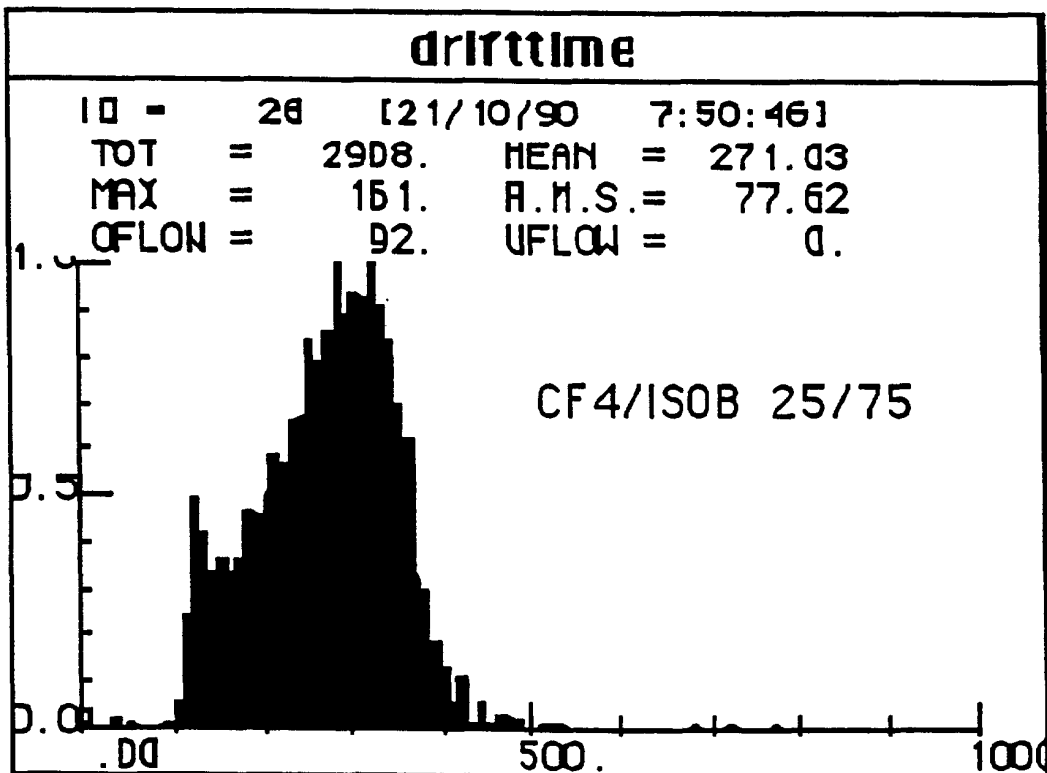
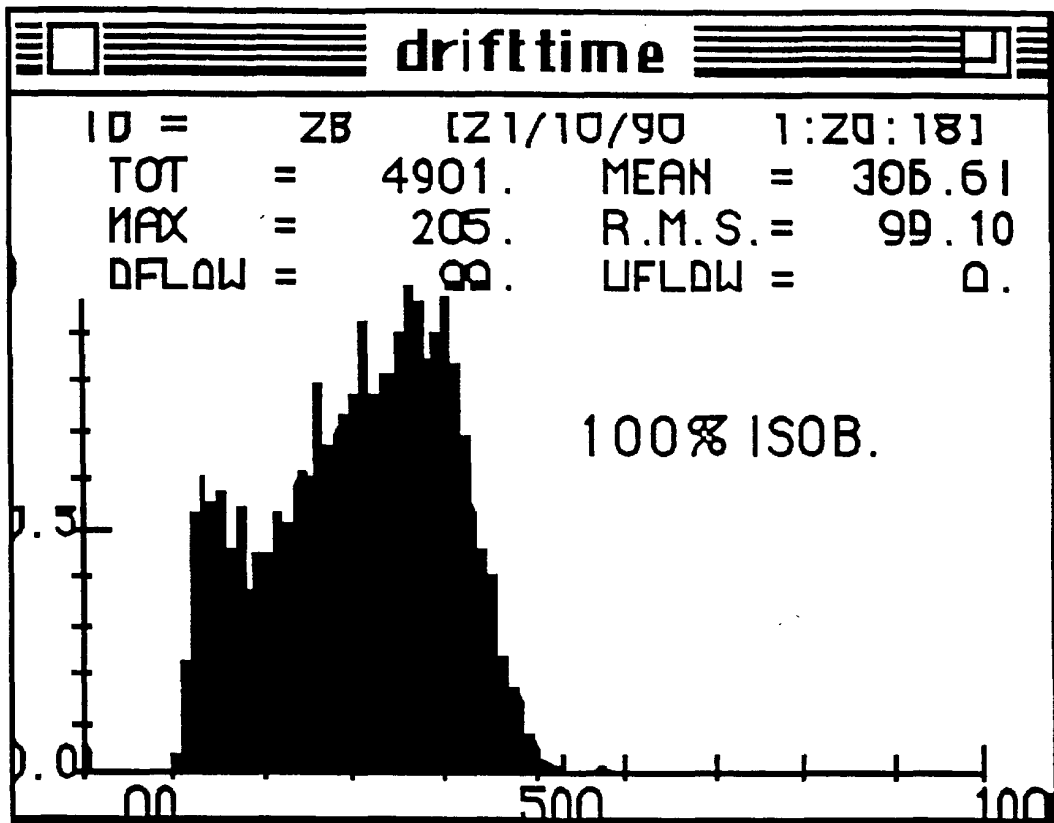

FIG. 6: On line plot of drift time spectra for two gas mixtures :

100 % Isobutane --- 25 % CF₄ - 75 % Isobutane

Horizontal scale : 2 counts/ns

0 Tesla , 9 KV

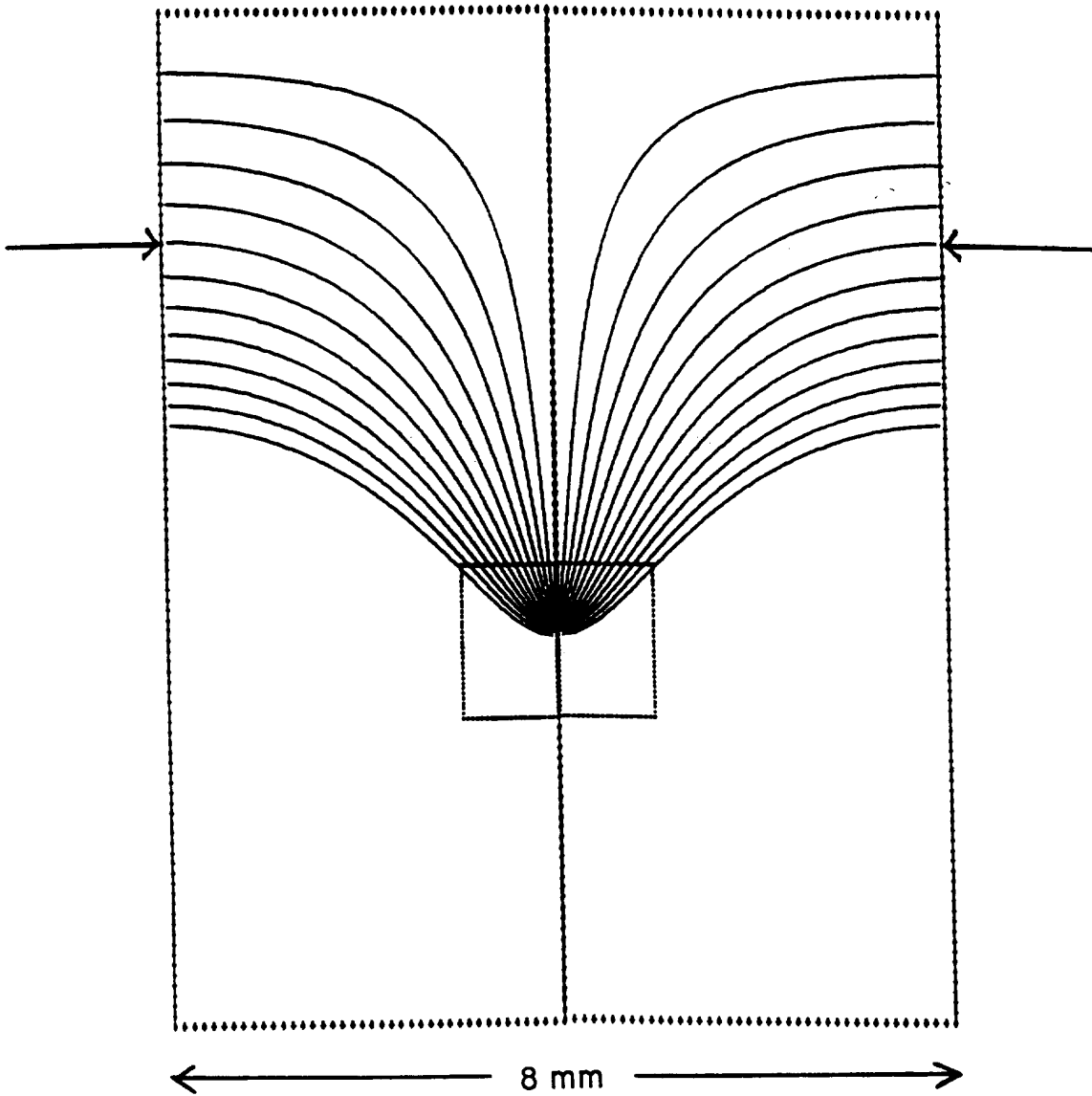

FIG. 7a Drift lines without magnetic field

2 Tesla , 9 KV

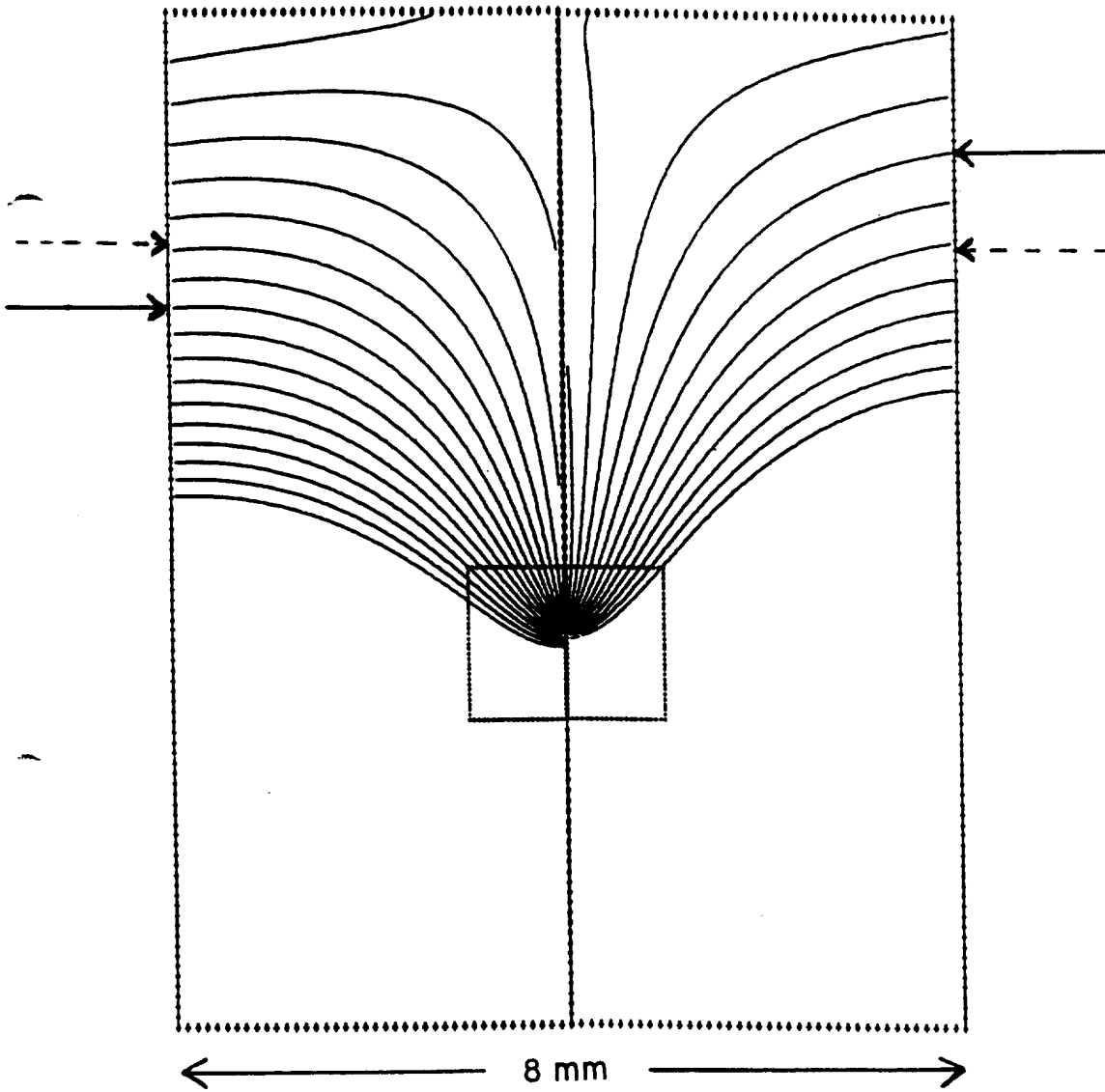

FIG. 7b Drift lines with 2 T magnetic field'

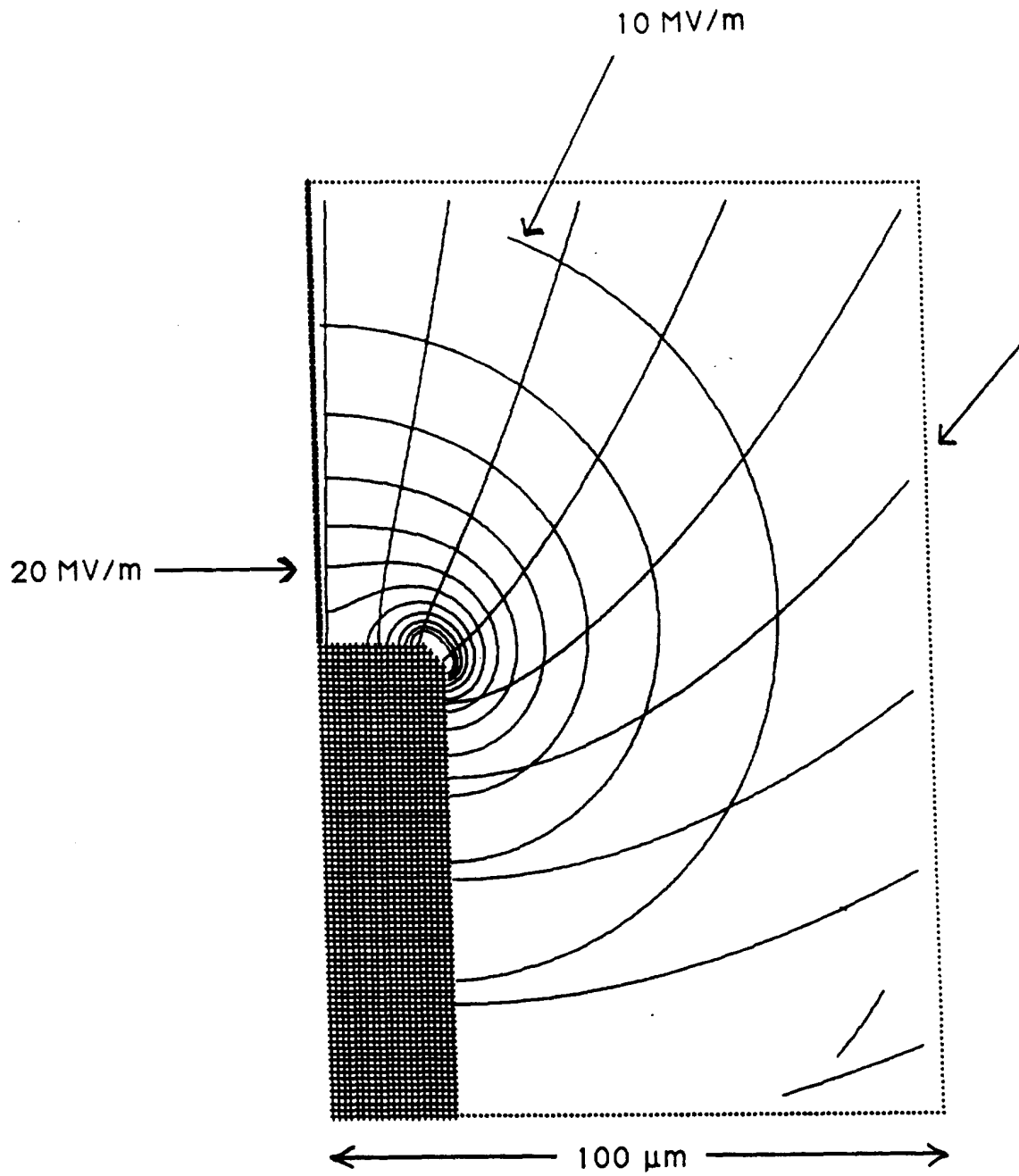
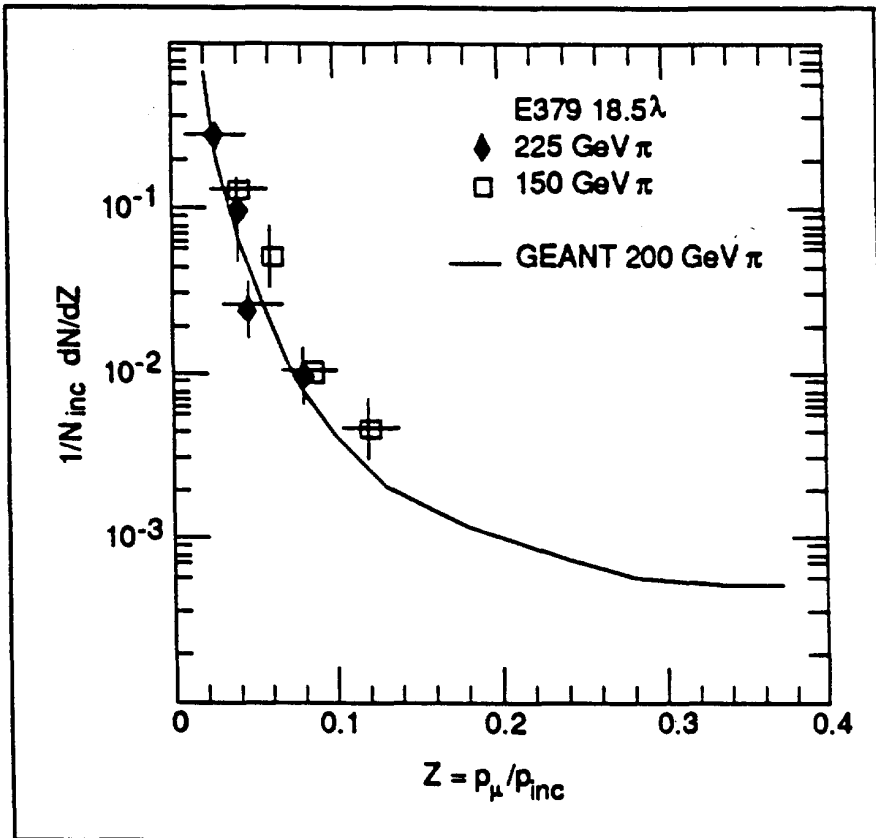
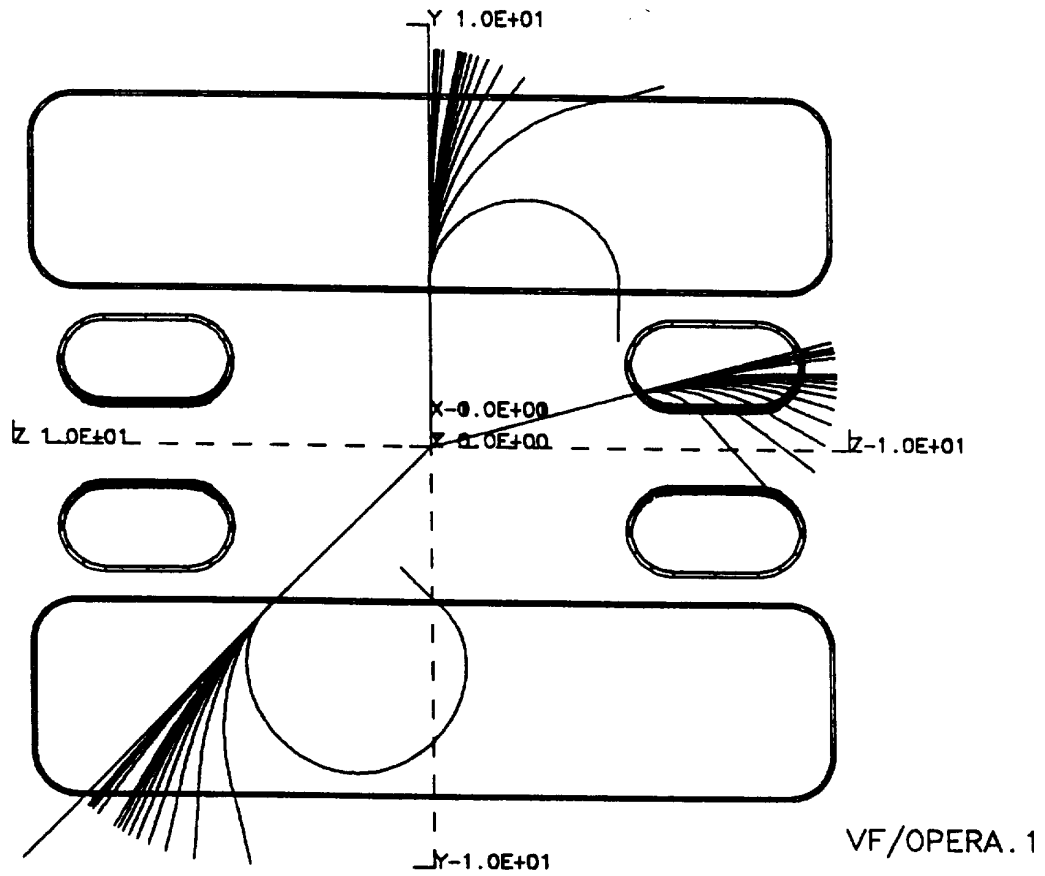

FIG. 8 Tip of the blade



**Momentum Spectra of Exiting Particles
for Different Incident π Momenta
Compared to Monte Carlo**

FIG. 9



Side view of the muon spectrometer. Tracks of: 1,2,3,.....
10,20,30,40,50 GeV/c are shown.

FIG. 10

FIRST LEVEL TRIGGER PROBABILITY

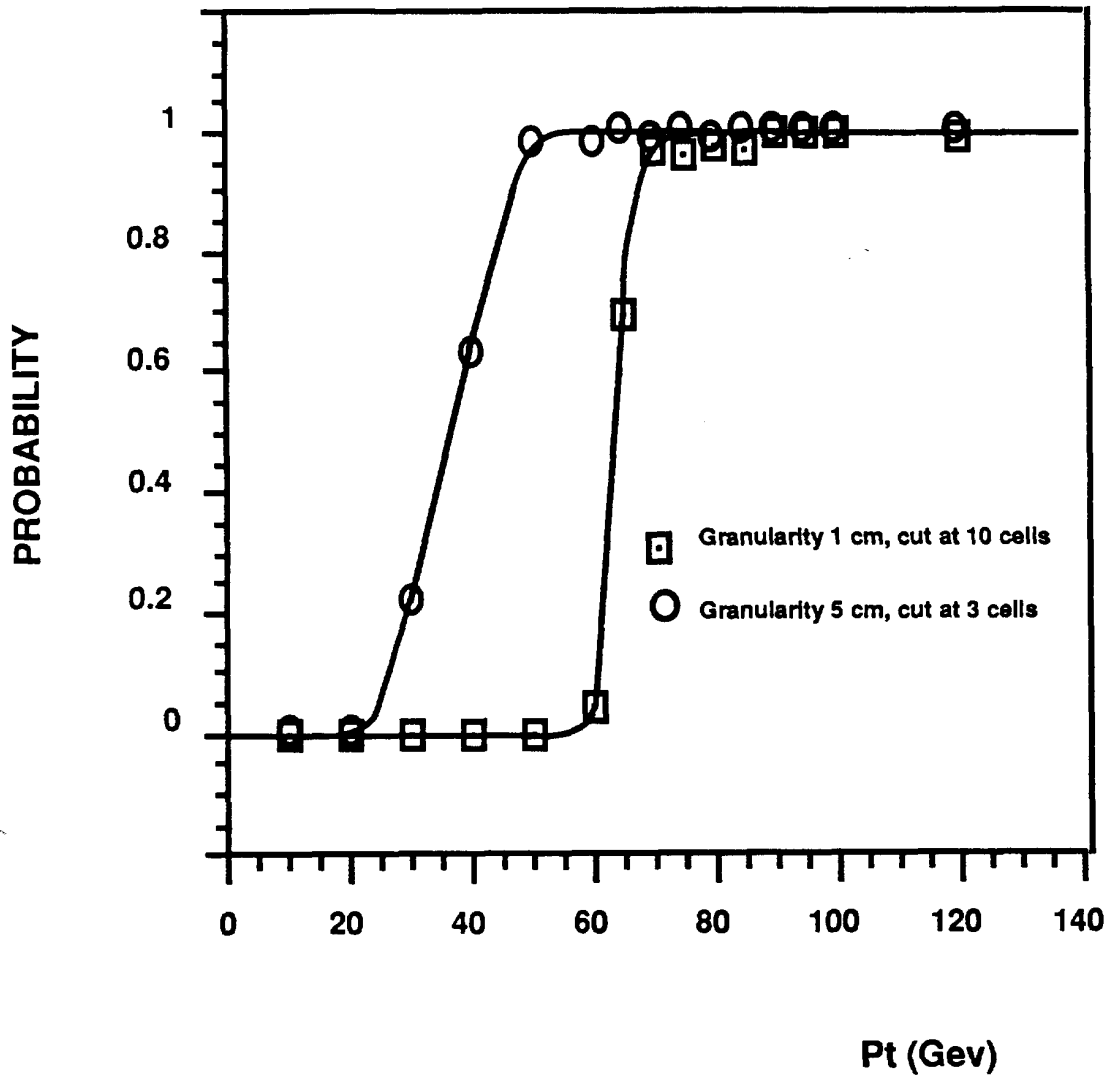

FIG. 11

10

11

12