

508067

IPNO-DRE. 95-14

**Latest polarization and beam characterization
results of the Orsay polarized electron source**

J. Arianer, S. Cohen, S. Essabaa, R. Frascaria
and O. Zerhouni
Institut de Physique Nucléaire, 91406 Orsay Cedex, France

Contribution to the International Workshop on Polarized Beams and Polarized Gas Targets,
Köln, Germany - June 6-9, 1995

LATEST POLARIZATION AND BEAM CHARACTERIZATION RESULTS OF THE ORSAY POLARIZED ELECTRON SOURCE

J. Arianer, S. Cohen, S. Essabaa, R. Frascaria and O. Zerhouni

Institut de Physique Nucléaire, 91406 Orsay Cedex, France

ABSTRACT

The Orsay polarized electron source based on the chemi-ionization of aligned He (2^3S_1) atoms and CO_2 molecules is briefly described. The latest results concerning electron polarization and beam emittance are presented. They reveal 82%-70% electron polarization for currents up to 30 μA and 60% for 100 μA . The maximum quality factor and normalized emittance are found to be $IP^2 \approx 3.9 \cdot 10^{-5}$ Amp (at 100 μA) and $\epsilon_n = 0.7 \pi$ mm mrad (at 1 μA). Finally we comment upon our present development status.

1. INTRODUCTION

The need for highly polarized electron beams, in cw accelerators, has led to considerable efforts towards the development of reliable sources presenting large quality factors. Today, promising in this direction are the sources based on photoemission from GaAs cathodes[1] and Penning ionization reactions involving optically aligned He(2^3S_1) metastables[2,3]. The Orsay polarized electron source makes use of the latter method. In what follows we shall expose the basic operational considerations as well as our latest measurements concerning electron polarization and beam emittance. In the light of these results it will be obvious that this type of source has reached the same high competitive level as the most performing GaAs one, nowadays. Furthermore due to its operational simplicity and reliability the He-afterglow source is in many respects even more attractive.

2. OPERATING PRINCIPLE

A polarized electron production, based on Penning ionization, makes use of the spin preserving nature of reactions of the following type:

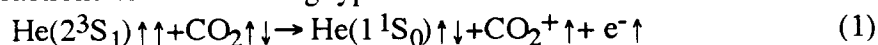

If the ensemble of metastable He atoms is aligned by optical pumping, before reaction (1) takes place, the atomic polarization is converted to electronic provided the target gas has a singlet electronic ground state. The conversion degree is close (if not equal to) unity but this depends on the nature of the gas. The CO_2 molecule is usually chosen as the He^* collision partner because it preserves 100% the polarization and it provides a high Penning ionization cross section.

The liberated electrons in (1) have initially a large energy spread of about 5.5 eV. This is undesirable because of the high diffusion losses and beam emittance degradation it implies. Then, another advantage of using CO_2 is its electron cooling efficiency to thermal energies due to its rovibronic excitation when colliding with the produced electrons.

3. DESCRIPTION OF THE SOURCE

A more detailed description of the source can be found elsewhere[3] so here we shall briefly present only its basic characteristics. Our set-up is schematically presented in figure 1a. A purified He gas flows through a Laval nozzle placed in a microwave cavity. The discharge preferentially excites He atoms to the 2^3S_1 metastable level. The 1000 l/sec Roots blower evacuating the system provides an average atomic flow velocity of ≈ 100 m/sec while the operating pressure ranges from 0.05 to 0.15 mbar. For these pressures the metastable density is $10^9 - 10^{10} \text{ cm}^{-3}$. The flow expands to a ≈ 30 cm straight pyrex tube. A 50 MHz RF coil is used at this point to eliminate (at least partially) parasitic charged particles. The Pyrex tube is connected to a metallic chamber where the optical pumping and the Penning reaction take place. Two laser beams, one circularly and one linearly polarized, pump optically the He metastables. Both are delivered by a broadband Kr-lamp-pumped LNA laser (4 Watts, 2.5 GHz linewidth) [4], very simple to operate. Optical pumping is carried out via the He $2^3S_1 \rightarrow 2^3P_0$ (D_0) transition as shown in figure 1b. The atoms are prepared to a selected $m_j = +1$ or -1 state depending on the helicity of the circularly polarized beam. The experimentally measured[5] atomic polarization is $\approx 92\%$ for pressures up 0.15 mbar (current $> 130 \mu\text{A}$).

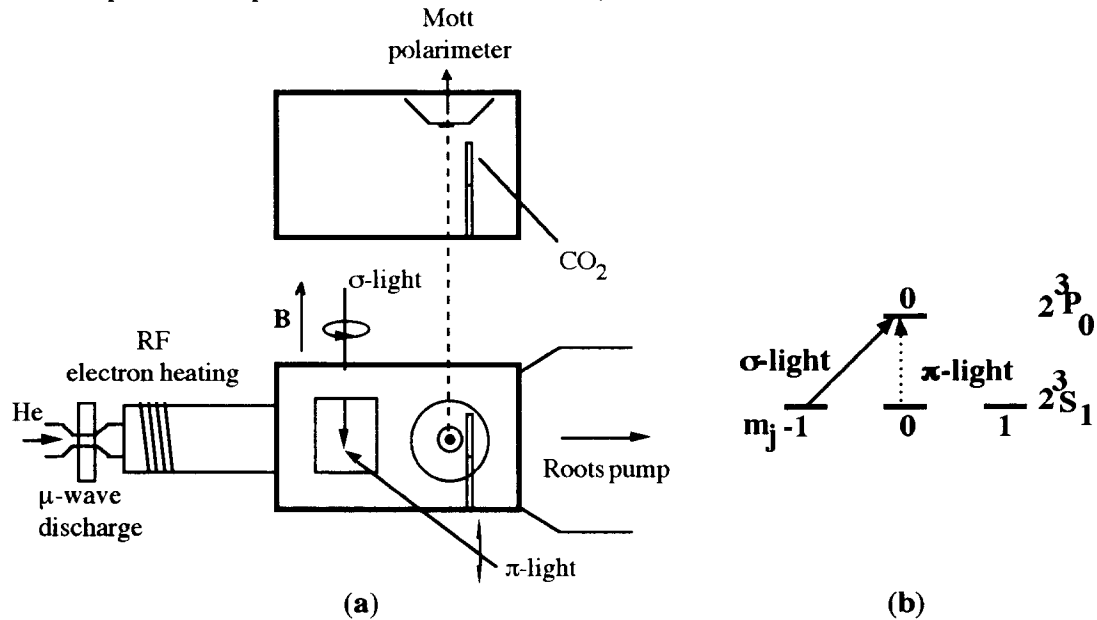

FIGURE 1. a) Schematic view of the source. b) Optical pumping scheme using He $2^3S_1 \rightarrow 2^3P_0$ (D_0) transition.

Three pairs of Helmholtz coils cancel the earth's magnetic field and provide a 2.5 Gauss highly homogeneous one ($\Delta B/B \approx 10^{-3}$) which defines the quantization axis and ensures efficient pumping. The quantization axis is perpendicular to the He beam and the electron extraction direction.

About 10 cm downstream the pumping region, CO₂ molecules are injected through a perforated copper ring and interact with the aligned atoms. The CO₂ pressure is 0.01-0.1 times the He one. The produced electrons are extracted from the chamber through a small hole (1-2.5 mm diameter) at the center of a metallic button mounted on a plexiglass cone (nozzle). Extraction is facilitated by biasing the chamber at a negative potential V_c with respect to ground ($-300 \leq V_c \leq 0$ Volts) and the nozzle at a positive V_b with respect to the

chamber ($30 \leq V_b \leq 0$ Volts). An electrostatic transport system directs the electron beam to a Mott polarimeter for polarization measurement.

4. RESULTS AND DISCUSSION

4.1 Electron Polarization.

Our concern, apart of obtaining an appreciable electron polarization at an extended and usable current range, is the source preparation for its proper installation to an accelerator environment. One of our goals towards this direction was the operation of the source with a grounded chamber ($V_c=0$ Volts)[3]. This, followed by a number of other modifications, has led to an improved performance with respect to our previous measurements[6]. The two sets of polarization (P) vs current (I) results shown in figure 2 were recorded with the chamber at ground or biased at -100 Volts. There is not any noticeable difference between them. Summarizing the present performance of the source, as far as polarization is concerned, we now obtain 82%-75% polarization for 0.1-3 μ A, 75%-70% for 3-30 μ A, $\approx 65\%$ for ≈ 60 μ A and $\approx 60\%$ for ≈ 100 μ A. This latter value leads to a maximum quality factor curve $IP^2 \approx 3.9 \cdot 10^{-5}$ Amp.

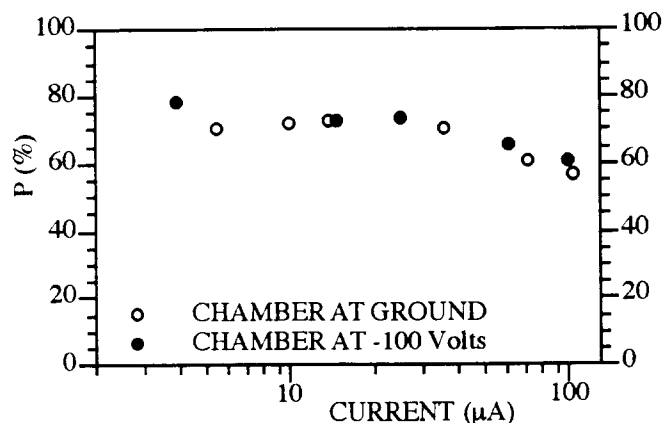

FIGURE 2. The Orsay polarized electron source performance with the interaction chamber grounded and biased at -100 Volts.

There are mainly two suspected causes for the electron depolarization at high currents (and hence pressures). The first one is the increasing number of unpolarized electrons coming from the microwave discharge and which are not completely removed by the applied RF field[3]. The second is the possible production of O_2 as a subproduct of the reaction (1)[7]. O_2 has a triplet ground state and thus spin exchanging $e + O_2$ collisions would depolarize the electrons. The above process is important at high CO_2 density and consequently at high current.

4.2 Emittance measurements.

Recently, we have performed beam emittance measurements using an apparatus loaned from the Max Planck Institute at Heidelberg, capable of a direct measurement within a few minutes (figure 3a). It was originally designed for measurements using positive ion beams of high energy. Here, however we were limited to low electron energies (≈ 200 eV) and the high current measurements suffered from a large secondary electron production. Thus, we were obliged to work at currents $I \leq 1$ μ A. Figure 3b shows a typical measurement. The normalized emittance was found to vary in the range

$\epsilon_n = 0.45 - 0.7 \pi \text{ mm mrad}$ (80% of the total current) depending on different conditions. These included percentage of CO_2 with respect to He pressure for a given current, nozzle and extraction biases.

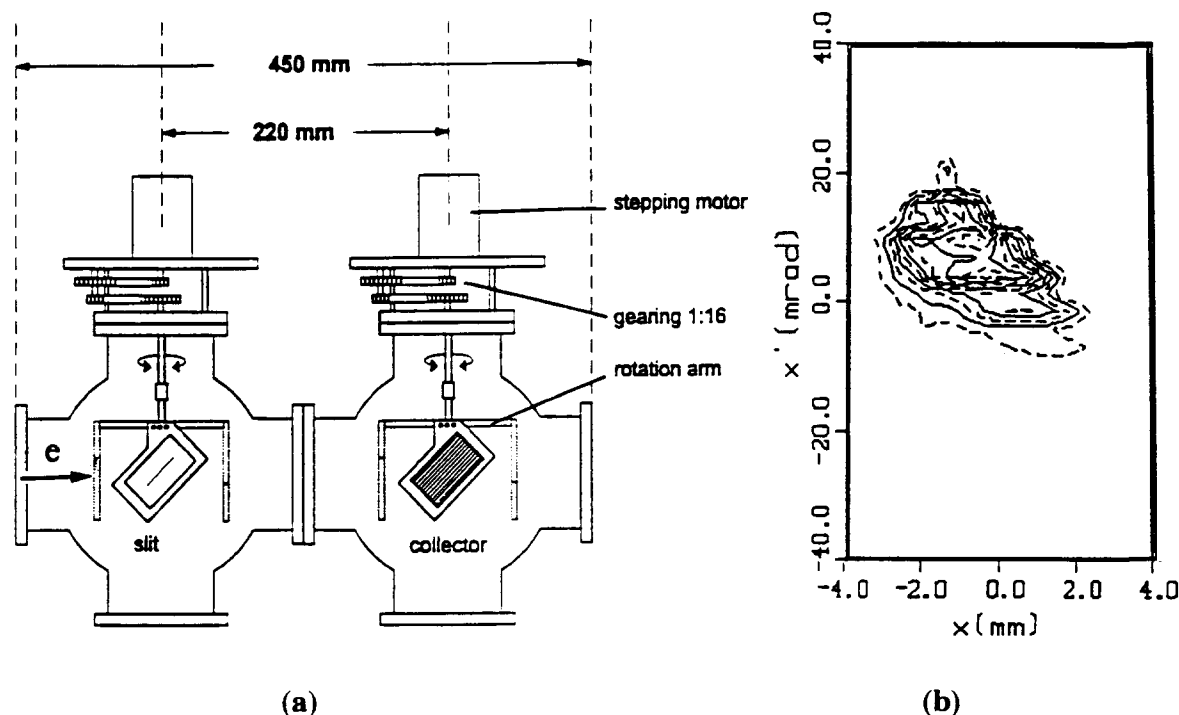

FIGURE 3. a) The apparatus used for the emittance measurements. The slit, on the left (0.2 mm), is scanned over the beam diameter, and for each position the angular spread is measured on the strip detector. b) A typical measurement: current $0.6 \mu\text{A}$, electron energy 200 eV, extraction nozzle 0.8 mm. The normalized emittance is $\epsilon_n = 0.6 \pi \text{ mm mrad}$.

A careful analysis of the measurements is currently carried out[8]. From a first inspection, the data do not show any monotonic variation as a function of any parameter. However, we estimate that the emittance has no reason to increase with current as far as the perveance ($I/V_e^{3/2} \approx 10^{-7}$) is conserved. Here, I is the beam current (Amp) and V_e the electron energy (Volts).

5. PRESENT STATUS AND FURTHER DEVELOPMENT

At present, we perform electron energy analysis experiments to determine the beam's energy spread. The experimental set-up consists basically of a spherical 90° electrostatic deviator. To increase the resolution of the instrument, the beam is decelerated to about 10 eV just before entering the deviator. The entrance slit is 0.17 mm. Due to the imperfect shielding against the earth's magnetic field we further reaccelerate the beam until it reaches a channeltron detector. For testing purposes we have used Ar as a target gas because in this case the spectrum is known and simple. The currently obtained resolution of 0.5 eV is enough to resolve the main features of the non-thermalized spectrum emerging from the reaction (1)[7].

At the same time, under preparation is the most important modification to the actual configuration of the source namely its operation with the magnetic field parallel to the extraction direction. This way we expect to extract a higher percentage of produced electrons for a given pressure and thus to operate the source at the trouble-free low

pressure regime. The electrons however will be longitudinally polarized. Their spin is made transverse by a 90° electrostatic deviator and the polarization is measured using a vertical scattering plane. Our new turnable Mott polarimeter, capable of carrying out polarization measurements at any scattering plane, has just been tested and it is actually calibrated.

ACKNOWLEDGMENTS

It is a pleasure for the authors to acknowledge the excellent technical assistance of Pierre Julou and Frederic Barjot. Thanks are also to Max Planck Institute at Heidelberg for the loan of the emittance measuring device.

REFERENCES

1. Sinclair C. K., *J. Phys. (Paris)* **46** C2-669, (1985); Anderson et. al., *Proceedings of the Forth European Particle Accelerator Conference (EPAC)*, **2**, 1483, (1994)
2. Rutherford G. H., Ratliff J. M., Lynn J. G., Dunning F. B. and Walters G. K., *Rev. Sci. Instrum.*, **61**, 1460-1463, (1990).
3. Arianer J., Cohen S., Essabaa S., Frascaria R. and Zerhouni O., *Proceedings of the Forth European Particle Accelerator Conference (EPAC)*, **2**, 1486, (1994)
4. Aminoff C. G., Larat C., Leduc M. and Laloe F., *Rev. Phys. Appl.* **24**, 827-832, (1989); Aminoff C. G., Essabaa S., Brissaud I. and Arianer J., *Optics Commun.* **86**, 99-105, (1991).
5. Essabaa S., Schearer L. D., Arianer J., Brissaud I., Humblot H. and Zerhouni O., *Nuclear Instr. and Methods A* , **344**, 315-318, (1994).
6. Arianer J., Brissaud I., Essabaa S., Humblot H. and Zerhouni O., *Nuclear Instr. and Methods A* , **337**, 1-2, (1993).
7. Le Nadan A., Le Coz G. and Tuffin F., *J. Phys.(Paris)* **50**, 387-395, (1989).
8. Arianer J., Cohen S., Essabaa S., Frascaria R., Schiebler H. and Zerhouni O., in preparation.