

СООБЩЕНИЯ
ОБЪЕДИНЕННОГО
ИНСТИТУТА
ЯДЕРНЫХ
ИССЛЕДОВАНИЙ

Дубна

LL

CERN LIBRARIES, GENEVA



SCAN-9507012

SW 9528

E8-95-65

A.M.Baldin, N.N.Agapov, V.A.Belushkin, E.I.D'yachkov,
H.G.Khodzhibagiyan, A.D.Kovalenko, G.L.Kuznetsov,
E.A.Matyushevsky, A.A.Smirnov, A.K.Sukhanova

CRYOGENICS
OF THE NEW SUPERCONDUCTING
ACCELERATOR NUCLOTRON.

INTRODUCTION

The Nuclotron [1, 2, 3] is intended to accelerate nuclei and heavy ions of all elements up to uranium. The maximum design energy of particles with the charge to mass ratio $Z/A = 1/2$ is 6 GeV per nucleon. A high (up to 1 Hz) frequency of accelerating cycles at the Nuclotron offers wide possibilities of using it as a booster also. The ring of the Nuclotron comprises 96 dipole magnets 1.5 m long, 64 quadrupole lenses 0.4 m long, 28 multipole correctors 0.31 m long with 3 or 4 types of coils in each, twelve 6 kA helium-cooled main current leads, 234 leads of 100 A current for correcting coils and special-purpose magnets, 32 special units of beam injection, acceleration, diagnostics, and extraction, and also about 600 sensors of cryogenic temperatures.

CRYOGENICS OF THE RING

The Nuclotron magnetic system is based on a magnet of the "Dubna" type [4, 5]. That is a pulsed SC magnet with a "cold" iron yoke and a hollow superconductor winding (see Fig. 1). The cryogenic performances of the magnets are presented in Table 1. The magnet is fastened in a

Table 1. Cryogenic performances of the magnets

	DIPOLE	QUADRUPOLE
Mass, kg	500	200
Length of SC cable in winding, m	62	24
Dynamic heat releases at $\dot{B}=2$ T/s, $B_{min}=0$, $B_{max}=2$ T, and $f=0.5$ Hz, W	21	12
Static heat releases (at zero current), W	6.6	5.8
Helium pressure difference between headers when magnets run at indicated ramp rate and $x_0=0$, $x_2=0.9$, kPa	20	20

vacuum shell of the cryostat $\varnothing 540$ mm by 8 suspension parts of stainless steel. A nitrogen shield $\varnothing 490$ mm covered with 20 layers of superinsulation is placed in the insulation vacuum space between the magnet and the vacuum shell. The supply and return helium headers, which the magnets

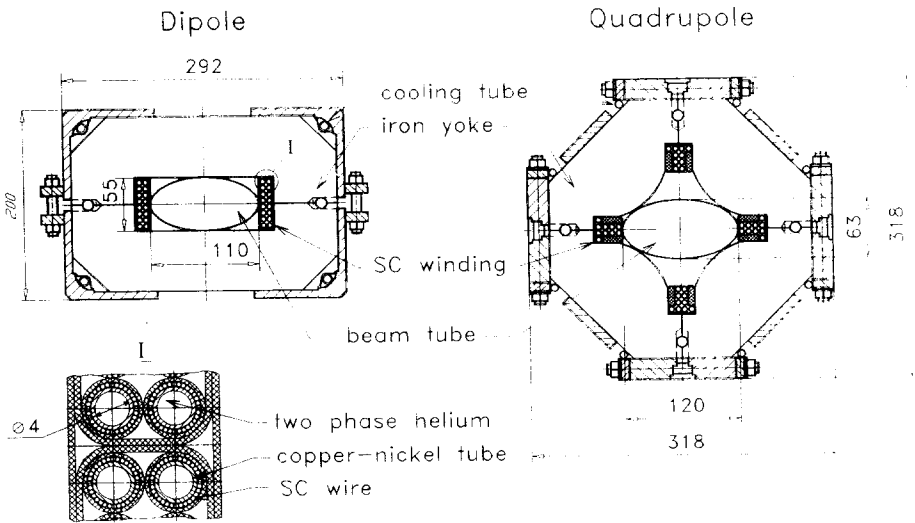

Figure 1. The cross sections of the dipole and quadrupole magnets

of the accelerator half-ring are connected in parallel with, are placed inside the nitrogen shield (see Figs. 2 and 3). The internal diameters of the supply and return headers are 36 mm and 52 mm, respectively. The cooling of the magnets is performed by a two-phase helium flow. The mass vapour content of helium varies from 0 at the inlet of the magnet to 0.9 at its outlet. Helium in the supply header of each half-ring is kept in a liquid state by means of a phase separator, a main subcooler, and a large number of small subcoolers. The temperature sensors are placed at the helium inlet and outlet of the winding and also at the helium outlet of the iron yoke of each magnet.

Figure 4 presents the values of heat load for the Nuclotron at 4.5 K versus the repetition frequency of accelerating cycles. These data have been obtained from the measured values of heat releases in individual components of the magnetic system. In addition, about 4.44 g/s of liquid helium are needed to cool the twelve 6 kA current leads.

CRYOGENIC SUPPLY SYSTEM

The cryogenic supply system [6] is based on three refrigerators/liquefiers of a nominal capacity of 1600 W at 4.5 K made by the NPO "GELYMASH".

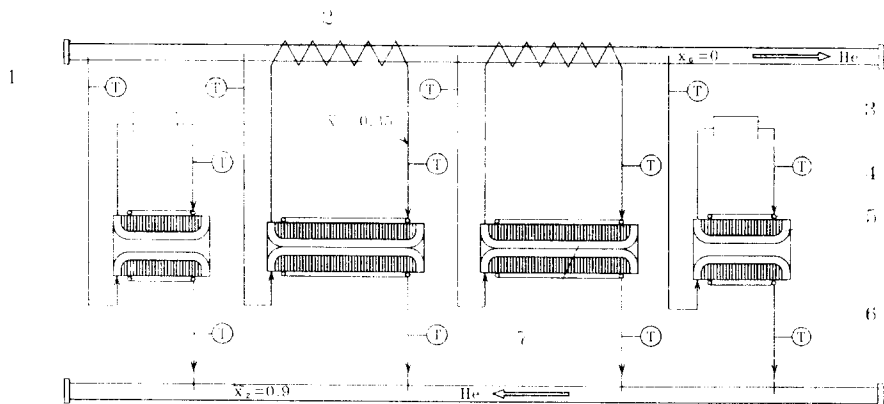

Figure 2. Flow diagram of the magnets. 1 – supply header; 2 – small subcooler; 3 – corrector or special element for beam extraction and diagnostics; 4 – tube for cooling the iron yoke; 5 – quadrupole winding; 6 – return header; 7 – dipole winding; T – thermometer; x_1 , x_2 – average mass vapour content in the helium flow at the outlet of the winding and the yoke, respectively; x_0 – mass vapour content in the supply header

Two refrigerators are connected each to a half-ring, respectively (see Fig. 3). The third one is aimed to run in the liquefaction mode with liquid helium fed to any refrigerator in the case of its failure or the Nuclotron operation at a maximum frequency of accelerating cycles. The refrigerator includes three turboexpanders T1, T2, T3, a liquid nitrogen bath, double- and triple-flow heat exchangers, wet turboexpander T4, and a liquid helium receiver with a volume of 1000 L. The nominal pressure of compressed helium at the entrance of the refrigerator is 2.5 MPa. The pressure in the liquid helium receiver is about 0.13 MPa. The basis of the compressor system is a screw compressor [7] of a 5040 m³/h capacity manufactured at the joint-stock company “NIFURBOCOMPRESSOR”. Three piston compressors with a capacity of 1200 m³/h each and four piston compressors of a 900 m³/h capacity each are used for step-by-step variation of the compressed helium flow and its redundancy. Gaseous helium is stored in 10 vessels of a 20 m³ capacity each with an operating pressure of 3 MPa.

Figure 5 shows the characteristics of the refrigerator/liquefier in the “mixed” operation mode: refrigeration and liquefaction simultaneously.

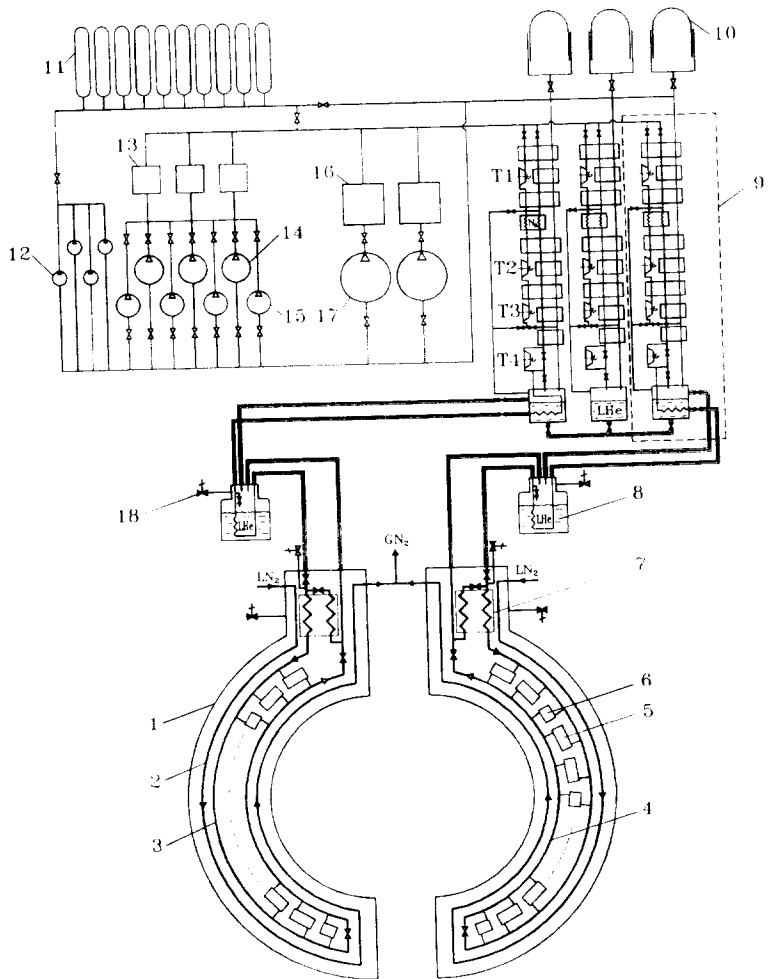

Figure 3. General scheme of the Nuclotron cryogenics. 1 - vacuum shell; 2 - heat shield; 3 - supply header; 4 - return header; 5 - dipole magnet; 6 - quadrupole magnet; 7 - main subcooler; 8 - phase separator; 9 - refrigerator; 10 - gas bag; 11 - storage vessel; 12, 14, 15, 17 - compressors; 13, 16 - purifiers; 18 - safety valve

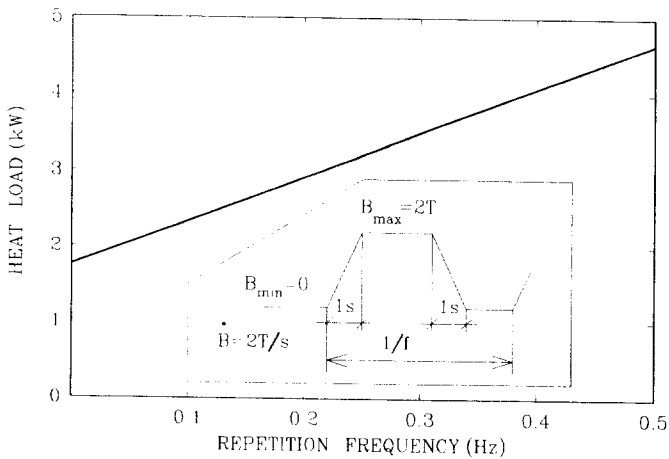

Figure 4. Heat load for the Nuclotron at 4.5 K versus the repetition frequency of accelerating cycles

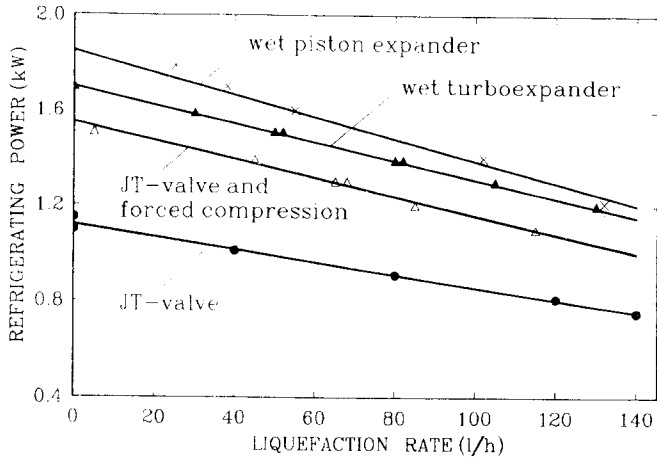

Figure 5. Characteristics of the refrigerator/liquefier

TEST RESULTS

The first test run of cooling [6] of the 80-ton magnetic system of the Nuclotron was held on March 17-26, 1993. Four runs of a total duration of 1000 hours were carried out from March 1993 to March 1994. The magnetic system cooldown time was varied from 103 to 126 hours and determined by given cooldown rate. The investigation of the accelerator systems with a gradual increase of stored energy in the magnetic system, particle acceleration and irradiation of the targets were performed in the runs. In the fourth run the value of the magnetic field was increased up to 1 T that is equal to 50% of the maximum design value. In this run deuterons were accelerated up to an energy of 3.5 GeV per nucleon, and three collaborations of physicists carried out their investigations using the internal target of the Nuclotron. The cooling of the magnets was stable. No flow rate oscillations were observed in the parallel cooling channels. However, there were quenches in some units of the magnetic system when an excessively small helium flow through the magnets or helium vapours in the supply header were initiated. So, quenches in the SC windings of the lenses with correctors were the result of decreasing the pressure difference below 15 kPa between the supply and return headers or incomplete immersion of the heat exchanger of the separator into liquid helium (the liquid helium level in the separator was less than 50%). These units have the largest value of static heat releases (about 14 W) which is due to heat releases through the current leads of the multipole coils.

The next run of the Nuclotron is planned on July 1994. Studies with heavy ion beams are included in its schedule.

References

- [1] Baldin, A.M. and Kovalenko, A.D., The status of the Dubna relativistic heavy ion accelerator facility (abstract), CERN bulletin (1993) 14/93:4
- [2] Baldin, A.M. et al., Nuclotron status report, IEEE Trans. on Nucl. Sci. (1983) NS-30 4:3247-3249

- [3] Baldin, A.M., Status and physics programme at Nuclotron, JINR Comm. (1992) E1-92-487
- [4] Smirnov, A.A. et al., A pulsed superconducting dipole magnet for the Nuclotron, Journal de Physique (1984) C1 45:279-282
- [5] Khodzhibagiyan, H.G. and Smirnov, A.A., The concept of a superconducting magnet system for the Nuclotron, Proc. of the Twelfth Int. Cryog. Eng. Conf. (1988) 841-844
- [6] Baldin, A.M. et al., Cryogenic system of the Nuclotron — a new superconducting synchrotron, Adv. Cryog. Eng. (to be published) 39 501-508
- [7] Agapov, N.N. et al., Test results of the screw oil-filled compressor "Cascade-80/25", JINR Comm. (1990) 8-90-304

Received by Publishing Department
on February 17, 1995.

Принимается подписка на препринты, сообщения Объединенного института ядерных исследований и «Краткие сообщения ОИЯИ».

Установлена следующая стоимость подписки на 12 месяцев на издания ОИЯИ, включая пересылку, по отдельным тематическим категориям:

Индекс	Тематика	Цена подписки на год
1.	Экспериментальная физика высоких энергий	22600 р.
2.	Теоретическая физика высоких энергий	59200 р.
3.	Экспериментальная нейтронная физика	7800 р.
4.	Теоретическая физика низких энергий	23400 р.
5.	Математика	14800 р.
6.	Ядерная спектроскопия и радиохимия	12000 р.
7.	Физика тяжелых ионов	2200 р.
8.	Криогеника	1400 р.
9.	Ускорители	12200 р.
10.	Автоматизация обработки экспериментальных данных	12200 р.
11.	Вычислительная математика и техника	14300 р.
12.	Химия	1200 р.
13.	Техника физического эксперимента	21300 р.
14.	Исследования твердых тел и жидкостей ядерными методами	7200 р.
15.	Экспериментальная физика ядерных реакций при низких энергиях	2600 р.
16.	Дозиметрия и физика защиты	2200 р.
17.	Теория конденсированного состояния	12200 р.
18.	Использование результатов и методов фундаментальных физических исследований в смежных областях науки и техники	1800 р.
19.	Биофизика	1800 р.
	«Краткие сообщения ОИЯИ» (5—6 выпусков)	15000 р.

Подписка может быть оформлена с любого месяца года.

Организациям и лицам, заинтересованным в получении изданий ОИЯИ, следует перевести (или отправить по почте) необходимую сумму на расчетный счет 000608905 Дубненского филиала ММКБ, г.Дубна Московской области, п/инд. 141980 МФО 211844, указав: «За подписку на издания ОИЯИ».

Во избежание недоразумений необходимо уведомить издательский отдел о произведенной оплате и вернуть «Карточку подписчика», отметив в ней номера и названия тематических категорий, на которые оформляется подписка, по адресу:

141980 г. Дубна Московской обл.
ул. Жолио Кюри, 6
ОИЯИ, издательский отдел

Балдин А.М. и др.

E8-95-65

Криогеника нового сверхпроводящего ускорителя нуклотрон.
Первый год эксплуатации

Сверхпроводящий синхротрон Лаборатории высоких энергий Объединенного института ядерных исследований в Дубне был запущен в марте 1993 года. С марта 1993 г. по март 1994 г. было проведено 4 сеанса работы ускорителя общей продолжительностью более 1000 часов. Охлаждение магнитной системы ускорителя длиной 251,5 м осуществлялось с помощью двух гелиевых рефрижераторов холодопроизводительностью по 1,6 кВт при 4,5 К. Магниты криостатировались потоком двухфазного гелия. Все 160 магнитов подключены параллельно к питающим и отводящим гелиевым коллекторам. Приведены описание криогенной системы нуклотрона и ее эксплуатационные характеристики.

Работа выполнена в Лаборатории высоких энергий ОИЯИ.

Сообщение Объединенного института ядерных исследований. Дубна, 1995

Baldin A.M. et al.

E8-95-65

Cryogenics of the New Superconducting Accelerator Nuclotron.
The First Year under Operation

The 6 GeV superconducting synchrotron was commissioned in March 1993 at the Laboratory of High Energies of the Joint Institute for Nuclear Research in Dubna. Four runs of a total duration about 1000 hours were provided from March 1993 to March 1994. The cooling of the accelerator magnetic system of 250 meters long was performed by two helium refrigerators with a capacity of 1.6 kW at 4.5 K each. The magnets were refrigerated by a two-phase helium flow. All 160 magnets are connected in parallel to the supply and return helium headers. The description and operational characteristics of the Nuclotron cryogenic system are presented.

The investigation has been performed at the Laboratory of High Energies, JINR.

Communication of the Joint Institute for Nuclear Research. Dubna, 1995

Макет Т.Е.Попеко

Подписано в печать 27.03.95
Формат 60×90/16. Офсетная печать. Уч.-изд.листов 1,09
Тираж 260. Заказ 48078. Цена 654 р.

Издательский отдел Объединенного института ядерных исследований
Дубна Московской области