

BB

CERN LIBRARIES, GENEVA

E6-94-382



SCAN-9503110

SW95M

MEASUREMENT OF THE INDUCED
PSEUDOSCALAR FORM FACTOR
IN THE CAPTURE OF POLARIZED MUONS
BY Si NUCLEI*

Submitted to «Nuclear Physics A»

*The work was supported in part by the Russian Foundation
for Fundamental Research

V.Brudanin, V.Egorov, T.Filipova, A.Kachalkin, V.Kovalenko, A.Salamatin,
Yu.Shitov, I.Stekl, S.Vassiliev, V.Vorobel, Ts.Vylov, I.Yutlandov, Sh.Zaparov
Joint Institute for Nuclear Research, 141980 Dubna, Russia

J.Deutsch, R.Pricels, L.Grenacs
Universite Catholique de Louvain, B-1348 Louvain-la-Neuve, Belgium

J.Rak
Institute of Nuclear Physics, 25068 Rez, Czech Republic

Ch.Briancon
Centre de Spectrometrie Nucleaire et de Spectrometrie de Masse,
91405 Orsay, France

1 Introduction

The standard weak interaction model describing semileptonic processes such as β -decay, e - and μ -capture, predicts the following form of the axial weak current at the nucleon-level:

$$G_{\text{had}} \langle n | g_A(q^2) \cdot \gamma_5 \gamma_4 + g_P(q^2) \cdot \frac{i q_4 \gamma_5}{m} + g_T(q^2) \cdot \frac{q_0 \sigma_{\alpha\beta} \gamma_5}{2M_p} | p \rangle \quad (1)$$

where the second and the third terms are *induced* by the structure of the nucleon and depend on the momentum-transfer q [1]. The value of the axial form factor $g_A(0)$ is measured in the widely investigated process of neutron β -decay: $g_A(0) = -1.257 \pm 0.003$ [2], whereas the influence of the induced pseudoscalar form factor g_P becomes significant only at $q^2 \gg m_\pi^2$ and thus can be observed only in μ -capture. If we assume that the induced pseudoscalar coupling in μ -capture is predominantly due to the capture of the muon by a virtual pion, then the well-known Goldberger-Treiman prediction of g_P (using the *Partial Conservation of the Axial Current - PCAC*) can be formulated[3, 4]:

$$g_P(q^2=0.88m_\mu^2) = g_{\pi NN}(-m_\pi^2) \cdot f_\pi \cdot \frac{m_\pi^2 + m_\mu^2}{q^2 + m_\pi^2} \simeq g_A(q^2) \cdot \frac{2M m_\mu}{q^2 + m_\pi^2} \simeq 7 g_A(q^2) \simeq -8.7 \quad (2)$$

which is in good agreement with the average mean value of g_P measured for μ -capture in hydrogen[5]:

$$g_P^{\text{exp}}(0.88m_\mu^2) = -8.7 \pm 1.9 \quad (3)$$

The g_T term is *zero* if one accepts invariance under G -parity transformation.

In case of μ -capture by a *nucleus* the values of all form factors could be influenced by the nuclear hadronic medium. This modification is induced by that of $g_{\pi NN}$, f_π and the mass of the virtual pion m_π , and therefore should be very sensitive to the parameters of nuclear matter, such as "nuclear temperature", pion density, etc. Some estimations[8]-[12] predict a significant quenching of g_A and g_P for "infinite" nuclear medium:

$$g_A^* \approx 0.75 g_A \quad (4)$$

$$g_P^* \approx 0.33 g_P \quad (5)$$

Does such quenching really exist? This open question could be answered by the investigation of semileptonic processes in *nuclei of wide mass band*. Today sparse and discrepant informations on g_A in nuclei[13]-[15] indicate that the quenching rather *does not exist*. The same conclusion may be reached on g_P in the *ordinary* μ -capture (*OMC*) in carbon:

$$g_P^{\text{exp}}(0.73m_\mu^2) / g_A^{\text{exp}}(0.73m_\mu^2) = 9.0 \pm 1.7 \quad [48]$$

$$= 9.6 \pm \frac{2.4}{2.7} \quad [17] \quad (6)$$

$$= 10.1 \pm \frac{2.4}{2.6} \quad [18]$$

On the other hand, the experiments[19]-[23] on the *radiative* μ -capture (*RMIC*) indicate the strong dependence of g_P on nuclear mass. Unfortunately, *RMIC* data are nuclear model

²This value was obtained assuming for the $\lambda_{\text{ortho-param}}$ transition rate the experimental value of $(4.1 \pm 1.4) \cdot 10^4$ as given in [5]. It was, however, pointed out by M.Easinoff[6] that the use of the theoretical one ($\lambda_{\text{ortho-param}} = 7.1 \cdot 10^4$; Ref.[7]) would result in $g_P^{\text{exp}}(0.88m_\mu^2) = -3.8$

dependent and so this conclusion may not be sufficiently reliable; some alternatif approaches conclude even to no sizeable modification of g_P at all [24].

As it can be seen from this discussion, it would be very important now to measure g_A and (especially) g_P in *OMC* for targets with $A > 12$. Such experiments might provide also informations on nuclear temperature and pion mass and density dependance which is important for astrophysics.

2 The method of angular correlation

The most sensitive tool to obtain the g_P/g_A -value are experiments involving angular correlations in *OMC*.

Consider the capture of polarized muon by a nucleus (A, Z) . This process produces the excited daughter nucleus $(A, Z - 1)$ which has very significant recoil caused by the muonic neutrino emission ($E_\nu \simeq m_\mu \simeq 100 \text{ MeV}$). Within the lifetime τ a nuclear excited state could deexcite by γ -transition(s) with energy E_γ and multipolarity L :

$$\begin{aligned} \mu^- + (A, Z)_i &\xrightarrow{\mu C} (A, Z - 1)_i^* + \nu_\mu \\ &\xrightarrow{\tau} (A, Z - 1)_l + \gamma_{E,L} \end{aligned} \quad (7)$$

The angular correlation between the residual muon polarization \vec{P} and momenta of neutrino \vec{q} and γ -quantum \vec{k} in *allowed* ordinary μ -capture[25]-[28] can be written as

$$W = 1 + (\alpha + \frac{2}{3} \cdot c_1) \cdot (\vec{P} \cdot \vec{k}) \cdot (\vec{k} \cdot \vec{q}) + (a_2 + b_2 \cdot (\vec{P} \cdot \vec{k}) \cdot (\vec{k} \cdot \vec{q})) \cdot P_2(\vec{k} \cdot \vec{q}) \quad (8)$$

where P_2 is a Legendre polynomial and α , a_2 , b_2 , c_1 are the correlation coefficients. The coefficient α gives the asymmetry of the neutrino emission; the other ones depend on the γ -multipolarity and describe the anisotropy of γ -radiation caused by particular *polarization* of the recoil nucleus after the capture of *polarized* muon with the emission of *polarized* neutrino).

Using the multipole analysis [29, 30, 31] based on the total transferred angular momentum u , it is possible to describe the process of muon capture by means of the nuclear amplitudes $M_u(u+1)$ and $M_u(-u)$ which are the functions of the reduced nuclear matrix elements $[k\omega u]$, $[k\omega u p]$ and form factors $g_A(q^2)$, $g_V(q^2)$, $g_P(q^2)$, $g_M(q^2)$, $g_S(q^2)$ and $g_T(q^2)$ (and/or of their linear combinations G_A , G_P) :

$$G_A = g_A - \{g_V + g_M\} \cdot \frac{E_\nu}{2M} \quad (9)$$

$$G_P = \{g_P - g_A - g_T - g_V - g_M\} \cdot \frac{E_\nu}{2M} \quad (10)$$

In case of an allowed $0^+ \rightarrow 1^+$ transition ($u=1$) these amplitudes are :

$$M_1(-1) = \sqrt{\frac{2}{3}} \left\{ \left(\frac{1}{3} G_P - G_A \right) \cdot [101] + G_P \frac{\sqrt{2}}{3} \cdot [121] - \frac{g_A}{M} \cdot [011p] + \frac{g_V}{M} \sqrt{\frac{2}{3}} \cdot [111p] \right\}; \quad (11)$$

$$M_1(2) = \sqrt{\frac{2}{3}} \left\{ \left(G_A - \frac{2}{3} G_P \right) \cdot [121] - G_P \frac{\sqrt{2}}{3} \cdot [101] + \frac{g_A}{M} \sqrt{2} \cdot [011p] + \frac{g_V}{M} \sqrt{\frac{2}{3}} \cdot [111p] \right\}. \quad (12)$$

Assuming the absence of CP -violation, all the correlation coefficients in (8) could be expressed as functions of a unique parameter x which is the ratio

$$x \equiv M_1(2)/M_1(-1) , \quad (13)$$

in the following way :

$$\alpha = \frac{1}{3} \cdot \frac{1 + 4\sqrt{2}x - x^2}{1 + x^2} ; \quad (14)$$

$$c_1 = Q_2(I_f^\pi \rightarrow I_0^\pi, L) \cdot \frac{1 - x/\sqrt{2} - x^2}{1 + x^2} ; \quad (15)$$

$$a_2 = Q_2(I_f^\pi \rightarrow I_0^\pi, L) \cdot \frac{\sqrt{2}x - x^2/2}{1 + x^2} ; \quad (16)$$

$$b_2 = Q_2(I_f^\pi \rightarrow I_0^\pi, L) \cdot \frac{\frac{3}{2}x^2}{1 + x^2} . \quad (17)$$

Here, the factor Q_2 depends on spin sequence ($I_f^\pi \rightarrow I_0^\pi$) and the multipolarity L of γ -transition :

$$\begin{aligned} Q_2(1^\pi \rightarrow 0^\pi ; \quad MI) &= 1 ; \\ Q_2(1^\pi \rightarrow 2^\pi ; \quad MI + E2) &= \frac{1}{10} \cdot (1 - 6\sqrt{5} \cdot \delta + 5\delta^2)/(1 + \delta^2) , \end{aligned} \quad (18)$$

where δ is the ratio of $E2$ and MI components in the γ -transition.

The main objectif of the experiment is the determination of the parameter x which describes the alignment of the nuclear state produced in the μ -capture process. g_F/g_A can be extracted from the measured value of x in a nuclear model independent way only using the so-called Fujii-Primakoff approximation (FPA) [1, 32, 33], i.e. neglecting in the expressions (11) and (12) all matrix elements other than the leading one [10]. One obtains :

$$\frac{3x}{x + \sqrt{2}} = \frac{g_F(q^2) - g_A(q^2) - g_T(q^2) - g_V(q^2) - g_M(q^2)}{(2M_N/q \cdot g_A(q^2) - g_V(q^2) - g_M(q^2))} . \quad (19)$$

For example, let us consider the capture of muons by ^{28}Si which was already investigated by G.H.Miller *et al.* [34]. Taking into account that the value of the transferred momentum q^2 in this case :

$$q^2 = m_\mu^2 \cdot \left(\frac{2E_\nu}{m_\mu} - 1 \right) \approx 0.848 m_\mu^2 \quad (20)$$

and using the following values [2, 10, 33, 35] of $g_i(q^2)$:

$$\begin{aligned} g_V(0) &= +1 && \text{(from } CVC) \\ g_M(0) &= +3.706 && \text{(from } CVC) \\ g_A(0) &= -1.257 \pm 0.003 && \text{(from neutron } \beta\text{-decay)} \\ g_V(0.848m_\mu^2)/g_V(0) &\approx +0.978 \\ g_M(0.848m_\mu^2)/g_M(0) &\approx +0.970 \\ g_A(0.848m_\mu^2)/g_A(0) &\approx +0.981 \end{aligned} \quad (21)$$

one obtains :

$$\frac{g_F(0.848m_\mu^2) - g_T(0.848m_\mu^2)}{g_A(0.848m_\mu^2)} = \frac{68.37x}{x + \sqrt{2}} - 2.71 . \quad (22)$$

If we suppose now that $g_T = 0$, we obtain finally :

$$g_P/g_A = \frac{68.37x}{x + \sqrt{2}} - 2.71 \quad (23)$$

The simple and nuclear model independent expression (23) is not longer valid if one takes into account the remaining matrix elements ($[121]$, $[011p]$ and $[111p]$) and one has to evaluate the ratio of these matrix elements to the dominant $[101]$ -one. We are aware of two approaches to this problem: one of S.Ciechanowicz (CA) (ref.[36]) and one of R.Parthasarathy and V.N.Sridhar (refs.[37, 38]). Unfortunately the various correlation coefficients (14) (17) produced by the authors of refs.[37, 38], in their most complete treatment (Model II), are inconsistent as they do not correspond, as they should, to common values of the parameter. Awaiting a clarification of this inconsistency, we use in this paper exclusively the evaluation of ref.[36] (CA).

The angular correlations described in (8) can be investigated with the method proposed in Ref.[39]. The method consists in the precise measurement of the specific shape of γ -lines corresponding to the decay of short-lived excited states of the recoil nuclei. The non detectable momentum \vec{q} of the neutrino can be inferred from the momentum of the recoiling excited nucleus and if the latter deexcites fast enough it can transmit its recoil information through the Doppler shift of the subsequent γ -emission. The residual muon polarization \vec{P} could be measured independently with the μSR -technique, the momentum \vec{k} is simply determined by the set-up geometry, the angle between \vec{k} and \vec{q} can be deduced from the value of the γ -quantum Doppler shift.

In case of a Si target the lines of 1229 and 2171 keV which are emitted in the decay of the short-lived (1^+) level of the daughter nucleus ^{28}Al have an asymmetric shape; the first one has, in addition, an obvious two-hump shape. The slope is caused by the fixed neutrino helicity and depends on the g_A -value, whereas the dip at the line center is caused by the alignment of the recoil nucleus and could be explained by the presence of g_P .

Such experiments are not easy. A pioneering one[34] achieved in 1972 reached a rather wide range of solutions for the parameter x . Moreover the various correlation coefficients of the γ -transition were inconsistent.

To improve the accuracy, various factors should be included into the data analysis in addition to the ones considered by the authors of ref.[34]. One of the main ones is the slowing-down of the daughter nucleus before the emission of the γ -ray. Because of recoil after neutrino emission, the γ -energy is, in reality :

$$E_\gamma(t) = E_\gamma^0 \cdot (1 - V(t) \cdot (\vec{k} \cdot \vec{q})) \quad (24)$$

where E_γ^0 is the transition energy in rest, and V is the velocity of nucleus at the moment of γ -transition. Just after μ -capture (at $t = 0$) this velocity is

$$V(0) = \left(1 + 2 \cdot \frac{(M_i - M_f) + (m_\mu - m_e) - E_{1S}}{M_f} \right)^{1/2} - 1 \quad (25)$$

(here, $M_{i,f}$ represents the mass of initial and final neutral atoms, respectively, and E_{1S} is the muon binding energy at the 1S-shell in the muonic atom of a target). Because of the scattering and slowing-down of the recoiling nucleus V ($t > 0$) changes its magnitude. The subsequent Doppler shift reduction depends on the level lifetime τ and can be estimated using the *LSS*-method [40] [45].

Both the above mentioned effects (the neutrino emission correlated with the muon residual polarization and the recoil slowing-down), as well as the finite target-detector geometry and detector response function, produce the specific shape of the measured γ -lines. In order to understand the relative contribution of all these factors and to choose the most appropriate target, we simulated the relevant γ -lines for carbon, magnesium, silicon and sulfur solid targets. Analysis of the simulation results showed that slowing-down in solid targets plays a very significant role if the level lifetime τ is more than 10-20 fs and makes the measurement impossible at $\tau \geq 100$ fs. At the other hand, if $\tau \leq 100$ fs, the slowing-down process modifies the γ -line mainly in a symmetric way (even momenta), whereas the g_F/g_A -ratio induces also a line asymmetry (odd momentum). Both values (g_F/g_A and τ) can consequently be determined from the experimental line shape.

Finally, taking into account the yield of γ -rays [46, 47, 48] and the muon de-polarization in different substances [49], a single cristal of natural silicon (abundance of ^{28}Si is 92.2%) has been chosen as the appropriate target. Some of the excited levels of ^{28}Al populated in muon capture by ^{28}Si and relevant to this experiment are shown on Fig. 1. The 2202 keV level ($I^\pi = 1^+$) is short-lived enough ($\tau \approx 65$ fs [50]) and decays by two γ -transitions: either by a $M1$ ($1^+ \rightarrow 0^+$) -transition of 1229 keV, or by a mixed $M1+E2$ ($1^+ \rightarrow 2^+$) -transition of 2171 keV. Both γ -lines are good candidates for the analysis.

3 Experimental procedure

The experimental set-up using the secondary μ^- -beam of the JINR Phasotron [51] is shown on Fig.2. A more detailed description of it can be found in ref. [52]. The muons with a momentum of 125 ± 6 MeV/c and a longitudinal polarization of about -0.7 cross three plastic scintillator counters (#1..3) and stop in the silicon target ($\approx 65 \times 25$ mm). As the distance between the proton-beam target and the muon target is very long (22 m), the admixture of pions do not exceed 0.5%; the content of electrons is 9%. To reduce the beam energy a graphite moderator of 9 cm thickness is used. As a result, a 1 μA proton beam produces about 10^4 μ -stops per second in the target.

Two high volume (205 cm^3) HP Ge detectors detect the γ -quanta. They are installed on a platform which can be moved along the beam axis, so that it is possible to change the angle ($\vec{\mathbf{P}} \cdot \vec{\mathbf{k}}$) from 60° in "Backward" position up to 120° in "Forward" position. In a preliminary test run it was found that muon decay electrons with the energy up to 50 MeV caused the saturation of the pre-amplifiers (especially with cold FET) and distorted the response function of the γ -spectrometer. To reduce this distortion, the γ -detectors were shielded with "anti-Michel" plastic scintillator counters (#5..6) which produce "veto" signals long enough as to enable electronic restoration (100 μs).

Fast electronics select the "single" incoming muons and open a gate of 2 μs delayed by 50 ns after the μ -stop in order to avoid the prompt radiation detection and reduce the uncorrelated background. Every hour the detectors are moved from "Backward" to "Forward" and vice versa. Twice per day an energy and resolution calibration is made with the standard ^{56}Co , ^{60}Co and ^{228}Th γ -sources.

4 Analysis of the results

The cumulative γ -spectrum shown on Fig.3 represents, for illustration, the sum of "Backward" and "Forward" spectra. Each of them in its turn is the sum of "good γ " measured by both Ge detectors during the 130 hours of total measuring time. The shifts in energy-calibration were monitored permanently and duly corrected for.

Several γ -lines of ^{28}Al have significant Doppler broadening, but only two lines were analysed carefully: the 1229 and 2171 keV ones, both originating from the 1^+ level at 2202 keV. As it was mentioned before, the specific shape of γ -lines is determined by many factors. They are:

- *The polarization of the beam and the de-polarization process in the target.* In our case the residual muon polarization was measured by means of μSR -method. We get $\overline{P} = (-10.25 \pm 0.25)\%$.
- *The relative beam-target-detector geometry.* It was measured carefully in both positions ("Backward" and "Forward"). The longitudinal distribution function of p -stops in the target was deduced from the " μ -stop range curve". The radial distribution is Gaussian corresponding to the beam cross-section ($FWHM_x = 6\text{ cm}$, $FWHM_y = 12\text{ cm}$).
- *The initial recoil velocity $[V(0)]$.* It can be calculated very precisely (Equ.25) from the energy conservation. It is possible because there is no any significant population of the level 2202 keV from the upper states [50] as shown by the absence of the corresponding γ -lines in our spectra.
- *The life time τ of the 2202 keV level.* We suppose it to be roughly known ($\tau = 65 \pm 35\text{ fs}$)[50] but consider it as a parameter to be determined in our fitting procedure.
- *The target density and its micro-structure.* Our target is a single cristal of natural silicon ($\rho = 2.33\text{ g/cm}^3$).
- *The angular correlation coefficients α , c_1 , a_2 , b_2 .* These coefficients are of course unknown: they are the main parameters to be determined in the experiment. Note that in the case of 2171 keV line they contain also the unknown ratio δ of the transition multipolarity mixture (Eqn.18).
- *The possible γ -feeding of the 2202 keV level from the upper states.* The most probable candidate for such feeding is 1^+ 3105 keV level, but the corresponding γ -line of 903 keV is not present in spectrum. So, the distortion of the investigated γ -lines through this effect may be neglected.
- *The population of the 2202 keV level in the $^{29}\text{Si}(\mu, \nu n)$ reaction.* There are only 4.67% of ^{29}Si in natural silicon, and from systematics its effective yield, relative to the main reaction, is not expected to exceed $\sim 10\%$ [46]. The recoil of daughter nucleus in this process is determined by the momenta of both the neutrino and neutron and so depends on the neutron energy which is not known with precision. The emission of each of these two particles would induce a flat "rectangular" broadening of the consequent γ -line, the simultaneous emission of both results in a "isosceles triangular" broadening which is the convolution of two rectangular components. Such a "triangular" addition

is a constant fraction ξ of both of the investigated lines; the value of this fraction ξ is unknown in principle and its effect will be considered below; the half-width Δ of the "triangle" could be roughly estimated from the analysis of similar triangular γ -lines of 1719, 2210 and 2941 keV which are present in the spectra due to the $^{28}\text{Si}(\mu, \nu n)$ reaction.

- *The shape of background.* Background lines should be the same in the "Forward" and "Backward" spectra and, therefore, could not distort the odd coefficients a and c_1 , whereas the values of the even coefficients a_2 and b_2 could be distorted significantly. Fortunately, the 2171 keV line has a constant flat background. The background of the second line (1229 keV) has a much more complicated structure (see Fig.4) and includes three more components:
 1. An asymmetric and slightly decreasing triangular bump with $E \geq 1204$ keV due to the reaction $^{74}\text{Ge}(n, n'\gamma_{1204})$ [53] caused in the Ge detectors itself by fast neutrons. The long right-side tail of this γ -line originates from the pile-up of γ -quanta and the recoil energy of Ge nuclei [54, 55] which are both detected by the same Ge-detector. The precise shape of this bump can be obtained from the analysis of the similar lines of 536 and 608 keV from ^{74}Ge , as well as the 1040 keV one from ^{70}Ge and the 691 keV one from ^{72}Ge . A similar bump (with a much longer tail) could be seen in π -capture experiments [56] where the neutrons are emitted with higher energy.
 2. A symmetrically broadened triangular 1222 keV γ -line emitted from the short-lived 3956 keV state of ^{27}Al populated in the $(\mu, \nu n)$ - reaction; this contribution could be estimated from the analysis of similar γ -lines at 1719, 2210 and 2941 keV.
 3. A "normal" (not broadened) 1238 keV γ -line emitted from the relatively long-lived 2058 keV state of ^{56}Fe populated in (n, n') reaction as well as in the β^+ decay of the long-lived ^{56}Co nuclei present in the surrounding activated materials.
- *The response function of the detection system.* It is a Gaussian with parameters obtained from non-broadened background lines at 1173, 1332 and 2614 keV, as well as from the lines of the additional external calibration sources. As a result, the average energy resolution ($FWHM$) at the energy 1229 keV (2171 keV) was found to be 2.99 keV (3.70 keV) for the detector "A" and 2.99 keV (4.00 keV) for the detector "B", respectively.

Taking into account the above factors, we calculated the value of χ^2 , comparing our spectra with the theoretically simulated lines. Several fits with different conditions were carried out using the standard "MINUIT" code. In each case all the fitted lines (1229 and/or 2171 keV, detected by the detector "A" and "B" in "Forward" and in "Backward" position) were simulated *simultaneously* by their corresponding theory, consequently the resulting value of χ^2 reflected the quality of the fit for all the spectra. The conditions of the fits and the results, with errors corresponding to the 67% CL, are listed and discussed below. The g_P/g_A ratios presented in the Tables are deduced from the corresponding x -values using ref.[36] (CA) and are given here for illustration only. Fits were performed introducing more and more realistic assumptions resulting of course in increased complexity. They are presented in sections 4.1 to 4.5; the treatment of 4.4 being the most realistic, it provides our final results.

4.1 1229 keV γ -line only; background linear with no structure.

As the first approximation, the line of 1229 keV was analysed assuming the absence of background lines in the 1215- 1236 keV energy region. This background was first subtracted from each of the four spectra and the position of the peak determined from the sum of the results. Parameters fitted were the following ones³:

- the γ -line area (4),
- the " x "-value (1).

The life-time τ of the 2202 keV level could not be used as free parameter and the results presented in Table 1 computed for fixed values of τ show a strong dependence on this value. Therefore additional information is required to precise x and g_P/g_A .

τ [fs]	x	g_P/g_A (CA)	χ^2	
			full	norm.
20	$+0.085 \pm 0.036$	-2.3 ± 1.3	168.8	0.692
30	$+0.137 \pm 0.039$	-0.5 ± 1.4	169.5	0.695
40	$+0.193 \pm 0.044$	$+1.4 \pm 1.4$	170.6	0.700
50	$+0.255 \pm 0.052$	$+3.4 \pm 1.6$	171.9	0.705
60	$+0.328 \pm 0.065$	$+5.5 \pm 1.8$	173.3	0.710
70	$+0.422 \pm 0.095$	$+8.0 \pm 2.4$	174.8	0.716
80	$+0.878 \pm 0.250$	$+17.3 \pm 4.2$	175.8	0.720

4.2 2171 keV γ -line only; background linear with no structure.

In order to constrain the τ -value, the 2171 keV line was analysed using the following free parameters :

- the γ -line area (4),
- the " x "-value (1).
- the 2202 keV level life-time τ (1).

The background and the peak position were determined as for the 1229 keV γ -line (cfr. 4.1). The $E2/M1$ mixture parameter δ is definitely unknown. The only and very rough limitation which could be deduced *a priori* from the systematics and from the level life-time is that this $1^+ \rightarrow 2^+$ γ -transition is fast enough, and therefore might be predominantly $M1$. The results for the δ -parameter fixed in the region from -0.2 up to $+1.2$ are shown in the Table 2.

³The number of free parameters for each contribution is shown in parentheses.

δ	τ [fs]	x	g_E/g_A (C/A)	χ^2	
				full	norm.
-0.20	50 ± 7	-0.980 ± 0.071	-9.2 ± 3.3	257.6	0.907
-0.10	60 ± 6	$+0.039 \pm 0.092$	-3.3 ± 3.6	261.5	0.921
0.00	63 ± 4	$+0.301 \pm 0.161$	$+1.8 \pm 1.7$	258.5	0.910
+0.10	51 ± 3	$+0.701 \pm 0.122$	$+11.2 \pm 8.4$	249.5	0.879
+0.20	45 ± 2	$+0.701 \pm 0.239$	$+11.2 \pm 1.7$	241.6	0.851
+0.10	33 ± 2	$+0.707 \pm 0.195$	$+11.3 \pm 3.8$	232.9	0.820
+0.60	27 ± 2	$+0.712 \pm 0.205$	$+11.1 \pm 3.9$	230.4	0.811
+0.80	26 ± 2	$+0.713 \pm 0.205$	$+11.1 \pm 3.9$	230.2	0.810
+1.00	28 ± 2	$+0.710 \pm 0.190$	$+11.3 \pm 3.7$	230.9	0.813
+1.20	31 ± 2	$+0.708 \pm 0.196$	$+11.3 \pm 3.8$	232.3	0.818

Unfortunately, it is impossible to extract the δ value with sufficient accuracy from the *2171 keV* line alone, but the strong correlation between δ and x on one hand, and the relatively weak correlation between δ and τ on other hand allows one to do it combining the data on both γ -lines as will be discussed in the following section.

4.3 Both the *1229* and the *2171 keV* γ -lines: background linear.

In the two separate fits discussed before we did not converge to a minimum if *all* the parameters, including τ and δ , were kept free: the *1229 keV* line is too sensitive to τ and x , the *2171 keV* line is less sensitive to x but depends on δ . In both cases there is no well-defined minimum on the χ^2 surface. In the joint analysis of both the *1229 keV* and the *2171 keV* lines, however, the minimum becomes deeper and can be easily located. After the determination of the backgrounds and the peak positions as discussed above, the following parameters remained free and were fitted:

- the γ -line areas (8),
- the “ x ”-value (1),
- the *2202 keV* level life-time τ (1),
- the *E2/M1* mixing ratio δ for the *2171 keV* γ -line (1).

We obtained the following result:

$$\begin{aligned}
 \delta &= +0.51 \pm 0.39; \\
 \tau &= 39.1 \pm 5.4 \text{ fs}; \\
 x &= +0.269 \pm 0.044; \\
 g_E/g_A &= +3.8 \pm 1.3 \text{ (C/A)}.
 \end{aligned}
 \tag{26}$$

The precision on x (resp. g_E/g_A) could be somewhat improved if the mixing ratio δ would be measured in a separate experiment. This feature is illustrated in Table 3 below.

δ	τ [fs]	x	g_P/g_A (C/A)	χ^2	
				full	norm.
-0.20	75 ± 6	$+0.262 \pm 0.080$	$+3.6 \pm 2.4$	456.2	0.871
-0.10	70 ± 4	$+0.326 \pm 0.082$	$+5.5 \pm 2.3$	443.2	0.846
0.00	63 ± 3	$+0.340 \pm 0.073$	$+5.9 \pm 2.0$	432.3	0.825
+0.10	55 ± 3	$+0.329 \pm 0.061$	$+5.5 \pm 1.7$	424.6	0.810
+0.20	49 ± 2	$+0.311 \pm 0.051$	$+5.0 \pm 1.5$	420.1	0.802
+0.40	42 ± 2	$+0.280 \pm 0.040$	$+4.2 \pm 1.2$	417.0	0.796
+0.60	38 ± 3	$+0.266 \pm 0.036$	$+3.7 \pm 1.1$	416.8	0.795
+0.80	38 ± 3	$+0.263 \pm 0.036$	$+3.7 \pm 1.1$	416.8	0.795
+1.00	39 ± 3	$+0.268 \pm 0.037$	$+3.8 \pm 1.1$	416.8	0.795
+1.20	39 ± 3	$+0.268 \pm 0.044$	$+3.8 \pm 1.3$	417.0	0.802

4.4 Both the 1229 and the 2171 keV γ -lines; composite background.

As the final and most realistic approach let us take now into account the composite structure of the background in the 1200 – 1240 keV region. As it was mentioned above, this background should include:

1. An asymmetric triangular line *1205 keV* from the reaction $^{74}\text{Ge}(n, n')^{74}\text{Ge}^{1205}$ with the unknown area S_{1205} and with the known width of the high energy tail Δ_{1205} . This value was estimated from the analysis of the similar *596, 608, 691 and 1040 keV* lines. In our fit it was fixed to

$$\Delta_{1205} = 32.5 \text{ keV} . \quad (27)$$

2. An isosceles triangular line of *1222 keV* from the reaction $^{28}\text{Si}(\mu, \nu n)^{27}\text{Al}^{3956}$ with the unknown area S_{1222} and with the known half-width Δ_{1222} . The value of Δ_{1222} was estimated from the analysis of the similar *1719, 2210 and 2941 keV* lines. In our fit it was fixed to

$$\Delta_{1222} = 6.35 \text{ keV} . \quad (28)$$

3. A normal (unbroadened Gaussian) line of *1238 keV* from the reaction $^{56}\text{Fe}(n, n')^{56}\text{Fe}^{2085}$ with the unknown area S_{1238}

So, we repeated the previous fitting procedure, after the determination of the linear part of the background and that of the peak positions as discussed above, with the following free parameters :

- the γ -line areas (8),
- the \tilde{x} -value (1),
- the *2202 keV* level life-time τ (1),
- the *E2/M1* mixing ratio δ for the *2171 keV* γ -line (1),
- the areas S_{1205} of the *1205 keV* γ -lines (4),
- the ratio S_{1222}/S_{1229} (1),

- the areas S_{1238} of the 1238 keV γ -lines (4).

The fit is excellent as illustrated in Fig.4. The resulting parameters do not differ significantly from the previous one and give us additional confidence in the background-independence of our result :

$$\begin{aligned}
 \delta &= +0.74 \pm 0.29 ; \\
 \tau &= 38.2 \pm 2.8 \text{ fs} ; \\
 x &= +0.254 \pm 0.034 ; \\
 S_{1222}/S_{1229} &= 0.106 \pm 0.014 ; \\
 g_P/g_A &= +3.4 \pm 1.0 \text{ (CA)} .
 \end{aligned}
 \tag{29}$$

As in the previous fit, the result would be more precise if we would know the δ -value from any other independent experiment. The slight dependance of the results on the δ -value is illustrated in Table 4.

δ	τ [fs]	x	g_P/g_A (CA)	χ^2	
				full	norm.
-0.20	73 ± 6	$+0.242 \pm 0.072$	$+3.0 \pm 2.2$	659.4	0.882
-0.10	69 ± 4	$+0.299 \pm 0.072$	$+4.7 \pm 2.1$	646.8	0.865
0.00	62 ± 3	$+0.315 \pm 0.064$	$+5.2 \pm 1.8$	636.0	0.850
+0.10	55 ± 3	$+0.308 \pm 0.055$	$+5.0 \pm 1.6$	628.3	0.840
+0.20	49 ± 2	$+0.294 \pm 0.047$	$+4.6 \pm 1.4$	623.5	0.834
+0.40	42 ± 2	$+0.269 \pm 0.038$	$+3.8 \pm 1.1$	619.9	0.829
+0.60	39 ± 3	$+0.256 \pm 0.035$	$+3.4 \pm 1.1$	619.4	0.828
+0.80	38 ± 3	$+0.255 \pm 0.034$	$+3.4 \pm 1.0$	619.4	0.828
+1.00	39 ± 3	$+0.259 \pm 0.035$	$+3.5 \pm 1.1$	619.4	0.828
+1.20	41 ± 2	$+0.266 \pm 0.037$	$+3.7 \pm 1.1$	619.7	0.829

It should be noted that the compiled background visible under the 1229 keV line (Fig.4a, 4b) can be suppressed using a γ - γ coincidence requirement; this approach was followed by D.S.Armstrong et al., in a TRIUMF-experiment similar to the one reported here [57].

4.5 1229 and 2171 keV γ -lines: composite background including the contribution of the $^{29}\text{Si}(\mu, \nu n)$ reaction.

Before concluding, we discuss briefly the eventual impact of contributions from the contaminant $^{29}\text{Si}(\mu, \nu n)$ reaction. As it was mentioned above, the contribution of this reaction is unknown, but if the corresponding γ -yields for ^{28}Si and ^{29}Si are similar — then the contribution ξ of the "isosceles triangle" to both the 1229 and the 2171 keV γ -lines should be within several per cent. In order to investigate the impact of this value on the results, the previous fitting was repeated with the same free parameters but with a *non-zero* fixed value for ξ . The half-width of the "triangle" was estimated from 1719 , 2210 and 2941 keV lines :

$$\begin{aligned}
 \Delta_{1229} &= 8.8 \text{ keV} , \\
 \Delta_{2171} &= 15.6 \text{ keV} .
 \end{aligned}
 \tag{30}$$

The results are shown below (Table 5).

ξ	δ	τ [fs]	x	g_P/g_A (CA)	χ^2	
					full	norm.
0.00	$+0.74 \pm 2.90$	38 ± 3	$+0.251 \pm 0.034$	$+3.1 \pm 1.1$	619.1	0.832
0.05	$+0.62 \pm 0.71$	38 ± 5	$+0.263 \pm 0.043$	$+3.6 \pm 1.3$	613.6	0.825
0.10	$+0.59 \pm 0.27$	38 ± 5	$+0.272 \pm 0.043$	$+3.9 \pm 1.3$	609.1	0.819
0.15	$+0.51 \pm 0.41$	38 ± 6	$+0.281 \pm 0.047$	$+4.2 \pm 1.4$	605.7	0.814
0.20	$+0.52 \pm 0.35$	38 ± 6	$+0.290 \pm 0.050$	$+4.4 \pm 1.5$	603.1	0.811

As it can be seen from the Table 5, a slight 5-10% contribution from the $^{29}\text{Si}(\mu, \nu n)$ reaction would not be crucial but a large value would significantly modify our results. To take this eventual modification into account, one has to measure the relative yield of the 1398 keV and $1229, 2171 \text{ keV}$ γ quanta with an enriched ^{29}Si target and determine the precise shape of these “triangular” lines.

5 Discussion and conclusions

- Our most reliable results are the ones obtained in the analysis discussed in 4.4 and reported in Table 4. We measured parameter $x := M_1(2)/M_1(-1)$ (Equ.29). Its translation to g_P/g_A requires however the use of a nuclear model. This feature is illustrated in Fig.5 where we compare the relation between g_P/g_A and x obtained in a realistic nuclear model (CA , ref [36]) to the one obtained in the Fujii-Primakoff approximation (PPA ; Equ.23) which becomes model-independent neglecting all matrix elements other than the leading $[101]$ one.

In Fig.5 we show also the measured value of x (Equ.29) and the value of g_P/g_A deduced from it evaluating the correction-terms using a realistic nuclear model (CA). Taken at face value, this result would indicate a sizeable $(3.1 \pm 1.1/7) \approx (50 \pm 11)\%$ quenching of g_P/g_A compared to its value predicted by $PCAC$ (Equ.2). As, however, the use of the $1P$ -approximation results in no quenching (cfr. Fig.5), one has to investigate the sensitivity of this intriguing result to the model used by the author of ref.[36] (CA). A group of theoreticians at JINR, Dubna is actually undertaking this task.

- To reduce the number of free parameters and thus to improve precision on the parameter x and make it more reliable two additional independent measurements should be done :

1. *The measurement of the γ -spectrum in μ -capture by an enriched ^{29}Si target.* Such a relatively short measurement would provide the yield as well as the precise line shape of the 1229 and 2171 keV γ -lines emitted in the $^{29}\text{Si}(\mu, \nu n)$ reaction with respect to the 1398 keV γ -line from the $^{29}\text{Si}(\mu, \nu)$ reaction. Knowing the detector efficiency and comparing these data with the 1398 keV γ -line observed in this work, one could extract the precise ξ and Δ values of the “isosceles triangular” contributions discussed in section 4.5. We should stress that our result (Equ.29, Fig.5) neglects this contribution ($\xi = 0$) and one has to verify the reliability of this assumption.
2. *The measurement of the angular distribution of the prompt 1229 and 2171 keV γ -quanta in the $^{29}\text{Mg}({}^3\text{He}, p)$ reaction.* The excited $^{28}\text{Al}^{2202}$ nucleus obtained

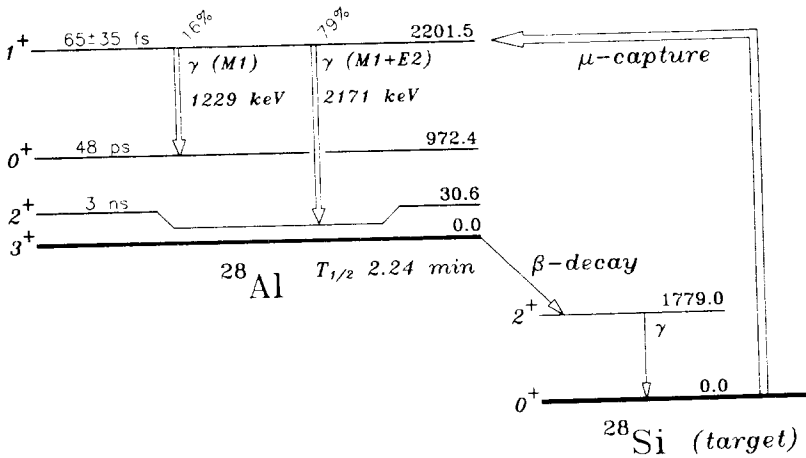

1. Some of the relevant excited levels of ^{28}Al populated in muon capture by ^{28}Si .

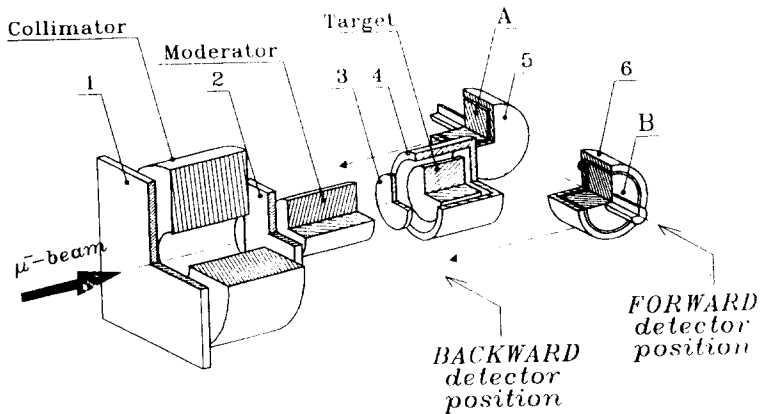

1..6 - Plastic scintillators

A,B - Moveable HP Ge γ -detectors

Hard trigger :

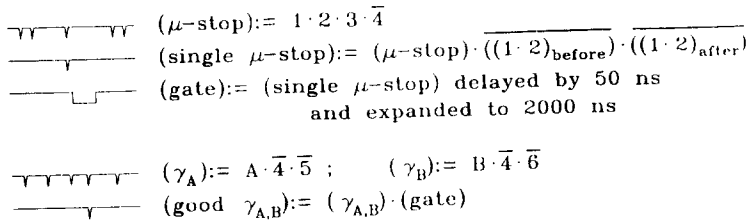

2. The experimental set-up and trigger-logic.

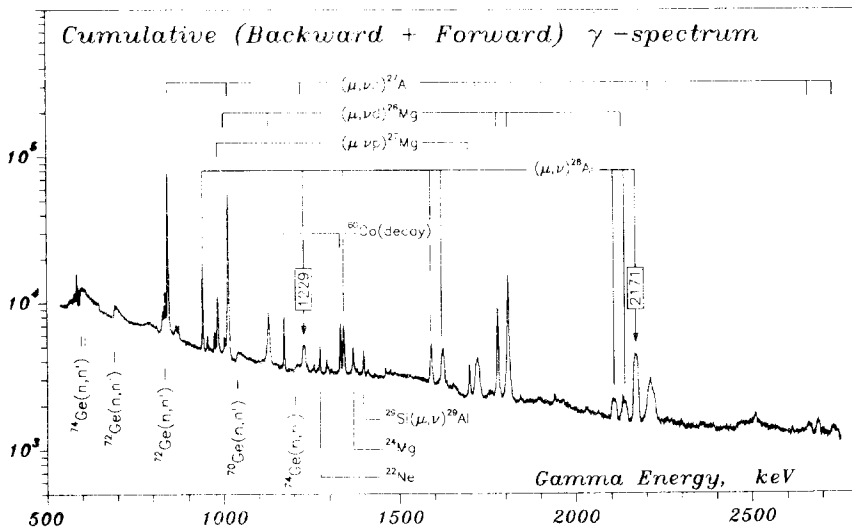

3. The cumulative γ -spectrum i.e. the sum of all "good γ " measured by both Ge detectors in both positions during 130 hours of total measuring time.

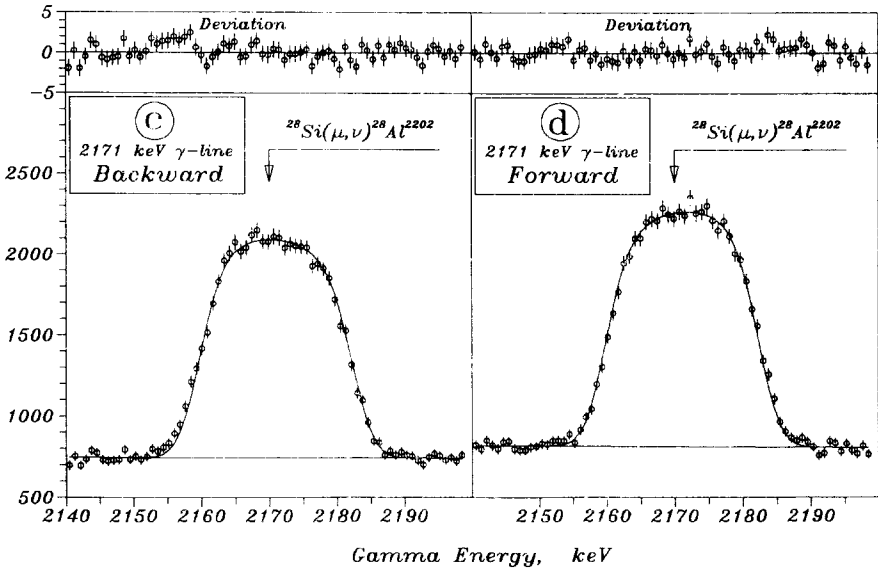
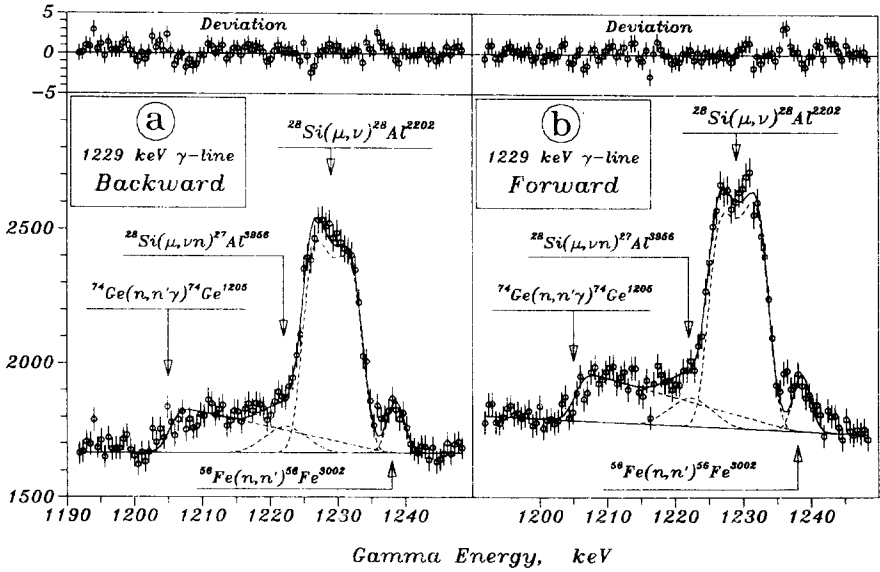

4. The best fit to the 1229 keV and 2171 keV γ -lines under conditions discussed in section 4.4. Some slight systematic excess of the deviations can be attributed to the non-Gaussian nature of the response function.

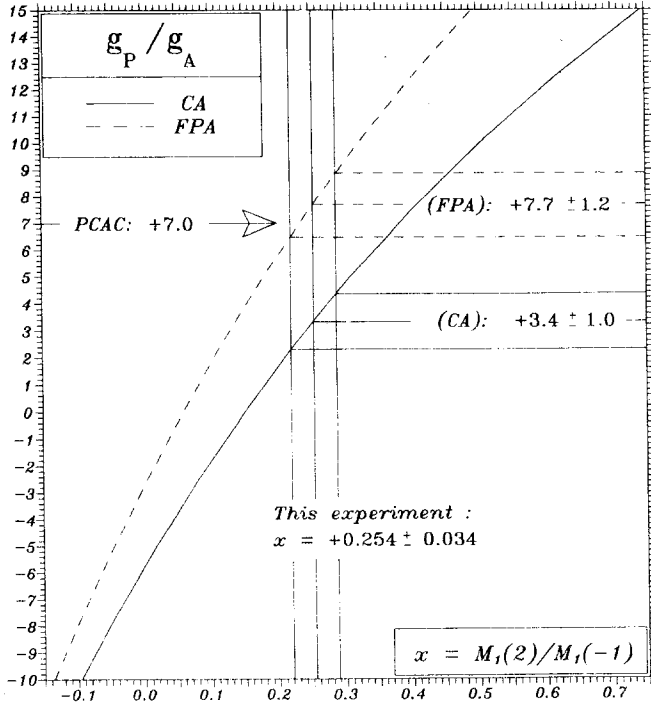

5. Dependence of g_P/g_A on the parameter x measured in this experiment (CA : evaluation of ref.[36], FPA : nuclear model independent approximation; cfr. text). Our result (cfr.4.4) is shown as well as the resulting value, to be compared to the PCAC-prediction.

in this reaction [58, 59] or a similar one would be produced with a non-zero alignment and, therefore, comparing the angular distribution of these (MI) and ($MI + \delta \cdot E2$) quanta, one could extract the δ -value of the 2171 keV transition. This would improve the precision on the parameter x (cfr. section 4.4).

- More generally, in order to reduce the eventual systematic errors and to minimize both the correlated and the uncorrelated background, the experimental set-up should be improved in various respects:
 1. it should be complemented with magnetic coils to use of muon spin rotation instead of moving the γ -detector (this would allow to measure various \bar{P} -values simultaneously in the same experiment and to keep the beam-target-detector geometry constant);
 2. neither shielding nor beam collimation with heavy materials should be used to reduce the uncorrelated neutron flux producing the (n, n') reaction in the Ge detectors;
 3. the active shielding of the Ge detectors should be improved to make this shielding more effective against both the Michel-electrons and the neutrons and thus to reduce the correlated background.

6 Acknowledgments

We would like to thank the staff of JINR Phasotron and Beam group for their support during the experiment, Dr. T.Mamedov for his mSR-measurements and Dr. V.Zinov for fruitful discussions. We are indebted to Dr. V.Sandukovsky and A.Revenko who prepared HP Ge detectors.

References

- [1] H.Primakoff, Rev. Mod. Phys. **31** (1959) 802.
- [2] Particle Data Group, Phys. Rev. **D45** (1992) VIII.9.
- [3] M.L.Goldberger and S.B.Treiman, Phys. Rev. **111** (1958) 354.
- [4] L.Grenacs, Ann. Rev. Nucl. Part. Sci. **35** (1985) 455.
- [5] G.Bardin *et al.*, Nucl. Phys. **A352** (1981) 365;
Phys. Lett. **104B** (1981) 320.
- [6] M.Hasinoff, *private communication*.
- [7] L.I.Ponomarev, Proc. of the Int. Conf. on Muonic Atoms and Molecules, Monte Verita, Birkhauser Verlag, Basel (1993) 129;
Nucl. Phys. **A384** (1982) 302.
- [8] S.Wycech, Nucl. Phys. **B14** (1969) 133.
- [9] M.Ericsson, Prog. Nucl. Part. Phys. **1** (1978) 67.

- [10] V.V.Balashov, G.J.Korenman, R.A.Eramzhyan, "Pogloschenie mezonov atomnymi yadrami", Atonizdat, Moscow, 1978.
- [11] P.Desgroland and P.Guichon, Phys. Rev. **C19** (1979) 120.
- [12] M.Lutz, S.Klimt and W.Weise, Nucl. Phys. **A542** (1992) 521.
- [13] E.G.Adelberger *et al.*, Phys. Rev. Lett. **67** (1991) 3658.
- [14] E.K.Warburton, Phys. Rev. **C43** (1991) 233.
- [15] K.Kubodera and M.Rho, Phys. Rev. Lett. **67** (1991) 3479.
- [16] L.Ph.Roesch *et al.*, Phys. Rev. Lett. **46** (1981) 1507.
- [17] M.Fukui *et al.*, Phys. Lett. **B132** (1983) 255.
- [18] Y.Kuno *et al.*, Phys. Lett. **B148** (1984) 270.
- [19] A.Frischknecht *et al.*, Phys. Rev. **C32** (1985) 1506.
- [20] M.Dobeli *et al.*, Phys. Rev. **C37** (1988) 1633.
- [21] D.Armstrong *et al.*, Phys. Rev. **C40** (1989) 1506.
- [22] D.Armstrong *et al.*, Phys. Rev. **C43** (1991) 1425.
- [23] D.Armstrong *et al.*, Phys. Rev. **C46** (1992) 1094.
- [24] H.W.Fearing and M.S.Welsh, Phys. Rev. **C46** (1992) 2077.
- [25] N.P.Popov, Zh. Eksp. Teor. Fiz. **44** (1963) 1679.
- [26] G.M.Bukat and N.P.Popov, Zh. Eksp. Teor. Fiz. **46** (1964) 1782.
- [27] A.P.Bukhvostov and N.P.Popov, Phys. Lett. **B24** (1967) 487.
- [28] Z.Oziewicz and A.Pikulski, Acta Phys. Pol. **32** (1967) 873.
- [29] M.Morita and A.Fujii, Phys. Rev. **118** (1960) 606.
- [30] V.V.Balashov and R.A.Eramzhyan, Atomic Energy Review, (Vienna), **5** (1967) 3.
- [31] R.A.Eramzhyan, Proc. of III Int. Symp. on Weak and Electromagnetic Interaction (WEIN-92), Dubna,Russia, June 16-22, 1992 (World-Scientific, Singapore, 1992) 282.
- [32] A.Fujii and H.Primakoff, Nuo. Cim. **12** (1959) 327.
- [33] H.Primakoff, Elementary-particle aspects of muon decay and muon capture. *In* : "Muon Physics", ed. V.W.Hughes, C.S.Wu, N.-Y., Academic Press, v.2 (1975) 3-48.
- [34] G.H.Miller *et al.*, Phys. Rev. Lett. **29** (1972) 1194.
- [35] B.R.Holstain, Phys. Rev. **C29** (1984) 623.
- [36] S.Ciechanowicz, Nucl. Phys. **A267** (1976) 472.

- [37] R.Parthasarathy and V.N.Sridhar, Phys. Rev. **C18** (1978) 1796.
- [38] R.Parthasarathy and V.N.Sridhar, Phys. Rev. **C23** (1981) 861.
- [39] L.Grenacs *et al.*, Nucl. Instr. and Meth. **58** (1968) 164.
- [40] J.Lindhard, M.Scharff, H.E.Schiott, Dansk. Vid. Selsk. Mat.-Fys. Medd. **33** (1963) 3.
- [41] A.E.Blaugrund, Nucl. Phys. **88** (1966) 5017.
- [42] K.B.Winterborn, Nucl. Phys. **A246** (1975) 293.
- [43] S.Kalbitzer *et al.*, Z. Phys. **A278** (1976) 223.
- [44] I.Kh.Lemberg, A.A.Pasternak, Sovremennyye metody yadernoi spektroskopii, Leningrad, "Nauka", 1985, 3.
- [45] M.K.Georgiova *et al.*, Elem. Chast. i At. Yadra. **20** (1989) 9307.
- [46] G.H.Miller *et al.*, Phys. Rev. **C6** (1972) 487.
- [47] H.J.Evans, Nucl. Phys. **A207** (1973) 379.
- [48] L.Ph.Roesch *et al.*, Phys. Lett. **B107** (1981) 31.
- [49] V.S.Evseev, Depolarization of Negative Muons and Interaction of Mesonic Atoms with the Medium. In : "Muon Physics", ed. V.W.Hughes, C.S.Wu, N.-Y., Academic Press, v.3 (1975) 235-298.
- [50] P.M.Endt, "Energy levels of A=21-44 nuclei", Nucl. Phys. **A521** (1990) 1.
- [51] M.P.Balandin *et al.*, JINR, Dubna, **9-90-435** (1990).
- [52] V.G.Egorov *et al.*, JINR, Dubna, **P6-91-430** (1991).
- [53] K.C.Chung *et al.*, Phys. Rev. **C2** (1970) 139.
- [54] R.L.Bunting and J.J.Kraushaar, Nucl. Instr. and Meth. **118** (1974) 565.
- [55] G.Braun, A.Bockisch, W.Neuwirth, Nucl. Instr. and Meth. **224** (1984) 112.
- [56] A.Shinohara *et al.*, KEK Preprint **93-132** (1993);
(to be published in Nucl. Instr. and Meth. **B**).
- [57] D.S.Armstrong *et al.*, Report at Int. Workshop on Low Energy Muon Science, April 4-8, 1993, Santa Fe, NM.
- [58] D.O.Boerma and Ph.B.Smith, Phys. Rev **C4** (1971) 1200.
- [59] D.F.Start *et al.*, Nucl. Phys. **A206** (1973) 207.

Received by Publishing Department
on September 28, 1994.

Принимается подписка на препринты, сообщения Объединенного института ядерных исследований и «Краткие сообщения ОИЯИ».

Установлена следующая стоимость подписки на 12 месяцев на издания ОИЯИ, включая пересылку, по отдельным тематическим категориям:

Индекс	Тематика	Цена подписки на год
1.	Экспериментальная физика высоких энергий	22600 р.
2.	Теоретическая физика высоких энергий	59200 р.
3.	Экспериментальная нейтронная физика	7800 р.
4.	Теоретическая физика низких энергий	23400 р.
5.	Математика	14800 р.
6.	Ядерная спектроскопия и радиохимия	12000 р.
7.	Физика тяжелых ионов	2200 р.
8.	Криогеника	1400 р.
9.	Ускорители	12200 р.
10.	Автоматизация обработки экспериментальных данных	12200 р.
11.	Вычислительная математика и техника	14300 р.
12.	Химия	1200 р.
13.	Техника физического эксперимента	21300 р.
14.	Исследования твердых тел и жидкостей ядерными методами	7200 р.
15.	Экспериментальная физика ядерных реакций при низких энергиях	2600 р.
16.	Дозиметрия и физика защиты	2200 р.
17.	Теория конденсированного состояния	12200 р.
18.	Использование результатов и методов фундаментальных физических исследований в смежных областях науки и техники	1800 р.
19.	Биофизика	1800 р.
	«Краткие сообщения ОИЯИ» (5—6 выпусков)	15000 р.

Подписка может быть оформлена с любого месяца года.

Организациям и лицам, заинтересованным в получении изданий ОИЯИ, следует перевести (или отправить по почте) необходимую сумму на расчетный счет 000608905 Дубненского филиала ММКБ, г.Дубна Московской области, п/инд. 141980 МФО 211844, указав: «За подписку на издания ОИЯИ».

Во избежание недоразумений необходимо уведомить издательский отдел о произведенной оплате и вернуть «Карточку подписчика», отметив в ней номера и названия тематических категорий, на которые оформляется подписка, по адресу:

141980 г. Дубна Московской обл.
ул.Жолио Кюри, 6
ОИЯИ, издательский отдел

Бруданин В. и др.

E6-94-382

Измерение формфактора индуцированного псевдоскалярного взаимодействия в захвате поляризованных мюонов ядрами Si

С помощью Ge-детекторов высокого разрешения регистрировались гамма-кванты 1229 кэВ и 2171 кэВ, сопровождающие реакцию $^{28}\text{Si}(\mu, \nu)^{28}\text{Al}(1^+, 2202 \text{ кэВ})$, что позволило определить отношение ядерных амплитуд $x \equiv M(2)/M(-1)$, характеризующее процесс мюонного захвата. В рамках теоретической модели С.Цехановича, использующей зависящие от ядерной структуры поправочные члены, наш результат $x = +0,254 \pm 0,034$ соответствует следующему значению формфактора индуцированного псевдоскалярного взаимодействия: $g_P/g_A(0,848 m_\mu^2) = 3,4 \pm 1,0$ (гипотеза PCAC предсказывает значение $g_P/g_A = 7$). Вопрос о модельной зависимости обнаруженного подавления g_P остается открытым.

Работа выполнена в Лаборатории ядерных проблем ОИЯИ.

Препринт Объединенного института ядерных исследований. Дубна, 1994

Brudanin V. et al.

E6-94-382

Measurement of the Induced Pseudoscalar Form Factor in the Capture of Polarized Muons by Si Nuclei

The observation with high resolution Ge-detectors of the 1229 keV and 2171 keV gamma-rays emitted in the $^{28}\text{Si}(\mu, \nu)^{28}\text{Al}(1^+, 2202 \text{ keV})$ reaction allowed us to determine the nuclear-amplitude ratio $x \equiv M(2)/M(-1)$ characteristic of this muon-capture reaction. Using the nuclear-structure dependent evaluation of various correction terms (model of S.Ciechanowicz), our result $x = +0.254 \pm 0.034$ provides for the Induced Pseudoscalar coupling g_P the ratio $g_P/g_A(0,848 m_\mu^2) = 3.4 \pm 1.0$, to be compared to the PCAC-prediction of $g_P/g_A = 7$. The model-dependence of this apparent quenching remains to be assessed.

The investigation has been performed at the Laboratory of Nuclear Problems, JINR.

Preprint of the Joint Institute for Nuclear Research Dubna, 1994

Макет Т.Е.Попеко

Подписано в печать 06.12.94
Формат 60×90/16. Офсетная печать. Уч.-изд.листов 1,67
Тираж 365. Заказ 47784. Цена 300 р.

Издательский отдел Объединенного института ядерных исследований
Дубна Московской области