

LL

CERN LIBRARIES, GENEVA



P00021685

-SSCL-P 521
SW 9418

SSCL-Preprint-521

October 1993

Distribution Category: 414

Superconducting Magnets, Cryostats, and Cryogenics for the Interaction Region of the SSC

R. Jayakumar
S. Abramovich
A. Ahmad
B. Archer
W. Clay
C. Goodzeit
A. Harvey
A. Jalloh
Q. Shu
G. Snitchler
R. Stiening

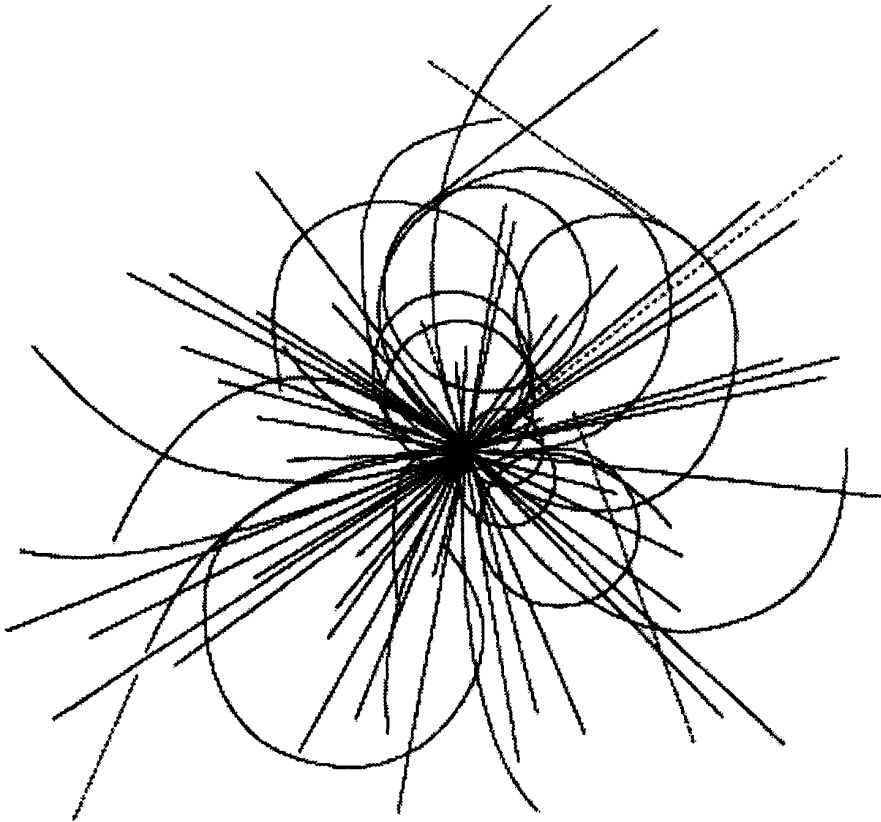

Superconducting Super Collider Laboratory

Disclaimer Notice

This report was prepared as an account of work sponsored by an agency of the United States Government. Neither the United States Government or any agency thereof, nor any of their employees, makes any warranty, express or implied, or assumes any legal liability or responsibility for the accuracy, completeness, or usefulness of any information, apparatus, product, or process disclosed, or represents that its use would not infringe privately owned rights. Reference herein to any specific commercial product, process, or service by trade name, trademark, manufacturer, or otherwise, does not necessarily constitute or imply its endorsement, recommendation, or favoring by the United States Government or any agency thereof. The views and opinions of authors expressed herein do not necessarily state or reflect those of the United States Government or any agency thereof.

Superconducting Super Collider Laboratory is an equal opportunity employer.

**Superconducting Magnets, Cryostats, and Cryogenics
for the Interaction Region of the SSC***

R. Jayakumar, S. Abramovich, A. Ahmad, *et al.*

Superconducting Super Collider Laboratory†
2550 Beckleymeade Ave.
Dallas, TX 75237, USA

October 1993

*To be submitted to the Plenum Publishing Corporation.

†Operated by the Universities Research Association, Inc., for the U.S. Department of Energy under Contract No. DE-AC35-89ER40486.

SUPERCONDUCTING MAGNETS, CRYOSTATS, AND CRYOGENICS FOR THE INTERACTION REGION OF THE SSC

R. Jay Jayakumar, Shaul Abramovich, Aziz Ahmad, Bill Archer,
Wayne Clay, Carl Goodzeit, Alex Harvey, Abdul Jalloh, Quan-Sheng Shu,
Greg Snitchler, and Rae Stiening

Superconducting Super Collider Laboratory
2550 Beckleymeade Avenue
Dallas, TX 75237

INTRODUCTION

The Superconducting Super Collider (SSC) has two counterrotating 20-TeV proton beams that will be made to collide at specific interaction points to carry out high energy physics experiments (see Figure 1). The Collider ring has two sites, West and East, for such Interaction Regions (IRs), and the conceptual design of the East Interaction Region is underway. The East IR, in the present stage of design, has two interaction points, the requirements for which have been specified in terms of distance L^* to the nearest (focusing quadrupole) magnet and the beam luminosity. Based on these requirements, the optics for transition from arc regions or utility regions to the IR and for focusing (beta squeeze) the beams have been obtained.¹ The arrangement of superconducting magnets in the IR is shown in Figure 2. The optical arrangement consists of a tuning section of quadrupoles, the strength of which is adjusted to obtain the required beta squeeze; a pair of bending dipoles to reduce the beam separation from the nominal 900 mm to 450 mm; an achromat section of quadrupoles, which consist of two cold masses in one cryostat; another pair of dipoles to bring the beams together at the required crossing angle; and a set of final focus quads facing the interaction point. The optics is symmetric about the interaction point, and the two interaction points are separated by a hinge region consisting of superconducting dipoles and quadrupoles similar to the arc region. In the regions where the beams are vertically bent and straightened out by dipoles, the beam traverses warm regions provided for placing beam collimators. Table 1 summarizes the superconducting magnet strengths, apertures, and lengths. The superconducting magnets, including the final focus quadrupoles, operate with supercritical He at 4 atm and a nominal temperature of 4.15 K. In this paper, descriptions of the magnets, the cryostats, and cryo bypasses around the warm region and interaction points are provided. Also discussed are the cooling requirements and design for the final focus quadrupole, which receives significant heat load from beam radiation.

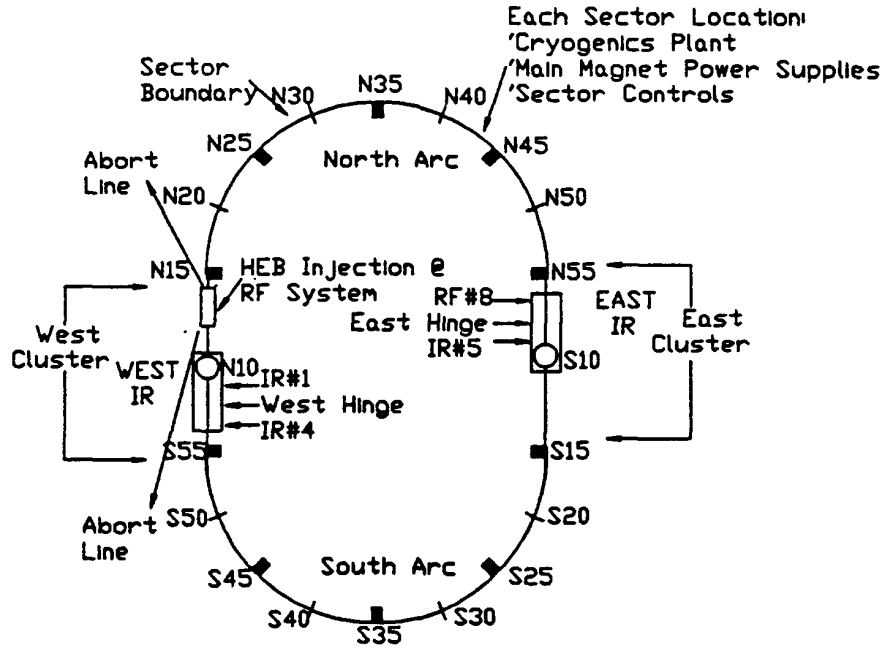

Figure 1. The Super Collider and the Interaction Regions.

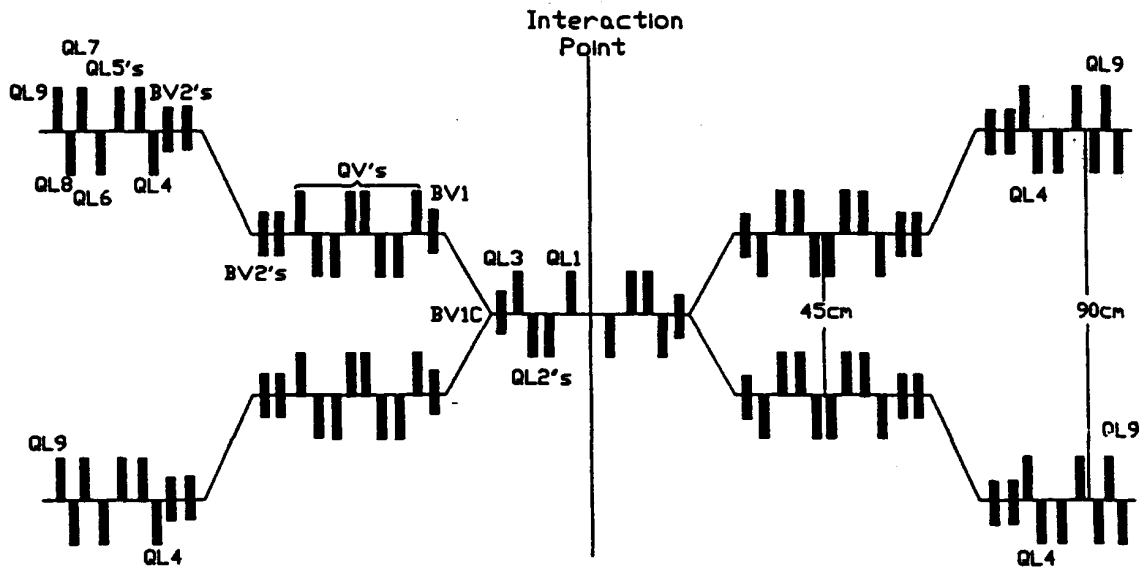

Figure 2. Optics and arrangement of magnets in the IR.

Table 1. Magnet properties.

| Magnet Name | Aperture (mm) | Length (m) | Gradient(T/m) or Field (T) – max |
|-------------------|---------------|------------|-------------------------------------|
| QL1 Quad | 50 | 15.565 | 190.894 |
| QL2 Quad | 50 | 11.855 | 190.894 |
| QL3 Quad | 50 | 13.171 | 190.894 |
| QL4 Quad | 50 | 10.200 | 174.9 |
| QL5 Quad | 50 | 8.000 | 175.5 |
| QL6 Quad | 50 | 8.000 | 160.5 |
| QL7 Quad | 50 | 8.600 | 183.5 |
| QL8 Quad | 50 | 8.000 | 171.0 |
| QL9 Quad | 50 | 10.200 | 175.5 |
| QVF/D Quad-2 in 1 | 50 | 8.000 | 190.894 |
| BV1 Vert Bend | 50 | 14.926 | 6.791 |
| BV2 Vert Bend | 50 | 12.439 | 6.791 |
| BV1C Vert Bend | 87 | 15.839 | 6.400 |
| B (Hinge) | 50 | 14.926 | 6.791 |
| BS (Hinge) | 50 | 12.439 | 6.791 |

SUPERCONDUCTING MAGNETS AND CRYOSTATS

Quadrupole Magnets

Cold Mass. All the quadrupoles in the IR utilize a 50-mm aperture and a nominal gradient of about 190 T/m at 6560 A, with adjustment of gradient for each quadrupole with a trim supply during injection, beam storage, and beta squeeze. The quadrupoles² of different lengths will use the same cross section (see Figure 3) and will utilize a two-layer coil design with the outer layer wound over the inner layer and cured. The cable, made with 36 superconducting strands with Cu/SC ratio of 1.8:1 and a diameter of 0.648, is insulated with an all-polyimide insulation cured at about 180°C. The inner layer has 11 turns and the outer has 16 turns. The ends of the turns are supported by end parts made from radiation-resistant FRP (e.g., G11). The four inner-outer pairs with additional ground insulation placed over them are clamped together by a top-bottom pair of stainless steel collars keyed in the mid-plane to obtain the required prestress in the coil (average of about 30 MPa when cold). The collared coil is in turn held tightly in a cavity obtained from a top-bottom pair of steel yokes, which provide magnetic shielding and additional field contribution. The yokes also have holes/slots to carry the He flow and the superconducting bus cooled by the He flow. The assembly is held together by a surrounding shell that acts as a He vessel and is obtained by welding two halves together in a press. A beam tube of 42.65-mm OD is coaxially placed inside the coils, and liquid He flows in the annular space between the inner diameter of the coil and the beam tube. This flow (3 g/s) is adequate for keeping the coils at the required operating temperature, with satisfactory margin for magnets that are not in the final focus region. For magnets in the final focus region, a cross flow arrangement will be utilized to keep the coil temperature low under the conditions of beam radiation heat load. The details are described in a later section.

Cryostat. The magnet cryostat, which is derived from a Fermi National Accelerator Laboratory design for the Accelerator System String Test dipole,³ is under development at SSCL. The design is made to be flexible so that developments in the collider dipole and quadrupole magnets can be taken advantage of. The description⁴ presented below is that for the developmental design; final design for the IR quads is likely to be finalized later. The summary of requirements for the cryostats are:

| | |
|--------------------------|---|
| Structural loads: | 0.5 G lateral 0.5 G axial 3.0 G vertical |
| Static heat load budget: | 0.363 W at 4 K 5.05 W at 20 K 37 W at 80 K |
| Cold mass sag: | < 0.06 mm @ cold mass weight of about 500 kg/m cold mass stiffness of $4.7 \times 10^7 \text{ mm}^4$ |

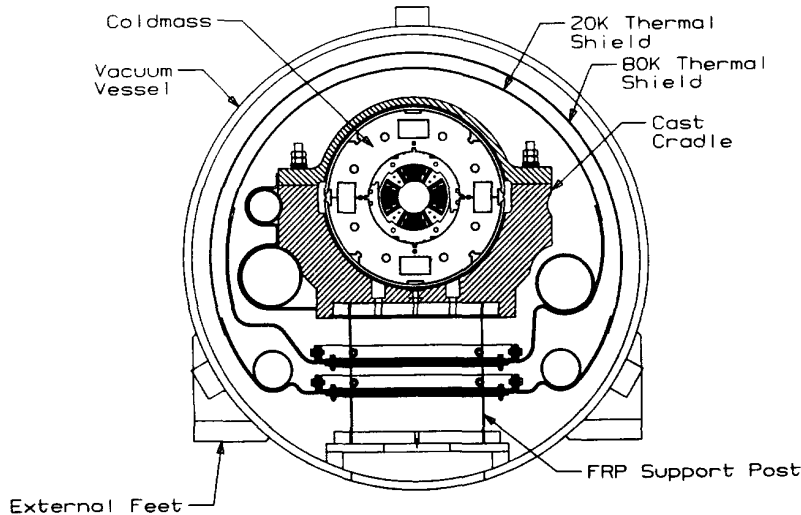

Figure 3. Cross section of IR quadrupole.

The cryostat and the cold mass design and assembly procedures are required to meet ASME pressure vessel and piping code requirements.

The cross section of the quadrupole cryostat is shown in Figure 3. The cryostat consists of a cast cradle to support the cold mass, which in turn is supported by an FRP suspension post. The cold mass is shielded from infrared radiation from the higher-temperature components by a radiation shield maintained at 20 K with helium gas. The 20-K shield is in turn shielded for infrared radiation from the room temperature by an 80-K shield that is also wrapped with multilayer insulation. The cryostat is maintained in insulating vacuum by a steel vacuum vessel.

The cast cradle is made of two top-and-bottom parts that are strapped together. The lower section is made of cast steel and is machined. Since the design requires that the cold mass slide with minimum friction, the cradle will be coated with appropriate lubricant. Various lubricants (polyimide-based) and a liner consisting of graphite-loaded bronze are being evaluated. The design of the support post is based on a single tube on to which the flanges that support the radiation shield and the disc that forms the cradle interface and the base of the support are shrunk-fit. The dimensions of the post are such as to be interchangeable with the reentrant support designed by General Dynamics for the Collider Dipole Magnet. The shield is fabricated from aluminum and is bolted to the support posts. The various tubes (stainless steel) are held to the shield with special clamps and are connected to the shield by copper straps to ensure thermal contact. The vacuum vessel, made of A516 steel, has a wall thickness of 12.7 mm, which is adequate to support the weight of the cold mass without bending the vessel. The vacuum vessel OD of 711.2 mm meets the requirements for the envelope of the magnet, and the vacuum vessel flanges and

interfaces are defined to be the same as standard collider magnets so as to be able to connect to a standard interconnect.

Vertical Bending Dipoles

The interaction region will use three types of bending dipoles: 50-mm-aperture magnets of approximately 15 m length (BV1); 50-mm-aperture magnets of approximately 13 m length (BV2); and 87-mm-aperture magnet of 15 m length (BV1C). All the 50-mm-aperture magnets in the IR have the same cross section as the Collider Dipole, and the magnets in the 90-cm separation region will have cold masses identical to the Collider Dipole except that the cold mass will be rotated by 90°. In the 2-in-1 region the bending dipole will have the rotated cold masses mounted in a 2-in-1 cryostat.

The BV1C magnet cold mass⁵ is designed to have two layers of 32 turns each, with 30-strand cable of 0.808-mm strands. The magnet will have a quench margin of 11% and a temperature margin of 0.6 K. The magnet design follows traditional designs with 30-mm-wide stainless steel collars and steel yoke, with a total cold mass OD of 480 mm. The magnet will be the largest and strongest magnet to be designed in the program. The cryostat for this magnet has not yet been designed.

2-in-1 Cryostats

In the achromat region the beams are separated by 45 cm, but there is no room for two separate cryostats. Therefore, in this region two cold masses are enclosed in a single cryostat. The magnets in this region are 15-m- and 13-m-long 50-mm-aperture dipoles and quadrupoles of 8-m length. Such a cryostat will weigh up to 30 000 kg with a high center of gravity, and will require careful design for transportation and handling. Several concepts based on existing cryostat designs are being explored; two of them are shown in Figure 4. Other concepts in which the upper magnet was hung from above were rejected because of clearance problems and the requirement of two independent supports, which will complicate alignment. In the elliptic vacuum vessel concept (Figure 4(a)), a single cradle supports both cold masses and is mounted on a single suspension, with structural stabilizers added. The elliptic vacuum vessel and shields may pose buckling problems requiring more expensive design and fabrication techniques. The preferred design shown in Figure 4(b) has round vacuum vessel and shields, and the cradle design is the same. The struts support the cradle against bending loads and are attached to the vacuum vessel.

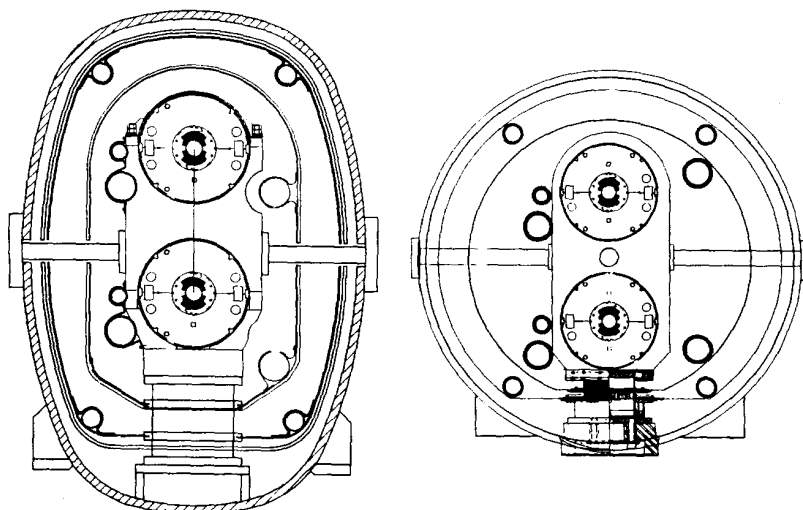

Figure 4. Concepts for 2-in-1 cryostats in the IR region.

Empty Cryostats

The Interaction Region has several drift regions of beam line with no magnets or other beam line equipment. However, the beam, the cryogens, and the magnet current need to be transported across this region; this is accomplished by using an empty (no magnet) cryostat. The total length of empty cryostats for the IR region is 5139 m, of which 4175 m will consist of 15.815-m-long cryostats. (Total number of empty cryostats of different lengths is 392.) The requirements for the device are:

| | |
|-------------------|--------|
| Vertical load | 2.0 g |
| Axial load | 0.5 g |
| Lateral load | 0.5 g |
| Heat load at 4 K | 0.12 W |
| Heat load at 20 K | 3.30 W |
| Heat load at 80 K | 25.4 K |

A number of options for the design are being investigated. One possible choice for cross section of the device is shown in Figure 5. The cryostat part of the device is similar in concept to the Collider dipole, while the cold mass consists of the stainless steel beam tube and two single-phase, liquid-He pipes, with the upper pipe carrying the superconducting bus and the other pipe coaxial with the beam pipe and keeping it cold. The He pipes and the beam tubes are structurally attached to a continuous stainless steel girder that provides stiffness to the pipes against bending (deflection < 1.5 mm). The cold mass is supported by three posts made from 60-mm-diameter FRP tube, with appropriate flanges and discs for supporting the shields and providing the base. An end can for housing the bus expansion loop will be provided to allow for the expansion/contraction of the bus during warm-up and cooldown. The vacuum vessel and interfaces will be the same as the magnet.

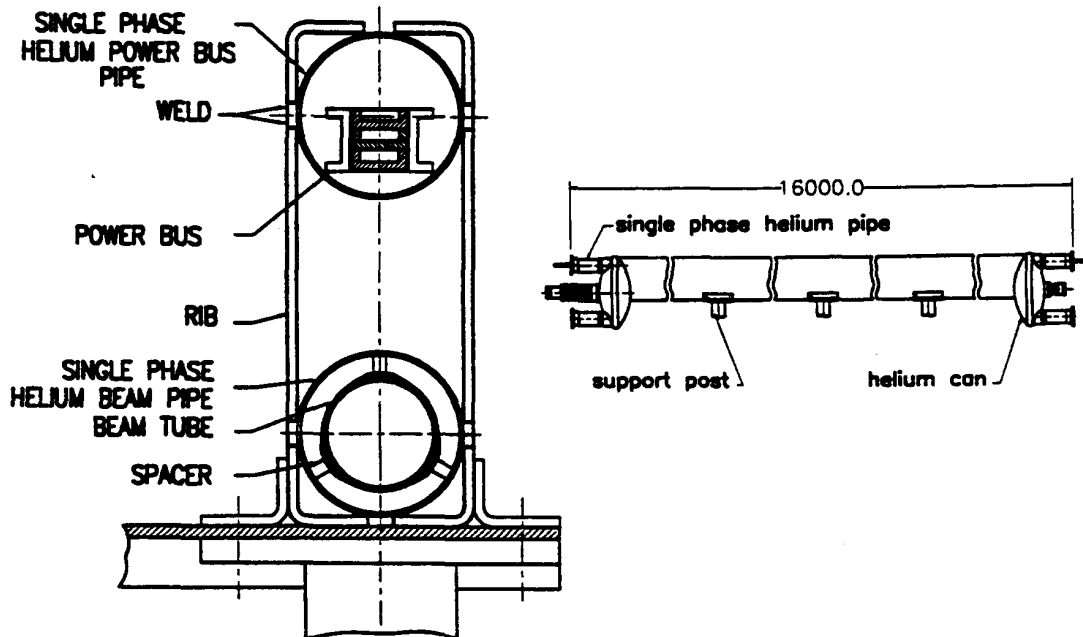

Figure 5. Cross section of empty cryostat and side view.

Cryo Bypass

In the Interaction Region the cryogenic lines and the superconducting bus have to circumvent the warm beam-tube regions in the vertical bend region and the hinge and the experimental hall (the detector and facilities at the IP). The Utility Bypass around the experimental hall is about 1310 m, and the total length of bypass around the warm gaps is about 1770 m. Since there are various transitions and the bypass must meet tunnel requirements, various options have been studied for the end boxes and redistribution. An example of the design for the low-beta final focus quad region is shown in Figure 6. In this design the bypass around the warm beam-tube region between the 2-in-1 magnets and the final splitter magnet BV1C is continued around the experimental hall. The BV1C dipole and the final focus quadrupoles are then fed from lines tapped off the bypass.

The bypasses have somewhat tighter requirements in the heat load, but otherwise have to satisfy requirements similar to those of the empty cryostat.

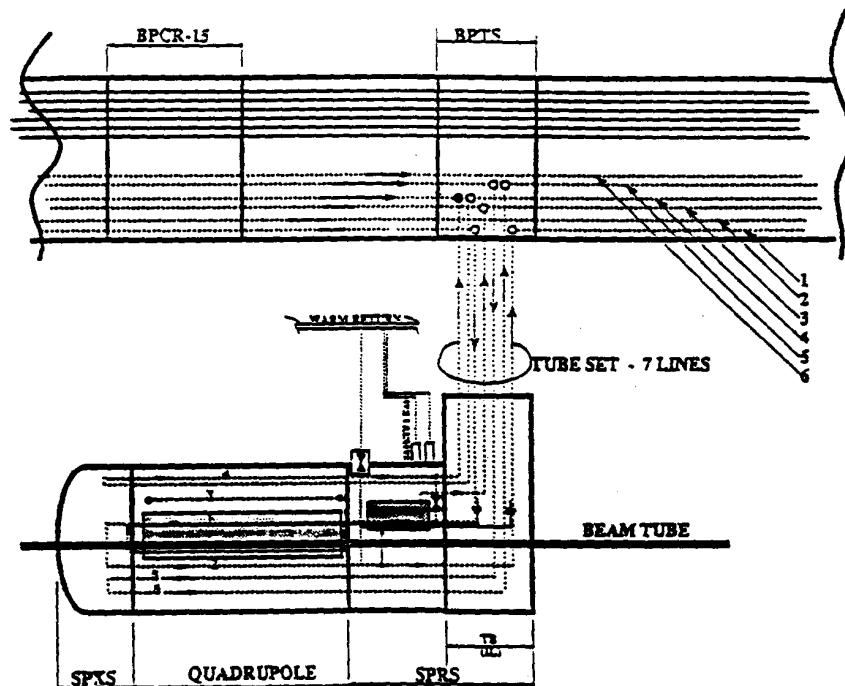

Figure 6. Cryo bypass arrangement in the final focus region.

Cooling of Final Focus Quadrupoles

At the design luminosity of $10^{33} \text{ cm}^{-2}/\text{s}^{-1}$ debris from the interactions represents a constant energy deposition of 600 W. The distribution of this energy for an L^* of 20.5 m has been calculated. A portion of this deposition occurs in the final focus region, and the large-scale energy deposition has to be taken into account in the cooling of the magnets to prevent quenching and in the design of the cryogenic system.

The quadrupoles have a margin of about 1.1 K to quench at the operating gradient and inlet temperature of 4.15 K, and it is desired that 0.6 K be retained as an operating margin. The remaining 0.5 K is allocated to the heating of the coils by the energy deposition. Two design options have been studied for the cooling of the magnets. The first⁶ is to reduce the size of the bypass holes to force more flow in the annulus between the coil and the beam tube, and the second is to use a cross (radial) flow⁷ arrangement, in which the helium in the bypass is periodically mixed with the annular flow. Both the options result in large pressure drops across the magnet. A bypass diameter (four bypass holes) of 22.5 mm

results in an annular flow of about 12.5 g/s and limits the coil temperature rise to about 0.5 K, which more than satisfies the requirement for 35 W that will be deposited in such a magnet QL1. This creates a pressure drop of about 206 Pa. In the alternative arrangement of cross flow, the yoke has four bypass holes; two of the holes are orificed and helium is forced from one hole. The interfaces between collars and the yoke are arranged in such a way that the flow portions of the flow are diverted into the collar packs and then to the outlet bypass channel. In this arrangement almost all the flow participates in heat removal, and the coil temperature rise will be limited to a maximum of about 0.3 K.

SUMMARY AND ACKNOWLEDGEMENTS

Various magnets, cryostat, and cryogenic distribution designs have been conceptualized for the Interaction Region of the SSC. Detailed design is in progress. It is expected that the designs will meet the requirements. The authors acknowledge the work by various design team members in coming up with these concepts.

REFERENCES

1. Y. Nosochkov et al., "Design of the Interaction Regions at the SSC," 1993 Particle Accelerator Conference, Washington, DC.
2. G. Spigo et al., "Design and Performance of a New 50 mm Quadrupole Magnet for the SSC," 5th Annual International Symposium on the Super Collider, San Francisco, CA (1993).
3. T. H. Nicol, "Design Development for the 50 mm SSC Dipole Cryostat," *Supercollider 3*, ed. J. Nonte, Plenum Press, NY (1991) p. 1029.
4. A. Jalloh et al., "Design and Analysis of the Cryostat System for a 15 m long Prototype Quadrupole Magnet," 5th Annual International Symposium on the Super Collider, San Francisco, CA (1993)
5. V. Venkatraman et al., "Magnetic Design Considerations for a Vertical Bending (BV1C) Magnet," 5th Annual International Symposium on the Super Collider, San Francisco, CA (1993).
6. B. Archer et al., "A Quasi 3D model to Predict Temperature Distribution in SSC Magnets Due to 3D Loads," 5th Annual International Symposium on the Super Collider, San Francisco, CA (1993).
7. R. P. Shutt and M.L. Rehak, "Cross Flow Cooling in SSC Magnets," Brookhaven National Laboratory Report (1990).