

# A 60KV MODULATOR FOR ELECTROSTATIC LENS EXCITATION

A. Fowler, K.-D. Metzmacher

CERN, CH-1211 Geneva 23, Switzerland

## 1. INTRODUCTION

Within the framework of the Laser-Ion Source (LIS) project at CERN, experiments have been performed to characterize a novel low energy beam transport line (LEBT) based on gridded electrostatic lenses [1]. Recent results indicate that emittance blow-up can be limited by the use of such electrostatic lens elements, however, applied d.c. voltage hold-off was limited to 40kV before breakdown occurred. To minimize the probability of breakdown, and allow higher voltages to be applied, a pulsed system is proposed to apply the voltage to the focussing electrodes only during the short period in which the beam is present. A high-voltage modulator, based on semiconductor switching elements, is proposed.

## 2. REQUIREMENTS

High voltage is required on the lenses for a duration of approximately 50 $\mu$ s, with rise and fall times as short as possible. The effective load capacitance presented by each lens is of the order of 500 - 1000pF. The switch circuit must withstand any transient voltage or current spikes induced by breakdown within the electrostatic lenses.

## 3. DESIGN DETAILS

The most obvious choice of circuit to accomplish the requirements is that of a modulator acting as a switch between a high voltage power supply and the load, in this case the effective capacitance of the lens. Whilst it would be possible to charge and maintain the voltage on this capacitance with a single switch, the rapid removal of the voltage requires a second switch. Recent developments in high-voltage semiconductor switches allow a very simple and compact implementation of this circuit; Figure 1 shows a simplified electrical circuit for one lens, in which the gridded electrostatic lens capacitance is represented by C2.

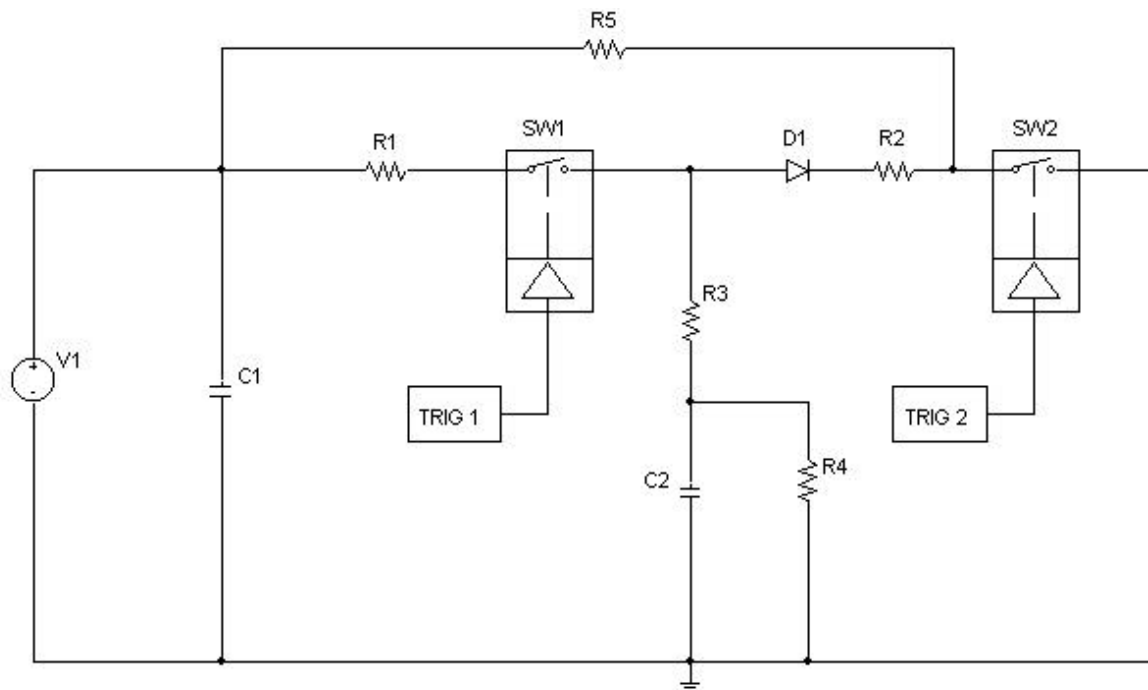

R1 = 1.5k $\Omega$ , R4 = 2M $\Omega$ , C1 = 50nF, SW1 = Behlke HTS 650, option 04 (50 $\mu$ s on-time),  
R2 = 2.2k $\Omega$ , R5 = 150k $\Omega$ , C2 = 500pF, SW2 = Behlke HTS 650, option 03 (100 $\mu$ s on-time),  
R3 = 2.2k $\Omega$ , D1 = 7xUDA10 in series, V1 = FuG HCN 150M-120000 power supply.

Figure 2. Simplified circuit diagram of one electrostatic lens modulator

C1 is charged to a voltage V1. SW1 and SW2 are commercial semiconductor switches (Behlke HTS650) with fixed on-times. Once triggered (by a TTL-level pulse) these switches remain closed for an internally pre-determined period. The turn-off rise time corresponds roughly to the preceding on-time. When the switch SW1 is triggered charge flows from the buffer capacitor C1 onto the electrode capacitance C2. As a result, C2 charged to a voltage very close to the initial voltage on C1 (C1 being two orders of magnitude greater in capacitance than C2). SW2 is triggered after the appropriate flat-top period has elapsed.

Initial tests of the circuit were performed with a dummy load and a negative voltage power supply (owing to the unavailability of a positive voltage unit). The circuit implementation was similar to Figure 1, except that R5 and D2 were absent. Figure 2 below shows measurements from this circuit. SW1 was chosen to have an on-time of 50µs, to satisfy the flat-top duration requirement, and SW2 was chosen to have an on-time of 100µs to allow complete discharge of the load capacitance. It can be seen that upon triggering SW1 a current immediately flowed in both SW1 and SW2, the latter not having been triggered. This spurious operation was found to be caused by the auto-triggering of SW2 by too high an imposed dv/dt across the switch. Equally, upon triggering SW2 it can be seen that SW1 also re-closed and conducted current, again due to dv/dt triggering. This resulted in a two-step rise and a two-step fall of the voltage on the load capacitance, C2. Study of figure 2 reveals that the duration of the self-triggered conduction phase of switch SW2 is not governed by its internally pre-determined timing control, as it extinguishes after only ~50µs. Current in SW2 appears to extinguish slightly before the opening of switch SW1 and thus allows the load to be further charged. The peak voltage is present on C2 only during the period from t = 50µs to t = 100µs and is, in fact, not a stable voltage but exponentially decaying owing to the discharge of C2 through R4 and the fact that the conduction phase of SW1 has timed out. Resistor R4 is included in the circuit for safety reasons; in the event that SW2 does not trigger, C2 will eventually discharge through R4. Operation of the modulator in this manner is clearly not desirable.

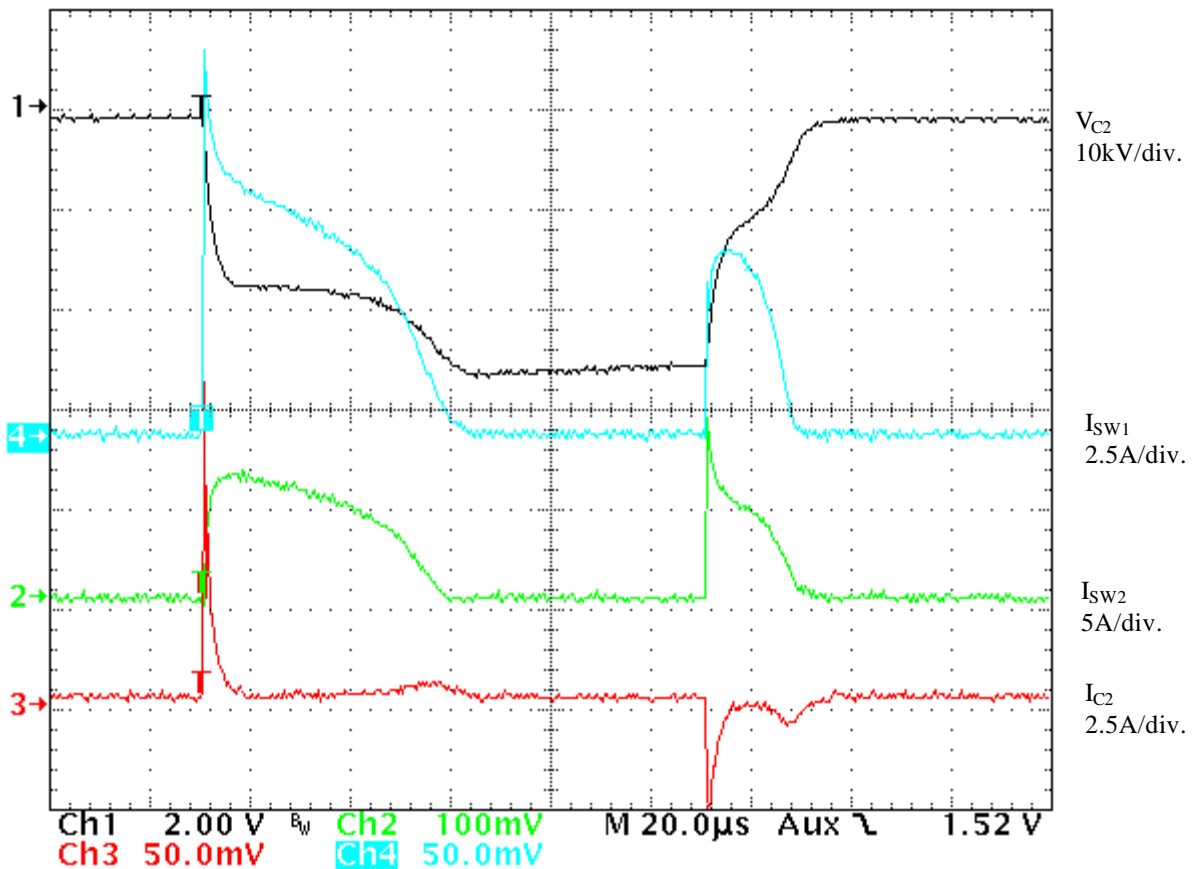
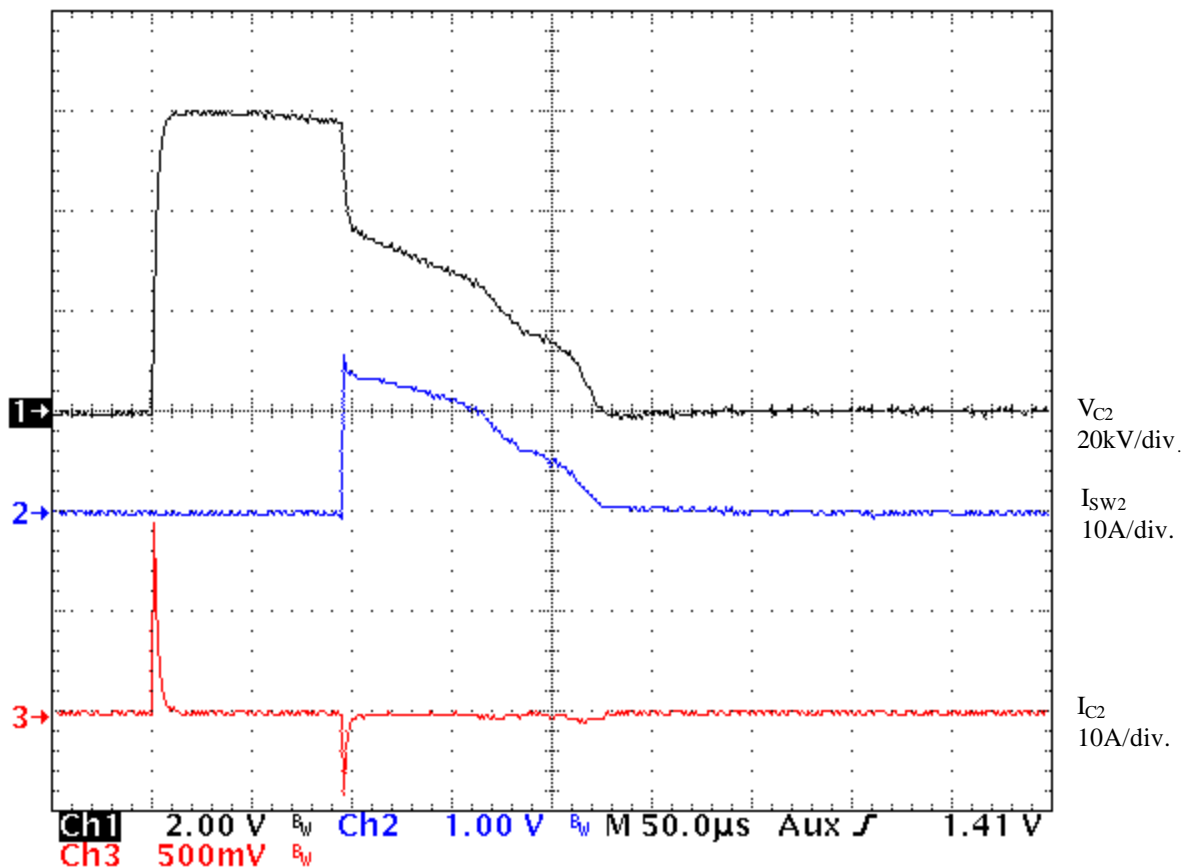

Figure 2. Circuit waveforms with V1 = 30kV

It became apparent that the Behlke HTS650 switches do not have the required transient voltage immunity. An HTS650 with 100µs on-time extension will withstand a dv/dt of only 0.5kV/µs, an HTS650 with 50µs on-time will withstand up to 1kV/µs [2]. The dv/dt seen by the two switches is a function of operating voltage and charge and

discharge time constants. The time constants are primarily determined by the values of R1, R2, R3 and C2. To reduce the dv/dt to acceptable levels, the rise and fall time constants, which were approximately 2μs, would have to be increased by a factor of 60. Given the requirements of the LEBT system, this was not a viable option.

A partial solution was achieved by adding the elements R5 and D2, as shown in Figure 1, which led to the removal of excessive dv/dt across SW2 at the instant of triggering SW1. Resistor R5 feeds forward voltage from the buffer capacitor, whilst diode D2 blocks what would be a charging path to the load capacitor. Figure 3 shows results from this modified circuit. It can now be seen that upon triggering SW1 no current flows in SW2, and the voltage on C2 rises in a single step. However upon triggering SW2 it can be seen that a two-step fall of the voltage occurs on the load capacitance, C2 because SW1 still re-closes due to dv/dt triggering. The current in SW1 could not be measured at 60kV because of insulation problems, however measurements at lower voltages confirmed the re-triggering. The advantage of this circuit is that a stable 60kV flat-top is achieved. The two-step fall of the lens voltage is undesirable, but not disastrous, given the requirements of the modulator. Tests using the actual LEBT experimental set-up will determine if this fall is detrimental to voltage hold-off. A small residual voltage of approximately 1kV can be seen after the modulation has terminated. This is due to the simultaneous conduction of SW1 and SW2, which prohibits complete discharge of C2. This voltage then decays exponentially to zero through R4 within a few milliseconds.



**Figure 3.** Circuit waveforms with V1 = 60kV

It can be seen that the flat-top of the voltage on C2 shown in Fig. 3 comprises two distinct sections. The first is of 50μs duration and although it is exponentially decaying, its very long time constant ( $\tau \approx C1 \cdot R4$ ) renders it essentially flat. This part corresponds to the on-period of SW1. The second section also has an exponentially decaying component, which has a time constant one hundred times shorter ( $\tau \approx C2 \cdot R4$ ), but which is counteracted by a slight recharge of C2 by current flowing through SW1 during its turn-off phase; the former being the dominant component. It was found to be possible to advance the triggering of SW2, thereby shortening the duration of the second section of this flat-top with no apparent detriment to circuit operation. However, providing the longer flat-top period is not detrimental to voltage hold-off in the LEBT system, it is considered prudent to only trigger SW2 once SW1 has completely opened.

#### 4. FUTURE DEVELOPMENTS

A new switch, HTS651, will shortly be released by Behlke which will have an externally-controllable variable on-time. This switch promises greater operational flexibility and higher transient voltage immunity. Tests of the modulator on the LEBT are planned for the near future, and the outcome of these will determine future development.

## 5. SUMMARY

A compact, high-voltage modulator has demonstrated the ability to charge a 500pF capacitive load to 60kV in approximately 10 $\mu$ s, maintain this voltage stable during 50 $\mu$ s, and discharge to nearly zero in a further 170 $\mu$ s.

## 6. ACKNOWLEDGEMENTS

The authors would like to thank Mike O'Neil for his assistance in the tests.

## 7. REFERENCES

[1] P.Fournier *et al*, *Experimental characterisation of Gridded Electrostatic Lens (GEL) Low Energy Beam Transport (LEBT) for the Laser Ion Source (LIS) and effect of a wire grid on the extraction electrode*, PS/HP/Note 99-10 (tech.)

[2]F.Behlke, private communication.