

UNIVERSITÉ PARIS-SUD

ÉCOLE DOCTORAL 517 :
PARTICULES, NOYAUX ET COSMOS

Laboratoire de l'Accélérateur Linéaire (LAL)
Organisation Européenne pour la Recherche Nucléaire (CERN)

THÈSE DE DOCTORAT
Discipline : Physique

par

Oscar Roberto BLANCO GARCÍA

Dynamique des faisceaux dans la section finale
de focalisation du futur collisionneur linéaire

Date de soutenance : 03/07/2015

Composition du jury :

Directeur de thèse	Philip BAMBADE	Directeur de Recherche
Co-encadrant	Rogelio TOMÁS	Physicien au CERN
Examineur	Toshiaki TAUCHI	Professeur Associé
Examineur	Fabien CAVALIER	Professeur
Rapporteur	Jean-Marie DE CONTO	Professeur
Rapporteur	Nobuhiro TERUNUMA	Professeur



Thèse préparée au
Laboratoire de L'accélérateur Linéaire (LAL)
Le Centre Scientifique d'Orsay, Bâtiment 200 BP 34
91 898 Orsay CEDEX, France

financé par,



Centre National de la Recherche Scientifique (CNRS)
Organisation Européenne pour la Recherche Nucléaire (CERN)

Résumé

L'exploration d'une nouvelle physique à l'échelle d'énergie des « Tera electron Volt » (TeV) nécessite de collisionner des leptons dans de grands accélérateurs linéaires à grande luminosité. Ils permettent des mesures de précision avec une statistique suffisante pour analyser les interactions entre les particules. Afin d'atteindre une grande luminosité, les collisionneurs linéaires requièrent une taille de faisceau à l'échelle nanométrique au Point d'Interaction (IP).

Parmi les multiples effets participant à la dégradation de la luminosité, la correction de la chromaticité, l'effet du rayonnement synchrotronique et la correction des erreurs dans la ligne sont parmi les trois effets à maîtriser afin de réduire la taille du faisceau dans la Section Finale de Focalisation (FFS).

Ce travail de thèse traite deux aspects importants pour les collisionneurs linéaires : pousser les limites de la conception du FFS, en particulier la correction de chromaticité et les effets radiatifs importants à 3 TeV, et le travail expérimental et d'instrumentation dans une machine de test pour permettre la stabilisation du faisceau.

Actuellement, les projets de collisionneur linéaire dont le « International Linear Collider » (ILC) [1] et le « Compact Linear Collider » (CLIC) [2] sont étudiés en utilisant des schémas de correction de la chromaticité, pouvant être locale, ou non locale.

Cette thèse propose un nouveau schéma de correction de la chromaticité que l'on appellera "non-entrelacé", appliqué ici au projet CLIC. Lors de l'implémentation de cette nouvelle méthode, il a été mis en évidence que le problème principal est la dispersion du deuxième ordre au Doublet Final (FD), qui traverse un sextupole utilisé pour annuler les composantes géométriques restantes. Cela pourrait être résolu en annulant la dispersion du deuxième ordre et sa dérivée en amont du FD.

L'effet du rayonnement peut être évalué par méthode de tracking des particules ou par des approximations analytiques lors de la conception de la maille. Afin d'inclure ces effets du rayonnement et les paramètres optiques de la ligne pendant la conception et le processus d'optimisation, l'effet Oide [3] et le rayonnement dû aux aimants dipolaires [4] ont été étudiés.

Le résultat analytique du rayonnement synchrotronique dans les aimants dipolaires [4] fut généralisé dans les cas où le paramètre Twiss α et dispersion sont non-nulles à l'IP. Cette généralisation est utilisée pour améliorer le code de simulation PLACET [5] en le comparant avec la solution particulière pour un aimant dipolaire et un aimant dipolaire plus une section droite. La limite théorique du rayonnement d'un photon en moyenne par particule pourrait causer une différence de $\pm 10\%$ entre le code de simulation et la théorie pour les aimants dipolaires dans le FFS de CLIC.

Le rayonnement dans les aimants quadripolaires finaux impose une limite à la taille verticale minimale du faisceau, connue comme l'effet Oide. Cette effet est uniquement important à 3 TeV, donc deux possibilités sont explorées pour atténuer sa contribution à la taille du faisceau : doubler la longueur et réduire le gradient du dernier quadripole (QD0), ou intégrer une paire d'aimants octupolaires, un en amont et un en aval du QD0. Une réduction de 4% est obtenue dans la taille du faisceau, cependant, l'effet sur la luminosité est négligeable.

Une partie des exigences du FFS pour les nouveaux collisionneurs linéaires à leptons, en particulier pour ILC, est testée expérimentalement dans l'« Accelerator Test Facility » (ATF), au laboratoire KEK (Japon). La réduction de la taille du faisceau d'électrons en utilisant le schéma local de correction de la chromaticité est explorée dans une extension de la ligne originale, appelée ATF2, dont les objectifs : (**but 1**) atteindre 37 nm de taille verticale du faisceau à l'IP, et (**but 2**) stabiliser à l'ordre du nanomètre la position verticale du faisceau à l'IP.

Depuis 2014, une taille de 44 nm avec un nombre de particules d'environ 0.1×10^{10} par paquet est atteinte de manière régulière. Des mesures de position du faisceau basés sur des cavités de radio-fréquence sont utilisés pour détecter le déplacement/des fluctuations du faisceau et permettre aussi sa stabilisation.

Un ensemble de trois cavités (IPA, IPB et IPC) sur deux systèmes de déplacement à base d'actionneurs piezo-électriques installées est utilisé pour mesurer la trajectoire du faisceau dans la région de l'IP, fournissant ainsi des informations pour reconstruire la position et l'angle à l'IP. Les spécifications pour l'optique nominale d'ATF2, i.e. 1 nm de résolution sur $10 \mu\text{m}$ de gamme dynamique à un nombre de particules de 1.0×10^{10} par paquet, n'ont pas encore été atteintes.

La meilleure résolution atteinte jusqu'ici correspond à 50 nm pour 0.4×10^{10} particules par paquet, où le bruit de l'électronique impose une limite de 10 nm par cavité sur la résolution. La gamme dynamique est de $10 \mu\text{m}$ à 0.4×10^{10} particules par paquet moyennant une atténuation du signal des cavités de 10 dB. La calibration des cavités dans le plan vertical indique une linéarité de l'ordre de quelques percent sur deux ordres de grandeur d'atténuation du signal. L'intégration de ces cavités dans

l'ensemble des instruments utilisés pour le réglage d'ATF est en cours. Le test du système d'asservissement pour stabiliser le faisceau a atteint une réduction des fluctuations jusqu'à 67 nm RMS, compatible avec la résolution des système de mesure.

Deux améliorations ont été faites sur le système après ces études. En premier lieu, les plans horizontaux et verticaux pourront être analysés simultanément. En second lieu, des filtres ont été intégrés au système pour réduire l'effet de la disadaptation en fréquence dans le processus de « down-mixing » des signaux.

Mots-clefs : Collisionneur de leptons, accélérateur linéaire, Section Finale de Focalisation (FFS), Point d'Interaction (IP), Méthode de correction de la chromaticité non-entrelacé, effet Oide, rayonnement synchrotronique, aimans dipolaires, ATF2, CLIC, ILC, IPBPMs, stabilisation du faisceau, monitor de position du faisceau (BPM).

Abstract

The exploration of new physics in the ‘‘Tera electron-Volt’’ (TeV) scale with precision measurements requires lepton colliders providing high luminosities to obtain enough statistics for the particle interaction analysis. In order to achieve design luminosity values, linear colliders feature nanometer beam spot sizes at the Interaction Point (IP).

In addition to several effects affecting the luminosity, three main issues to achieve the beam size demagnification in the Final Focus Section (FFS) of the accelerator are the chromaticity correction, the synchrotron radiation effects and the correction of the lattice errors.

This thesis considers two important aspects for linear colliders: push the limits of linear colliders design, in particular the chromaticity correction and the radiation effects at 3 TeV, and the instrumentation and experimental work on beam stabilization in a test facility.

The current linear collider projects, CLIC [2] and ILC [1], have lattices designed using the local or non-local chromaticity correction schemes.

A new chromaticity correction scheme, called non-interleaved, is proposed to the local and non-local chromaticity corrections for CLIC. This lattice is designed and diagnosed, where the main issue in the current state of lattice design is the non-zero second order dispersion in the Final Doublet (FD) region where a strong sextupole is used to correct the remaining geometrical components. It could be solved by cancelling the second order dispersion and its derivative before the FD.

The radiation effect can be evaluated by tracking particles through the lattice or by analytical approximations during the design stage of the lattices. In order to include both, radiation and optic parameters, during the design optimization process, two particular radiation phenomena are reviewed: the Oide effect [3] and the radiation caused by bending magnets [4].

The analytical result of the radiation in bending magnets in [4] was generalized to the case with non-zero alpha and non-zero dispersion at the IP, required during the design and luminosity optimization process. The closed solution for one dipole and one dipole with a drift is compared with the tracking code PLACET [5], resulting in the improvement of the tracking code results. The low number of average photons emitted per particle could show $\pm 10\%$ difference in the beam size contribution from radiation calculated with the tracking code and the theory for the dipoles used in the CLIC FFS design.

In the Oide effect, radiation in the final quadrupole sets a limit on the vertical beamsizes. Only for CLIC 3 TeV this limit is significant, therefore two possibilities are explored to mitigate its contribution to beam size: double the length and reduce the QD0 gradient, or the integration of a pair of octupoles before and after QD0. A beam size reduction of 4% is achieved, however, the impact in the luminosity is negligible.

Part of the requirements of the FFS for new linear accelerators, in particular ILC, are tested in The Accelerator Test Facility (ATF). The beam size reduction using the local chromaticity correction is explored by an extension of the original design, called ATF2 with two goals: (**goal 1**) achieve 37 nm of vertical beam size at the IP and (**goal 2**) the stabilization of the IP beam position at the level of few nanometres. Since 2014 beam size of 44 nm are achieved as a regular basis at charges of about 0.1×10^{10} particles per bunch.

A set of three cavities (IPA, IPB and IPC), two upstream and one downstream of the nominal IP and on top of separate blocks of piezo-electric movers, were installed and are used to measure the beam trajectory in the IP region, thus providing enough information to reconstruct the bunch position and angle at the IP. These will be used to for beam stabilization and could detect beam drift/jitter beyond the tolerable margin and undetected optics mismatch affecting the beam size measurements.

The specifications required of 1 nm resolution over 10 μm dynamic range at 1.0×10^{10} particles per bunch with the ATF2 nominal optics have not been yet achieved.

The minimum resolution achieved is just below 50 nm at 0.4×10^{10} particles per bunch with a set of electronics imposing a noise limit on resolution of 10 nm per cavity. The dynamic range is 10 μm at 10 dB attenuation and 0.4×10^{10} particles per bunch, indicating the need to upgrade the electronics. The results of the studies in the vertical plane of the cavities calibration show linearity within 5% over two orders of magnitude of signal attenuation. The integration to the ATF tuning instruments is ongoing. Nonetheless, feedback has been tested resulting in reduction of beam jitter down to 67 nm, compatible with resolution.

Two improvements have been done on the system since this study. First, the horizontal and vertical planes can be analyzed simultaneously, such that data can be checked for coupling from one

plane to another. Second, filters are added to the system in order to reduce the effect of the mismatch between frequencies in the electronics down-mixing process.

Keywords: Lepton collider, linear accelerator, Final Focus Section (FFS), Interaction Point (IP), non-interleaved chromaticity correction, Oide effect, synchrotron radiation, bending magnets, ATF2, CLIC, ILC, IPBPMs, beam stabilization, Beam Position Monitor (BPM).

Remerciements

I would like to thank my two directors, Philip Bambade and Rogelio Tomás, for their continuous encouragement to pursue the exploration of new ideas for linear colliders.

I would like also to thank the ATF staff, KNU and Oxford colleagues for their clear disposition and the exchange of ideas inside and outside the control room.

Finally, I would like to thank the LAL and CERN people I met or came across during the last three years. I've been always looking forward to exchange some words to make life simpler.

For Claire.

Contents

I	The Linear Colliders	20
1	Introduction	21
1.1	The high energy exploration	21
1.1.1	Circular or linear colliders	22
1.2	Purpose of a linear collider	23
1.2.1	Physics in e^+e^- colliders	23
1.2.2	Rate of events	23
2	Linear Collider Concepts	25
2.1	Main Parts of a linear collider	25
2.2	The Final Focus Section (FFS)	25
2.3	Overview of FFS effects	26
2.3.1	Chromaticity	26
2.3.2	Pinch effect and Beamstrahlung	28
2.3.3	Crossing angle	29
2.3.4	Hourglass effect	29
2.3.5	Synchrotron Radiation	29
2.3.6	Tolerances	30
3	Current Linear Collider Projects	31
3.1	Compact Linear Collider (CLIC)	31
3.2	International Linear Collider (ILC)	32
3.3	Test Facilities	33
II	Final focus design for small beam size	38
4	Chromaticity in the FFS	39
4.1	Chromaticity minimization in the Final Doublet (FD)	39

4.2	The non-interleaved lattice	44
4.2.1	Introduction	44
4.2.2	Geometric Terms Cancellation	44
4.2.3	The Lattice	45
4.2.4	Conclusion	47
5	Radiation in Bending Magnets	49
5.1	Theoretical approximation	49
5.1.1	Generalization of the optimization process	50
5.1.2	One dipole and one dipole with a drift	51
5.2	Comparison of theory and tracking results	51
5.3	Model limitations	54
5.4	Validity for the FFS	54
6	Oide effect	57
6.1	Beam size limit	57
6.2	Oide Double Integral Solution	58
6.3	Mitigating the impact on the beam size	59
6.3.1	QD0 length	59
6.3.2	Correctors	60
6.3.3	Conclusions	63
III	BPMs at the ATF2 Interaction Point (IPBPMs)	65
7	Relevance of ATF/ATF2	67
7.1	Facility purpose	67
7.2	Beam line Description	68
7.2.1	The RF Gun and Linac	69
7.2.2	The Damping Ring	69
7.2.3	The extraction line	69
7.2.4	The extraction diagnostic section	70
7.2.5	The ATF2 lattice	70
7.2.6	The IP Region	70
7.3	Beam Size Measurement at the IP	72
7.4	Beam stabilization	73
7.4.1	Tuning	73

7.4.2	Feedback	73
7.5	Recent achievements and current work	74
7.6	Position Measurement Requirements	74
8	BPMs System description	77
8.1	The system	77
8.1.1	The cavities	78
8.1.2	The processing electronics	81
8.1.3	Feedback system	83
8.1.4	The acquisition system	83
8.2	BPM Analysis Method	84
8.2.1	Waveform analysis	84
8.2.2	Position scans	84
8.2.3	Angle scans	85
8.2.4	Jitter acquisitions	85
9	System characterization and Preliminary Results	89
9.1	Calibration	89
9.1.1	Movers' Calibrations C_m	89
9.1.2	Cavity response calibration C_c	93
9.2	Dynamic Range	94
9.2.1	Acquisition System	94
9.2.2	Processing electronics and cavity sensitivity	94
9.3	Resolution	95
9.3.1	Acquisition System	95
9.3.2	Noise floor and cavity sensitivity	95
9.3.3	Resolution by trajectory reconstruction	96
9.4	Feedback	99
9.5	Present Status and Prospects	99
IV	Conclusions, Results and Perspectives	102
A	The primitive \mathcal{F}	105
B	IPBPMs Movers	109
B.1	System Description	109

B.1.1	The Piezo Movers	109
B.1.2	Electrical connections	109
B.1.3	The PLC	111
B.1.4	The PC	112
B.2	The BPMs	113
B.2.1	Coordinate system	113
B.2.2	Alignment adjustment	115
B.3	Alignment	115
B.3.1	Vacuum chamber	115
B.3.2	Effect of alignment on dynamic range	116
B.3.3	Effect of cavity alignment on calibration	116
B.3.4	Mechanical BPM alignment	117
	Bibliography	119

List of Figures

1.1	The electromagnetic and electro-weak forces unify at the Terascale.	21
1.2	Cross section of Higgs production as a function of \sqrt{s} for $m_h = 120$ GeV.	24
2.1	Chromaticity. Particles with off-momentum energy are focused at different longitudinal locations increasing the beam size.	26
2.2	Non-local chromaticity correction.	28
2.3	Local chromaticity correction.	28
3.1	CLIC schematic layout.	34
3.2	CLIC 3 TeV FFS.	35
3.3	CLIC 500 GeV FFS.	35
3.4	ILC 500 GeV FFS.	35
3.5	ILC schematic layout.	36
4.1	FD with focal points IM and IP at different distances.	39
4.2	Normalized transversal functions (4.2a) β_{x1}/β_{x0} , (4.2b) β_{y1}/β_{y0} , (4.2c) Ξ_x , (4.2d) Ξ_y	41
4.3	CLIC 3TeV (4.3a) $\Xi(\beta_x^*/\beta_y^*, r, r_{im})$, (4.3b) β_{x1}/β_{y0} , (4.3c) β_{x1}/β_{y1}	42
4.4	CLIC 500GeV (4.3a) $\Xi(\beta_x^*/\beta_y^*, r, r_{im})$, (4.4b) β_{x1}/β_{y0} , (4.4c) β_{x1}/β_{y1}	43
4.5	Non-interleaved chromaticity correction.	44
4.6	Sextupoles joined by the transport matrix T_{12}	45
4.7	Phase advance in the non-interleaved lattice design.	45
4.8	Non-interleaved lattice design for CLIC 500 GeV. Dipoles in blue, horizontally focusing quadrupoles in red and above the axis, vertically focusing quadrupoles in red and below the axis, and sextupoles in black.	46
4.9	Beam size at the IP of the CLIC 500 GeV non-interleaved design as a function of transfer map order obtained with MAD-X PTC.	47
4.10	CLIC 500 GeV non-interleaved lattice. The second order dispersion from the T_{166} map component is not zero at the sextupole in the FD.	47

5.1	Beam size increase due to radiation normalized to closed expression assuming negligible energy loss. (Left) ‘Default’ radiation option, (Right) ‘Six_dim’ option in PLACET 0.99.01. Plots (a) and (b) correspond to $L = 10$ m for a dipole only. Plots (c) and (d) correspond to $\theta = 10^{-4}$ rad for a dipole only. Plots (e) and (f) correspond to $L = 10$ m and $\theta = 10^{-4}$ rad while varying the drift length. Beam energy is 1500 GeV in all cases.	53
5.2	Result from tracking, closed expression with the mean number of photons emitted by particle superimposed. Magnetic field is fixed at 5×10^{-3} T and $E = 1500$ GeV.	54
6.1	Design particle trajectory in blue and the trajectory of a particle due to radiation in the quadrupole in red.	57
6.2	Oide effect beam size contribution for CLIC 3 TeV design parameters. (a) σ_{oide}^2 normalized to designed linear beam size as a function of quad length for the minimum focusing k (when $\alpha_y = 0$ at the quadrupole opposite side to the IP), for k calculated as thin lens ($k = \frac{1}{Ll^*}$) and the current QD0. (b) k in the three previous cases for comparison.	60
6.3	Oide effect beam size contribution for CLIC 500 GeV design parameters. (a) σ_{oide}^2 normalized to designed linear beam size as a function of quad length for the minimum focusing k (when $\alpha_y = 0$ at the quadrupole opposite side to the IP), for k calculated as thin lens ($k = \frac{1}{Ll^*}$) and the current QD0. (b) k in the three previous cases for comparison.	60
6.4	CLIC 3 TeV beam at the IP after tracking through QD0 with and without radiation.	61
6.5	Correlation between the phase space coordinates $\Delta y, y'$ for CLIC 3 TeV from particle tracking and theoretical expression in Eq. (6.9).	61
6.6	For the nominal trajectory in blue, the kick in C1 must cancel the kick in C0. For all particles that radiate in red, the difference in kicks should cancel Δy	62
6.7	β functions and β_y/β_x ratio for CLIC 3 TeV FD, QF1 and QD0 in red on top. The dark area is occupied by QD0 and the IP is at $s = 0$	62
7.1	Diagrams containing the ATF composition and a zoom on the ATF2 section.	68
7.2	Optical functions in the Final Focus Section at ATF2. On top is the ATF2 lattice: dipoles in blue, quadrupoles in red and sextupoles in black.	71
7.3	Vertical and horizontal beam sizes for 1BY, 1000BY, and 0.5BY in the vertical plane, and 1BX, 10BX and 100BX in the horizontal plane.	72
7.4	IPBSM schematic design. The particle beams cross the interference pattern generated by a perpendicular laser beam. The number of electron-photon interactions varies with the fringe size and the particle beam size.	72
7.5	(Right) IPBSM laser path over the optical table perpendicular to the beam propagation. (Left) Beam size resolution for the angle modes : $2 \sim 8^\circ$ in green, 30° in blue and 174° in red.	73
8.2	Dipolar and monopolar mode in rectangular cavities.	78
8.3	Monopolar mode in cylindrical cavities.	78
8.4	Coupling to the dipole mode of the cavity.	79

8.5	Processing electronics per BPM per plane.	82
8.6	Limiter detector.	82
8.7	IQ rotation. The blue dots represent the systematic change in position.	84
9.1	Movers calibration test setup for the vertical plane.	90
9.2	Block AB movers, linearity test over four cycles.	91
9.3	Block AB movers minimum step and stability.	91
9.4	Horizontal to vertical coupling of movers motion.	91
9.5	Block C movers, linearity test over four cycles.	92
9.6	Stability at fixed voltage setting.	92
9.7	Horizontal to vertical movers coupling.	93
9.8	Calibrations as a function of attenuation.	93
9.9	Effect of attenuation in Q' signals from calibrations. Error bars are RMS.	94
9.10	IPBy Calibration versus charge normalized to the calibration at minimum charge.	95
9.11	Jitter measurement for the 3 BPMs.	96
9.12	Three BPM resolution. The position measurement at IPA and IPB are used to extrapolate to IPC. The residual from subtraction of the measured and extrapolated position at IPC is used to estimate the system resolution.	97
9.13	Correlation of the three BPMs measurements and predictions.	98
B.1	Piezo mover system connection diagram.	110
B.2	Control system per mover.	111
B.3	BPM coordinate system centered ellectrically. Beam in red, BPMs in green.	114
B.4	Reference system for the 3 BPMs.	114
B.5	Set of movers: M_{01234} in Block IPAB and M_{BCDE} in Block IPC.	114
B.6	Longitudinal position of the movers.	115
B.8	γ angle rotation over the BPM. The only effect on distance measured is to add γ to β	118

List of Tables

1.1	Luminosity of the lepton colliders.	24
2.1	Luminosity and beamstrahlung for the three current linear collider projects. . .	29
3.1	CLIC Beam Parameters.	31
3.2	ILC Beam Parameters.	32
4.1	Approximative vertical chromaticity for the three current linear collider projects.	44
4.2	CLIC 500 GeV parameters used for the non-interleaved lattice design.	46
5.1	Bending angles in CLIC 3 TeV.	55
5.2	Bending angles in CLIC 500 GeV.	55
6.1	Vertical beam size and radiation beam size contribution for three lattices. ϵ_N is the normalized emittance, $\epsilon_N = \gamma\epsilon$	58
6.2	Effect of octupolar correctors on the beam size, total luminosity and peak luminosity.	63
7.1	Design parameters of ILC and ATF2 Final Focus. †The ILC lattice has two detector options: SiD and ILD.	67
7.2	Basic design parameters of the ATF injector linac.	69
7.3	ATF DR main parameters.	69
7.4	Vertical beam size at the cavities positions and the IP with the 1000BY optics.	75
7.5	Vertical beam size at the cavities positions and the IP with the 1BY optics. . .	75
8.1	Measured decay time for the three cavities before installation.	81
8.2	Resonant dipole frequency measurement at KEK before installation.	81
8.3	Jitter at beam waist with 1BX1BY optics.	86
8.4	Jitter at beam waist with 10BX1BY optics.	87
8.5	Jitter at IP with 1BX1BY optics.	87
8.6	Jitter at IPA with 10BX1BY optics.	87
9.1	Results from trajectory reconstruction.	99

9.2	IPBPMs status.	100
B.1	Movers setting to adjust position and pitch angle. $M_{0123,BCDE} \in [-1, 1]$	115
B.2	Alignment measurement using $I' = 0$	116
B.3	Alignment measurement using $I' = 0$ and $Q' = 0$ for previous BPMs.	116
B.4	Position mechanical precision	117

Part I

The Linear Colliders

Chapter 1

Introduction

1.1 The high energy exploration

According to [6], the triumph of the 20th century particle physics was the development of the Standard Model. Experiments determined the particle constituents of ordinary matter, and identified four forces binding matter and transforming it from one form to another. This success leads particle physicist to address even more fundamental questions, and explore deeper mysteries in science.

The Standard Model includes a third component beyond particles and forces, the Higgs mechanism. The Higgs mechanism permeates the universe, giving mass to the particles, and breaking the electro-weak force in two, the electromagnetic and the weak forces.

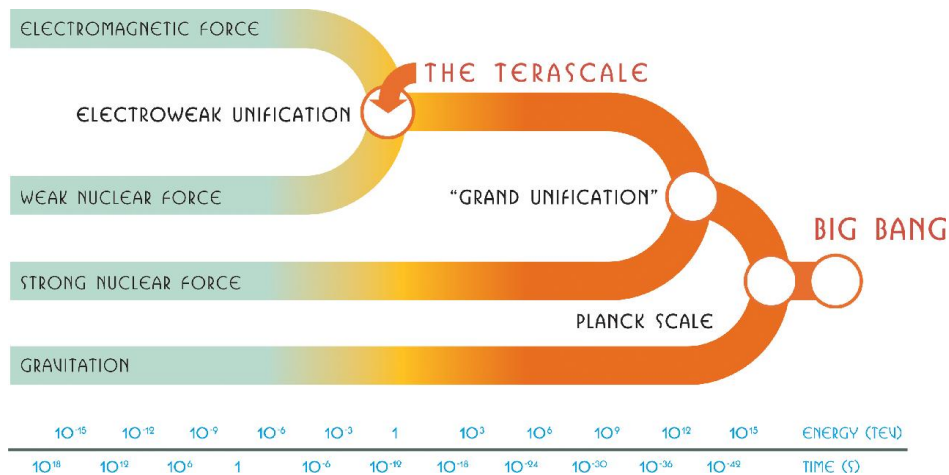

Figure 1.1 – The electromagnetic and electro-weak forces unify at the Terascale.

Experiments in the Terascale could test the idea that fundamental forces originate from a single unified force, see Fig. 1.1, and search for evidence of a related unified origin of matter involving supersymmetry. They could distinguish among patterns of phenomena to judge different unification models, providing a telescopic view of the ultimate unification.

There are two ways to explore the subatomic world, the first is to go to higher energy to discover new particles and measure their properties, the second is to increase the precision of the measurements to detect rare processes and make detailed studies.

The LHC allows the exploration of the electroweak symmetry breaking mechanism and other

physical phenomena at the TeV scale, like the CP violation problem, the quark gluon plasma at the search of new physics beyond the Standard Model such as supersymmetry (SUSY) among others.

The future linear collider beam energy will be determined by the LHC discoveries. The following is a list of those mentioned in [7].

Higgs searches: The 4th of July of 2012, in a seminar held at CERN, the collaborations of the Experiments CMS and ATLAS presented an update of the Higgs of the Higgs searches status. At a confidence level of 4.9σ for CMS [8], and 5.1σ for ATLAS [9] from the Higgsless Standard Model, signals of a boson with a mass around $m_h = 125$ GeV were found with a strong spin-0 indication and coupling parameters consistent with the properties of the Standard Model Higgs Particle. First results on various rare production decay modes have been obtained but more data is needed to observe these models. Many analyses are ongoing and more updates are constantly presented.

Heavy Flavour and CP Violation: The experiments of the LHC, led by the LHCb, have carried out several important findings and measurements in the heavy flavour sector. New previously unobserved states have been observed for the very first time during the last years like the states X_b , Ξ_a and Λ_s^0 . Also the measurement of the quantum numbers of the states $X(3872)$ with $J^{PC} = 1^{++}$, have been determined to the 8σ level. The CP violation of the oscillation in D and B mesons have been measured to the 9.1σ confidence level discovering the same violation in B_s systems. The CP angle γ is known with a precision without precedents ($\gamma = (67 \pm 12)^\circ$). Finally, some very rare decays like $B_s \rightarrow \mu^+\mu^-$, $B^0 \rightarrow K^*\mu^+\mu^-$ and $D_s^+ \rightarrow \pi^+\mu^+\mu^-$ have been observed, with possible implications on the analysis of new physics.

Quark-gluon Plasma: The quark-gluon plasma is produced in ultra-relativistic heavy ion collisions. The conditions observed at the LHC experiments (ALICE, ATLAS and CMS) are in agreement with the observations carried out at RHIC. It has been confirmed that the hydrodynamics model helps in the understanding of the behaviour of the processes occurred during the collision. It is still far from being completely understood.

SUSY and Dark Matter searches: One of the problem that arises is the stabilization of the Higgs mass and its divergence when quantum divergence is considered. The solution involves a new principle of nature called supersymmetry (SUSY), a new symmetry that unifies bosons and fermions. After data collected during 2011 and 2012, SUSY searches at the LHC did not find any evidence of any light superpartner (squark or gluino) and it has pushed their mass limits beyond 1 TeV with the constrained model [10].

The Second run of the LHC at 13 TeV will provide more information about the physics at high energies.

1.1.1 Circular or linear colliders

Higher energies have been usually explored with hadron colliders and the precision measurements has been done by lepton colliders, however, lepton circular colliders are limited by radiation. When particles traverse magnetic fields they emit photons and this photons make the beam loose energy per turn given by

$$\Delta E_{turn} = \frac{E^4}{3\rho m_0^4 c^8} \quad (1.1)$$

where m_0 is the rest mass of the particle, c is the speed of light, ρ is the curvature radius to the trajectory produced by the magnet and E is the beam energy. The highest energy lepton

collision, 209 GeV, have been reached with electron and positron colliding beams in LEP at CERN. In spite of the 27 km circumference of LEP the beam energy was limited by synchrotron radiation losses, just compensated by a powerful superconducting RF system providing up to 3640 MV per revolution [11].

1.2 Purpose of a linear collider

The physics potential of future linear colliders has been studied since the Stanford Linear Collider (SLC) [12, 13]. The advantage of a linear lepton collider with respect to the LHC is the cleanliness of the events where two elementary particles with known kinematics and spin define the initial state. The resulting precision of the measurements is achievable because of the high resolution possible in the detector due to background processes well calculated and measured, a clean experimental environment, ability to scan systematically in c.o.m energy, possibility of high degree of polarization, and possibility for $\gamma\gamma$, e^-e^- , $e^-\gamma$ collisions.

1.2.1 Physics in e^+e^- colliders

The confirmation of the Standard Model has been achieved through a combination of analyses from LEP, SLC, HERA, B-factories, Tevatron and the LHC and the gauge structure $SU(3)_C \times SU(2)_L \times U(1)_Y$. In this model the Higgs mechanism is responsible for the electroweak symmetry breaking and the masses of other particles.

A linear collider can be used to conclude if the boson found at LHC has the properties predicted by the Standard Model or if it is part of an extended Higgs sector as in SUSY [14, 15, 16]. Figure 1.2 shows the cross section of the Higgs boson production mechanisms as a function of the c.o.m energy of the e^+e^- collision.

One other aspect is that a linear collider can study the presence of composite structure of the Higgs particle and can measure precisely the electroweak coupling of the top quark by directly measuring the top quark mass.

A linear collider can also be used to explore the Kaluza-Klein theory of an extra-space dimension where gravitons propagate, and the deep study of couplings and spins in SUSY if there is signs of their existence in the LHC run 2.

1.2.2 Rate of events

Although cosmic rays could be of large energies, a large number of particle detections is required to obtain enough statistics to confirm the validity of a theory, therefore the need of a collider.

Luminosity, L , is proportional to the number of collisions that are produced when two beams cross each other. The expression that relates luminosity, cross section σ and the number of events produced R is given by,

$$R = L\sigma \tag{1.2}$$

Luminosity will depend on the bunch population n_b (assuming an equal number of particles for both beams) and their density distribution within the bunches.

Linear colliders require to minimize the beam size at the Interaction Point (IP) of the two beams to recover the luminosity L of a circular collider. Equation (1.3) highlights the dependence with beam size in the transversal planes, where f_{rep} is the repetition frequency of

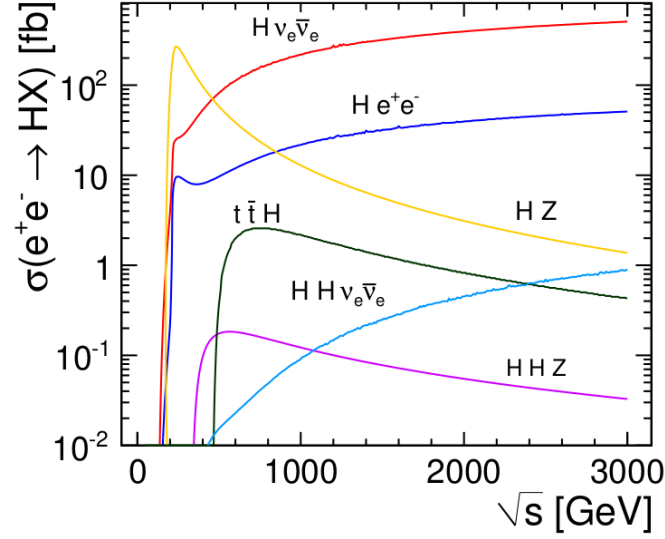

Figure 1.2 – Cross section of Higgs production as a function of \sqrt{s} for $m_h = 120$ GeV.

the two particle bunches collision, E is the beam energy, and σ_x and σ_y are the horizontal and vertical beam sizes.

$$L \propto \frac{f_{rep} n_b^2}{\sigma_x \sigma_y} \quad (1.3)$$

Table 1.1 shows how the beam size is decreased in the linear colliders SLC [17], CLIC [2] and ILC [1] (last two to be introduced in Section 3), to compensate lower repetition rate and charges when compared with the circular collider LEP [18]. Horizontal beam size is larger than vertical beam size in lepton colliders to preserve luminosity while mitigating the beam-beam effect called beam strahlung, explained in Section 2.3.2.

Parameter, Symbol, [Unit]	LEP	SLC	ILC	CLIC 500 GeV	CLIC 3 TeV
Energy/ e^- , E , [TeV]	0.1046	0.050	0.250	0.250	1.500
Bunch population, n_b	1.7×10^{11}	3.3×10^{10}	2×10^{10}	6.8×10^9	3.72×10^9
Repetition rate, f_{rep} , [Hz]	11.2×10^3	120	5	50	50
H/V. IP beam size, σ_x/σ_y , [nm]	$(200/2.5) \times 10^3$	$(2.1/0.6) \times 10^3$	474/5.9	202/2.3	40/1
Luminosity, L , [$\text{cm}^{-2} \cdot \text{s}^{-1}$]	2.1×10^{31}	0.8×10^{30}	1.57×10^{34}	2.3×10^{34}	5.9×10^{34}

Table 1.1 – Luminosity of the lepton colliders.

Chapter 2

Linear Collider Concepts

2.1 Main Parts of a linear collider

The current two main linear accelerator projects, the International Linear Collider (ILC)[1] and the Compact Linear Collider (CLIC)[2], are composed by similar main parts:

- **Electron and Positron Sources:** is a laser driven photo-injector. The photons illuminate a GaAs cathode producing an electron current. Positrons are produced by electrons guided through a helical undulator. The photons illuminate a target to produce e^-e^+ pairs. The positrons are selected by deviating their trajectory with a magnet.
- **Damping Rings:** The pre-accelerated electron and positron beams are injected into the damping rings, composed of superconducting wigglers, to make the beam radiate thus reducing the beam emittances to reach the small beam sizes in the collision.
- **Main Linac:** After the emittance reduction the beam passes through a chain of accelerating structures to increase the particles energy up to the design value while preserving as best as possible the normalized emittance.
- **Beam Delivery System (BDS):** is the beam transport system from the linac acceleration section to the collision at the IP. Its main purpose is the beam diagnose and collimation, and also the beam size reduction in a subsection called Final Focus Section (FFS).

The main purpose of this work is related to the FFS and the IP region, thus, it will be explained in detail in the following sections.

2.2 The Final Focus Section (FFS)

In the Final Focus Section (FFS) the goal is to minimize the beam size. If the lattice is conceived as a telescope where the matrix elements are as in Eq. (2.2), being M_x, M_y the magnifications in horizontal and vertical planes, then, beam size to the first order does not depends on the beam energy spread δ . Considering the second and third order components in the transfer map, as in Eq. (2.3), then, the telescope properties show that the main contribution to beam size is chromaticity ξ_x given by the elements T_{126} , and T_{346} [19], identified in [7] as

$$\xi_x = \frac{1}{\beta_x^*} \left(4T_{116}^2 \beta_{x0} + 4T_{126}^2 \frac{1}{\beta_{x0}} \right) \quad \xi_y = \frac{1}{\beta_y^*} \left(4T_{336}^2 \beta_{y0} + 4T_{346}^2 \frac{1}{\beta_{y0}} \right) \quad (2.1)$$

being the 0-index the values at the input, *-index the values at the output, and $T_{346} = T_{364}, T_{126} = T_{162}$. For this reason, the FFS has been conceived as a telescope to demagnify the beam size with minimum effect of energy spread, where the main issue is the large chromaticity generated at the Final Doublet (FD), the last pair of quadrupoles which focus the beam at the Interaction Point (IP).

$$R = \begin{pmatrix} M_x & 0 & 0 & 0 \\ 0 & 1/M_x & 0 & 0 \\ 0 & 0 & M_y & 0 \\ 0 & 0 & 0 & 1/M_y \end{pmatrix} \quad (2.2)$$

$$x_i = \sum_{j=1}^6 R_{ij}x_j + \sum_{j,k=1}^6 T_{ijk}x_jx_k + \sum_{j,k,l=1}^6 U_{ijkl}x_jx_kx_l + \dots \quad x_i \in x, x', y, y', \tau, \delta \quad (2.3)$$

2.3 Overview of FFS effects

2.3.1 Chromaticity

As in the case of light beams through lenses, the longitudinal focal point location depends on the beam energy spread. This effect is called chromaticity. Figure 2.1 represents schematically the focusing effect of a magnet as a lens. A particle with the design momentum crossing the lens at a distance y_0 from the center will be focused at l^* . Off-momentum particles with higher or lower momentum will be under-focused or over-focused, respectively. This produces a variation in the transverse position at the focal distance l^* increasing the beam size.

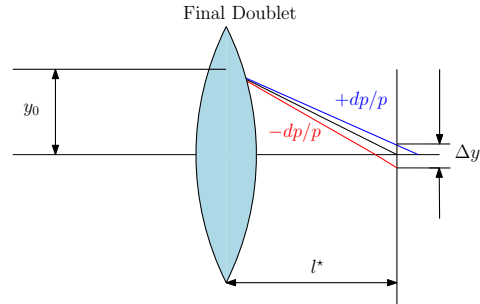

Figure 2.1 – Chromaticity. Particles with off-momentum energy are focused at different longitudinal locations increasing the beam size.

The effect on the beam size is commonly estimated as

$$\frac{\Delta y_{rms}^*}{\sigma_y^*} \approx \frac{l^*}{\beta^*} \sigma_\delta \approx \xi_y \sigma_\delta \quad (2.4)$$

where l^* is the focal length, σ_δ is the second moment of the energy spread distribution, β_y^* is the optical β function at the focal position and ξ_y is the chromaticity.

The chromatic dilution of the beam size can be expressed as

$$\sigma_y^* \approx \sigma_{y,0} \sqrt{1 + \xi_y^2 \sigma_\delta^2} \quad (2.5)$$

where $\sigma_{y,0}$ is the transverse beam size with zero energy spread.

An study of minimum chromaticity generation in the FD is presented in Section 4.1.

Chromaticity correction

In the thin lens approximation with a vertically focusing quadrupole magnet of thickness ds , the kick in angle given to a crossing particle is expressed in [20] as

$$dx' = k_q(1 - \delta)xds \quad dy' = -k_q(1 - \delta)yds \quad (2.6)$$

where dx' , dy' are the horizontal and vertical angle kick respectively, k_q is the quadrupole gradient and $\delta = dP/P_0$ is the energy spread. A combination of bending magnets and sextupoles is used to subtract the extra kick due to energy spread.

First, horizontal position and energy are correlated by dispersion, η_x , generated by bending magnets [20]. This divides the particle motion in two parts: the betatron motion and an offset equal to $\eta_x\delta$. Equation (2.7) shows the coordinate transformation.

$$\begin{aligned} x &\rightarrow x_\beta + \eta_x\delta \\ y &\rightarrow y_\beta \end{aligned} \quad (2.7)$$

Then, sextupoles are located in dispersive regions ($\eta_x \neq 0$) to kick the particles cancelling the quadrupole angle kick dependence on δ . The quadrupole and sextupoles kicks in dispersive region are in Eq. (2.8), where k_s is sextupole gradient.

$$\begin{aligned} \text{Quadrupole:} \quad dx' &= k_q(1 - \delta)(x_\beta + \eta_x\delta)ds & dy' &= -k_q(1 - \delta)y_\beta ds \\ \text{Sextupole:} \quad dx' &= \frac{1}{2}k_s[(x_\beta + \eta_x\delta)^2 + y_\beta^2]ds & dy' &= -k_s(x_\beta + \eta_x\delta)y_\beta ds \end{aligned} \quad (2.8)$$

The chromatic terms, $k_q x_\beta \delta$ and $k_q y_\beta \delta$, are cancelled by matching k_q and $k_s \eta_x$.

The geometric terms introduced by the sextupole, $\frac{1}{2} k_s (x_\beta^2 + y_\beta^2)$ and $k_s x_\beta y_\beta$, are cancelled by another sextupole, both separated by a transport matrix equal to $-I$ transformation, being I the identity transport matrix.

The remaining terms are cancelled by a combination of bending magnets and sextupoles location and strengths. Two methods have been develop to achieve the cancellation all second order terms: the non-local correction and the local correction. A third method has been recently introduced, called the non-interleaved correction.

Non-local correction: The non-local correction scheme [21] compensates upstream the chromaticity in the Final Doublet (FD). Figure 2.2 shows schematically the lattice configuration, where QF1 and QD0 constitute the FD, B0 to B5 are dipole magnets to produce horizontal dispersion, SD and SF sextupoles are used to cancel vertical and horizontal chromaticity respectively.

The chromatic terms, $k_q x_\beta \delta$ and $k_q y_\beta \delta$, are cancelled by making $k_q = k_s \eta_x$.

The term $k_q \eta_x \delta$ disappears because the final doublet is in a non-dispersive region.

The second order dispersion generated by the sextupoles, $\frac{1}{2} k_s \eta_x \delta^2$, is cancelled by matching the dispersion and sextupole strengths in the $-I$ transformation.

Local correction: The local chromaticity correction scheme [22] compensates chromaticity inside the FD and Fig. 2.3 shows the sextupoles locations.

The non-zero dispersion in the FD generates an offset on the quadrupole horizontal focusing center, $x = x_\beta + \eta_x \delta$.

The second order dispersion, $k_q \eta_x \delta^2$ and $\frac{1}{2} k_s \eta_x \delta^2$, is half cancelled if $k_q = k_s \eta_x$. One solution is to double the sextupole strength and produce the entire chromaticity upstream in a non-dispersive region.

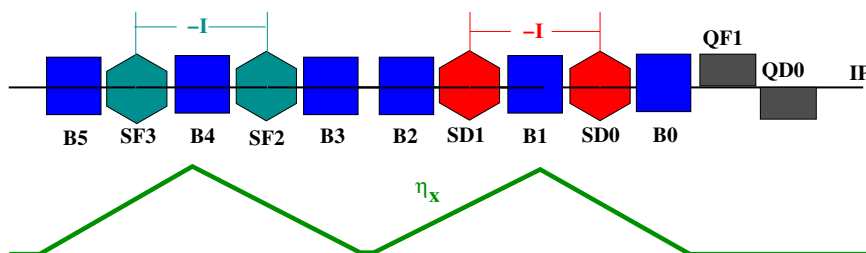

Figure 2.2 – Non-local chromaticity correction.

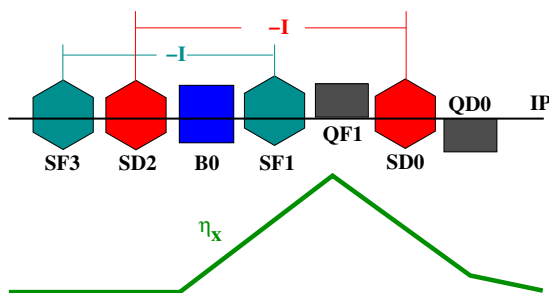

Figure 2.3 – Local chromaticity correction.

Non-interleaved correction: The non-interleaved correction scheme is presented in Section 4.2.

2.3.2 Pinch effect and Beamstrahlung

The electric charge interaction between bunches when the two bunches cross one another at the IP produces focusing for opposite charges and defocusing when bunches are of the same charge. This is called pinch effect. The change of trajectory leads to a loss of energy of the particles, called beam strahlung [23].

The pinch effect could be used to determine the beam-beam relative offset because of the change in angle of the out-going trajectory after the interaction [24]. On the other hand, although the focusing effect increases the luminosity for bunches with opposite charge, the energy spread generated by the interaction reduces luminosity. This requires to separate the luminosity in total luminosity and peak luminosity.

The peak luminosity only accounts for those interactions between particles with at least 99% of the nominal energy, while total luminosity accounts interactions at all energies.

Linear colliders require to minimize the beam size at the IP of the two beams to increase luminosity while also limiting the energy loss due to beamstrahlung δ_{BS} . Equation (2.9) highlights the dependence with beam size in the transverse planes, where f_{rep} is the repetition frequency of the two particle bunches collision, E is the beam energy, and σ_x and σ_y are the horizontal and vertical beam sizes.

$$L \propto \frac{f_{rep} N_e^2}{\sigma_x \sigma_y} \quad \delta_{BS} \propto \frac{N_e^2 E}{(\sigma_x + \sigma_y)^2} \quad (2.9)$$

Table 1.1 shows how the beam size is decreased in all current linear collider projects, introduced in Section 3, to compensate lower repetition rate and charges. In addition, horizontal beam size is larger than vertical beam size to preserve luminosity while reducing the beam strahlung effect.

Parameter, Symbol, [Unit]	ILC	CLIC 500 GeV	CLIC 3 TeV
Energy/ e^- , E [TeV]	0.250	0.250	1.500
Bunch population, N_e	2×10^{10}	6.8×10^9	3.72×10^9
Repetition rate, f_{rep} , [Hz]	5	50	50
H/V. IP beam size, σ_x/σ_y , [nm]	474/5.9	202/2.3	40/1
E loss (Beamstrahlung), δ_{BS} , $[\Delta E/E]$	0.07	0.07	0.28
Luminosity, L , $[\text{cm}^{-2}\cdot\text{s}^{-1}]$	1.57×10^{34}	2.3×10^{34}	5.9×10^{34}

Table 2.1 – Luminosity and beamstrahlung for the three current linear collider projects.

2.3.3 Crossing angle

It is necessary to introduce a crossing angle between the two beam lines to avoid the near encounters of the in-going and out-going bunches. For beams without pinch effect the effect on luminosity for a crossing angle α is given by [25]

$$\frac{L}{L_0} = \frac{1}{\sqrt{1 + \left(\frac{\sigma_z}{\sigma_x} \tan \frac{\alpha}{2}\right)^2}} \quad (2.10)$$

where σ_z and σ_x are the longitudinal and horizontal beam sizes. The luminosity can be restored by rotating the beam using a crab cavity [26].

2.3.4 Hourglass effect

To consider the beam size constant along the whole collision length in some cases is not a good approximation because of the beam divergence due to the strong focusing. In a low- β region near the IP, the beam size is

$$\sigma(s) = \sigma^* \sqrt{1 + \left(\frac{s}{\beta^*}\right)^2} \quad (2.11)$$

where s is the longitudinal position centered in the IP, and σ^* is the beam size at the IP. This is important because not all particles will collide with minimum transverse beam size along the bunch length σ_z , affecting the luminosity [27]. The optimum β_y^* that maximizes the luminosity is $\beta_y^* \approx \sigma_z$.

2.3.5 Synchrotron Radiation

Synchrotron radiation in the FFS increases the beam size [4] thus affecting the luminosity, and can form background in the detector [23]. The beam size contribution from synchrotron radiation is studied in Section 5. The photons contributing to background should be collimated before they reach the detector.

Synchrotron radiation in the FD is dangerous because the photons can not be collimated in front of the detector. To avoid any hitting the first and second quadrupole in the opposite line one must collimate the beam to achieve safe beam size. The Synchrotron radiation in the FD also contributes to beam size, and it limits the minimum vertical size achievable. Section 6 presents the effect of the closest quadrupole to the IP, QD0.

2.3.6 Tolerances

The FFS has very tight tolerances because of the small beam size at the IP. Magnet strengths, position and tilt yield imperfections contribute the beam size growth.

The tuning is the procedure which brings the system performance to its design values. Since the initial errors are unknown, the tuning requires a statistical study. Usually more than 100 machines with randomly distributed errors are considered in computer simulations. The simulated tuning reproduces a realistic tuning procedure in a machine [7, 28].

Chapter 3

Current Linear Collider Projects

3.1 Compact Linear Collider (CLIC)

The CLIC [2] is designed to collide electrons and positrons at 3 TeV c.o.m. with total luminosity of $6 \times 10^{34} \text{ cm}^{-2}\text{s}^{-1}$. The innovative proposal of two-beam acceleration is explored to accomplish the high accelerating gradient of the order of 100 MV/m. The RF power is extracted from a low-energy and high-intensity beam, the drive beam, and fed into the main beam via Power Extraction and Transfer Structures (PETS). This concept reduces the length of the accelerating system compared to superconducting technology.

The CLIC studies were initially concentrated in 3 TeV, with a 500 GeV stage. Table 3.1 shows the main beam parameters and Fig. 3.1 show the 500 GeV and 3 TeV layouts. Recently the CLIC 500 GeV has been reconsidered due to the 125 GeV mass boson founded by the LHC experiments CMS and ATLAS, concluding a new CLIC stage at 380 GeV c.o.m.

The most critical areas for the CLIC design the ability to achieve the 100 MV/m accelerating gradient, the generation, stabilization and deceleration of the drive beam, the ultra-low emittances in the damping rings and their preservation up to the collision point, the ability to protect the machine to damage, and the beam size minimization.

Parameter, Symbol, [Unit]	CLIC 3TeV	CLIC 500 GeV
Center of mass, E_{cm} , [GeV]	3000	500
Repetition rate, f_{rep} , [Hz]	50	50
Bunch population, N_e	3.72×10^9	6.8×10^9
Number of bunches, n_b	312	354
Bunch separation, Δt_b , [ns]	0.5	0.5
Accelerating gradient, G , [MV/m]	100	80
Bunch length, σ_z , [μm]	44	72
IP Beam size, σ_x, σ_y , [nm]	40/1	200/2.26
Normalized beam emittance (IP), $\epsilon_{nx}/\epsilon_{ny}$, [nm]	600/20	2400/25
Total Luminosity, L_{tot} , [$10^{34}\text{cm}^{-2}\text{s}^{-1}$]	5.9	2.3
Site length, [km]	48.3	13.0

Table 3.1 – CLIC Beam Parameters.

The CLIC 3TeV and 500 GeV FFS has been studied in [7] with local and non-local chromaticity correction and concluded that the non-local is longer about 1 km longer than the local but only for high energies. At low energies both require a similar length. Both achieve a similar luminosity, however, the main difference come from tuning simulations where the

non-local shows easier tuning at high energies, which translates to larger integrated luminosity and larger statistics for the particle physics analysis. Figure 3.2 shows the non-local and local chromaticity correction lattices for 3 TeV and Fig. 3.3 for the 500 GeV case.

3.2 International Linear Collider (ILC)

The ILC [1] is designed to have a continuous center-of-mass energy range between 200 MeV and 500 GeV, and peak luminosity $L = 2 \times 10^{34} \text{ cm}^{-2}\text{s}^{-1}$, consistent with producing 500 fb^{-1} in the first four years of operation. In addition, the machine should be upgradable to a center-of-mass of 1 TeV. It has been designed to achieve and energy stability and precision of 0.1 %, and to have 80% electron polarization at the IP as well as an option for 60% positron polarization. Furthermore, alternative options for $\gamma\gamma$ and e^-e^- collisions are under consideration.

The main technological challenge in ILC is based in 1.3 GHz superconducting radio frequency accelerating cavities with gradient of 31.5 MV/m each. One other challenge is the beam minimization due to the tight tolerances to obtain nanometer vertical beam size.

Figure 3.5 shows the ILC schematic layout and Table 3.2 shows the chosen beam parameters for ILC such that each subsystem accomodates a range of beam parameters, resulting in flexible operating parameters that will allow identified problems in one area to be compensated for in another.

Parameter, Symbol, [Unit]	ILC
Center of mass, E_{cm} , [GeV]	500
Repetition rate, f_{rep} , [Hz]	5.0
Bunch population, N_e	20×10^9
Number of bunches, n_b	1312
Bunch separation, Δt_b , [ns]	554
Accelerating gradient, G , [MV/m]	31.5
Bunch length, σ_z , [μm]	300
IP Beam size, σ_x, σ_y , [nm]	474/5.9
Normalized beam emittance (IP), $\epsilon_{nx}/\epsilon_{ny}$, [nm]	10000/35
Total Luminosity, L_{tot} , [$10^{34}\text{cm}^{-2}\text{s}^{-1}$]	1.8
Site length, [km]	31

Table 3.2 – ILC Beam Parameters.

The ILC FFS is shown in Fig. 3.4. It follows the local chromaticity correction scheme using sextupoles interleaved with the FD. The dispersion, η_x , at the IP is zero and its derivative, $\eta'_x = \partial\eta_x/ds$, the angular dispersion is about 0.009. The horizontal and vertical sextupoles are interleaved generating third order geometrical aberrations partially corrected by additional sextupoles in proper phase. The residual higher order aberrations are minimized by octupoles and decapoles. The main difference between the CLIC FFS and the ILC FFS design is the presence of dedicated octupoles for the non-linear handling of the beam tails in ILC.

An study of the CLIC FFS for the ILC lattice has been carried out in [7] by reoptimizing the lattice to the nominal requirements and introducing a traveling waist [29] in ILC to increase the luminosity compensating the hourglass effect.

3.3 Test Facilities

Several Test Facilities have been constructed for the required linear colliders R&D. The following is a brief description of the facility purpose [7].

- **CLIC Test Facility 3 (CTF3)**: was built at CERN in Geneva, Switzerland, to demonstrate the CLIC two-beam acceleration concept. This requires the high energy acceleration of two beams and the stable deceleration of the drive beam.
- **Final Focus Test Beam (FFTB)**: was built and operated during the 90's at SLAC in California, The United States of America, to reduce the beam size following the non-local chromaticity correction. The smallest vertical beam size measured was 70 nm.
- **Accelerator Test Facility (ATF)**: was built at KEK in Tsukuba, Japan, to reduce the beam emittance and vertical beam size following the local chromaticity correction. The emittance goal has been already achieved and vertical beam sizes down to 44 nm are obtained by systematic tuning of the lattice. This is further explained in Section 7.

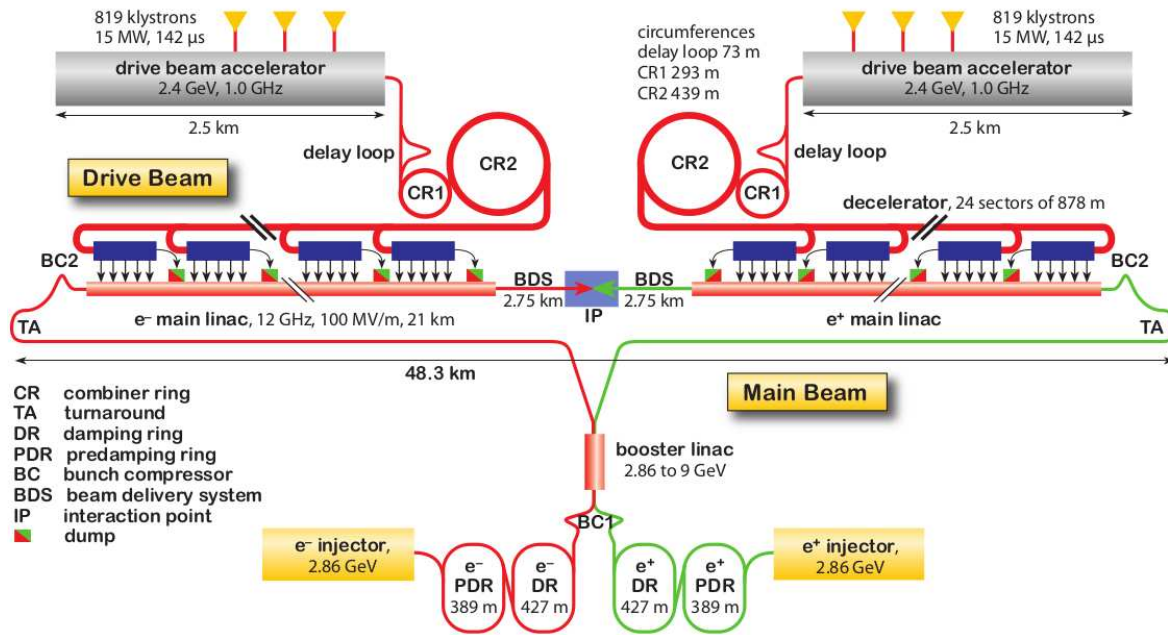

(a) CLIC 3TeV layout.

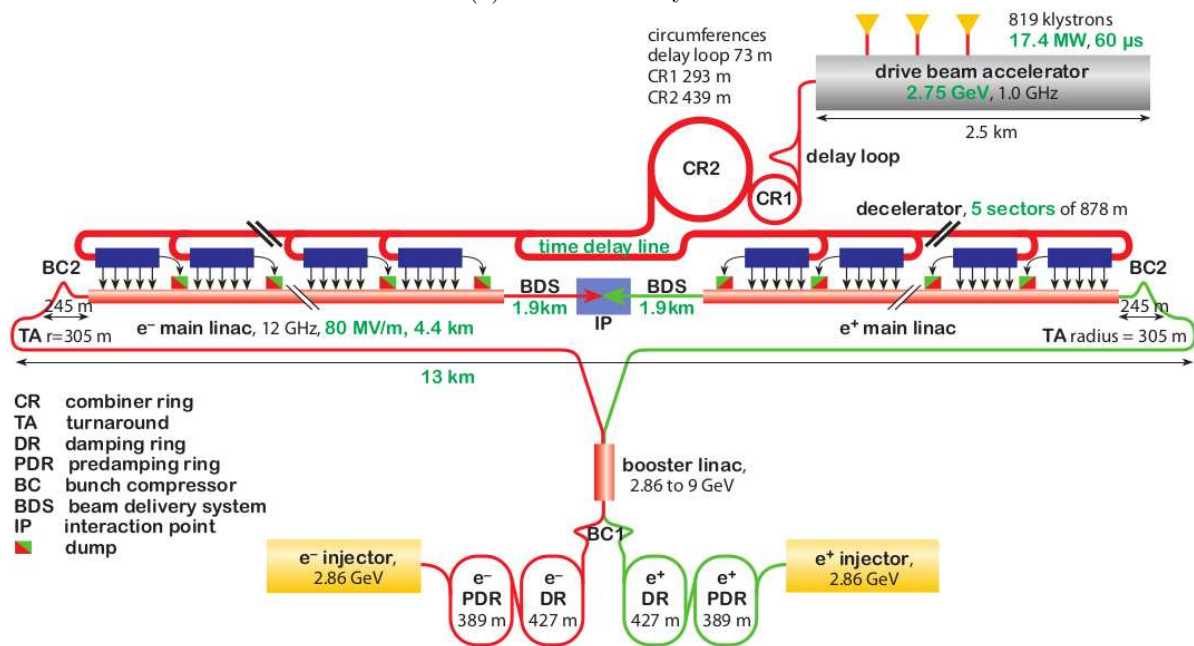

(b) CLIC 500 GeV layout.

Figure 3.1 – CLIC schematic layout.

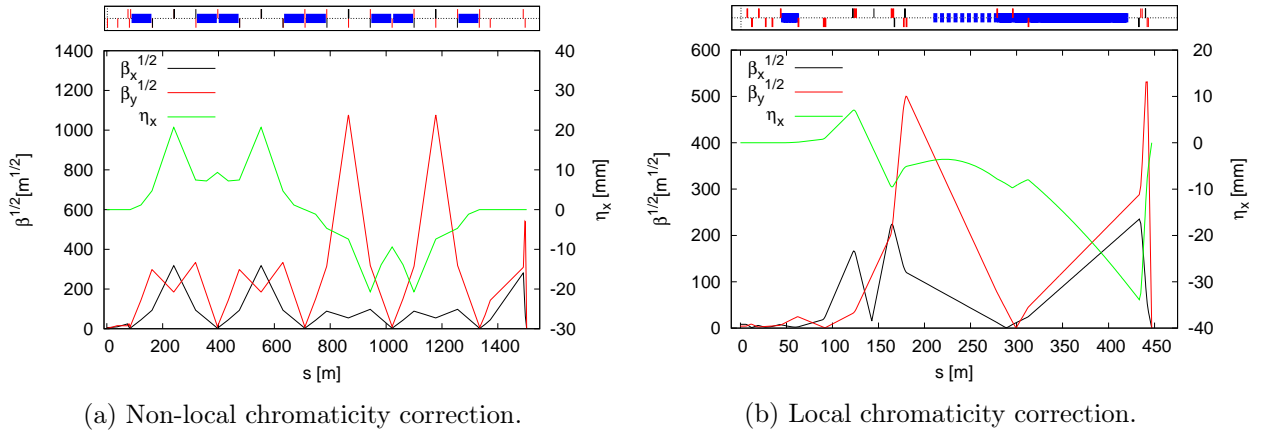

Figure 3.2 – CLIC 3 TeV FFS.

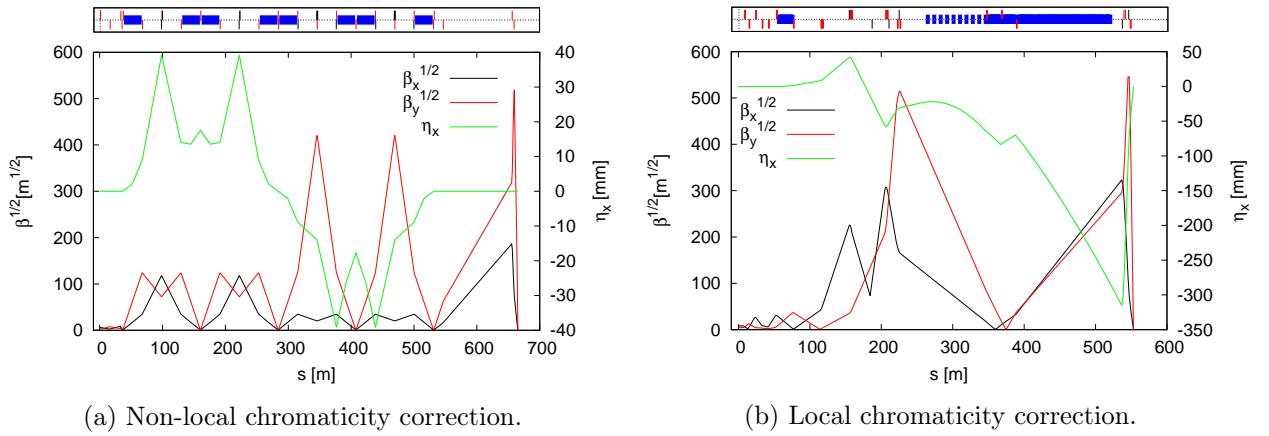

Figure 3.3 – CLIC 500 GeV FFS.

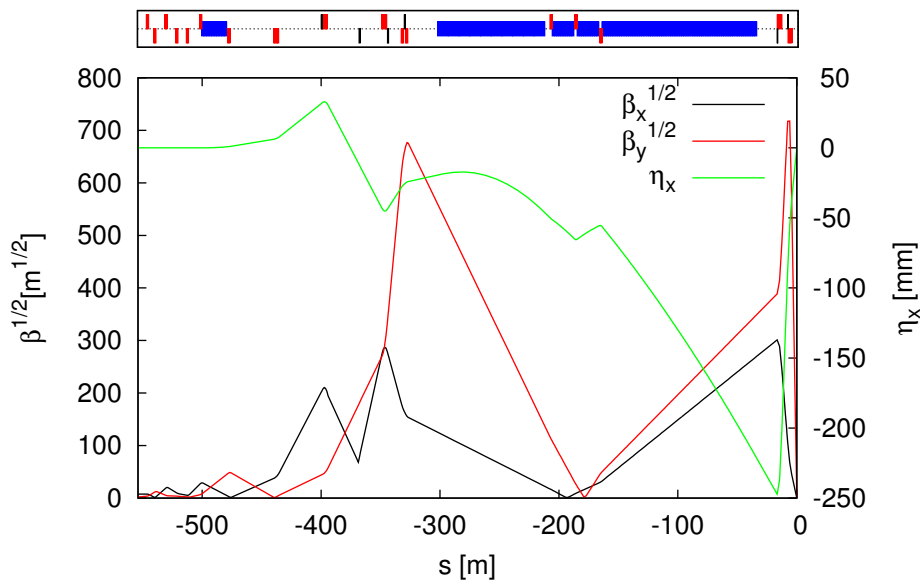

Figure 3.4 – ILC 500 GeV FFS.

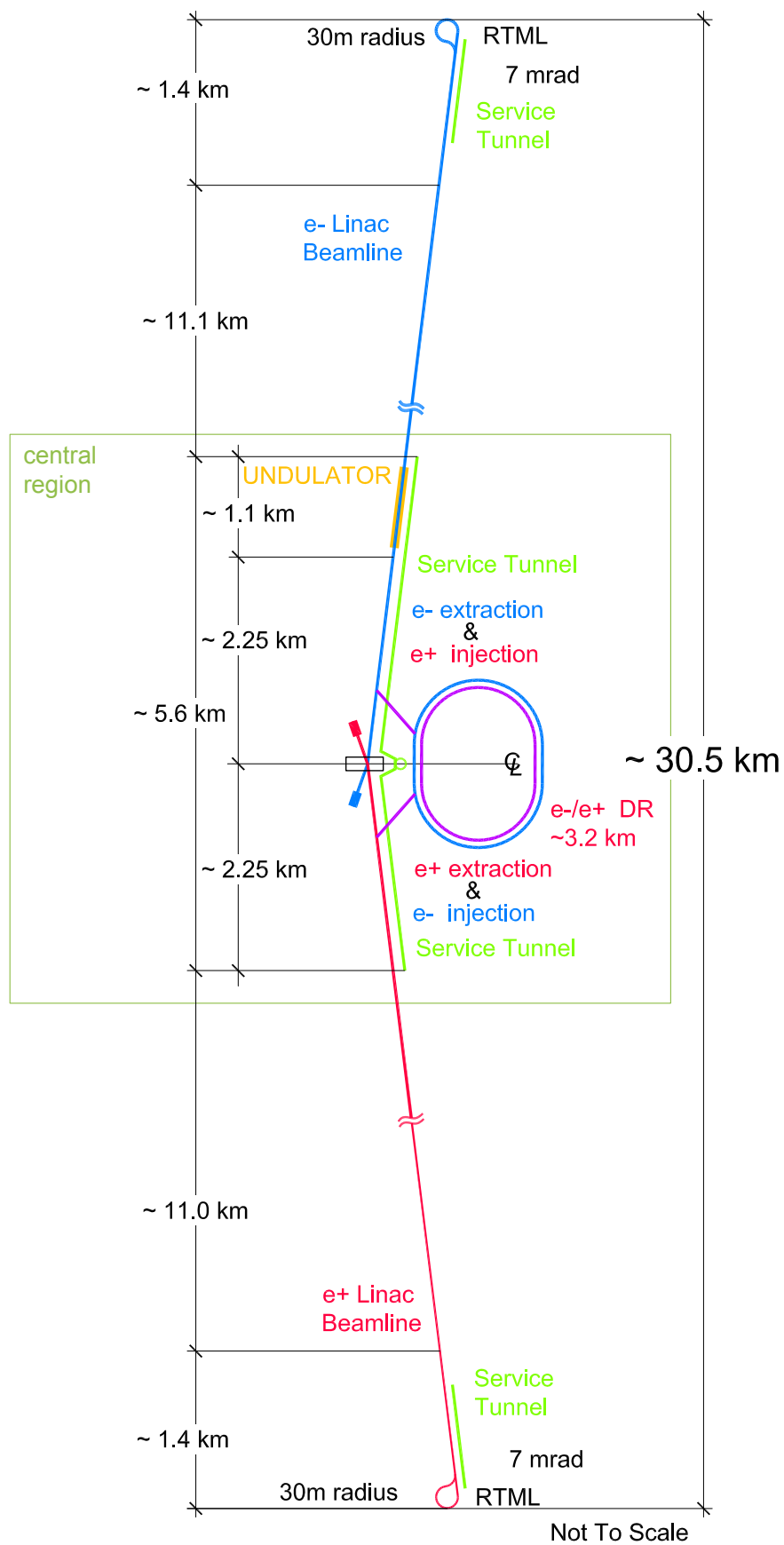

Figure 3.5 – ILC schematic layout.

Part II

Final focus design for small beam size

Chapter 4

Chromaticity in the FFS

4.1 Chromaticity minimization in the Final Doublet (FD)

In this Section I find the Final Doublet distance that minimizes the chromaticity.

In the thin lens approximation, an FD as in Fig. 4.1, with $r = L/L_{IP}$ and $r_{im} = L_{IM}/L_{IP}$, has peak β -functions at the quadrupoles equal to $\beta_{y0} = \frac{L_{IP}^2}{\beta_y^*}$ for QD0 and

$\beta_{y1} = \beta_{y0} \left(1 + r \pm \sqrt{\frac{r}{r_{im}} + r + \frac{r^2}{r_{im}} \sqrt{\frac{1+r}{1+r/r_{im}}}}\right)^2$ for QF1, using $\left(\frac{\beta^*}{L_{IP}}\right)^2 \ll 1$, i.e. a small β function far from QD0. The factor β_{y1}/β_{y0} is the beta function at QF1 relative to QD0.

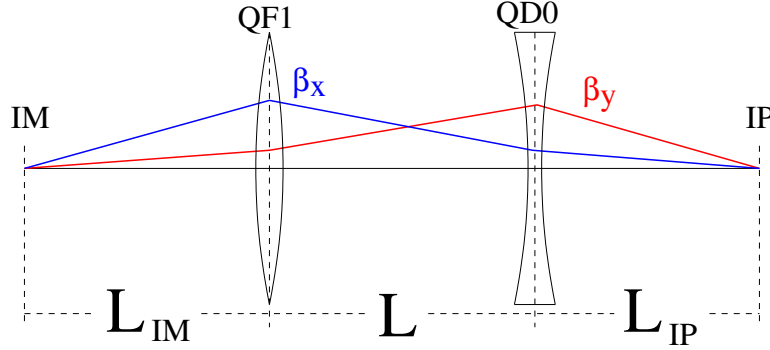

Figure 4.1 – FD with focal points IM and IP at different distances.

Being the chromaticity for a single quadrupole as in Eq. (4.1) from [7],

$$\xi_y^x = \int \beta_y^x(s) k(s) ds \quad (4.1)$$

where the k is the quadrupole gradient and s the longitudinal coordinate, then, ξ_y^x can be evaluated as

$$\xi_y^x = \mp \left(\beta_{y1}^x k_1 l_1 - \beta_{y0}^x k_0 l_0 \right) = \frac{L_{IP}}{\beta_y^* \Xi_y^x(r, r_{im})} \quad (4.2)$$

where k, l are the quadrupole gradient and length, β^* is the β function at the IP, the indexes indicate the quadrupole and

$$\Xi_y^x(r, r_{im}) = \mp \sqrt{\frac{1}{rr_{im}} + \frac{1}{r} + \frac{1}{r_{im}} \sqrt{\frac{1+r/r_{im}}{1+r}}} \left[\left(1 + r \pm \sqrt{\frac{r}{r_{im}} + r + \frac{r^2}{r_{im}} \sqrt{\frac{1+r}{1+r/r_{im}}}} \right)^2 - \left(\frac{1+r}{1+r/r_{im}} \right) \right] \quad (4.3)$$

Figure 4.2 show the chromaticity Ξ_x and Ξ_y in L_{IP}/β^* units, and the ratio of the β functions at the quadrupoles.

In order to minimize the product of dispersion and sextupole strengths used to subtract the quadrupoles chromatic effect, explained in Section 2.3.1, one possibility is to minimize the sum of the horizontal and vertical chromaticities, i.e. the total chromaticity to be corrected. Being the sum,

$$\xi = \xi_x + \xi_y = \frac{L_{IP}}{\beta_y^*} \left(\frac{\Xi_x(r, r_{im})}{\beta_x^*/\beta_y^*} + \Xi_y(r, r_{im}) \right) \quad (4.4)$$

$$= \frac{L_{IP}}{\beta_y^*} \Xi(\beta_x^*/\beta_y^*, r, r_{im}) \quad (4.5)$$

Figure 4.3 shows Ξ for CLIC 3 TeV, $\beta_x^*/\beta_y^* = 6.9\text{mm}/0.068\text{mm} = 101$, and Fig 4.4 is the equivalent for CLIC 500 GeV [2], $\beta_x^*/\beta_y^* = 8.0\text{mm}/0.1\text{mm} = 80$.

Given L_{IM} , the minimum added chromaticity in the FD is found when L is one to two times the distance to the IP. In addition, Figs. 4.3-4.4 show the effect of scaling up the system. For example, starting at $L = L_{IP}$ and $L_{IM} = 10L_{IP}$, it is clear that a system with $L = 10L_{IP}$ and $L_{IM} = 100L_{IP}$, will decrease the vertical chromaticity by increasing the horizontal chromaticity.

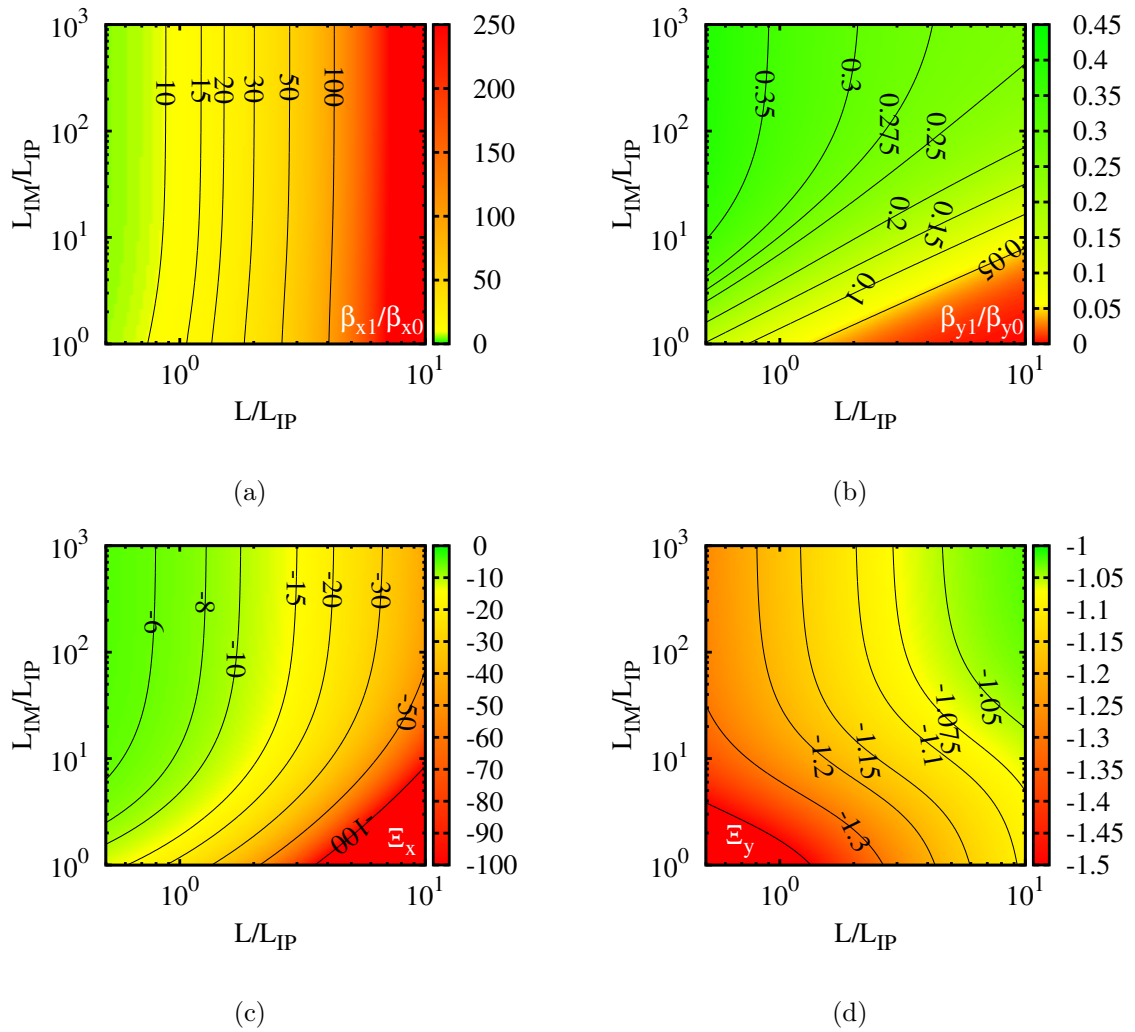

Figure 4.2 – Normalized transversal functions (4.2a) β_{x1}/β_{x0} , (4.2b) β_{y1}/β_{y0} , (4.2c) Ξ_x , (4.2d) Ξ_y

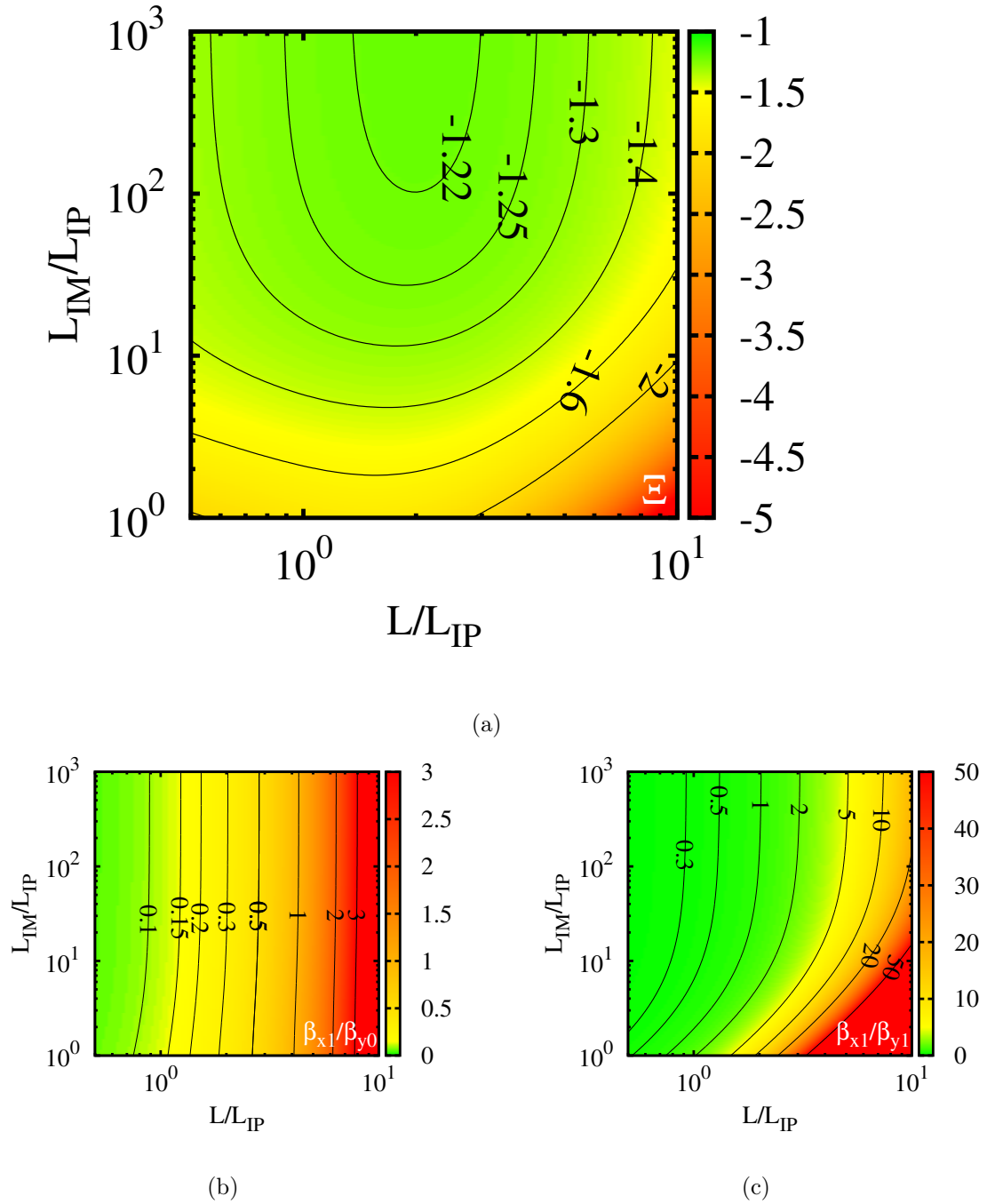

Figure 4.3 – CLIC 3TeV (4.3a) $\Xi(\beta_x^*/\beta_y^*, r, r_{im})$, (4.3b) β_{x1}/β_{y0} , (4.3c) β_{x1}/β_{y1}

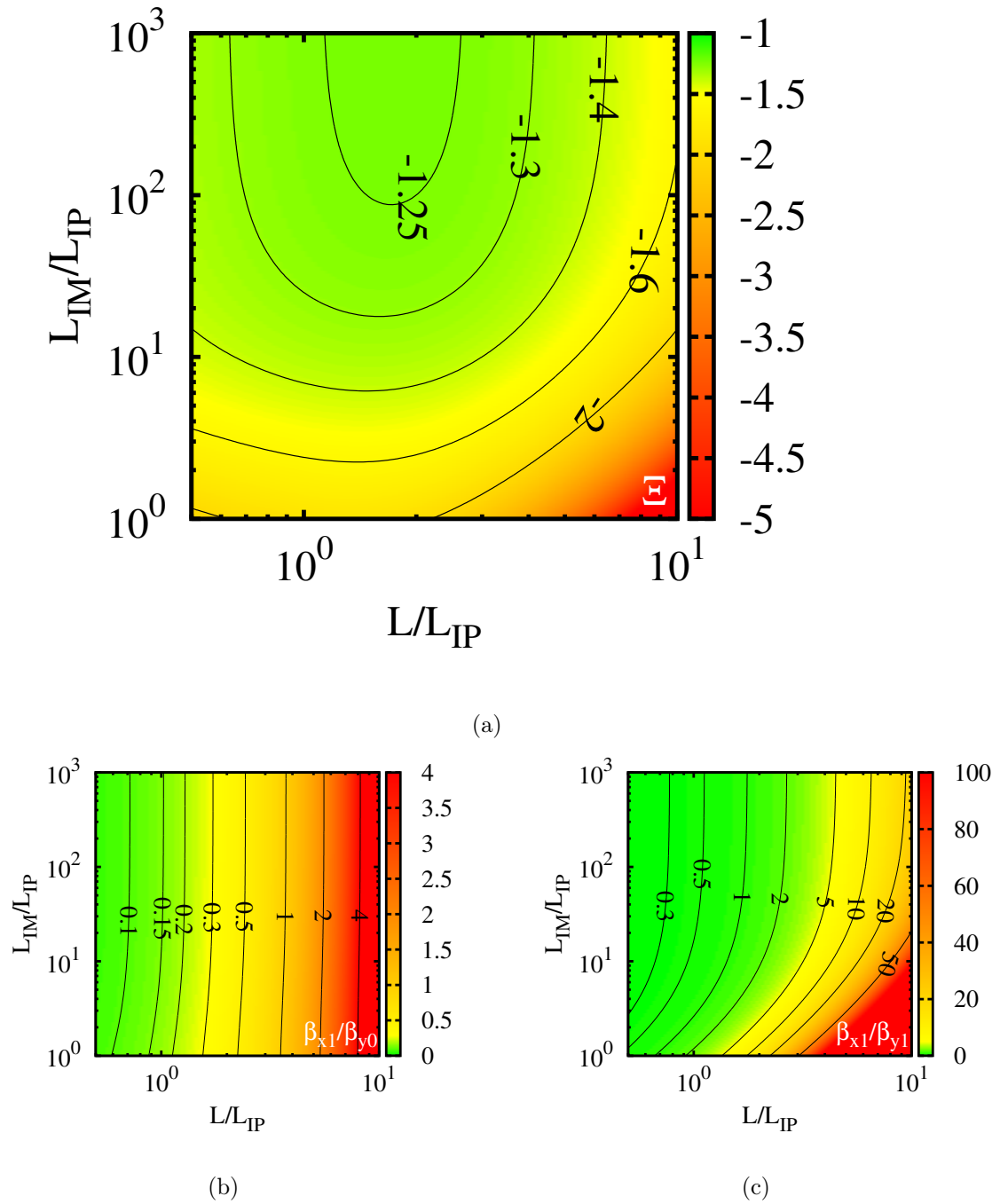

Figure 4.4 – CLIC 500GeV (4.3a) $\Xi(\beta_x^*/\beta_y^*, r, r_{im})$, (4.4b) β_{x1}/β_{y0} , (4.4c) β_{x1}/β_{y1}

4.2 The non-interleaved lattice

4.2.1 Introduction

Large chromaticity is generated in linear colliders due to the ratio of long L^* and low- β^* values. Table 4.1 shows the chromaticity in the current three main linear collider projects.

Parameter	Symbol	ILC	CLIC 500 GeV	CLIC 3 TeV
Distance from IP to QD0 [m]	L^*	3.5/4.5	4.3	3.5
Vertical β at the IP [mm]	β_y^*	0.48	0.1	0.07
Energy Spread [10^{-3}]	δ	3	3	3
Vertical Chromaticity	$\xi_y \approx L^*/\beta_y^*$	7300/9400	43000	50000

Table 4.1 – Approximative vertical chromaticity for the three current linear collider projects.

Two methods have been used to cancel the chromatic effect: non-local and local correction. The local and non-local schemes, presented in Section 2.3.1, have been compared for CLIC [30], concluding in easier tuning capabilities for the non-local. It has been mainly attributed to the separation of the horizontal and vertical chromatic correction sections, while in the local, the horizontal and vertical correction sections are interleaved.

This Section introduces an alternative lattice. In the non-interleaved scheme, the idea is to preserve the separation of the vertical and horizontal chromatic corrections while cancelling the geometrical components in the vertical plane at the FD. One of the paired sextupoles is inside a horizontally dispersive region while the other remains outside to cancel geometric contributions.

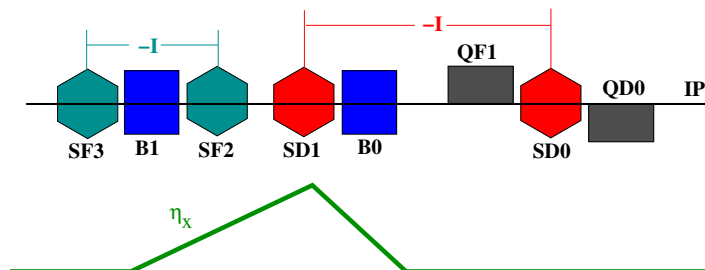

Figure 4.5 – Non-interleaved chromaticity correction.

Horizontal dispersion is generated over a common region and it is cancelled upstream, before the FD. Figure 4.5 shows QD0 preceded by a sextupole SD0, which is matched with a second SD1 by the -I transport map. The same configuration is used to cancel horizontal chromaticity in an upstream section of the lattice using SF sextupoles.

4.2.2 Geometric Terms Cancellation

Previously mentioned chromatic correction schemes use a pair of matched sextupoles to cancel one another geometrical components. It is generally noted as the -I transformation. However, results from [31] show that the -I transformation is one particular solution. When having a pair of sextupoles as in Fig. 4.6 joined by a transport matrix T_{12} , the general solution for

geometrical cancellation is

$$\begin{aligned}
 t_{12} &= 0 \\
 t_{34} &= 0 \\
 t_{11}t_{22} &= 1 \\
 t_{33}t_{44} &= 1 \\
 k_{s1} &= -k_{s2}t_{11} \\
 t_{11} &= \pm t_{33}
 \end{aligned} \tag{4.6}$$

where, t_{ij} are the matrix elements and k_{s1}, k_{s2} are the sextupole gradients. This general solution is used here to give more flexibility to the beta functions in the design.

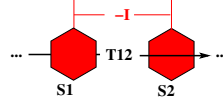

Figure 4.6 – Sextupoles joined by the transport matrix T_{12} .

Figure 4.7 shows the relative phase advances required in the non-interleaved design.

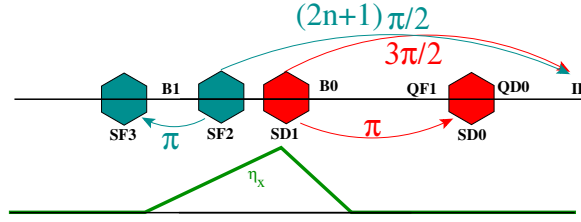

Figure 4.7 – Phase advance in the non-interleaved lattice design.

Those expressions from the linear transport map set restrictions on the optic lattice parameters and tolerances during the lattice design stage. In order to evaluate those tolerances, $\Delta\phi_x, \Delta\phi_y, r_x, r_y$ have been defined as

$$\phi_{x12} + \Delta\phi_x = \pi \tag{4.7}$$

$$\phi_{y12} + \Delta\phi_y = \pi \tag{4.8}$$

$$k_{s1}\beta_{x1}^{3/2} - k_{s2}\beta_{x2}^{3/2} + r_x = 0 \tag{4.9}$$

$$k_{s1}\beta_{y1}^{3/2} - k_{s2}\beta_{y2}^{3/2} + r_y = 0 \tag{4.10}$$

respectively, where $\Delta\phi$ is the phase advance error, r is the residual after subtractions and ϕ, β are the optical parameters in horizontal x and vertical y planes for both sextupoles $S1$ or $S2$.

Factors $\alpha_{x1}\Delta\phi_x, \alpha_{x2}\Delta\phi_x, \alpha_{y1}\Delta\phi_y, \alpha_{y2}\Delta\phi_y \ll 1$, with α the optic parameter, are conditions to achieve geometrical terms cancellation. The FD requires phase advances finely matched because α and β are high, and the residuals r_x, r_y should be close to zero in order to cancel the second order map components in both planes at the same time. The β_y/β_x ratio can be chosen to match sextupole strengths.

4.2.3 The Lattice

Using the CLIC 500 GeV parameters listed in Table 4.2, new lattices were designed in MAD-X [32] following the previous considerations and those in [33]. Figure 4.8 is an example.

Phase advances have been matched to 10^{-6} precision due to high α values in the FD. MAPCLASS2 [34, 35, 36, 37] gives vertical beam size of 1.9nm and horizontal beam size of 186nm to the first order.

Parameter, Symbol, [Units]	Value
Maximum energy/beam, E , [TeV]	0.25
Distance from IP to first quad, L^* , [m]	4.3
Nominal core beam size at IP, σ^* , x/y [nm]	202/2.3
Nominal beta-function at IP, β_x^*, β_y^* , [mm]	8/0.1

Table 4.2 – CLIC 500 GeV parameters used for the non-interleaved lattice design.

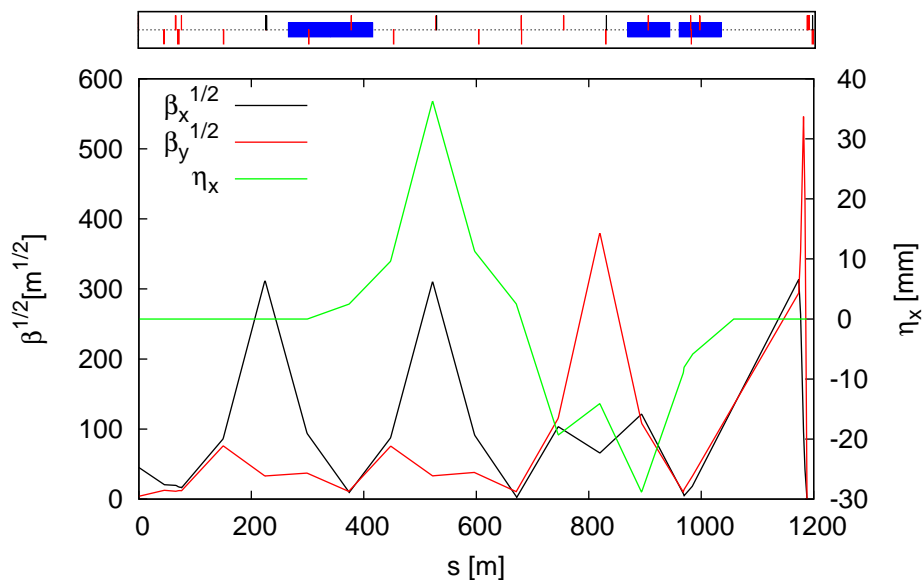

Figure 4.8 – Non-interleaved lattice design for CLIC 500 GeV. Dipoles in blue, horizontally focusing quadrupoles in red and above the axis, vertically focusing quadrupoles in red and below the axis, and sextupoles in black.

However, Fig. 4.9 shows that the horizontal beam size increases slightly to second order and by more than an order of magnitude when third order components in the map are considered.

The reason to this beam size growth is the second order dispersion (T_{166}) in the sextupole inside the FD, see Fig. 4.10. As opposed to the local chromaticity method where T_{166} is cancelled only at the IP by matching the sextupoles and dispersion function, here, the second order dispersion generates higher order components due to the sextupole inside the FD used for geometrical cancellation. This is not present in the non-local method because there is no sextupole in the FD.

Two possible solutions are foreseen at the moment : cancel the map components T_{166} and T_{266} before the FD, or alternatively tolerate some dispersion in the FD to cancel the second order map and making it similar to the local method.

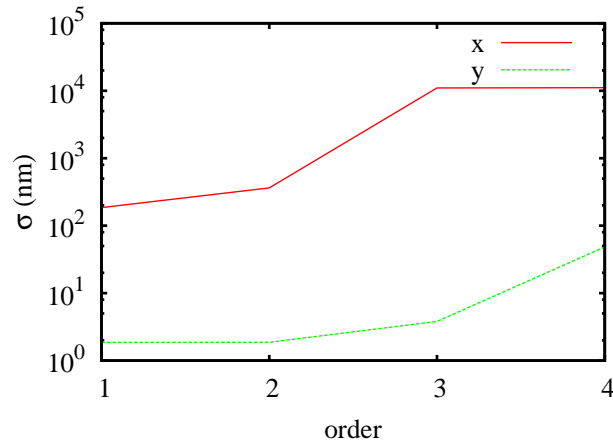

Figure 4.9 – Beam size at the IP of the CLIC 500 GeV non-interleaved design as a function of transfer map order obtained with MAD-X PTC.

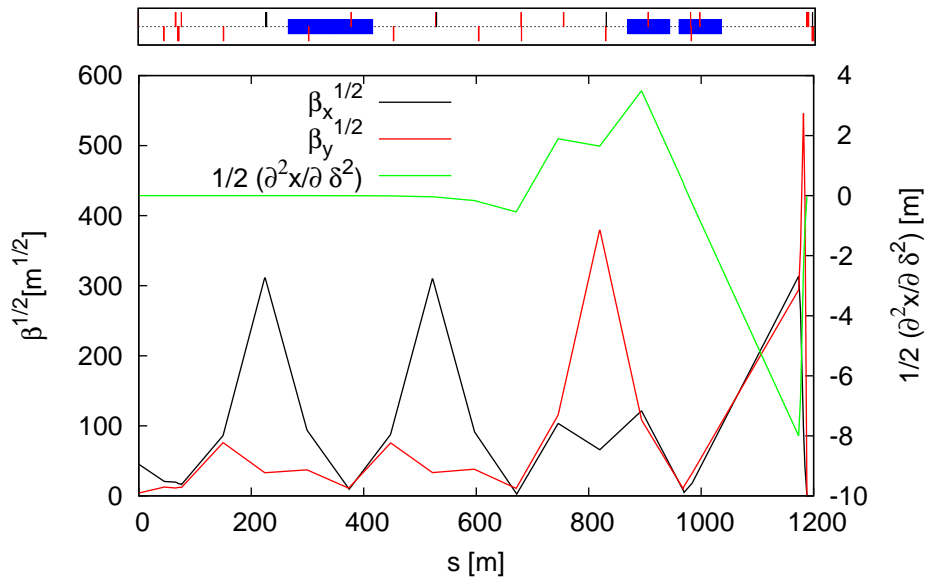

Figure 4.10 – CLIC 500 GeV non-interleaved lattice. The second order dispersion from the T_{166} map component is not zero at the sextupole in the FD.

4.2.4 Conclusion

The non-interleaved lattice proposal has been conceived as an alternative to the local and non-local chromaticity correction methods. The added horizontal and vertical chromaticity has been minimized by using a distance from QD0 to QF1 approximately one and two times the distance between QD0 and the IP. Also, a general geometrical cancellation has been used to

give more flexibility to the linear lattice design, however the large beta functions close to the FD impose high precision in the phase advance between sextupole elements.

The non-interleaved design for CLIC 500 GeV has been diagnosed using MAD-X and MAPCLASS2, concluding that the second order dispersion must be cancelled before the FD because of the high gradient sextupole before QD0 used to cancel geometrical components only.

Two solutions are foreseen : the cancellation of the second order dispersion and its derivative before the FD, or alternatively generate dispersion in the FD to cancel the residual second and third order components making it similar to the local correction.

Cancellation could be achieved by introducing an additional horizontal focal point upstream with no dispersion and no sextupole, this will increase the amount of total horizontal chromaticity, thereby changing the SF2 and SF3 sextupole strengths without changing the quads in the dispersive region, and enabling perhaps a better cancellation of T166 generated by the quad and sextupole in the dispersive part.

Chapter 5

Radiation in Bending Magnets

Considering radiation effects is crucial during the design stage of an accelerator, where effects can be evaluated by tracking particles through the lattice or by analytical approximations. However, during the design process this effect is evaluated iteratively after lattice optic parameters are set. In order to include both, radiation and optic parameters, during the design optimization process, radiation in bending magnets is reviewed in this chapter.

The theory developed by Sands in [4] is first presented in order to clarify all terms used in the beam size contribution from the radiation model. The analytical result in [4] is generalized to the case with non-zero alpha at the IP and non-zero dispersion, required during the desing and luminosity optimization process. The closed solution for one dipole and one dipole with a drift is compared with the tracking code PLACET [5] and finally the model validity for the FFS design is analyzed.

5.1 Theoretical approximation

Assuming a lattice that can be described by transport matrices in the form written in the Eq. (5.1), radiation effects can be calculated by the model in [4].

$$\begin{pmatrix} x_2 \\ x'_2 \\ \delta \end{pmatrix} = \begin{pmatrix} C(s_1, s_2) & S(s_1, s_2) & R_{16}(s_1, s_2) \\ C'(s_1, s_2) & S'(s_1, s_2) & R_{26}(s_1, s_2) \\ 0 & 0 & 1 \end{pmatrix} \begin{pmatrix} x_1 \\ x'_1 \\ \delta \end{pmatrix} \quad (5.1)$$

Being $\Delta x_i = R_{16}(s_i, s_p)(-u)/E$, the deviation at the observation point s_p due to the i^{th} photon of energy u radiated at some point s_i , and E the beam energy.

The rhs term in Eq. (5.2) is the sum of Δx_i over the N photons radiated during the time T for the particle to cross the magnet. $N(T)$ describes the probability distribution of photon emission. As we are interested only in the second order moment, the mean $x_0 = \langle \sum_{i=1}^{N(T)} \Delta x_i \rangle$ is subtracted from the sum, obtaining $\langle x \rangle = 0$, $\sigma_{\text{bend}}^2 = \langle x^2 \rangle$, being x the horizontal transverse displacement from the reference orbit of a particle at the observation point.

$$\sum_{i=1}^{N(T)} \Delta x_i - x_0 = x \quad (5.2)$$

The photon emission follows a Poisson distribution as a consequence of the normalized radiation spectrum and photon number spectrum of synchrotron radiation used in [38] (Section 5). For any Poisson-like distribution $\sigma_N^2 = \langle N \rangle$. The beam size contribution due to

radiation has two components of variability: the spread of Δx_i due to the energy emission u and the number of times the emission process occurs N ¹. Calculations are shown in Eqs. (5.3),

$$\begin{aligned}\sigma_{bend}^2 &= \langle x^2 \rangle - \overbrace{\langle x \rangle^2}^0 = \langle x^2 \rangle \\ &= \langle N \rangle \sigma_{\Delta x}^2 + \langle \Delta x \rangle^2 \sigma_N^2 \\ &= \langle N \rangle \langle (\Delta x)^2 \rangle - \overbrace{\langle N \rangle \langle \Delta x \rangle^2} + \overbrace{\langle \Delta x \rangle^2 \langle N \rangle} \\ &= \langle N \rangle \langle (\Delta x)^2 \rangle\end{aligned}\quad (5.3)$$

where the i sub-index has been removed intentionally because the photon number emission is extracted from a continuous function of u , the photon energy and either T or s/c , where c is the speed of light.

The rate of emission of photons is calculated as in Eq. (5.4) where $K_{5/3}$ is the modified Bessel function, $u_c = \frac{3}{2} \frac{\hbar c \gamma^3}{\rho}$ called the critical energy which depends on the relativistic factor γ , the reduced Planck constant \hbar and the particle trajectory curvature ρ , and $P_\gamma = \frac{2cr_e m c^2}{3\rho^2} \gamma^4$ is the instantaneous radiated power where r_e is the classical electron radius and m is the electron mass.

$$n(u, s) = \frac{P_\gamma}{u_c^2} \left[\frac{9\sqrt{3}}{8\pi} \int_{u/u_c}^{\infty} K_{5/3}(\xi) d\xi \right] \quad (5.4)$$

Using $\Delta x(s) = (-u/E)R_{16}(s, s_p)$ the second moment is calculated by integration over the entire space and energies.

$$\sigma_{bend}^2 = \int_0^T \int_0^\infty [\Delta x(u, s)]^2 n(u, s) du dT \quad (5.5)$$

$$= \frac{1}{c} \int_0^{s_p} \int_0^\infty \left[\frac{-u}{E} R_{16}(s, s_p) \right]^2 n(u, s) du ds \quad (5.6)$$

Finally,

$$\sigma_{bend}^2 = C_2 \int_0^{s_p} \frac{E^5}{\rho^3} R_{16}(s, s_p)^2 ds \quad (5.7)$$

where $C_2 = \frac{55}{24\sqrt{3}} \frac{r_e \hbar c}{(mc^2)^6} = 4.13 \times 10^{-11} \text{ m}^2 \text{ GeV}^{-5}$ is a constant coming from the emission rate integration already derived by Sands.

5.1.1 Generalization of the optimization process

During the optimization process it is convenient to rewrite R_{16} using the off-momentum function η , lattice parameters and Eq. (5.1). Measuring from the reference orbit, the kick propagation from s to s_p can be written in terms of the general transport matrix, giving

$$\Delta x(s)_{total} = \frac{-u}{E} \eta(s_p) = \frac{-u}{E} [C(s, s_p)\eta(s) + S(s, s_p)\eta'(s) + R_{16}(s, s_p)] \quad (5.8)$$

$$\eta(s_p) = \sqrt{\frac{\beta_{s_p}}{\beta_s}} [\eta_s \cos \Delta\phi_{s, s_p} + (\alpha_s \eta_s + \beta_s \eta'_s) \sin \Delta\phi_{s, s_p}] + R_{16}(s, s_p) \quad (5.9)$$

where α, β and ϕ are the optics parameters and the subscripts indicate the evaluation point. The equations derived by Sands in [4] assume $\alpha_{s_p} = 0, \eta_{s_p} = 0$ and $\eta'_{s_p} = 0$, which are not valid

1. Using statistics notation, $\sigma_x = V(x)$ and $\langle x \rangle = E(x)$, then, a process with two components of variability has a variance expressed as $V(x) = E(V(x|N)) + V(E(x|N))$. The term $\langle x|N \rangle$ denotes the evaluation of the x variable for a given N

during the lattice optimization process or when the waist shift is used to get more luminosity in ILC and CLIC [26].

From Eq. (5.7) and (5.9) the contribution to beam size due to radiation now can be calculated as:

$$\sigma_{bend}^2 = C_2 \int_0^{s_p} \frac{E_s^5}{\rho_s^3} \left\{ \sqrt{\frac{\beta_{s_p}}{\beta_s}} [\eta_s \cos \Delta\phi_{s,s_p} + (\alpha_s \eta_s + \beta_s \eta'_s) \sin \Delta\phi_{s,s_p}] - \eta_{s_p} \right\}^2 ds \quad (5.10)$$

Eq. (5.10) was included in MapClass2 in order to be used during lattice design and luminosity optimization. It is also worth noting that $\eta_{s_p} = 0$ agrees with the result obtained by Sands in the ideal case with zero dispersion at the IP. This generalized expression I obtained is solved for the simple case of one bending magnet and compared with tracking results.

5.1.2 One dipole and one dipole with a drift

An analytical closed expression has been derived for two cases: one sector magnet (ρ, L, θ), and a sector magnet plus a drift (L_{drift}). Beam energy loss is negligible compared with beam energy E .

For a sector magnet, $R_{16} = \rho(1 - \cos\theta)$, the radiation effect is calculated as follows

$$\sigma_{bend}^2 = C_2 E^5 \int_0^\theta \frac{1}{\rho^3} [\rho(1 - \cos(\theta - \chi))]^2 \rho d\chi \quad (5.11)$$

$$= C_2 E^5 \left[\frac{1}{4} (6\theta - 8 \sin\theta + \sin(2\theta)) \right] \quad (5.12)$$

$$= C_2 E^5 \left(\frac{\theta^5}{20} - \frac{\theta^7}{168} + \frac{\theta^9}{2880} - \frac{17\theta^{11}}{1330560} + O(\theta^{13}) \right) \quad (5.13)$$

In the case of a drift after the bending magnet and defining $j = \frac{L_{drift}}{\rho} = \frac{L_{drift}}{L} \theta$

$$\sigma_{bend}^2 = C_2 \int_0^\theta E^5 \left[1 - \cos(\theta - \xi) + \frac{L_{drift}}{\rho} \sin(\theta - \xi) \right]^2 d\xi \quad (5.14)$$

$$= \frac{C_2}{4} E^5 [(1 - j^2) \sin(2\theta) - 8 \sin\theta + 4j(1 - \cos\theta)^2 + (6 - 2j^2)\theta] \quad (5.15)$$

$$= C_2 E^5 \left[\frac{j^2 \theta^3}{3} + \frac{j \theta^4}{4} - \frac{(4j^2 - 3)\theta^5}{60} - \frac{j \theta^6}{24} + \frac{(16j^2 - 15)\theta^7}{2520} + \frac{j \theta^8}{320} - \frac{(64j^2 - 63)\theta^9}{181440} - \frac{17j \theta^{10}}{120960} + \frac{(256j^2 - 255)\theta^{11}}{19958400} + \frac{31j \theta^{12}}{7257600} - \frac{(1024j^2 - 1023)\theta^{13}}{3113510400} + O(\theta^{14}) \right] \quad (5.16)$$

Eqs. (5.12) and (5.15) will be used to normalize the results from MAPCLASS2 and PLACET [5] where some care should be taken due to numerical precision.

5.2 Comparison of theory and tracking results

The closed expression in Section 5.1.2 is now compared with the general expression included in MAPCLASS2, Eq. (5.10), and the tracking code PLACET in the case of one dipole and one dipole and a drift. This is shown in Fig. (5.1), normalized to the close expressions in Eqs.

(5.12) and (5.15), where radiation effect in PLACET was obtained by subtracting the squared beam size from two trackings with same input parameters except for radiation ON/OFF.

Figures (5.1) (a) and (b) show the effect of systematic change of θ while keeping ρ and L . Figures (5.1) (c) and (d) show the effect of changing L while keeping ρ and θ . Figures (5.1) (e) and (f) show the effect of changing L_{drift} while keeping the magnet constant. The equivalent magnetic field B is calculated using the magnetic rigidity $B\rho = P/e$ for $E = 1.5$ TeV.

When observing the PLACET results in Fig. 5.1, the left plots show agreement of (80~90)% between the closed expression and the tracking, while the right side shows perfect agreement in almost all cases. The difference is the tracking method used by PLACET.

In PLACET 0.99.01 two different implementations of radiation exist: the first is the ‘default’ and the second one will be called ‘six_dim’. ‘Default’ calculates radiation by segmenting the dipole in a *default* number of shorter pieces with Binomial probability of photon emission when the particle traverses each slide. This is called thin dipole approximation and it is also the default tracking method. On the other side, ‘six_dim’ does not make any sectioning of the dipole, it uses the Poisson probability of photon emission over the entire dipole, as in the theory.

In order to confirm, the authors of PLACET provided several variations of the code where the number of slices was increased, making the Binomial probability to approach the Poisson distribution. In the light of the results presented on this thesis, since PLACET 0.99.02 ‘six_dim’ is the default tracking method.

As expected, the MAPCLASS2 and the closed expression are in good agreement, showing the validity of the generalization in Section 5.1.1. There is a point to highlight in Fig. (5.1) (b). The tracking, theoretical and general calculations are all in good agreement in the range of angles between 10^{-2} and 10^{-5} rad. Below 10^{-5} rad the agreement again decays to (80~90)%. This is related to the average number of photons emitted when traversing the dipole and it is explored in Section 5.3.

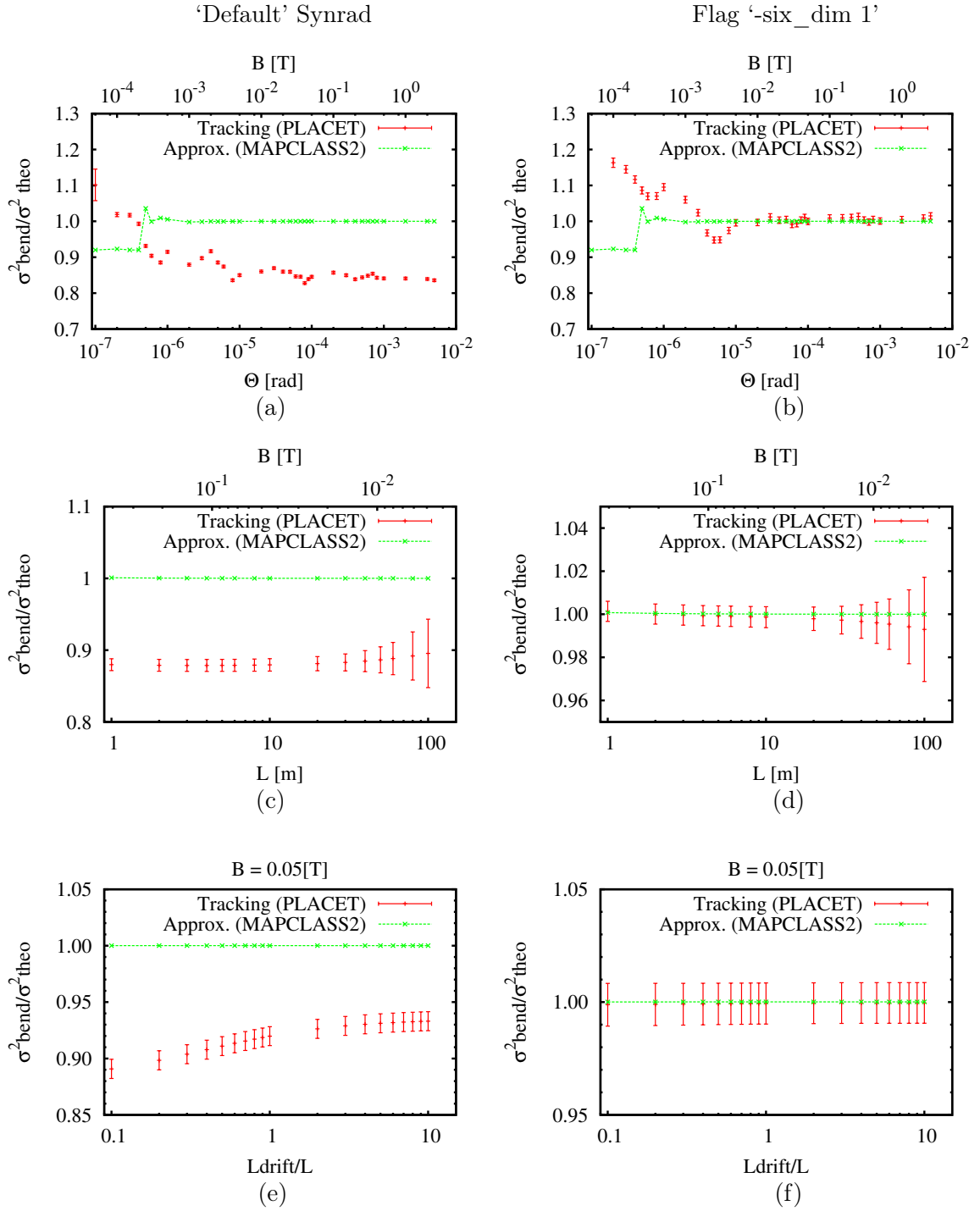

Figure 5.1 – Beam size increase due to radiation normalized to closed expression assuming negligible energy loss. (Left) ‘Default’ radiation option, (Right) ‘Six_dim’ option in PLACET 0.99.01. Plots (a) and (b) correspond to $L = 10$ m for a dipole only. Plots (c) and (d) correspond to $\theta = 10^{-4}$ rad for a dipole only. Plots (e) and (f) correspond to $L = 10$ m and $\theta = 10^{-4}$ rad while varying the drift length. Beam energy is 1500 GeV in all cases.

5.3 Model limitations

The radiation model is valid when the average number of photons radiated per particle $\langle N \rangle$ is enough to characterize the overall effect in position by its second moment, where $\langle N \rangle = C_1 E \theta$ with $C_1 = 20.61 \text{ GeV}^{-1}$.

Although, Section 5.2 explores the variation of θ , this also implies a change in the magnetic field strength B . In this Section the magnetic field is fixed $5 \times 10^{-3} \text{ T}$ and the magnet length L is systematically shortened to reduce the average number of photons emitted by each particle, changing θ because $B\rho$ is fixed for $E = 1500 \text{ GeV}$.

Figure (5.2) shows how the average number of photons emitted decreases with the dipole length L . It is visible also that the region where the average is below one photon is also the starting point when tracking and theory start to differ, reaching $\pm 10\%$ max.

This result is equivalent to the thin dipole approximation mentioned in Section 5.2, where the dipole sectioning makes of each slice a binomial trial of photon emission, approaching the Poisson theoretical distribution for large number of slices.

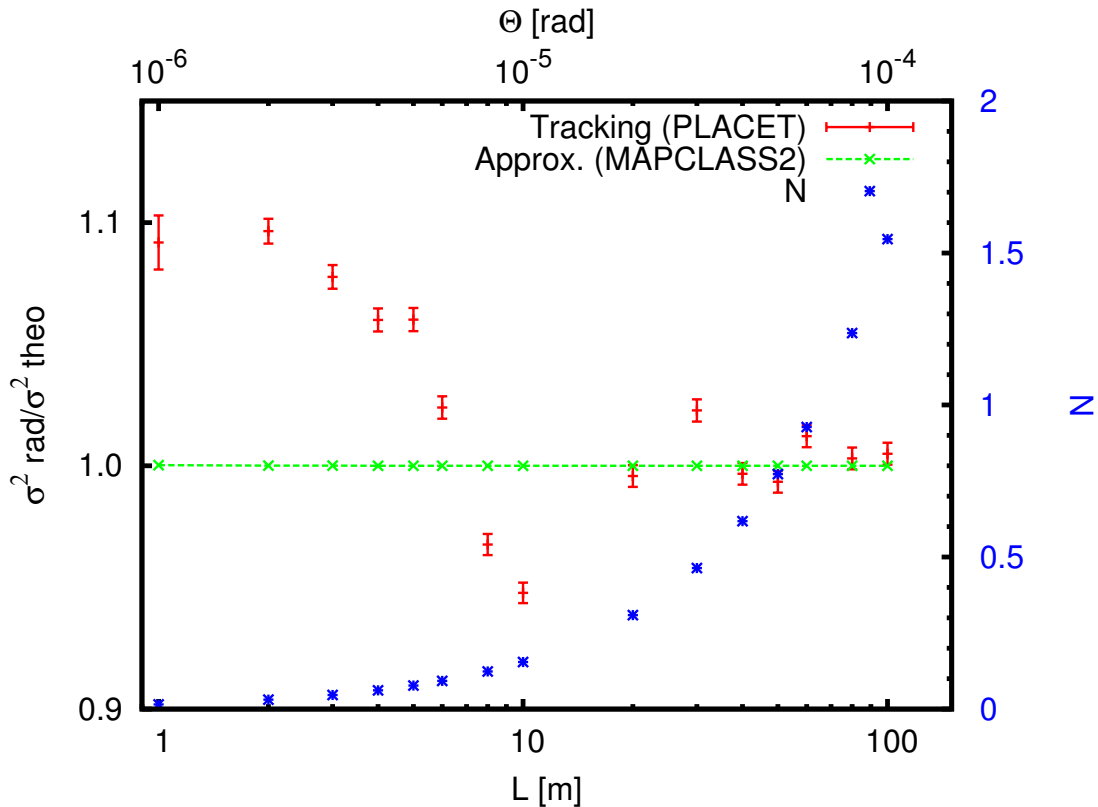

Figure 5.2 – Result from tracking, closed expression with the mean number of photons emitted by particle superimposed. Magnetic field is fixed at $5 \times 10^{-3} \text{ T}$ and $E = 1500 \text{ GeV}$.

5.4 Validity for the FFS

The CLIC FFS design is composed by magnets with bending angles shown in Table 5.1 for 3 TeV and Table 5.2 for 500 GeV. The third column indicates the number of magnets used in each of those sections.

Although the average value of photons emitted per magnet is low, these are grouped in long

sections with common bending angle. Using the conclusions from Sect. 5.3 it will be similar to

$ \theta $ (μrad)	$\langle N \rangle$	Qty.
1.1	0.07	70
3.9	0.24	20
17.2	1.06	10

Table 5.1 – Bending angles in CLIC 3 TeV.

$ \theta $ (μrad)	$\langle N \rangle$	Qty.
8.3	0.08	70
27.5	0.28	20
135.0	1.39	10

Table 5.2 – Bending angles in CLIC 500 GeV.

the thin dipole approximation and the tracking coded should be within $\pm 10\%$ agreement with the theoretical contribution from radiation in bending magnets.

Chapter 6

Oide effect

This part of the document addresses the radiation phenomenon in quadrupoles called Oide effect[3], which sets a limit on the beam size demagnification, specially important in linear colliders because of the strong focusing required in the Final Doublet before the Interaction Point (IP).

First, a brief introduction to the beam size limit (Oide limit) is given, where calculations have been derived to include this radiation phenomenon in the lattice design and optimization software. The Oide effect is evaluated for the CLIC 3 TeV and CLIC 500 GeV parameters, leading to change the length of the first quadrupole before the IP, called QD0. It ends with a proposal to mitigate the impact of the Oide effect by adding correctors before and after the QD0, reducing the beam size.

6.1 Beam size limit

The Oide effect is caused by the interaction of charged particles with the magnetic field from quadrupoles. Radiation in a focusing magnet, schematically represented as QD0 in Fig. (6.1), changes the energy of the particle and modifies the focusing effect. This results in a limit on the minimum beam size specially relevant in the vertical plane.

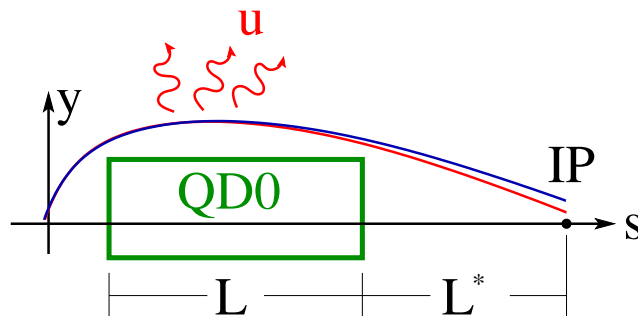

Figure 6.1 – Design particle trajectory in blue and the trajectory of a particle due to radiation in the quadrupole in red.

The beam size growth due to radiation is added quadratically to the linear beam size $\sigma_0^2 = \epsilon\beta$ where β represents the optical beta function and ϵ is the emittance. Therefore, $\sigma^2 = \sigma_0^2 + \sigma_{oide}^2$, where the beam size contribution from the Oide effect is [3],

$$\sigma_{oide}^2 = \frac{110}{3\sqrt{6\pi}} r_e \frac{\lambda_e}{2\pi} \gamma^5 F(\sqrt{k}L, \sqrt{k}L^*) \left(\frac{\epsilon}{\beta^*} \right)^{5/2} \quad (6.1)$$

where

$$F(\sqrt{k}L, \sqrt{k}L^*) = \int_0^{\sqrt{k}L} |\sin \phi + \sqrt{k}L^* \cos \phi|^3 \left[\int_0^\phi (\sin \phi' + \sqrt{k}L^* \cos \phi')^2 d\phi' \right]^2 d\phi \quad (6.2)$$

and λ_e is the Compton wavelength of the electron, r_e is the classical electron radius, γ is the relativistic factor, ϵ is the geometrical beam emittance, β^* is the Twiss parameter at the observation point (in this case, the IP), and k , L and L^* are the quadrupole gradient, the quadrupole length and the distance to the observation point measured from the closest magnet face.

Although the total contribution to beam size depends on the lattice and beam parameters, the minimum achievable beam size is given by [3]

$$\sigma_{y \min} = \left(\frac{7}{5}\right)^{\frac{1}{2}} \left[\frac{275}{3\sqrt{6}\pi} r_e \frac{\lambda_e}{2\pi} F(\sqrt{K}L, \sqrt{K}L^*) \right]^{\frac{1}{7}} (\epsilon_{Ny})^{\frac{5}{7}} \quad (6.3)$$

where $\epsilon_N = \gamma\epsilon$ is the normalized emittance, showing the independence from beam energy.

The only possibility to reduce the beam size is by changing the value of F , by modifying the magnet parameters, or to minimize the beam emittance. However, using the ILC 500 GeV [1], CLIC 500 GeV and CLIC 3 TeV [2] parameters, it is possible to conclude from columns σ_0 and σ_{oide} in Table (6.1) that the contribution of the Oide effect to beam size is only significant for CLIC 3 TeV.

In addition, columns σ and σ_{min} in Table (6.1) show that both CLIC designs are close to the minimum achievable beam size.

Lattice	ϵ_N (nm)	γ (10^3)	σ_0 (nm)	k (m^{-2})	L (m)	L^* (m)	F	σ_{oide} (nm)	σ (nm)	σ_{min} (nm)
CLIC 3 TeV	20	2935.0	0.70	0.116	2.73	3.5	4.086	0.85	1.10	1.00
CLIC 500 GeV	25	489.2	2.3	0.077	3.35	4.3	4.115	0.08	2.3	1.17
ILC 500 GeV	40	489.2	5.7	0.170	2.20	4.3	9.567	0.04	5.7	1.85

Table 6.1 – Vertical beam size and radiation beam size contribution for three lattices. ϵ_N is the normalized emittance, $\epsilon_N = \gamma\epsilon$.

6.2 Oide Double Integral Solution

In this section the double integral used to calculate F is solved with the goal to increase the computational calculation speed. It was included in MapClass2[34, 35, 36, 37] to be used in lattice design and optimization.

The inner integral over ϕ' can be solved because it has a known primitive.

$$\int_0^\phi (\sin \phi' + \sqrt{k}l^* \cos \phi')^2 d\phi' = \frac{\phi}{2} [(\sqrt{k}l^*)^2 + 1] + \frac{\sin(2\phi)}{4} [(\sqrt{k}l^*)^2 - 1] + \sqrt{k}l^* \sin^2 \phi \quad (6.4)$$

The Eq. (6.2) can now be expressed as one integral.

$$F(\sqrt{k}L, \sqrt{k}L^*) = \int_0^{\sqrt{k}L} |\sin \phi + \sqrt{k}l^* \cos \phi|^3 \left(\frac{\phi}{2} [(\sqrt{k}l^*)^2 + 1] + \frac{\sin(2\phi)}{4} [(\sqrt{k}l^*)^2 - 1] + \sqrt{k}l^* \sin^2 \phi \right)^2 d\phi \quad (6.5)$$

The squared factor in brackets is always positive because all inner terms are real. The term inside the absolute value is also always positive, therefore, the integrand is always positive.

Now, considering the function:

$$|\sin \phi + \sqrt{k}l^* \cos \phi| = \begin{cases} \sin \phi + \sqrt{k}l^* \cos \phi, & \text{if, } \sin \phi + \sqrt{k}l^* \cos \phi \geq 0 \\ -(\sin \phi + \sqrt{k}l^* \cos \phi), & \text{if, } \sin \phi + \sqrt{k}l^* \cos \phi < 0 \end{cases} \quad (6.6)$$

sign changes at every point $\phi_n = \arctan(-\sqrt{k}l^*) \pm n\pi$, $n \geq 1$.

It is possible to split the integration interval i times, being i the number of ϕ_n solutions where $0 < \phi_n < \sqrt{k}L$. On each of those intervals, the absolute value definition can be removed and replaced by the corresponding expression in Eq. (6.6), having only a difference in sign. By defining the primitive \mathcal{F} in an interval where the factor inside the absolute value is positive it is possible to evaluate F as it is shown in Eq. (6.7).

$$F(\sqrt{k}L, \sqrt{k}l^*) = \mathcal{F}|_0^{\phi_1} - \mathcal{F}|_{\phi_1}^{\phi_2} + \mathcal{F}|_{\phi_2}^{\phi_3} - \mathcal{F}|_{\phi_3}^{\phi_4} + \dots \pm \mathcal{F}|_{\phi_i}^{\sqrt{k}L} \quad (6.7)$$

The change of signs in each interval is only given by the absolute value definition, then, it is simpler to add the absolute value of each contribution.

$$F(\sqrt{k}L, \sqrt{k}l^*) = |\mathcal{F}|_0^{\phi_1}| + |\mathcal{F}|_{\phi_1}^{\phi_2}| + |\mathcal{F}|_{\phi_2}^{\phi_3}| + |\mathcal{F}|_{\phi_3}^{\phi_4}| + \dots + |\mathcal{F}|_{\phi_i}^{\sqrt{k}L}| \quad (6.8)$$

If we know the primitive \mathcal{F} and we are able to calculate the ϕ_n s in the integration interval, then, it is possible to calculate the factor F without using an approximate integrator. The double integration has been simplified to a primitive evaluation.

The primitive \mathcal{F} exists and it has been calculated using Maxima [39] and Wolfram Alpha Mathematica[40] software, the expression is in Appendix A.

6.3 Mitigating the impact on the beam size

6.3.1 QD0 length

As shown in Sect. 6.1 the Oide beam size contribution depends on a combination of beam and optics parameters. If none of the beam parameters is to be changed then F can be used as a figure of merit of the optics as it is calculated only from k , L and l^* . The target is to reduce it as much as possible. Two energy cases are analyzed in the following: 3 TeV ($l^* = 3.5$ m) and 500 GeV ($l^* = 4.3$ m).

Columns σ_0 , σ_{oide} and F in Table 6.1 show that CLIC 3 TeV and 500 GeV [2, 41] have larger contributions to beam size even having a lower F value than ILC 500 GeV [1].

In order to evaluate the minimum possible F for l^* given, the minimum k required to get the particles focused is when the Twiss function α is zero just at the quadrupole opposite face to the IP.

Figure 6.2a shows the ratio squared between the beam size contribution due to Oide effect and the linear beam size for three cases: when k is the minimum required to get particles focused (to get $\alpha_y = 0$ at QD0 opposite side to the IP), when k is calculated as thin lens ($k = \frac{1}{Ll^*}$), and the current QD0 status. Fig. 6.2b shows the k values for the previous mentioned cases.

The Oide contribution to beam size is of the same order of the linear beam size. It might be possible to reduce it by doubling the current quad length and using a lower k between the minimum required for the focusing and the thin lens approximation. This also points to increasing the lattice length as this change reduces the tolerance to variations of α at the quadrupole input.

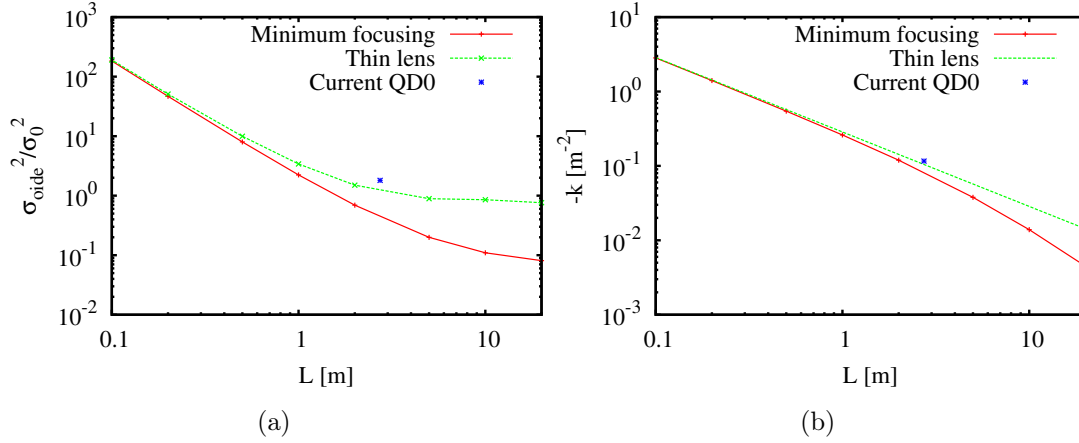

Figure 6.2 – Oide effect beam size contribution for CLIC 3 TeV design parameters. (a) σ_{oide}^2 normalized to designed linear beam size as a function of quad length for the minimum focusing k (when $\alpha_y = 0$ at the quadrupole opposite side to the IP), for k calculated as thin lens ($k = \frac{1}{L^*}$) and the current QD0. (b) k in the three previous cases for comparison.

Quad lengths larger than 10 m do not lead to further improvements with the current parameters.

Figure 6.3 is the corresponding to Fig. 6.2 for the 500 GeV case. The current design contributes less than 4% of the total beam size, concluding that the current QD0 length with the CLIC 500 GeV parameters does not need adjustment.

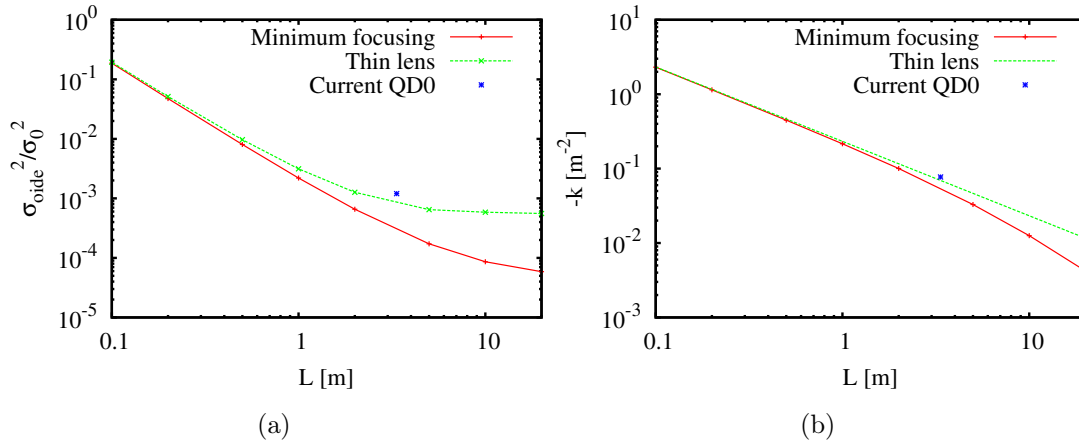

Figure 6.3 – Oide effect beam size contribution for CLIC 500 GeV design parameters. (a) σ_{oide}^2 normalized to designed linear beam size as a function of quad length for the minimum focusing k (when $\alpha_y = 0$ at the quadrupole opposite side to the IP), for k calculated as thin lens ($k = \frac{1}{L^*}$) and the current QD0. (b) k in the three previous cases for comparison.

6.3.2 Correctors

Δy due to radiation

Particle tracking from the input of QD0 to the IP for CLIC 3 TeV with and without radiation, using PLACET [5], allows one to compute the effects of radiation on the six dimensional phase space. Figure 6.4 shows the current transverse distribution of particles at the IP. To

compensate the adverse effects a compensation system would ideally remove the position change due to radiation $\Delta y = y_{\text{rad}} - y_0$.

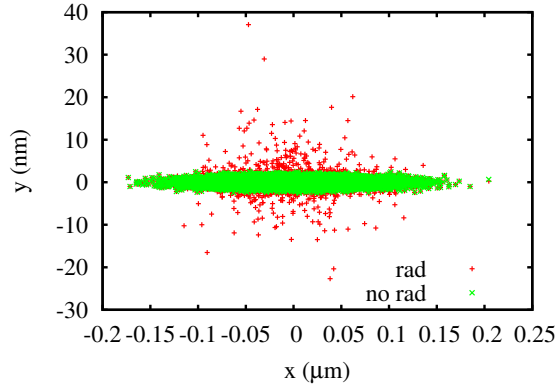

Figure 6.4 – CLIC 3 TeV beam at the IP after tracking through QD0 with and without radiation.

Although the average radiation effect is zero, $\langle \Delta y \rangle = 0$ because of the cubic term $(y'_0)^3$ as stated by Oide [3], the correlation between $\Delta y, y'$ is not zero. The correlation expression is shown in Eq. (6.9).

$$\langle \Delta y, y'_0 \rangle = \frac{2}{3} r_e \gamma^3 G(\sqrt{KL}, \sqrt{KL}^*) (y'_0)^3 \quad (6.9)$$

where $G(\sqrt{KL}, \sqrt{KL}^*)$ is given by

$$\int_0^{\sqrt{KL}} (\sin \phi + \sqrt{KL}^* \cos \phi)^2 \int_0^\phi (\sin \phi' + \sqrt{KL}^* \cos \phi')^2 d\phi' d\phi \quad (6.10)$$

Fig. 6.5 shows the comparison between the correlation obtained from tracking and the theoretical evaluation of the previous expression.

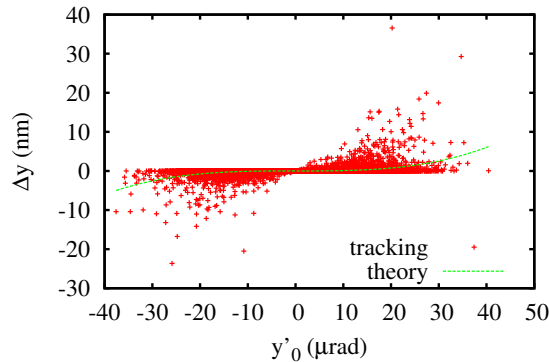

Figure 6.5 – Correlation between the phase space coordinates $\Delta y, y'$ for CLIC 3 TeV from particle tracking and theoretical expression in Eq. (6.9).

This correlation could be removed from the beam size by a set of octupolar correctors to be presented in next Section.

Correctors

A pair of correctors, placed as in Fig. 6.6, is added to the strong focusing in order to mitigate the radiation effect. Particles that did not radiate along QD0 receive kicks in C1 and C0

cancelling one another. However, the C1 and C0 kicks do not cancel for particles that did radiate, this difference is used to correct only the particles trajectory change due to radiation.

The procedure consists in scanning the best position and multipole gradient (s, k_i) for C0, and then set C1 at QD0 input to cancel the effect of C0. If two points with same β_y/β_x ratio are chosen, then the mutual cancellation of C1 and C0 correctors is limited only by the phase advance between them [31] and angle dispersion in the general case. Figure 6.7 shows the horizontal and vertical β functions for CLIC 3 TeV in FD region, and their ratio.

The equal β_y/β_x ratio for C0 and C1 condition is difficult to fulfill because C0 should be too close to the IP. In addition, it will lead to correctors running at very high strengths perturbing the beam.

A second approach is to minimize the phase advance between correctors. Therefore they will be located on both faces of QD0. This has the advantage of correctors running at lower strengths thanks to large β functions.

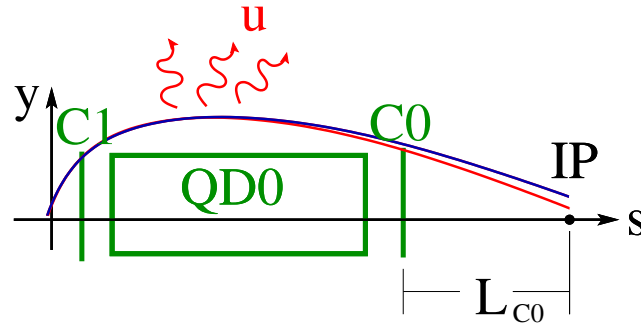

Figure 6.6 – For the nominal trajectory in blue, the kick in C1 must cancel the kick in C0. For all particles that radiate in red, the difference in kicks should cancel Δy .

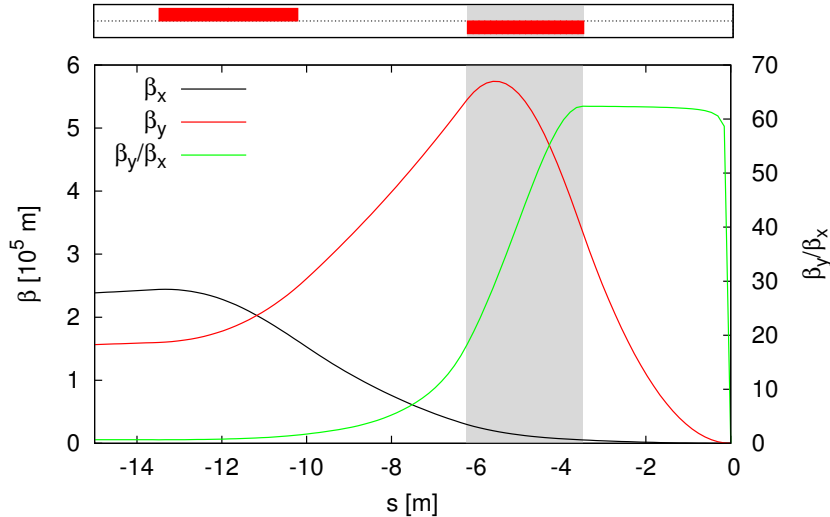

Figure 6.7 – β functions and β_y/β_x ratio for CLIC 3 TeV FD, QF1 and QD0 in red on top. The dark area is occupied by QD0 and the IP is at $s = 0$.

Two octupoles (OD0,OD1) were tried as correctors (C0,C1) to subtract the cubic fit. A CLIC 3 TeV nominal beam with no energy spread is generated at the IP and tracked back to the entrance of the C1 without radiation with both correctors off. This beam is used to study the Oide effect mitigation in QD0 using correctors by tracking to the IP with radiation.

The best result obtained with the octupole correctors is a vertical beam size reduction by

$(-4.3 \pm 0.2)\%$ using OD0 only. Table 6.2 shows the result of luminosity changes less than 10% for the case with no radiation in QD0, with radiation, with one corrector and with the two correctors obtained with Guinea Pig ++ [42].

	OD1		OD0		σ_x [nm]	σ_y [nm]	L_{tot} [$10^{34} \text{ cm}^{-2} \cdot \text{s}^{-1}$]	L_{peak}
	L [m]	k_3 [m^{-4}]	L [m]	k_3 [m^{-4}]				
NO RAD	0.01	0	0.01	0	47.45	0.69	7.7	2.9
RAD	0.01	0	0.01	0	47.45	1.18	7.5	2.7
RAD	0.01	0	0.01	-3900	47.45	1.13	7.4	2.7
RAD	0.01	1502	0.01	-3900	47.45	1.17	7.1	2.7

Table 6.2 – Effect of octupolar correctors on the beam size, total luminosity and peak luminosity.

The Oide effect contribution to vertical beam size affects very little the luminosity. The single corrector option., OD0, does not show any improvement in peak luminosities. However, the case of two correctors OD1 and OD0 shows a drop in the total luminosity. This has been attributed to the limited cancellation between correctors due to different β_y/β_x ratio and phase advance.

The possibility of slicing QD0 in two or three sections and mitigate the radiation effect with a pair of octupoles on each/any slice could be studied.

6.3.3 Conclusions

Radiation in the final quad sets a limit on the vertical beamsizes, this is called Oide effect. Only for CLIC 3 TeV this limit is significant, therefore two possibilities have been explored to mitigate its contribution to beam size: double the length and reduce the QD0 gradient, or the integration of a pair of octupoles before and after QD0.

The best result with octupoles demonstrated vertical beam size reduction of $(4.3 \pm 0.2)\%$, with little or negative impact on luminosity. The correction scheme is currently limited by the phase advance and β_y/β_x ratio between correctors. It may be possible to improve its performance by slicing QD0.

Part III

BPMs at the ATF2 Interaction Point (IPBPMs)

Chapter 7

Relevance of ATF/ATF2

7.1 Facility purpose

The main objective of the Accelerator Test Facility (ATF) built at the High Energy Accelerator Research Organization (KEK) in Tsukuba, Japan, is to serve as R&D platform for the requirements of linear accelerators, in particular ILC. ATF obtained the record of minimum vertical beam emittance [43, 44], see Table 7.1, leading to the next step, the vertical beam size reduction at the IP.

The Final Focus Test Beam (FFTB) [45], at the Stanford Linear Accelerator Center (SLAC) in the U.S.A., explored the beam size reduction using the non-local chromaticity correction scheme. It operated since 1994 to 1997 with a final result of 70nm in the vertical plane. The nominal 40 nm was not achieved and the difference was attributed to beam jitter and tuning limitations [46].

The beam size reduction using the local chromaticity correction is explored by an extension of the original design, called ATF2 [47, 48], which involves an ILC-like FFS lattice scaled down to 100 m with two goals: (**goal 1**) achieve 37 nm of vertical beam size at the IP and (**goal 2**) the stabilization of the IP beam position at the level of few nanometres.

The CLIC, ILC and ATF2 main parameters are shown in Table 7.1, where the vertical chromaticity ξ_y is similar for ATF2 and ILC designs. The ILC and ATF2 relative increase in beam size is a factor 10, calculated from L^* , β^* and σ_δ , if chromaticity is not corrected.

Parameter	Symbol	Units	CLIC 3 TeV	CLIC 500 GeV	ILC	ATF2
Beam Energy per beam	E	GeV	3000	250	250	1.3
Energy Spread (e^+/e^-)	σ_δ	%	0.3	0.3	0.07/0.12	0.06~0.08
Final quad to IP distance	L^*	m	3.5	4.3	3.5/4.5†	1.0
Horizontal β function at the IP	β_x^*	mm	6.9	9	11	4
Vertical β function at the IP	β_y^*	mm	0.07	0.2	0.48	0.1
Normalized horizontal emittance	ϵ_{xN}^*	μm	660	2400	10	2.8
Normalized vertical emittance	ϵ_{yN}^*	nm	20	25	35	31
Horizontal beam size	σ_x^*	nm	45	200	5.9	37
Vertical beam size	σ_y^*	nm	0.9	2.3	5.9	37
Natural vertical chromaticity	ξ_y		50000	43000	7300/9400†	10000

Table 7.1 – Design parameters of ILC and ATF2 Final Focus. †The ILC lattice has two detector options: SiD and ILD.

When compared with the current linear accelerator projects, ATF2 will not be as sensitive to time variations due to ground motion and wakefields, nor to misalignments, because the ATF2 FFS is an order of magnitude shorter than in ILC and because of the larger geometric

emittances involved. However the tolerances to magnetic fields, jitter vibration and power supply stability are similar in ATF2 and ILC.

On the other side, ATF2 needs dedicated systems to measure the beam position and beam size at the IP because the focusing effects of beam-beam interactions used in a collider are not applicable.

7.2 Beam line Description

The ATF accelerator facility, shown in Fig. 7.1, is composed of a photocathode giving electrons to a linac which accelerates the particles to 1.3 GeV, a damping ring to reduce the beam vertical and horizontal emittances and an extraction line which provides bunch packets to the Final Focus Section (FFS) where the beam is transported to the nominal IP and dump. The goal is to generate, accelerate and damp a train of 20 bunches with 2×10^{10} particles per bunch and 2.8 ns bunch spacing. A detailed description is available in [47, 49, 50].

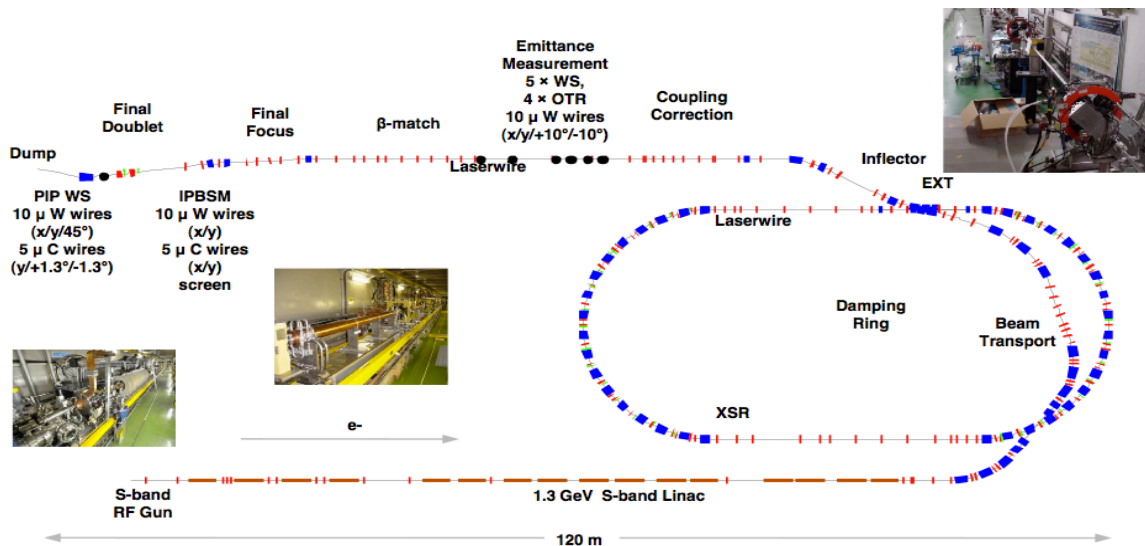

(a) Disposition of the Accelerator Test Facility (ATF), composed by a photocathode, a linac to 1.3 GeV, a damping ring, an extraction line, the Final Focus (FF), and the beam dump.

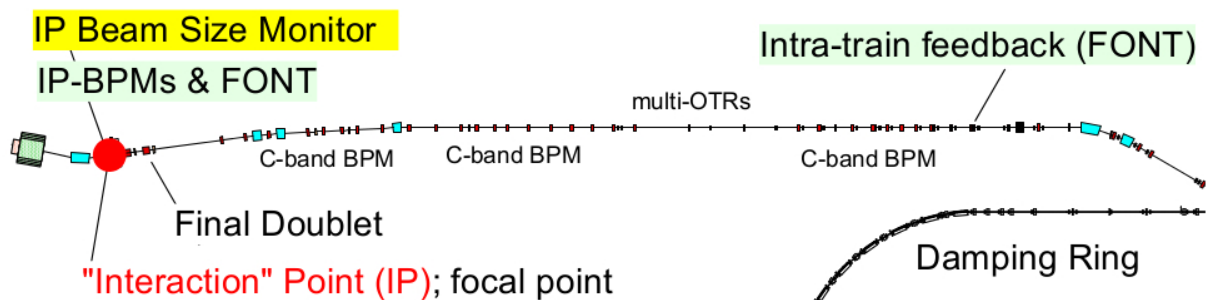

(b) Zoom over the extraction line, and Final Focus Section, highlighting the nominal Interaction Point location (IP). This region is known as ATF2.

Figure 7.1 – Diagrams containing the ATF composition and a zoom on the ATF2 section.

7.2.1 The RF Gun and Linac

The total length of the linac is 80 m divided in: 18 m for the pre-injector section, a 70 m long accelerator section with energy compensation structures and 12 m for the transport line to the damping ring (DR) and a positron test stand. The RF gun with a 1.6 cell S-Band Cs₂Te photocathode generates an electron beam with intensity up to 3.2nC per bunch. The pre-injector contains also an accelerating structure. An accelerating field of 35.2 MeV/m is required to accelerate 20 bunches of 2×10^{10} particles per bunch. The linac is operated at a repetition rate of 25 pps (pulses per second) to allow circulating 5 bunch trains in the Damping ring. Table 7.2 shows the main parameters of the DR.

Beam energy, E_{beam}	1.54 GeV
Bunch population, N	2×10^{10}
Bunches per train, N_b	20
Bunch spacing, Δt_{bunch}	2.8 ns
Energy spread Full Width, σ_δ	<1.0% (90% beam)
Normalized emittance, $\epsilon_{Nx/y}$	< 3×10^{-4} m·rad

Table 7.2 – Basic design parameters of the ATF injector linac.

7.2.2 The Damping Ring

The ring has a length of 138.6 m. It has achieved in 2004 a vertical normalized emittance of 1.5×10^{-8} m·rad, equivalent to 6pm·rad for a bunch intensity of 10^{10} particles. It was achieved by a precise alignment of components and beam control. The structure is a combination of bending magnets and wiggler cells where the value of the horizontal emittance is determined by the structure unit cell. The wigglers reduce the damping time and each bend is placed at the minimum of the dispersion in each periodic structure. The ATF DR consists in 36 of these units cells and the main parameters are in Table 7.3.

Beam energy, E_{beam}	1.54 GeV
Bunch population, N	2×10^{10}
Bunches per train, N_b	20
Bunch spacing, Δt_{bunch}	2.8 ns
Energy spread Full Width, σ_δ	<1.0% (90% beam)
Normalized emittance, $\epsilon_{Nx/y}$	$3 \times 10^{-6}/3 \times 10^{-8}$ m·rad

Table 7.3 – ATF DR main parameters.

7.2.3 The extraction line

In the extraction line the beam is extracted from the DR by means of a first kicker (KICKER1), and then passes off-axis through two quadrupoles centered on the DR reference orbit. Then, the beam passes through three septum magnets which complete the extraction. After the extraction, the beam passes through a dispersion supressor section to reduce fluctuations.

There are two extraction modes: single bunch and multibunch.

In single bunch mode one bunch is extracted approximately every 1/3 s from the damping ring

to the ATF2 line. In multibunch mode a train of up to 20 bunches is extracted from the damping ring. The number of bunches and spacing are set by the damping ring fill up.

7.2.4 The extraction diagnostic section

After the extraction, the diagnostic section is used for measuring the emittance and dispersion, and correcting betatron coupling. This section has been designed to be as close as possible to the ideal skew correction described in [51].

The measured vertical emittance in the diagnostic region downstream shows typically a factor 3 increase with respect to values obtained in the DR and dependence with beam intensity. One of the possibilities of the emittance growth is the non-linearity of the magnetic fields in the extraction region experienced by the beam when passing off-axis. One second possibility is the wakefields induced by the extraction kicker. The correlation with beam intensity is not fully understood; it could be due to the beam position monitors response.

Connecting dispersion and betatron matching plus careful alignment are the keys to mitigate the factor 3 increase in vertical emittance.

7.2.5 The ATF2 lattice

The ATF2 lattice can be subdivided in two sections : the matching section and the FFS. The following section describes the FFS.

The FFS focuses the beam to a small vertical beam size following the telescope design with local chromaticity correction, as in Sect. 2.3.1. The top of Fig. 7.2 shows the lattice elements and the optics functions along the FFS. The Final Doublet (FD), QD0FF and QF1FF, provide the vertical and horizontal focusing, respectively. The horizontal off-momentum function η and the pair of sextupoles in the FD are used to cancel the beam size dependence on energy spread at the IP.

The second pair of sextupoles in the lattice section from 70 to 75 m are used to cancel the geometrical components induced by the sextupoles in the FD. And, additional chromaticity is created upstream QF7 to match the local correction [22], see Section 2.3.1.

Quadrupole displacements are used to steer the beam, while sextupole displacements are used to induce corrective focusing (normal and skew components for horizontal and vertical displacements, respectively). This has an impact on the beam size. The tolerances to misalignments, roll angle and magnet strength errors in the FFS have been initially studied with a target of 2% impact on the beam size, and it has resulted in similar tolerances as in ILC [50]. All quadrupoles and sextupoles are placed on individual movers to allow the beam steering and adjustment of relative alignment in X, Y and Roll angle.

7.2.6 The IP Region

The β functions at the IP, β^* , can be set by changing the matching section quadrupole strengths. Three configurations are normally used : 1BX1BY, 10BX1BY, and 100BX1000BY, where the factor indicates the number of times that the original β^* has been amplified.

The 1BX1BY optics has the original design parameters. Here the angular divergence of the beam is 0.35 mrad vertically and 0.52 mrad horizontally in the IP region.

The 10BX1BY preserves the β_y^* goal while relaxing the tolerance to multipole errors in

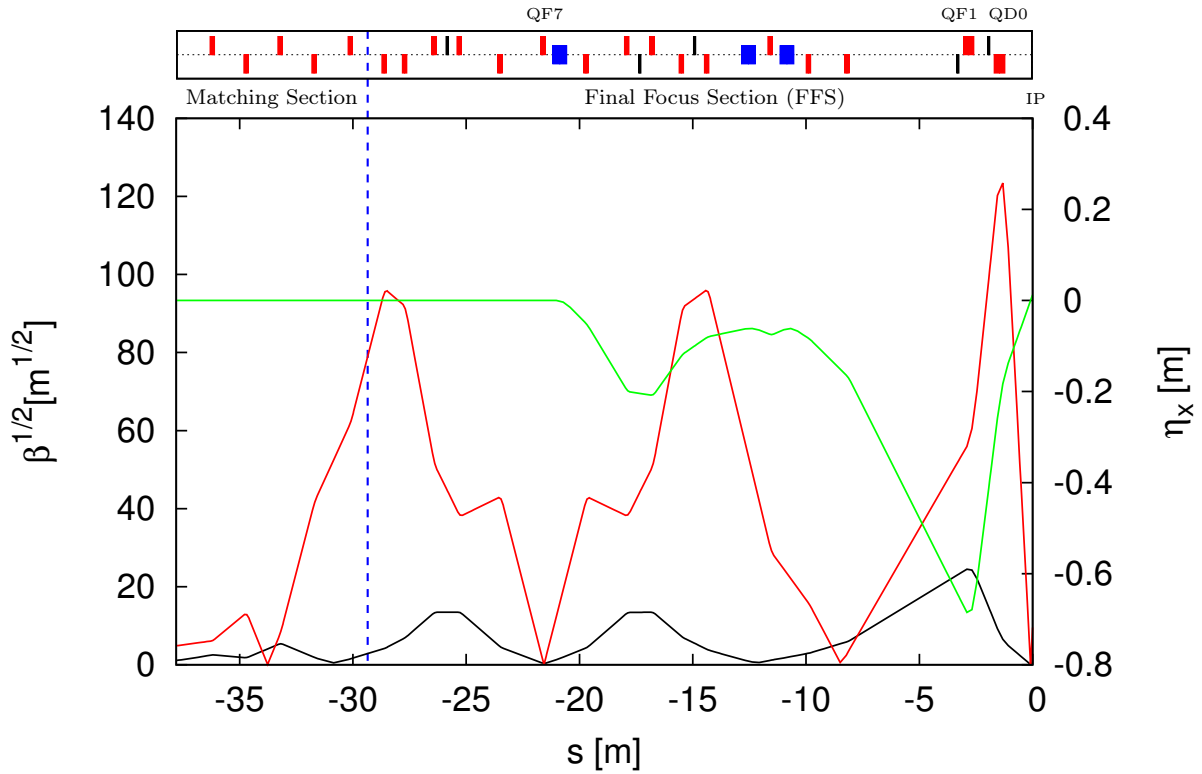

Figure 7.2 – Optical functions in the Final Focus Section at ATF2. On top is the ATF2 lattice: dipoles in blue, quadrupoles in red and sextupoles in black.

magnets by increasing ten times the original β_x^* , making them comparable with those of ILC 500 GeV [52]. This optics is the one shown in Fig. 7.2 and it is currently used in operation.

The 100BX1000BY optics sets a parallel beam through the IP area by enlarging the beam size at the IP. It is principally used to avoid the issues of large angle divergence displayed by the 1BX1BY optics.

Even smaller β_y^* functions have been explored recently at ATF2 aiming to investigate resulting increases in tuning difficulty and beam size measurements limitations [53].

Figure 7.3 shows the beam size in vertical and horizontal planes for several optics combinations in a region of 300 mm around the IP. It also shows clearly how the beam divergence affects the beam size along the IP region.

The QD0 strength sets the vertical beam waist location with a small impact on the horizontal beam waist location, and viceversa for the QF1. The two are set to put the beam waist to its the nominal location at $s = 0$. However, one or a combination of the two quadrupole strengths can be used to bring the beam waist to any location upstream or downstream. Moving the beam waist along the section of the IP region displayed in Fig. 7.3 is effectively changing the focal distance by less than -20% to +10%.

QD0 and QF1 horizontal and vertical movers can also be used to steer the beam in the FD region, changing the position and angle through the IP region. Angles can also be steered by moving QF7 horizontally and vertically because of its location near a focal point upstream. See Fig. 7.1b showing the QF7 location and Eq. (2.2) to see that the kick at the input of a telescope lattice affects only the angle at the output.

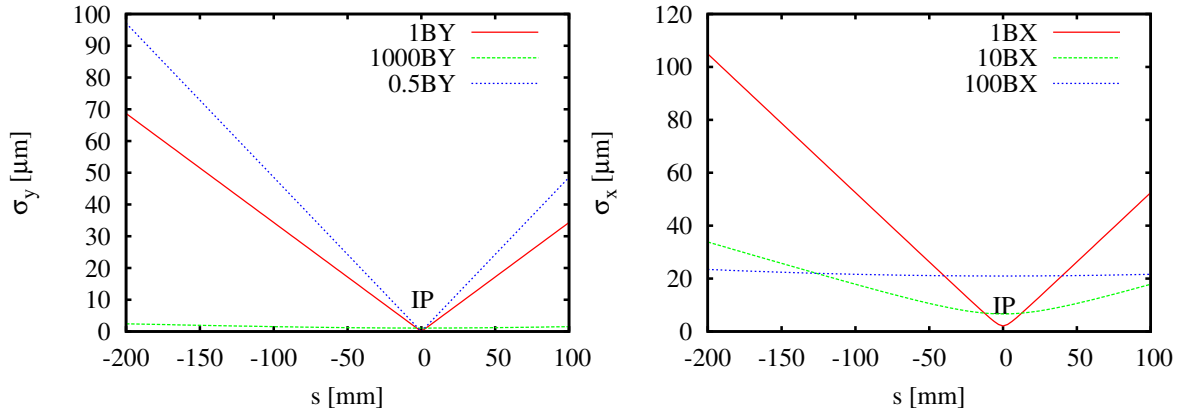

(a) Vertical beam size near the IP.

(b) Horizontal beam size near the IP.

Figure 7.3 – Vertical and horizontal beam sizes for 1BY, 1000BY, and 0.5BY in the vertical plane, and 1BX, 10BX and 100BX in the horizontal plane.

7.3 Beam Size Measurement at the IP

A direct beam size measurement at the ATF2 IP is required because it can not be deduced from beam-beam effects as in a collider.

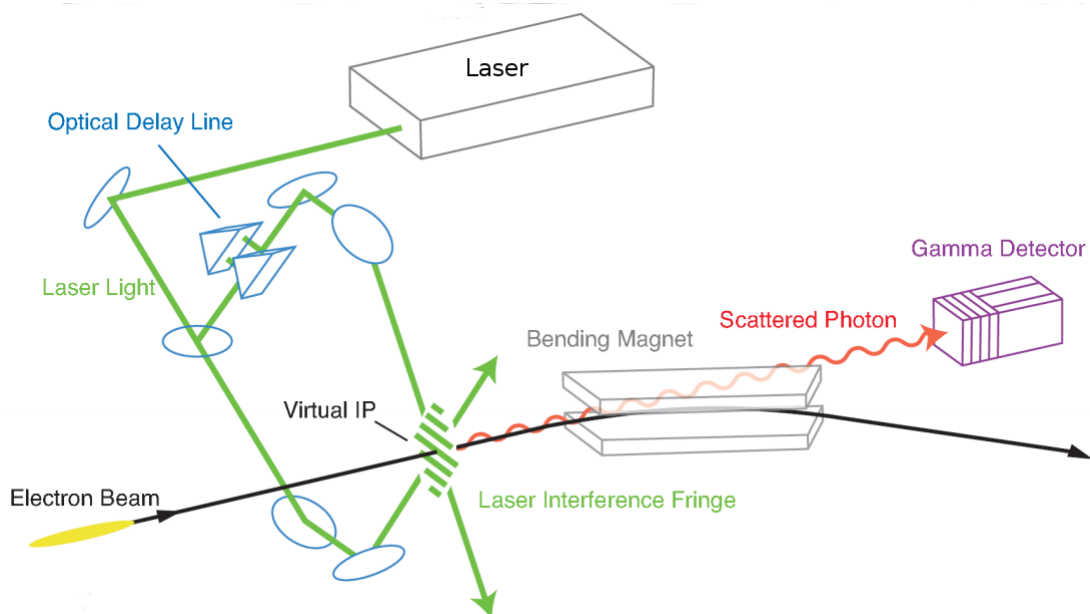

Figure 7.4 – IPBSM schematic design. The particle beams cross the interference pattern generated by a perpendicular laser beam. The number of electron-photon interactions varies with the fringe size and the particle beam size.

The Beam Size Monitor (IPBSM) measures the number of scattered photons from an electron-photon collision between the particle bunch and a perpendicular interference pattern generated by high intensity laser perpendicular to the bunch trajectory [54]. The number of photons is proportional to the photon density at the beam position. Moving the beam or scanning the phase of the laser fringe produces a modulation of gamma flux ray, the amplitude of which depends on beam size [50]. Figure 7.4 shows a schematic design of the IPBSM.

Such a device was previously used at the FFTB line at SLAC [55]. A similar one is now located in the IP region at ATF2 [56].

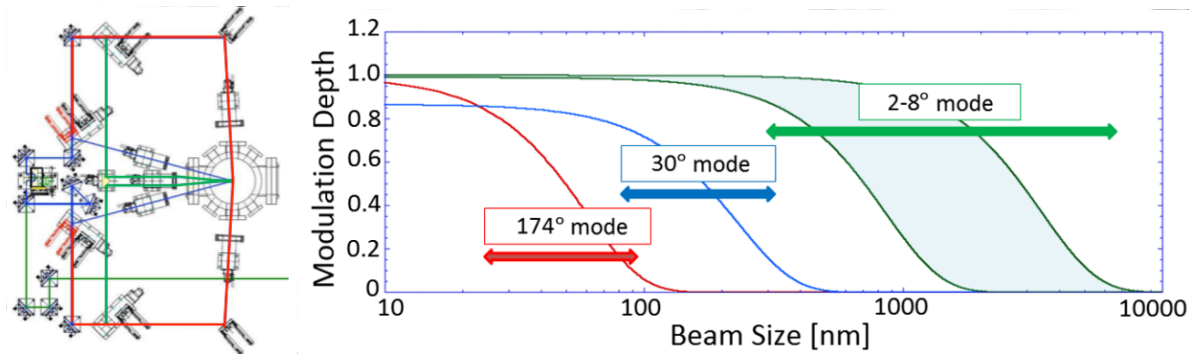

Figure 7.5 – (Right) IPBSM laser path over the optical table perpendicular to the beam propagation. (Left) Beam size resolution for the angle modes : $2 \sim 8^\circ$ in green, 30° in blue and 174° in red.

At ATF2, it is installed on a vertical optical table where the laser incident angle can be adjusted to change the interference fringe pitch allowing measurements of beam sizes from $6 \mu\text{m}$ down to 25 nm . Figure 7.5 shows the laser beam paths along the vertical optical table for three angle modes and the corresponding ranges of possible beam measurements.

Larger beam sizes are measured by a wire scanner installed in the same region. It consists in a wire moved across the beam generating bremsstrahlung gamma rays. The number of photons is proportional to the charge of the slice interacting with the wire at each position setting. Profiles are constructed from the number of photons as a function of wire position [57].

7.4 Beam stabilization

Three regimes are defined for the beam stability: random fluctuations over timescales which are effectively uncorrectable (jitter), fast variations that can be corrected by feedback (FB) systems, and slow or static changes that can be addressed by systematic orbit correction (tuning).

The jitter requirement for goal 1 is beam jitter less than 30% of σ_y , while goal 2 requires jitter less than 5% of σ_y . The measured bunch position jitter upstream of the FD for single bunch extraction mode, i.e. the fluctuations on bunch position before the last strong focusing magnets, is around 10~20% of beam size in the vertical plane and 5~10% on the horizontal plane [58]. Additional jitter could come from the mechanical vibration of the FD.

7.4.1 Tuning

The contribution to beam size due to field errors is considered static or slowly changing. It is possible to reduce their impact by systematic orbit correction using magnetic or mechanical means [47]. Goal 1 jitter requirements can be achieved for single bunch extraction.

7.4.2 Feedback

The fluctuations coming from ground motion, magnet strength variations, changes in the damping ring, energy oscillations are considered fast errors. Also, the bunch to bunch jitter

from multibunch extraction requires active correction.

The feedback system is then the last line of defense to correct the beam trajectory and three schemes are tested in ATF2 using two bunches.

- Upstream FB: Measures the first bunch position in the IP region and uses a set of kickers upstream of the matching section to stabilize the position of the second bunch.
- Feedforward: Measures the first bunch position upstream of the matching section and uses a kicker in the IP region to stabilize the position of a second.
- Local IP FB: Measures the first bunch position in the IP region and uses a kicker in the IP region to stabilize the position of a second.

7.5 Recent achievements and current work

In 2014 vertical beam size about 55 nm was observed at ATF2 [59], and since then smaller beam size are achieved as a regular basis down to 44 nm [60], demonstrating the local chromaticity correction method at charges of about 0.1×10^{10} particles per bunch.

A main identified issue, intensity dependence, is currently explored by the ATF2 collaboration. Nonetheless, at low intensities, the beam size remains above the design 37 nm. Possible contributions are: (1) the increase of the incoming beam emittance along the ATF2 line, (2) systematic errors and resolution limitations on the beam size monitor, (3) beam drift/jitter beyond the tolerable margin and (4) undetected optics mismatch.

Last two issues can be addressed by measuring the beam trajectory in the IP Region after the Final Doublet. In addition, looking forward to **goal 2**, beam position measurement is a requirement for beam stabilization.

The work here described corresponds to the beam position monitors installed in 2013 by LAL in collaboration with Kyungpook National University (KNU), the Feedback in Nanosecond Timescale (FONT) group from Oxford, and the ATF2 staff.

7.6 Position Measurement Requirements

A direct beam position measurement at the ATF2 IP is required because it can not be deduced from beam-beam focusing effects as in a collider [24].

Knowing the beam trajectory with nanometric precision is valuable information for beam tuning and a requirement for feedback. The position measurement system could be used to correct the beam positions used in the reconstruction of the IPBSM modulation pattern, in order to remove the dilution from beam jitter in the beam size reconstruction pulse by pulse.

Therefore, a set of three cavities (IPA, IPB and IPC), two upstream and one downstream of the nominal IP, were installed and are used to measure the beam trajectory in the IP region, thus providing enough information to reconstruct the bunch position and angle at the IP.

Cavities are located at $s = -167.9$ mm, $s = -87.1$ mm and $s = 87.1$ mm, with respect to the nominal IP at $s = 0$. It has been shown in section 7.2.6 the effect of different optics on the beam size along the IP region. As the measured beam jitter upstream is around $10 \sim 20\%$ of beam size, then, the change of optics will have a direct impact on the dynamic range of the position measurement.

Dynamic Range

Table 7.4 shows that beam size only increases by a factor two among the cavities using the 1000BY optics, while Table 7.5 shows a beam one and two thousand times larger than the beam size at the focal point, due to the large divergence in the nominal optics.

From these optics settings the maximum vertical beam size is $58 \mu\text{m}$. The dynamic range required for the cavity is then around 10 to 11 μm using the 20% jitter to beam size ratio.

	IPA	IPB	IP	IPC
s [mm]	-174.2	-87.1	0	87.1
σ_y [$1.086\mu\text{m}$]	2.0	1.3	1	1.3
$\sigma_{y'}$ [0.011mrad]	0.5	0.8	1	0.8

Table 7.4 – Vertical beam size at the cavities positions and the IP with the 1000BY optics.

	IPA	IPB	IP	IPC
s [mm]	-174.2	-87.1	0	87.1
σ_y [34 nm]	1.7×10^3	871	1	871
$\sigma_{y'}$ [0.3 mrad]	$0.6(10^{-3})$	$1.2(10^{-3})$	1	$1.2(10^{-3})$

Table 7.5 – Vertical beam size at the cavities positions and the IP with the 1BY optics.

Resolution and Calibration

The beam stabilization to the nanometer level requires position measurement with nanometric resolution. In addition, due to the low β^* for the nominal 1BX1BY optics, the beam size and therefore the jitter increases rapidly making the 1 nm resolution over the 10 μm dynamic range a challenge. The calibrations must be then valid for measurement over 3 to 4 order of magnitude.

Chapter 8

BPMS System description

In this section I describe the beam position monitor (BPM) system installed at the IP region and the signal analysis method used to test the system.

8.1 The system

The system consists in three cavities inside a vacuum chamber shown in Fig. 8.1a which is fixed to the optical table used for the IPBSM laser and optical instruments. Flanges and viewports on the sides are compatible with the IPBSM operation. Inside the chamber, a system of three cavities (IPA, IPB and IPC) are installed in two separated blocks: one block upstream for IPA and IPB and the other downstream of the IP for IPC.

Each block is placed on top of a piezo-electric displacement system shown in Fig. 8.1b with three degrees of freedom: vertical displacement, horizontal displacement and pitch angle. Position and angle conventions can be seen in Annex B.2.

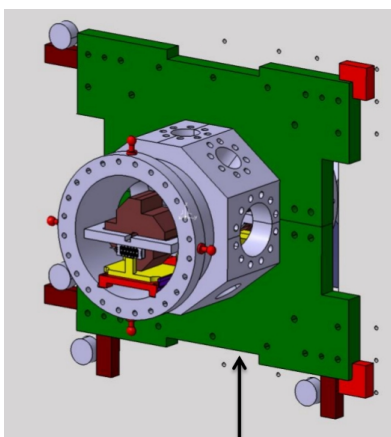

(a) Vacuum chamber design.

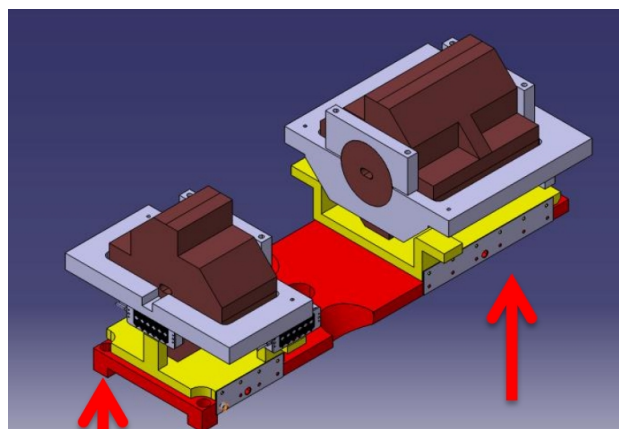

(b) Piezo-electric displacement system and cavities.

This piezo mover system is remotely controlled to align the cavities with the beam, and to do systematic studies of the cavity sensitivity to position change. A set of in-vacuum PT100 thermal gauges are included on each block. The initial checks on the system can be consulted in [61], and the control and readout scheme can be seen in Annex B with alignment results.

8.1.1 The cavities

Cavities for beam position measurement must have good stability since precision depends on mechanical precision. Resolution at thermal noise level of the readout electronics can be achieved by narrowing the dynamic range and using high gain electronics since signal is small near the cavity center. The following is a description of the cavity parameters as presented by Nakamura in [62].

Cavity modes

The cavity consists of a cavity and a waveguide. When the particles pass through the cavity, it resonates in several modes at frequencies given by the cavity dimension and shape [63].

Cylindrical coordinates are used for cylindrical cavities. The electric $E = (E_r, E_\phi, E_z)$ and magnetic field $B = (B_r, B_\phi, B_z)$ are excited in the cavity. For beam position monitoring the transverse mode (TM) $B = (B_r, B_\phi, 0)$ is essential. Three numbers m, n, l which are the mode numbers in r, ϕ, z are used to identify the modes. The TM_{010} is the monopole mode and it is used for charge intensity measurement and downmixing of the signals from the position sensitive cavities. It is shown in Fig. 8.3.

In a similar way, rectangular coordinates are used for rectangular cavities. The electric $E = (E_x, E_y, E_z)$ and magnetic field $B = (B_x, B_y, B_z)$ are excited in the cavity. For beam position monitoring the TM $B = (B_x, B_y, 0)$ is essential. Three numbers m, n, l which are the node numbers in x, y, z are used to identify the modes. The TM_{120} and TM_{210} are the dipole modes and are used for bunch position measurement. The TM_{110} is the monopole mode in rectangular cavities. They are shown in Fig. 8.2.

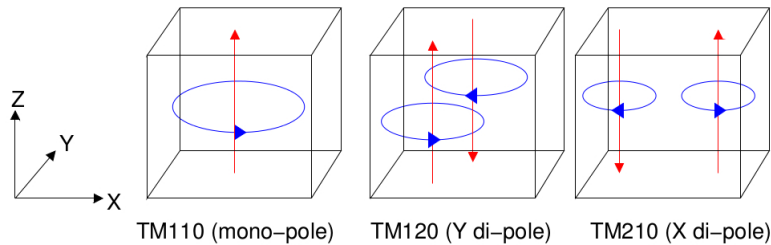

Figure 8.2 – Dipolar and monopolar mode in rectangular cavities.

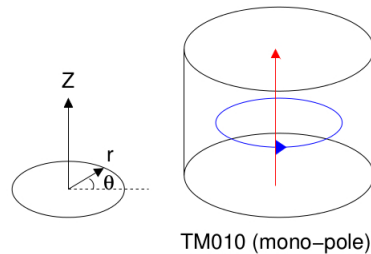

Figure 8.3 – Monopolar mode in cylindrical cavities.

Only the dipole mode is of interest for beam position measurement so it is separated from other modes which are considered noise components. The separation between the vertical and horizontal dipole mode is made by making the cavity rectangular, resulting in different resonant frequencies for each plane.

A set of slots is introduced on the cavity walls to couple only the dipole mode to a waveguide

with a cut-off frequency above the monopole mode. This is made to separate the dipole signal from large noise coming from the monopole component. An antenna picks up the signal in the waveguide and connects it to the output port. The cavity design has then four ports, two ports in antiphase per plane, one on each side. Figure 8.4 shows the cavity transversal plane with the four slots and the coupling to the waveguide and antenna for the horizontal ports.

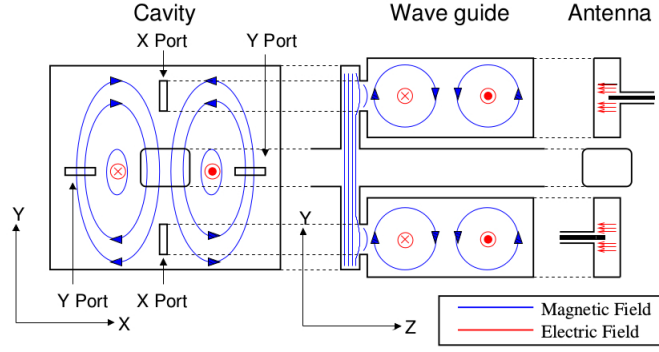

Figure 8.4 – Coupling to the dipole mode of the cavity.

Output signal

Voltage of a resonant mode excited in a cavity by a passing beam, V_{exc} , is expressed as

$$V_{exc} = \frac{\omega}{2} \left(\frac{R}{Q} \right) q \quad (8.1)$$

where ω is the resonant angular frequency of the mode, q is the beam charge, R is the shunt impedance and Q is the quality factor which represents the efficiency of the resonant mode of a cavity. The factor R/Q is

$$\frac{R}{Q} = \frac{|\int E \cdot ds|^2}{\omega U} \quad (8.2)$$

where U is the energy stored in the cavity and $E \cdot ds$ is the longitudinal component of the electric field in the cavity generated by the passing beam. The cavity design for the IP region targets high R/Q (high Q_0), minimizing the energy loss in the cavity walls and maximizing the output power.

The finite bunch length σ_z results in an effective reduction of V_{exc} given by the expression

$$V_{totalexc} = V_{exc} \exp\left(-\frac{\omega^2 \sigma_z^2}{c^2}\right) \quad (8.3)$$

The stored energy of a cavity is $U = V_{totalexc}^2 / (\omega R/Q)$, and the output power is $P_o = \omega U / Q_{ext}$, where Q_{ext} is the quality factor of the external coupling. Detecting the power output, P_o , by an impedance Z gives the output voltage

$$V_{out0} = \sqrt{Z P_o} = \frac{\omega q}{2} \sqrt{\frac{Z}{Q_{ext}} \frac{R}{Q}} \exp\left(-\frac{\omega^2 \sigma_z^2}{2c^2}\right) \quad (8.4)$$

The energy dissipation in the cavity is

$$U = U_0 e^{-\frac{\omega}{Q_L} t} \quad (8.5)$$

where $\frac{1}{Q_L} = \frac{1}{Q_0} + \frac{1}{Q_{ext}}$, and the energy decay time $\tau = Q_L / \omega$. As the signal is proportional to the square root of the power, then the signal decay time is a factor two smaller.

Finally, as the R/Q factor depends on the longitudinal component of the electric field, the integration depends on the TM mode. It has been derived in [62] concluding that in the dipole mode R/Q depends on the square of the bunch transverse position in the case of bunches passing near the center, while the monopole mode R/Q is independent of position. From this, the output voltage in the TM₁₂₀ and TM₂₁₀ is proportional to position, while TM₁₁₀ and TM₀₁₀ are not.

Components orthogonal to position

Additional components are present in the cavity signal output which are orthogonal to bunch position. They have been described in [62] as

$$V = V_{position} + iV_{angle} + iV_{pitch} + iV_{commontail} \quad (8.6)$$

where the imaginary factor i involves a $\pi/2$ phase difference, and the following is a brief description of each component:

- Angle: a cavity of length L gives a position voltage as $V_{position} = Ax\sqrt{L}\sin(\omega t)$. Assuming a beam passing through the cavity center making an angle x' , it can be decomposed as the sum of two position signals with $x = x'L/4$ and phase difference of $\pm L/4c$, affecting the amplitude by $\sin(\omega L/4c)$ and the phase by $\pi/2$. The ratio of angle to position signals for $\omega L/4c \ll 1$ is

$$\frac{|V_{angle}|}{|V_{pos}|} = \frac{\omega L^2 x'}{2\sqrt{2}c x} \quad (8.7)$$

- Pitch: a cavity gives a position voltage as $V_{position} = Aqx\sin(\omega t)$. The beam is decomposed in two points with $q/2$ total charge each, while traversing the cavity with an angle θ . The sum of two position signals with $q/2$ charge each, $x = \sigma_z\theta$ being σ_z the bunch charge, and phase difference of $\pm\sigma_z/c$ will affect the amplitude by $\theta\sigma_z^2/c$ and the phase by $\pi/2$. The ratio of angle to position signals is

$$\frac{|V_{pitch}|}{|V_{pos}|} = \frac{\omega\sigma_z^2\theta}{c x} \quad (8.8)$$

- Commontail: the common-tail [64] comes from the monopole component. At the dipole component frequency it is 2 to 3 orders of magnitude stronger than the dipole component. However, it is attenuated by the coupling to the waveguide. Nakamura [62] shows that the phase advance between the monopole and the dipole signals is $\pi/2$.

The phase difference of these components allows one to remove them from the position signal by phase detection. In addition the cavity design was conceived to reduce the angle signal by making it short to mitigate the effects from the large beam divergence seen in Section 7.2.6.

Cavities at the IP Region

The three cavities (IPA, IPB and IPC) are rectangular and resonate in the TM₂₁₀ and TM₁₂₀ modes, at the C-band frequency of 5.7 and 6.4 GHz, in the horizontal and vertical planes, respectively. They have a design decay time of 19 ns (horizontal) and 17 ns (vertical), and sensitivities to bunch position of 2.2 $\mu\text{V}/\text{nm}/\text{nC}$ (horizontal) and 3.7 $\mu\text{V}/\text{nm}/\text{nC}$ (vertical). Two additional cylindrical cavities with decay time of 29 ns, sensitivity to bunch charge of 3.27 V/nC, one per resonant frequency, are placed downstream of the IP to measure the bunch

charge and to enable downmixing the C-Band frequency signals in the readout (see Section 8.1.2); these are the reference cavities.

The IPA, IPB and IPC sensitivity to orthogonal components are: position to angle ratio of $3.2 \mu\text{m}/\text{mrad}$, position to bunch pitch ratio of $8.6 \mu\text{m}/\text{mrad}$ with $\sigma_z=8$ mm and unknown commontail component.

Previous to the installation, the cavity signals' decay time was measured giving the results shown in Table 8.1. In particular IPC shows a shorter decay time than IPA and IPB. The effect of the large difference between the design and the measured values on resolution is currently under investigation.

Plane	Design	IPA	IPB	IPC
X [ns]	19.41	8.722	8.181	4.925
Y [ns]	17.49	11.11	11.25	6.745

Table 8.1 – Measured decay time for the three cavities before installation.

The reference cavities have been tuned to match the measured resonant dipole frequency from the sensor cavities, showing maximum difference of 3.5 MHz in Table 8.2, and good agreement with the design.

Plane	Design	Reference	IPA	IPB	IPC
X [MHz]	5712	5712	-2	-2.5	+2.5
Y [MHz]	6426	6420	+1	0	-3.5

Table 8.2 – Resonant dipole frequency measurement at KEK before installation.

8.1.2 The processing electronics

Each position measurement cavity has two output ports in antiphase per plane connected to independent processing electronics to downmix the signals, separate them into two orthogonal components called I and Q , and set the gain according to beam charge conditions. A set of remotely-controllable attenuators, variable between 0-70 dB in steps of 10 dB can be used to increase the linear range of electronics at the expense of resolution.

At the moment the reference cavities are not used to downmix the position cavities signals directly to base band. Instead, as explained below, a 714 MHz signal from the DR is used to downmix the three cavity signals to 714 MHz in a first stage and then a second stage downmixes the position cavities to baseband using the reference cavity signal. This allows the installation of the second stage outside the ATF2 line, aiming at studying the signals with different phase detection settings changed by hand in the hardware. An scheme of the electronics is shown in Fig. 8.5. The following is a description of components extracted from [62].

- Combiner: The combiner outputs the difference of the signals. However, the signal from the two cavity ports are in antiphase so the net effect is factor 2 of amplification.
- Variable attenuator: it attenuates the input signal from 0 dB to 70 dB in steps of 10 dB. The purpose is to enlarge the dynamic range at the expense of resolution.
- First stage of down conversion: it downmixes the BPM and reference cavity signals to 714 MHz using an 8×714 MHz (for the vertical plane) and 9×714 MHz (for the horizontal plane) signal from the LOCKED LO module, and amplifies the output by

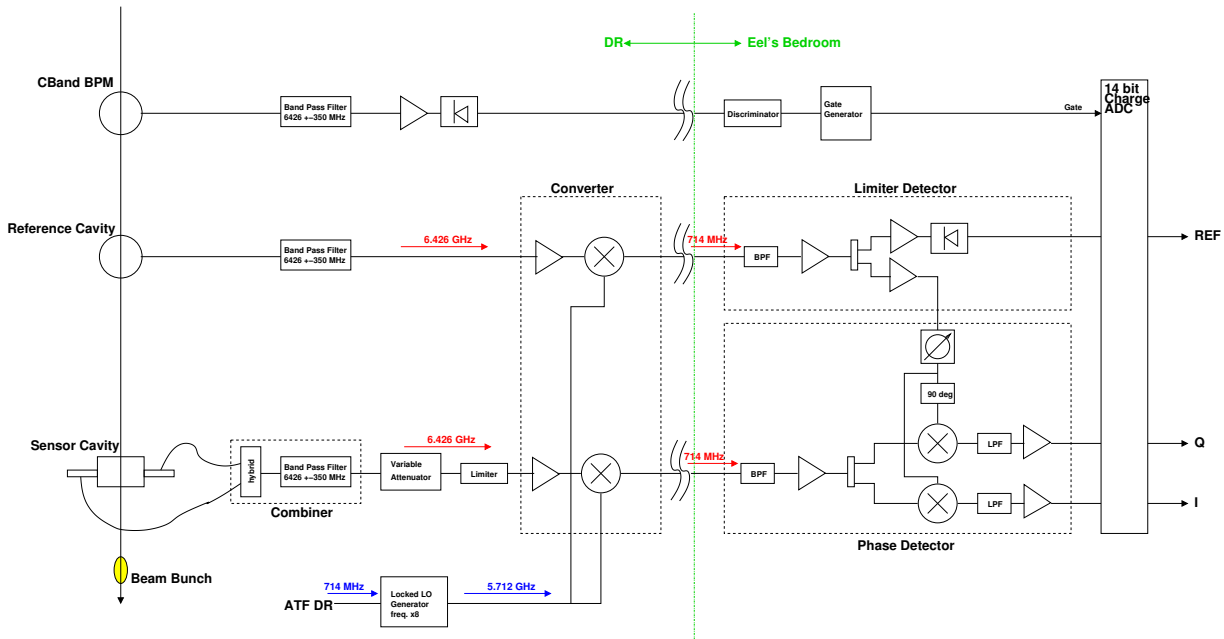

Figure 8.5 – Processing electronics per BPM per plane.

20 dB. It is required to do it as close as possible to the BPMs because of the short decay time.

- LOCKED LO: Multiplies the frequency of the DR 714 MHz by a factor 8 for the vertical plane and 9 for the horizontal plane to perform the first stage of signal downmixing.
- Limiter detector: Set a constant amplitude of the Reference signal at 714 MHz to be used for the downmixing in the second stage. Fig. 8.6 shows a diagram with 4 outputs to be used for downmixing. It also outputs the signal proportional to charge.
- Phase detector: It sets the common phase between the ref cavity signal and the IPBPMs signals by means of a knob. Then, it separates the IPBPMs signals in two set of orthogonal components by downmixing the signals at 0° , 90° , 45° and 135° . The outputs at 0° and 90° are amplified by 25 to 30 dB, and the 45° and 135° outputs by extra 10 dB according to the module used. One of the two orthogonal sets is read out as In-phase (I) and Quadrature-phase (Q).

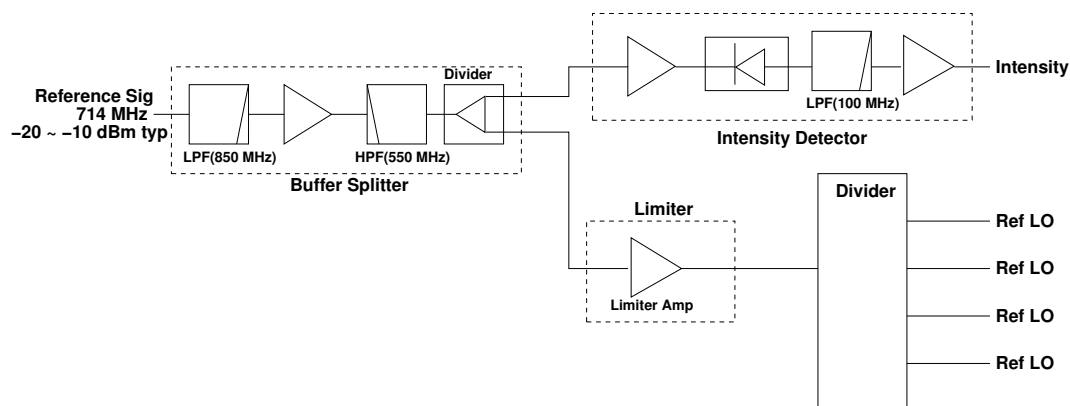

Figure 8.6 – Limiter detector.

At the moment only one Limiter detector is available, therefore, acquisition of only four signals was possible. Priority was given to the study of the three IPBPMs vertical signals. The

horizontal signals were studied only for alignment matters.

The noise floor of the first stage of downmixing has been previously measured to be -95 dBm ($4 \mu\text{V}_{rms}$). It limits the resolution to 2 to 3 nm (horizontal) and 1 to 2 nm (vertical) at 0.5×10^{10} particles per bunch because of sensitivities shown in Sect. 8.1.1.

The gain and attenuation settings are used to achieve the maximum dynamic range within the acquisition system limits described in Sect. 8.1.4. The dynamic range of the electronics is estimated as follows: at 10 dB attenuation, for 0.4×10^{10} particles and $3.7 \mu\text{C}/\text{nm}/\text{nC}$ vertical position sensitivity the signal is $0.75 \mu\text{V}/\text{nm}$. This signal is amplified by a total of 53.7 dB from the first (+20 dB) and second (+43.7 dB) downmixing stages with 10 dB losses estimated from cables and couplers. Using +2.5 V as maximum range of acquisition, the signal dynamic range is $6.9 \mu\text{m}$. This can be directly compared with the dynamic range measurement in Sect. 9.2.

However, the typical input value to the first downmixing stage is of -60 dBm ($223.7 \mu\text{V}_{rms}$). It results in a much tighter dynamic range of 300 nm. The estimated input signal to the first downmixing stage and $6.9 \mu\text{m}$ offset is only -33 dB (5mV_{rms}).

8.1.3 Feedback system

A local beam-based feedback system has been installed at the IP, in order to stabilise the beam position at the IP. This system comprises a stripline kicker, just upstream of the IP chamber, a fast kicker amplifier and digital feedback controller, and can be driven by any of the three IPBPM IQ signals, or a linear combination of the signals from any two BPMs. The system is designed for operation within bunch train of two or more bunches, separated by less than 150-200 ns, where the measurement of the first bunch provides the input to the feedback system, and the correction is applied to subsequent bunches.

8.1.4 The acquisition system

The acquisition system samples the two downmixed orthogonal waveforms per cavity per plane over the decay time. This amounts to 14 simultaneous channels: I and Q waveforms for both x and y for each of the three position measurement cavities plus the charge signal from each of the two reference cavities.

The resolution required to measure 1 nm over the $10 \mu\text{m}$ of dynamic range is at least 14 bits (2^{14} discrete steps). However, several systems have been used during the course of the IPBPM operation.

Initially a set of four Agilent 3000 X-Series oscilloscopes of 8 bits resolution, four channels each, 5V_{rms} dynamic range and up to 4 Gsamples/s was used for IPBPMs commissioning. Also a dedicated acquisition board, FONT5, operated by FONT group to perform the IP feedback was used. It digitised 9 channels synchronized in banks of three, 13 bits resolution, and a maximum sampling of 400 MHz with $\pm 0.5 \text{V}$ dynamic range.

A dedicated acquisition system built around a SIS digitizer has recently been introduced. The resolution is 14-bits, the dynamic range is either 2 or 5 V, and the sampling frequency is configurable with 238 MHz being the typical value. This is an important step towards integration of the IP position measurements into the existing ATF control system because of the gain in dynamic range, higher resolution and assured data availability.

8.2 BPM Analysis Method

The system has been tested with three sets of optics : (1) parallel beam (large beam size at waist and hence approximately constant beam size through the IP region) (2) nominal and (3) low beta.

The longitudinal position of the beam focus was moved closer to the location of IPB, by changing the strength of the FD, to reduce the beam jitter at IPB, allowing operation without additional attenuation and hence maximal sensitivity.

8.2.1 Waveform analysis

The I and Q waveforms are analysed by choosing a single sample point on the signal. In general, the on-peak sample is chosen except in cases where the post analysis shows saturation of the processing electronics. The identification of position and orthogonal components requires a position scan, as explained in Section 8.2.2.

Averaging or integrating the samples may do something to improve the analysis due to the presence of (714 ± 10) MHz band pass filters between the first and second stage of downmixing of the processing electronics as part of an investigation into the reduction of large unwanted static waveform components.

8.2.2 Position scans

While the beam is running the cavity position is systematically changed and the I and Q waveforms are acquired and analysed offline to obtain the signal change to displacement ratio, known as calibration factor.

By definition I' is the position signal and Q' contains all signals orthogonal to position. Figure 8.7 shows that a systematic change in I' signal could change the I and Q values because of a relative phase fixed by the detector in between the reference and the IQ signals. In addition, the mismatch between the BPM dipole frequencies with respect to the reference cavity frequency generates a constant rotation of the I and Q signals which depends on the chosen sample on the waveform.

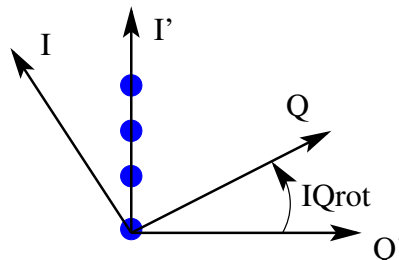

Figure 8.7 – IQ rotation. The blue dots represent the systematic change in position.

The position scan analysis allows to identify I' and Q' by the following procedure:

- Single samples in the waveform for I , Q and Ref signals are chosen.
- The I and Q values per pulse are divided by the Ref value, in order to remove the charge dependence. We have now I_n and Q_n .
- Plotting I_n vs Q_n allows one to find the IQ rotation angle, IQ_{rot} .
- The I_n and Q_n are counter rotated by the IQ_{rot} angle, to determine I' and Q' .

The ratio $I'/\Delta y$ in a.u./ μm is the cavity calibration factor, C_{bpm} .

It also gives the information of the beam center position, $I' = 0$, and the amplitude in μm of the constant orthogonal component Q'/C_{bpm} .

8.2.3 Angle scans

First a position scan should be done to identify I' and Q' signal. Then, a combination of piezo-movers setting keep the cavity center stable and changes the BPM pitch angle in systematic steps while the beam is running. See Appendix B.2.2 for the required mover settings for angle scans.

The I and Q signals are analysed applying the IQ_{rot} angle from the position scan, and it will show the change in I' and Q' while changing the angle. The Q'/θ_p and the calibration factor from the position scan are divided to find the angle to position ratio. It has been measured for IPBy giving $3.2 \mu\text{m}/\text{mrad}$ as expected from cavity parameters [65] (see Section 8.1.1).

8.2.4 Jitter acquisitions

The beam jitter is determined from measurements of the bunch position over several hundred pulses with static BPM mover settings.

Consider now the signal S as the sum of the two outputs from the cavity. The signal S for the vertical outputs of one BPM and one bunch is composed of:

$$S = y + i s_p \theta_p + s_{xy}(x + i s_y \theta_y) + x \theta_r \quad (8.9)$$

where i represents the $\pi/2$ phase difference, s_p is the sensitivity to pitch angle, s_{xy} is the inverse of X-Y isolation, s_y is the yaw angle sensitivity and $x, y, \theta_p, \theta_r, \theta_y$, are horizontal position, vertical position, pitch, roll and yaw angles of the BPM with respect to beam.

The signal S can be separated in real and imaginary parts:

$$S = (y + s_{xy}x + x\theta_r) + i(s_p\theta_p + s_{xy}s_y\theta_y) \quad (8.10)$$

The amplitude $|S|$ is the total contribution to signal and should be below the dynamic range of the first downmixing stage.

This signals are rotated by an arbitrary angle ϕ to obtain the I' and Q' at the phase shifter block.

$$\begin{aligned} S &= \underbrace{(y + s_{xy}x + x\theta_r)(\cos \phi + i \sin \phi)} + \underbrace{i(s_p\theta_p + s_{xy}s_y\theta_y)(\cos \phi + i \sin \phi)} \\ &= I' + Q' \end{aligned}$$

In the case of perfect IQ rotation ($\phi = 0$), all the imaginary (angle and others) component is removed from the real (position) component in the S signal. However, in practice this rotation could be achieved to a precision $\Delta\phi$, then, to first order

$$S = [(y + s_{xy}x + x\theta_r) - \Delta\phi(s_p\theta_p + s_{xy}s_y\theta_y)] + i[\Delta\phi(y + s_{xy}x + x\theta_r) + (s_p\theta_p + s_{xy}s_y\theta_y)] \quad (8.11)$$

At this point we will only be interested in the real part as it contains most of the vertical position signal.

$$\Re[S] = S_y = (y + s_{xy}x + x\theta_r) - \Delta\phi(s_p\theta_p + s_{xy}s_y\theta_y) \quad (8.12)$$

The last equation shows the contribution to vertical signal from the relative position of the BPM to the beam.

The mean value of the S_y signal over m bunch samples will be equal to

$$\langle S_y \rangle = [y_0 + (x_0 + \eta\delta)(s_{xy} + \theta_{r0})] - \Delta\phi[s_p\theta_{p0} + s_{xy}s_y(\theta_{y0} + \eta'\delta)] \quad (8.13)$$

where all parameters 0-index correspond to misalignments, η and η' are the spatial dispersion and angular dispersion optical functions, $\delta = 10^{-3}$ is the energy spread, and no beam rotation is considered. The alignment purpose is to make $\langle S \rangle = 0$.

The variance of the signal jitter $\sigma_{S_y}^2 = \langle S_y^2 \rangle - \langle S_y \rangle^2$ can be expressed as

$$\begin{aligned} \sigma_{S_y}^2 &= \sigma_{j_y}^2 + \sigma_{j_x}^2[s_{xy} + \theta_{r0}]^2 + (\Delta\phi)^2[s_p^2\sigma_{j_{y'}}^2 + s_{xy}^2s_y^2\sigma_{j_{x'}}^2] \\ &= \langle y^2 \rangle - y_0^2 + (\langle x^2 \rangle - x_0^2)[s_{xy} + \theta_{r0}]^2 + (\Delta\phi)^2[s_p^2(\langle y'^2 \rangle - y_0'^2 + s_{xy}^2s_y^2(\langle x'^2 \rangle - x_0'^2))] \end{aligned}$$

and subtracting all means effects

$$\sigma_{S_y}^2 = \langle y^2 \rangle + \langle x^2 \rangle[s_{xy} + \theta_{r0}]^2 + (\Delta\phi)^2[s_p^2\langle y'^2 \rangle + s_{xy}^2s_y^2\langle x'^2 \rangle] \quad (8.14)$$

Isolation X-Y ($1/s_{xy}$) was measured to be under 50dB, sensitivity to pitch (s_p) was measured to be $3.2\mu\text{m/mrad}$, and sensitivity to yaw (s_y) is $2.9\mu\text{m/mrad}$ estimated in similar way as s_p .

For a 1 nm contribution to beam size we get:

$$1 \text{ nm} \geq \sqrt{\langle x^2 \rangle}[s_{xy} + \theta_{r0}] = \sqrt{\langle x^2 \rangle}[1.880 \times 10^{-3} + \theta_{r0}] \quad (8.15)$$

$$1 \text{ nm} \geq \Delta\phi s_p \sqrt{\langle y'^2 \rangle} = 3.2\Delta\phi \sqrt{\langle y'^2 \rangle} \quad (8.16)$$

$$1 \text{ nm} \geq \Delta\phi s_{xy} s_y \sqrt{\langle x'^2 \rangle} = 5.453 \times 10^{-3} \Delta\phi \sqrt{\langle x'^2 \rangle} \quad (8.17)$$

where the BPM vertical ($3.7\text{mV}/\mu\text{m/nC}$) and horizontal ($2.2\text{mV}/\mu\text{m/nC}$) sensitivities have been used to translate voltage isolation X-Y to position scale, position jitter is in nm and angle jitter in μrad .

Tables 8.3-8.6 show the typical jitter magnitude at the beam waist and the farthest BPM (IPA) for the two optics with the largest angular jitter.

Using the above jitter magnitudes at the beam waist for the 10BX1BY optics, one can calculate that $\theta_{r0} \leq 0.6 \text{ mrad}$ and $|\Delta\phi| \leq 4.525 \text{ mrad}$ are required to 1 nm resolution.

The current precision of $|\Delta\phi|$ has been found to be 43 mrad by redoing 7 calibrations one after another. This is 10 times bigger than specified and could contribute to 3 to 4 nm to the position jitter at the IP because it adds up in quadrature.

Jitter	10%	20%
$\sigma_{yj}(\text{nm})$	3	7
$\sigma_{xj}(\text{nm})$	283	565
$\sigma_{y'j}(\mu\text{rad})$	34	69
$\sigma_{x'j}(\mu\text{rad})$	71	141

Table 8.3 – Jitter at beam waist with 1BX1BY optics.

Jitter	10%	20%
σ_{yj} (nm)	3	7
σ_{xj} (nm)	894	1787
$\sigma_{y'j}$ (μ rad)	34	69
$\sigma_{x'j}$ (μ rad)	22	44

Table 8.4 – Jitter at beam waist with 10BX1BY optics.

Jitter	10%	20%
σ_{yj} (nm)	5766	11531
σ_{xj} (nm)	11866	23733
$\sigma_{y'j}$ (μ rad)	0	0
$\sigma_{x'j}$ (μ rad)	1	3

Table 8.5 – Jitter at IP with 1BX1BY optics.

Jitter	10%	20%
σ_{yj} (nm)	5766	11531
σ_{xj} (nm)	3856	7713
$\sigma_{y'j}$ (μ rad)	0	0
$\sigma_{x'j}$ (μ rad)	5	10

Table 8.6 – Jitter at IPA with 10BX1BY optics.

Chapter 9

System characterization and Preliminary Results

In this chapter I present the results of the studies in the vertical plane of the piezo-movers calibration factor per block, the BPM signal calibration per BPM and the dynamic range measurement for the IPB system. The resolution is estimated by the analysis of the electronics noise limit and the beam trajectory reconstruction from jitter acquisitions. The system is also used to test feedback in one BPM.

Finally the status of the BPM system is shown with remarks about the ongoing work to improve the current performance.

9.1 Calibration

The calibration factor is obtained per cavity and in the vertical plane y by measuring the position signal change as a function of the physical displacement of the cavity. Two factors are used to obtain each calibration : the movers' displacement versus voltage setting C_m [$\mu\text{m}/\text{V}$] and the cavity response versus voltage setting C_c [a.u./V]. Therefore the cavity calibration factor is $C_{bpm} = C_c/C_m$ [a.u./ μm].

9.1.1 Movers' Calibrations C_m

Prior to installation, the movers' displacement versus voltage setting was measured per BPM block. An interferometer with better than 1 nm resolution was used to measure the BPM vertical position as shown in Fig. 9.1a. As the head is located on top of the BPM, positive displacement implies negative change in the intereferometer readout. Four cycles are shown in Fig. 9.1b, two descending and two rising, covering the total dynamic range and divided in 100 steps, with a 3 s settling time between steps.

Block AB movers, Cedrat

Linearity was tested in the four cycles with feedback. Fig. 9.2a shows the mover step and Fig. 9.2b shows the residuals from the linear fitting substraction on each cycle.

The calibration mean from these 4 cycles is $C_{mAB} = (-31.015 \pm 0.012)\mu\text{m}/\text{V}$. This value is valid for ranges were the residual is constant enough, therefore, it is recommended to use the

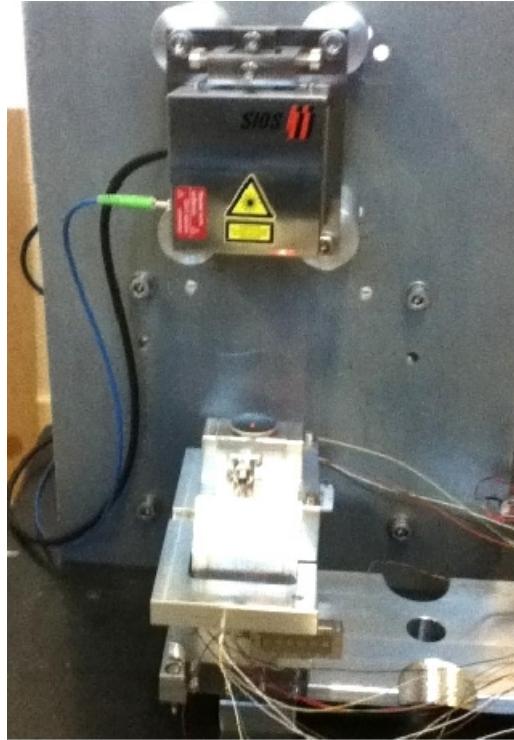

(a) Picture of SIOS interferometer used to test the movers. Precision is better than 1 nm.

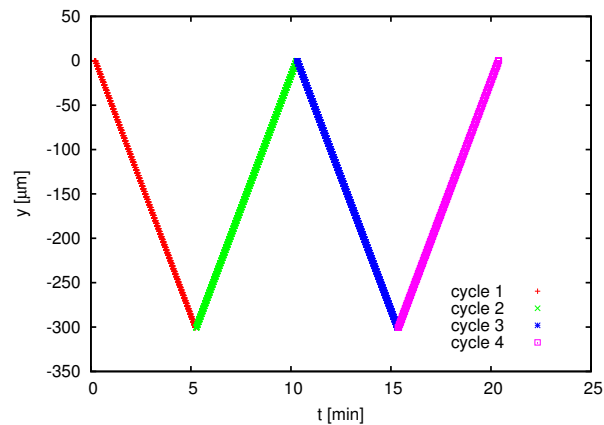

(b) Four cycles are performed over the entire dynamic range of movers.

Figure 9.1 – Movers calibration test setup for the vertical plane.

movers with voltage settings in the middle of the total dynamic range and to scan over less than 1 V. Improved calibration over full the range can be obtained using a non-linear function.

The step stability was tested by moving back and forth the voltage setting hundreds of times. Figure 9.3a shows that 10 nm steps are observable and Fig. 9.3b shows 1.1 nm of stability on each setting.

Coupling effect of horizontal displacement on the vertical plane was also tested. Figure 9.4 shows a vertical position variation of $2.5 \mu\text{m}$ (1%) over the full horizontal dynamic range.

Only the readbacks from the control box are available after installation indicating current mover position. Results from readback linearity with respect to voltage setting within ranges below 1 V show that readbacks are limited by electrical noise of 0.8 mV limiting the calibration steps. This however does not provide information of the movers stability because the feedback loop is closed inside the control box. The noise is Gaussian, and its effect on

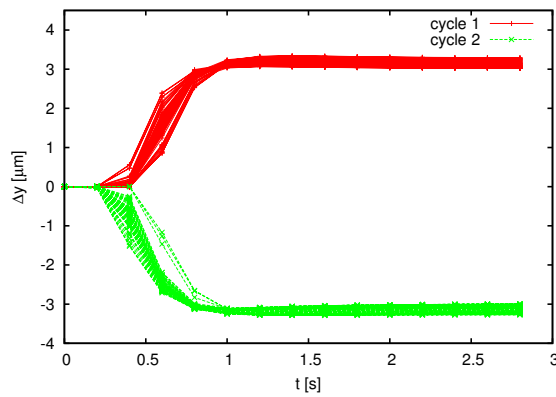

(a) Settling speed with feedback for Cedrat movers.

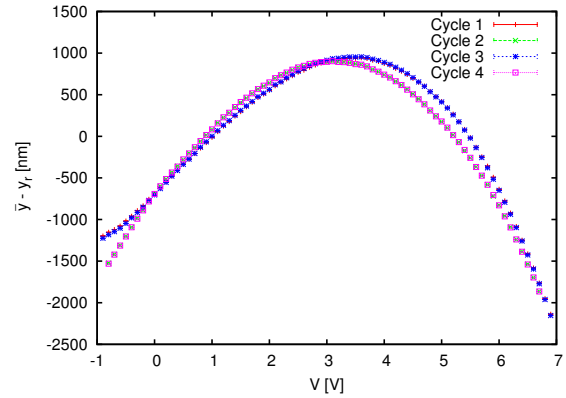

(b) Residual non-linearity (with fb), after subtraction of linear fitting on cedrat movers.

Figure 9.2 – Block AB movers, linearity test over four cycles.

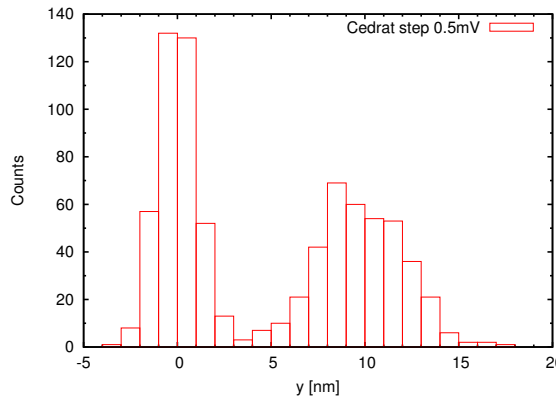

(a) Minimum voltage setting variation back and forth tested was 0.5 mV.

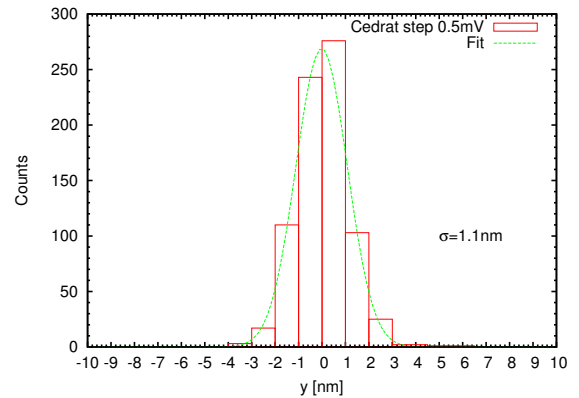

(b) Stability at fixed voltage setting.

Figure 9.3 – Block AB movers minimum step and stability.

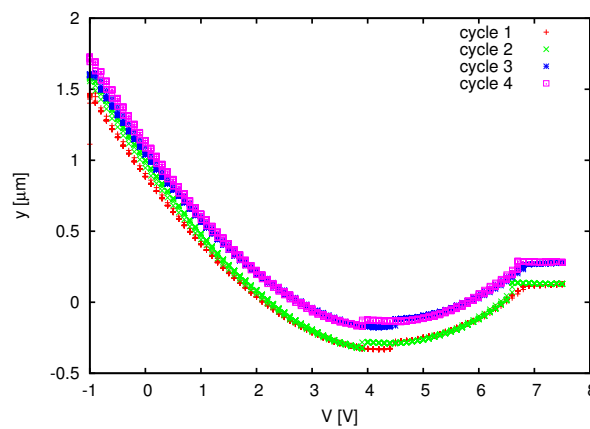

Figure 9.4 – Horizontal to vertical coupling of movers motion.

calibration can be minimized by averaging over several readings.

Block C movers, PI

Linearity was tested in the four cycles with feedback. Figure 9.5a shows the settling time of the feedback and Fig. 9.5b shows the residuals from the linear fitting subtraction on each cycle.

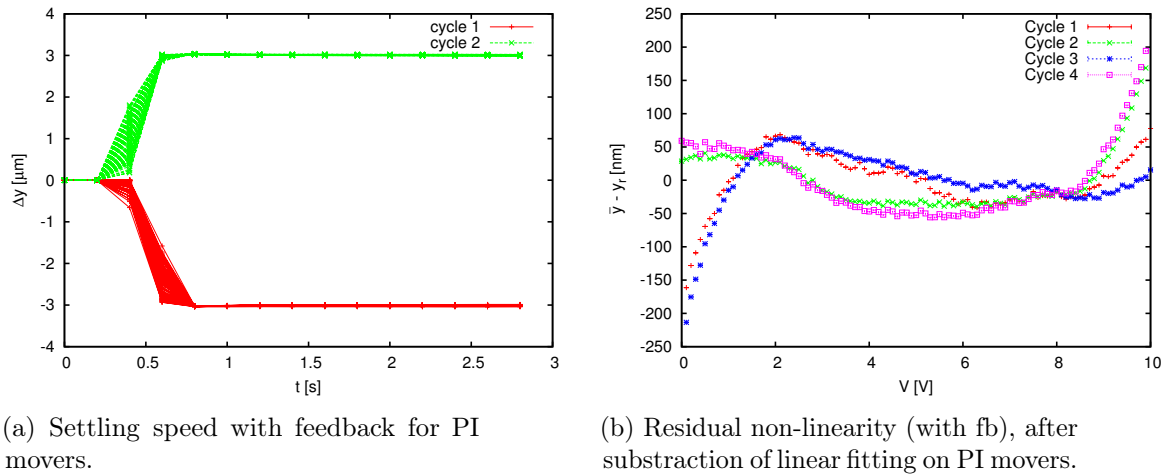

Figure 9.5 – Block C movers, linearity test over four cycles.

The calibration mean from these 4 cycles is $C_{mC} = (30.002 \pm 0.007) \mu\text{m}/\text{V}$. This value is valid for ranges where the residual is constant enough, therefore, it is recommended to use the movers with voltage settings in the middle of the total dynamic range and/or scan over less than 1 V.

The step stability was tested by moving back and forth the voltage setting hundreds of times. Fig. 9.6a shows that 20 nm steps can be resolved and Fig. 9.6b shows 1.13 nm of stability on each setting with feedback.

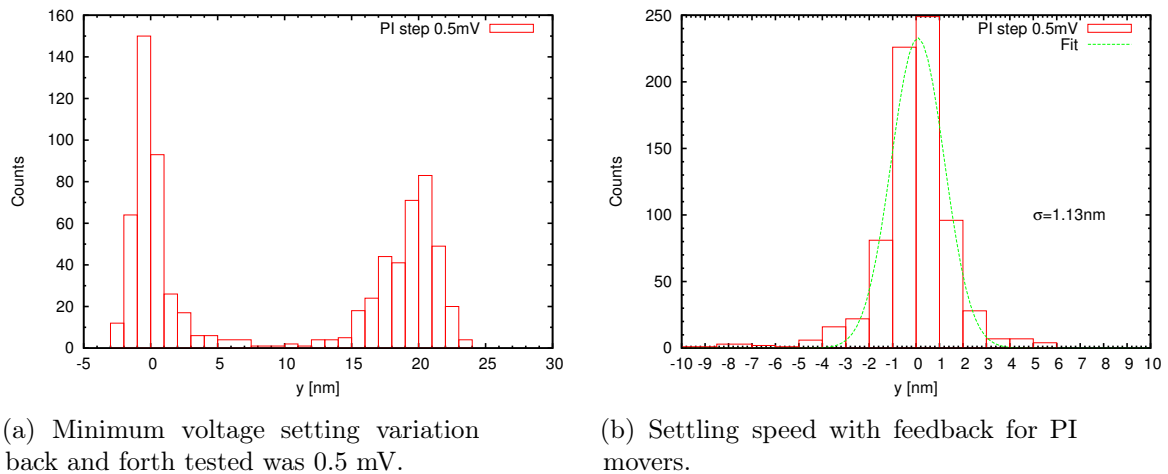

Figure 9.6 – Stability at fixed voltage setting.

Coupling effect of horizontal displacement on the vertical plane was also tested. Fig (9.7) shows vertical position variation of $3 \mu\text{m}$ (1%) of total horizontal dynamic range.

In the same way as with previous block, only the readbacks from the control box are available after installation indicating current mover position. Results from readback linearity with respect to voltage setting within ranges below 1 V show that readbacks are limited by electrical noise of 5.3 mV limiting the calibration steps. This however does not provide information of the movers stability because the feedback loop is closed inside the control box. The noise is

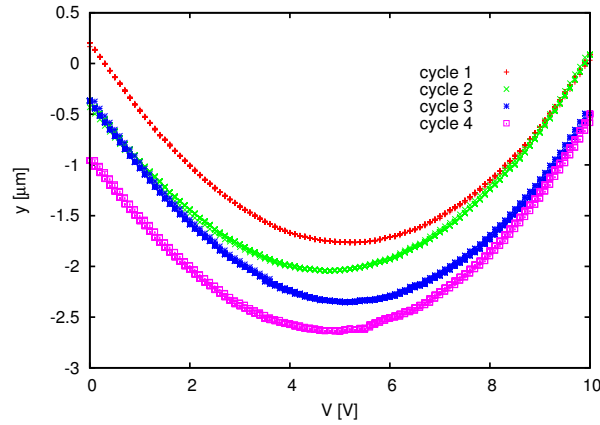

Figure 9.7 – Horizontal to vertical movers coupling.

Gaussian, and its effect on calibration can be minimized by averaging over several readings.

9.1.2 Cavity response calibration C_c

During beam time the cavity position is systematically changed and the amplitude of the cavity output signal is measured. Calibration is calculated from the movers voltage readbacks and choosing the signal peak from the acquired waveform, giving the factor $C_c = I'/V$ [a.u./V], and the IQ rotation angle ϕ .

Input signal can be attenuated from 0 dB to 70 dB in order to keep it inside of the electronics linear response and acquisition system limits. The system response with attenuation change can be seen in Fig. 9.8. The variation of the calibration is within $\pm 5\%$ for charge between $(0.4 \sim 0.5) \times 10^{10}$ particles, except for IPBy at 0 dB. The reason for this is a saturation of the electronics, as explained in Section 9.2.

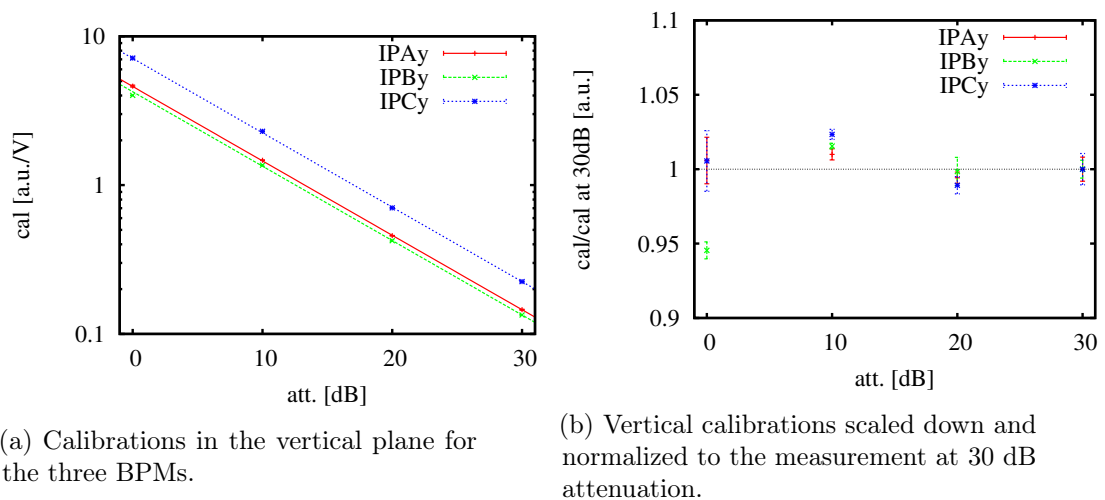

(a) Calibrations in the vertical plane for the three BPMs.

(b) Vertical calibrations scaled down and normalized to the measurement at 30 dB attenuation.

Figure 9.8 – Calibrations as a function of attenuation.

9.2 Dynamic Range

Dynamic range is defined in this section as the movers' voltage range in which the cavity response is linear within a tolerance, and where it therefore can be translated to position using the calibration factor, c_m , obtained in Sect. 9.1.1. The dynamic range is limited by the linear response of the cavity sensitivity, the processing electronics and the acquisition system.

9.2.1 Acquisition System

Every study case has been performed with signals inside the acquisition system dynamic range, described in 8.1.4. The initial FONT board has been recently replaced by a dedicated SIS digitizer with larger and configurable voltage range. This is no longer a limitation.

9.2.2 Processing electronics and cavity sensitivity

The processing and cavity response are combined in the calibration study showing linearity within $\pm 5\%$ as described in Sect. 9.1.2. However, Fig. 9.8b shows that IPBy calibration is just outside this range at 0 dB attenuation. In order to explain this behaviour the Q' signals from calibrations are shown in Fig. 9.9. A visible difference between IPAy and IPCy with respect to IPBy can be seen. The decay of IPAy and IPCy Q' signals is consistent with system resolution studies shown in Sect. 9.3. However, the IPBy Q' signal remains close to (0.2 ~ 0.3) V of movers voltage in the attenuation range from 0 to 20 dB, equivalent to (6.2 ~ 9.3) μm using C_{mAB} .

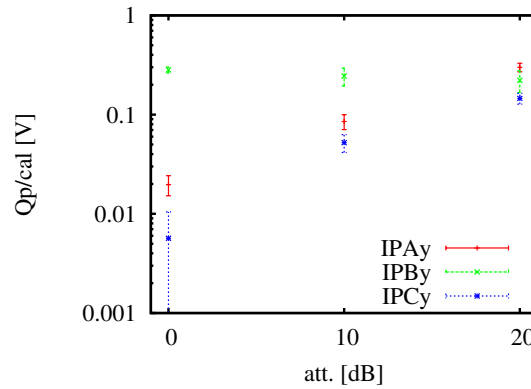

Figure 9.9 – Effect of attenuation in Q' signals from calibrations. Error bars are RMS.

In the same way, the IPBy calibration versus charge is shown in Fig. 9.10, where the calibration values have been normalized to the minimum charge and attenuation is fixed at 10 dB. The calibration constant decays by more than 5% at charges above 0.4×10^{10} particles.

The maximum amplitude of the signal $A = \sqrt{I'^2 + Q'^2}$ has been used to obtain the dynamic range. From the non-saturated calibration at 0.36×10^{10} and 10 dB att. the signals I' and Q' are used to obtain $A = 0.36$ V of movers range, equivalent to 11 μm using c_{mAB} , where the cavity calibration c_B varies less than $\pm 5\%$. Similar dynamic ranges, in the order of 8 to 10 μm , have been found for IPAy and IPCy, however they lack the charge scan.

The IPBy Q' signal fills up almost all dynamic range at 10 dB attenuation and 0.4×10^{10} particles, and it is saturating the processing electronics at 0 dB.

To predict the measured dynamic range of IPBy it is necessary to put extra 6dB of

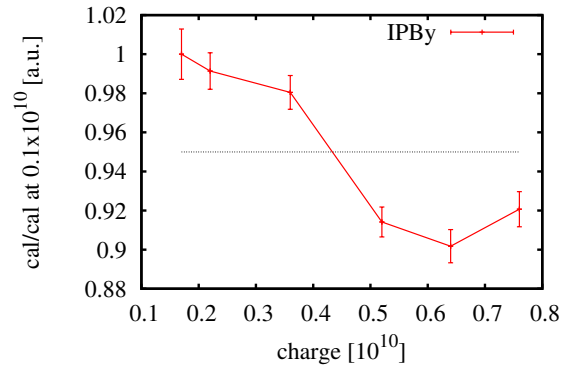

Figure 9.10 – IPBy Calibration versus charge normalized to the calibration at minimum charge.

attenuation in the processing electronics gain model (Sect. 8.1.2) . At the moment, it has been attributed to lower than expected sensitivity of the cavities in Section 9.3.2 and/or cable loss in the processing electronics interconnection.

9.3 Resolution

Resolution is measured in nm using the calibration results from Sect. 9.1. It is limited by the cavity sensitivity, the electronics noise floor and the acquisition system resolution.

9.3.1 Acquisition System

The acquisition system resolution is specified in Sect. 8.1.4. Only the oscilloscopes had lower than required resolution, however, they have already been replaced by a dedicated SIS digitizer. This is no longer a limitation.

9.3.2 Noise floor and cavity sensitivity

The BPMs, processing electronics and connections along the BPM signal path generate noise limiting the minimum detectable waveform. This minimum is estimated by scanning the measured jitter versus the attenuation value.

At large attenuations the noise floor is bigger than beam jitter at the BPM, while at low attenuations is the opposite. There is an inflection point where both are relevant. The cavity calibrations are used to translate the measurements into nm.

The jitter acquisition is the measurement of bunch position over several hundreds of pulses with a fixed BPM position. The readings from the 3 BPMs are shown in Fig. 9.11. Jitter for the three BPMs is in the order of 300 ~ 400nm, consistent with true beam jitter at that day (because the beam was not tuned after a DR extraction kicker issue). At 40 dB the noise is larger than beam signal and by extrapolation the resolution limit per BPM is 13 nm for IPAy, 11 nm for IPBy, and 23 nm for IPCy at 0 dB.

It is also clear that IPC shows a worse resolution limit than IPA or IPB. Two possibilities arise: the electronics noise is larger for IPC or the sensitivity is lower.

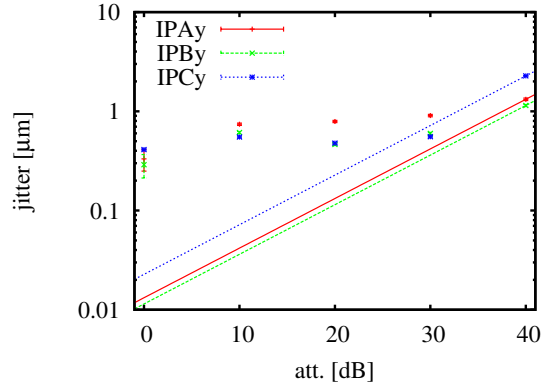

Figure 9.11 – Jitter measurement for the 3 BPMs.

Noise floor

Jitter measurements at 60 dB and 70 dB attenuation with 0.4×10^{10} particles have shown that, after subtraction of known gains from first, second down-mixing stages and hybrid, the noise floor value varies by only ± 1 dB among BPMs.

Although, it can not be considered a direct measurement of the processing noise floor as in [66] because additional losses are not included, it does indicate that the noise floor is similar for the three BPMs and that it is not the explanation for the discrepancy seen in Fig. 9.11 between IPCy when compared to IPAy and IPBy.

A lower limit of 10 nm on the resolution per BPM results from the processing electronics noise floor in the current state.

Cavity sensitivity

Cavity sensitivity and processing electronics gain change the calibration factors. Due to the 6 dB mismatch between the dynamic range measured and predicted for IPBy, as shown in Sect. 9.2, and the lack of charge scans for IPAy and IPCy, it is not possible to conclude about the total gain without making assumptions.

However, the signal decay time from waveforms gives information about the cavity performance. The measurement of the decay time τ described in Sect. 8.1.1 shows a 6 ns decay for IPCy compared to 11 ns and 12 ns for IPAy and IPBy. This difference indicates power losses which might be attributed to partially tightened bolts during mechanical assembly of the BPM. In addition, 11 ns is short when compared with expected 17 ns from design. The effect on cavity sensitivity is still under investigation.

The electronics gain needs to be measured per component and losses need to be identified in order to conclude whether the noise limit comes from processing electronics or the reduced cavity power.

9.3.3 Resolution by trajectory reconstruction

The system resolution could be estimated by the reconstruction of beam trajectories. Two BPMs are used to measure the bunch position and to predict the measurement at the third BPM. The residuals difference between prediction and measurement will depend on each BPM resolution.

Large β^* optics has been used to obtain similar beam jitter and dynamic range in the study of the three BPMs at the same time.

Geometrical method

As longitudinal distances are known within a ± 0.1 mm over 250 mm, i.e. better than 0.1% precision, then, geometrical factors can be used to predict the beam trajectory [67], assuming that all three BPMs have the same resolution. The advantage of this method is that it is independent from beam optics as it does not require to fit parameters to do predictions. The following is an explanation of the method.

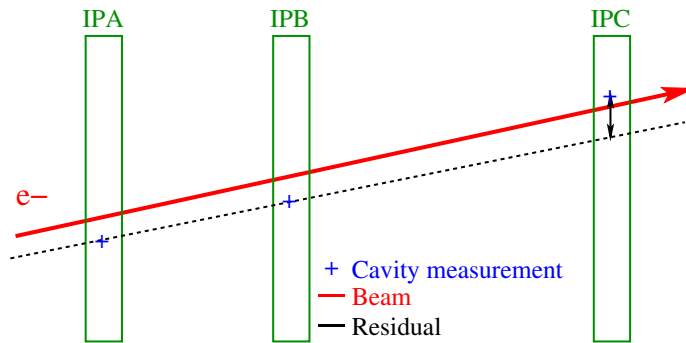

Figure 9.12 – Three BPM resolution. The position measurement at IPA and IPB are used to extrapolate to IPC. The residual from subtraction of the measured and extrapolated position at IPC is used to estimate the system resolution.

Being $f_C(y_A, y_B)$ the prediction at IPC from the measurement at IPA and IPB using the relative distances between the BPMs as in Fig. 9.12, its evaluation is subtracted from the measurement in IPC as in Eq. (9.1). It would be possible to calculate the theoretical propagation of uncertainty of the residual, $\sqrt{\langle R_t^2 \rangle}$, as in Eq. (9.2), from the individual resolution r_A, r_B , and r_C if they were known.

$$R_t = y_C - f_C(y_A, y_B) \quad (9.1)$$

$$\sqrt{\langle R_t^2 \rangle} = \sqrt{\left(\frac{\partial R_t}{\partial y_A}\right)^2 r_A^2 + \left(\frac{\partial R_t}{\partial y_B}\right)^2 r_B^2 + \left(\frac{\partial R_t}{\partial y_C}\right)^2 r_C^2} \quad (9.2)$$

Assuming that each BPMs position measurement is independent and Gaussian distributed, the standard deviation of the residuals distribution σ_{R_m} from measurements should be equal to the theoretical value $\sqrt{\langle R_t^2 \rangle}$. Equation (9.4) becomes Eq. (9.5) by assuming that each BPM has the same resolution $r_A = r_B = r_C = r$. The factor in the square root in Eq. (9.5) does no longer contain any unknowns, as R_t is a linear extrapolation using distances, and it will be a constant, g , multiplying the standard deviation from measurements to estimate the BPM resolution r . This constant is known as the *geometrical factor*.

$$\frac{\sigma_{Rm}}{\sqrt{\langle R_t^2 \rangle}} = 1 \quad (9.3)$$

$$\frac{\sigma_{Rm}}{\sqrt{\left(\frac{\partial R_t}{\partial y_A}\right)^2 r_A^2 + \left(\frac{\partial R_t}{\partial y_B}\right)^2 r_B^2 + \left(\frac{\partial R_t}{\partial y_C}\right)^2 r_C^2}} = 1 \quad (9.4)$$

$$\frac{\sigma_{Rm}}{\sqrt{\left(\frac{\partial R_t}{\partial y_A}\right)^2 + \left(\frac{\partial R_t}{\partial y_B}\right)^2 + \left(\frac{\partial R_t}{\partial y_C}\right)^2}} = r \quad (9.5)$$

$$g\sigma_{Rm} = r \quad (9.6)$$

The equations used for position prediction are shown in Eq. (9.7), where the coefficients are calculated from the longitudinal distance among BPMs.

$$\begin{aligned} f_A(y_B, y_C) &= 1.463y_B - 0.463y_C \\ f_B(y_A, y_C) &= 0.683y_A + 0.317y_C \\ f_C(y_A, y_B) &= -2.156y_A + 3.156y_B \end{aligned} \quad (9.7)$$

Following the same example with IPC, it is possible to plot the measured value versus the prediction to find the slope and correlation. Ideally, both, slope and correlation are one, however they are resolution limited.

Being C_m the measured value at IPC, C_p the predicted value at IPC from the measurement in other cavities, and $R = C_m - C_p$ the residual from subtraction, it is possible to obtain the slope, m , as in Eq. (9.8). The factor $\langle C_m \cdot R \rangle$ indicates the over or under prediction of the measurement at IPC.

$$m = 1 - \frac{\langle C_m \cdot R \rangle}{\langle C_m^2 \rangle} \quad (9.8)$$

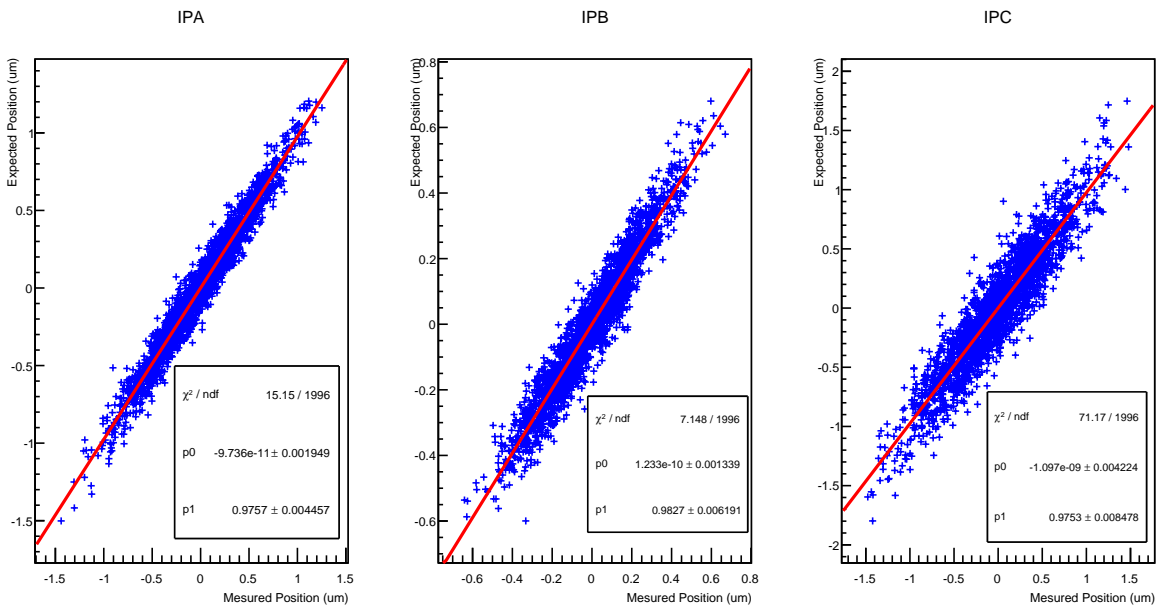

Figure 9.13 – Correlation of the three BPMs measurements and predictions.

Figure 9.13 shows the correlation between the measured and predicted position at 4×10^{10} particles per bunch and 0 dB attenuation, where calibration has been modified by +3.7%, +10.9% and -2.8% for IPAy, IPBy and IPCy respectively in order to obtain unitary slopes within 2%.

The large correction made in the IPBy calibration could be explained by the results shown in Sect. 9.1.2, and the others lay within calibration precision limits.

The measured jitter and the residuals from subtracting the predicted value are gaussian. The jitter values, slopes and correlations of predicted vs measured positions, and geometrical factors are shown in Table 9.1.

The resolution per BPM estimated with this method by calculating the residuals on each one of the three BPMs is (47.4 ± 0.8) nm.

Parameter	IPAy	IPBy	IPCy
Jitter [μm]	0.437	0.216	0.498
Slope	0.9757 ± 0.0044	0.9827 ± 0.0062	0.9753 ± 0.0085
Correlation	0.9798	0.9626	0.9322
Geometrical factor	0.5457	0.7988	0.2531
R [nm]	87.2 ± 1.4	59.7 ± 1.0	185.3 ± 2.9
Resolution [nm]	47.6 ± 0.8	47.7 ± 0.8	46.9 ± 0.7

Table 9.1 – Results from trajectory reconstruction.

9.4 Feedback

During recent tests, a two bunch beam train was used with a bunch spacing of 215.6 ns, and the signals from IPBy were input to the feedback system. Feedback has been tested by the FONT Group [68] obtaining a reduction of beam jitter down to 67 nm, compatible with the resolution shown in Section 9.3.

9.5 Present Status and Prospects

Table 9.2 show a summary of the current IP-BPM results.

The efforts to improve over the results listed above are continuous. Precisely now, two improvements have been done on the system. First, the horizontal and vertical planes can be analyzed simultaneously, such that data can be checked for coupling from one plane to another. Second, filters are added to the system in order to reduce the effect of the mismatch between frequencies in the down-mixing process.

At the moment, the first limitation to improve the resolution is the noise limit. The target is to explore the origin of the noise and characterize the gain along the signal path. That will allow to conclude on the cavity sensitivity.

The IPBy Q' signal is a second limitation to avoid saturation and inaccurate calibration. The reason is unknown for the moment, but it could be generated by an angular misalignment between cavities or a large static monopole signal. I think the monopole would affect also the horizontal plane too, therefore the upgraded electronics will help to diagnose this aspect.

In all cases, the electronics needs to be upgraded because it saturates at half the bunch charge

PARAMETER	REQUIREMENT	STATUS	Comments
Resolution	$\sim \text{nm}@1 \times 10^{10}$	$< 50 \text{nm}@0.4 \sim 0.5 \times 10^{10}$	Calibration factors within 5% linearity BPM/Electronics noise : 10 nm per cavity IPC sensitivity and/or gain : +20nm X to Y coupling is still unexplored
Dynamic Range	$\sim 10 \mu\text{m} + \text{extra}@0 \text{ dB att.}$	$9 \sim 11 \mu\text{m}@10 \text{ dB att.}$	Cavity response is linear within 5% Electronics starts to saturate at $0.4 \times 10^{10}@10 \text{ dB att.}$ IPBy Q' signal saturates at 0 dB
Compatibility	IPBSM, EPICS	In progress	Calibration Software : Initial version released and in use. Requires comparison with offline results. Jitter analysis Software : Initial version re- leased and in use. Requires comparison with offline analysis. IP-BSM, requires study of resolution vs low charge, $0.1 \sim 0.5 \times 10^{10}$
Feedback	Operative	Tested	Jitter reduction to 67 nm. Limited by BPM resolution.

Table 9.2 – IPBPMs status.

required. Extra dynamic range in electronics for residual Q' signals would solve the problem.

Under current conditions the characterization of the resolution at low charges is possible, if data are synchronized with the IP-BSM system, then it will provide useful information when tuning the beam size at the IP, leading to finally including the IPBPM as a regular measurement instrument.

Part IV

Conclusions, Results and Perspectives

Conclusions, Results and Perspectives

Linear colliders feature nanometer IP beam spot sizes in order to achieve design luminosities.

The CLIC and ILC lattices have been designed using the local or non-local chromaticity correction schemes. A new chromaticity correction scheme is proposed to the local and non-local chromaticity corrections for CLIC 500 GeV. This lattice has been design and diagnose. The main issue in the current state is the non-zero second order dispersion in the FD region where a strong sextupole is used to correct the remaining geometrical components. It could be solved by cancelling the second order dispersion and its derivative before the FD.

Radiation effects are crucial during the design stage of the lattices, where effects can be evaluated by tracking particles through the lattice or by analytical approximations. Both, radiation and optic parameters, during the design optimization process, radiation phenomena is reviewed. This document addressed two particular radiation phenomena: the Oide effect [3] and the radiation caused by bending magnets [4].

In the Oide effect, radiation in the final quadrupole sets a limit on the vertical beamsizes. Only for CLIC 3 TeV this limit is significant, therefore two possibilities have been explored to mitigate its contribution to beam size: double the length and reduce the QD0 gradient, or the integration of a pair of octupoles before and after QD0.

The best result with octupoles demonstrated vertical beam size reduction of $(4.3 \pm 0.2)\%$, with little or negative impact on luminosity. The correction scheme is currently limited by the phase advance and β_y/β_x ratio between correctors. It may be possible to improve its performance by slicing QD0.

The radiation in bending magnets has been reviewed. The analytical result in [4] was generalized to the case with non-zero alpha at the IP and non-zero dispersion, required during the desing and luminosity optimization process. The closed solution for one dipole and one dipole with a drift was compared with the tracking code PLACET [5] resulting in the improvement of the tracking code results. Finally the model validity for the FFS design is analyzed concluding an agreement within $\pm 10\%$ between the theoretical contribution to beam size and the tracking.

ATF serves as R&D platform for the requirements of linear accelerators, in particular ILC. The beam size reduction using the local chromaticity correction is explored by an extension of the original design, called ATF2 with two goals: (**goal 1**) achieve 37 nm of vertical beam size at the IP and (**goal 2**) the stabilization of the IP beam position at the level of few nanometres. Since 2014 beam size of 44 nm are achieved as a regular basis at charges of about 0.1×10^{10} particules per bunch. Possible contributions to beam size are: (1) the increase of the incoming beam emittance along the ATF2 line, (2) systematic errors and resolution limitations on the beam size monitor, (3) beam drift/jitter beyond the tolerable margin and (4) undetected optics mismatch. Last two issues can be adressed by measuring the beam trajectory in the IP Region after the Final Doublet. In addition, looking forward to **goal 2**, beam position measurement is a requirement for beam stabilization.

Therefore, a set of three cavities (IPA, IPB and IPC), two upstream and one downstream of the nominal IP, were installed and are used to measure the beam trajectory in the IP region, thus providing enough information to reconstruct the bunch position and angle at the IP.

The results of the studies in the vertical plane of the cavities calibration show linearity within 5% over two orders of magnitude of signal attenuation. The minimum resolution achieved is just below 50 nm at 0.4×10^{10} particules per bunch with a set of electronics imposing a noise limit on resolution of 10 nm per cavity. The dynamic range is 10 μm at 10 dB attenuation and 0.4×10^{10} particules per bunch, indicating the need to upgrade the electronics. The integration to the ATF tuning instruments is ongoing. Nonetheless, feedback has been tested resulting in reduction of beam jitter down to 67 nm, compatible with resolution.

These results are for the moment far from the required specifications with nominal optics of 1 nm resolution over 10 μm dynamic range at 1.0×10^{10} particules per bunch. Two improvements have been done on the system since this study. First, the horizontal and vertical planes can be analyzed simultaneously, such that data can be checked for coupling from one plane to another. Second, filters are added to the system in order to reduce the effect of the mismatch between frequencies in the down-mixing process.

Appendix A

The primitive \mathcal{F}

$$\begin{aligned}
\mathcal{F} = & \frac{1}{1209600.0} \{ 1323 \cos(5\sqrt{k}L) - 675 \cos(7\sqrt{k}L) \\
& + \sqrt{k}L(378000 \sin(\sqrt{k}L) + 21000 \sin(3\sqrt{k}L) - 7560 \sin(5\sqrt{k}L)) \\
& + \sqrt{kl}^* [23625 \sin(\sqrt{k}L) + 4725 \sin(3\sqrt{k}L) - 14175 \sin(5\sqrt{k}L) + 4725 \sin(7\sqrt{k}L) \\
& + \sqrt{k}L(-37800 \cos(5\sqrt{k}L)) \\
& + (\sqrt{k}L)^2(-75600 \sin(3\sqrt{k}L) + 226800 \sin(\sqrt{k}L))] \\
& + (\sqrt{kl}^*)^2 [-49707 \cos(5\sqrt{k}L) + 14175 \cos(7\sqrt{k}L) \\
& + \sqrt{k}L(1587600 \sin(\sqrt{k}L) - 172200 \sin(3\sqrt{k}L) + 68040 \sin(5\sqrt{k}L))] \\
& + (\sqrt{kl}^*)^3 [-80325 \sin(\sqrt{k}L) - 144725 \sin(3\sqrt{k}L) + 82215 \sin(5\sqrt{k}L) - 23625 \sin(7\sqrt{k}L) \\
& + \sqrt{k}L(37800 \cos(5\sqrt{k}L)) \\
& + (\sqrt{k}L)^2(680400 \sin(\sqrt{k}L) - 126000 \sin(3\sqrt{k}L))] \\
& + (\sqrt{kl}^*)^4 [68985 \cos(5\sqrt{k}L) - 23625 \cos(\sqrt{k}L) \\
& + \sqrt{k}L(2041200 \sin(\sqrt{k}L) - 205800 \sin(3\sqrt{k}L) + 37800 \sin(5\sqrt{k}L))] \\
& + (\sqrt{kl}^*)^5 [-458325 \sin(\sqrt{k}L) - 43225 \sin(3\sqrt{k}L) - 25893 \sin(5\sqrt{k}L) + 14175 \sin(7\sqrt{k}L) \\
& + \sqrt{k}L(68040 \cos(5\sqrt{k}L)) \\
& + (\sqrt{k}L)^2(680400 \sin(\sqrt{k}L) - 25200 \sin(3\sqrt{k}L))] \\
& + (\sqrt{kl}^*)^6 [-945 \cos(5\sqrt{k}L) + 4725 \cos(7\sqrt{k}L) \\
& + \sqrt{k}L(831600 \sin(\sqrt{k}L) - 12600 \sin(3\sqrt{k}L) - 37800 \sin(5\sqrt{k}L))] \\
& + (\sqrt{kl}^*)^7 [(-354375) \sin(\sqrt{k}L) + 5425 \sin(3\sqrt{k}L) - 1323 \sin(5\sqrt{k}L) - 675 \sin(7\sqrt{k}L) \\
& + \sqrt{k}L(-7560 \cos(5\sqrt{k}L)) \\
& + (\sqrt{k}L)^2(226800 \sin(\sqrt{k}L) + 25200 \sin(3\sqrt{k}L))] \\
& + \cos(\sqrt{k}L)((\sqrt{kl}^*)^2 + 1)(4725)[(\sqrt{kl}^*)^5(\sqrt{k}L)(80) \\
& + (\sqrt{kl}^*)^4(155 - 48(\sqrt{k}L)^2) \\
& + (\sqrt{kl}^*)^3(\sqrt{k}L)(64) \\
& + (\sqrt{kl}^*)^2(182 - 96(\sqrt{k}L)^2) \\
& + \sqrt{kl}^*(-16\sqrt{k}L) \\
& + (\sqrt{k}L)^2(-48) + 75] \\
& + \cos(3\sqrt{k}L)(-175)[(\sqrt{kl}^*)^7(\sqrt{k}L)(120) \\
& + (\sqrt{kl}^*)^6(3)(144(\sqrt{k}L)^2 + 71) \\
& + (\sqrt{kl}^*)^5(\sqrt{k}L)(744) \\
& + (\sqrt{kl}^*)^4(720(\sqrt{k}L)^2 + 347) \\
& + (\sqrt{kl}^*)^3(\sqrt{k}L)(-24) \\
& + (\sqrt{kl}^*)^2(144(\sqrt{k}L)^2 - 473) \\
& + \sqrt{kl}^*(-648)\sqrt{k}L \\
& + (\sqrt{k}L)^2(-144) - 31] \}
\end{aligned}$$

In order to confirm that the code implementation gave the same result than the original double integral, random values were assigned to \sqrt{kl}^* and \sqrt{kL} and both expressions, the solved and the double integral, were numerically evaluated with difference lower than 10^{-3} relative.

Appendix B

IPBPMs Movers

B.1 System Description

At the ATF2 IP region, inside the vacuum chamber, the BPMs positioning system has been installed during the first two weeks of July 2013. It moves two independent blocks: Block IPAB and Block IPC. Each block has three degrees of freedom: vertical, lateral and pitch angle, using using four piezo-movers per block: three vertical and one horizontal.

Movers made by the german company “PI” electronics moves IPC and the french company “Cedrat Technologies” moves IPAB.

B.1.1 The Piezo Movers

Piezo mover changes its position as a function of voltage. Each one of the eight movers has its own control electronics block composed of:

- The piezo-mover to generate the displacement.
- The strain gauge, used by the control box for feedback.
- The control box (module provided by the manufacturer) to:
 - Set piezo-mover high voltage to induce the motion of the piezo-mover.
 - PI module E-621
 - CEDRAT module LA75
 - Read strain gauge to know the piezo-mover position.
 - PI module E-621 (same as control)
 - CEDRAT module SG75
 - Set feedback operation (ON/OFF).
 - Set control mode: internal or external setting point. External mode is used.
- PLC channel to:
 - Set voltage to the setting point input in the control box.
 - Read voltage from control box output proportional to piezo-mover position.

B.1.2 Electrical connections

Figure B.1 shows the electrical connections diagram between the movers displacement system components. It shows the connexion to the local network by Ethernet, the DACs and ADCs used to set and read the voltage levels, the connection to the dedicated control boxes, a linking box to match the cable connectors, the 25 m cable to connect to the vacuum chamber flanges

inside the ATF tunnel, the movers, and temperature probes.

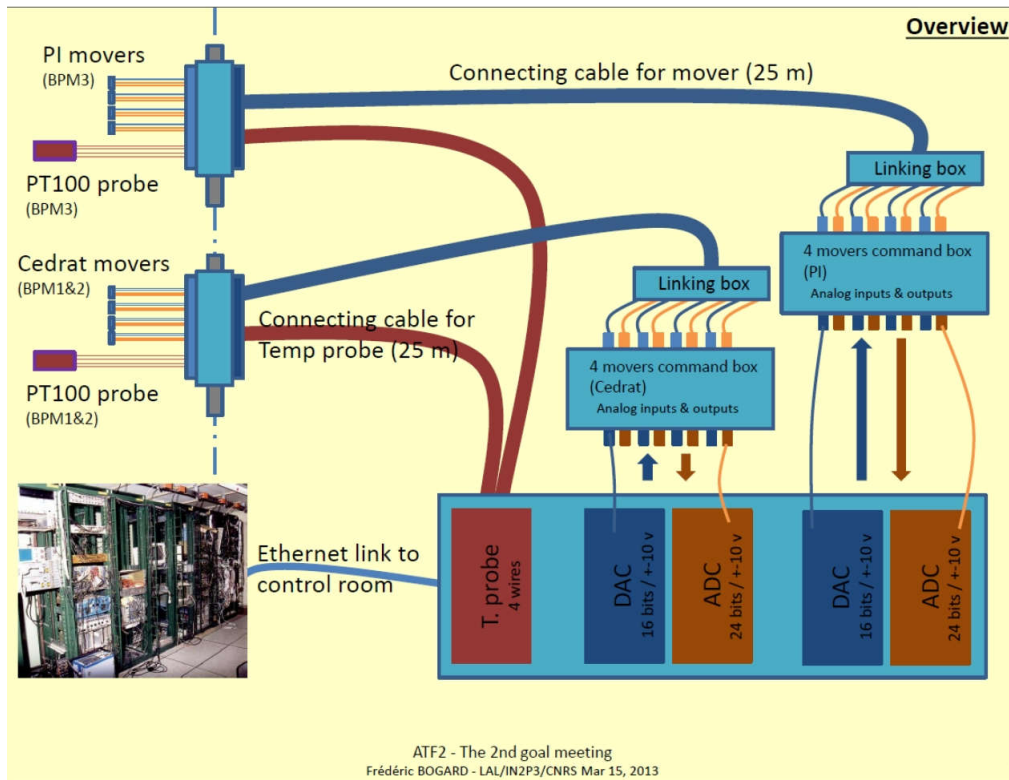

Figure B.1 – Piezo mover system connection diagram.

Mover range

PI and Cedrat have different ranges: PI 300 μm , Cedrat 250 μm . The Control voltage and displacement (min-max positions) is opposite between companies:

- PI: (min) 0 V to (max) 10 V
- CEDRAT: (max) -1 V to (min) 7 V

It is important to note that:

- The voltage-displacement relation is inverse for CEDRAT movers.
- When the system is OFF (0 V), PI mover are at its minimum, however CEDRAT are not.

Mover Control

Figure B.2 shows an schematic of the control system per mover. The voltage value is set via an EPICS Process Variable (PV), and it is send to a DAC, the analog voltage set the control box to move the piezo-electric. The displacement is measure by a set of strain-gauges. The FB loop is closed at the Control box. A read-out voltage is taken by the ADC and publish as another PV.

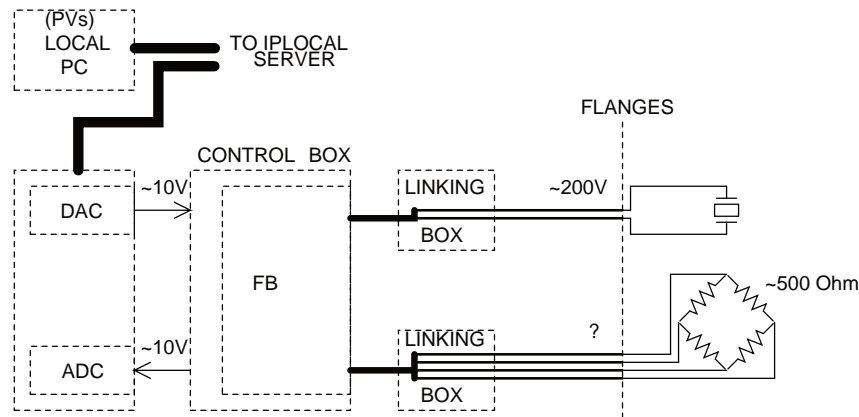

Figure B.2 – Control system per mover.

Feedback and NO Feedback

There are two operation possibilities per mover: Feedback (fb) and No Feedback (no fb). It means 8 feedback loops. On each case the control module sets a voltage value on the mover and read the strain gauge to create a closed loop. However, their implementations are different on each company.

B.1.3 The PLC

Two NI9263 are used to set analogue voltage into the mover control electronics. Two NI9239 are used to read analogue voltage from the strain gauge readback. One NI9219 is used to read temperature. These modules are connected to the chassis NI9188 which is connected by network to a working station with Labview installed. The block chassis+NI modules is called **PLC**.

National instruments Chassis: NI9188

- Mac Address: 0080.2f14.b777
- DHCP
- IP address (ATF) 31.1.1.39
- IP address (KEK): None
- Host name: ipmv-plc.ip-local
- Net Mask: 255.255.255.0
- connected to ip-local during installation

Chassis NI9188 can connect up to 8 modules, not all are used:

- PI
 - Module 5: NI9263 Digital to analogue converter
 - Module 6: NI9239 Analogue to digital converter
- Cedrat
 - Module 2: NI9263 Digital to analogue converter
 - Module 3: NI9239 Analogue to digital converter
- Temperature
 - Module 8: NI9219 Temperature probes
 - Cedrat: Channel 0
 - PI: Channel 2
- The other slots are not used

B.1.4 The PC

It is used to control from close locations the BPM positioning system. It sets the digital values to put in the PLC and reads the digital values from the PLC channels corresponding to strain gauges.

Characteristics

LAL Computer (Laptop) Processor Inter Core i7 vPro

Mac Address: d067.e550.620e

Network Parameters

DHCP

IP address(ATF): (31.1.1.38) ipmover-pc.ip-local

Net Mask: 255.255.255.0

Connected to ip-local server

Used Software

Windows 7 Francais

National Instrument - Labview 2011

National Instruments - Measurement & Automation Explorer (NI MAX) 5.4

Evince 2.32.0

CALab (Labview + EPICS) [69]

Folder Content Description

Path to applications and info

Bureau/Actionneurs Piezo/Applis

All applications were done in Labview. Filenames give an indication of its purpose, here are some keywords used in filenames:

- **oscilloscope**: uses de ADC to read signals
- **generateur**: function generator, uses de DACs to produce signals
- **Actionneurs positionnement BPMs**: activate the system displacement
- **Ethernet**: connected by wired network,
- **USB**: corresponds to previous version connected by USB.
- **Verticaux groupe**: all 3 vertical mover movers are activated by one only setting.
- **mouvements identiques**: first version of BPM displacement system (PI and CEDRAT) integrated.
- **Jauges**: stores the strain gauges info in excel format.
- **temp**: stores the strain gauges and temperature info in excel format.
- **epics**: control from epics system, Labview works as interface.

- **Actionneurs multicycles**: several cycles over the defined voltage range are performed
- **Cedrat, PI**: identifies the group of movers to use.
- **Vertical, lateral fixe**: it means that one direction of movement is set (fixed) to a voltage value while the other direction varies in cycles.

PVs

Epics PVs (Process Variables). Write: sets a value on the DAC. Read: reads from ADC.

Channels IP:BPM-AB:Mover0 and IP:BPM-C:MoverB are for lateral movement.

IP:BPM-AB:Mover0:Read

IP:BPM-AB:Mover0:Write

IP:BPM-AB:Mover1:Read

IP:BPM-AB:Mover1:Write

IP:BPM-AB:Mover2:Read

IP:BPM-AB:Mover2:Write

IP:BPM-AB:Mover3:Read

IP:BPM-AB:Mover3:Write

IP:BPM-C:MoverB:Read

IP:BPM-C:MoverB:Write

IP:BPM-C:MoverC:Read

IP:BPM-C:MoverC:Write

IP:BPM-C:MoverD:Read

IP:BPM-C:MoverD:Write

IP:BPM-C:MoverE:Read

IP:BPM-C:MoverE:Write

IP:BPM-AB:Temp

IP:BPM-C:Temp

B.2 The BPMs

B.2.1 Coordinate system

Each BPM has its own coordinates with respect to a reference system centered electrically as in Fig. B.3.

The coordinates of the beam and the BPM angle rotations are:

- Beam Position: $x_A, y_A, z_A, x_B, y_B, z_B, x_C, y_C, z_C$
- BPM Angles respect to ref. system: $\theta_{Ap}, \theta_{Ar}, \theta_{Ay}, \theta_{Bp}, \theta_{Br}, \theta_{By}, \theta_{Cp}, \theta_{Cr}, \theta_{Cy}$

All systems relate to a common mechanical reference system with no rotations, just translations in Fig. B.4. For simplification, one of the BPMs could be chosen to coincide with

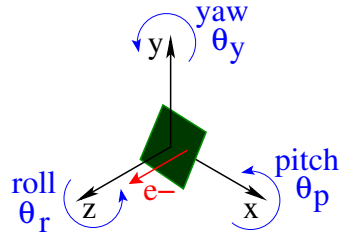

Figure B.3 – BPM coordinate system centered electrically. Beam in red, BPMs in green.

the common reference.

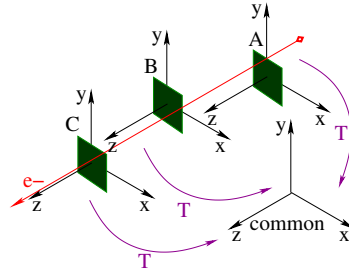

Figure B.4 – Reference system for the 3 BPMs.

The set of movers to control BPM position is shown in Fig. B.5. This is expressed in Eq. (B.1) where during the installation all initial values (with 0-index) are set. A mover combination can change the transverse positions and the pitch angle per block.

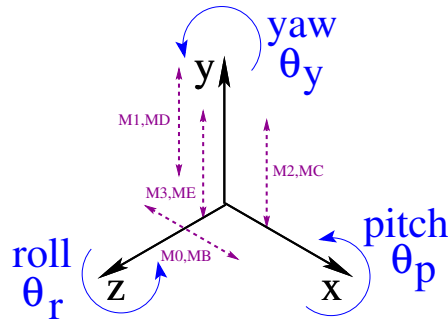

Figure B.5 – Set of movers: M_{01234} in Block IPAB and M_{BCDE} in Block IPC.

$$\begin{aligned}
 x &= x_0 + f_x(M_{0,B}) \\
 y &= y_0 + f_y(M_{123,CDE}) \\
 z &= z_0 \\
 \theta_p &= \theta_{p0} + f_p(M_{123,CDE}) \\
 \theta_r &= \theta_{r0} \\
 \theta_y &= \theta_{y0}
 \end{aligned} \tag{B.1}$$

Figure B.6 shows the location of the movers along the longitudinal direction. This information is used to calculate the alignment correction limits of the system.

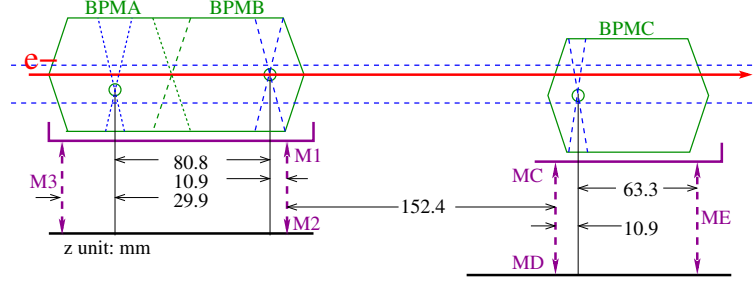

Figure B.6 – Longitudinal position of the movers.

B.2.2 Alignment adjustment

Normalizing the movers range to -1 to 1 units, as in Eq. (B.2), it is possible to calculate the effect of movers displacement on the cavity position shown in Table B.1.

$$M_{0123} = \frac{3 - V_{0123}[\text{V}]}{4} \quad M_{BCDE} = \frac{V_{BCDE}[\text{V}] - 5}{5} \quad (\text{B.2})$$

Block IPAB movers are able to correct a maximum of ± 1 mrad or $\pm 125 \mu\text{m}$, while Block IPC is able to correct ± 2 mrad or $\pm 150 \mu\text{m}$. Correction of IPA and IPB position is not independent, therefore, special effort is put into minimize the offset in the block IPAB during installation.

By making $y = 0$ and $y_0 = 0$, in Table B.1, it is also possible to find the ratio of of movers settings that keeps the vertical position and changes the angle per BPM. This gives the possibility to scan sensitivity to pitch angle.

	Adjustment		
	IPB	IPA	IPC
$x[\mu\text{m}]$	$x_{0B} + 125M_0$	$x_{0A} + 125M_0$	$x_{0C} + 150M_B$
$y[\mu\text{m}]$	$y_{0B} + 11.2M_{1,2} + 113.8M_3$	$y_{0A} + 94.8M_{1,2} + 30.2M_3$	$y_{0C} + 128.0M_{CD} + 22.0M_E$
$z[\text{mm}]$	z_{0B}	z_{0A}	z_{0C}
$\theta_p[\text{mrad}]$	$\theta_{p0B} + 1.03(M_3 - M_{1,2})$	$\theta_{p0A} + 1.03(M_3 - M_{1,2})$	$\theta_{p0C} + 2.02(M_{DC} - M_E)$
$\theta_r[\text{mrad}]$	θ_{r0B}	θ_{r0A}	θ_{r0C}
$\theta_y[\text{mrad}]$	θ_{y0B}	θ_{y0A}	θ_{y0C}

Table B.1 – Movers setting to adjust position and pitch angle. $M_{0123,BCDE} \in [-1, 1]$

B.3 Alignment

B.3.1 Vacuum chamber

The goal is the alignment of the vacuum chamber with respect to external references by less than $200 \mu\text{m}$. Below this range, the piezo-electric movers in each cavity block are used to align the cavity with respect to the beam.

The beam positioning system should not interfere with the IPBSM measurements. Therefore, mechanical dimensions and weight should be restricted to those supported by the vertical optical table. This will allow to have a common reference point between the two structures.

B.3.2 Effect of alignment on dynamic range

Dynamic range is reduced by misalignment because of the constant I' and Q' signals from position and angle. This should be minimize aiming to use the maximum dynamic range possible in calibrations and to be near the center of the piezo-movers dynamic range, where linearity is better.

However, IPA and IPB are located in a common movers system and therefore BPM position and angle can not be corrected independently. Both BPMs centers can be aligned with the beam by making an angle, but, due the cavity sensitivity to angle of $3.2 \mu\text{m}/\text{mrad}$, the Q' will substract the dynamic range available for position scans. This adds to the Q' static signal per BPM and therefore it could become critical.

The initial BPM installation [61] had alignment issues attributed to loose tolerances between the inner cavity surface and the external reference points [70]. During 2014, new cavities were fabricated and installed in the ATF2 line. This set of BPMs has been in use since November 2014.

At present there are two methods to check the alignment:

- Position scans with $I' = 0$. This is fairly simple because it only tries to find the center of the BPM without considering the Q' signal. The issue is that beam angle through the IPBPMs changes and these leads to different alignment results. A typical change of 0.1 mrad in the beam trajectory by a QD0 displacement of $100 \mu\text{m}$ could change the alignment results by $25 \mu\text{m}$ from IPA to IPC. An incertitude of $\pm 10 \mu\text{m}$ in $I' = 0$ has been estimated by analysing different samples in the waveforms. Table B.2 shows the horizontal and vertical alignment of the new BPMs taken in separated shifts.
- Position and angle scans to make $I' = 0$ and $Q' = 0$. First, make $I' = 0$ and then use the BPM movers and/or QF7 movers combination to make $Q' = 0$. This method is valid for Q' entirely from angle. At the moment it has not been tested with the new BPMs. Table B.3 shows the vertical position results for the previous BPMs. However, the result was corrected after the improvement of the acquisition system. Some initial results in 2013 where resolution limited due to the use of 8 bits oscilloscopes to acquire the waveforms, imposing a resolution limit of the Q' measurement of 1 mrad , which is too large.

Plane	IPA	IPB	IPC	Comment
X [μm]	-5	+18	-41	QD0 mover(X)=-70 μm , 10BX1BY optics
Y [μm]	-18	+24	-102	QD0 mover(Y)=160 μm , Low beta optics

Table B.2 – Alignment measurement using $I' = 0$

Vertical	IPA	IPB	IPC
Y [μm]	-7	+79	-
θ_p [mrad]	0.024	1.0	-

Table B.3 – Alignment measurement using $I' = 0$ and $Q' = 0$ for previous BPMs.

B.3.3 Effect of cavity alignment on calibration

After the installation the cavities are fixed in the piezo-movers system. Figure B.7a shows an static angle β between the movers direction and the BPM axis, while the beam makes an angle α with respect to the movers.

When doing a position scan to get the BPM calibration the BPM is displaced by L_m , however, the displacement seen by the BPM is L_{BPM} . Equation (B.3) shows the effect of the angles in the measured distance and Fig. B.7b shows the combinations of α and β affecting the calibration by less than 10^{-3} and 10^{-4} .

Considering α , the beam divergence is 0.35 mrad in the nominal optics which is very small and do not affect calibration. The angle change by QF7 has been simulated to have an excursion of 3 mrad at IPB per 1 mm of vertical displacement of QF7, this also remains in below the 10^{-4} effect.

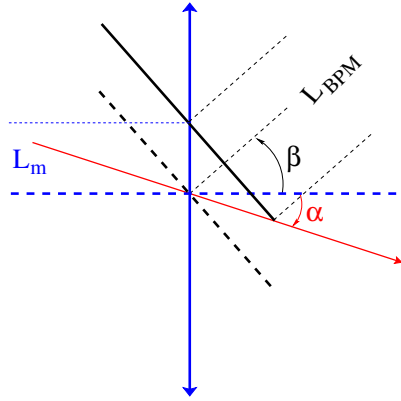

(a) Displacement from the center. Movers displace by L_m . Cavity sees L_{BPM}

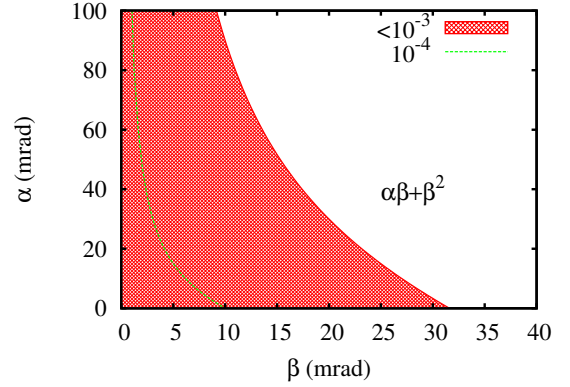

(b) α and β should be inside the dashed area to keep the calibration value within 10^{-3} precision.

$$\begin{aligned} L_{BPM} &= L_m (\cos \beta + \sin \beta \tan(\alpha + \beta)) \\ &\approx L_m (1 + \alpha\beta + \beta^2) \end{aligned} \quad (\text{B.3})$$

If the movers are used to induce an additional angle γ to the BPMs as in Fig. B.8, then the net effect is an addition of $\beta + \gamma$ shown in Eq. (B.4).

$$L_{BPM} \approx L_m [1 + \alpha(\beta + \gamma) + (\beta + \gamma)^2] \quad (\text{B.4})$$

The total correction possible for the BPMs is $|\gamma| \leq 1$ mrad. It is also a very small angle. The more restrictive angle is $|\beta| < 5$ mrad.

B.3.4 Mechanical BPM alignment

The estimation of mechanical positions resolution is shown in Table B.4.

Axis (Symbol)	Mechanical Precision (μm)
Vertical (Δy)	1
Horizontal (Δx)	5
Longitudinal (Δz)	5

Table B.4 – Position mechanical precision

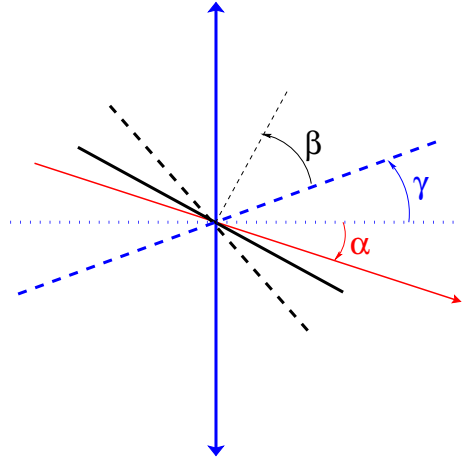

Figure B.8 – γ angle rotation over the BPM. The only effect on distance measured is to add γ to β .

Bibliography

- [1] Chris Adolphsen, Maura Barone, Barry Barish, Karsten Buesser, Philip Burrows, John Carwardine, Jeffrey Clark, H el ene Mainaud Durand, Gerry Dugan, Eckhard Elsen, Atsushi Enomoto, Brian Foster, Shigeki Fukuda, Wei Gai, Martin Gastal, Rongli Geng, Camille Ginsburg, Susanna Guiducci, Mike Harrison, Hitoshi Hayano, Keith Kershaw, Kiyoshi Kubo, Victor Kuchler, Benno List, Wanming Liu, Shinichiro Michizono, Christopher Nantista, John Osborne, Mark Palmer, James McEwan Paterson, Thomas Peterson, Nan Phinney, Paolo Pierini, Marc Ross, David Rubin, Andrei Seryi, John Sheppard, Nikolay Solyak, Steinar Stapnes, Toshiaki Tauchi, Nobu Toge, Nicholas Walker, Akira Yamamoto, and Kaoru Yokoya. The International Linear Collider Technical Design Report - Volume 3.I: Accelerator R&D in the Technical Design Phase, technical report (arXiv:1306.6353. ANL-HEP-TR-13-20. BNL-100603-2013-IR. IRFU-13-59. CERN-ATS-2013-037. Cockcroft-13-10. CLNS-13-2085. DESY-13-062. FERMILAB-TM-2554. IHEP-AC-ILC-2013-001. ILC-REPORT-2013-040. INFN-13-04-LNF. JAI-2013-001. JINR-E9-2013-35. JLAB-R-2013-01. KEK-Report-2013-1. KNU-CHEP-ILC-2013-1. LLNL-TR-635539. SLAC-R-1004. ILC-HiGrade-Report-2013-003), Comments: See also <http://www.linearcollider.org/ILC/TDR> . The full list of signatories is inside the Report, Geneva: KEK, June 2013 (see pp. [3](#), [5](#), [24](#), [25](#), [32](#), [58](#), [59](#)).
- [2] M Aicheler, P Burrows, M Draper, T Garvey, P Lebrun, K Peach, N Phinney, H Schmickler, D Schulte, and N Toge. A Multi-TeV Linear Collider Based on CLIC Technology: CLIC Conceptual Design Report, technical report (CERN-2012-007. SLAC-R-985. KEK-Report-2012-1. PSI-12-01. JAI-2012-001), Geneva: CERN, 2012 (see pp. [3](#), [5](#), [24](#), [25](#), [31](#), [40](#), [58](#), [59](#)).
- [3] Katsunobu Oide. Synchrotron-radiation limit on the focusing of electron beams, *Phys. rev. lett.*, 61:1713–1715, 15, October 1988, DOI: 10.1103/PhysRevLett.61.1713 (see pp. [3](#), [5](#), [57](#), [58](#), [61](#), [103](#)).
- [4] M. Sands. EMITTANCE GROWTH FROM RADIATION FLUCTUATIONS, *Slac pubs and reports*, 1985 (see pp. [3](#), [5](#), [29](#), [49](#), [50](#), [103](#)).
- [5] Placet, <https://savannah.cern.ch/projects/placet/> Link consulted 2013.04.17 (see pp. [3](#), [5](#), [49](#), [51](#), [60](#), [103](#)).
- [6] James Brau, Yasuhiro Okada, and Nicholas Walker. Ilc reference design report volume 1 - executive summary, technical report (arXiv:0712.1950), Comments: A version with high resolution pictures can be found at <http://www.linearcollider.org/cms/?pid=1000437> The full authorlist is inside the report, December 2007 (see p. [21](#)).
- [7] Hector Garcia Morales, Rogelio Tomas Garcia, and Yuri Kubyshin. Comparative study of Final Focus Systems for CLIC and other luminosity enhancement studies for future linear colliders, Presented 16 Jan 2015, PhD thesis, Barcelona, Polytechnic U., 2014 (see pp. [22](#), [25](#), [30–33](#), [39](#)).

- [8] The CMS Collaboration. A new boson with a mass of 125 gev observed with the cms experiment at the large hadron collider, *Science*, 338(6114):1569–1575, 2012, DOI: 10.1126/science.1230816, eprint: <http://www.sciencemag.org/content/338/6114/1569.full.pdf> (see p. 22).
- [9] The ATLAS Collaboration. A particle consistent with the higgs boson observed with the atlas detector at the large hadron collider, *Science*, 338(6114):1576–1582, 2012, DOI: 10.1126/science.1232005, eprint: <http://www.sciencemag.org/content/338/6114/1576.full.pdf> (see p. 22).
- [10] S. Kraml. SUSY status after one year of LHC, 2012, arXiv: 1206.6618 [hep-ph] (see p. 22).
- [11] R W Assmann, M Lamont, and S Myers. A Brief History of the LEP Collider, *Nucl. phys. b, proc. suppl.*, 109(CERN-SL-2002-009-OP):17–31. 15 p, April 2002 (see p. 23).
- [12] G. Feldman. Prospects for Physics at e+e- Linear Colliders, 1988, eprint: SLAC-PUB-4563 (slac) (see p. 23).
- [13] J. Seeman. The Stanford Linear Collider, 1991, SLAC-PUB-5607: SLAC-PUB-5607 (SLAC) (see p. 23).
- [14] John Ellis. The Physics Prospects for CLIC, *Balk.phys.lett.*, 17:17037, 2009, arXiv: 0811.1366 [hep-ph] (see p. 23).
- [15] E. Accomando et al. Physics at the CLIC multi-TeV linear collider, 2004, arXiv: hep-ph/0412251 [hep-ph] (see p. 23).
- [16] R.W. Assmann, F. Becker, R. Bossart, H. Burkhardt, Hans-Heinrich Braun, et al. A 3-TeV e+ e- linear collider based on CLIC technology, 2000 (see p. 23).
- [17] R. M. Barnett, C. D. Carone, D. E. Groom, T. G. Trippe, C. G. Wohl, B. Armstrong, P. S. Gee, G. S. Wagman, F. James, M. Mangano, K. Mönig, L. Montanet, J. L. Feng, H. Murayama, J. J. Hernández, A. Manohar, M. Aguilar-Benitez, C. Caso, R. L. Crawford, M. Roos, N. A. Törnqvist, K. G. Hayes, K. Hagiwara, K. Nakamura, M. Tanabashi, K. Olive, K. Honscheid, P. R. Burchat, R. E. Shrock, S. Eidelman, R. H. Schindler, A. Gurtu, K. Hikasa, G. Conforto, R. L. Workman, C. Grab, and C. Amsler. Review of particle physics, *Phys. rev. d*, 54:1–708, 1, July 1996, DOI: 10.1103/PhysRevD.54.1 (see p. 24).
- [18] High energy collider parameters, <http://pdg.lbl.gov/2010/reviews/rpp2010-rev-hep-collider-params.pdf> Link consulted 2013.02.19 (see p. 24).
- [19] K. L. Brown. A Conceptual Design of Final Focus Systems for Linear Colliders, *Slac*, 1987 (see p. 25).
- [20] *CAS-CERN Accelerator School: 4th General accelerator physics course. Julich, FR Germany*, Proceedings of CAS 91-04, 1990 (see p. 27).
- [21] K. L. Brown. Basic Optics of the SLC Final Focus System, *Slac*, 1988 (see p. 27).
- [22] Raimondi P. and Seryi A. A Novel Final Focus Design for Future Linear Colliders. *Slac*, 2000 (see pp. 27, 70).
- [23] Daniel Schulte. Study of Electromagnetic and Hadronic Background in the Interaction Region of the TESLA Collider, Presented on Apr 1997, PhD thesis, Hamburg: Hamburg U., 1997 (see pp. 28, 29).
- [24] P. Bambade, R. Erickson, Wayne A. Koska, W. Kozanecki, N. Phinney, et al. Observation of Beam-beam Deflections at the Interaction Point of the SLAC Linear Collider, *Phys.rev.lett.*, 62:2949, 1989, DOI: 10.1103/PhysRevLett.62.2949 (see pp. 28, 74).

- [25] O Napoly. The luminosity for beam distributions with error and wakefield effects in linear colliders, August 1992 (see p. 29).
- [26] Javier Barranco Garcia, Eduardo Marin Lacoma, and Rogelio Tomas Garcia. Luminosity studies in a traveling waist regime in the compact linear collider, *Phys. rev. st accel. beams*, 16:041001, 4, April 2013, DOI: 10.1103/PhysRevSTAB.16.041001 (see pp. 29, 51).
- [27] Tigner M. Chao W. Mess K. and Zimmermann F. *Handbook of accelerator physics and engineering*, World Scientific, second edition edition, 2013 (see p. 29).
- [28] Michiko G Minty and Frank Zimmermann. *Measurement and control of charged particle beams*, of *Particle acceleration and detection*, Springer, Berlin, 2003 (see p. 30).
- [29] *Balakin, V.E.* Third International Workshop on Linear Colliders (LC91), Protvino, USSR, 1991 (see p. 32).
- [30] Hector Garcia Morales and Rogelio Tomas Garcia. Final-focus systems for multi-teV linear colliders, *Phys. rev. st accel. beams*, 17:101001, 10, October 2014, DOI: 10.1103/PhysRevSTAB.17.101001 (see p. 44).
- [31] G. Xu. General conditions for self-cancellation of geometric aberrations in a lattice structure, *Phys. rev. st accel. beams*, 8:104002, 10, October 2005, DOI: 10.1103/PhysRevSTAB.8.104002 (see pp. 44, 62).
- [32] MAD-X, <http://mad.web.cern.ch/mad/> Link consulted 2015.04.22 (see p. 45).
- [33] *A Recipe for Linear Collider Final Focus System Design*. Proceedings of PAC2003, 2003 (see p. 45).
- [34] R. Tomás. Nonlinear optimization of beam lines, *Phys. rev. st accel. beams*, 9:081001, 8, August 2006, DOI: 10.1103/PhysRevSTAB.9.081001 (see pp. 46, 58).
- [35] R Tomás. MAPCLASS: a code to optimize high order aberrations, technical report (AB-Note-2006-017. CERN-AB-Note-2006-017), CERN, January 2007 (see pp. 46, 58).
- [36] D Martinez, A Rosam, R Tomas, and R De Maria. MAPCLASS2: a code to aid the optimisation of lattice design, *Cern note*, November 2012 (see pp. 46, 58).
- [37] Mapclass2, <https://github.com/pylhc/MapClass2> Link consulted 2014.01.13 (see pp. 46, 58).
- [38] M. Sands. *The Physics of Electron Storage Rings: An Introduction*, *Slac pubs and reports*, 1970 (see p. 49).
- [39] Maxima, <http://maxima.sourceforge.net/> Link consulted 2013.02.19 (see p. 59).
- [40] Mathematica, <http://www.wolframalpha.com/> Link consulted 2013.02.19 (see p. 59).
- [41] R. Tomás. Overview of the compact linear collider, *Phys. rev. st accel. beams*, 13:014801, 1, January 2010, DOI: 10.1103/PhysRevSTAB.13.014801 (see p. 59).
- [42] Daniel Schulte. Beam-Beam Simulations with GUINEA-PIG, March 1999 (see p. 63).
- [43] K. Kubo et al. Extremely low vertical emittance beam in accelerator test facility at KEK, *Phys.rev.lett.*, 88:194801, 2002, DOI: 10.1103/PhysRevLett.88.194801 (see p. 67).

- [44] Y. Honda, K. Kubo, S. Anderson, S. Araki, K. Bane, A. Brachmann, J. Frisch, M. Fukuda, K. Hasegawa, H. Hayano, L. Hendrickson, Y. Higashi, T. Higo, K. Hirano, T. Hirose, K. Iida, T. Imai, Y. Inoue, P. Karataev, M. Kuriki, R. Kuroda, S. Kuroda, X. Luo, D. McCormick, M. Matsuda, T. Muto, K. Nakajima, Takashi Naito, J. Nelson, M. Nomura, A. Ohashi, T. Omori, T. Okugi, M. Ross, H. Sakai, I. Sakai, N. Sasao, S. Smith, Toshikazu Suzuki, M. Takano, T. Taniguchi, N. Terunuma, J. Turner, N. Toge, J. Urakawa, V. Vogel, M. Woodley, A. Wolski, I. Yamazaki, Yoshio Yamazaki, G. Yocky, A. Young, and F. Zimmermann. Achievement of ultralow emittance beam in the accelerator test facility damping ring, *Phys. rev. lett.*, 92:054802, 5, February 2004, DOI: 10.1103/PhysRevLett.92.054802 (see p. 67).
- [45] M. Berndt, V. Bressler, K. Brown, F. Bulos, K. Bunnell, et al. Final focus test beam: Project design report, 1991 (see p. 67).
- [46] S. Araki et al. Proposal of the Next Incarnation of Accelerator Test Facility at KEK for the International Linear Collider, 2005 (see p. 67).
- [47] ATF2 Collaboration. ATF2 Proposal, *SLAC*, SLAC-R-771, 2005 (see pp. 67, 68, 73).
- [48] B.I. Grishanov et al. ATF2 Proposal. Vol. 2, technical report, ATF2 Group, 2006, pages 1–43 (see p. 67).
- [49] Maria del Carmen Alabau Pons. Optics studies and performance optimization for a future linear collider: final focus system for the e-e- option (ilc) and damping ring extraction line (atf), PHD Thesis, Departamento de Fisica Atomica, Molecular I Nuclear, Universitat de Valencia, 2010 (see p. 68).
- [50] Yves Renier. Implementation and validation of the linear collider final focus prototype : ATF2 at KEK (Japan), PhD thesis, Universite Paris XI Orsay, 2010 (see pp. 68, 70, 72).
- [51] M D Woodley and P E Emma. Measurement and Correction of Cross-Plane Coupling in Transport Lines, (physics/0008194. SLAC-PUB-8581):3 p, August 2000 (see p. 70).
- [52] T. Okugi, S. Araki, P. Bambade, K. Kubo, S. Kurado, M. Masuzawa, E. Marin, T. Naito, T. Tauchi, N. Terunuma, R. Tomas, J. Urakawa, G. White, and M. Woodley. Linear and second order optics corrections for the kek accelerator test facility final focus beam line, *Phys. rev. st accel. beams*, 17:023501, 2, February 2014, DOI: 10.1103/PhysRevSTAB.17.023501 (see p. 71).
- [53] PATECKI, M. and others. Ultra-low beta study, CLIC Workshop 2015, January 2015 (see p. 71).
- [54] Tsumoru Shintake. Proposal of a nanometer beam size monitor for e+e- linear colliders, *Nuclear Instruments and Methods in Physics Research Section A: Accelerators, Spectrometers, Detectors and Associated Equipment*, 311(3):453–464, 1992, DOI: [http://dx.doi.org/10.1016/0168-9002\(92\)90641-G](http://dx.doi.org/10.1016/0168-9002(92)90641-G) (see p. 72).
- [55] T. Shintake et al. Experiments of nanometer spot size monitor at FFTB using laser interferometry, Contributed paper at 1995 Particle Accelerator Conference and International Conference on High-Energy Accelerators, May 1 - 5, 1995, Dallas, Texas, U.S.A. (see p. 73).
- [56] J. Yan. Precise measurement of nanometer scale electron beam size using laser interference by shintake monitor, Ph.D. Thesis, Komamiya Laboratory, Graduate School of Science, The University of Tokyo, 2014 (see p. 73).
- [57] H. Hayano. Wire scanners for small emittance beam measurement in ATF, 2000, arXiv: physics/0008084 (see p. 73).
- [58] PATECKI, M. and others. ATF2 December run ground motion study, CLIC Workshop 2015, January 2015 (see p. 73).

- [59] *TOWARDS INTERNATIONAL LINEAR COLLIDER: EXPERIMENTS AT ATF2*, Proceedings of IPAC2014, 2014 (see p. 74).
- [60] K. Kubo. ATF2 progress report, CLIC Workshop 2015, January 2015 (see p. 74).
- [61] *IN VACUUM HIGH ACCURACY MECHANICAL POSITIONING SYSTEM OF NANO RESOLUTION BEAM POSITION MONITOR AT THE INTERACTION POINT OF ATF2*, Proceedings of IPAC2013, 2013 (see pp. 77, 116).
- [62] T. Nakamura. Development of beam-position monitors with high position resolution, Master Thesis, Department of Physics, Graduate School of Science, The University of Tokyo, 2008 (see pp. 78, 80, 81).
- [63] Y. I. Kim, R. Ainsworth, A. Aryshev, S. T. Boogert, G. Boorman, J. Frisch, A. Heo, Y. Honda, W. H. Hwang, J. Y. Huang, E-S. Kim, S. H. Kim, A. Lyapin, T. Naito, J. May, D. McCormick, R. E. Mellor, S. Molloy, J. Nelson, S. J. Park, Y. J. Park, M. Ross, S. Shin, C. Swinson, T. Smith, N. Terunuma, T. Tauchi, J. Urakawa, and G. R. White. Cavity beam position monitor system for the accelerator test facility 2, *Phys. rev. st accel. beams*, 15:042801, 4, April 2012, DOI: 10.1103/PhysRevSTAB.15.042801 (see p. 78).
- [64] T. Shintake and and. Development Of Nanometer Resolution Rf-Bpms:341–345, 1998 (see p. 80).
- [65] N. Blaskovic. Position to angle sensitivity, ATF IP BPM Meeting, January 2015 (see p. 85).
- [66] Yoichi Inoue, Hitoshi Hayano, Yosuke Honda, Toshikazu Takatomi, Toshiaki Tauchi, Junji Urakawa, Sachio Komamiya, Tomoya Nakamura, Tomoyuki Sanuki, Eun-San Kim, Seung-Hwan Shin, and Vladimir Vogel. Development of a high-resolution cavity-beam position monitor, *Phys. rev. st accel. beams*, 11:062801, 6, June 2008, DOI: 10.1103/PhysRevSTAB.11.062801 (see p. 96).
- [67] T. Nakamura. Development of beam-position monitors with high position resolution, Master’s thesis, Tokyo, Japan: Departement of Physics, Graduate School of Science, The University of Tokyo, 2008 (see p. 97).
- [68] P. Burrows and FONT. Bunch-bunch feedback and IP beam stabilization, 18th ATF2 Project Meeting, February 2015 (see p. 99).
- [69] Ca lab (labview + epics), http://www-csr.bessy.de/control/SoftDist/CA_Lab. Link consulted 2014.11.06. (see p. 112).
- [70] *The High Position Resolution Cavity BPMs Developments and Measurements for ILC Final Focus System*, Proceedings of IPAC2014, 2014 (see p. 116).