

CERN - PRE 87 - 083

9

ISTITUTO NAZIONALE DI FISICA NUCLEARE

-22 NOV. 1987

Sezione di Trieste

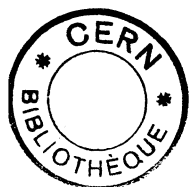

INFN/AE-87/4

22 Giugno 1987

J. Kewisch, H. Kreiser, T. Niinikoski, Y. Onel, A. Penzo and and R. Rossmannith:

**CONSIDERATIONS ON INSTALLING A STRONG SOLENOID IN A LOW ENERGY STORAGE RING**

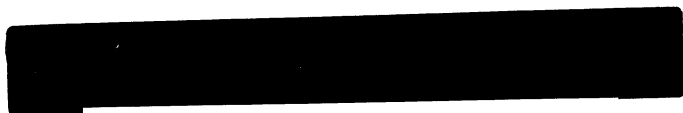

CERN LIBRARIES, GENEVA



CM-P00062922

PLEASE  
MAKE A  
PHOTOCOPY  
or check out as  
NORMAL  
LOAN

Servizio Documentazione  
dei Laboratori Nazionali di Frascati

CONSIDERATIONS ON INSTALLING A STRONG SOLENOID IN A  
LOW ENERGY STORAGE RING

J. Kewisch<sup>1)</sup>, H. Kreiser<sup>2)</sup>, T. Niinikoski<sup>3)</sup>, Y. Onel<sup>4)</sup>,  
A. Penzo<sup>3)</sup>\* and R. Rossmann<sup>1)</sup>

ABSTRACT

Recently a method was proposed to polarize the stored antiprotons in LEAR. Particles with different spins are separated by a device called spin-splitter consisting of skew-quadrupoles and a strong solenoid.

In this paper it is shown in principle that the spin splitter with its strong solenoid field can be integrated into a low energy storage ring such as LEAR, without long changes in the optics.

- 
- 1) CEBAF, Newport News, Virginia
  - 2) University of Hamburg, Hamburg
  - 3) CERN, Geneva
  - 4) University of Geneva and Austin, Texas
- \* On leave from INFN-Trieste

## 1. INTRODUCTION

A method to polarize the stored antiproton beam in LEAR has been recently proposed [1]. In this method spins aiming into different directions are separated by the Stern-Gerlach effect. Two strong skew quadrupoles induce kicks on the particle trajectory. These kicks add over many revolutions until particles with opposite spin directions are separated by macroscopic distances.

In order to achieve a net separation a solenoid in between the skew quadrupoles has to be installed. This unit is called spin splitter (Fig. 1).

The solenoid has to provide a strong field (its integrated field strength is about 30 percent of the integrated field strength of all bending magnets). In the following it is shown that it is in principle possible to incorporate such a device in the LEAR ring, using an existing solenoid.

This is a first approach to the problem. The present solution still has to be modified in order to meet the detailed requirements of the existing LEAR straight sections [2].

## 2. THE MODIFIED OPTICS

The original LEAR optics is shown in Fig. 2. The beta functions are identical for each quadrant and do not exceed 22m. The calculations are performed by the programs COMFORT [2] and PETROS [3]. The results are in good agreement with MAD calculations performed at CERN [4].

The solenoid of the spin-splitter usually couples horizontal beam motion into vertical motion and viceversa. The skew quadrupoles have to be designed in such a way that the coupling is compensated. The compensated spin-splitter disturbs the symmetry of the ring. A series of calculations were performed for a superconductive solenoid (2.5 Tesla) with a length of 1.6 m in order to demonstrate the feasibility of such a compensation scheme.

In the following it is assumed that the strength of the solenoid can be changed within 30 percent. As a consequence it was found that two skew quadrupoles on each side of the solenoid have to be installed (Fig. 3).

Further on a solution could only be found when the two LEAR quadrupoles pairs next to the spin-splitter have different K-values compared to rest of the ring (Fig. 4).

Table I shows two possible solutions for a spin-splitter. The calculations for decoupling have been done using the program MINUIT [5]. For two given geometries (D1 and D2) the R-value of the solenoid is varied. The R-value is defined in the following way

$$R = eB / pc = 0.3 B / p \text{ (Tesla / GeV/c)}$$

Note that according to Table I the maximum beta-functions depend on the R-value of the solenoid. Fig. 5 and 6 illustrate this behaviour for a total length of  $L = 4.2$  m. For  $R = 2.0$  (Fig. 5) the optics is not so different compared to the original optics shown in Fig. 1. For  $R = 1.91$  the beta-functions become very high (Fig. 6) and cannot be taken into account for a realistic scheme.

### 3. SUMMARY

It is shown in principle that a spin splitter consisting of a strong solenoid quadrupoles can be installed in LEAR without disturbing too much the original optics.

The straight section foreseen for the spin splitter in LEAR will be in the near future equipped with a low beta insertion. Therefore the next optical calculations will concentrate on the question if part of the low beta section can be used for the spin splitter, e.g. by rotating two of the low beta quadrupoles by 45 degree. Such a solution has the advantage that existing power supplies can be used.

### 4. ACKNOWLEDGEMENTS

The authors wish to thank S. Baird, P. Lefevre and D Møhl from the LEAR group for advice and discussions.

L (m)	D <sub>1</sub> (m)	D <sub>2</sub> (m)	R [1/m]	$\frac{QFN}{K}$ (1/m <sup>2</sup> )	$\frac{QDN}{K}$ (1/m <sup>2</sup> )	$\frac{QFN1}{K}$ (1/m <sup>2</sup> )	$\frac{QDN1}{K}$ (1/m <sup>2</sup> )	$\frac{Sk1}{K}$ (1/m <sup>2</sup> )	$\frac{Sk2}{K}$ (1/m <sup>2</sup> )	max $\beta_x$ (m)	max $\beta_z$ (m)
4.2	0.2	0.1	1.91	-1.15	1.32	-1.97	1.92	-9.17	-0.62	23.8	180
	0.2	0.1	2.0	-1.36	1.45	-1.93	1.84	-2.87	-1.21	12.6	36
	0.2	0.1	2.6	-1.52	1.46	-1.9	1.88	+0.25	+7.31	18.2	413.4
4.6	0.3	0.2	1.8	-1.41	1.58	-2.02	1.88	-6.5	-0.28	16.9	119.5
			2.0	-1.3	1.38	-1.96	2.03	-1.32	-2.11	12.1	78.6
			2.5	-1.53	1.63	-1.99	1.82	0.57	9.06	15.4	268.8
LEAR	-	-	-	-1.4	1.27	-1.4	+1.27	-	-	10.7	21.8
											Standard

TABLE I - Optical parameters of LEAR with and without the spin-splitter.

## REFERENCES

- [1] Y. Onel, A. Penzo, R. Rossmannith, Proc. "Ettore Majorana" Internat. School of Physics with Low-Energy Antiprotons, Erice, Sept. 1986, in preparation.
- [2] S. Baird - Some numbers concerning a gas-jet in LEAR, LEAR note PS/LEA/Note 87-06, March 1987.
- [3] M. Woodley, J. Jaeger, M. J. Lee and A. S. King, COMFORT Stanford Linear Accelerator Center, 1983.
- [4] J. Kewisch, Berechnungen der linearen gekoppelten Optik und der Strahlparameter in Elektronenbeschleunigern unter Beruecksichtigung von Magnetfehlern, Diplomarbeit, University of Hamburg, 1978.
- [5] D. Møhl and R. Giannini, private communication.
- [6] F. James, M. Roos MINUIT, a system for function minimization and analysis of the parameter errors and correlation. CERN/DD internal report 75/20.

## FIGURE CAPTIONS

- Fig. 1: The spin-splitter scheme.
- Fig. 2: The original LEAR optics.
- Fig. 3: The spin-splitter consisting of two pairs of skew quadrupoles and a solenoid.
- Fig. 4: The implementation of the spin-splitter in LEAR.
- Fig. 5: LEAR optics with the spin-splitter in one of the straight sections.
- Fig. 6: Similar to Fig. 4. The strength of the solenoid is reduced.

L (m)	D <sub>1</sub> (m)	D <sub>2</sub> (m)	R [1/m]	$\frac{QFN}{K}$ (1/m <sup>2</sup> )	$\frac{QDN}{K}$ (1/m <sup>2</sup> )	$\frac{QFN1}{K}$ (1/m <sup>2</sup> )	$\frac{QDN1}{K}$ (1/m <sup>2</sup> )	$\frac{Sk1}{K}$ (1/m <sup>2</sup> )	$\frac{Sk2}{K}$ (1/m <sup>2</sup> )	max $\beta_x$ (m)	max $\beta_z$ (m)
4.2	0.2	0.1	1.91	-1.15	1.32	-1.97	1.92	-9.17	-0.62	23.8	180
	0.2	0.1	2.0	-1.36	1.45	-1.93	1.84	-2.87	-1.21	12.6	36
	0.2	0.1	2.6	-1.52	1.46	-1.9	1.88	+0.25	+7.31	18.2	413.4
4.6	0.3	0.2	1.8	-1.41	1.58	-2.02	1.88	-6.5	-0.28	16.9	119.5
			2.0	-1.3	1.38	-1.96	2.03	-1.32	-2.11	12.1	78.6
			2.5	-1.53	1.63	-1.99	1.82	0.57	9.06	15.4	268.8
LEAR	-	-	-	-1.4	1.27	-1.4	+1.27	-	-	10.7	21.8
											Standard

TABLE I - Optical parameters of LEAR with and without the spin-splitter.

## REFERENCES

- [1] Y. Onel, A. Penzo, R. Rossmannith, Proc. "Ettore Majorana" Internat. School of Physics with Low-Energy Antiprotons, Erice, Sept. 1986, in preparation.
- [2] S. Baird - Some numbers concerning a gas-jet in LEAR, LEAR note PS/LEA/Note 87-06, March 1987.
- [3] M. Woodley, J. Jaeger, M. J. Lee and A. S. King, COMFORT Stanford Linear Accelerator Center, 1983.
- [4] J. Kewisch, Berechnungen der linearen gekoppelten Optik und der Strahlparameter in Elektronenbeschleunigern unter Beruecksichtigung von Magnetfehlern, Diplomarbeit, University of Hamburg, 1978.
- [5] D. Mühl and R. Giannini, private communication.
- [6] F. James, M. Roos MINUIT, a system for function minimization and analysis of the parameter errors and correlation. CERN/DD internal report 75/20.

## FIGURE CAPTIONS

- Fig. 1: The spin-splitter scheme.
- Fig. 2: The original LEAR optics.
- Fig. 3: The spin-splitter consisting of two pairs of skew quadrupoles and a solenoid.
- Fig. 4: The implementation of the spin-splitter in LEAR.
- Fig. 5: LEAR optics with the spin-splitter in one of the straight sections.
- Fig. 6: Similar to Fig. 4. The strength of the solenoid is reduced.



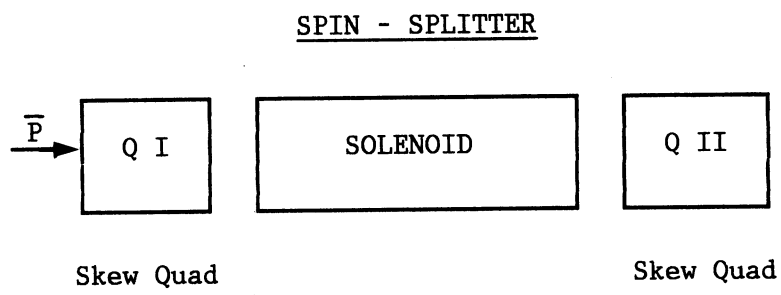

Fig. 1

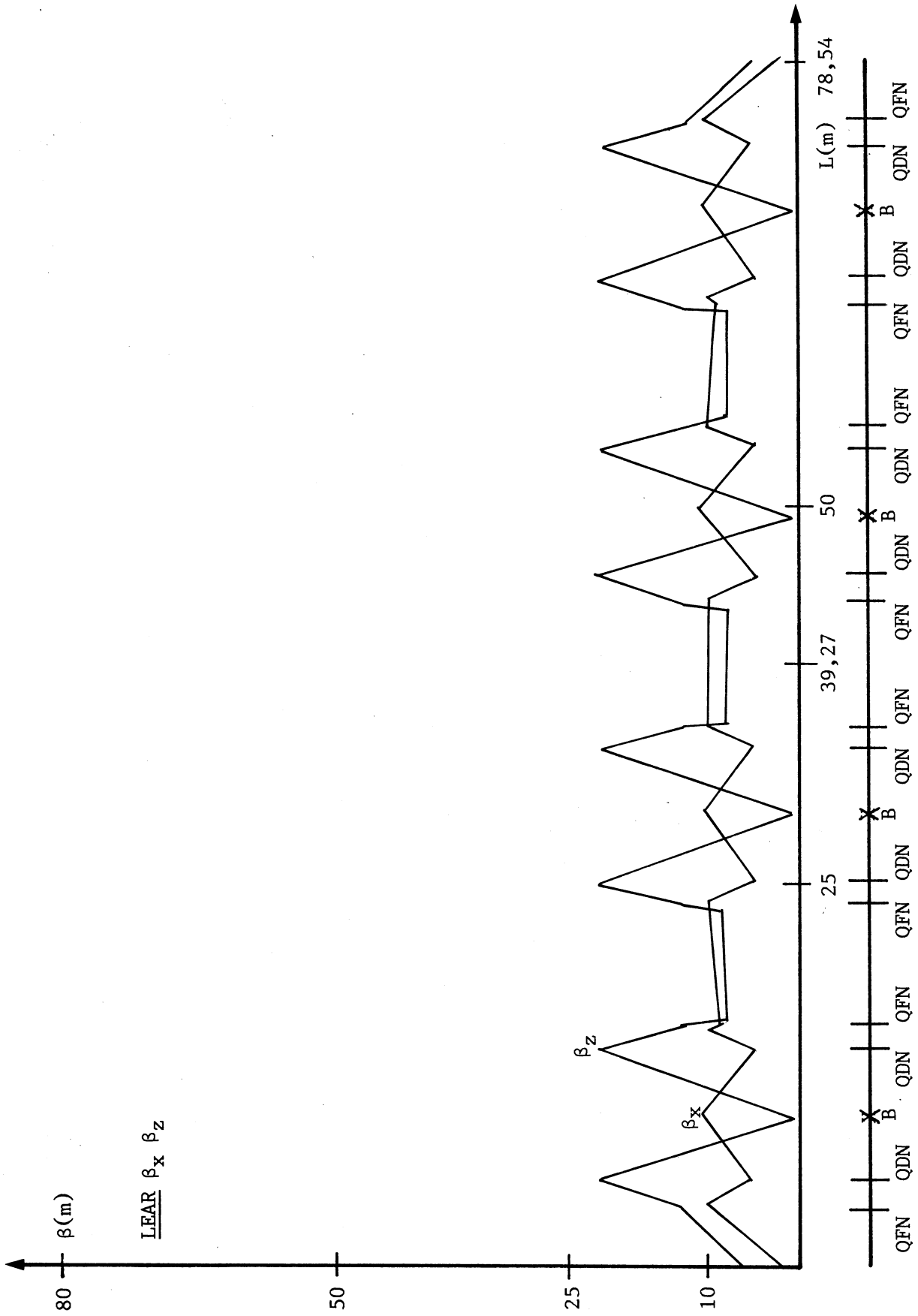

Fig. 2

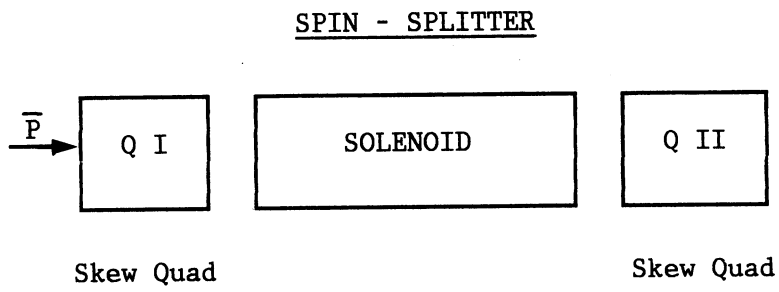

Fig. 1

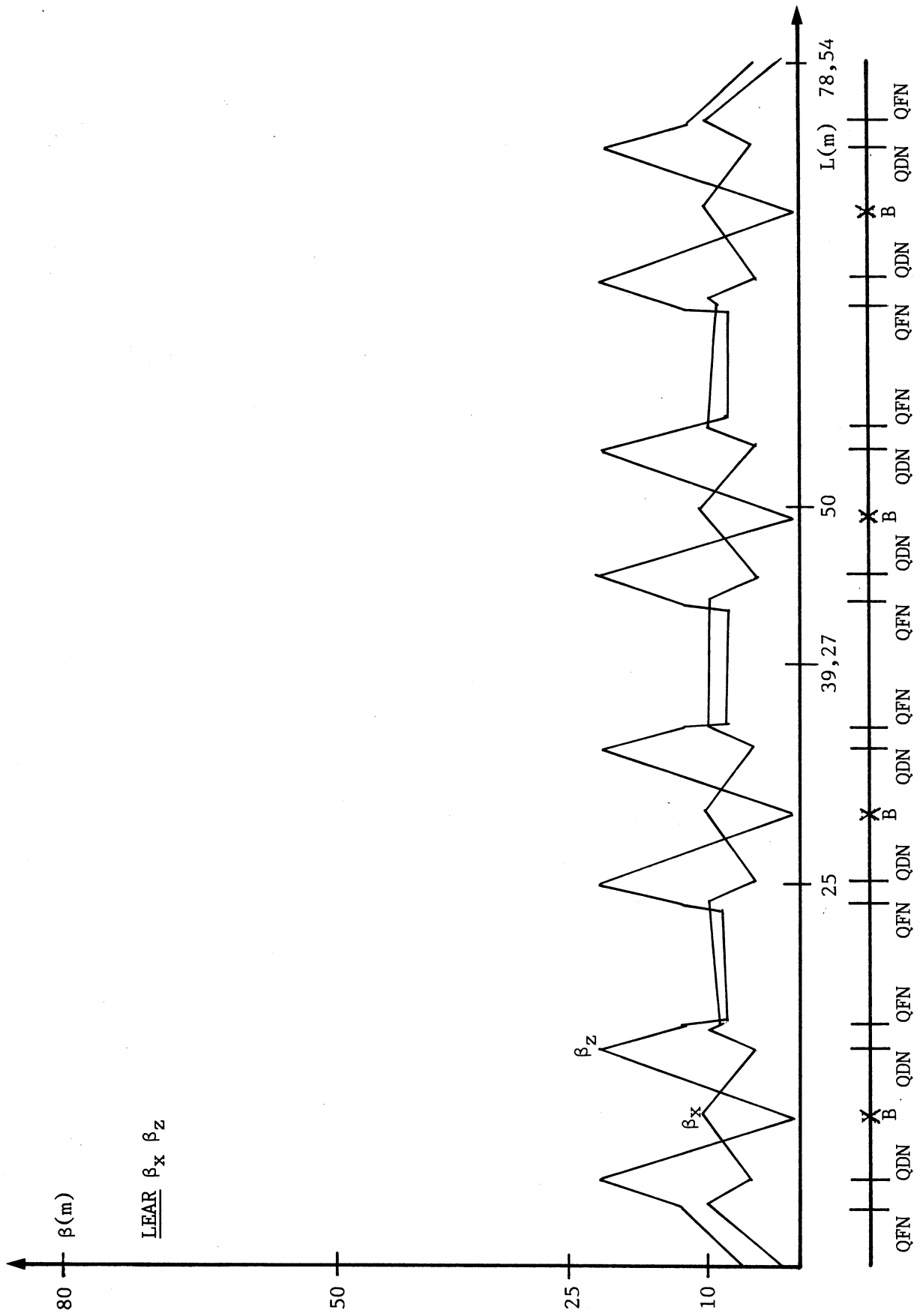

Fig. 2

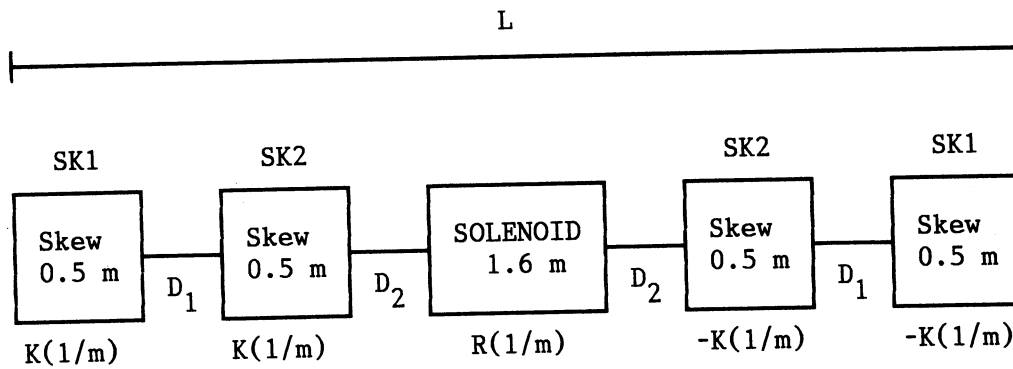
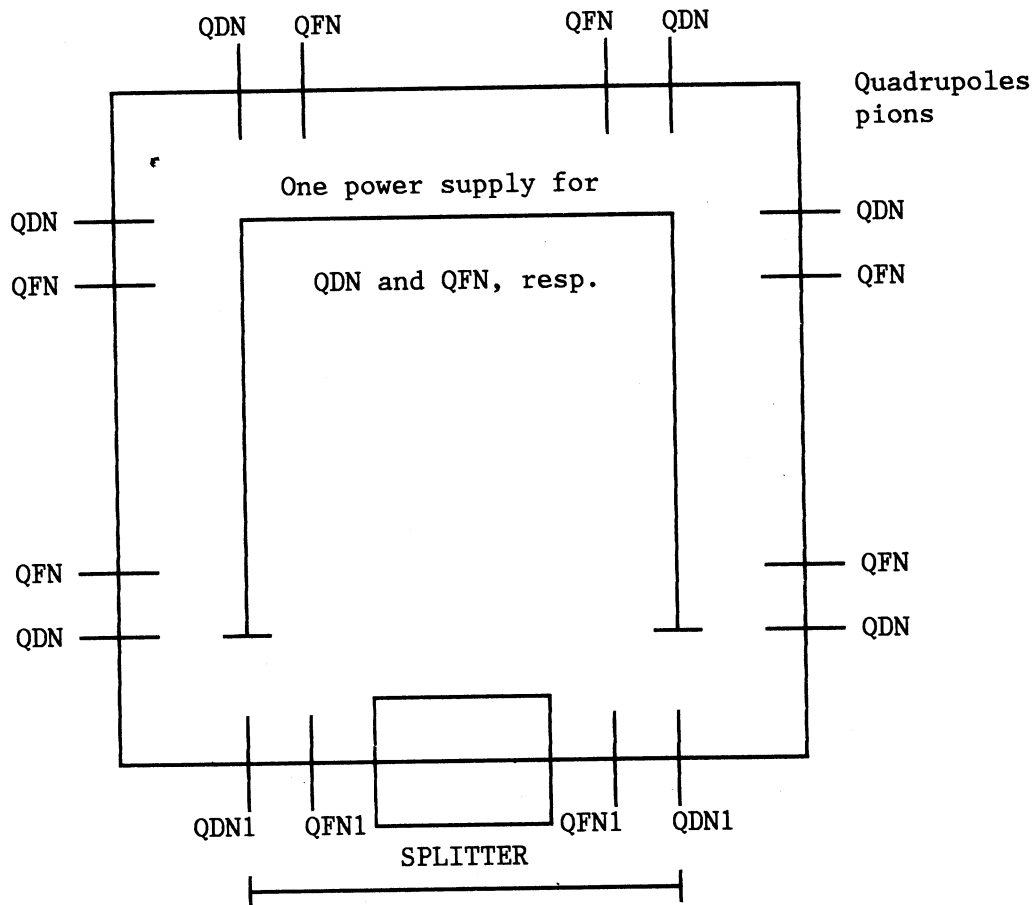

Fig. 3



QFN and QDN in this region have different power supplies

Fig. 4



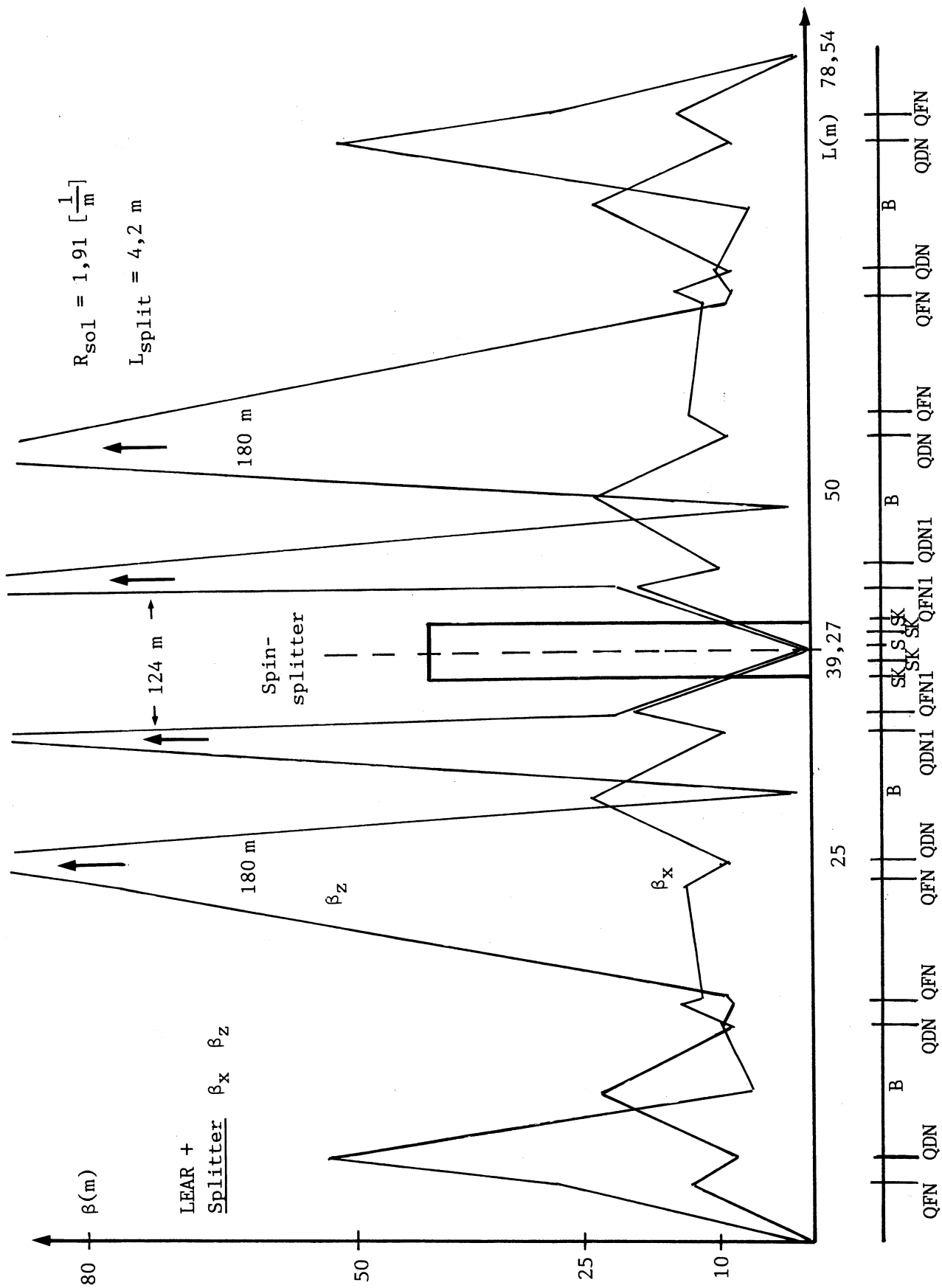

Fig. 6

