

A HIGH-POWER TARGET SYSTEM FOR RADIOISOTOPE PRODUCTION

J.J. Burgerjon, Z. Gelbart, G.O. Hendry*,
J.C. Lofvendahl, L. McIlwraith, G.A. Pinto**,
TRIUMF, 4004 Wesbrook Mall, Vancouver, B.C. Canada V6T 2A3

CERN LIBRARIES, GENEVA



CM-P00068224

EE
BIBLIOTHEQUE
Abstract
12 JAN. 1987

To utilize the powerful external beams, available from H⁻ cyclotrons, a high-power, target system was designed by The Cyclotron Corp. of Berkeley, CA and further developed at TRIUMF. The system consists of two target stations served by beam lines from a 42 MeV cyclotron (CP-42) and a pneumatic "rabbit" system that transfers the targets to the radio chemistry hot cells. The targets can accept a 28 MeV proton beam of 200 μ A, while the target surface temperature is kept below 150°C. The system has been in operation for three years for the production of radioisotopes for the AECL Radio Chemical Co. This paper describes the system with the Mark II version of the target stations. The whole system has been in operation for over three years. The Mark II target stations have been in operation for over one year and are particularly trouble free and easy to operate and service.

Introduction

The irradiation of target materials with powerful particle beams requires a target that is cooled well enough to prevent the material from sublimating into the surrounding vacuum. For certain materials this dictates a maximum target temperature of 160°C. Such a target was developed in 1980.

Targets are preferably located in a special target cave, but can also be located in the cyclotron vault. Both target cave and cyclotron vault are high radiation areas and the irradiated target itself is a very strong radiation source. For these reasons target placement in and removal from the target stations and transport to the radio-chemistry hotcell has to be completely by remote control.

A target is transported between target stations and hot cell via a "rabbit", which is blown through a plastic tube. Target transfer from the rabbit into the beam line and back takes place in a target station. The system with two target stations was installed and commissioned in 1982. Based on experience over the first few years, the target stations were replaced by improved versions, respectively in June and October 1985, resulting in dramatically improved reliability.

High Power Target

A target is shown in Fig. 1. The target face is made of silver to provide good thermal conductivity combined with relatively low activation and compatibility with chemical processing of the target material. This face is soft soldered onto a copper base which is bolted onto the aluminum target body with the water passages sealed with Buna-N O-rings. Only the hub, which engages with the manipulator, is made of stainless steel to provide the necessary hardness.

Cooling of the target was enhanced by adding fins to the back of the target face, which is in contact with the cooling water. A computer program was used to determine the optimum dimensions of these fins.¹ The design was confirmed by instrumenting a copper test target with four thermo-couples located in the core of

*With Computer Technology and Imaging Inc., 950 Gilman St., Berkeley, CA 94710, USA - which acquired all proprietary rights from The Cyclotron Corporation.

**Formerly with The Cyclotron Corporation, Berkeley, CA.

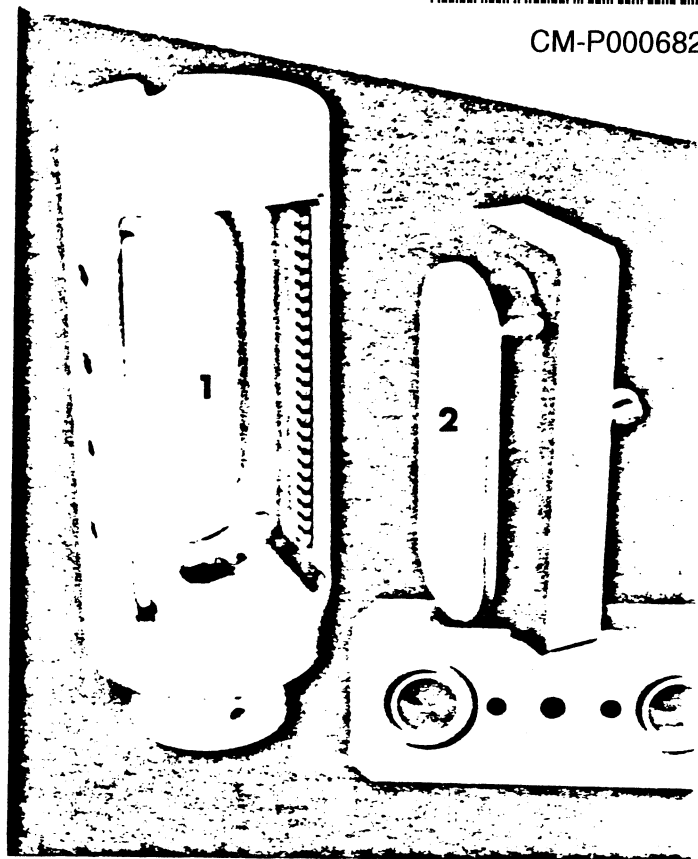

Fig. 1 Rabbit (1) and target (2)

the beam spot and bombarding it with a 28 MeV proton beam.

Target Stations

Fig. 2 shows the major parts of a target station: the target chamber, which is connected to the beam line via a gate valve; the tube terminal, located vertically at the end of the transfer tube; and the target manipulator. The operation is best followed referring to Fig. 3, showing horizontal sections of a target station at various stages of target transfer.

Fig. 3A shows the target during irradiation by the proton beam, defined by vertical and horizontal collimating posts upstream of and inside the target chamber. To retrieve the target at the end of an irradiation the beam is switched off and an empty rabbit, as shown in Fig. 1, is sent from the hot cell (Fig. 3B). Subsequently the beam line gate valve is closed, the diffusion pump connected to the target chamber is valved off and the target chamber is vented. At the same time the target cooling water is shut off and the cooling lines are purged with compressed air. The manipulator retracts the target from the target port to clear the way for the terminal (Fig. 3C). The terminal swings down from its vertical to a horizontal position exposing the empty rabbit (Fig. 3D). The manipulator places the target in the rabbit (Fig. 3E). The manipulator retracts again leaving the target behind (Fig. 3F). The terminal swings back into its vertical position (Fig. 3G). Finally the rabbit with the target is sent back to the hot cell (Fig. 3H).

HIGH POWER TARGET. REMOTE CHANGE SEQUENCE.

- 1. BEAM.
- 2. TARGET.
- 3. TERMINAL.
- 4. MANIPULATOR.
- 5. RABBIT.

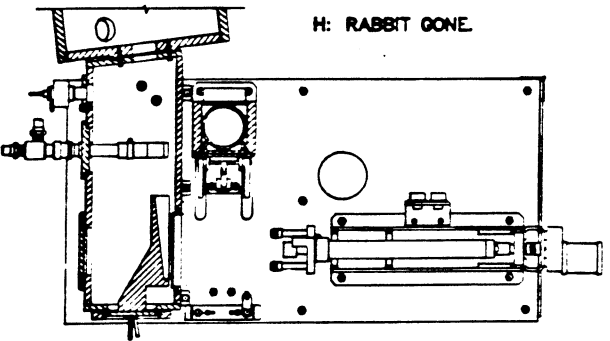
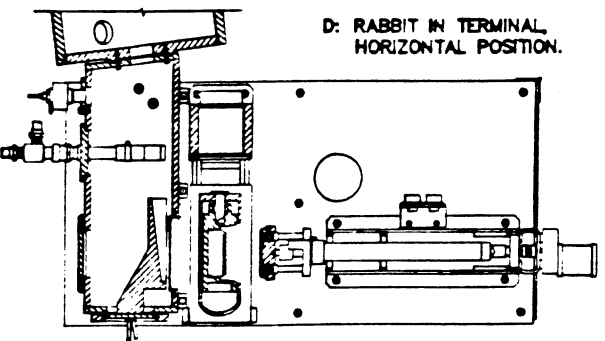
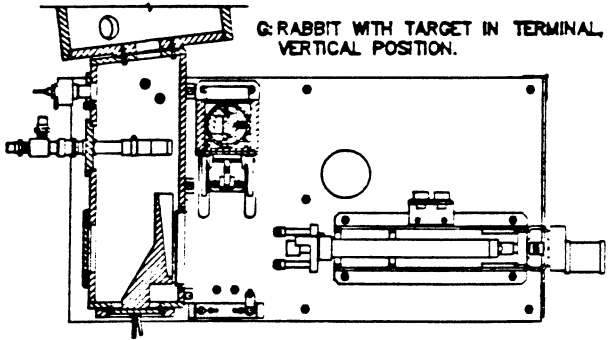
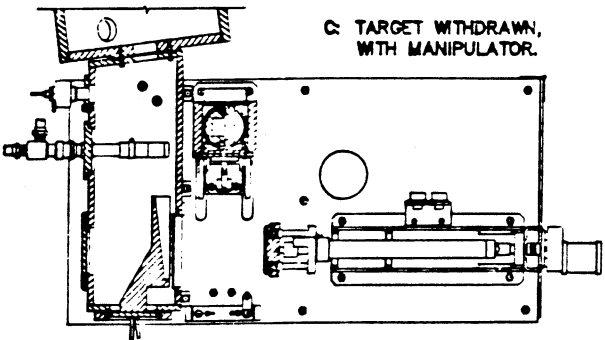
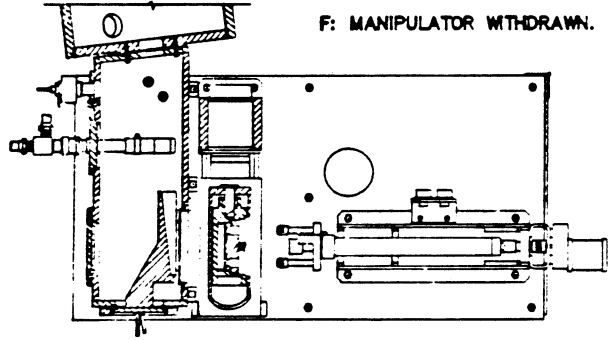
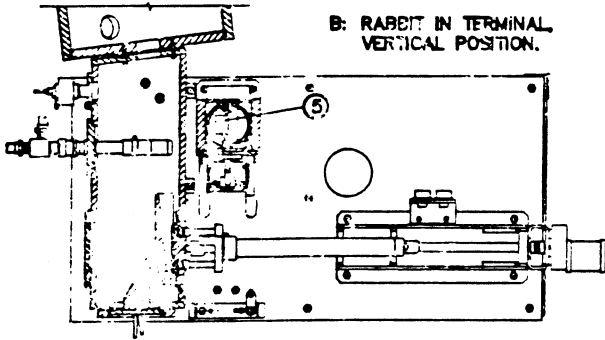
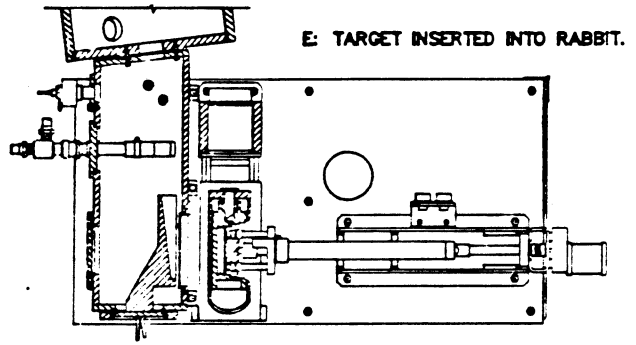
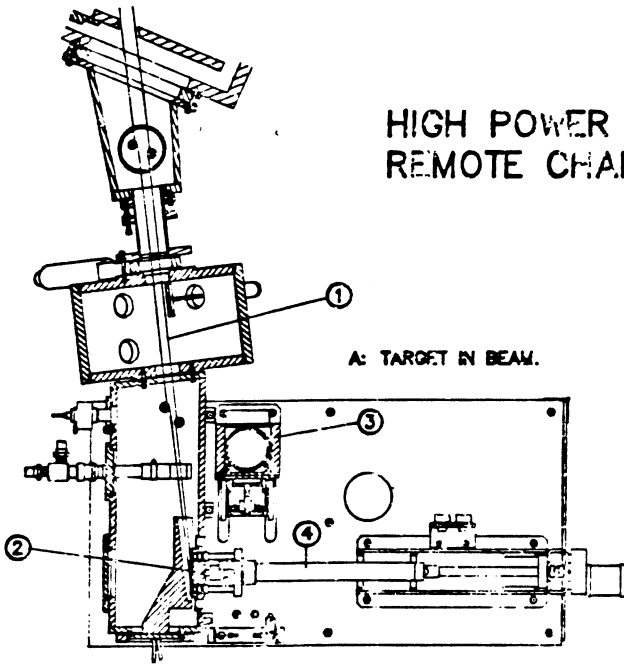

Fig. 3

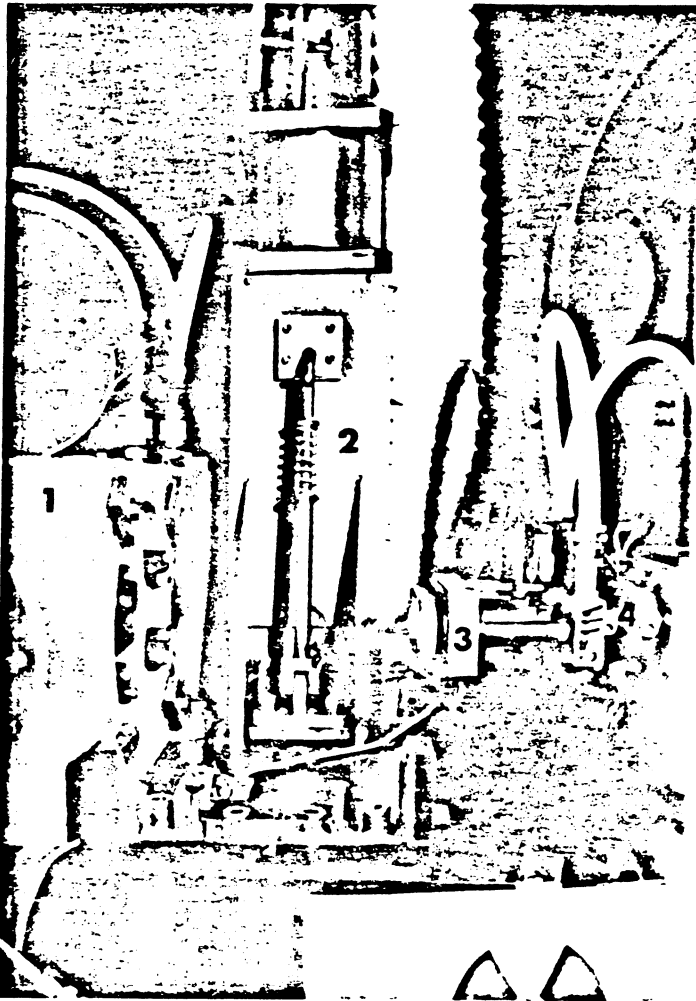

Fig. 2 Target station central area.

1. Target chamber
2. Rabbit terminal
3. Target
4. Manipulator

To place a target in the beam this sequence is essentially reversed. A new target is placed in a rabbit in the hot cell and sent off. About 15 minutes is required to pump down the target chamber before the beam line gate valve can be opened and the beam may be switched on. After the target has been placed in the beam line, the empty rabbit is returned to the hot cell so as not to leave it exposed to the strong neutron field during target irradiation.

The target chamber is inclined at an angle of 7 degrees with respect to the beam line to achieve the proper angle of incidence of the beam on the flat target.¹ Immediately upstream of the target is a diagnostics box with a wire scanner that can be used at the full 200 μ A beam current and a scintillator that can be used when the beam is less than 50 nA.²

The front end of the manipulator and the target are insulated in order to monitor the beam current. To minimize the effect of secondary emission an electron catcher envelopes the target, except where the beam enters. The catcher is also insulated and can electrically be connected to the target. It was found, however, that connecting the catcher via an empirically determined bias voltage gives the best results.

The electron catcher can be removed for target alignment. By inserting a target coated with a scintillator the beam distribution can be observed at low beam currents via a television camera looking through the viewing window opposite the target.

The material used for the electron catcher, target chamber and, where possible, any other components in the vicinity of the target is aluminum, which substantially reduces neutron induced activation of the target station as compared to stainless steel. The target stand-offs and the manipulator front end are made of 'Vespel' to provide electrical insulation for the target with good radiation hardness. The flexible target cooling tubes are made of poly-ethylene. The seals between target and target chamber port and the cooling connectors on the manipulator are standard Buna-N O-rings.

Target Transport System

Fig. 4 shows the two receive stations, as seen by the hot cell operator. Each is connected to a target station via standard 7.5 cm diameter air chute tubing. Like the terminals in the target stations the receive stations are vertical. Directly above them, brakes are installed that grab the rabbit on arrival, then release it so it will land softly.

In the target station terminal the rabbit must always land with the open side facing the manipulator. The rabbit therefore lands on a specially shaped hard steel index pin to achieve the necessary rotation.

The blower assembly that drives the rabbit contains two standard industrial vacuum cleaner blowers in series. These provide enough pressure difference to lift the rabbit, which weighs about 1.4 kg when it contains a target. The flow direction can be reversed by switching the tubes around with respect to the blower assembly. A line selector assembly allows the same blower assembly to be used for the two target systems.

Using an air driven rabbit system to transport targets to and from a hot cell carries with it the possibility of contamination. The air system, therefore, is arranged such that the air is always returned to the area where it came from and the exhausts from the target systems are ducted out to the ventilation system filters.

Control System

Target transfer, placement, station pumpdown, etc. are all handled by a programmable controller for minimal operator input. There are three user selectable modes of operation: 'complete cycle', 'partial cycle' and 'manual control'. In all three modes software and hardware interlocks are active, ensuring that each operation is successful and does not take more than the allowable time to execute. During target irradiations the target chamber pressure, target and collimator water flows etc., are continuously monitored and any failure would cause the beam to be turned off and the beam line valve to close.

The programmable controller was used effectively to correct minor unanticipated operating flaws. For example, due to friction from the target cooling coupling o-rings the target would not readily release from the manipulator and stay in the rabbit. A mere spurt of purging air at the time of release solved this problem. This required only the addition of a few program lines, while conventional hardwiring would have meant several more switches and relays.

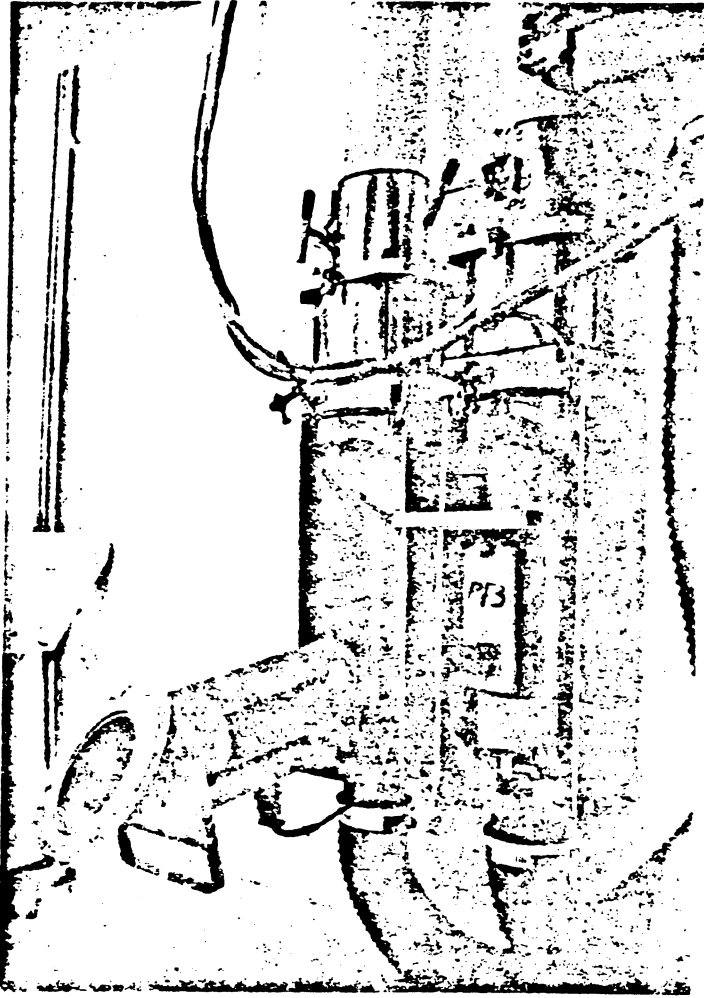

Fig. 4 Receive stations in hot cell, seen through the leadglass window. The station at the left is opened with a master-slave manipulator for insertion of a rabbit.

Operating Experience

Fig. 5 gives an overall view of a target station. The stations as described have completed 436 full transfer cycles with the first and 237 with the second target station since their installation in 1985. During this time we have had only one failure with each target station, when the manipulator dropped the target. Since the target drops onto a table outside the target chamber it is not too difficult to salvage. Target systems are an essential link in the radio-isotope production process. Therefore it was important to continue their development to achieve a low failure rate.

The target O-rings are replaced every time a target is prepared for a new irradiation, but, they have proven still useable after several tens of mAh at 23 MeV. The manipulator cooling coupling O-rings, and the polyethylene target cooling tubes, are replaced once every 4 weeks. The cooling tubes will be replaced by flexible stainless steel tubes make them radiation hard.

References

- ¹G. Pinto, M. Straatmann, D. Schlyer, J. Currin, G. Hendry, Target Systems for Radioisotope Production, Proc. 7th Conf. on the Appl. of Accelerator in Res. and Ind. Denton Texas, 1982.
- ²P. Bloemhard, Z. Gelbart, High Current Beam Profile Monitor (Wire Scanner), Proc. 11th Int. Conf. on Cyclotrons and their Appl., Tokyo, Japan, 1986



Fig. 5

Target station - overall view.